

AD-780 714

INDUCTANCES OF FOLDED FOIL CONFIGURATIONS

J. Darryl Holder

Army Missile Command
Redstone Arsenal, Alabama

April 1974

DISTRIBUTED BY:

NTIS

National Technical Information Service
U. S. DEPARTMENT OF COMMERCE
5285 Port Royal Road, Springfield Va. 22151

UNCLASSIFIED

SECURITY CLASSIFICATION OF THIS PAGE (When Data Entered)

REPORT DOCUMENTATION PAGE		READ INSTRUCTIONS BEFORE COMPLETING FORM
1. REPORT NUMBER RG-74-8	2. GOVT ACCESSION NO.	3. RECIPIENT'S CATALOG NUMBER AD-780 714
4. TITLE (and Subtitle) INDUCTANCES OF FOLDED FOIL CONFIGURATIONS		5. TYPE OF REPORT & PERIOD COVERED Technical Report
		6. PERFORMING ORG. REPORT NUMBER
7. AUTHOR(s) J. Darryl Holder		8. CONTRACT OR GRANT NUMBER(s)
9. PERFORMING ORGANIZATION NAME AND ADDRESS US Army Missile Research, Development and Engineering Laboratory US Army Missile Command Redstone Arsenal, Alabama 35809		10. PROGRAM ELEMENT, PROJECT, TASK AREA & WORK UNIT NUMBERS
11. CONTROLLING OFFICE NAME AND ADDRESS		12. REPORT DATE April 1974
		13. NUMBER OF PAGES 15
14. MONITORING AGENCY NAME & ADDRESS (if different from Controlling Office)		15. SECURITY CLASS. (of this report) Unclassified
		16. DECLASSIFICATION/DOWNGRADING SCHEDULE
16. DISTRIBUTION STATEMENT (of this Report) Approved for public release; distribution unlimited.		
17. DISTRIBUTION STATEMENT (of the abstract entered in Block 20, if different from Report)		
18. SUPPLEMENTARY NOTES None		
19. KEY WORDS (Continue on reverse side if necessary and identify by block number) Exploding foil Low-inductance circuit Noninductive resistors Produced by NATIONAL TECHNICAL INFORMATION SERVICE U.S. Department of Commerce Springfield, VA 22161		
20. ABSTRACT (Continue on reverse side if necessary and identify by block number) The purpose of this work was to explore the methods for construction of low-inductance exploding foil packages. The conducting media was 0.001-inch aluminum foil and was folded accordion-pleat fashion with dielectric sheets interleaved to produce a compact switch package that may be placed between the conductors of a parallel-plate transmission line. The results of this study show good fit of measured foil package inductances with the expected behavior and imply that it is indeed possible to use foils of long length in low-inductance circuits.		

DD FORM 1 JAN 73 1471

EDITION OF 1 NOV 65 IS OBSOLETE

UNCLASSIFIED

SECURITY CLASSIFICATION OF THIS PAGE (When Data Entered)

CONTENTS

	Page
1. Purpose	3
2. Theory	3
3. Experimental	4
4. Results	7
5. Conclusions	11
Appendix RAW DATA FROM INDUCTANCE MEASUREMENTS	13

ACKNOWLEDGMENT

Appreciation is expressed to Mr. Robert Sobieske of BDM, Inc., for his patience in fabricating the foil models and taking the many measurements involved.

1. Purpose

The purpose of this work was to explore the methods for construction of low-inductance exploding foil packages. The conducting media was 0.001-inch aluminum foil and was folded accordian-pleat fashion with dielectric sheets interleaved to produce a compact switch package that may be placed between the conductors of a parallel-plate transmission line.

2. Theory

In order to produce a shunt-opening switch capable of stopping the flow of high currents, one must observe certain limits of volts-per-meter stress in order to prevent the formation of "restrike" - the formation of a metallic arc. For any operating voltage this dictates a minimum length of exploding conductor to be used. The inductance of a foil varies in direct proportion to its length. If it is to be operated in a circuit where stray inductance is to be kept to a minimum, some method to reduce the switch-foil inductance must be used.

Noninductive resistors have been constructed for many years by folding the required length of resistance wire back upon itself so that the magnetic flux of the first half is opposed by the flux of the last half. If magnetic coupling is good (i.e., the wires are very close together) the field cancellation is very good and the only inductance present is that associated with the bend and the terminations. Another inductance-reduction technique is to make the conductors not wires, but wide straps or plates since inductance is inversely proportional to width.

Since thin metallic foils have been used extensively as exploding conductors as well as wires, it is possible to build switch packages of low inductance by folding of wide foils, as other experimenters^{1,2} have done. For lowest inductance, one should logically use a foil as wide as the system's transmission-line plates and to place the package between the plates for lowest connection inductance. A cross-section of a folded foil connected to the end of a parallel-plate line is shown in Figure 1. As shown, a power source connected to the input terminals

¹ DiMarco and Burkhardt, "Characteristics of a Magnetic Energy Storage System Using Exploding Foils," Journal of Applied Physics, Vol. 41, No. 9, August 1970, p 3894.

² Early and Martin, "Method of Producing a Fast Current Rise from Energy Storage Capacitors," The Review of Scientific Instruments, Vol. 36, No. 7, July 1965, p 1000.

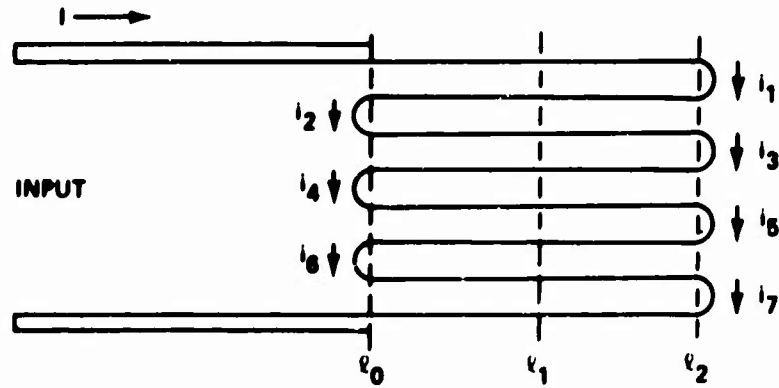

Figure 1. Cross-section of folded foil at end of parallel-plate line.

will cause a current I to flow. Since the same current flows in every part of the circuit, the uncancelled currents (i.e., in the folds) differ by one (4 to 3 in the figure) and the ratio approaches 1 to 1 as the folds become numerous. In this manner the magnetic fields at locations l_0 and l_2 approach being equal and thereby the inductance should approach that of a short between top and bottom plates at location l_1 .

3. Experimental

The tests were run using a low-inductance test fixture, a series of different configurations of folded foils, and a Bounton digital L/C meter, model 700A. The test fixture was made up (Figure 2) as a means of flaring the 0.75-inch spaced binding posts on the L/C meter front panel into a plate transmission line configuration of width to match the aluminum foil stock. A series of eleven folded foil configurations were made and measured. They were designated L1 through L11 and the physical configurations are shown in Figures 3 through 8. Electrical contact with test fixture extends 0.5 inch to left of X-X.

The last foil configuration (L11) was a many-lap package of a total of 45 creases similar in cross-section to Figures 4 and 5. This package was also full 18 inches in width with an active foil length of 206.75 inches. The foil length of the three-crease packages was 17.75 inches and the five-crease was 26.75 inches. All foil configurations were separate packages securely bound for stability during handling. For each test approximately 15 trials were made to reduce experimental error and the L/C meter was periodically checked with a low-inductance standard.

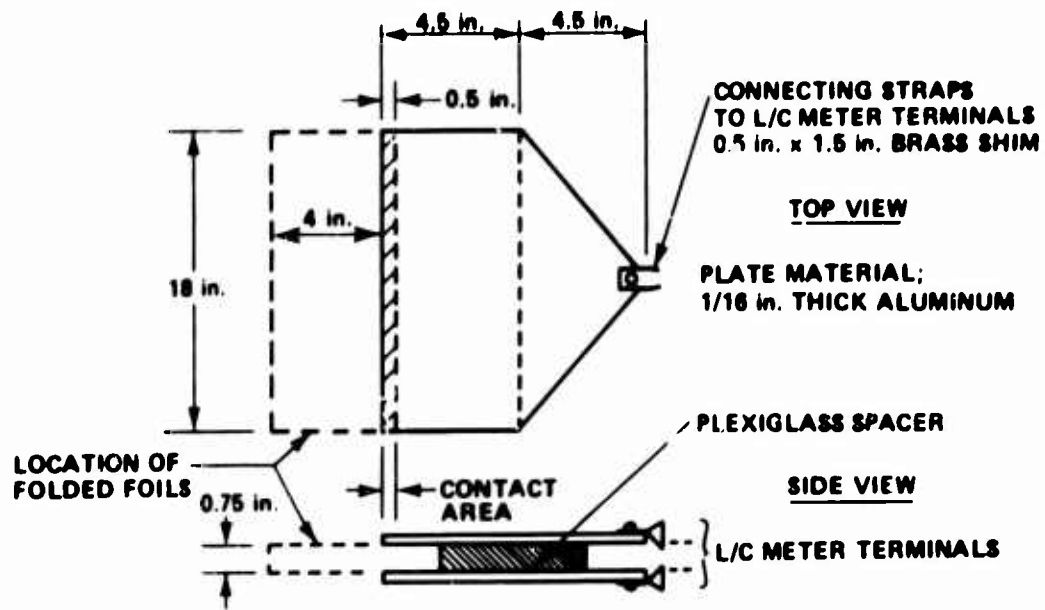

Figure 2. Low inductance test fixture.

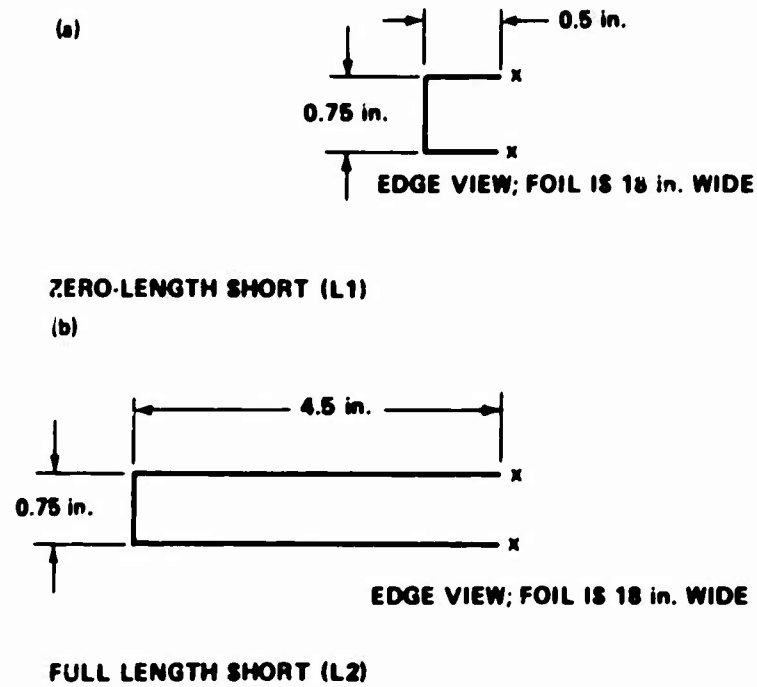
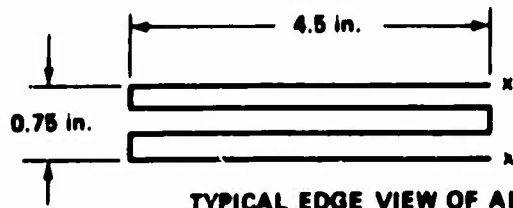
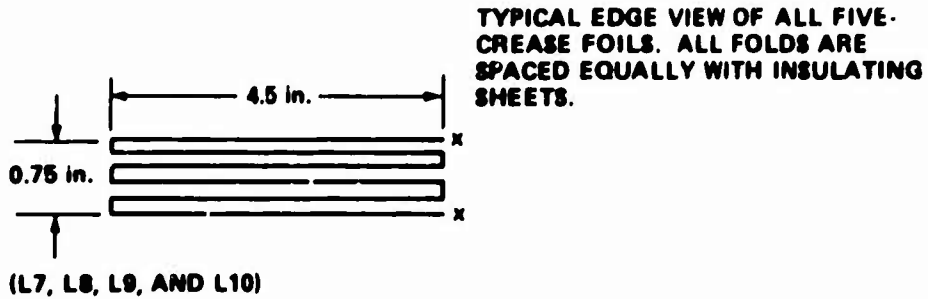

Figure 3. Baseline inductance foils.



TYPICAL EDGE VIEW OF ALL THREE-CREASE FOILS. ALL FOLDS ARE SPACED EQUALLY WITH INSULATING SHEETS. (L3, L4, L5, AND L6)

Figure 4. Three-crease folded foils.



TYPICAL EDGE VIEW OF ALL FIVE-CREASE FOILS. ALL FOLDS ARE SPACED EQUALLY WITH INSULATING SHEETS.

(L7, L8, L9, AND L10)

Figure 5. Five-crease folded foils.

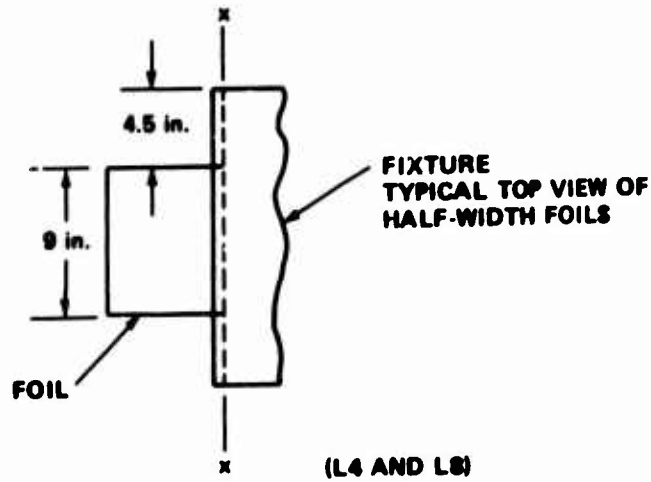

(L4 AND L8)

Figure 6. Half-width foils.

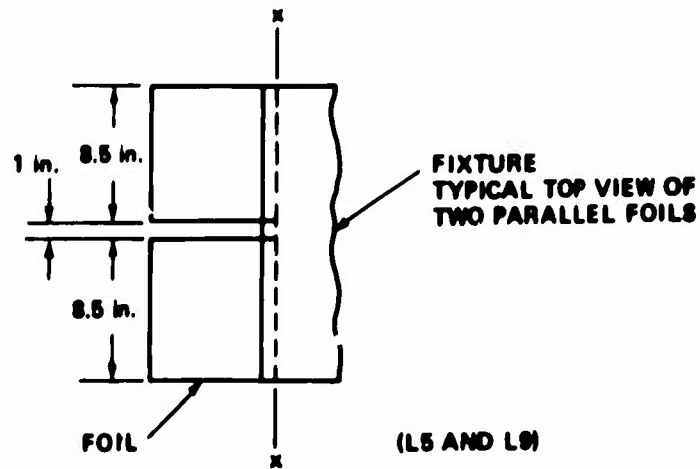

Figure 7. Two-parallel foils.

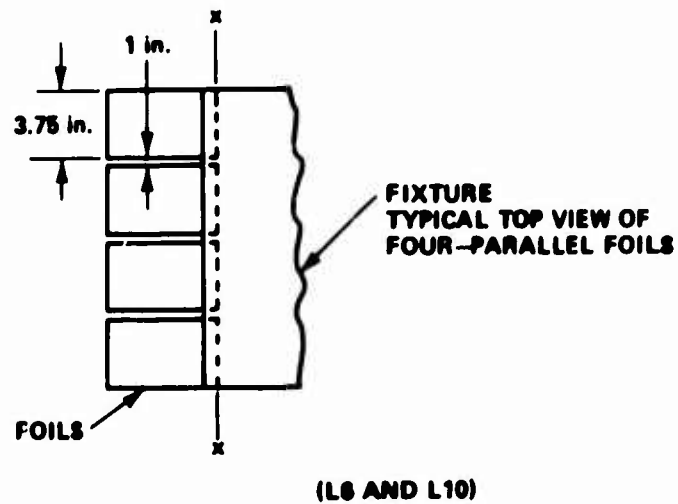

Figure 8. Four-parallel foils.

4. Results

Data were obtained for the eleven configurations and the raw values are listed in the Appendix. All of these values are in nanohenries and include experiment fixture inductance. The zero-length short (L1) is considered that configuration with least inductance so all other configurations are normalized to L1. The full-length short (L2) is considered to be a short at the end of a plate-line which is longer by the length of the foil-package. This inductance should be the highest of all full width configurations. Therefore all inductance values (except L4 and L8 which are half-width foils) should fall between L1 and L2. For an extreme of foil length, the 45-crease package was

included. This (L11) should approach the limiting value of inductance for full-width single foils. These three inductances (L1, L2, and L11) are considered as baseline quantities since they bracket the expected range of values.

Processing of the measured values consisted of taking the simple mean of the measurements for L1. This value is then subtracted from each value measured for the different trials of each foil configuration. The simple mean was then taken for each foil configuration which results in an inductance value normalized to L1.

The values derived are presented in chart form in Figure 9. It may be seen that L1 and L2 do indeed bracket all full-width inductances. In general, the paralleled foil strip configurations were higher inductances than the full width single foil. An estimation of the inductance that might be expected for the parallel strips might be made by calculation of parallel strips based on the inductance values measured for half-width foil packages (L4 and L8). For the two-parallel configurations the inductance of the 9-inch wide foils was considered to be approximately that of an 8.5-inch foil of similar configuration. For the four-parallel configurations the ratio of 18-inch wide inductance to 9-inch wide inductance was used as a multiplier for the 9-inch wide measurement to arrive at an approximate value for the inductance of a single foil. These calculated values and the measured values are shown in Table 1.

It can be seen by comparison of the calculated and measured inductances that the actual inductance is always less than the value calculated. This effect is most probably due to the partial cancellation of magnetic fields in the gap between the paralleled foils. This is illustrated in Figure 10 which shows end-view of two-parallel foils and the field lines. Figure 10(a) shows the field about a single foil. With current flowing into the page the field lines surround the foil in ellipses of increasing size and circularity as distance from the foil becomes large. This results in a field-line crowding at the edges of the foils. In Figure 10(b), two paralleled closely-spaced foils are shown. The area between the adjacent edges of the foils is occupied by opposing magnetic field lines. One set is produced by the left-hand foil and one set by the right-hand foil. The field lines oppose and thereby cancel in this area producing a decrease in inductance from that value calculated by considering only foils paralleled with no mutual coupling. The total external magnetic field lines blend together in the cancellation area, thus forming a family of ellipses encircling both foils having a "pinched-in" area at the region between the foils. If the separation between foils is made very small the "pinching" will diminish so that the field lines (and thus inductance) approach that of a single wide foil.

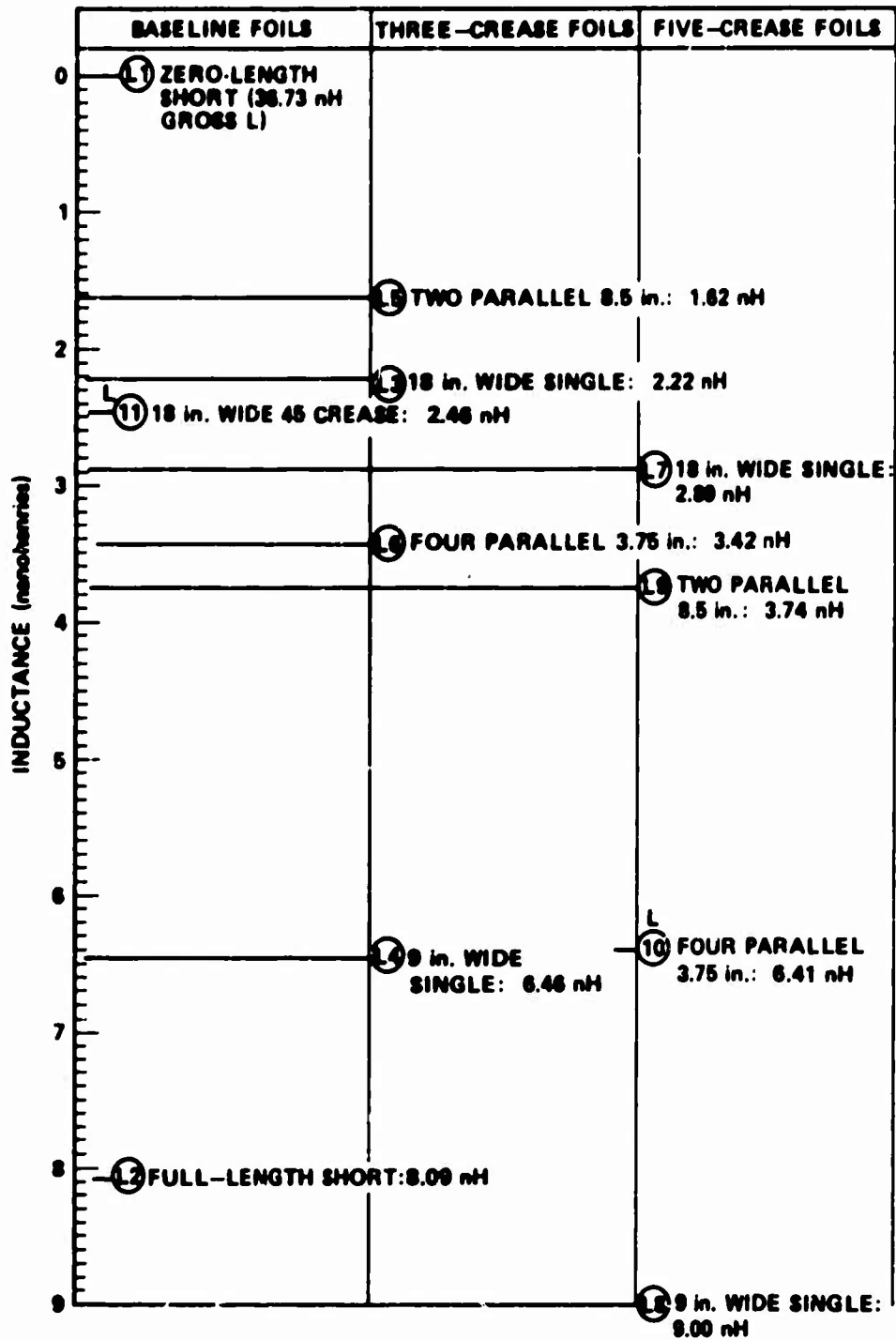

Figure 9. Foil inductance normalized to L1.

TABLE 1. COMPARISON OF CALCULATED AND MEASURED FOIL INDUCTANCES

Three-Crease Foil Inductances	Five-Crease Foil Inductances
Two parallel	Two parallel
Calculated 3.23 nH	Calculated 4.50 nH
Measured (L5) 1.62 nH	Measured (L9) 3.74 nH
Four parallel	Four parallel
Calculated 4.70 nH	Calculated 7.01 nH
Measured (L6) 3.42 nH	Measured (L10) 6.41 nH

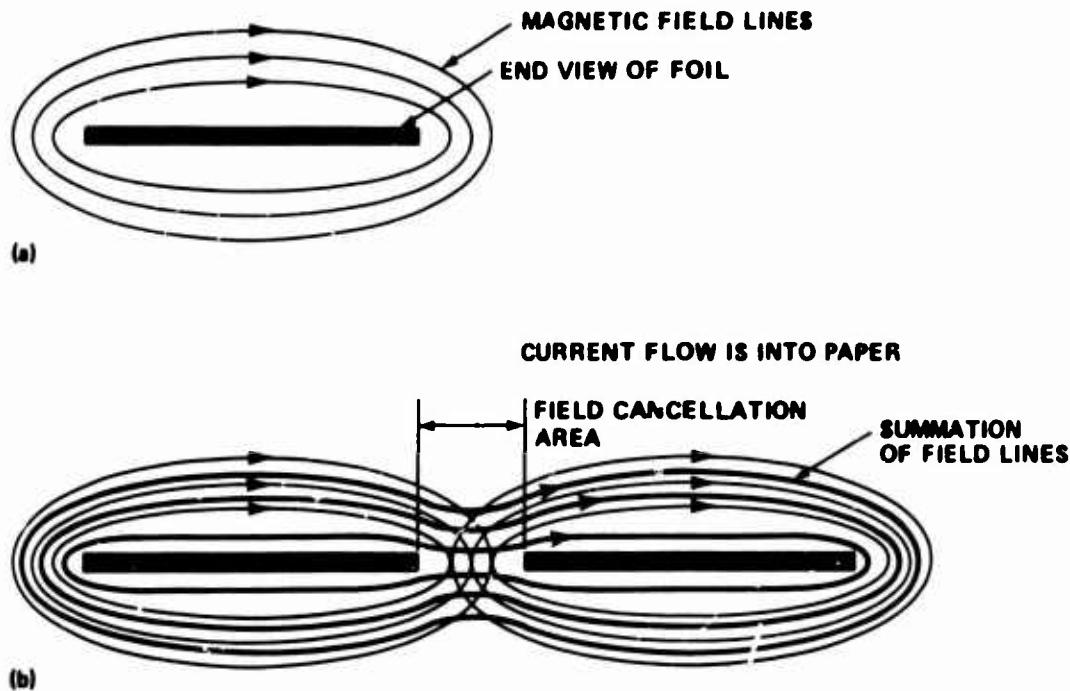

Figure 10. Magnetic field lines about current-carrying foils.

Most impressive was the fact that the forty-five-crease foil (L11) did indeed behave as predicted in approaching an inductance value of a short located half-way between the "upstream" and "downstream" ends of the foil package. A comparison of values measured and calculated are shown in Table 2. Another very impressive item is the variation in length of foil possible for a negligible variation of inductance. For instance, the forty-five-crease foil package is almost 12 times as long

as the three-crease package but they have approximately the same inductance values. This is an effect which is highly desirable for arriving at low-inductance long path-length foils.

TABLE 2. COMPARISON OF INDUCTANCE VALUES AND FOIL LENGTHS

	Measured (nH)	Calculated (nH)	Foil Length (cm)
Zero-Length Short (L1):	36.73		1.91
Half-Length Short $\left[\frac{L1 + L2}{2}\right]$		40.78	12.07
Forty-Five-Crease Foil 18 in. (L11):	39.19		525.15
Five-Crease Foil 18 in. (L3):	38.95		67.95
Three-Crease Foil-18 in. (L7):	39.62		45.09
Full-Length Short (L2):	44.82		22.23

5. Conclusions

From the comparisons made for the paralleled foils it can be seen that a single wide foil may be subdivided and the inductance remain of manageable values. Such subdividing may be required to stabilize the current paths and thereby the resistance change characteristic of an actual exploding foil.

In this experiment the foils were inductance models only and were not subjected to an exploding-current pulse. The inductance values measured are, however, seen in a real exploding foil and can have a marked effect on the impulse power source. Since the current path remains the same as the initial path throughout the foils' explosion, the inductance will remain constant. It is, of course, assumed that the required electrical action is completed before any physical disruption produced by the expanding vaporized foil takes place. This has been done by the referenced experimenters^{3,4} at long pulse-widths. The results of this study show good fit of measured foil package inductances with the expected behavior and imply that it is indeed possible to use foils of long length in low-inductance circuits. This would make possible the design of a shunt-opening switch for use in very high voltage, fast risetime impulse circuitry.

³DiMarco and Burkhardt, loc. cit.

⁴Early and Martin, loc. cit.

Appendix. RAW DATA FROM INDUCTANCE MEASUREMENTS

All inductances are in nanohenries as measured with Boonton L/C meter model 700A with 1 MHz signal.

(L1) Zero-length short

36.9	37.1	37.2	35.9	36.1
37.4	37.3	37.0	35.8	
38.8	36.8	36.9	36.3	

(L2) Full-length short

44.9	45.1	45.0	45.0	44.7	45.0	44.5
45.1	45.0	44.9	44.5	44.5	44.6	44.6
45.0	44.9	45.0	44.6	44.8	45.0	44.5

(L3) Three-crease, 18 in. wide

38.6	38.8	39.3	38.8	38.9
39.2	39.0	39.2	39.0	38.9
38.7	38.9	36.9	39.1	

(L4) Three-crease, 9 in. wide

43.6	43.7	42.9	43.1	42.9
43.5	43.8	43.1	42.5	43.1
43.5	43.4	42.8	43.0	43.0

(L5) Three-crease, two parallel 8.5 in.

38.4	38.5	38.3	38.3	38.5	38.3
38.5	38.3	38.4	38.3	38.2	38.4
38.4	38.2	38.1	38.4	38.5	

(L6) Three-crease, four parallel 3.75 in.

40.2	40.4	40.2	40.1	40.1
40.3	40.3	40.2	40.0	40.0
40.1	40.3	40.0	39.9	

(L7) Five-crease, 18 in. wide

39.1	39.2	39.7	39.7	39.9	39.8
39.2	39.0	39.8	39.9	39.9	39.9
39.3	39.6	39.6	39.8	40.0	39.8

Preceding page blank

(L8) Five-crease, 9 in. wide

45.1	46.2	45.7	45.1	45.8	45.8	45.4
46.1	46.0	46.1	45.2	46.1	45.7	45.5
45.9	45.2	46.0	45.9	46.0	45.8	45.8

(L9) Five-crease, two parallel 8.5 in.

40.9	40.6	40.5	40.0	40.4	40.5	40.3
41.0	40.4	40.4	40.3	40.6	40.4	
40.5	40.3	40.4	40.5	40.5	40.5	

(L10) Five-crease, four parallel 3.75 in.

42.9	43.4	43.2	43.5	43.5	43.1	42.9	43.1
43.0	43.6	43.0	43.1	43.4	43.0	43.0	43.0
43.1	43.1	43.4	43.2	43.0	43.0	42.9	42.9

(L11) Forty-five-crease, 18 in. wide

39.2	39.4	39.5	39.5	38.9	39.1	39.1	39.1
39.0	39.2	39.4	39.0	39.2	39.0	39.2	
39.1	39.6	39.3	39.0	39.3	39.0	39.1	