

LWL
CR-04P72
c. 1

TECHNICAL REPORT LWL-CR-04P72

LAND VEHICLE NAVIGATION SYSTEM

by

D. G. Kadron
C. R. Younkin
Westinghouse Electric Corp
Systems Development Division
Baltimore, MD 21203

TECHNICAL LIBRARY
BLDG. 305
ABERDEEN PROVING GROUND, MD.
STEAP-TL

15 April 1974

Final Report

APPROVED FOR PUBLIC RELEASE; DISTRIBUTION UNLIMITED

U. S. ARMY LAND WARFARE LABORATORY

Aberdeen Proving Ground, Maryland 21005

20081022 014

LWL
CR-04P72
c. 1

The findings in this report are not to be construed as an official Department of the Army position unless so designated by other authorized documents.

UNCLASSIFIED

SECURITY CLASSIFICATION OF THIS PAGE (When Date Entered)

REPORT DOCUMENTATION PAGE		READ INSTRUCTIONS BEFORE COMPLETING FORM
1. REPORT NUMBER LWL-CR-04P72	2. GOVT ACCESSION NO.	3. RECIPIENT'S CATALOG NUMBER
4. TITLE (and Subtitle) Land Vehicle Navigation System		5. TYPE OF REPORT & PERIOD COVERED
		6. PERFORMING ORG. REPORT NUMBER
7. AUTHOR(s) D. G. Kadron C. R. Younkin		8. CONTRACT OR GRANT NUMBER(s) DAAD05-72-C-0241
9. PERFORMING ORGANIZATION NAME AND ADDRESS Westinghouse Electric Corporation Systems Development Division Baltimore, MD 21203		10. PROGRAM ELEMENT, PROJECT, TASK AREA & WORK UNIT NUMBERS LWL Task 04-P-72
11. CONTROLLING OFFICE NAME AND ADDRESS US Army Land Warfare Laboratory Aberdeen Proving Ground, MD 21005		12. REPORT DATE April 1974
		13. NUMBER OF PAGES 128
14. MONITORING AGENCY NAME & ADDRESS (if different from Controlling Office) N/A		15. SECURITY CLASS. (of this report) Unclassified
		15a. DECLASSIFICATION/DOWNGRADING SCHEDULE N/A
16. DISTRIBUTION STATEMENT (of this Report) Approved for Public Release; Distribution Unlimited		
17. DISTRIBUTION STATEMENT (of the abstract entered in Block 20, if different from Report) N/A		
18. SUPPLEMENTARY NOTES None		
19. KEY WORDS (Continue on reverse side if necessary and identify by block number) Vehicle navigation Magnetic heading compensation		
20. ABSTRACT (Continue on reverse side if necessary and identify by block number) This report is the Final Technical report describing the development and test of a Land Vehicle Navigator (LVN). The LVN is a completely self-contained and passive navigation system which can provide accurate UTM and heading information for many Army vehicles. Real-time position, accurate to 3% of distance travelled, is provided to the vehicle commander by continuously reading out and updating 8-digit UTM		

TECHNICAL LIBRARY
BLDG. 305
ABERDEEN PROVING GROUND, MD.
STEAP-TL

CONT

coordinates. A unique compensation scheme which corrects for magnetic disturbances affecting the compass provides automatic operation with no requirements for external equipment compass rose or knowledge of compass directions when calibration is required.

Two LVN prototypes were designed, fabricated and tested for use with M113 and M151 vehicles. These systems are scheduled for MASSTER tests at Ft. Hood, TX in 4th Qtr FY 74. An additional effort to develop and design a technique to adapt this system to Army tanks has been successfully accomplished and is described in the Appendix of this report.

FOREWORD

This effort was sponsored by the US Army Land Warfare Laboratory, Advanced Development Division, Applied Physics Branch under the technical supervision of Carey L. Weigel. The project was designated 04-P-72, Land Vehicle Navigation System.

Special notation is made to the Appendix of this report wherein a determination of the complex magnetic effects associated with an Army tank has been accomplished and a solution to semi-automatically compensate these effects has been proposed.

The magnetic disturbance analysis and development of the compensation techniques herein have been made possible largely through the relentless efforts of John Mattern, Fellow Engineer, System Development Division, Baltimore, Maryland 21203.



TABLE OF CONTENTS

Section	Page
1.0 Summary	1-1
2.0 Introduction	2-1
2.1 Problem Analysis	2-2
2.2 Proposed Solution	2-20
3.0 System Operation	3-1
4.0 System Design	4-1
4.1 Compass	4-1
4.1.1 Detailed Description	4-3
4.1.2 Sensor Card	4-7
4.2 Processor	4-7
4.2.1 Compass Processor	4-7
4.2.1.1 The AGC Amp/Filter	4-10
4.2.1.2 Phase Detector	4-10
4.2.2 The Clock Generator and Core Drive	4-11
4.2.2.1 Clock Generator	4-11
4.2.2.2 Core Drive	4-13
4.2.3 Resolver	4-13
4.2.4 North and East Channel Card	4-15
4.2.5 Distance Increment and Control Card	4-19
4.2.5.1 Slew Control	4-19
4.2.5.2 Distance Increment Input Circuit	4-22
4.2.6 The Calibrate Circuitry	4-22
4.2.6.1 Detailed Description	4-23
4.2.7 Power Supply	4-27



TABLE OF CONTENTS

Section	Page
4.3 Display and Control Unit	4-27
4.4 Heading Indicator	4-30
5.0 Mechanical Design	5-1
5.1 Compass and Compass Mount	5-1
5.2 Display and Control Unit	5-1
5.3 Heading Indicator	5-1
5.4 Processor	5-1
6.0 Tests	6-1
6.1 Test Philosophy	6-1
6.2 Lab Tests	6-1
6.3 Field Tests	6-1
7.0 Application for Other Vehicles	7-1
7.1 Jeep	7-1
7.2 Proposed Solution	7-4
7.3 Tank	7-8
8.0 Conclusions and Recommendations	8-1
APPENDIX A: Tank Compensation and Design Plan	A1



LIST OF ILLUSTRATIONS

Figure		Page
1	Land Vehicle Navigation System	viii
2	Vehicle Navigator Mounted on APC	ix
2-1	Orthogonal Sensor Probes.....	2-4
2-2	Heading Circle for Undisturbed Compass.....	2-5
2-3	Longitudinal Disturbance.....	2-6
2-4	Heading Circle Plot with Horizontal Longitudinal Disturbance.....	2-7
2-5	Heading Circle with Disturbance Showing East Error.....	2-9
2-6	Disturbance Errors.....	2-10
2-7	Lateral Disturbances.....	2-11
2-8	Diagonal Disturbance.....	2-12
2-9	Vertical PM Disturbance.....	2-14
2-10	Horizontal Longitudinal Soft-Iron Disturbance.....	2-15
2-11	Heading Circle with Soft-Iron Disturbance.....	2-16
2-12	Lateral Soft-Iron Disturbance.....	2-17
2-13	Asymmetrical Soft-Iron.....	2-19
2-14	Lateral Symmetrical Soft-Iron Disturbance.....	2-20
2-15	General PM Disturbance.....	2-22
3-1	Display and Control Unit.....	3-2
3-2	Heading Indicator.....	3-3
4-1	Block Diagram of Compass and Processor.....	4-2
4-2	Compass Drawing.....	4-4
4-3	Sensor Element.....	4-5
4-4	LVN Compass.....	4-6
4-5	Compass Schematic.....	4-8
4-6	Compass Processor.....	4-9
4-7	Clock Generator and Core Drive.....	4-12
4-8	Flux Gate Waveform Diagram.....	4-14
4-9	Resolver Block Diagram.....	4-16
4-10	Resolver Timing Diagram.....	4-17
4-11	Channel Logic.....	4-20
4-12	Distance Increment and Control Card.....	4-21
4-13	Calibrate Start Circuit.....	4-24
4-14	Calibrate Circuit.....	4-25
4-15	Calibrator Timing Diagram.....	4-26
4-16	Power Supply Card.....	4-28
4-17	Display and Control Unit.....	4-29
4-18	Heading Indicator Schematic.....	4-31



LIST OF ILLUSTRATIONS

Figure		Page
5-1	Compass and Compass Mount.....	5-2
5-2	Compass Mounted on APC.....	5-3
6-1	Heading Circle Without Disturbance Present....	6-2
6-2	Heading Circle with Disturbance.....	6-3
6-3	Disturbance Measured on APC.....	6-5
6-4	Heading Circle on APC Before and After Calibration.....	6-6
6-5	APG Course Data #1.....	6-7
6-6	APG Course Data #2.....	6-8
6-7	APG Course Data #3.....	6-10
6-8	APG Course Data #4.....	6-11
6-9	APG Course Data #5.....	6-12
6-10	Disturbances Measured on Two APC's Fort Knox, Kentucky.....	6-13
6-11	Fort Knox Course Data.....	6-14
7-1	Jeep Heading Circle with Disturbance.....	7-2
7-2	Jeep, When Calibrated.....	7-3
7-3	Automatic Soft-Iron Compensation.....	7-6
7-4	General PM Disturbance with Soft-Iron.....	7-7
7-5	Disturbance 2X Earth's Field.....	7-9
7-6	Disturbances Measured on Tank.....	7-10
7-7	Tank Disturbances Cont.....	7-11



FIGURE 1. LAND VEHICLE NAVIGATION SYSTEM

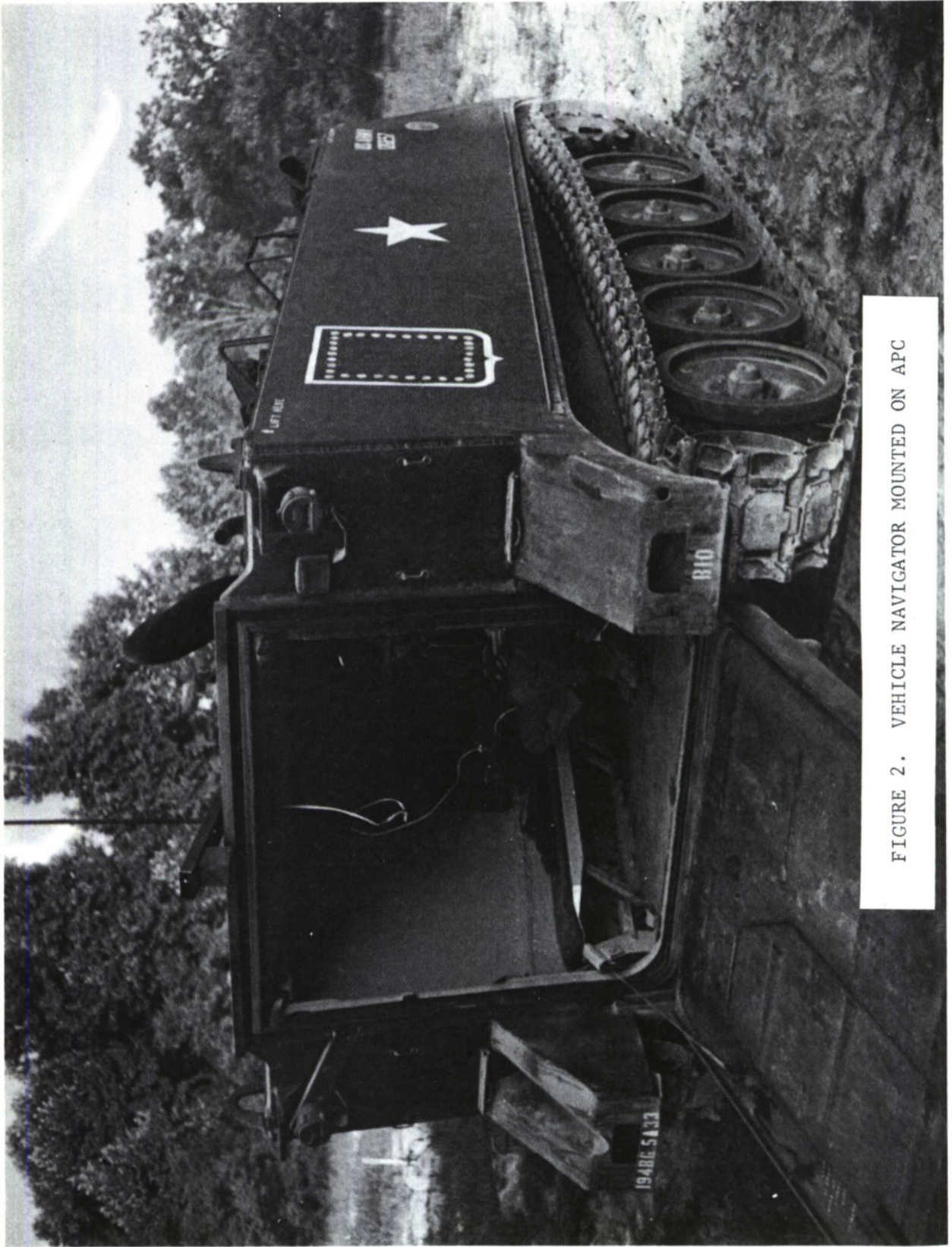

FIGURE 2. VEHICLE NAVIGATOR MOUNTED ON APC



1.0 SUMMARY

This is the final technical report for contract DAAD05-72-C-0241 describing a one year program to develop a Land Vehicle Navigation System.

The Land Vehicle Navigator (LVN) developed on this contract is a completely self-contained dead-reckoning vehicle navigation system that uses a flux-gate electronic compass and the vehicle odometer data to automatically and continuously compute and display the real-time position of the vehicle in standard military 8 digit coordinates.

The LVN, shown in Figure 1, consists of a compass, a processor, a display and control unit, and a heading indicator. The compass mounts flush with the outside rear of an Armored Personnel Carrier (APC) (Figure 2). The compass is connected by means of a cable to the processor which can be carried in any convenient position inside the vehicle. Attached to the processor is the display unit which continuously reads the real-time position of the vehicle. Also attached to the processor is a heading indicator unit which can be mounted in the driver's compartment.

The LVN is unique in that it possesses the capability of automatically compensating for magnetic perturbations caused by magnetic material on the vehicle. Any permanent magnetic material on the vehicle (torsion bars, motors, etc.) or any magnetic equipment carried (tow chains, guns, ammunition, tools, etc.) can be automatically compensated for by driving the vehicle slowly in a small circle. The LVN measures the magnitude of any disturbance and applies a compensating feedback. Should the magnetic load shift during vehicle use, recompensation can be performed quickly at any time in the field without any additional alignment equipment (such as gyroscopes, compasses, etc.) and without any knowledge of direction.

Two breadboard LVN Systems were designed, fabricated and tested on APC's. Tests were run both at Aberdeen Proving Ground and at Fort Knox, Kentucky. Three different APC's were automatically calibrated in the field using no additional test equipment. One of the APC's carried complete combat gear including a machine gun, tow chains, tools, etc. Both on and off-the-road tests were run at Fort Knox under diverse terrain conditions including winding dirt roads, cross country trails, and steep grades. On all these tests an average position location accuracy of within 2.5% of the distance travelled was achieved.



Because of the success of the system on the APC's, an additional out-of-scope measurement program was performed on a jeep and a tank to determine the system potential for these vehicles. Road tests on the jeep showed accuracies of from 2 to 5%. The higher error with a jeep was shown to be caused by the presence of longitudinal horizontal soft-iron for which the LVN, in its present form, does not compensate. Similarly, the measurement of one M48 tank also indicated the presence of very large disturbances and excessive soft-iron. A modification to the system to automatically correct for horizontal soft-iron disturbances is proposed in Section 7.2 of this report. Once this modification is made, accuracies of 1% on jeeps and 3% on tanks are anticipated.

Westinghouse recommends that, in light of the success of the present effort, further work be done with the LVN. Additional effort could well be applied to the electronic soft-iron compensation technique proposed herein, and, additional test measurements should be performed on tanks and jeeps. Following the success of this effort, an all-vehicle prototype model or models could be built for extensive Army testing.

All present indications are that the low-cost, simplicity and ruggedness of a magnetic system could offer considerable short term and long term cost savings over the gyroscopic approaches to the vehicle navigation problem.



2.0 INTRODUCTION

The simplicity, efficiency, small size, and reliability of the magnetic compass have made it an ever-present and invaluable aid to navigation since its conception. With the advent of electronic compasses, the potential of magnetic heading sensing systems has increased since such techniques remove the need for human interpretation of the raw heading information, thereby allowing faster and more accurate use of this data.

The limiting factor on the accuracy of a magnetic heading sensor frequently lies in the anomalies in the magnetic field that is sensed. Often the anomalies caused by magnetic materials carried on the navigating vehicle itself are the principal sources of error. Elaborate methods of measurement, de-Gaussing, and compensation have been devised to correct inaccuracies caused by this type of perturbation. Where errors cannot be corrected, tabulations of deviations are often made to be used to correct the compass reading to the true magnetic heading.

The principal difficulty with such correction measures is that the perturbations can change with time and use of the vehicle.

The magnetic properties of metal structures depend on the type and history of the material. The orientation of the material when it is formed and shaped often accounts for its characteristics. Any violent forming operations such as heating, forging, welding, riveting, etc., can influence the magnetic domains of the material, tending to align them with the local external field at the time. If these effects tend to remain over long periods of time, with the material retaining a magnetism, the material is called magnetically "hard". If any magnetism present in an external field tends to disappear upon removal of the field, the material is designated "soft".

Even permanently magnetized hard materials tend to vary with their history. Ships, when struck by lightning, when undergoing extensive refitting and material changes, when sitting in port with a fixed heading for extensive periods, or even when holding a fixed course for long durations, often experience changes in their magnetic characteristics requiring a recalibration of their compasses. Less data is available for land vehicle navigation systems, but there is no reason to suppose them to be any different. The constant



shock and vibration of road vehicles particularly of the tracked variety, may well affect the long-term magnetic characteristics of the vehicle disturbances. If frequent recalibration is necessary and, if the recalibration procedures are elaborate, requiring extensive test equipment or special test areas, this can be a serious drawback for the system. The LVN program was conceived as an effort to study the magnetic perturbations caused by Armored Personnel Carriers to magnetic heading sensors, and to evolve and implement a system that would automatically account for heading sensor perturbations caused by the magnetic disturbances on the vehicles.

The effort was based on previous navigation experience with man-carried navigation systems, namely, the Improved Position Locator, AN/PSN-5 and the Land Navigator, AN/PSN-7. These programs developed a highly accurate electronic flux gate compass and the necessary processing techniques to automatically combine heading and distance information in order to derive position location coordinates. All of these efforts were funded by the Land Warfare Laboratory at Aberdeen Proving Ground, starting with the AN/PSN-5 in 1968 and followed by the AN/PSN-7 in 1971. In an effort to minimize costs for developing the LVN, all the technology and some hardware from the previous programs were used. The main LVN processor chassis was a modified AN/PSN-5 as was the processing and the display unit. The LVN flux gate compass technology was derived from the AN/PSN-7.

2.1 PROBLEM ANALYSIS

The vehicle-carried anomalies can be sorted into two groups, i.e., those caused by "hard" iron (more or less permanently magnetized material) and those caused by "soft" iron (material that loses its magnetism when not in an external magnetic field). In addition, most disturbances can be sorted into equivalent simplified disturbances by considering the physical placement of the disturbance, i.e.; is it like a horizontal dipole magnet, or vertical; is it longitudinal (along the length) or lateral (along the width); is it symmetrically placed along the axis of the compass, or asymmetrical. Each of the various types of disturbances has a clearly discernible effect on the compass heading accuracy.



The effects of each type of disturbance can be most easily analyzed by the use of a heading circle plot. This plot assumes that the vehicle heading vector at any instant is derived from the outputs of two orthogonal sensors, A and B, whose outputs are voltages proportional to the magnitude of the component of the magnetic field in line with the sensor, and positive or negative depending on the direction of the field (See Figure 2-1). The probe heading, defined as the angle θ , is the direction in which sensor A points. The arrows on the sensors show the field direction for a positive output. The outputs of the probes can be defined as:

$$2.1.1 \quad A = H_e \cos \theta$$

$$2.1.2 \quad B = H_e \cos (\theta - 90) = H_e \sin \theta$$

where H_e is the magnitude of the horizontal component of the earth's field, H_e is normalized to equal "1" in the following.

If these outputs are plotted with A as the ordinate and B as the abscissa for all values of θ , the result is a heading circle plot (Figure 2-2). Thus when the probe points north ($\theta = 0^\circ$), $A = +1$, $B = 0$. At 45° , $A = B = .707$, which is northeast. For south $A = -1$, $B = 0$, etc.

If the probe is now placed on a vehicle with a local magnetic disturbance which rotates with the vehicle, the heading circle plot will change. Assume the disturbance is a horizontal longitudinal permanent magnet (PM) in front of the compass as shown in figure 2-3. When the vehicle points north, the disturbance adds to the earth's field causing the output of sensor A to increase but having no effect on sensor B (zero output). The output of sensor A will be increased by the relative magnitude of the disturbance compared to the earth's field. In fact, the output of A will be increased by the magnitude of the disturbance regardless of the heading, or

$$2.1.3 \quad A = H_e \cos \theta + H_D$$

Sensor B, always perpendicular to the disturbance, will remain unchanged, or,

$$2.1.4 \quad B = H_e \sin \theta$$

The heading circle plot will thus be a circle that is displaced by an amount equal to the magnitude of the disturbance. (Figure 2-4)

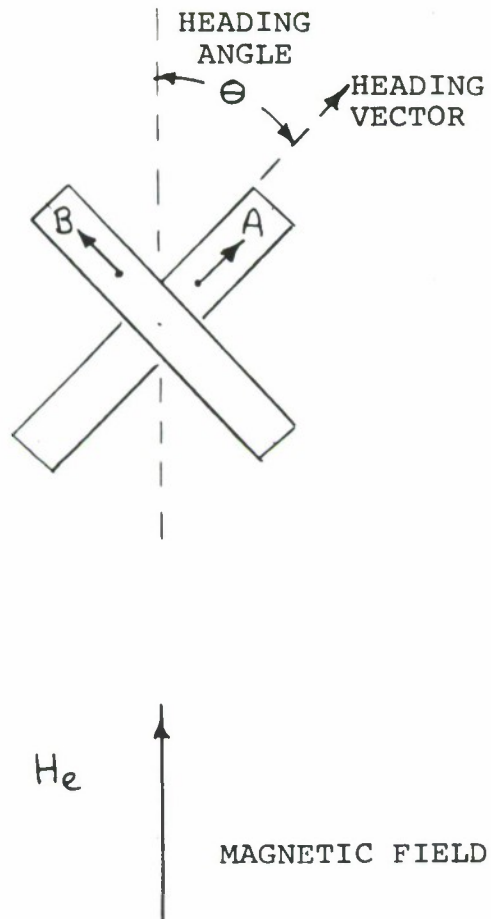

FIGURE 2-1 ORTHOGONAL SENSOR PROBES

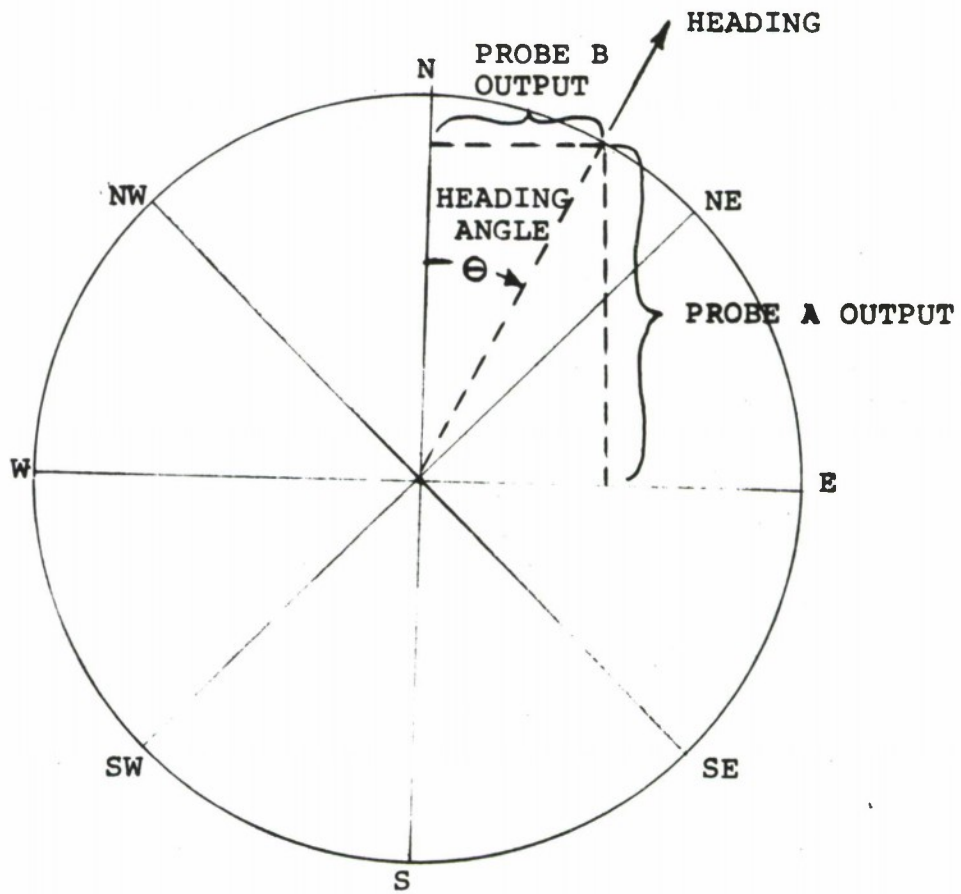

FIGURE 2-2 HEADING CIRCLE FOR UNDISTURBED COMPASS

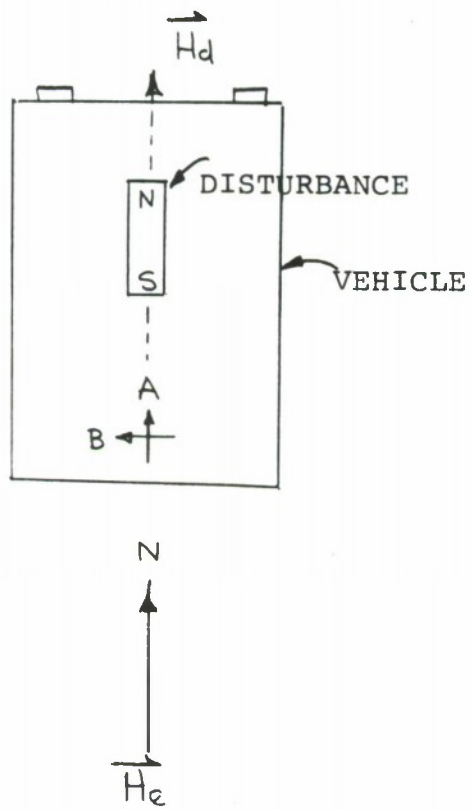

FIGURE 2-3 LONGITUDINAL PM DISTURBANCE

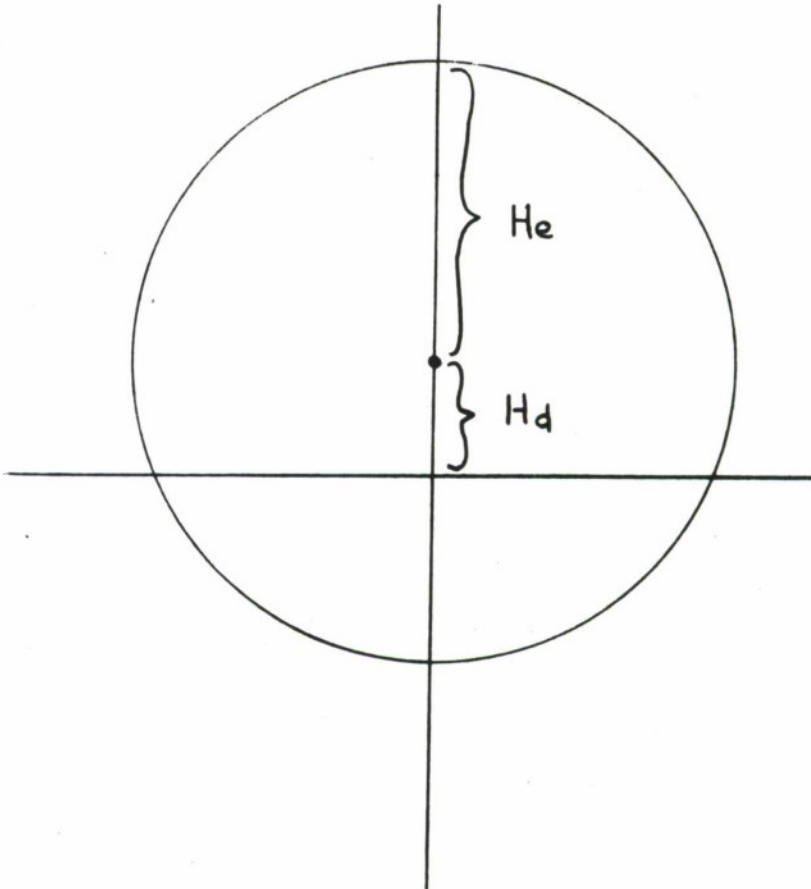

FIGURE 2-4 HEADING CIRCLE PLOT WITH
HORIZONTAL LONGITUDINAL
DISTURBANCE

The error caused by the disturbance will vary depending on the heading angle θ . The system processor will normally take the heading to be the angle $\alpha = \text{arc tan } B/A$ (See Figure 2.5). Thus for north ($\theta = 0^\circ$) and for south ($\theta = 180^\circ$), the error will be zero since $\text{arc tan } 0 = 0^\circ$ or 180° .

For east, or $\theta = 90^\circ$, the error will be the difference between α and θ (90°).

$$2.1.5 \quad \alpha = \text{arc tan } B/A = \text{arc tan } H_e/H_d$$

In general the system will interpret the heading to be

$$2.1.6 \quad \alpha = \text{arc tan } \left\{ \frac{H_e \sin \theta}{H_e \cos \theta + H_D} \right\}$$

which can be thought of as the projections onto a normalized circle of the θ points of the disturbed circle. This is shown in Figure 2-6 for the cardinal and intercardinal headings. By comparing these points to where they would lie if the dotted circle were the normal heading circle, one can obtain a graphical idea of the errors caused by the disturbance. Thus, since the N and S are still on the ordinate of the plot, the error is zero for these headings. The east point E lies to the north of the abscissa where it should be, showing the error to be the angle Δ . All the other points are pulled more or less to the north. Recalling that the disturbance was a dipole whose field was north when the vehicle was pointed north allows a general rule to be developed, i.e., the errors caused by a north/south disturbing dipole will act to pull the heading circle points in the direction of the disturbance field.

If the disturbance field is equivalent to a lateral dipole as shown in Figure 2-7a, only sensor B will be affected by its field. The effect will be to displace the heading circle points to the West and the errors will be as shown in Figure 2-7b. A similar result occurs in Figure 2-7c.

Any horizontal permanent-magnet dipole disturbance can be thought of as having longitudinal and traverse components. The effect on the accuracy can be analyzed as before. The heading circle is displaced in the direction of the dipole field in the north/south and in the opposite direction in the east/west. Such a case is shown in Figure 2-8.

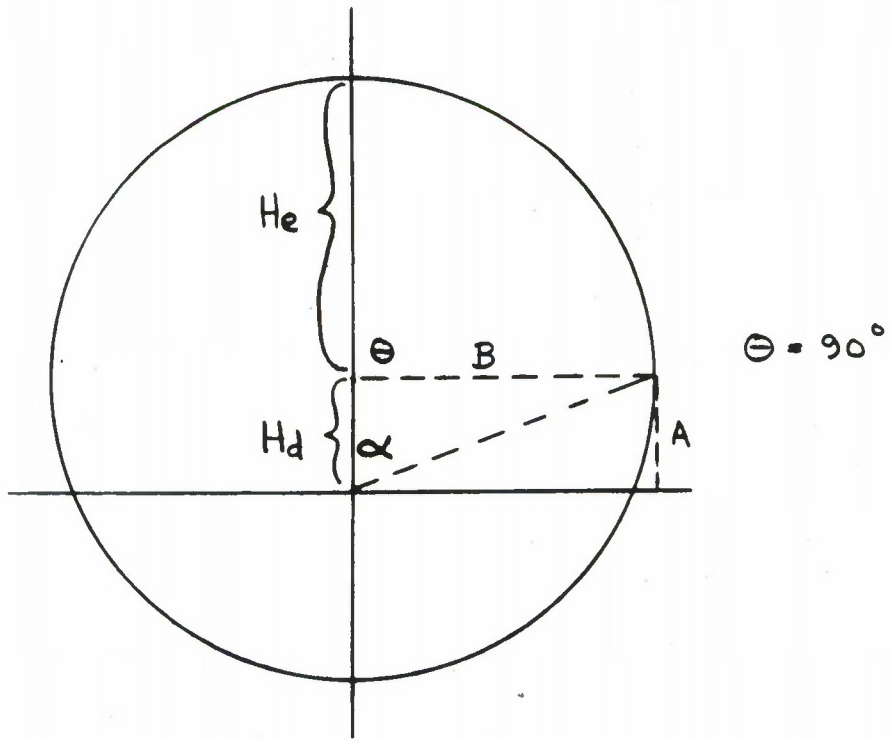

FIGURE 2-5 HEADING CIRCLE WITH DISTURBANCE SHOWING EAST ERROR

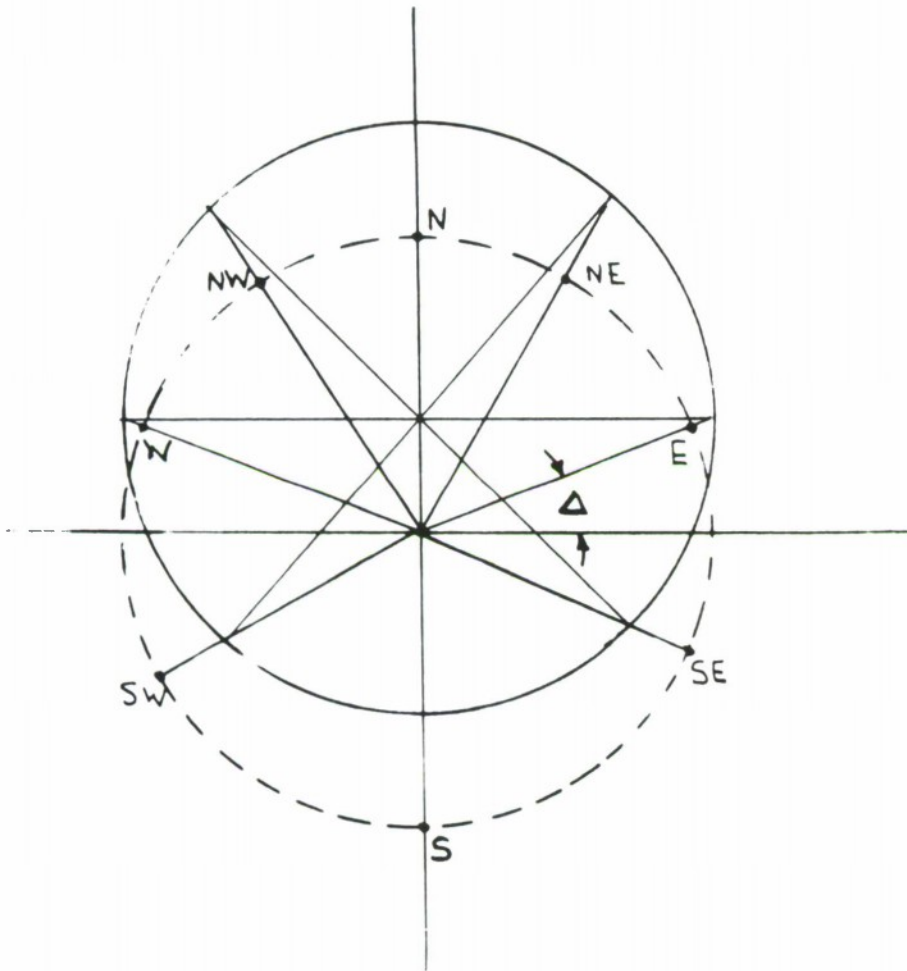
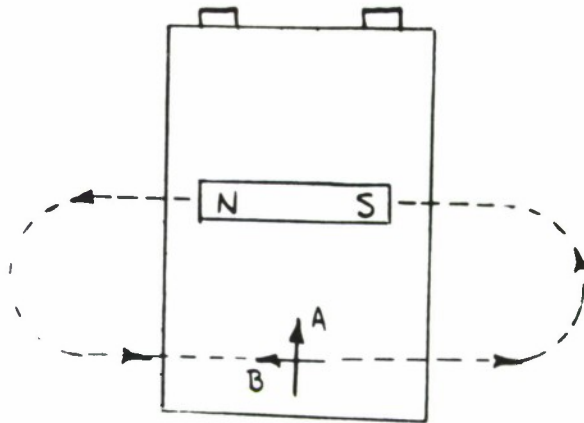
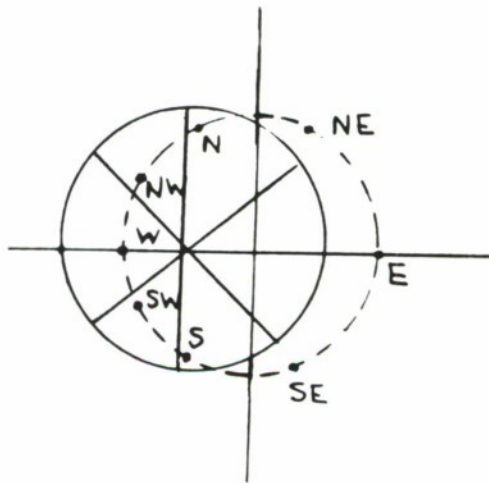

FIGURE 2-6 DISTURBANCE ERRORS



a.
LATERAL DISTURBANCE



b.
HEADING CIRCLE

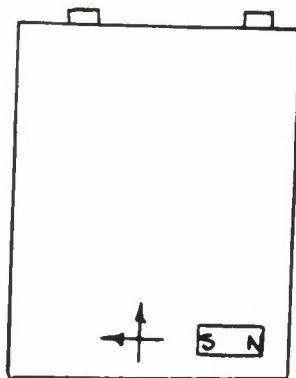

c.
EQUIVALENT CASE

FIGURE 2-7 LATERAL DISTURBANCES

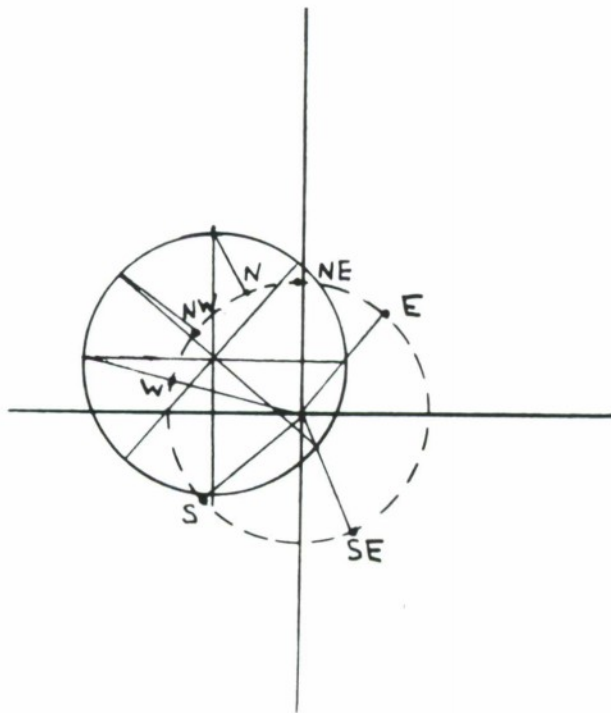
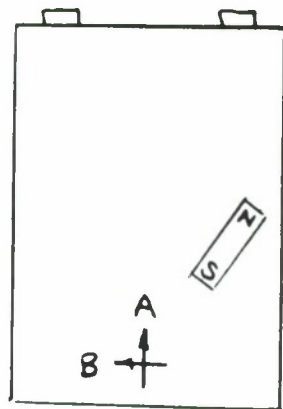

FIGURE 2-8 DIAGONAL DISTURBANCE



A horizontal dipole whose axis does not lie on the probe axis can be equated to two dipoles that are on the axis.

If the permanent magnet disturbance is vertical, its effect depends on whether it is symmetrical or not with the probe. The disturbance in Figure 2-9a is symmetrical in that its north and south poles are equidistant from the probe, thus having no net pull. In Figure 2-9b, the north pole dominates. This case is equivalent to a smaller horizontal dipole placed at the position of the north pole.

Two important factors evolve from this discussion. The first is that, by measuring the errors in heading for different headings, some conception of the type of permanent magnet disturbance can be obtained. The second is that all PM disturbances, horizontal or vertical, can be equated to a single longitudinal and a single lateral disturbance, and corrected as such.

In addition to PM disturbances, errors in heading occur due to soft iron present on the vehicle. Figure 2-10 shows a piece of longitudinal soft-iron in front of the probe. When headed north, the soft-iron is magnetized so as to intensify the field without changing its direction (2-10a). Similarly when heading south the soft-iron is magnetized in the opposite sense as before and thus also intensifies the field. For east and west, a small dipole is formed across the width, but the bulk effect along the length of the rod is negligible. Effects along the width of the rod are considered lateral rather than longitudinal. On intercardinal headings the field will be intensified, but less so. Using the heading circle analysis, the locus will be an ellipse in which the major axis (north/south direction) will be increased over the normal circle diameter by twice the magnitude of the magnetized disturbance. The minor axis (east/west) will be unchanged and equal to the original circle diameter (See Figure 2-11). The errors caused by such a disturbance, as with the PM disturbances, vary with heading. However in this case, no error will occur in the cardinal directions. As can be seen from the projections of Figure 2-11, the greatest error will occur in the intercardinal directions. Northwest and northeast are pulled to the north while southwest and southeast are pulled to the south.

If the disturbance is purely a lateral soft-iron rod, and off center as in Figure 2-12, the effect will be similar but the elongations will be towards the east/west axis. From this it can be seen that a lateral soft-iron rod could be used to cancel the effects of a longitudinal soft-iron disturbance since their effects are opposite.

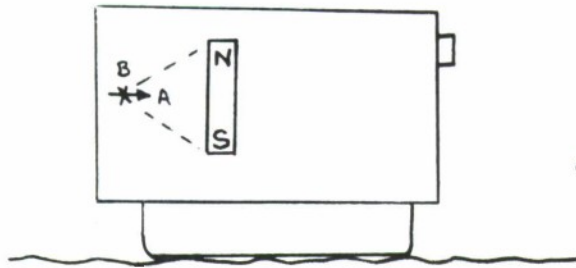

a. POLES EQUIDISTANT

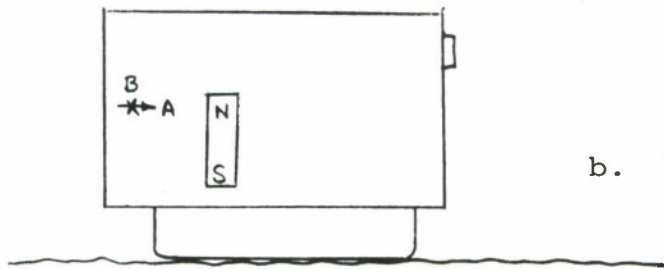

b. NORTH CLOSER

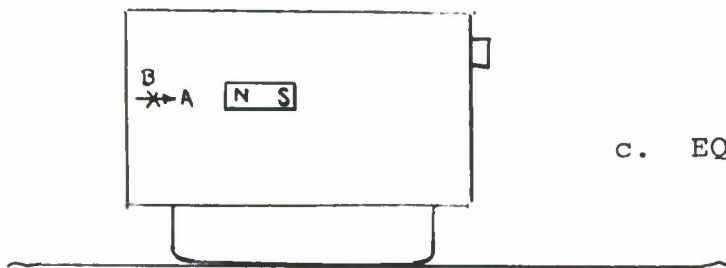

c. EQUIVALENT CASE

FIGURE 2-9 VERTICAL PM DISTURBANCE

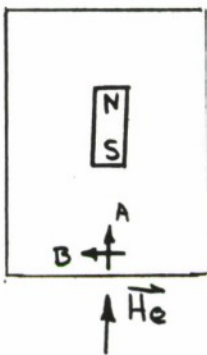

a.
NORTH HEADING

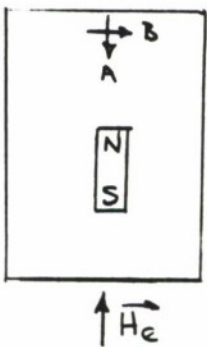

b.
SOUTH HEADING

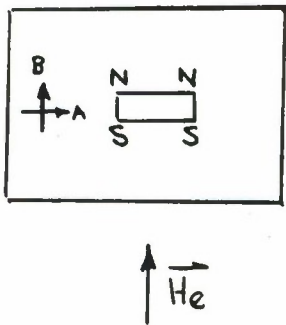

c.
EAST HEADING

FIGURE 2-10 HORIZONTAL LONGITUDINAL
SOFT IRON DISTURBANCE

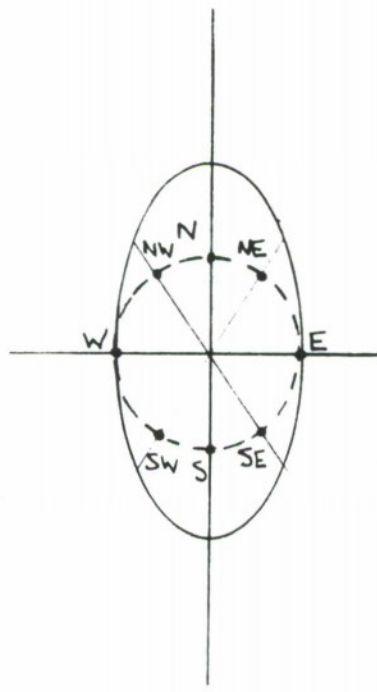

FIGURE 2-11 HEADING CIRCLE WITH SOFT IRON DISTURBANCE

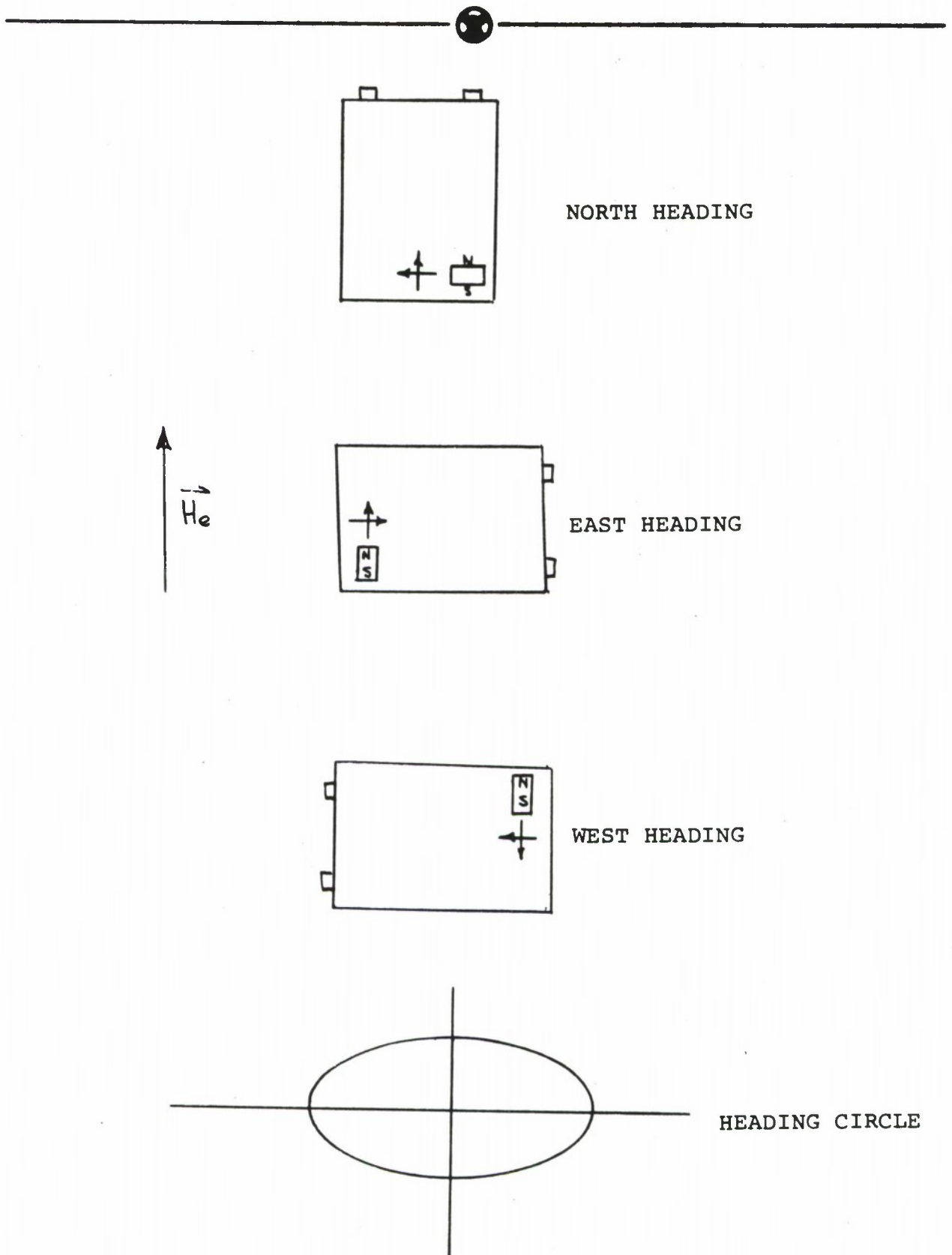

FIGURE 2-12 LATERAL SOFT IRON DISTURBANCE



Any other soft-iron disturbance whose axis goes through the probe center will have a similar effect of elongating the heading circle along the axis of the disturbance. In the north/south direction and in the opposite sense in the east/west direction. This is illustrated in Figure 2-13.

If the disturbance is lateral and symmetrical as in Figure 2-14, there will be no effect in the north and south directions. For east and west the field will be diverted, but because of the symmetry, the angle that the sensor probes see will be unchanged. The magnitude of the field will be less however due to the diversion, resulting in an ellipse as in Figure 2-14b.

Should the soft-iron be a vertical rod it will be influenced mainly by the earth's vertical field when sufficiently far from the equator for such a component to be significant. In the northern latitudes a vertical bar will become a dipole with the south pole on top and north pole on the bottom. If the two poles thus formed are equidistant from the probe, no effect on the heading will occur. Should the vertical bar be positioned so that either pole dominates, the effect will be equivalent to having a particular pole in a constant position regardless of heading, which will create the same error as a horizontal PM magnet of less magnitude.

If the soft-iron disturbance is horizontal and its axis does not go through the probe center, the field will be intensified and also diverted. To the extent that the field is intensified, the disturbance can be considered as an on-center soft-iron disturbance in the direction of the disturbance axis (in this case north/south). The field diversions can result in a decrease in intensity which can cancel the intensifications depending on the size and placement of the disturbance. What is singular in this case is that an apparent declination of the output of one probe can occur. Thus the heading circle could appear as a rotated or even a distorted ellipse.

From this discussion it can be seen that all symmetrical soft-iron disturbances can be equated to a single horizontal disturbance plus a vertical disturbance, which, in turn, can be equated to a horizontal PM disturbance. Asymmetrical disturbances can add the complication of rotating the heading circle ellipse, or just one axis of it.

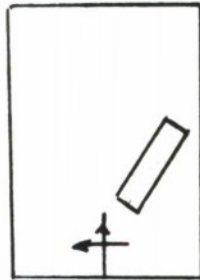

DISTURBANCE

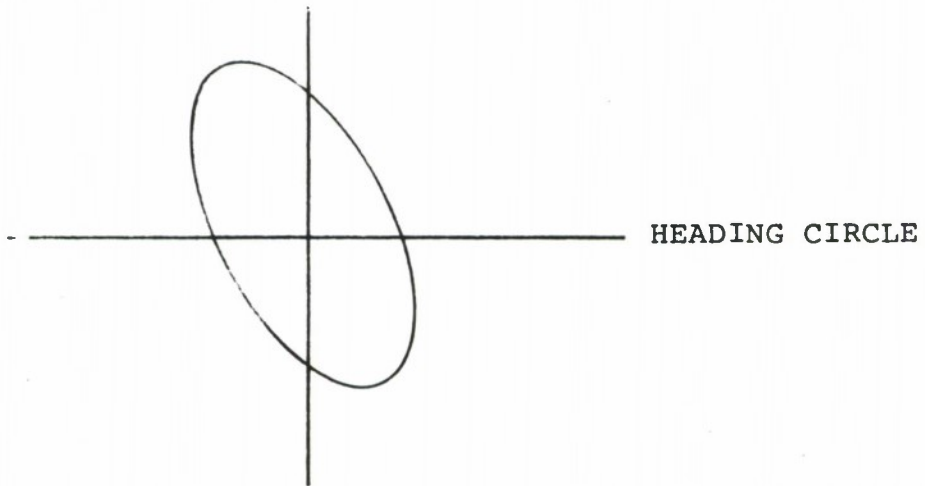

HEADING CIRCLE

Heading circle is elongated in direction of disturbance in the N/S sense, but in the opposite direction in E/W. (mirror image)

FIGURE 2-13 ASYMMETRICAL SOFT IRON

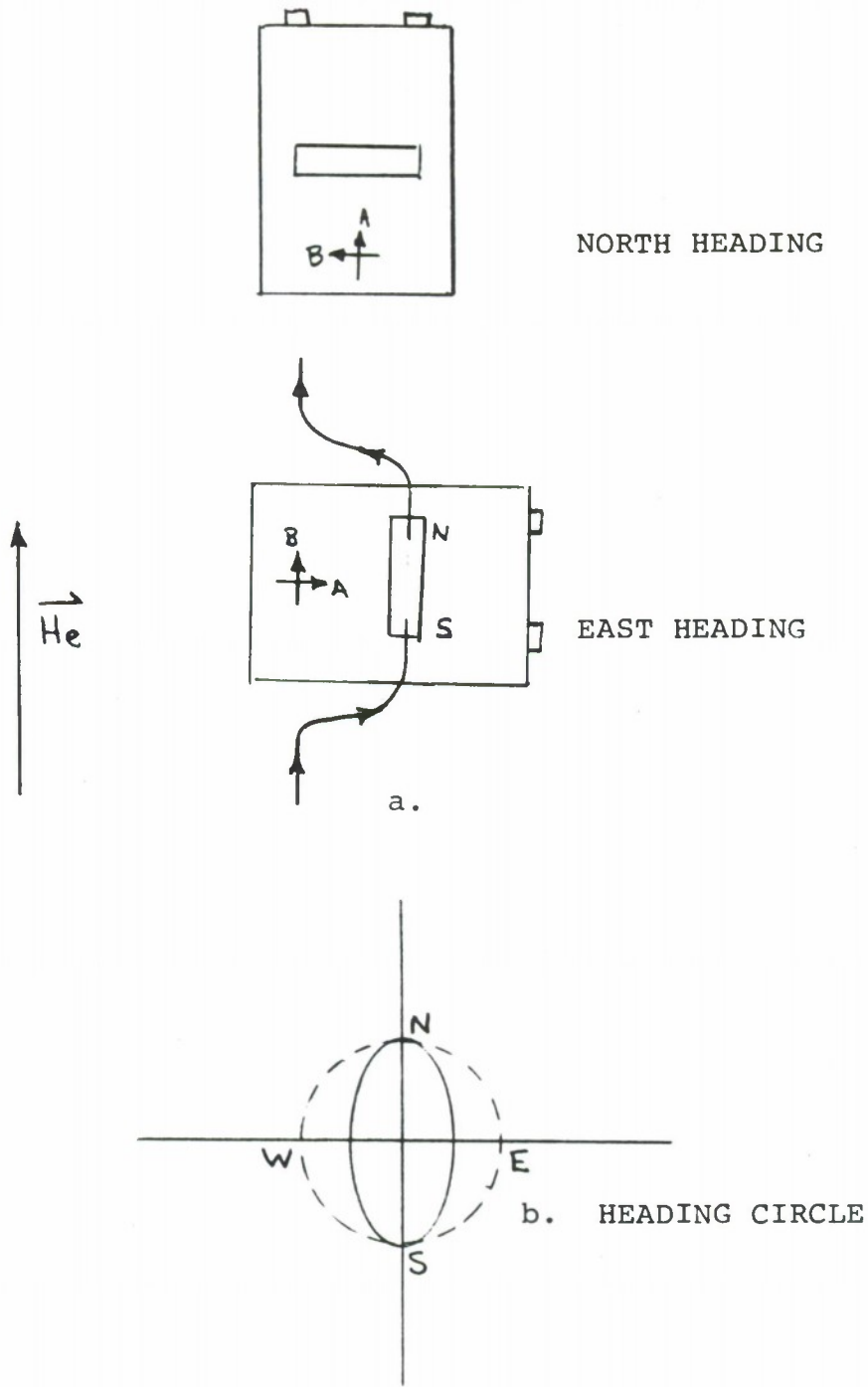

FIGURE 2-14 LATERAL SYMMETRICAL SOFT IRON DISTURBANCE



2.2 PROPOSED SOLUTION

Two basic approaches to the problem of automatic compensation of vehicle disturbances were studied during this contract. The first effort, described in detail in the proposal and the Phase I report for this contract, consisted of using dual sensors to measure the gradient of a disturbance. This gradient data can be extrapolated and, assuming that any disturbance would have a field that was asymptotically approaching the earth's field, sufficient data is available to determine the magnitude of the disturbance. Unfortunately the presence of multiple disturbances of different magnitudes and at different distances upsets the asymptotic condition when data is taken close to the vehicle. Because of this, the dual-sensor gradiometer approach had to be abandoned.

The second approach to the problem involved measuring the disturbance by comparing the outputs of two orthogonal sensors while varying the heading of the vehicle. A novel procedure was evolved (Patent Disclosure #AA-72-252) in which any disturbance present was automatically measured and calibrated out simply by driving the vehicle slowly in a small circle. The technique of accomplishing this is most easily understood by considering the analysis of Section 2.1.

From the previous section, it was seen that the problem of disturbance compensation can be considered one of calibrating out horizontal permanent magnet (PM) disturbances and their equivalent, and soft-iron disturbances. Vertical PM disturbances and vertical soft-iron can be equated to a horizontal PM disturbance with the dominant pole closest to the compass. All other horizontal PM disturbances can be reduced to an equivalent case of one longitudinal and one lateral disturbance. Horizontal soft-iron tends to elongate the heading circle described in the previous section into an ellipse, and asymmetrical soft-iron can rotate the plot, or even rotate just one axis of it.

Data taken on two Armored Personnel Carriers (APC's) during the study phase of this contract indicated that, the principal APC disturbance was of a lateral PM type, probably associated with the torsion bars of the vehicle. As was seen in Section 2, a disturbance of this type tends to shift the heading circle center a distance equal to the relative magnitude of the disturbance in the direction of the field in the N/S and in the opposite direction in the E/W. A general case is shown in Figure 2-15. The general equations for this circle in terms of the variable outputs of the two sensors A and B are

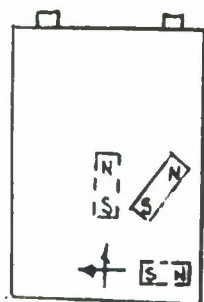

PM DISTURBANCE AND
ORTHOGONAL EQUIVALENTS

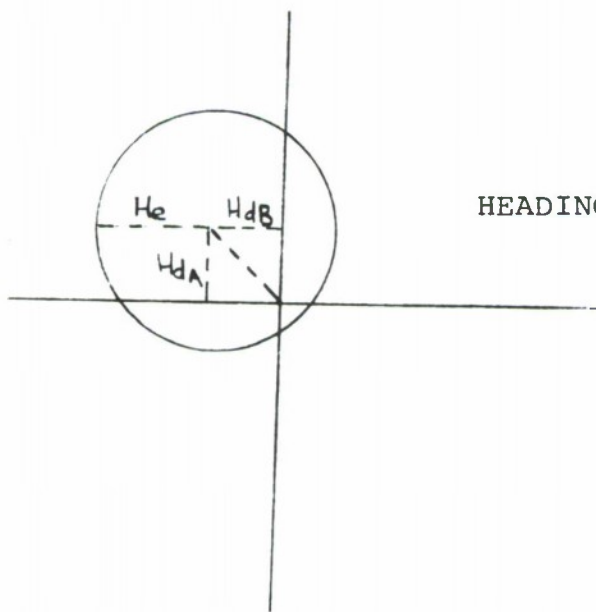

HEADING CIRCLE

FIGURE 2-15 GENERAL PM DISTURBANCE



$$A = H_e \sin \theta + H_{d_A} \quad (2.2.1)$$

$$B = H_e \cos \theta + H_{d_B} \quad (2.2.2)$$

Each sensor goes through two discrete separate nulls. If the voltage of each sensor is measured and stored as the other sensor goes through a null we have, with A nulled:

$$0 = H_e \sin \theta + H_{d_A} \quad (2.2.3)$$

or

$$\sin \theta = -\frac{H_{d_A}}{H_e} \quad (2.2.4)$$

$$\cos \theta = \sqrt{1 - \sin^2 \theta} = \sqrt{\frac{H_e^2 - H_{d_A}^2}{H_e^2}} \quad (2.2.5)$$

Substituting this in (2.2.2)

$$B = H_e \sqrt{\frac{H_e^2 - H_{d_A}^2}{H_e^2}} + H_{d_B} \quad (2.2.6)$$

$$B = H_{d_B} \pm \sqrt{H_e^2 - H_{d_A}^2} \quad (2.2.7)$$

B will have two values when A is nulled

equal to

$$B_1 = H_{d_B} + \sqrt{H_e^2 - H_{d_A}^2} \quad (2.2.8)$$

and

$$B_2 = H_{d_B} - \sqrt{H_e^2 - H_{d_A}^2} \quad (2.2.9)$$

If these values are added the result is

$$B_1 + B_2 = 2 H_{d_B} \quad (2.2.10)$$



or

$$H_{d_b} = \frac{B_1 + B_2}{2} \quad (2.2.11)$$

Thus the magnitude of the equivalent disturbance in the B sensor is equal to the average of the two values of the B sensor when A is nulled. Similarly the equivalent disturbance in the A sensor can be shown to be the average of the two values in the A sensor when B is nulled.

All that is necessary, then, to measure a PM disturbance less than the earth's field is to measure and store the sensor voltages when nulls occur and then average the correct pairs (E/W and N/S). This is what the LVN accomplishes when the APC is driven in a calibration circle.

Once the components of a PM disturbance are measured, it is a simple matter to create a counter disturbance to cancel it. In the LVN this is done by means of a feedback current in each sense coil that creates a magnetic field equal and opposite to the disturbance. In this manner the center of the heading circle is brought back to the origin making the headings correct.

This type of PM correction was sufficient to enable the LVN to operate with an accuracy of within 2.5% of the distance travelled. No significant amounts of soft-iron were measured on the APC's when operating with the heading sensor flush with the top rear of the vehicle.

For the additional out-of-scope measurements on the jeep and tank, however, correction of the PM disturbances present was not sufficient and there was an indication of significant soft-iron effects. Although beyond the scope of this contract and thus not presently incorporated in the LVN, the correction of soft-iron effects electronically could be accomplished on the LVN. It has been shown in Section 2 of this report that for symmetrical soft-iron disturbances, the heading circles become elliptical. To the extent that the axes of the ellipse lie in the cardinal directions, the anomaly can be adjusted out by varying the relative gains of the two orthogonal sensors. Thus, if the disturbance is symmetrical longitudinal horizontal soft-iron, the heading circle will be elliptical with a major axis in the north/south direction. If the gain of the sensor along the length of the vehicle is reduced appropriately (sensor A) the elliptical unbalance will be corrected and the heading errors removed. This suggests a simple technique for soft-iron correction in the LVN since the relative gains of the LVN flux gate sensors are easily varied.



In fact, by incorporating maximum and minimum detectors into the LVN in place of the present null detectors, the soft-iron calibration could conceivably be accomplished automatically during the same time that the PM disturbances are compensated. This soft-iron technique, when added to the present capability of automatically correcting PM disturbances, would compensate for most disturbances found on vehicles.



3.0 SYSTEM OPERATION

The Land Vehicle Navigator (LVN) breadboard developed on this contract is a self contained dead-reckoning vehicle navigation system that uses an electronic flux gate compass and the vehicle odometer data to automatically compute and display the position of the vehicle. The system position read-out, which is continuously and automatically updated, is given in terms of standard military 8 digit coordinates. The LVN also incorporates a heading indicator which continuously reads out the vehicle heading.

The LVN was designed for operation on the M113 Armored Personnel Carrier (APC). The system consists of a compass, a processor, a display and control unit, and a heading indicator. (See Figure 1). The compass mounts flush with the outside rear of the APC (Figure 2) and is connected by means of a cable to the processor which is carried inside the vehicle. Also connected to the processor is the unit and a heading indicator.

The display and control unit (Figure 3-1) reads out the vehicle's position in terms of a pair of standard military 4 digit coordinates. The first four digits are an Easting and the second four, a Northing, i.e. the first four digits indicate the distance in tens of meters to the east of a designated UTM (Universal Transverse Mercator) grid reference, and the second four indicate the distance to the North of this reference.

The heading indicator (Figure 3-2) reads the instantaneous vehicle heading in degrees to the nearest 2 degrees. This unit is intended as a guide for the APC driver and includes a cable that can be extended into the driver's compartment.

As a vehicle navigation system the LVN is unique in that it incorporates the capability to automatically compensate for magnetic disturbances on the vehicle. This is accomplished by driving the vehicle slowly in a small circle in a special calibration mode. As the vehicle turns through 360°, the LVN automatically assesses which part of the magnetic field is caused by vehicle disturbances and compensates for them. Once this is accomplished the vehicle position is then always automatically displayed on the coordinate display unit because the compass now measures the corrected heading while an input from the vehicle odometer supplies distance information. These are then combined in the processor to give the real-time position. The position display is automatically updated whenever it changes.

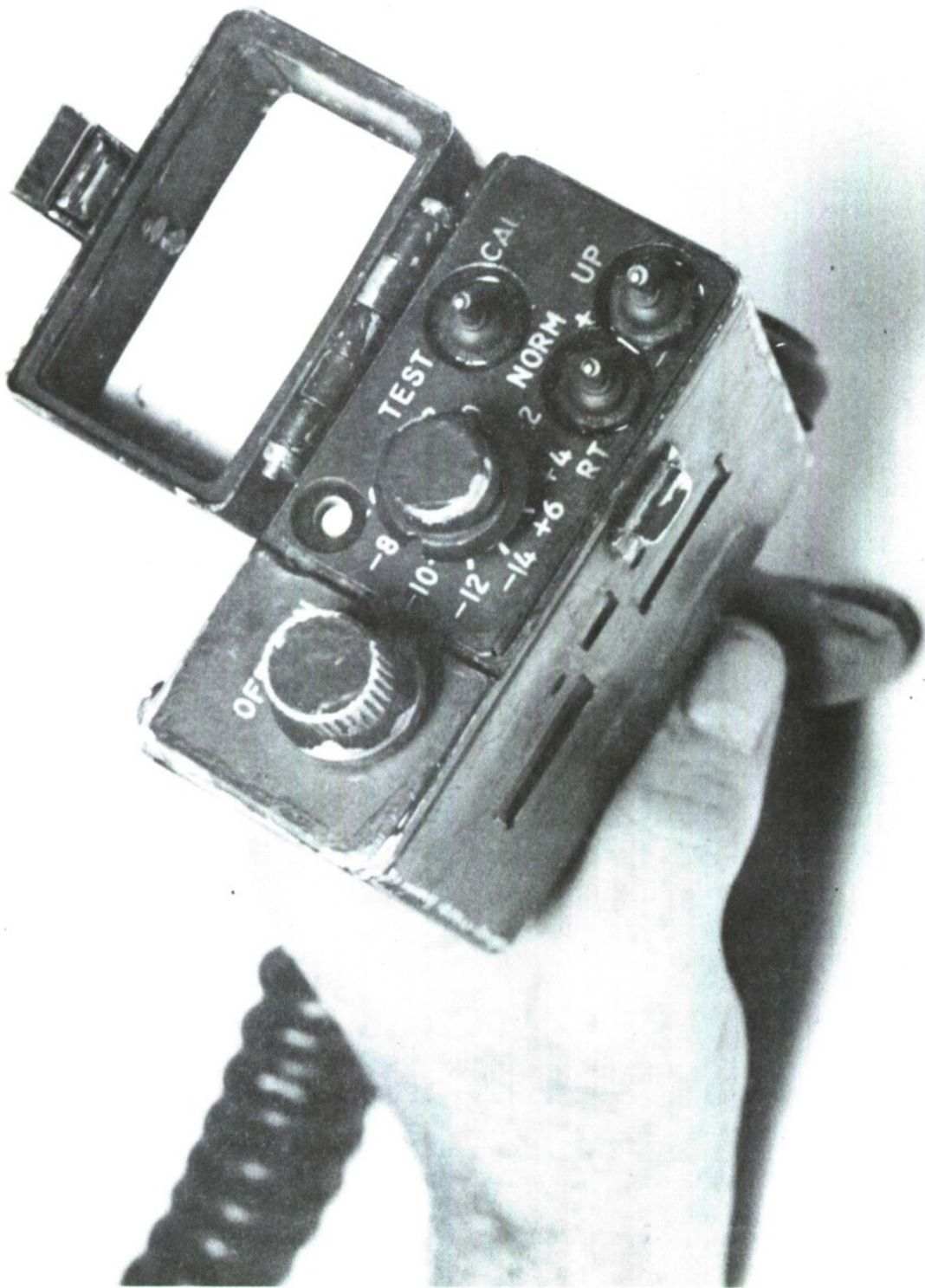

FIGURE 3-1 DISPLAY AND CONTROL UNIT

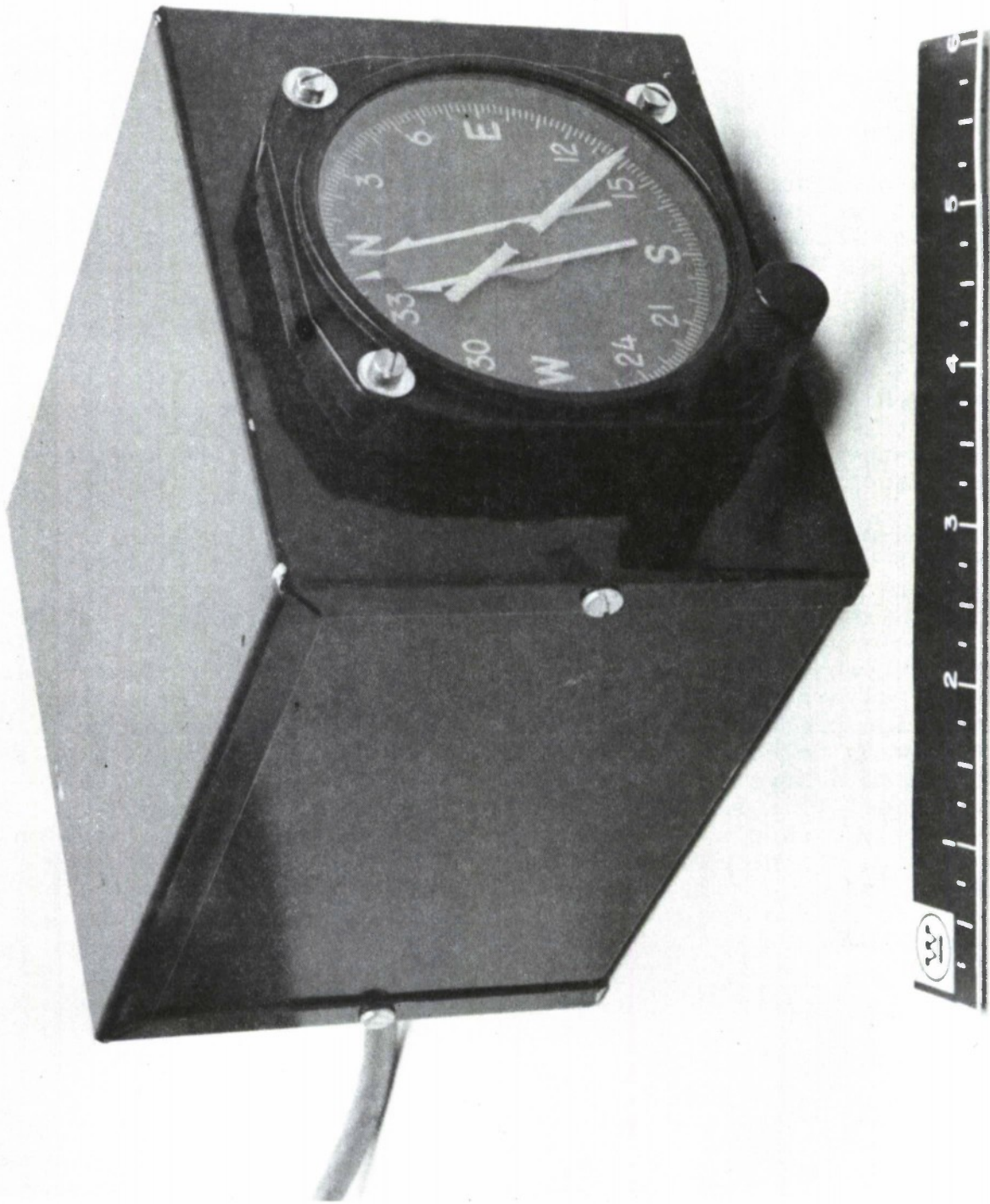

FIGURE 3-2 HEADING INDICATOR



The LVN calibration need only be performed one time unless the magnetic characteristics of the vehicle are altered in some way. Thus, the calibration is maintained even if the system power is turned off, the processor temporarily removed, etc.

The procedure for calibration is as follows. The track commander or navigator turns the system on and sets the mode switch to CALIBRATE. As he does so, four indicator lights labelled, N, E, S, and W come on. The driver of the vehicle then drives the vehicle slowly in a small circle of about 80 feet in diameter. No special requirements are necessary other than the calibration area be relatively smooth and level and that the vehicle speed be slow (approximately 1 MPH). As the vehicle turns, the N, E, S, W lights will go out one by one. After the last light is out, the track commander simply switches the system out of the calibrate mode and the calibration is accomplished.

This calibration technique is designed to be a field-expedient procedure. No additional equipment (such as gyroscopes or compasses) is needed and it is also not necessary to know direction. The calibration can be done in any location; it is not necessary to establish a depot calibration set up. Since the vehicles often carry a considerable amount of magnetic material as a normal load, the importance of a field-expedient calibration procedure can be easily seen. When the vehicle is loaded—when soldiers with equipment tow chains, jacks, shovels, axes, guns, ammunition, barbed wire, etc., are loaded aboard—all of these things become a part of the vehicle magnetic signature and should be calibrated out. If, during the mission, the load is changed substantially, it may be crucial to the mission and to a safe return, that the vehicle be quickly recalibrated in the field. This is the philosophy behind the LVN operation procedure.



4.0 SYSTEM DESIGN

The Land Vehicle Navigator consists of a compass, a processor, a display and control unit, and a heading indicator. Each of these subsystems is described in detail in this section.

4.1 COMPASS

The LVN compass consists of a compass sensor and the associated processing circuitry contained on one card integral to the compass package. Also associated with the compass are the two processing cards located in the system processor.

The compass sensor is a flux gate type similar to that used on the AN/PSN-7, being suspended on a pendulum in a damping fluid. Two orthogonal sense windings sense the magnetic field magnitude parallel and perpendicular to the vehicle. The compass output is a sine wave whose amplitude is proportional to the strength of the ambient field and whose phase is indicative of the vehicle's orientation in the field.

The electrical operation of the compass is illustrated by the block diagram of Figure 4-1. The two outputs of the flux gate sensor are two in-phase 10 KHz sine waves whose amplitudes vary in proportion to the earth's magnetic field strength times the cosine of angle between the earth's field and each sense coil. Because of the coil orthogonality, one output varies as the sine, and the other, as the cosine of the heading angle. These two outputs are electrically shifted in phase to be 90° out-of-phase with each other and then added. The resultant is a 10 KHz sine wave whose amplitude varies only with the earth's magnetic field strength and whose phase varies with the heading angle. This signal is passed through a variable phase-shift network whose setting corresponds to the magnetic declination in the area in which the LVN is being used. This declination phase shift rotates the heading information electrically so that the final readout will be referenced to grid or true north rather than magnetic north. The signal is then amplified with an automatic gain control (AGC) so as to eliminate the amplitude variations and normalize the output for any given earth's field strength. The signal is then filtered to remove harmonics. The output of the filter is used to derive the AGC controlling voltage. The filtered output is then phase detected in two phase detectors whose references are shifted 90° with each other so as to resolve the final outputs into two orthogonal components, east and north. These outputs are then DC values whose magnitudes represent the sine and cosine of the true heading angle.

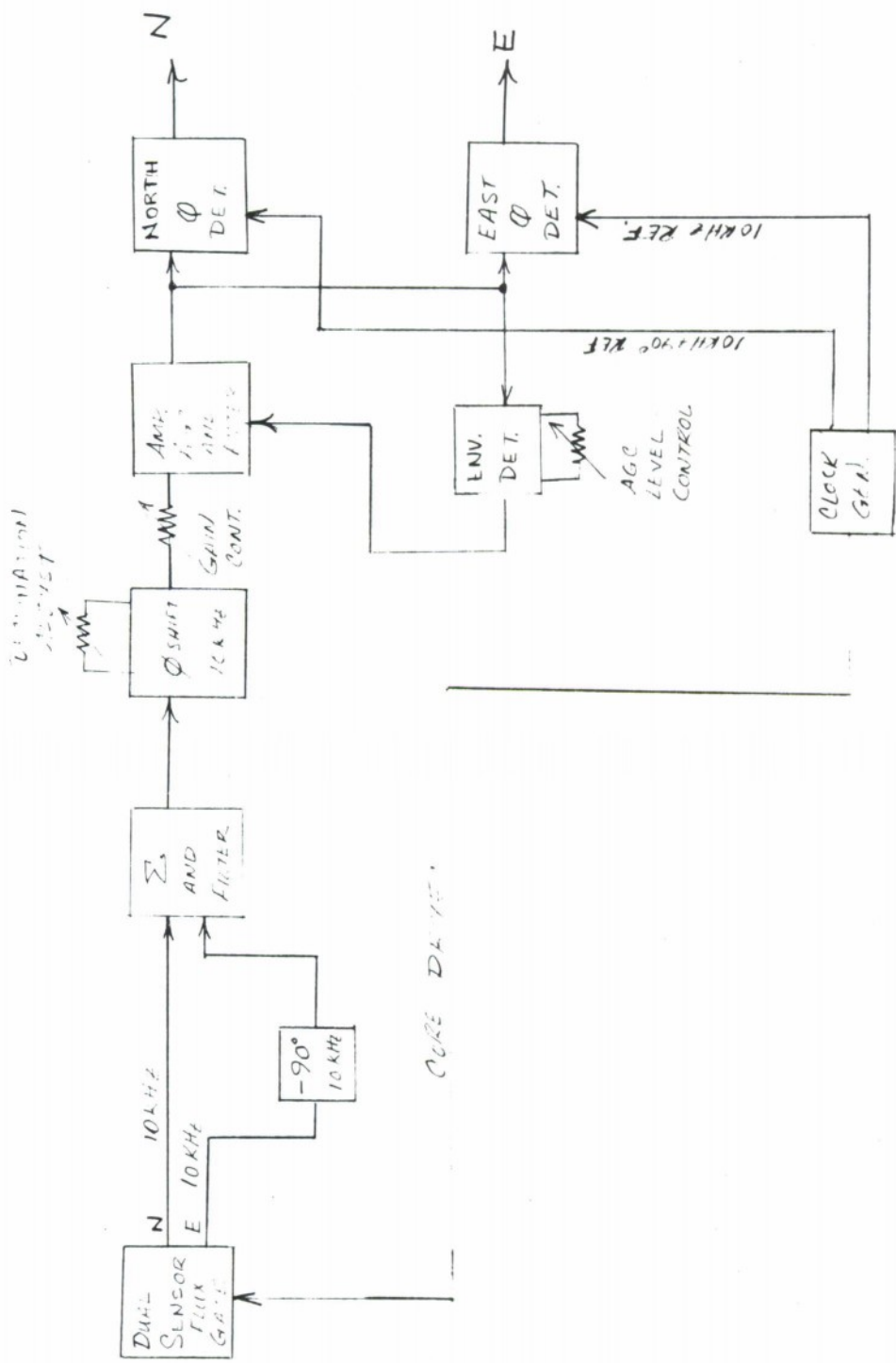

FIGURE 4-1 BLOCK DIAGRAM OF COMPASS AND PROCESSOR



The clock generator derives the necessary reference signals for the phase detectors and the core driver for the flux gate sensor.

4.1.1 Detailed Description

The sensor element consists of orthogonal flux gate sense windings mounted on a pendulum, as shown in the sketch in Figure 4-2, so that the sense windings are free to seek horizontal under any tilt conditions. The pendulum is suspended in a damping fluid to minimize oscillations due to vehicle vibrations. Photographs of the sensor element and the compass are shown in Figures 4-3 and 4-4.

As the core of the flux gate is driven into saturation a voltage spike is induced in each sense winding proportional to the ambient magnetic field in direction of that winding. The sense windings are oriented so that one is parallel and one is perpendicular to the vehicle. When resonated the output of the sense windings are sine waves (e_1 and e_2) whose amplitudes (a and b) are proportional to the ambient field components parallel and perpendicular to the vehicle heading.

$$e_1 = a \sin Wt \quad (4.1.1)$$

$$e_2 = b \sin Wt \quad (4.1.2)$$

The output of the coil perpendicular the vehicle is shifted 90° (Figure 4-5) and added to that of coil parallel to the vehicle. The resulting signal (e_o) is a sine wave whose amplitude is proportional to the ambient field magnitude and whose phase is indicative of the vehicle's heading relative to this field.

$$e_o = a \sin Wt + b \sin (Wt - 90^\circ) \quad (4.1.3)$$

or

$$e_o = a \sin Wt - b \cos (Wt)$$

which can be expressed as

$$e_o = \sqrt{a^2 + b^2} \sin (Wt - \arctan b/a) \quad (4.1.4)$$

If the ambient field has been compensated for magnetic disturbances the output signal phase is indicative of the vehicle heading relative to magnetic north.

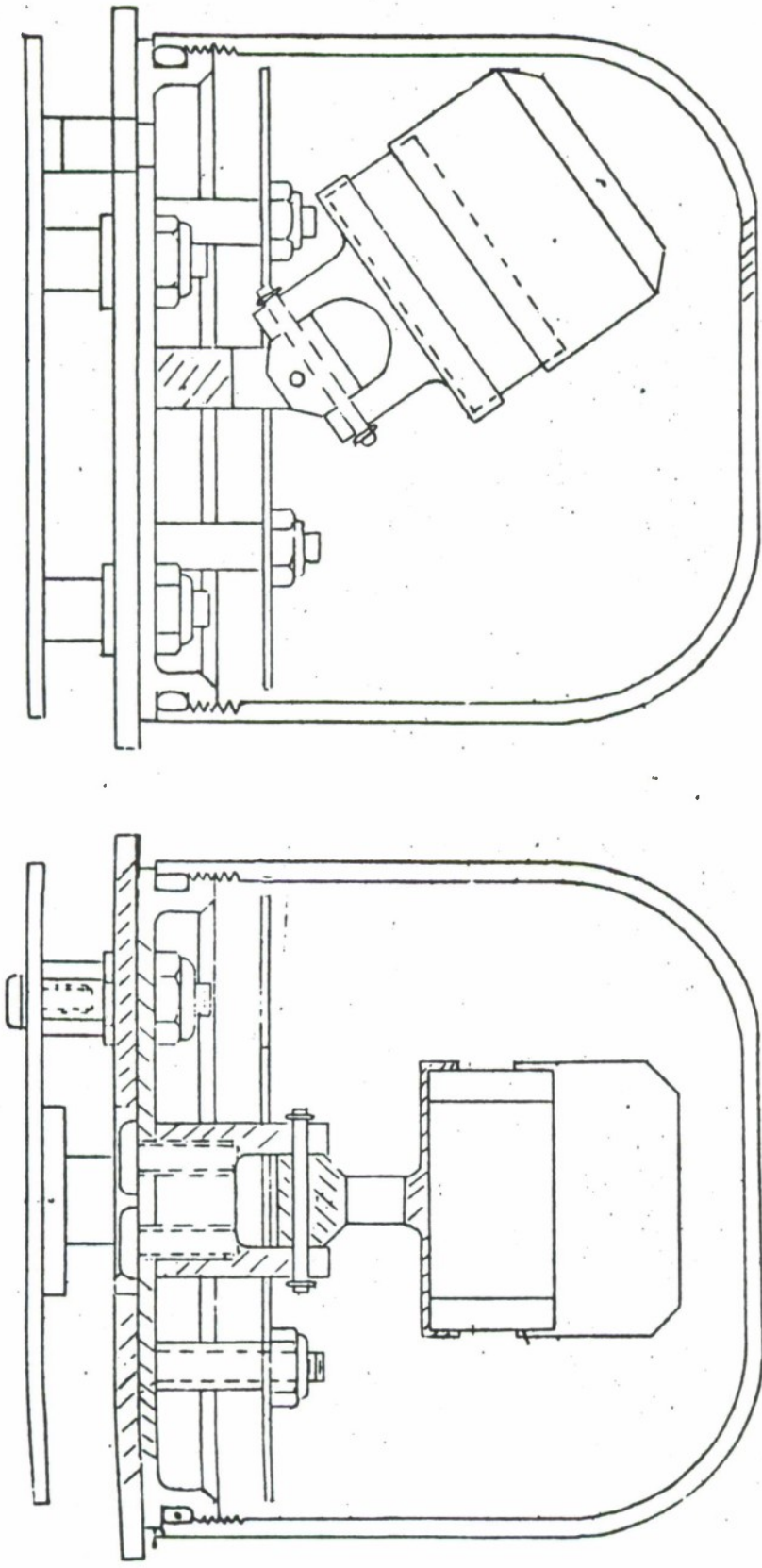

FIGURE 4-2 COMPASS DRAWING

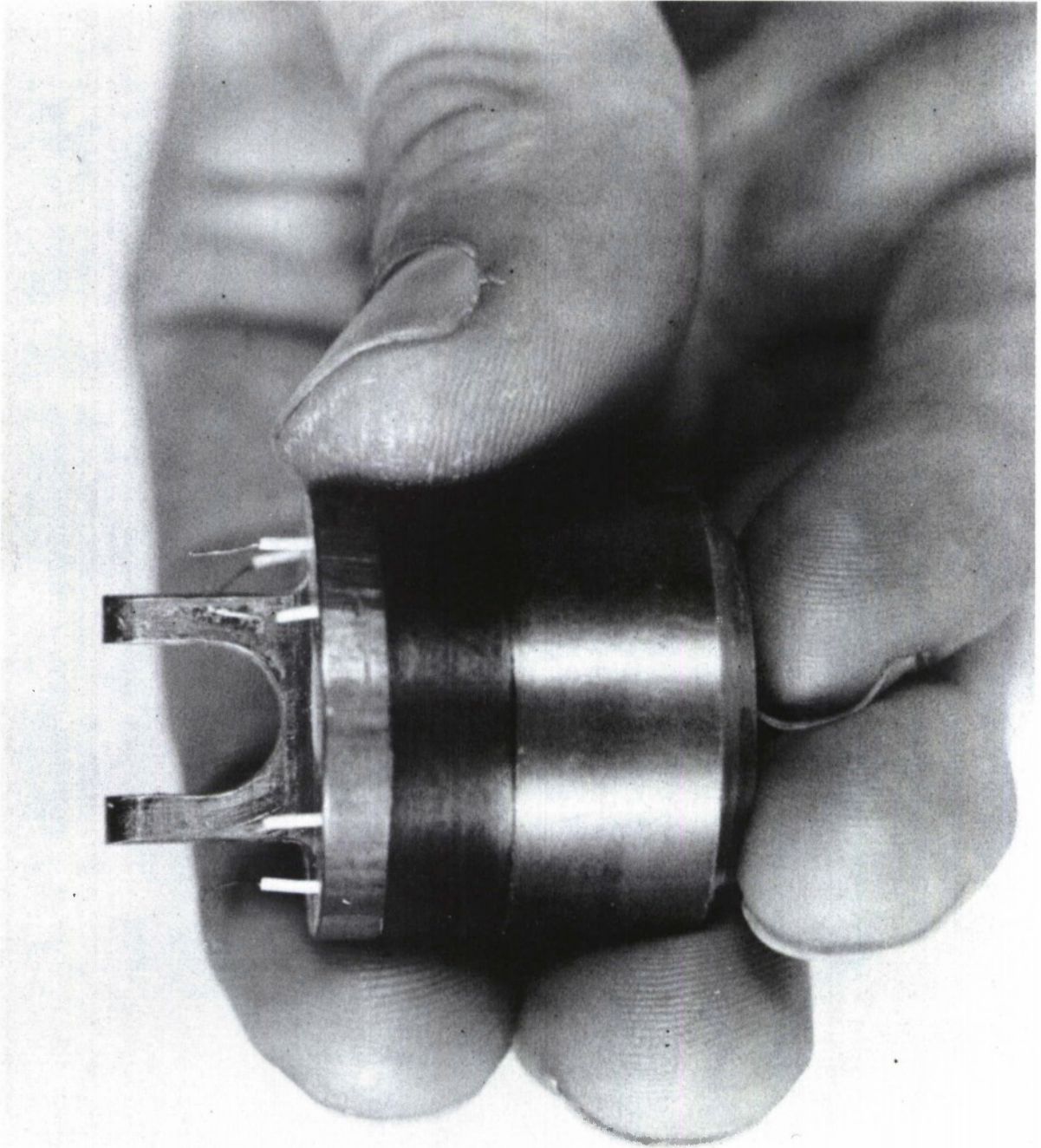

FIGURE 4-3 SENSOR ELEMENT

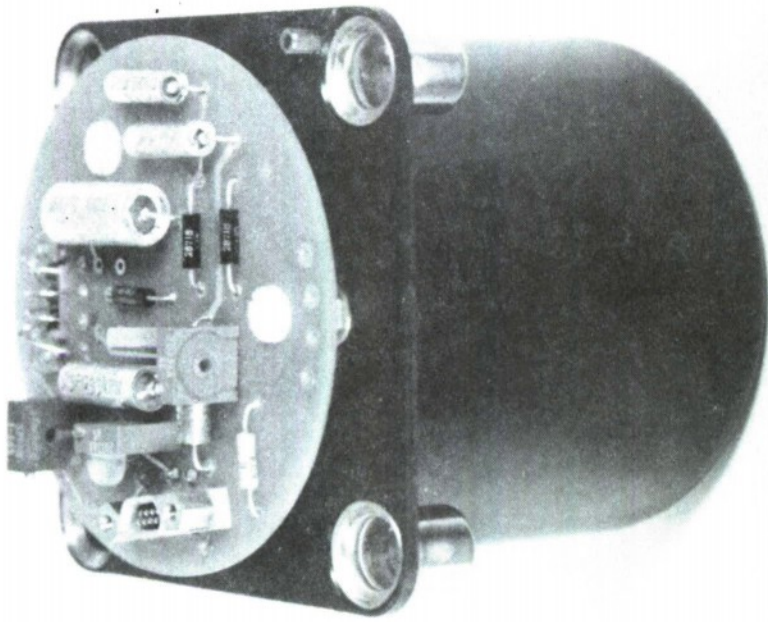

FIGURE 4-4 IVN COMPASS



4.1.2 Sensor Card

The sensor PC card is an integral part of the compass, being mounted on top of the sensor itself (Figure 4-4). The function of this card is to equalize the outputs from the two sense windings, provide the desired 90° phase shift between them, and add them together.

The schematic of this card is shown in figure 4-5. The following explanation makes reference to that schematic. C3 provides the tuning for the first sense winding, and C4, for the second. R2 adjusts the amplitude of Sense 2 to equal that of Sense 1. C₆ is the input to a differentiator circuit (the remainder of which is on the compass processor card) and shifts the phase of the signal in sense winding #1 90°. The outputs are summed together at Pin 5 which goes into an OP AMP on the compass processor board.

4.2 PROCESSOR

The LVN Processor consists of eleven circuit boards, i.e., the compass processor, the clock and core drive, the resolver, the north channel, the east channel, the distance increment and control card, the calibrate card, the power supply, the regulator, and the miscellaneous control and filter board. Each of these boards is described in detail in this section.

4.2.1 Compass Processor

Figure 4-6 shows the compass processor schematic. This card also contains the AGC amplifier that normalizes the summed sense voltages to make the amplitude constant, independent of the earth's field intensity. Also included are two declination circuits providing a variable phase shift to allow the headings to be referenced to true north or grid north rather than magnetic north. A filter follows the declination circuits to remove any harmonics of the desired 10 KHz output. The output of this filter derives the controlling voltage for the AGC that normalizes the summed sense voltages. Finally, the board contains two phase detectors with quadrature references to derive the final compass outputs. Each of these portions of the compass processor is discussed in detail in the following referring to the figure schematic.

The inputs from the compass are summed into Z1, the output of which is a sine wave whose amplitude is proportional to the field strength and whose phase is indicative of the heading. R₁, R₂, R₃, R₄, C₁, C₂, and C₃ form a bridged tee

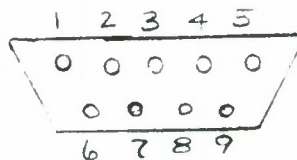
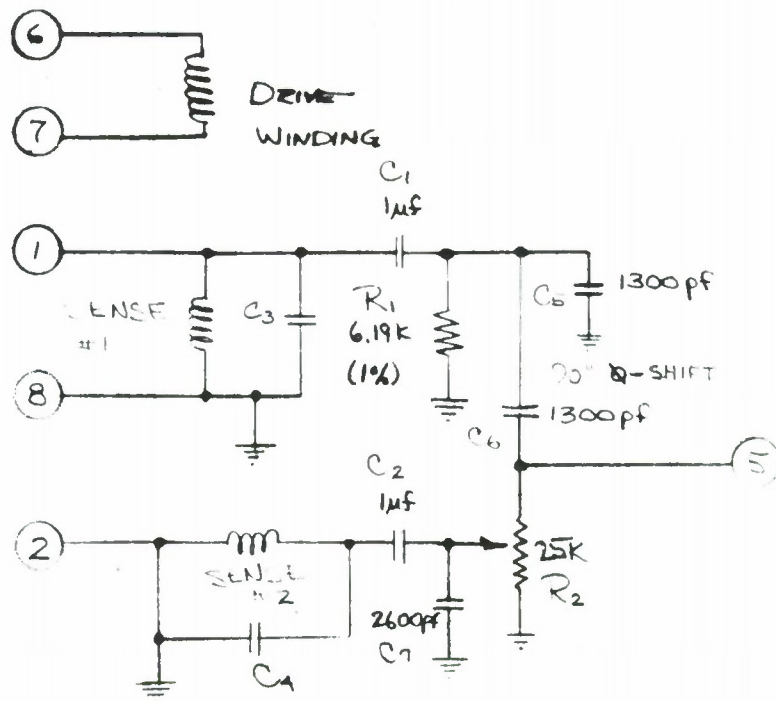

FIGURE 4-5 COMPASS SCHEMATIC

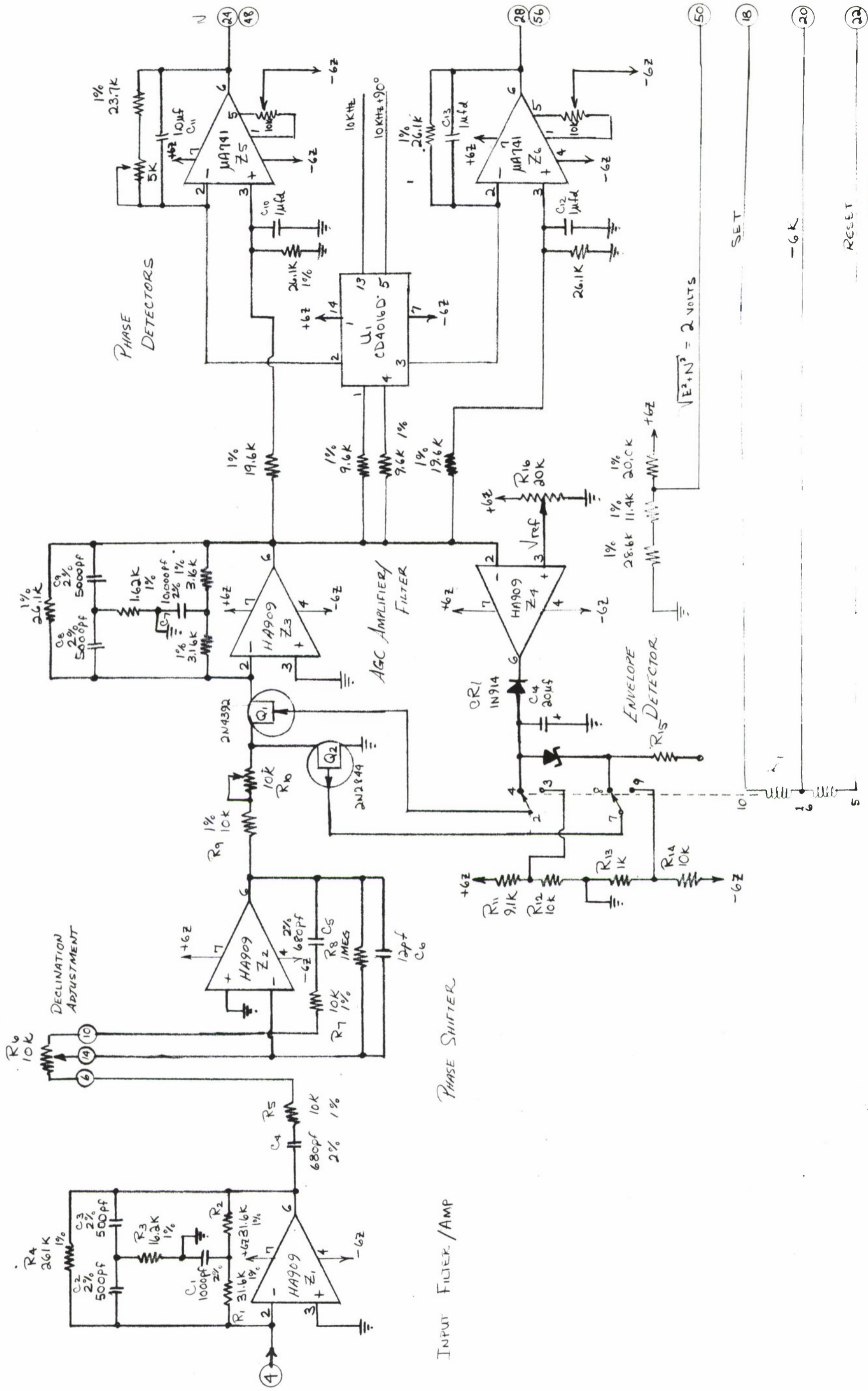

FIGURE 4-6 COMPASS PROCESSOR

TECHNICAL LIBRARY
 BLDG. 305
 ABERDEEN PROVING GROUND, MD.
 STEAP-TL



feedback network making the Z1 stage both a summing amplifier and an active filter whose center frequency is at 10 KHz. The declination control is used by the system operator to initially zero the system declination and to set in the local magnetic declination in order that system output can be referenced to true north. The declination circuit consists of OP AMP Z₂ and its associated circuitry. The series combination of C₄ and C₅ and part of R₆ form the input network to the inverting OP AMP and the rest of R₆, C₅, and R₇ form the feedback network. If the total resistance (R₅, R₆ and R₇) is made to approximately equal to the reactance of C₄ and C₅, large linear phase shifts can be obtained with only minimal changes in amplitude.

4.2.1.1 The AGC Amp/Filter

In resolving the heading into N and E components it is desirable to detect the phase angle of the compass output. It is therefore necessary to remove any amplitude variations in the signal. This is done using an Automatic Gain Control (AGC). Q₁ and Q₂ form the control elements of the AGC. The input signal is divided between Q₁ and Q₂. That portion of the input current flowing through Q₁ is amplified by Z₃ and is passed on to the phase detectors. The portion of the input current flowing through Q₂ is diverted to ground. The gain can be varied by varying the bias of the gates of Q₁ and Q₂. The output of Z₃ is compared to a reference voltage as set by R₁₆. If the output of Z₃ is greater than the reference signal the output of Z₄ will switch from positive to negative causing C₁₄ to change more negatively. The voltage on C₁₄ is used to bias the gates of Q₁ and Q₂ and vary the overall gain so that the peak output of Z₃ is held constant at the reference voltage.

The relay K₁ is used to disable the AGC. Under normal operation the relay is in the position shown and the AGC is controlling the output signal level. However, during the calibrate mode it is necessary to measure the amplitude of the ambient field. K₁ is switched to the alternate position during the compass calibration procedure and the amplifier (Z₃) is a fixed gain amplifier. The open loop gain is adjusted using R₁₀. The adjustment is overruled by the AGC when the system is not in the calibrate mode.

4.2.1.2 Phase Detectors

The output circuitry of the compass processor consists of two product phase detectors with quadrature references which resolve heading information into north and east components. Each phase detector is identical in operation. The East phase detector uses Z₅ to compare the signal with the switched signal.



The switched signal is gated using the FET switches in U1. If the signal is in phase with the 10 KHz clock the output of Z_1 is a maximum positive dc voltage. If the signal is 180° out of phase with the 10 KHz clock the output of Z_5 is a negative signal. If the signal is 90° out of phase with the 10 KHz clock the output of Z_5 is zero. The output of the East phase detector is equal to a constant times the sine of the heading angle: The constant is set by adjustment of the AGC level control (R_{16}) to equal 2 volts.

Thus the phase detector outputs are:

$$E = 2 \sin \theta$$

where θ is the heading angle counter clockwise from N.

The North phase detector compares the signal with the 10 KHz + 90° clock in the same manner, however, the 90° phase shift output gives a cosine relationship to heading.

$$N = 2 \cos \theta$$

The East and North heading components are then set to the resolver to be combined with the distance factor.

4.2.2 The Clock Generator and Core Drive

The clock generator circuitry is used to provide all reference and clocking signals used in the Processor. All timing signals are derived from a 80 KHz crystal controlled oscillator. The core drive circuitry is used to provide a stable 5 KHz current drive to the flux gate sensor. The schematic of these circuits are shown in Figure 4-7.

4.2.2.1 Clock Generator

The OP AMP Z_1 , the 80 KHz crystal, and their associated circuitry form an 80 KHz stable oscillator. The output of this oscillator is used to generate all reference frequencies used in the system. The 80 KHz clock is divided down by flip-flops FF1, FF2, and FF3 to 40 KHz, 20 KHz, and 10 KHz signals. The 10-KHz signal is clocked at FF-5, by the 20 KHz signal to obtain the 10 KHz + 90° signal. The 10 KHz and 10 KHz + 90° signals are then used as the references for the phase detectors. The 10 KHz signal is further divided to 5 KHz by FF-5. The 5 KHz signal is used to derive the core drive signal for the compass.

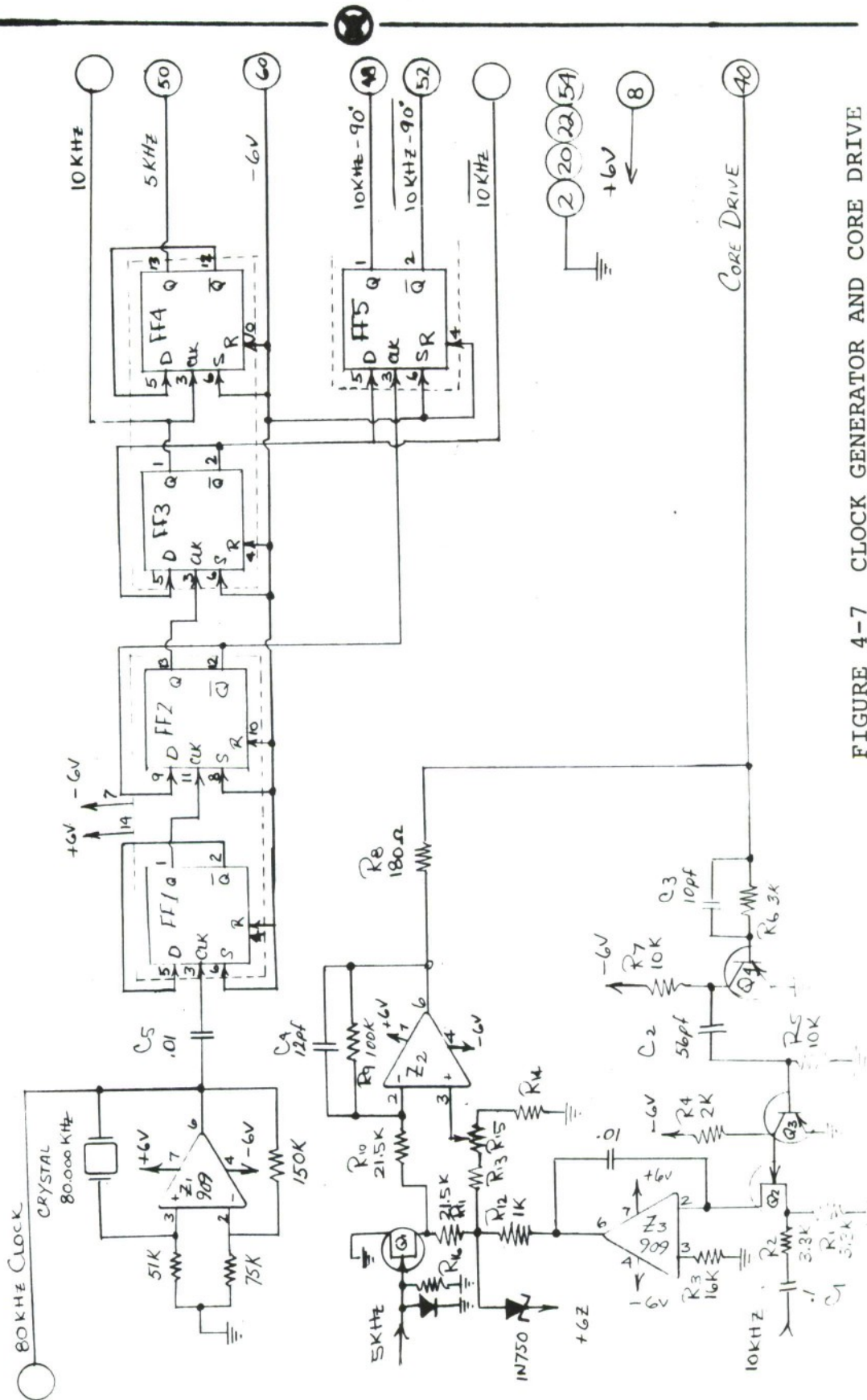

FIGURE 4-7 CLOCK GENERATOR AND CORE DRIVE



4.2.2.2 Core Drive

The function of this circuit is to regulate the amount of drive voltage applied to the compass sensor toroid coil so that the core always saturates at the mid-cycle point of the 5 KHz drive. To do this, the voltage across the core is compared to a 10 KHz reference signal. The loop is designed to increase the applied voltage if saturation is occurring too late, and to decrease it if saturation is too early. This will move the saturation point in the appropriate direction since the saturation time is directly proportional to the applied voltage-time product.

The core drive is obtained from Z2, which has as its input the basic 5 KHz square wave plus the controlling error voltage from Z3. The output of Z2 is a 5 KHz square wave the amplitude of which varies with the error voltage. The voltage across the core appears as in Figure 4-8. Q4 is on during the negative portion of the core drive cycle and switches off as the core saturates. This applies a negative edge to the differentiator C2 and R5 so that Q3 turns on and pulls its collector up to ground briefly. The gate voltage of Q2 is then a pulse that represents the time that the core just goes into negative saturation. Q2 will turn on to pass the 10 KHz square wave reference during this pulse. If the corresponding edge of the 10 KHz occurs during the center of the saturation pulse, no net DC will be passed by Q2 to the amplifier Z3, and no correction is applied to Z2. Should saturation be late, Z3 will see a net negative voltage applied to its inverting input. This will result in a net increase in the voltage being applied to the summing network into Z2 which will increase the voltage applied to the core. Should saturation be early, the opposite will occur. Q1 driven by a 5 KHz square wave, makes a synchronous inverter out of the OP AMP Z11. The configuration is inverting with Q1 off, and non-inverting with Q1 on. This allows R5 to adjust the start time for the positive saturation to be mid-cycle, also, by adjusting the balance between the positive and negative half cycles. Thus, the loop maintains the negative saturation time while the positive time is set by R15.

4.2.3 Resolver

The purpose of the resolver is to resolve the distance travelled into its North and East Components. The resolver used in the LVN is identical to the AN/PSN-5 resolver and the reader is referred to the AN/PSN-5 final report (Contract DAAD05-68-C-0428) if a highly detailed description of the resolver operation is desired.

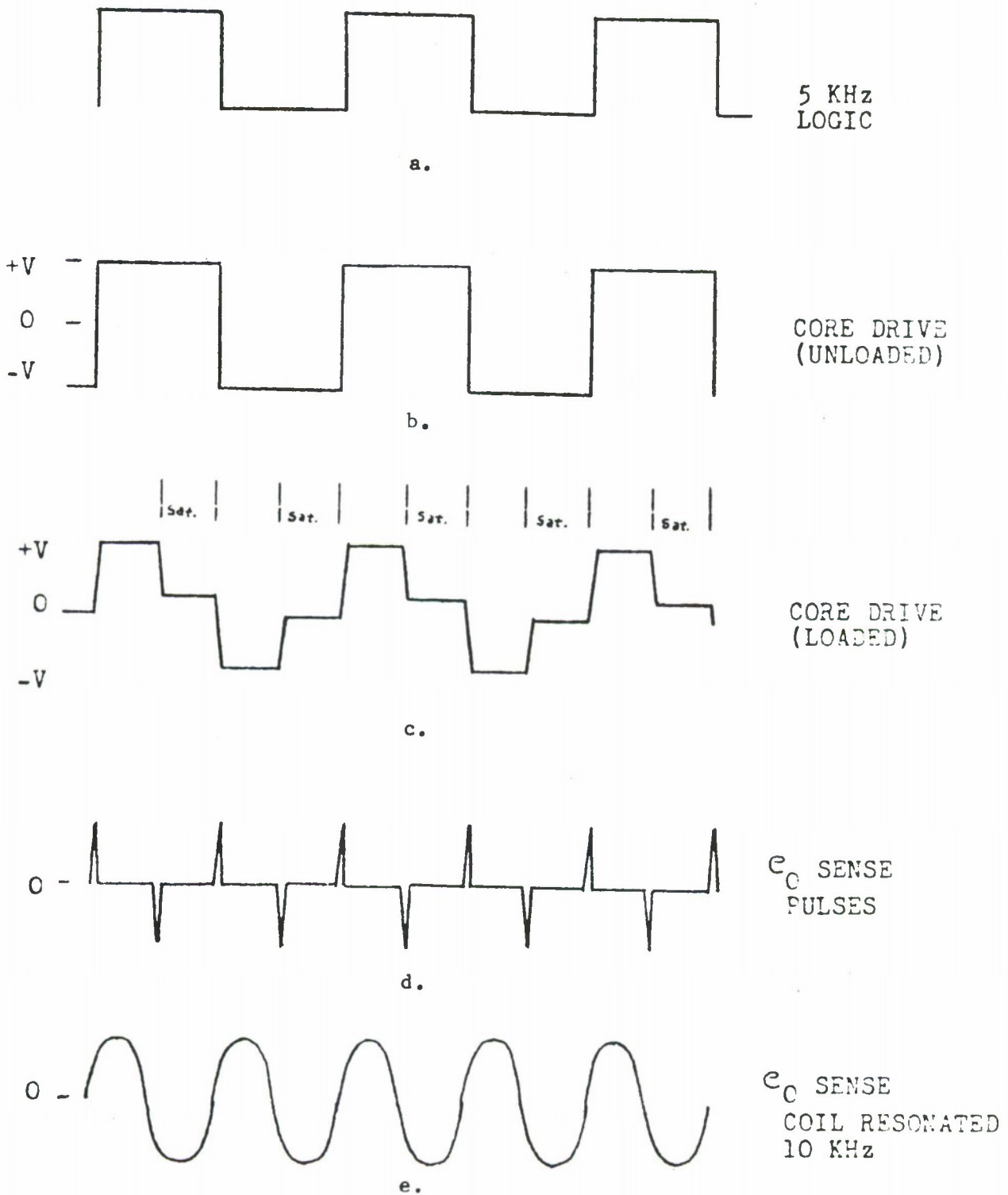

FIGURE 4-8 FLUX GATE WAVEFORM DIAGRAM



In order to perform its function 4 inputs to the resolver are required:

1. A compute pulse which indicates that a distance increment has been travelled. For the LVN a compute pulse is generated every four resolutions of the odometer cable.

2. A distance voltage which is inversely proportional to the distance travelled during the distance increment described above. For the LVN this voltage is proportional to the distance the vehicle travels for four odometer cable revolutions.

3. and 4. East and North heading components from the compass circuitry.

When a compute pulse is received by the resolver a ramp is started whose slope is inversely proportional to the distance voltage. (See Figures 4-9 and 4.10). In the North/South channel the North voltage is compared to the ramp voltage. If the north voltage is positive the north gate is opened during the time it takes for the ramp to change from zero to the north voltage. If the north voltage is negative (indicating a southerly heading) the North gate is opened for the time it takes the ramp to increase from the North voltage to zero. A zero crossing detector is used to determine if the North voltage is positive or negative (North or South). In either case the width of the North gate is inversely proportional to the slope of the ramp and therefore proportional to the distance travelled and also proportional to the magnitude of north voltage.

Similarly in the East/West channel the East voltage is compared to the range and a gate opened for a time proportional to the distance travelled and the magnitude of the East voltage. Again a zero crossing detector is used to determine if the East voltage is positive or negative (East or West).

A 44 KHz signal is applied to both the North and East gates. During the time the gates are opened the 44 KHz pulses are permitted to pass through to the counters on the Channel Logic cards. The number of pulses in each channel is proportional to the magnitude of North and East components of the distance travelled during the increment.

4.2.4 North and East Channel Cards

The processing circuitry makes direct use of AN/PSN-5 circuitry. It consists of a pulse adder circuit, divide-by-10 counters and a 5 bit ring counter for each channel (See Figure 4-11 for schematics).

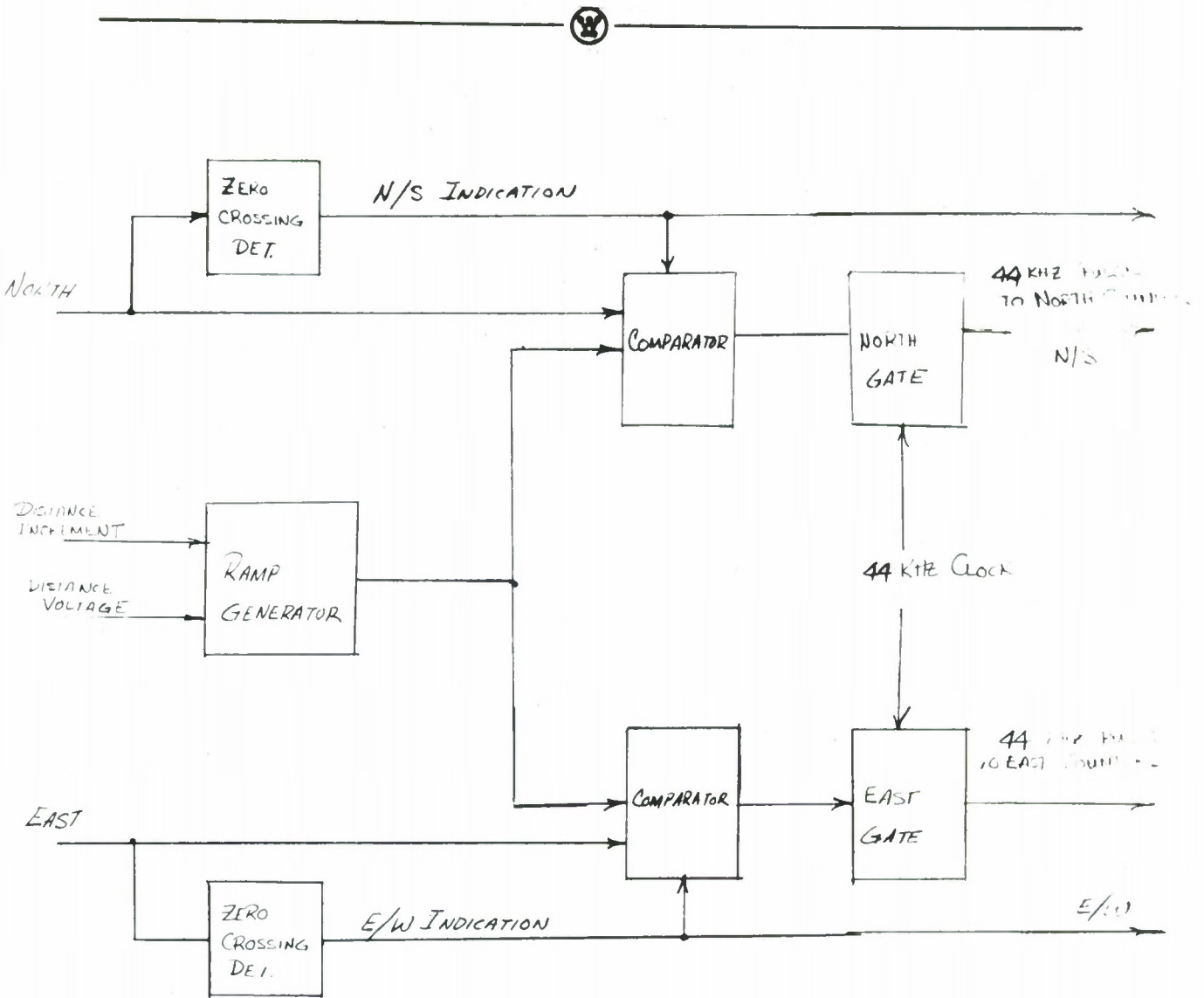

FIGURE 4-9 RESOLVER BLOCK DIAGRAM

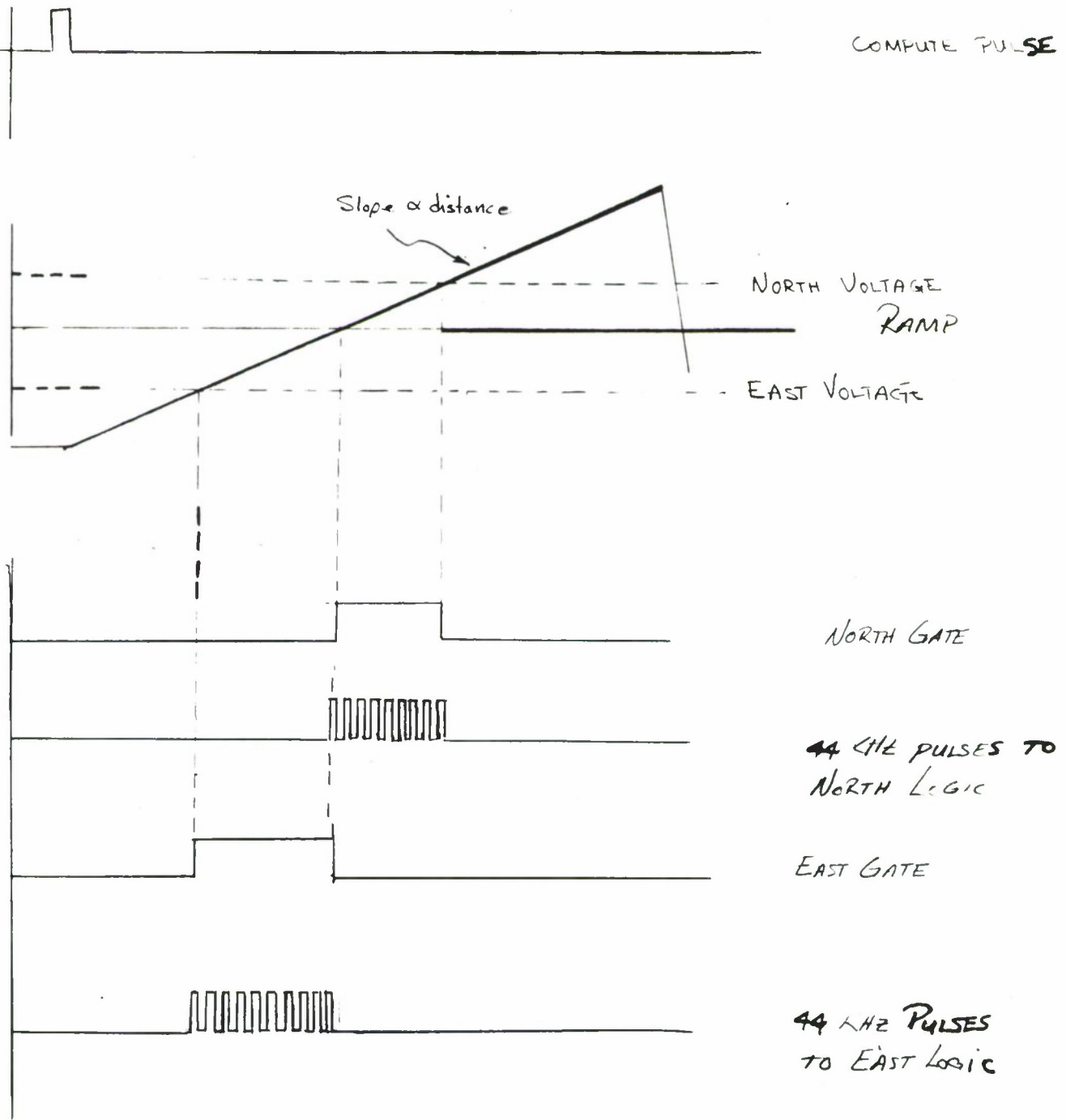

FIGURE 4-10 RESOLVER TIMING DIAGRAM



The pulse adder circuit adds pulses from the VCO to the 44 KHz clock. This circuit was used as part of a feed forward error correction loop in the AN/PSN-5 but this loop is not used in the LVN. The VCO is operated at a fixed 4 KHz frequency and the output of the pulse adder is a 44 KHz clock which (Refer to PSN-5 final report) is fed directly to the resolver E/W and N/S gates.

The frequency divider logic following the resolver outputs (N/S and E/W pulses) provides a divide-by-256 and a divide-by-10 followed by a five bit ring counter. The total division ratio used during normal operation is $256 \times 10 \times 5 = 12800$. Each pulse from the five bit ring counter is used to trigger a 4 bit ring counter for advancing the mechanical counter one digit or 10 meters, so that each pulse out of the resolver has a distance significance of

$$\frac{10 \text{ meters}}{12,800} = .00078125 \text{ meters/pulse}$$

The 5 bit ring counter is clocked by a 2-meter clock in the Normal Mode. These clocks are generated by the logical combination of the outputs of the 256 counter and the divide-by-10 counter (Refer to Figure 4.11). The direction lines from the resolver are retimed by the 2 meter clock, and depending on which direction line is enabled, the 5-bit ring counter will shift up or down. For example when the clock North direction line is enabled, the ring counter in the North channel shifts up and when the clocked South direction line is enabled, the same ring counter will shift down. The same is true for the two clocked lines in the East channel.

The output of the 5 bit ring counter is a 10 meter clock for the 4-bit ring counter. Every negative edge of the 10 meter clock causes a right or left shift of the 4-bit ring counter depending on whether the resolver is commanding an up or down shift. (The up and down shift commands are the same as those for the 5-bit ring counter.) The \bar{Q} output of each bit of the 4-bit ring counter drives one of the four motor drivers, so that the motor is stepped at the time a bit is set to "1".

There are two identical bi-directional coil drivers for each channel so it is necessary to discuss only one motor driver (refer to Figure 4-11 for schematic diagram of the motor drivers). Each time the output of A2 pin 23, \bar{Q} for bit 3, goes low, corresponding to bit 3 being set to "1", Q1 is turned off and Q2, Q3 and Q6 are turned on. Capacitor C4 and resistor R6 form a timing circuit which will maintain this condition for approximately 150 milliseconds. This is enough time for current in the stepping motor coil to rise to the steady-state value and

cause the motor armature to step by 90° . Q1 will remain off until its base voltage discharging to ground, reaches 0.7 volts above the -6 V supply, at which time it will turn on again, shunting the current through R7 to -6 V and thus turning off Q2, Q3 and Q6. A germanium diode CR1 shunted by 100 K is included to present a high impedance to the flip-flop when it is reset (\bar{Q} goes high). The time constant of (C4)(R6) will allow recovery to 0 volts across the diode by the time the "1" reaches the flip-flop again. The above description applies to all the coil drivers.

The coils are alternately pulsed one at a time as the "1" is shifted through the 4-bit ring counter by the 10/1 meter clock, with the current direction the reverse of what it was two motor steps earlier for rotation in a given direction.

The circuit associated with transistors Q17 and Q18 is used to inhibit the coil drivers at power turn on during TEST. At power turn on the POWER ON RESET goes positive turning on Q17 and Q18. Thus, the collector of Q18 goes to approximately -6 volts inhibiting all the coil drivers. When the POWER ON RESET is complete, Q17 and Q18 turn off enabling the coil drivers. This allows enough time for the logic to be properly set preventing erroneous counts at power turn on. During TEST, Q17 and Q18 are on inhibiting the coil drivers. TEST and POWER ON RESET are OR'ed at the emitter of Q17 by CR2 and CR3 shown in Figure 7.9.

4.2.5 Distance Increment and Control Card

4.2.5.1 Slew Control

The slew control is used by the operator to set in the starting coordinates and to update coordinates at reference points. The slewing system is controlled by two SPDT switches on the display and control unit; one controlling each channel.

The slewing clock schematic diagram is shown in Figure 4.12. It consists of an astable multivibrator the frequency of which varies as the analog input voltage to the base of Q5 and 6. This analog voltage is a ramp generated by the SLEW signal turning off Q7 allowing C9 to charge from +6 volts toward -6 volts. The slewing oscillator, therefore, begins at a very low frequency (< 1 Hz or one coordinate step per second) and gradually increases in frequency until it reaches a maximum frequency of about 50 KHz. In this manner it is possible to rapidly slew by several thousand while maintaining the resolution necessary to set the counters to any coordinate. The rate of the slew clock returns to 1 Hz as soon as the SLEW signal is terminated.

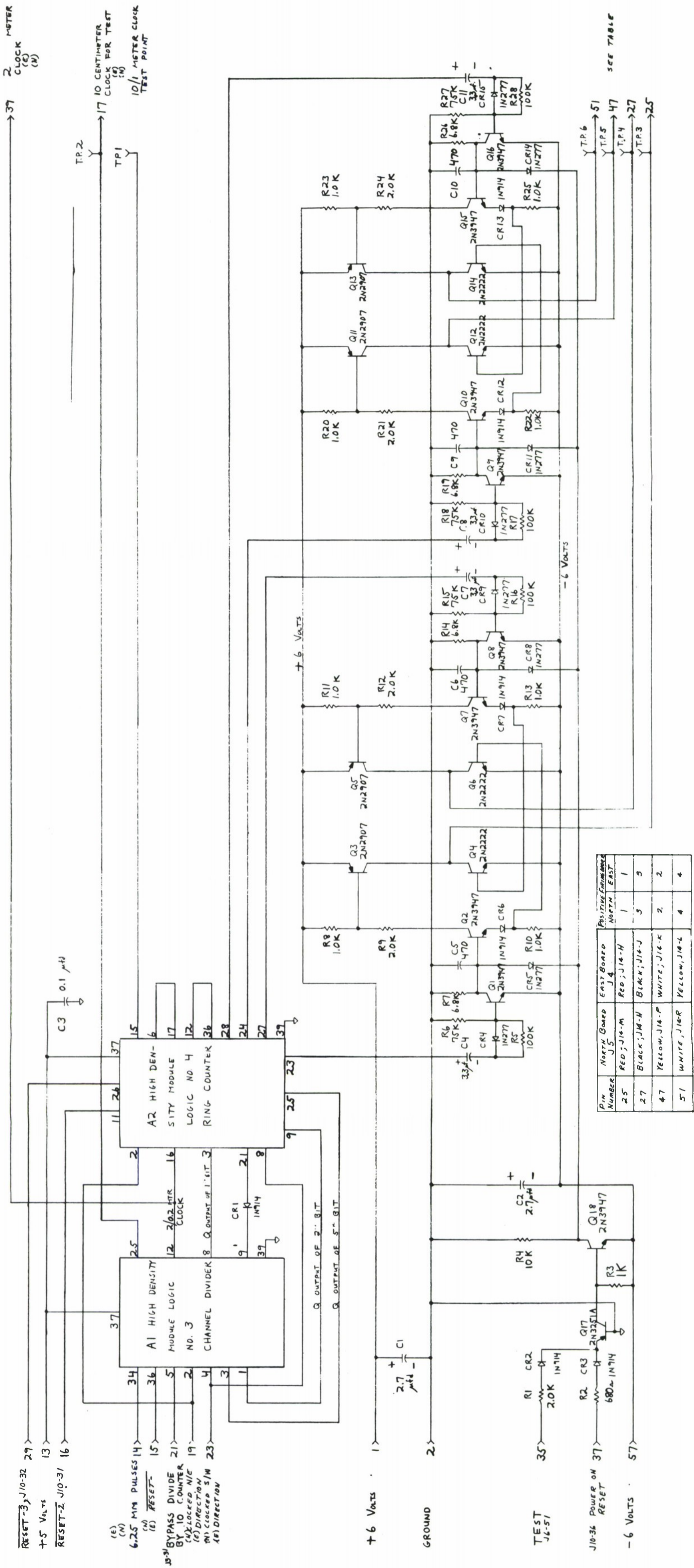
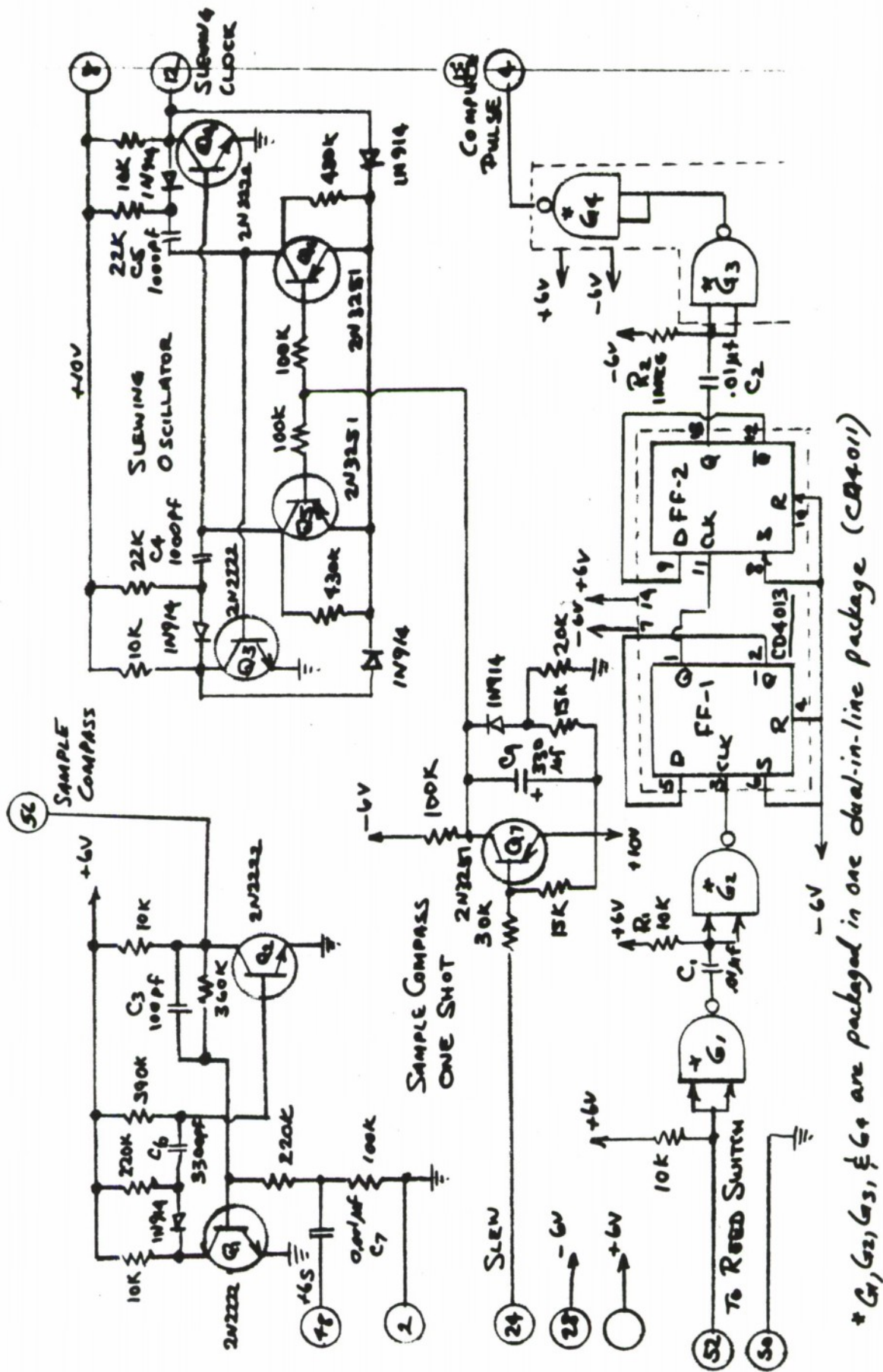

Figure 4-11 Channel Logic, Board (072), Schematic Diagram



*G₁, G₂, G₃, & G₄ are packaged in one dual-in-line package (CA4011)

FIGURE 4-12. DISTANCE INCREMENT AND CONTROL CARD



4.2.5.2 Distance Increment Input Circuit

The distance input for the LVN is derived from the vehicle odometer cable. For an APC the odometer cable rotates 1000 rev/mile or 1.609 m/rev. A magnet rotating with the odometer cable causes a reed switch to open and close once per revolution of the cable. This results in a train of pulses at the input of G_1 (See Figure 4.12). R_1 , C_1 , and G_2 forms a one-shot which is triggered by the negative edge of the incoming pulses. The purpose of this one-shot is to eliminate false counts due to contact bounce or noise in the reed switch. The resulting pulse train is then counted down by four by FF-1 and FF-2 resulting in a square wave whose period is one fourth that of the odometer cable. R_2 , C_2 , and G_3 form another one shot which changes the square wave to a train of 10 msec pulses. G_4 is a driver to provide the compute command to the system. Each compute pulse represents a distance travelled of 6.436 meters per count. Therefore, the system adds 6.436 meters resolved into the proper heading.

The compute pulse is sent to the control and filter board where a power on reset is generated which drives the sample compass one shot. This generates the sample compass pulse to start the ramp in the resolver circuitry and the compute cycle.

4.2.6 The Calibrate Circuitry

The calibrate circuitry is used to determine, "remember", and apply a feedback current to the compass sense windings in order to provide a compensating magnetic field to cancel out the effect of a magnetic disturbance. Two zero crossing detectors for each channel indicate when a sense winding passes through a null. This indication is used to enable a sample and hold of the voltage on the other coil. For a complete revolution of the vehicle, each coil passes through two nulls resulting in two voltages being stored for each coil. These two pairs of voltages are then averaged, resulting in two voltages which are representative of the lateral and longitudinal components of the disturbance. These voltages are then used to drive a servo loop which stores them indefinitely and, in effect, forms a non-volatile memory. The stored voltages are then used to drive two Howland current sources which apply the feedback currents to the sense windings.



4.2.6.1 Detailed Description

When the calibrate switch is pressed, a one shot (See Figure 4.13) generates a calibrate pulse which is used to turn off the AGC on the compass processor board (See Figure 4.6) and to reset relays K_1 , K_2 , K_3 , K_4 , K_5 and K_6 to the positions shown in Figure 4.14. When the calibrate switch is pushed, the N phase detector output is applied to C_5 and C_6 and the E phase detector is applied to C_7 and C_8 . (See timing diagram, Figure 4.15). Whenever the north output goes from positive to negative (t_1), the output of Z_3 changes from negative to positive triggering the one shot (G_3 , R_3 and C_3), causing Q_3 to turn on and switching K_3 to its alternate state. This causes C_7 to store the East voltage at the North zero crossing. Similarly when the East voltage goes from positive to negative (t_2) Z_1 , G_1 , Q_1 and their associated circuitry cause K_1 to switch and the N voltage at t_2 to be stored on C_5 . Also, when the N and E coils change from negative to positive (t_3 and t_4) the N output at t_4 is stored on C_6 and the East output at t_3 is stored on C_8 . Four indicator lamps (L_1 , L_2 , L_3 , and L_4) come on when the calibrate switch is activated and go out as K_1 , K_2 , K_3 , and K_4 switch to indicate to the system operator that the data has been taken. CR_1 , CR_2 , CR_3 , and CR_4 form a NAND gate which causes the voltage on R_{29} to change from -6 volts to ground when all four relays have switched. This results in the one shot composed of G_5 , R_{21} , R_{22} , R_{22} and C_{11} being triggered, turning on Q_8 and switching K_5 to the alternate state. When K_1 and K_2 have switched, the voltages on C_5 and C_6 are averaged in R_9 and R_{10} and when K_3 and K_4 switch the voltages on C_7 and C_8 are averaged in R_{11} and R_{12} . These two average voltages are representative of the lateral and longitudinal components of the disturbance. When relay K_5 is switched, these two voltages are fed into Z_5 and Z_6 . Z_5 and Z_6 are FET input OP AMPS with very high input impedances so that the capacitors (C_5 thru C_8) are not discharged. Z_5 , Q_5 , Q_6 , the motor (M_1), gear train (G_1), R_{24} , and their associated circuitry form a servo-loop which cause the wiper of R_{24} to move in such a manner that the voltage on pin 2 of Z_5 is equal to the voltage on pin 3 of Z_5 . Z_6 , Q_7 , Q_9 , G_2 , M_2 , and R_{23} form a similar servo loop for the East channel. The voltage levels now on the wipers of R_{24} and R_{23} are proportional to the lateral and longitudinal components of the disturbance.

After the servo loop has settled (1 second), the calibrate switch is pushed to the off position activating one shot G_6 and switching K_6 through Q_{10} . When K_6 switches the motor inputs



-6Z REGULATOR

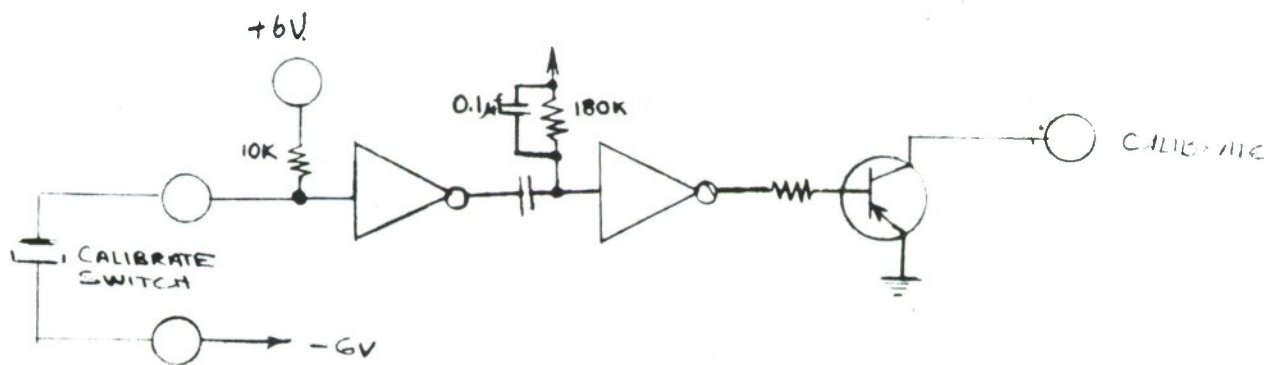
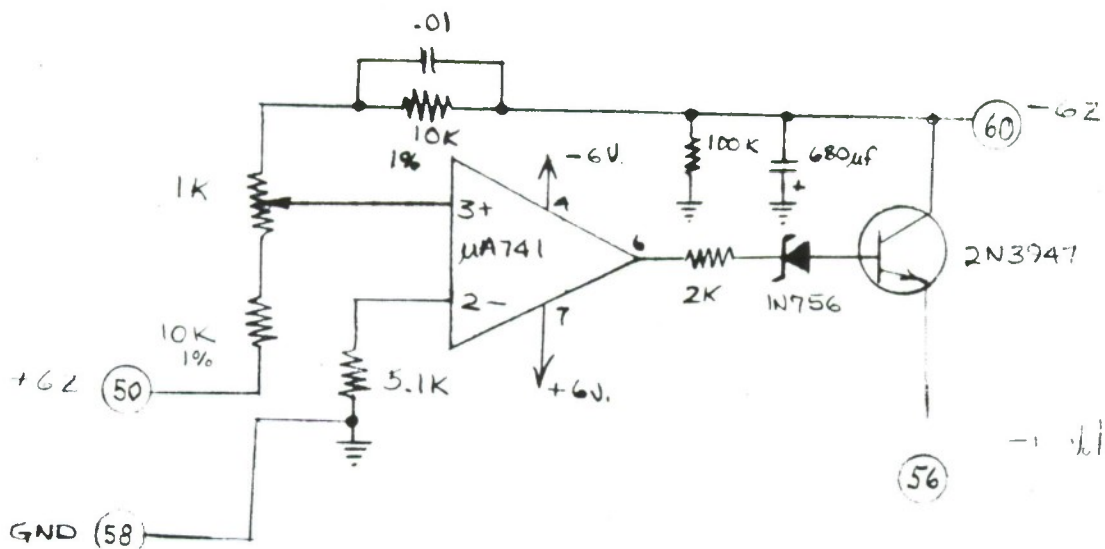

FIGURE 4-13 CALIBRATE START CIRCUIT

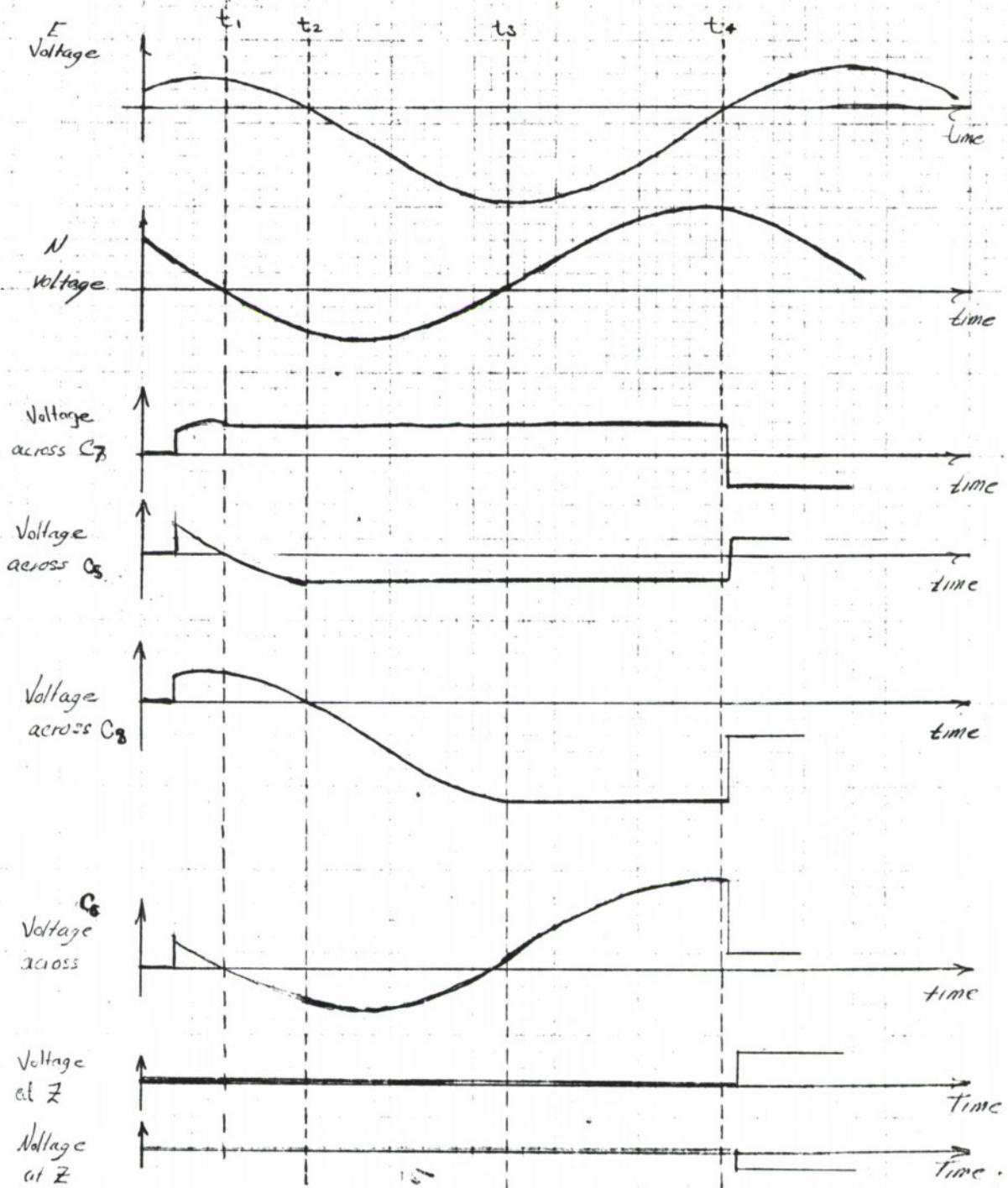

FIGURE 4-15 CALIBRATOR TIMING DIAGRAM



are grounded and the AGC on the compass processor card is enabled. The pots R_{23} and R_{24} now store the calibration voltages in non-volatile state. That is, even if the system power is turned off and on, the calibrate voltages will remain.

Z_7 and Z_8 are buffer amplifiers to prevent loading of the servo loops. Z_9 and Z_{10} and their associated circuitry form Howland current sources which put a current into the sense windings proportional to their respective inputs (the calibrate voltages). R_{27} and R_{34} are used to adjust the voltage-to-current transfer ratio of the current sources to the correct value.

4.2.7 Power Supply

The LVN is powered by three Gel/cell rechargeable batteries each having a capacity of 2.5 ampere hours. The system can be operated about eight hours without recharging the batteries. The power supply card is taken from the AN/PSN-5, but, only the voltage doublers, the +6Z regulator, the 80 KHz differentiator and power switches are used. (See Figure 4.16.) The power supply card contains two voltage multipliers: a voltage doubler and a voltage tripler. The voltage doubler generates the -10 volt source. The voltage tripler generates +15 volts which is used to generate the +6Z precision reference using a Fairchild μ A723C voltage regulator.

The switched supplies are used on the LVN, not to conserve power, but because they form an integral part of the compute cycle of the AN/PSN-5 and unnecessary redesign would be required to eliminate them. For a detailed description of the power supply card as originally used refer to AN/PSN-5 final report.

4.3 DISPLAY AND CONTROL UNIT

The display and control unit is a modified AN/PSN-5 Handset. Refer to Figure 4-17 for schematic. The vehicle navigator uses the E/N four digit readouts of UTM coordinates with the least significant bit equal to 10 meters in the highest resolution mode and 100 meters in the lowest resolution mode. The counters can be illuminated by depressing a pushbutton on the right side of the case. The counters may be slewed to any desired coordinate using the toggle switches marked RT and UP. The distance calibrate control is used to compensate for vehicle differences in ratio of resolution per mile of the odometer pickoff. The remaining controls and indicators on the handset are not used in the vehicle navigator.

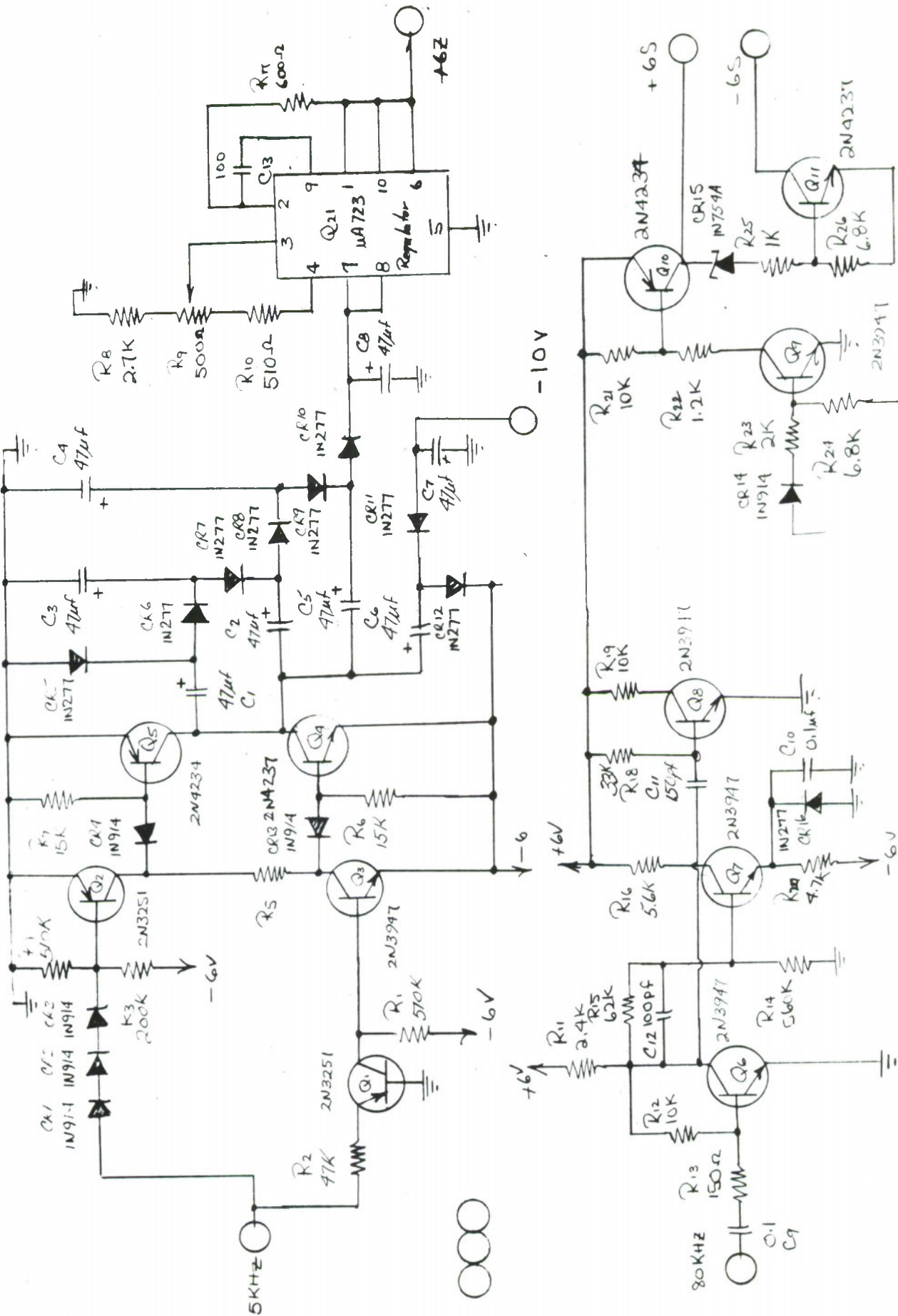

FIGURE 4-16 POWER SUPPLY CARD

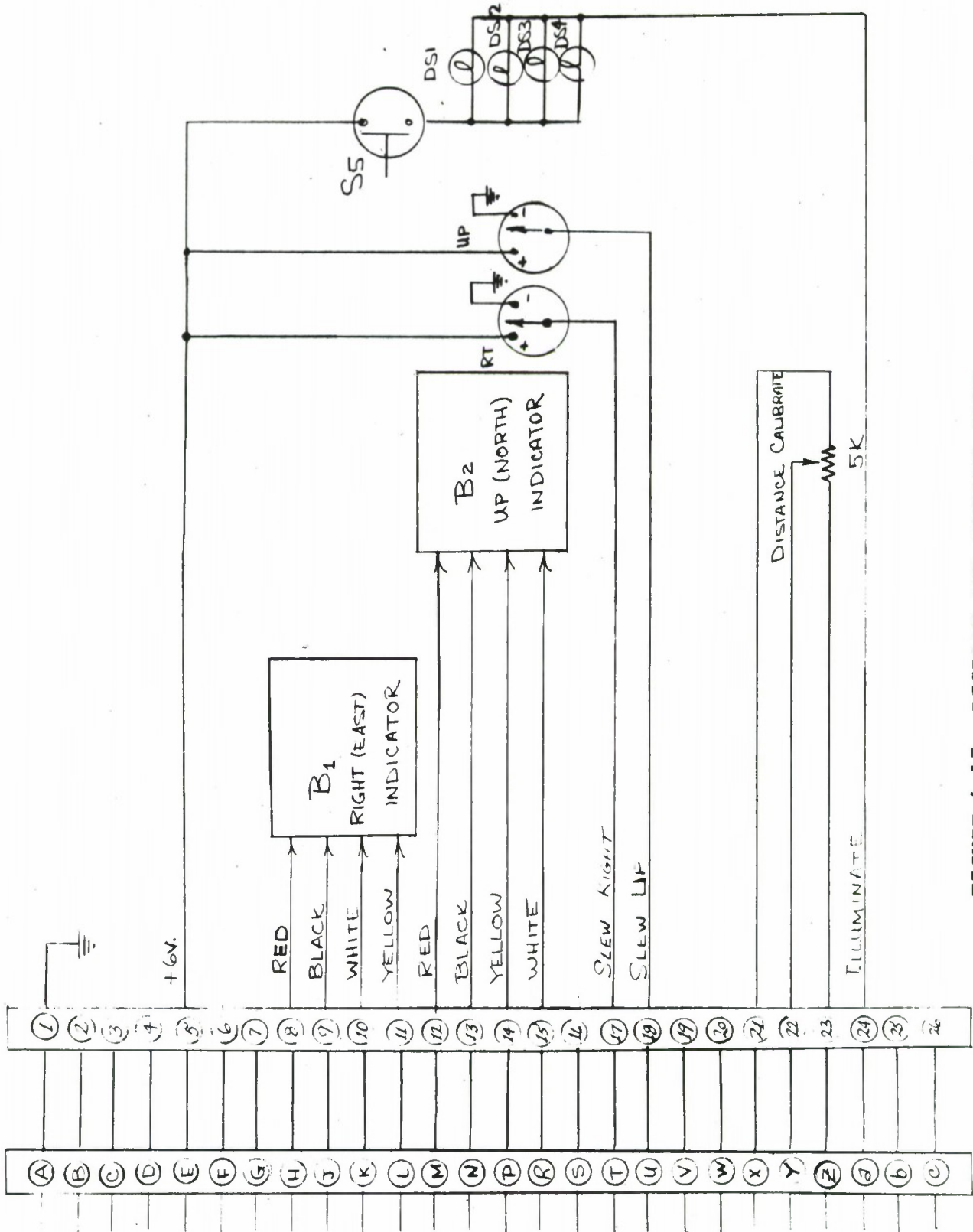

FIGURE 4-17 DISPLAY AND CONTROL UNIT



4.4 HEADING INDICATOR

The heading indicator uses a standard aircraft readout with a buffer amplifier between the readout and the compass processor. (See Figure 4.18) The East and North voltages from the compass processor are fed into OP AMPS Z_1 and Z_2 which provide a high impedance in order to prevent loading of the compass processor outputs. Q_1 , Q_2 , Q_3 and Q_4 provide push-pull drivers to drive the delta oriented coils in the readout.

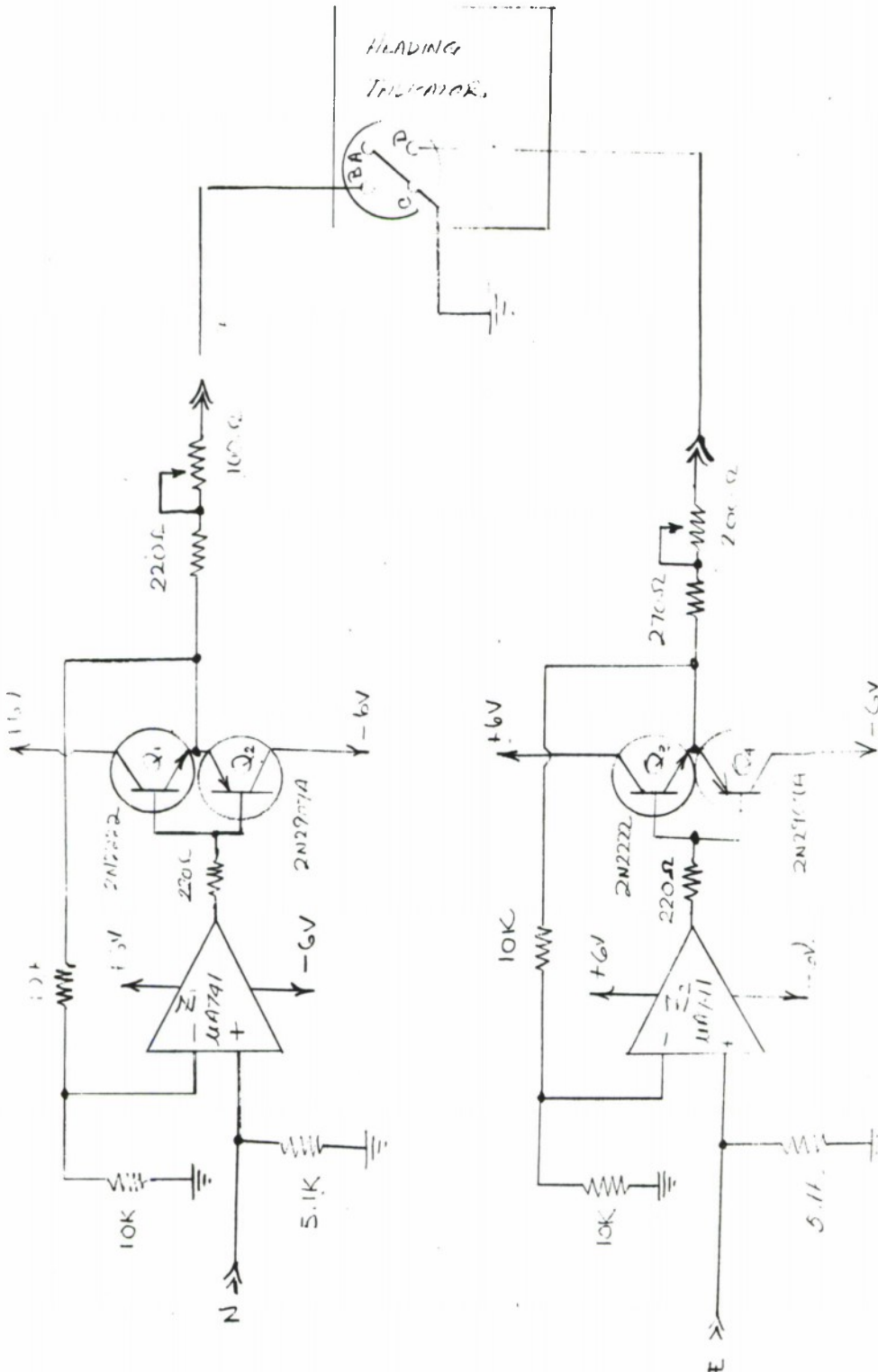

FIGURE 4-J8 HEADING INDICATOR SCHEMATIC



5.0 MECHANICAL DESIGN

5.1 COMPASS AND COMPASS MOUNT

The compass is suspended from a boom at the rear center of the vehicle. The boom is attached to the vehicle by removing the existing ventilator dome on the APC and replacing it with the dome and boom assembly provided with the LVN. See Figures 5-1 and 5-2. The dome and boom are mounted so they do not interfere with normal operation of the vehicle and all doors and hatches may be used normally. The dome is made from aluminum and the boom is of aluminum channel. The cable from the compass is fed along the inside of the channel for protection from damage.

5.2 DISPLAY AND CONTROL UNIT

The display and control unit is taken directly from the PSN/5 and is not modified mechanically. It consists of a waterproof aluminum can. The control panel is made of Lexan and contains waterproof switches and knobs. The panel may be illuminated by edge-lighting which is activated by the button on the side of the unit.

5.3 HEADING INDICATOR

The heading indicator consists of a standard aircraft heading indicator mounted in an aluminum chassis along with its associated circuitry. The heading indicator is connected to processor package by a 12' cable so it may be used in the drivers compartment.

5.4 PROCESSOR

The processor circuitry is housed in a modified AN/PSN-5 backpack. The card rack and connectors are taken directly from the PSN-5 unit. Six of the eleven circuit boards are taken directly from the PSN-5 while the remaining five are vector board style breadboard units. The space formerly used by the PSN-5 compass is used for the batteries and the calibrate servo mechanism in the LVN. The top panel has been modified to provide the necessary controls and indicators used on the LVN.

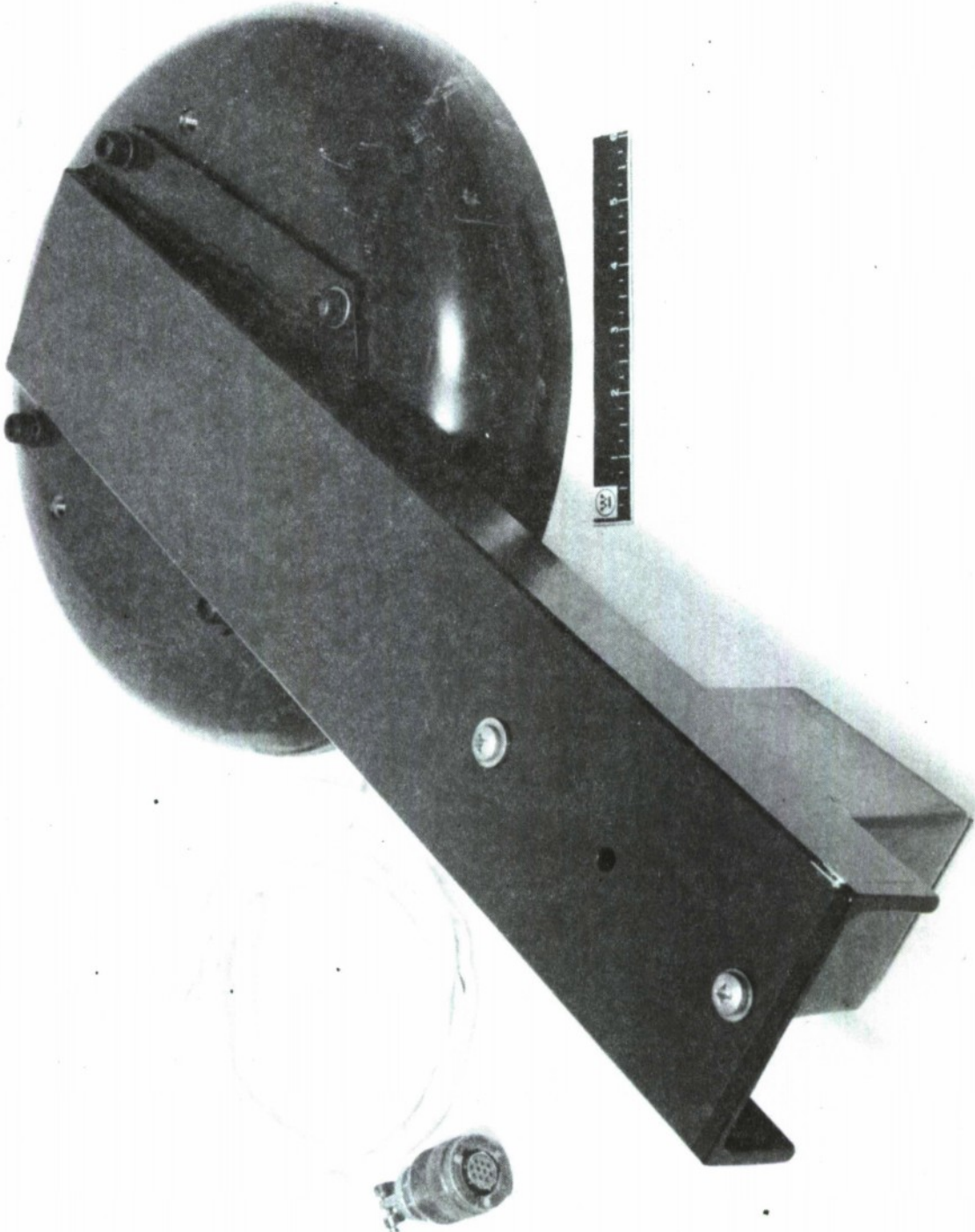

FIGURE 5-1 COMPASS AND COMPASS MOUNT



FIGURE 5-2. COMPASS MOUNTED ON APC



6.0 TESTS

6.1 TEST PHILOSOPHY

A test plan was formulated to determine the system accuracy and the system limitations. Initially a series of laboratory tests were performed on all system functions. In these tests it was attempted to simulate field conditions as accurately as possible, in order to eliminate as many problems as possible during the field tests. In order to achieve a 2% system accuracy goal, a compass accuracy of better than 1° is required; therefore the compasses were aligned on the bench to have a 1° or better error in cardinal and intercardinal directions. Ideally a test course with straight runs of one Kilometer or more in the cardinal and intercardinal directions is desirable for accurately pin pointing system problems. Also a compass rose must be set up to align the vehicle accurately in the cardinal and intercardinal directions to check compass accuracy. The compass rose area must be entirely free of magnetic disturbance in order to avoid erroneous results. Minor disturbances along the road course may be tolerated as these would tend to average out over a closed course or be insignificant as compared to the total distance travelled.

6.2 LAB TESTS

During the lab test phase field conditions were simulated as nearly as possible. The compass was aligned on a turntable to better than 1° on all cardinal and intercardinal directions. The data for all eight directions was then plotted on a heading circle so that the compass accuracy was readily visible. Figure 6.1 is an actual plot made from data on the first system compass. To test the calibrate circuitry a small magnet was placed on the turntable near the compass. Data was then taken in all eight directions to determine the error introduced by the disturbance. The calibrate procedure was simulated by pushing the calibrate switch and slowly rotating the turntable 360 degrees. Data was then taken in all eight directions to determine the calibration accuracy. A heading circle plot of corrected and uncorrected data is shown in Figure 6.2.

6.3 FIELD TESTS

Initial field testing was performed at Aberdeen Proving ground. A map of the test course is shown in Figure 6.5. A compass course was set up using a transit and stakes to align the vehicle in the cardinal and intercardinal directions. The vehicle was aligned by sighting along the side of the vehicle and aligning the side of the vehicle with two stakes in line with the desired heading. It was found that using this method the vehicle alignment could be repeated to within half a degree.

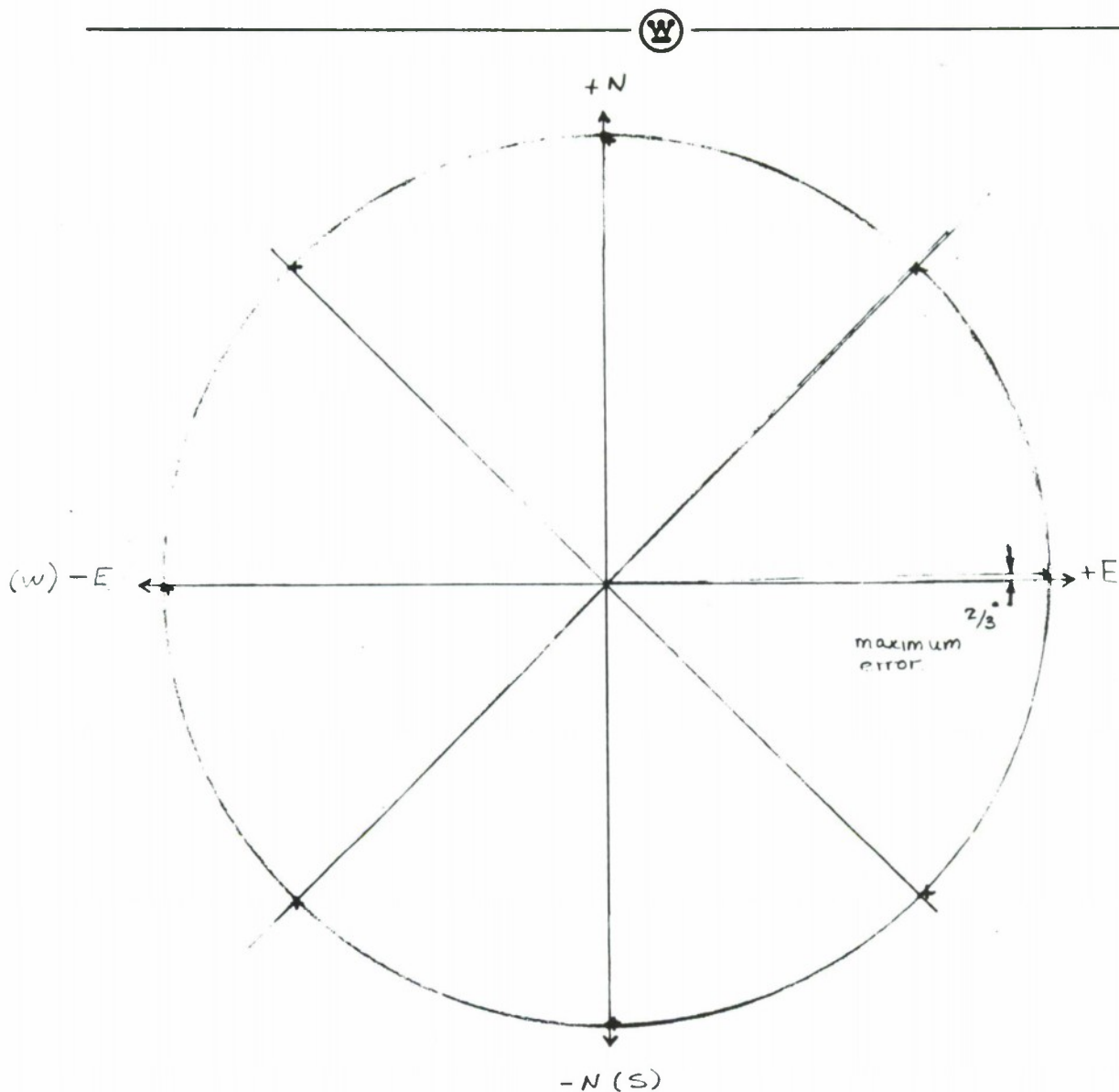

+ HEADINGS AS INDICATED BY COMPASS
 • ACTUAL HEADING.

ACTUAL HEADING	E (volts) COMPASS OUTPUT	N (volts) COMPASS OUTPUT
0°	+0.016	+1.989
45°	-1.400	+1.405
90°	-1.989	-0.020
135°	-1.408	-1.418
180°	+0.017	-1.990
225°	+1.433	-1.394
270°	+1.992	+0.022
315°	+1.416	+1.390

FIGURE 6-1 HEADING CIRCLE WITHOUT DISTURBANCE PRESENT

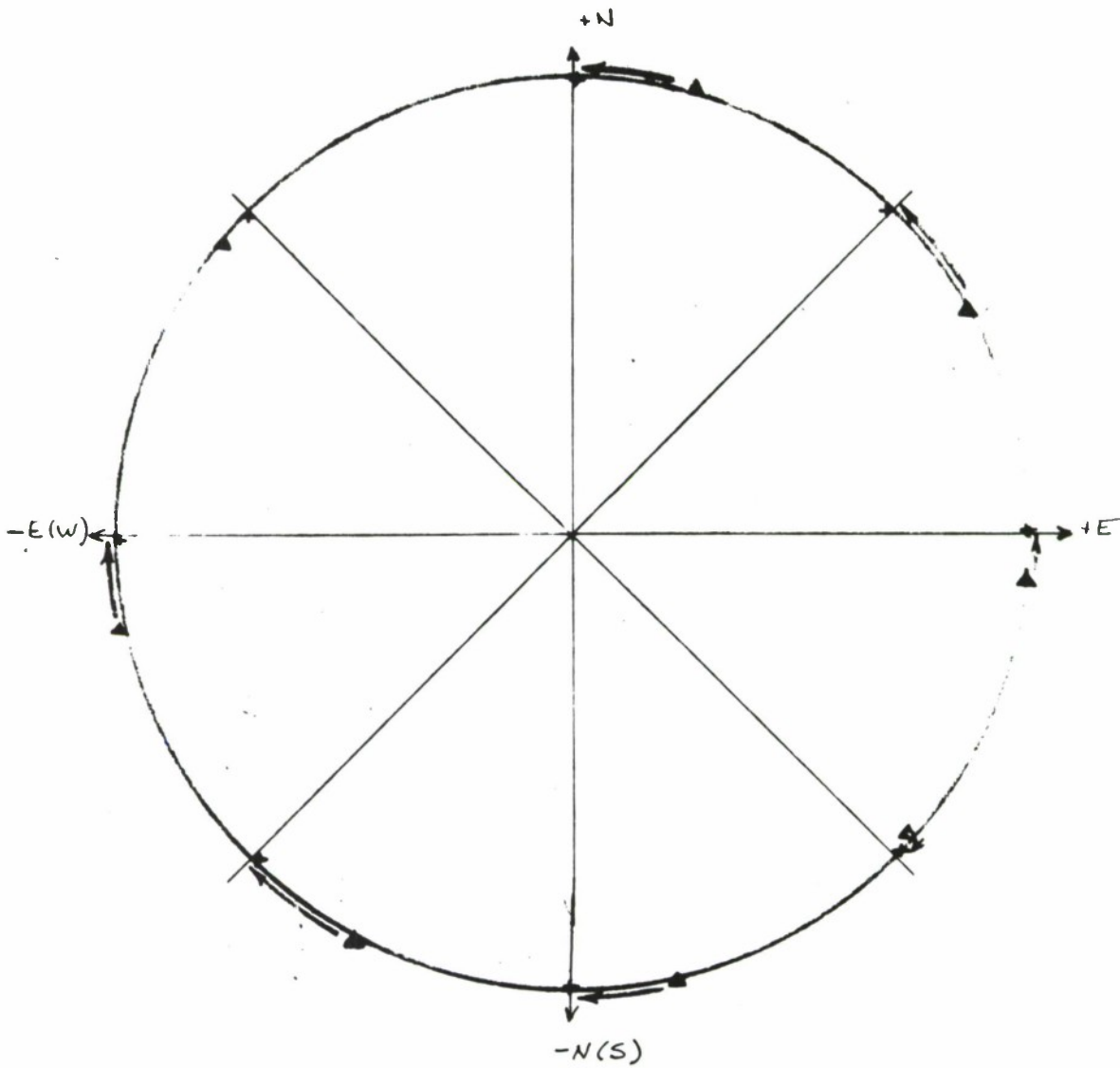

Actual Heading	Compass Headings Uncalibrated		Compass Headings Calibrated	
	E (volts)	N (volts)	E (volts)	N (volts)
0°	+0.547	+1.925	+0.014	+1.990
45°	-1.297	+1.511	-1.412	+1.390
90°	-1.990	-0.396	-1.991	-0.024
135°	-0.944	-1.792	-1.426	-1.395
180°	+0.470	-1.957	-0.012	+1.988
225°	+1.544	-1.314	+1.424	-1.402
270°	+2.000	-0.199	+1.993	+0.018
315°	+1.726	+0.987	+1.387	+1.418

Δ UNCOMPENSATED

+ COMPENSATED

FIGURE 6-2 HEADING CIRCLE WITH DISTURBANCE



The magnetic disturbance of the vehicle at the compass location was measured by opening the compensation current feedback loop and disabling the AGC on the compass processor. Thus, the phase detector outputs are representative of the intensity and direction of the ambient field at the compass. The vehicle was then oriented in each cardinal direction and the voltages at the phase detector outputs recorded. This data was then plotted as shown in Figure 6.3. A circle drawn through these data points will have a radius proportional to the earth's magnetic field (H_e) and its center will be removed from the origin a distance proportional to the disturbing field (point A). From Figure 6.3 it can be seen that the disturbance at the compass location is about one fifth the magnitude of the earth's field and is aligned along an axis 20° from a line perpendicular to the vehicle heading. This disturbance is well within the calibration range of the LVN.

The system was then calibrated by driving the vehicle in a circle. A large number of calibrations were made to establish the optimum technique. It was found that the vehicle should be driven as smoothly and slowly as possible. If these precautions are taken the system would repeatedly calibrate the disturbance out to about 1° compass accuracy. In all cases however the overall compass accuracy was improved by an order of magnitude over the uncalibrated compass. Figure 6.4 shows the effect of calibration on the cardinal heading on the APC used at Aberdeen. The calibration reduced the compass error from $16-1/2^\circ$ maximum to about 1° maximum.

A minor difficulty was discovered at this time with the calibrate procedure. It was found that when a null point on the circle was crossed it could not be immediately recrossed without causing erroneous data to be stored by the calibrator. Any tendency of the vehicle to sway or oscillate while crossing through a null results in several rapid crossings which the system interprets as more than one data point. This results in both data storage elements for the nulled coils being filled with the same data. This problem can be corrected with some additional logic circuitry which will be incorporated into any future systems.

After completing successful calibration of the compass on the static course, road testing was done. Road testing began by running the vehicle over the portion of the test course traced by points A, B, C, D, E. The results from these tests are plotted in Figures 6.5 and 6.6. Accuracy ranged from 1% to 5.6%. Upon careful analysis of the results and observation of the system phase detector outputs (heading) during the runs it was determined that a large portion of these errors was caused by magnetic disturbances along the course rather than

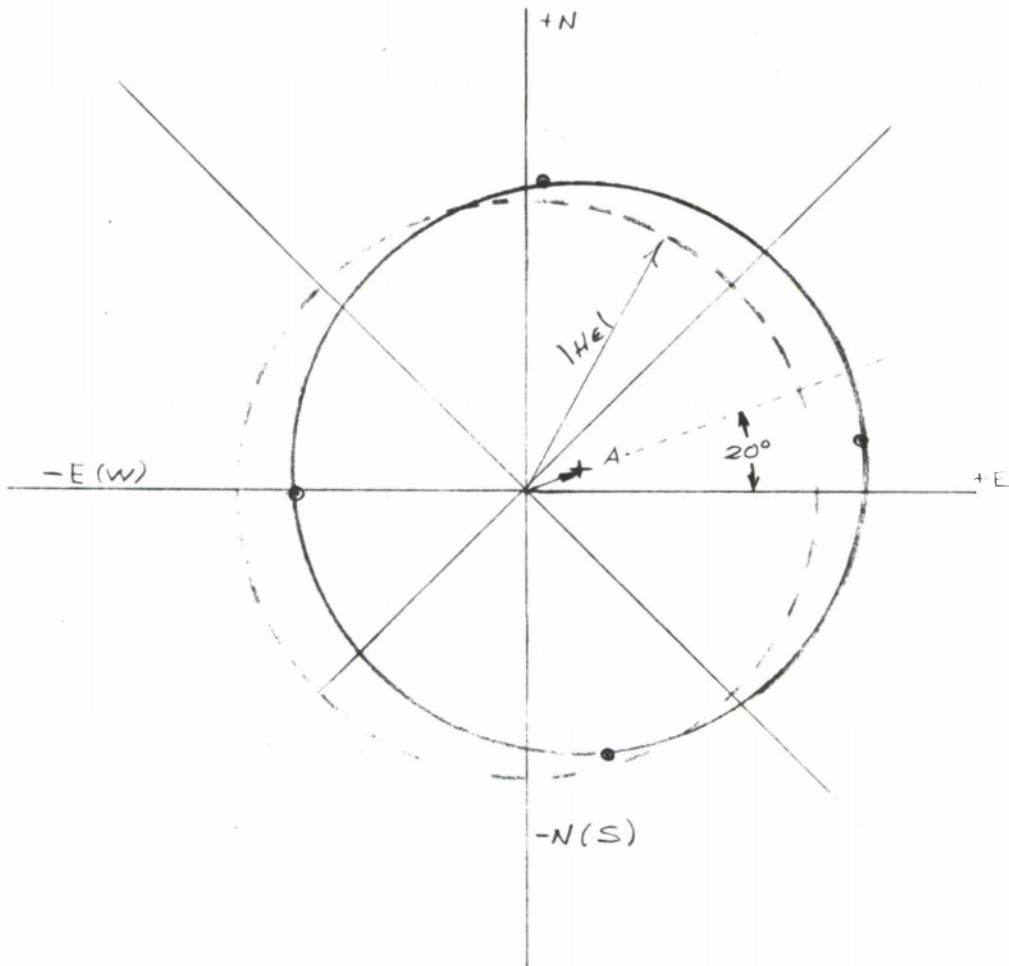

Vehicle Heading	E volts	N Volts
N	+0.09	+1.28
W	-0.96	-0.02
S	+0.35	-1.12
E	+1.40	+0.20

FIGURE 6-3 DISTURBANCE MEASURED ON APC

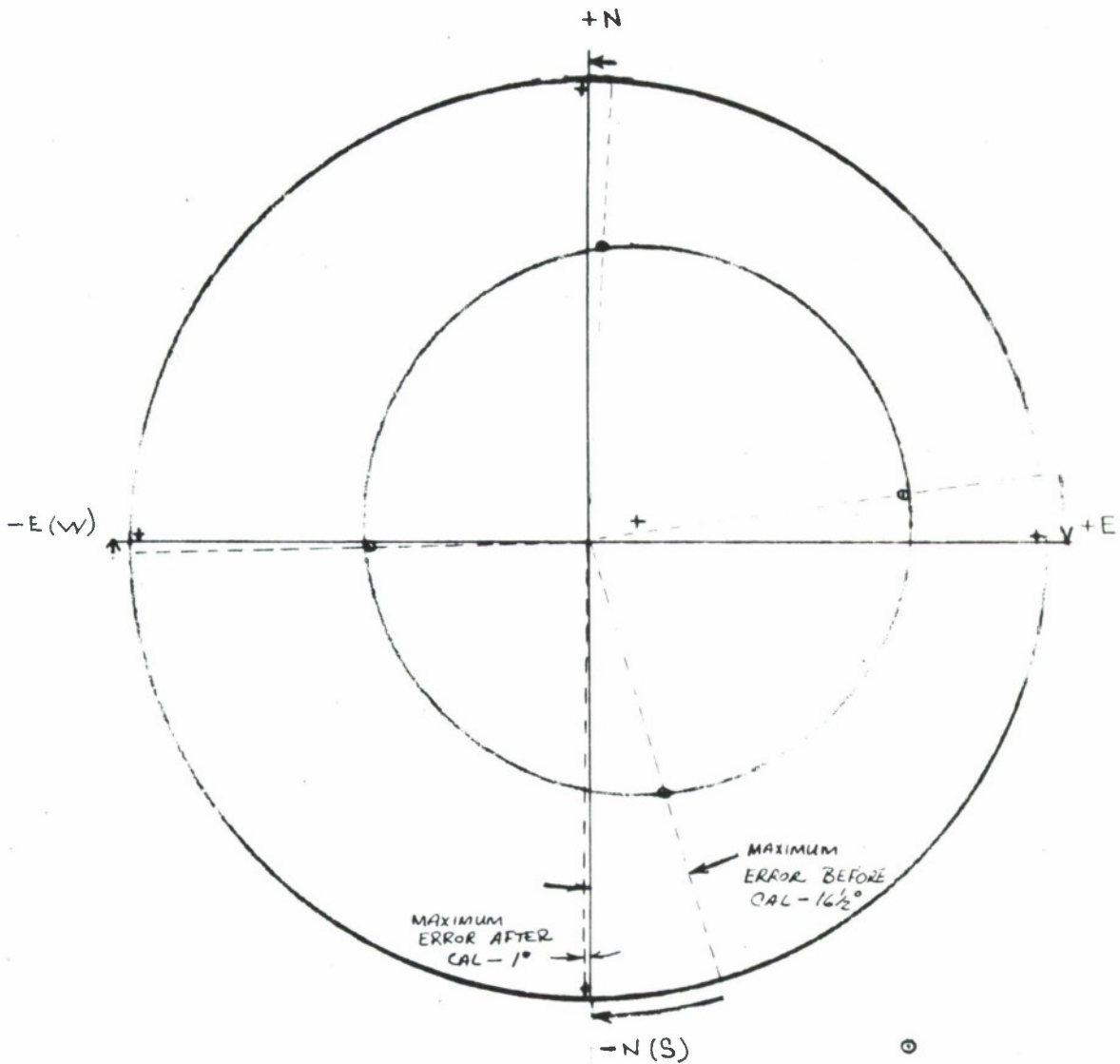

Vehicle Heading	E volts	N volts
N	-0.03	+1.96
W	-1.95	+0.03
S	-0.01	-1.96
E	+1.95	+0.03

FIGURE 6-4 HEADING CIRCLE ON APC BEFORE AND AFTER CALIBRATION

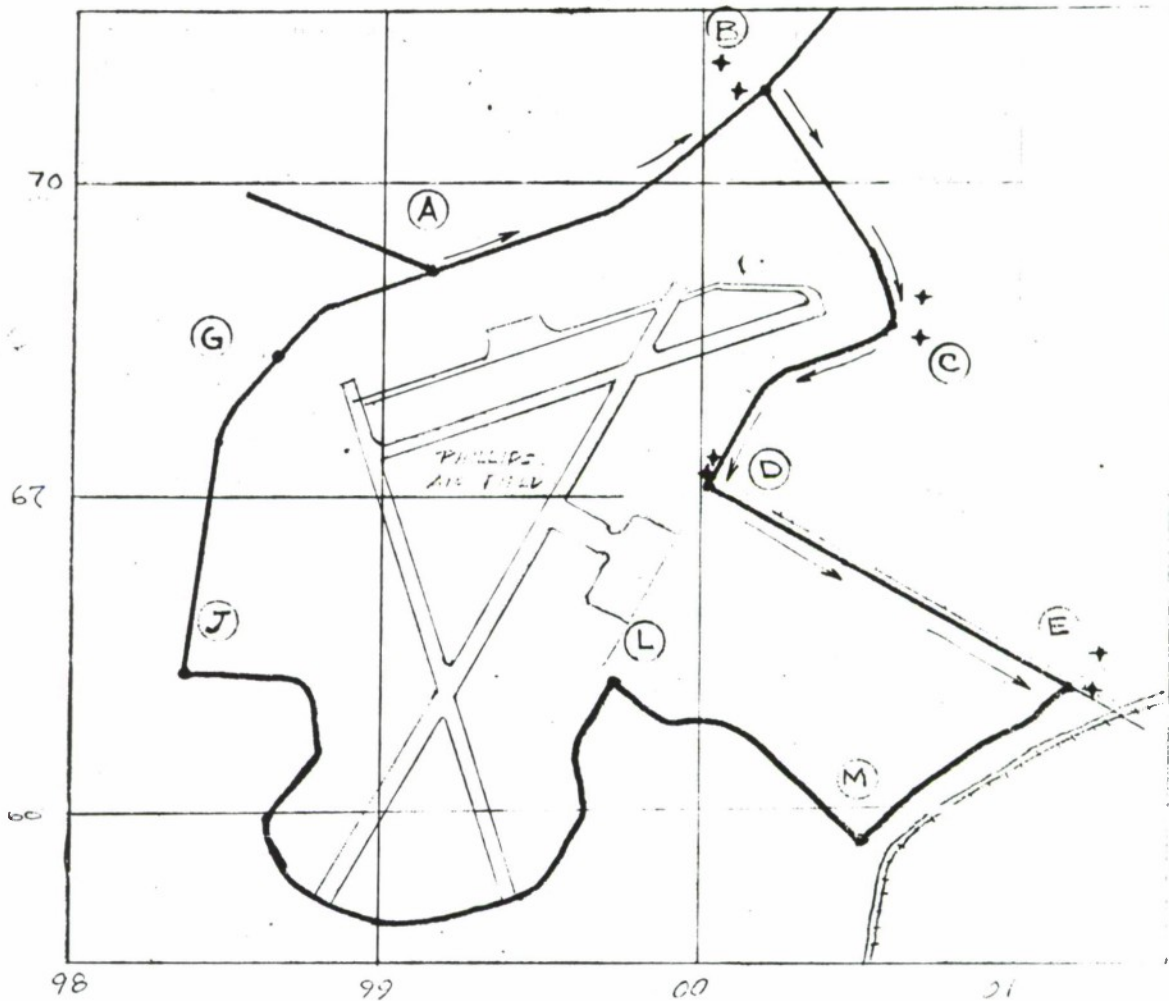

POINT	4/6/73				4/13/1973	
	A	9914	6970	1714	6970	9914
B	0018	7030	0006	7024	0003	7038
C	0059	6953	0068	6958	0067	6963
D	0001	6903	0001	6906	0001	6913
E	0116	6838	0122	6842	0122	6854

DISTANCE FROM A-E = 4.2 Km

ERROR @ E (TRIP I) = 65m or 1.5%

ERROR @ E (TRIP II) = 160m or 3.8%

FIGURE 6-5 APG COURSE DATA #1

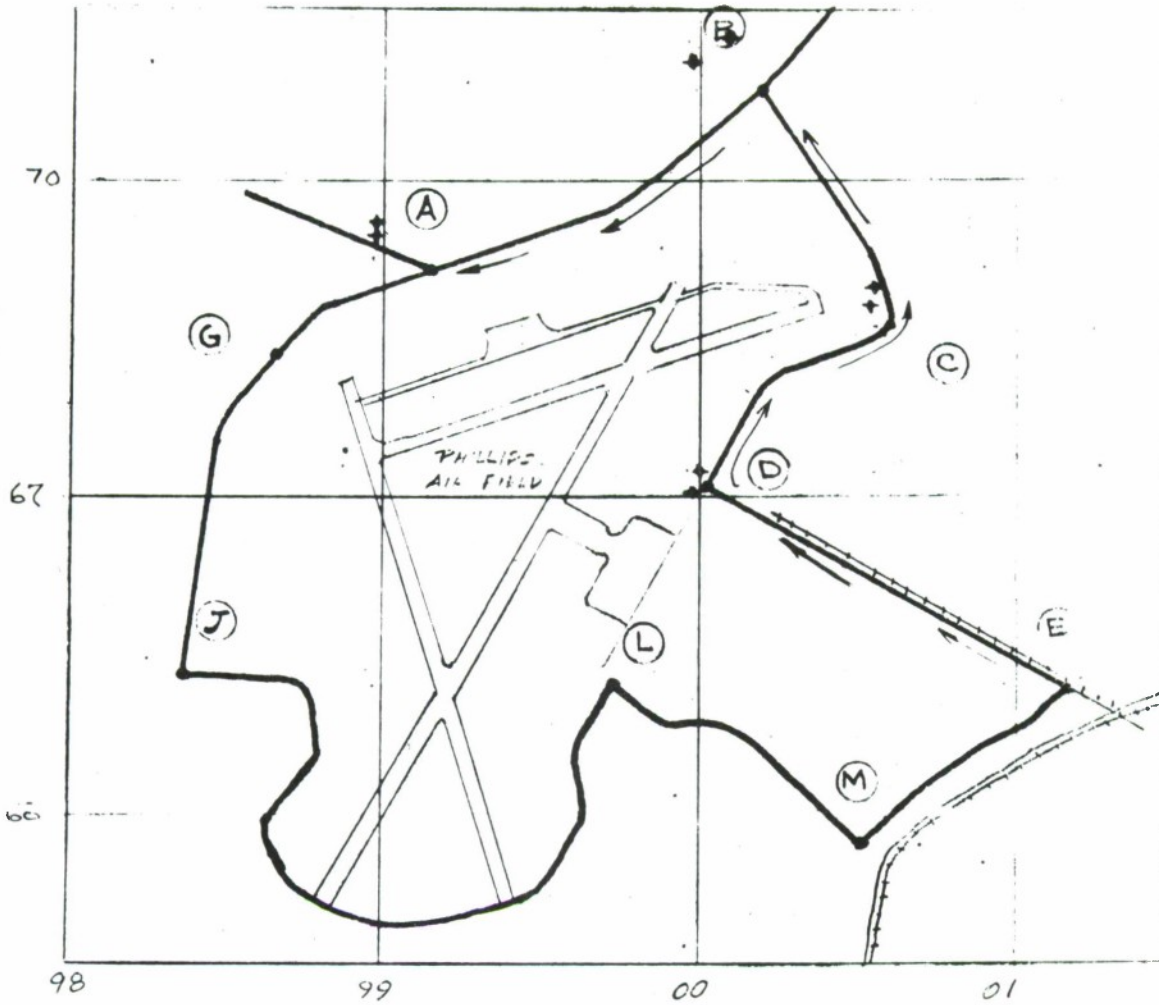

E	0116	6838	0116	6838	0116	6838
D	0001	6903	0000	6908	9997	6701
C	0059	6953	0055	6965	0052	6959
B	0018	7030	0007	7049	9992	7040
A	9914	6970	9898	6988	9895	6980

TOTAL DISTANCE E-A = 4.2 km

ERROR AT A (TRIP I) = 240M OR 5.6%

ERROR AT A (TRIP II) = 215M OR 5.1%

FIGURE 6-6 APG COURSE DATA #2



a system malfunction. Tests were then run over the path designated by A, G, J, L, M, E, as this path was mostly dirt roads and contained fewer possible magnetic disturbances such as pavement reinforcement and railroad tracks. The results of these runs are plotted on Figures 6.7, 6.8 and 6.9. Accuracies on these runs were between 0.8 and 2.5%, close to the contract goal of 1%. Even though results on this course were better, large disturbances along the course such as temporary runways (PSP) were observed. In addition it was felt that the airfield runways produced an overall disturbance for the entire test area.

It was then we decided that a test area with fewer magnetic disturbances was required. In addition it was also desirable to obtain an APC fully loaded up with equipment such as the machine gun, tools, spare tracks, jacks, etc. A trip was made to Fort Knox where these accommodations were readily available. Upon arrival a compass course was set up. The system was mounted on the vehicle. The vehicle was completely equipped with combat gear except ammunition. A driver and a track commander were provided. The vehicle was equipped with a two way radio which was used normally with no noticeable interference between the LVN and the radio. The vehicle was calibrated. The disturbance was at 21° from an axis perpendicular to the vehicle heading and its magnitude was about 10% of the earth's magnetic field. See Figure 6.10. Movement of the machine gun turret had a negligible effect on the LVN. In general all the gear loaded onto the vehicle seemed to have very little effect unless it was brought to the compass. The disturbances were calibrated out to within one degree. A second vehicle was used when the first one broke down. The disturbance for this vehicle was about 12% of the earth's field and is also plotted in Figure 10. This vehicle was used for the remainder of the test.

The terrain at the Fort Knox test sight was exceedingly hilly with winding dirt roads and thus, optimum system performance was not expected. However the LVN performed exceedingly well under these conditions registering consistently less than 2.5% error. A map of the Fort Knox road course is shown in Figure 6.11. Path A-B-C consists of regularly used dirt roads and is about 5.6 Kilometers long. The LVN registered errors of 2 to 2.3 percent from A to C and C to A. Closure from A to C and return was about 0.77%. Path A-B-E-F is a bulldozed path. The dotted line from F to G is an over land path that is exceedingly rough. A trip was made along this trail. The LVN continued to operate within 2% accuracy. At point G the vehicle became stuck concluding the test. The LVN at this point was still operating at 2%. It is also important to note that the LVN performed very consistently with no large errors on any part of the course. This further supports the feeling that the results of the Aberdeen testing were clouded by magnetic disturbances along the course. In addition, if the LVN can perform at a 2% accuracy on the type of terrain encountered, performance should be better this accuracy on more level terrain.

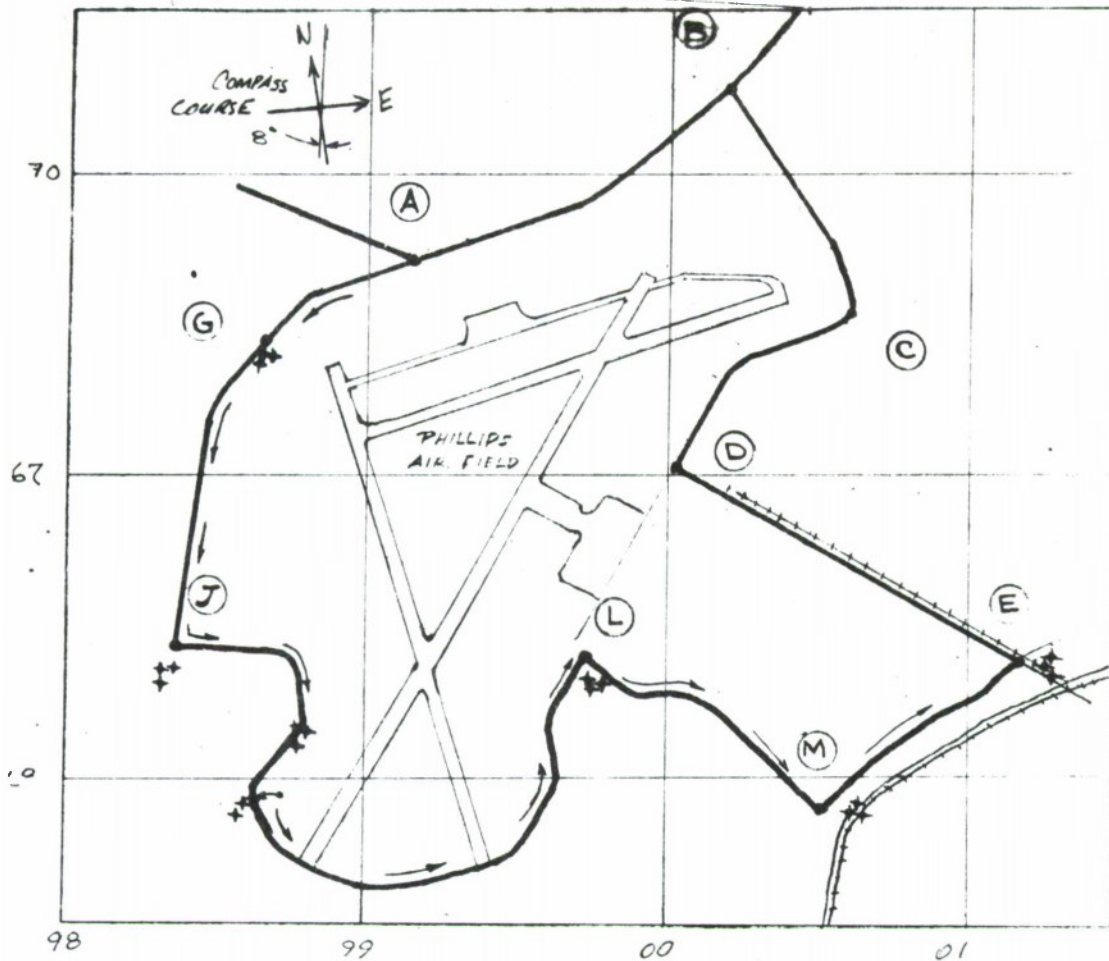

POINT	MAP COORDINATES		LVN DATA		LVN DATA		LVN DATA	
			A-G-J-L-M-E	TRIP I	A-G-J-L-M-E	TRIP II	A-G-J-L-M-E	TRIP III
A	9914	6970	9914	6970	9914	6970	9914	6970
G	9868	6949	9761	6941	9867	6940	9865	6940
J	9836	6893	9927	6832	9836	6837	9832	6736
L	9971	6893	9975	6831	9978	6832	9975	6832
M	0053	6792	0065	6788	0064	6784	0062	6786
E	0116	6838	0121	6837	0128	6830	0125	6833

TOTAL DISTANCE A to E = 6.1 KM

ERROR @ E (TRIP I) = 110m = 1.8%

ERROR @ E (TRIP II) = 150m = 2.5%

ERROR @ E (TRIP III) = 100m = 1.6%

FIGURE 6-7 APG COURSE DATA #3

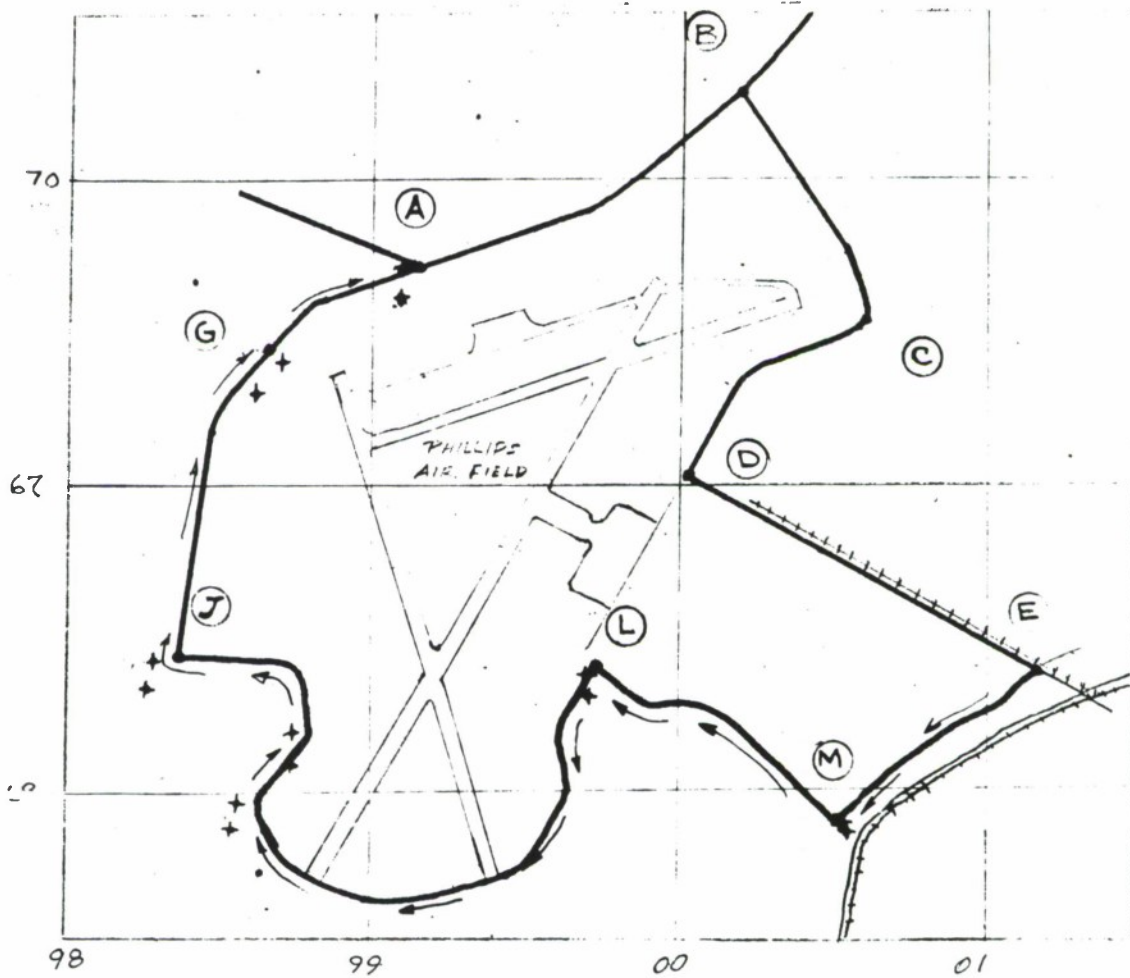

Point	Map Coordinates		LVN E-M-L-J-G-A		LVN DATA	
			Data TRIP I		E-M-L-J-G-A TRIP II	
E	0116	6838	0116	6838	0116	6838
M	0053	6792	0051	6789	0053	6785
L	1771	6843	9967	6837	7968	6829
J	9836	6843	9827	6841	9825	6829
G	9868	6749	9862	6939	9862	6928
A	9914	6970	9909	6968	9909	6957

Total distance E-A = 6.1 km.
 Error at A $(77.4\%) = 50m = .8\%$
 Error at A $(78.8\%) = 14m = 2.3\%$

FIGURE 6-8 APG COURSE DATA #4

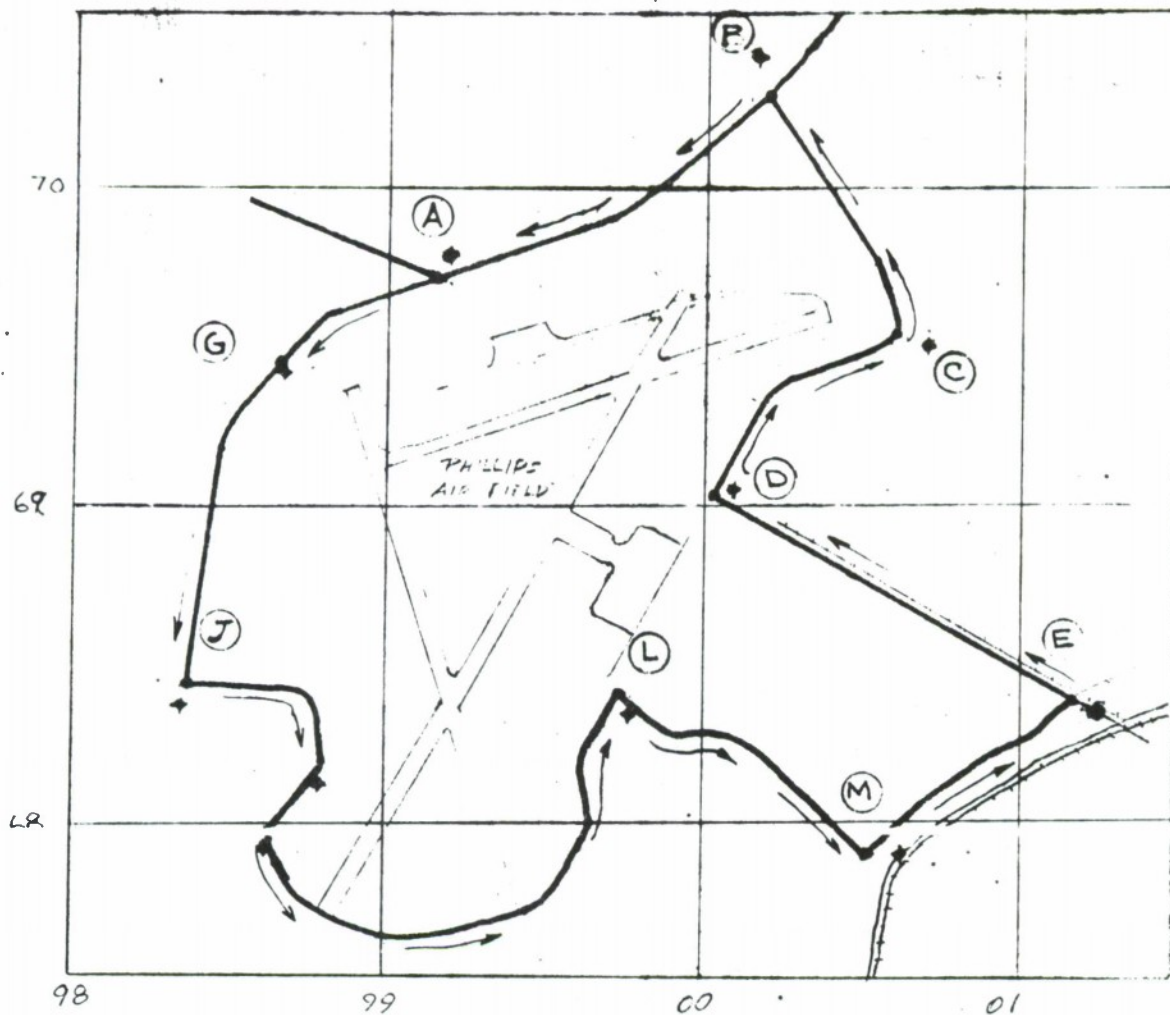

POINT	MAP COORDINATES		LVN DATA	
			A-G-J-L-M-E	-D-C-B-A
A	9914	6970	9914	6970
G	9868	6949	9865	6940
J	9836	6843	9832	6836
L	9971	6843	9975	6832
M	0053	6792	0062	6786
E	0116	6838	0125	6833
D	0001	6903	0008	6906
C	0059	6953	0069	6959
B	0018	7030	0011	7041
A	9914	6970	9919	6975

TOTAL DISTANCE AROUND COURSE :

10.3 Km.

Closure ERROR = 70 m. OR. 0.7%

FIGURE 6-9 APG COURSE DATA #5

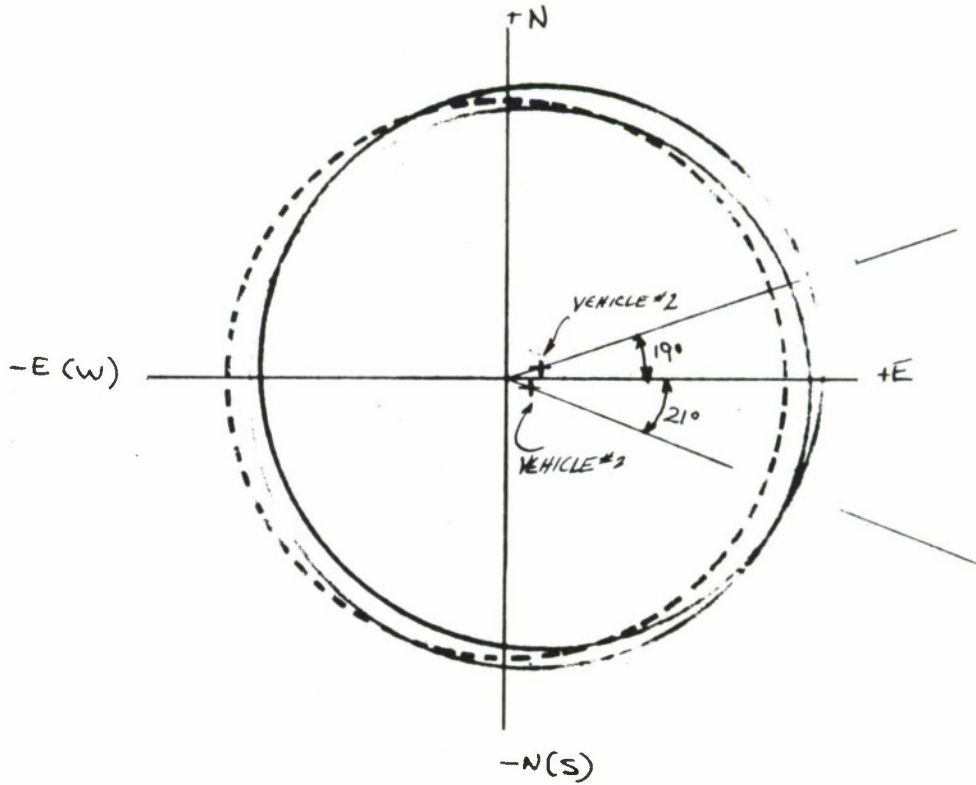
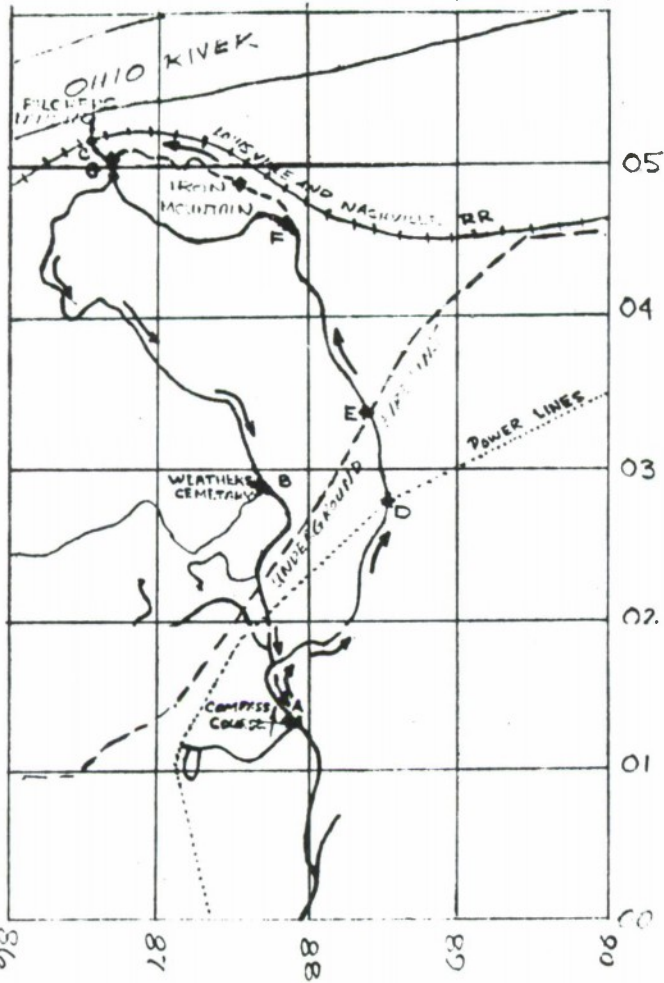

FIGURE 6-10 DISTURBANCES MEASURED ON TWO APC'S
FORT KNOX, KENTUCKY



	MAP COORDINATES	
A	8792	0130
B	8772	0287
C	8654	0519
D	8856	0280
E	8842	0338
F	8788	0151
G	8668	0495

POINT	MAP COORDINATES		LVN DATA A → B → C		DIST. ANCE	ERR
A	8792	0130	8792	0130		
B	8772	0287	8776	0282		
C	8654	0519	8656	0506	5.6Km	2.3%

POINT	MAP COORDINATES		LVN DATA C → B → A		DIST. ANCE	ERROR
C	8654	0519	8654	0519		
B	8772	0287	8765	0280		
A	8792	0130	8784	0138	5.6Km	2.0%

POINT	MAP COORDINATES		LVN DATA A → E → G		DIST.	ERROR
A	8792	0130	8792	0130		
E	8842	0338	8837	0335		
G	8668	0502	8665	0505	5.3Km	7.5%

FIGURE 6-11 FORT KNOX COURSE DATA

CLOSURE A-B-C-B-A- 10.9 Km
0.77% ERROR.



7.0 APPLICATION FOR OTHER VEHICLES

Because of the success of the LVN on APC's an additional out-of-scope study effort was added to this contract to evaluate the performance of the system when operating on other Army vehicles, in particular, jeeps and tanks. Tests and measurements were made on one Army jeep and one M48 tank. Static measurements of the magnetic disturbance for both these vehicles were made at Aberdeen, and road tests of the LVN navigational accuracy were made on-base and off-base for the jeep. The general conclusion was that the system, with some modifications, would probably perform well on the jeep and possibly on the tank. The principal difference between jeep or tank operation and APC operation was the presence of a slight amount of soft-iron disturbances on the jeep and considerably more on the tank. In addition, the magnitude of the PM disturbance was far greater on the tank and the effects of turret rotation on the tank were significant. In this section the results of the jeep and tank tests are given followed by a description of proposed modifications to the LVN that would enhance the jeep and tank operation.

7.1 JEEP

The LVN compass was mounted on the outside rear of a M151 jeep laterally centered and flush with the rear of the vehicle. The height of the compass was variable, and measurements were taken at two heights, (1) directly adjacent to the rear canvas support bar and (2) midway down the frame of the vehicle. Measurements were taken at the mid-position both with and without the spare tire normally carried at the right rear of the jeep.

The measurements taken directly adjacent to the support bar indicated that the disturbance at this point was greater than the earth's field and, hence, the LVN could not calibrate. A proposed correction to this system limitation is given later in this section.

Measurements midway down the rear of the vehicle showed a disturbance equal to about $4/10$ of the earth's field which could be compensated for by the LVN. The magnitude of the disturbance varied depending on whether the spare tire was present, but not significantly. In either case the LVN could compensate.

Static measurements of the disturbance without the spare tire are shown on the heading circle in Figure 7.1. The use of a heading circle to analyze a disturbance is explained in section 2 and the unfamiliar reader is referred to this section. Analysis of this data indicates the presence of a PM disturbance equal to about $4/10$ of the earth's field. Also indicated is a slight ellipticity indicating some soft-iron.

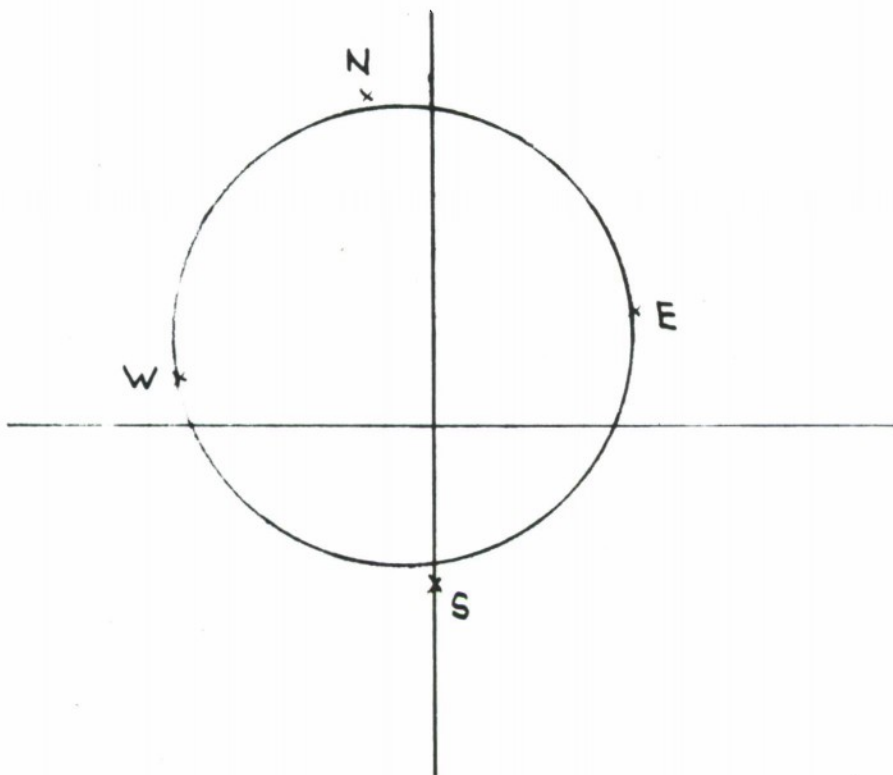

FIGURE 7-1 JEEP HEADING CIRCLE WITH DISTURBANCE

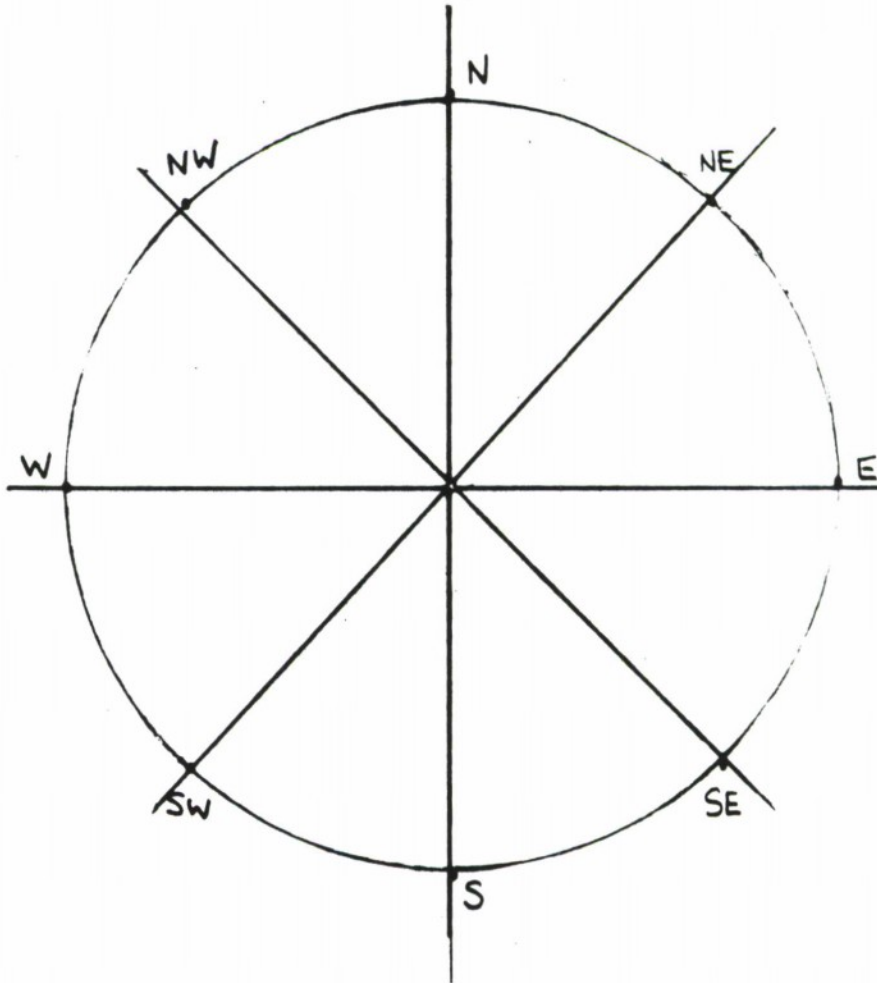

FIGURE 7-2 JEEP WHEN CALIBRATED



After calibration of the vehicle the static data heading circle was as in Figure 7.2. This circle is normalized by the system AGC to a 2 volt radius. Notice that there is a tendency for the intercardinal points to be pulled ever so slightly along the north/south axis. This indicates the presence of horizontal longitudinal soft-iron, probably associated with the body of the jeep itself.

The presence of this soft-iron was also confirmed by road tests off-base with the jeep. When the vehicle headed in any cardinal direction the LVN gave an accuracy of within 2%. In the intercardinal directions however there was a consistent error in the direction of the north/south axis.

As explained in Section 2 the presence of longitudinal soft-iron can be compensated by lateral soft-iron. A 4" piece of 3/4" diameter soft-iron pipe was fastened to the outside right of the compass box (approximately 3" away from the sense windings). As expected this lateral soft-iron tended to compensate the longitudinal soft-iron thereby improving the intercardinal headings.

Road tests were also run with the compensating soft-iron present, but because of the compass swinging on its pendulum mount as the vehicle assumes a tilt, the distance of the sensor to the compensating soft-iron varied to an extent that upset the compensation.

7.2 PROPOSED SOLUTION

The principal difficulty in operating the LVN on a jeep was the presence of a soft-iron disturbance for which the LVN could not compensate. In addition there was the minor difficulty that the PM disturbance was greater than the earth's field when the compass was mounted directly adjacent to the canvas support. Both of these difficulties can be overcome by a modification to the LVN.

As was explained in Section 2, the effect of symmetrical longitudinal soft-iron is to distort the heading circle into an ellipse whose major axis lies in the direction of the disturbance. It becomes readily clear, then, that such a disturbance can be compensated for by reducing the gain of the orthogonal sensor that lies in the direction of the soft-iron. If the gain in this probe is appropriately reduced, the output of this probe can be smaller in order to make up for the field enhancement by the soft-iron. Thus the heading ellipse can be compressed into an accurate circle again.



A block diagram of the implementation of an automatic scheme to adjust the sensor gains in order to compensate soft-iron disturbances is shown in Figure 7.3. This technique replaces the null detectors used in the present LVN with maximum and minimum detectors. Thus as the vehicle is driven in a calibration circle, the maximum and minimum values of the orthogonal sensors A and B are stored. For the correction of a PM disturbance this has the same result as the null storage technique. Referring to Figure 7.4 it can be readily seen that the components of the disturbance can be found as before except using the maxima and minima. Thus,

$$H_{d_A} = \frac{A_{MAX} + A_{MIN}}{2} \quad (7.1)$$

and

$$H_{d_B} = \frac{B_{MAX} + B_{MIN}}{2} \quad (7.2)$$

For soft-iron correction two additional factors are calculated to ascertain the ellipticity of the heading circle. These are

$$A_{AXIS} = A_{MAX} - A_{MIN}$$

and

$$B_{AXIS} = B_{MAX} - B_{MIN}$$

If these additional factors are equal, no soft-iron correction is required. If there is a difference the gain ratio of the sensors must be varied to compensate for the difference. Thus the desired system gain ratio is

$$G = G_B / G_A = \frac{A_{MAX} - A_{MIN}}{B_{MAX} - B_{MIN}}$$

This gain ratio is implemented in Figure 7.3 by including a Z1 gain stage in channel B whose gain is controlled by variable resistive elements that are varied in proportion to the gain ratio equation. Thus, when the servo loops are settled out during the calibrate procedure, the value of R_1 is proportional to $B_{MAX} - B_{MIN}$ and the value of R_2 is proportional to $A_{MAX} - A_{MIN}$. Thus the gain of this channel and therefore the gain ratio between the channels can be properly set. In this manner the

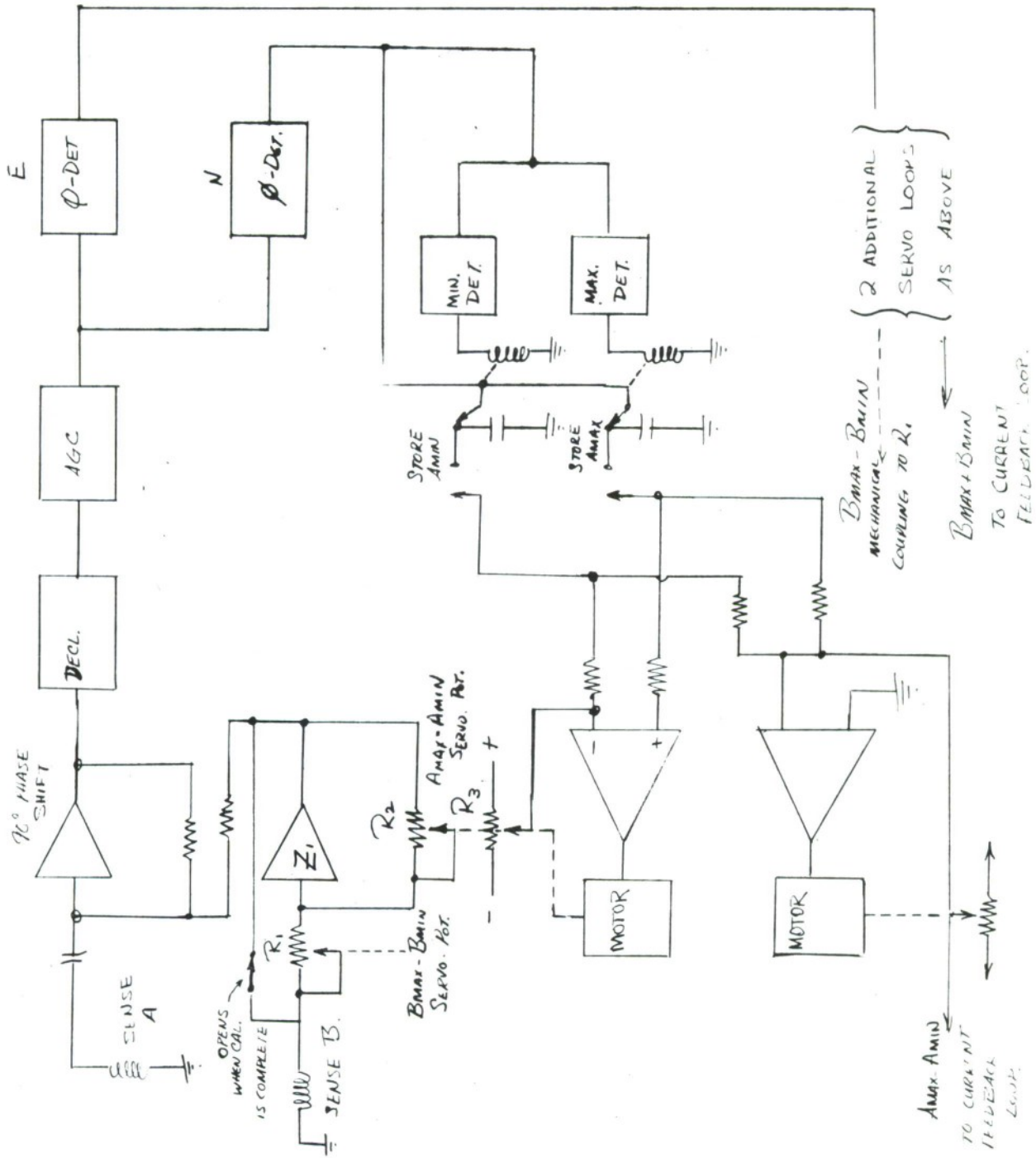

FIGURE 7-3. Automatic Soft Iron Compensation

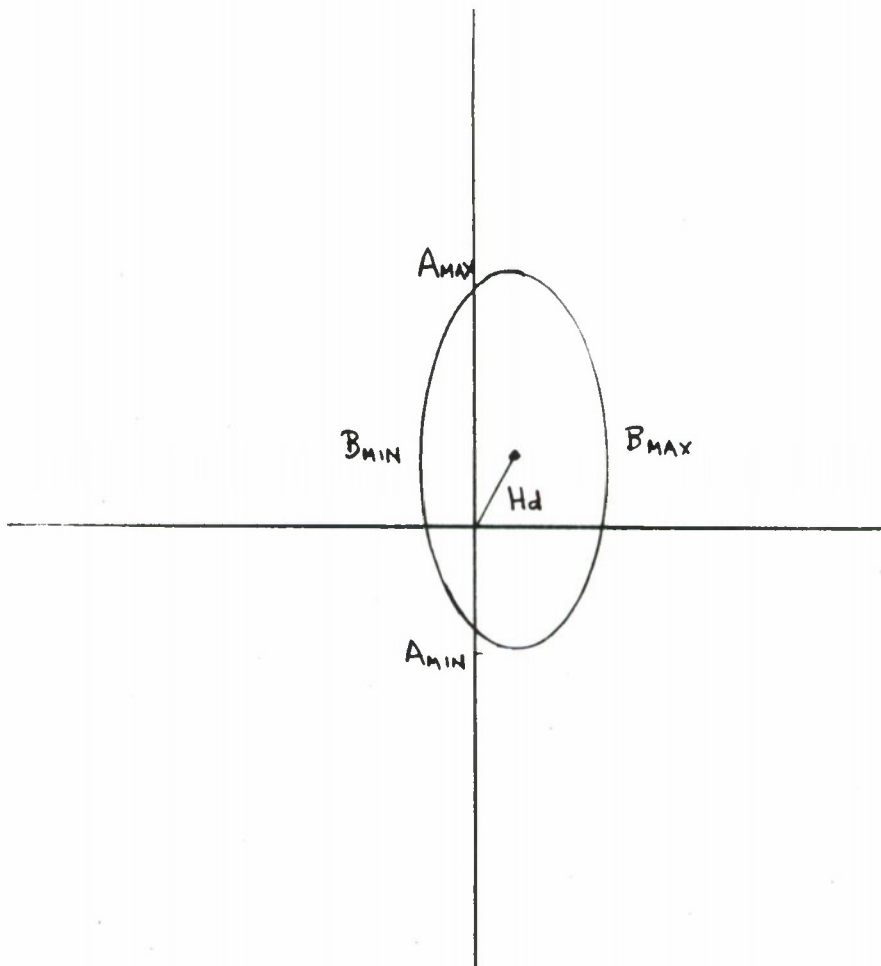

FIGURE 7-4 GENERAL PM DISTURBANCE WITH SOFT IRON



soft-iron disturbance can be automatically calibrated out in the same way the PM disturbances are.

The use of maximum and minimum detectors for PM disturbance calibration also allows the LVN to calibrate out disturbances greater than the earth's field. Thus in Figure 7.5 a disturbance equal to two times the earth's field can also be seen to be equal to the average of the maxima and minima as in equations 7.1 and 7.2. Note that no nulls would occur with a disturbance of this size.

7.3 TANK

The LVN System was mounted on a M-48 tank and measurements were taken to determine the size and type of disturbance. At first the compass was mounted on top of the right rear fender. The compass outputs for the cardinal and intercardinal directions were measured and plotted on a heading circle. See Figure 7.6. The heading circle is very elliptical indicating the presence of large amounts of soft-iron. Also since the major axis is not vertical (i.e. along the N-S axis), the soft-iron is asymmetric to the compass. In addition the center of the ellipse is considerably off center indicating a PM disturbance approximately equal to the earth's field. Additional data was taken with the compass on the left rear fender resulting in approximately the same elliptical heading circle. The major axis of the ellipse was tilted in the opposite direction as the soft-iron was then asymmetric on the other side of the compass. Data was also taken with the compass located on the rear center top and at the rear lower center of the vehicle. This data is shown in Figure 7-7. The major axis of the ellipse for central locations was vertical indicating that the soft-iron is now on axis or symmetrical to the compass. In all cases the tank showed an order of magnitude more soft-iron effect than the jeep and about twice as much PM effects. However the disturbances as shown in Figure 7-7 could be compensated using the scheme proposed for jeeps in the previous section. By locating the compass along the central axis of the vehicle, the soft-iron is on axis and is corrected by the proposed system. In Figure 7-6 the disturbances are off axis and are not corrected by the proposed scheme. However if the compass were oriented so that the major axis of the ellipse is located parallel and perpendicular to the sense windings the disturbance would appear to be on axis and would be compensated out. The declination would however have to be adjusted since the compass would no longer be indicating the vehicle heading which would add complexity to the system and to the operating procedure.

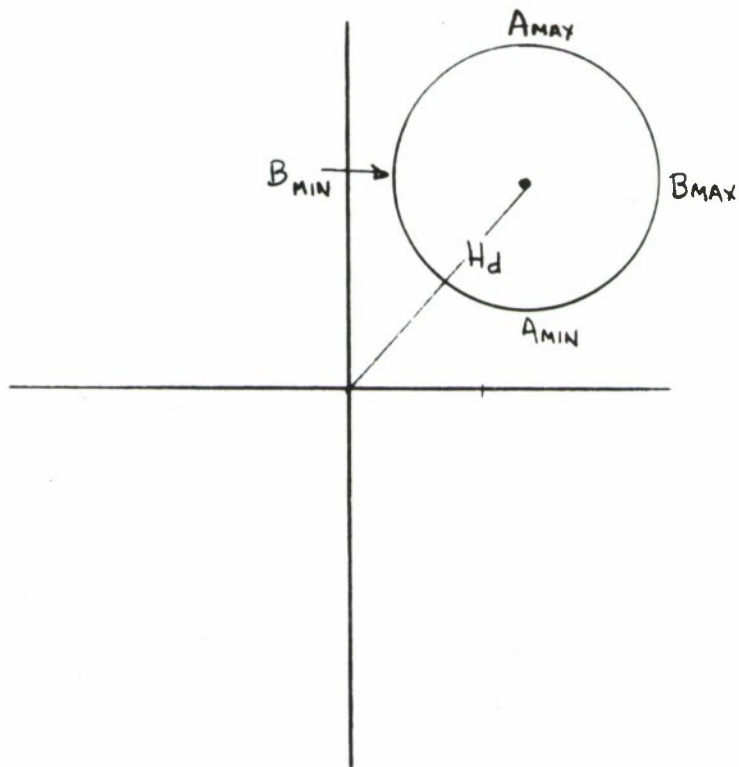

FIGURE 7-5 DISTURBANCE 2X EARTH'S FIELD

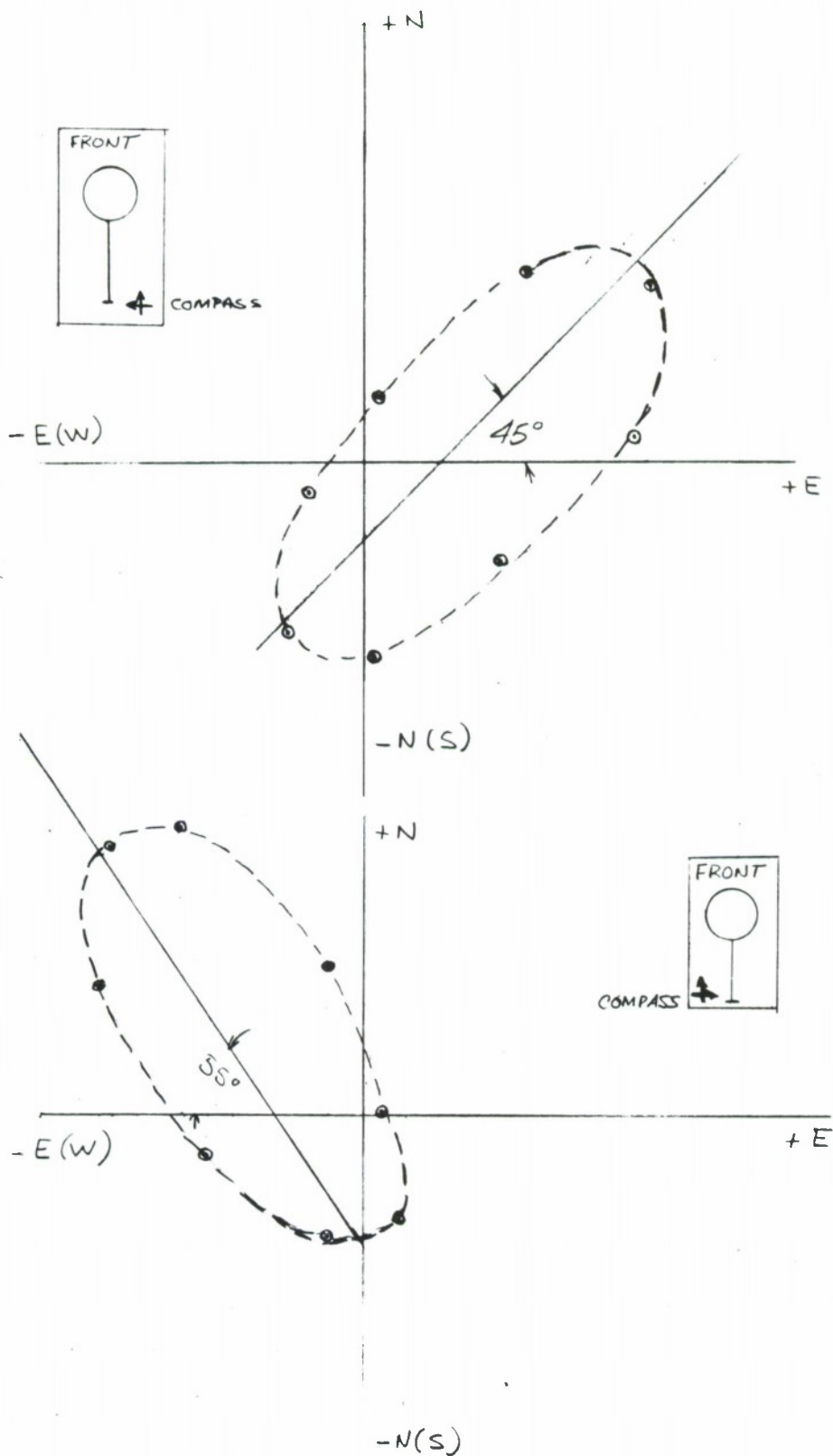

FIGURE 7-6 DISTURBANCES MEASURED ON TANK

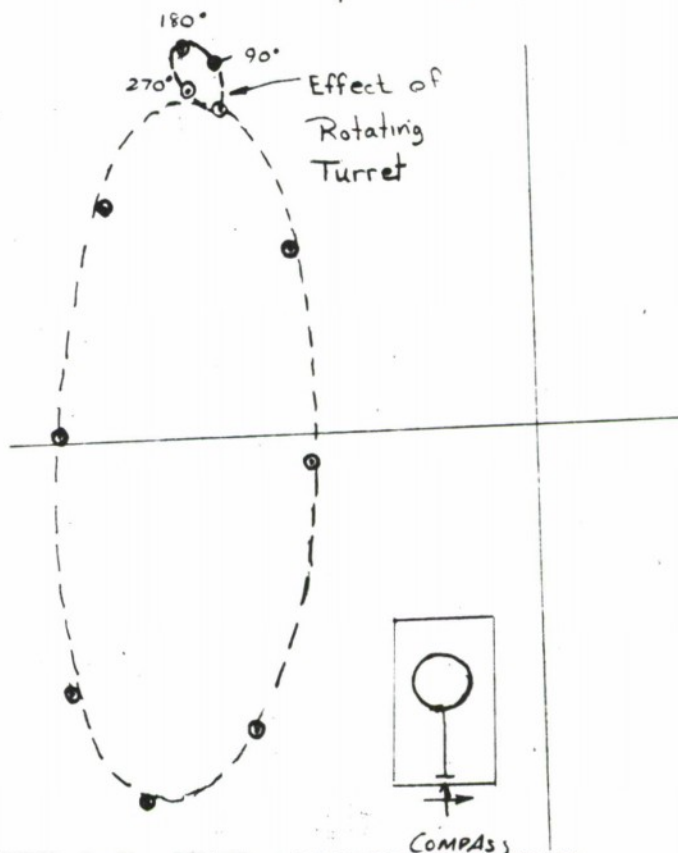
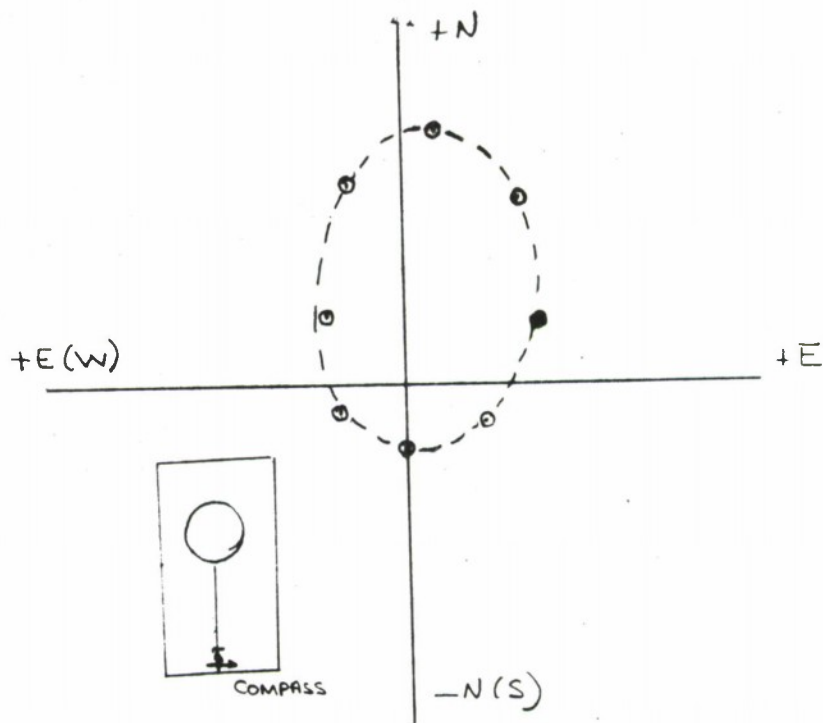

FIGURE 7-7 ~~TYPE~~ DISTURBANCE CONT.



The tank poses an additional problem different from the jeep and APC. A sizeable portion of the vehicle's magnetic disturbance is contributed by the turret. The turret may be rotated while the LVN is in operation changing the magnetic field seen by the compass. Data was taken to observe the effect of rotation of the turret on the compass outputs. The compass was located at the rear lower center of the vehicle with the vehicle headed north. The turret was then rotated 360° and its effect on the heading noted. The results showed a variation in the magnetic field equal to approximately one fifth the earth's field in magnitude. This effect is shown in Figure 7-7. Using the present or the proposed modified system the disturbance is only properly compensated with the turret in the position it held during the calibration. If the turret is moved recalibration is required or system accuracy will deteriorate. In order to devise a method for compensating the compass for turret rotation, more detailed measurements on the magnetic disturbance created are required. Using the system modifications for jeeps proposed in the previous section, operation on tanks appears feasible if the turret is kept in a fixed position. However, with further investigation it appears that techniques can be evolved for automatically compensating for turret rotation.



8.0 CONCLUSIONS AND RECOMMENDATIONS

Two breadboard Vehicle Navigation Systems were developed and tested per the contract requirement. All of the contract requirements and most of the contract goals were met:

1. Magnetic disturbances to heading sensors on APC's, jeeps, and tanks were studied and a method of analysis was evolved wherein the disturbances could be readily identified as to type, placement, and orientation.

2. Techniques of compensation for the disturbances were investigated and a novel means of automatic disturbance compensation was developed.

3. Two breadboard Land Vehicle Navigation (LVN) systems were designed, constructed, and successfully tested. These systems provided navigational accuracy of within 2.5% of the distance travelled when used on APC's.

4. The particular magnetic peculiarities of jeeps and tanks were identified, and a second novel technique for adapting the LVN to those vehicles was proposed.

In light of the above accomplishments, Westinghouse recommends that the LVN development be continued. The breadboard LVN's have already been proven to be more than adequate as a navigational system for APC's. The technique used offers a distinct advantage over any other magnetic system in that, should the magnetic perturbations on the vehicle change for any reason (lightning, shell fire, load shifts, shock, vibration, etc.), recompensation of the disturbances can be quickly accomplished by a field-expedient technique with no additional equipment or directional knowledge required.

In addition, the system, with the modifications proposed herein, could work well on jeeps and tanks offering the possibility of an all-vehicle magnetic navigation system.



The tank poses the most difficult magnetic environment for the LVN due to the larger disturbances present, the greater soft iron, and the movable turret with its inherent disturbance. The proposed LVN modifications would allow operation of the LVN with the turret fixed, and it is believed that, with more investigation, an operational system without restrictions on turret movement could be evolved. If the LVN can be adapted to tanks, a considerable long-run logistical cost savings could be realized since, up-to-the present, only the more expensive gyroscopic techniques have been used successfully on tanks. The magnetic approach would offer a simpler, cheaper, and more-rugged alternative.

From this view, Westinghouse recommends that the jeep and tank modifications proposed herein be further pursued to determine the feasibility of an inexpensive all-vehicle magnetic navigation system.



APPENDIX

TANK COMPENSATION ANALYSIS AND
DESIGN PLAN



DATA ANALYSIS

As described in Section 2.1 disturbances caused by soft iron tend to distort the heading circle into an ellipse. As was stated all symmetrical soft iron disturbances can be equated to a single horizontal disturbance plus a vertical soft iron disturbance. In order to further analyze the magnetic disturbances on an M60 tank it is necessary to further consider the effects of asymmetrical soft iron so that their effect on the measured data can be recognized. Figures A-1 and A-2 show the effect of asymmetrical soft iron. When the vehicle is aligned with the earth's field the intensification of the field is caused by magnetization of the soft iron as with horizontal symmetrical soft iron; however when the iron is off-axis with respect to the compass a rotational error is introduced. The magnitude of this rotational error is greatest when the earth's field is aligned with the soft iron and at a minimum when the earth's field is perpendicular to the soft iron. The net result is that the North/South axis is rotated more than the East/West axis and thus they are no longer perpendicular.

Vertical soft iron as explained in Section 2.1, is equivalent to a PM disturbance in that it becomes magnetized from top to bottom by the vertical component of the earth's field independent of heading. Soft iron which is oblique (at some angle between vertical and horizontal) acts as a PM disturbance in that it is always magnetized in the same direction. However, since the earth's field at this latitude is about 70° from horizontal, oblique soft iron becomes more strongly magnetized when its axis is most nearly aligned with the earth's field. See Figure A-3. The effect of oblique soft iron is to cause the North/South and East/West axes to no longer bisect each other; the resulting heading circle is no longer elliptical.

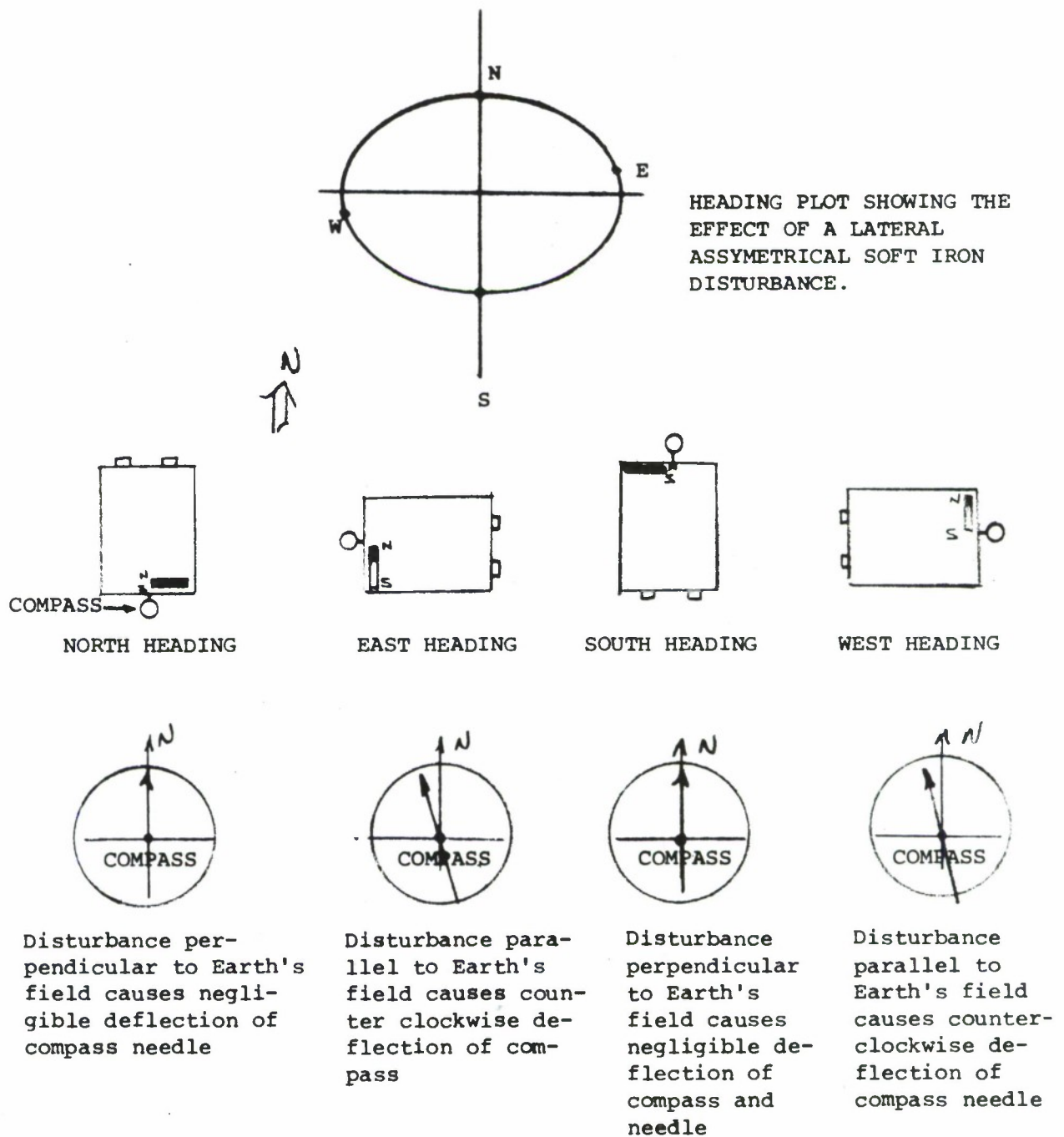
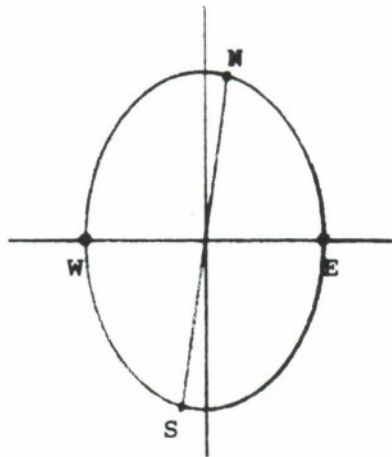

FIGURE A-1. Lateral Assymetrical Soft Iron



HEADING PLOT SHOWING THE EFFECT OF LONGITUDINAL ASSYMETRICAL SOFT IRON DISTURBANCE



NORTH HEADING

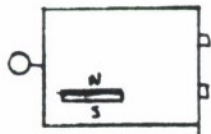

EAST HEADING

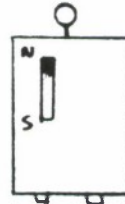

SOUTH HEADING

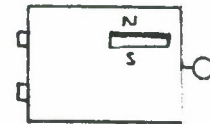

WEST HEADING



Disturbance parallel to earth's field causes clockwise deflection of compass needle



Disturbance perpendicular to earth's field causes negligible deflection of compass needle



Disturbance parallel to earth's field causes clockwise deflection of compass needle



Disturbance perpendicular to earth's field causes negligible deflection of compass needle

FIGURE A-2. Longitudinal Assymetrical Soft Iron

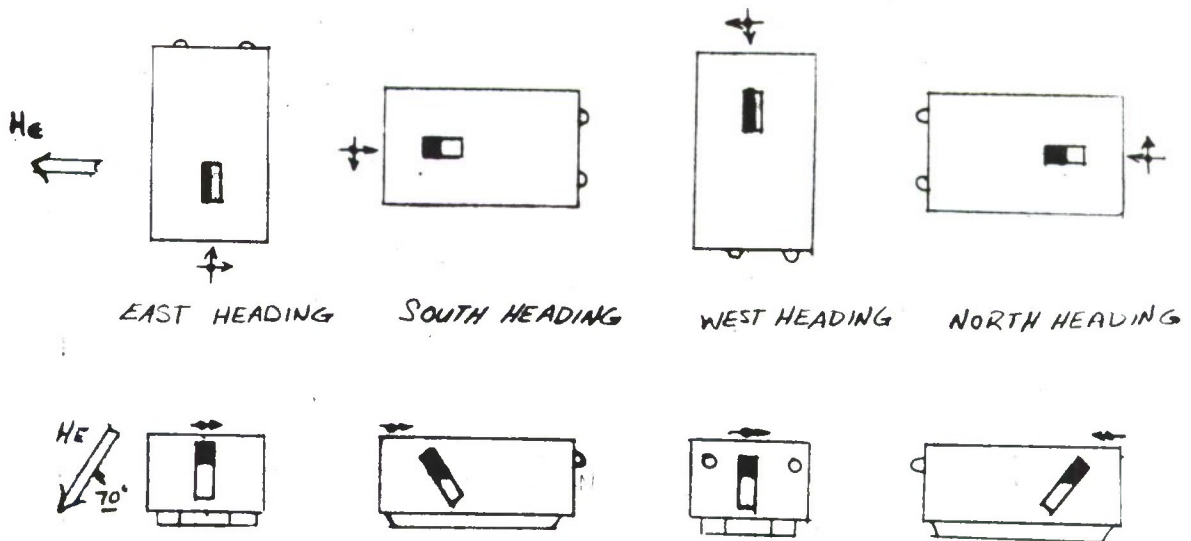
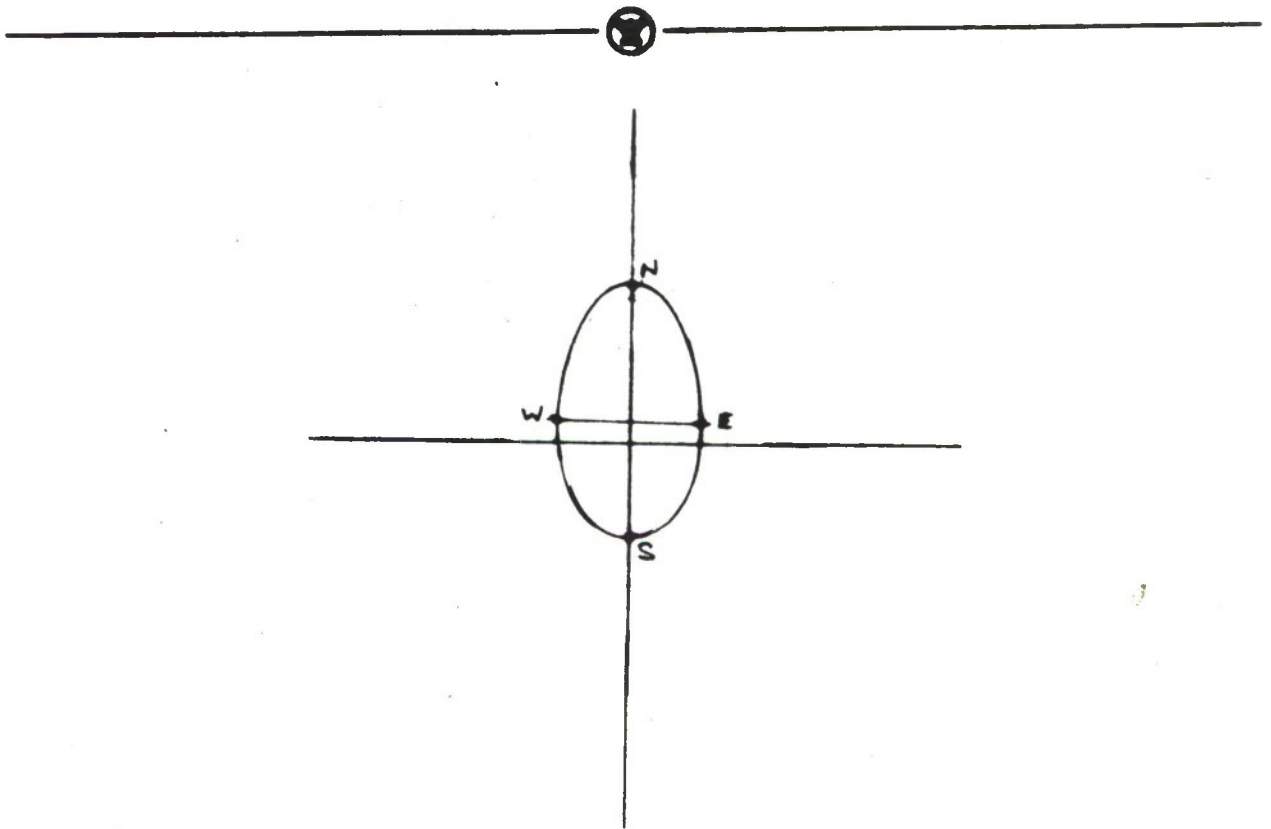

FIGURE A-3. Oblique Soft Iron

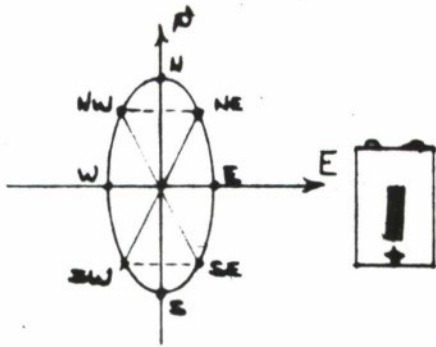

Figure A-4 shows a summary of the effects of various types of soft iron. The simplest form of soft iron compensation is to change the gain ratio between the sense winding from unity to a value which forces the ellipse into a circle again. If the minimum and maximum voltage in the north coil (N_{MIN} and N_{MAX}) and the east coil (E_{min} and E_{max}) are measured, the gain ratio (G) required may be computed as follows

$$(1) \quad G = \frac{N_{MAX} - N_{MIN}}{E_{MAX} - E_{MIN}}$$

If the north channel output is multiplied by $1/G$ for various types of soft iron effects, the following results:

1. Longitudinal, horizontal symmetrical soft iron:
(Figure A-5a) When the ratio correction is applied complete correction of the soft iron error is accomplished.
2. Lateral, horizontal, symmetrical soft iron:
(Figure A-5b) Application of the ratio correction results in complete compensation of the soft iron error present.
3. Horizontal, assymetrical, on axis, soft iron:
(Figure A-5c) Since the quantities $N_{MAX} - N_{MIN}$ and $E_{MAX} - E_{MIN}$ are no longer the major and minor axes of the ellipse the gain correction computed by equation (1) above does not force the heading plot to be circular. While the errors are in general decreased complete compensation of the soft iron error does not result.
4. Lateral, horizontal off axis soft iron:
(Figure A-5d) Application of the gain ratio correction forces the heading plot to be circular but the rotation of the E/W axis with respect to the N/S axis is not compensated for and uncorrected errors are still present.
5. Longitudinal horizontal off axis soft iron:
(Figure A-5e) Again the heading plot is circular but rotation of the N/S axis with respect to the E/W axis is not compensated.



(a) LONGITUDINAL, HORIZONTAL, SYMMETRICAL

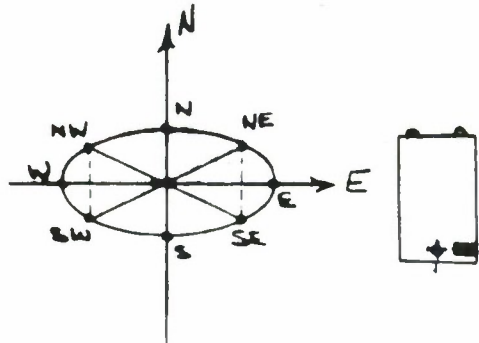

(b) LATERAL, HORIZONTAL, SYMMETRICAL

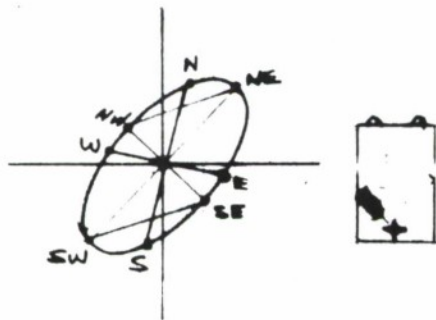

(c) HORIZONTAL, ASSYMETRICAL, ON AXIS

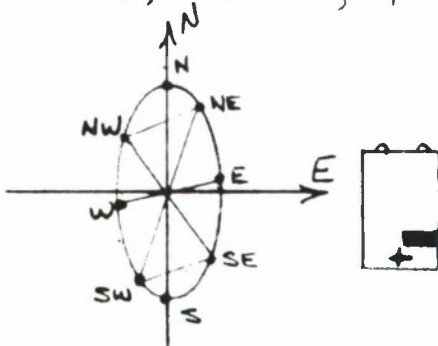

(d) LATERAL, HORIZONTAL, OFF-AXIS

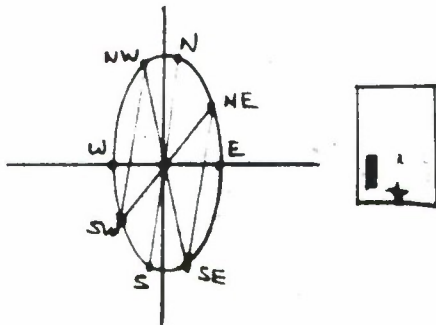

(e) LONGITUDINAL, HORIZONTAL, OFF AXIS

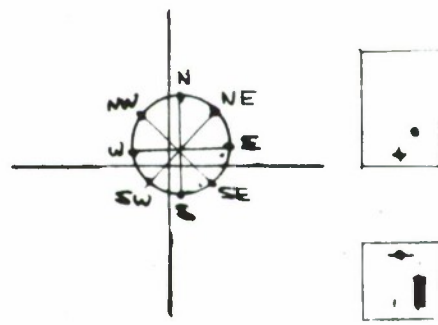

(f) VERTICAL ASSYMETRICAL

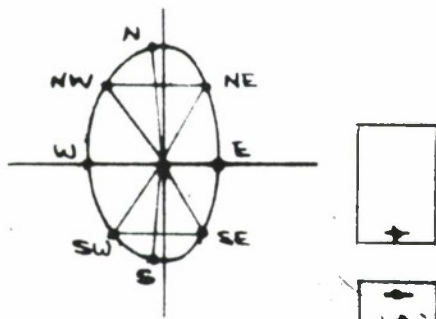

(g) LONGITUDINAL OBLIQUE

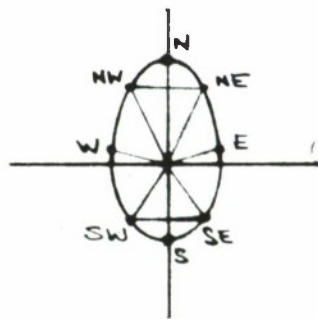

(h) LATERAL OBLIQUE

BACK

FIGURE A-4. Summary of Various Soft Iron Effects

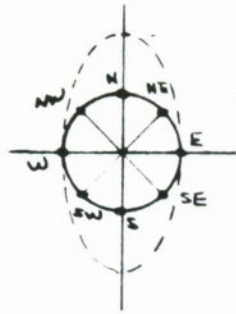

(a) LONGITUDINAL, HORIZONTAL, SYMMETRICAL

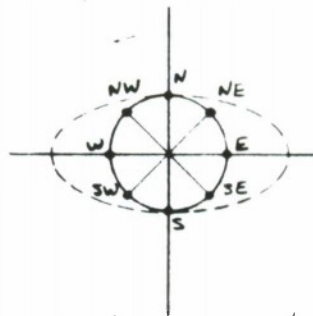

(b) LATERAL, HORIZONTAL, SYMM.

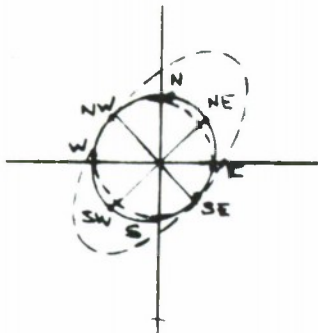

(c) HORIZONTAL, ASSYMETRICAL, ON AXIS

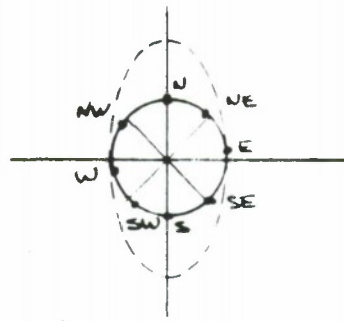

(d) LATERAL, HORIZONTAL, OFF AXIS

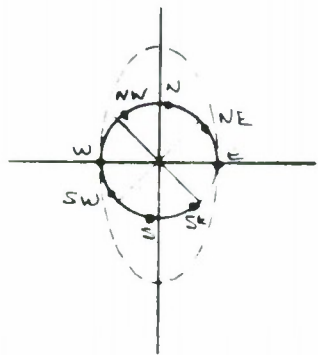

(e) LONGITUDINAL, HORIZONTAL, OFF-AXIS.

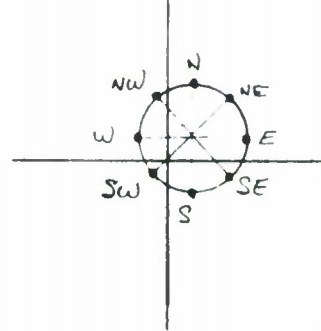

(f) VERTICAL, ASSYMETRICAL.

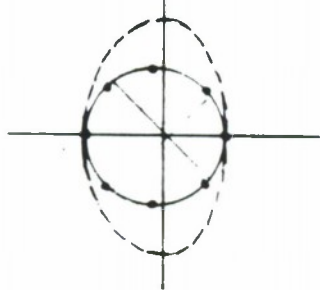

(g) LONGITUDINAL, OBLIQUE

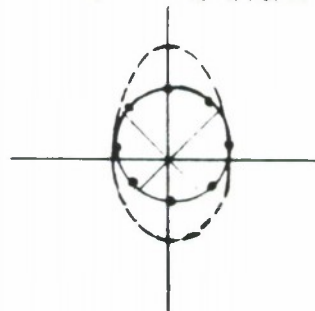

(h) LATERAL OBLIQUE

FIGURE A-5. Effects of Gain Ratio Correction



6. Vertical assymetrical soft iron off axis:

(Figure A-5f) Since the heading plot is already circular no change results from the ratio correction. However vertical soft iron is not distinguishable from a PM disturbance and is compensated for by the PM compensation.

7 & 8. Oblique soft iron:

(Figure A-5g) Since the heading plot is not elliptical a ratio correction reduces but does not completely compensate for the error.

It can be seen that in order for a system using translation and a E/W to N/S ratio correction to work properly the location of the compass is restricted to a position where the center of the soft iron present is symmetrical to the compass.

In order to implement a system, measurements of the magnetic disturbance at various locations on an M60 tank were required. Measurements were made using the breadboard vehicle navigator developed on this contract. The AGC and PM compensation were disabled so that the east and west outputs were indicative of both the magnitude and direction of the magnetic field at the sensor locations. Data was taken for each sensor location with the vehicle headed in each of the cardinal and intercardinal directions. In addition the turret was rotated in 45° increments and data taken to indicate the effect of turret rotation on the magnetic field at the sensor. Figure A-6 shows the locations on the tank where data was taken: Position 1, right rear fender; Position 2, left rear fender; Position 3, rear top center; Position 4, left front fender; Position 5, rear bottom center.

Heading plots (Figure A-7) made at all positions show permanent magnetic disturbances up to two times the earth's field in magnitude. Positions 1, 2, and 4 show large amounts of assymetrical soft iron. This is to be expected since the sensor is located far from the center of the vehicle. Positions 3 and 5 being located on the longitudinal axis of the vehicle

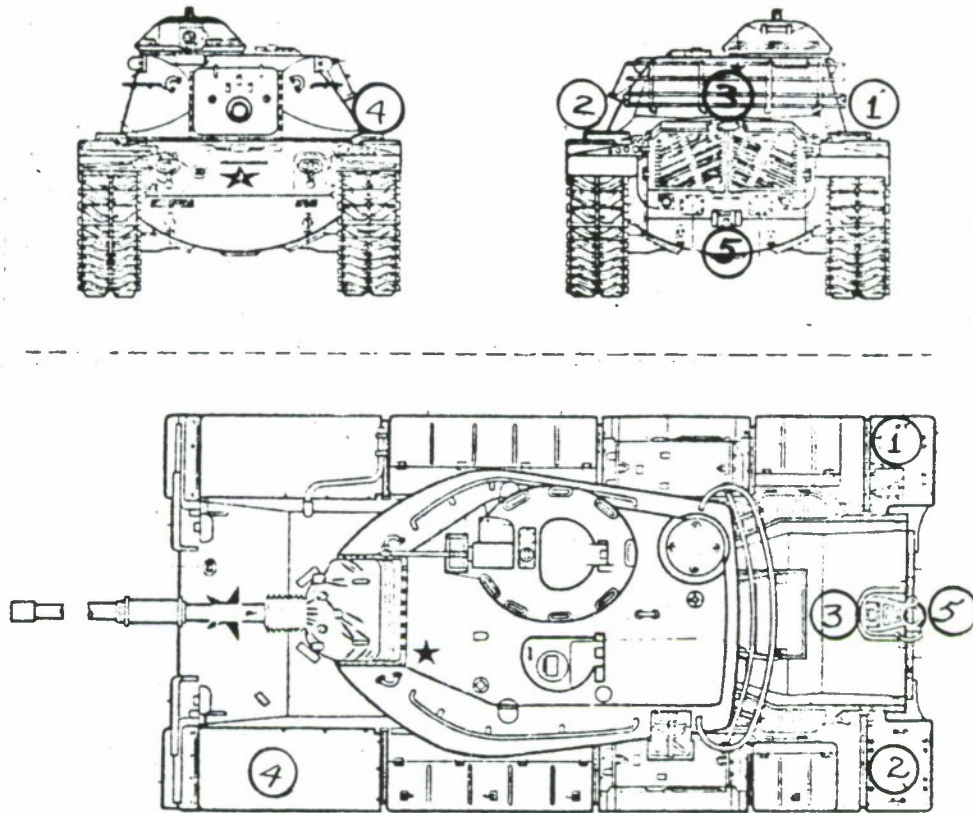
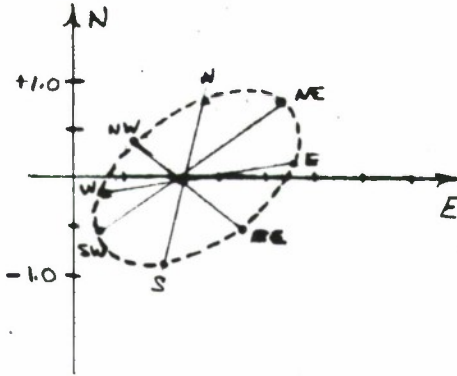
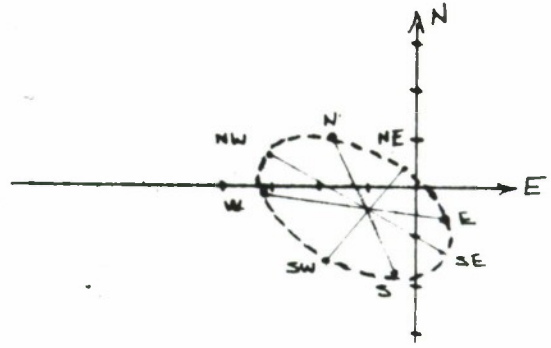

FIGURE A-6. Sensor Locations for M60 Tank Measurement



(a)
POSITION 1: RT. REAR FENDER



(b)
POSITION 2: LEFT REAR FENDER

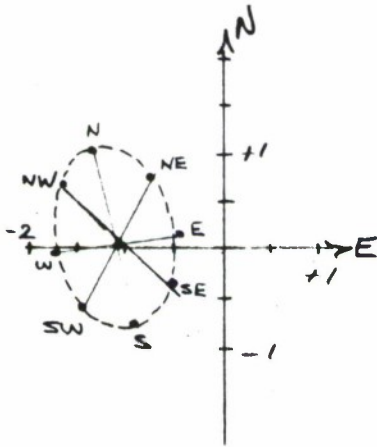

(c)
POSITION 3: REAR CENTER TOP

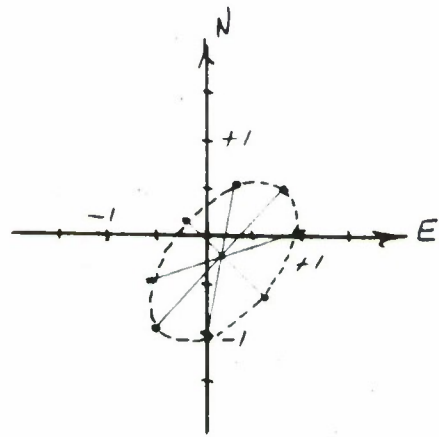

(d)
POSITION 4: LEFT FRONT FENDER

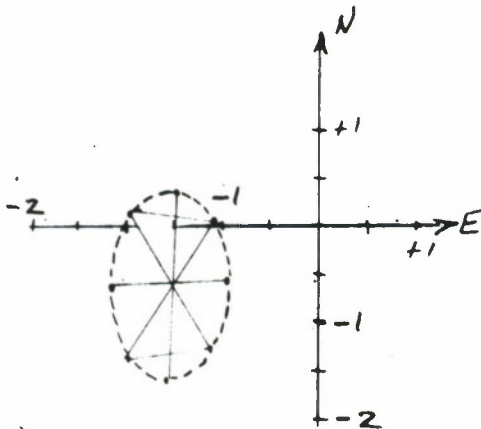

(e)
POSITION 5: REAR CENTER BOTTOM.

FIGURE A-7. Heading Plots
Using Data Taken on M-GOAL Tank



showed less assymetrical soft iron disturbance. Horizontal off axis (N/S & E/W axes not 90° apart) and oblique (N/S and E/W axis not bisecting one another) were also evident.

Since the most symmetrical ellipse was obtained at position 5, data was taken as the sensor was varied about position 5. Figure A-8a shows a heading plot of the most nearly symmetrical ellipse obtained. The presence of some oblique soft iron disturbance can still be noted. The compensation method described in Section 7 of this report was mathematically applied to this data. The compensation method involves translation of the heading plot centering it over the origin for PM correction; and a gain ratio correction to account for symmetrical on axis soft iron. Figure A-8b shows the result of applying this correction to the data. Note that the remaining heading errors are as large as 13.1° . These errors are caused by nonsymmetrical off axis soft iron effects still present. The area where the soft iron effects appear to be perfectly symmetrical is quite small and would vary from tank to tank as the permeability of the iron itself would vary from vehicle to vehicle. A system which imposes such tight restrictions on sensor location is not desirable especially when this location may vary for different tanks.

At this point it is desirable to make a detailed study of the errors which remain after the PM compensation and the gain ratio correction have been made. A plot of the error for each sense coil as a function of heading is shown in Figure A-9. The errors are sinusoidal in nature and can be represented using a Fourier series. The error in the east sense coil (E_E) can be represented by $E_E = A_0 + A_1 \sin \theta + B_1 \cos \theta + A_2 \sin 2\theta + B_2 \cos 2\theta$. Similarly the North coil error (E_N) can be represented by $E_N = C_0 + C_1 \sin \theta + D_1 \cos \theta + C_2 \sin 2\theta + D_2 \cos 2\theta$.

a) Heading plot

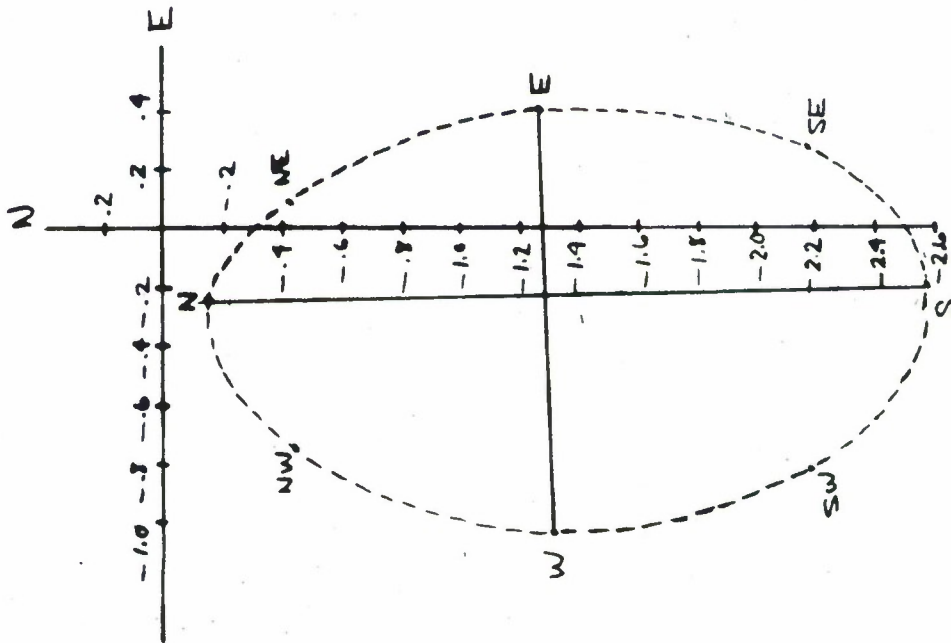

b) corrected heading plot.

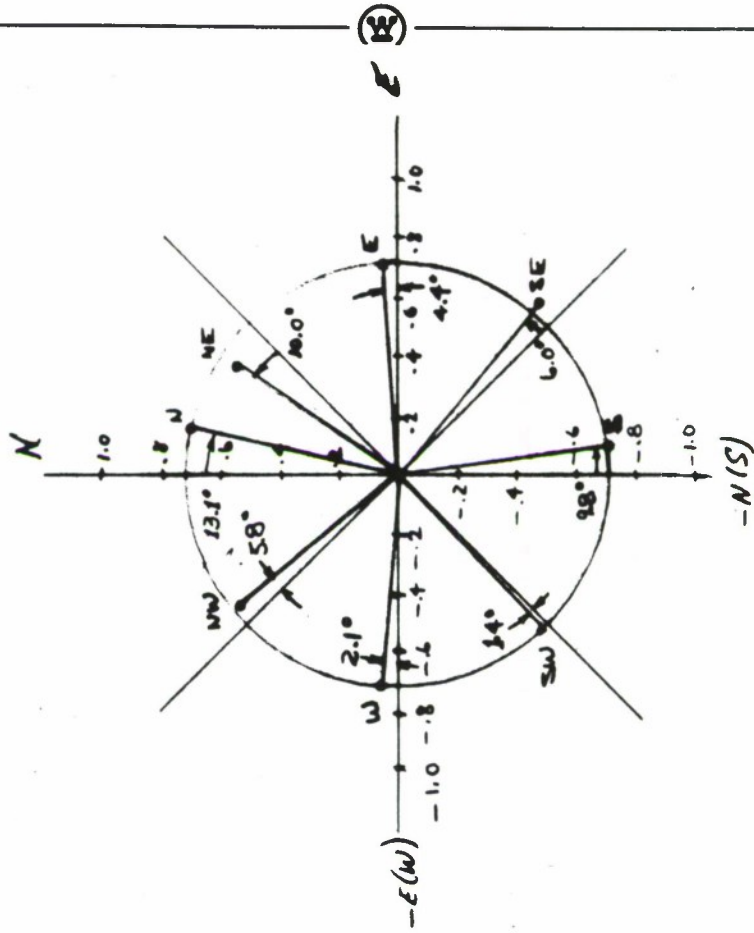
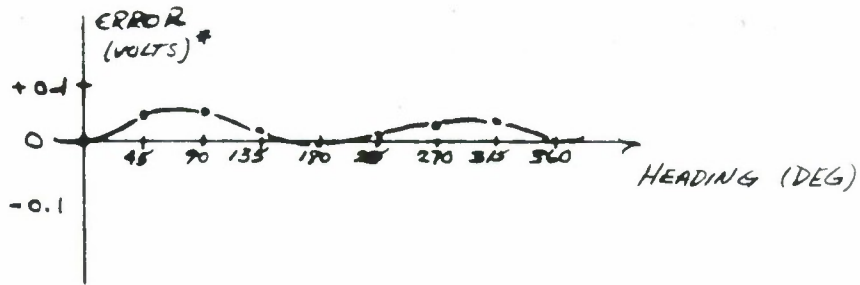
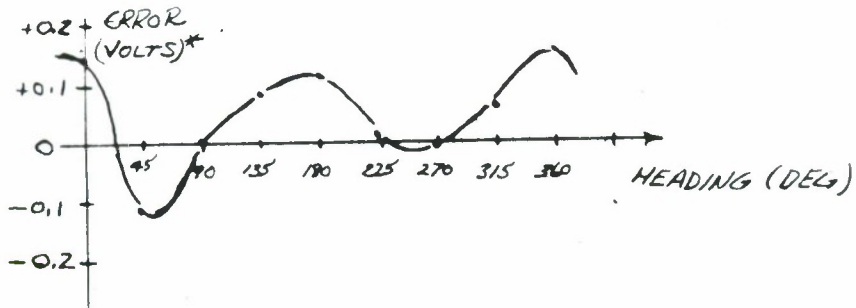

FIGURE A-8 M60A1 TANK DATA

FIGURE A-8. M60A1 Tank Data



NORTH COIL ERROR VS. HEADING



EAST COIL ERROR VS. HEADING.

- * The earth's field causes a voltage of 0.710 volts
- Each 12.4 mV of error corresponds to 1° error.

FIGURE A-9. M60A1 Tank: Plot of Error Residual After Initial Correction



Evaluation of the constants A_n and B_n for the east coil results in an expression of the east coil error as follows:

$$E_E = 0.338 = 0.0104 \cos \theta - 0.0142 \sin \theta + \\ 0.070 \cos 2\theta - .068 \sin 2\theta$$

similarly

$$E_N = 0.0263 + 0.006 \cos \theta + .0114 \sin \theta - 0.020 \\ \cos 2\theta + .0028 \sin 2\theta$$

Each of these expressions consists of a sizeable dc term (A_0 and C_0). These errors are caused by uncompensated PM disturbances. Accurate PM compensation is not obtained due to the distortion of the ellipse resulting in improper measurement of the amount of translation from the origin present in the heading plot. These terms could be compensated by an iterative calibration process whereby the vehicle is recalibrated with the first calibration in effect.

The sinusoidal terms however present a severe problem. The magnitude of the correction required is dependent upon heading. Thus the correction cannot be computed without already knowing the heading.

Therefore in order to implement a navigation system on a tank it is necessary to accurately know the vehicle heading at least during calibration. A system using a directional gyroscope during calibration is proposed later in this appendix.

TURRET DISTURBANCE

In addition to the above, the tank poses an additional problem in that the magnetic signature of the vehicle varies significantly as the turret is rotated. The turret, like the vehicle itself, creates a disturbance made up of a PM and soft iron component. As the turret is rotated the orientation of

of this disturbance with respect to the sensor changes. In general the center of the disturbance is not the center of rotation of the turret. Therefore the distance from the sensor to the turret disturbance varies in addition to the orientation. The resulting errors as a function of turret position vary in a very complex manner.

Data was taken for eight different turret positions at all cardinal and intercardinal vehicle headings. Figure A-10 shows the effect of turret rotation at five different compass locations. Note that for four of the five compass locations the elliptic heading plot was translated while the shape and orientation remain fixed. At position 4 the shape of the ellipse was significantly affected by turret rotation. Pure translation of the ellipse is caused by the permanent magnetism of the turret. This is because the disturbance due to a permanent magnet is independent of vehicle heading, and causes the same change at every point on the heading circle as indicated by the arrows in Figure A-10c. Soft iron effects from the turret are dependent upon the position of the turret with respect to both the earth's field (heading) and the vehicle. Therefore changes in orientation and aspect ratio of the ellipse occur. From Figure A-10 it can be seen that both PM and soft iron effects are present. With the compass located at the extreme rear of the vehicle, sufficient distance between the compass and the turret are maintained to make the soft iron effect from the turret negligible. Thus with the compass located at the rear of the vehicle a turret calibration system which monitors the turret position and applies a corresponding PM correction to the sensor should provide adequate performance.

PROPOSED SOLUTION

General Description

A block diagram of the compass calibrator for use with vehicles such as the M60 battle tank is shown by Figure A-11. The extended method requires four separate and distinct types

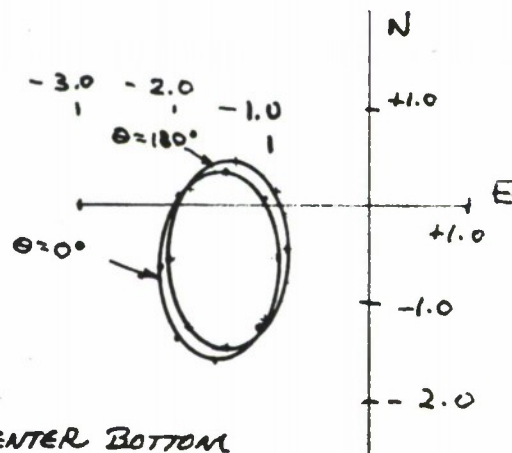
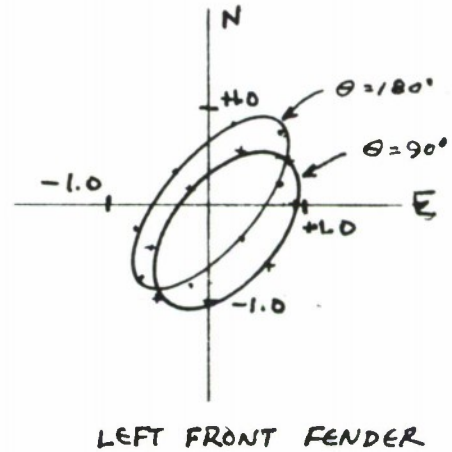
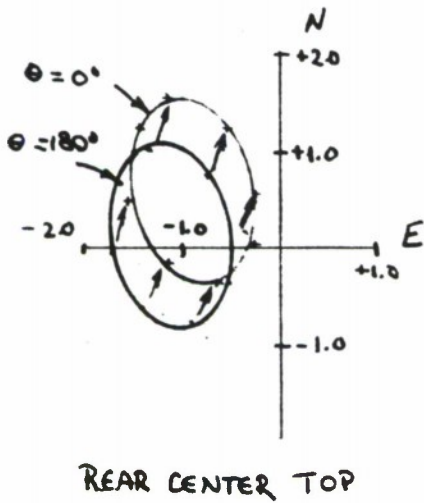
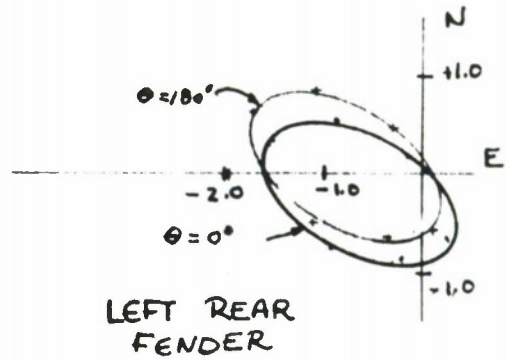
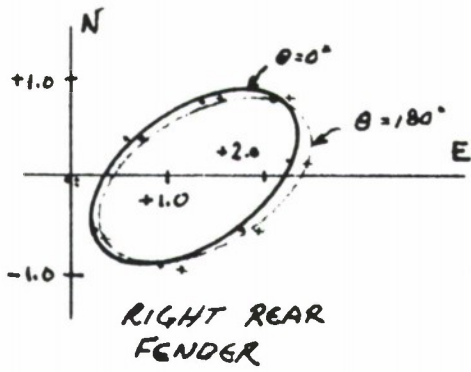

FIGURE A-10. M60A1 Data Taken at Several Locations

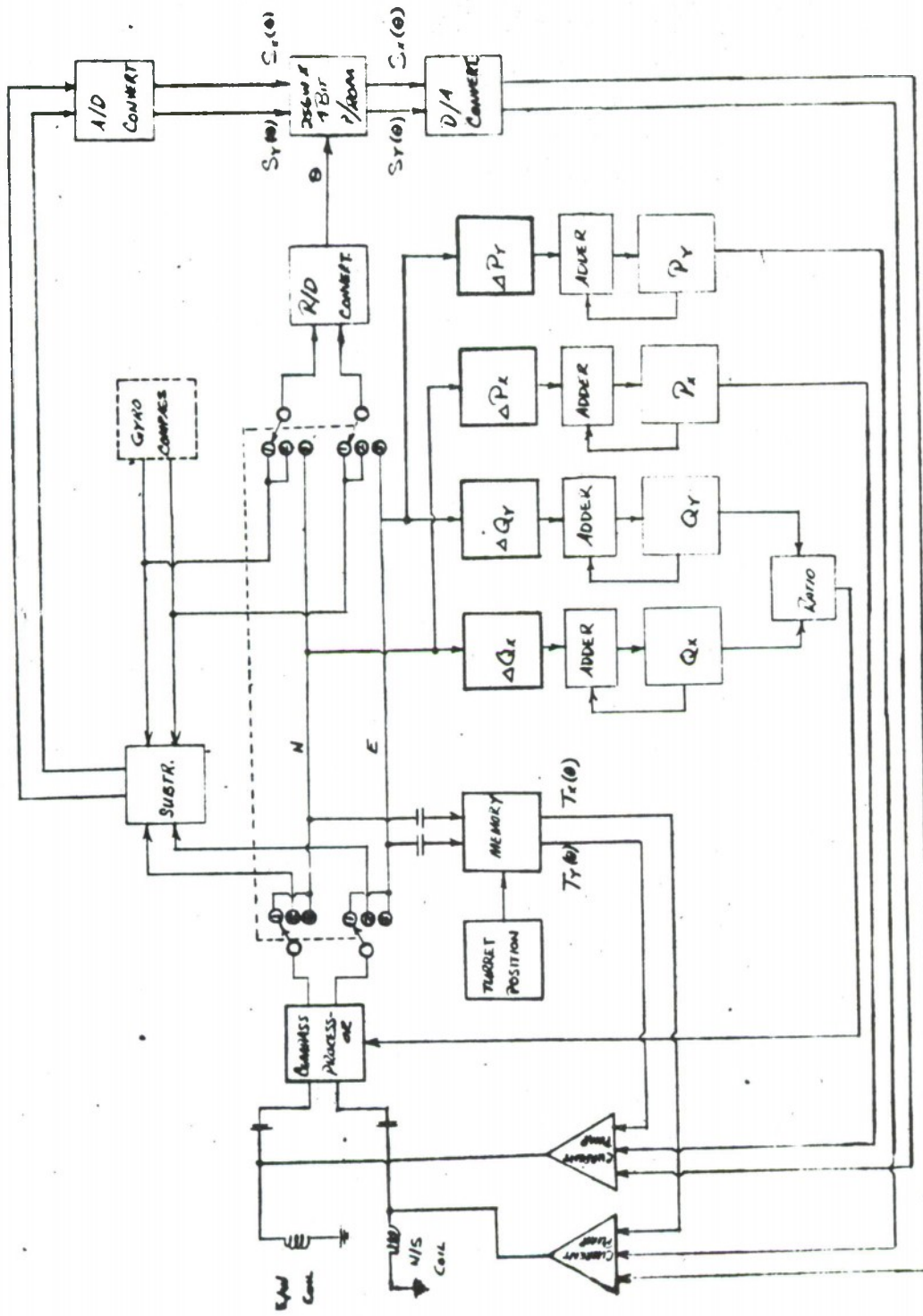

FIGURE A-11. Proposed System Block Diagram

RTV

of correction which are to be applied in a specific order. The necessary corrections are derived by slowly driving the vehicle in a full circle and slowly rotating the turret through 360 degrees with the vehicle stationary. In the first stage of calibration (vehicle driven in a full circle) the corrections for permanent magnetism and for symmetrical soft iron are derived, stored, and thereafter applied to the flux gate compass. This centers the heading "circle" and minimizes ellipticity. In the second stage of calibration (vehicle again driven in a full circle) the corrected headings are now compared against a directional standard such as a "short term" gyro compass and the errors are stored using the gyro heading as an address. When these errors are properly read from the memory the effects of assymetrical soft iron are corrected. In the final stage of calibration the turret is rotated with the vehicle stationary. In this correction the address to the fine correction memory is frozen while the change in location of the heading circle is stored using the turret angle as a memory address. This final correction compensates permanent magnetism in the turret structure. The placement of the flux gate compass on the vehicle minimizes the turret error which furthermore is predominantly caused by permanent magnetism. Recalibration of the compass to accommodate changes in permanent magnetism can be accomplished without repeating the fine calibration. Consequently the gyro reference is not needed for this operation.

Detailed Description

Some details of the calibration procedure are demonstrated by the system diagram (Figure A-11). With switches S1 and S2 in the top position the compass processor outputs are applied to circuitry which stores the maximum and minimum outputs obtained during the first circle executed by the vehicle. Computation



of the translational corrections (P_X and P_Y) from these stored results is done as follows;

$$\Delta P_X = \frac{N_{MAX} + N_{MIN}}{2}$$

$$\Delta P_Y = \frac{E_{MAX} + E_{MIN}}{2}$$

and the computation of the elliptical corrections from the stored results is done as follows;

$$\Delta Q_X = (N_{MAX} - N_{MIN})$$

$$\Delta Q_Y = (E_{MAX} - E_{MIN})$$

The full elliptical correction (Q_X/Q_Y) is then computed from the accumulated Q's. When these two corrections are arithmetically applied to typical raw tank data the result is a residual maximum error somewhat over 10 degrees, chiefly an intercardinal error. With the heading circle now approximately circular another level of accuracy is obtained by a fine calibration.

In the fine calibration mode the vehicle is again driven in a circle. In this mode (S1 and S2 in center position) the compass processor outputs are subtracted from those of a calibrated gyro compass. The differences $S_X(\theta)$ and $S_Y(\theta)$ are stored in a memory using the gyro compass output (θ) as an address. In the operational mode (S1 and S2 in the bottom position) $S_X(\theta)$ and $S_Y(\theta)$ provide the fine corrections to the compass. In both calibrate and operate modes a resolver to digital converter is required to generate an unambiguous address to the memory.

For the last stage of calibration (vehicle remains stationary), the fine correction address is frozen, and the turret is rotated through 360° . In this case, only the change in the north and east sense winding outputs are stored, using the turret position for an address. These quantities $T_X(\theta)$ and $T_Y(\theta)$ respectively are used to compensate the effect of turret permanent magnetism.

The calibration measurements are direct and are limited in accuracy by the precision of the technique involved. During operation the address for the fine correction is taken from the flux gate compass. As this heading is in error the correction chosen will be in error also. However when this correction is applied to the compass a new heading results which in turn selects a more accurate correction. In this manner the system converges toward the correct heading and correction address.

Limitations of this process have been studied by means of computer simulation. The program for this simulation is given by Figure A-12. The program operates by simulation of the residual errors remaining after the first stage of calibration and by simulation of an ideal memory in which the errors are addressed by the true heading. The simulated errors in the program (statements 125 through 210) were obtained by Fourier analysis of the heading errors following arithmetic corrections for permanent magnetism and ellipticity of the heading circle. The complete north and east coil signals are simulated in statements 300 and 310. The DC corrections to be applied to the sense coils are simulated in statements 400 and 410. Statements 360 and 370 provide the corrected sense winding outputs. The initial heading angle θ_2 is computed in statements 320 through 340 and the final heading angle θ_0 is computed in statements 380 through 395 after 10 iterations ($K = 10$ in statement 350). In operation the program addresses the stored corrections S_2 and R_2 by means of θ_0 which has an initial value equal to θ_2 but a final value equal to the true heading θ .



```
100 PRINT "COMPASS CORRECTION"
110 LET H=.705
120 LET P1=3.14159
125 LET A1=.0263
130 LET B1=.0114
140 LET C1=.006
150 LET D1=.0028
160 LET X1=-.020
170 LET F1=.0388
180 LET G1=-.0142
190 LET H1=-.0104
200 LET I1=-.068
210 LET J1=.070
220 PRINT "θ", "θ2", "θ0"
240 LET S2=0
250 LET R2=0
260 FOR θ1=0 TO 360 STEP 5
270 LET θ=θ1*P1/180
280 LET S1=A1+B1*SIN(θ)+C1*COS(θ)+D1*SIN(2*θ)+X1*COS(2*θ)
290 LET R1=F1+G1*SIN(θ)+H1*COS(θ)+I1*SIN(2*θ)+J1*COS(2*θ)
300 LET N1=H*COS(θ)+S1
310 LET E1=H*SIN(θ)+R1
320 LET θ2=ATN(E1/N1)
330 IF N>0 THEN 350
340 LET θ2=ATN(E1/N1)+P1
350 FOR K=1 TO 10 STEP 1
360 LET N=H*COS(θ)+S1-S2
370 LET E=H*SIN(θ)+R1-R2
380 LET θ0=ATN(E/N)
390 IF N>0 THEN 400
395 LET θ0=ATN(E/N)+P1
400 LET S2=A1+B1*SIN(θ0)+C1*COS(θ0)+D1*SIN(2*θ0)+X1*COS(2*θ0)
410 LET R2=F1+G1*SIN(θ0)+H1*COS(θ0)+I1*SIN(2*θ0)+J1*COS(2*θ0)
430 NEXT K
435 PRINT θ*180/P1, θ2*180/P1, θ0*180/P1
440 NEXT θ1
450 END
```

FIGURE A-12. Computer Program Used to Simulate Proposed System



The computed results are given in Figure A-13. For the magnitude of errors observed on this particular vehicle the method is seen to converge at all headings with virtually no error after 10 iterations. In a subsequent calculation all error components were doubled and in that case after 10 iterations the worst case error was only .01 degrees. The initial error now was 19.8 degrees. The results confirmed speculations that the ultimate limit was 45 degrees for errors in θ and 22.5 degrees for errors in 2θ .

In practice the accuracy will be limited by the memory resolution. A resolution of 1.4 degrees (2×256 words) should keep the quantization error well below 1° .

CONCLUSIONS

Based on the data analysis of this program it has been shown that a magnetic compass navigation system for use on an M60 battle tank is feasible. It has been shown that in general the magnetic disturbance is composed of a permanent magnetic and a soft iron component. Soft iron disturbances can be further classified as Symmetrical and Assymetrical. Three vehicles (M113 APC, M151 jeep and M60 tank) have been evaluated and their magnetic properties studied with the following results:

1. M113 APC - With the compass located at top rear center of the vehicle the magnetic disturbance is essentially a PM disturbance which can be easily compensated automatically. This has been verified by road testing during this program.

2. M151 Jeep - With the compass located at the rear center of the vehicle the magnetic disturbance is chiefly PM with a small but significant amount of symmetrical soft iron. The disturbances can be compensated using the PM correcting system developed for use on the APC which results in a navigational error of about 4%. Additional accuracy, better than 2%, can be obtained by applying a N/S to E/W ratio correction. Using this system the calibration procedure is still automatic and system complexity is not substantially increased.

0	COMPASS CORRECTION	60			
0	187.811	8.16967E-6	179.399	180.	180.
5	11.502		176.245	185.	185.
10	15.9466		182.344	190.	190.
15	18.4939		188.648	195.	195.
20	21.8943		195.092	200.	200.
25	25.2984		201.596	205.	205.
30	28.7565		208.075	210.	210.
35	32.3176		214.45	215.	215.
40	36.0279		220.656	220.	220.
45	39.9298		226.651	225.	225.
50	44.0587		232.413	230.	230.
55	48.4404		237.941	235.	235.
60	53.0874		243.253	240.	240.
65	57.9952		248.378	245.	245.
70	63.1402		253.358	250.	250.
75	68.4788		258.237	255.	255.
80	73.9502		263.065	260.	260.
85	79.4825		267.892	265.	265.
90	85.0006		92.7671	270.	270.
95	-69.5644		97.7376	-85.0003	-85.0003
100	95.7323		-77.1562	-80.0003	-80.0003
105	100.854		-71.8818	-75.0003	-75.0003
110	105.782		-66.4197	-70.0003	-70.0003
115	110.519		-60.7666	-65.0003	-65.0003
120	115.079		-54.9394	-60.0003	-60.0003
125	119.492		-48.9767	-55.0003	-55.0003
130	123.792		-42.9376	-50.0003	-50.0003
135	128.022		-36.8971	-45.0003	-45.0003
140	132.226		-30.9371	-40.0003	-40.0003
145	136.453		-25.1369	-35.0003	-35.0003
150	140.75		-19.5656	-30.0003	-30.0003
155	145.163		-14.2656	-25.0003	-25.0003
160	149.739		-9.26995	-20.0003	-20.0003
165	154.52		-4.58274	-15.0003	-15.0003
170	159.541		-0.1923	-10.0003	-10.0003
175	164.83		3.52702	-5.0003	-5.0003
			7.01092	-3.01944E-4	-3.01944E-4

FIGURE A-13. Computer Simulation Results



3. M60 tank - With the compass located at the bottom rear center the disturbance consists of all three types: PM, Symmetrical Soft Iron and Assymetrical Soft Iron. The first two types of disturbance may be compensated for by using the PM, and N/S to E/W ratio correction. With these corrections applied heading errors of up to 15° still remain, due to the uncompensated assymetrical soft iron. A method for correction of assymetrical soft iron errors has been devised. During calibration the vehicle is driven in a circle and the output of the magnetic compass is compared with a gyro compass and the differences stored in a memory for use during operation. The gyro compass is used only during calibration and can be an inexpensive, short term type. The gyro-compass is used only to compensate for assymetrical soft iron. PM correction may still be performed automatically in the field. Since ammo and equipment loaded onto the vehicle cause changes in the PM portion of the vehicle disturbance it is expected that the vehicle could still be automatically recalibrated for load changes in the field.

In addition to the above magnetic disturbances heading error occurs whenever the turret is rotated. A method of correction of these errors has also been devised. During the last calibration step the vehicle is headed in a fixed direction and the turret rotated through 360° . The position of the turret is monitored and the changes in the heading are stored in a memory. This data is then used to apply a heading correction for different turret positions during vehicle operation.

It is proposed that a two module general purpose vehicle navigator be developed. The first module would contain the calibration circuitry for PM and symmetrical soft iron. With the addition of a flux gate compass the first module would form a navigation system for jeeps and APC's. With the addition of the second module, containing the assymetrical soft iron and turret compensation circuitry, a system for use on tanks would



be obtained. Even with the added complexity required for operation on a tank it is believed that a sizeable improvement in reliability and a sizeable decrease in system cost can be achieved over directional gyro systems presently in use.

DISTRIBUTION LIST

	<u>Copies</u>
Commander US Army Materiel Command ATTN: AMCDL 5001 Eisenhower Avenue Alexandria, VA 22333	1
Commander US Army Materiel Command ATTN: AMCRD 5001 Eisenhower Avenue Alexandria, VA 22333	3
Commander US Army Materiel Command ATTN: AMCRD-P 5001 Eisenhower Avenue Alexandria, VA 22333	1
Director of Defense, Research & Engineering Department of Defense WASH DC 20301	1
Director Defense Advanced Research Projects Agency WASH DC 20301	3
HQDA (DARD-DDC) WASH DC 20310	4
HQDA (DARD-ARZ-C) WASH DC 20310	1
HQDA (DAFD-ZB) WASH DC 20310	1
HQDA (DAMO-PLW) WASH DC 20310	1
Commander US Army Training & Doctrine Command ATTN: ATCD Fort Monroe, VA 23651	1

Commander US Army Combined Arms Combat Developments Activity (PROV) Fort Leavenworth, KS 66027	1
Commander US Army Logistics Center Fort Lee, VA 23801	1
Commander US Army CDC Intelligence & Control Systems Group Fort Belvoir, VA 22060	1
TRADOC Liaison Office HQS USATECOM Aberdeen Proving Ground, MD 21005	1
Commander US Army Test and Evaluation Command Aberdeen Proving Ground, MD 21005	1
Commander US Army John F. Kennedy Center for Military Assistance Fort Bragg, NC 28307	1
Commander-In-Chief US Army Pacific ATTN: GPOP-FD APO San Francisco 96558	1
Commander Eighth US Army ATTN: EAGO-P APO San Francisco 96301	1
Commander Eighth US Army ATTN: EAGO-FD APO San Francisco 96301	1
Commander-In-Chief US Army Europe ATTN: AEAGC-ND APO New York 09403	4
Commander US Army Alaska ATTN: ARACD APO Seattle 98749	1

Commander MASSTER ATTN: Combat Service Support & Special Programs Directorate Fort Hood, TX 76544	1
Commander US MAC-T & JUSMAG-T ATTN: MACTRD APO San Francisco 96346	2
Senior Standardization Representative US Army Standardization Group, Australia c/o American Embassy APO San Francisco 96404	1
Senior Standardization Representative US Army Standardization Group, UK Box 65 FPO New York 09510	1
Senior Standardization Representative US Army Standardization Group, Canada Canadian Forces Headquarters Ottawa, Canada K1A0K2	1
Director Air University Library ATTN: AUL3T-64-572 Maxwell Air Force Base, AL 36112	1
Battelle Memorial Institute Tactical Technical Center Columbus Laboratories 505 King Avenue Columbus, OH 43201	1
Defense Documentation Center (ASTIA) Cameron Station Alexandria, VA 22314	12
Commander Aberdeen Proving Ground ATTN: STEAP-TL Aberdeen Proving Ground, MD 21005	2
Commander US Army Edgewood Arsenal ATTN: SIUEA-TS-L Aberdeen Proving Ground, MD 21010	1

US Marine Corps Liaison Officer
Aberdeen Proving Ground, MD 21005

1

Director
Night Vision Laboratory
US Army Electronics Command
ATTN: AMSEL-IV-D (Mr. Goldberg)
Fort Belvoir, VA 22060

1

Commander
US Air Force Special Communications Center (USAFSS)
ATTN: SUR
San Antonio, TX 78243

1

Commander
US Army Armament Command
ATTN: AMSAR-ASF
Rock Island, IL 61201

1