

AD-781 593

INDUCTIVE FATIGUE DETECTOR: FIELD
SYSTEM DEVELOPMENT

Leo Hoogenboom, et al

Mechanical Technology, Incorporated

Prepared for:

Army Air Mobility Research and Development
Laboratory

April 1974

DISTRIBUTED BY:

NTIS

National Technical Information Service
U. S. DEPARTMENT OF COMMERCE
5285 Port Royal Road, Springfield Va. 22151

<input checked="" type="checkbox"/> Write Section <input type="checkbox"/> Buff Section	DISTRIBUTION/AVAILABILITY CODE A.A.L. 000/00
UNCLASSIFIED	A

Eustis Directorate Position Statement

The nondestructive inspection (NDI) system uses the rotating inductive probe concept first advanced and investigated under an earlier Eustis Directorate contract. Its design was optimized for aluminum since it was upon aluminum fatigue samples that the rotating configurations studied in the earlier work showed the highest sensitivity to incipient fatigue damage.

The device was initially evaluated at the U.S. Army Aeronautical Depot Maintenance Center in Corpus Christi, Texas, where it proved to be highly effective in detecting discontinuities and flaws in geometrically simple surface configurations. For complexly shaped surfaces, however, the system's capabilities are quite limited in that the regions of prime NDI importance in such structures are often creviced in areas inaccessible to the comparatively large, blunt-tipped probes.

The conclusions and recommendations contained herein are concurred in by this Directorate.

The technical monitor for this contract was CPT Paul J. Luczka, Military Operations Technology Division.

DISCLAIMERS

The findings in this report are not to be construed as an official Department of the Army position unless so designated by other authorized documents.

When Government drawings, specifications, or other data are used for any purpose other than in connection with a definitely related Government procurement operation, the United States Government thereby incurs no responsibility nor any obligation whatsoever; and the fact that the Government may have formulated, furnished, or in any way supplied the said drawings, specifications, or other data is not to be regarded by implication or otherwise as in any manner licensing the holder or any other person or corporation, or conveying any rights or permission, to manufacture, use, or sell any patented invention that may in any way be related thereto.

Trade names cited in this report do not constitute an official endorsement or approval of the use of such commercial hardware or software.

DISPOSITION INSTRUCTIONS

Destroy this report when no longer needed. Do not return it to the originator.

Unclassified

AD-781593

SECURITY CLASSIFICATION OF THIS PAGE (When Data Entered)

REPORT DOCUMENTATION PAGE		READ INSTRUCTIONS BEFORE COMPLETING FORM
1. REPORT NUMBER USAAMRDL-TR-73-67	2. GOVT ACCESSION NO.	3. RECIPIENT'S CATALOG NUMBER
4. TITLE (and Subtitle) Inductive Fatigue Detector - Field System Development	5. TYPE OF REPORT & PERIOD COVERED Final	
	6. PERFORMING ORG. REPORT NUMBER MTI-73TR35	
7. AUTHOR(s) Leo Hoogenboom Richard Dorman George Moross	8. CONTRACT OR GRANT NUMBER(s) DAAJ02-72-C-0034	
	10. PROGRAM ELEMENT, PROJECT, TASK AREA & WORK UNIT NUMBERS Task 1F162203A43405	
5. PERFORMING ORGANIZATION NAME AND ADDRESS Mechanical Technology Incorporated 968 Albany-Shaker Road Latham, New York 12110	12. REPORT DATE April 1974	
	13. NUMBER OF PAGES 29	
11. CONTROLLING OFFICE NAME AND ADDRESS Eustis Directorate, U.S. Army Air Mobility Research and Development Laboratory Fort Eustis, Virginia	15. SECURITY CLASS. (of this report) Unclassified	
	15a. DECLASSIFICATION/DOWNGRADING SCHEDULE	
14. MONITORING AGENCY NAME & ADDRESS (if different from Controlling Office)		
16. DISTRIBUTION STATEMENT (of this Report) Approved for public release; distribution unlimited.		
17. DISTRIBUTION STATEMENT (of the abstract entered in Block 20, if different from Report)		
18. SUPPLEMENTARY NOTES		
19. KEY WORDS (Continue on reverse side if necessary and identify by block number) Detection system Detection Cracks Fatigue (mechanics)		
20. ABSTRACT (Continue on reverse side if necessary and identify by block number) This report describes the hardware development of a rotating inductive flaw detector, based on an experimental unit built under a previous phase of the program. A complete self-contained transducer and readout unit for field use on aluminum is described and documented. Included are results of design experiments, manufacturing drawings, and tests of standard fatigue specimens. Reproduced by NATIONAL TECHNICAL INFORMATION SERVICE U.S. Department of Commerce Springfield, VA 22151		

DDC
RECEIVED
JUL 11 1974
REGISTRY

TABLE OF CONTENTS

	<u>Page</u>
LIST OF ILLUSTRATIONS	v
INTRODUCTION	1
THEORY OF OPERATION	3
SYSTEM DESIGN CRITERIA	5
RESULTS OF DESIGN EXPERIMENTS	6
DISCUSSION	8
FATIGUE TEST DATA	9
ELECTRONIC SYSTEM DESCRIPTION	16
Motor Voltage Regulator	16
Electronics System Voltage Regulator	16
50 kHz Oscillator	22
Bridge and Probe Amplifier	22
Carrier-Demodulator	22
Inputs and Outputs of Board No. 2	23
Crack Alarm Circuit	24
Crack Direction Detector	24
Battery and Battery Charger Circuit	25
CONCLUSIONS AND RECOMMENDATIONS	27

LIST OF ILLUSTRATIONS

<u>Figure</u>		<u>Page</u>
1	Inductive Rotating Crack Detecting Probe and Laboratory Electronics	2
2	Inductive Crack Detector With Rotating Sensor Packaged for Use in the Field	4
3	Inductive Crack Detector Shown Being Applied	4
4	Sheet Fatigue Specimen	10
5	Inductive Fatigue Detector Normalized Output Versus Percent of Life Expended for Aluminum Fatigue Specimen (Tests No. 1-4)	11
6	Inductive Fatigue Detector Normalized Output Versus Percent of Life Expended for Aluminum Fatigue Specimen (Tests No. 5-8)	12
7	Inductive Fatigue Detector Normalized Output Versus Percent of Life Expended for Aluminum Fatigue Specimen (Tests No. 9-12)	13
8	Inductive Fatigue Detector Normalized Output Versus Percent of Life Expended for Aluminum Fatigue Specimen (Tests No. 13-16)	14
9	Inductive Fatigue Detector Normalized Output Versus Percent of Life Expended for Aluminum Fatigue Specimen (Tests No. 17-20)	15
10	Block Diagram of Inductive Fatigue Detector	17
	Inductive Fatigue Detector-Board #1, Dwg. 10E000032	18
	Inductive Fatigue Detector-Board #2, Dwg. 10D000132	19
	Inductive Fatigue Detector-Schematic, Dwg. 10D000133	20
	Inductive Assembly	21

INTRODUCTION

The objective of this program was to design, construct, and test a field model prototype of the inductive fatigue detection system, which has been reported upon earlier.^{1,2} The field model incorporates recently developed concepts, design improvements, higher sensitivity, and greater flexibility in a battery-operated, hand-carried system.

The present configuration, which was aimed at field and shop use, has had all adjustments removed from the front panel and has been optimized for use on aluminum. During the performance of previous work,¹ three materials were selected for vibratory beam fatigue testing and periodic scanning: 6061-T6 aluminum, 9310 steel, and Inconel X. The detection system generally showed an equal ability to detect incipient fatigue damage (microcracking) at an early point in the life of the specimen among the three materials selected. Aluminum showed the earliest signals, and was later chosen as the material for which the system was to be optimized.

The sections of the report which follow discuss the development and test, and present test results and manufacturing drawings.

¹Moross, George C., INVESTIGATION TO DETERMINE THE FEASIBILITY OF DETECTING IMPENDING METAL FATIGUE FAILURE THROUGH USE OF AN INDUCTIVE SENSING DEVICE, Mechanical Technology Inc., USAAVLABS Technical Report 69-97, U.S. Army Aviation Materiel Laboratories, Fort Eustis, Virginia, February, 1970, AD 871155.

²Moross, George C., INDUCTIVE SENSING TECHNIQUE ADVANCEMENT, Mechanical Technology Inc., USAAMRDL Technical Report 71-51, U.S. Army Air Mobility Research and Development Laboratory, Fort Eustis, Virginia, September, 1971, AD 734342.

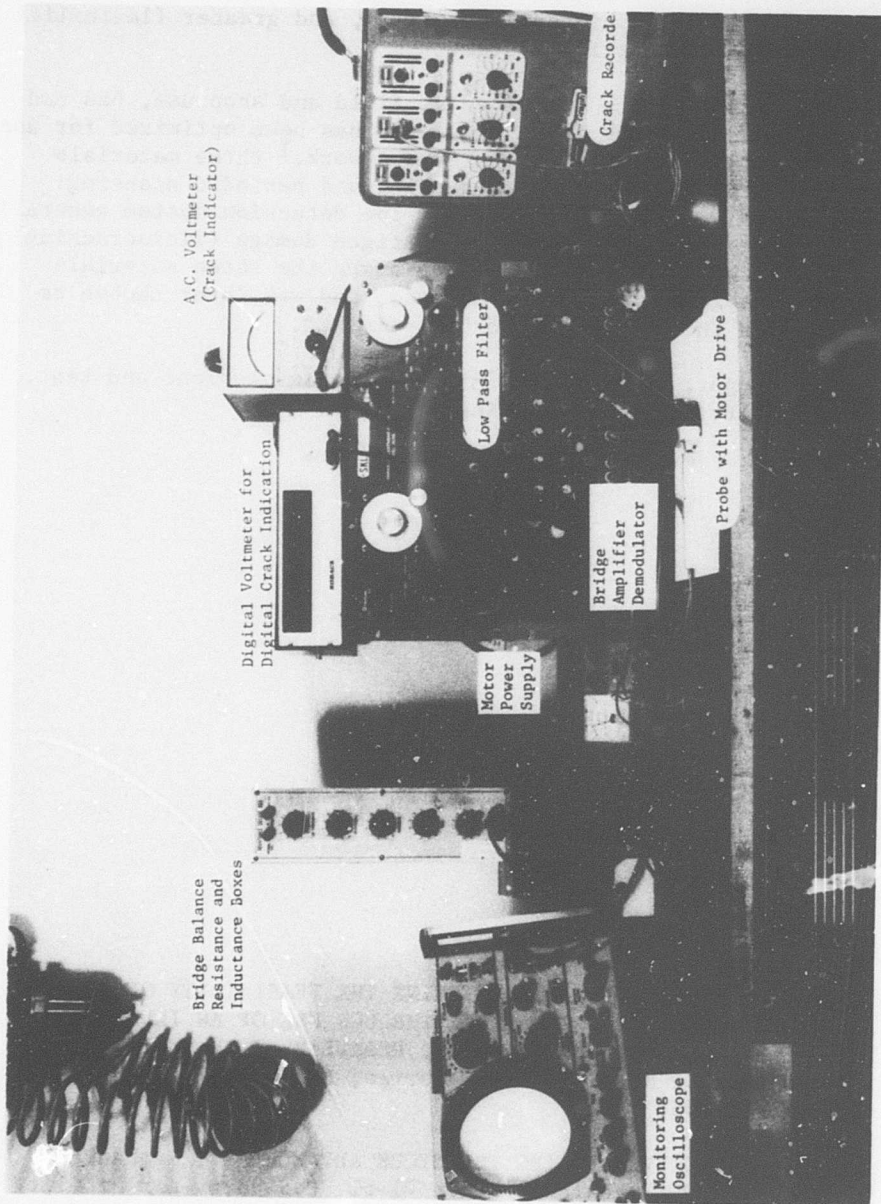

Figure 1. Inductive Rotating Crack Detecting Probe and Laboratory Electronics,

THEORY OF OPERATION

The inductive sensing system delivered under this contract consists of four probes and a case containing the batteries and electronics system. A detailed circuit description is given on pages 17 through 23. Photographs of the field unit are shown in Figures 2 and 3.

The basic probe design consists of a "U"-shaped core with a winding of copper wire at the center of the "U". This coil-core combination is placed in one leg of an AC bridge circuit which is powered by an oscillator. The signal output of the bridge is detected, filtered and presented as an output which is a function of crack size. The probe is positioned so that the sample forms the flux path between the legs of the "U" and the flux passes through the sample material. When the bridge is initially balanced with the probe over good material and then the probe moved to cracked or otherwise flawed material, the bridge will indicate an unbalance due to the change in material properties, as seen both by changes in the reluctance of the path and in the eddy currents in the material. If the elementary single coil-core probe, as described above, is physically scanned over a cracked sample, it will be seen that the signal output (or detectability in terms of bridge unbalance) is a function of the angular relationship between the flux and the crack. If it is assumed that a crack is linear at least over the width of the probe, the probe may be rotated over the crack with the bridge output showing two signals maxima and two signals minima per 360° probe rotation. If the probe is now rotated at a uniform speed, the twice-per-revolution maxima becomes an AC crack signal with a frequency equal to two times running speed (RPS). This AC signal may then be easily amplified, narrow-bandpass filtered, and rectified to provide the crack signal output. Since the effects of proximity change affect the DC level of the signal, and since other artifacts are either random or once-per-revolution, the signal may be expeditiously filtered to remove nearly all "noise," thus presenting an unambiguous indication of a crack.

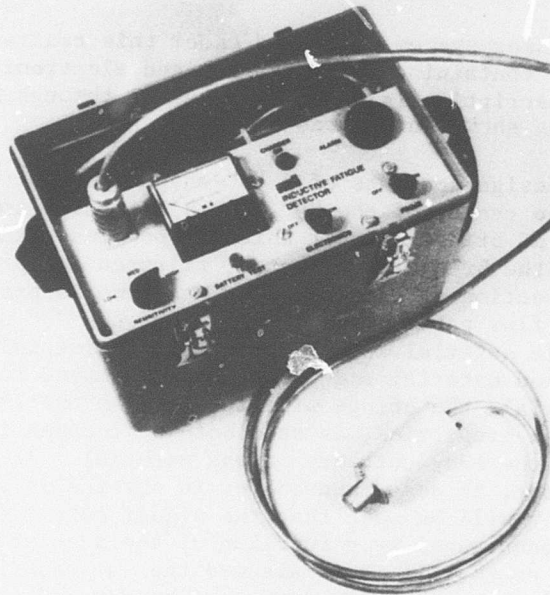

Figure 2. Inductive Crack Detector
Rotating Sensor Packaged
for Use in the Field.

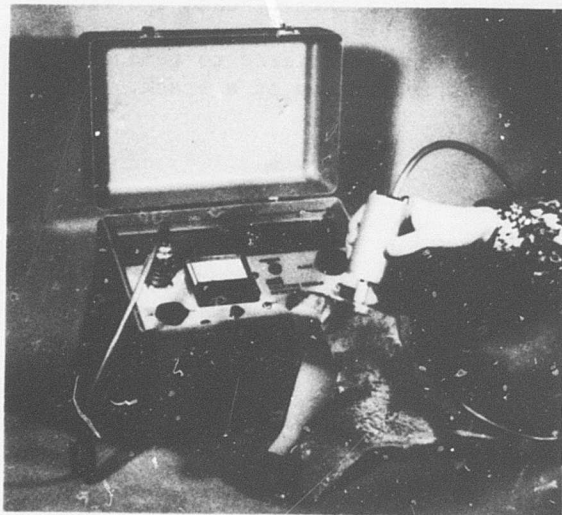

Figure 3. Inductive Crack Detector
Shown Being Applied.

SYSTEM DESIGN CRITERIA

The design of the system was the initial task, and included both probe and electronics.

The requirements for the probe(s) consisted of the following:

- a. Four probes were to be supplied, varying in size and hence application.
- b. The probes were to be interchangeable.
- c. A minimum of readjustment (none preferably) was to be required upon change of probe.
- d. A crack direction indicator was to be incorporated on one or more probes to determine its usefulness.
- e. The probes were to be rugged, in keeping with the intended field and shop use.

The requirements for the case and electronics were as follows:

- a. The inductive fatigue detector (I.F.D.) was to be a self-contained, hand- or shoulder-carried package capable of operation under field conditions.
- b. The power supply was to include rechargeable batteries to allow field operation for up to 8 hours prior to recharging.
- c. The I.F.D. was to be fully operable during the recharging cycle.
- d. Two readouts were to be available--visible and audible.
- e. The system was to have a sensitivity as measured by "percentage of life at time of signal," at least as high as previously reported.

RESULTS OF DESIGN EXPERIMENTS

One of the important and early trade-offs in the probe design was the solution of the problem of getting the probe signal from the rotating probe to the nonrotating case. Two approaches were available: a high-quality slip-ring assembly as tried previously, and a rotating transformer. The slip rings used before perform satisfactorily; however, maintenance is occasionally required in the form of careful cleaning and perhaps brush tension adjustments. Additionally, since signals being carried by the slip rings are at the microvolt level, noise generated in the moving contact may become significant. Hence, a rotating coupling transformer was investigated.

The rotating transformer as a means of coupling the probe to the carrier was investigated. A number of transformer concepts were constructed and evaluated. The purpose of the transformer was to attempt to eliminate physical contact between the rotating member (probe) and the stationary member (carrier). Thus, the problem was to couple the probe coil to the electronics at a point just behind the probe tip without introducing undue attenuation or noise. Initially, rotatable coupling transformers were designed and constructed providing both 1:1 turns ratio and 10:1 turns ratio. Evaluation of these indicated that the 10:1 ratio provided no electronic advantage and was more difficult to fabricate in a small size. Three transformers were constructed having 1:1 turns ratios and 100, 33, and 125 turns, respectively. The reduction in signal strength using these transformers was a factor of 3-10 compared to signals obtained by coupling directly through slip rings. When these transformers were rotated, a significant amount of synchronous noise was generated due mainly to mechanical characteristics such as end play in the motor bearings and radial play in the transformer alignment. When these effects were minimized by more careful alignment, the total degradation in signal-to-noise ratio was measured at a factor of 10, as compared to performance of a probe coupled through slip rings. Due to the above results, the slip-ring approach seemed advisable.

The slip-ring assembly (identical to the one used on Contract DAAJ02-70-C-0028) was evaluated for potential use in this program. After a period of running at a speed well below the upper limit quoted in the specifications, the noise generated became objectionable. The manufacturer was contacted and a different ring material was recommended. A silver versus silver-graphite slip-ring brush assembly was evaluated. The rings, however, were .812 inch O.D., considerably larger than desired. Signal-to-noise ratio was of the order of 40:1, which was comparable to the best previous experience and was deemed acceptable. A test on these rings of 80 hours continuous running was performed with very slight wear and a negligible increase in noise. The noise was also "white" in nature and did not show the disturbing 2X rotational frequency as shown by the preceding rings. This 2X rotation noise was considered to be quite serious in that a bandpass filter would not be able to remove it, while looking for a 2X rotation crack signal, and the noise being rectified would be indistinguishable from the signal. The manufacturer was contacted subsequent to these tests,

and he supplied special silver/silver-graphite rings in a .260-inch diameter for this program. Since the material combination was rated for 5000 SFM (surface feet per minute), the 4500 rpm final rotational speed of the slip rings was quite conservative.

The remaining trade-off was of lesser magnitude but the subject of serious consideration. After a study of the intended use of the instrument, it was deemed advisable to allow operation from batteries. Since the unit would likely be stored between use in an area containing 115 VAC power, the nickel-cadmium battery with 115 VAC charger was an obvious choice. The provision of recharging from 28 VDC aircraft power was considered, but it was deemed not necessary and hence was not included.

DISCUSSION

GENERAL DESCRIPTION

The present effort has concentrated upon development of a field-portable version of the inductive fatigue detection system. The major functional characteristics of the inductive system are:

1. Cracks are detected at the microcrack size level, as small as 10^{-5} inches in width.
2. The system could be optimized to perform well with both ferrous and nonferrous metals.
3. The system employs a rotating probe and hence is relatively insensitive to standoff, tilt and surface condition.

Surface conditions such as paint, anodizing, grease, oil, and rough machine finish have been investigated and have been seen to have little or no effect on the system's ability to detect microcracks; in fact, anodizing, since it is a brittle coating well bonded to the aluminum, allowed even earlier detection of fatigue damage. Briefly, the operation of the system is not affected deleteriously by surface condition as long as the probe can be placed in reasonable proximity to the material to be examined, and the intervening material is nonferromagnetic. In the case of ferromagnetic material between the probe and specimen, the flux field is effectively "shorted out" by the intervening layer and does not penetrate into the material in question. In the case of nonferromagnetic metal such as ordinarily used for plating, the effect is negligible.

FATIGUE TEST DATA

Aluminum bending fatigue test specimens of the type shown in Figure 4 were used to test the probe. The fatigue testing machine used was the Model CSS-40, made by Vishay Research and Education Division. The specimen dimensions are as recommended by the manufacturer of the fatigue tester.

The bending stress was chosen at a level where failure would occur in one-half million to three million stress cycles.

Twenty specimens were tested. The probe used has a 1/4-inch core diameter. Its configuration is shown in Drawing No. 277C13, Group 4.

The results are plotted in Figures 5 through 9, which show the normalized instrument output versus the percentage of specimen life expended.

As can be seen from the data, a reasonably close prediction of cycles to failure can be made for the material and stress level used in the test.

Probe output represents a combination of crack length and depth, both of which can vary strongly individually and in combination for a given fatigue history from specimen to specimen. The spread in the data is caused by a variation in crack growth rate (in depth and length) throughout the life of specimens.

The "Normalized Reading" in Figures 5 through 9 are the actual readings taken, multiplied by the attenuation factor. Thus all instrument data is presented on one continuous scale, even though different attenuator settings were used. The audible alarm threshold can be varied over a wide range. The setting can be changed by removing the electronics from the carrying case and by adjusting a potentiometer. The setting at delivery was 25% of full scale with maximum attenuator setting.

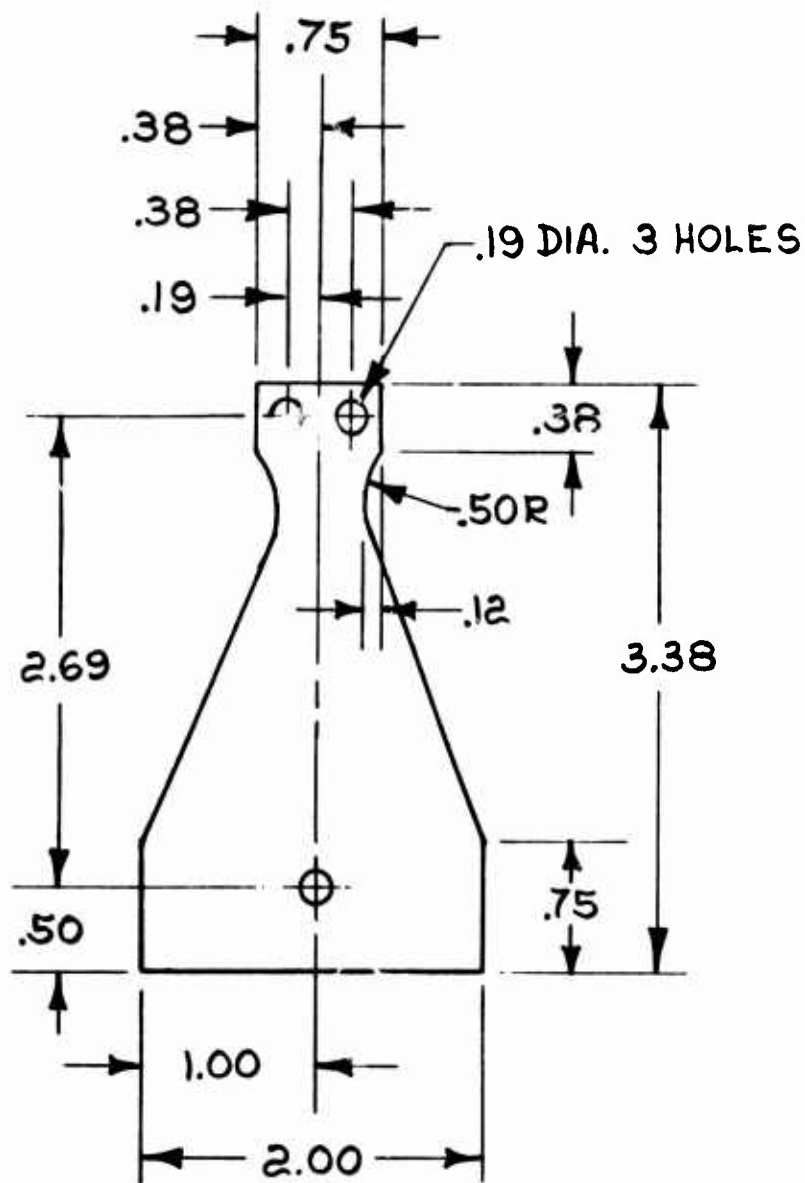

MAT'L. - .125 THK.
6061-T6 ALUM. ALLOY

TOLERANCES ON DECIMALS
.XX ± .02

Figure 4. Sheet Fatigue Specimen.

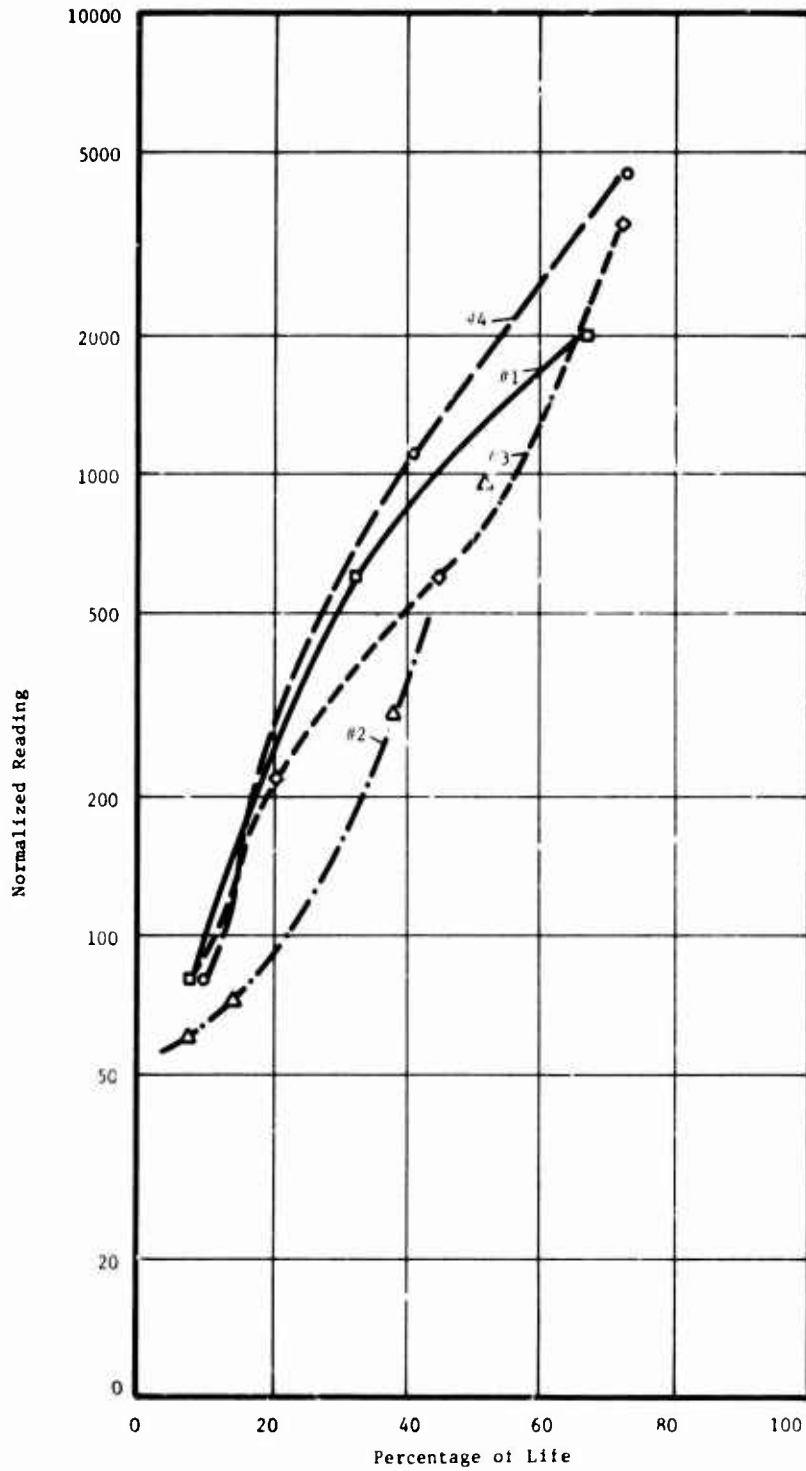

Figure 5. Inductive Fatigue Detector Normalized Output Versus Percent of Life Expended for Aluminum Fatigue Specimen (Tests No. 1-4).

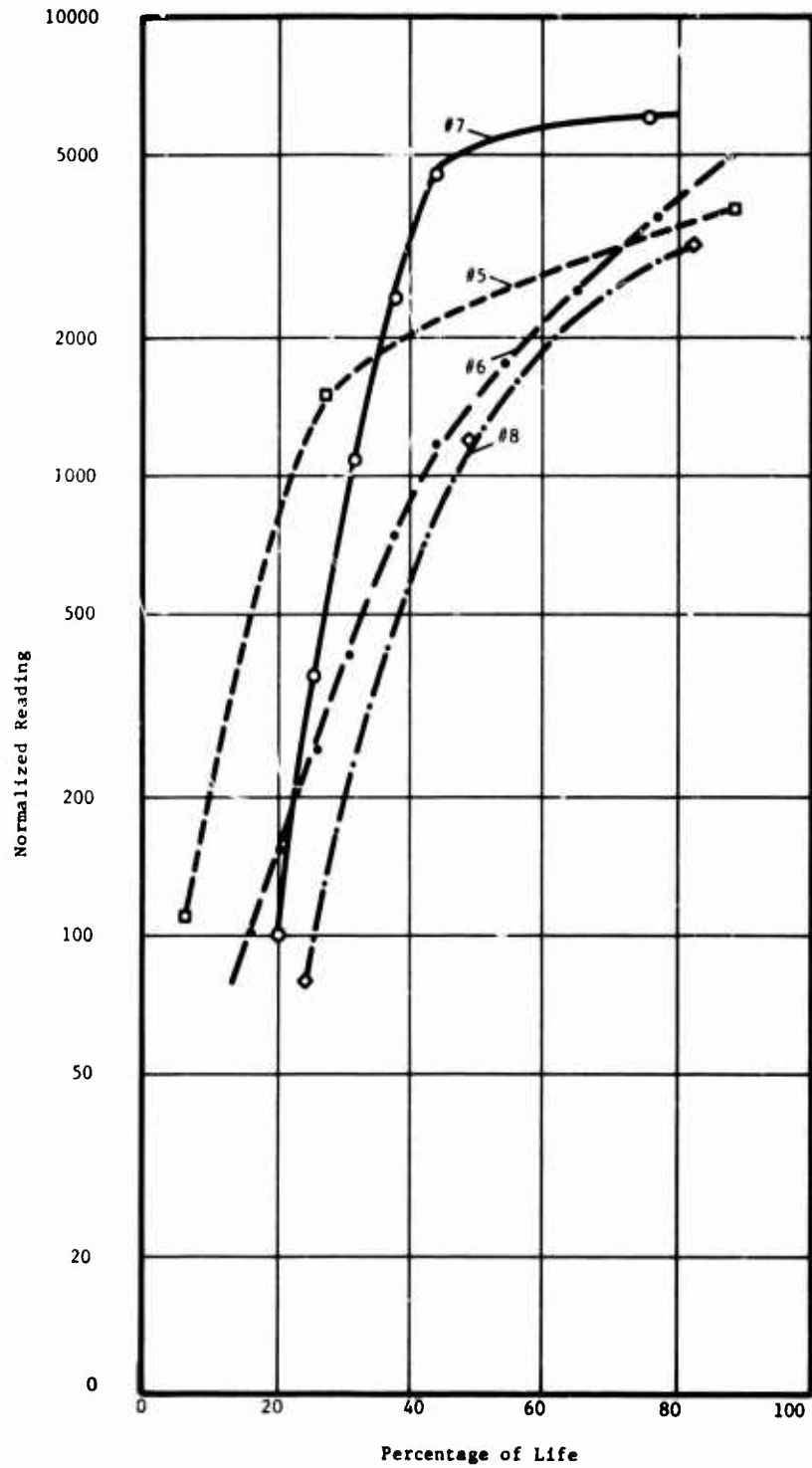

Figure 6. Inductive Fatigue Detector Normalized Output Versus Percent of Life Expended for Aluminum Fatigue Specimen (Tests No. 5-8).

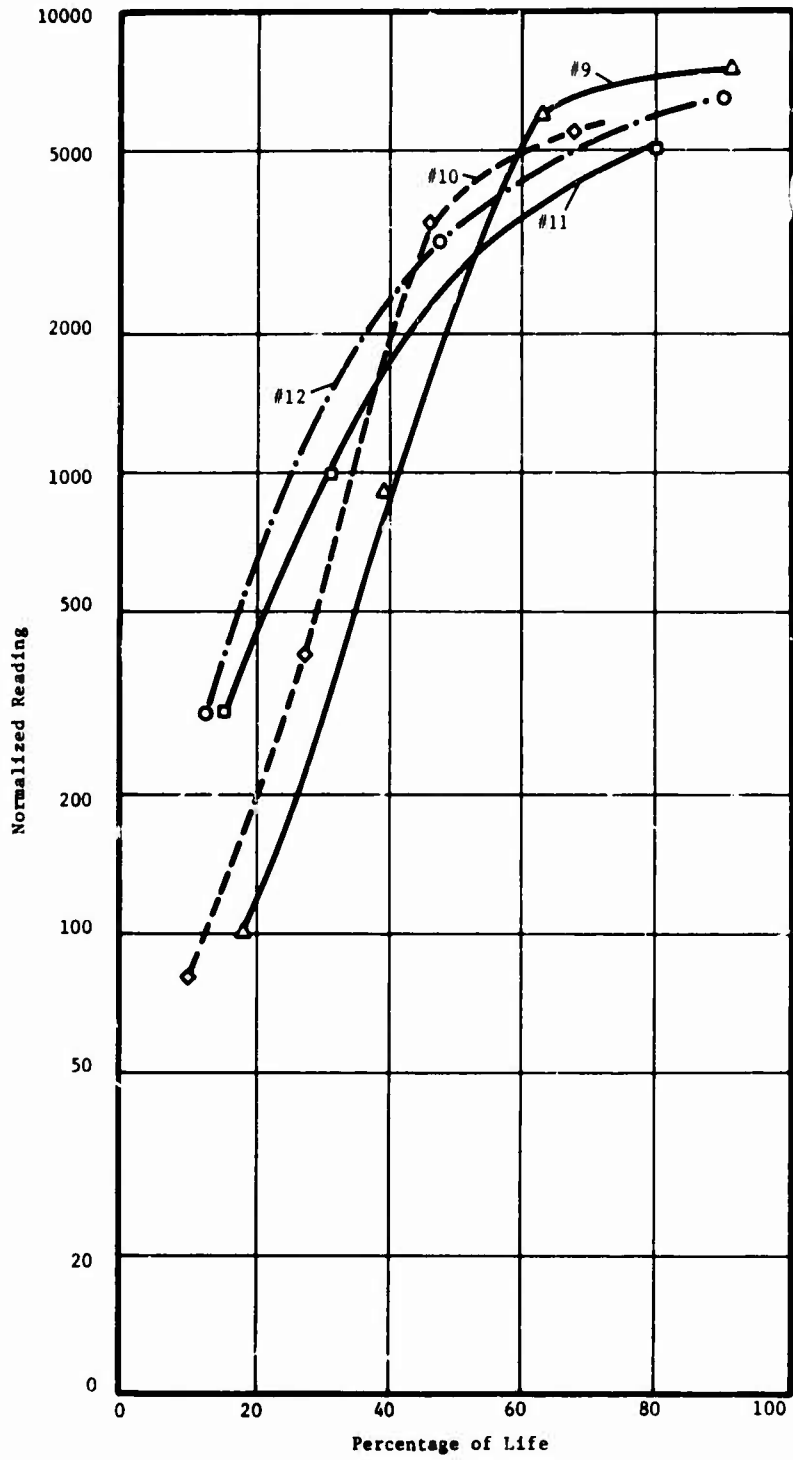

Figure 7. Inductive Fatigue Detector Normalized Output Versus Percent of Life Expended for Aluminum Fatigue Specimen (Tests No. 9-12).

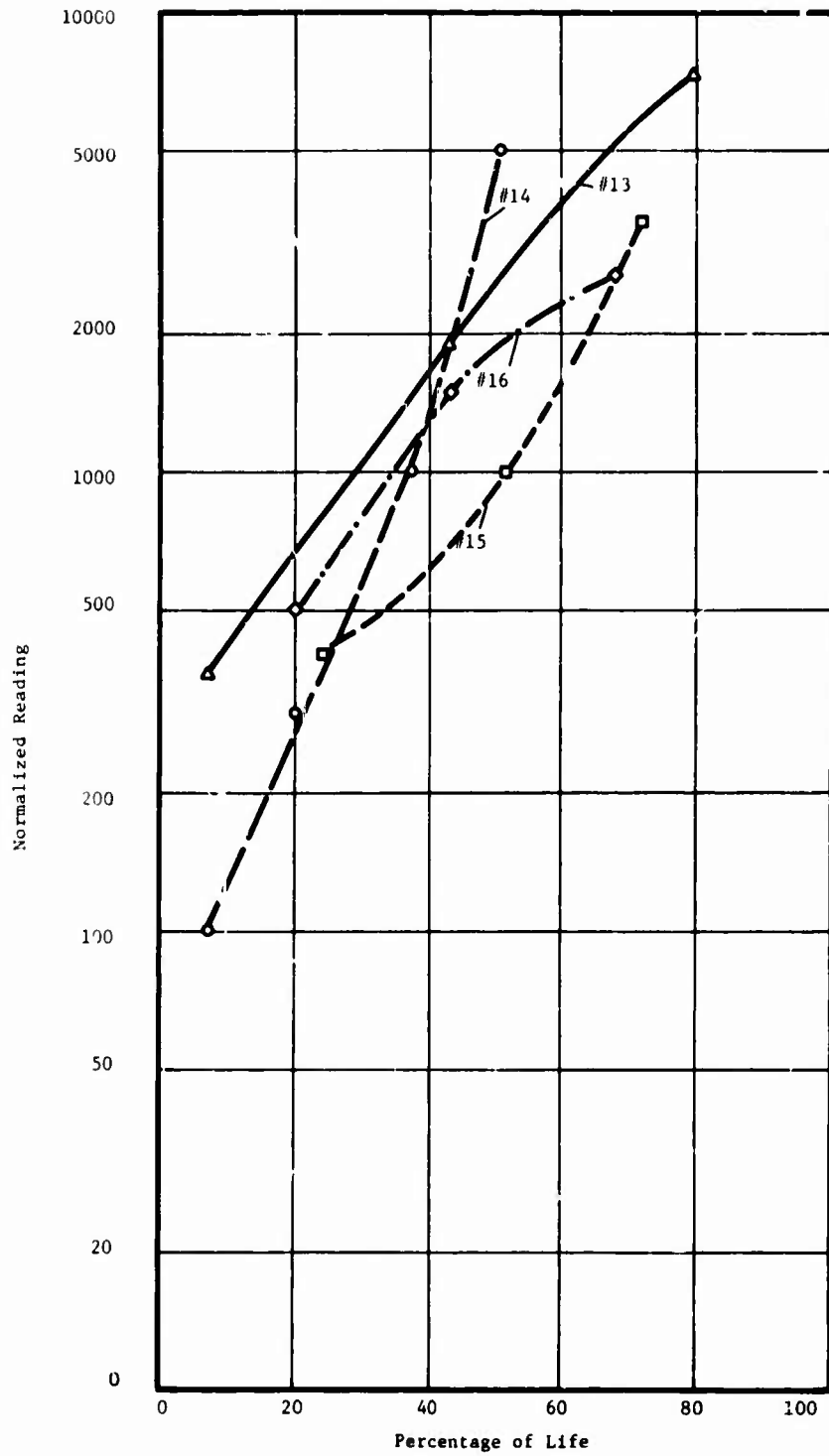

Figure 8. Inductive Fatigue Detector Normalized Output Versus Percent of Life Expended for Aluminum Fatigue Specimen (Tests No. 13-16).

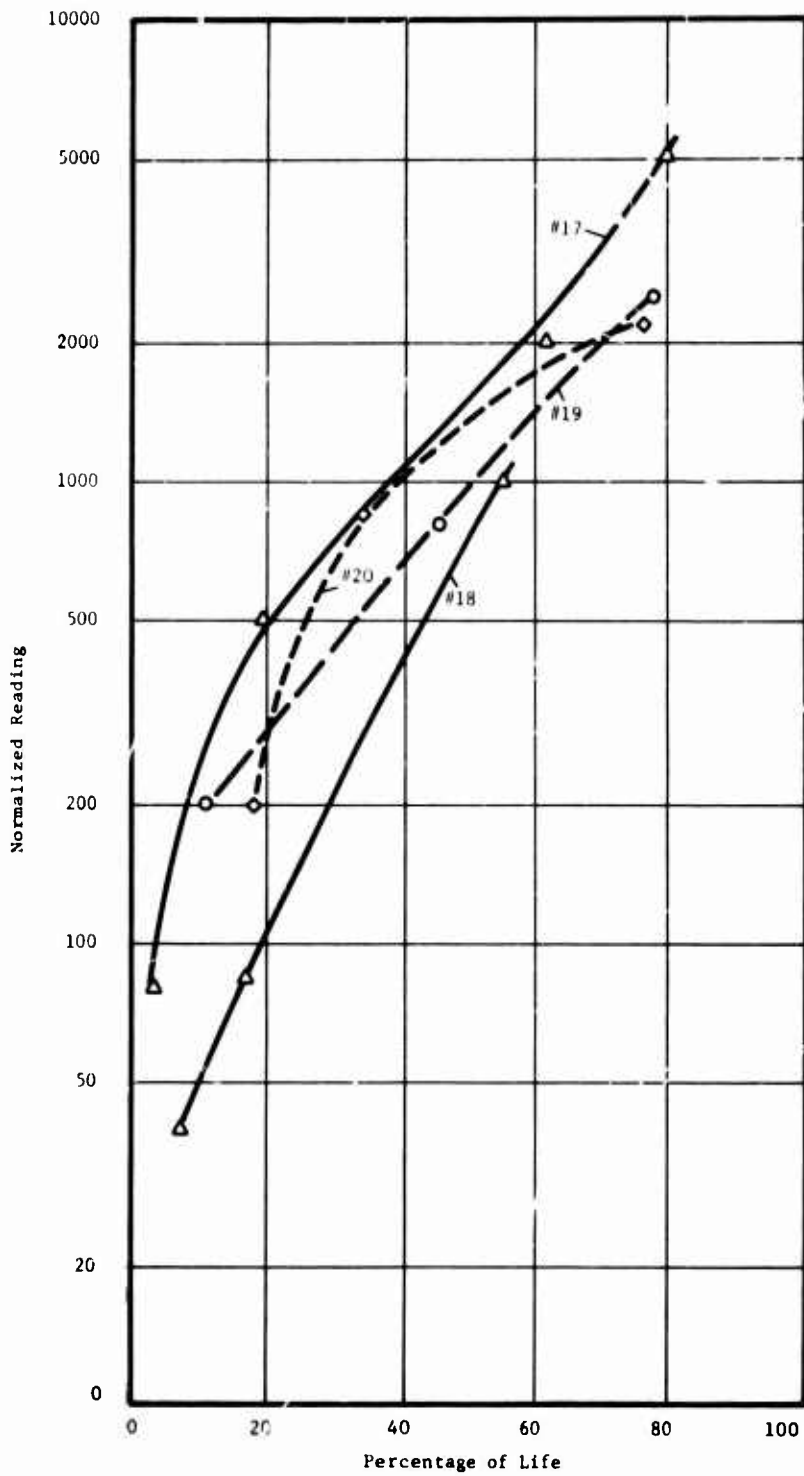

Figure 9. Inductive Fatigue Detector Normalized Output Versus Percent of Life Expended for Aluminum Fatigue Specimen (Tests No. 17-20).

ELECTRONIC SYSTEM DESCRIPTION

The electronics for the rotating crack detection probe are contained on two circuit boards. The schematics for the circuitry on these boards are shown in Drawings 10E000032 and 10D000132. One complete breadboard of this system has been built and tested. The circuit boards shown are held on board guides that are connected to the back of the front panel of the electronics case. A block diagram of the complete system is shown in Figure 10.

Circuit board No. 1 (Dwg. No. 10E000032) contains the following circuitry:

1. The motor voltage regulator (IC1 and IC2)
2. The electronics system voltage regulator (IC3 and IC4)
3. A 50-kHz oscillator (IC5 and IC6)
4. The probe amplifier and bridge reference elements (IC7 and IC8)
5. The carrier demodulator circuit (IC9 and IC10).

Voltage is supplied to the two regulator circuits from the battery, which has an output voltage that varies from 18 volt DC to 21 volt DC, depending on the battery charge state.

MOTOR VOLTAGE REGULATOR

The regulator circuit, which is composed of the integrated circuit regulator IC1 and the amplifier IC2, produces a regulated voltage that causes the probe motor to rotate at a speed of 4500 rpm. This regulator holds the motor voltage within a ± 1 percent tolerance range, thereby maintaining the motor speed constant as the battery voltage varies. Potentiometer R3 provides the means of setting the motor voltage for the proper value of motor speed.

ELECTRONICS SYSTEM VOLTAGE REGULATOR

The second regulator circuit, composed of IC3 and IC4 amplifier circuits, provides a regulated, dual voltage supply for electronics circuitry. The regulator IC3 provides a fixed, regulated voltage of 15 ± 0.5 volts DC from the battery supply. A fixed common voltage for the electronics is established at a potential of +7.5 volts DC above the low side of the battery voltage by the amplifier IC4 circuit. Establishing the electronics common at this potential produces ± 7.5 volts DC supply from the regulated 15 volts DC supply. The total current drawn by both regulators from the battery when the entire circuit is operating is approximately 150 DC milliamps, with the motor drawing 115 DC milliamps, and the electronics drawing the remaining 35 DC milliamps.

The remaining circuitry on board No. 1 performs the functions of providing a carrier signal to the crack detection probe, amplifying the carrier signal that is modulated by the presence of a crack, and detecting the crack signal from the amplified, modulated carrier signal.

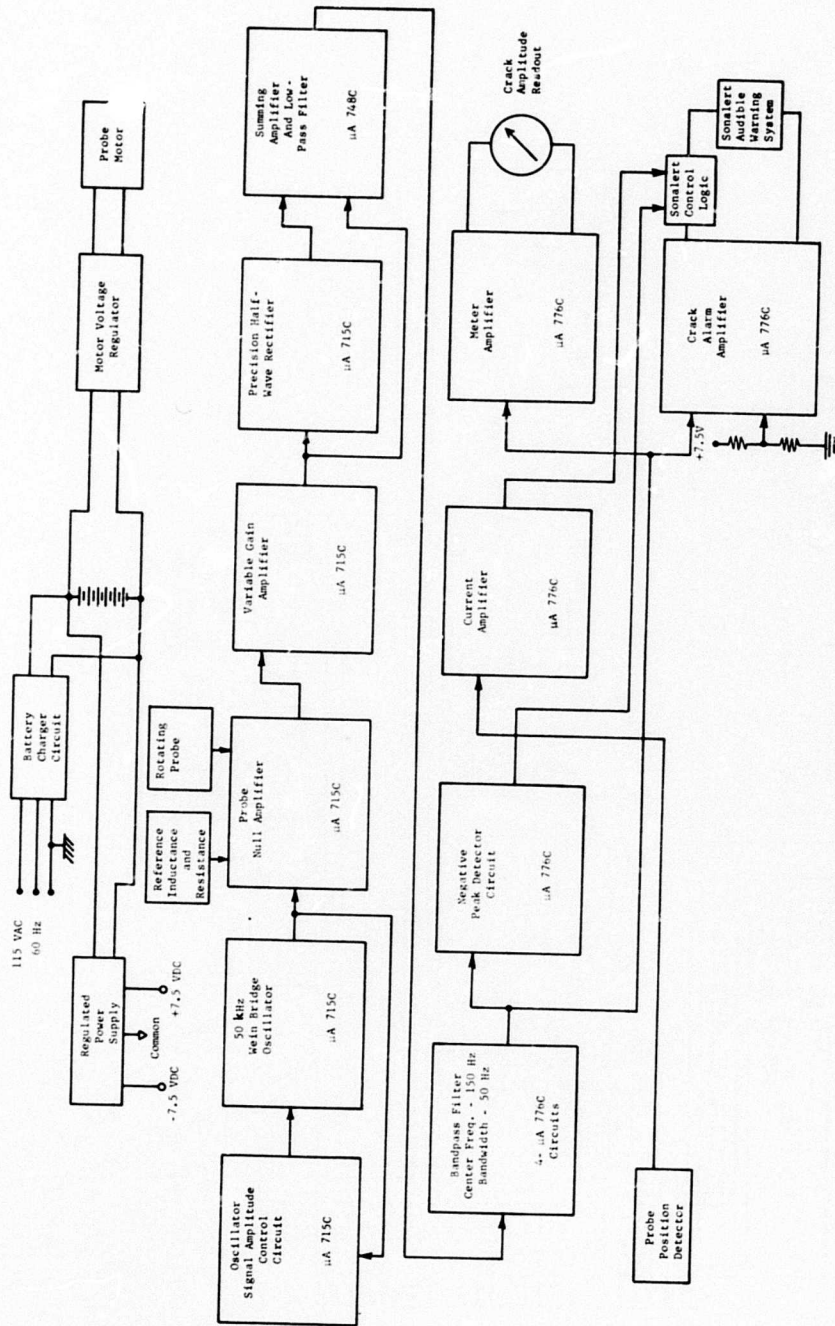
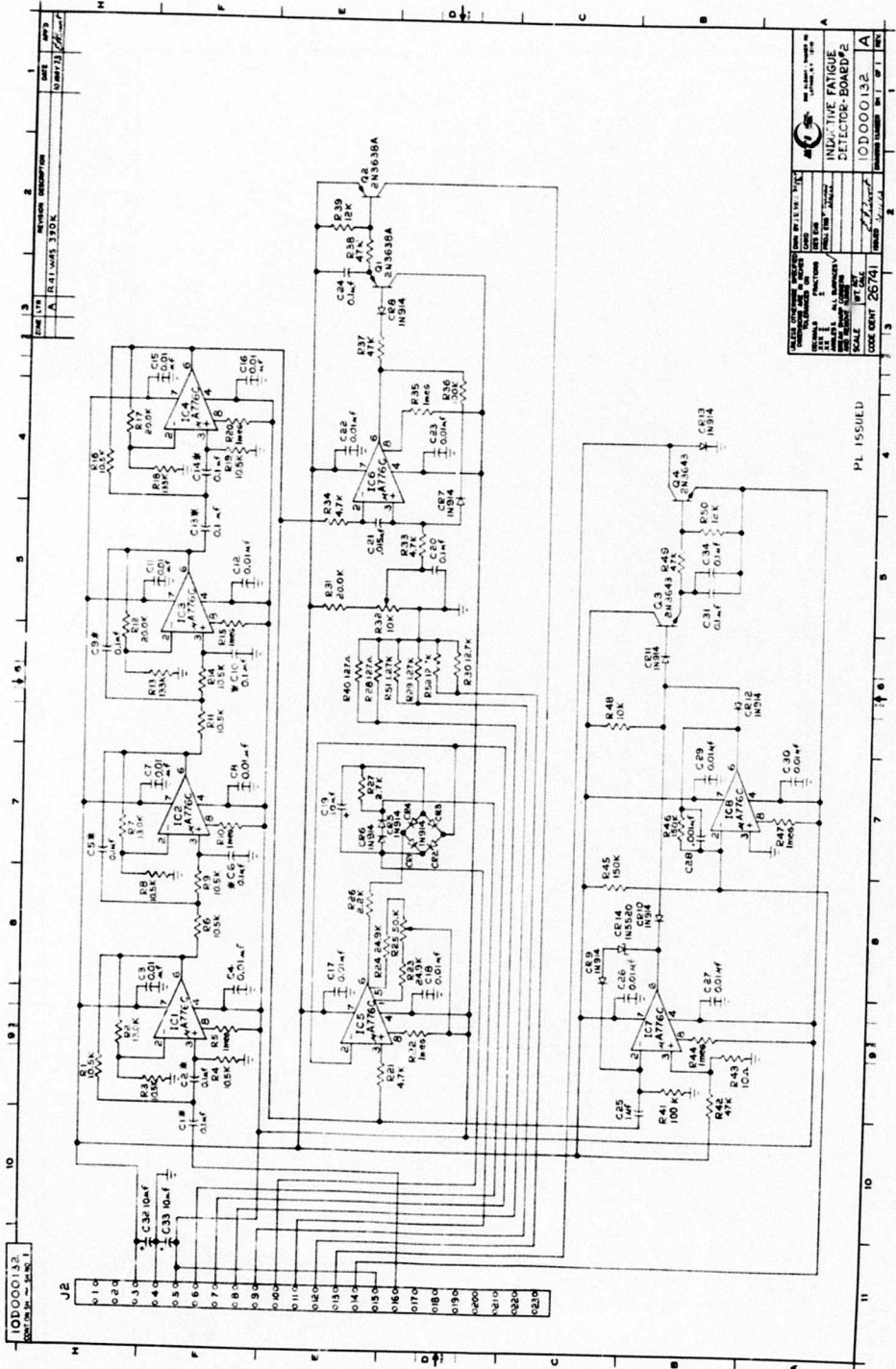

Figure 10. Block Diagram of Inductive Fatigue Detector.



10	010	011	012	013	014	015	016	017	018	019	020	021	022	023
10	010	011	012	013	014	015	016	017	018	019	020	021	022	023

1	2	3	4	5	6	7	8	9	10	11
1	2	3	4	5	6	7	8	9	10	11

PL ISSUED

1	2	3	4	5	6	7	8	9	10	11
1	2	3	4	5	6	7	8	9	10	11

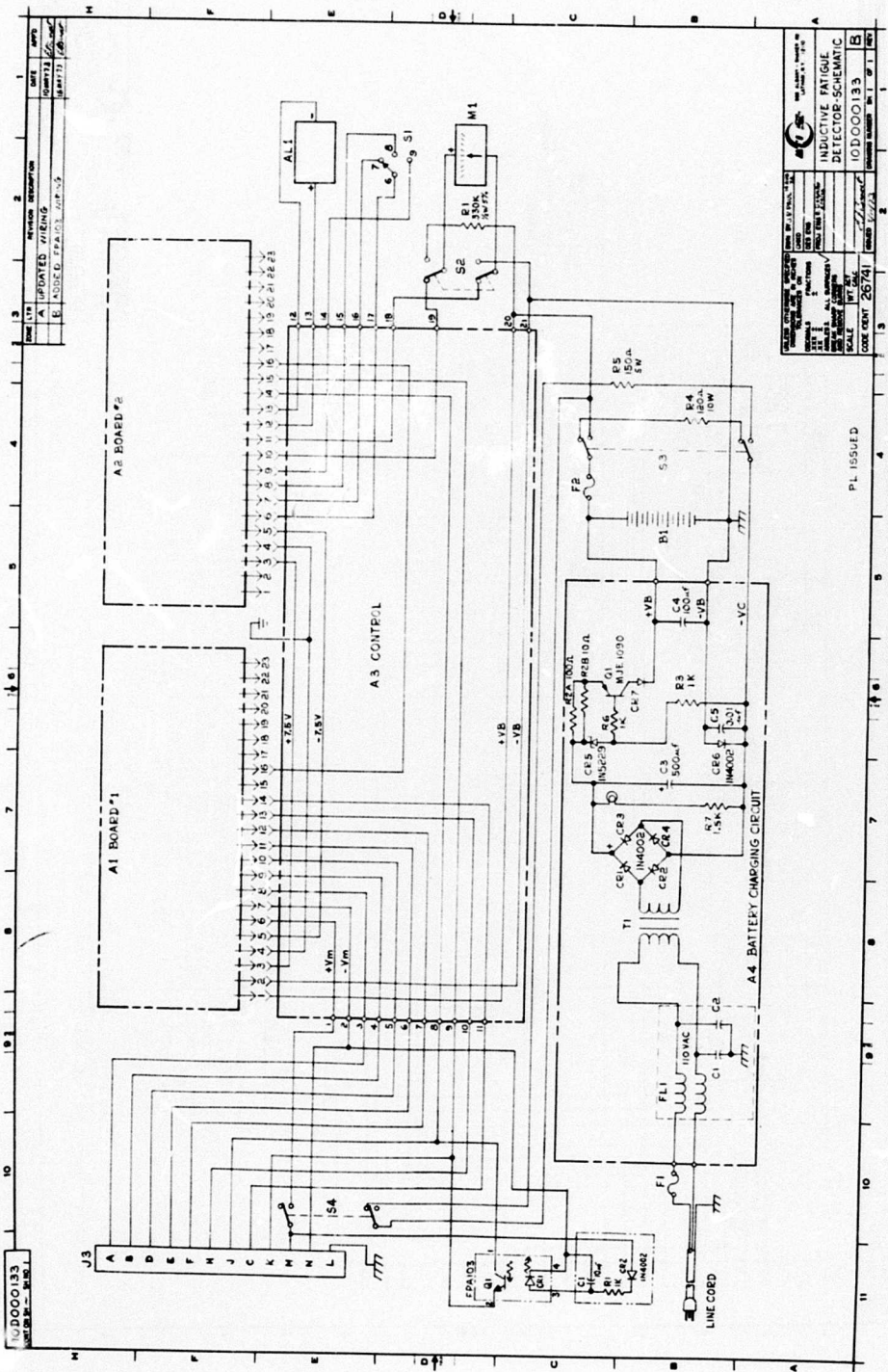

REV	DATE	DESCRIPTION
1	10/12/55	INITIAL
2	11/15/55	REVISED
3	12/15/55	REVISED
4	1/15/56	REVISED
5	2/15/56	REVISED
6	3/15/56	REVISED
7	4/15/56	REVISED
8	5/15/56	REVISED
9	6/15/56	REVISED
10	7/15/56	REVISED
11	8/15/56	REVISED
12	9/15/56	REVISED
13	10/15/56	REVISED
14	11/15/56	REVISED
15	12/15/56	REVISED
16	1/15/57	REVISED
17	2/15/57	REVISED
18	3/15/57	REVISED
19	4/15/57	REVISED
20	5/15/57	REVISED
21	6/15/57	REVISED
22	7/15/57	REVISED
23	8/15/57	REVISED
24	9/15/57	REVISED
25	10/15/57	REVISED
26	11/15/57	REVISED
27	12/15/57	REVISED
28	1/15/58	REVISED
29	2/15/58	REVISED
30	3/15/58	REVISED
31	4/15/58	REVISED
32	5/15/58	REVISED
33	6/15/58	REVISED
34	7/15/58	REVISED
35	8/15/58	REVISED
36	9/15/58	REVISED
37	10/15/58	REVISED
38	11/15/58	REVISED
39	12/15/58	REVISED
40	1/15/59	REVISED
41	2/15/59	REVISED
42	3/15/59	REVISED
43	4/15/59	REVISED
44	5/15/59	REVISED
45	6/15/59	REVISED
46	7/15/59	REVISED
47	8/15/59	REVISED
48	9/15/59	REVISED
49	10/15/59	REVISED
50	11/15/59	REVISED
51	12/15/59	REVISED
52	1/15/60	REVISED
53	2/15/60	REVISED
54	3/15/60	REVISED
55	4/15/60	REVISED
56	5/15/60	REVISED
57	6/15/60	REVISED
58	7/15/60	REVISED
59	8/15/60	REVISED
60	9/15/60	REVISED
61	10/15/60	REVISED
62	11/15/60	REVISED
63	12/15/60	REVISED
64	1/15/61	REVISED
65	2/15/61	REVISED
66	3/15/61	REVISED
67	4/15/61	REVISED
68	5/15/61	REVISED
69	6/15/61	REVISED
70	7/15/61	REVISED
71	8/15/61	REVISED
72	9/15/61	REVISED
73	10/15/61	REVISED
74	11/15/61	REVISED
75	12/15/61	REVISED
76	1/15/62	REVISED
77	2/15/62	REVISED
78	3/15/62	REVISED
79	4/15/62	REVISED
80	5/15/62	REVISED
81	6/15/62	REVISED
82	7/15/62	REVISED
83	8/15/62	REVISED
84	9/15/62	REVISED
85	10/15/62	REVISED
86	11/15/62	REVISED
87	12/15/62	REVISED
88	1/15/63	REVISED
89	2/15/63	REVISED
90	3/15/63	REVISED
91	4/15/63	REVISED
92	5/15/63	REVISED
93	6/15/63	REVISED
94	7/15/63	REVISED
95	8/15/63	REVISED
96	9/15/63	REVISED
97	10/15/63	REVISED
98	11/15/63	REVISED
99	12/15/63	REVISED
100	1/15/64	REVISED

REV	DATE	DESCRIPTION
1	10/12/55	INITIAL
2	11/15/55	REVISED
3	12/15/55	REVISED
4	1/15/56	REVISED
5	2/15/56	REVISED
6	3/15/56	REVISED
7	4/15/56	REVISED
8	5/15/56	REVISED
9	6/15/56	REVISED
10	7/15/56	REVISED
11	8/15/56	REVISED
12	9/15/56	REVISED
13	10/15/56	REVISED
14	11/15/56	REVISED
15	12/15/56	REVISED
16	1/15/57	REVISED
17	2/15/57	REVISED
18	3/15/57	REVISED
19	4/15/57	REVISED
20	5/15/57	REVISED
21	6/15/57	REVISED
22	7/15/57	REVISED
23	8/15/57	REVISED
24	9/15/57	REVISED
25	10/15/57	REVISED
26	11/15/57	REVISED
27	12/15/57	REVISED
28	1/15/58	REVISED
29	2/15/58	REVISED
30	3/15/58	REVISED
31	4/15/58	REVISED
32	5/15/58	REVISED
33	6/15/58	REVISED
34	7/15/58	REVISED
35	8/15/58	REVISED
36	9/15/58	REVISED
37	10/15/58	REVISED
38	11/15/58	REVISED
39	12/15/58	REVISED
40	1/15/59	REVISED
41	2/15/59	REVISED
42	3/15/59	REVISED
43	4/15/59	REVISED
44	5/15/59	REVISED
45	6/15/59	REVISED
46	7/15/59	REVISED
47	8/15/59	REVISED
48	9/15/59	REVISED
49	10/15/59	REVISED
50	11/15/59	REVISED
51	12/15/59	REVISED
52	1/15/60	REVISED
53	2/15/60	REVISED
54	3/15/60	REVISED
55	4/15/60	REVISED
56	5/15/60	REVISED
57	6/15/60	REVISED
58	7/15/60	REVISED
59	8/15/60	REVISED
60	9/15/60	REVISED
61	10/15/60	REVISED
62	11/15/60	REVISED
63	12/15/60	REVISED
64	1/15/61	REVISED
65	2/15/61	REVISED
66	3/15/61	REVISED
67	4/15/61	REVISED
68	5/15/61	REVISED
69	6/15/61	REVISED
70	7/15/61	REVISED
71	8/15/61	REVISED
72	9/15/61	REVISED
73	10/15/61	REVISED
74	11/15/61	REVISED
75	12/15/61	REVISED
76	1/15/62	REVISED
77	2/15/62	REVISED
78	3/15/62	REVISED
79	4/15/62	REVISED
80	5/15/62	REVISED
81	6/15/62	REVISED
82	7/15/62	REVISED
83	8/15/62	REVISED
84	9/15/62	REVISED
85	10/15/62	REVISED
86	11/15/62	REVISED
87	12/15/62	REVISED
88	1/15/63	REVISED
89	2/15/63	REVISED
90	3/15/63	REVISED
91	4/15/63	REVISED
92	5/15/63	REVISED
93	6/15/63	REVISED
94	7/15/63	REVISED
95	8/15/63	REVISED
96	9/15/63	REVISED
97	10/15/63	REVISED
98	11/15/63	REVISED
99	12/15/63	REVISED
100	1/15/64	REVISED

PL ISSUED

COIL FORM - .010 THICK PLASTIC OR CARDBOARD - CUT TO SUIT AT TIME OF ASSY
2 REQ'D

3

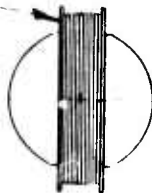

1 COIL CORE - SEE TABLE FOR PT NO

COIL LEADS APPROX 9" LG.

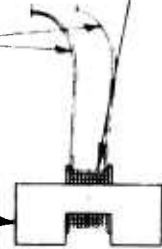

2 COIL - MAGNET WIRE, HEAVY POLY-THERMALEZE (SEE TABLE FOR NO OF TURNS, SIZE & PT NO)
COVER TURNS WITH EPOXY RESIN

GROUP	COIL CORE	WIRE DIAMETER	TURNS	TURNS / LAYER	WIRE PT No	SERIES INDUCTANCE AT 1000 Hz	SERIES RESISTANCE AT 1000 Hz
1	217B11P1	.0063	300	30	BELDEN # 8083		
2	217B11P2	.0063	300	30	BELDEN # 8083		
3	217B11P3	.0063	200	20	BELDEN # 8083		
4	217B11P4	.0063	150	15	BELDEN # 8083		

UNLESS OTHERWISE SPECIFIED DIMENSIONS ARE IN INCHES TOLERANCES ON DECIMALS ± .005 FRACTIONS ± .010 .XXX ± .005 .XX ± .005 ANGLES ± .010 ALL SURFACES BREAK SHARP CORNERS AND REMOVE BURRS		DWN BY <i>[Signature]</i> 5/14/72 CHKD DES. ENG PROJ. ENG	866 ALBANY-SHAKER RD LATHAM, N.Y. 12110
SCALE NONE		INDUCTOR ASSEMBLY	
WT. ACT		277 C13	
CODE IDENT 26741		DRAWING NUMBER SH. 1 OF 1	
ISSUED		REV.	

50 KHZ OSCILLATOR

The carrier signal for the probe is produced by a 50-kHz oscillator composed of amplifier IC6 and its associated components. Capacitors C19 and C24, and resistors R18, R22, and R23 determine the oscillator frequency; and the amplitude control circuit IC5 and its associated components determine the amplitude of the 50-kHz signal presented to the probe amplifier IC7. The IC5 amplifier circuit controls the oscillator signal amplitude by detecting the average amplitude of the oscillator output signal, and using the detected signal voltage to control the gain element of the oscillator. The gain control element for the circuit is transistor Q3, the resistance of which is determined by the amplitude of the detected signal. Adjustment of the amplitude and frequency of the oscillator output signal is provided by potentiometers R15 and R23, respectively. The oscillator signal that is presented to the bridge amplifier circuit has an amplitude of 5.0 ± 0.1 volts peak-to-peak at a frequency of 50.0 ± 2.0 kHz.

BRIDGE AND PROBE AMPLIFIER

The bridge circuit in which the crack signal is developed is composed of amplifier IC7 and its associated circuitry. The bridge is composed of resistors R24 and R27, the inductive and resistive components of the probe, and a reference inductance-resistance pair that is approximately equal in value to the probe impedance. The impedance of the rotating probe is not shown on the schematic of board 1, but will be present in the circuit in parallel with resistor R25. The reference element in the circuit will be one of the inductance-resistance pairs, L1-R37, L2-R38, L3-R39, or L4-R40, and will be in the circuit in parallel with R26. The proper reference element for each size probe is selected by jumper wires in each probe cable connector. In operation, the probe and reference impedances form half the bridge circuit, with resistors R24 and R27 forming the other half of the bridge. The output signal from IC7 is proportional to the impedance difference between the probe and reference elements because resistors R24 and R27 are equal. The bridge is operated slightly off null so that the signal present at the output of IC7 is a 50-kHz carrier signal, the amplitude of which is modulated by the 150-Hz crack signal. This modulated signal is amplified by a factor of 55 by the amplifier circuit IC8 and sent to the input of the demodulator circuit.

CARRIER-DEMODULATOR

The purpose of the demodulator is to detect the amplitude modulation on the amplified 50-kHz carrier signal and to filter out the 50-kHz carrier signal. The amplifiers IC9 and IC10, and their associated circuitry, form a full wave envelope detector-demodulator. Diodes CR7 and CR8 are the switching elements used to perform the signal detection, and capacitor C51 removes the carrier signal from the output of IC10 by filtering out the frequency components above 5 kHz. The output signal from IC10 is primarily a negative voltage level proportional to the magnitude of the 50-kHz carrier signal and the 150-Hz crack signal. Also present at this point is some residual 50-kHz carrier signal and a considerable amount of broadband noise.

These two latter signal components and the negative voltage level will be removed by the next circuit stage, the bandpass filter. This circuit and the remaining system circuitry are on circuit board no. 2.

Circuit board no. 2 contains the following circuitry:

1. the fourth-order bandpass filter (IC1, IC2, IC3, and IC4)
2. the meter amplifier circuit (IC5)
3. the crack alarm circuit
4. the crack direction detector circuit.

INPUTS AND OUTPUTS OF BOARD NO. 2

The power to the circuitry on board no. 2 is provided by the ± 7.5 -volt DC regulator (IC3 and IC4) on board no. 1. The input signals to board no. 2 are the demodulator output signal from IC10 of board no. 1 and the probe direction signal from the rotating probe. The output signals provided by the board no. 2 circuitry are the crack indication meter drive signal and the crack alarm actuation signal.

Bandpass Filter

The first input signal to board no. 2, the demodulator output signal, is fed directly to the input section of a fourth-order bandpass filter. This filter is composed of amplifiers IC1, IC2, IC3, and IC4 and the resistors and capacitors associated with these amplifiers. Amplifiers IC1 and IC4 and their circuitry form a fourth-order Butterworth type high-pass section, and amplifiers IC2 and IC3 and their circuitry form a fourth-order Butterworth type low-pass section. The filter formed by the cascaded response of these two filter sections has a broad, octave bandwidth about the 150-Hz center frequency, with sharp skirts above and below 150 Hz that produce an attenuation factor of greater than 24 db for signal frequencies greater than 300 Hz and less than 75 Hz. The output signal from the bandpass filter is the 150-Hz carrier modulation signal that is produced due to the presence of a crack. All other frequency components that are present at the detector-demodulator output are removed by the filter. The filter output signal is coupled to the meter drive amplifier, IC5; the crack alarm level detector, IC6; and the negative peak detector, IC7.

Meter Amplifier

The meter drive amplifier and its associated circuitry perform the function of producing a current level that is proportional to the amplitude of the 150-Hz crack signal to drive the crack indication meter on the front panel of the instrument. The current level that is produced by this circuit is the rectified average of the 150-Hz crack signal. Amplifier IC5 is operated in a unity voltage gain configuration with the meter signal conditioning circuit inside the amplifier feedback loop. The amount of drive current that is sent to the meter is a function of the voltage across the resistor that is connected from pin 2 of IC5 to ground. The voltage at this point is the same as that at the input to this amplifier because of the

unity gain configuration. The resistor connected to pin 2 is one of the three resistors, R28, R29, and R30, with the proper resistor selected by the sensitivity selector switch on the instrument panel. The 150-Hz alternating current that is produced by the crack signal at this point is rectified by the diode bridge circuit composed of CR1, CR2, CR3, and CR4, and filtered by C19 to produce a constant current level proportional to the crack magnitude. Diodes CR5 and CR6 in this circuit provide overload protection for the meter, which is not shown on this schematic, but is in the circuit in parallel with capacitor C19. Potentiometer R25 is a circuit adjustment to compensate for the offset voltages produced by both IC5 and the filter output stage amplifier, IC4. This adjustment allows the meter circuit to be used with voltage levels in the tens of millivolts range with no offset inaccuracies.

CRACK ALARM CIRCUIT

The function of the crack alarm level detector circuit is to produce an audible alarm signal when the magnitude of the crack that is being observed by the rotating probe has exceeded a preset reference level. Amplifier IC6 is used in this circuit as a voltage comparator that determines when the level of the filter output signal has exceeded a reference voltage level. The reference level in this case is the wiper voltage on potentiometer R32 that has been set to just trip the alarm on a crack of a known magnitude. When a crack signal that exceeds the reference level is detected, the output of IC6 switches from a positive voltage level to a negative voltage level. This change in voltage level causes the state of transistors Q1 and Q2 to be changed from nonconducting to conducting. The current through transistor Q2 passes through the audible alarm unit and is returned to ground through diode CR13. This action turns on the audible alarm.

CRACK DIRECTION DETECTOR

The final circuit on circuit board no. 2 is the crack direction detector. The purpose of this circuit is to determine when a reference mark on the rotating probe is aligned with the direction of the crack being observed, and to indicate this condition by modulating the intensity of the audible alarm. This circuit is composed of amplifiers IC7 and IC8 and their associated circuitry and transistors Q3 and Q4. Amplifier IC7 in this circuit functions as a negative peak detector to determine the position in time of the negative peak of the 150-Hz output signal of the bandpass filter. The circuit operates in such a way that the signal coupled through capacitor C25 to pin 2 of IC7 has its negative peak clamped at ground potential by the action of IC7 through diodes CR9 and CR14.

The clamping action produces a positive pulse at pin 6 of IC7 each time a negative peak of the signal occurs. The negative peak is used as a reference in this case because it is indicative of the angular position of the rotating probe at which there is minimum interaction between the crack under observation and the magnetic flux from the probe coil. The timing of the negative peak of the 150-Hz signal is compared with the timing of a positive pulse from the output of amplifier IC8. The positive signal at pin 6 of IC8

is derived from a light reflective transducer in the housing of the rotating probe. A current pulse is produced at a once-per-revolution rate when this transducer observes a reflective element on the rotating portion of the probe. The circuit for the transducer is shown on drawing no. 10D000133.

Diode CR1 is a light-emitting diode that generates the light that is transmitted from the stationary portion of the probe to the rotating element. Transistor Q1 is a light-sensitive transistor that produces a pulse of current each time the reflective element passes in front of the emitter-receiver pair. Amplifier IC8 on board no. 2 acts as a current to voltage converter, the output of which changes state from a negative level to a positive level each time a current pulse is generated by Q1 in the probe. The position of the reflective element on the rotating probe, and the position of the reference mark on the outer case of the probe are chosen so that when the negative peak of the 150-Hz signal and the current pulse from the probe reflective transducer coincide in time, the reference mark indicates the direction of the crack under observation. The coincidence of these two signals is detected by the diode-transistor "AND" gate composed of diodes CR10, CR11, CR12, and transistor Q3. Transistor Q3 in this circuit is normally in a nonconducting state when the probe reference mark is not aligned with the crack direction. When the mark is aligned with the crack direction, the positive pulses that are at pin 6 of IC7 and pin 6 of IC8 at the same instant of time cause Q3 to be placed in a conducting state. The current through Q3 causes Q4 to saturate, which removes diode CR13 from the conduction path for the audible alarm current by reverse biasing the diode with minus 7.5 volts DC. The effect of Q4 conducting is that the level of the audible alarm signal is increased momentarily by a factor of almost two due to the increase of alarm current through Q4. Transistor Q4 is then turned off and on at a 75-Hz rate by the crack direction circuit, causing the audible alarm to have a change in output at this rate. This has the effect of modulating the alarm output at 75-Hz while the probe is aligned properly with the crack direction. It should be noted at this point that the crack direction circuit itself cannot cause an output from the audible alarm. The alarm level set by amplifier IC6 on board no. 2 must be exceeded before the alarm can turn on, and therefore, it is possible to determine the direction of only those cracks which have a magnitude greater than the alarm level.

BATTERY AND BATTERY CHARGER CIRCUIT

Power is supplied to the electronic circuitry from a rechargeable nickel-cadmium battery that is located underneath the two circuit boards in the system case. Supplied with the battery source is a charging circuit that can be operated from 115 volts AC. The charging circuit is designed so that the electronics system can be either on or off while the battery is being charged. Circuit operation is in no way affected by the battery's being in a charging mode, and the charging rate of the battery is not decreased when the circuit is on in this mode. Drawing no. 10D000133 shows the battery charger circuit, the battery connections, the front panel control wiring, and the circuit board interconnection wiring.

Power is provided to the battery charger circuit from the AC power source via transformer T1. This transformer steps the voltage down from 115 volts AC to 28 volts AC. Filter circuit FL1 in the primary of the transformer keeps any high noise that may be on the power line from affecting the operation of the circuit while the battery is in a charging mode. The secondary voltage from T1 is rectified by the diode bridge circuit composed of CR1, CR2, CR3, and CR4, and filtered by capacitor C3 to produce a low-ripple DC voltage. Since no switch is provided to remove the AC power from the charger circuit, a panel lamp is included to indicate when the rectified voltage produced from the AC line voltage is present.

The battery charger circuit consists of a constant current regulator that provides sufficient current to simultaneously charge the battery and operate the electronic circuits. The battery charging rate is sufficient to fully charge the battery overnight, yet low enough that the battery cannot be damaged by overcharging. The constant current source is composed of the drive transistor Q1, the current reference elements zener diode CR5 and resistor R2, and the blocking diodes CR7 and CR6. The latter components provide a conduction path for the charging current, but block the battery current from discharging through the current source when the charger circuit is not on. Switch S3 provides the path for power to the electronic circuits in its "on" position. When this switch is in its "off" position, it provides a path through resistor R4 for the charger current that would otherwise be used by the circuitry. In this way, the constant current source provides a constant battery charge current whether the electronic circuits are on or off.

CONCLUSIONS AND RECOMMENDATIONS

CONCLUSIONS

1. On standard fatigue specimens, crack indication was noted as early as 5% of the total fatigue life of the specimen.
2. The sensitivity of the probe showed a factor of two improvements over the best previous results.
3. Surface conditions such as paint, anodizing, grease, oil, and rough machine finish showed little or no effect on detecting microcracks.
4. The system showed relative insensitivity to standoff, tilt and surface condition. This is attributed to the use of a rotating probe.
5. The present probes work well on highly conductive nonpermeable metals in the as-designed condition.
6. Crack direction or orientation can be determined with the probe.
7. Redesign would be required for adaptation of the system to detect cracks in metals with lower conductivity than aluminum.
8. The basic design of a specific probe must be tailored to the required application.
9. The current configuration is limited to curvatures of 2 inches or greater.

RECOMMENDATIONS

1. For consideration as a general inspection tool, further development should be undertaken to incorporate particular requirements regarding metal properties, crack location, crack size, and surface topography.
2. For general purpose use, adjustment features should be developed to enable the probe to be adjusted to varying conditions and properties.