

IWL  
CR-07P71  
c. 1

TECHNICAL REPORT LWL-CR-07P71

MEASUREMENTS OF SPECTRAL CHARACTERISTICS OF SWIMMER  
TARGETS AND WATER RETURN CLUTTER

by

Aaron Galvin  
Aerospace Research, Inc.  
130 Lincoln Street  
Boston (Brighton), MA 02135

April 1974

Final Report

Contract DAAD05-72-C-0402

TECHNICAL LIBRARY  
BLDG. 305  
ABERDEEN PROVING GROUND, MD.  
STEAP-TL

APPROVED FOR PUBLIC RELEASE; DISTRIBUTION LIMITED

COUNTED IN

U. S. ARMY LAND WARFARE LABORATORY  
Aberdeen Proving Ground, Maryland 21005

20081001 155

IWL  
CR-07P71  
c. 1

The findings in this report are not to be construed as an official Department of the Army position unless so designated by other authorized documents.

UNCLASSIFIED

SECURITY CLASSIFICATION OF THIS PAGE (When Data Entered)

REPORT DOCUMENTATION PAGE		READ INSTRUCTIONS BEFORE COMPLETING FORM
1. REPORT NUMBER Technical Report LWL-CR-07P71	2. GOVT ACCESSION NO.	3. RECIPIENT'S CATALOG NUMBER
4. TITLE (and Subtitle) Measurements of Spectral Characteristics of Swimmer Targets and Water Return Clutter	5. TYPE OF REPORT & PERIOD COVERED Final Report	
	6. PERFORMING ORG. REPORT NUMBER	
7. AUTHOR(s) Aaron Galvin	8. CONTRACT OR GRANT NUMBER(s) DAADO5-72-C-0402	
9. PERFORMING ORGANIZATION NAME AND ADDRESS Aerospace Research, Inc. 130 Lincoln Street Boston (Brighton), MA 02135	10. PROGRAM ELEMENT, PROJECT, TASK AREA & WORK UNIT NUMBERS Task 07-P-71	
11. CONTROLLING OFFICE NAME AND ADDRESS US Army Land Warfare Laboratory Aberdeen Proving Ground, MD 21005	12. REPORT DATE May 1974	
	13. NUMBER OF PAGES 108	
14. MONITORING AGENCY NAME & ADDRESS (if different from Controlling Office)	15. SECURITY CLASS. (of this report) UNCLASSIFIED	
	15a. DECLASSIFICATION/DOWNGRADING SCHEDULE NA	
16. DISTRIBUTION STATEMENT (of this Report)  APPROVED FOR PUBLIC RELEASE; DISTRIBUTION UNLIMITED		
17. DISTRIBUTION STATEMENT (of the abstract entered in Block 20, if different from Report)  NA		
18. SUPPLEMENTARY NOTES  None		
19. KEY WORDS (Continue on reverse side if necessary and identify by block number)  Swimmer Detection Radar VHF L-Band		TECHNICAL LIBRARY BLDG. 505 ABERDEEN PROVING GROUND, MD. STEAP-TL
20. ABSTRACT (Continue on reverse side if necessary and identify by block number) This report describes work done by Aerospace Research, Inc. under Contract No. DAADO5-72-C-0402 with the USALWL to provide measurements of radar characteristics of targets (swimmers) and clutter (water surface) for use in the design of a swimmer detection radar system.  Doppler frequency recordings indicated that surface swimmers were detectable to a range of 30 feet or more with the CW radars at either 140 MHz or 915 MHz under calm surface conditions. However, under certain conditions, surface (CONT		

DD FORM 1473

1 JAN 73

EDITION OF 1 NOV 65 IS OBSOLETE

iii

UNCLASSIFIED

SECURITY CLASSIFICATION OF THIS PAGE (When Data Entered)

disturbances reduced the detection range to 10 feet or less. Underwater swimmers with SCUBA equipment were detectible only at close range (10-15 feet) and under calm conditions.

Pulsed operation resulted in a much higher signal-to-clutter ratio and permitted reliable detection of surface swimmers up to a 30-foot range with moderate surface activity (4 inch waves) and SCUBA equipped underwater swimmers at 30 feet under calm conditions. The signal-to-clutter ratio for the surface swimmer was sufficiently high to permit detections at several times the 30 foot range.

## SUMMARY

This report describes work done by Aerospace Research, Inc. under Contract No. DAADO5-72-C-0402 to the USALWL to provide measurements of radar characteristics of targets (swimmers) and clutter (water surface) for use in the design of a swimmer detection radar system.

Initial measurements were made using two CW doppler radars, one operating at 140 MHz and the other at 915 MHz. Spectral characteristics of clutter return and target return characteristics under various water surface conditions were recorded.

These tests included measurements under various conditions of no target, test target and swimmer target, calm conditions, moderately "choppy" conditions and strong surface motion conditions, as well as measurements in a river under calm and strong current and "choppy" conditions.

Doppler frequency recordings indicated that surface swimmers were detectable to a range of 30 feet or more with the CW radars at either 140 MHz or 915 MHz under calm surface conditions. However, under certain conditions, surface disturbances reduced the detection range to 10 feet or less. Underwater swimmers with SCUBA equipment were detectable only at close range (10-15 feet) and under calm conditions.

The most significant result of the CW measurements was that under all observed conditions the clutter spectra indicated a concentration of clutter return energy around a single frequency within the swimmer doppler band. The "peak frequency" was relatively insensitive to surface conditions while its amplitude was a direct function of surface activity. Similar results were obtained both at indoor (swimming pool) and outdoor (river bank) sites. Both radars provided similar data with the most repeatable results obtained at 915 MHz. The highest target-to-clutter ratio was produced using 915 MHz and vertical polarization.

Pulsed operation resulted in a much higher signal-to-clutter ratio and permitted reliable detection of surface swimmers up to a 30-foot range with moderate surface activity (4-inch waves) and SCUBA equipped underwater swimmers at 30 feet under calm conditions. The signal-to-clutter ratio for the surface swimmer was sufficiently high to permit detections at several times the 30-foot range but sensitivity limitation prevented experiments at the longer ranges.

AD-782127

## PREFACE

The radar measurements described in this report were done under LWL Task 07-P-71, Detection of Submerged Targets, as part of an investigation of the electromagnetic techniques applicable to the swimmer detection problem. A second report titled "Feasibility Study for an Underwater detections System" (Technical Report LWL-CR-07P71A, Apr 74) describes the investigations conducted with underwater equipment operating near the AM broadcast band.

The LWL Task Officers for this program were Mr. Louis V. Surgent, Jr., who supervised the radar testing described in this report and Mr. Thomas E. Olson, who supervised the underwater electromagnetic experiments.

## TABLE OF CONTENTS

<u>Section</u>	<u>Title</u>	<u>Page</u>
1.0	General Description and Summary of Results	1-1
2.0	Description of Measurement Equipment	2-1
2.1	140 MHz CW Radar	2-1
2.2	915 MHz CW Radar	2-2
2.3	915 MHz Pulsed Radar	2-2
2.4	Spectrum Analysis and Recording Equipment	2-5
3.0	Radar Measurements	3-1
3.1	Spectral Density Measurements	3-2
3.1.1	System Calibration	3-3
3.1.2	140 MHz CW Radar - Swimming Pool	3-4
3.1.3	915 MHz Radar - Swimming Pool	3-4
3.1.4	915 MHz Pulsed Radar - Swimming Pool	3-4
3.1.5	140 MHz CW Radar - Outdoor Test Site	3-4
3.1.6	915 MHz CW Radar - Outdoor Test Site	3-4
3.1.7	915 MHz Pulsed Radar - Outdoor Test Site	3-5
3.2	Test Target Calibration	3-5
3.3	Swimming Pool Target Detection Tests	3-6
3.3.1	140 MHz CW Radar Target Detection Tests	3-6
3.3.2	CW Radar Target Detection Tests	3-7
3.3.3	915 MHz Pulsed Radar Target Detection Tests	3-7
3.4	Outdoor Swimmer Detection Tests	3-8
4.0	Conclusions	4-1
4.1	Clutter Spectra	4-1

## TABLE OF CONTENTS

(continued)

<u>Section</u>	<u>Title</u>	<u>Page</u>
4.2	Target Returns	4-1
4.3	Observations	4-2
5.0	Selected Chart Recordings	5-1

## LIST OF FIGURES AND ILLUSTRATIONS

<u>Figure</u>	<u>Title</u>	<u>Page</u>
2-1	140 MHz CW Radar; Block Diagram	2-8
2-2	140 MHz Radar	2-9
2-3	Tri Loop Antenna	2-10
2-4	915 MHz CW Radar	2-11
2-5	915 MHz Radar	2-12
2-6	915 MHz Radar Antenna	2-13
2-7	915 MHz Pulsed Doppler Radar; Block Diagram	2-14
2-8	915 MHz Pulsed Radar	2-15
2-9	CW Radar Measurement System; Block Diagram	2-16
2-10	Radar Measurement System	2-17
2-11	Pulsed Radar Measurement System; Block Diagram	2-18
3-1	Charles River Test Site; Physical Layout	3-9
3-2	Charles River Test Site	3-10
3-3	Free Space Test Range; Physical Layout	3-11
3-4	Swimming Pool Test Site; Physical Layout	3-12
3-5	Swimming Pool Test Site	3-13
3-6	MIT Test Site	3-14

## LIST OF TABLES

<u>Table</u>		
I	Specifications for 140 MHz Measurements Radar	2-3
II	Specifications for 915 MHz Measurements Radar	2-4
III	Specifications for 915 MHz Pulsed Radar	2-6

## 1.0 GENERAL DESCRIPTION AND SUMMARY OF RESULTS

This report describes work done by Aerospace Research, Inc. under Contract No. DAAD05-72-C-0402 to provide measurements of radar characteristics of targets (swimmers) and clutter (water surface) for use in the design of a swimmer detection radar system.

Initial measurements were made using two CW doppler radars, one operating at 140 MHz and the other at 915 MHz. Spectral characteristics of clutter return and target return characteristics under various water surface conditions were recorded.

These tests included measurements under various conditions of no target, test target and swimmer target, calm conditions, moderately "choppy" conditions and strong surface motion conditions, as well as measurements in a river under calm and strong current and "choppy" conditions.

Based on the CW measurement results, it was clear that the size of a typical clutter cell had to be reduced in order to enhance the swimmer return-to-clutter ratio. Although this was not required under terms of the contract, ARI agreed to modify the 915 MHz CW radar for operation as a high-range-resolution pulsed system. The introduction of a high-resolution signal resulted in swimmer return-to-clutter ratios sufficiently high for automatic detection, although additional doppler processing would have to be added to the system to maintain this detection margin over a wide variety of water surface conditions.

In accordance with expectations, time on target limitations precluded recording of meaningful spectral data on moving targets, so target return information was recorded in the time domain sequentially with a variety of doppler filter settings.

Doppler frequency recordings indicated that surface swimmers were detectable to a range of 30 feet or more with the CW radars at either 140 MHz or 915 MHz under calm surface conditions. However, under certain conditions, surface disturbances reduced the detection range to 10 feet or less. Underwater swimmers with SCUBA equipment were detectable only at close range (10-15 feet) and under calm conditions.

The most significant result of the CW measurements was that under all observed conditions the clutter spectra indicated a concentration of clutter return energy around a single frequency within the swimmer doppler band. The "peak frequency" was relatively insensitive to surface conditions while its amplitude was a direct function of surface activity. Similar results were obtained both at indoor (swimming pool) and outdoor

(river bank) sites. Both radars provided similar data with the most repeatable results obtained at 915 MHz. The highest target-to-clutter ratio was produced using 915 MHz and vertical polarization.

Pulsed operation resulted in a much higher signal-to-clutter ratio and permitted reliable detection of surface swimmers up to a 30 foot range with moderate surface activity (4 inch waves) and SCUBA equipped underwater swimmers at 30 feet under calm conditions. The signal-to-clutter ratio for the surface swimmer was sufficiently high to permit detections at several times the 30 foot range but sensitivity limitation prevented experiments at the longer ranges.

Detailed description of the equipment procedures and recorded data are contained in the following sections of this report.

## 2.0 DESCRIPTION OF MEASUREMENT EQUIPMENT

The initial experiments of the program were carried out using two CW doppler radars, the first operating at 140 MHz and the second operating at 915 MHz. The choice of this equipment was based on ARI's previous experience with measurements using this type of equipment, the relative simplicity of the radars and required auxilliary equipment, and the availability of operating hardware. This equipment proved to be effective for accumulating data on the spectral distribution of signal returns from the water surface under various wind and wave conditions. The data from these measurements are included in Section 5 of this report.

The results of tests for detection capability using both a calibrated test target and swimmers indicated that the target signal-to-clutter return ratio was sufficient to provide only marginal automatic detection capability with either CW radar. Discrimination based on doppler frequency alone was not possible since the clutter spectrum peaked in the target doppler frequency band.

The automatic detection capability of the 915 MHz radar was greatly improved by converting it to a high range resolution (approximately 5 feet) pulsed radar. The pulsed system provided more reliable detection of swimmers as shown in the data section. No attempt was made to convert the 140 MHz system to pulsed operation since adequate range resolution could not be achieved at this frequency.

Spectral analysis of clutter return was accomplished by passing the radar doppler signal through a voltage controlled bandpass filter whose center frequency was swept slowly across the doppler band. The filter output was recorded as a function of frequency on an X-Y plotter.

Target returns were plotted as a function of time on a strip chart recorder.

Detailed descriptions of the radars and recording equipment are included in the following paragraphs.

### 2.1 140 MHz CW RADAR

Figure 2-1 shows a block diagram of the 140 MHz CW radar. RF energy is produced in a 140 MHz crystal controlled source. After bandpass filtering, the RF signal is divided in  $90^\circ$  hybrid, half the energy for transmission and half for use as a coherent local oscillator signal. The transmitted signal passes through a second  $90^\circ$  hybrid which acts as a duplexer to the single transmit/receive antenna of the system. The receiver output of the duplexing hybrid is fed through another  $90^\circ$  hybrid to a pair of quadrature mixers whose local oscillator signals are supplied through a  $0^\circ$  power divider. This power divider receives its input from the source power

divider hybrid. The outputs of the two quadrature mixers are sent to a balanced processor which provides high stable gain, performs the audio single-sidebanding operation, and provides doppler output signals.

The antenna used with the 140 MHz radar is a tri-loop array shared for simultaneous transmit and receive operation. It has a gain of approximately 12 dB.

Specifications of the 140 MHz radar are summarized in Table I and photographs of the radar and antenna are shown in Figures 2-2 and 2-3.

## 2.2 915 MHz CW RADAR

Figure 2-4 shows a block diagram of the 915 MHz CW radar. RF energy is generated in a 915 MHz cavity source. RF signal processing is accomplished in a stripline front end. A  $90^\circ$  hybrid splits the RF power and supplies half to the transmit antenna and half to a second  $90^\circ$  hybrid whose outputs provide the coherent local oscillator signals for a pair of quadrature mixers. The received signal reaches the mixers through a  $0^\circ$  power divider. In this system, because of the relatively small size of the antennas involved, an antenna which has separate isolated transmitting and receiving sections is utilized.

The outputs of the mixers are applied to the balanced signal processor through parallel amplifier-attenuator channels. The processor provides doppler band limiting, performs the audio single sidebanding function, and produces incoming and outgoing doppler signals.

Table II summarizes the characteristics of the 915 MHz CW radar. Figures 2-5 and 2-6 show the RF circuits, processor and antenna assembly of the radar.

## 2.3 915 MHz PULSED RADAR

Figure 2-7 shows a block diagram of the 915 MHz pulsed radar. Much of the circuitry is identical to that used in the 915 MHz CW radar. The source and the stripline front end are the same. The CW transmitter signal is fed to port #1 of a ferrite circulator. This energy exits through port #2, passes through an RF switch, normally in its minimum attenuation state, and is dissipated in a dummy load. The RF switch is activated at a 1 MHz repetition rate with a 20 nsec duration pulse. During the pulse the switch produces a short circuit across its input port and the RF energy

TABLE I

## SPECIFICATIONS FOR 140 MHz MEASUREMENTS RADAR

<u>Item</u>	<u>Specification</u>
Type of radar	Coherent doppler with homodyne quadrature detection
Operating frequency	140 MHz
Modulation	Continuous wave
Average output power	20 milliwatts
Receiver gain (max)	110 dB
Signal processing	Balanced, non-adaptive, single velocity band
Antenna	Single tri-loop antenna shared for transmit and receive; gain= 12 dB
Prime power input	+24, +6, -6 Vdc
Size	10-1/4" x 12" x 4" high
Weight	9 lbs.

TABLE II

## SPECIFICATIONS FOR 915 MHz MEASUREMENTS RADAR

<u>Item</u>	<u>Specification</u>
Type of radar	Coherent doppler with homodyne quadrature detection
Operating Frequency	915 MHz
Modulation	Continuous wave
Average output power	150 milliwatts
Receiver gain (max)	90 dB
Signal processor	Balanced, non-adaptive, single velocity band
Antenna	Dual antenna, each a monopole plus three-plane reflector. One used for transmit, one for receive; gain = 8 dB
Prime power input	16 Vac obtained from plug in transformer from 115 Vac
Size	9-3/4" x 14-3/4" x 3-1/4" high
Weight	13 lbs.

is reflected back into port #2 of the circulator. The reflected energy exits from port #3 of the circulator and is transmitted via the antenna.

The received signal is processed in the quadrature mixers and the resulting video signals are range gated in dual sample and hold circuits to provide audio signals for the balanced signal processor. Range gate position is established by passing the rep rate pulse through a fixed cable delay line to the sample and hold circuits.

Table III summarizes the characteristics of the pulsed radar. Figure 2-8 shows the major components of the system.

## 2.4 SPECTRUM ANALYSIS AND RECORDING EQUIPMENT

Figure 2-9 shows a block diagram of the measurement system for spectrum analysis and target return recording with the CW radars. Spectrum analysis is accomplished by passing the amplified radar output signal through a band pass voltage controlled filter made up of separate low pass and high pass filters whose cutoff frequencies are proportional to an input control voltage. The control characteristics of the filters are designed to track in frequency so that the combination acts as a band pass. The useful dynamic range of the filters is on the order of 60 dB and the selectivity is 18 dB per octave. The tuning range covers two decades and the frequency varies linearly with control voltage. The frequency resolution of the bandpass filter is better than one octave and the "Q" is constant over the tuning range.

Spectral density of the radar return signal is plotted directly in dB vs. log frequency on an X-Y recorder. A linear ramp generator produces a sweep signal with a period of several minutes duration. The linear sweep is applied directly to the X drive of the recorder and through an exponential amplifier to the control inputs of the filter. The filter output is rectified in a precision detector and applied to the Y input of the recorder through a logarithmic amplifier to produce a plot directly in dB which displays the full 60 dB dynamic range of the system.

The measurement system also includes a multi-channel strip chart recorder for direct recording of doppler signals from the radar, a digital voltmeter for monitoring various system parameters, a precision voltage source for recorder calibration, system power supplies, and a 1.5 KVA portable alternator for field operation. A photograph of the system is included in Figure 2-10.

The measurement system was modified somewhat for use with the pulsed radar as shown in the block diagram, Figure 2-11. The major

TABLE III

## SPECIFICATIONS FOR 915 MHz PULSED RADAR

<u>Item</u>	<u>Specification</u>
Type of radar	Pulsed coherent doppler with homodyne quadrature detection
Operating frequency	915 MHz
Modulation	20 nsec pulse at 1 MHz rate
Peak output power	150 milliwatts
Receiver gain (max)	90 dB
Signal processor	Balanced, non-adaptive, single velocity band
Antenna	Dual antenna, each a monopole plus three-plane reflector. One used for transmit, one for receive; gain approx. 8 dB
Range	Determined by fixed delay line nominally set to 20 feet
Prime power input	+9, -9 Vdc

change was the addition of a second filter set to permit simultaneous band limiting in both incoming and outgoing doppler channels of the radar processor.

## 2.5 TEST TARGET

A standard test target was employed as a reference for all radar measurements. The target consists of a polystyrene foam sphere with an aluminum foil surface. The 18 inch diameter of the target was selected to give a radar cross section approximately equal to the optical cross section at both 140 MHz and 915 MHz. The calculated cross section is 1.75 feet<sup>2</sup> or 0.164 m<sup>2</sup>. The target weighs 10.5 lbs. and floats with more than 90% of its volume above the water surface.

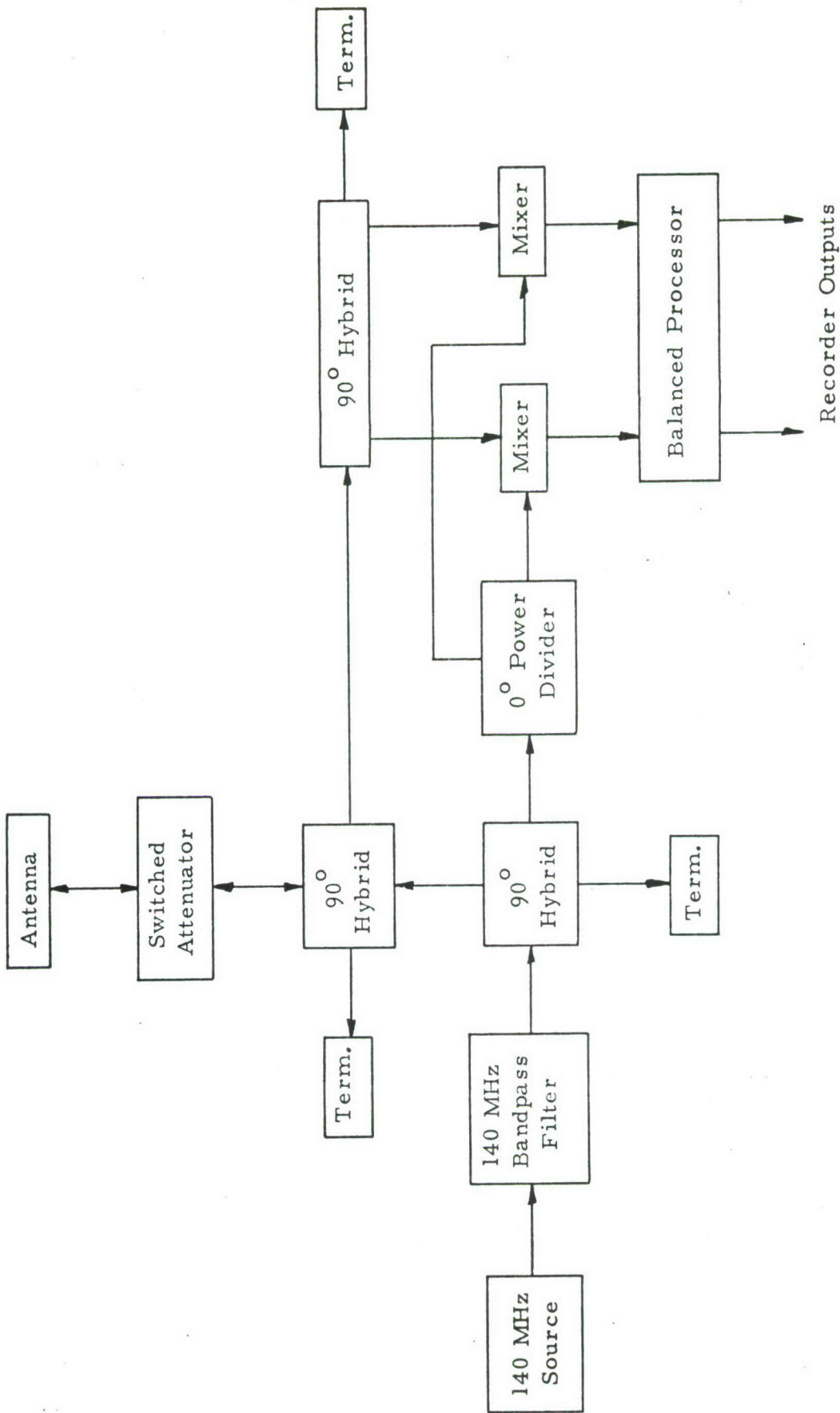


Figure 2-1 140 MHz CW Radar  
Block Diagram

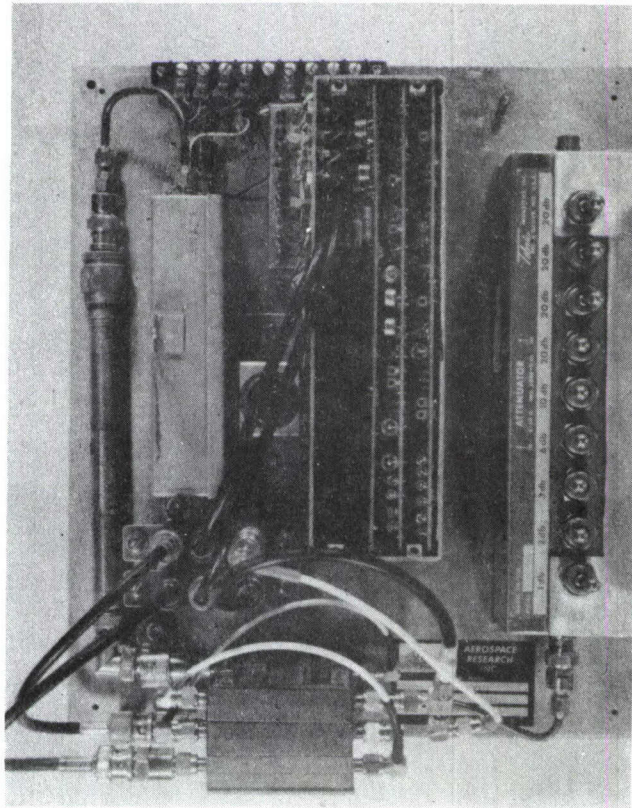


Figure 2-2 140 MHz Radar

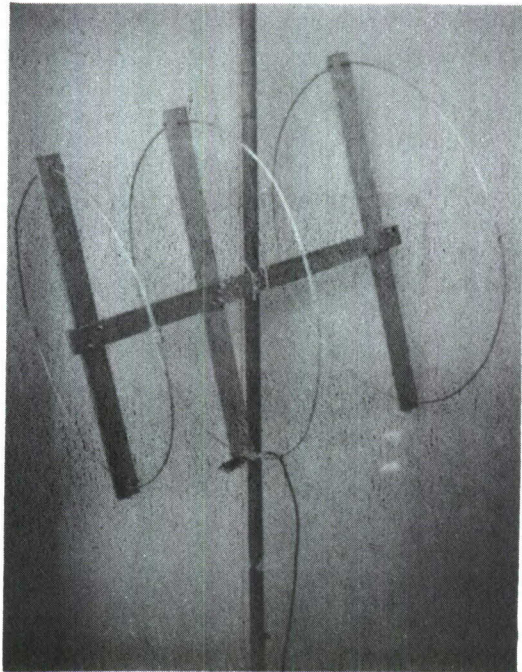


Figure 2-3 Tri Loop Antenna

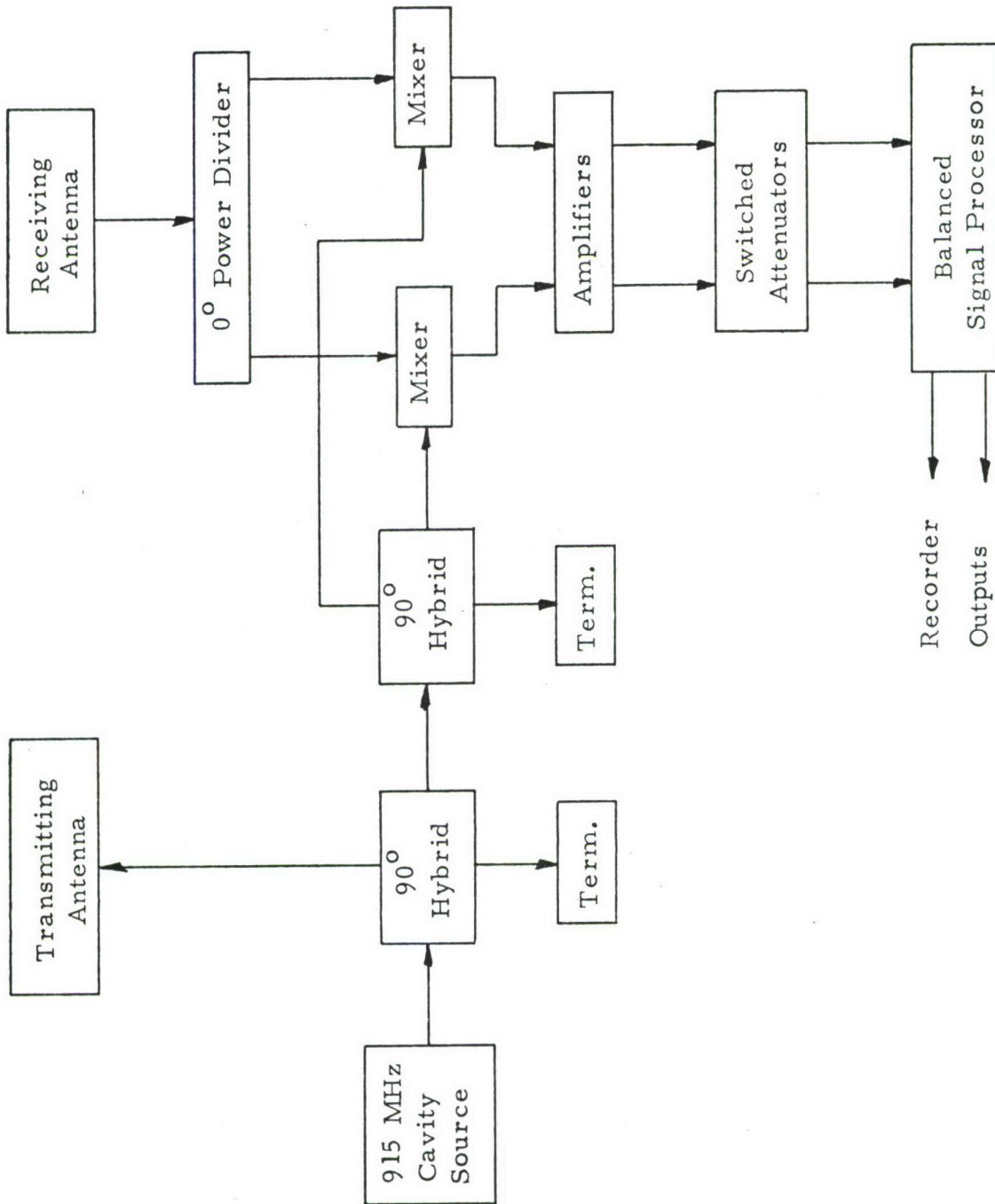


Figure 2-4 915 MHz CW Radar

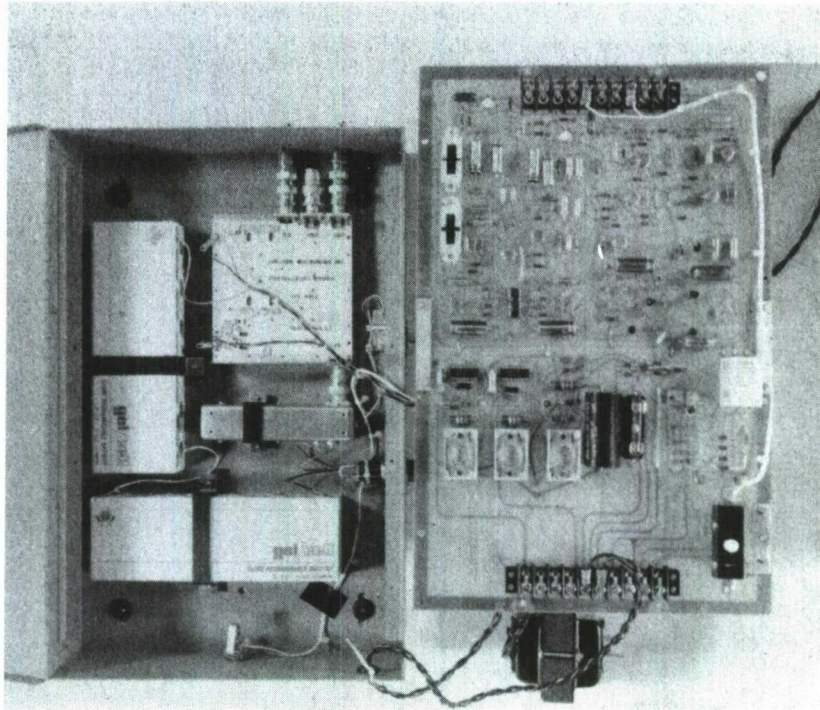


Figure 2-5 915 MHz Radar

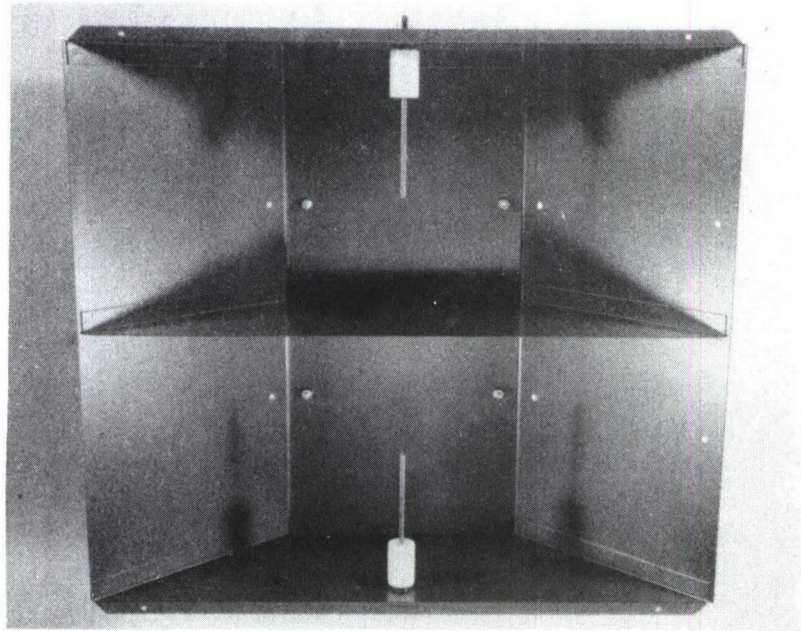


Figure 2-6 - 915 MHz Antenna

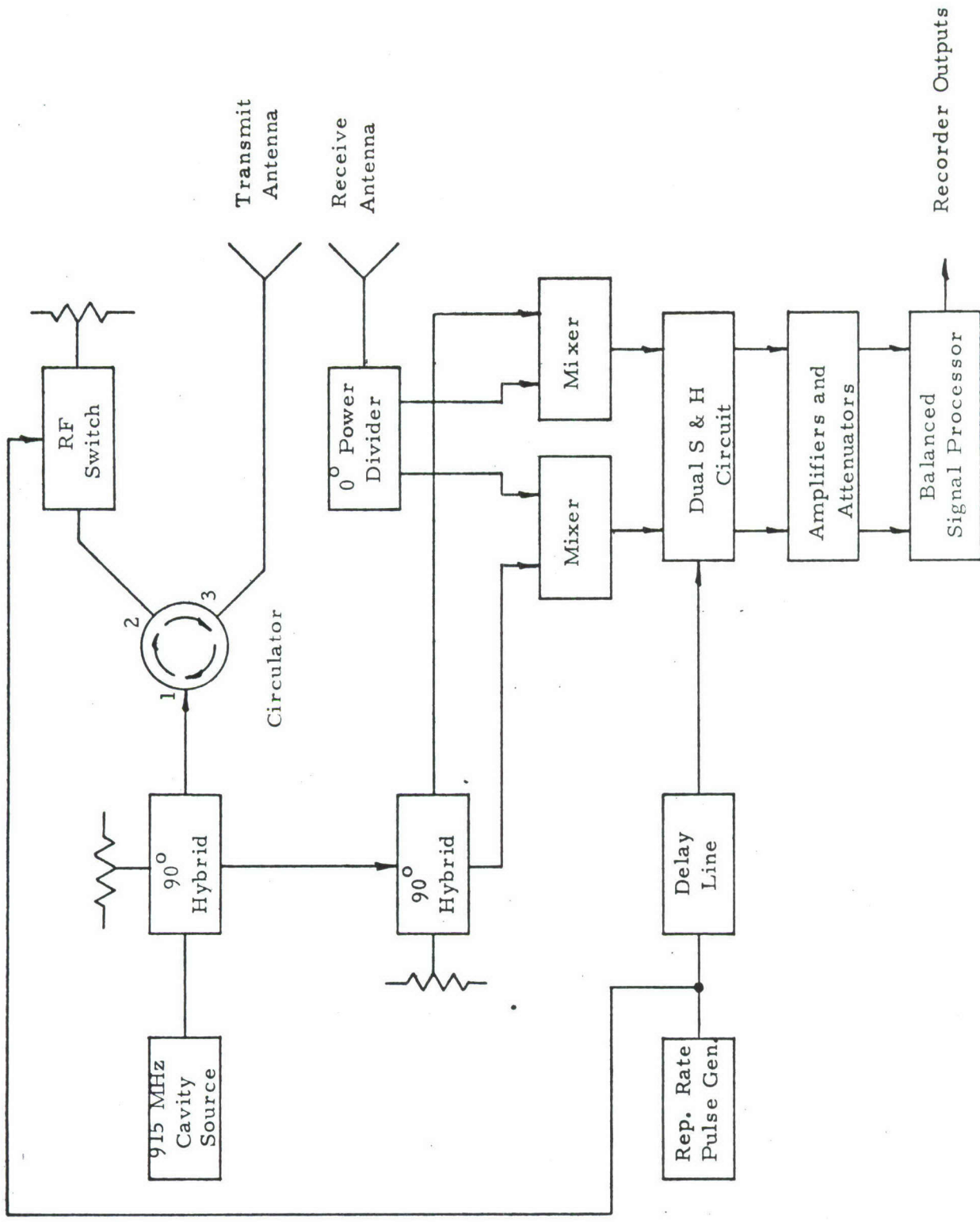


Figure 2-7 - 915 MHz Pulsed Doppler Radar  
Block Diagram

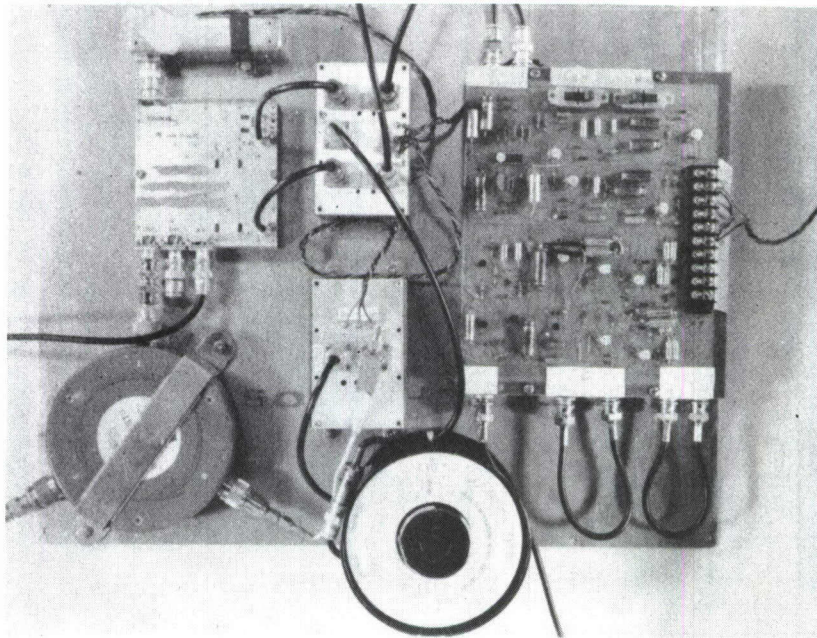


Figure 2-8 - 915 MHz Pulsed Radar

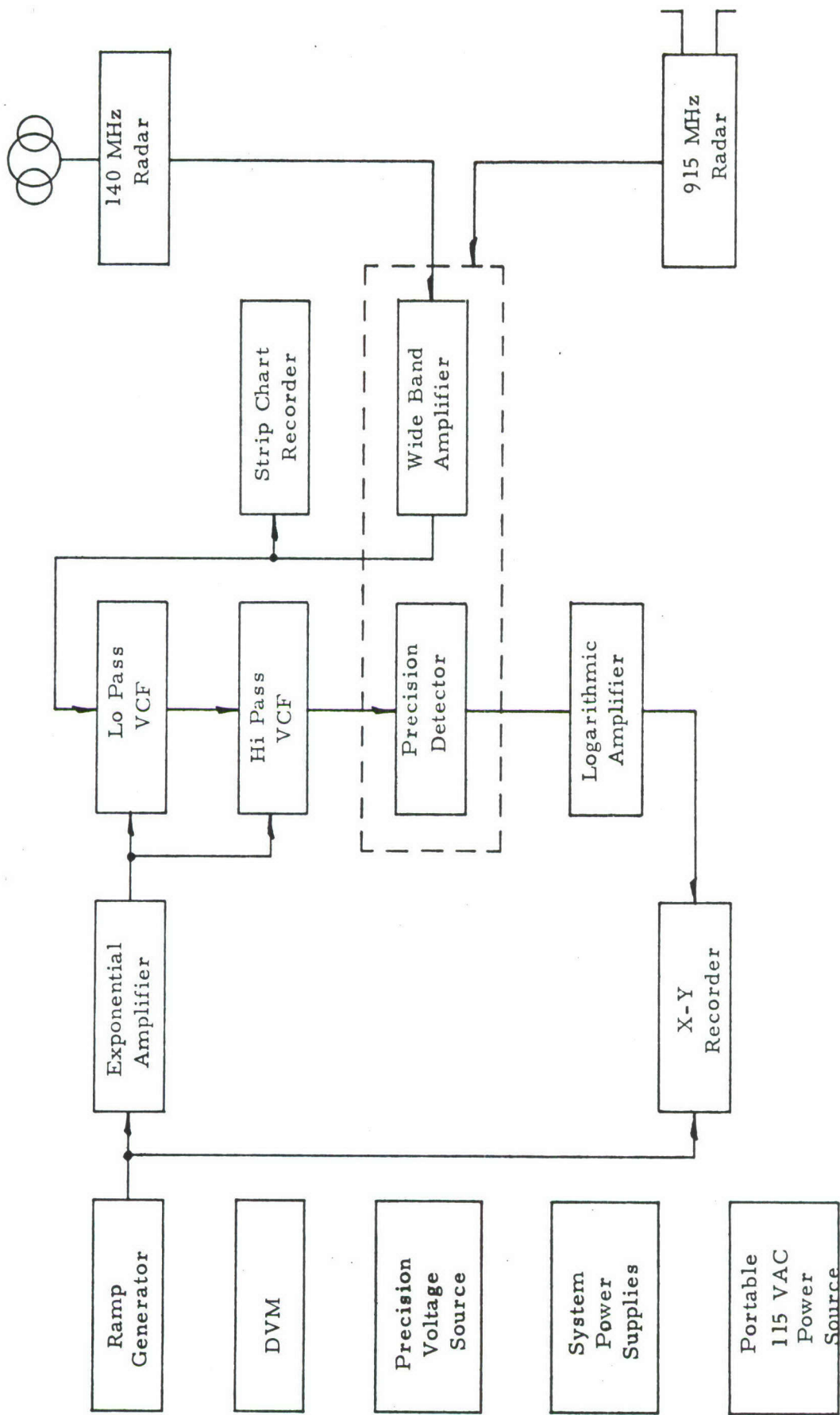


Figure 2-9 - CW Radar Measurement System  
Block Diagram

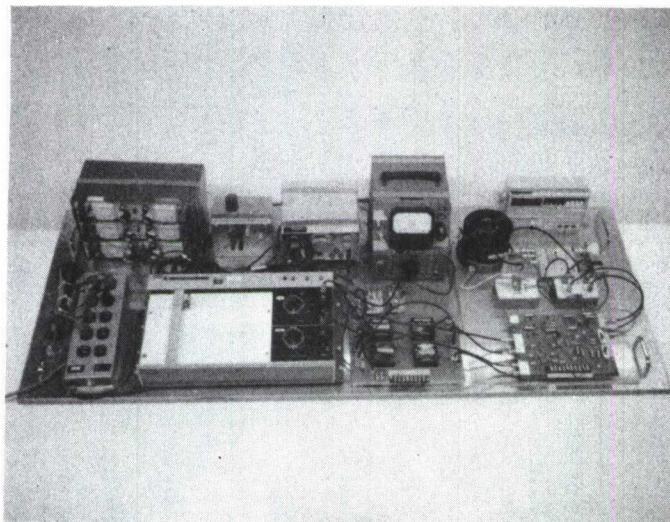


Figure 2-10 - Radar Measurement System

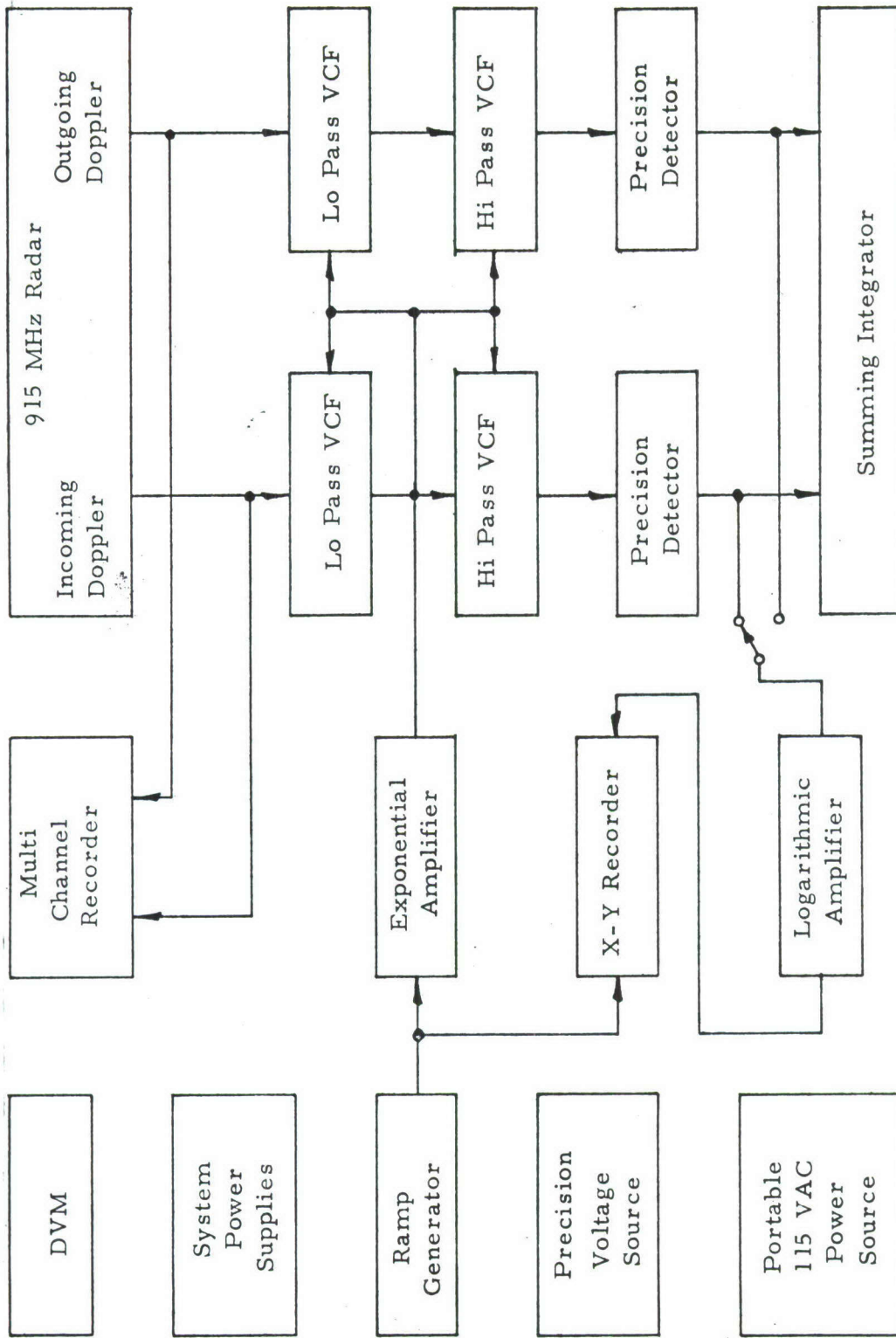


Figure 2-11 - Pulsed Radar Measurement System

Block Diagram

### 3.0 RADAR MEASUREMENTS

Three basic types of measurements were made using both CW and pulsed radars. The first type consisted of spectral density plots of clutter return from water surfaces under various conditions of wind and wave activity. The second type of measurement consisted of signal return amplitude vs. time recordings from an 18 inch diameter spherical test target moving radially with respect to the radar antennas while suspended in free space from a wire and also towed on the water surface. The third type of measurement consisted of signal return amplitude vs. time recordings from swimmers moving radially with respect to the radar antennas both with and without SCUBA equipment.

Outdoor measurements of clutter spectra were made at a test site along the Charles River in Brighton, Massachusetts. A diagram and photograph of the area are shown in Figures 3-1 and 3-2. The antenna was placed at the waters edge in an area free of vehicular and pedestrian traffic. Vegetation in the immediate vicinity of the radar was limited to low growing brush. The clear water area extended well beyond the radar range for almost  $180^{\circ}$  in azimuth.

A second test site used for calibration of the measurement system using the test sphere target in a "free space" environment is shown in Figure 3-3. The target was suspended from a trolley which ran on a wire stretched between two trees. The radar antenna was mounted near one end of the wire and pointed along the target path. The target path was 8-10 feet off the ground. The target was manually towed along the wire.

Indoor test target tow tests and swimmer tests were conducted at the Boys Club swimming pool in Waltham, Massachusetts. Figures 3-4 and 3-5 show the test setup at the pool. The radar antenna was positioned six feet above the water surface and was directed across the pool with its line of sight pointed at the water surface at the midpoint of the pool. The test target was manually towed on the water surface along the antenna line of sight using a pulley and line arrangement which kept the operator out of the antenna beam. During swimmer detection tests, the swimmer moved along the same path.

A random wave pattern was generated in the pool by disturbing the water surface in one corner of the pool. Multiple reflections from the sides of the pool produced waves with amplitudes up to 4 inches in height.

Outdoor swimmer detection tests were conducted at the Massachusetts Institute of Technology Boathouse on the Charles River in Cambridge, Massachusetts. The radar was located on the boathouse dock with the antenna

directed at the water surface 30 feet from the dock as shown in Figure 3-6. The swimmer and test targets moved along a line extending from the antenna to a piling about 60 feet out from the edge of the dock.

### 3.1 SPECTRAL DENSITY MEASUREMENTS

Clutter return spectra were recorded using the 140 MHz CW radar, the 915 MHz CW radar, and the 915 MHz pulsed radar, both at the Charles River test site and at the swimming pool. All the spectra show a general similarity in character. The common features are shown in Figure 3-7. The doppler band for a target velocity range of .25 to 10 feet per second extends from 0.07 Hz to 3.0 Hz for the 140 MHz radar and from 0.5 Hz to 20 Hz for the 915 MHz radar. All the spectra exhibit a low density at the high end of the doppler band. At the lower frequencies the density builds up to a peak value, then decreases again at the low end of the band. The peak frequency appears to be relatively independent of water surface condition. The amplitude of the peak is a direct function of the water surface activity. For the 140 MHz radar the peak frequency occurs at about 1.0 Hz which is equivalent to a target velocity of 3.5 feet/second. The 915 MHz peak occurs at about 2.0 Hz which corresponds to a 1 foot/second target velocity. The maximum wave amplitude was about 4 inches at both the indoor and outdoor sites. At the indoor site wave motion appeared random, that is, no net phase velocity in any direction was observed. At the outdoor site, with wind velocity of 15-20 mph, the waves traveled along the water surface at 1 to 2 feet/second in the direction of the wind velocity. At 915 MHz the peak in the doppler spectrum corresponds fairly well to this velocity. At 140 MHz the doppler peak occurred at about 3 times the frequency corresponding to this velocity. The difference may be accounted for by the fact that at 915 MHz the transmitted wave length (1.08 feet) was equal to or less than the distance between successive wave peaks (1 to 2 feet), whereas at 140 MHz one wave length (7.04 feet) bracketed several water surface waves.

In general the data taken at 915 MHz was much more repeatable than at 140 MHz. The available equipment allowed only one channel to be plotted at a time with 3 to 10 minutes required for a complete sweep. At 915 MHz the spectra repeated to within 3 to 6 dB on successive runs so comparative plots for incoming and outgoing channels were possible. These plots indicated a definite net velocity component in the case of wind blown surface waves. At 140 MHz the poor repeatability of the spectra did not permit direct comparison of incoming and outgoing channels.

The existence of a clutter spectrum peak within the range of likely swimmer target velocities which is independent of the magnitude of wave activity rules out the possibility of a simple adaptive filtering technique for signal to noise enhancement, such as is possible in the case of clutter return from wind blown foliage where the clutter spectrum amplitude is monotonic with frequency. Also the net velocity component of the clutter from wind blown waves reduces the effectiveness of balanced processing for target to clutter discrimination. These results along with the target return measurements described below led to the conclusion that the reduction of clutter cell size would be the most effective approach for signal to clutter improvement. For this reason the 915 MHz radar was modified to provide high range resolution capability by converting it to a pulsed system. Clutter spectra recorded with the pulsed radar correlated very well with the CW results, and target detection capability was markedly improved.

The spectral data recorded in this program are included in Section 5. The following paragraphs describe the conditions for each experiment.

### 3.1.1 System Calibration (Figures 5-1 through 5-4)

Figure 5-1 shows the inherent noise output level in the 140 MHz CW system with the antenna replaced with a dummy load. Figure 5-2 is a similar plot of the 915 MHz CW radar. Figure 5-3 shows the noise from the 915 MHz pulsed radar under the same conditions. Figure 5-4 shows the amplitude vs. frequency response and resolution capability of the spectrum recording system. Four equal amplitude sinusoidal signals were injected at the system input on successive frequency sweeps. The 18 dB per octave slope of the voltage tunable filters is apparent from these traces.

### 3.1.2 140 MHz CW Radar - Swimming Pool (Figures 5-5 through 5-8)

Figure 5-5 is the spectrum recorded using vertical polarization with minimum disturbance of the water surface. A very small residual surface wave motion was present from previous activity in the pool. A discernable peak is located at 1 Hz. Figure 5-6 is the response using horizontal polarization under the same conditions. Figures 5-7 and 5-8 show the effects of random surface waves for vertical and horizontal polarizations. The vertical response exhibits a strong peak at 1 Hz while the horizontal response peaks less and has lower amplitude across the band.

### 3.1.3 915 MHz CW Radar - Swimming Pool (Figures 5-9 through 5-14)

Figures 5-9 and 5-10 are the vertical and horizontal spectral responses of the 915 MHz CW radar under quiet water conditions. The clutter return builds up gradually toward the low end of the doppler band but no peak is visible. Figures 5-11 and 5-12 show the vertical and horizontal returns from random wave motion in the pool. Both exhibit sharp peaks between 1 and 2 Hz indicating a narrow band of clutter. Figures 5-13 and 5-14 show the vertical and horizontal spectra under similar wave conditions. The incoming and outgoing channels of the radar processor are plotted separately in these experiments. Very little difference is apparent between incoming and outgoing signals and both horizontal and vertical spectra peak in the 1-2 Hz region.

### 3.1.4 915 MHz Pulsed Radar - Swimming Pool (Figures 5-15 and 5-16)

Figures 5-15 and 5-16 show the clutter return from surface wave motion as measured by the high resolution pulsed radar. The peak in the spectra occurs at 2-3 Hz in these experiments and the vertical return is 20 dB greater in amplitude than the horizontal. There is no significant difference between the incoming and outgoing signal processor channel outputs.

### 3.1.5 140 MHz CW Radar - Outdoor Test Site (Figures 5-17 through 5-19)

Figures 5-17, 18 and 19 show 140 MHz clutter return spectra from surface waves recorded at the outdoor test site described in Section 3 and illustrated in Figure 3-1. Figure 5-17 was recorded with the antenna directed into a 10-15 MPH wind. The shape of the trace is very similar to that recorded at the indoor swimming pool. Figures 5-18 and 5-19 indicate the poor repeatability experienced with the 140 MHz measurements. Three consecutive traces were recorded for both vertical and horizontal polarizations. Disregarding the transient effects of passing boats there is nevertheless a 10 to 15 dB spread in amplitudes over much of the doppler band. The general character of the spectra is repeated, however, with a peak in the 1-2 Hz region. The third horizontal polarization trace (Figure 5-19), recorded during a calm period, shows no peak in the response curve.

### 3.1.6 915 MHz CW Radar - Outdoor Test Site (Figures 5-20 through 5-31)

These spectra were recorded at the outdoor test site on several different days and differing wind and water conditions. As in the preceding

data, there is a definite similarity among all the recordings. A peak appears in 2 to 3 Hz region in most cases. The peaks from vertically polarized signals tend to be sharper and somewhat higher in amplitude than those from horizontal signals. Figures 5-20 and 21 were taken with the antenna pointed directly into the wind with surface waves approaching at 1-2 feet per second. Wind velocity was 15 to 20 mph. Figures 5-22 and 23 were taken with the antenna pointed 45° off the wind with wind velocity estimated at 20-25 mph. Figures 5-24 and 5-25 were taken with the antenna directed across the wind at 20 to 25 mph. Figures 5-26 through 5-29 were taken on another day with 20-25 mph winds. Figures 5-26 and 27 were taken with the antenna pointed directly into the wind, and Figures 5-28 and 29 were taken across the wind. Figures 5-30 and 31 were taken on another occasion at the same site with light winds, 10-15 mph. Two traces were recorded in succession for each polarization and these show that the spectra are repeatable.

### 3.1.7 915 MHz Pulsed Radar - Outdoor Test Site (Figures 5-32 through 5-35)

A series of tests to examine the spectra of approaching and receding waves using the 915 MHz pulsed radar are recorded in Figures 5-32 through 5-35. Both the incoming and outgoing channels of the balanced signal processor are plotted for both vertical and horizontal polarizations. The approaching and receding waves are clearly separated by the balanced processing in the vertical polarization cases. In the horizontal polarization plots the peak amplitude is quite low and there is much less resolution of incoming and outgoing waves.

### 3.2 TEST TARGET CALIBRATION (Figures 5-36 through 5-38)

Figures 5-36, 5-37 and 5-38 show the results of test target radar calibration tests conducted at the test range described in Section 3 and shown in Figure 3-2. Incoming and outgoing radar processor output signals were recorded for vertical and horizontal polarizations in each radar configuration. The purpose of the tests was to establish the amplitude vs. range characteristics for each radar working against a target of known cross section in an environment free of water surface reflections. As the recordings indicate, however, there is evidence of considerable multipath return particularly in the horizontal polarization mode. Figure 5-36 shows the results of tests with the 140 MHz CW radar. The returns in both vertical and horizontal polarization fail to drop off according to the fourth power law. There is also considerable crosstalk between incoming and outgoing processor signals. These results indicate considerable multipath return

for both polarizations. Figure 5-37 shows results of an identical series of tests using the 915 MHz CW radar. In the vertical mode the returns are about as expected with rapid fall-off with increasing range. For horizontal polarization, multipath returns, probably from the ground surface, extend the response to greater than expected range. With this radar, crosstalk between incoming and outgoing processor channels is minimal. Figure 5-38 shows the target returns as measured on the 915 MHz pulsed radar. The range gate is centered at 20 feet and its width is about 5 feet. There is some evidence of multipath return in the horizontally polarized signal which shows multiple peaks and is almost 6 dB greater in amplitude than the vertical signal.

### 3.3 SWIMMING POOL TARGET DETECTION TESTS

Tests of detection capability against various targets were conducted with the 140 MHz CW radar, the 915 MHz CW radar and the 915 MHz pulsed radar at the swimming pool test site. The targets included the 18 inch test sphere towed on the surface, unaided swimmers on and below the surface, and SCUBA equipped swimmers on and below the surface. In all tests the target moved radially along the radar line of sight as shown in Figure 3-3. Disturbance of the water surface by target motion was minimized to achieve the most favorable target to clutter return ratio. Separate clutter return recordings were made with the water surface agitated to permit estimation of detection capability under high clutter conditions.

#### 3.3.1 140 MHz CW Radar Target Detection Tests (Figures 5-39 through 5-41)

Figure 5-39 shows the returns from the test sphere towed back and forth on the water surface for both vertical and horizontal polarization. The nearest target position was about ten feet from the antenna and the farthest was about forty feet. The vertical return was about 6 dB greater in amplitude than the horizontal return. Figure 5-40 shows the returns from a swimmer under similar conditions. Only the swimmer's head was above the water surface and he used the breaststroke to minimize water disturbance. The upper traces on the recording are to the same scale as the corresponding sphere return in the previous tests. The lower traces are amplified and narrow banded. Although a doppler return from the swimmer is visible, the signal to clutter ratio is not adequate for reliable automatic detection. Filtering the returns did not significantly improve the ratio. Figure 5-41 shows the returns from clutter only at 140 MHz. The vertical return is about 12 dB greater than the horizontal return and about equal in amplitude to the maximum sphere return at close range. Detection of the sphere under this clutter condition is doubtful.

### 3.3.2 915 MHz CW Radar Target Detection Tests (Figures 5-42 through 5-44)

Figure 5-42 shows the returns from the test sphere towed on the water surface with minimum surface disturbance. The signal to clutter ratio is one at about a 30 foot range. The null in the vertical response is probably a multipath phenomenon since this did not appear in the "free space" test (Figure 5-37). Figure 5-43 shows the returns from a swimmer with only his head above the water surface and disturbing the water as little as possible. The clutter level is increased by about 6 dB by the swimmers activity and the target return is 6 to 10 dB less than for the sphere. Figure 5-44 shows clutter return from the agitated water surface plotted to the same scale as the target returns. Note the narrow band character of the clutter signal. Detection of the sphere at this clutter level would be marginal and detection of a swimmer would not be possible.

### 3.3.3 915 MHz Pulsed Radar Target Detection Tests (Figures 5-45 through 5-50)

Figure 5-45 shows the returns from the 18" test sphere towed on the water surface. The vertical returns correlate very well both in amplitude and pulse shape with the "free space" return shown in Figure 5-38. The horizontal trace exhibits somewhat less multipath effect than the "free space" horizontal return. The water surface was smooth during these tests. The range gate was set at 20 feet. Figure 5-46 shows the returns from a swimmer with only his head above the water surface. The vertical returns are 6 dB lower in amplitude than the test sphere returns. The horizontal returns are about 15 dB below the test sphere returns and only about 6 dB above the clutter level. Figure 5-47 shows the results from underwater swimmer tests. For these experiments the swimmer moved about 2 feet beneath the surface. A very slight target indication is visible in the vertical return but nothing is detectable in the horizontal return. Figure 5-48 shows the returns from a swimmer equipped with a single air tank moving on the water surface. The amplitude of the returns varied with the aspect of the tank with reference to the antenna. The maximum was equal to the test sphere return and the minimum was about equal to the unequipped swimmers return. Figure 5-49 shows the return from the tank equipped swimmer moving 2 feet beneath the water surface. The swimmer is clearly visible in the vertical return but does not appear in the horizontal return. Figure 5-50 is a recording of the clutter return from the water surface with random wave motion with about 4 inch maximum amplitude. The vertical clutter return is about half the amplitude of the peak target

sphere return and equal to the unequipped swimmer return. The horizontal clutter return is similarly related to horizontal target returns although much lower in amplitude than the vertical clutter return.

#### 3.4 OUTDOOR SWIMMER DETECTION TESTS (Figures 5-51 through 5-56)

Target detection tests were conducted at the MIT test site (Figure 3-6) using both the test sphere and a SCUBA equipped swimmer. Data were obtained using both the 915 MHz pulsed radar and the 915 MHz CW radar. The range gate position in the pulsed measurements was changed to 30 feet for these tests. The water surface was calm for all tests.

Figure 5-51 shows the vertically polarized test sphere return as measured by the pulsed radar. Figure 5-52 shows surface swimmer returns in vertical and horizontal polarization. System calibration was unchanged during this test series. The vertical return from the SCUBA equipped surface swimmer is only slightly smaller in amplitude than the test target return.

Figure 5-53 shows the returns from the swimmer moving 2-3 feet below the water surface. The target appears only in the vertical polarization. The outgoing target return is stronger probably because of the larger air tank cross section displayed to the radar in this swimmer orientation. Some water surface disturbance in the vicinity of the swimmer was caused by SCUBA exhaust.

Figure 5-54 shows test sphere returns measured with the 915 MHz CW radar. Figure 5-55 shows the returns from the SCUBA equipped swimmer on the surface and Figure 5-56 shows the returns from the swimmer under water. The dark trace in the horizontal return was caused by external interference.

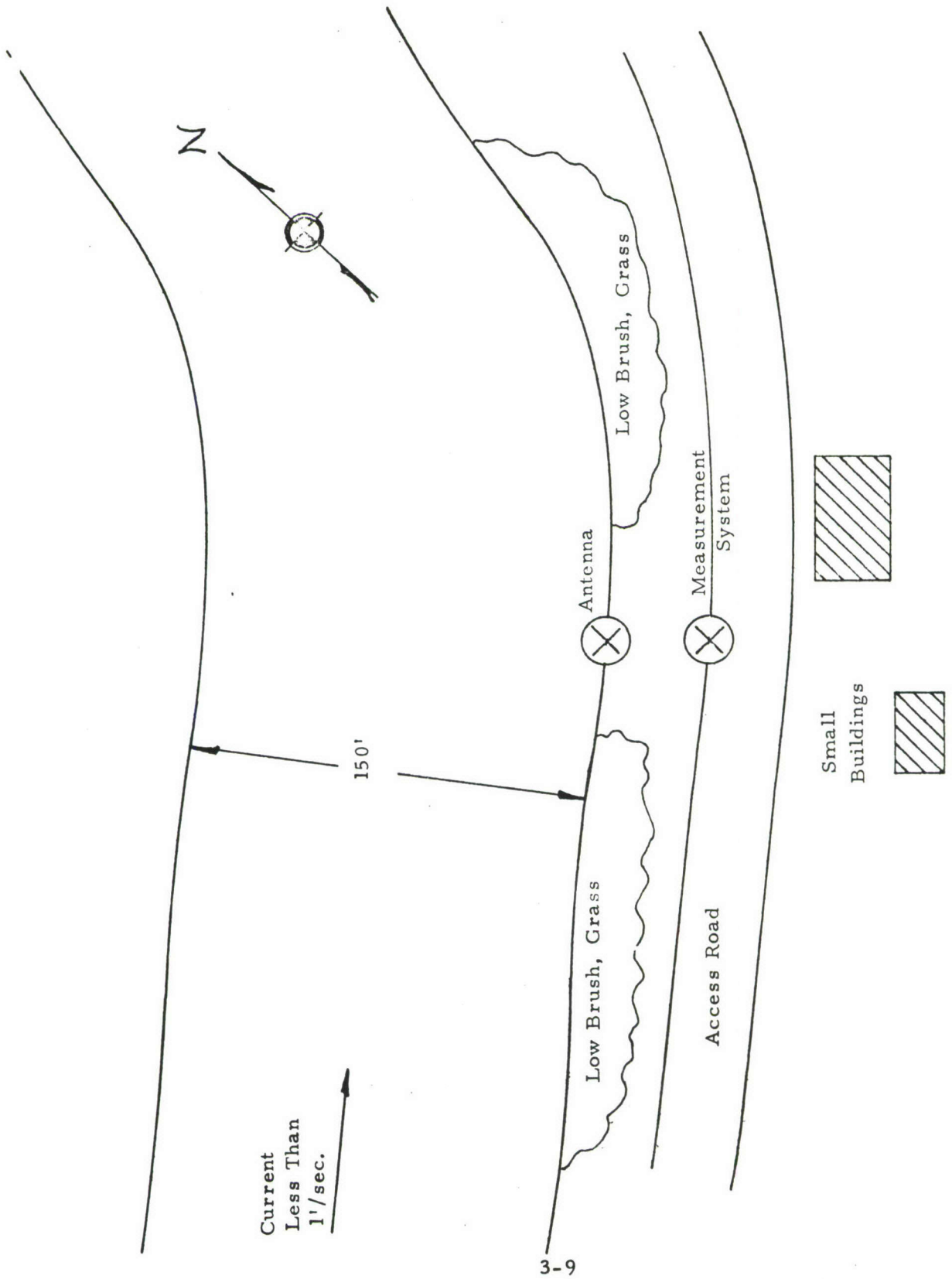


Figure 3-1 - Charles River Test Site  
Physical layout

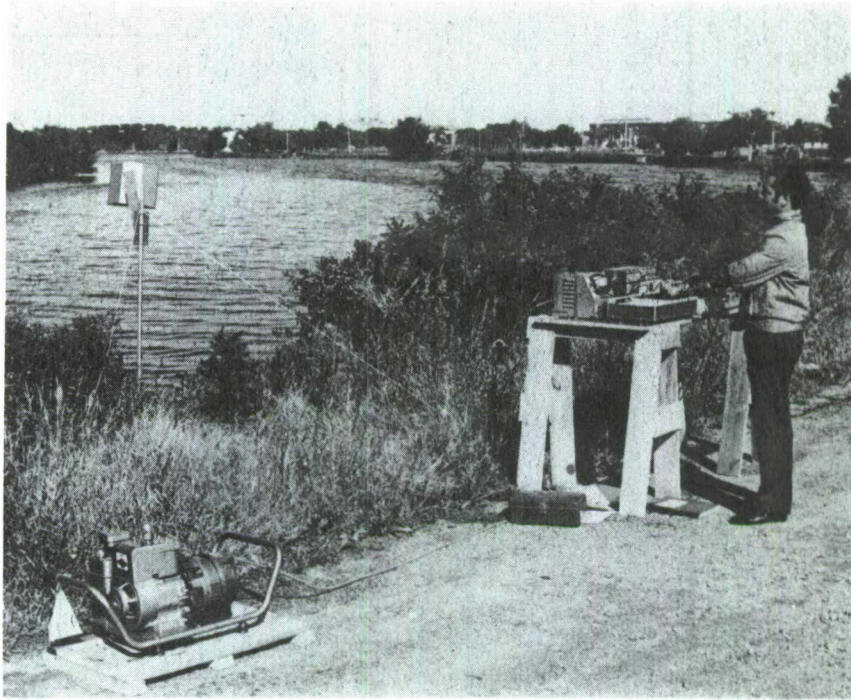


Figure 3-2 - Charles River Test Site

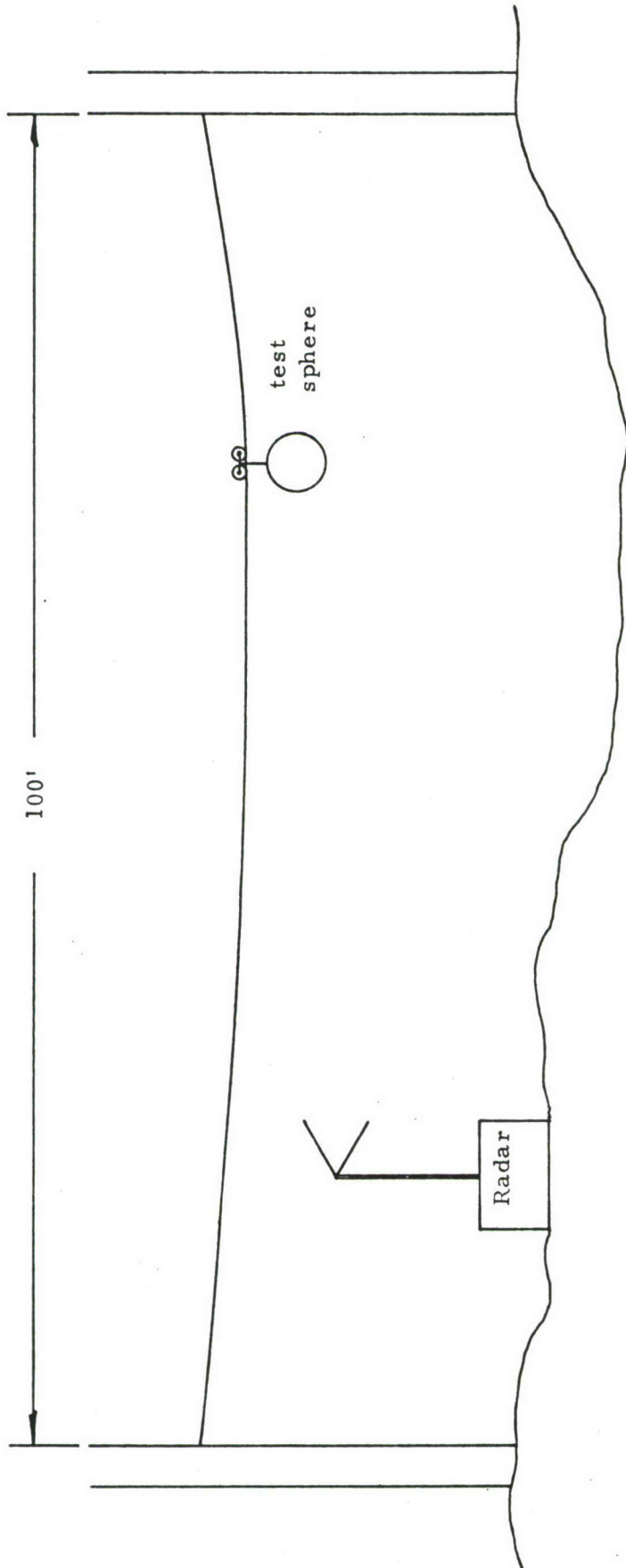


Figure 3-3 - Free Space Test Range  
Physical layout

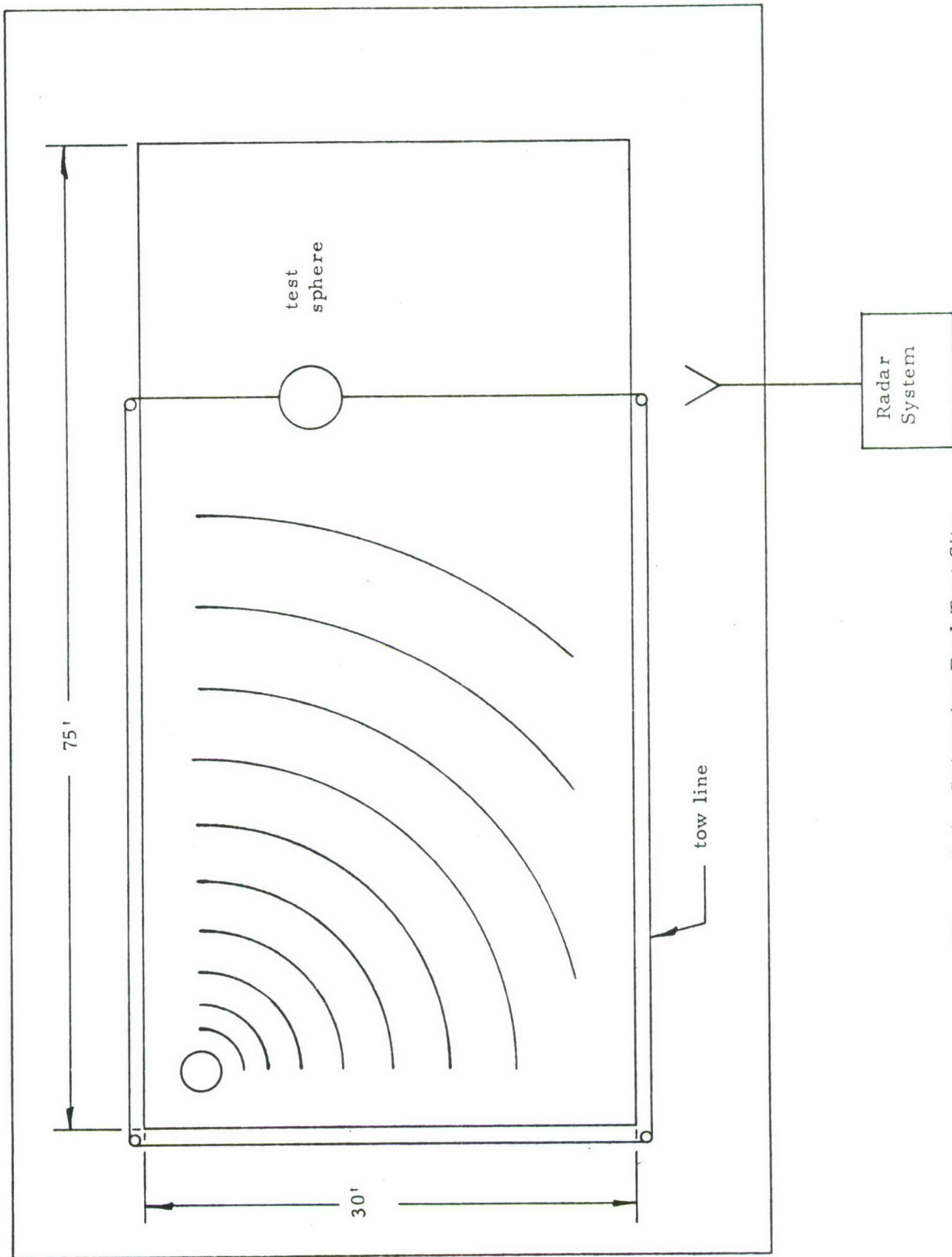


Figure 3-4 - Swimming Pool Test Site  
Physical layout

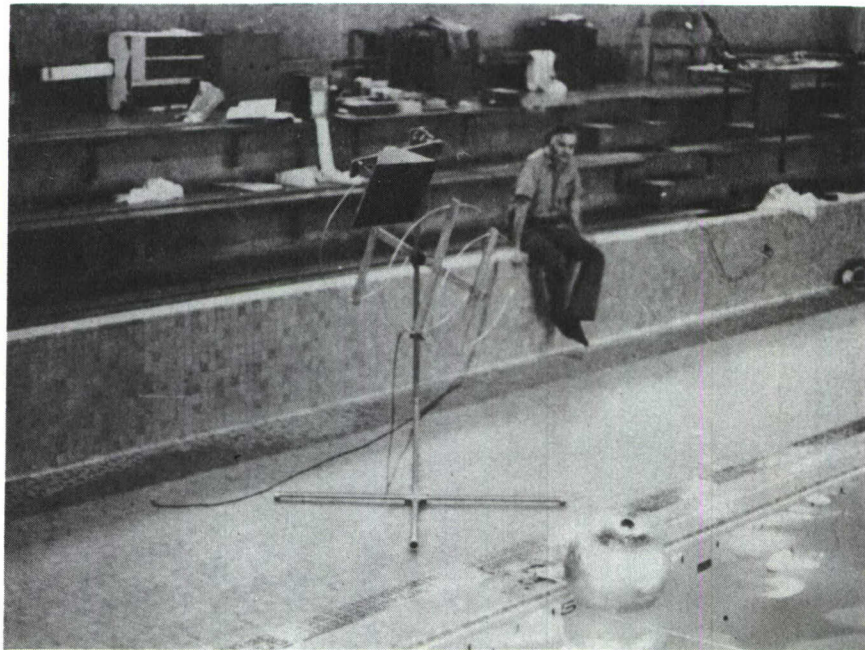


Figure 3-5 - Swimming Pool Test Site

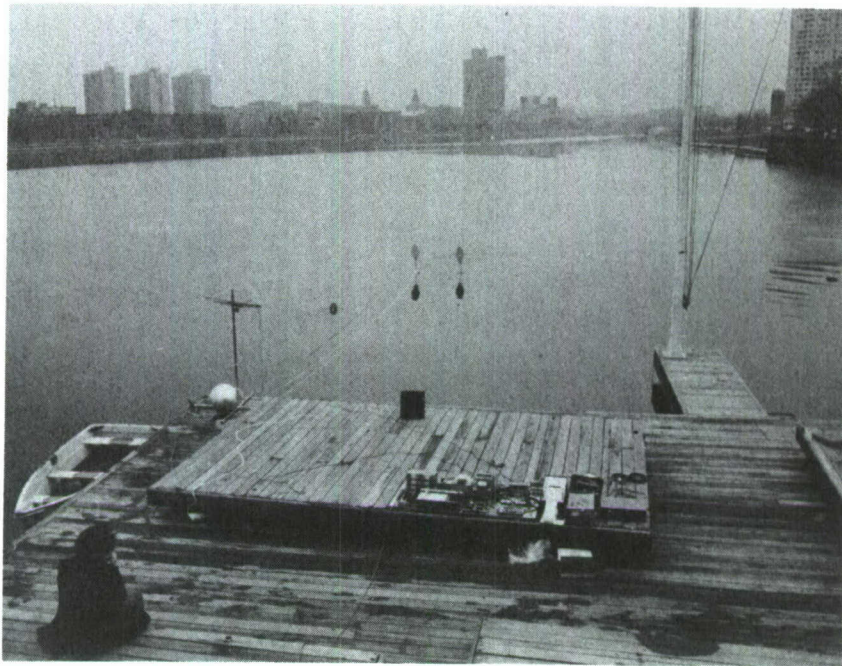
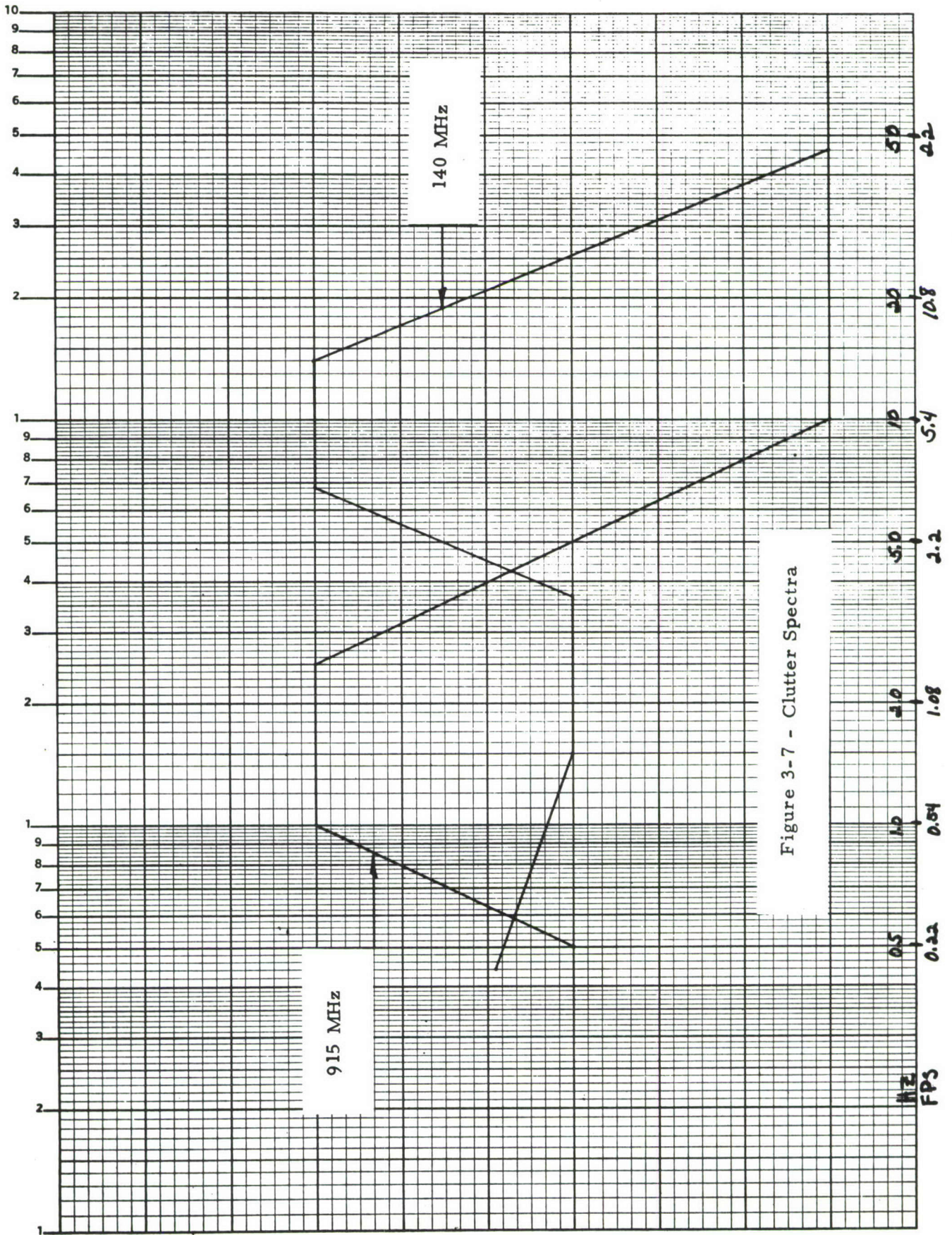


Figure 3-6 - MIT Test Site



## 4.0 CONCLUSIONS

### 4.1 CLUTTER SPECTRA

- a. For water surface waves with amplitudes up to 4 inches the clutter spectra exhibit a sharp peak within the doppler band of interest for swimmer detection at both 140 and 915 MHz. Most of the clutter energy lies in a very narrow band around the spectrum peak.
- b. The peak frequency varies only slightly (less than 2 octaves) for a wide range of wave conditions.
- c. The peak amplitude is a direct function of surface activity.
- d. The vertically polarized return is stronger (by up to 20 dB) than the horizontal return for low angle grazing beams.
- e. The velocity of windblown waves on the water surface appears to the radar as an unbalanced doppler return and may be detected as a target, whereas the return from a random wave pattern, ie. waves with no net surface velocity, is suppressed somewhat by balanced processing.
- f. The general character of the clutter spectra is the same as measured by both CW and pulsed systems.

### 4.2 TARGET RETURNS

- a. The 140 MHz and 915 MHz CW radars were capable of detections of a swimmer on the water surface to a range of 30 feet under calm conditions, using either vertical or horizontal polarization.
- b. The 915 MHz CW radar detected a SCUBA equipped swimmer 2 feet below the surface at ranges up to 15 feet under calm conditions using vertical polarization, although the detections may be based on a surface effect caused by the water displacement of the subsurface swimmer.
- c. Reliable swimmer detections were not possible with either CW radar when the water surface was disturbed substantially.
- d. The 915 MHz pulsed radar produced a much improved target to clutter ratio over either CW radar.
- e. The 915 MHz pulsed radar was able to detect a surface swimmer in calm or moderately disturbed water at a range of thirty feet. This range was limited by the fixed range gate position of the

radar. Detection should be possible at considerably greater ranges since the target to clutter ratio for the pulsed system decreases relatively slowly with range. (Ratio  $\propto \frac{1}{R}$ )

- f. An underwater SCUBA equipped swimmer was also detected in calm water at a 30 foot range by the pulsed radar using vertical polarization. The amplitude of the return appeared to be strongly dependent on the attitude of the swimmer's air tank.
- g. Vertical polarization produced the strongest target returns and some apparent surface penetration.
- h. Based on comparison with test target of known cross section, a swimmer with head only above water has a cross section of about  $0.1 \text{ ft.}^2$  at 140 MHz.
- i. Based on comparison with a target of known cross section, a swimmer with head only above water has a radar cross section of about  $0.8 \text{ ft.}^2$  at 915 MHz.
- j. The clutter cell area at 20 feet for the pulsed radar was :  
 $A = R \Delta \theta \Delta R = 20 \times 1 \times 1 = 100 \text{ ft.}^2$
- k. The normalized clutter cross section (cross section/unit clutter area) for moderately disturbed surface (4" random waves) is  $\approx 0.8 \times 10^{-2} = -22 \text{ dB}$

#### 4.3 OBSERVATIONS

Based on the total data gathered, the following can be concluded:

- a. It appears that a system for the automatic detection of surface swimmers can be built.
- b. The same system would have a moderate amount of subsurface SCUBA equipped swimmer detection capability, particularly under relatively calm surface conditions and at ranges under 30 feet.
- c. The system which should be able to perform the swimmer detection best would operate at high UHF or low L-band, utilize vertical polarization and operate with a high range-resolution signal subsystem.
- d. The signal processor would utilize balanced processing to suppress the random components of background fluctuations plus a form of automatic adaptive notch filter to suppress the

peak unbalanced clutter component. Alternatively, the normal zero-doppler notch of the balanced processor might automatically be positioned at the measured peak clutter frequency to avoid the need for a separate notch filter. The relative desirability of each of these approaches would have to be studied.

## 5.0 SELECTED CHART RECORDINGS

Measurements were taken using both CW and pulsed radars. Spectral density plots were made with a Hewlett-Packard X-Y plotter while a Brush strip chart recorder was used to obtain data on signal return amplitude vs. time recordings. Certain chart recordings were selected as representative and are presented in this section. A brief discussion of the conditions during the experiments may be found in Section 3.

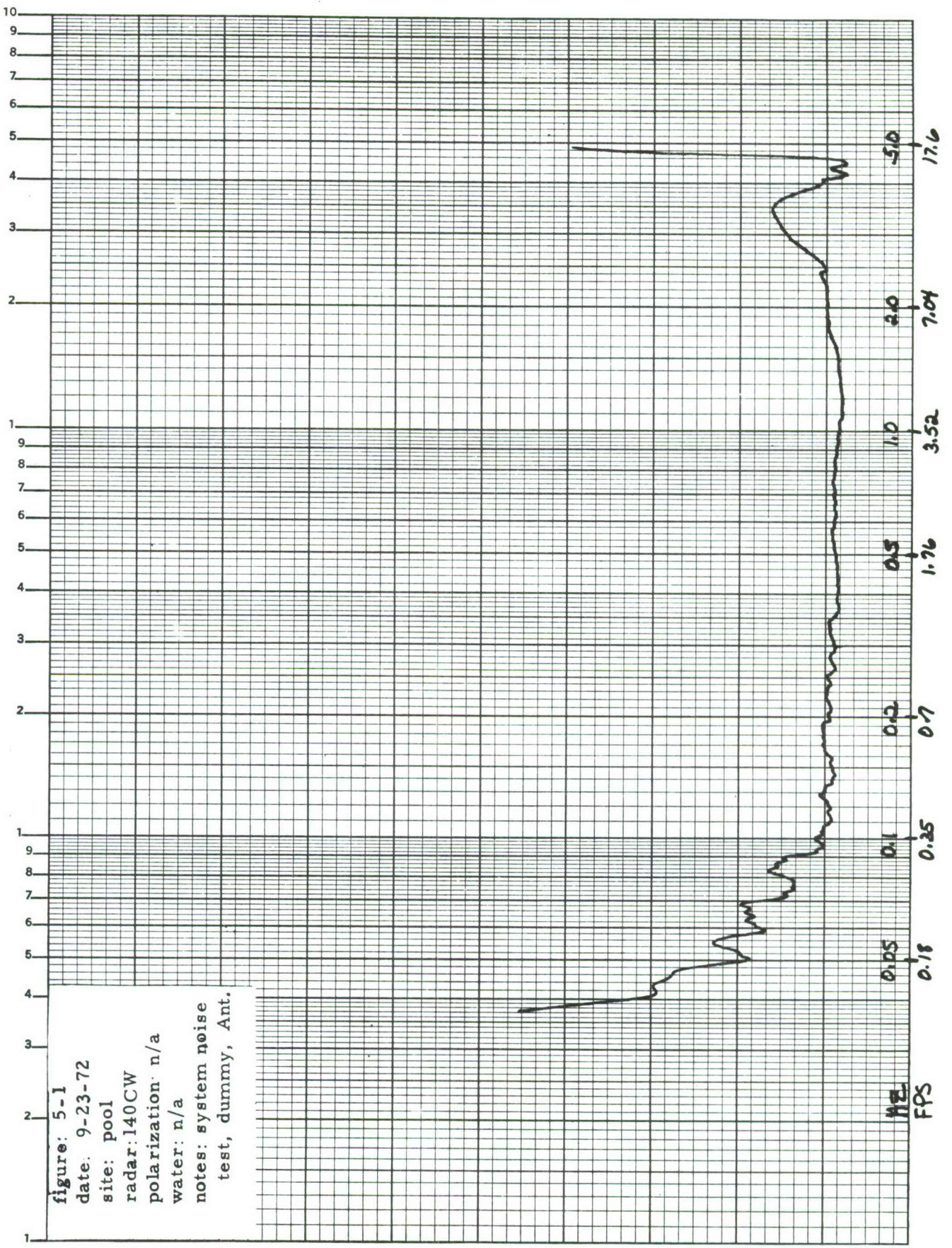
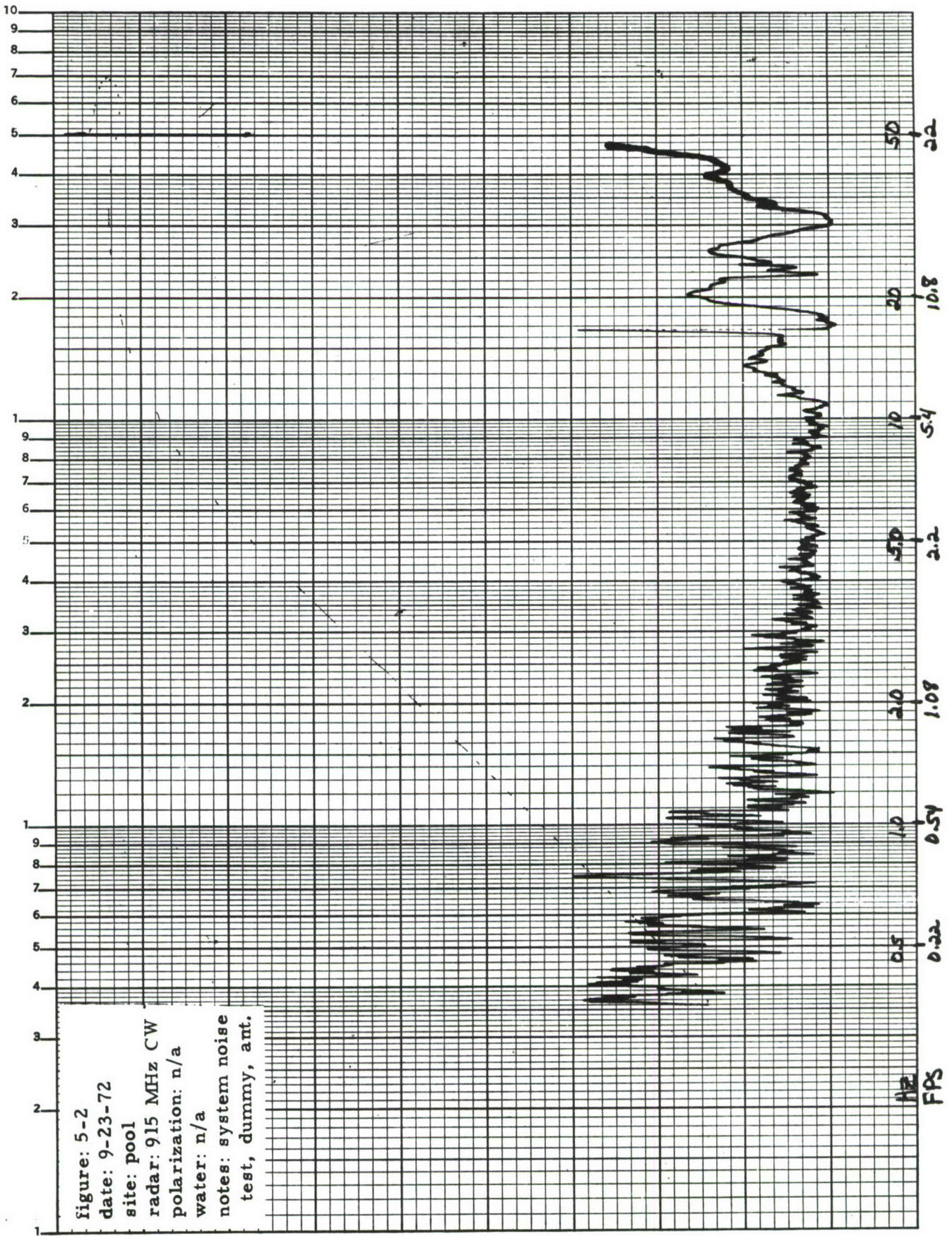
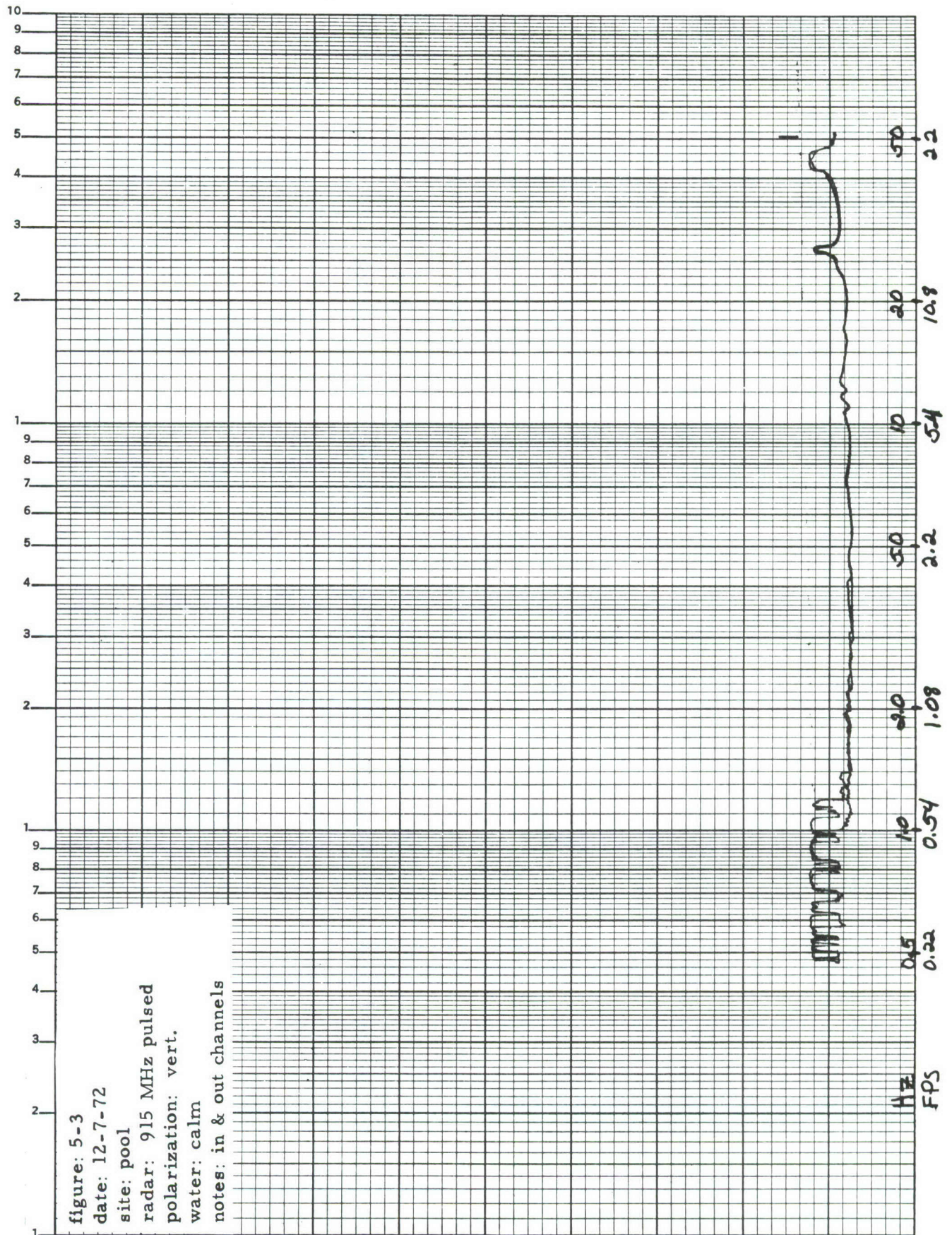
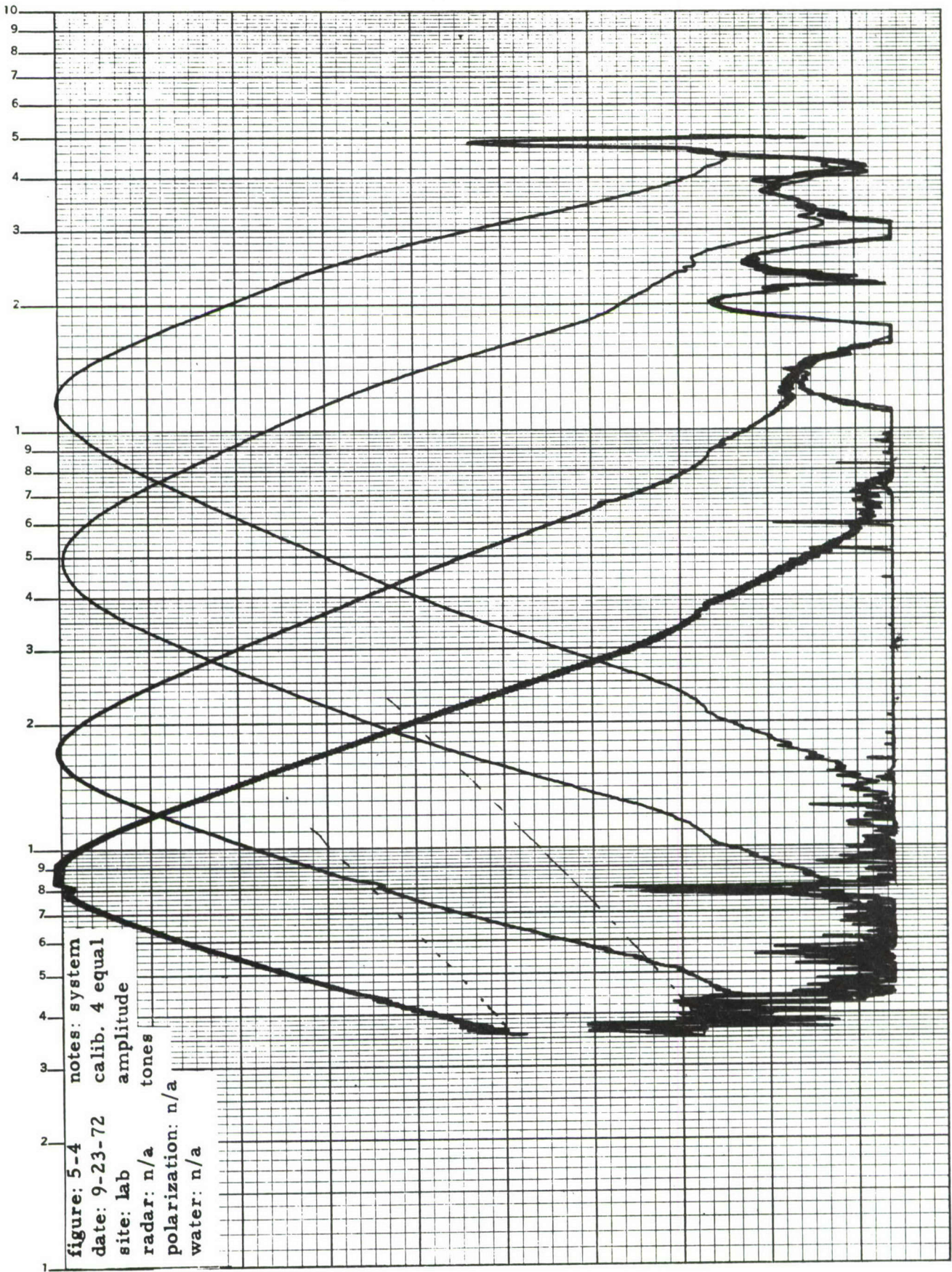


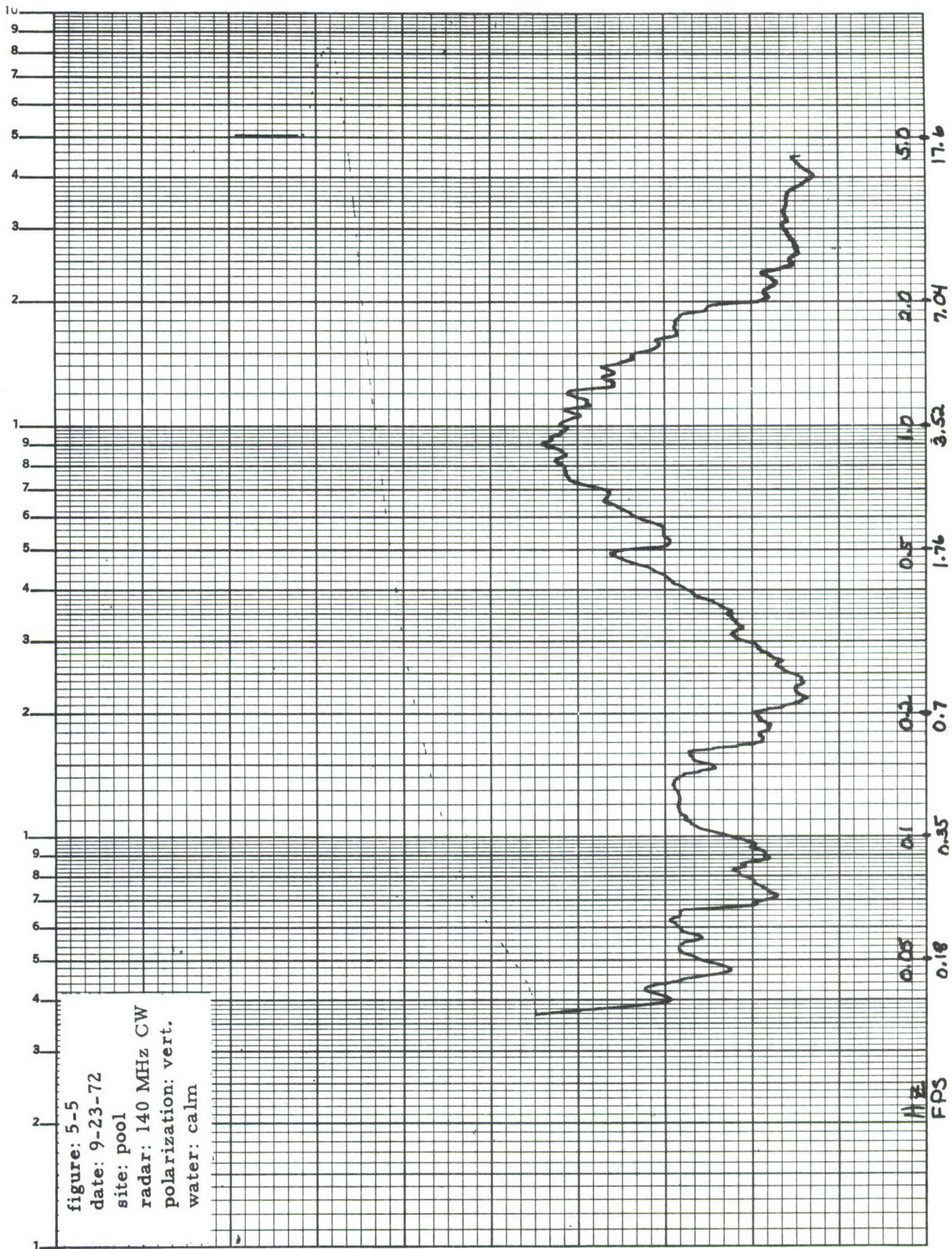
figure: 5-1  
 date: 9-23-72  
 site: pool  
 radar: 140CW  
 polarization: n/a  
 water: n/a  
 notes: system noise  
 test, dummy, Ant.

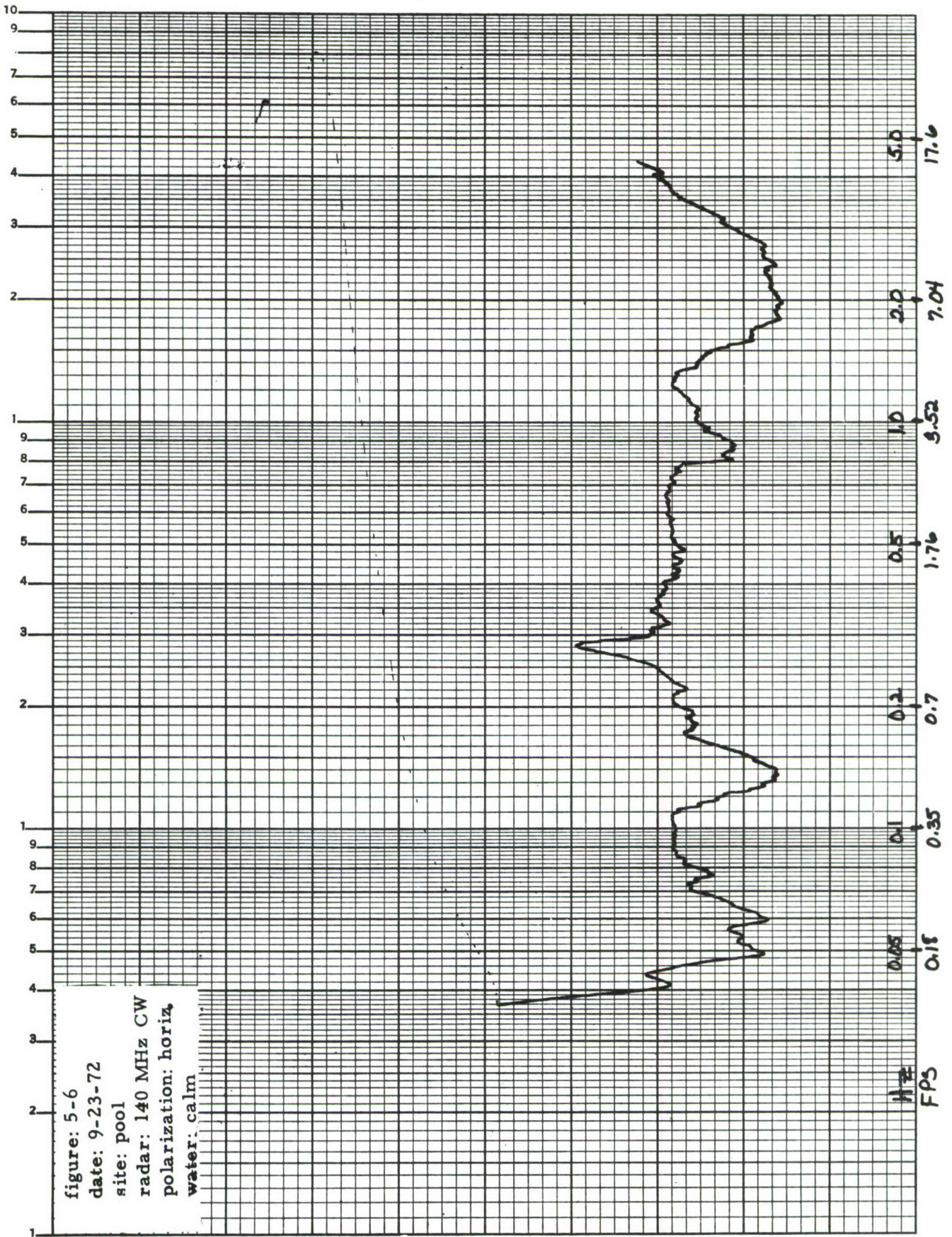


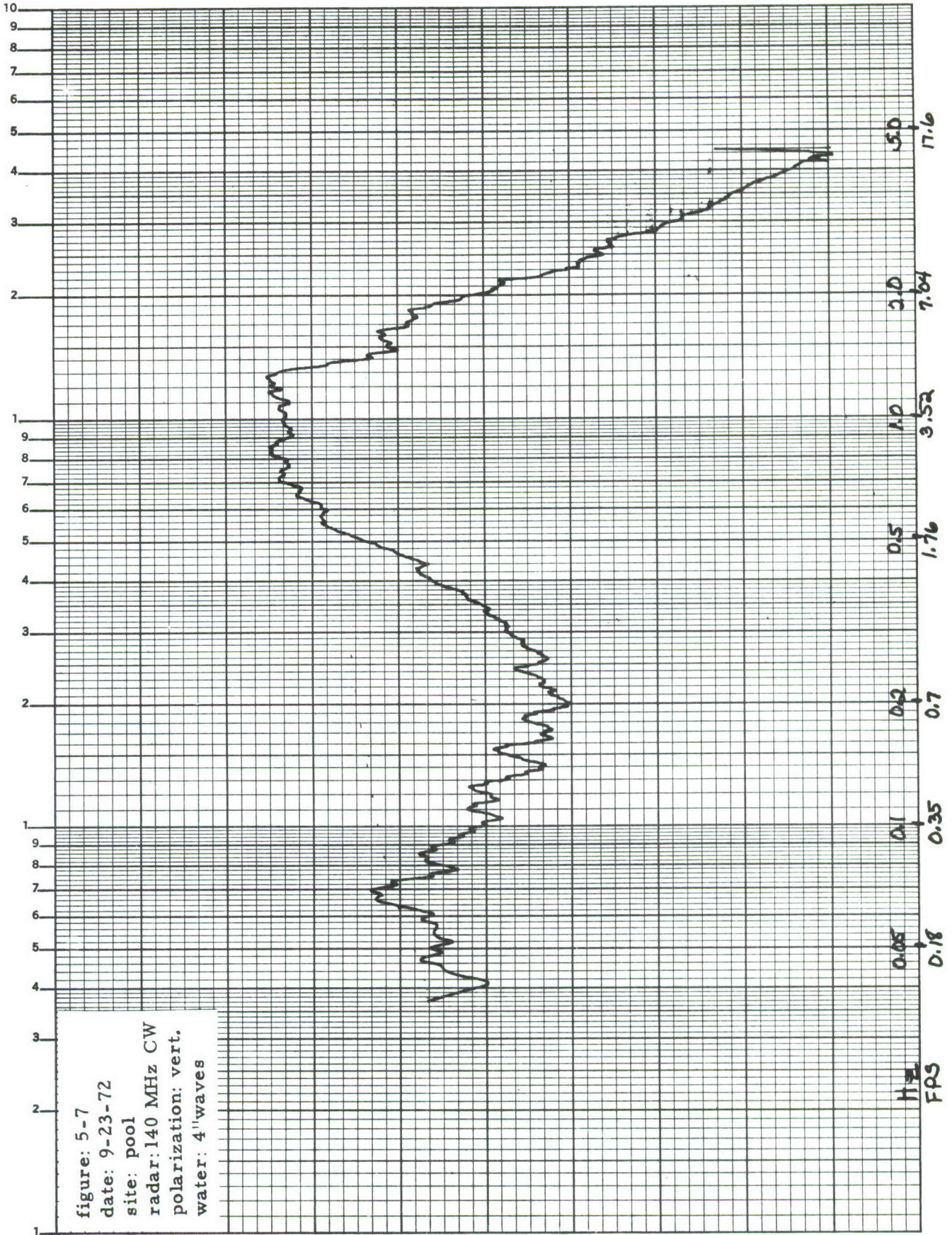


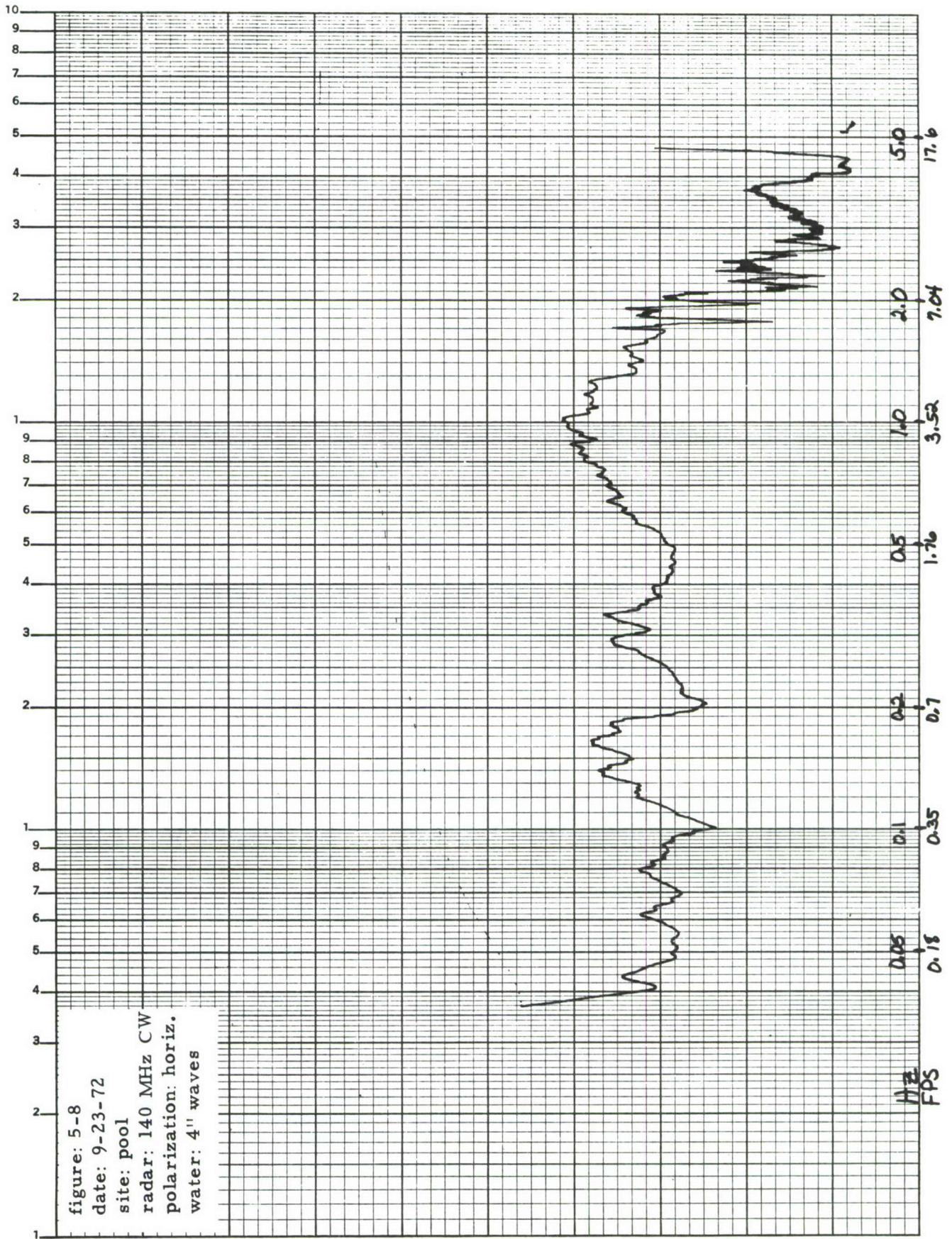


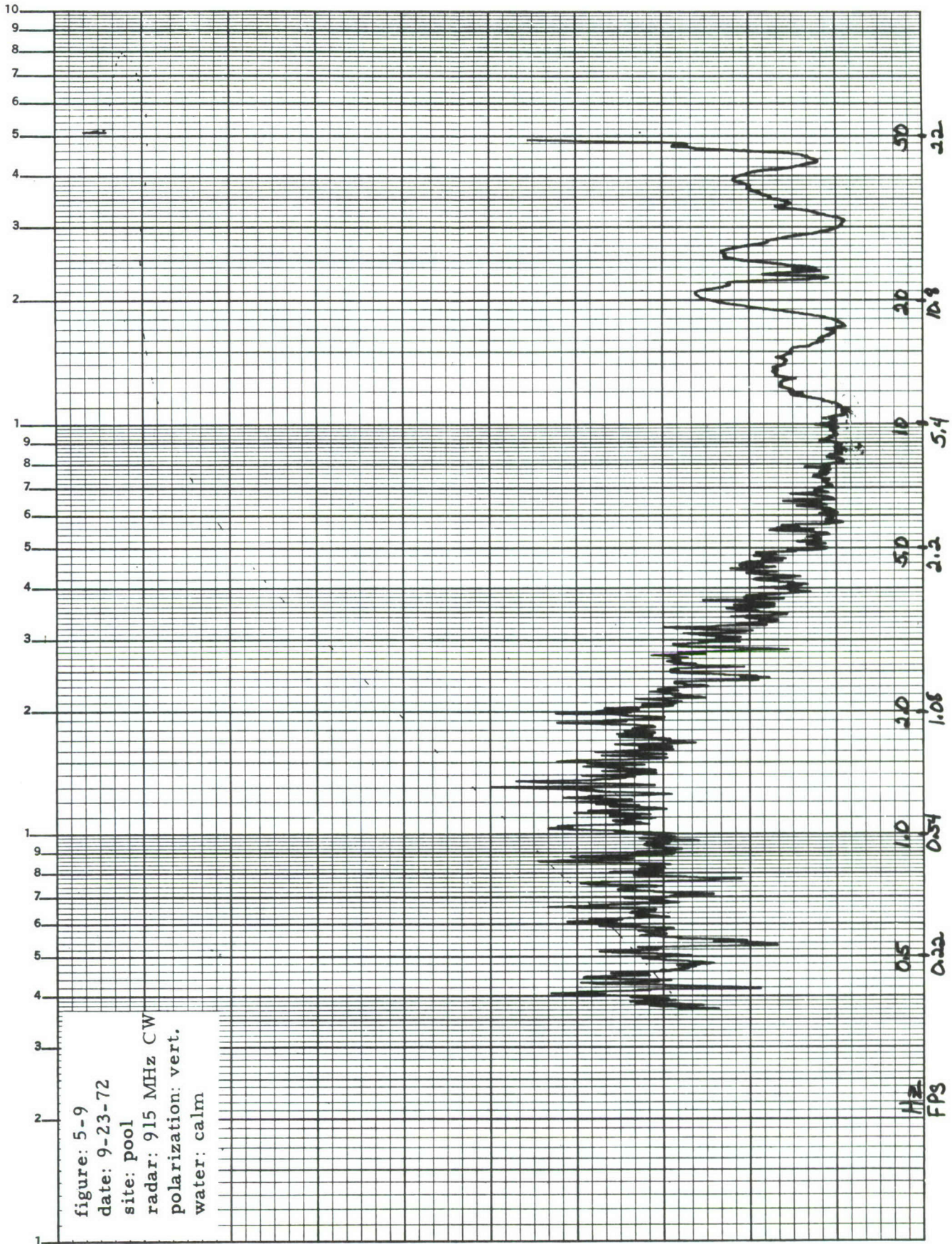
**figure: 5-4** notes: system  
**date: 9-23-72** calib. 4 equal  
**site: lab** amplitude  
**radar: n/a** tones  
**polarization: n/a**  
**water: n/a**



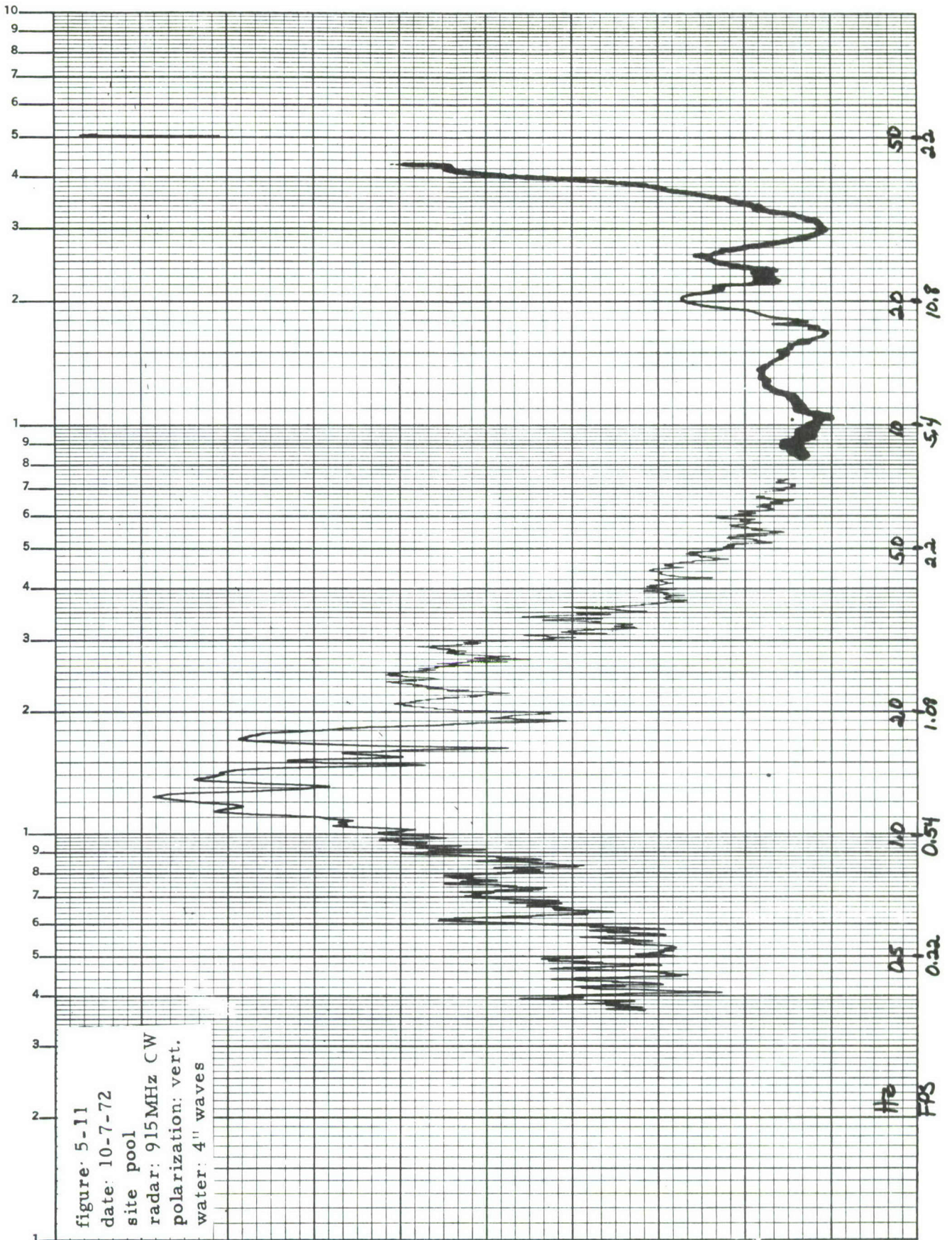




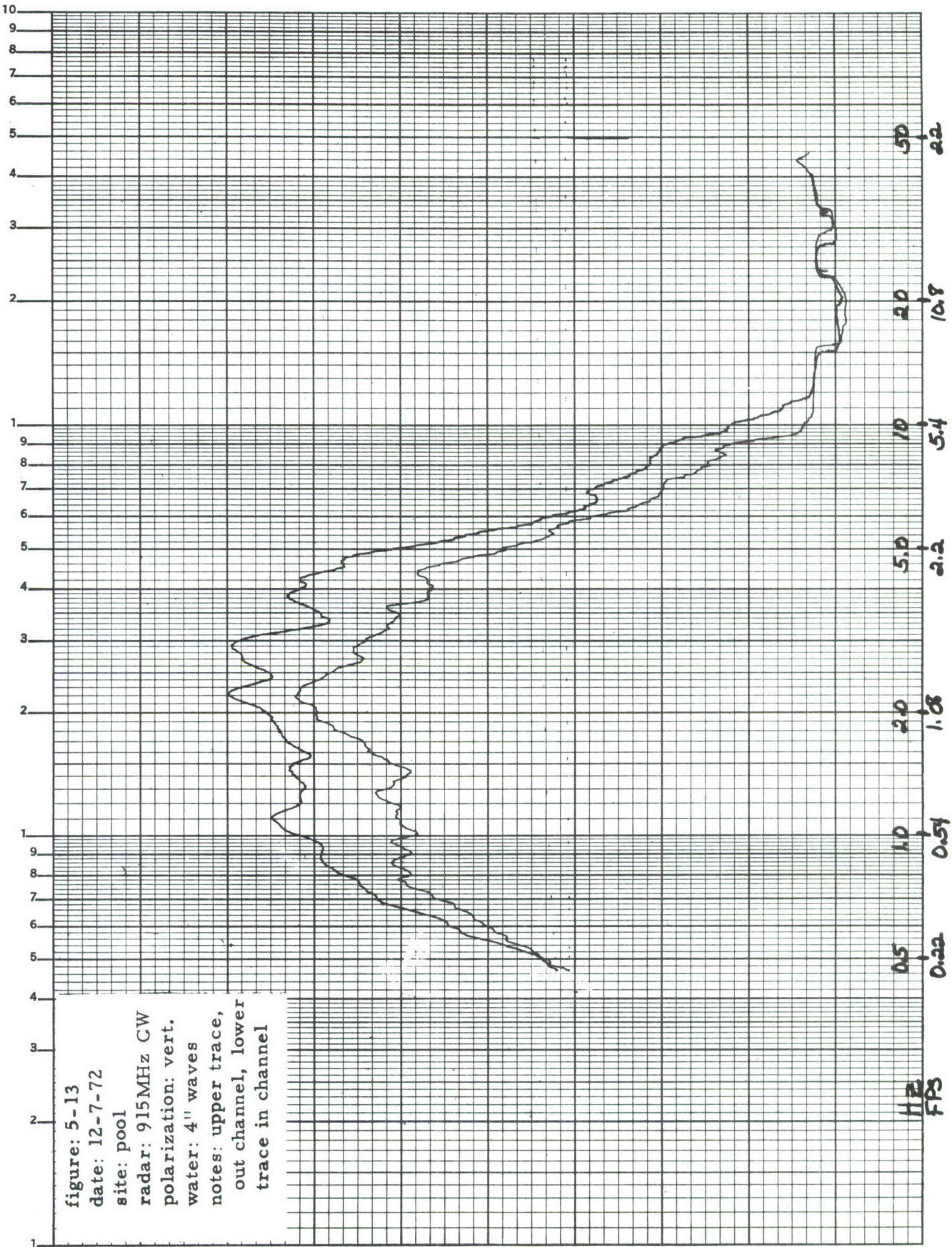












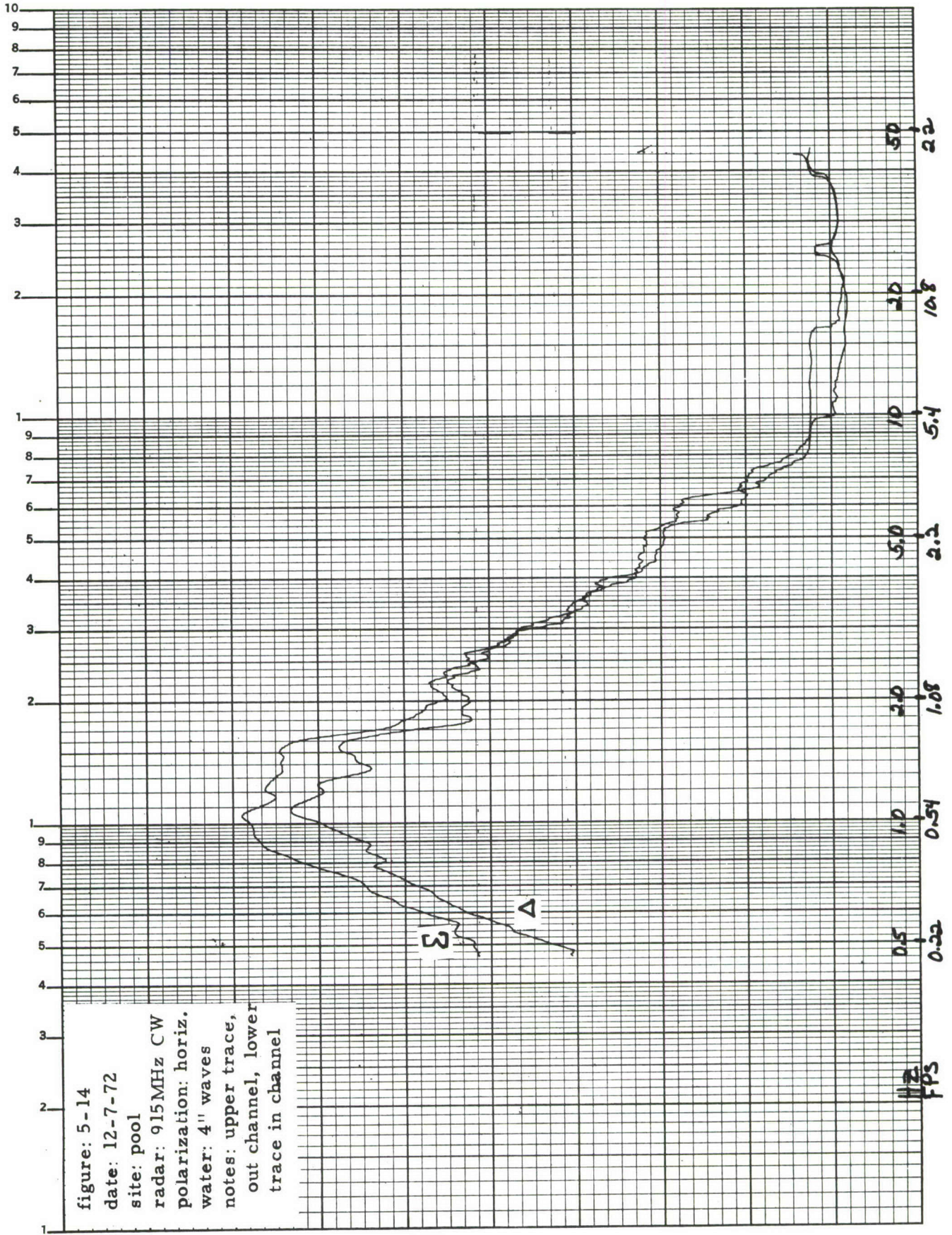


figure: 5-14  
 date: 12-7-72  
 site: pool  
 radar: 915MHz CW  
 polarization: horiz.  
 water: 4" waves  
 notes: upper trace, out channel, lower trace in channel

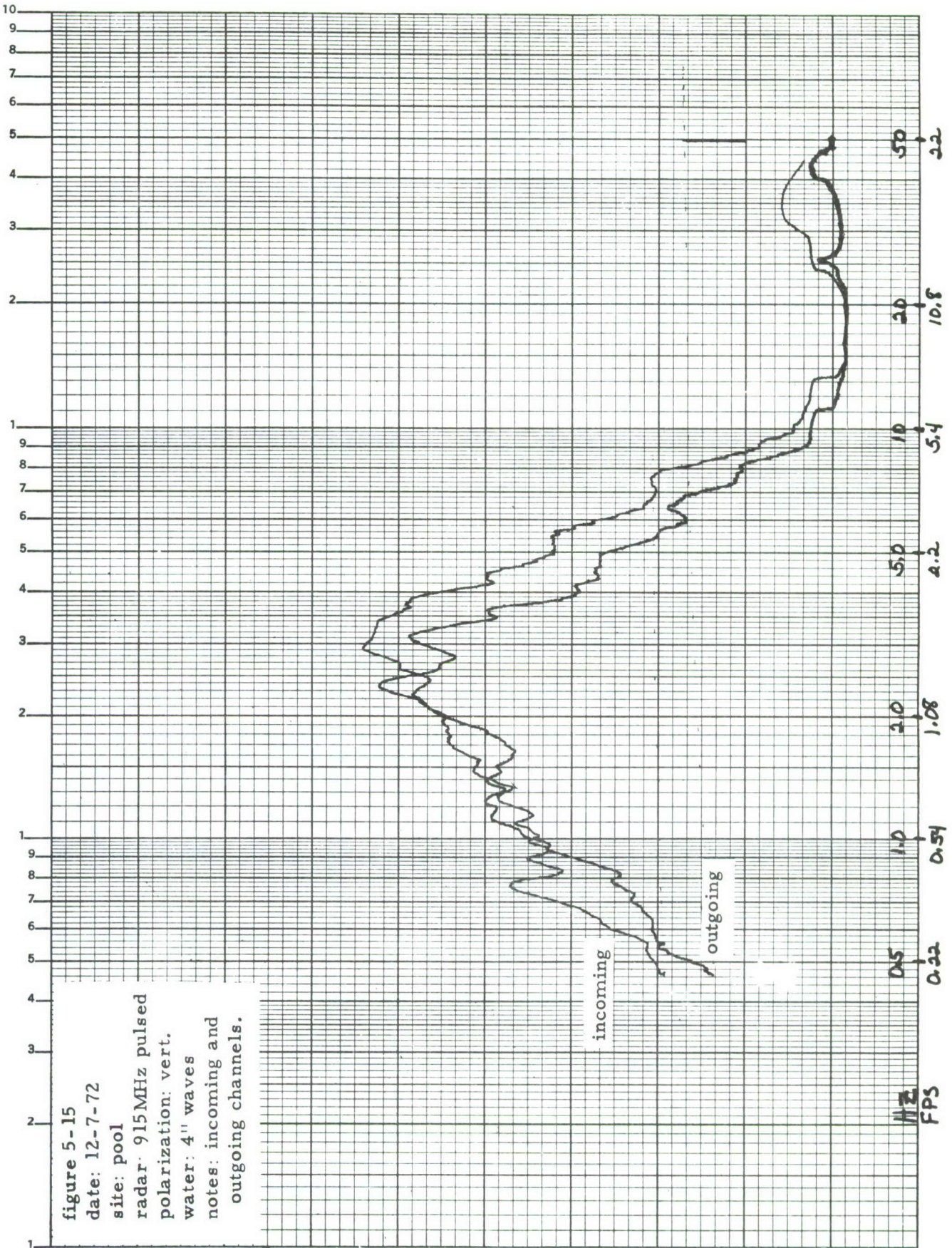
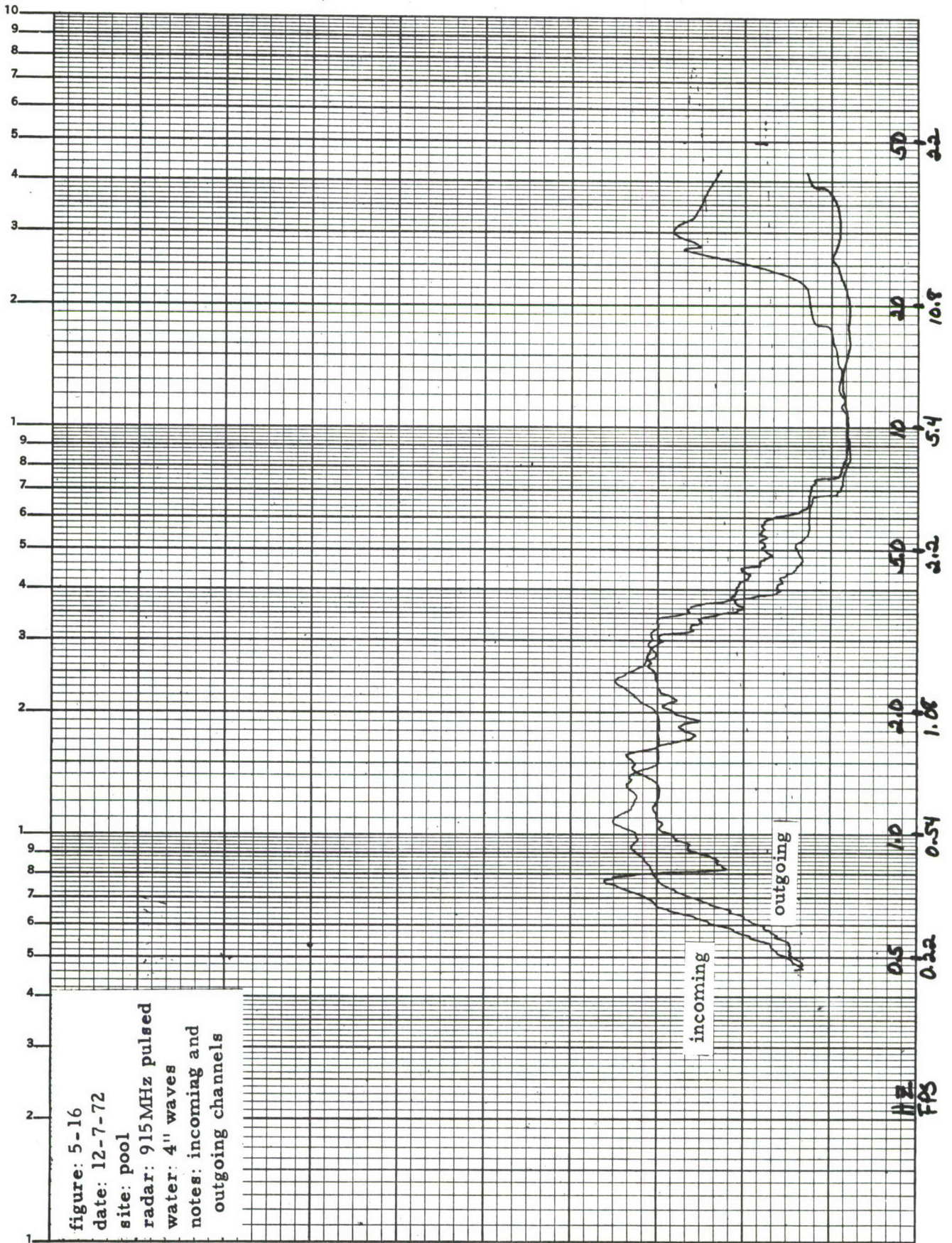
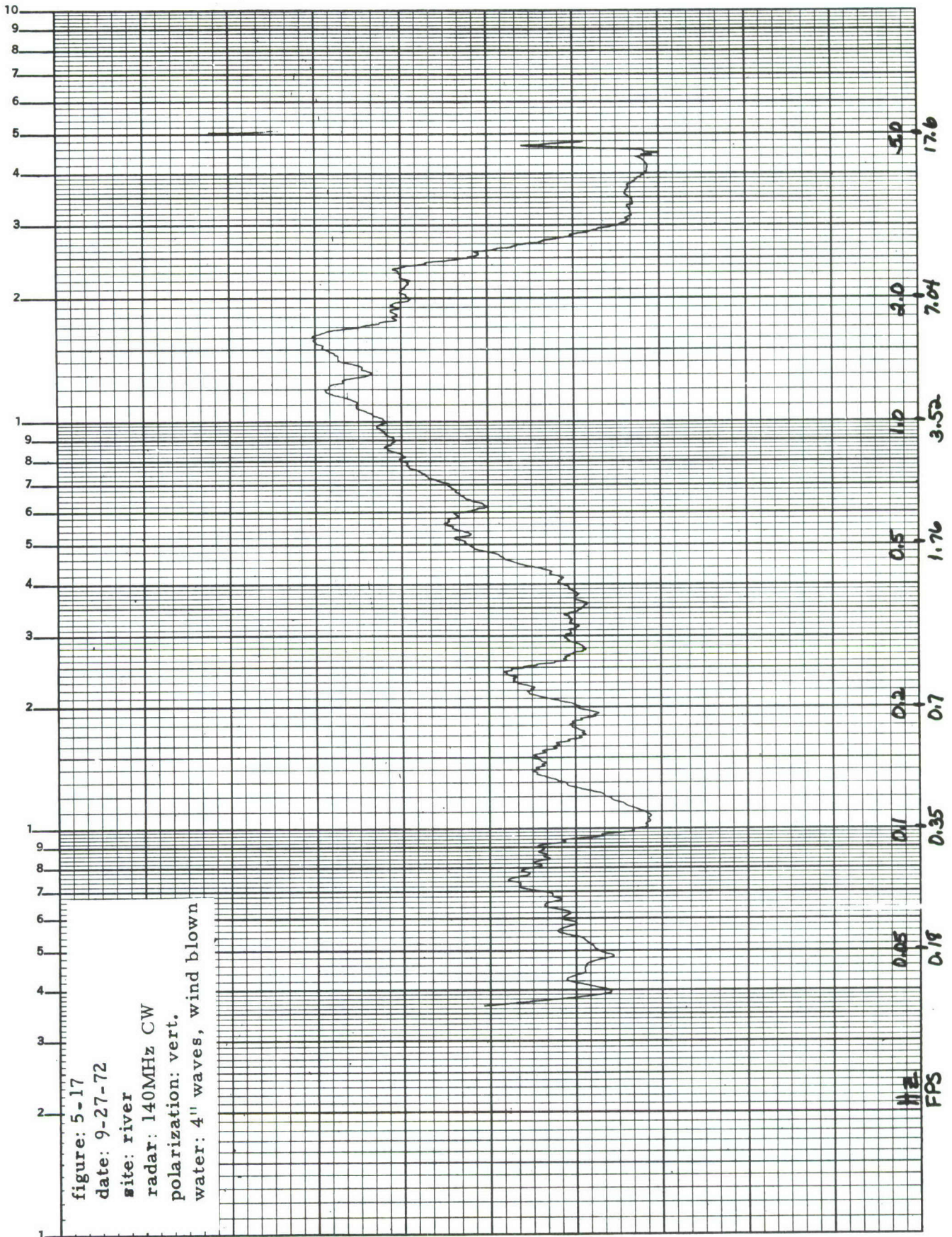
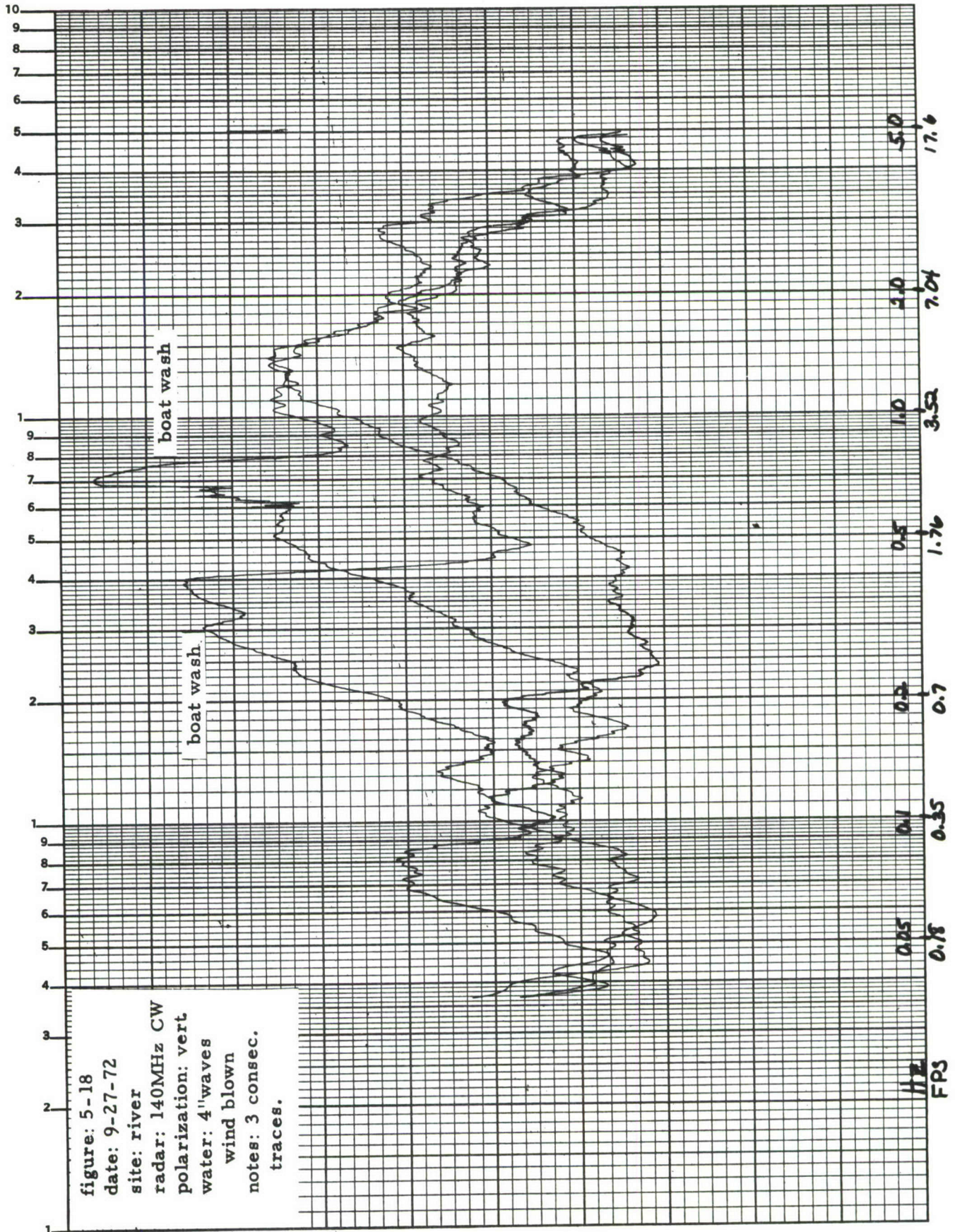
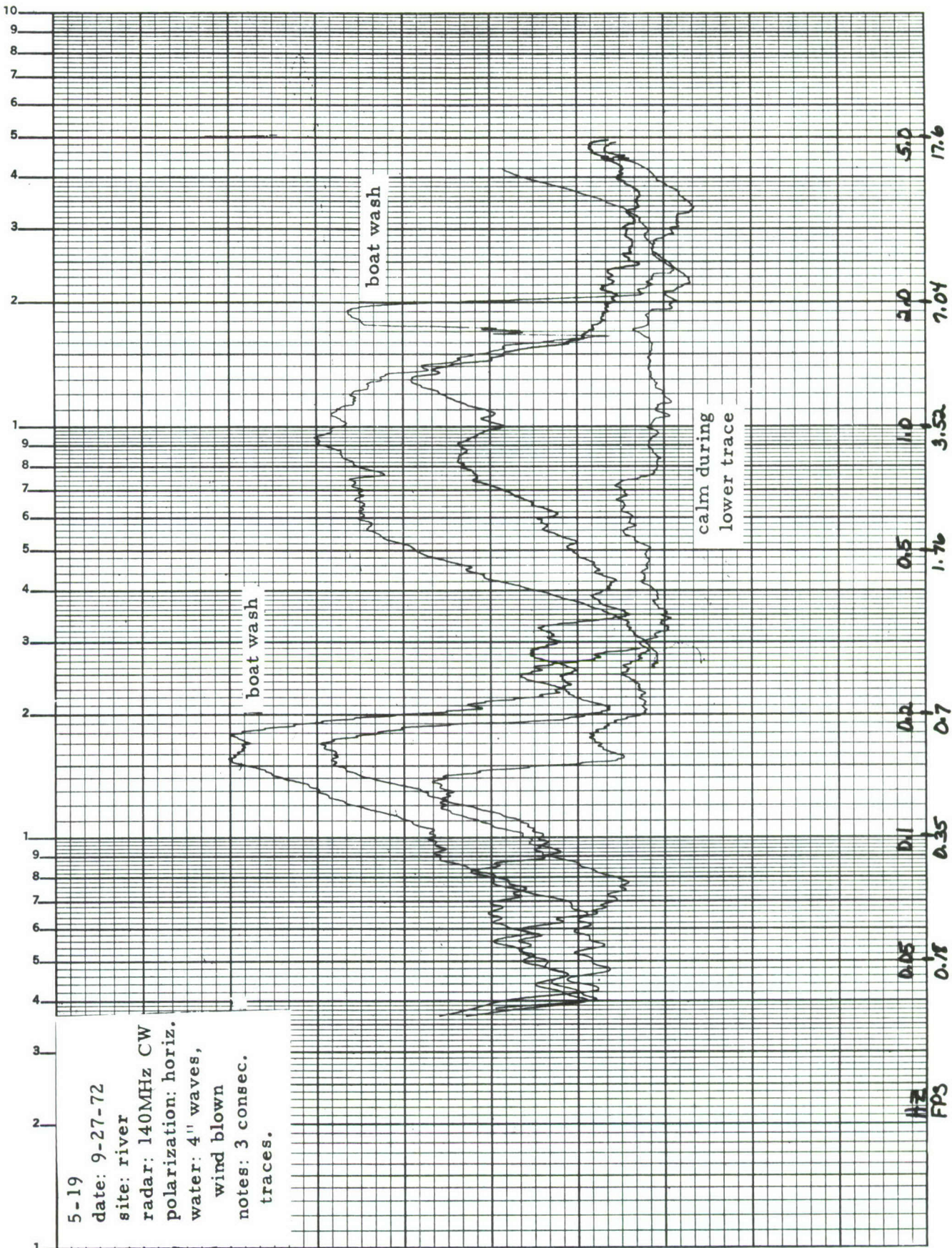


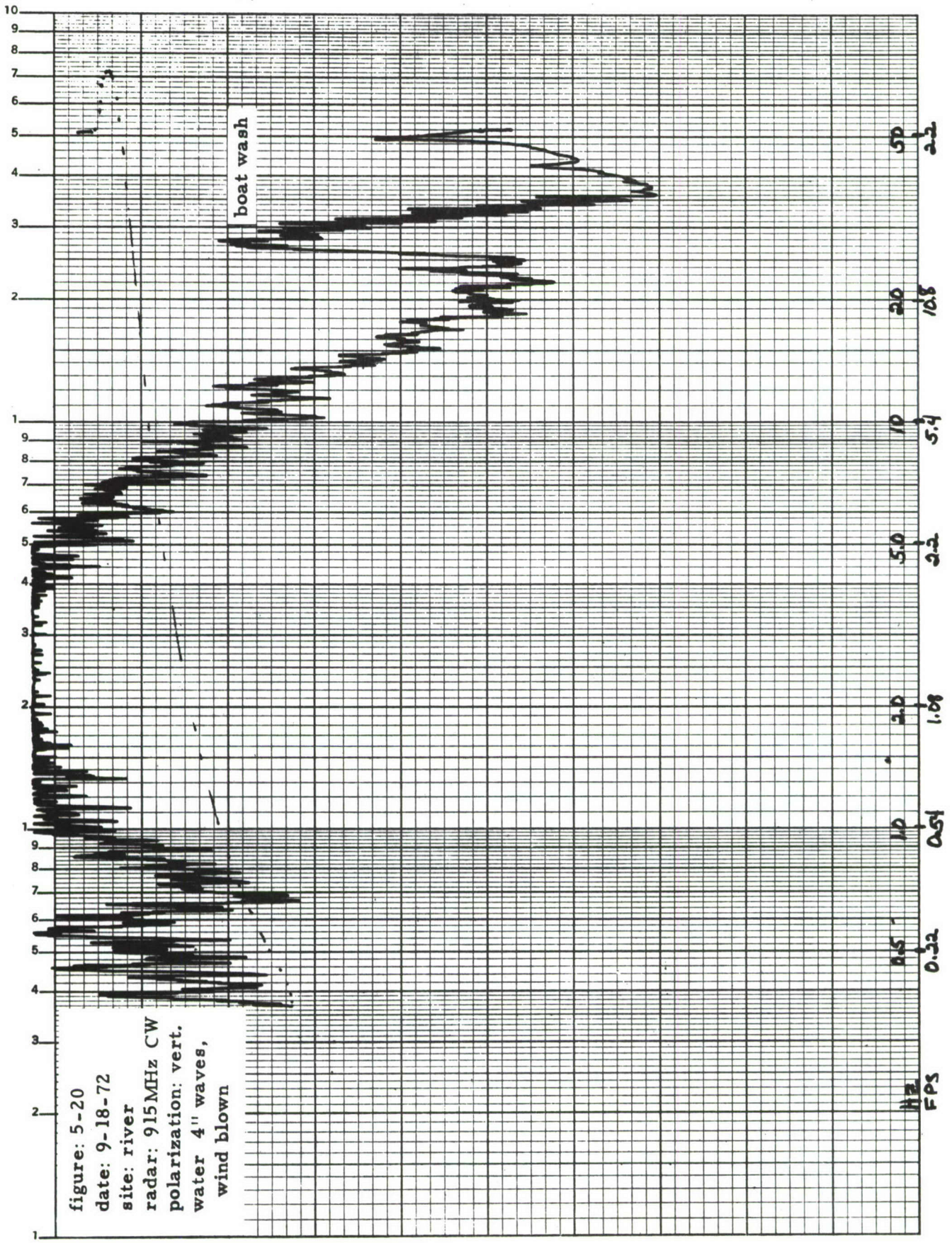
figure 5-15  
 date: 12-7-72  
 site: pool  
 radar: 915MHz pulsed  
 polarization: vert.  
 water: 4" waves  
 notes: incoming and  
 outgoing channels.

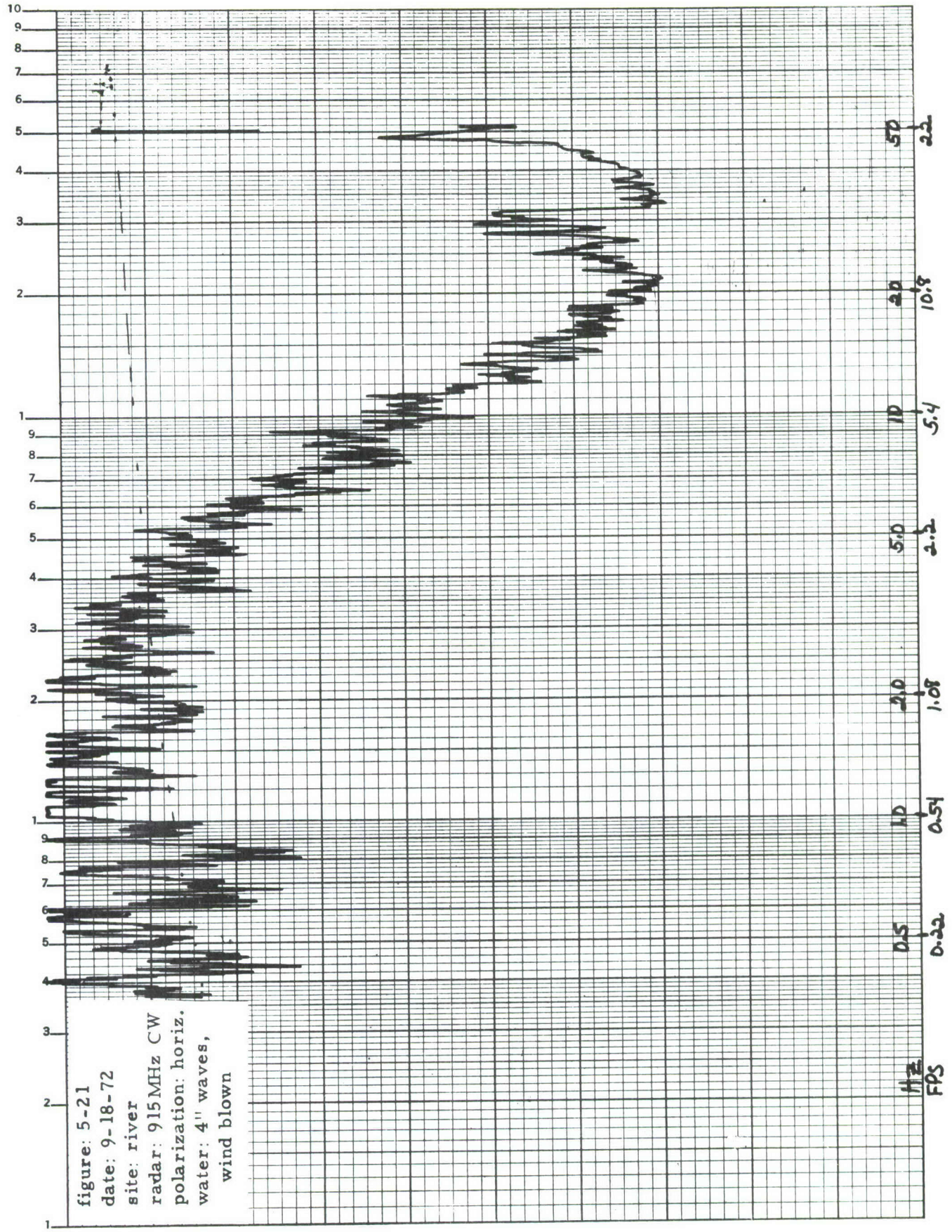








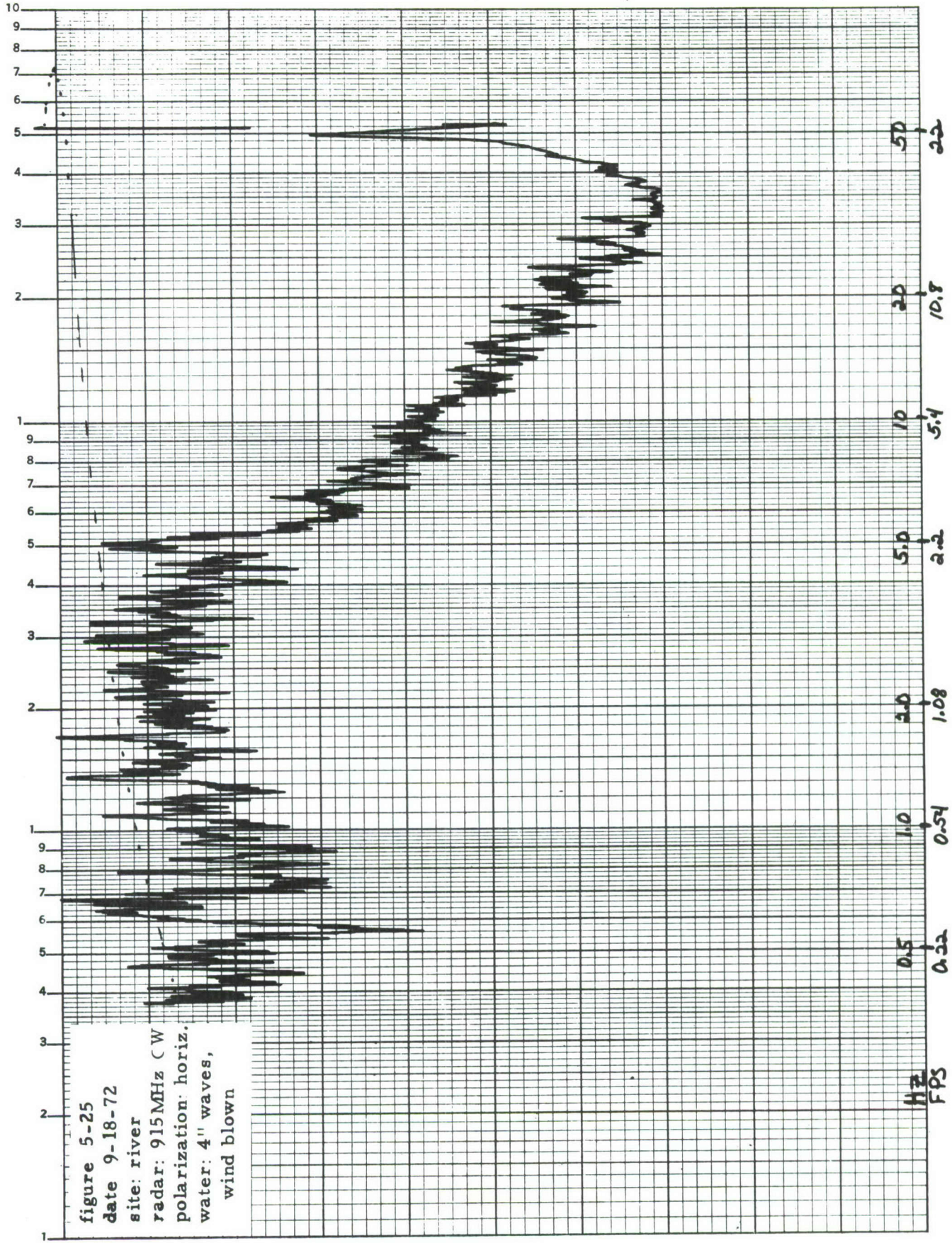


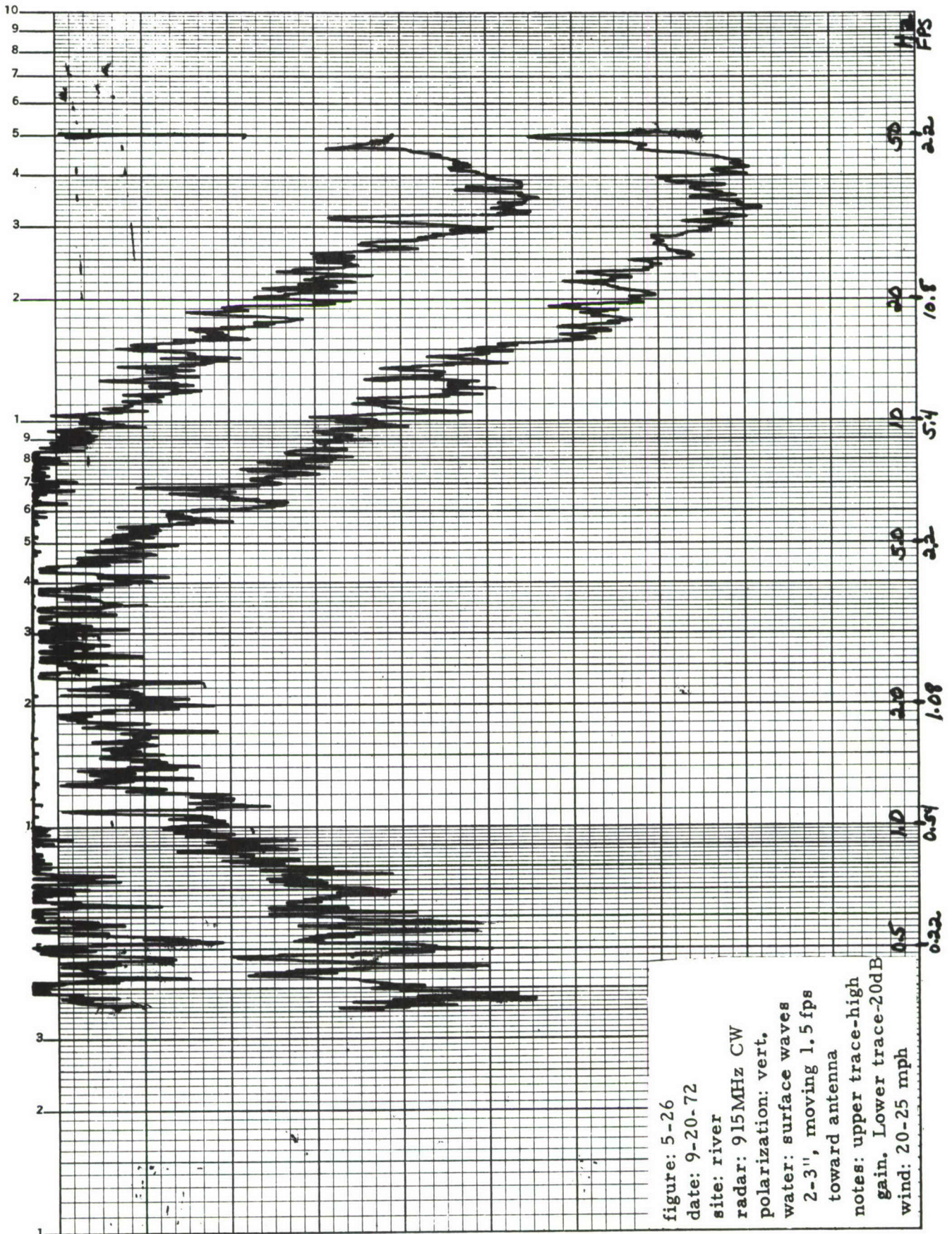












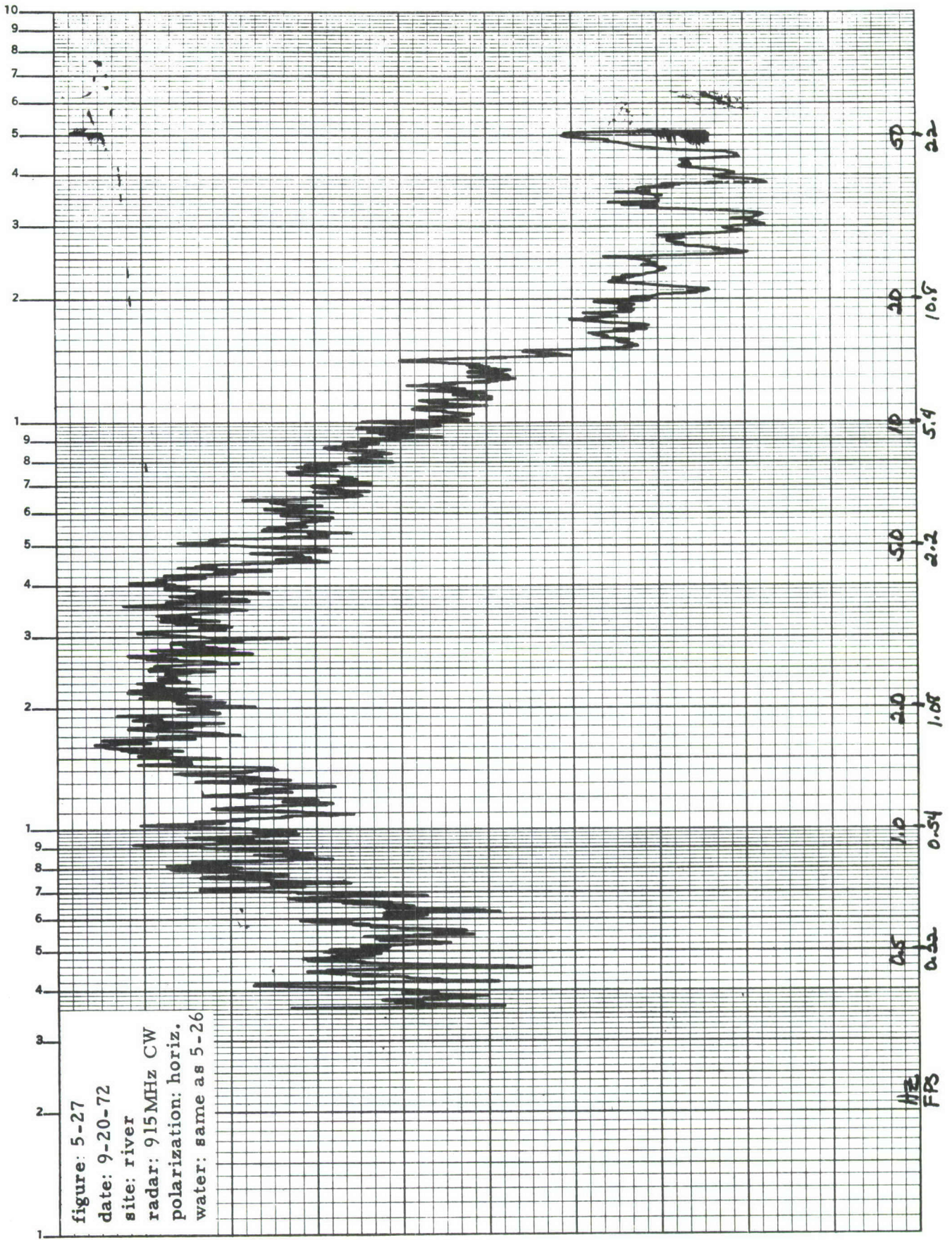
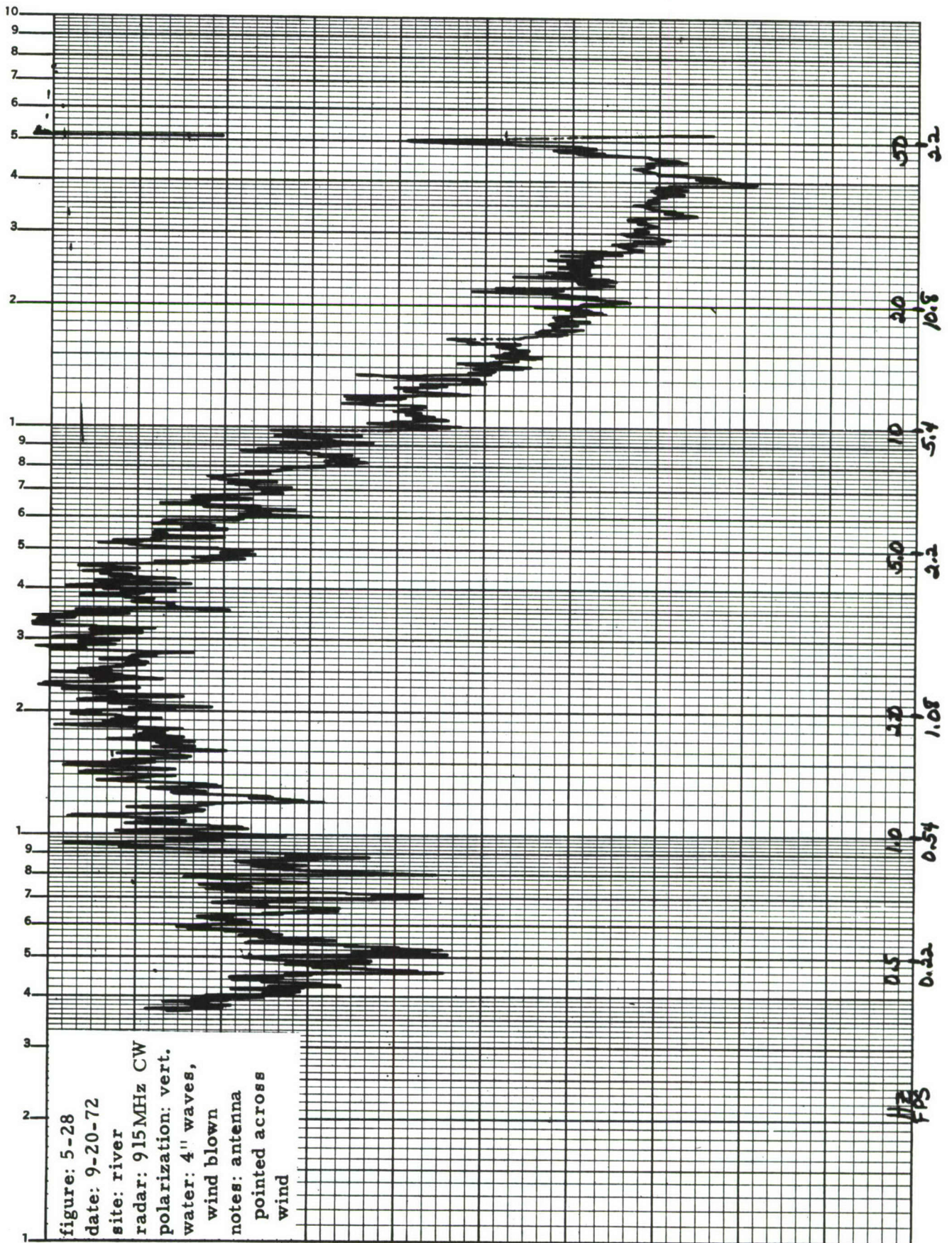
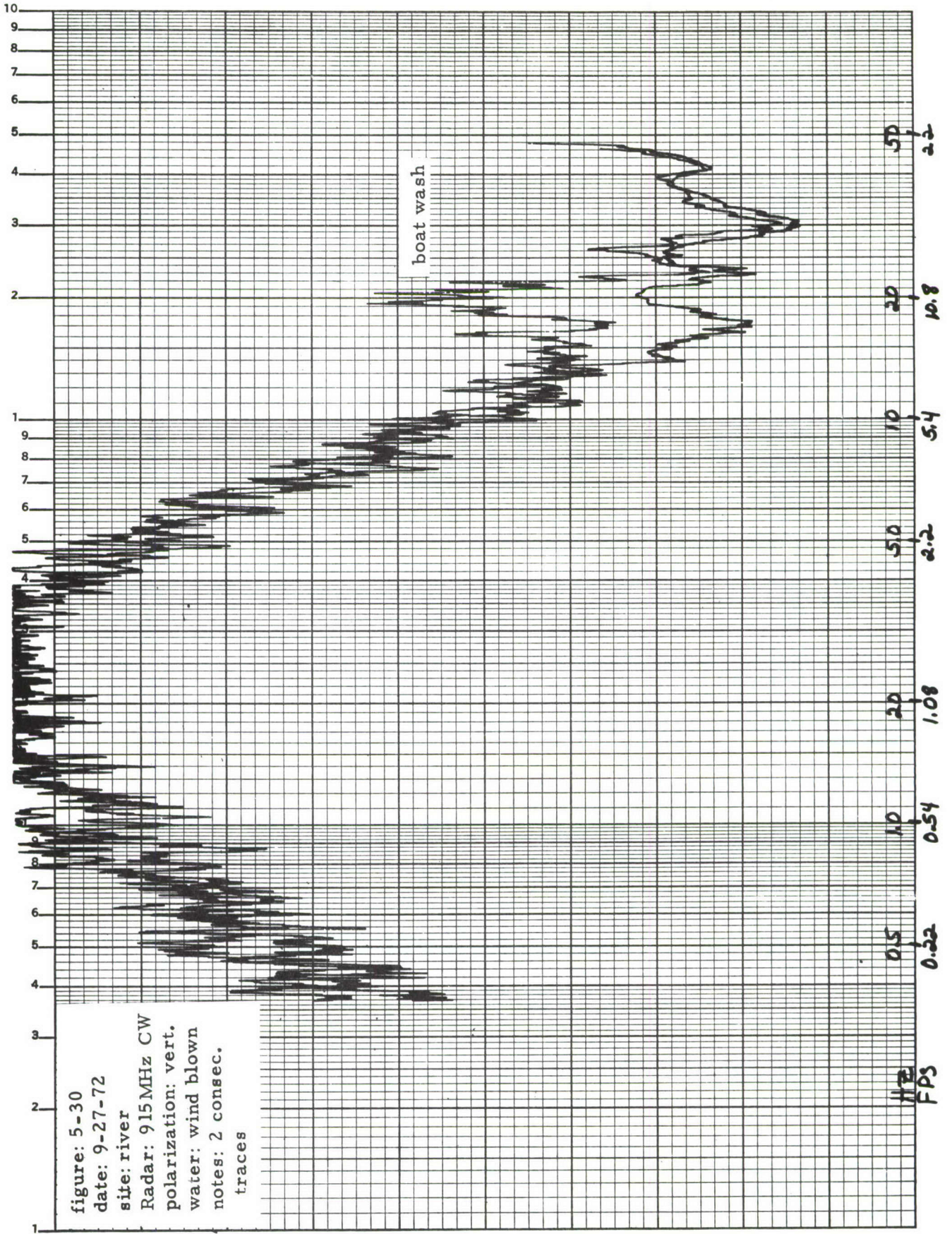
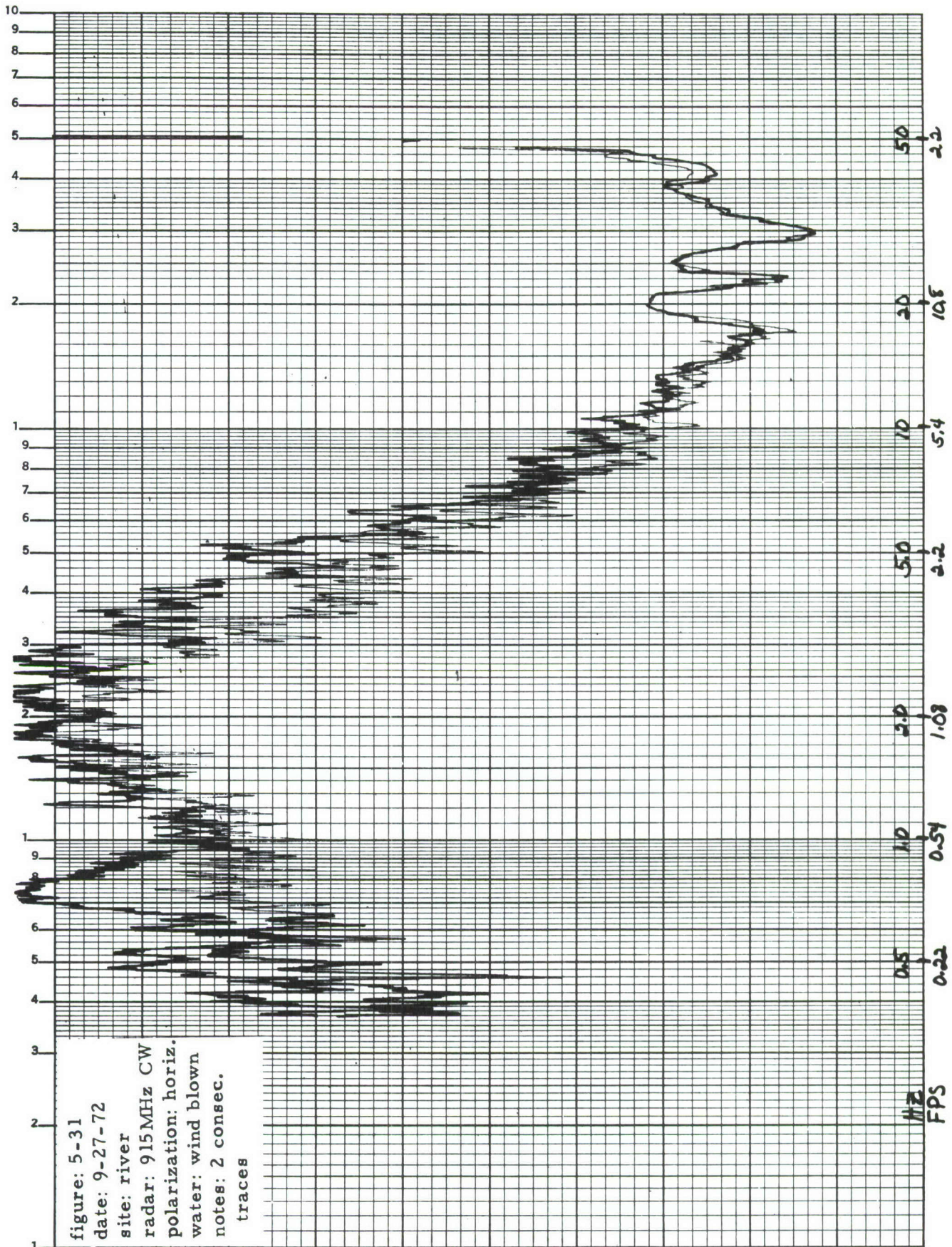


figure: 5-27  
 date: 9-20-72  
 site: river  
 radar: 915MHz CW  
 polarization: horiz.  
 water: same as 5-26









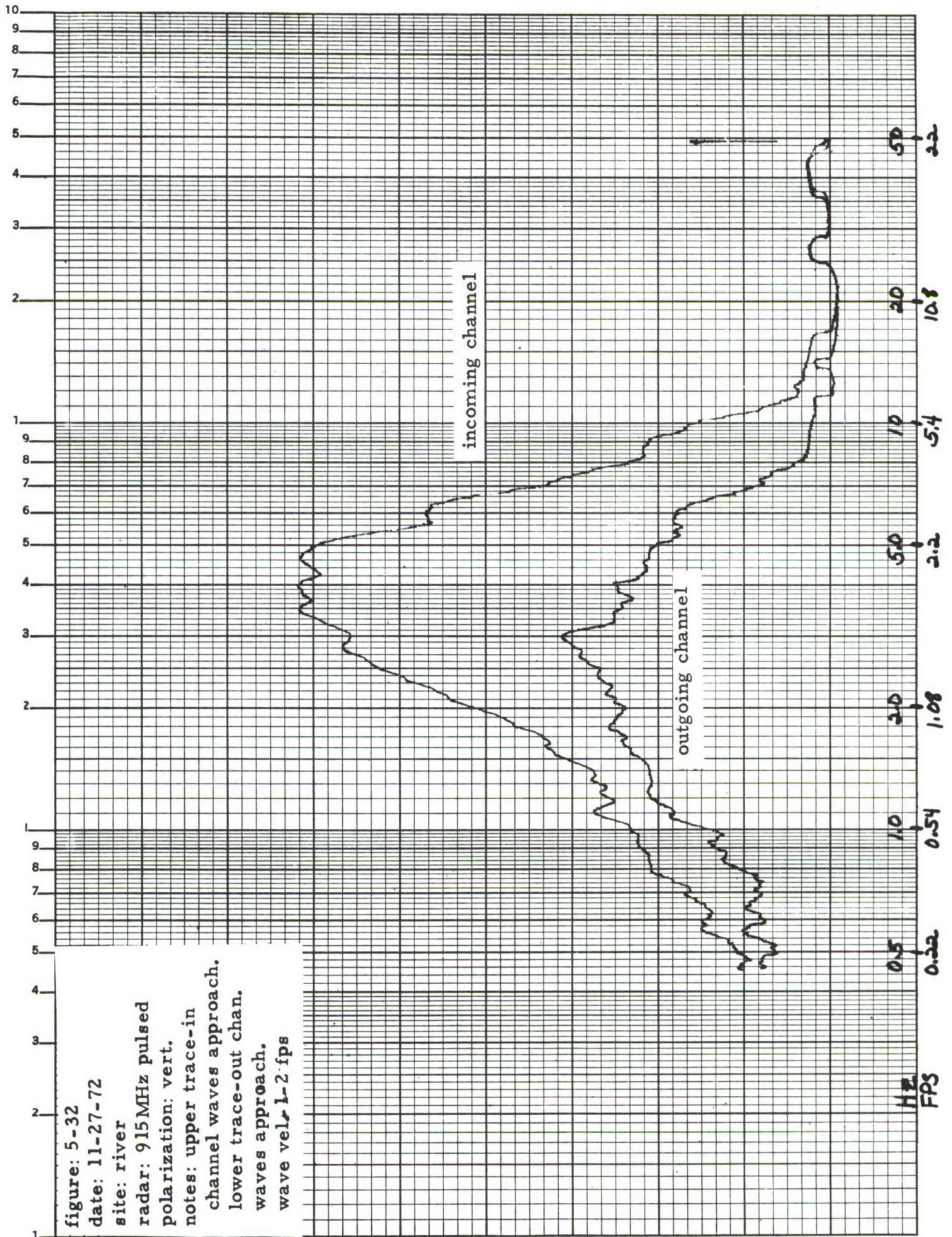


figure: 5-32  
 date: 11-27-72  
 site: river  
 radar: 915MHz pulsed  
 polarization: vert.  
 notes: upper trace-in  
 channel waves approach.  
 lower trace-out chan.  
 waves approach.  
 wave vel. 1-2 fps

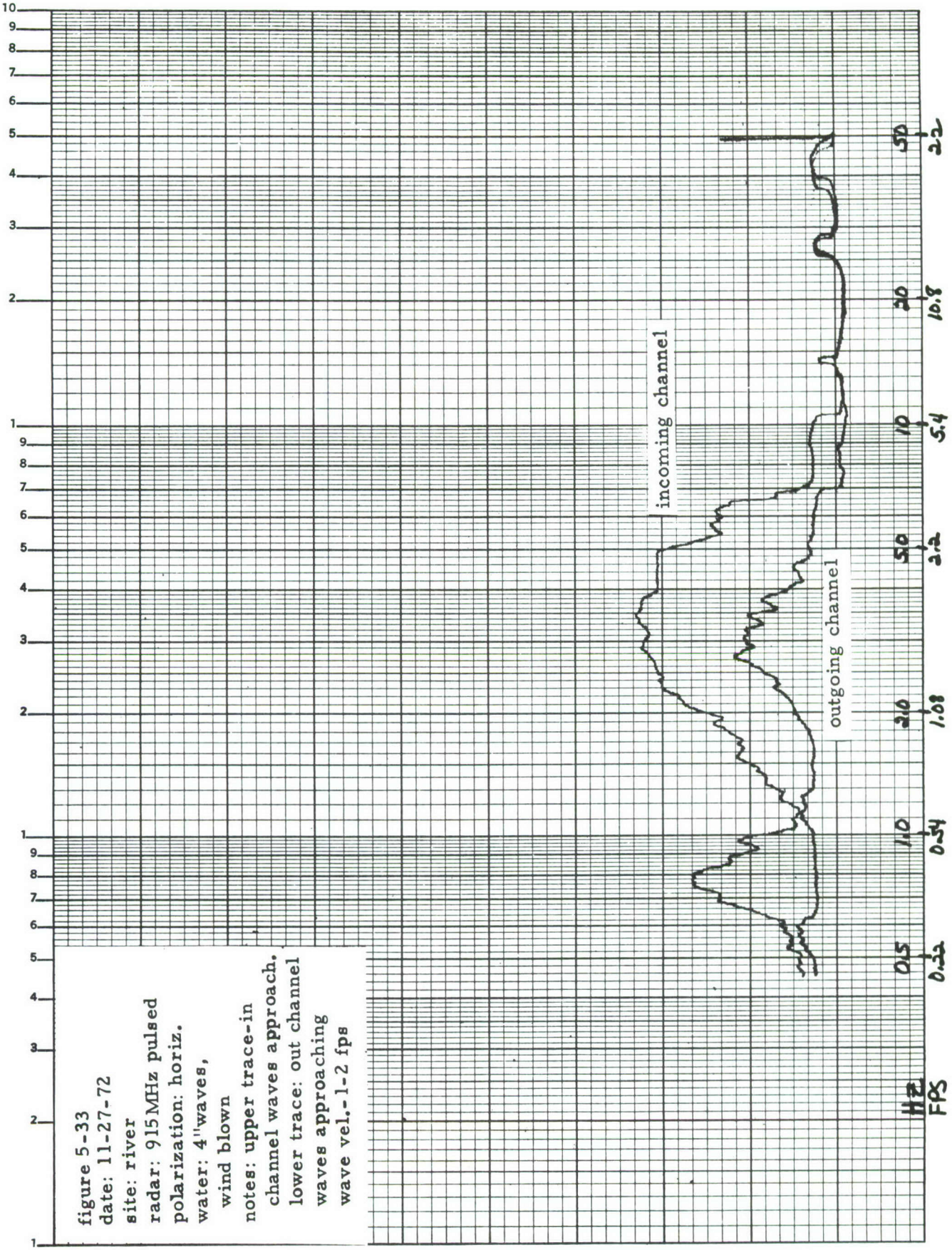


figure 5-33  
 date: 11-27-72  
 site: river  
 radar: 915 MHz pulsed  
 polarization: horiz.  
 water: 4" waves,  
 wind blown  
 notes: upper trace-in  
 channel waves approach,  
 lower trace: out channel  
 waves approaching  
 wave vel.- 1-2 fps

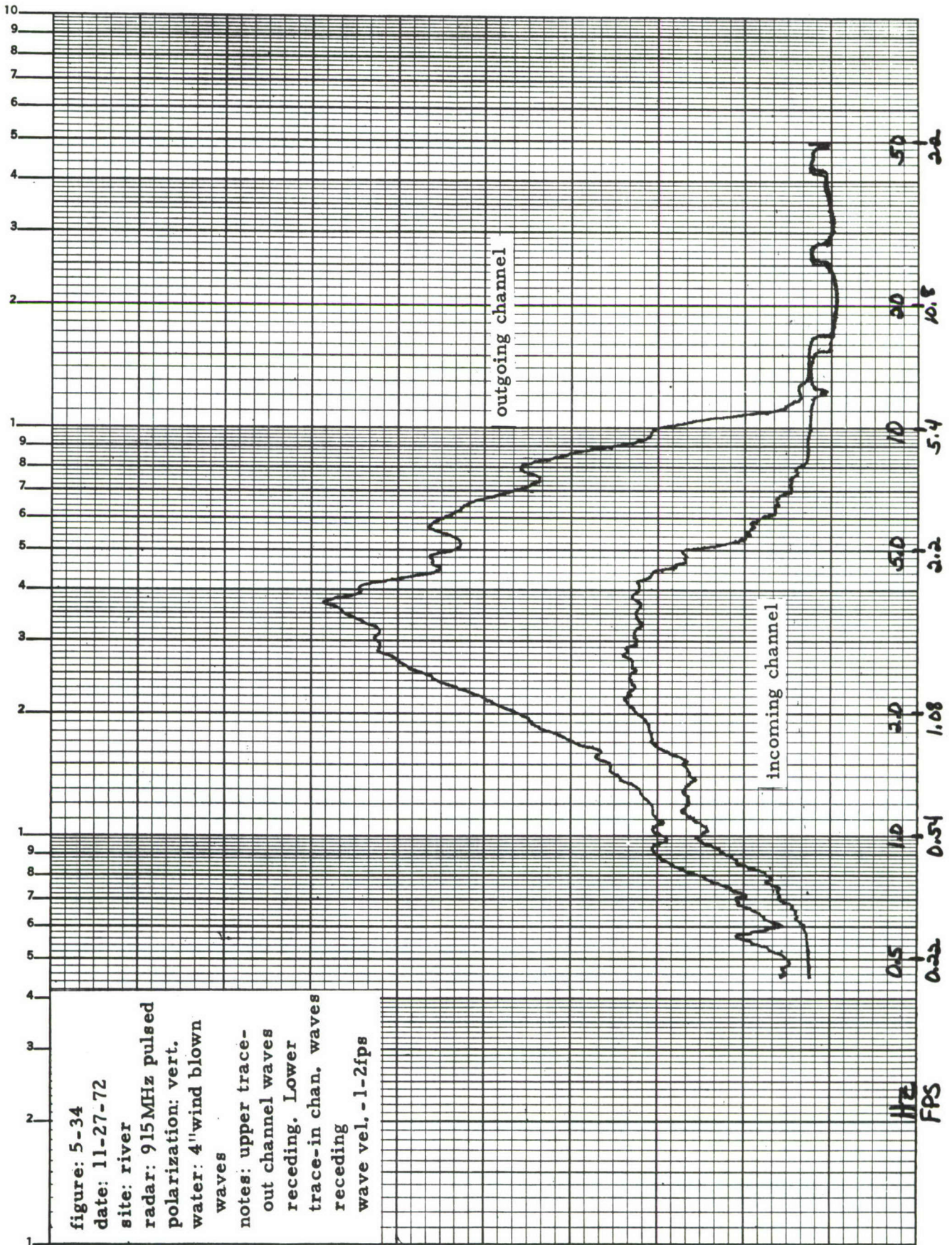
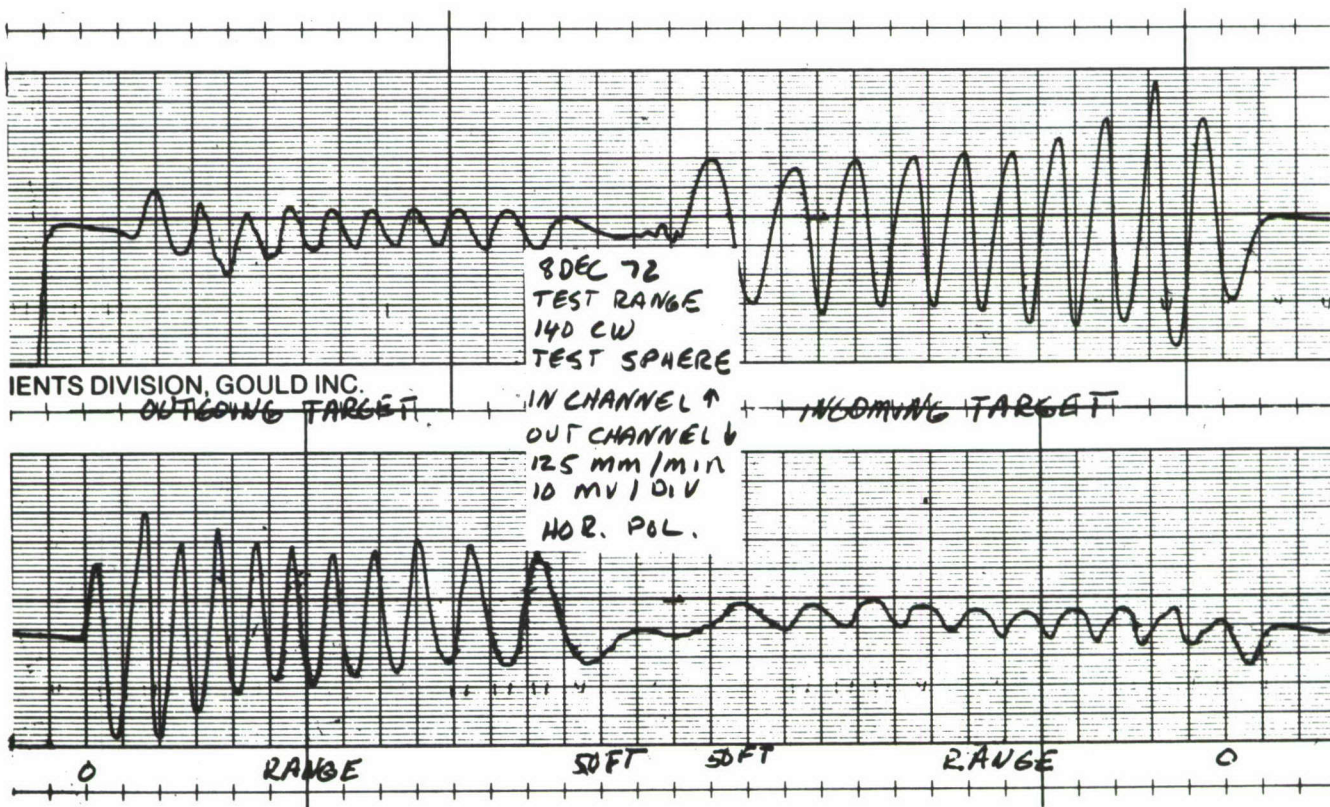
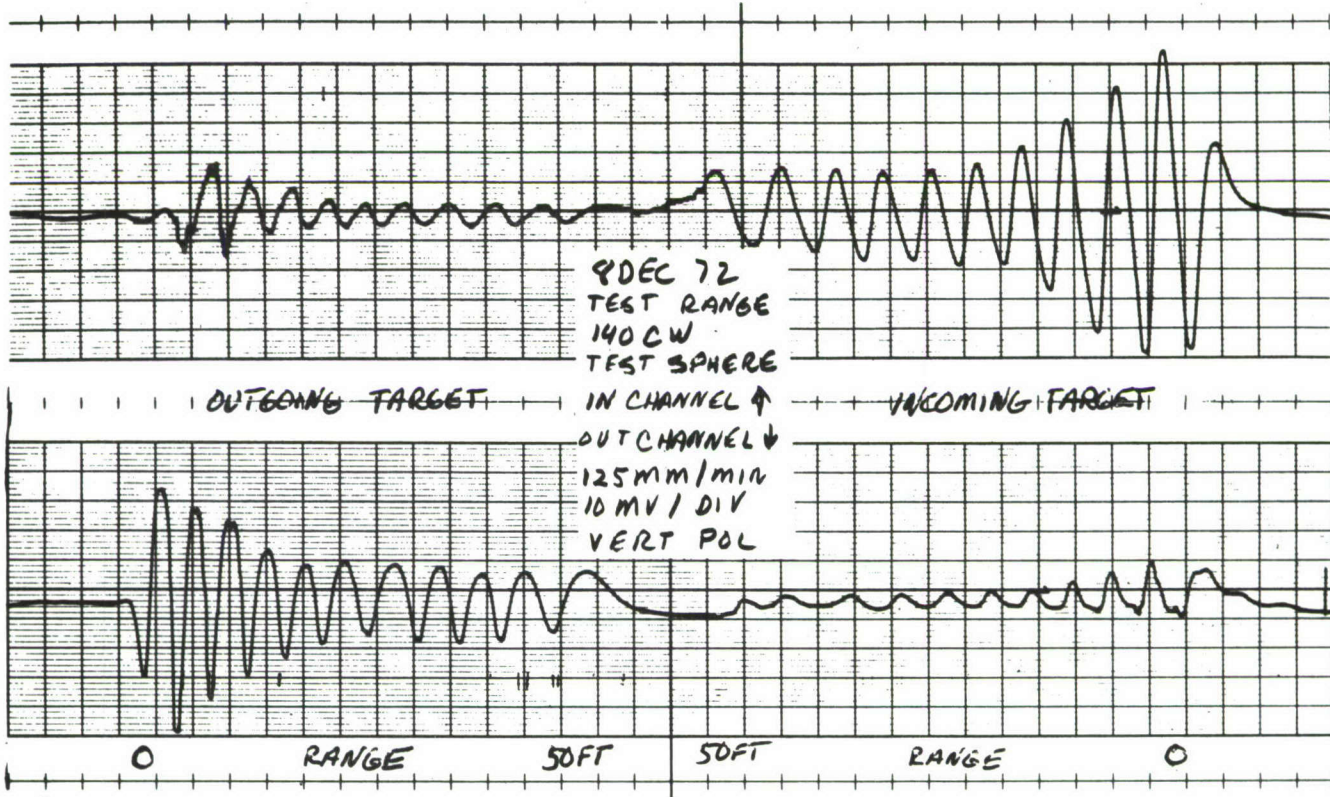
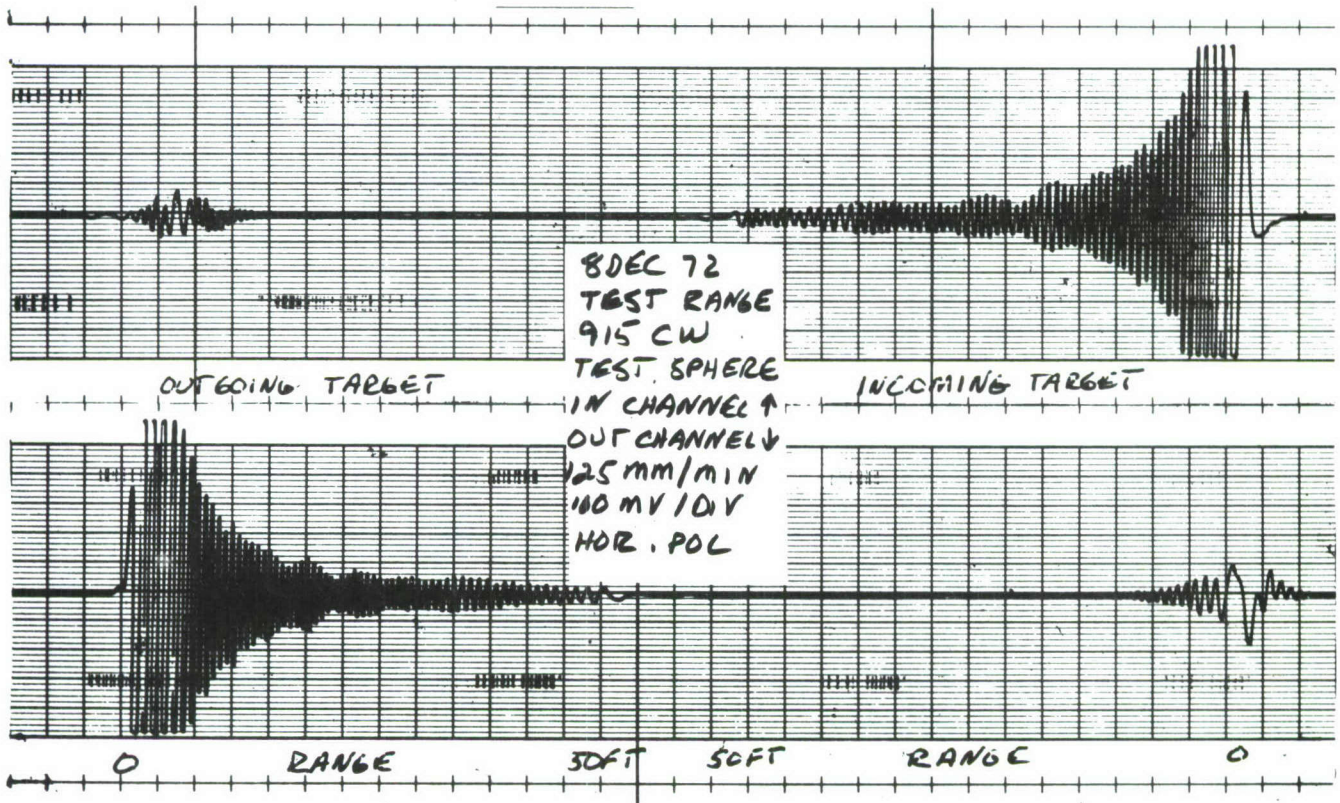
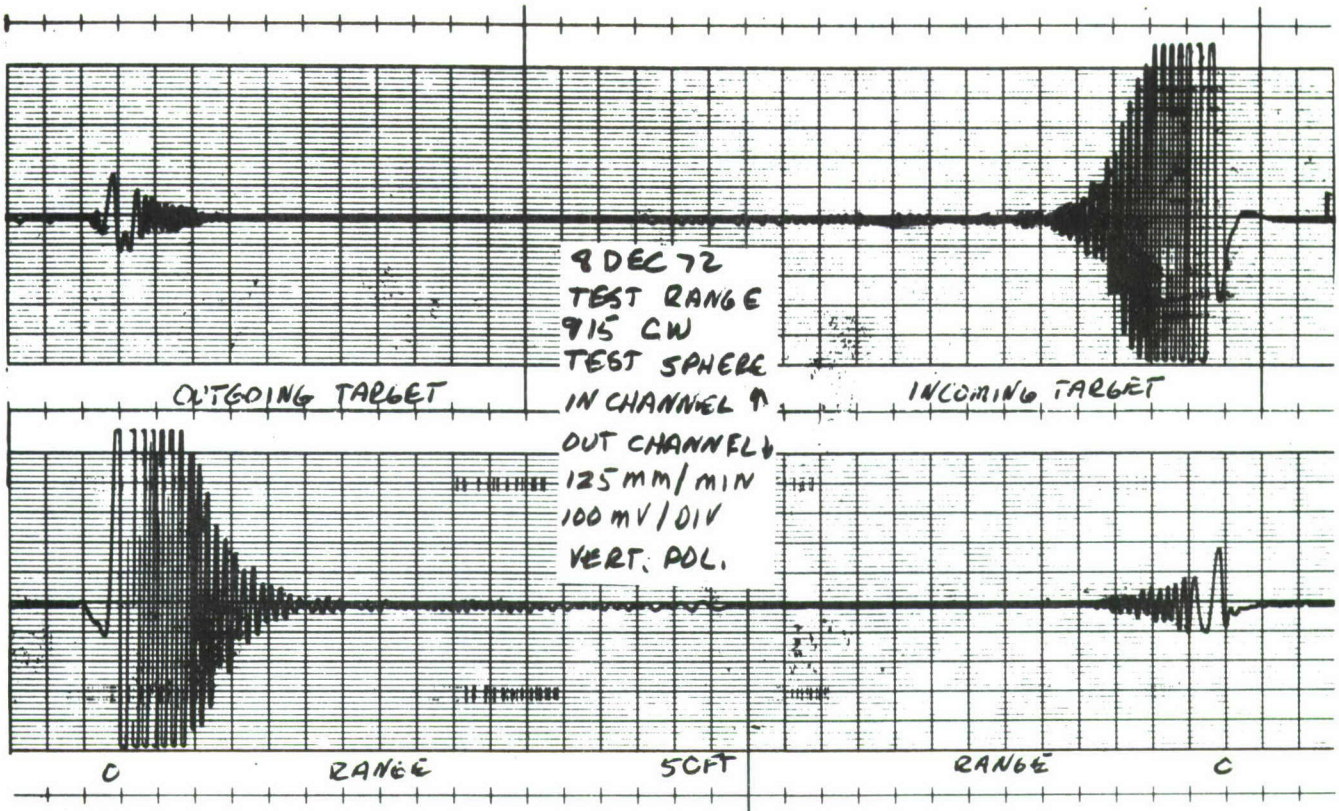
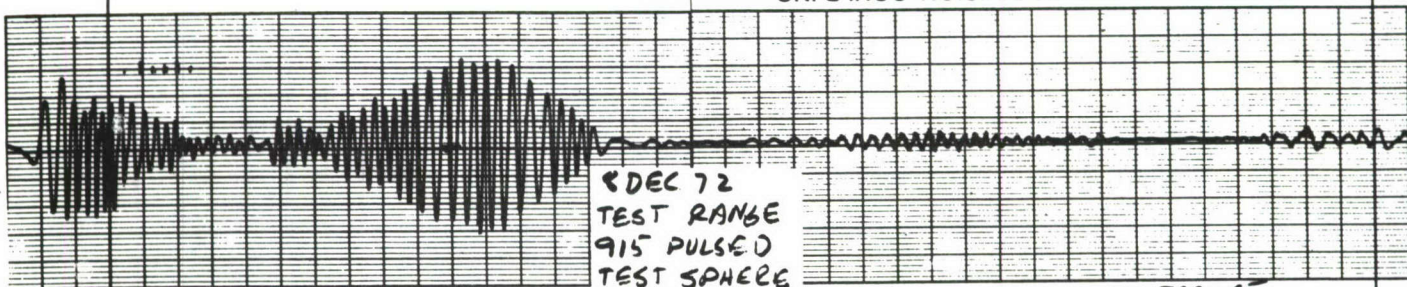


figure: 5-34  
 date: 11-27-72  
 site: river  
 radar: 915 MHz pulsed  
 polarization: vert.  
 water: 4" wind blown  
 waves  
 notes: upper trace-  
 out channel waves  
 receding. Lower  
 trace-in chan. waves  
 receding  
 wave vel. - 1-2fps







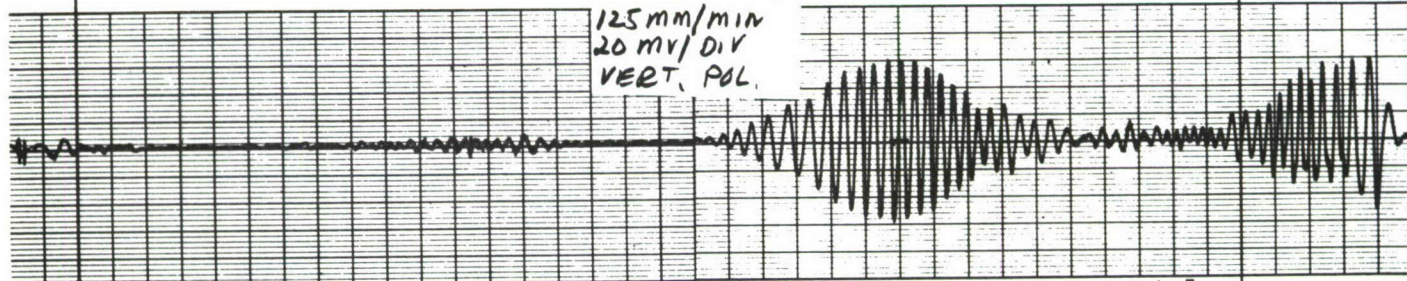


OUTGOING TARGET

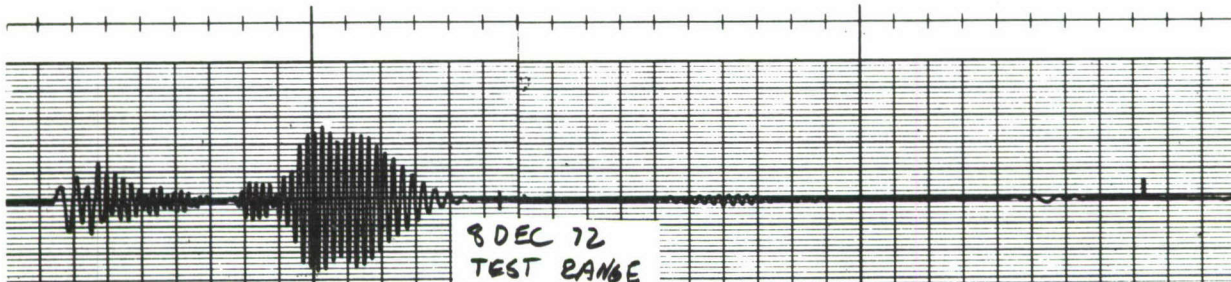
INCOMING TARGET

8 DEC 72  
 TEST RANGE  
 915 PULSED  
 TEST SPHERE  
 OUT CHANNEL ↑  
 IN CHANNEL ↓

125 MM/MIN  
 20 MV/DIV  
 VERT. POL.



0 RANGE 20FT 20FT RANGE 0

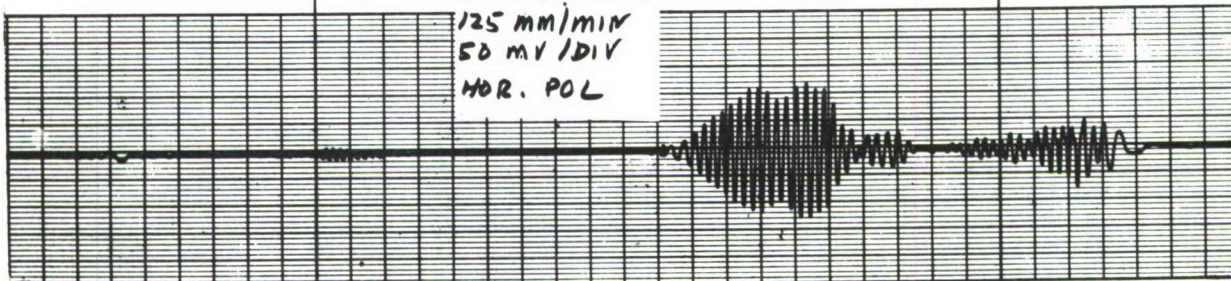


OUTGOING TARGET

INCOMING TARGET

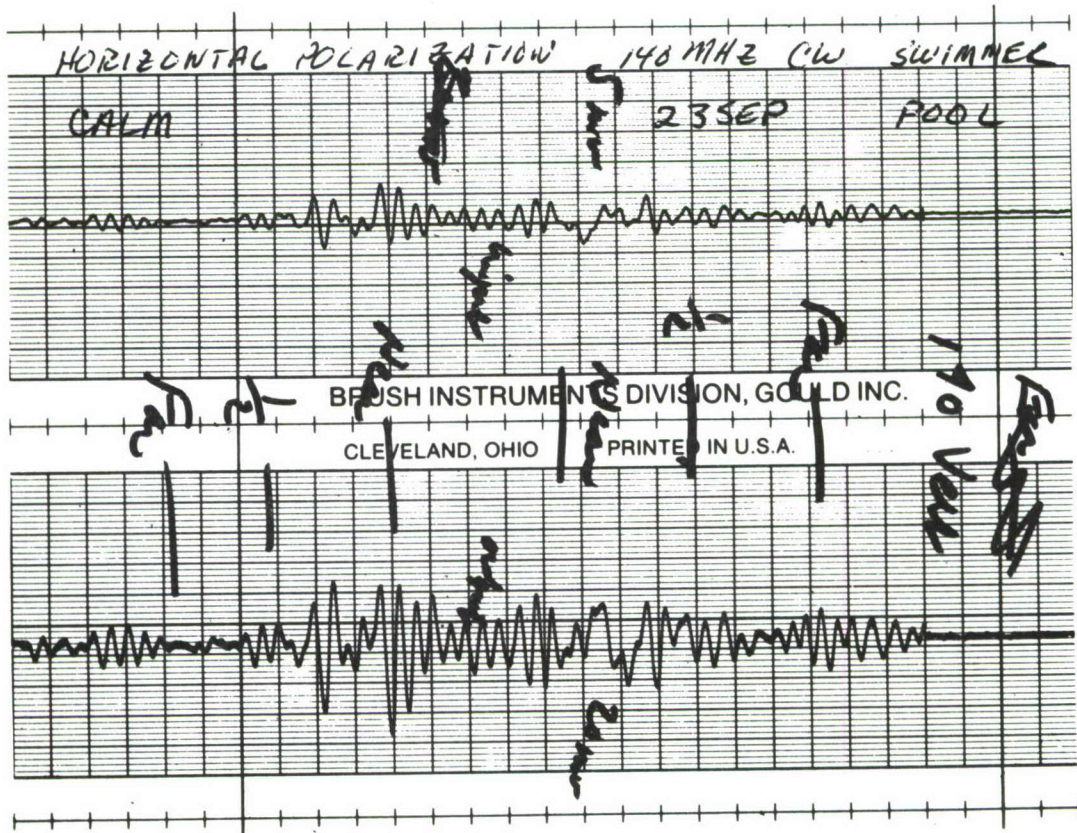
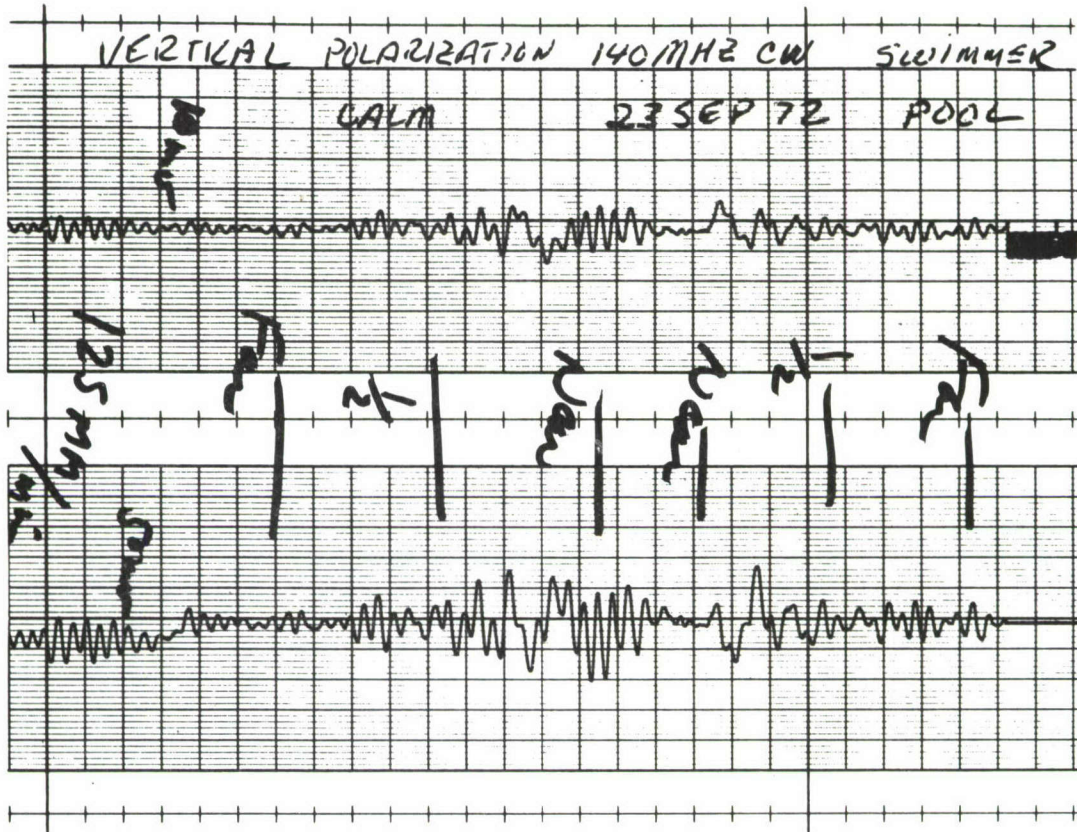
8 DEC 72  
 TEST RANGE  
 915 PULSED  
 TEST SPHERE  
 OUT CHANNEL ↑  
 IN CHANNEL ↓

125 MM/MIN  
 50 MV/DIV  
 HOR. POL.



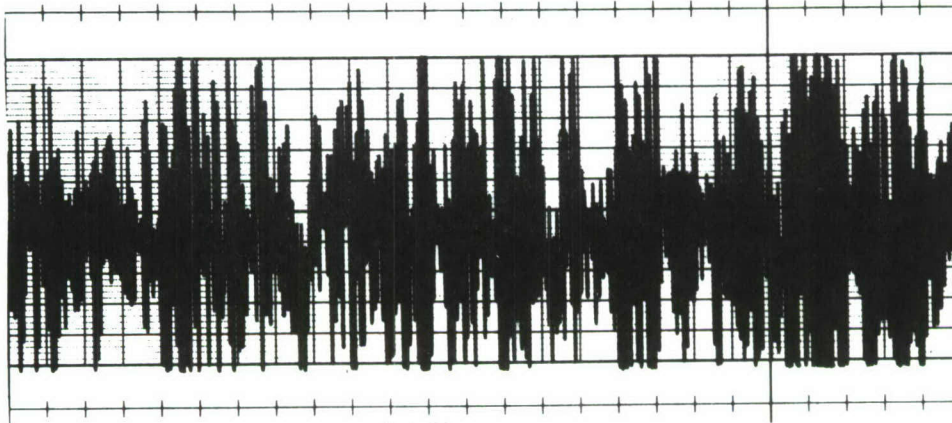
BRUSH INSTRUMENTS DIVISION, GOULD INC. 20FT RANGE 20FT 0



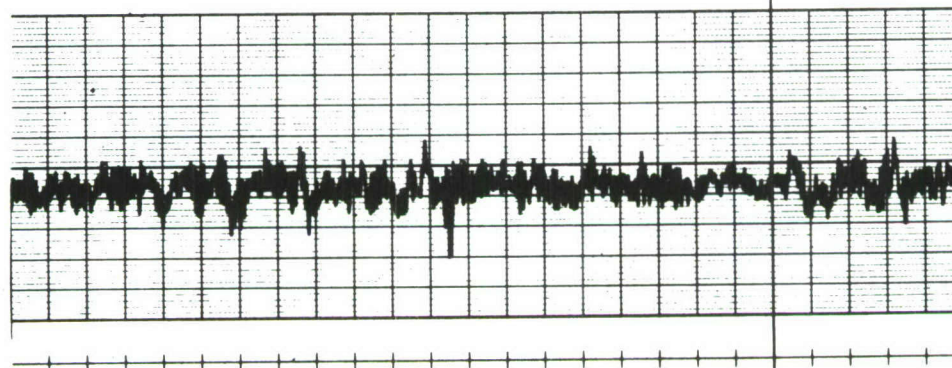


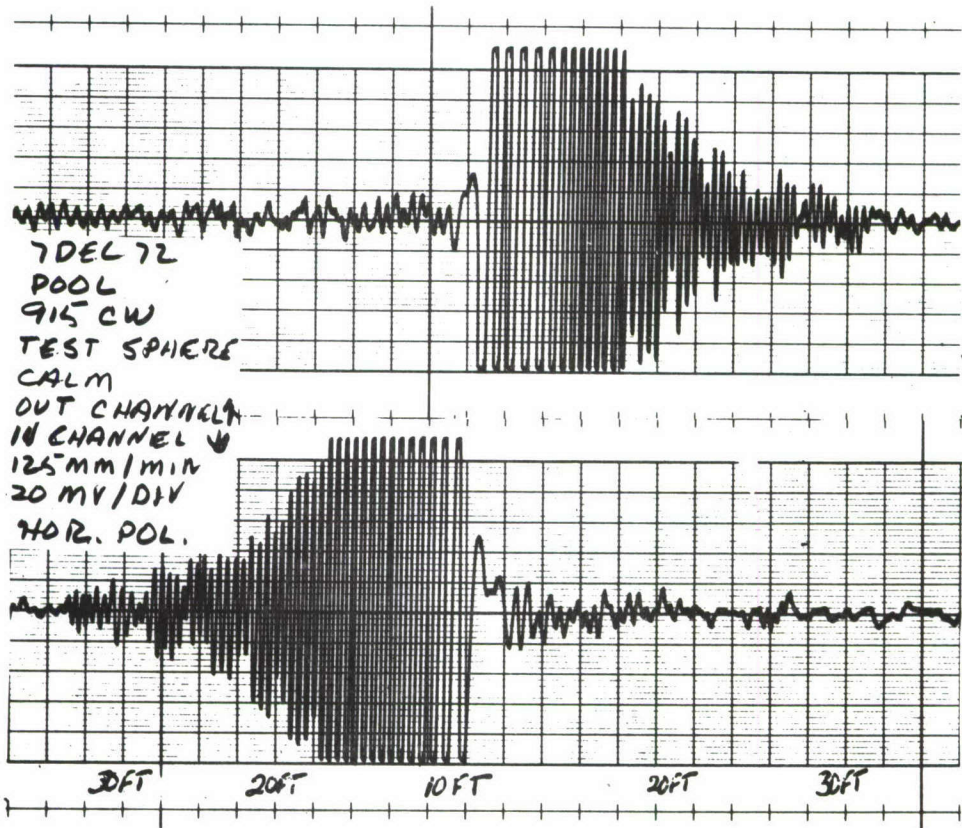
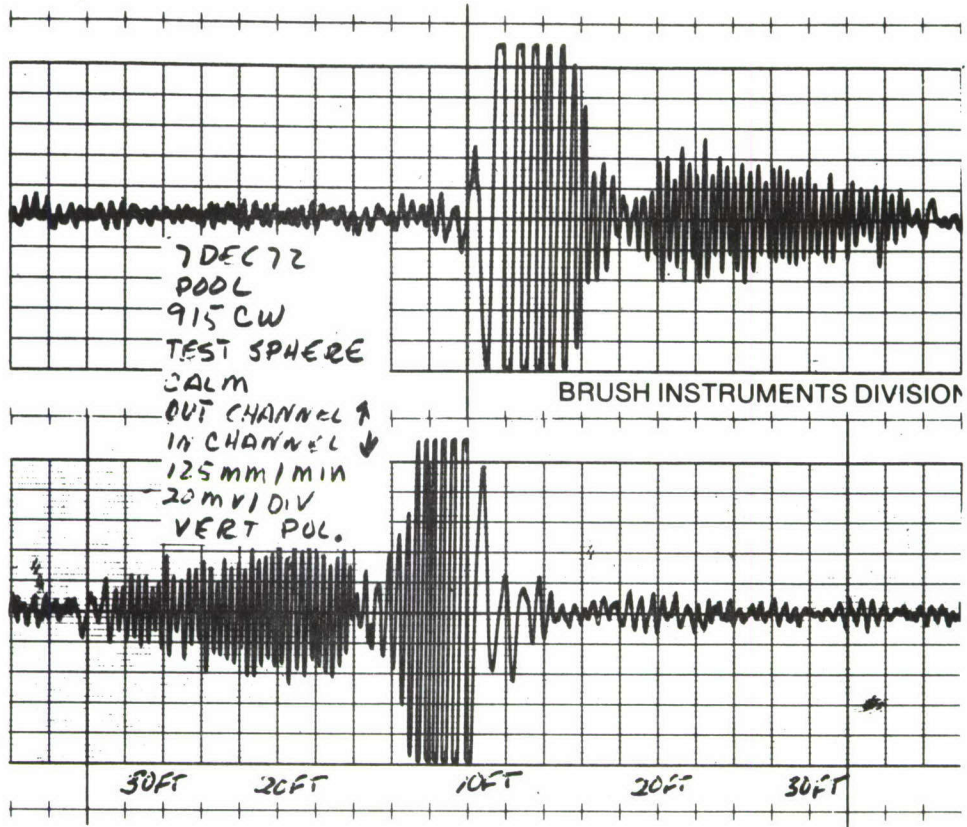
BRUSH INSTRUMENTS DIVISION, GOLD INC.  
 CLEVELAND, OHIO PRINTED IN U.S.A.

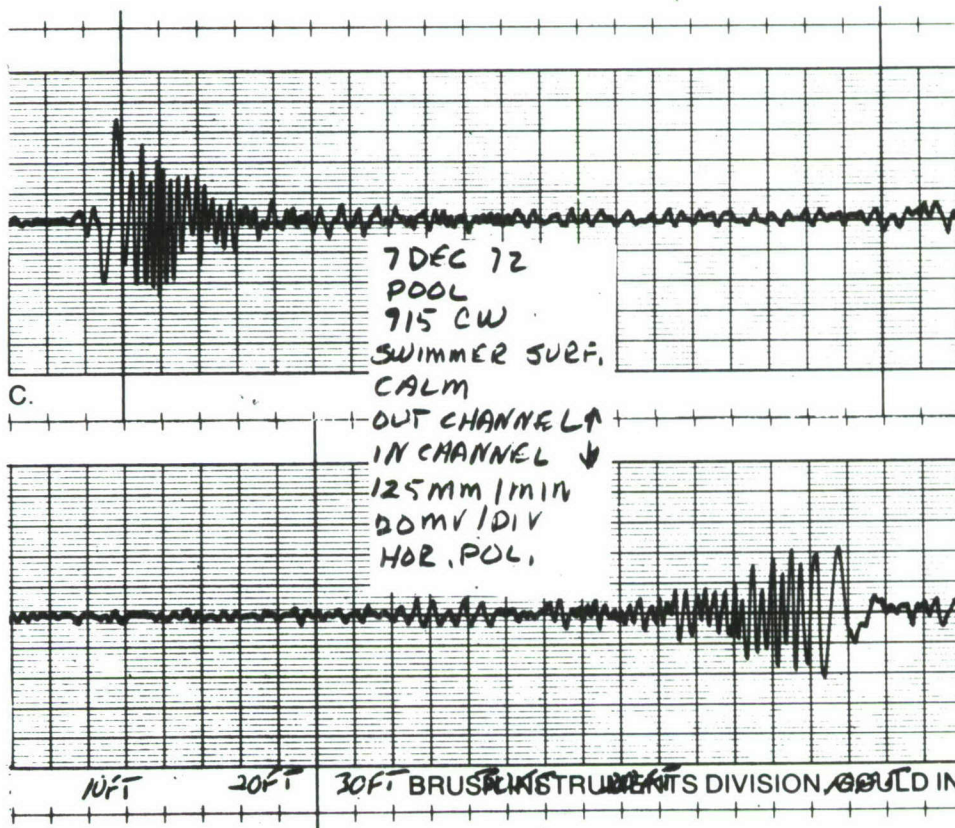
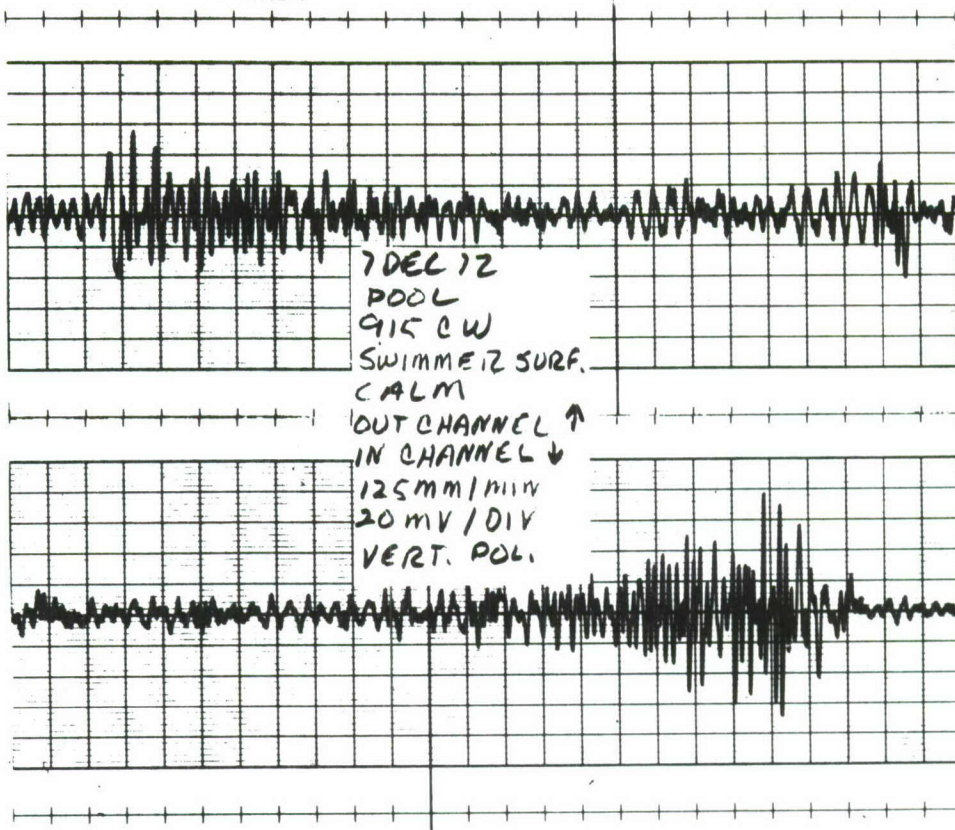
140 MHz	CLUTTER RETURN	23 SEP 72
VERTICAL	POLARIZATION	POOL
10MHz / DIV	25mm / MIN	4" WAVES
	241	242
		243

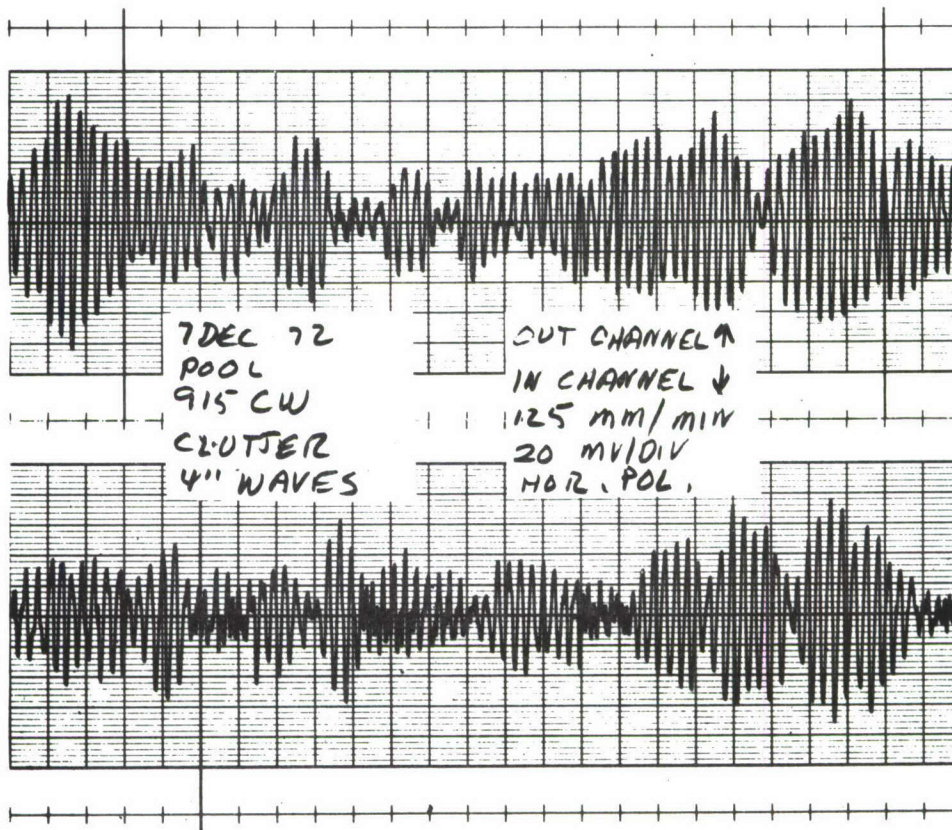
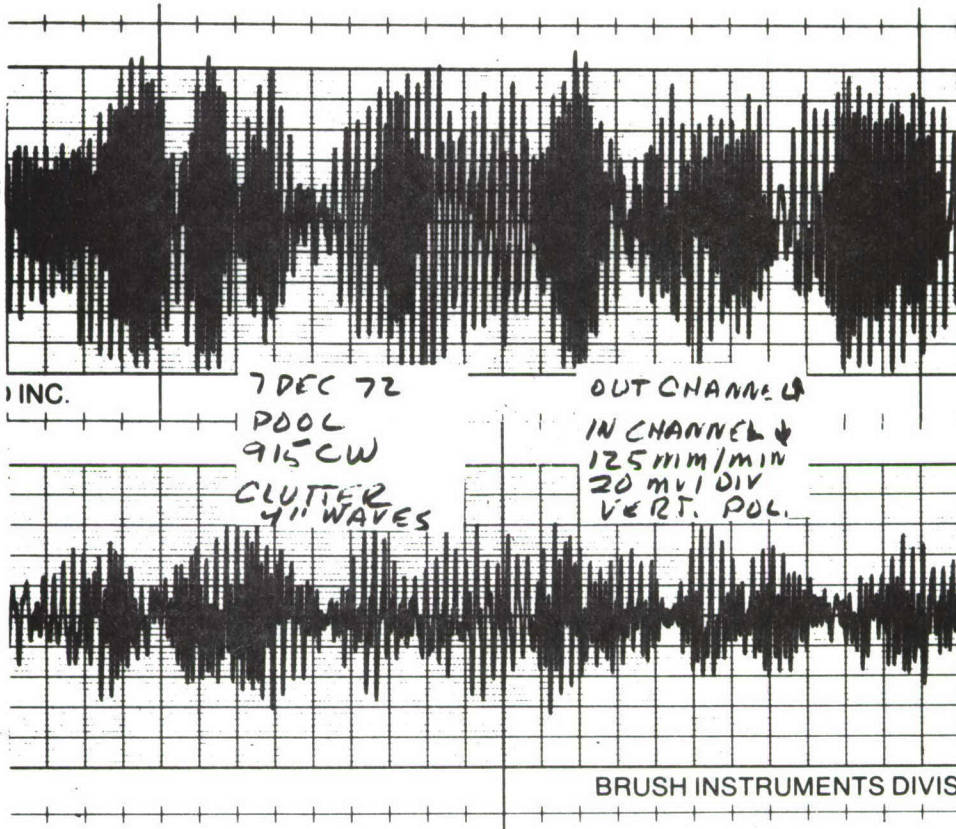


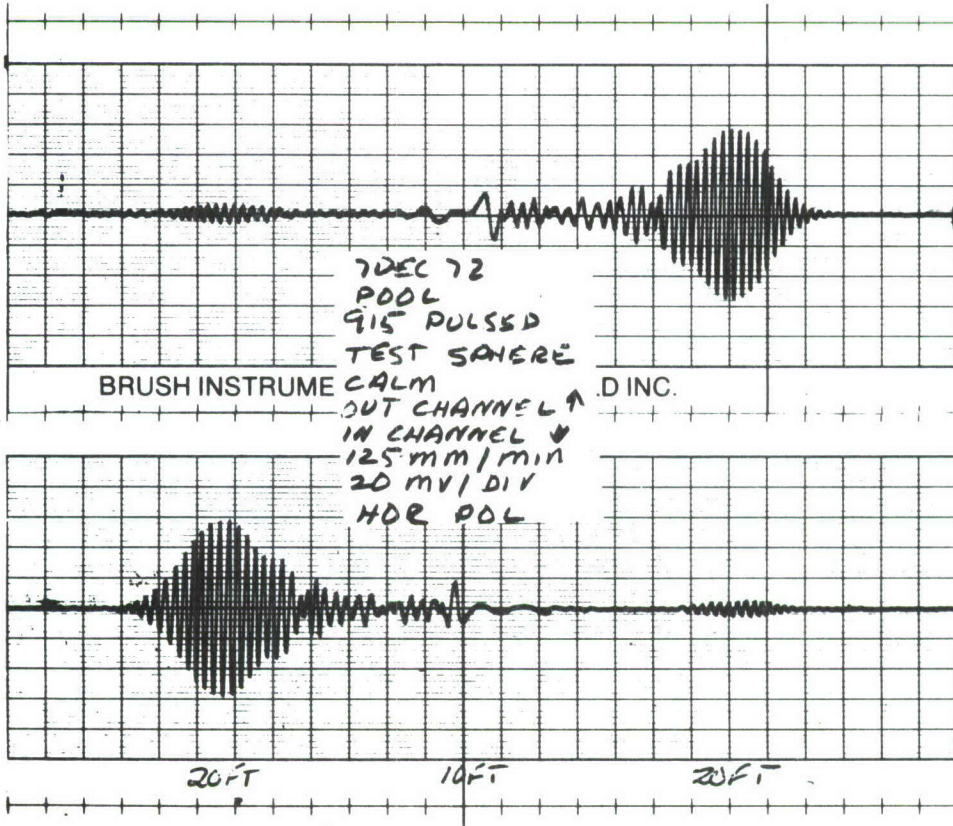
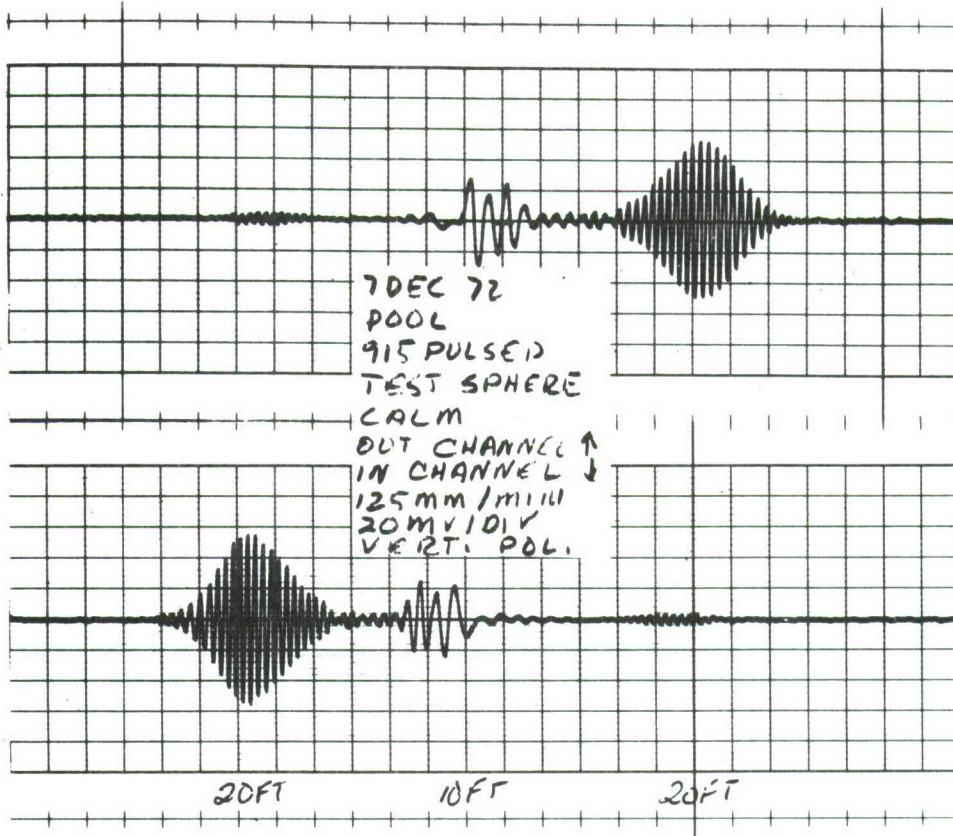
140 MHz	CLUTTER RETURN	23 SEP 72
HORIZONTAL	POLARIZATION	POOL
10MHz / DIV	25mm / MIN	4" WAVES
	241	0542
		242

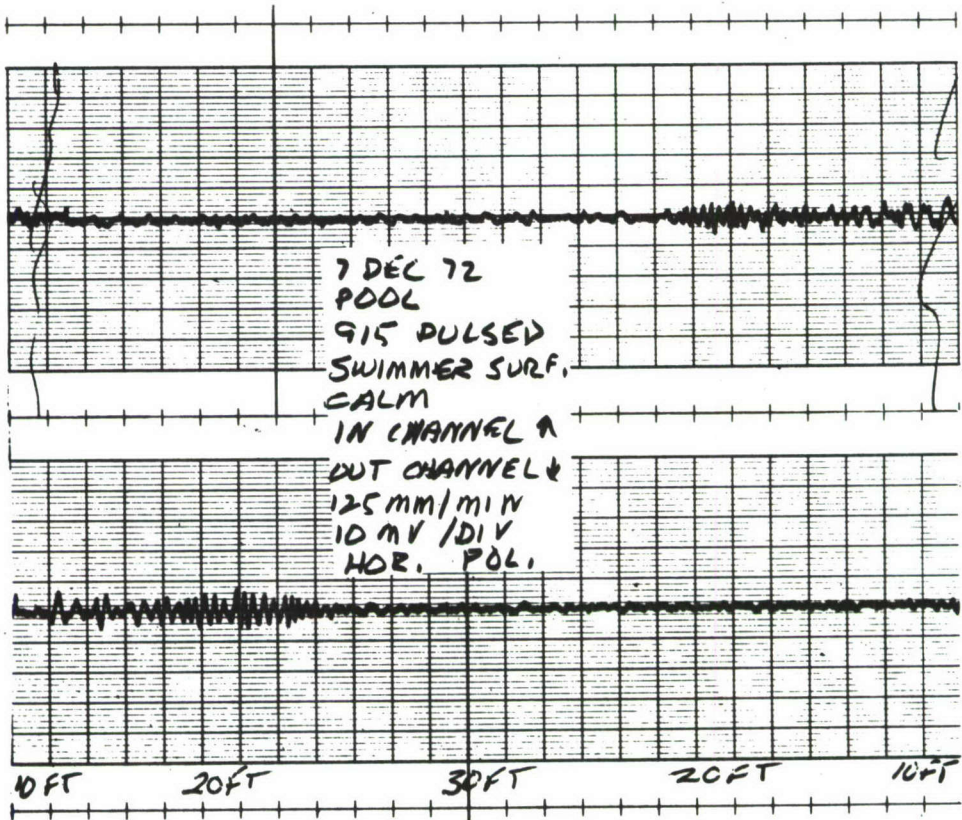
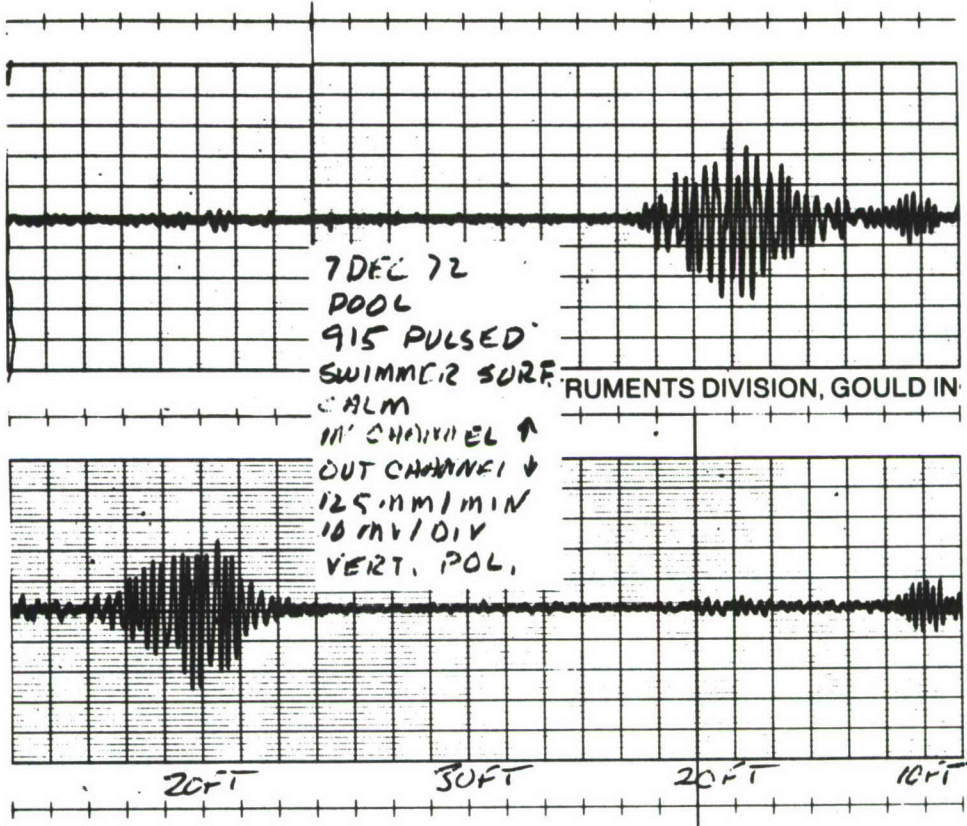


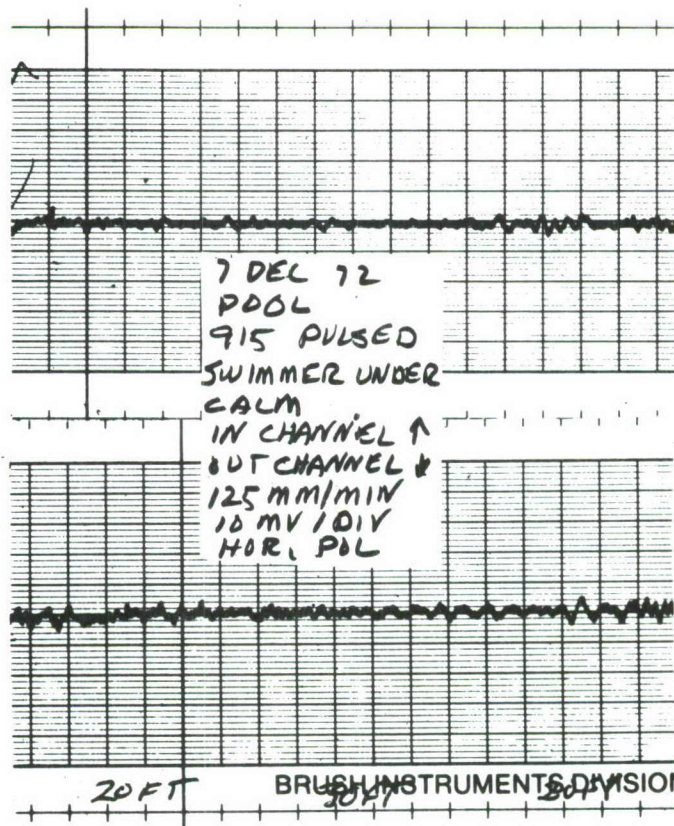
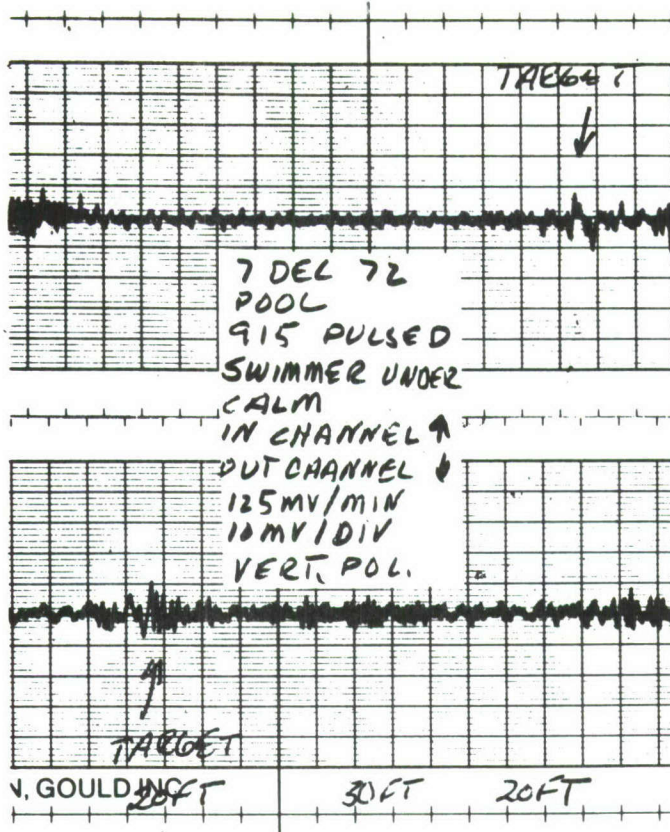


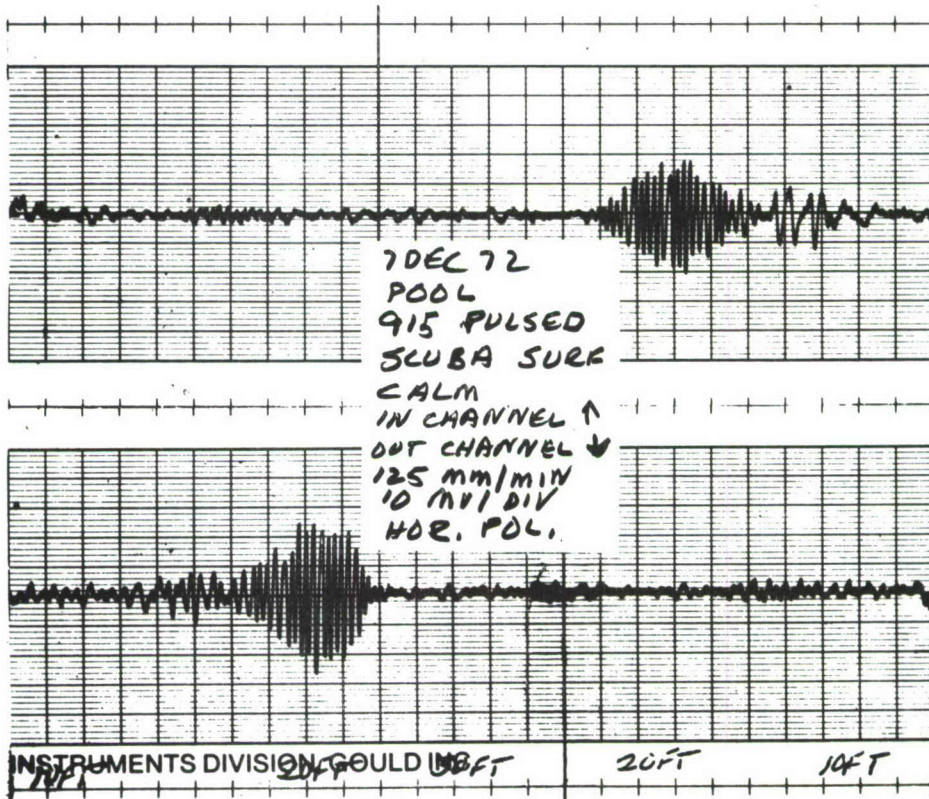
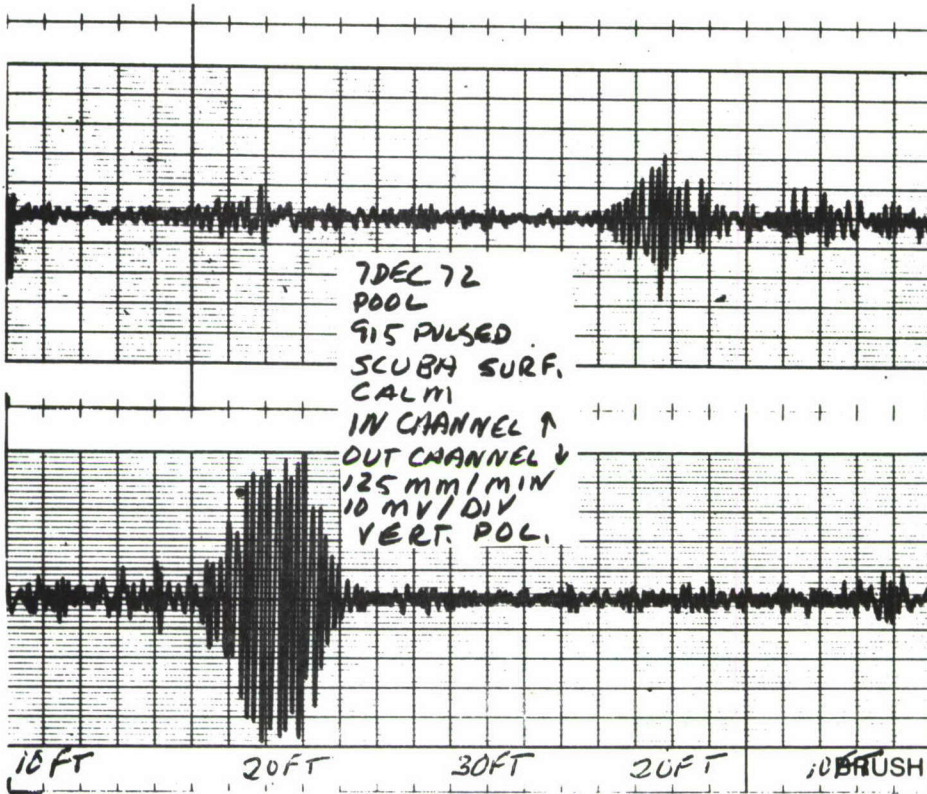


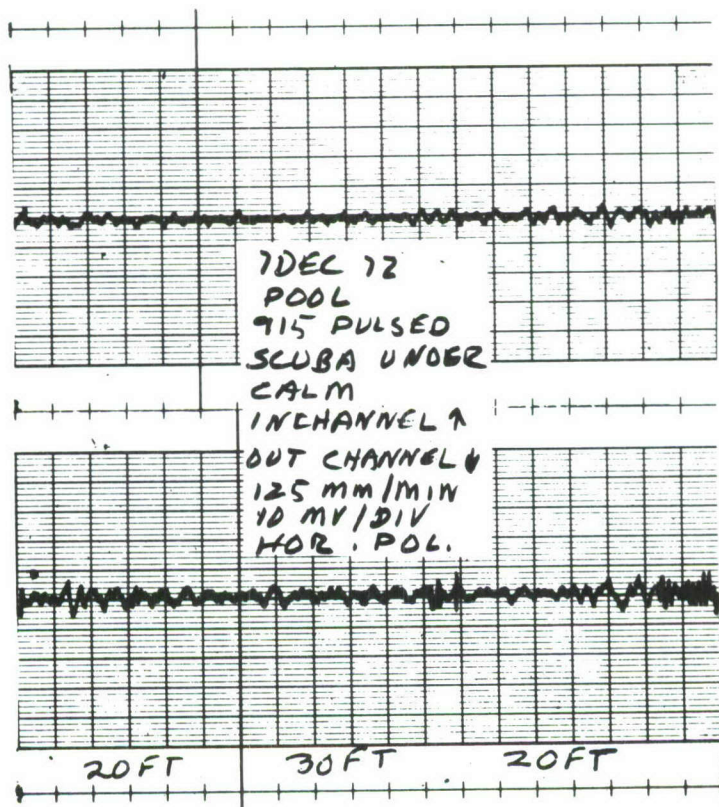
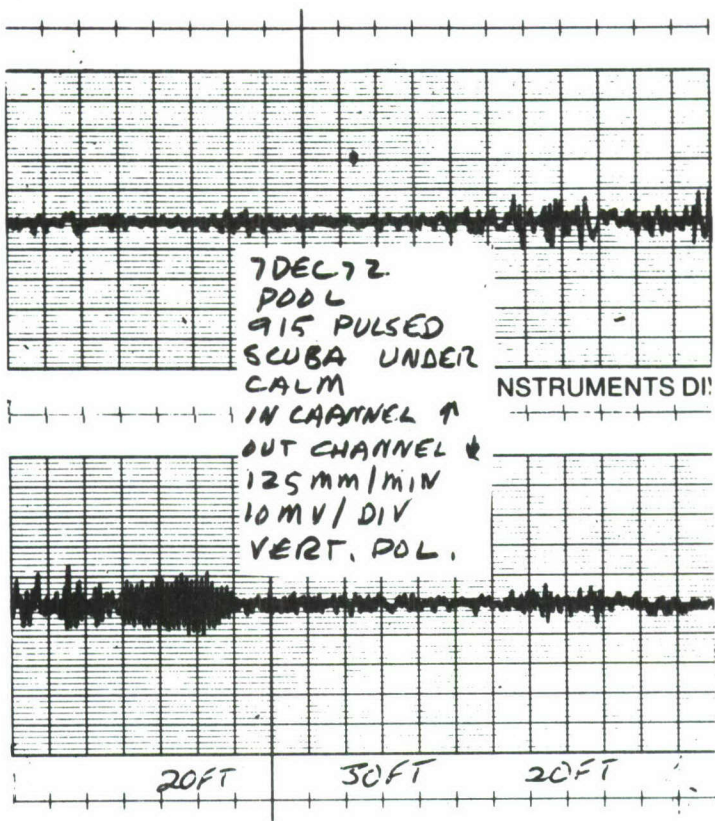


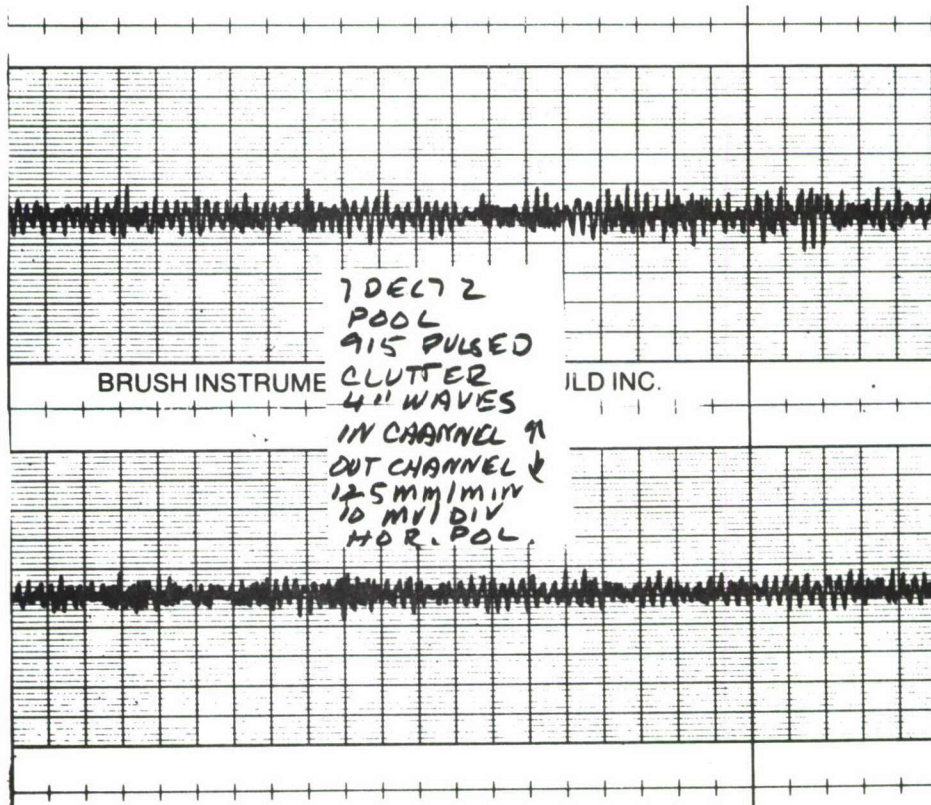
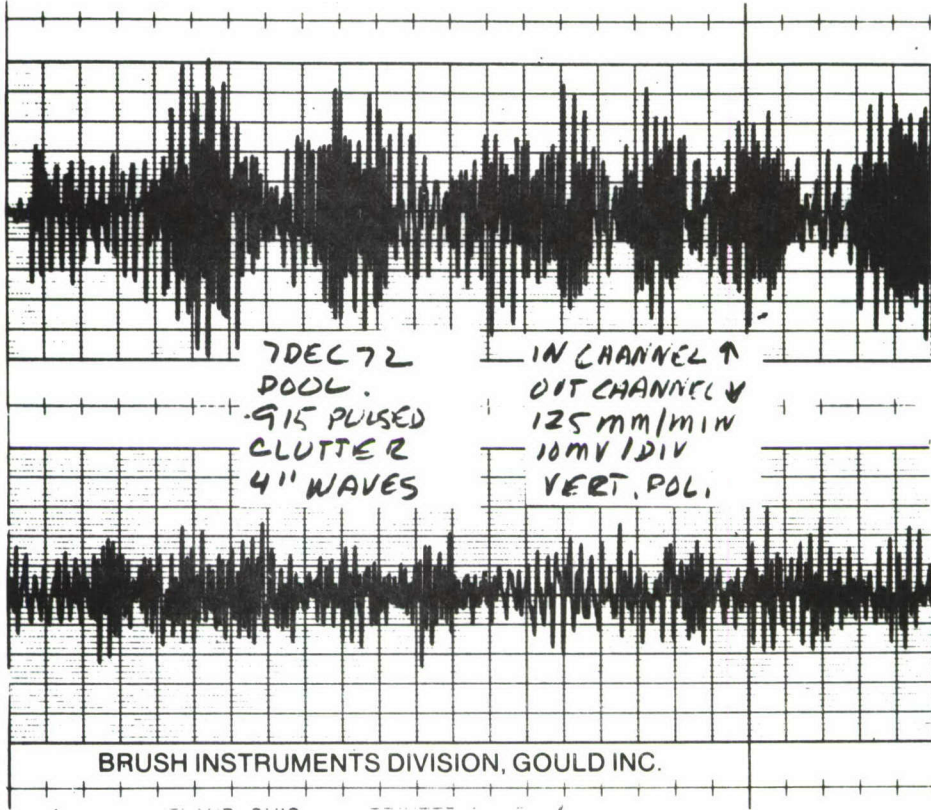


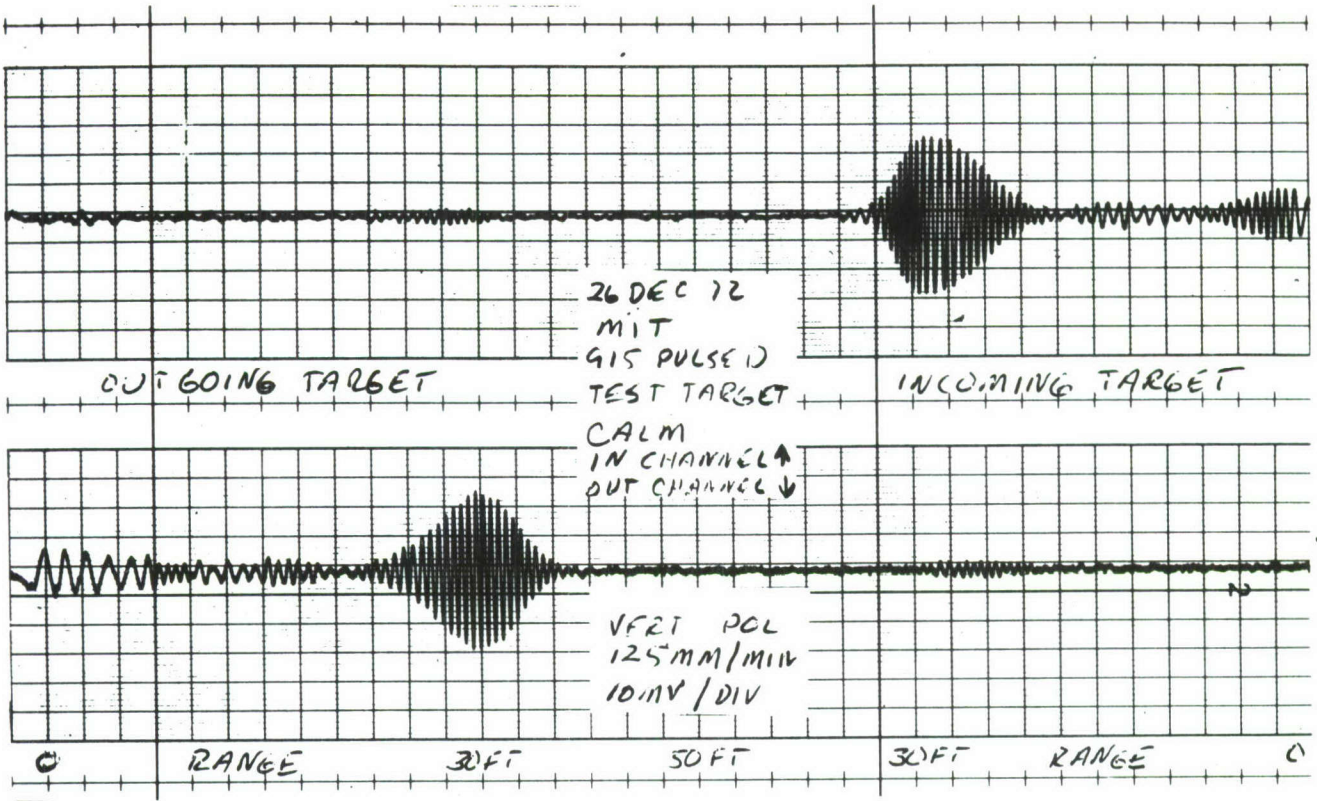


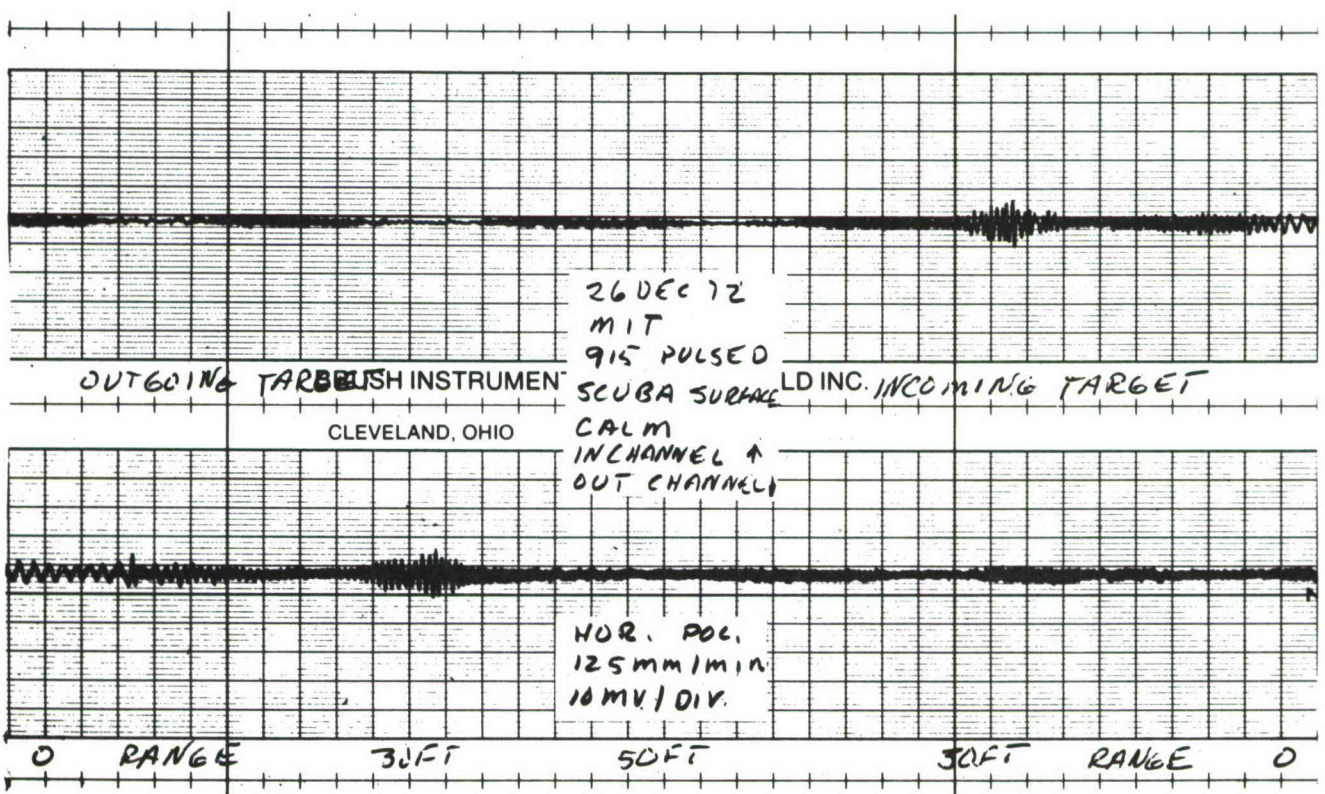
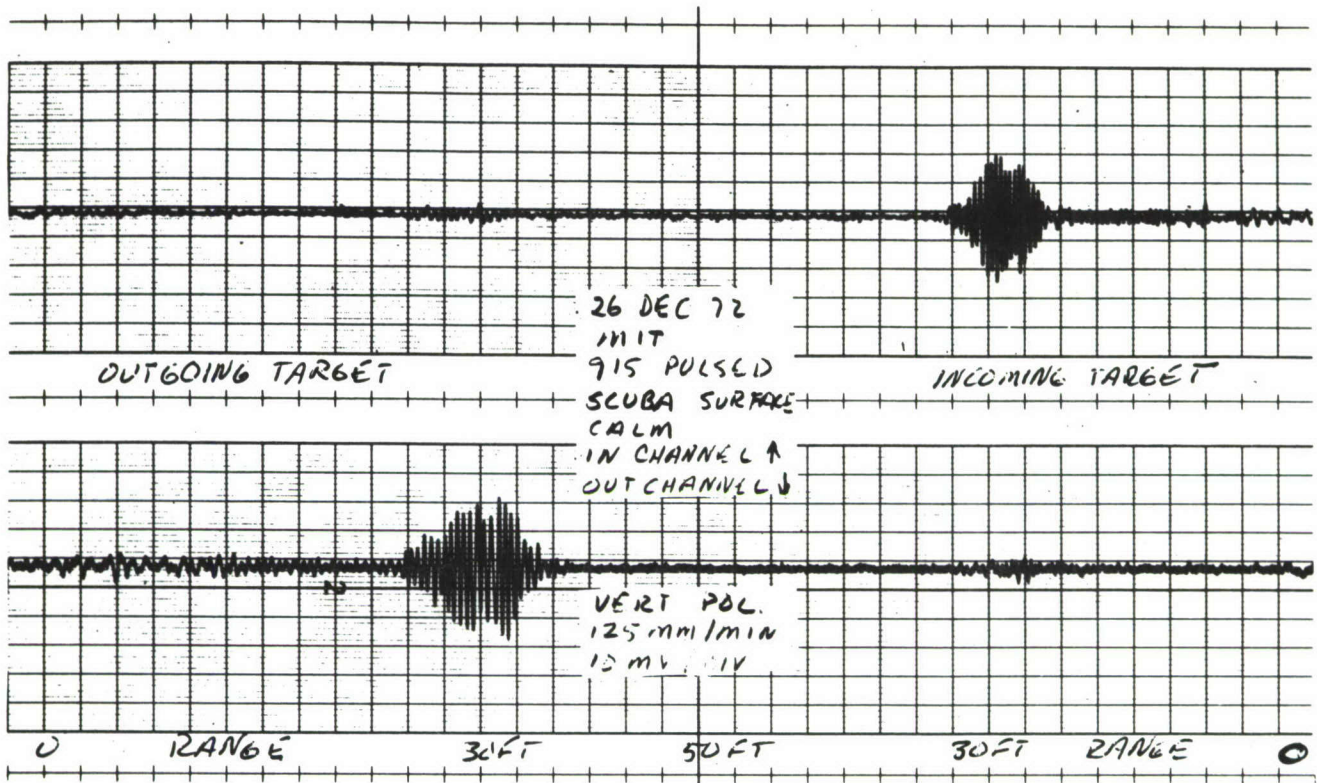


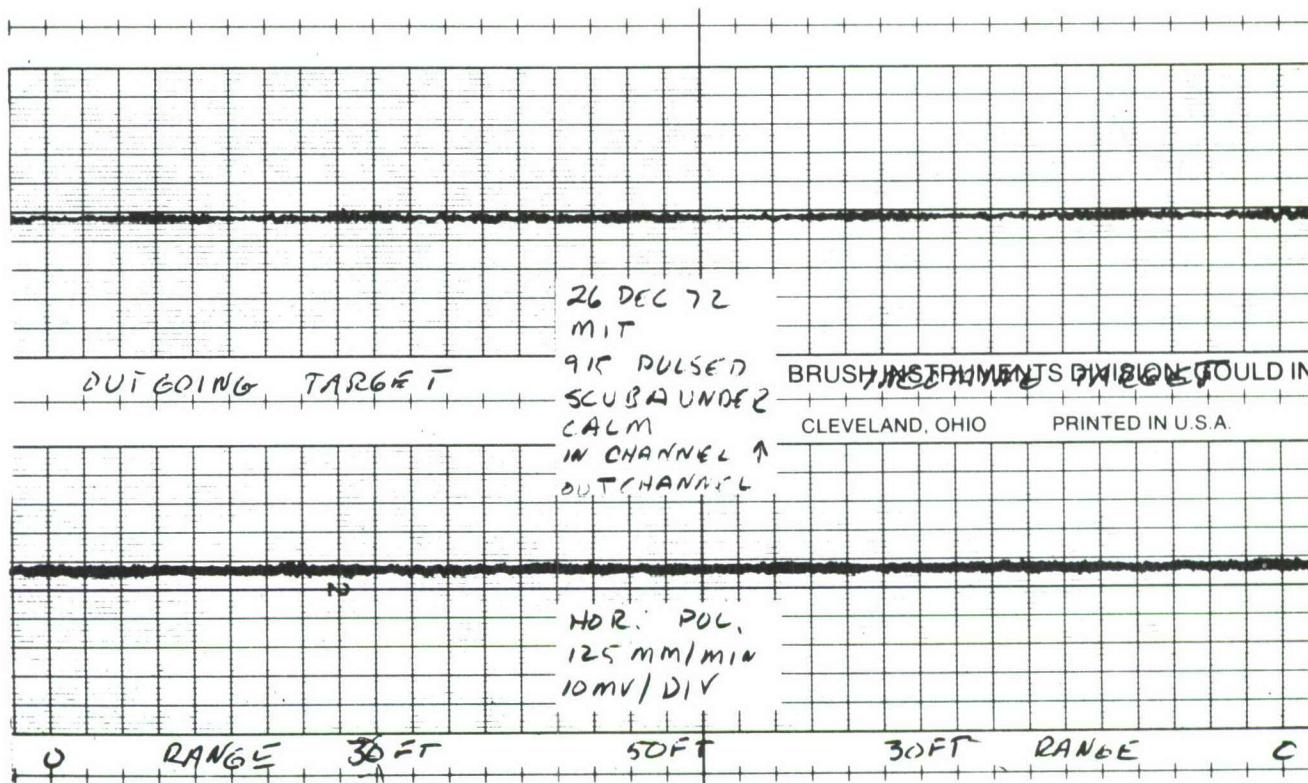
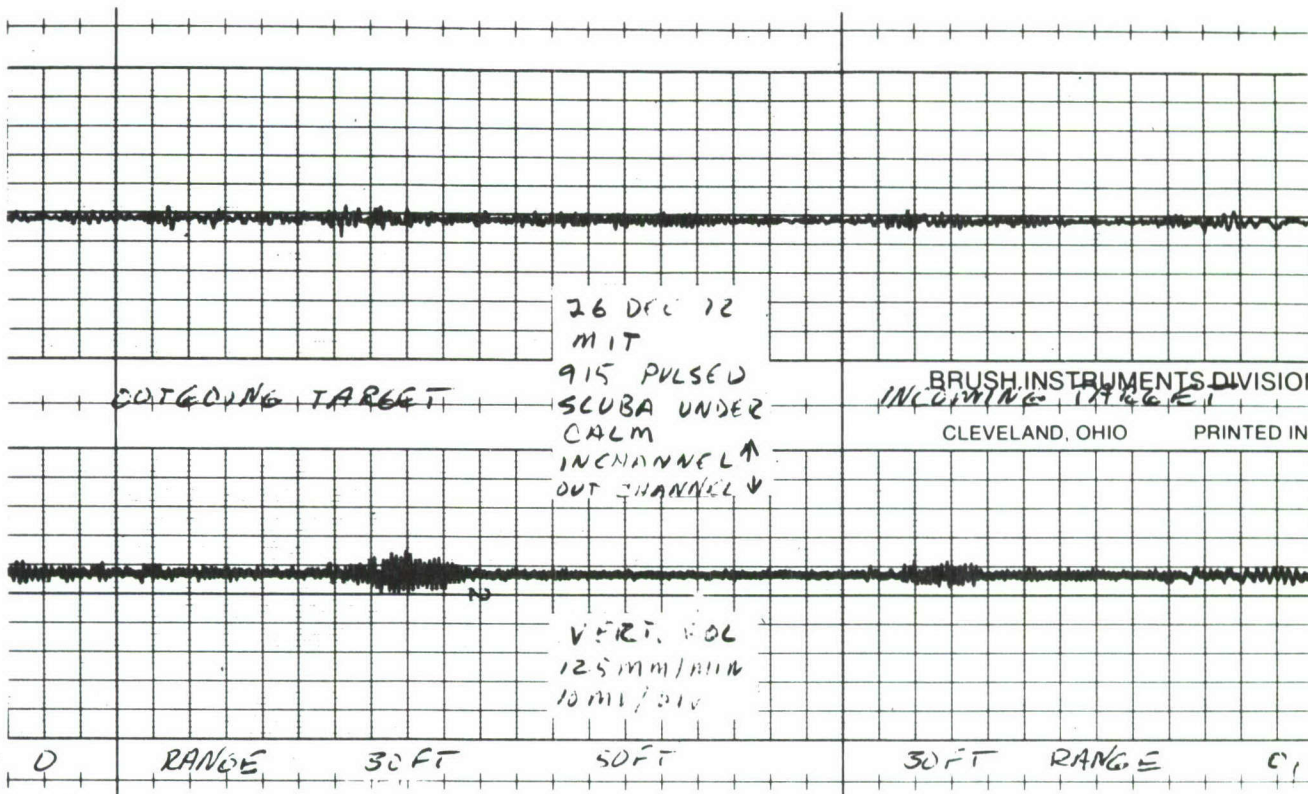


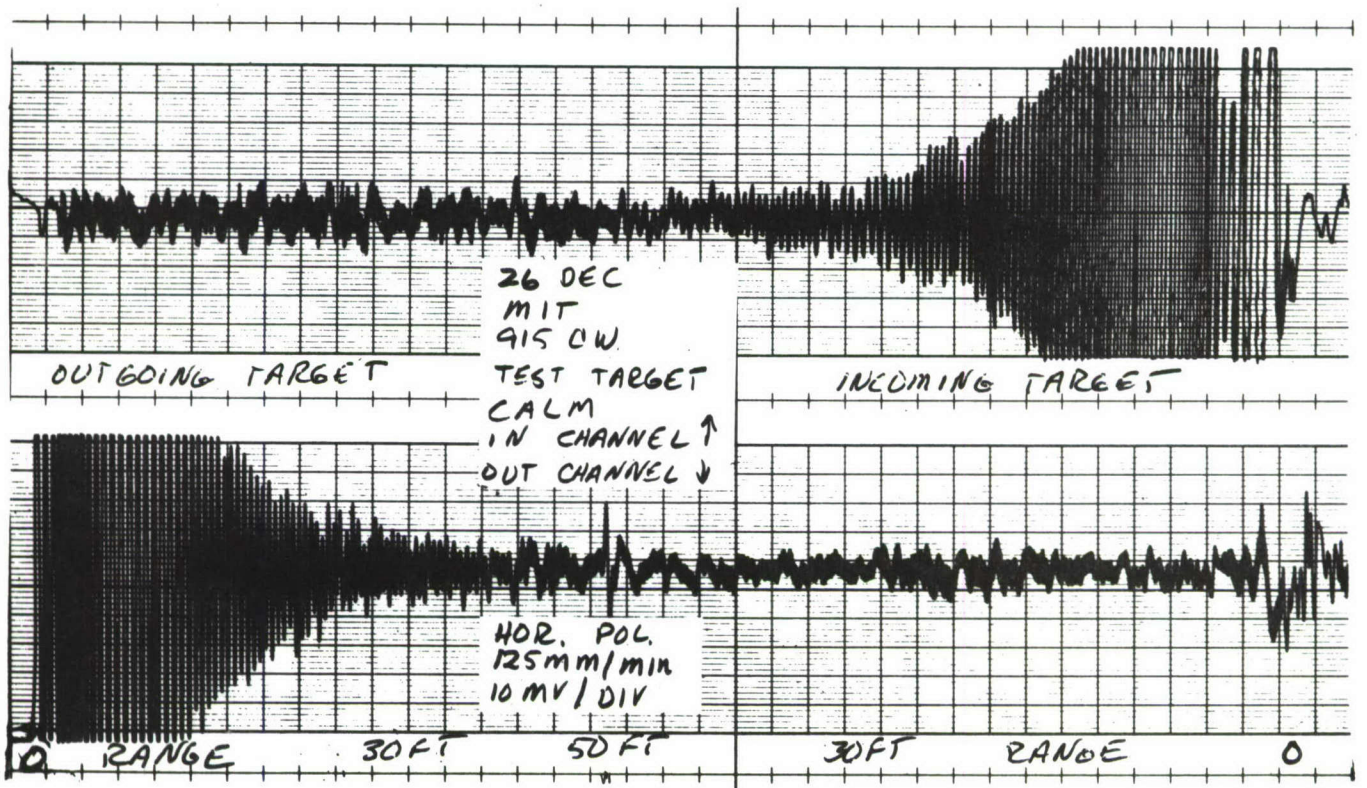
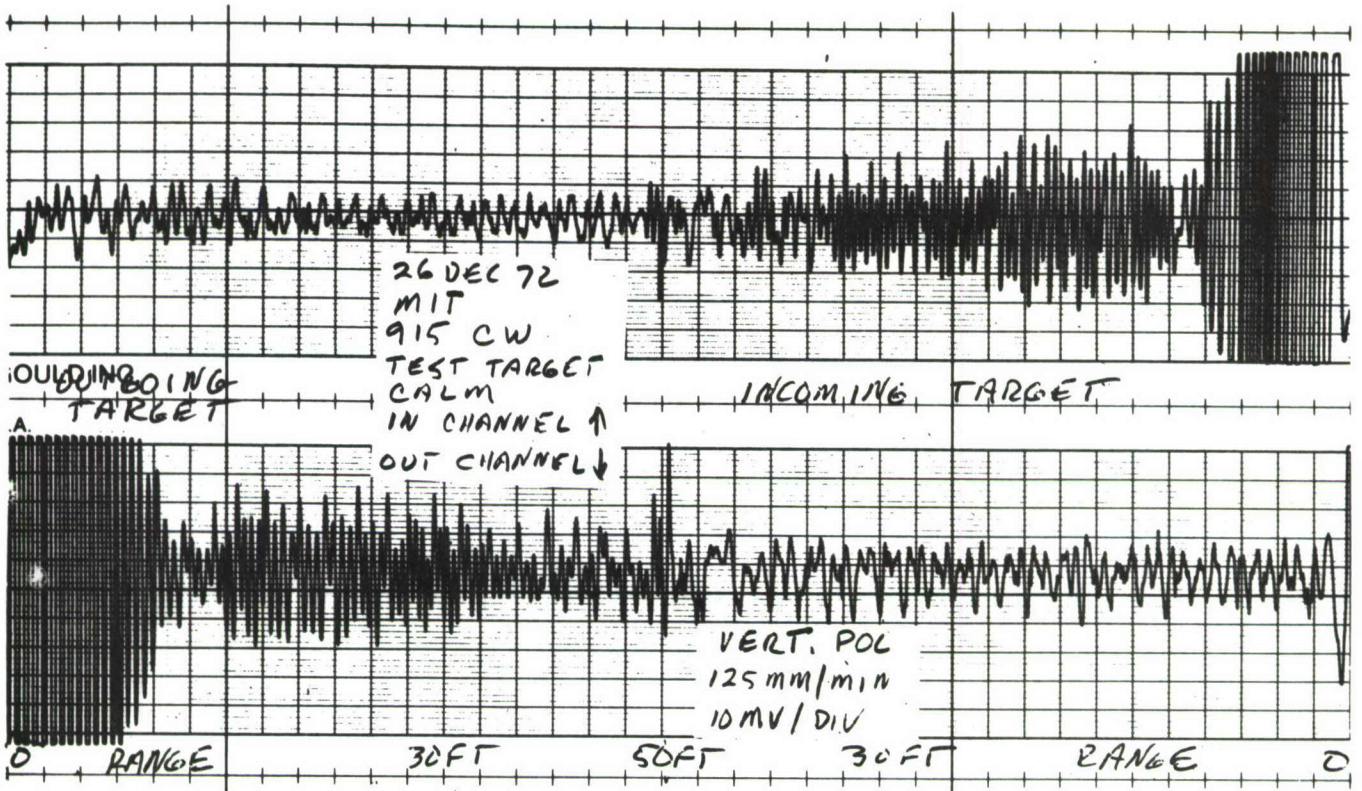


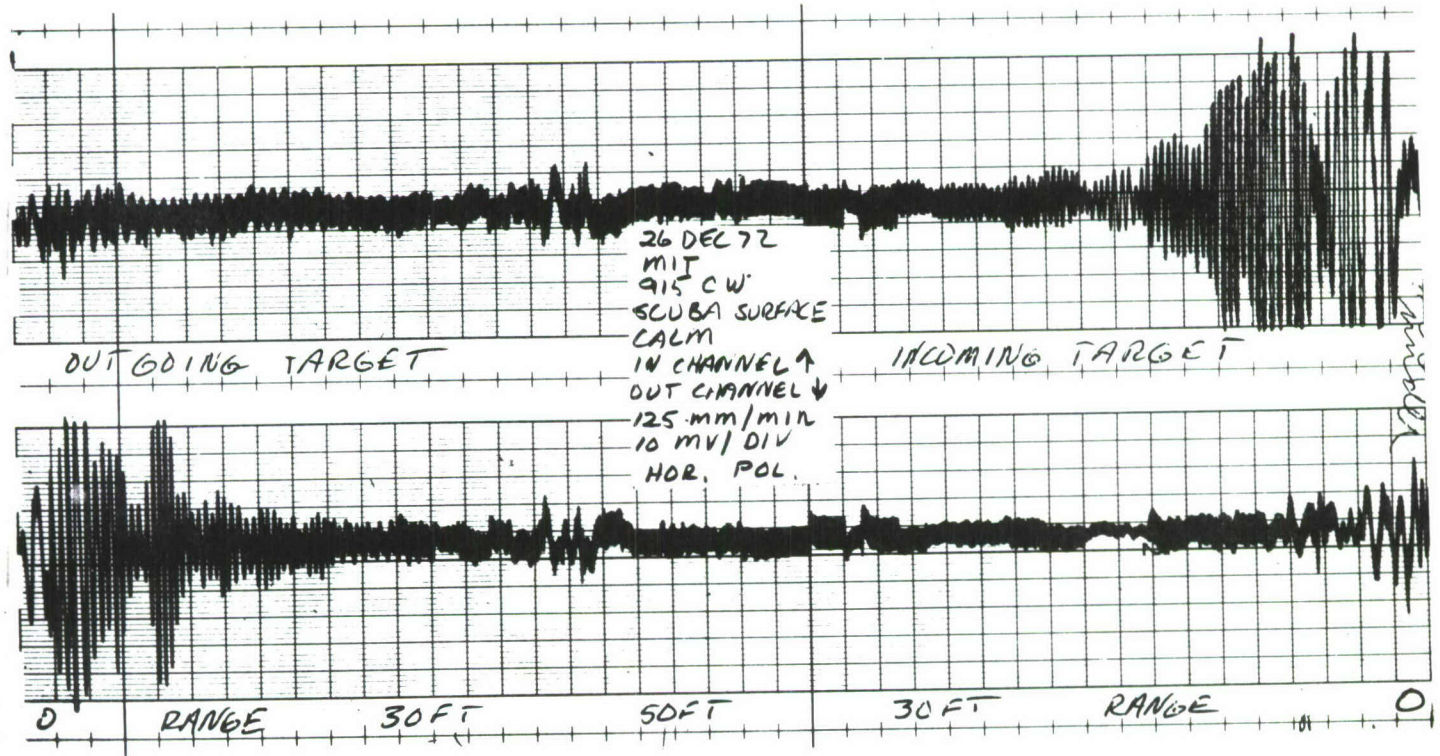
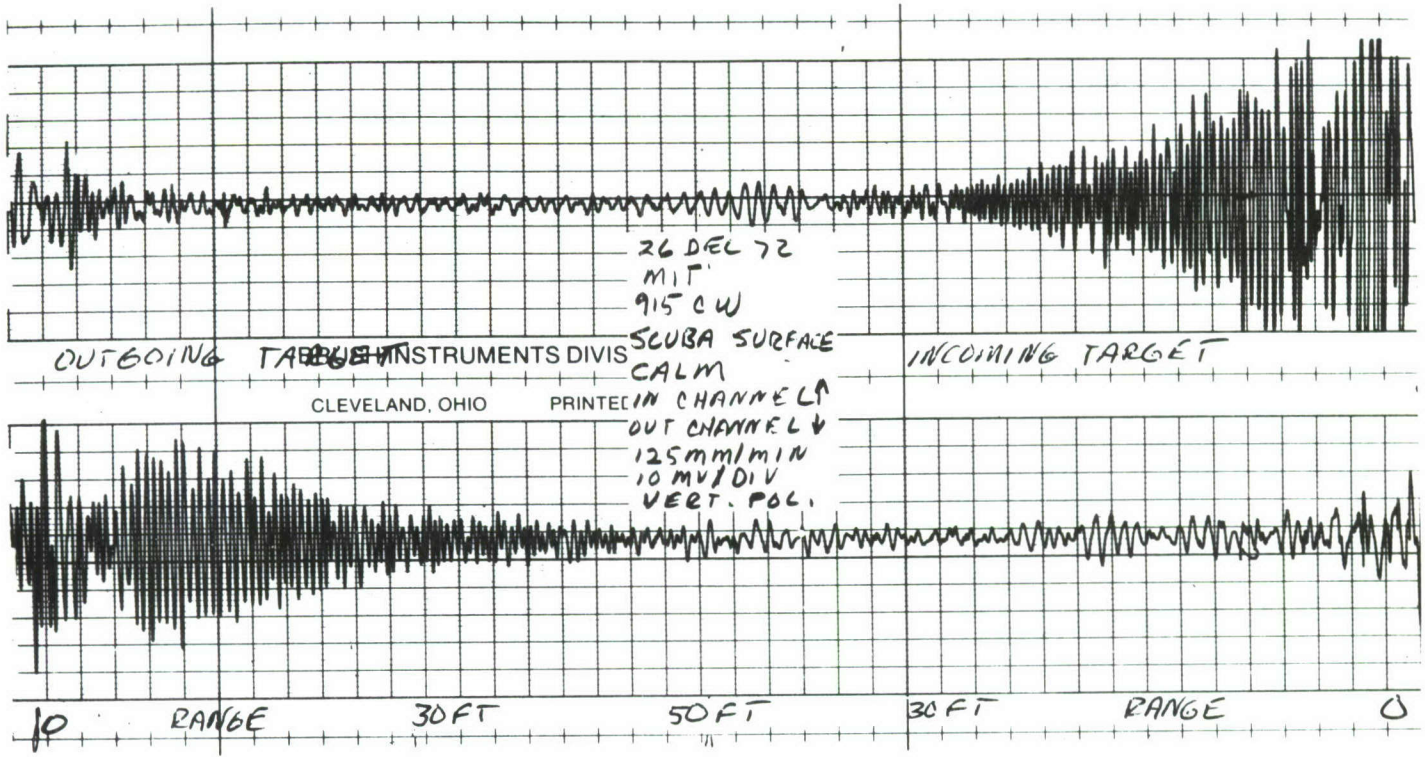


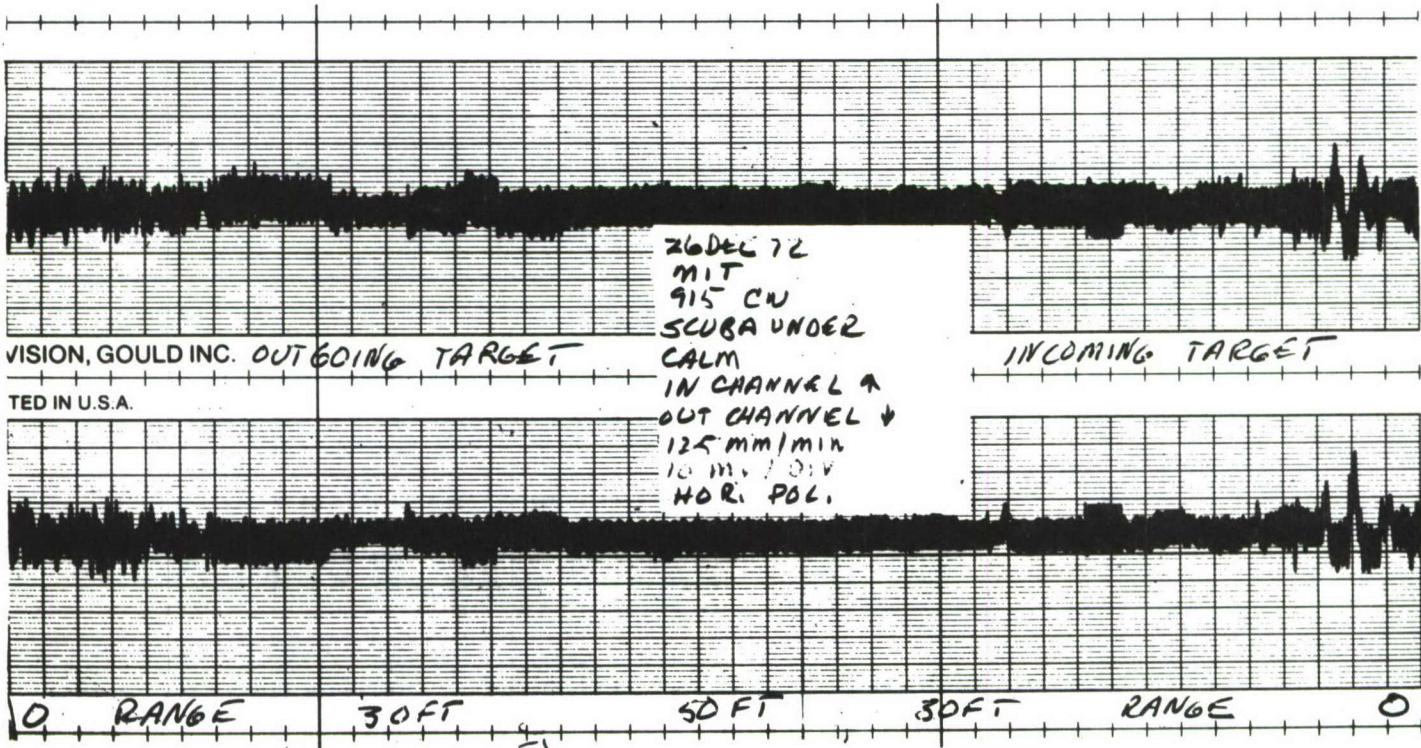
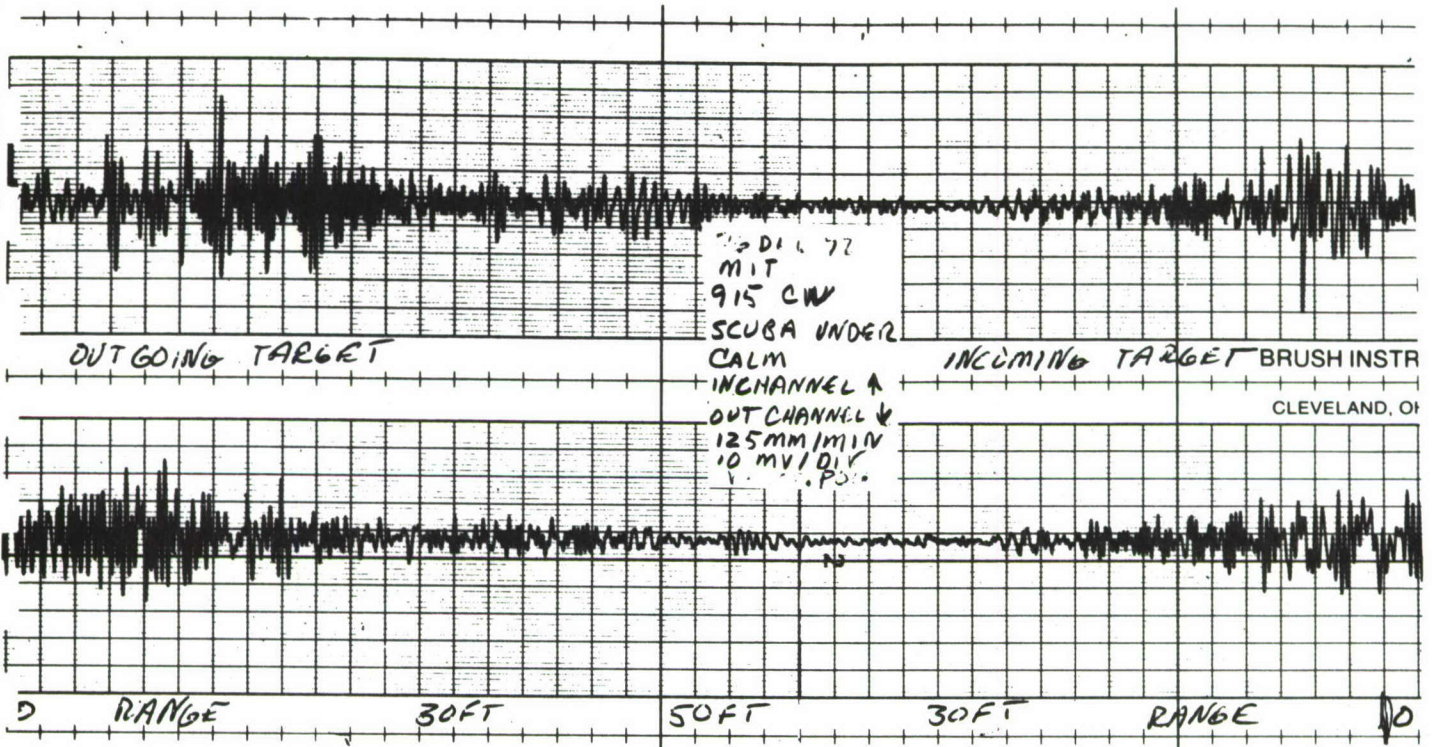












DISTRIBUTION LIST

	<u>Copies</u>
Commander US Army Materiel Command ATTN: AMCDL 5001 Eisenhower Avenue Alexandria, VA 22333	1
Commander US Army Materiel Command ATTN: AMCRD 5001 Eisenhower Avenue Alexandria, VA 22333	3
Commander US Army Materiel Command ATTN: AMCRD-P 5001 Eisenhower Avenue Alexandria, VA 22333	1
Director of Defense, Research & Engineering Department of Defense WASH DC 20301	1
Director Defense Advanced Research Projects Agency WASH DC 20301	3
HQDA (DARD-DDC) WASH DC 20310	4
HQDA (DARD-ARZ-C) WASH DC 20310	1
HQDA (DAFD-ZB) WASH DC 20310	1
HQDA (DAMO-PLW) WASH DC 20310	1
Commander US Army Training & Doctrine Command ATTN: ATCD Fort Monroe, VA 23651	1

US Marine Corps Liaison Officer 1  
Aberdeen Proving Ground, MD 21005

Director 1  
Night Vision Laboratory  
US Army Electronics Command  
ATTN: AMSEL-NV-D (Mr. Goldberg)  
Fort Belvoir, VA 22060

Commander 1  
US Air Force Special Communications Center (USAFSS)  
ATTN: SUR  
San Antonio, TX 78243

Commander 1  
US Army Armament Command  
ATTN: AMSAR-ASF  
Rock Island, IL 61201

Mr. Louis V. Surgent, Jr. 1  
800-B Tydings Lane  
Havre de Grace, MD 21078

Commander US Army Combined Arms Combat Developments Activity (PROV) Fort Leavenworth, KS 66027	1
Commander US Army Logistics Center Fort Lee, VA 23801	1
Commander US Army CDC Intelligence & Control Systems Group Fort Belvoir, VA 22060	1
TRADOC Liaison Office HQS USATECOM Aberdeen Proving Ground, MD 21005	1
Commander US Army Test and Evaluation Command Aberdeen Proving Ground, MD 21005	1
Commander US Army John F. Kennedy Center for Military Assistance Fort Bragg, NC 28307	1
Commander-In-Chief US Army Pacific ATTN: GPOP-FD APO San Francisco 96558	1
Commander Eighth US Army ATTN: EAGO-P APO San Francisco 96301	1
Commander Eighth US Army ATTN: EAGO-FD APO San Francisco 96301	1
Commander-In-Chief US Army Europe ATTN: AEAGC-ND APO New York 09403	4
Commander US Army Alaska ATTN: ARACD APO Seattle 98749	1

Commander MASSTER ATTN: Combat Service Support & Special Programs Directorate Fort Hood, TX 76544	1
Commander US MAC-T & JUSMAG-T ATTN: MACTRD APO San Francisco 96346	2
Senior Standardization Representative US Army Standardization Group, Australia c/o American Embassy APO San Francisco 96404	1
Senior Standardization Representative US Army Standardization Group, UK Box 65 FPO New York 09510	1
Senior Standardization Representative US Army Standardization Group, Canada Canadian Forces Headquarters Ottawa, Canada K1A0K2	1
Director Air University Library ATTN: AUL3T-04-572 Maxwell Air Force Base, AL 36112	1
Battelle Memorial Institute Tactical Technical Center Columbus Laboratories 505 King Avenue Columbus, OH 43201	1
Defense Documentation Center (ASTIA) Cameron Station Alexandria, VA 22314	12
Commander Aberdeen Proving Ground ATTN: STEAP-TL Aberdeen Proving Ground, MD 21005	2
Commander US Army Edgewood Arsenal ATTN: SMUEA-TS-L Aberdeen Proving Ground, MD 21010	1