

AD-782 440

HIGH-EFFICIENCY, SINGLE-FREQUENCY
LASER AND MODULATOR STUDY

R. C. Ohlmann, et al

Lockheed Missiles and Space Company,
Incorporated

Prepared for:

Office of Naval Research
Advanced Research Projects Agency

31 December 1973

DISTRIBUTED BY:

NTIS

National Technical Information Service
U. S. DEPARTMENT OF COMMERCE
5285 Port Royal Road, Springfield Va. 22151

AD782440



STATEMENT A
Approved for public release;
Distribution Unlimited

D D C
RECORDED
JUL 18 1974
RECEIVED
B

Reproduced by
NATIONAL TECHNICAL
INFORMATION SERVICE
U S Department of Commerce
Springfield VA 22151

**HIGH-EFFICIENCY, SINGLE-
FREQUENCY LASER AND
MODULATOR STUDY**

11th Quarterly Technical Report

N-JY-71-22 31 December 1973

**R. C. Ohlmann, K. K. Chow, J. J. Younger, W. B. Leonard,
D. G. Peterson, and J. Kannelaud**

**ARPA Order No. 306
Expiration Date: 15 June 1974
Amount: \$399,684**

**Contract No. N00014-71-C-0049
Program Code 421
Effective Date of Contract: 1 September 1970**

**Scientific Officer: Director, Physics Programs
Physical Sciences Division
Office of Naval Research, Arlington, Va. 22217**

Principal Investigator: R. C. Ohlmann (415) 493-4411, Ext. 45275

**Sponsored by
Advanced Research Projects Agency**

**The views and conclusions contained in this document are those
of the authors and should not be interpreted as necessarily repre-
senting the official policies, either expressed or implied, of the
Advanced Research Projects Agency of the U. S. Government.**

**Lockheed Palo Alto Research Laboratory
LOCKHEED MISSILES & SPACE COMPANY, INC.
A Subsidiary of Lockheed Aircraft Corporation
Palo Alto, California 94304**

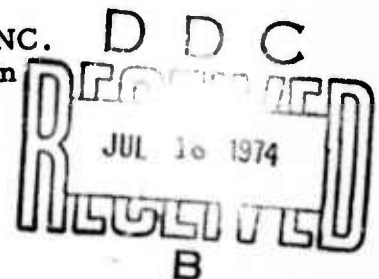

**Reproduced by
NATIONAL TECHNICAL
INFORMATION SERVICE
U. S. Department of Commerce
Springfield VA 22151**

**DISTRIBUTION STATEMENT A
Approved for public release;
Distribution Unlimited**

Section 1
INTRODUCTION

The work described in this report is the final year's effort of a three-year program to study wide bandwidth laser communications at 1.06- μ m wavelength. Earlier efforts of this program (during the first two years) were directed to studying the means to produce a high-efficiency, single-frequency neodymium doped yttrium aluminum garnet (Nd:YAG) laser operating at 1.06 μ m, and to produce high-efficiency, octave-bandwidth, microwave light modulators for this wavelength (Refs. 1 and 2). In addition, a study was also made of laser communication configurations that were suitable for very high data rates. The overall objective of this year's program, then, is to apply the results of these earlier studies to assemble a laboratory communication system that uses the entire modulation bandwidth available. In particular, the final result of this program is to be a laboratory demonstration of a laser-communication system having a bandwidth of 2 GHz.

1.1 OBJECTIVES

The detailed objectives of this study program are as follows:

- (1) Design a laboratory communication system, using 1.06- μ m radiation from a Nd:YAG laser and having a system bandwidth of 2 to 4 GHz.

- (2) Assess the state-of-the-art of high-frequency photodetectors, with emphasis on a cross-field photomultiplier tube (PMT), that offer good frequency and spectral response and are suitable as the receiver elements of this communication demonstration.
- (3) Define and design any necessary microwave, digital-modulation, and frequency-modulation subsystems for the communication system.
- (4) Assemble and operate the various subsystems.
- (5) Demonstrate and evaluate the system performance in a laboratory environment.

1.2 LASER COMMUNICATION SYSTEMS

Work performed during this quarter has led to the successful achievement of objective (2) and partial achievement of objectives (3), (4), and (5). The transmission of 1 - GHz analog and 1-Gbit/sec digital data over the laser link has been accomplished in the laboratory. However, improvement of signal-to-noise ratios of analog signals as well as reduction of intermodulation problems between the analog signals are most desirable. Work is in progress to achieve these goals. It is estimated that a full-fledge demonstration, with improved signal-to-noise ratios, will be made by March 31, 1974.

1.3 PUBLICATIONS

A paper, entitled "Recent Advances in Ultra wideband Bandpass Optical Beam Modulators," has been presented at the 1973 International Electron

Devices Meeting in Washington, D.C., (Dec. 3-5, 1973). Another paper, entitled "A 2-Gbit/sec Laboratory Laser Communication System" is under preparation for submission to the Sixth DoD Conference on Laser Technology, Colorado Springs, Colorado, in March 1974.

Section 2

SYSTEM DESIGN

In the Third Semiannual Technical Report (Ref. 3), detailed considerations and descriptions of the system design have been given. Therefore, in this report, only a summary will be given below, reference is made to the Third Semiannual Technical Report for further details.

Block diagrams showing various transmitter and receiver subsystems and the quadriphase shift-keying (QPSK) modulation format used in the 2 Gbit/sec laboratory communication system demonstration are given in Figs. 2-1 and 2-2. The system can handle either a two-gigabit-per-second rate data stream by modulating it onto two microwave subcarriers using the QPSK modulation format as shown in these figures, or analog signals having a bandwidth of one gigahertz together with one gigabit per second digital data. For the transmission of this combined analog/digital data, one of the QPSK subsystems is substituted by an analog signal subsystem as shown in Fig. 2-3. Detailed block diagrams showing the operation of the analog FM subsystem are given in Figs. 2-4 and 2-5. To fill the available analog channel bandwidth, several local TV channels and a narrowband FM music channel at 400 MHz are used. This is shown in Figure 2-4.

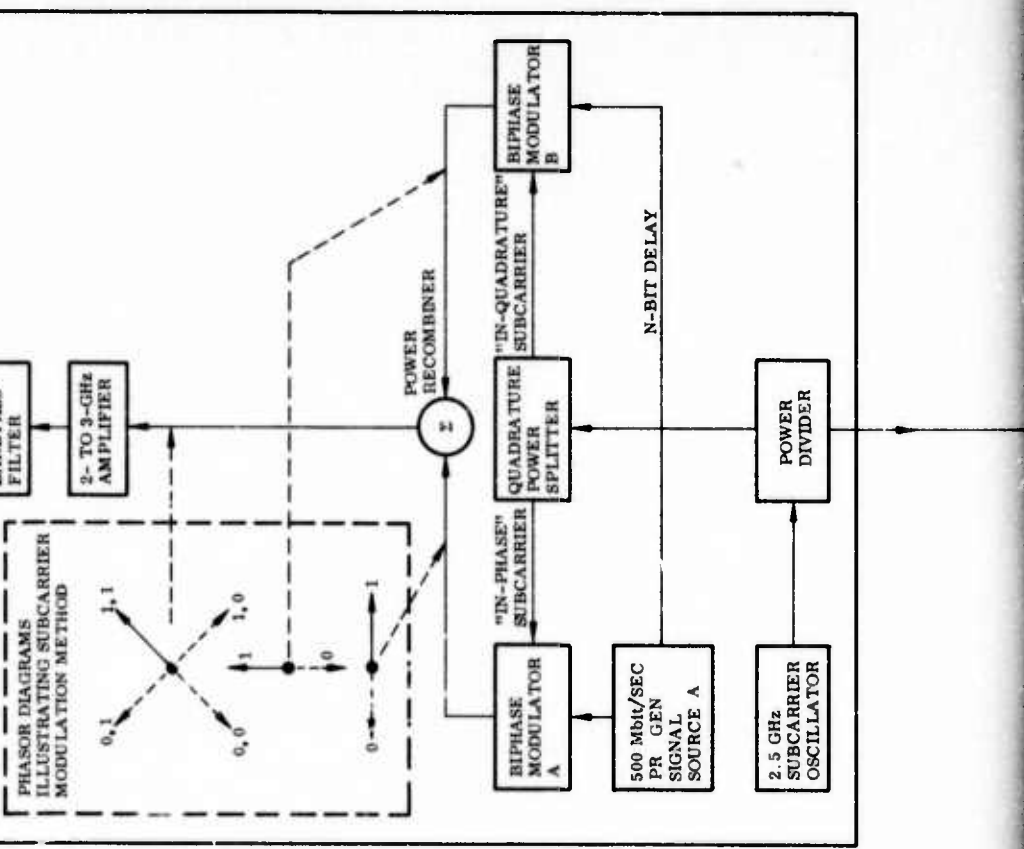
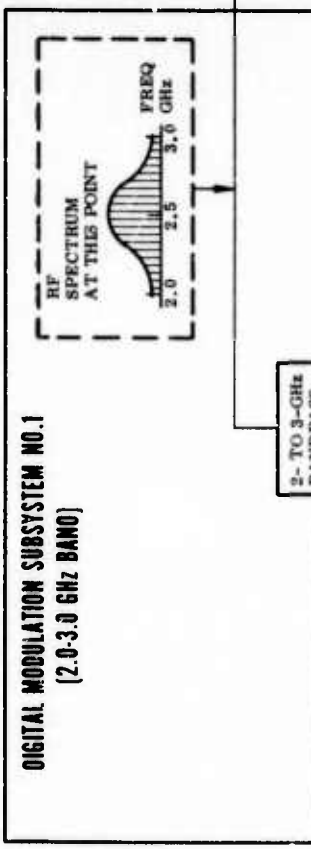
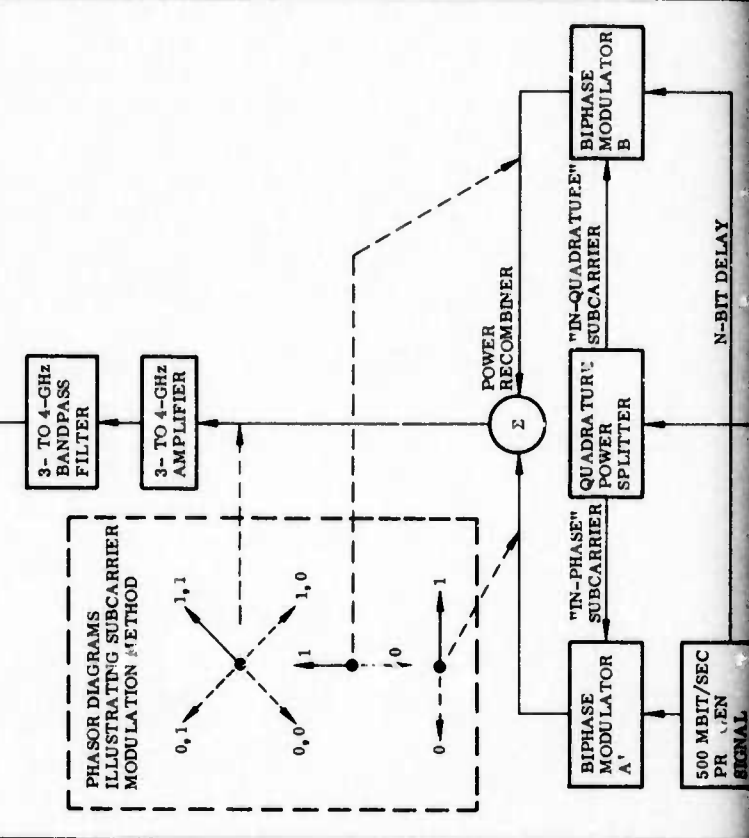
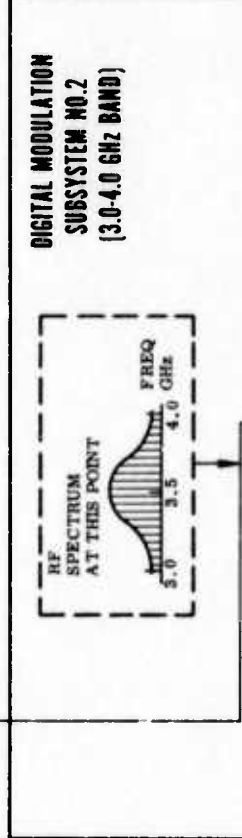
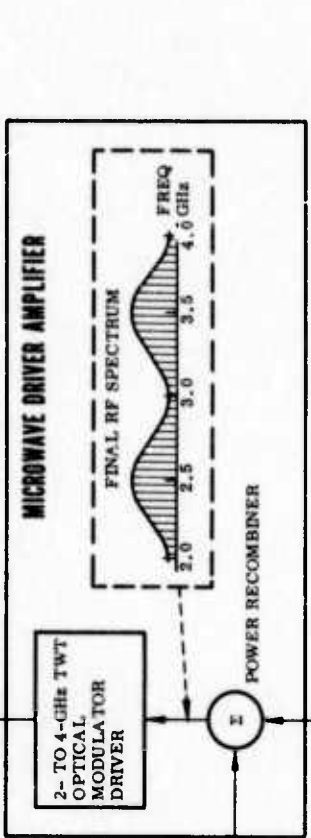
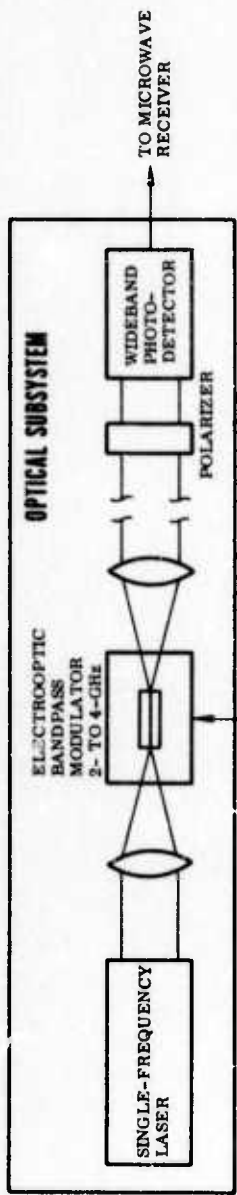

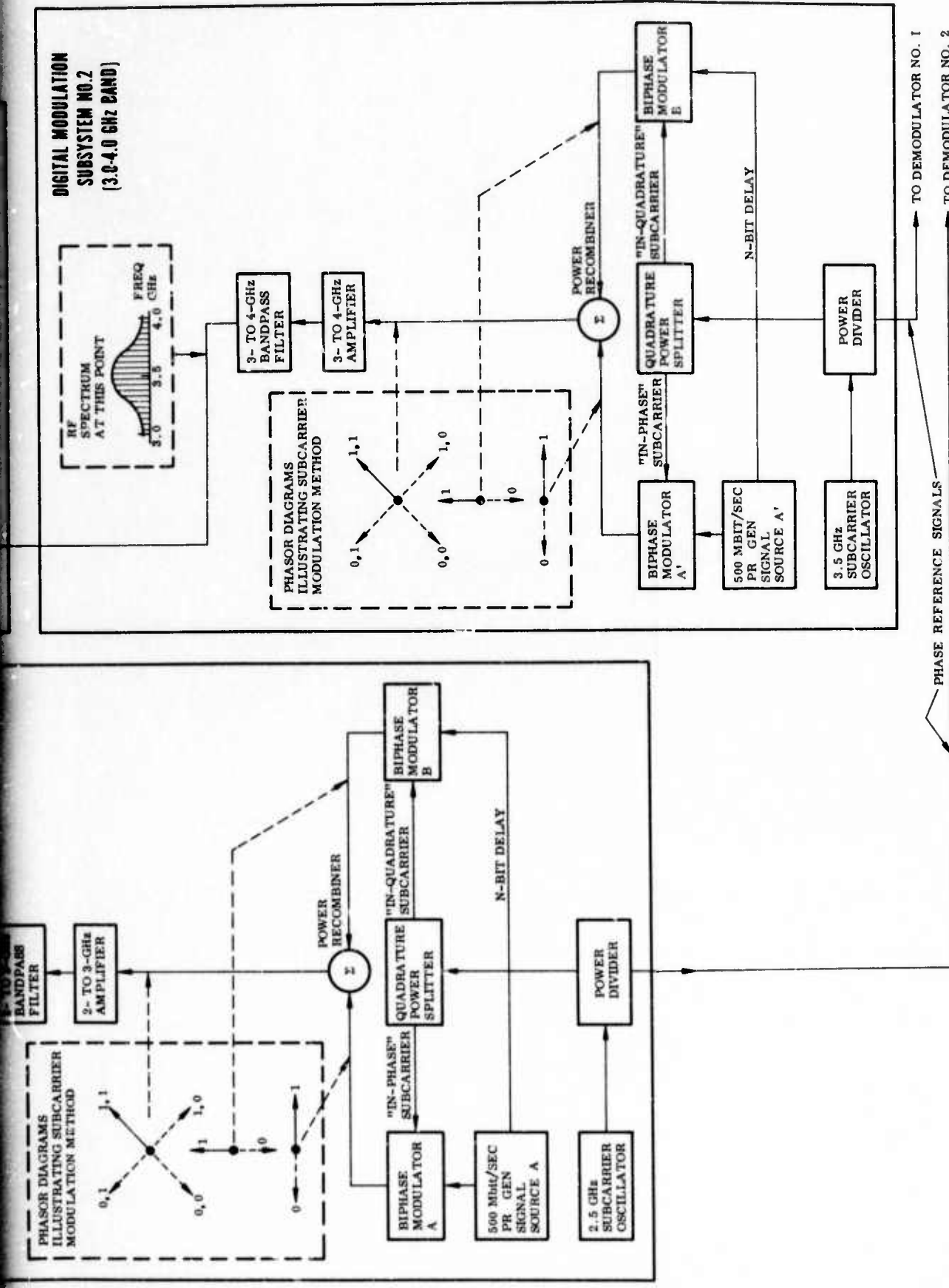
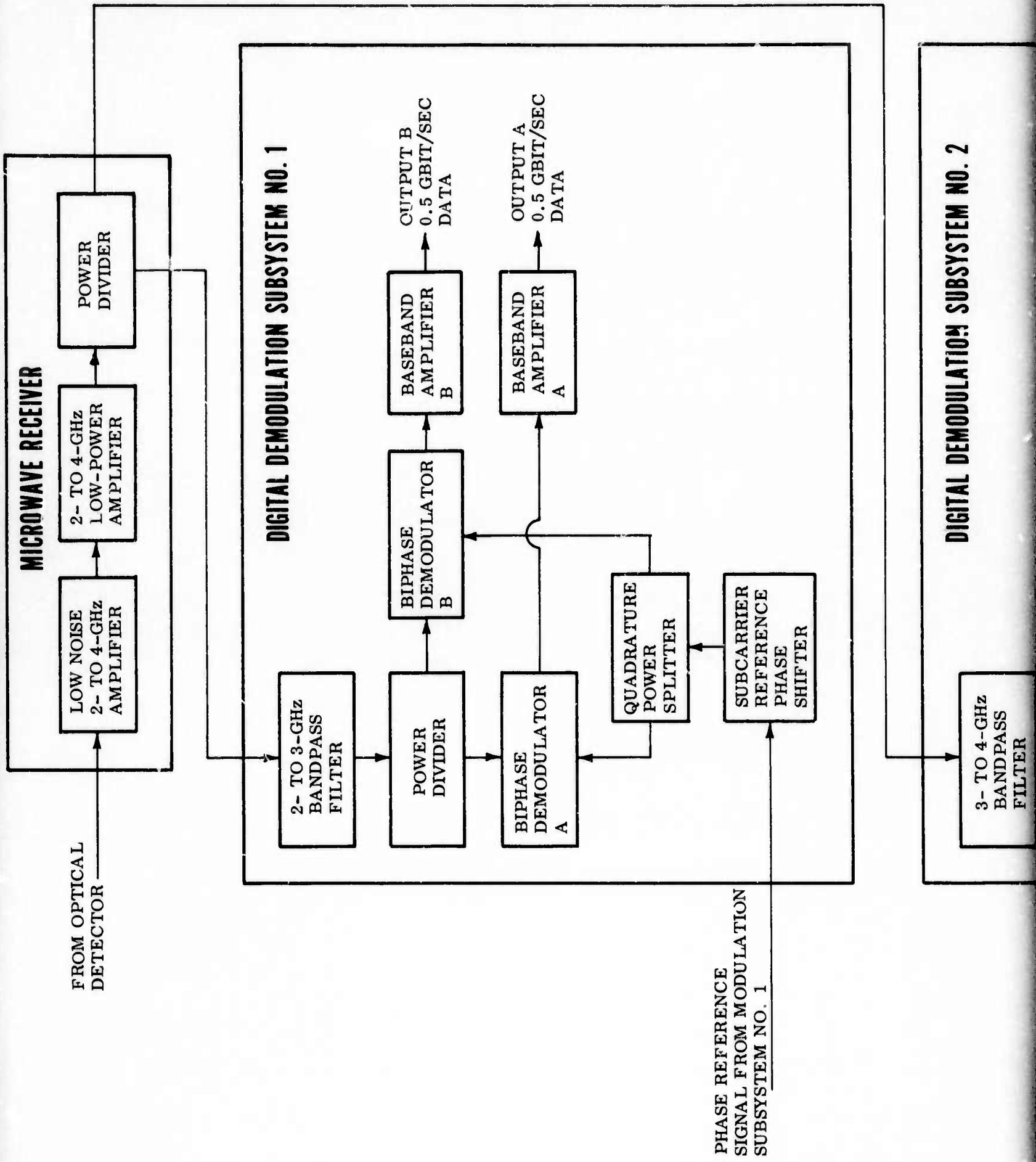

Fig. 2-1 2-Gbit/sec Laboratory Laser Communication System: Optical Subsystem and Transmitter Electronics



MICROWAVE RECEIVER

DIGITAL DEMODULATION SUBSYSTEM NO. 1

DIGITAL DEMODULATION SUBSYSTEM NO. 2

FROM OPTICAL DETECTOR

PHASE REFERENCE SIGNAL FROM MODULATION SUBSYSTEM NO. 1

OUTPUT B 0.5 GBIT/SEC DATA

OUTPUT A 0.5 GBIT/SEC DATA

3- TO 4-GHz BANDPASS FILTER

LOW NOISE 2- TO 4-GHz AMPLIFIER

POWER DIVIDER

2- TO 4-GHz LOW-POWER AMPLIFIER

2- TO 3-GHz BANDPASS FILTER

POWER DIVIDER

BIPHASE DEMODULATOR A

BIPHASE DEMODULATOR B

BASEBAND AMPLIFIER B

BASEBAND AMPLIFIER A

QUADRATURE POWER SPLITTER

SUBCARRIER REFERENCE PHASE SHIFTER

SIGNAL FROM MODULATION
SUBSYSTEM NO. 1

SUBCARRIER
REFERENCE
PHASE
SHIFTER

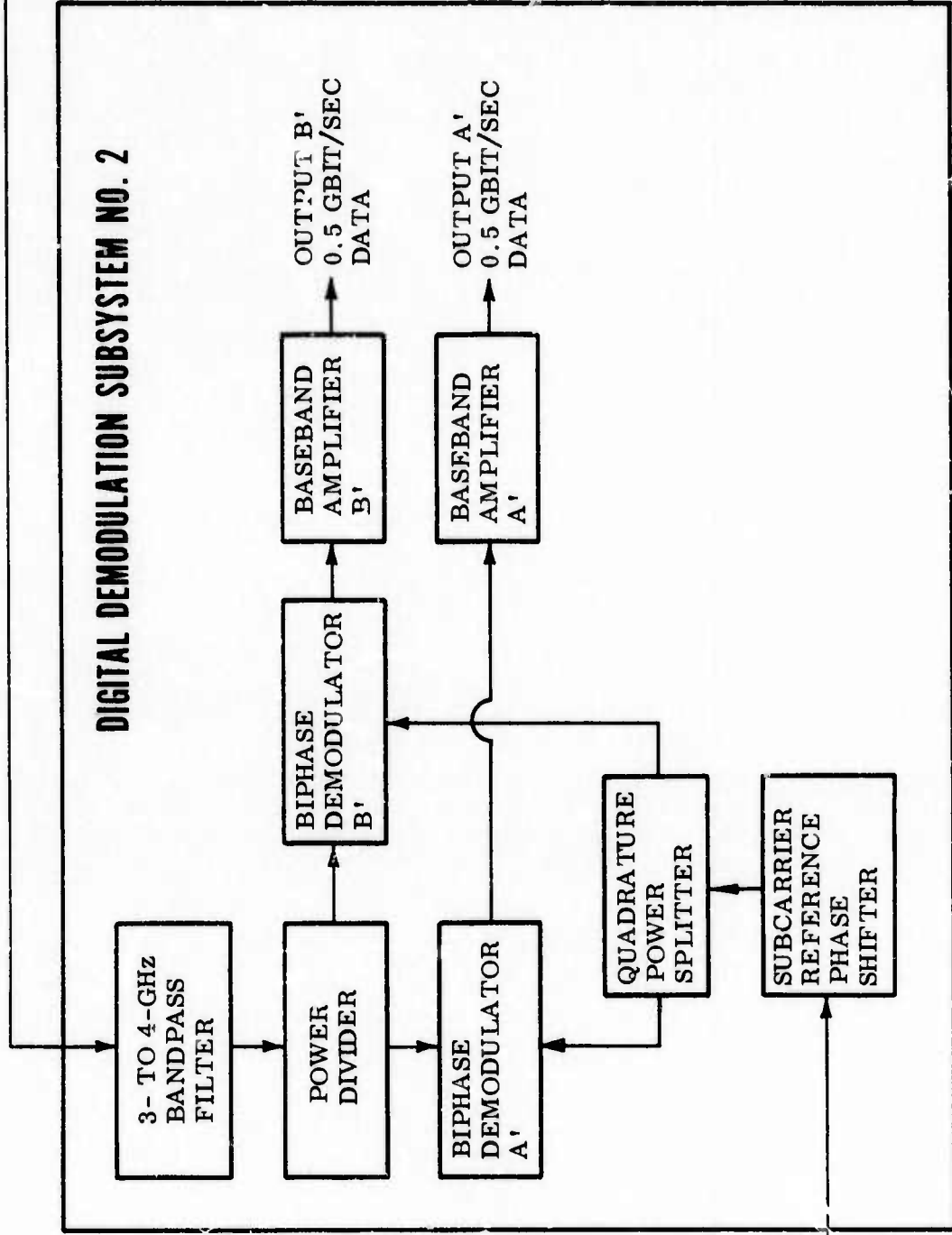

PHASE REFERENCE
SIGNAL FROM MODULATION
SUBSYSTEM NO. 2

Fig. 2-2 2-Gbits/sec Laboratory Laser Communication System: Receiver Electronics

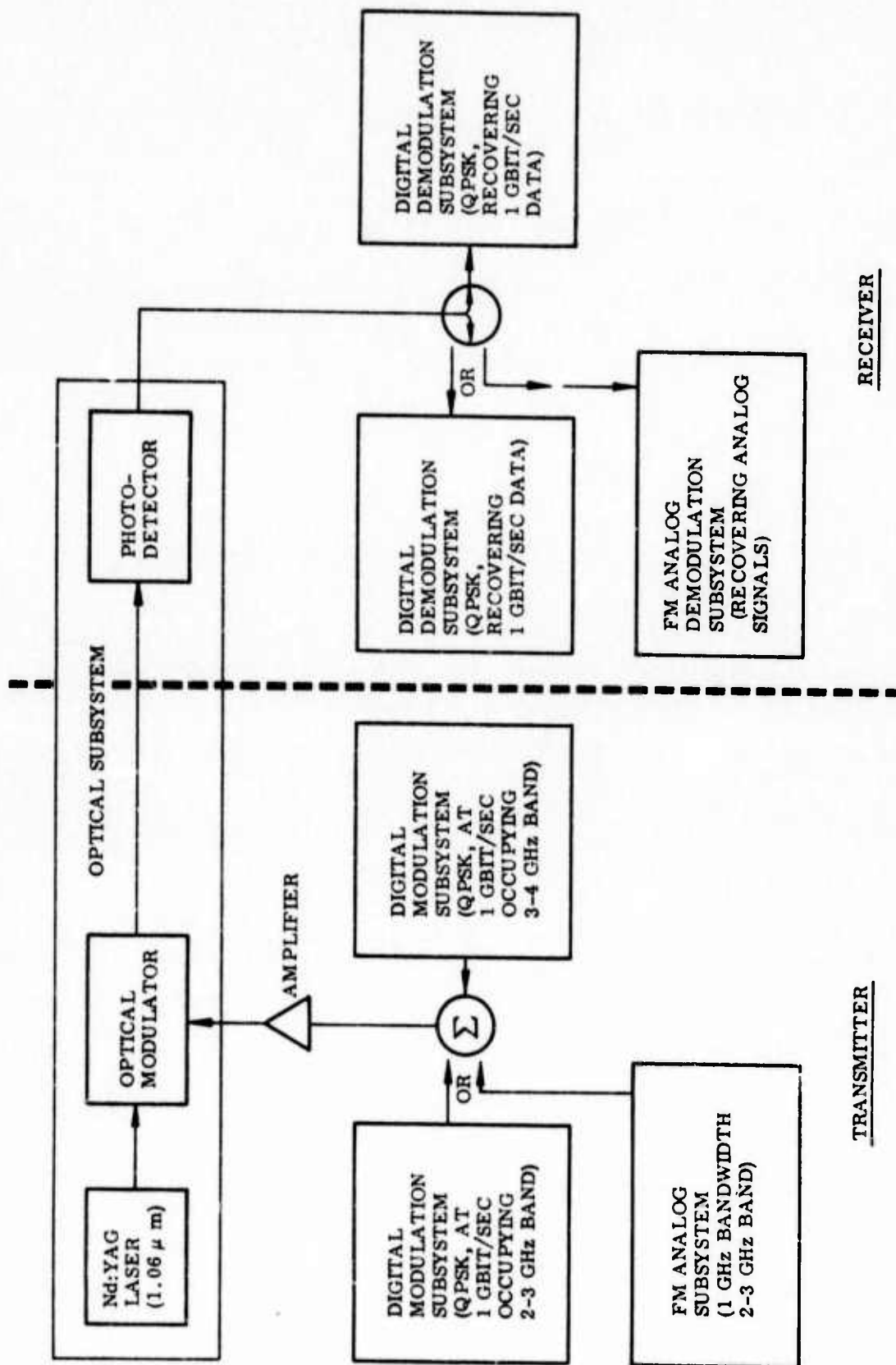

Fig. 2-3 Block Diagram Showing Various Subsystems and Modulation Formats Used in the Laboratory Communication System Demonstration

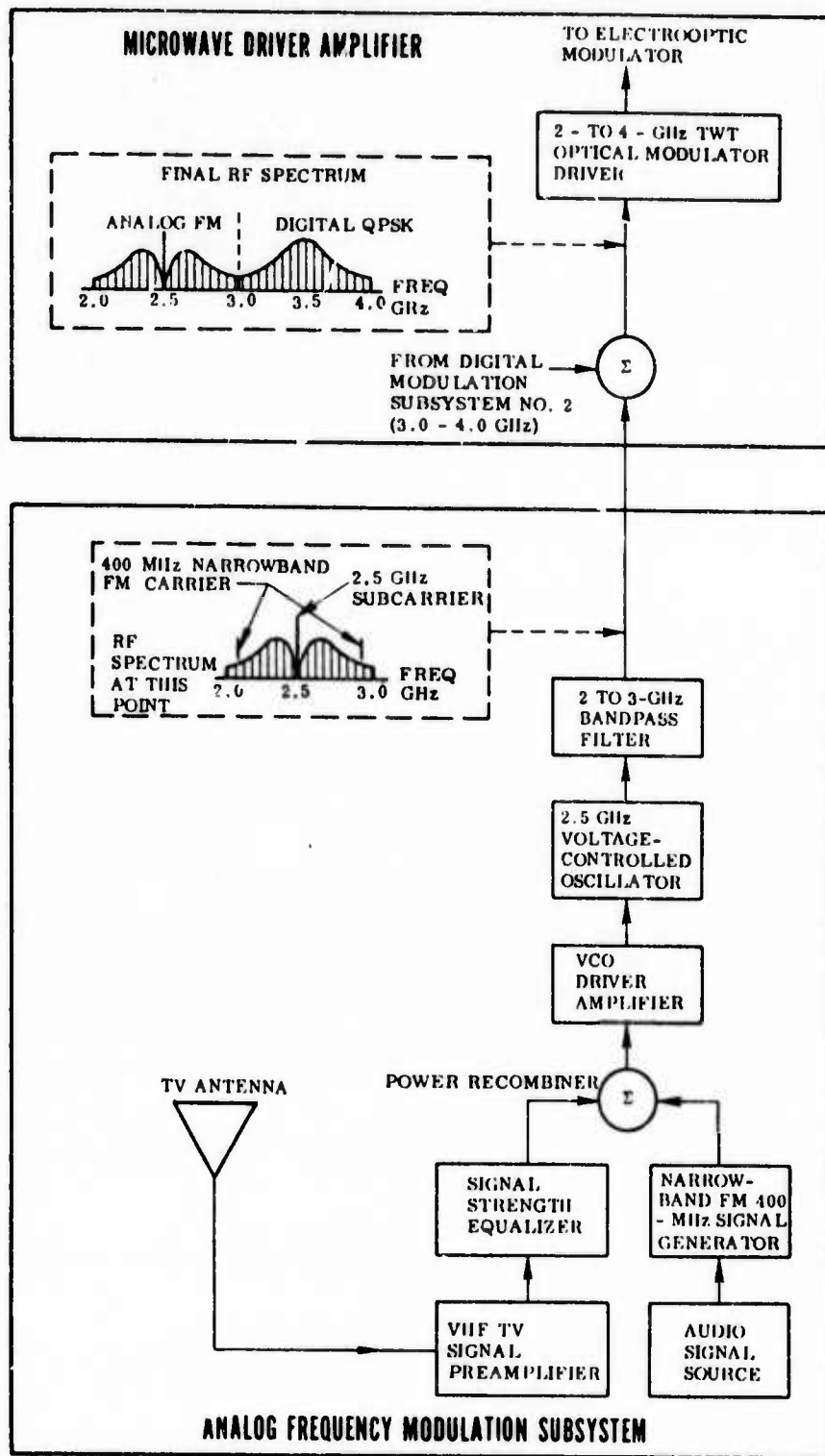

Fig. 2-4 Diagram Illustration: the FM Subsystem and the Combination of FM Analog and QPSK Digital Signals

FROM PHOTODETECTOR

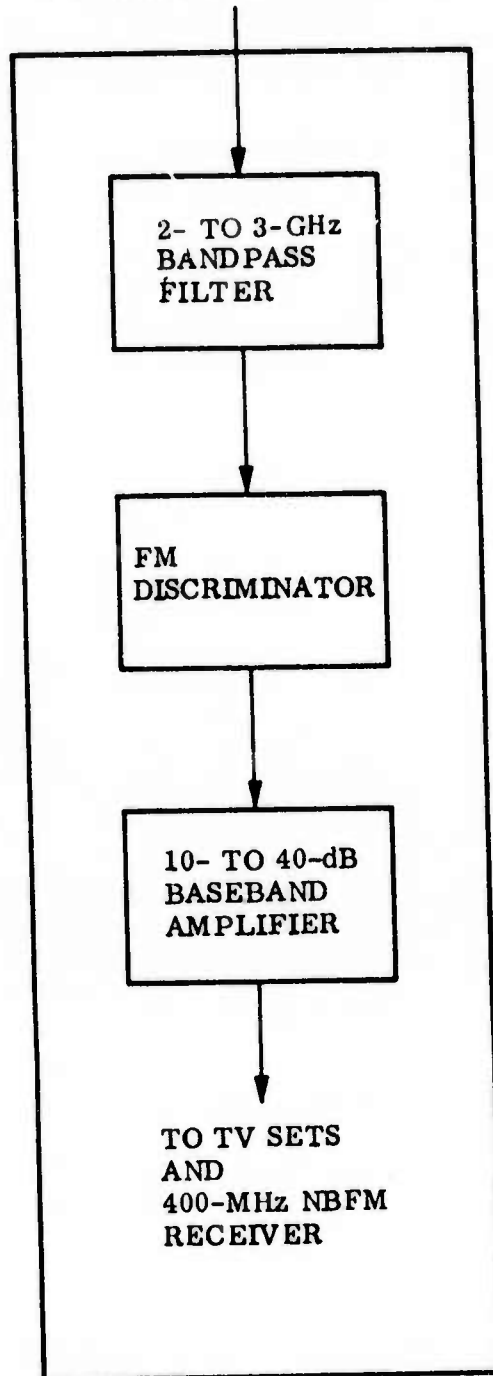

Fig. 2-5 The FM Demodulation System

The bulk of the digital data transmission work was done during the first six months, only a small amount of work in that direction was done during this quarter. The transmission of the combined one gigahertz FM analog and one-gigabit QPSK digital data was initiated during the first six months. Some difficulties were encountered because the subcarrier frequency chosen for the analog portion (3.5 gigahertz) appeared too high (Ref. 3). As a result, the 2.5 gigahertz subcarrier was used for the transmission of FM analog signals as shown in Figs. 2-3, 2-4 and 2-5. This necessitated a certain amount of change in components and system design. Fortunately, it is not a major task and, by the middle of this quarter, the experimental demonstration has begun to take shape.

Section 3

CRITICAL COMPONENTS

Most of the critical components required for the system demonstration have been discussed in some detail in the Third Semiannual Technical Report (Ref. 3). Therefore, we shall only present the changes that have been made during this quarter. For additional information, reference is made to the Third Semiannual Report.

3.1 THE OPTICAL MODULATOR

The performance of the optical modulator was much improved during the first six months. Uniform frequency response was obtained in the 2 to 4 gigahertz band as indicated by optical sideband measurements shown in Fig. 3-1.

Actual measurement of modulation index near the peak response showed that 80% modulation index for 0.5145 μm was obtainable at 8.3 W of rf drive power.

This modulator was used in the initial tests for the 2-Gbit/sec data transmission and performed well, as reported in the Semiannual Report (Ref. 3). Unfortunately, in the initial experiments for the 1-GHz analog and the 1 Gbit/sec digital transmission, the electro-optical crystal inside the modulator was fractured. A new modulator crystal was substituted into the modulator. Because of the schedule, it was not possible to make detailed tuning and matching to duplicate the results obtained earlier. Modulation index as a function of frequency,

obtained for the final version of the modulator, is as shown in Fig. 3-2. Obviously, the performance was not as good as that obtained earlier, but this proved adequate for the demonstration of the 1GHz analog and the 1-Gbit/sec digital data transmission. Laboratory measurements indicate that approximately 35% modulation index is repeatedly obtainable at 2.0 W of drive at 3 GHz.

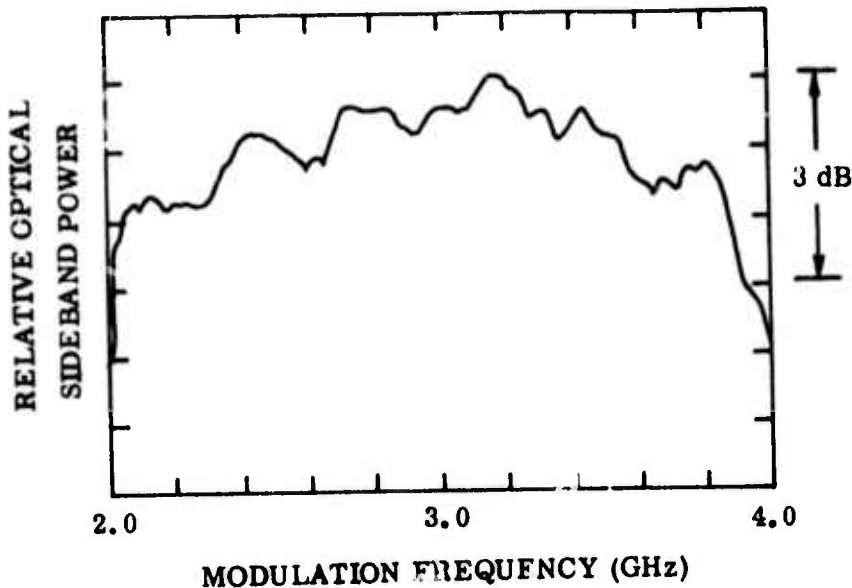

Fig. 3-1

Relative Optical Sideband Power as a Function of Modulation Frequency at Low Drive Power Levels for the First Version of the Optical Modulator.

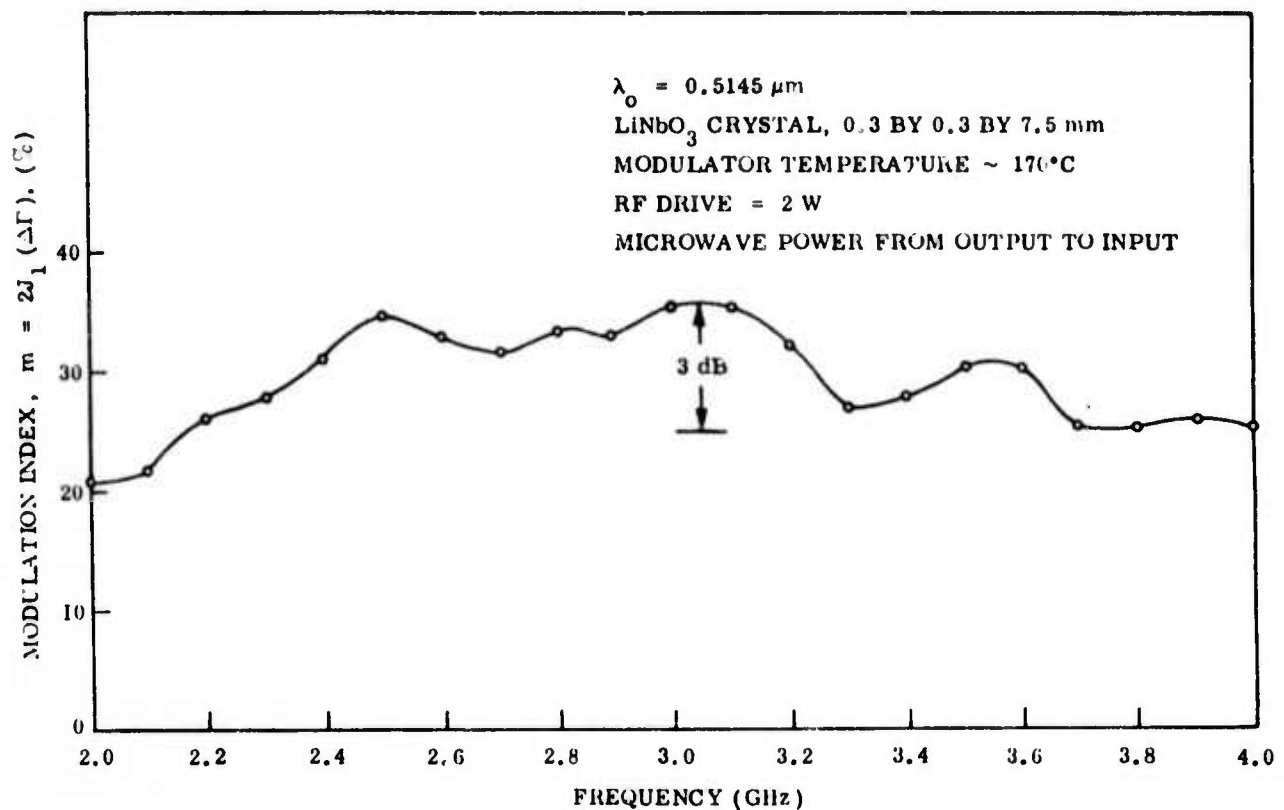

Fig. 3-2 Modulation Index as a Function of Frequency at 2-W Drive Power Level for the Final Version of the Modulator

3.2 PHOTODETECTORS

Since the cross-field photomultiplier tube (CFPMT) specially ordered from Varian Associates did not fulfill our requirements, much effort was expended in the selection of a suitable photodetector. Solid-state photodiodes were investigated; these included silicon PIN diodes, germanium PIN diodes, as well as a silicon avalanche diode. All these diodes have rather low frequency response in the 3- to 4-GHz range; however, both silicon and germanium PIN diodes appeared useful. Test results are briefly described as follows.

In these tests, the frequency response of the optical modulator was first determined by measuring the optical sideband power as a function of modulation frequency in a Fabry-Perot scanning interferometer. The modulated laser beam is then detected by the photodetector under test. The output of the photodetector is fed into a microwave spectrum analyzer, swept at a very low frequency. The frequency response as displayed on the cathode-ray tube of the spectrum analyzer then gives the combined effects due to the optical modulator and the photodetector. That is, the display gives the apparent received microwave power as a function of frequency. Since the received power is proportional to the square of the modulation index, the apparent modulation index as seen by the spectrum analyzer can be obtained by taking the square root of the power spectrum. When this apparent modulation index is divided by the known modulation index for the optical modulator as measured previously, frequency response of the photodetector is obtained. For convenience, these tests were initially made at $0.5145 \mu\text{m}$. Those having favorable frequency response were later tested at $1.06 \mu\text{m}$.

Figure 3-3 is the frequency response curve for a commercial silicon avalanche diode (TI Model XL 55). It is seen that beyond 3.0 GHz, the response was very poor. Since avalanche noise was also very high, the diode was not useful even at the visible wavelength. There is a germanium avalanche diode (TI XL 57) available for $1.06 \mu\text{m}$ wavelength. Its specifications on frequency response and noise characteristic are much worse than those of TI XL 55. Therefore, the germanium avalanche diode was not seriously considered.

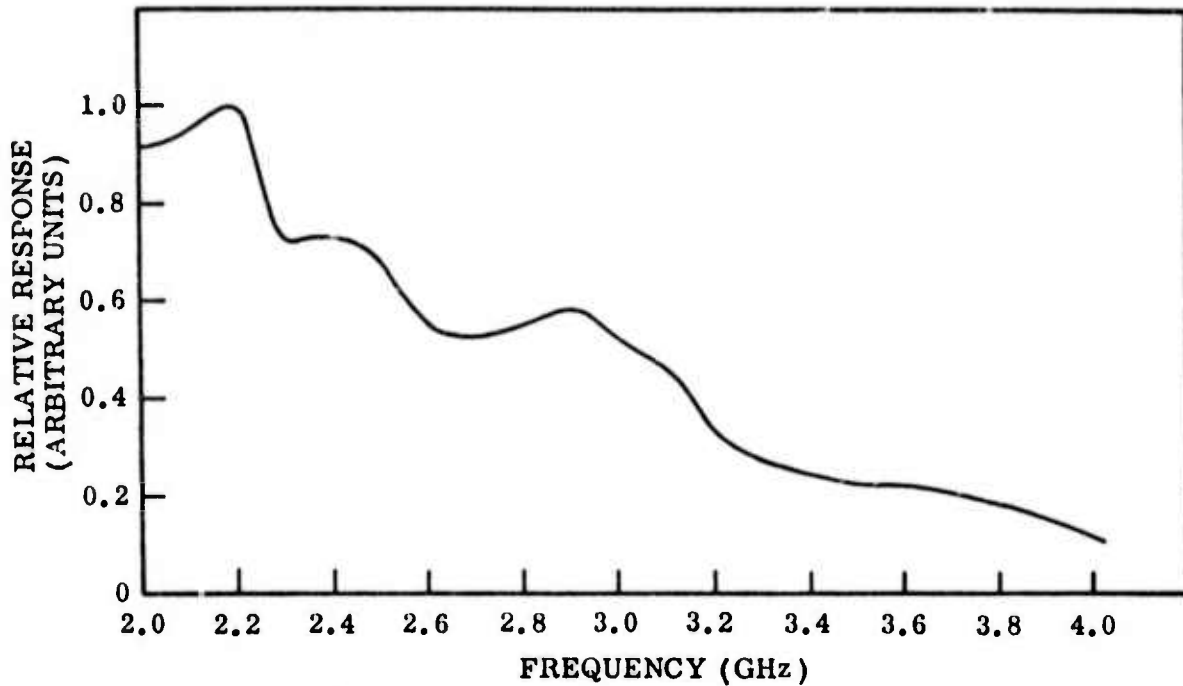

Fig. 3-3 Relative Frequency Response of the TI Silicon Avalanche Diode-
Test Performed at 0.5145 μm

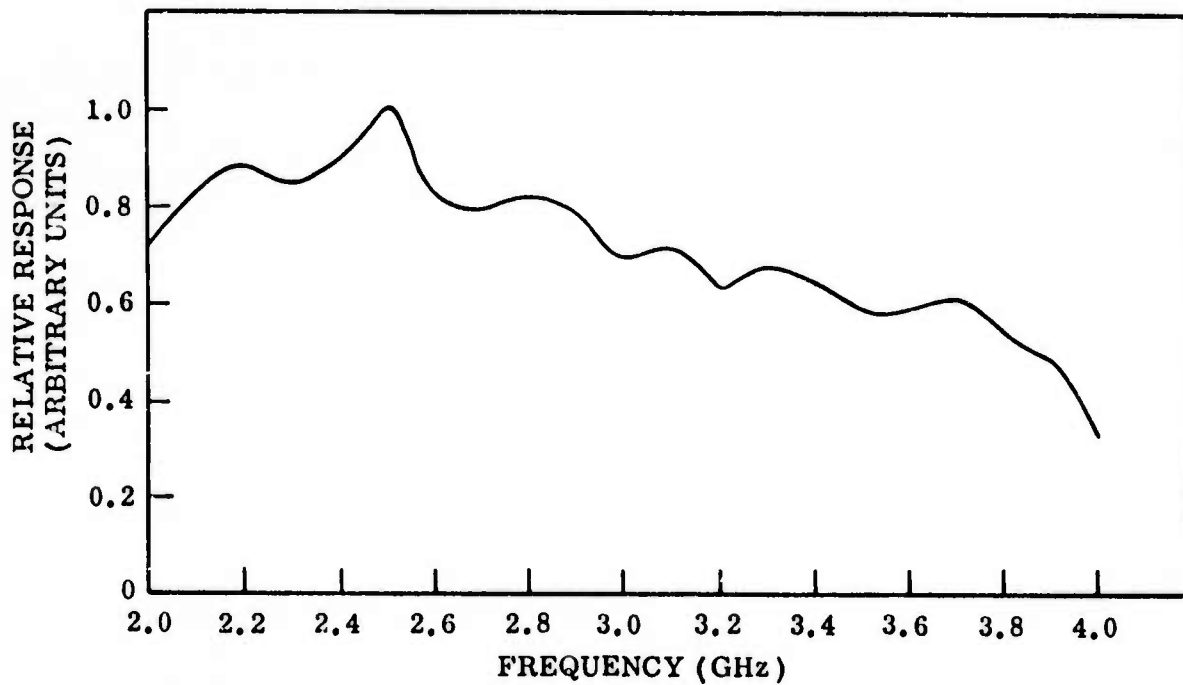

Fig. 3-4 Relative Frequency Response of the Philco Silicon PIN Diode-
Test Performed at 0.5145 μm

Figure 3-4 is the response curve for a silicon PIN diode (Philco Model 4501). This diode has a rather small junction capacitance (0.8 pF typical), so that its frequency response is reasonably good even in the 3- to 4-GHz range. Unfortunately, the spectral response at 1.06 μm was very poor, thereby rendering the diode not very useful for this demonstration. For laboratory use with visible wavelengths, however, this diode is probably the most desirable one.

Figure 3-5 shows the frequency response of the Philco germanium PIN diode (Model 4520). This diode has a large junction capacitance ($\sim 5\text{pF}$), and consequently worse frequency response, than the silicon PIN diode tested above. Beyond 2.6 GHz, there is not much response. However, since the diode is spectrally sensitive at 1.06- μm and can withstand much light intensity, it is still the best detector for the 1.06- μm experiments. It is therefore chosen for the 1.06- μm tests.

3.3 THE VOLTAGE CONTROLLED OSCILLATOR

Originally, the subband used for the transmission of 1-GHz bandwidth analog signals was the 3- to 4-GHz band. The performance of two VCO's operating in this band has been reported in the Third Semiannual Report (Ref. 3). Because of the poor frequency response of the photodetectors as well as the nonlinearity problems in the VCO drivers, it was decided to use the 2- to 3-GHz subband for the transmission of analog signals (see Ref. 3). For this reason, a new VCO was ordered from Omni-Spectra having a center frequency of 2.5 GHz. This VCO was received at the end of the third quarter and showed excellent performance characteristics as shown in Figure 3-6. The overall linearity over the tuning range of 2.23 to 2.275 GHz was good. In particular, over a tuning range of 160 MHz (± 80 MHz) centered at 2.5 GHz, excellent linearity is obtained. The voltage required for this ± 80 MHz deviation is only 1.5V peak-to-peak, corresponding to a drive power of 6 mW. Thus, this VCO showed much better response than any of the previous ones and is most appropriate for the FM subsystem.

3.4 THE WIDEBAND FM DISCRIMINATOR

For the demodulation of analog signals, a wideband FM discriminator is required. The design of wideband discriminators have been accomplished at LMSC; it is based on the work of Kincheloe and Wilkens (Refs. 4 and 5), who suggested the use of a microwave power divider and a 3-dB hybrid coupler connected by constant impedance transmission lines. The arrangement is a microwave analog of a one-dimensional optical interferometer; its theory of operation has been presented in the Third Semiannual Technical Report (Ref. 3).

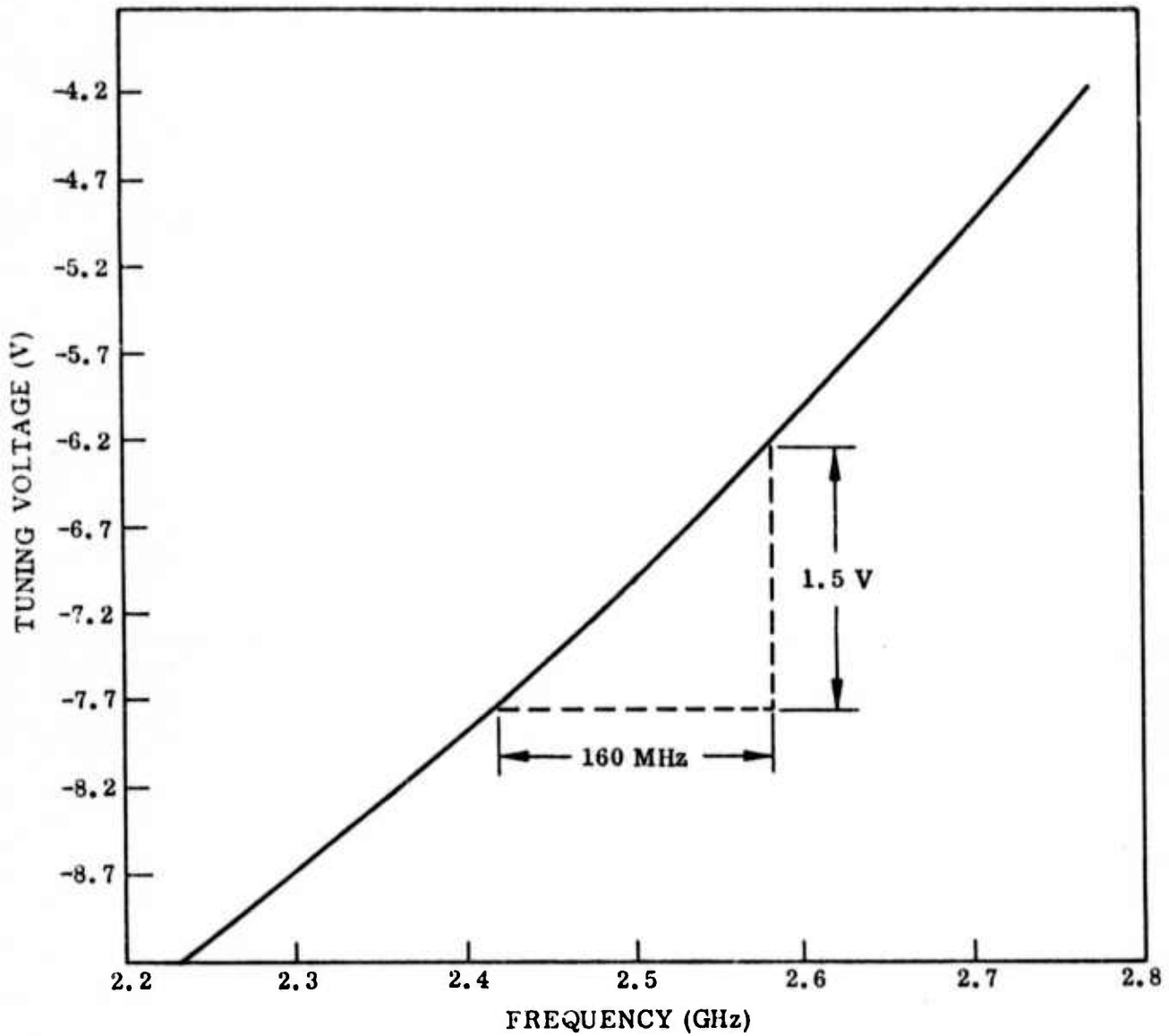

Fig. 3-9 Static Voltage Tuning Characteristics of the Final Voltage-Controlled Oscillator

During the first half year, a discriminator operating in the 3- to 4-GHz subband has been fabricated. Tests have shown good performance. However, because of the change of the frequency modulation subband, a new FM discriminator had to be fabricated. This was done this quarter, and the results are shown in Fig. 3-7. Over a deviation of ± 80 MHz, the output of the discriminator is linear. Linearity over a greater range can be obtained by carefully changing the lengths of the two interfering paths. Since this linearity range is more than adequate for the VCO, no additional work was performed.

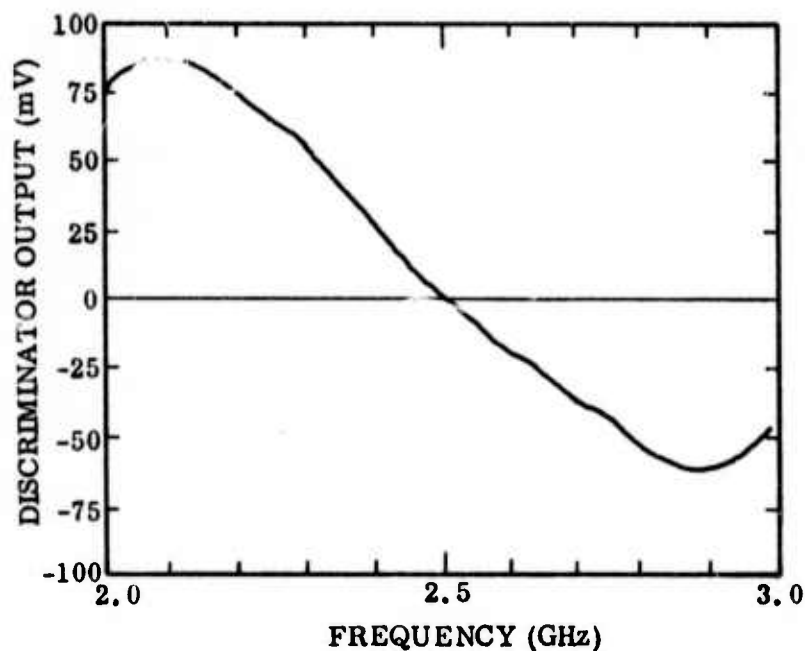

Fig. 3-7 Performance Characteristic of the Final Wideband FM Discriminator

Section 4

SYSTEM IMPLEMENTATION AND TESTS

The system layout is essentially a hardware copy of the block diagrams shown in Figs. 2-2 through 2-5. Judicious choice of amplifiers and attenuators has to be determined to ensure proper signal levels so that signal-to-noise ratios are maximized and cross-talks are minimized. The digital subsystems have been thoroughly discussed in the Third Semiannual Technical Report (Ref. 3) and will not be repeated here.

The FM subsystems have been assembled; initial tests have been carried out. Between 20-25 dB signal-to-noise ratios (picture carrier to noise) for the TV channels are typically obtained. These are considered insufficient for good display of the TV pictures (for good-quality TV pictures, typical signal-to-noise ratios are in the order of 40 dB). Thus the system is still undergoing continuous adjustment and optimization. For this reason, no detailed system-implementation block diagram is presented here. All the details will be presented in the Final Report, when the system will be optimized within the present laboratory constraints.

Section 5

CONCLUSIONS AND FUTURE PLANS

The results of this quarter's work indicate that the combined 1-GHz FM analog and 1-Gbit/sec digital data transmission is feasible over a 1.06- μ m laser link in the laboratory. Although the analog subsystem performance is still marginal, it is believed that with continuing effort during the next quarter, system performance can be greatly improved.

During the next quarter, therefore, we shall painstakingly go through the iterative steps of optimization to assure that the best obtainable signal-to-noise ratios are obtained consistent with minimum amount of intermodulation and partial reflection at component interfaces.

Section 6

REFERENCES

1. R. C. Ohlmann, W. Culshaw, K. K. Chow, H. V. Hance, W. B. Leonard, and J. Kannelaud, High-Efficiency, Single-Frequency Laser and Modulator Study, First Annual Technical Report, 30 Sep 1971, Contract No. N00014-71-C-0049, Office of Naval Research/Advanced Research Project Agency.
2. -----, High-Efficiency, Single-Frequency Laser and Modulator Study, Second Annual Technical Report, 31 Dec 1972, Contract No. N00014-71-C-0049, Office of Naval Research/Advanced Research Project Agency.
3. R. C. Ohlmann, K. K. Chow, J. J. Younger, W. B. Leonard, D. G. Peterson, and J. Kannelaud, "High-Efficiency, Single-Frequency Laser and Modulator Study," Third Semiannual Technical Report, 30 Sep 1973, Contract No. N00014-71-C-0049, Office of Naval Research/Advanced Research Project Agency.
4. W. R. Kincheloe and M. W. Wilkens, "Phase and Instantaneous Frequency Discriminators," U. S. Patent 3,395,346, Jul 30, 1968.
5. M. W. Wilkens and W. R. Kincheloe, Microwave Realization of Broadband Phase and Frequency Discriminators, Stanford Electronics Laboratory, Tech. Rep., 1962/1966-2, Nov 1968, DDC ASTIA Doc. AD 849,757.