

AD-782 468

GROWTH AND HARDENING OF ALKALI HALIDES
FOR USE IN INFRARED LASER WINDOWS

William A. Sibley, et al

Oklahoma State University

Prepared for:

Air Force Cambridge Research Laboratories
Advanced Research Projects Agency

31 October 1973

DISTRIBUTED BY:

NTIS

National Technical Information Service
U. S. DEPARTMENT OF COMMERCE
5285 Port Royal Road, Springfield Va. 22151

D D C
REFORMED
 AUG 2 1974
ADULTS
 D

Unclassified

DOCUMENT CONTROL DATA - R & D AD 782 468		
Security Classification of title, body of abstract and indexing generation must be entered when the overall report is classified.		
1. ORIGINATING AGENCY (Corporate entity) Oklahoma State University Department of Physics Stillwater, Oklahoma 74074	10. REPORT SECURITY CLASSIFICATION Unclassified	
7. REPORT TITLE GROWTH AND HARDENING OF ALKALI HALIDES FOR USE IN INFRARED LASER WINDOWS		
8. DESCRIPTIVE NOTES (Type of report and inclusive dates) Scientific Interim.		
9. AUTHOR(S) (First name, middle initial, last name) William A. Sibley John R. Hopkins Charles T. Butler Joel J. Martin		
5. REPORT DATE 31 October 1973	11. TOTAL NO. OF PAGES 24	12. NO. OF REFS 20
6a. CONTRACT OR GRANT NO. F19628-72-C-0306 6b. PROJECT, TASK, AND PROGRAM UNIT NO. 2055 n/a n/a 6c. DDC ELEMENT 61101D 6d. FUD ELEMENT n/a	13. ORIGINATOR'S REPORT NUMBER(S) Semi-Annual Technical Report No. 2 14. OTHER REPORT NUMBER (Any other numbers that may be assigned this report) AFCRL-TR-74-0156	
16. DISTRIBUTION STATEMENT A - Approved for public release; distribution unlimited		
17. SUPPLEMENTARY NOTES This research was supported by the Defense Advanced Research Projects Agency	18. SPONSORING MILITARY ACTIVITY Air Force Cambridge Research Laboratories (LQ) L. G. Hanscom Field Bedford, Massachusetts 01730	
19. ABSTRACT <p>A Reactive Atmosphere Process treatment system for KCl starting material has been placed in operation. Crystals grown from the treated material have OH⁻ contents of about 0.05 µg OH⁻ per g KCl as compared to 1 µg OH⁻ for untreated crystals. Crystals grown from the treated material are being sent to AFCRL for 10.6 µm absorption measurements. The flow stress of a series of KBr-Cl mixed crystals has been measured as a function of radiation damage. The magnitude of the increase in flow stress is approximately the same as it is in pure KCl or KBr for equivalent amounts of damage. This result shows that the radiation hardening and alloy hardening are additive. Preliminary thermal conductivity studies (internally funded) show that 400 ppm of Sr impurity causes only a small decrease in the room temperature thermal conductivity of KCl.</p>		
Reproduced by NATIONAL TECHNICAL INFORMATION SERVICE U.S. Department of Commerce Springfield VA 22151		

DD FORM 1473

Unclassified

Security Classification

Unclassified

Security Classification

REV WORDS	LINE 4		LINE 5		LINE 6	
	SOLE	BT	SOLE	BT	SOLE	BT
Alkali Halides Pure and doped KCl KCl:KBr mixed crystals Flow Stress Crystal Growth Crystal Characterization Irradiated KBr:KCl mixed crystals Thermal Conductivity						

Unclassified

Security Classification

TABLE OF CONTENTS

I. INTRODUCTION 1

II. REACTIVE ATMOSPHERIC PROCESSING. 2

III. HARDENING OF ALKALI HALIDE INFRARED LASER WINDOW MATERIALS . . 6

 1. Introduction 7

 2. Experimental Procedure 9

 3. Results and Discussion 11

 4. Summary 13

IV. THERMAL CONDUCTIVITY OF KCl:Sr 15

V. SUMMARY. 19

I. INTRODUCTION

This project was initiated to study the effects of doping and irradiation on the mechanical and optical properties of the alkali halides. A concentrated effort to study KCl has been followed since KCl is the most promising alkali halide for laser window applications. A significant part of the Oklahoma State University project is crystal growth. Doped crystals with varying amounts of impurities are grown for mechanical and irradiation studies. Systematic comparisons of crystals grown from different starting materials, in different apparatus, and under growing conditions are being made. A Reactive Atmosphere Process has been started in order to see the effects of lower OH^- contents in KCl. Another major area of the project is the investigation of mechanical properties of pure, doped, and irradiated crystals. Section II which describes this work in the manuscript of a paper to be presented at the Laser Window Materials Conference in Hyannis.

Since the thermal conductivity of the laser window material is an important parameter, an internally funded investigation of the thermal conductivity of pure, doped and irradiated KCl crystals is being carried out. Preliminary results indicate that the addition of approximately 400 ppm Sr to KCl gives only a small and probably insignificant reduction to the room temperature thermal conductivity.

II. REACTIVE ATMOSPHERIC PROCESSING

J. R. Hopkins, W. Vinson and C. T. Butler

Because of its low intrinsic absorption at $10.6 \mu\text{m}$ KCl is an excellent candidate for use as windows for CO_2 lasers. KCl crystals grown in this laboratory from untreated reagent grade starting material typically show an optical absorption coefficient between 1 and $4 \times 10^{-3} \text{ cm}^{-1}$ at $10.6 \mu\text{m}$ (1,2). The hydroxyl ion (OH^-) coupled to a K^+ ion is probably responsible for a large part of the $10.6 \mu\text{m}$ absorption in KCl. Halogen-bearing atmospheres have been found effective in reducing the OH^- content in KCl and recent evidence (3,4) indicates that treating the starting material with a halogen-bearing atmosphere lowers the $10.6 \mu\text{m}$ optical absorption to the low 10^{-4} cm^{-1} region. Early treatment methods involved passing HCl and Cl_2 gases over the starting material (5,6). Pastor and Braunstein (3) have developed a method using CCl_4 vapors in a single-apparatus process which combines purification and Bridgman growth. In their method, called Reactive Atmospheric Processing (RAP), purification is effected by the exposure of KCl powder to carbon tetrachloride vapors in an argon carrier. The method used here (also called RAP) is similar to that of Pastor and Braunstein except that CCl_4 vapors are bubbled through molten KCl in a dual-vessel, dual-apparatus process to produce Czochralski grown crystals.

The RAP treatment is carried out in the system shown in Figure 1. First, a fused silica crucible containing the untreated reagent grade KCl is placed inside a silica chamber. The furnace surrounds the silica chamber so that the KCl is exposed only to silica and CCl_4 vapors in a helium carrier. Dry helium gas passes through the system at about $15 \text{ cm}^3/\text{min}$ as the KCl is heated and cooled. The furnace temperature is increased at $300 \text{ C}^\circ/\text{h}$ until the KCl

melts and is then held steady at $850 \pm 25^{\circ}\text{C}$ during the 30 minute RAP process. When the KCl has melted the silica transfer tube carrying the helium gas is lowered and the helium is allowed to bubble through the melt. During the thirty minute treatment period the helium gas is diverted to bubble through liquid CCl_4 and thus carries CCl_4 vapors into the rest of the system. Hence, CCl_4 vapors come into direct contact with the molten KCl and the bubbling action of the carrier gas insures good mixing. After the RAP treatment the tube is pulled from the melt, the CCl_4 has been by-passed, and helium gas continues to flow through the system until the KCl has cooled to room temperature. The KCl is held in the liquid state for about 15 minutes immediately following the RAP treatment so that some of the residual reaction products are carried off by the flowing helium. After the processed KCl has cooled to room temperature, the crucible and KCl are removed from the RAP system and the solidified boule of KCl, which slips freely from the crucible, is sealed in plastic for later use. The KCl boule often has a small, slightly yellow core which is probably trapped Cl_2 gas.

Several undoped Czochralski KCl crystals have been grown from the RAP'd material. During the growth process a few carbon specks (due to the complete cracking of the CCl_4 in the RAP process) are observed when the material is first melted. However, these carbon granules quickly fall to the bottom of the ceramic crucible and no specks have been observed in the single crystals pulled from the melt.

The 204 nm ultraviolet OH^- absorption has been used to determine the OH^- content of one of the crystals grown from the RAP'd material. The OH^- content was about 0.05 $\mu\text{g/g}$ KCl; this is a factor of 20 improvement over crystals grown from reagent grade material. In order to determine the 10.6 μm absorption of these crystals, they are being sent to H. Lipson at AFCL for calorimetric measurements.

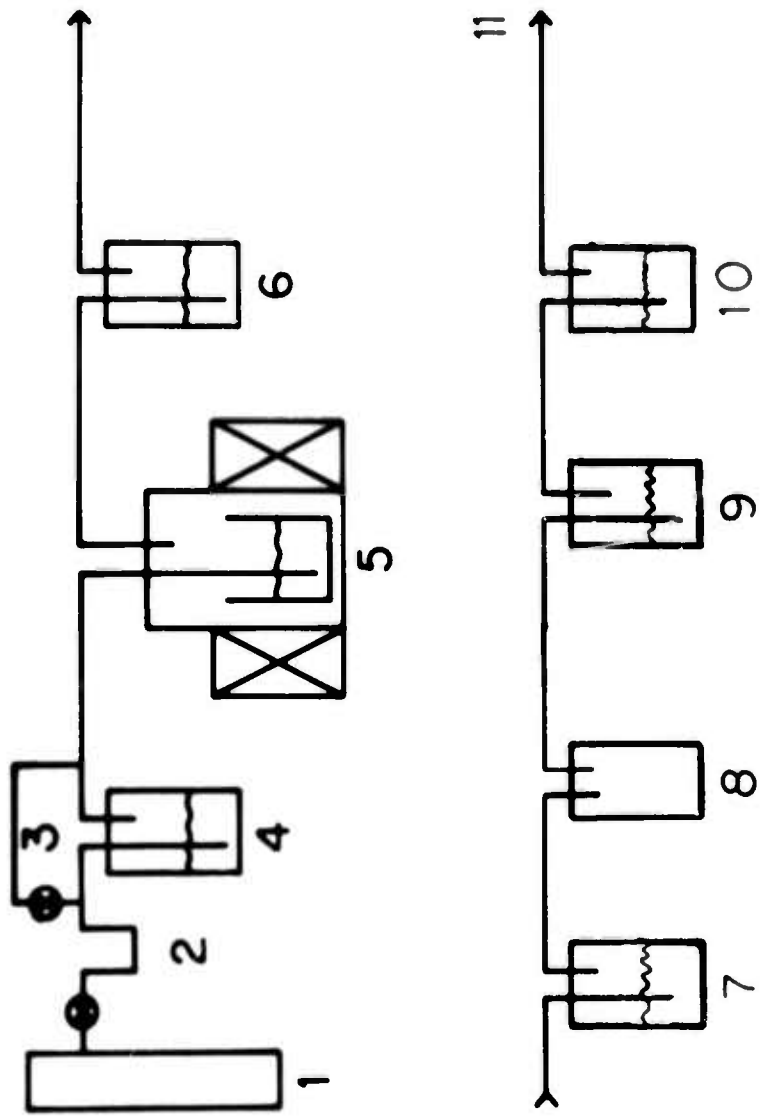

Figure 1. Block Diagram of RAP Apparatus

- 1. Helium
- 2. Drying tube
- 3. Carbon tetrachloride by-pass
- 4. Carbon tetrachloride
- 5. Furnace and reaction chamber
- 6. Empty container
- 7. Potassium hydroxide (1N)
- 8. Empty container
- 9. Ethyl alcohol
- 10. Water
- 11. Exhaust

REFERENCES

1. H. Lipson, AFCRL, Private Communication, 1973.
2. J. A. Harrington and M. Hass, NRL, Private Communication, 1973.
3. R. C. Pastor and M. Braunstein, Air Force Weapons Laboratory, Technical Report AFWL-TR-72-38, March 1972, pp. 20-25.
4. P. H. Klein, Naval Research Laboratory, Semi-Annual Technical Report ARPA Order 2031, June 1973, pp. 3-6.
5. C. T. Butler et al. ORNL Report ORNL-3906, Feb. 1966.
6. R. Capelletti, V. Fano and M. Scalvine, J. Crystal Growth 5, 73 (1969).

III. HARDENING OF ALKALI HALIDE INFRARED LASER WINDOW MATERIALS*

J. J. MARTIN, C. T. BUTLER
J. R. HOPKINS, and W. A. SIBLEY
Department of Physics
Oklahoma State University
Stillwater, Oklahoma 74074

Tetragonal defects such as divalent impurity ion-vacancy pairs and radiation induced interstitials increase the mechanical flow stress of alkali halide crystals. We have measured the change in flow stress due to Sr impurities of a series of KCl:Sr crystals and find that the increased flow stress is proportional to the square root of the Sr concentration in agreement with Fleischer's theory. A molar impurity content of 600 ppm Sr results in an engineering flow stress of 2400 psi. Our attempts to increase the Sr impurity concentration to greater than 600 - 700 ppm resulted in visible Sr precipitation within the crystals. In addition, the increase in flow stress of KCl:KBr crystal alloys due to irradiation with 1.5 MeV electrons has been monitored. Radiation produces equal numbers of F centers (negative-ion vacancies each with a trapped electron) and interstitials. It has been determined previously that, in the case of KCl, a plot of the square root of the F center concentration versus increase in flow stress gives a straight line. Since it has been shown that F centers themselves do not harden crystals, these results suggest that individual interstitial defects are effective in increasing the flow stress. Recent work by Hobbs, et al., indicates that although the interstitial defect clusters in KCl have a geometry such that each interstitial does interact with dislocations, this is not the case for KBr crystals. In KBr, the clusters are more elliptical in nature, whereas in KCl they are needle shaped. Our data on KCl:KBr irradiated alloys show that the increase in flow stress, due to irradiation, is proportional to the square root of the F center concentration just as for KCl. This result has strong implications as to the interstitial cluster shape and the radiation damage mechanism in these alloys. In crystals of $\text{KBr}_{0.67}\text{Cl}_{0.33}$, a radiation-induced F center concentration of 20 ppm increased the engineering flow stress from 2600 psi to 4000 psi. In undoped KCl,

*Supported by ARPA; monitored by AFCRL

a similar F center concentration increased the flow stress from 320 psi to 1900 psi. All tests were made on $\langle 100 \rangle$ oriented crystals under compression.

1. INTRODUCTION

Tetragonal defects such as divalent impurity ion-vacancy pairs and radiation induced interstitials increase the mechanical flow stress of alkali halide crystals. Fleischer (1) has shown that the interaction between dislocations moving along the slip plane and isolated defects increases the resolved flow stress, τ_r . The increase is given by

$$\Delta\tau_r = \frac{G}{n} C^{1/2} \quad (1)$$

where G is the shear modulus, C is the mole fraction defect concentration, and n is a number which depicts the hardening effectiveness of the particular type of defect. Fleischer found approximate n values of 10 and 100 for interstitials and divacancies, respectively. The $C^{1/2}$ dependence for Sr doped KCl has been observed by the authors as shown in Fig. 1 (2). In this system the Sr^{++} substitutes for K^+ in the KCl lattice and a positive ion vacancy is formed to preserve electrical neutrality. The resulting impurity ion-vacancy pair strengthens the crystal and the data indicate that $n \approx 40$ in Eq. 1. A molar impurity content of 600 ppm Sr results in an engineering flow stress of 2400 psi. Our attempts to increase the Sr concentration to values greater than 600 - 700 ppm resulted in visible Sr precipitation within the crystal.

Figure 1 also shows that the increase in the flow stress of irradiated KCl is directly proportional to the square root of the F center (negative-ion vacancy with a trapped electron) concentration. Earlier radiation hardening studies of a number of alkali halides (3,4,5) have also shown a $C^{1/2}$ dependence of the flow stress on F center concentration. Nadeau (3), using additive coloration, and Hopkins (6), using electrolytic coloration, have shown that F centers alone do not significantly change the flow stress. Hence, the strengthening of the irradiated alkali halides is due to the halogen interstitials produced in the radiation damage process. Figure 1 indicates that the radiation hardening of KCl is considerably more efficient than the hardening due to Sr doping. From the curve for the radiation hardened KCl, an n value of 11 is obtained; this agrees well with the value predicted by Fleischer.

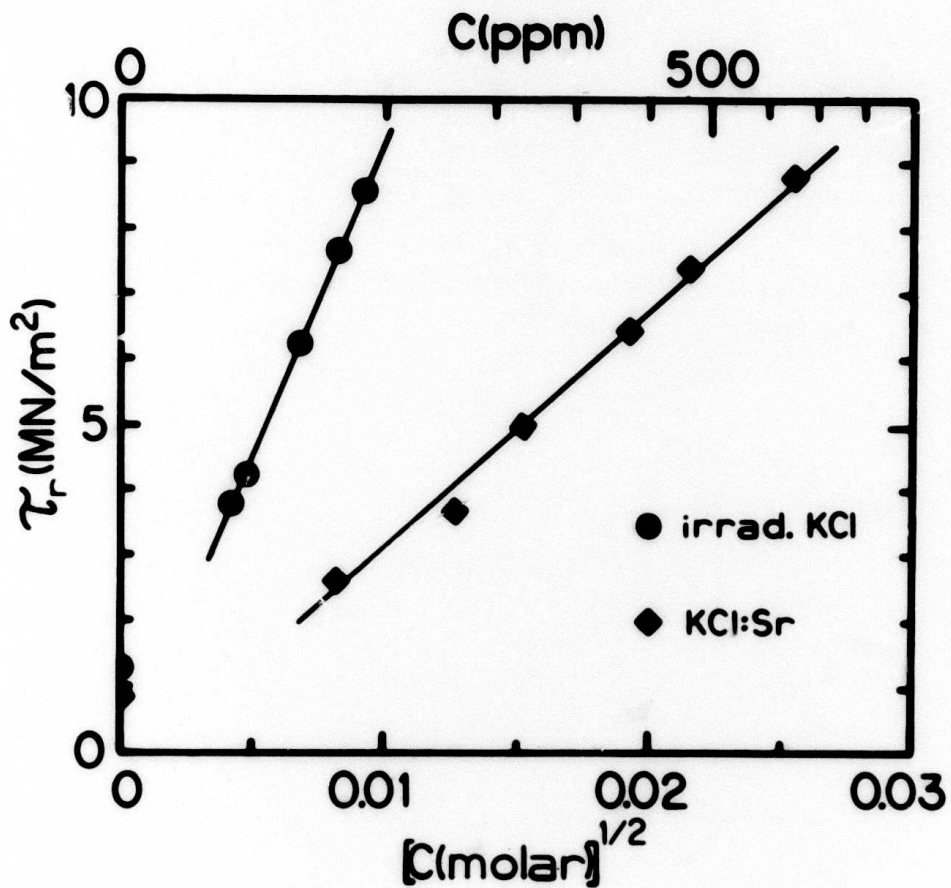

Figure 1

The resolved flow stresses, τ_r , of Sr doped KCl and of irradiated KCl are plotted as a function of the square root of the molar Sr and F center concentrations respectively. The scale on the right gives the engineering flow stress.

Recent electron microscope studies of irradiated alkali halide foils by Hobbs, Hughes, and Pooley (7) indicate that interstitials produced during room temperature irradiation cluster as prismatic dislocation loops. Hence, the hardening is not due to interactions of dislocations and individual interstitials but rather to the interactions of dislocations and interstitial clusters. The electron microscope pictures indicate that the interstitial clusters are long and narrow in KCl, are still elongated but slightly wider in KBr, and are quite rounded in KI. The widths of the clusters grow with irradiation dosage. Hobbs and Howitt (8) have shown that for the elongated dipole loops in KCl the increase in flow stress is still proportional to $C^{1/2}$:

$$\Delta\tau_r = \frac{Gb}{3k} \frac{2}{(ad)^{1/2}} C^{1/2} \quad (2)$$

where b , the Burgers vector, equals $a/2 \langle 110 \rangle$, $k = 4$ for the dislocation-dipole loop interactions, a is the lattice constant, and d is the dipole width. For KCl they found that the dipole width remained constant for the radiation doses investigated. For systems which form rounded dislocation loops, $\Delta\tau_r$ is expected to be proportional to $C^{2/3}$, and Hobbs and Howitt (8) observed this to be the case in KI. The case of KBr should be somewhat intermediate to KCl and KI.

In this work the flow stress for the KBr-KCl alloy system has been measured as a function of radiation dose. These measurements should provide information on the hardening by interstitial clusters in the transition region between the long, narrow loops in KCl and the elongated, but wider, loops in KBr.

2. EXPERIMENTAL PROCEDURE

The KCl samples used in this investigation were cleaved from an OSU, Czochralski grown, boule. The KBr samples were obtained from material purchased from Harshaw. The $\text{KBr}_x \text{Cl}_{1-x}$ samples were cleaved from Czochralski grown boules supplied by Air Force Cambridge Research Laboratories. Since "as grown" mixed KBr-Cl crystals are very brittle, the alloyed boules were annealed for 24 hours at 650°C and cooled to room temperature at a rate of 35 °C/hr before testing. Six sets of samples were cleaved from each boule to prepare for irradiation. Each set consisted of one plate (6 mm X 6 mm X 2 mm) which was used for the optical absorption measurements, and six $\langle 100 \rangle$ parallelepipeds

(1.5 mm X 1.5 mm X 8 mm) which were used for the flow stress measurements. In order to eliminate any possible bleaching effects each set was wrapped in a single layer of aluminum foil, and then was irradiated on both sides for various lengths of time in the Oklahoma State University Van de Graaff facility with 1.5 MeV electrons. A beam current density of approximately 1.5×10^{13} electrons/s \cdot cm² was used.

The flow stress of each of the six bars from each set was measured under compression on an Instron testing machine. The samples were compressed along the <100> direction at a crosshead speed of 0.05 cm/min. This corresponds to a strain rate of about 10^{-3} /s. Some tests were made on unirradiated samples at a crosshead speed of 0.005 cm/min; this slower speed gave the same flow stress result. The engineering flow stress, τ_e , was taken to be the stress value at the intersection of the tangents to the elastic and first plastic flow portions of the curve. The individual flow stresses were averaged to obtain the value reported for each set. In order to compare the results with theory, the resolved flow stress, τ_r , the component of the flow stress parallel to the primary slip direction, is needed. For the alkali halides $\tau_r = \frac{1}{2}\tau_e$. Table I lists the engineering and resolved flow stresses for the unirradiated crystals.

TABLE I. Engineering, τ_e , and Resolved, τ_r , Flow Stresses for Unirradiated $\text{KBr}_x \text{Cl}_{1-x}$ Crystals.

x	τ_e (psi)	τ_r (MN/m ²)*
1.0 (KBr)	380	1.3
0.75	2700	9.2
0.67	3360	11.5
0.50	4000	13.6
0.0 (KCl)	380	1.3

$$*1\text{MN/M}^2 = 147 \text{ psi} = 0.102 \text{ kg/mm}^2$$

The radiation dose for each set was determined by measuring the F center concentration, found from the F band optical absorption of the plate sample, with a Cary 14 spectrophotometer. The change in wavelength of the F band absorption peak with changing composition ($0 \leq x \leq 1$) was in good agreement with

the data reported by Smakula, Maynard, and Repucci (9). In agreement with Still and Pooley (10), the coloration rate of the mixed crystals was found to be considerably less than that for either pure KCl or KBr.

3. RESULTS AND DISCUSSION

The resolved flow stress, τ_r , versus the square root of the molar F center concentration, C , for the $\text{KBr}_x \text{Cl}_{1-x}$ system is shown in Figure 2. The resolved flow stress for all compositions is directly proportional to the square root of the F center concentration. However, in some of the materials, a slight softening was observed for low radiation doses. A similar observation was made by Nadeau (3) for a few of the pure alkali halides. The softening occurs during early stage coloration where few stable interstitials are thought to be produced.

Since the flow stress increases as the square root of the F center concentration for all compositions, the interstitial clusters must retain the elongated shape as x varies from 0 to 1 in the $\text{KBr}_x \text{Cl}_{1-x}$ system. The widths of the clusters may be estimated from the slopes of the τ_r versus $C^{1/2}$ curves. For the alkali halide slip system

$$G = \left[\frac{1}{2} C_{44} (C_{11} - C_{22}) \right]^{1/2}$$

where the C_{aa} 's are the elastic constants. No published elastic constants for the mixed alkali halides are known to exist; therefore, a weighted average of the G 's (calculated from tabulated elastic constants (11)) for pure KCl and pure KBr was used. Table II lists the shear moduli and the estimated cluster widths.

TABLE II. Shear Moduli, G , and Cluster Widths, d , for $\text{KBr}_x \text{Cl}_{1-x}$

x	$G (10^3 \text{ MN/m}^2)$	$d (\text{\AA})$
1.0 (KBr)	8.5	18
0.75	8.95	18
0.67	9.13	8
0.5	9.4	11
0.0 (KCl)	10.3	5

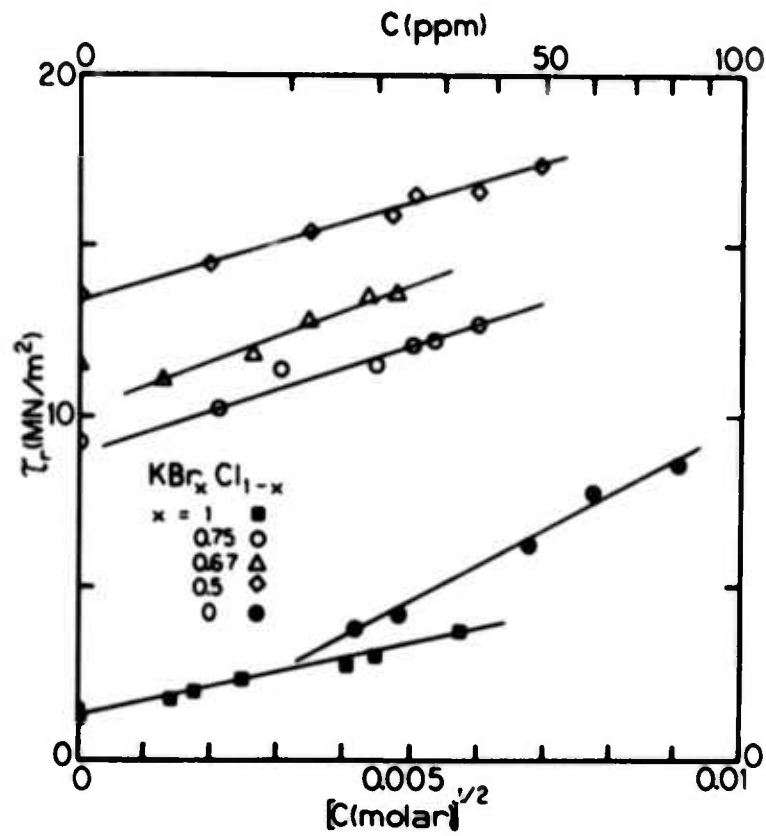

Figure 2

The resolved flow stress, τ_r , is shown as a function of the square root of the molar F center concentration for irradiated $\text{KBr}_x\text{Cl}_{1-x}$ crystals. The engineering flow stress is given on the right hand scale.

The estimated cluster width for KBr is 3 to 4 times that for KCl. This is in reasonable agreement with the electron microscope results (7). Since the mixed crystals are probably somewhat inhomogeneous, the d 's listed in Table II are not precise; hence, the fact that there is not a smooth transition from KCl to KBr is understandable. However, the general trend of the data is for decreasing cluster widths as x varies from 1 to 0 (KBr to KCl).

4. SUMMARY

The hardening of the mixed crystal system $\text{KBr}_x \text{Cl}_{1-x}$ has been measured as a function of radiation dose. According to Hobbs, Hughes, and Pooley (7), the hardening appears to be caused by the formation of interstitial clusters rather than by individual interstitials. In agreement with the electron microscope results calculations from the data presented here indicate that the interstitial clusters are long and narrow for pure KCl and become wider as the Cl^- ions are replaced by Br^- ions. Even though the mixed crystals have a much greater initial flow stress, the radiation hardening mechanism remains the same as that for the pure KCl and pure KBr crystals. This has practical implications for other infrared laser window materials; that is, it seems that irradiation can always be used to further strengthen materials that have already been hardened in other ways. The radiation hardening of press forged KCl is currently being studied to see if the large dislocation densities present in these materials alter the formation of the interstitial clusters. The authors thank Dr. John Larkin and Captain Norm Klausutis of AFCRL for the KBr-Cl mixed crystals.

REFERENCES

1. K. L. Fleischer, *Acta Met.* 10, 835 (1962).
2. W. A. Sibley, C. T. Butler, J. R. Hopkins, J. J. Martin, and J. A. Miller, AFCRL Technical Report, AFCRL-TR-73-0342 (1973).
3. J. S. Nadeau, *J. Appl. Phys.* 34, 2248 (1963).
4. W. A. Sibley and E. Sondor, *J. Appl. Phys.* 34, 2366 (1963).
5. W. A. Sibley and J. R. Russell, *J. Appl. Phys.* 36, 810 (1965).
6. J. R. Hopkins, *Phys. Stat. Sol. (a)*, 18, K15 (1973).
7. L. W. Hobbs, A. E. Hughes, and D. Pooley, *Proc. R. Soc. Lond. A* 332, 167 (1973).
8. L. W. Hobbs and E. G. Howitt, Paper presented at Europhysics Topical Conference on Lattice Defects in Ionic Crystals, Marseille-Luminy, 2-6 July 1973.
9. A. Smakula, N. C. Maynard, and A. Repucci, *Phys. Rev.* 130, 113 (1963).

10. P. P. Still and D. Pooley, *Phys. Stat. Sol.* 32, K147 (1969).
11. H. B. Huntington, *Solid State Physics*, 7, 213 (1958).

IV. THERMAL CONDUCTIVITY OF KCl:Sr

C. M. Helt and J. J. Martin

Since KCl can be significantly strengthened by the addition of Sr and since, to date, it appears that Sr doping does not significantly increase the 10.6 μm absorption; KCl:Sr might make a more suitable laser window material than pure KCl. Heat transfer in the laser window is a serious problem. It is known that small quantities of impurities can seriously degrade the thermal conductivity of a dielectric crystal. Heat transport in dielectrics is by lattice vibrations. The thermal conductivity of a pure crystal is proportional to T^3 at the very lowest temperatures where it is limited by the crystal boundaries. At temperatures above 30 K the thermal conductivity is limited by phonon-phonon scattering and should be proportional to T^{-1} at the higher temperatures. In the intermediate temperature region (10-30 K) the thermal conductivity is limited by Rayleigh type point defect scattering due to the isotopic mass difference and impurities. It is in this region that the effect of Sr doping will be the greatest. At room temperature, and above, the phonon-phonon scattering should mask most of the impurity scattering. An internally funded program has been initiated to investigate the effects of dopants and irradiation on the thermal conductivity of KCl.

The thermal conductivity measurements are being made in a conventional low temperature system^(1,2). Preliminary measurements of the thermal conductivity of undoped KCl and of KCl:Sr have been made over the 77 to 300 K temperature range. Both samples were cleaved from OSU-grown boules of untreated reagent grade KCl. The KCl:Sr sample contains 400 ± 150 ppm Sr.

Figure 1 shows the measured thermal conductivities for the two samples.

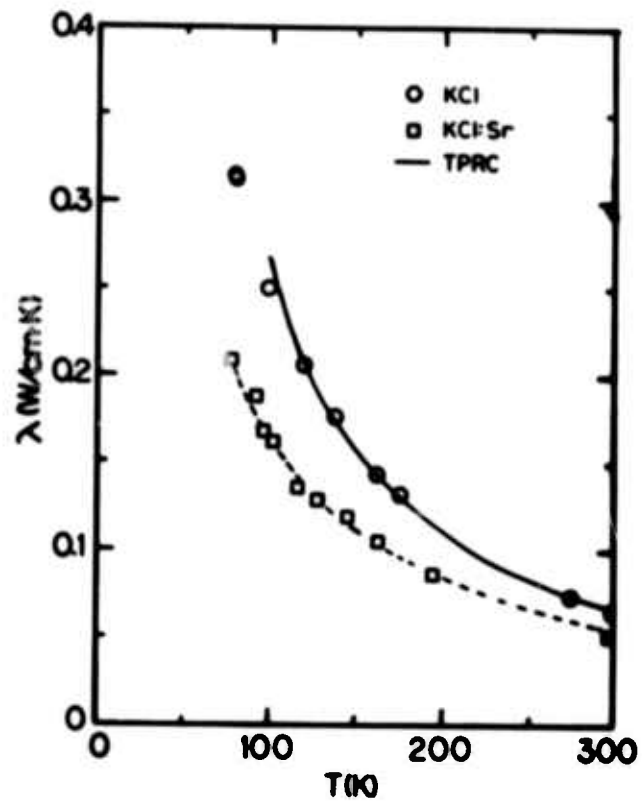

Figure 1

The thermal conductivities of KCl and KCl:Sr are shown as a function of temperature. The solid curve shows the TPRC tabulated values for pure KCl.

Our results for the undoped crystal are in excellent agreement with the data given in the TPRC (3) tables for pure KCl. The TPRC tabulation is shown as the solid curve in Figure 1. The results for the KCl:Sr crystal shows that the Sr dopant significantly lowers the thermal conductivity at liquid nitrogen temperatures. This result is to be expected since the increased point defect scattering is more significant at the lower temperatures. Near room temperature the difference in the thermal conductivities of KCl and KCl:Sr is just outside the experimental uncertainties. Slack (4) found a similar result for KCl:Ca.

REFERENCES

1. J. J. Martin, *J. Phys. Chem. Solids*, 33, 1139 (1972).
2. M. W. Wolf and J. J. Martin, *Phys. Stat. Sol (a)* 17, 215 (1973).
3. Y. S. Touloukian, R. W. Powell, C. Y. Ho, and P. G. Klemens, ed., Thermophysical Properties of Matter, The Thermophysical Properties Research Center Data Series, Vol. 2, "Thermal Conductivities of Non-metallic Solids." IFI/Plenum, N.Y. 1970, pp. 613-620.

V. SUMMARY

A Reactive Atmosphere Process treatment system for KCl starting material has been placed in operation. Crystals grown from the treated material are found to have OH^- contents of about $0.05 \mu\text{g OH}^-/\text{gKCl}$ as compared to $1 \mu\text{g OH}^-/\text{gKCl}$ for untreated material. Crystals grown from the treated material are being sent to AFCRL for $10.6 \mu\text{m}$ absorption measurements.

The flow stress of a series of KBr-Cl mixed crystals has been measured as a function of radiation damage. The magnitude of the increase in flow stress is the same as it is in pure KCl or KBr for equivalent amounts of damage. This result shows that the radiation hardening and alloy hardening mechanisms are additive.

An internally funded project to determine the effects of dopants and irradiation on the thermal conductivity of KCl has been initiated. Preliminary results show that 400 ppm Sr causes only a small decrease in the room temperature thermal conductivity of KCl.

Publications resulting from this work: J. R. Hopkins, "Comparison of Vacancy and Interstitial Hardening in KCl" Phys. Stat. Sol. (a) 18, K15 (1973); J. A. Miller, J. R. Hopkins and J. J. Martin, "Flow Stress, Vickers Hardness and Wing Size for Pure and Doped KCl and for KCl:KBr Mixed Crystals" accepted by Phys. Stat. Sol. (a).