

AD-782 950

DEGRADATION OF POLYMERS AT LOW  
TEMPERATURES BY NO<sub>2</sub>, O<sub>3</sub> AND NEAR-UV  
RADIATION

H. H. G. Jellinek

Cold Regions Research and Engineering  
Laboratory

Prepared for:

Advanced Research Projects Agency

25 June 1974

DISTRIBUTED BY:

**NTIS**

National Technical Information Service  
U. S. DEPARTMENT OF COMMERCE  
5285 Port Royal Road, Springfield Va. 22151

Unclassified  
Security Classification

AD 782 950

DOCUMENT CONTROL DATA - R & D		
<i>Security classification of title, body of abstract and indexing annotation must be entered when the overall report is classified</i>		
1. ORIGINATING ACTIVITY (Corporate author) U.S. Army Cold Regions Research and Engineering Laboratory Hanover, New Hampshire 03755		2a. REPORT SECURITY CLASSIFICATION Unclassified
3. REPORT TITLE DEGRADATION OF POLYMERS AT LOW TEMPERATURES BY NO <sub>2</sub> , O <sub>3</sub> AND NEAR-UV RADIATION		2b. GROUP
4. DESCRIPTIVE NOTES (Type of report and inclusive dates)		
5. AUTHOR(S) (First name, middle initial, last name) H.H.G. Jellinek		
6. REPORT DATE 25 June 1974	7a. TOTAL NO. OF PAGES <del>29</del> 31	7b. NO. OF REFS 7
8a. CONTRACT OR GRANT NO. ARPA Order 1615	8b. ORIGINATOR'S REPORT NUMBER(S) RR 321	
8. PROJECT NO.	8c. OTHER REPORT NO(S) (Any other numbers that may be assigned this report)	
10. DISTRIBUTION STATEMENT Approved for public release; distribution unlimited.		
11. SUPPLEMENTARY NOTES		12. SPONSORING MILITARY ACTIVITY Advanced Research Projects Agency 1400 Wilson Blvd. Arlington, Va. 22209
13. ABSTRACT A tensile strength, a static and a dynamic stiffness tester have been constructed for measuring appropriate mechanical properties of polymers as a function of temperature, environmental conditions (i.e. air plus NO <sub>2</sub> , O <sub>3</sub> etc. or of the pollutants alone), exposure time and pollutant concentration. The apparatus were found to perform satisfactorily. The dynamic stiffness tester is particularly sensitive to the onset of cracking in polymeric materials due to ozone. The tensile strength of linear polyurethane was affected appreciably by NO <sub>2</sub> alone and also by NO <sub>2</sub> in presence of air. Chain scission cross-linking, evolution of CO <sub>2</sub> and other small molecular weight compounds, and formation of nitro and nitroso groups along the polymer backbone are reactions underlying the observed changes in mechanical properties of the polymer. The static "stiffness" tester allows one to measure "stiffness" (Young's modulus) of polymers (especially elastomers) as a function of the above-mentioned parameters. A preliminary selection of polymeric skirting materials for SEV's can be made on the basis of results obtained as functions of temperature. Two industrial samples appeared to be suitable for this purpose on the basis of results obtained. "Stiffness" of these samples started to increase rapidly only at -40°C and -30°C whereas others became brittle at higher temperatures. The dynamic stiffness tester was tested with		

DD FORM 1473

REPLACES DD FORM 1473, 1 JAN 64, WHICH IS OBSOLETE FOR ARMY USE.

Reproduced by  
NATIONAL TECHNICAL  
INFORMATION SERVICE  
U S Department of Commerce  
Springfield VA 22151

Unclassified  
Security Classification

KEY WORDS	LINK A		LINK B		LINK C	
	ROLE	WT	ROLE	WT	ROLE	WT
<p>Low temperature tests Stiffness tests Surface effect vehicles Tensile strength Tensile testers</p> <p>13. Abstract (cont'd)</p> <p>a natural rubber compound because of its susceptibility to ozone. Onset of cracking was accurately and clearly indicated by this instrument. An EPM compound proved quite resistant to ozone over prolonged periods of time. Time did not allow tests to be completed on all the compounds supplied by industry.</p> <p style="text-align: center;"><i>ia</i></p>						

DEGRADATION OF POLYMERS AT  
LOW TEMPERATURES BY  $\text{NO}_2$ ,  $\text{O}_3$   
AND NEAR-UV RADIATION

H.H.G. Jellinek

June 1974

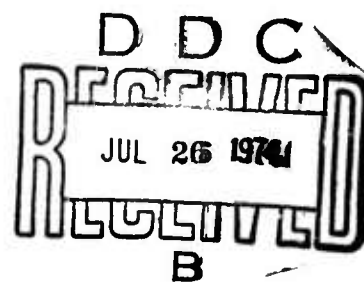

PREPARED FOR  
ADVANCED RESEARCH PROJECTS AGENCY  
ARPA ORDER 1615

BY

CORPS OF ENGINEERS, U.S. ARMY  
COLD REGIONS RESEARCH AND ENGINEERING LABORATORY  
HANOVER, NEW HAMPSHIRE

ib

APPROVED FOR PUBLIC RELEASE; DISTRIBUTION UNLIMITED.

## PREFACE

This report was prepared by Dr. H.H.G. Jellinek, Professor of Chemistry, Clarkson College of Technology.

The work was performed for the U.S. Army Cold Regions Research and Engineering Laboratory under Grant DACA 89-71-C-0027 as part of the Arctic Surface Effect Vehicle program of the Advanced Research Projects Agency (ARPA Order 1615).

The author wishes to acknowledge the assistance of Research Associates Dr. H. Kachi and Dr. H. Wegener and Research Assistants Dr. T.J.Y. Wang and F. Martin.

Technical review of the report was performed by Dr. K.F. Sterrett, Chief, Research Division, USA CRREL, Project Officer of the SEV program.

The contents of this report are not to be used for advertising, publication, or promotional purposes. Citation of trade names does not constitute an official endorsement or approval of the use of such commercial products.

*Manuscript received 30 November 1973.*

## CONTENTS

	Page
Introduction .....	1
Tensile strength apparatus .....	2
Synthesis of linear polyurethane .....	3
Tensile strength of polyurethane films .....	4
Preparation of films and technique of measuring tensile strength .....	4
Results .....	5
Effect of NO <sub>2</sub> on polyurethane films .....	7
Stiffness testers .....	10
Static apparatus .....	10
Experimental results .....	12
Dynamic "stiffness" tester .....	15
Summary .....	22
Conclusion .....	22
Literature cited .....	23
Abstract .....	25

## ILLUSTRATIONS

## Figure

1. Tensile strength apparatus .....	2
2. Tensile strength of 30- $\mu$ -thick polyurethane films vs exposure time, 5 mm Hg of NO <sub>2</sub> at 22°C .....	5
3. Tensile strength of 30- $\mu$ -thick polyurethane films vs exposure time, 5 mm Hg of NO <sub>2</sub> plus 1 atm air at 10°C .....	5
4. $\ln(S - S_f)/(S_0 - S_f)$ vs exposure time for data in Figure 2 .....	6
5. Arrhenius plot of slopes vs 1/T .....	6
6. Tensile strength of 30- $\mu$ -thick polyurethane films vs temperature for various exposure times .....	6
7. High vacuum apparatus .....	8
8. Reaction vessel assembly .....	8
9. Arrangement for polymer films on glass slides .....	8
10. Apparatus for fractionation of CO <sub>2</sub> .....	8
11. $\alpha$ vs exposure time of 15- $\mu$ -thick linear polyurethane films, 20 mm Hg of NO <sub>2</sub> .....	9
12. Cross-linking coefficient $\delta'$ vs exposure time for 15- $\mu$ -thick linear polyurethane, 20 mm Hg of NO <sub>2</sub> .....	9
13. Rate constant for chain scission as a function of film thickness, 20 mm Hg of NO <sub>2</sub> , 25°C .....	10
14. Production of CO <sub>2</sub> as a function of exposure time, 20 mm Hg of NO <sub>2</sub> .....	10
15. Static "stiffness" tester .....	11
16. Calibration of transducer; force vs scale divisions .....	11
17. Calibration of transducer; weight vs movement of glass probe .....	11
18. "Stiffness" vs temperature for various samples .....	13
19. "Stiffness" vs temperature for Du Pont Hytrel 4055 and 5550 .....	14
20. Effect of ozone on Goodrich natural rubber compound 45016-3, 25°C .....	14

Figure	Page
21. Dynamic "stiffness" tester.....	15
22. Recording trace of dynamic tester .....	16
23. Details of eccentric rotor and sample .....	16
24. Natural rubber compound (Goodrich 45016-3) specimens exposed to ozonized air ( $O_3$ about 59 ppm) in dynamic tester at different temperatures .....	18

### TABLES

Table	Page
I. Dimensions and % of permanent set of samples .....	14
II. Dimensions, temperatures and applied voltages for specimens of Goodrich Natural Rubber Compound 45016-3 tested in the dynamic "stiffness" tester.....	20
III. Natural Rubber Compound (Goodrich 45016-3) tested with dynamic instrument in presence of ozonized air ( $O_3$ about 59 ppm) at various temperatures .....	21

## DEGRADATION OF POLYMERS AT LOW TEMPERATURES BY NO<sub>2</sub>, O<sub>3</sub> AND NEAR-UV RADIATION

by

H.H.G. Jellinek

### INTRODUCTION

Various polymers were investigated to ascertain their suitability as skirting materials for surface effect vehicles (SEV's) to be used in arctic regions. It was anticipated that engine emissions close to the skirting material of the SEV's would have deteriorating effects on it, especially in conjunction with near-UV radiation and the ozone contained in the arctic air. It is known from previous experiments by the author and co-workers<sup>1, 2, 3</sup> that nitrogen oxides (e.g. NO<sub>2</sub>) in conjunction with near-UV radiation ( $\lambda > 2800 \text{ \AA}$ ) and small amounts of ozone cause chain scission, cross-linking, or both, and incorporation of oxide, nitro and nitroso groups, especially in the case of elastomers.

The polymers chosen for investigation had good mechanical and rheological properties at the temperatures likely to be encountered in arctic regions. Polyurethanes, for instance, have good low temperature properties but are not elastomers as such. Much work was carried out with a linear polyurethane to gather useful information of a preliminary nature and to devise techniques and test suitable instruments.

The work, which in many respects could not be brought to its final conclusion because of the limited time available, concentrated on several different aspects relevant to the project:

1. The construction of a tensile strength measuring apparatus which is useful for a range of temperatures and gaseous environments (air plus O<sub>3</sub>, NO<sub>2</sub>, UV radiation, etc.).
2. Synthesis of a linear polyurethane.
3. Investigation of the tensile strength of this polyurethane polymer in the presence of deleterious gases (e.g. NO<sub>2</sub>) as a function of gas concentration, temperature and exposure time.
4. A study of the effect of NO<sub>2</sub> on polyurethane films from the standpoint of chain scission, cross-linking and evolution of small molecular weight compounds. This study was only in part supported by the present project, but its main results are summarized here to aid in understanding data obtained in other areas.
5. Construction of a novel static "stiffness" tester for the study of the effect of different environments on polymers as a function of gas concentration, temperature and exposure time. These tests yield, in effect, Young's moduli of the materials under different conditions and give a measure of the deterioration of such materials.
6. Construction of a novel dynamic "stiffness" tester. Here again the variables mentioned above can be studied.

7. Data on various polymeric materials (polyurethane and elastomers supplied by industry – believed especially suitable as skirting materials) obtained with these stiffness testers.

These aspects of the work are discussed in this final report, which includes many of the construction data and measurements given in previous progress reports. This provides a continuous and largely self-contained final report of the entire project.

### TENSILE STRENGTH APPARATUS

The tensile strength apparatus (Fig. 1) consists of a stainless steel spring by which a tensile force is applied to a stretched polymer film (applied force about 20 to 5000 g). Changes in this force can be measured as a function of time and under various adverse "environmental" conditions. Stress relaxation will take place and the applied force will have to be decreased to keep the extension of the film constant. This decrease of stress with time allows one to calculate the extent of chain scissioning and cross-linking (for the latter a rapid extension method has to be used). Tensile strength measurements can also be performed with this apparatus. Due to the limited time period of the project and the development of the "stiffness" testers, the apparatus was only used to measure the ultimate tensile strength of polyurethane as a function of pollutant gas concentration, temperature and exposure time. The other measurements mentioned above could, in principle, be performed using elastomers (rubbers).

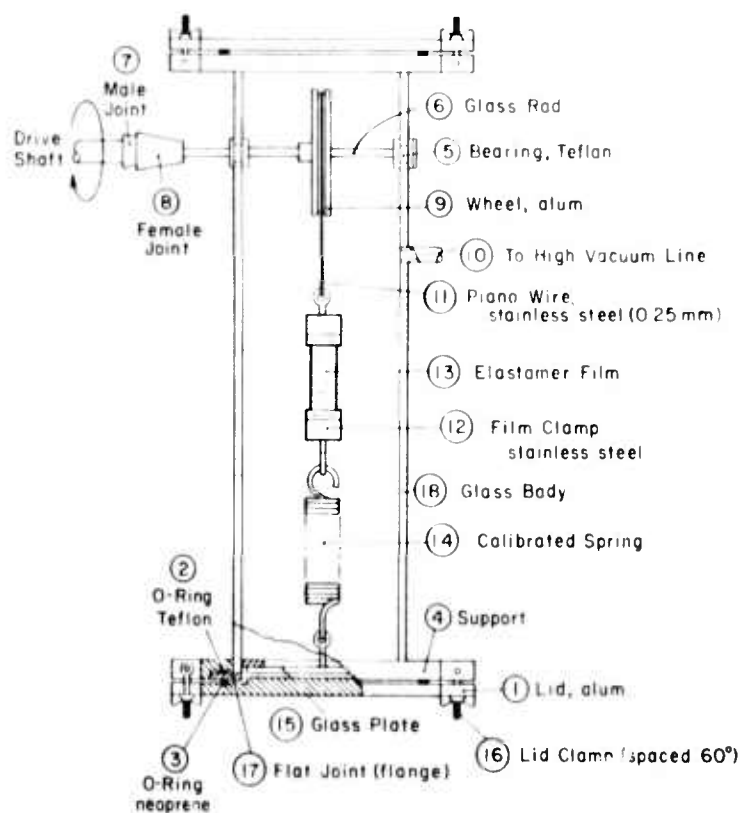

Figure 1. Tensile strength apparatus (new version with glass axle).

The apparatus can be filled with  $\text{NO}_2$ ,  $\text{O}_3$  or other gases and 1 atm of air at various small pressures. The film can also be irradiated by near-ultraviolet light. The assembled apparatus is placed in a thermostated box ( $\pm 0.5^\circ\text{C}$ ; temperature range of the box used reached down to  $-50^\circ\text{C}$ ). The extension of the spring can be measured through the glass envelope by means of a cathetometer to 0.005 cm. The box was located in a coldroom and the apparatus was connected by glass tubing to a mercury diffusion pump backed by a rotary oil pump, both of which were outside the coldroom.

It was found that a really high vacuum ( $10^{-5}$  mm Hg) could not be obtained with the first version of the apparatus which had a Teflon axle. Therefore a glass rod carrying a ground glass joint was inserted in its place. The latter served the same purpose as the Teflon rod had, i.e. to actuate the metal spring (obtained from John Chatillon, Inc., New York City). With this arrangement, a satisfactory vacuum could be obtained. The joint (glass rod) was rotated by means of a wheel 10 cm in diameter in conjunction with a worm gear 2 cm in diameter. Experiments with the new version of the apparatus were carried out at various temperatures and exposure times in pure, low pressure  $\text{NO}_2$ , and in air containing small amounts of  $\text{NO}_2$ . Hooker Fluorolube No. GR-544 grease was used at room temperature for the ground glass joint of the side arm carrying the rotating glass axle and Fluorolube No. GR-362 was used for lower temperatures, down to  $-28^\circ\text{C}$ . Fluorolube No. GR-544 was used for the flat joints and other joints at all temperatures. The spring (14) was 9.715 cm long and was made of special steel with a very small temperature coefficient. It was calibrated with weights at various temperatures in the thermostated box. Extension of the spring plotted versus load in grams over a range from 0 to 2500 g gave a straight line at each temperature as indicated by the data given below:

$^\circ\text{C} (\pm 0.5^\circ\text{C})$	-33.0	-18.0	+23.0
$10^3 \times \text{force constant (cm/g)}$	2.475	2.490	2.520

Loads could be measured within 0.2 g and extensions to 0.005 cm; temperature was constant within  $\pm 0.5^\circ\text{C}$  at any one temperature down to  $-45^\circ\text{C}$ .

It can be seen that the temperature coefficient of the force constant for the spring is practically negligible ( $3.3 \times 10^{-2}$  % change per  $^\circ\text{C}$ ). Hence, an average value of  $2.5 \times 10^{-3}$  cm/g was taken for all experiments, irrespective of temperature. The force constants plotted versus temperature gave a straight line.

The proper working of the whole apparatus was actually tested by measuring the extension of polyethylene films in various atmospheric environments. These results are of no importance for the present work and will not be reported here.

### SYNTHESIS OF LINEAR POLYURETHANE

Linear polyurethane was prepared by condensing tetramethylene glycol with hexamethylene-dicarbamate according to the melt method.<sup>6</sup> The condensation reaction is as follows:

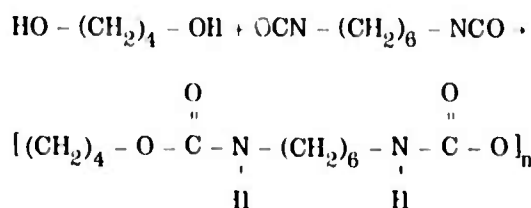

The synthesis proceeded as follows. A 200-ml three-necked flask was fitted with a  $\text{CuCl}_2$  drying tube and a steel stirrer. The flask was charged with 10.17 ml of tetramethylene glycol. The third neck of the flask was fitted with a nitrogen inlet tube and the system was flushed with a low pressure stream of nitrogen. Subsequently, the inlet tube was replaced by a stoppered, pressure-equalizing dropping funnel containing 19.17 g of hexamethylene di-isocyanate. The flask was heated to  $90^\circ\text{C}$ . Di-isocyanate was added under rapid stirring over a period of one hour. During this time, the temperature was raised to  $195^\circ\text{C}$ . The reaction was continued at this temperature until a solid mass was obtained, at which time the heating was stopped. The polymer was removed by breaking the flask and washed with methanol to remove glass and dust. It was then dissolved in *m*-cresol (0.5%). The polymer was twice precipitated with ethyl alcohol, then washed with methanol and finally with ether. It was dried in a high vacuum ( $10^{-5}$  mm Hg) for three days.

The polymer was a white powder and had no odor; its density was about  $1.2 \text{ g/cm}^3$  and its melting point was above  $190^\circ\text{C}$ .

One solvent is formic acid above  $55^\circ\text{C}$  (the sample did not go completely into solution, the small residue was filtered off). Other solvents for this polymer are any combination from 90:10 to 70:30 of phenol: $\text{H}_2\text{O}$  by volume, 50:50 by volume of *m*-cresol:toluene, and phenol above  $40^\circ\text{C}$ .

The intrinsic viscosity was  $[\eta] = 1.1 \text{ dl/g}$  in 90:10 phenol: $\text{H}_2\text{O}$  by volume at  $25^\circ\text{C}$ . Its tensile strength amounted to  $104 \text{ kg/cm}^2$  at  $22^\circ\text{C}$  measured with the metal spring apparatus described above; this is of the right magnitude for such polymers.

### TENSILE STRENGTH OF POLYURETHANE FILMS

#### Preparation of films and technique of measuring tensile strength

Two hundred and fifty milligrams of purified polyurethane was dissolved in 10 ml of a phenol:water mixture (9:1 by volume). The homogeneous solution was cast on a glass plate ( $15 \times 7.5 \text{ cm}$ ); the plate was thoroughly cleansed with chromic acid, water and reagent-grade ethyl alcohol. The films were dried at  $60^\circ\text{C}$  for 24 hours and subsequently in vacuum ( $10^{-2}$  mm Hg) at  $60^\circ\text{C}$  for 48 hours. The films could easily be removed from the plates; they were about  $30 \mu$  thick (all film strips used for tensile experiments were within 6% of this thickness).

The drying technique was later improved and made more reproducible; in addition, all rupture data were eventually expressed in terms of tensile strength. This was done by ascertaining in each case the thickness of the film of constant surface area by weighing. The length of the film between the clamps was 25 mm. The film stretched only slightly (about 2 mm) before rupture occurred. Knowing the density of the polymer, the thickness of the film could be calculated for each case.

A film ( $3.5 \times 1.3 \times 0.003 \text{ cm}$ ) was clamped in such a way that the length of the free film was always 2.5 cm. The clamps were mounted in rectangular depressions located a definite distance apart in a wooden board. The clamps holding the film were subsequently fixed to the tensile strength apparatus (Fig. 1). Only the weight of the spring and of one clamp (102 g) was exerted on the film during this time. The whole glass apparatus was then evacuated and the desired temperature was eventually obtained.

$\text{NO}_2$  pressure was obtained by keeping solid or liquid  $\text{NO}_2$  at such a temperature that its vapor pressure equalled the desired  $\text{NO}_2$  pressure (e.g. 5 mm Hg of  $\text{NO}_2$  at  $-45.5^\circ\text{C}$ ). The tensile strength apparatus compartment was connected with a large volume of the high vacuum apparatus (20.7 liters) to ensure that the  $\text{NO}_2$  pressure would remain constant during exposure.  $\text{NO}_2$  was consumed by the film while it was exposed. The procedure adopted was as follows. The apparatus compartment was

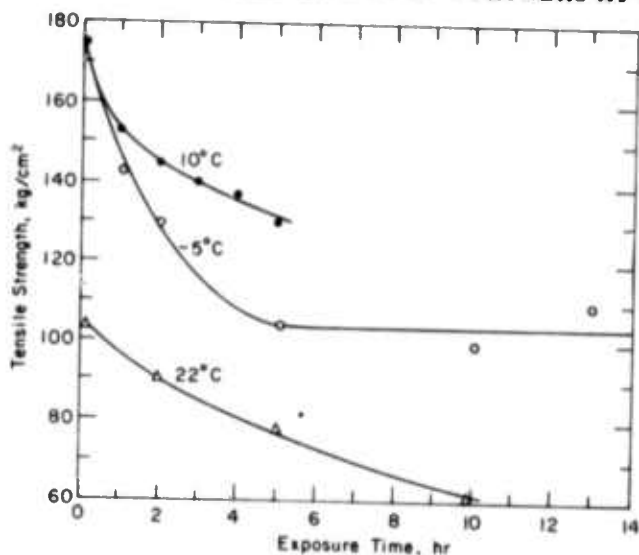

Figure 2. Tensile strength of 30- $\mu$ -thick polyurethane films vs exposure time, 5 mm Hg of  $\text{NO}_2$  at 22°C.

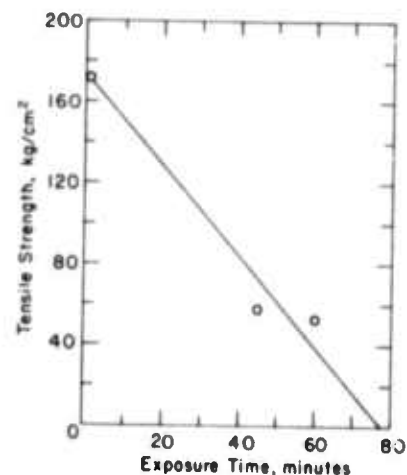

Figure 3. Tensile strength of 30- $\mu$ -thick polyurethane films vs exposure time, 5 mm Hg of  $\text{NO}_2$  plus 1 atm air at 10°C.

left evacuated, being shut off by a stopcock from the rest of the vacuum system. The large volume was then charged with 5.39 mm of  $\text{NO}_2$  ( $-44.5^\circ\text{C}$ ). When air was also used, it was introduced after being dried by passing through silica gel. The air was introduced very slowly (2 to 3 hours) into the volume containing  $\text{NO}_2$  and left standing afterwards for one to two hours. Then this air- $\text{NO}_2$  mixture was allowed to flow into the tensile apparatus compartment. The  $\text{NO}_2$  pressure finally was exactly 5 mm in the whole system. The air pressure was about 7% lower than atmospheric, but this had little effect on the reaction. The spring was expanded about 30 seconds before rupture time by rotating the axle by actuating the worm gears. This expansion was followed with the cathetometer until the breaking point of the film was reached. The expansion of the spring produced the force applied to the film.

### Results

Tensile strength plotted versus exposure time to  $\text{NO}_2$  or  $\text{NO}_2$  plus air at various temperatures is shown in Figures 2 and 3. It is apparent that the tensile strength decreases with exposure time at any one temperature and  $\text{NO}_2$  pressure. This decrease is much faster in 5 mm Hg of  $\text{NO}_2$  plus air than in 5 mm Hg of  $\text{NO}_2$  only, at the same temperature.

The curves obey the following relation:

$$-\frac{dS}{dt} = k(S - S_f) \quad (1)$$

where  $S$  is the tensile strength at time  $t$  and  $S_f$  is the final strength at  $t \approx \infty$ . Integration of eq 1 gives

$$\ln\left(\frac{S_0 - S_f}{S - S_f}\right) = kt. \quad (2)$$

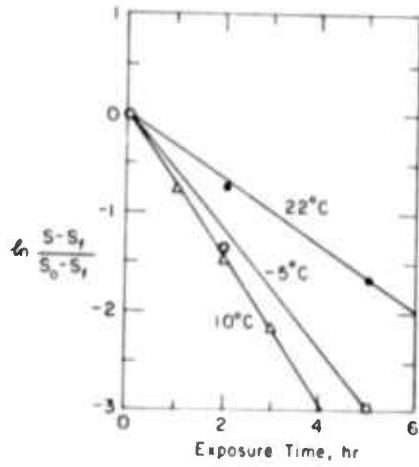

Figure 4.  $\ln (S - S_f)/(S_0 - S_f)$  vs exposure time for data in Figure 2.

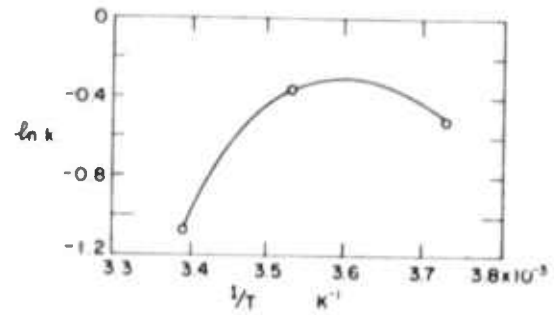

Figure 5. Arrhenius plot of slopes (Fig. 4) vs  $1/T$ .

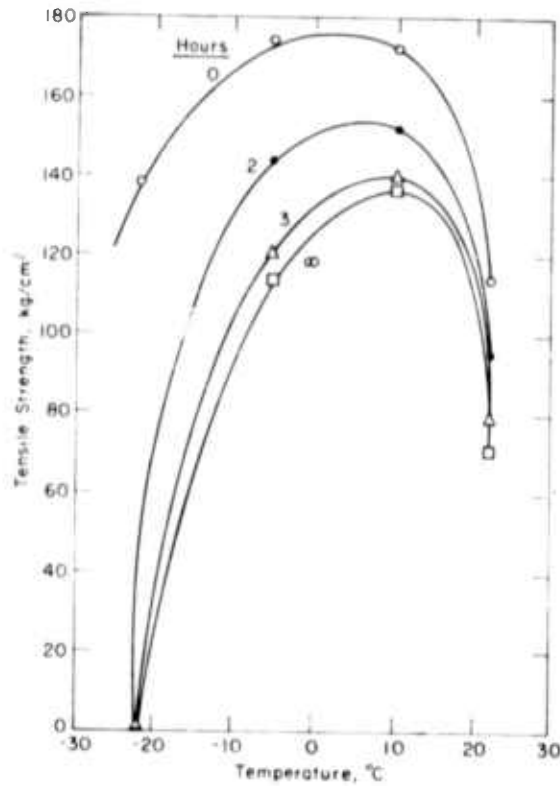

Figure 6. Tensile strength of 30- $\mu$ -thick polyurethane films vs temperature for various exposure times.

Here  $S_0$  is the tensile strength at  $t = 0$ .  $\ln(S - S_t)/(S_0 - S_t)$  vs  $t$  in hours is plotted in Figure 4. The  $k$  values are as follows:

	$-5^\circ\text{C}$	$+10^\circ\text{C}$	$+22^\circ\text{C}$
$k(\text{hr}^{-1}; 0.5 \text{ mm Hg of NO}_2)$	0.60	0.75	0.33

The rate constants pass through a maximum near  $+10^\circ\text{C}$ ; at about this temperature there must be some transition point for the structure of the polymer. The same phenomenon is brought out in the Arrhenius plot ( $\ln k$  vs  $1/T$  where  $T$  is the absolute temperature; Figure 5). The same behavior is illustrated by plotting the tensile strength vs the temperature in  $^\circ\text{C}$  for various exposure times (Fig. 6). Here again, the maximum near  $10^\circ\text{C}$  is clearly apparent. The maxima seem to shift slightly to higher temperatures with increasing exposure times.

The slope for the decrease in tensile strength  $S$  in the presence of air plus 0.5 mm Hg of  $\text{NO}_2$  at  $10^\circ\text{C}$  amounts to  $130 \text{ kg/cm}^2 \text{ hr}$ , whereas the corresponding initial slope in 0.5 mm  $\text{NO}_2$  only at  $10^\circ\text{C}$  amounts to about  $24 \text{ kg/cm}^2 \text{ hr}$ .

It is quite apparent from these experiments that the tensile strength of this linear polyurethane polymer is markedly affected by exposure to 0.5 mm Hg of  $\text{NO}_2$  ( $\sim 700 \text{ ppm}$ ) and more so by air plus  $\text{NO}_2$ . The polymer passes through a maximum when the temperature is around  $+10^\circ\text{C}$ , indicating that a transition in mechanical properties takes place in this temperature region.

#### EFFECT OF $\text{NO}_2$ ON POLYURETHANE FILMS\*

Polyurethane films (the same polymer as used previously) were exposed in a high vacuum apparatus (Fig. 7, 8). The films were cast on microscope slides from phenol:water (90:10 by volume). The solvent was allowed to evaporate under vacuum at  $105^\circ\text{C}$  and a gentle stream of nitrogen was used to prevent degradation. The films were about  $15 \mu$  thick in most cases. The effect of film thickness was also investigated (see below). For the determination of IR spectra, the polymer was cast from *m*-cresol solutions onto sodium chloride plates (these films were about  $10 \mu$  thick).

The films on the microscope slides were eventually thoroughly dried in a vacuum ( $10^{-5} \text{ mm Hg}$ ) at  $35^\circ\text{C}$  for 48 hours before dry  $\text{NO}_2$  gas was introduced into the reaction vessel (20 mm and 2 mm Hg of  $\text{NO}_2$ , respectively); the temperature range for these exposures was  $15^\circ$  to  $60^\circ\text{C}$  (Fig. 9). Intrinsic viscosities were measured after exposure as a function of exposure time, gas concentration and temperature. In the case of cross-linking, gel fractions were determined by weighing.  $\text{CO}_2$  was evolved during exposure. This gas was determined as a function of exposure time etc. by first condensing  $\text{NO}_2$  at  $-75^\circ\text{C}$ ;  $\text{CO}_2$  was then solidified by liquid nitrogen using the apparatus shown in Figure 10 (vessel G was immersed in liquid nitrogen). Eventually vessel G was sealed off at point F, and  $\text{CO}_2$  was determined chromatographically.

Figure 11 shows the degree of degradation  $\alpha$ , which is a measure of the extent of chain scission (at zero scission  $\alpha = 0$ , at complete scission  $\alpha = 1.0$ ), plotted versus exposure time at various temperatures. The  $\text{NO}_2$  pressure was 20 mm Hg. The shapes of the curves indicate that initially chain scission takes place ( $\alpha$  increases), then cross-linking occurs ( $\alpha$  decreases), the polymer becomes partly insoluble and a gel fraction is formed. Eventually the cross-links are ruptured and the polymer becomes completely soluble again ( $\alpha$  increases).

The same behavior is indicated in a plot of the cross-linking coefficient  $\delta'$  which is a measure of the amount of cross-linking (Fig. 12). It was also shown that the reaction is diffusion-controlled

\* Summary; for details see ref. 4.

## DEGRADATION OF POLYMERS AT LOW TEMPERATURES

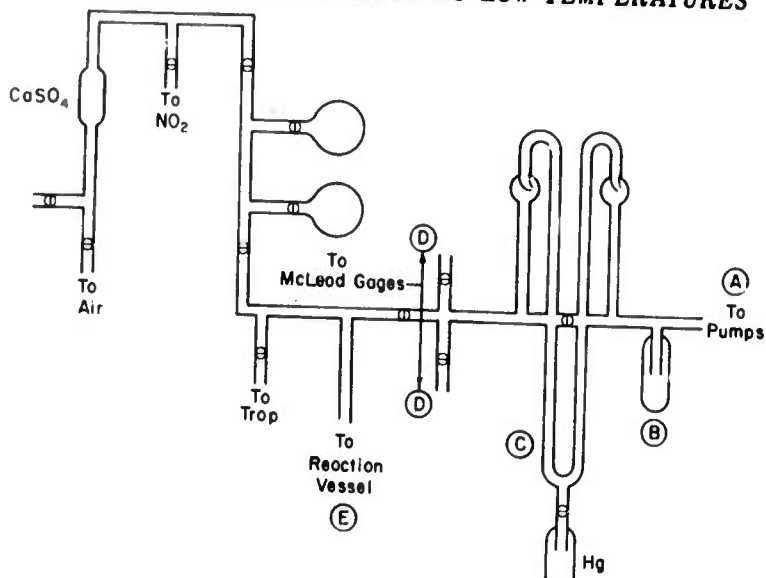

Figure 7. High vacuum apparatus.

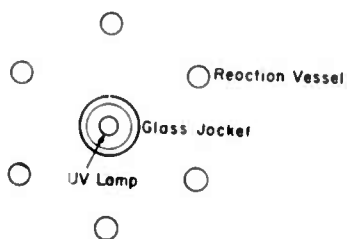

Figure 8. Reaction vessel assembly (also for experiments for exposure to UV radiation).

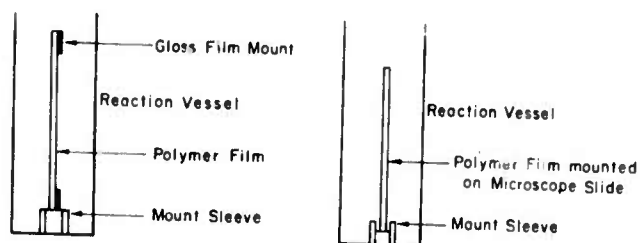
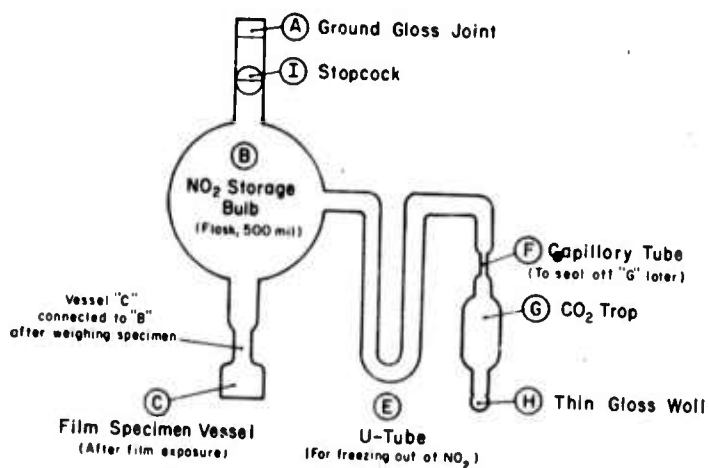

Figure 9. Arrangement for polymer films on glass slides.

Figure 10. Apparatus for fractionation of  $\text{CO}_2$ .

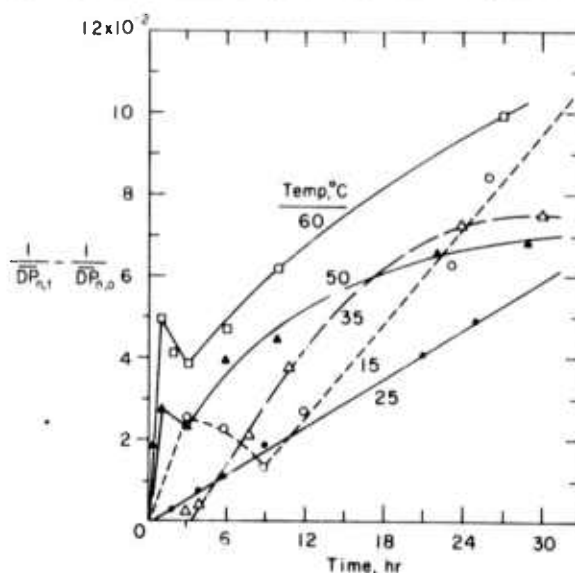

Figure 11.  $\alpha = (1/\overline{DP}_{n,t}) - (1/\overline{DP}_{n,0})$  vs exposure time of 15- $\mu$ -thick linear polyurethane films, 20 mm Hg of  $\text{NO}_2$ .

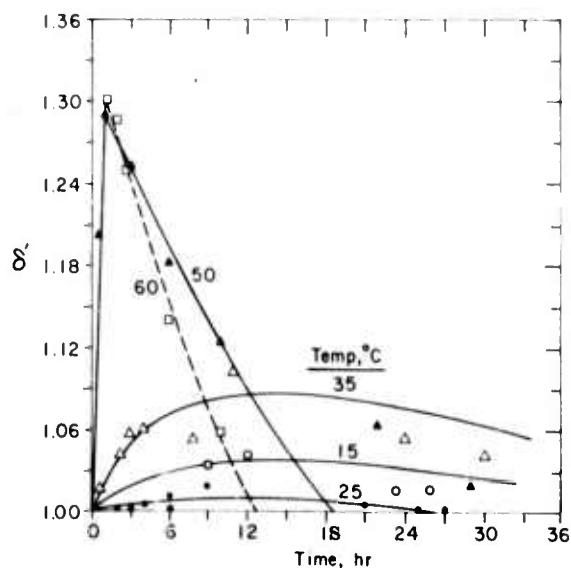

Figure 12. Cross-linking coefficient  $\delta'$  vs exposure time for 15- $\mu$ -thick linear polyurethane, 20 mm Hg of  $\text{NO}_2$ .

by exposing films of different thickness. The rate constants for chain scission as a function of film thickness are shown in Figure 13; the reaction for a film of only 10  $\mu$  thickness is still diffusion-controlled. The energy of activation for the chain scission process is relatively small (17 kcal/m), in agreement with such diffusion control. At the same time chain scission takes place,  $\text{CO}_2$  is evolved from the polymer (Fig. 14). The energy of activation for  $\text{CO}_2$  evolution is only 3.9 kcal/m, also indicating diffusion control.

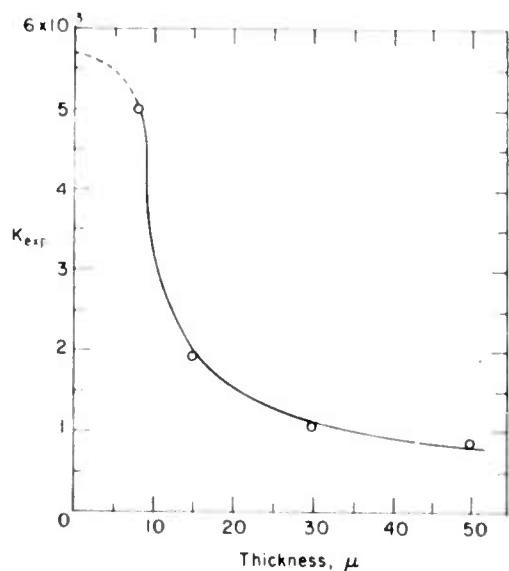

Figure 13. Rate constant for chain scission as a function of film thickness, 20 mm Hg of  $\text{NO}_2$ , 25°C.

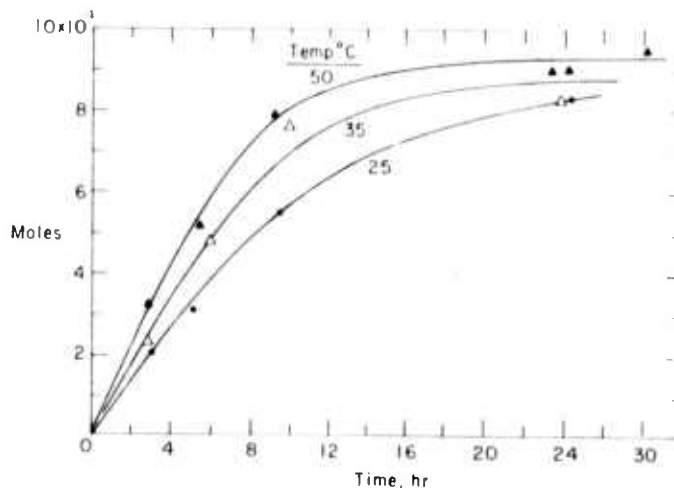

Figure 14. Production of  $\text{CO}_2$  as a function of exposure time, 20 mm Hg of  $\text{NO}_2$ .

The IR spectra of the polymer show significant changes on exposure to  $\text{NO}_2$ . Absorbance at  $3 \mu$ , for instance, changes quite appreciably with time, following a first order law with an energy of activation of 4.4 kcal/m. Actually the IR bands due to the urethane linkage ( $-\text{NH}-\text{CO}_2-$ ) at 3, 5.9 and  $6.5 \mu$  disappear gradually due to chain scission, while the absorption band at  $8.8 \mu$  increases due to the formation of nitro and nitroso groups along the backbone of the polymer.

Thus, polyurethane suffers chain scission and cross-linking on exposure to  $\text{NO}_2$  near room temperature. The cross-links are eventually scissioned again, and the initially soluble polymer passes from an insoluble to a soluble condition. At the same time, nitro and nitroso groups are incorporated along the polymer backbone on exposure, and carbon dioxide and small amounts of other unidentified small molecular weight compounds are produced. For calculations of the kinetics and mechanisms of this degradation process reference may be made to the published paper.<sup>3,4,7</sup>

The degradation reactions described above are the underlying reasons for the change in the mechanical (tensile strength) and rheological properties of the polymer during exposure to  $\text{NO}_2$ .

## STIFFNESS TESTERS

### Static apparatus

The static "stiffness" tester is shown in Figure 15. The essential principle of the apparatus is as follows. A small strip of polymer is bent (cantilever) a definite amount. The force needed to accomplish this is measured and the changes in this force due to environmental effects are recorded as a function of time. Simultaneously, the sample experiences a certain amount of permanent set. These measurements are carried out as a function of temperature, pollutant concentration and time. The "stiffness" of the polymer (Young's modulus) can be deduced from such experiments. The apparatus is contained in a glass jacket, part of which can be removed for insertion of new samples. This container is thermostated to better than  $\pm 1^\circ\text{C}$ . It has a gas inlet and outlet to provide the desired atmospheric environment. A thermocouple is located near the test sample which is clamped

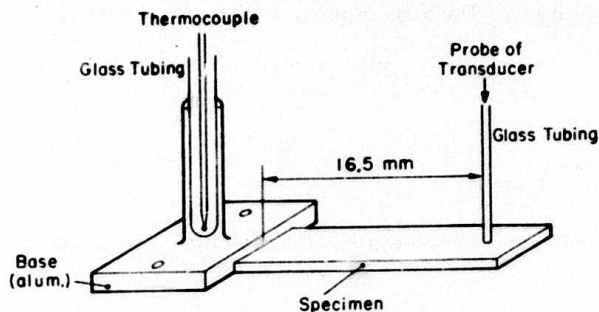

Figure 15. Static "stiffness" tester.

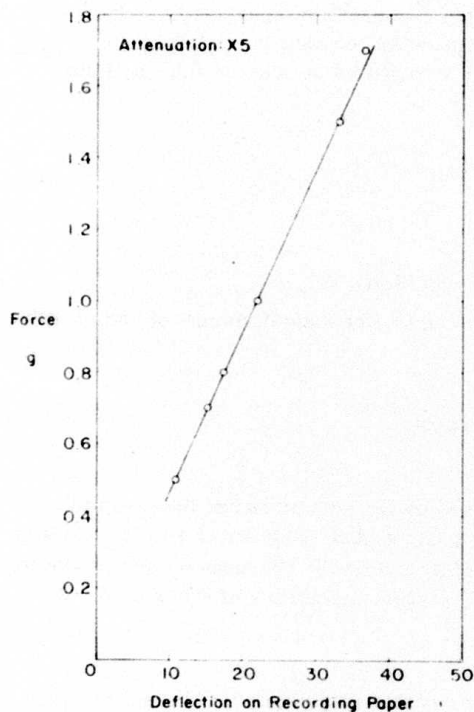

Figure 16. Calibration of transducer; force vs scale divisions.

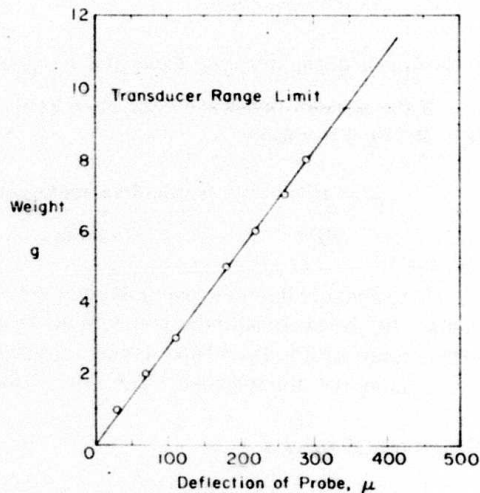

Figure 17. Calibration of transducer; weight vs movement of glass probe.

tightly at one end. A Statham Transducer (No. G10B-0.3-350) is used to measure the force applied to the specimen via a rigid glass tube (~ 3 g) and also the bending distance. The transducer is connected to a Sanborn Recorder (Model 150).

The mode of operation of the instrument is as follows. The transducer is moved vertically downward by a special device employing a micrometer screw. In the present experiments, this movement amounts to 0.5 mm (the micrometer screw can be read to within  $\pm 0.005$  mm). This movement is distributed between bending of the polymer sample and movement of the transducer probe in an upward direction. The transducer is calibrated in terms of force (grams vs scale divisions) and also in terms of actual movement at the point of contact between the probe and glass tube as a function of force. The calibrations result in linear relations (see Fig. 16 and 17). The following distances are involved:

Distance of transducer = Distance of probe + Distance of sample

$$A = B + C$$

Hence,

$$C = A - B \text{ (cm).}$$

"Stiffness"  $E$  (Young's modulus) can be evaluated as follows. For a cantilever beam one has

$$E = \frac{ML}{3I\lambda} \quad (3)$$

Here,  $M = FL$  is the bending moment ( $F$  = applied force,  $L$  = length of specimen),  $I = BD^3/12$  is the moment of inertia, and  $B$  and  $D$  are the width and thickness of the sample, respectively.  $\alpha_{\text{radians}} = \lambda/L$  (the arc is taken here as a straight line ( $\lambda$ ) which is justified because of the small amount of bending). Hence,

$$E = \frac{4FL^2}{BD^3 \alpha_{\text{radians}}} \text{ kg/cm}^2 \quad (4)$$

if the linear dimensions are measured in cm and the force in kg.

If the moment is always expressed as that pertaining to 100 scale divisions on the recorder (i.e.  $M'$ ) eq 4 becomes

$$E = \frac{4L}{BD^3} \times \frac{M' \times (\text{scale divisions recorded})}{100 \alpha_{\text{radians}}} \text{ kg/cm}^2. \quad (5)$$

It is conceivable that one source of error is caused by the pointed end of the glass tube contacting the specimen; the pressure at the point of contact is of the order of  $1 \text{ kg/cm}^2$ . However, experiments with a glass tube having a rounded end gave practically the same results as the experiments using the pointed tube. The initial load on the sample was always of the order of 10 g.

### Experimental results

Table I gives dimensional details of the polymer samples investigated. All samples show a permanent set after bending. "Stiffness"  $E$  is plotted as a function of temperature in Figures 18 and 19. Points drawn as open circles have been measured at  $t = 0$ , i.e. immediately after bending the sample, which takes 4 to 5 seconds; solid circles represent measurements after five minutes of bending. All curves except for those in Figure 18k (polyurethane) are characterized by a rapid increase in "stiffness" over a definite range of low temperatures. This increase indicates that the material becomes quite brittle and would also be easily abraded during use.

The best of the materials investigated from the point of view of "stiffness" was Goodrich 45016-3, closely followed by Du Pont EPDM compound 5109D-4420 (this does not indicate anything concerning characteristics in deleterious environments). These samples started to increase rapidly in stiffness only at temperatures around  $-40^\circ$  and  $-30^\circ\text{C}$ , respectively. Goodyear H-369 and H-384, on the other hand, showed rapid increases around  $0^\circ$  and  $+10^\circ\text{C}$ , respectively. Thus, these tests screened the materials as far as "stiffness" is concerned. If samples become "stiff" (brittle) at a relatively high temperature, it is not worthwhile testing them for environmental stability.

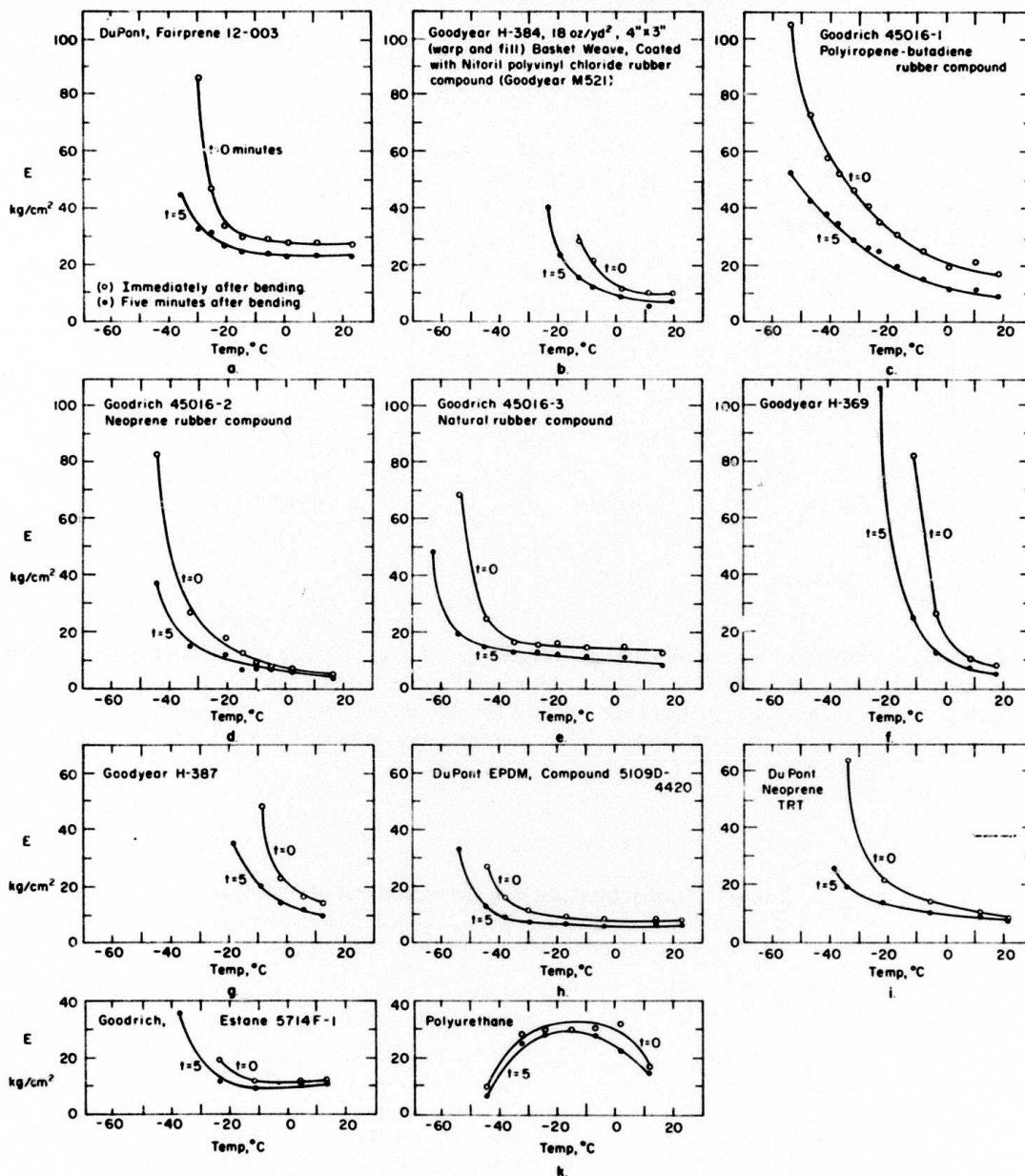

Figure 18. "Stiffness" vs temperature for various samples (static tests).

Polyurethane prepared in our laboratory showed characteristics different from those of the commercial materials (see Fig. 18k). The curves are similar to those obtained for tensile strength as a function of temperature except the maxima are shifted from about +10°C for tensile strength (compare Fig. 6) to about -10° to -20°C for the "stiffness" values.

Figure 20 shows the effect of ozone (~ 500 ppm) on Goodrich natural rubber compound 45016-3. As soon as the container was filled with air containing O<sub>3</sub> the "stiffness" rose, eventually reaching a plateau. The surface of the sample showed a grayish appearance after exposure. (For production of ozone see p. 20.)

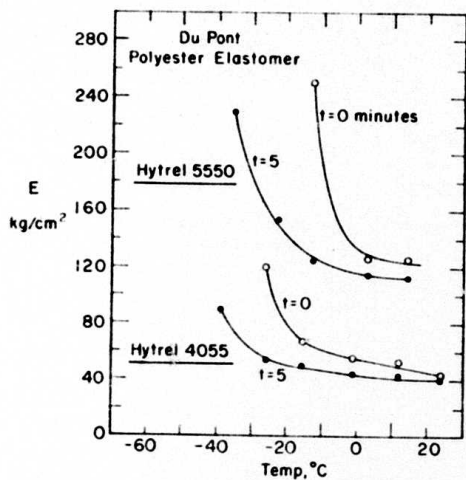

Figure 19. "Stiffness" vs temperature for Du Pont Hytel 4055 and 5550 (static tests). Measurements made immediately after bending ( $\circ$ ) and 5 minutes after bending ( $\bullet$ ).

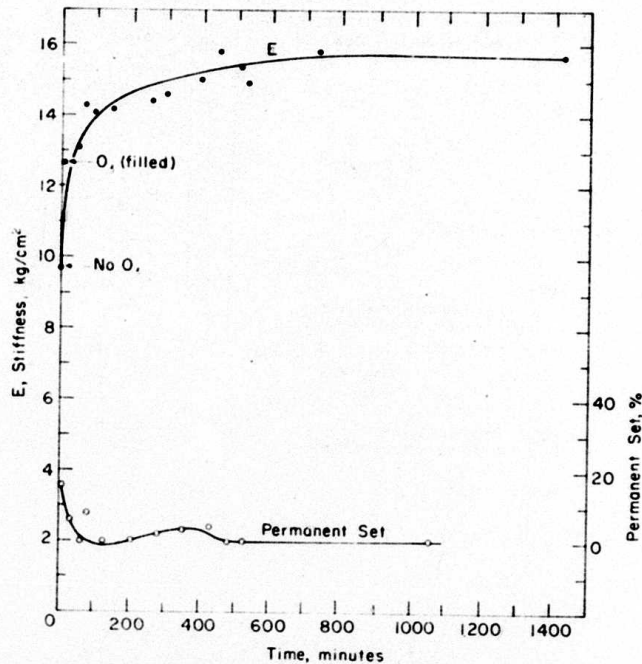

Figure 20. Effect of ozone on Goodrich natural rubber compound 45016-3, 25°C (static,  $L = 1.70$  cm,  $B = 1.03$  cm,  $D = 0.1862$  cm,  $O_3$  about 500 ppm). "Stiffness" measured five minutes after bending.

Table I. Dimensions and % of permanent set of samples.

$L$ , the distance between the point of clamping and the point of contact of the glass tube, = 1.65 cm for all samples.

Name	Width (cm)	Thickness (cm)	Permanent set (avg. %)
Du Pont Fairprene	1.05	0.161	12
Goodyear H-384	1.10	0.221	16
Goodrich 45016-1	1.08	0.172	13
Goodrich 45016-2	1.06	0.185	25
Goodrich 45016-3	1.02	0.186	13
Goodyear H-369	1.06	0.183	21
Goodyear H-387	1.02	0.221	17
Du Pont EPDM5109D-4420	1.00	0.231	27
Du Pont Neoprene	1.07	0.198	10
Goodrich Estane 5714F1	0.99	0.206	14
Linear polyurethane	1.00	0.042	17

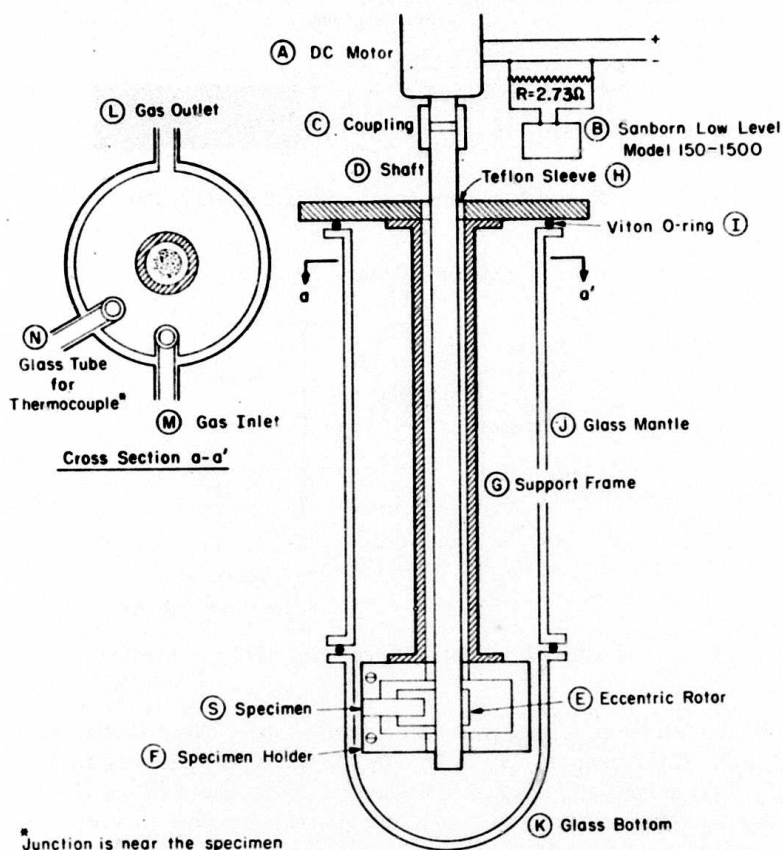

Figure 21. Dynamic "stiffness" tester.

#### Dynamic "stiffness" tester

The dynamic "stiffness" testing instrument is shown in Figure 21. It consists essentially of an eccentric rotor (E) made of Teflon, which periodically bends a strip of polymer (S) as it rotates. The rotor and sample are housed in a glass container (J); the rotor arrangement hangs in this container from an aluminum plate serving as a lid; gas tightness is obtained by Viton O-rings (I) between the flange of the glass container and the metal lid, which are pressed together by a metal collar and screws. The glass container has a gas inlet (M) and outlet (L) and also a tube reaching down inside the container so that a thermocouple can be located near the specimen. The lower part of the glass container can be removed so that the specimen can easily be replaced by another one. The shaft (D) carrying the rotor (E) is rotated by a d-c motor;\* this shaft runs in Teflon sleeves (H). The whole instrument is thermostated in an air bath to  $+1.0^{\circ}\text{C}$ ; only the motor is located outside this bath at room temperature. Any desired gas "atmosphere" can be supplied, e.g.  $\text{O}_3$  plus air,  $\text{NO}_2$  plus air, etc.

A constant d-c voltage is maintained on the motor by a constant voltage supply unit (Harrison Laboratories Inc., 0-18 v, 0-1.8 amps). The current from the source is kept constant by a Sola transformer. The speed of rotation remains constant for any one applied voltage (800 to 850 rpm

\* Globe Industries Inc., Dayton, Ohio, nominal operating voltage 27 v; the motor has a gear arrangement.

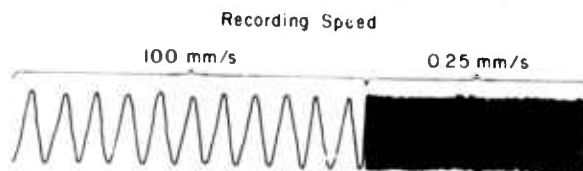

Figure 22. Recording trace of dynamic tester.

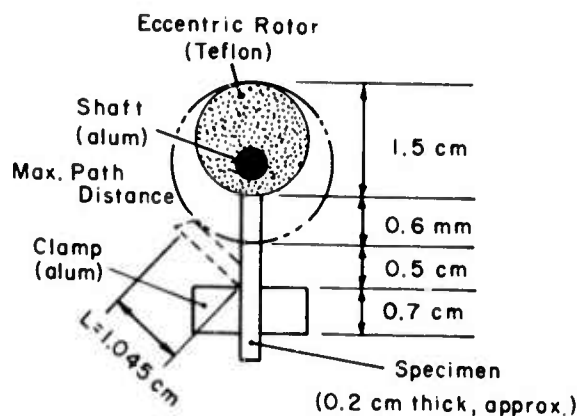

Figure 23. Details of eccentric rotor and sample.

for 15, 550 to 580 rpm for 12 v, measured with a stroboscope). However, the current changes with the applied load. This change in current (in effect in watts) is taken as a measure of changing "stiffness." This is done as indicated in Figure 21: a resistance ( $R = 2.73 \Omega$ ) is inserted in parallel with the circuit leading to the motor, and the voltage across this resistance is measured with a Sanborn recorder (Model 150). The voltage is about 10 to 20 mv.

A copy of an actual recording trace (Fig. 22) illustrates very clearly the periodic bending of the specimen. The relative rotor and sample positions are indicated in Figure 23.

The "stiffness" of a polymer specimen can be evaluated as follows. Young's modulus  $E$  is given for maximal bending by (compare eq 3)

$$E = \frac{4L^3 F_{\max}}{\lambda_{\max} B D^3} \text{ kg/cm}^2 \quad (6)$$

where  $L$ ,  $B$  and  $D$  are the length, width and thickness of the sample in cm,  $F$  is the force for maximum bending in kg,  $\lambda_{\max}$  is the corresponding bending arc in cm taken as a straight line (eccentricity of rotor 0.6 mm).  $\lambda_{\max}$  is an apparatus constant. Further,

$$F_{\max} \left( \frac{dS}{dt} \right)_{s_{\max}} = \frac{E B D^3 \lambda_{\max}}{4L^3} \left( \frac{dS}{dt} \right)_{s_{\max}} \quad (7)$$

Here  $(dS/dt)_{s_{\max}}$  is the linear rate of bending at very near maximal bending. Equation 7 can be written

$$(\text{watt})_{\max} = \frac{E B D^3 \lambda_{\max}}{4L^3} \left( \frac{dS}{dt} \right)_{s_{\max}} \quad (8)$$

Hence

$$E \left( \frac{dS}{dt} \right)_{s_{\max}} = \frac{4L^3 (\text{watt})_{\max}}{\lambda_{\max} B D^3} \quad (9)$$

but  $\lambda_{\max} = L \times \alpha_{\text{radians}}$

and

$\alpha_{\text{radians}} = \text{constant}$ .

Finally

$$\text{measure of "stiffness"} = E \left( \frac{dS}{dt} \right)_{s_{\max}} \alpha_{\text{radians}} = \frac{4L^2 (\text{watt})_{\max}}{B D^3} \quad (10)$$

As 10.2 watts = 1 kg-cm/sec, eq 10 can be expressed as

$$E' = E \left( \frac{dS}{dt} \right)_{s_{\max}} \alpha_{\text{radians}} = \frac{4L^2 P}{B D^3} \text{ kg/cm sec}$$

where  $E'$  is a measure of "stiffness" of the sample at time  $t$  of the experiment, and  $P$  is the power used at maximum bending in kg-cm/sec at exposure time  $t$ ; all lengths are expressed in cm.

$E'$  has been plotted versus time of exposure for various samples for a number of temperatures in the presence of air, and air plus ozone in Figure 24. Watts were experimentally obtained as follows:

$$\text{watt} = iv = \frac{(\text{maximum height of recording trace in mm} \times 2) \times 10^{-3} v}{2.73 \Omega} \times \text{voltage applied to motor.}$$

Here  $v$  and  $i$  are the voltage applied to the motor and its current (see recording trace, Fig. 22). The height of the recording trace is measured 40 seconds before and 40 seconds after the time for  $E'$  at time  $t$ . The average is taken and standard deviations are calculated (indicated in the various figures). Table II gives the dimensions of the samples used for the tests; the corresponding temperatures and the applied voltages are also given. The polymer best suited for checking the proper functioning of the apparatus is Goodrich Natural Rubber Compound 45016-3 (see Table II). This elastomer is very sensitive to small amounts of ozone in the air, and the response of the apparatus to changes in stiffness can therefore be properly tested with it.  $E'$  seems to depend also on the speed of rotation as is shown below:

Sample	rpm	$E'$ (kg/cm-sec)*
11	800-850	229
15	550-580	159

\* Measured at 20% deterioration.

## DEGRADATION OF POLYMERS AT LOW TEMPERATURES

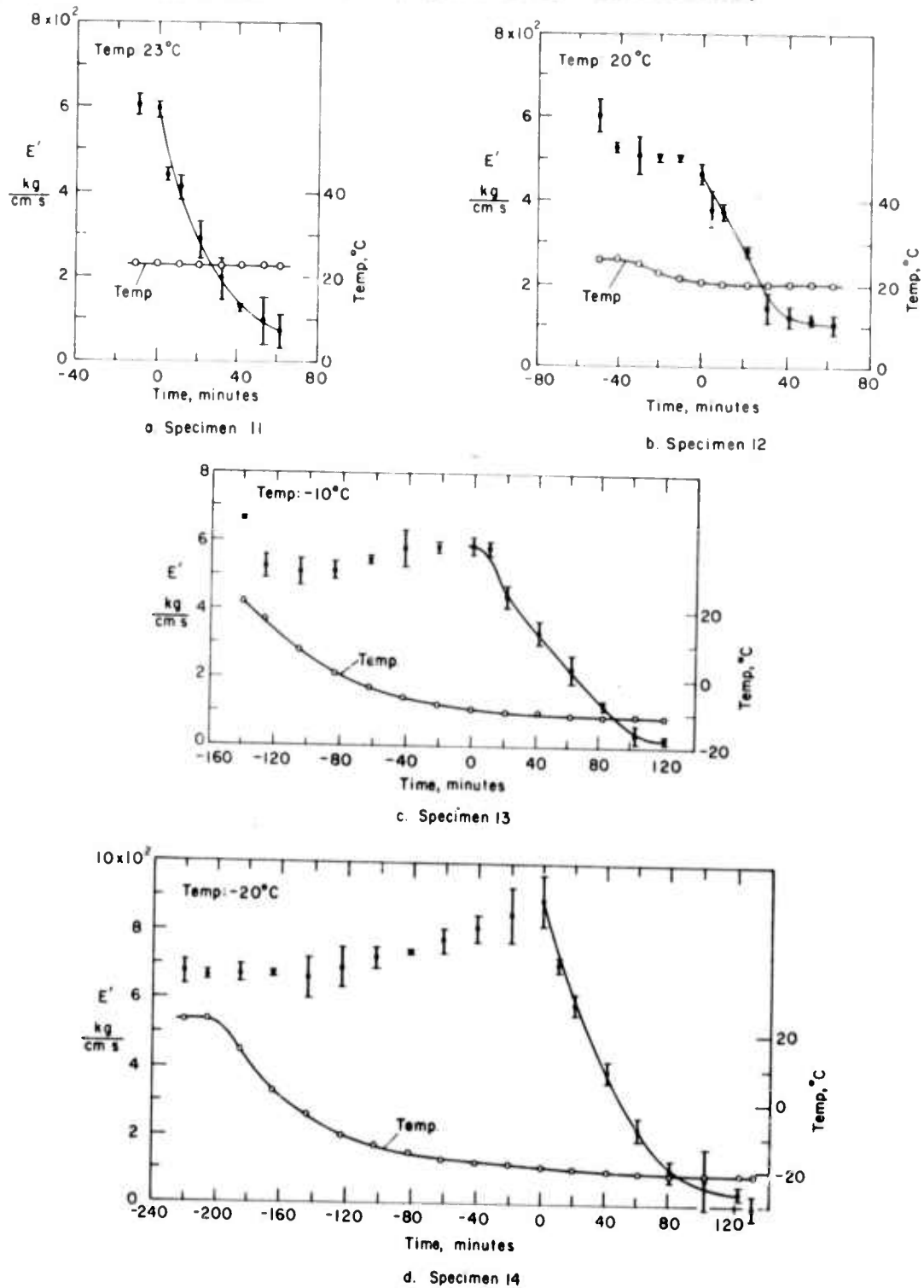

Figure 24. Natural rubber compound (Goodrich 45016-3) specimens exposed to ozonized air ( $O_3$  about 59 ppm) in dynamic tester at different temperatures. Negative times are periods before exposure to ozone;  $O_3$  introduced at  $t = 0$ ; x = points derived from heights of tracings with standard deviations. o indicates temperatures during experiment.

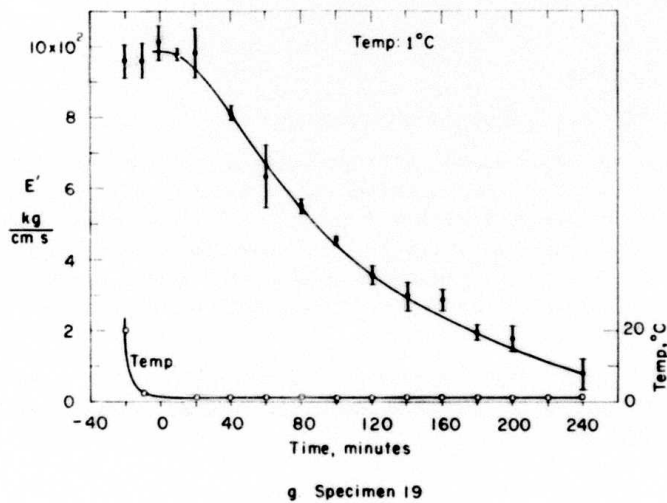
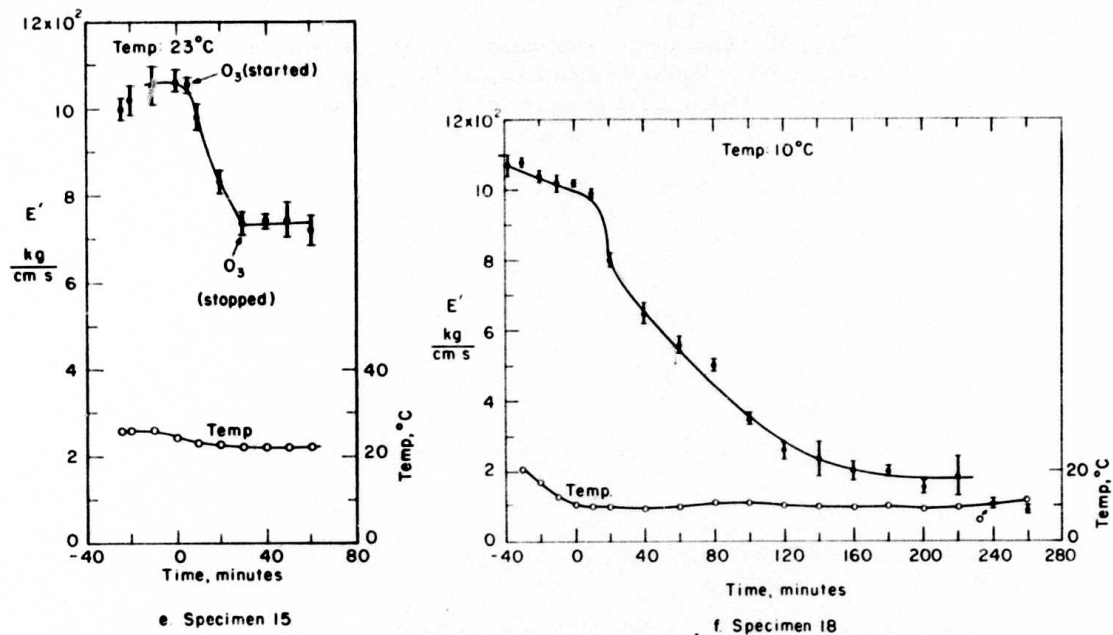

Figure 24 (cont'd).

**Table II. Dimensions, temperatures and applied voltages for specimens of Goodrich Natural Rubber Compound 45016-3 tested in the dynamic "stiffness" tester.**

$L = 1.045$  cm in all cases.

Specimen no.	Width, $B$ (cm)	Thickness, $D$ (cm)	Temp ( $^{\circ}\text{C}$ )	Applied voltage (v)
11	1.25	0.1857	23	15.0
12	1.23	0.1829	20	15.0
13	1.27	0.1824	-10	15.0
14	1.32	0.1850	-20	15.0
15	1.39	0.1877	23	11.8
18	1.47	0.1872	10	15.1
19	1.47	0.1851	1	15.15
	$\pm 0.01$	$\pm 0.0005$	$\pm 1$	$\pm 0.1$

The actual test results for all samples are given in Table III. Speeds of rotation decrease by about 10% when a load is applied.

Ozone ( $\text{O}_3$ ) was generated by irradiating air with UV light. Other gases, such as  $\text{NO}_2$ ,  $\text{SO}_2$  etc., can, in principle, also be added, but the project time was too limited. The ozone generator is manufactured by Ozone Research and Equipment Corporation (OREC, Model 03V1-0). This apparatus has an ammeter and a flow meter (readings for the experiments were 0.15 and 15 amp, i.e.  $444 \text{ cm}^3/\text{min}$ , respectively). The ozone concentration was 59 ppm based on chemical analysis carried out for another research project.

$E'$  values for 50% deterioration (decrease of initial  $E'$  by  $1/2$ ) are given below.

Testing temperature ( $^{\circ}\text{C}$ )	23	20	10	1	-10	-20
$E'_{1/2}$ (kg/cm-sec) (relative scale)	136.9	123.4	70.2	77.8	74.4	147.9

The  $E'_{1/2}$  values pass through a minimum with temperature.

Samples crack on exposure to ozone. At temperatures of  $-10^{\circ}$  and  $-20^{\circ}\text{C}$  the crack always starts at the edge where the specimen is clamped. At temperatures of  $1^{\circ}$ ,  $10^{\circ}$ ,  $20^{\circ}$  and  $23^{\circ}\text{C}$  the crack spreads from this location to a distance of about 5 mm from this edge. A sample tested at  $1^{\circ}\text{C}$  showed a large crack at the edge of the clamp and some cracks in the neighborhood. Generally, the onset of cracking at the edge of the clamp manifested itself at once in a sudden decrease in  $E'$ . As soon as ozone was removed further deterioration of the sample, i.e. decrease in  $E'$ , ceased (see for example Fig. 24e).

Du Pont EPDM compound 5109D-4420 proved remarkably stable in the presence of ozone ( $\sim 59$  ppm) at  $26^{\circ}\text{C}$  and 730 rpm; no detectable change in  $E'$  values could be observed during an exposure of 1231 minutes' duration.

**Table III. Natural Rubber Compound (Goodrich 45016-3) tested with dynamic instrument in presence of ozonized air ( $O_3$  about 59 ppm) at various temperatures.**

 Negative times are times before introduction of  $O_3$ ;  $O_3$  introduced at  $t = 0$ ; for dimensions of samples and applied voltages, see Table II; length of all samples 1.045 cm.

Time (min.)	Power (kg cm/sec)	$10^{-2} \times E'$ (kg/cm sec)	Time (min.)	Power (kg cm/sec)	$10^{-2} \times E'$ (kg/cm sec)
<b>Sample 11, 23°C</b>			<b>Sample 14, -20°C (cont'd)</b>		
- 5	1.11	6.06 ± 0.24	41	0.76	3.97 ± 0.30
0	1.09	5.95 ± 0.18	61	0.43	2.25 ± 0.33
5	0.85	4.40 ± 0.17	102	0.20	1.04 ± 0.35
11	0.75	4.10 ± 0.31	122	0.14	0.73 ± 0.83
21	0.53	2.89 ± 0.43		0.08	0.42 ± 0.18
32	0.37	2.02 ± 0.49	<b>Sample 15, 23°C</b>		
42	0.24	1.31 ± 0.12	- 26	2.10	10.00 ± 0.27
53	0.18	0.98 ± 0.55	- 20	2.15	10.22 ± 0.35
61	0.14	0.77 ± 0.41	- 10	2.22	10.57 ± 0.43
<b>Sample 12, 20°C</b>			0	2.24	10.66 ± 0.28
- 50	1.04	6.04 ± 0.39	5	2.22	10.53 ± 0.21
- 41	0.91	5.29 ± 0.07	10	2.06	9.80 ± 0.29
- 30	0.88	5.11 ± 0.46	20	1.74	8.28 ± 0.23
- 20	0.87	5.06 ± 0.07	30	1.54	7.33 ± 0.27
- 10	0.87	5.06 ± 0.07	$O_3$ removed		
0	0.81	4.68 ± 0.26	40	1.57	7.47 ± 0.11
5	0.66	3.83 ± 0.43	50	1.57	7.47 ± 0.40
10	0.65	3.78 ± 0.20	60	1.51	7.18 ± 0.33
21	0.48	2.79 ± 0.13	<b>Sample 18, 10°C</b>		
31	0.25	1.45 ± 0.38	- 38	2.36	10.68 ± 0.33
41	0.21	1.22 ± 0.26	- 30	2.39	10.82 ± 0.13
52	0.21	1.22 ± 0.13	- 20	2.30	10.40 ± 0.18
62	0.18	1.05 ± 0.26	- 10	2.25	10.18 ± 0.23
<b>Sample 13, -10°C</b>			0	2.25	10.18 ± 0.11
-140	1.27	6.64 ± 0.06	10	2.20	9.93 ± 0.15
-126	1.01	5.27 ± 0.35	20	1.77	8.01 ± 0.20
-105	0.98	5.12 ± 0.41	40	1.43	6.48 ± 0.31
- 84	0.99	5.17 ± 0.24	60	1.24	5.61 ± 0.24
- 63	1.04	5.43 ± 0.06	80	1.11	5.03 ± 0.16
- 42	1.11	5.79 ± 0.53	100	0.77	3.48 ± 0.16
- 21	1.12	5.85 ± 0.18	120	0.63	2.58 ± 0.25
0	1.13	5.90 ± 0.23	140	0.52	2.35 ± 0.50
10	1.03	5.81 ± 0.19	160	0.44	1.99 ± 0.27
21	0.84	4.39 ± 0.29	180	0.44	1.99 ± 0.13
41	0.64	3.34 ± 0.35	200	0.34	1.54 ± 0.19
62	0.44	2.30 ± 0.41	220	0.41	1.85 ± 0.57
82	0.24	1.25 ± 0.11	240	0.24	1.08 ± 0.14
103	0.08	0.42 ± 0.24	260	0.20	0.91 ± 0.12
121	0.05	0.26 ± 0.10	<b>Sample 19, 1°C</b>		
<b>Sample 14, -20°C</b>			- 20	2.05	9.59 ± 0.43
-220	1.29	6.74 ± 0.35	- 10	2.05	9.59 ± 0.51
-206	1.28	6.69 ± 0.15	0	2.16	10.10 ± 0.40
-185	1.28	6.69 ± 0.28	10	2.08	9.74 ± 0.15
-165	1.29	6.74 ± 0.06	20	2.10	9.82 ± 0.70
-144	1.27	6.63 ± 0.54	40	1.73	8.09 ± 0.19
-123	1.33	6.95 ± 0.62	60	1.35	6.31 ± 0.91
-103	1.39	7.26 ± 0.30	80	1.18	5.51 ± 0.19
- 82	1.42	7.42 ± 0.07	100	0.97	4.54 ± 0.11
- 62	1.48	7.73 ± 0.33	120	0.76	3.55 ± 0.24
- 41	1.55	8.10 ± 0.39	140	0.63	2.94 ± 0.42
- 21	1.63	8.52 ± 0.79	160	0.61	2.85 ± 0.31
0	1.71	8.94 ± 0.73	180	0.41	1.92 ± 0.19
10	1.35	7.07 ± 0.22	200	0.37	1.73 ± 0.33
20	1.13	5.90 ± 0.28	240	0.16	0.75 ± 0.46

## SUMMARY

1. A tensile strength apparatus constructed for measuring the ultimate strength of polymers as a function of temperature, environmental conditions (i.e. air plus NO<sub>2</sub>, etc., or NO<sub>2</sub> alone), exposure time and pollutant concentration was found to work satisfactorily.

2. The tensile strength of a specially prepared linear polyurethane sample was affected appreciably by NO<sub>2</sub> alone or NO<sub>2</sub> plus air. Tensile strength decreases with exposure time; it passes through a maximum near +10°C when plotted as a function of temperature and exposure time. This maximum shifts slightly to higher temperatures with increased exposure time. Tensile strength as a function of exposure time for constant temperature and constant pollutant concentration obeys a rate law as follows:  $-dS/dt = k(S - S_f)$  where  $S$  and  $S_f$  are the tensile strengths at time  $t$  and  $t = \infty$ , and  $k$  is a rate constant (integrated:  $\ln(S_0 - S_f)/(S - S_f) = kt$ , where  $S_0$  is the tensile strength at  $t = 0$ ). The Arrhenius plot for the rate constants also passes through a maximum near +10°C.

3. Exposure of thin polyurethane films to NO<sub>2</sub> shows that chain scission, cross-linking, evolution of CO<sub>2</sub> and production of small amounts of other low molecular weight compounds take place. In addition, the infrared spectra of the polymer change during exposure due to formation of nitro and nitroso groups along the polymer backbone. These reactions are the underlying causes for the change in mechanical properties on exposure except for the changes due to change in temperature alone. The kinetics and mechanisms of these degradation reactions have been evaluated quantitatively.

4. A novel static "stiffness" tester has been constructed and shown to function properly. It allows one to measure "stiffness" (Young's modulus) of polymers (especially elastomers) as a function of temperature, exposure time to pollutants or polluted air, and pollutant concentration.

5. Results obtained with this instrument as a function of temperature permit a preliminary selection of polymeric skirting materials to be made on the basis of their mechanical properties at low temperatures. Only two of the samples supplied by industry showed satisfactory properties; their "stiffness" started to increase rapidly at -40°C and -30°C. The other samples became brittle at higher temperatures.

6. A dynamic "stiffness" tester has also been constructed and operates satisfactorily. Here again a measure of "stiffness" results as a function of temperature, exposure time to pollutants or polluted air, and pollutant concentration.

7. The instrument has been tested thoroughly with a natural rubber compound in ozonized air. This compound is sensitive to ozone and therefore is especially suitable for checking the functioning of the apparatus; the onset of cracks in the sample was clearly indicated by this instrument.

8. An EPM compound tested in this apparatus proved quite resistant to small concentrations of ozone in air over prolonged periods of time in contrast to the natural rubber compound.

9. Time did not allow tests to be completed on all the compounds supplied by industry. In addition, the accuracy of the "dynamic" stiffness tester could be improved by using a higher quality motor and power supply.

## CONCLUSION

The three apparatus which have been constructed (tensile strength and static and dynamic stiffness testers) perform satisfactorily for the investigation of mechanical and rheological properties of polymers over a wide temperature range and in various gaseous environments.

The apparatus were tested with linear polyurethane in the presence and absence of small amounts of nitrogen dioxide. The detrimental effect of this gas on the polymer, as well as the effects temperature changes have on its mechanical properties, can be determined very satisfactorily with these instruments. Similarly, the effect of ozone on elastomers can be very successfully studied, especially with the static and dynamic stiffness testers.

Further, investigation of polyurethane revealed that the changes observed in the physical properties of polyurethane on exposure to  $\text{NO}_2$  are ultimately due to chain scission, cross-linking, incorporation of nitro and nitroso groups, and evolution of  $\text{CO}_2$  and other small molecular weight compounds. An investigation of polymers thought to be suitable as skirting materials for SEV's showed that only two of the polymers remained sufficiently flexible at temperatures as low as  $-40^\circ\text{C}$ . This was established with the static stiffness tester. The dynamic stiffness tester showed that a Du Pont EPDM compound was not affected by ozone ( $\approx 59$  ppm) over long periods of time, whereas a rubber compound, as expected, suffered fast deterioration. The dynamic stiffness tester is an instrument exceptionally well suited for detecting the onset of cracking due to exposure to small concentrations of ozone. The effect of ozone is also known to be due to chain scission and cross-linking.

#### LITERATURE CITED

1. Jellinek, H.H.G. (1970) Chain scission of polymers by small concentrations (1 to 5 ppm) of sulfur dioxide and nitrogen dioxide, respectively, in presence of air and near ultra-violet radiation. *Journal Air Poll. Contr. Assoc.*, vol. 20, p. 672-674.
2. Jellinek, H.H.G. (1972) Polymer-gas reactions (air pollutants:  $\text{NO}_2$  and  $\text{SO}_2$ ) as function of pressure, UV light, temperature and morphology - A survey. Natl. Bur. Stand., Special Publ. 357, *Proc. of the 4th Res. Symp.*, Oct. 26-29, 1970, Gaithersburg, Md., p. 101-108.
3. Jellinek, H.H.G. (1973) Reactions of linear polymers with nitrogen dioxide and sulfur dioxide. *Textile Res. Journal*, vol. 43, p. 557-560.
4. Jellinek, H.H.G. and T.J.Y. Wang (1973) Reaction of nitrogen dioxide with linear polyurethane. *Journal of Polymer Science, Polymer Chemistry Edition*, vol. 11, p. 3227-3242.
5. Martin, F. (1973) Effect of  $\text{NO}_2$  on the tensile strength of a polyurethane polymer. M. S. thesis, Department of Chemistry, Clarkson College of Technology, Potsdam, New York 13676.
6. Sorensen, W.R. and T.W. Campbell (1962) *Preparative methods of polymer chemistry*. New York: Interscience Publ. Inc., p. 110.
7. Wang, T.J.Y. (1972) Polymer-gas reactions. Department of Chemistry, Clarkson College of Technology, PhD. thesis.