

AD-782 955

STREAMLINE CALCULATIONS USING THE  
XYZ POTENTIAL FLOW PROGRAM

James Gillespie, Jr.

Army Air Mobility Research and Development  
Laboratory  
Fort Eustis, Virginia

May 1974

DISTRIBUTED BY:

**NTIS**

**National Technical Information Service**  
**U. S. DEPARTMENT OF COMMERCE**  
5285 Port Royal Road, Springfield Va. 22151

DISCLAIMERS

The findings in this report are not to be construed as an official Department of the Army position unless so designated by other authorized documents.

Trade names cited in this report do not constitute an official endorsement or approval of the use of such commercial hardware or software.

DISPOSITION INSTRUCTIONS

Destroy this report when no longer needed. Do not return it to the originator.

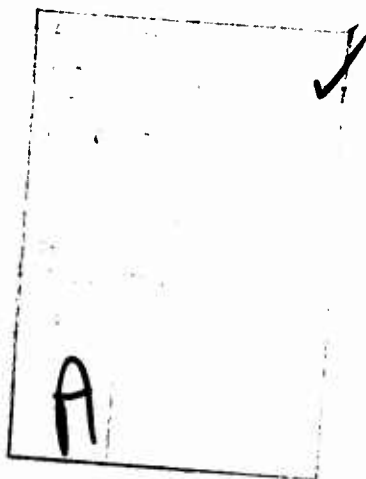

Unclassified

AD-782955

SECURITY CLASSIFICATION OF THIS PAGE (When Data Entered)

REPORT DOCUMENTATION PAGE		READ INSTRUCTIONS BEFORE COMPLETING FORM
1. REPORT NUMBER USAAMRDL-TN-16	2. GOVT ACCESSION NO.	3. RECIPIENT'S CATALOG NUMBER
4. TITLE (and Subtitle) STREAMLINE CALCULATIONS USING THE XYZ POTENTIAL FLOW PROGRAM	5. TYPE OF REPORT & PERIOD COVERED	
	6. PERFORMING ORG. REPORT NUMBER	
7. AUTHOR(s) James Gillespie, Jr.	8. CONTRACT OR GRANT NUMBER(s)	
9. PERFORMING ORGANIZATION NAME AND ADDRESS Eustis Directorate, U. S. Army Air Mobility Research and Development Laboratory Fort Eustis, Virginia 23604	10. PROGRAM ELEMENT, PROJECT, TASK AREA & WORK UNIT NUMBERS Project 1F162204AA41 House Task 74-01	
11. CONTROLLING OFFICE NAME AND ADDRESS	12. REPORT DATE May 1974	
	13. NUMBER OF PAGES 23	
14. MONITORING AGENCY NAME & ADDRESS (if different from Controlling Office)	15. SECURITY CLASS. (of this report) Unclassified	
	15a. DECLASSIFICATION/DOWNGRADING SCHEDULE	
16. DISTRIBUTION STATEMENT (of this Report) Approved for public release; distribution unlimited.		
17. DISTRIBUTION STATEMENT (of the abstract entered in Block 20, if different from Report)		
18. SUPPLEMENTARY NOTES		
19. KEY WORDS (Continue on reverse side if necessary and identify by block number) Helicopters Flow Drag reduction Fuselages		
20. ABSTRACT (Continue on reverse side if necessary and identify by block number) Potential flow and boundary layer calculations have been performed on various helicopter fuselage configurations as part of an overall program to provide an analytical method to predict and subsequently reduce parasite drag. The boundary layer calculation uses the small crossflow assumption and requires a knowledge of the streamline divergence. The present method for calculating streamline divergence is not completely satisfactory. The XYZ potential flow program, developed by the Naval Ship Research and Development Center, appeared to have a more attractive streamline divergence calculation. Streamline divergence calculations		

1

Unclassified

SECURITY CLASSIFICATION OF THIS PAGE(When Data Entered)

Block 20 - continued

using the XYZ program were validated on a cone, a sphere, and the HLH model. In addition, a potential flow calculation, using the XYZ program, was performed on a scale model of the Boeing Vertol Heavy Lift Helicopter (HLH), and the results agreed very well with wind tunnel test data. These results indicate that the XYZ potential flow program can be used to calculate the streamline divergence of advanced Army helicopter fuselage configurations.

Unclassified

SECURITY CLASSIFICATION OF THIS PAGE(When Data Entered)

## PREFACE

The analytical work was performed under House Task 74-01 at the Eustis Directorate using the XYZ potential flow computer program developed by the Naval Ship Research and Development Center (NSRDC). The cooperation of NSRDC in providing the computer program and giving advice on its use is gratefully acknowledged.

The wind tunnel test data on the HLH fuselage model was obtained under Eustis Directorate Contract DAAJ02-73-C-0052. The work was authorized under DA Project 1F162204AA41.

## TABLE OF CONTENTS

	<u>Page</u>
PREFACE .....	1
LIST OF ILLUSTRATIONS.....	4
INTRODUCTION.....	5
POTENTIAL FLOW ANALYSIS.....	6
General Discussion.....	6
Comparison of Test Data and Theory.....	8
STREAMLINE AND DIVERGENCE CALCULATION.....	14
General Discussion and Program Checkout.....	14
HLH Calculation.....	18
CONCLUSION.....	18
REFERENCES.....	21

## LIST OF ILLUSTRATIONS

<u>Figure</u>		<u>Page</u>
1	Representation of a sphere.....	7
2	Sketch of HLH configuration.....	7
3	Pressure coefficient versus axial distance on forward part of HLH model.....	9
4	Pressure coefficient versus axial distance on stub wing of HLH model.....	11
5	Pressure coefficient versus axial distance on aft pylon of HLH model.....	12
6	Pressure coefficient versus axial distance on nacelle of HLH model.....	15
7	Streamline calculation on 30° cone.....	17
8	Streamline calculation on sphere.....	17
9	Streamline calculation on HLH fuselage.....	19

## INTRODUCTION

The reduction of parasite drag offers a great potential for improving the performance of future Army helicopters. A systematic analytical and experimental program is required to improve parasite drag prediction methods, to develop drag reduction methodology, and to explore problem areas. In-house and contractual efforts in the parasite drag area have been under way at the Eustis Directorate for several years. Reference 1<sup>1</sup> describes an effort wherein analytical methods have been used to determine the potential flow field and boundary layer of a helicopter fuselage, and the results are applied to parasite drag prediction. Comparison of the analytical calculations with wind tunnel test data demonstrated the usefulness of the analytical approach to drag reduction. An overall objective of the drag reduction program is to provide an analytical capability to the engineer that is simple to use and that can produce optimized low-drag fuselage configurations.

The technical approach in Reference 1 is to determine the three-dimensional potential flow field of the helicopter fuselage and then to determine the fuselage boundary layer along streamlines using the small crossflow assumption. The small crossflow assumption, which uses an axisymmetric boundary layer analysis along streamlines with the radius replaced by the streamline divergence, is used because a general three-dimensional boundary layer analysis is not readily available. The three computer programs required to perform the flow field calculations of the fuselage are

- Potential flow
- Streamline and divergence calculation
- Boundary layer

The program described in Reference 2<sup>2</sup> has been used for calculating streamlines and divergence, but it has a number of limitations that make it difficult to use: it is restricted to nonyawed flow, it has restrictions in usable body geometry, its input is incompatible with the potential flow program, and its output is incompatible with the boundary layer program. The effort described in this report, therefore, is concerned only with finding a suitable streamline calculation program that is an integral part of the potential flow analysis and removes the limitations described above.

The XYZ potential flow computer program developed by the Naval Ship Research and Development Center (NSRDC), Caderock, Maryland, appeared to be such a program. The XYZ program<sup>3</sup> is essentially an improved version of the Douglas-Neumann program, which was used

---

<sup>1</sup>J. Gillespie, *An Investigation of the Flow Field and Drag of Helicopter Fuselage Configurations*, AHS 29th Annual Forum, May 1973.

<sup>2</sup>Fred R. DeJarnette, *Calculation of Inviscid Surface Streamlines and Heat Transfer on Shuttle Type Configurations*, NASA CR-111921, August 1971.

<sup>3</sup>Charles W. Dawson and Janet S. Dean, *The XYZ Potential Flow Program*, NSRDC Report 3892, June 1972.

in the parasite drag effort described in Reference 1. In addition to the potential flow calculation, the earlier XYZ program could determine on- and off-body streamlines. Recently, NSRDC added a streamline divergence calculation to the program which was not fully validated and required a checkout prior to general use.

After checkout of the streamline divergence calculation, the XYZ program was then used to determine the potential flow field and streamlines of a 1/12th scale model of the Boeing Vertol Heavy Lift Helicopter (HLH) fuselage. The HLH was selected for the analysis because of its current interest to the Army and the availability of pressure and flow visualization data from a wind tunnel test program. The HLH fuselage is probably one of the most complicated geometries that can be encountered, and successful modeling of the HLH fuselage demonstrated the versatility of the XYZ potential flow analysis. In subsequent sections of this report, the HLH potential flow calculation, program checkout of the divergence calculation, and HLH streamline calculations using the XYZ program are described.

## POTENTIAL FLOW ANALYSIS

### GENERAL DISCUSSION

The XYZ potential flow program requires as input the X, Y, and Z coordinates of a series of points describing a body. These points are indexed by the values of the integer variables M and N in the program (see Figure 1). A potential user of the XYZ program is referred to Reference 3, which fully describes the input quantities and theory. The body is represented in the XYZ program by a number of plane source panels that are formed from the input points. The streamline divergence calculation requires that the number of panels in the M and N intervals be even.

The XYZ program allows the user to take advantage of body symmetry. For the HLH fuselage model, 608 panels were required to represent one side of the body. This is near the maximum number of 650 panels allowed by the XYZ program. The running time of the XYZ computer program is directly dependent on the number of source panels used. The CPU time on the CDC 6600 computer, including the streamline divergence calculation, was approximately twenty-three minutes for one case.

The 1/12th scale HLH configuration and coordinate system used are shown in Figure 2. Pressure taps were located along fuselage top and bottom centerlines and along waterlines (or lines of constant Z) on the forward and rear pylons. Pressure taps on the stub wing and nacelle were located on butt lines (or lines of constant Y). The HLH test program and its results are described in Reference 4,<sup>4</sup> which is available from the Eustis Directorate.

---

<sup>4</sup>D. T. Julian, *Wind Tunnel Tests To Measure Surface Pressure Distributions on the 1/12th Scale of the Boeing Vertol Heavy Lift Helicopter (HLH)*, Boeing Report D210-10676-1, July 1973.

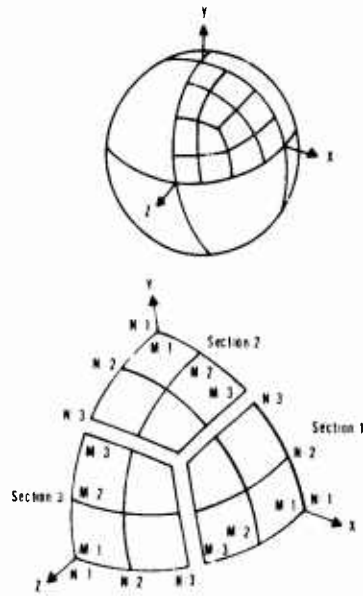

Figure 1. Representation of a sphere.

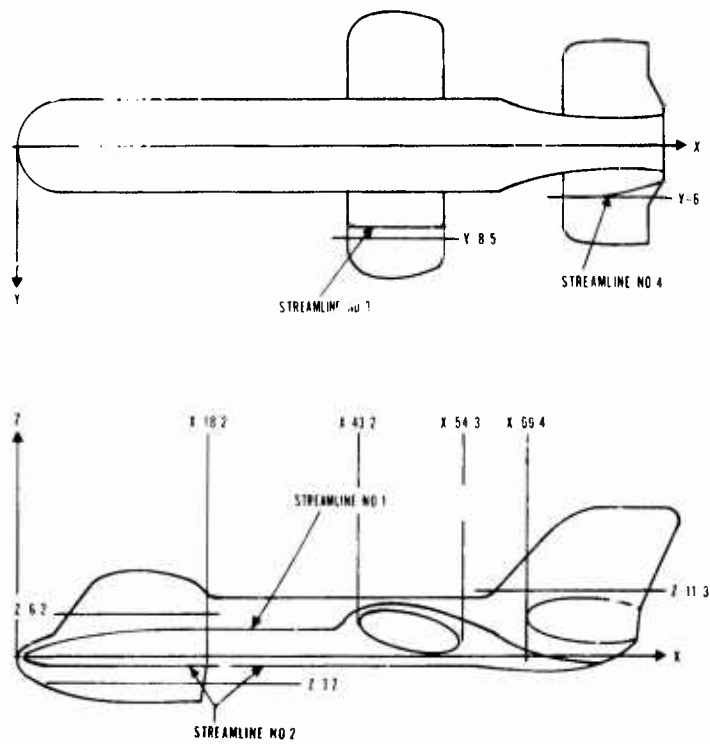

Figure 2. Sketch of HLH configuration.

## COMPARISON OF TEST DATA AND THEORY

A comparison of pressures obtained from the test program and the XYZ computer program is shown in Figure 3, where pressure coefficient has been plotted as a function of axial distance along the bottom centerline and along three waterlines on the observer cab and front pylon of the HLH at zero yaw and angle of attack. Agreement between test and theory is generally good except at the aft end of the observer cab (axial distance,  $X \approx 16$ ). The poor agreement in this area is due to the effect of a sharp corner on the observer cab. The potential flow pressure coefficient before a sharp corner approaches minus infinity. In reality, the flow field separates behind the corner and a large discrepancy exists between the potential flow solution and real flow before the sharp corner. As noted in Reference 1, this problem was encountered on the rear of the pylon of the BO-105 fuselage model.

In order to predict the pressure near a sharp corner, additional sources were placed in the flow field behind the pylon to simulate the separated flow field. This approach was successful in producing an accurate description of the pressure field prior to the sharp corner. Another approach taken to this problem is the method of Reference 5,<sup>5</sup> where flow is allowed through the panels on the rear surface of the observer cab. The boundary condition of zero normal velocity on these panels is no longer enforced, and the normal velocity is set equal to the component of free-stream velocity in the direction of the normal to the surface. For a surface perpendicular to the free-stream velocity vector, the normal velocity on the panel is equal to the free-stream velocity. The result of this calculation is shown in Figure 3(a) by the dashed line and is in good agreement with the test data. These calculations were performed on essentially the same HLH panel model.

Pressure distributions on the upper and lower surfaces of the stub wing, obtained from test data and theory, are shown in Figure 4. Agreement between test and theory is very good. Some flow separation is occurring at the rear of the wing as indicated by the nearly constant test data in this location. It should be pointed out that the XYZ program uses only source distributions and cannot represent lifting conditions. Although the fuselage is at zero angle of attack for this case, the stub wing is at a high incidence angle (over  $20^\circ$ ) and generates lift. However, since the stub wing is quite thick (approximately 30%), it does not generate high lift in the sense of a conventional airfoil. For this body and flow condition, the nonlifting XYZ program approximates the pressure distributions quite accurately. An interesting comparison can be made with the lifting program of Reference 5, where a vortex distribution has been added to the source distribution to simulate lifting conditions. This is shown by the dashed line in Figure 4 and indicates improved accuracy of this solution over the XYZ calculation.

Pressure distributions along various waterlines on the aft pylon are shown in Figure 5. Agreement between test data and theory is quite good except for the last data point in Figure 5(c),  $Z = 8.75$ , and the aft end of the upper sections on the pylon. On waterline  $Z = 8.75$ , the last data point occurs near the beginning of the pylon nacelle juncture, where flow is probably beginning to accelerate to go around the nacelle. The paneling model uses rather large panels in this area, and it is believed that a more refined paneling model would show the rise in negative pressure coefficient. The other discrepancy is due to the presence of a sharp corner on the back surface of the aft pylon.

In Figure 5(d) the pressure is also calculated using the method of Reference 5. An interesting point in this figure is the peak negative pressure coefficient indicated by the two theories. If one were to rely on the test data, this peak could not have been determined. Since pressure

---

<sup>5</sup> F. A. Woodward, F. A. Dvorak, and E. W. Geller, *A Computer Program for Three-Dimensional Lifting Bodies in Subsonic Inviscid Flow*, USAAMRDL-TR-74-18, Eustis Directorate, U. S. Army Air Mobility Research and Development Laboratory, Fort Eustis, Virginia, April 1974.

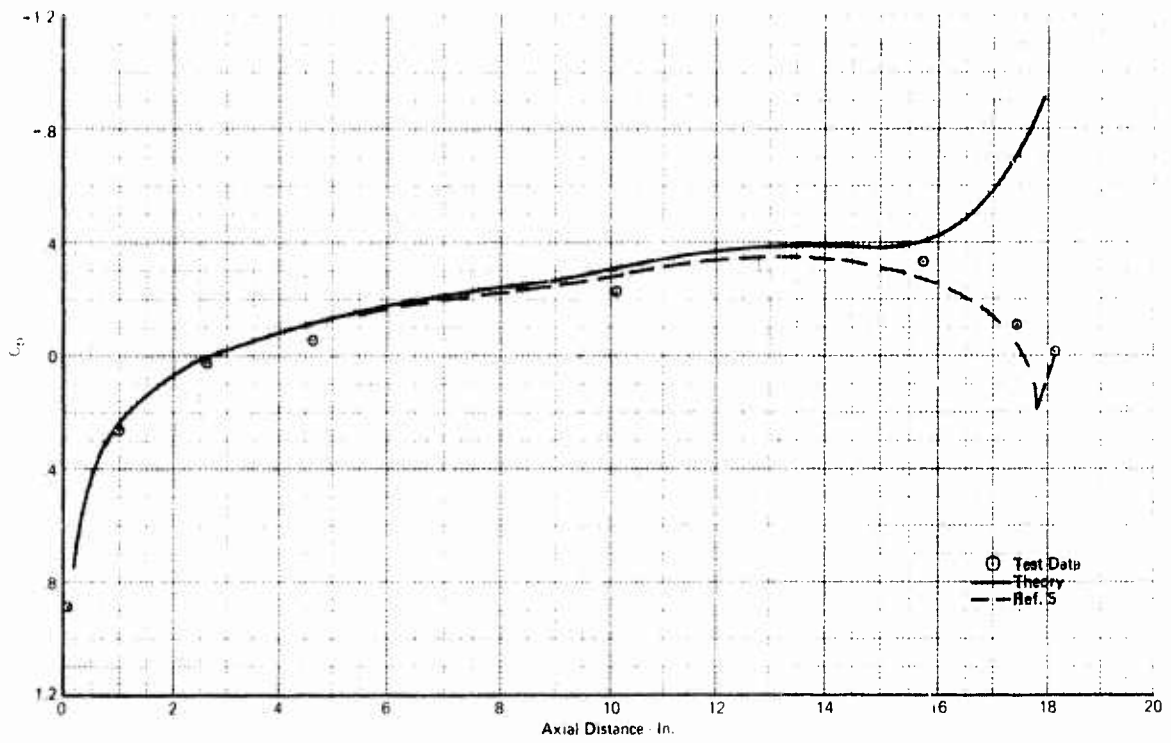

a. Bottom centerline

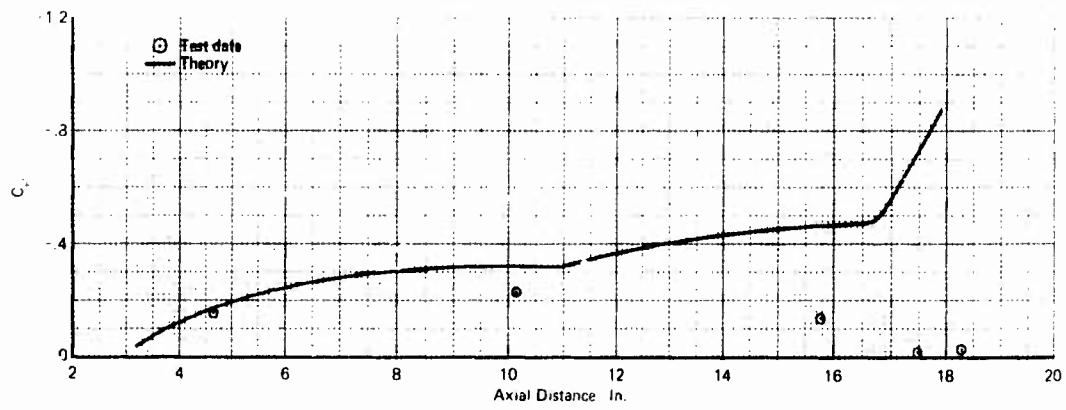

b.  $Z = -3.2$  inches

Figure 3. Pressure coefficient versus axial distance on forward part of HLH model.

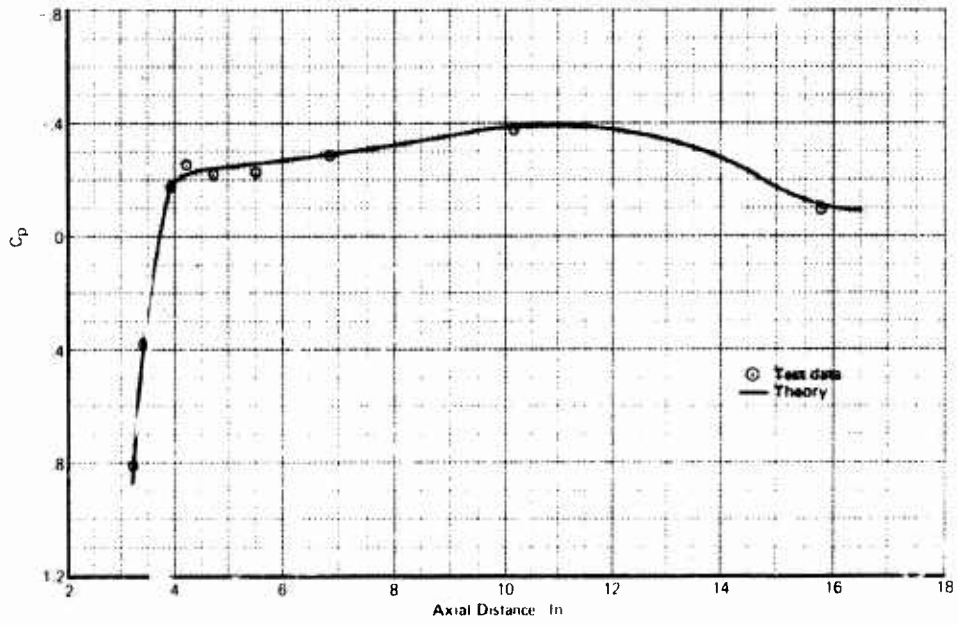

c. Z = 3.9 inches

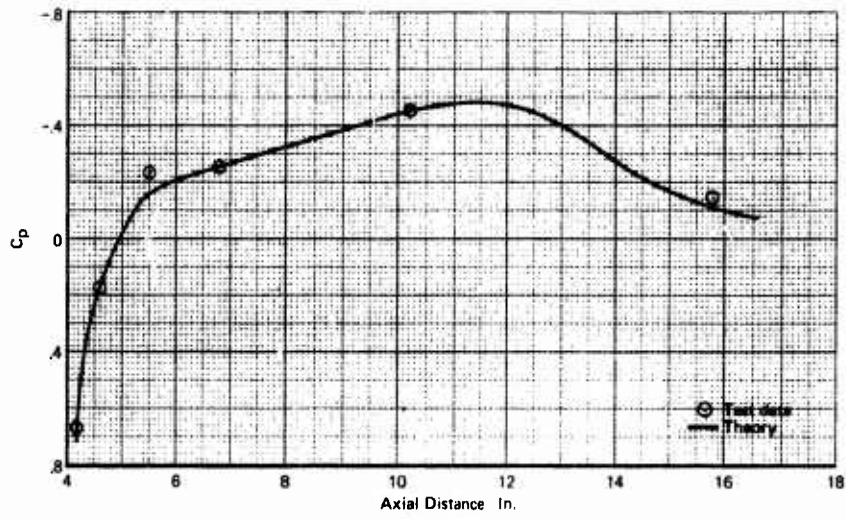

d. Z = 6.2 inches

Figure 3 - continued.

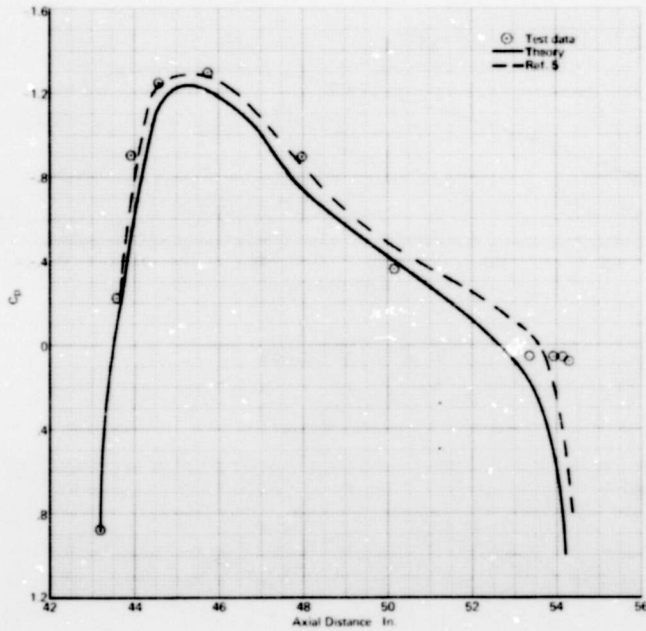

a. Upper surface,  $Y = 8.5$  inches

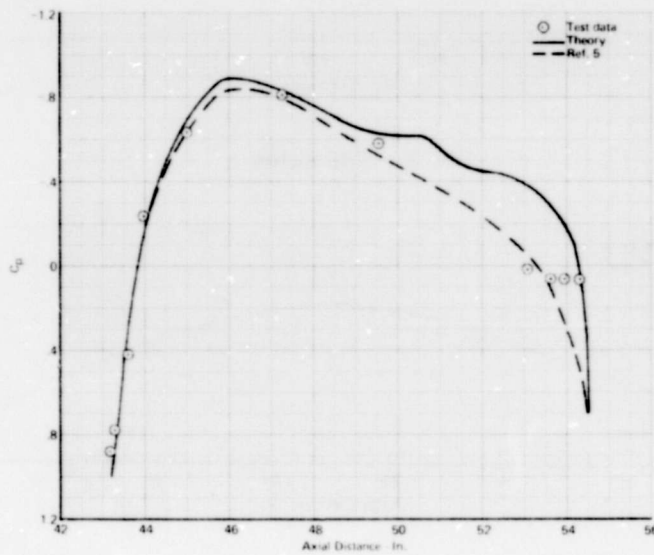

b. Lower surface,  $Y = 8.5$  inches

Figure 4. Pressure coefficient versus axial distance on stub wing of HLH model.

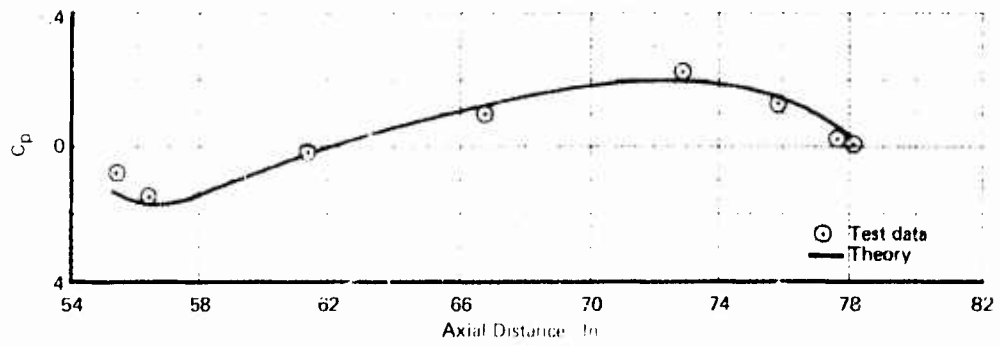

a. Z = 1.3 inches

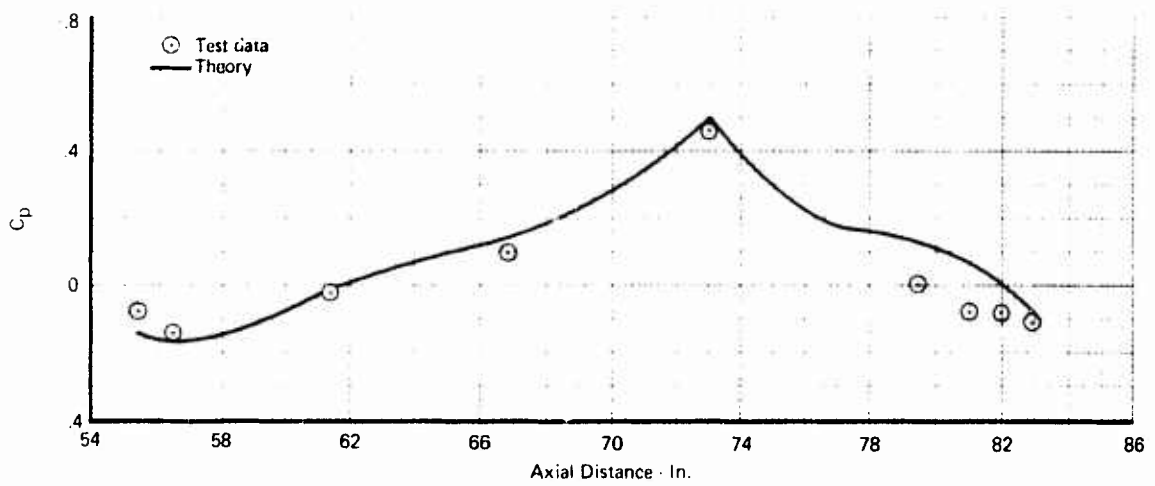

b. Z = 3.85 inches

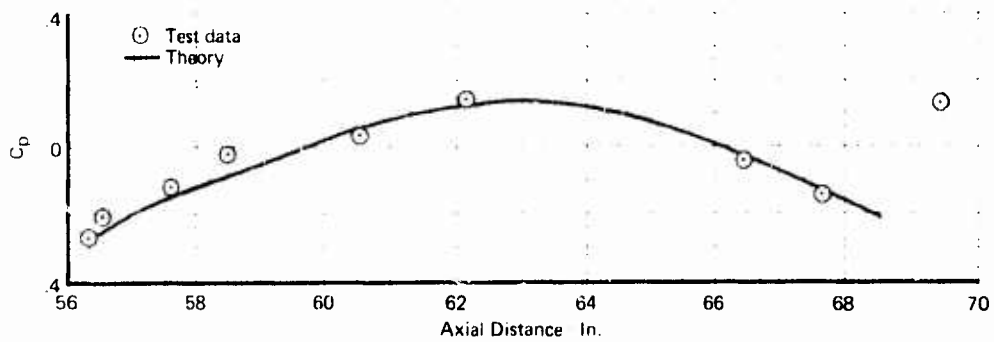

c. Z = 8.75 inches

Figure 5. Pressure coefficient versus axial distance on aft pylon of HLH model.

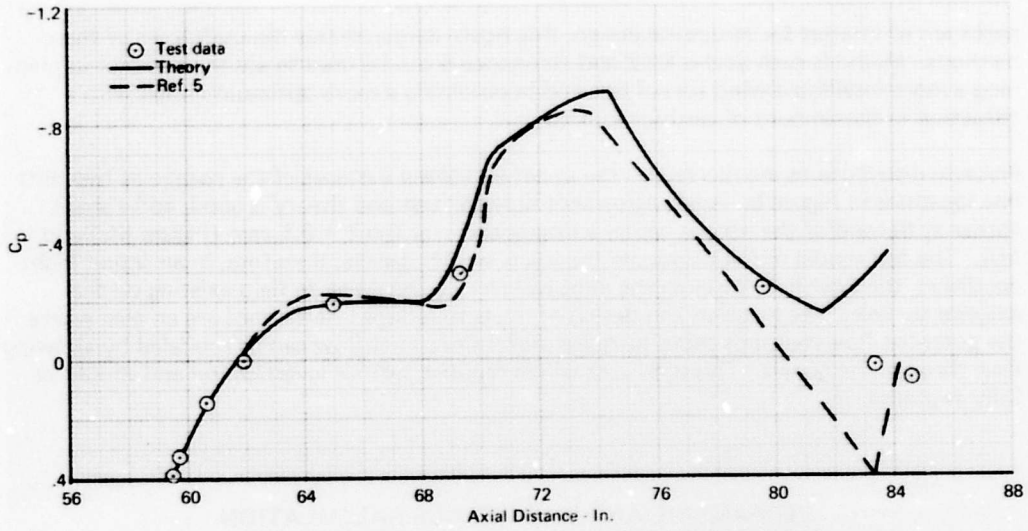

d.  $Z = 11.3$  inches

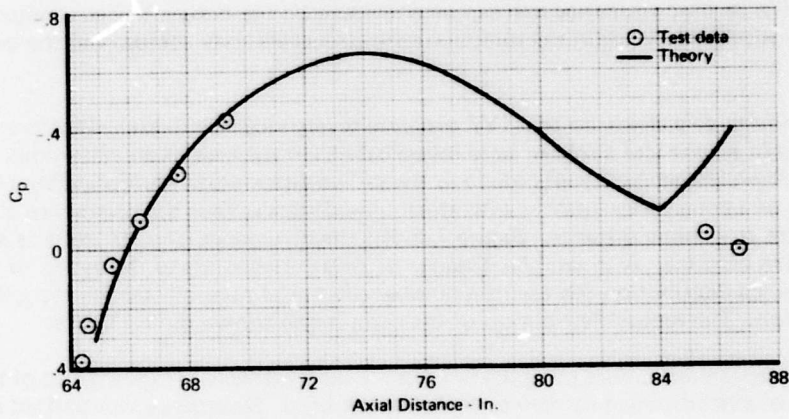

e.  $Z = 15.1$  inches

Figure 5 - continued.

peaks are of interest for structural design, this figure demonstrates the usefulness of these methods. Methods such as the XYZ and Reference 5 can be used to aid the designer in planning a more intelligent wind tunnel test and in obtaining a more optimum design with a reduction in the amount of testing required.

Pressure distributions are plotted on the upper and lower surfaces of the nacelle at two butt line locations in Figure 6. Again agreement between test and theory is good, and a sharp corner at the end of the nacelle causes a discrepancy for the  $Y = 8.5$  case (Figure 6(c) and (d)). The test model did not simulate the inlets on the nacelle; therefore, in an actual flight condition, the flow field through the inlet will change the pressure field existing on the exterior surface. The location and design of inlets to reduce interference are an area where the potential flow methods could be quite useful since inlet flow can be modeled by allowing flow through the panels. This is an area which requires further investigation and should be fully explored.

## STREAMLINE AND DIVERGENCE CALCULATION

### GENERAL DISCUSSION AND PROGRAM CHECKOUT

Streamline divergence is defined in Reference 2. Streamline divergence as a function of streamline distance can be determined as a function multiplied by an arbitrary constant. In order to make the value of the divergence unique, the divergence in the XYZ program is arbitrarily specified as 1 at the starting point of the streamline. The streamline starting point is specified as an input quantity and can be anywhere on the body. The streamline is determined in both the forward (in the direction of the local velocity vector) and the backward direction.

In order to provide a check on the XYZ program divergence calculation, the streamlines and divergences of a cone and a sphere were investigated. In the case of an axisymmetric body, the streamline divergence should reduce to the radius distribution multiplied by a constant. The radius of a cone varies linearly with streamline distance; thus the divergence also varies linearly with streamline distance. Figure 7 shows the divergence of a  $30^\circ$  cone as a function of streamline distance. A streamline distance of zero corresponds to the vertex of the cone. The divergence distribution represents a number of conical rays, all starting from the same axial location. The radius distribution of the cone is also shown on the figure.

The sphere represents a more complicated case. Figure 8 shows the divergence of a sphere as a function of axial distance for two different streamlines. Divergence was plotted against axial distance in this case because the radius distribution, also shown in the figure, is a circle. An axial distance of zero corresponds to the center of the sphere. The starting point of each streamline calculation is denoted by a circle. If the magnitudes of the radius distributions at the corresponding axial locations of the starting points of each streamline are taken and multiplied by their corresponding divergence distributions, the divergence curves will reduce to the radius curve, thus providing a check on the calculation.

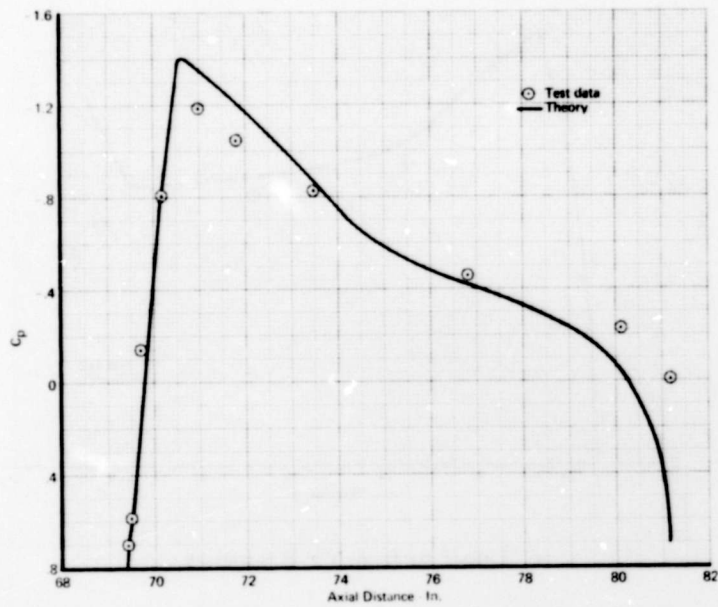

a. Upper surface, Y = 6 inches

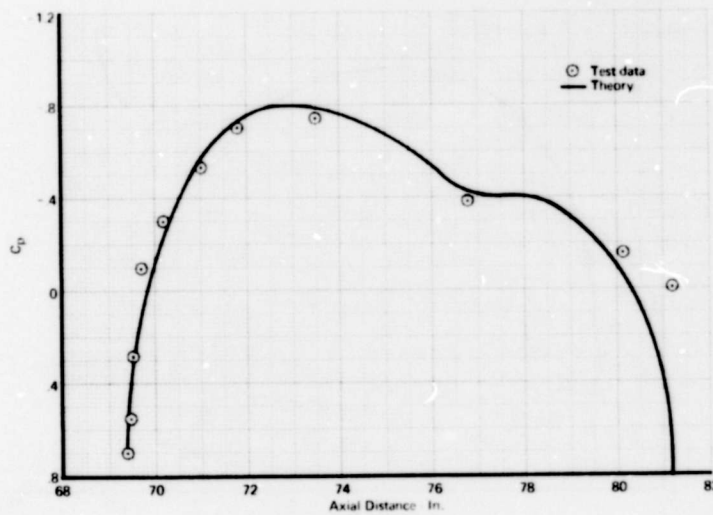

b. Lower surface, Y = 6 inches

Figure 6. Pressure coefficient versus axial distance on nacelle of HLH model.

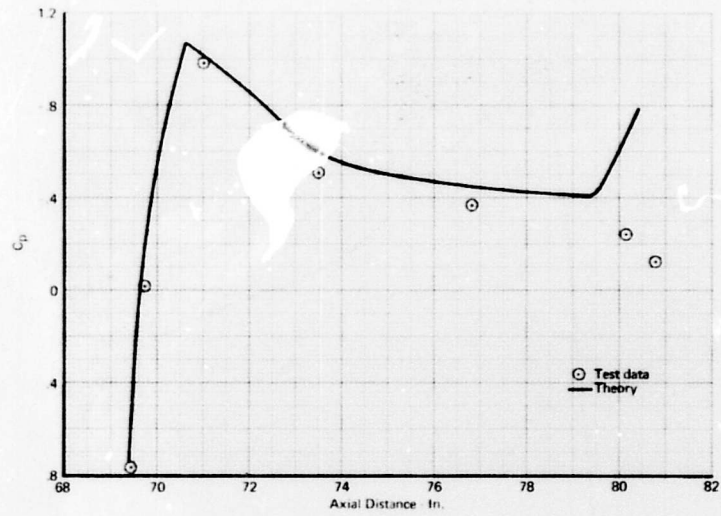

c. Upper surface, Y = 8.5 inches

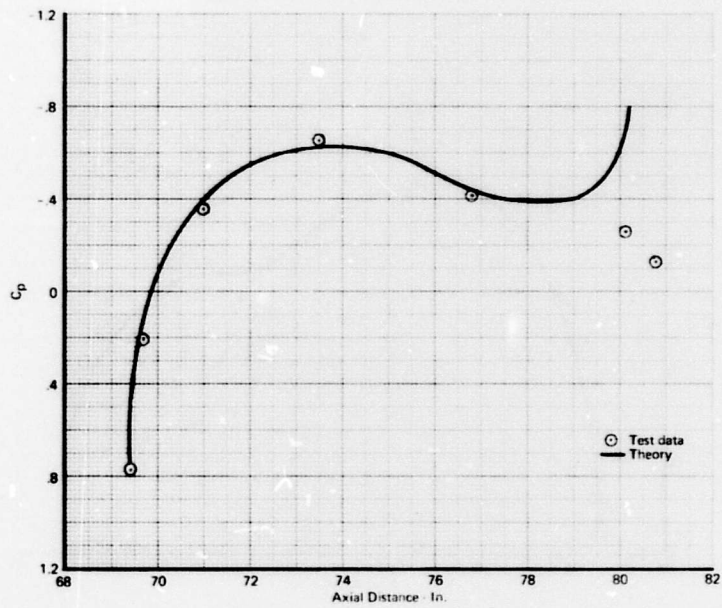

d. Lower surface, Y = 8.5 inches

Figure 6 - continued.

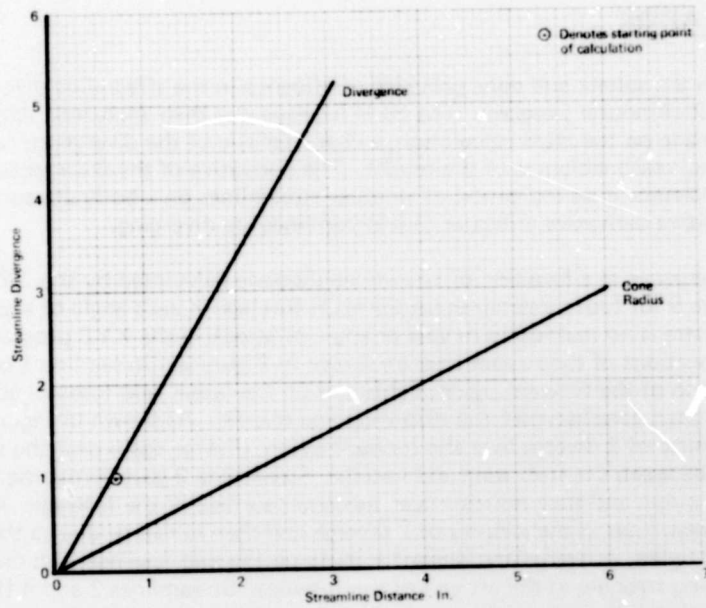

Figure 7. Streamline calculation on 30° cone.

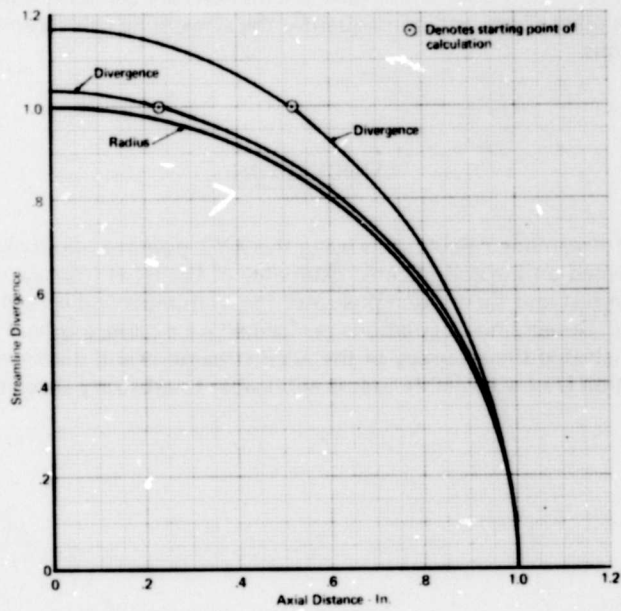

Figure 8. Streamline calculation on sphere.

## HLH CALCULATION

Calculations on the sphere and cone provided confidence in the streamline divergence calculation in the XYZ computer program. The HLH fuselage was then analyzed. Although no direct check can be made on the HLH calculation, a characteristic of the divergence can be used to check the overall reasonableness of the results. The derivative of the divergence with respect to streamline distance is an indication of whether streamlines on a body are converging or diverging. A positive derivative indicates that streamlines are diverging.

Streamline divergence as a function of streamline distance calculated by the XYZ program is shown in Figure 9 for four streamlines on the HLH fuselage at zero angle of attack and zero yaw angle. (There is no restriction in yaw or angle of attack in the XYZ program.) The approximate locations of the streamlines are shown in Figure 2. Streamline 1 goes across the upper portion of the forward pylon, continues on the upper mid fuselage going above the stub wing, and then goes between the stub wing and nacelle. As shown in Figure 9(a), streamlines in the vicinity of 1 diverge over the forward pylon, diverge again near the stub wing, and then converge between the stub wing and nacelle. Streamline 2 goes across the lower portion of the forward pylon and then remains near the lower surface of the fuselage. As shown in Figure 9(b), streamlines in the vicinity of 2 diverge and then converge due to the observer cab on the forward pylon, converge and diverge slightly on the mid fuselage, and diverge slightly before converging strongly at the aft end of the fuselage. Streamlines 3 and 4 (Figure 9(c) and (d)) are on the stub wing and nacelle and begin at the respective leading edges.

The XYZ program provides tables of streamline distance, divergence, axial distance, and pressure coefficient which are required for a boundary layer analysis along streamlines. It should be pointed out that the potential flow calculations are generally valid in regions where no flow separation takes place, and consequently the streamline calculation is valid only in attached flow regions.

## CONCLUSION

Potential flow and streamline calculations using the XYZ potential flow program have been successfully performed on the complicated geometry of the HLH fuselage model. The excellent agreement between test and theory demonstrates the usefulness and versatility of the XYZ computer program. Streamline calculations performed on a cone, a sphere, and an HLH scale model have demonstrated the accuracy of the XYZ streamline and divergence calculation. A streamline calculation is now available that is applicable to arbitrary three-dimensional nonlifting bodies.

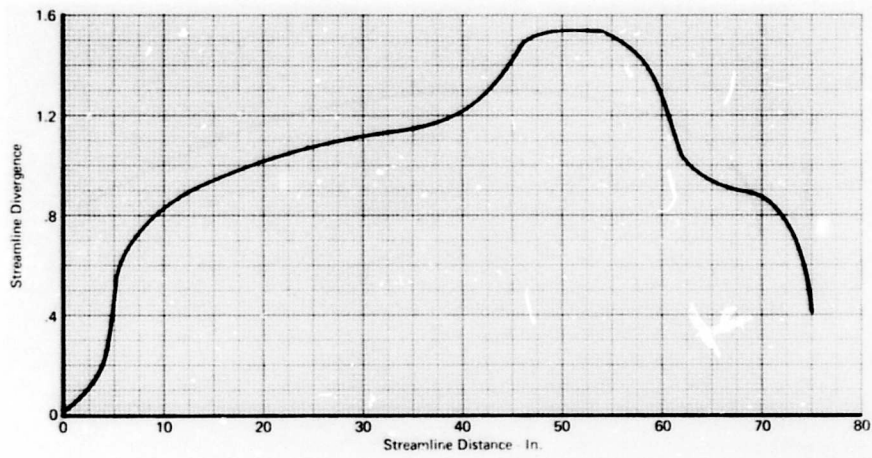

a. Streamline No. 1

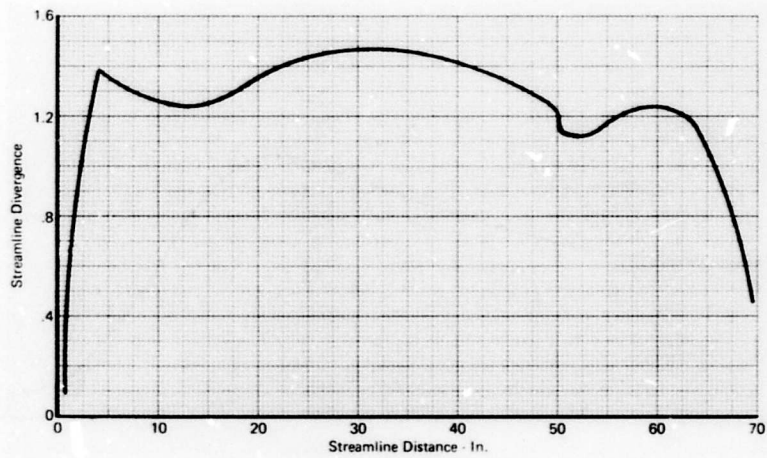

b. Streamline No. 2

Figure 9. Streamline calculation on HLH fuselage.

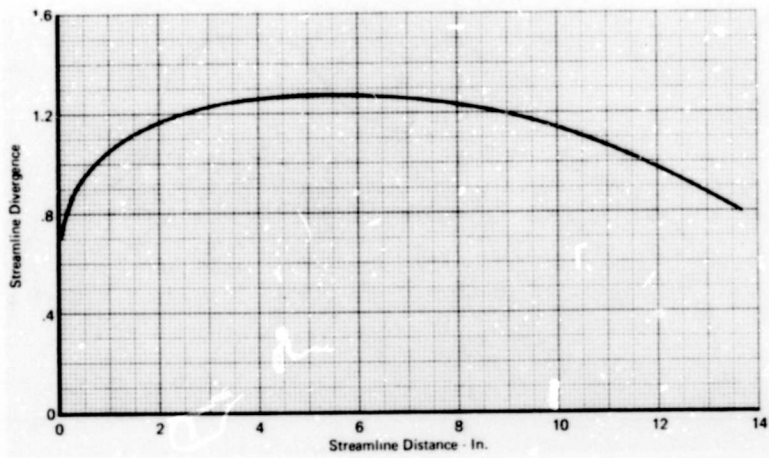

c. Streamline No. 3

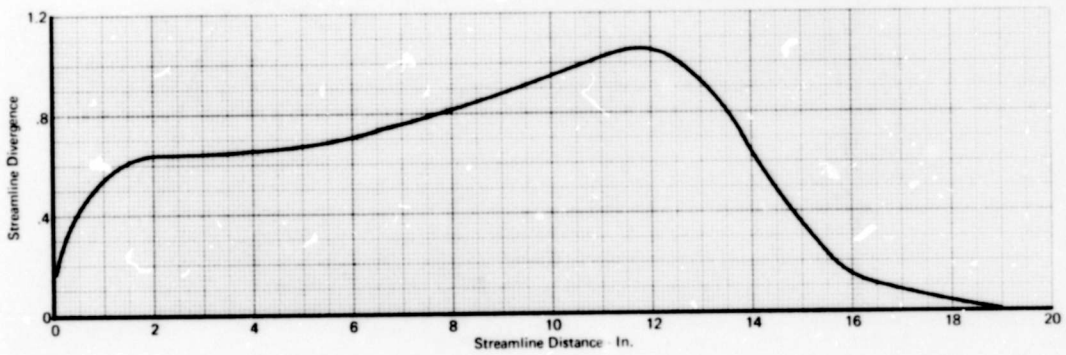

d. Streamline No. 4

Figure 9 - continued.

## REFERENCES

1. Gillespie, J., *An Investigation of the Flow Field and Drag of Helicopter Fuselage Configurations*, AHS 29th Annual Forum, May 1972.
2. DeJarnette, Fred R., *Calculation of Inviscid Surface Streamlines and Heat Transfer on Shuttle Type Configurations*, NASA CR-111921, August 1971.
3. Dawson, Charles W., and Dean, Janet S., *The XYZ Potential Flow Program*, NSRDC Report 3892, June 1972.
4. Julian, D. T., *Wind Tunnel Tests To Measure Surface Pressure Distributions on the 1/12th Scale of the Boeing Vertol Heavy Lift Helicopter (HLH)*, Boeing Report D210-10676-1, July 1973.
5. Woodward, F. A., Dvorak, F. A., and Geller, E. W., *A Computer Program for Three-Dimensional Lifting Bodies in Subsonic Inviscid Flow*, USAAMRDL-TR-74-18, Eustis Directorate, U. S. Army Air Mobility Research and Development Laboratory, Fort Eustis, Virginia, April 1974.