

AD-783 444

DEVELOPMENT PROGRAM FOR FIELD-REPAIR-  
ABLE/EXPENDABLE MAIN ROTOR BLADES.  
PHASE I. PRELIMINARY DESIGN

Michael C. Frengley

Kaman Aerospace Corporation

Prepared for:

Army Air Mobility Research and Development  
Laboratory

April 1974

DISTRIBUTED BY:

**NTIS**

National Technical Information Service  
U. S. DEPARTMENT OF COMMERCE  
5285 Port Royal Road, Springfield Va. 22151

## EUSTIS DIRECTORATE POSITION STATEMENT

The data contained in this report are the Phase I results of the design, fabrication, test, and evaluation for operational suitability of a highly field repairable/expendable helicopter main rotor blade concept, to be cost effective on a life-cycle basis. Phase I, Preliminary Design, included selection of the design approach, materials selection, stress and dynamic analysis, reliability analysis, survivability analysis, and a preliminary life-cycle cost study. The primary importance of Phase I is that reliability and maintainability constraints were defined and made a part of the design process for this rotor blade.

The report has been reviewed by the Eustis Directorate, U.S. Army Air Mobility Research and Development Laboratory and is considered to be technically sound.

This program is being conducted under the technical management of Mr. Arthur J. Gustafson, Jr., Technology Applications Division.

### DISCLAIMERS

The findings in this report are not to be construed as an official Department of the Army position unless so designated by other authorized documents.

When Government drawings, specifications, or other data are used for any purpose other than in connection with a definitely related Government procurement operation, the United States Government thereby incurs no responsibility nor any obligation whatsoever; and the fact that the Government may have formulated, furnished, or in any way supplied the said drawings, specifications, or other data is not to be regarded by implication or otherwise as in any manner licensing the holder or any other person or corporation, or conveying any rights or permission, to manufacture, use, or sell any patented invention that may in any way be related thereto.

Trade names cited in this report do not constitute an official endorsement or approval of the use of such commercial hardware or software.

### DISPOSITION INSTRUCTIONS

Destroy this report when no longer needed. Do not return it to the originator.

ACCESSION BY		
DTIC	White Section	<input checked="" type="checkbox"/>
DDC	Staff Section	<input type="checkbox"/>
UNANNOUNCED		<input type="checkbox"/>
JUSTIFICATION		
BY		
DISTRIBUTION/AVAILABILITY CODES		
Dist.	AVAIL. and/or	SPECIAL
A		

Unclassified

AD-783 444

SECURITY CLASSIFICATION OF THIS PAGE (When Data Entered)

REPORT DOCUMENTATION PAGE		READ INSTRUCTIONS BEFORE COMPLETING FORM
1 REPORT NUMBER USAAMRDL-TR-73-102	2 GOVT ACCESSION NO.	3 RECIPIENT'S CATALOG NUMBER
4 TITLE (and Subtitle) DEVELOPMENT PROGRAM FOR FIELD-REPAIRABLE/ EXPENDABLE MAIN ROTOR BLADES PHASE I - PRELIMINARY DESIGN	5 TYPE OF REPORT & PERIOD COVERED Interim Report	
	6 PERFORMING ORG. REPORT NUMBER R-1062	
7 AUTHOR(s) Michael C. Frengley	8 CONTRACT OR GRANT NUMBER(s) DAAJ02-73-C-0006	
9 PERFORMING ORGANIZATION NAME AND ADDRESS Kaman Aerospace Corporation Old Windsor Road Bloomfield, CT 06002	10 PROGRAM ELEMENT, PROJECT, TASK AREA & WORK UNIT NUMBERS Project 1F163204D835	
11 CONTROLLING OFFICE NAME AND ADDRESS Eustis Directorate U.S. Army Air Mobility R&D Laboratory Fort Eustis, VA 23604	12 REPORT DATE April 1974	
	13 NUMBER OF PAGES 316	
14 MONITORING AGENCY NAME & ADDRESS (if different from Controlling Office)	15 SECURITY CLASS. (of this report) Unclassified	
	15a. DECLASSIFICATION/DOWNGRADING SCHEDULE	
16 DISTRIBUTION STATEMENT (of this Report) Approved for public release; distribution unlimited.		
17 DISTRIBUTION STATEMENT (of the abstract entered in Block 20, if different from Report)		
18 SUPPLEMENTARY NOTES		
19 KEY WORDS (Continue on reverse side if necessary and identify by block number) Repair Rotor Blades Repair Costs		
20 ABSTRACT (Continue on reverse side if necessary and identify by block number) This report presents the work done in evaluating the design concepts applicable to helicopter main rotor blades; assessing cost, repairability, maintainability, and survivability; and determining overall blade-related costs for the helicopter life cycle. The concept showing the most potential for improved operating costs, without technical compromise, is chosen for further development.  The application of maintainability and reliability criteria during the preliminary design phase has resulted in a significant theoretical reduction in potential blade-related life-cycle costs.		

DDC  
 RECEIVED  
 AUG 8 1974  
 RECEIVED  
 D

DD FORM 1 JAN 73 1473

EDITION OF 1 NOV 68 IS OBSOLETE

Unclassified

SECURITY CLASSIFICATION OF THIS PAGE (When Data Entered)

Unclassified

SECURITY CLASSIFICATION OF THIS PAGE(When Data Entered)

Block 20

These criteria were applied to all the field repairable/expandable main rotor blade concepts examined, and all show a reduction in cost below that of the current blade.

The selected concept has extruded aluminum spar and trailing-edge spline, glass-fiber-reinforced-plastic skins, nylon paper honeycomb core, and built-up laminated metal root.

Unclassified

1  
1-A SECURITY CLASSIFICATION OF THIS PAGE(When Data Entered)

## PREFACE

A development program for field-repairable/expendable main rotor blades for helicopters is being performed under Contract DAAJ02-73-C-0006 with the Eustis Directorate, U. S. Army Air Mobility Research and Development Laboratory, Fort Eustis, Virginia, under the general technical cognizance of Mr. Arthur J. Gustafson of the Structures area, Technology Applications Division, and Mr. Royace H. Prather of the Reliability and Subsystems area, Military Operations Technology Division. The preliminary design and concept selection phase of the program has been completed.

The author acknowledges the contributions made by Messrs. J. Carver (Rockwell International, Tulsa), S. Barlow and J. Wynkoop (Adhesive Engineering, Airline Systems Div.), and G. P. Basile, A. Belbruno, M. A. Bowes, T. N. Cook, P. F. Maloney, J. E. Miller, D. Ojantakanen, M. Powers, P. Sevenoff, W. A. Smyth, M. White, E. Wilk, R. L. Young and many other members of the Kaman Aerospace Corporation staff.

TABLE OF CONTENTS

	<u>Page</u>
PREFACE . . . . .	iii
LIST OF ILLUSTRATIONS . . . . .	vii
LIST OF TABLES . . . . .	xi
INTRODUCTION . . . . .	1
METHODOLOGY . . . . .	4
APPROACH TO A DESIGN SPECIFICATION . . . . .	4
TECHNICAL CRITERIA . . . . .	5
RELIABILITY AND MAINTAINABILITY CRITERIA . . . . .	6
SURVIVABILITY CRITERIA . . . . .	7
FAILURE MODES AND EFFECTS ANALYSIS . . . . .	8
LIFE-CYCLE COST ANALYSIS . . . . .	9
COMPUTER METHODS . . . . .	10
CANDIDATE DESIGN CONCEPTS . . . . .	14
FABRICATION CONCEPTS . . . . .	16
MATERIAL CHOICES . . . . .	18
PRELIMINARY EVALUATION AND FURTHER SELECTION . . . . .	23
SELECTED DESIGN APPROACHES . . . . .	27
CHOICE OF FABRICATION TECHNIQUES . . . . .	27
CHOICE OF MATERIALS . . . . .	42
CHOICE OF AIRFOIL SECTION . . . . .	45
CONCEPTS WITH EXTRUDED ALUMINUM SPARS . . . . .	46
CONCEPTS WITH FORMED SHEET STAINLESS-STEEL SPARS . . . . .	46
TECHNICAL ANALYSIS . . . . .	48
CURRENT UH-1H MAIN ROTOR BLADE CHARACTERISTICS . . . . .	48
SECTION PROPERTIES . . . . .	48
WEIGHT AND BALANCE . . . . .	59
CENTRIFUGAL AND STATIC LOADS AND MOMENTS . . . . .	59
NATURAL FREQUENCIES . . . . .	59
DYNAMIC BENDING MOMENTS . . . . .	59
STRESS ANALYSIS . . . . .	59

	<u>Page</u>
RADAR CROSS SECTION . . . . .	75
ACOUSTIC SIGNATURE. . . . .	75
RELIABILITY AND MAINTAINABILITY. . . . .	81
FAILURE MODES AND EFFECTS . . . . .	82
MAINTENANCE ACTIONS AND TIMES . . . . .	96
SURVIVABILITY. . . . .	111
LIFE-CYCLE COSTS . . . . .	116
CONCLUSIONS. . . . .	124
POTENTIAL FOR ACHIEVING PROGRAM GOALS . . . . .	124
CONCEPT SELECTION . . . . .	125
LITERATURE CITED . . . . .	126
APPENDIXES	
I. DESIGN SPECIFICATION, HELICOPTER MAIN ROTOR BLADE . . . . .	129
II. RELIABILITY PROGRAM PLAN. . . . .	140
III. MAINTAINABILITY PROGRAM PLAN. . . . .	155
IV. RCS EVALUATION OF REPAIRABLE/EXPENDABLE MAIN ROTOR BLADE DESIGN CONCEPTS. . . . .	203
V. FAILURE MODES AND EFFECTS ANALYSIS. . . . .	216
VI. MAINTENANCE ACTIONS AND TIMES . . . . .	239
VII. LIFE-CYCLE COST ANALYSIS. . . . .	257
LIST OF SYMBOLS . . . . .	300

LIST OF ILLUSTRATIONS

<u>Figure</u>		<u>Page</u>
1	Rotor Blade Life-Cycle Cost Model and Computer Flow Chart . . . . .	11
2	Modulus Variation With Fiber Orientation, Glass-Fiber-Reinforced Plastic . . . . .	20
3	Concept 1. . . . .	29
4	Concept 3. . . . .	31
5	Concept 5. . . . .	33
6	Blade Sections at Station 28.0 . . . . .	35
7	Blade Sections at Station 81.0 . . . . .	37
8	Blade Sections at Station 210.0 . . . . .	39
9	Blade Sections Extrapolated to Station 288.0 . . . . .	41
10	Weight Distribution, Current UH-1H Blade . . . . .	50
11	Center of Gravity Location, Current UH-1H Blade. . . . .	51
12	Axial Stiffness Distribution, Current UH-1H Blade . . . . .	52
13	Neutral Axis Location, Current UH-1H Blade . . . . .	53
14	Flapwise Bending Stiffness Distribution, Current UH-1H Blade. . . . .	54
15	In-Plane Bending Stiffness Distribution, Current UH-1H Blade. . . . .	55
16	Natural Frequencies, Current UH-1H Blade . . . . .	56
17	Dynamic Flapwise Bending Moments, Current UH-1H Blade. . . . .	57
18	Dynamic In-Plane Bending Moments, Current UH-1H Blade. . . . .	58

<u>Figure</u>	<u>Page</u>
19 Weight Distribution, Concept 2 . . . . .	60
20 Center of Gravity Location, Concept 2 . . . . .	61
21 Axial Stiffness Distribution, Concept 2 . . . . .	62
22 Neutral Axis Location, Concept 2. . . . .	63
23 Flapwise Bending Stiffness Distribution, Concept 2 . . . . .	64
24 In-Plane Bending Stiffness Distribution, Concept 2 . . . . .	65
25 Centrifugal Loading Distributions, Concept 2 . . . . .	68
26 Static Bending, Concept 2 . . . . .	69
27 Natural Frequencies, Concept 2. . . . .	70
28 Dynamic Flapwise Bending Moments, Concept 2 . . . . .	71
29 Dynamic Edgewise Bending Moments, Concept 2 . . . . .	72
30 Airfoil Pressure Distribution for 0015, 0012, and FREB Type II Airfoils . . . . .	79
31 Rotor Speed vs. Forward Airspeed for Constant Aural Detection Range . . . . .	80
32 Field Repair Scheme, Skin Patch . . . . .	106
33 Field Repair Scheme, Skin-Core Plug Patch . . . . .	107
34 Field Repair Scheme, Skin-Core Through Patch. . . . .	108
35 Field Repair Blend Limits, Trailing Edge. . . . .	109
36 Field Repair Blend Limits, Root Reinforcement . . . . .	110
37 Life-Cycle Costs vs. Initial Procurement Costs . . . . .	118
38 Life-Cycle Costs vs. Mean Time Between Failures . . . . .	119

<u>Figure</u>		<u>Page</u>
39	Life-Cycle Costs vs. Field Repairability . . .	120
40	Life-Cycle Costs vs. Fatigue-Limited Service Life . . . . .	121
41	Life-Cycle Costs vs. Mean Time Between Failures, Noncombat Environment. . . . .	122
42	Life-Cycle Costs vs. Field Repairability, Noncombat Environment. . . . .	123
43	Reliability Program Schedule . . . . .	154
44	Maintainability Information Flow . . . . .	157
45	Observed Repair Time Distribution for the UH-2C Airframe System and Fitted Lognormal Distribution . . . . .	166
46	Observed Repair Time Distribution for the UH-2C Rotor System and Fitted Lognormal Distribution . . . . .	167
47	Variance of the Logarithms of Repair Time, $\text{Var } x$ , Versus the Mean of the Logarithms, $\bar{X}$ for 52 UH-2C Helicopter Subsystems . . . . .	174
48	Variance of the Logarithms of Repair Time, $\text{Var } x$ , Versus the Logarithms of the Mean-Time-To-Repair, $\text{Log}_{10} \text{ MTTR}$ , for 52 UH-2C Helicopter Subsystems . . . . .	175
49	Cumulative Repair Time Distributions for $M_{\text{max}}$ of 3.0 Hours at Two Different Values of $\sigma_x$ . . . . .	178
50	Maintainability Trade-offs . . . . .	180
51	Maintainability Allocation Data Format . . .	183
52	Maintenance Plan Format. . . . .	190
53	Maintenance Requirements Data Format . . . .	191
54	Sample Repair Kit Contents . . . . .	193

<u>Figure</u>		<u>Page</u>
55	Sample Repair Kit Use Frequencies . . . . .	194
56	Sample Equipment List . . . . .	195
57	Maintainability Program Schedule. . . . .	200
58	$\Delta$ LE Vs TE - UH-lH Metal LE >+ . . . . .	205
59	Design 2 (Reference 3) Metallized Vs Design 2 Fiberglass Trailing Edge Comparison, Design 2 Fiberglass >+. . . . .	206
60	Design 2 (Reference 3) TE Vs LE - UH-lH TE > +. . . . .	208
61	Carbon Loaded Core TE Vs LE, Design 2 (Reference 3), LE >+ . . . . .	209
62	LE Peak Value $\Delta$ Due to Increased Radius . .	210
63	Leading-Edge 0-Degree Pitch Aspect Angle Peak Value Comparison . . . . .	212

LIST OF TABLES

<u>Table</u>		<u>Page</u>
I	Design Concepts Examined. . . . .	28
II	Weight and Balance, Current UH-1H Blade . .	49
III	Weight and Balance, Concept 2 . . . . .	66
IV	Weight and Balance Summary. . . . .	67
V	Basic Stress Analysis Summary . . . . .	73
VI	Failure Rate Computations, Current UH-1H Blade . . . . .	84
VII	Failure Rate Computations, Concept 1. . . .	88
VIII	Failure Rate Computations, Concept 3. . . .	92
IX	Failure Rate Summary, Current UH-1H Blade .	97
X	Failure Rate Summary, Concept 1 . . . . .	98
XI	Failure Rate Summary, Concept 3 . . . . .	99
XII	MTBF Summary, Current UH-1H Blade . . . . .	100
XIII	MTBF Summary, Concept 1 . . . . .	101
XIV	MTBF Summary, Concept 3 . . . . .	102
XV	Potential Damages and Maintenance Actions, Concept 1 . . . . .	103
XVI	Potential Damages and Maintenance Actions, Concept 3 . . . . .	104
XVII	Damage Data for Survivability Analysis. . .	112
XVIII	Life-Cycle Cost Summary . . . . .	117
XIX	Maintainability Analysis Data Base, UH-2A/2B Helicopter . . . . .	162
XX	Maintainability Analysis Data Base, UH-2C Helicopter. . . . .	164

<u>Table</u>	<u>Page</u>
XXI	Leading-Edge 0-Degree Pitch Aspect Angle Peak Value RCS Comparison (dB) . . . . . 211
XXII	Predicted Maintenance Actions/MTTR, Concepts 1 and 2. . . . . 240
XXIII	Predicted Maintenance Actions/MTTR, Concepts 3 and 4. . . . . 245
XXIV	Field Repairable/Expendable Rotor Blade (Preliminary Mean Repair Times) . . . . . 250
XXV	Repair Kit Contents . . . . . 252
XXVI	Equipment List, Blade Repair. . . . . 255

## INTRODUCTION

The cost of acquiring and maintaining a fleet of helicopters is affected to a significant extent by the costs incurred in acquiring, maintaining, and replacing the rotor blades. Experience has shown that few rotor blades operating in the Army's utility fleet in a hostile climatic and military environment ever reach their fatigue-limited allowable service life. It is apparent that the main rotor blade costs can be reduced by increasing the number of repairs performed successfully in the field, and by reducing acquisition and replacement costs so that unrepairable blades can be economically abandoned. The concept of a field-repairable/expendable main rotor blade is intended to meet these objectives.

The aim of the development program is not only to develop a new rotor blade having improved life-cycle costs. In fact, the flight vehicle, the UH-1H helicopter, is nearing obsolescence and a new rotor blade design is not now warranted. Methodology will be developed applicable to future rotor blade procurement for new model helicopters, providing means whereby maintainability and survivability criteria can be incorporated and evaluated during the earliest design phases. Expensive depot repair, its accompanying logistical complexity, and high scrap rates may thus be avoided in the future.

The development program itself is divided into five phases. In Phase I, the methodology has been developed and the selection made of a basic blade design on which this methodology can be tested. In Phase II, the detail design and analysis of both the blade and its repair schemes will be completed and the drawings issued for manufacturing. The test blades will be fabricated and ground structural and whirl tower testing will be performed in Phase III, and flight tests will take place in Phase IV. In Phase V, the results of the program will be analyzed and the methodology refined to reflect the ground and flight testing and the repair performance experienced.

This report covers the work done under Phase I of the program. At the start of the program, the types of damage experienced by UH-1H main rotor blades in operation, the relative rates of occurrence of each type of damage, and the dispositions were examined in order to determine in which areas improvement could best be made. The damage, repair, and scrap history of current blades is accumulated in Reference 1 based on Army records. A machine-generated damage scenario, representative of the externally-caused damage events experienced in the field, was used in Reference 2 so that types of damage requiring repair

could be placed on a quantitative basis. These types of damage were modified as to depth and severity to account for differences in materials between the current UH-1H blade and the repairable concepts under study. In Reference 3, the damage events and dispositions described in Reference 1 were used directly. Similar extensive analyses were used to provide the bases for repair costs in References 4 and 5. For this program, a combination of the causes and dispositions collected in Reference 1 and the modified damage scenario of Reference 2 is used as the basis of a Failure Modes and Effects Analysis. The validity of the Army's damage scenario was verified during the study of Reference 2, which showed that the dispositions obtained by applying the scenario to the current blade closely approximated those presented in Reference 1.

A tentative design specification, conforming to the repairability criteria, reflecting the types of incidents reported in Reference 1 and quantified in the damage scenario, detailing the technical requirements, and providing criteria for survivability, cost, and environmental resistance, was drawn up. This specification was drawn from the results of the studies outlined in References 2, 3, 4, and 5 and determined the acceptability for further study of the concepts examined in those references. This preliminary design specification is presented in Appendix I. At the conclusion of the program, this specification will be examined and a final version drawn up reflecting the results of the hardware tests.

The blade concepts presented in References 2 through 7, together with other possible combinations of materials and techniques, were examined with respect to this preliminary design specification. As a result of the evaluation, which covered twenty-six different approaches, two basic types of blade construction were chosen for further development. With detail variations, these two basic types provided twelve different detail designs.

Following the selection of the blade concepts for further development, designs were prepared in greater detail and a technical analysis was performed to determine adequacy of each design for use on the UH-1H helicopter in the basic utility mission. Natural frequency, bending moment, and stress analyses were performed to ensure that the structure was equal to that of the current blade. Repair schemes were drawn up, and estimates of their structural adequacy and conformance with the maintainability criteria were made. The radar cross sections and acoustic signatures were estimated and compared to those of the current UH-1H blade.

A reliability analysis predicting the probable failure and damage occurrences, based on a comparison of the designs under study with the standard UH-1H blade, was made; and modes, causes, and rates of failure were predicted. A survivability analysis utilizing the damage scenario, as modified for the appropriate materials, was also made.

A maintainability prediction based on the repair schemes and predicted failures was made. During the design process, any inadequacies in maintainability, particularly with respect to skill level and elapsed active repair times, were noted and any necessary design changes were made. The maintainability requirements had considerable influence in the choice of the aft skin material and, to a lesser extent, the structural adhesives used in the blade construction. The tips were designed for ease of access, to facilitate balance weight adjustment following repairs. However, in general, the effect of maintainability criteria on design decisions was negative, vetoing unsuitable materials and methods of construction, rather than positively indicating favorable choices.

Finally, to provide the quantitative basis on which to compare blade concepts and make the final selection, a life-cycle cost analysis was performed for each of the twelve design variants. This cost analysis was based on a 10-year, 5000-hour aircraft life and a 10,000-unit blade procurement quantity, and used the failure modes and rates, the repair labor, and the scrap or repair dispositions predicted by the reliability, survivability and maintainability analyses, along with manufacturing costs estimated for each concept. Such fixed costs as inspection and those associated with logistics were included but did not vary between differing concepts. The costs of the standard UH-1H blade were obtained on the same basis so as to give a measure of the improvement to be gained by treating maintainability, particularly repairability, as a major design constraint.

This report covers the results of all of the evaluations, analyses, and predictions leading to the selection of the final concept to be designed, fabricated, and tested during the remaining phases of the program. The selected concept and the reasons for the choice are presented.

## METHODOLOGY

Since the primary purpose of this development program is to create and refine methodology by which maintainability requirements can be incorporated into the preliminary design process, it is appropriate to describe the approach taken during Phase I.

Initially, a design specification was drawn up reflecting the damage incidents incurred by the blades as presently in service, and providing the technical requirements for the new blade design. Reliability and maintainability criteria, survivability, and technical requirements such as stiffness, strength, static deflection, weight and balance, and detectability by radar and acoustics were specified. Potential concepts were examined with respect to this specification, and those which conformed most closely, and with the greatest certainty, were examined further.

For this program, the criteria, particularly the technical requirements, were drawn up by comparison with the characteristics of the blade currently used on the UH-1H helicopter. For a new blade program, where the criteria would be applicable to a new helicopter, the design specification should be more directly related to the airframe, the mission, and the rotor system.

When each blade concept was sufficiently well defined, a failure modes and effects analysis was performed and the maintainability characteristics were determined for repair of these failures. In any instance where the maintainability fell short of the criteria, design changes were made, but in the preliminary design phase such changes were few.

Finally, the blade-related life-cycle costs were analyzed for a helicopter life span of 5,000 hours. These costs included acquisition, repair, scrap, retirement, replacement, and logistics. The life-cycle cost analysis provides a quantitative comparison of competing blade concepts, placing a dollar value on such qualities as reliability and repairability.

### APPROACH TO A DESIGN SPECIFICATION

Traditionally, a rotor blade design specification, if formalized as a separate document at all, spells out the required performance characteristics in terms of airfoil section, chord length, rotor radius, hub interface, probably desired dynamic

and structural limits, and very little else. In most cases, however, the blades are procured as integral parts of the aircraft system, and their requirements are implicit in the total specification, rather than explicitly presented in a separate document. This has resulted in rotor blades designed and manufactured with their reliability, vulnerability, and maintainability treated, somewhat cursorily, as small parts of those of the overall system. Recent operational experience has shown that blade-related costs are significantly high, sufficiently so that potential savings, by treating blade characteristics specifically, amount to ten million dollars annually for a typical U. S. Army helicopter fleet. An important part of this program is to generate guidelines and create a typical design specification for helicopter blades, which can be either a separate document or incorporated as explicit blade items in the overall system specification.

As well as those technical characteristics determined by aerodynamic performance requirements, others such as weight, centrifugal force, balance, and the natural frequencies of primary modes should be defined. If there is a possibility of tip deflection being critical, this limitation should be given. Radar and acoustic detectability may be included. Most important, the operational characteristics and limitations in the areas of reliability, maintainability, survivability, and acquisition cost must be defined.

The preliminary blade design specification prepared for this phase of the program is included as Appendix I of this report. The specification will be revised to incorporate any changes indicated by the test programs to be performed under Phases III and IV.

#### TECHNICAL CRITERIA

Because the field-repairable/expendable rotor blades are intended for use on an already operational helicopter, the technical definition of the blades is developed by comparison with the known characteristics of the blades currently in service.

The contractor's standard machine program was used to generate the mass and stiffness properties for the selected basic design concepts at significant cross sections, and these section properties were then compared with the equivalent properties of the current blade. The program accepts a series of coordinates describing points on the boundary of each component section, and generates the geometric properties (area, centroid, and first and second moments of area). These geometric properties are then multiplied by the respective material weight

densities and summed for the total section weight and inertia per unit length and section center of gravity. Summing the products with the respective material moduli of elasticity gives the total section axial and bending stiffnesses and the neutral axis.

The section properties were introduced into the contractor's standard dynamic analysis machine programs, and natural frequencies and dynamic bending moments were predicted. Blade total weight and balance characteristics, centrifugal load distributions, and static bending moments and deflections were determined by computer integration of the section weights, centers of gravity, and stiffnesses. Plane section stress analysis was used to predict flight stresses and fatigue margins of safety.

Designing to section properties approximating those of the current blade ensures dynamic and structural behavior similar to that blade, so that fatigue lives will be comparable. Thus, the critical edgewise and torsional stiffnesses are specified to have the same values as those of the current blade. Other parameters, such as static deflection and centrifugal force, were calculated for the current blade by using the contractor's computer programs, and then were incorporated into the design specification. The specification thus allows comparison of the candidate concepts and the current blade on the same analytical basis.

#### RELIABILITY AND MAINTAINABILITY CRITERIA

The program plans for the reliability and maintainability evaluations, respectively, and for the incorporation of reliability and maintainability criteria into the preliminary designs are presented in Appendixes II and III.

The reliability of the candidate design concepts was examined using the known history of the current UH-1H main rotor blades, as expressed in Table D-I of Reference 1. For the design specification, those areas exhibiting the highest frequency of inherent failures were required to be minimized. Vulnerability criteria were specified in the same way, those areas most susceptible to external damage being required to be minimized. It was also possible to specify that materials susceptible to certain types of damage, such as corrosion, dents from minor impact, moisture absorption, and similar specific traits, be avoided wherever possible.

The maintainability criteria were specified such that all repairs could be performed in the field safely, successfully,

and within time limits such that less effort would be required to perform each permitted repair than to scrap the blade. Any damage events requiring repairs so extensive as not to meet these criteria would be cause for scrap. The maintenance skill level, mean time goal to perform each repair action, and the 95<sup>th</sup> percentile maximum for all repair actions are all defined in the design specification. The effect of applying these limits will be to ensure that almost all allowable repairs are carried out, in preference to scrapping the blade.

The design specification implies that the frequency and severity of damage events will be less for those designs that conform with it than for those that do not. Conformity with the specification eliminates or reduces susceptibility to corrosion, wear, impact, and adhesive bond delamination.

A failure modes and effects analysis was generated for the current blade, in accordance with the history given in Reference 1, and then modified for each of the selected candidate concepts by adjusting for the known and anticipated characteristics of the materials and details of each concept. The maintenance dispositions of the damage events occurring to the current blade were incorporated in the failure modes analysis, and similar dispositions were predicted for the candidate design concepts. In this way, blades conforming with the specification could be compared with current operational experience. The choices of disposition were repair on aircraft, repair off aircraft, scrap, or no required action. The number of off-aircraft repairs must be minimized because once the blade has been removed from the aircraft, the advantage of repair over scrap diminishes, depending on availability of a replacement blade.

Some damage occurrences require no action where a difference in wall thickness, material, or other design feature between the candidate concept and the current blade means that a dent or abrasion, for example, will have no significant structural effect within increased limits. In addition, each of the candidate concepts is designed so that certain damage occurrences are eliminated entirely. Delaminations cannot occur in a monolithic structural component replacing a built-up assembly, and nonmetals do not corrode.

#### SURVIVABILITY CRITERIA

Detectability criteria, the radar cross section and the acoustic signature, are simply specified so that the candidate concepts will be no more detectable than the current blade. Design characteristics affecting radar return and noise level are

specified as limits referred directly to the external features of the current blade.

Survivability after a damage event, particularly combat damage, is specified in terms of crack propagation rates, fail-safe load paths, and crack arresters such as changes of modulus or thickness. How well the selected design concept conforms with the specification will be determined by hardware testing in Phase III. Even partial conformity with the design specifications in this respect will result in an improvement over the current blade.

#### FAILURE MODES AND EFFECTS ANALYSIS

The approach to the reliability analysis of each design considered is presented in Appendix II, "Reliability Program Plan". In outline, Tables D-I and H-I of Reference 1 were used to compile a theoretical collection of damage events, typified by damage cause or type, and to assign frequencies of occurrence to these events as experienced by the current UH-1D/H main rotor blade. This compilation was then applied to each of the new concepts, making changes as dictated by new materials or types of construction. The location of each damage event was determined from the damage scenario for the externally caused occurrences, and from Table XIV of Reference 3 for inherent failures.

Dispositions (scrap, depot repair, or field repair) were determined in accordance with Table H-I of Reference 1 for the current blade, and by the maintainability analysis for each of the concepts being examined. These dispositions were then included in the computation of the overall failure analysis so that scrap and repair rates could be determined for each design.

Each repairable failure was investigated by a maintainability analysis, and times to repair, labor efforts required, and equipment and material requirements were generated. These times, labor requirements, and material and equipment identified as repair kits were incorporated into the failure modes and effects analysis so that a complete accumulation of these elements could be made as an integral part of the failure analysis. This computation could then be used to generate the overall 95th percentile maximum repair times, so that the failure and maintainability results could be checked against the design specification. If the specified maximum was still exceeded after all practical design changes improving repair characteristics had been incorporated, then those repairs contributing the most time were eliminated and replaced by scrap actions, reducing the overall repairability of the concept.

The repair kit requirements and labor figures were also accumulated and averaged, so that the cost elements for use in the life-cycle cost analysis were generated.

#### LIFE-CYCLE COST ANALYSIS

For each of the candidate concepts selected for further investigation, a manufacturing cost estimate was developed based on a production run of 10,000 blades. This quantity established the point on the learning curve for manufacturing labor man-hours, and the nonrecurring costs associated with tool planning, design, and fabrication were amortized over this number of units. The prototype costs, i.e., research, development, test, and engineering (RDTE), are not included in the nonrecurring costs for purposes of life-cycle cost determination.

The initial cost was combined with the costs of maintenance, replacement, shipping, and attrition to give the total blade-related costs for the helicopter life cycle. The cost model and computer flow chart by which these diverse costs are combined are shown in Figure 1.

The cost model horizontally divides the cost elements into those associated with the procurement of initial outfitting and replacement blades, including new blade price, container price, and shipping costs of blades and empty containers by sea or air as appropriate; and into those chargeable to labor and materials required to maintain the blades. The latter costs include inspection, repair, removal, replacement, alignment, and tracking, and form different combinations for repairs performed on the aircraft, off the aircraft but in the field, or at the depot. Because a major requirement of this development program is that depot repairs should be eliminated, the cost elements associated with depot repairs or depot scrap are not shown on Figure 1, but they were included in the computation of the life-cycle cost of the standard UH-1H blade. For the field-repairable/expendable concepts, all repair or scrap actions take place in the field.

The cost model is vertically divided into the procurement cost of initially outfitting the fleet, initial spares procurement including containers, and the cost of blade repair support equipment and materials; the cost of replacements for blades scrapped, retired, or lost to attrition; and the cost of all maintenance actions including labor and materials. The length of the blade supply pipeline (the elapsed time between delivery of a blade from the factory and its availability at the using unit) is taken into account in the second division, where the number of replacements is adjusted up or down according to the

rate of replacement and the length of the pipeline.

The basic equations used to generate the costs which make up the overall life-cycle blade costs are presented on pages 7 through 12 of Reference 3. One change has been made to allow the rate of retirement to vary according to the rate of scrap. This relationship is shown in Appendix II for the retirement of undamaged blades, while damaged but repairable blades are assumed to be retired when the cost of a repair exceeds the value of the remaining service life. If the value of the life remaining is assumed to be directly proportional to the initial blade price and inversely to the allowable service life, and damage events are assumed to occur at a constant rate for the operational life of the fleet, the fraction of damaged but repairable blades retired is proportional to the average cost of a repair and inversely proportional to the price of a new blade.

#### COMPUTER METHODS

The contractor has two machine computation systems, both of which were used extensively during Phase I of this program.

The contractor's standard machine programs using the large-capacity card-reading machine were used to generate section properties, natural frequencies, and dynamic bending moments. This system of hardware and software has been operational for several years and has been used successfully on many different development programs.

To enable quick decisions to be made, of particular importance for preliminary design activity, the contractor's keyboard-input conversational time-sharing computer system was used. Standard programs in this system were used to determine weight and balance characteristics by integration of section properties, and to determine stresses from the dynamic bending moments. The first of these programs takes advantage of the conversational feature of the system to make theoretical adjustments to the blade balance until the specified balance parameters are met. The system allows these changes to be made immediately.

Two special programs were written for the conversational computer system. The first of these covers the failure modes and effects analysis, incorporating the results of the maintainability analysis so that repair times and kit use can be summed and averaged. This program also produces the 95<sup>th</sup> percentile maintenance times in its output. The conversational



feature of the system here allows repair actions to be replaced by scrap actions until the specified maximum time is reached or passed below. The second special program generates life-cycle costs, using the flow chart shown in Figure 1, from the failure modes and effects computation and the estimated manufactured price of a new blade. This program is set up so that the sensitivity to significant parameters such as procurement cost, field repairability, and failure rate, can be rapidly obtained. Any of the input variables can be manipulated as required, so that sensitivity to other parameters, such as supply line elapsed time and allowable service life, can also be obtained.

The conversational time-sharing computer proved to be a valuable tool for preliminary design, because of its ability to provide immediate processing of input variables. In technical areas, it was possible to balance the blade concepts by making rapid adjustments to theoretical representations of blade tip weights, and to eliminate repetitive and tedious hand calculations by writing simple programs, such as that to obtain stresses at many points on many sections of each blade. For operational analysis, the programs for failure modes and effects and for life-cycle costs greatly reduced turnaround time for determining trends and increased both the number of parameters which could be varied and the range of those variations.

## CANDIDATE DESIGN CONCEPTS

At the outset of the program, many diverse types of construction and combinations of materials were examined. The potential for achieving the reliability, maintainability, and cost goals were evaluated for each of these concepts and those specific design features exhibiting the greatest potential were selected and combined, as appropriate, into a reduced number of concepts, which were then analyzed for technical and operational characteristics by the methodology presented above.

Twenty-two separate and distinct concepts are presented in References 2 through 6. Some design features are common to two or more of these concepts, and at least one combination of major features is repeated, but with significant differences in detail.

The 22 concepts examined in the references have the following basic blade sections:

- a. One-piece extruded aluminum alloy spar, glass-fiber-reinforced aft skins, aluminum honeycomb aft core, and extruded aluminum alloy trailing-edge spline (Reference 2, Configuration V).
- b. Glass fiber reinforced aft skins, but otherwise unchanged from the current UH-1H blade (Reference 2, Configuration I).
- c. Narrow chord titanium spar, glass-fiber-reinforced-plastic aft skins, titanium spline (Reference 2, Configuration II).
- d. One-piece extruded aluminum alloy spar with integral root buildup, glass-fiber aft skins, aluminum alloy spline (Reference 2, Configuration III).
- e. Unidirectional glass-fiber-reinforced-plastic spar and spline, glass-fiber aft skins (Reference 2, Configuration IV).
- f. All-aluminum alloy blade with one-piece extruded spar (Reference 3, Design 1).
- g. Stretch-formed stainless-steel sheet three-piece spar, drawn stainless-steel nose ballast, glass-fiber-reinforced aft skins, polyamide paper honeycomb aft core, unidirectional glass-fiber-reinforced-plastic spline (Reference 3, Design 2).

- h. One-piece extruded aluminum alloy spar, glass-fiber-reinforced-plastic aft skins, sheet aluminum shear web on chord plane, polyamide paper aft cores, extruded aluminum spline (Reference 3, Design 3).
- i. Extruded aluminum alloy spar, extruded aluminum alloy aft section (Reference 3, Design 4).
- j. Aft fairing sectionalized into short, bolted-on boxes, but otherwise changed only as necessary from the current UH-1H blade (Reference 4, Figure 14).
- k. Sectionalized glass-fiber-reinforced-plastic aft fairing, glass-fiber-reinforced-plastic spar, bolted removable leading-edge member (Reference 4, Figure 15).
- l. Four-component bolted spar with sectionalized aft fairing (Reference 4, Figure 16).
- m. Wraparound steel tube spar with sectionalized aft fairing (Reference 4, Figure 17).
- n. Extruded aluminum spar, bolted removable leading edge sections, sectionalized aft fairings bolted in place (Reference 4, Figure 18).
- o. As (n), but sectionalized aft fairings bonded in place (Reference 4, Figure 19).
- p. Two-piece extruded aluminum alloy spar, glass-fiber-reinforced-plastic aft skins, aluminum honeycomb core, glass-fiber-reinforced-plastic trailing-edge spline (Reference 5, Configuration I).
- q. Three-piece spar of stainless steel and aluminum sheet, aft section and spline as (p) (Reference 5, Configuration II).
- r. Glass-fiber- and carbon-fiber-reinforced-plastic spar, aft section and spline as (p) (Reference 5, Configuration III).
- s. Glass-fiber- and carbon-fiber-reinforced-plastic twin-beam spar, aft section and spline as (p) (Reference 5, Configuration IV).
- t. Spar as (s), integrally supported carbon-fiber- and glass-fiber-reinforced-plastic aft skin produced by pultrusion process, carbon-fiber-reinforced-plastic spline (Reference 5, Configuration VI).

- u. Spar as (p), pultruded integrally supported glass-fiber-reinforced-plastic aft skins, glass-fiber-reinforced-plastic spline (Reference 5, Configuration VI).
- v. Multispar construction utilizing a series of filament-wound glass-fiber-reinforced-plastic tubes enclosed in a filament wound glass-fiber-reinforced-plastic skin, with other structural and mass elements in the interstices between tubes (Reference 6).

Other possibilities, including variations of the 22 concepts above, include the following:

- w. As (v), with high-modulus fiber filament-wound skins for added torsional stiffness.
- x. Multicell structure formed from glass fibers or advanced fibers laid up on mandrels, loaded with resin, and cured in a mold. This type of construction can have many variations in materials used, fiber orientation, resin impregnation processes, final contour mold, and the proportion of automated procedures to manual labor.
- y. Combinations of metal structural members (spar and, possibly, spline) and molded reinforced-plastic contour. This hybrid construction can have as many variations as (x) above. (Reference 7 provides one example.)
- z. Various types of wooden construction, which may or may not incorporate metal or plastic.

#### FABRICATION CONCEPTS

The different methods of component fabrication used above can be divided into eight general groups: extruded metal, formed sheet metal, molded resin-impregnated glass or high-modulus fibers, molded wet laid-up fiber reinforced plastic, filament-wound fiber-reinforced plastic, precured resin-impregnated glass cloth, pultruded fiber-reinforced plastic, and carving to shape. Other fabrication techniques are possible, of course, and some of the component manufacturing methods applied above do not fall readily into any of the eight categories. The carved honeycomb (either metallic or organic) utilized by most of the above concepts, to support the aft skins, uses a technique which is otherwise applicable only to wood.

Of the methods of spar fabrication investigated, those produced by extrusion or pultrusion preclude variation of cross section along the span of the blade. These techniques are

not applicable to advanced-geometry blades which have tapered thicknesses, chord lengths, or otherwise changing contours, except where the extrusion is buried within a contour formed by other means. Sheet metal can be formed by stretching to tapered shapes, but if rolling is used, the same restrictions apply as to extrusion. All the molded concepts can have any desired contour configuration, and these, together with stretch-formed sheet metal, can be considered when advanced geometry is desired. The specific application of this program does not require variations in contour, but this limitation must be considered when the study results are generalized to include future Army helicopters of advanced aerodynamic performance.

Most of the concepts above have a basic blade section made up of individual components, preformed, precut, or precured, and bonded together in the final assembly operation. Concepts (v), (w), (x), and (y) above propose that the plastic be cured in the final mold, forming a one-piece structure. Some prebonded subassemblies, particularly for (y) where metal structural components are incorporated, may be used.

The sectionalized blades, (j) through (o) above, are assembled with a combination of adhesive and mechanical joints. The mechanical joints are designed for disassembly so that damaged sections of the blade can be individually replaced.

The root reinforcement hardware required to carry the blade retention loads into the hub is incorporated in several different ways. The most basic is that in which the additional strength necessary at the root is provided integrally with the spar as a local increase in the cross section. The stepped extrusion described in (d) provides an example, as does the spar shown in Reference 7. In the molded plastic construction methods, a possible solution is to bury sheet-metal laminae in the fiber and resin layup, providing the bearing strength necessary for the load paths to the retention pins. The most common solution, which adds manufacturing steps in itself but considerably simplifies fabrication of the basic blade section, is the use of external reinforcement consisting of upper and lower metal grip fittings, and usually sheet-metal doublers, to collect and concentrate the blade loads. This reinforcement may be installed by a bonding operation subsequent to the assembly of the basic blade, or at the same time in the so-called "one-shot" final bond. Other root retention concepts involve wrapping the reinforcing fibers of plastic spars around a strong metal structure, proposed for (v) and (w) above, and of wrapping the metal spar itself around a metal fitting, as in (m). Compatibility with a practical root retention is an important consideration in the choice of the basic blade section concept.

The attachment of the tip hardware is also a significant consideration. A tip closure must be provided, and balance adjustment provisions must be made, since the tip is the most effective accessible area for such an adjustment. Consequently, structural hard points must be available that are capable of carrying several pounds of mass in the very high centrifugal force field existing at the tip. This requirement does not present a serious problem in blades constructed with thick metal spars of relatively high bearing strengths, but the use of composite materials necessitates special, and often expensive, treatment of the tip configuration.

#### MATERIAL CHOICES

Material selections for concepts (a) through (z) above range from steel and titanium to organic honeycomb, foam, and wood. In structural applications, for spars and trailing-edge splines, metals have greater bearing strengths and shear stiffnesses than most fiber-reinforced plastics. These give an immediate advantage in the provision of root and tip attachment hard points, and for those blades where the spar forms a large torsion box, in torsional stiffness. However, reinforced composites generally display greater damage tolerance and therefore improved survivability, and may also provide better repairability. Wood has been used in the past for major structure because of its ease of shaping and its virtually limitless fatigue life at moderate stresses which results in conditional repair or replacement. Man-made materials are now preferred because woods vary considerably in density and strength within any given species, because wood is hygroscopic and absorbs and expels moisture depending on the ambient relative humidity if not well sealed, and because woodworking involves much hand work not suitable for series production. The availability of aircraft-grade lumber is limited and may become costly.

For the spar, repairability is a less important consideration than the technical requirements and the needs for damage resistance and tolerance. As was discussed in the design specification approach, the skill level and elapsed time limitations render structural repairs by replacement of highly stressed material undesirable, if not unsafe. With repairs limited to blending of nicks and scratches, the choice between metals and fibrous composites depends on other considerations, such as damage resistance, damage tolerance, structural requirements, and material and fabrication costs. Metals, in the thicknesses required for rotor blade spars, are generally more damage resistant (i.e., a given incident produces less damage) but less damage tolerant (i.e., a given amount of damage

produces a failure more quickly) than composite materials. Material costs generally favor metals, which range from aluminum as least expensive, to titanium, while composites range from E-glass-epoxy to boron, carbon, and high-modulus organic fibers. These two ranges have a wide overlap, so that E-glass-epoxy is considerably less expensive than titanium, for example. Fabrication cost depends on the proportion of automated processes to hand work, favoring extruded metal and filament-wound or pultruded composite materials. The primary technical consideration is that of torsional stiffness. High torsional stiffness, equivalent to that of the current UH-1H blade, is easily provided by a metal spar, even without significant contribution from the aft skins. The low shear modulus of the plastic matrix prevents the attainment of adequate shear stiffness with the fibers oriented parallel to one another, so that a significant proportion of the reinforcing fibers must be laid up at a large angle to the span axis. These fibers then contribute much less effectively to the bending stiffness and axial strength. Figure 2 shows the effect of fiber orientation on axial and shear stiffness, and shows that the latter can be achieved only at the expense of the former. High-modulus fibers will allow high stiffnesses in both senses, but at a considerable increase in cost.

Because of this torsional stiffness question, it appeared desirable to use a metal spar, because the program goals would not be directly affected by this material choice. If a composite spar were used, the risk would be introduced of the program's being diverted to technical development involving extensive dynamic analysis and testing, rather than developing the reliability and maintainability methodology. As techniques and materials are improved and reduced in cost, a blade of all-composite construction may become cost effective within the program guidelines, but at this time, further development is required. Although each of the candidates was examined in detail, this general consideration eliminated composite spars from further consideration.

Rotor blades manufactured entirely of nonmetallic materials may have a decided advantage in combat situations where detectability by enemy radar equipment presents a hazard. Metals reflect much more of the radar energy than do nonmetals, which are largely transparent to it. In any development program intended to achieve minimum detectability for a helicopter, the radar cross section of the blades must be considered, and the most direct approach is to eliminate metal components from the blade to the maximum extent possible. A more complex, but less effective, method is to hide any metal members (the spar, for example) behind radar-absorbing and attenuating material. However, this program does not have reduction of

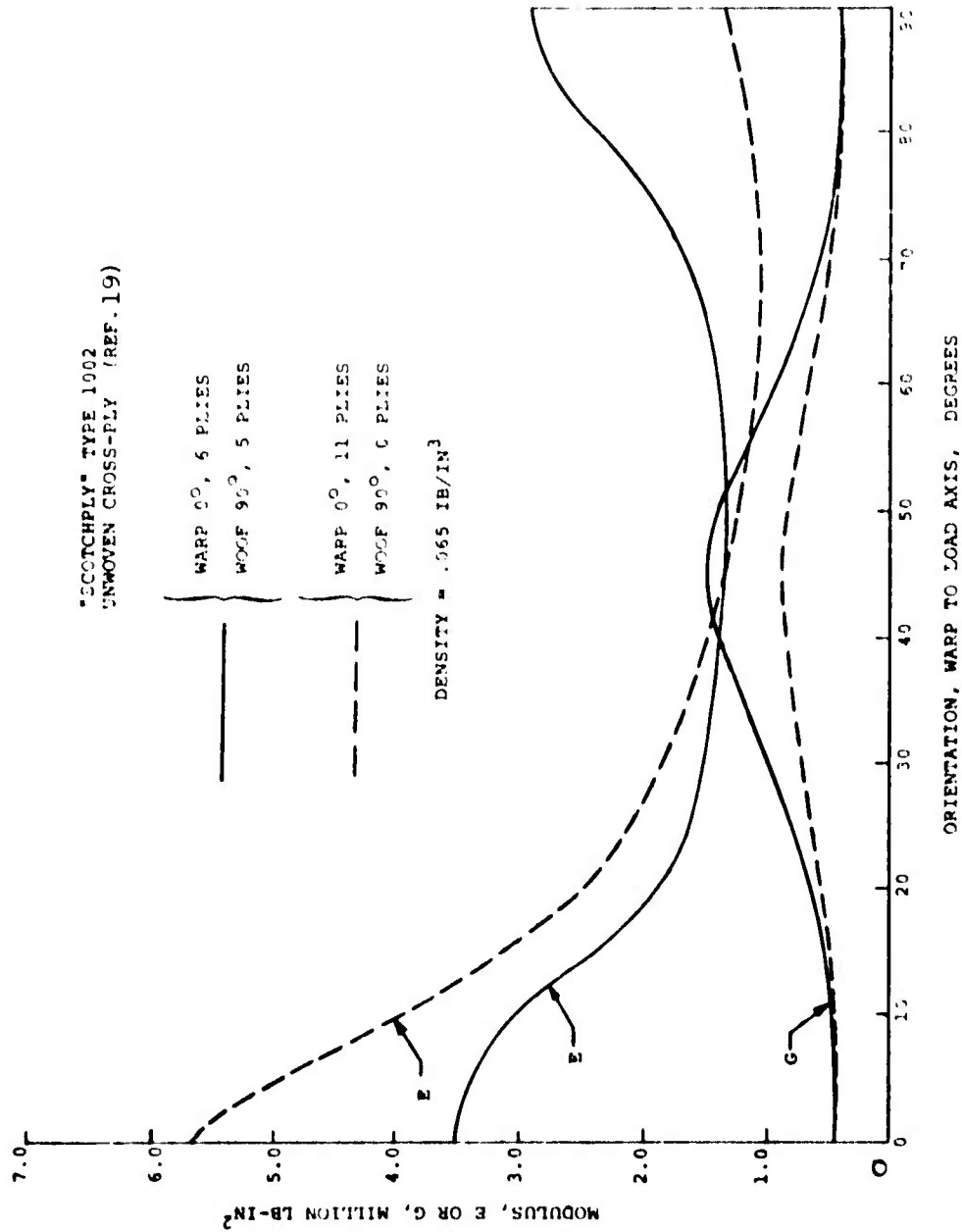

Figure 2. Modulus Variation With Fiber Orientation, Glass-Fiber-Reinforced Plastic.

detectability as a primary objective, the goal being the development of new techniques and methodology for improved maintainability and reliability, and reduced life-cycle costs. Requirements regarding both radar and acoustic detectability are therefore not major. With respect to radar detectability, the requirement is that the cross section be no greater than that of the current UH-1H blade. A similar requirement applies to acoustic detectability, so the ability to form exotic tip shapes is not needed. Since an improvement in these characteristics is not a program goal, the certainty that a metal spar can meet the structural requirements of torsional stiffness and root and tip attachments offers the minimum risk program and becomes the overriding consideration.

Because of the expendability criterion, the more expensive metals such as titanium were eliminated from consideration for the spar. Expensive operations, such as those involving extensive material removal, were also eliminated. The choice of spar material thus was narrowed down to extruded aluminum or formed stainless-steel sheet. Extruded aluminum has a cost advantage, while stainless steel is less susceptible to corrosion and abrasion. For equivalent strength and stiffness, the walls of the aluminum extrusion are about three times the thickness of the stainless-steel sheet, so that impact resistance favors aluminum.

With a metal spar whose outer surface forms the forward contour of the airfoil section, leading-edge protection needs to be provided only against sand and dust abrasion. Rain erosion has no significant effect on metal leading edges. Stainless steel itself is a satisfactory protective material, so that the stainless-steel sheet spar needs no added protection. The aluminum spar has thick walls which can withstand a large amount of material loss, particularly near the tip where most abrasion occurs, before becoming structurally hazardous, while the rate of weight loss is approximately equal to that of stainless steel. The dimensional material loss is approximately three times that of stainless steel, so that contour degradation may become a problem, causing a drop in aerodynamic performance. An aluminum spar may need to be protected against sand and dust abrasion for the last reason. Possible leading-edge protection materials include stainless steel, cobalt alloy, and polyurethane. The high-strength metal alloys have thermal coefficients of expansion such that special treatment must be used when bonding them to the blade so that built-in stresses and distortion do not occur during cooling. The thickness of the protective metal must be great enough that it does not wear through to the adhesive layer. If this occurs, the thin metal may peel back, with a result much worse than

unprotected aluminum. Current investigations indicate the possibility of replacing metal leading edges at the using unit level, but this concept is not as yet proven feasible, so the thickness must be sufficient to last for the full operational life of the blade. Polyurethane is impervious to sand abrasion, but it expands laterally under raindrop impact, creating shearing forces in the adhesive bond, which may fail. Increasing thickness of the polyurethane sheet reduces this effect, but it increases the centrifugal load per unit area of adhesive. These effects make it impossible to ensure survival of a polyurethane abrasion sheath for the full operational blade life, so the adhesive must be selected so that the sheath can be stripped and replaced in the field before complete failure of the bond.

The aft skins and core are secondary structure and, because they comprise more than half the planform area of the blade, suffer the majority of the damage, particularly that defined in the damage scenario. Consequently, the aft skins must be designed to have maximum repairability. Thin metal skins cannot be patched readily, without creating stress concentrations both at the edges of the patch and the edges of the hidden damage. The potential for further failure cannot be avoided. On the other hand, experience with patches on fiber-reinforced-plastic skins has been good, both because of the relatively low modulus and therefore low stresses, and because of the slow crack growth rates. Weight for weight, reinforced plastic is thicker than aluminum, so its impact resistance is enhanced. In all-composite blades, the skin cannot be treated quite so simply, because the skins will carry a greater proportion of the blade loads, particularly if the aft section is required to contribute significantly to the torsional stiffness. The total area which may be patched before appreciable structural degradation occurs will be reduced compared to designs using aluminum or steel primary structure. Skins using high-modulus fibers have been proposed, but experience to date indicates high cost and apparently low impact resistance. A filament-wound composite skin using a high-modulus organic fiber (PRD-49) is under development, and shows promise of extremely high abrasion resistance and good impact resistance, as well as contributing the torsional stiffness lacking in all-composite primary structure. The cost increase is moderate, at approximately \$500 per skin set.

For the aft core, the plastic foams so far developed are unsatisfactory in the densities acceptable for use in the aft section. Under the continual periodic flexing of the blade, these materials tend to break up. Balsa wood can be used, but it suffers from the deficiencies outlined above for woods in

general. The remaining choices are various forms of bonded honeycomb made from either thin aluminum alloy sheet or polyamide paper. The latter is slightly more expensive, but it is easier to work, reducing scrap and fabrication costs, and is more resilient, so equal damage to the skin results in less damage to the polyamide core than to the aluminum core. Because of its resilience and ease of handling, polyamide paper can be used in densities lighter than aluminum foil, easing the design constraints from balance requirements on the blade as a whole. Unless impermeably sealed, aluminum foil is subject to corrosion, which does not affect the non-metallic paper. Metal foil inside nonmetal skins is an unfavorable combination in the event of a lightning strike, since the foil may explode, causing severe damage. The polyamide paper, being a nonconductor as well as the skins, merely melts. For all these considerations, the choice of an aft section core material is limited to polyamide paper honeycomb at its lowest available density.

Since these blades must fly on a two-bladed teetering rigid-in-plane rotor, the in-plane natural frequencies and therefore stiffness are of prime importance. The trailing-edge spline is a primary structural member, subject to the same repair limitations as the spar. The choice of spline material is dictated by technical and manufacturing considerations. Ideally, for compatibility of thermal contraction after bonding, the spline should be of the same material as the spar. This is satisfactory with aluminum, but a steel spline would be too small outboard to provide adequate surface area for bonding to the skin. Hence with a stainless-steel spar the spline will be of unidirectional glass-fiber-reinforced plastic, whose thermal coefficient of expansion is close to that of stainless steel. These combinations, aluminum with aluminum and stainless steel with unidirectional glass-epoxy, will avoid the necessity for straining components during final assembly to avoid locking stresses in during cooling.

#### PRELIMINARY EVALUATION AND FURTHER SELECTION

Concepts (a) through (z) above have been examined with respect to the reliability, maintainability, cost, and technical characteristics of fabrication techniques and materials. Individually, these preliminary evaluations are listed below.

- a. This concept is a compromise arrived at in the design study of Reference 2, and it represents the most cost-effective approach to a repairable blade.

- b. The best feature of this concept, the reinforced plastic aft skins, was incorporated in (a).
- c. The titanium spar increases the repairable area, but it adds unacceptably to the cost.
- d. This concept has characteristics similar to those of (a), but the stepped extrusion providing the root end integral with the spar is more expensive than the laminated buildup.
- e. The composite material makes the spar unacceptably costly, according to the analysis of Reference 2, and the torsional stiffness is questionable.
- f. This concept is the least expensive of the expendable blades, but the aft section is neither damage resistant nor very repairable.
- g. This blade concept gave the lowest life-cycle costs of the four studied in Reference 3, but subsequent study showed that the stainless-steel spar was priced unrealistically low, and that the basic advantages lie with the repairability of the aft section, although the rugged spar is a contributor.
- h. The chord-plane shear web is attractive because of its anticipated reduced vulnerability. However, the extra pair of glue lines and the third sheet of material mean that the external skins have to be very light to maintain section balance. Through damage is unrepairable.
- i. The thin-walled extruded aft section is extremely expensive, if not impossible to obtain.
- j. In common with the other sectionalized blades, the necessity for providing a solid trailing-edge spline, for in-plane stiffness, forces the cost of the removable aft section pockets and the accompanying fastener provisions to go so high that the concept is not cost-effective.
- k. Again, the sectionalized approach is not cost-effective, and the all-glass-fiber-reinforced-plastic construction may give difficulty in meeting dynamic requirements.
- l. This concept was abandoned from the study in Reference 4 because of its complexity.
- m. In addition to the inherent disadvantage of the sectionalized approach, a seamless tube more than twice the length of the blade is currently impractical.

- n. Although simplified from (j), this version of the section-  
alized blade is not cost-effective.
- o. Using bonded attachments, the cost and complexity of the  
blade are reduced, but the replaceability of the aft boxes  
suffers to the extent that (n) is preferred.
- p. This concept is similar to (a), but the spar can be a one-  
piece extrusion to reduce cost, while the degree of re-  
pairability available at the spline does not justify the  
use of fiber-reinforced plastic.
- q. The acquisition cost of the three-piece sheet-metal spar  
is slightly higher than that of (p), while the vulner-  
ability and repairability remain approximately the same.
- r. The cost and torsional stiffness objections to a composite  
spar apply to this blade, although Reference 5 suggests  
that costs will become competitive by 1980.
- s. Again, the cost and stiffness questions do not appear to  
be adequately answered.
- t. The pultrusion process, when fully developed, may reduce  
costs, while the use of high-modulus carbon fibers in the  
skin may provide adequate stiffness. These developments  
are not expected during the time frame of this program.
- u. This is similar to (p) in characteristics, and the pul-  
truded skins may reduce costs sufficiently to offset the  
anticipated increase in spar extrusion costs. Again,  
this is a future development not ready for this program.
- v. This is a very interesting concept because of its evident  
survivability after ballistic damage. However, the  
torsional stiffness is inadequate, and the design of the  
root retention must be complex and expensive because of  
the necessity for attaching a multitude of basic struc-  
tural members. Through damage is probably unrepairable  
because almost all of the planform encloses primary  
structure. The unusual internal configuration would  
require special tools for patch procedures. The filament  
winding process is highly automated and inexpensive,  
so the basic blade section is relatively inexpensive,  
but the costs of the root and tip must yet be defined.

- w. The use of high-modulus organic fiber in the skins restores adequate torsional stiffness, as well as increases damage resistance. However, development of this concept has not yet progressed to a point where the basic goal of the program, that of determining reliability and maintainability design methodology, can be met with the certainty that an extensive technology development diversion can be avoided.
- x. The varieties of this concept all leave the basic torsional stiffness concern unanswered. Material costs are higher than those of aluminum, although it is possible that automatic processing can reduce fabrication costs.
- y. The metal structural members provide hard points at root and tip, and add torsional stiffness, but the production cost adds that of the metal-forming technique to that of the fiber impregnation, layup, and cure. This may be a relatively inexpensive and reliable way to achieve advanced geometry in the near future.
- z. The objections to wood in series production have been outlined above.

In the light of the foregoing evaluation of possibilities, the selections of materials and fabrication techniques became as follows:

Spar: Extruded aluminum, or stretch-formed stainless-steel sheet to provide the possibility of advanced geometry.

Leading-Edge Abrasion Protection: Bare metal, or removable/replaceable polyurethane.

Leading-Edge Ballast: Integral with the spar.

Aft Skins: Glass-fiber-reinforced plastic, or high-modulus organic-fiber-reinforced plastic, with fibers oriented for shear, rather than axial, stiffness.

Aft Core: Polyamide paper honeycomb.

Trailing-Edge Spline: Extruded aluminum with the aluminum spar, or unidirectional glass-fiber-reinforced plastic with the stainless-steel spar.

Root Reinforcement: Built-up laminations, with materials selected for compatibility with the basic blade.

## SELECTED DESIGN APPROACHES

From the foregoing discussion and evaluation, twelve different design variations were selected for further investigation. Detail drawings, manufacturing cost estimates, technical analyses, operational analyses covering failure predictions and maintainability estimates, repair schemes, and life-cycle costs were developed for these concepts. For some of these analyses, the twelve concepts could be divided into fewer subgroups in which all the design features relevant to a particular analysis were alike. However, each of the twelve concepts represents a different combination of manufacturing cost, reliability, repairability, and technical characteristics.

The significant design features of the twelve concepts, together with their unit prices estimated both for mid-1971 and mid-1976, are presented in Table I. Figures 3 through 9 present the general arrangements of the basic families of these concepts, and typical sections through their respective structures.

### CHOICE OF FABRICATION TECHNIQUES

Standard industry practice uses adhesive bonding to assemble the blade. As developed over the years, this has become by far the most widely used method of obtaining a reliable rotor blade. Stress raisers, such as are created by mechanical fasteners, are avoided, an essential feature of any structure intended to operate in a high-fatigue-loading environment. Other methods of joining, such as brazing, soldering, and welding, have been used, but structural adhesives have now been developed to a point where the other methods show no advantage. Utilizing contractor and general industry experience, adhesive bonding will be used throughout the blade.

Methods of fabrication of major structural details are crucial in determining the blade price. For the main spar, which the previous section shows should be metal, the choices of forming methods are extrusion, rolling, or stretch-pressing. Of the three, the first is the least expensive, while the third provides the only opportunity to vary the section shape along the span. Because of the tolerance on blade twist, the full cost advantage of extrusion is not realized, because the solid spar must be twisted, in a stretch press, before bonding. Sheet-metal spar components, and all the other spanwise blade components, have little torsional stiffness, so the final bonding fixture will set the twist, which becomes locked in when the torsion cells are closed. However, an extruded

TABLE I. DESIGN CONCEPTS EXAMINED

Concept	Airfoil Section	Abrasion Sheath	Materials and Forming Processes					Price (\$)	
			Main Spar	Aft Skin	Aft Core	T E Spline	Root Doublers	Mid-1971	Mid-1976
1	Modified } 12% } NACA } 0012 }	None	6061	Glass-Fiber	Polyamide	6061	2024	2,815	3,659
2			Al. Alloy	Reinforced	Paper	Al. Alloy	Al. Alloy	Sheet	2,888
3	Modified } 12% } NACA } 0012 }	None	AISI 301	Glass-Fiber	Polyamide	Unidirectional	AISI 301	3,765	4,926
4			St. Steel	Reinforced	Paper	S-Glass	St. Steel	Sheet	3,839
5	Modified } 12% } NACA } 0012 }	None	AISI 301	Glass-Fiber	Polyamide	Unidirectional	AISI 301	3,581	4,666
6			St. Steel	Reinforced	Paper	S-Glass	St. Steel	Sheet	3,654
7	Modified } 12% } NACA } 0012 }	None	6061	Glass-Fiber	Polyamide	6061	2024	2,840	3,691
8			Al. Alloy	Reinforced	Paper	Al. Alloy	Al. Alloy	Sheet	2,913
9	Modified } 12% } NACA } 0012 }	None	6061	Glass-Fiber	Polyamide	6061	AISI 301	2,838	3,688
10			Al. Alloy	Reinforced	Paper	Al. Alloy	St. Steel	Sheet	2,911
11	Modified } 12% } NACA } 0012 }	None	6061	PRD-49 Fiber	Polyamide	6061	2024	3,315	4,159
12			Al. Alloy	Reinforced	Paper	Al. Alloy	Al. Alloy	Sheet	3,388
Current UH-1H Blade	NACA 0012	St. Steel & Cobalt Alloy	5-Member Steel/Al. Box Beam	2024 Al. Alloy Sheet	Aluminum Honeycomb	2014 Al. Alloy Extruded	2024 Al. Alloy Sheet	3,000	--

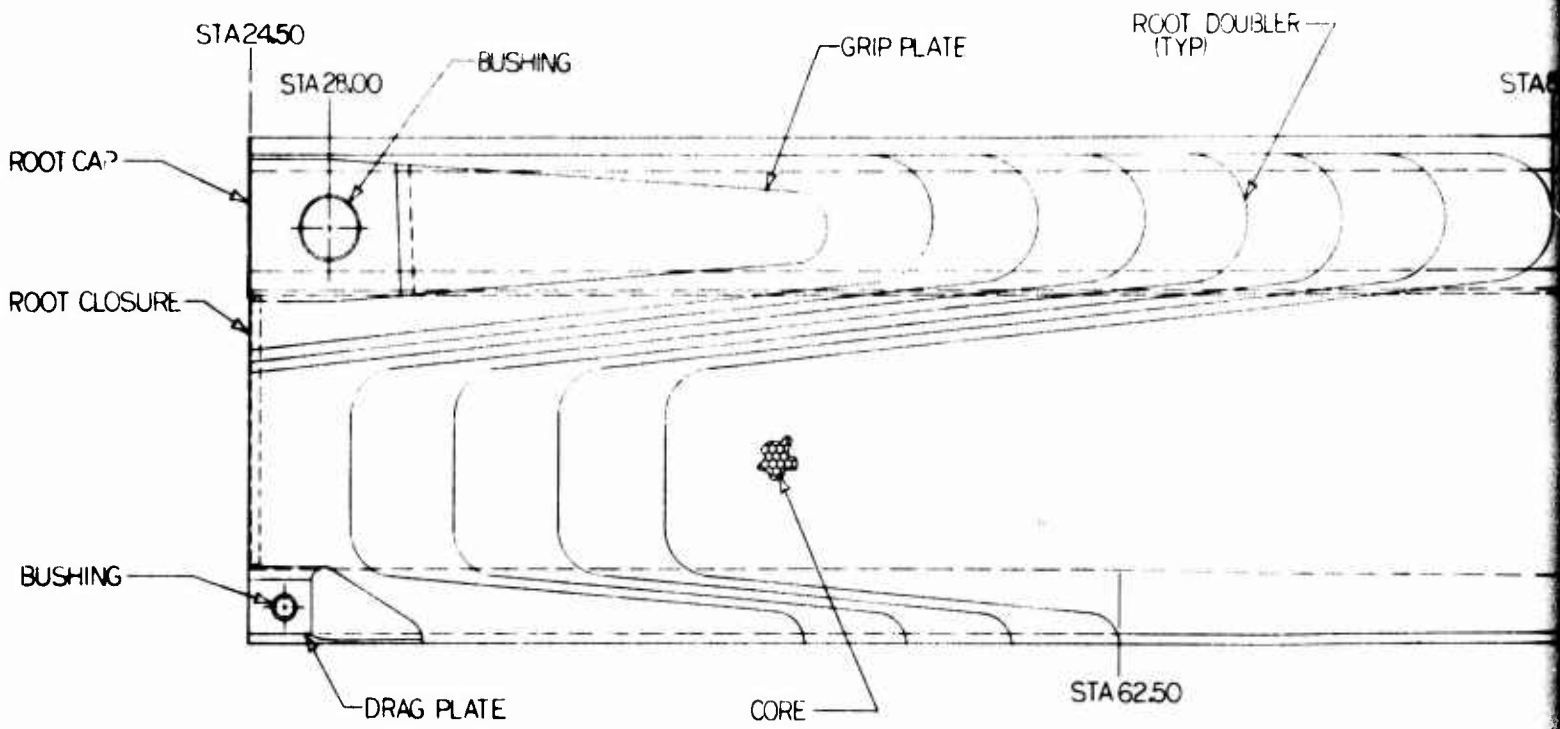

Figure 3. Concept 1.

OT DOUBLER  
YP

STAB1.00

SPAR

UNIDIRECTIONAL  
GLASS CLOTH  
SKIN (4 PLIES)  
120 GLASS CLOTH  
CORE

SKIN BUILDUP  
ENLARGED VIEW

TE SPLINE

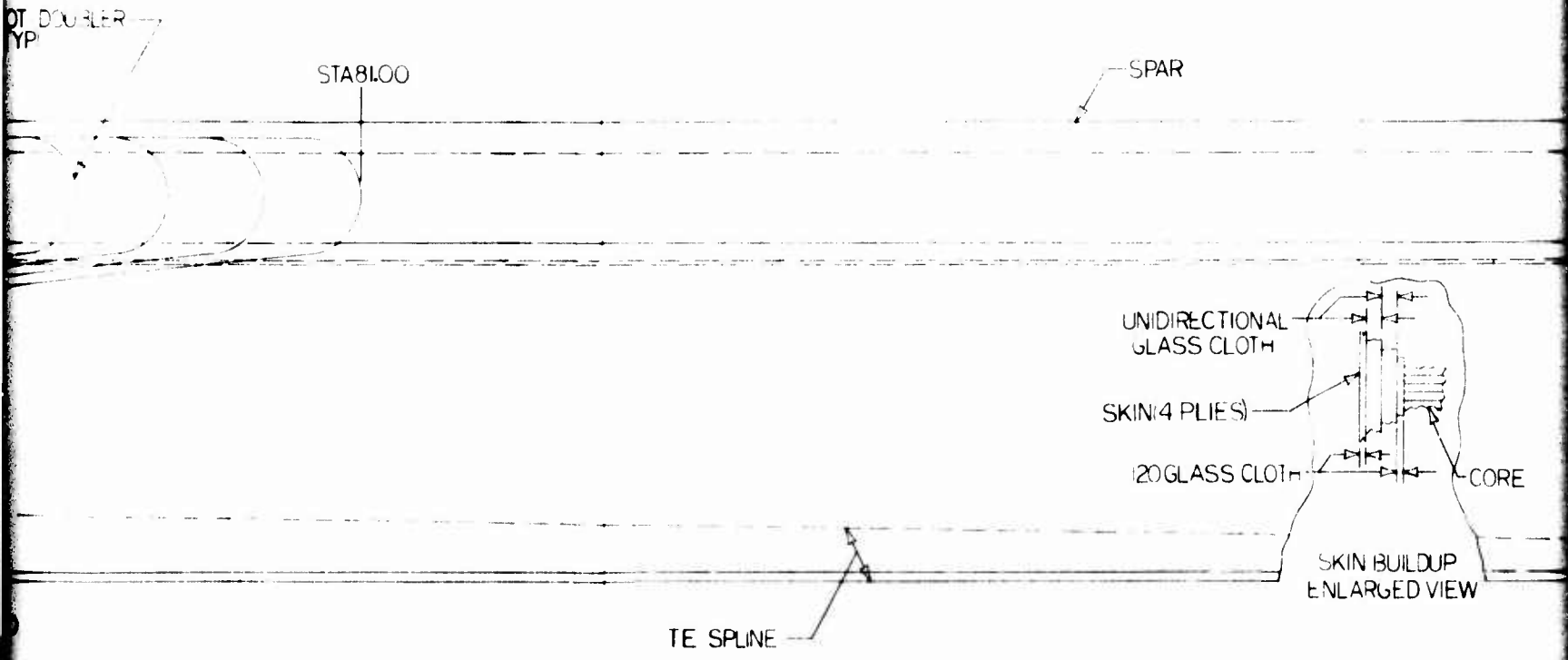

SPAR

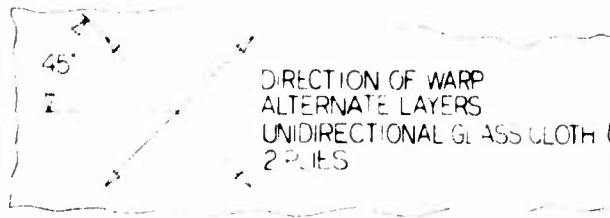
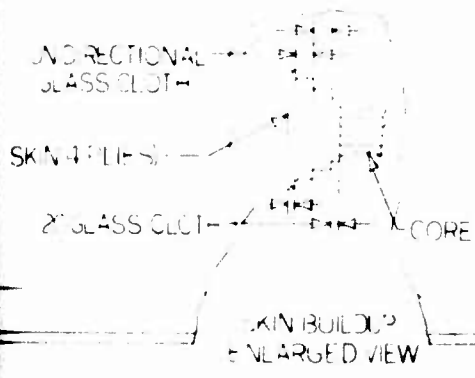

DIRECTION OF WARP  
12" GLASS CLOTH

SKIN

→  
DIRECTION OF WARP  
ON MASS CLOTH

STA 21000

TRIM TAB



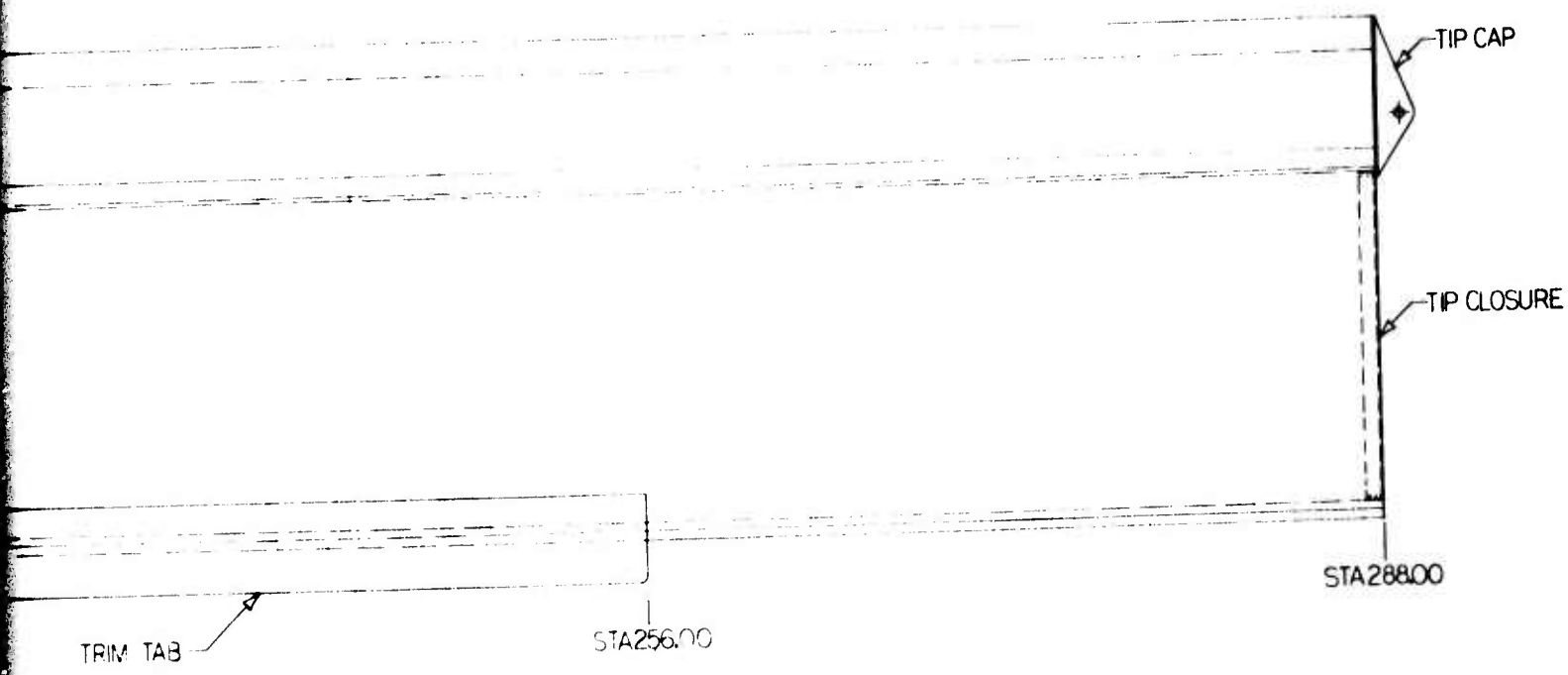

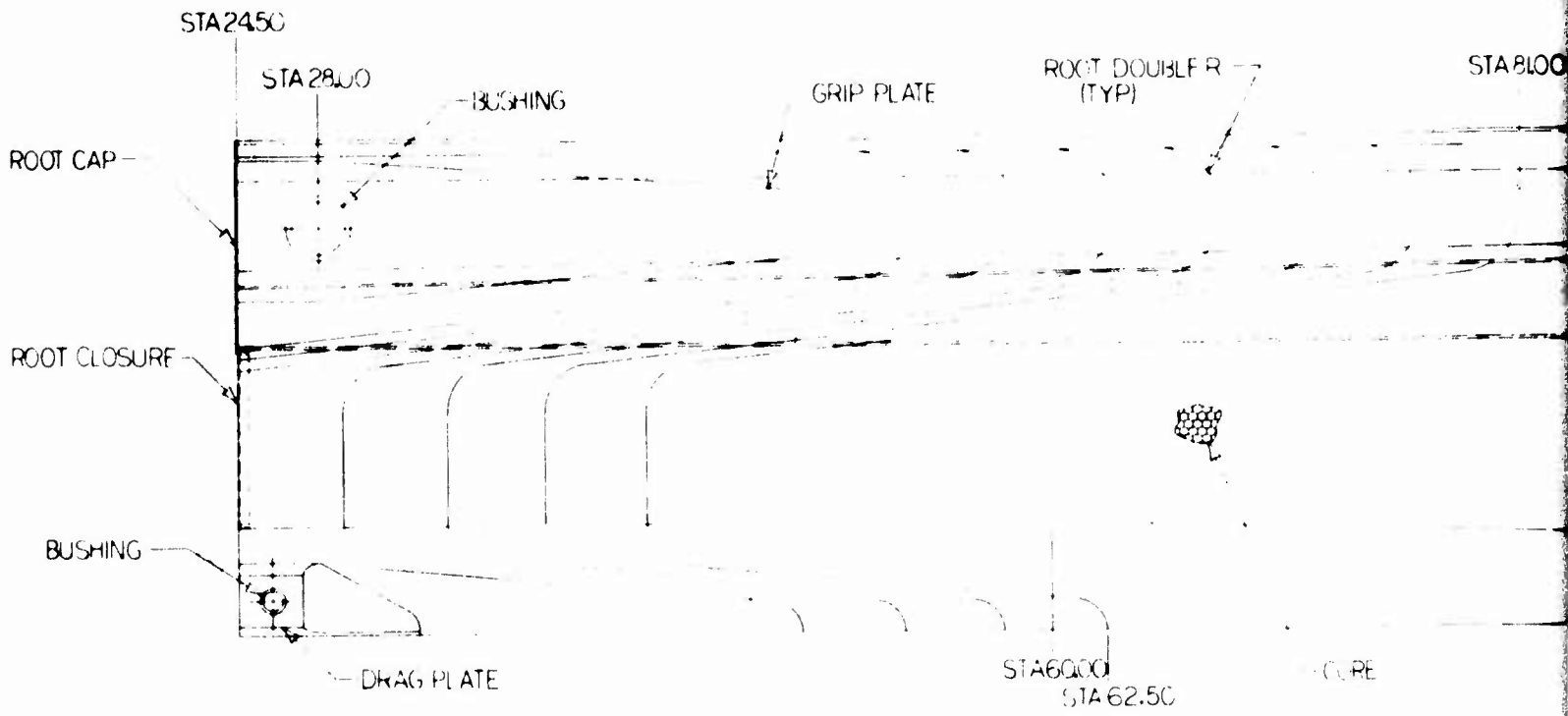

Figure 4. Concept 3.

STA 8100

NOS SKIN

UNIDIRECTIONAL  
GLASS CLOTH  
SKIN 4 PLYS  
120 GLASS CLOTH

CORE

AFT SKIN BUILDUP  
ENLARGED VIEW

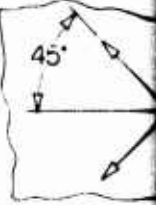

1000000



SKIN BUILDUP  
ENLARGED VIEW



DIRECTION OF WARP  
ALTERNATE LAYERS  
UNIDIRECTIONAL GLASS CLOTH  
2 PLYS

DIRECTION OF WARP  
120 GLASS CLOTH

AFT SKIN

TOOLING TAB  
181 GLASS CLOTH

SPLINE  
ENLARGED VIEW



AF

FORWARD CHANNEL

AFT CHANNEL

NOSE WEIGHT

UNIDIRECTIONAL  
GLASS CLOTH TYPE

AFT SKIN

STA 21000

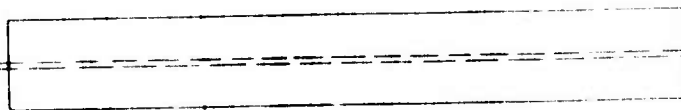

TRIM TAB

STA 256.00

VIEW

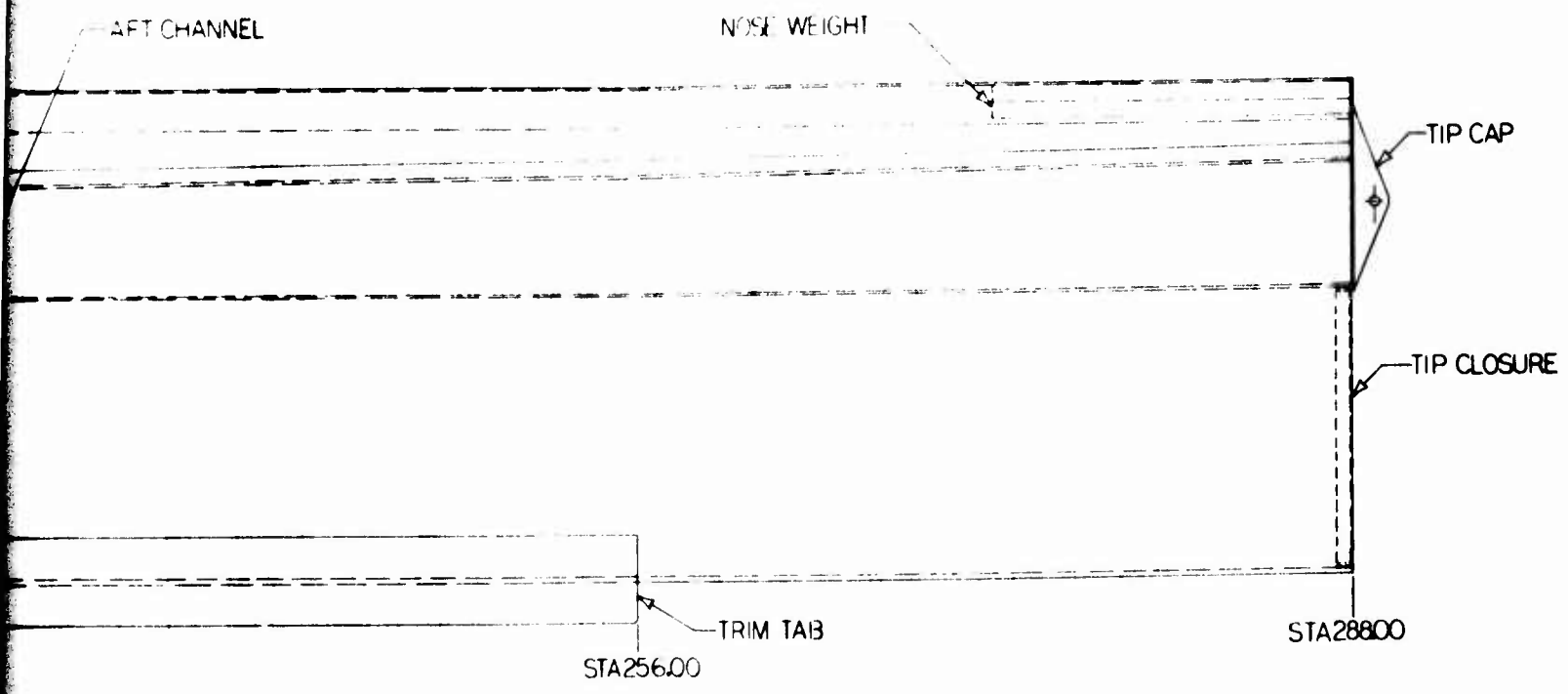

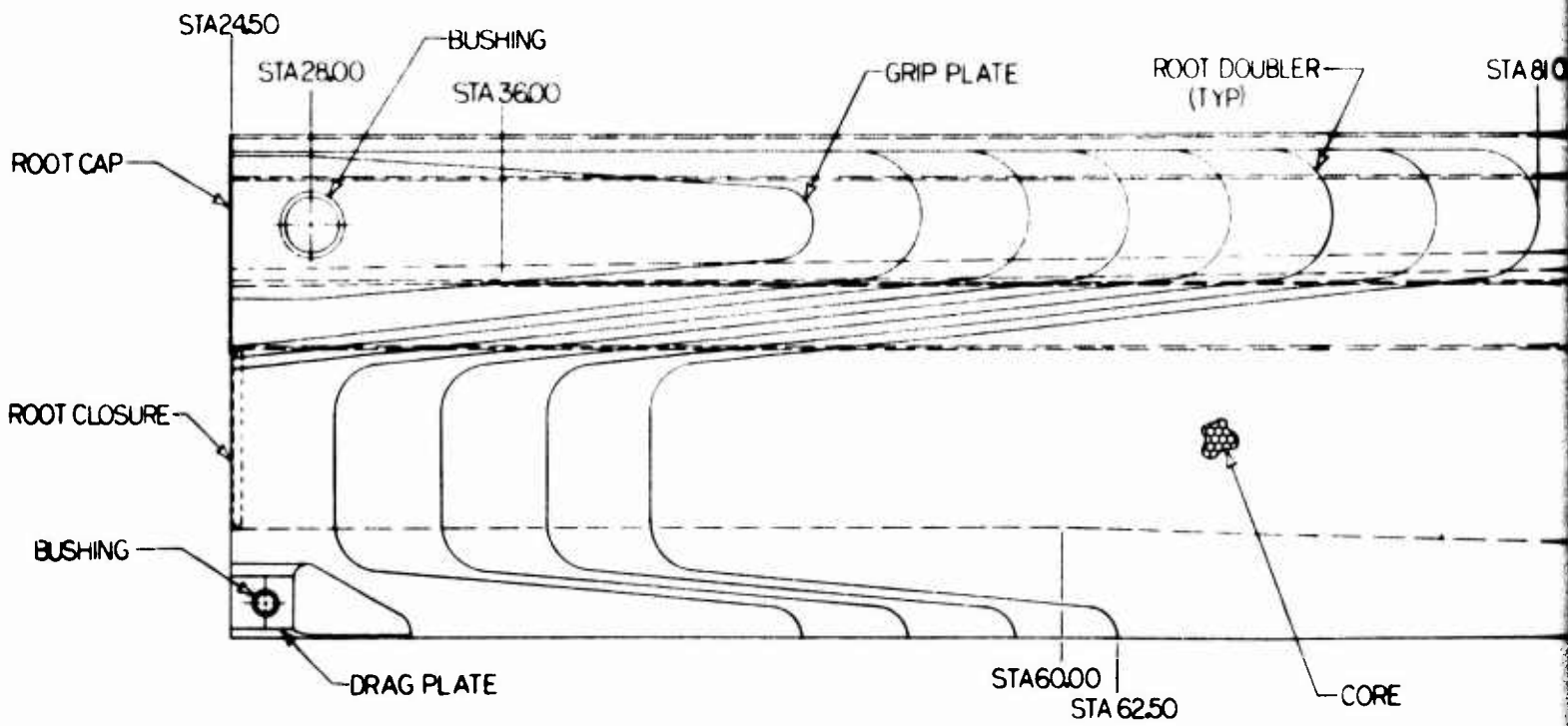

Figure 5. Concept 5.

STA 8100

FORWARD CHANNEL

UNIDIRECTIONAL  
GLASS CLOTH  
SKIN 4 PLIES  
120 GLASS CLOTH  
CORE

DIRECTION OF WARP  
120 GLASS CLOTH

45°

AFT SKIN BUILDUP  
ENLARGED VIEW

TE SPLINE

AFT SKIN

RE

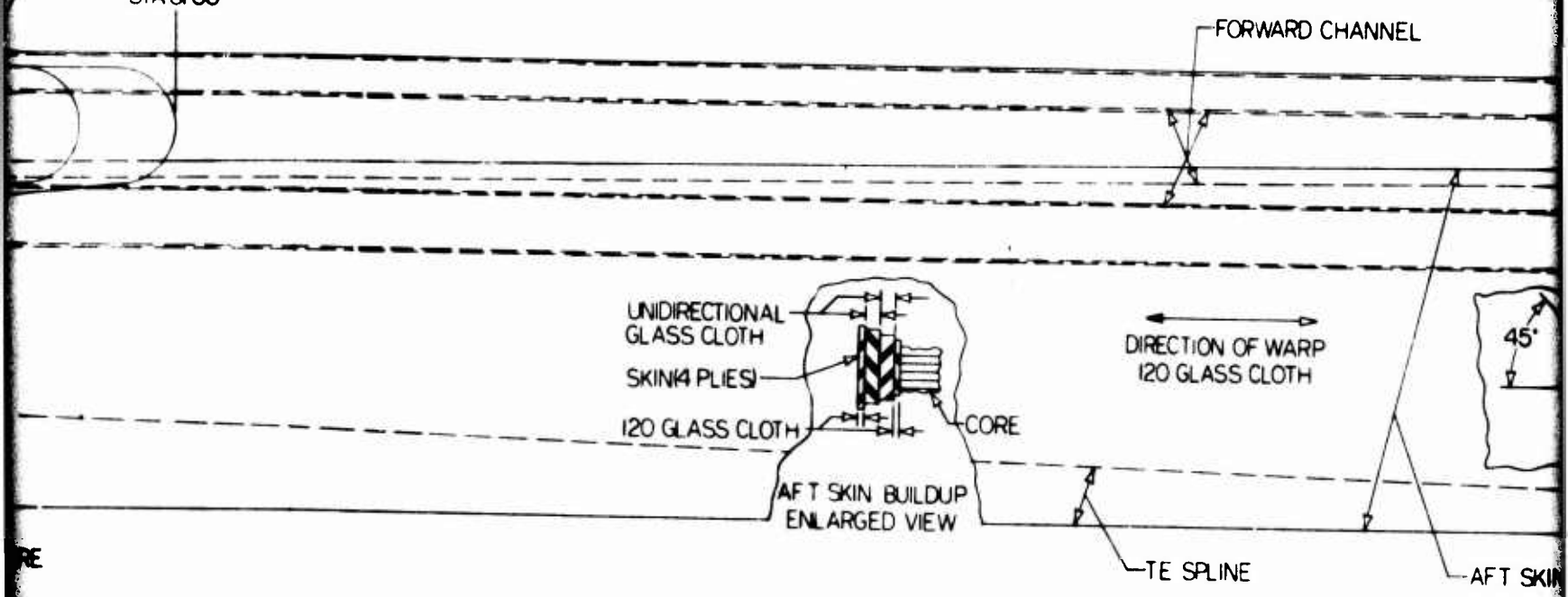

FORWARD CHANNEL

STA 177.00

NOSE SKIN

WARP  
DEPTH

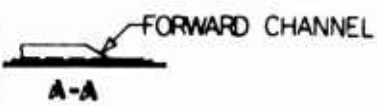

UNIDIRECTIONAL GLASS CLOTH

AFT SKIN

TOOLING TAB  
181 GLASS CLOTH

AFT SKIN

TE SPLINE  
ENLARGED VIEW

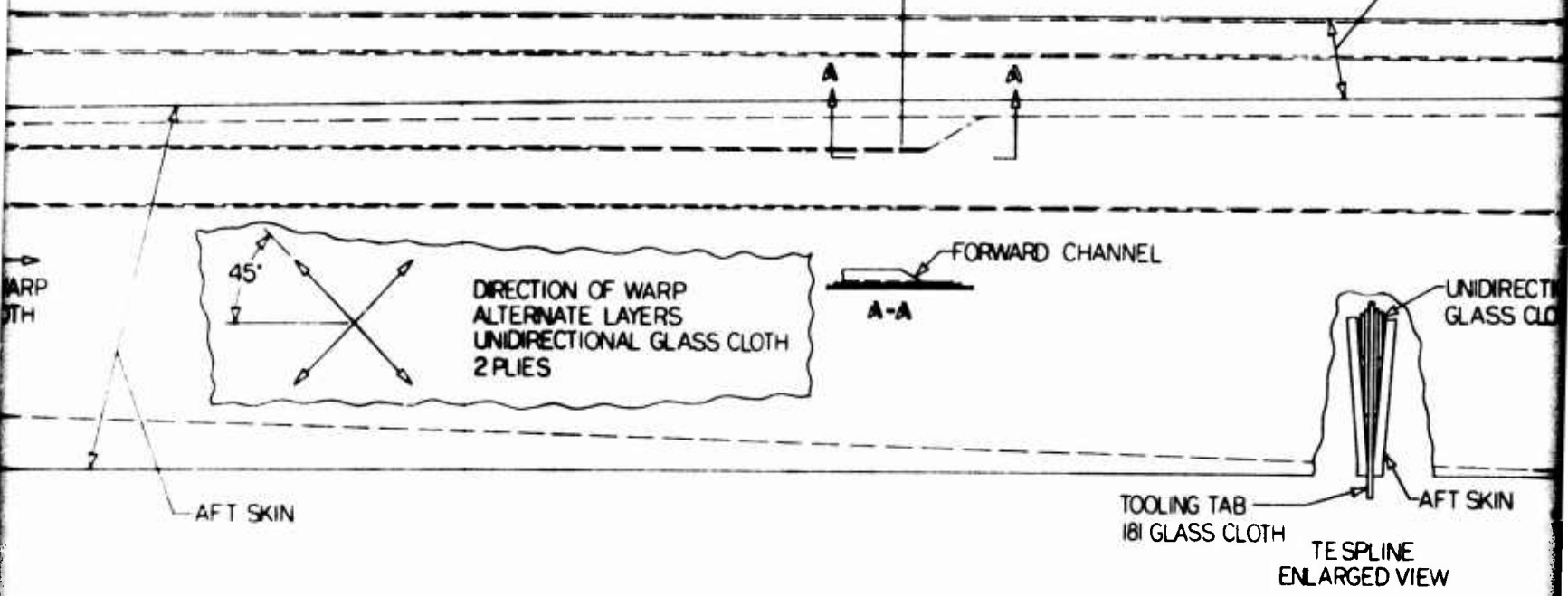

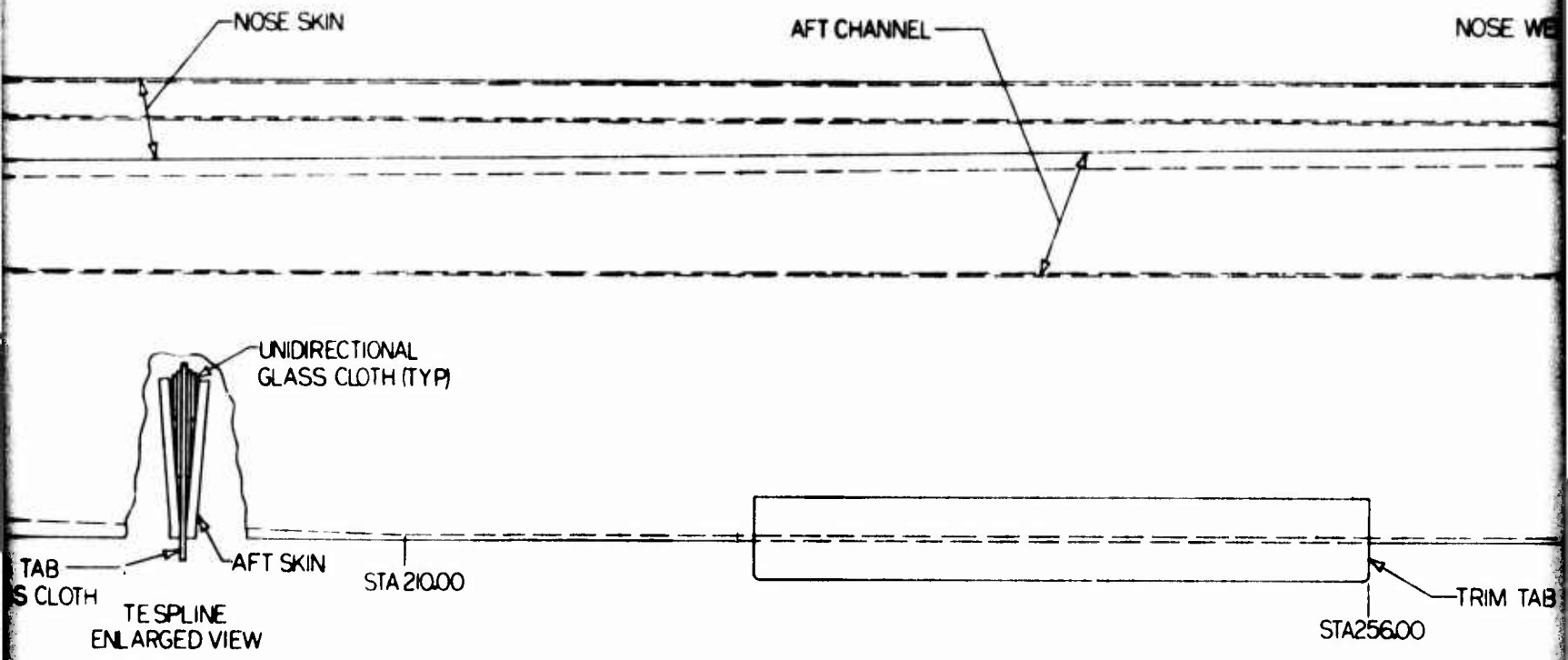

AFT CHANNEL

NOSE WEIGHT

TIP CAP

TIP CLOSURE

TRIM TAB

STA25600

STA28800

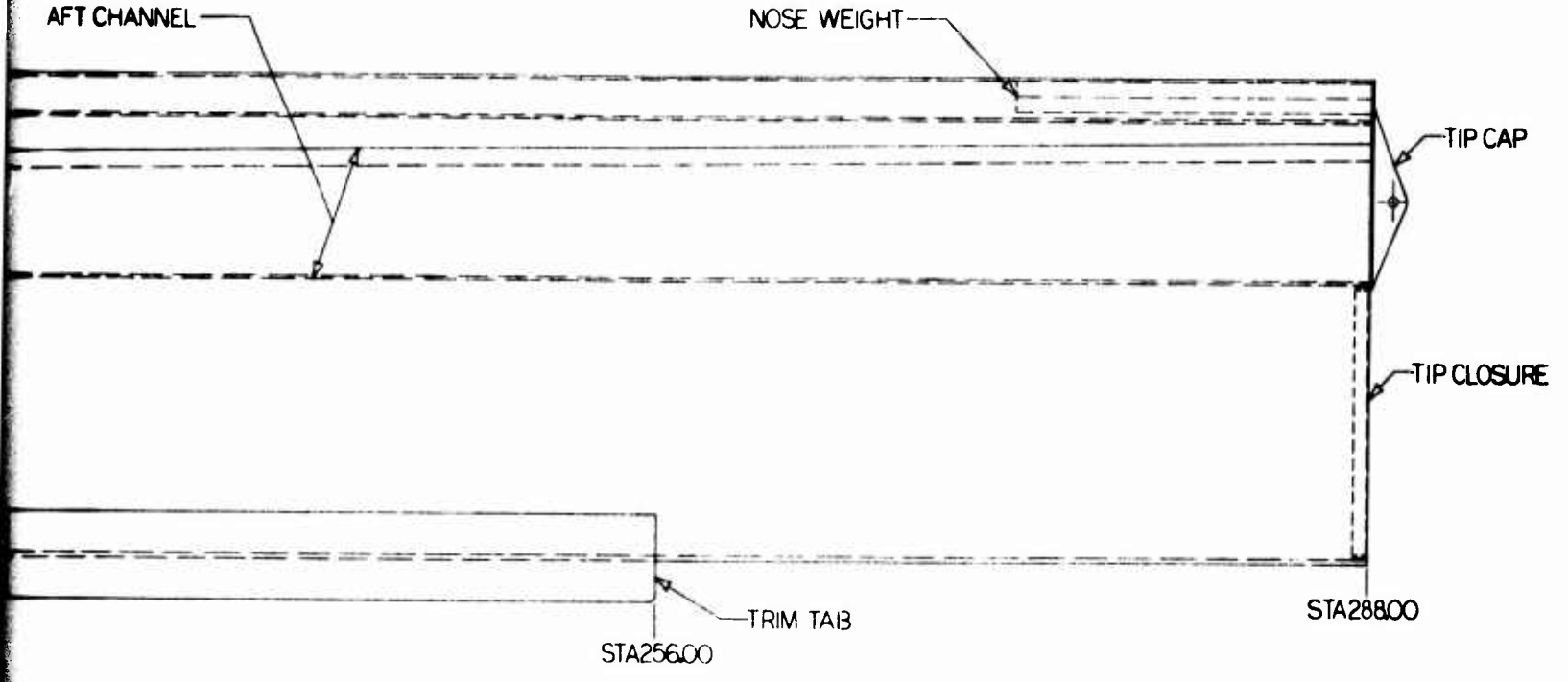



DESIGN 1

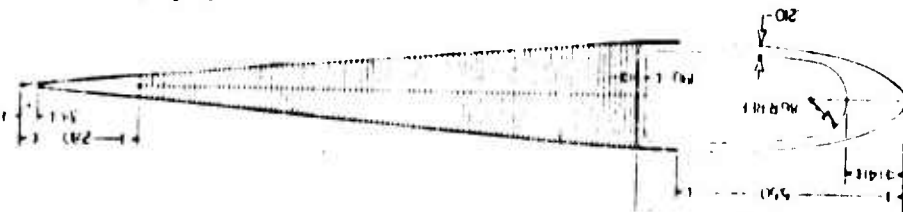

DESIGN 1

Preceding page blank



DESIGN 2

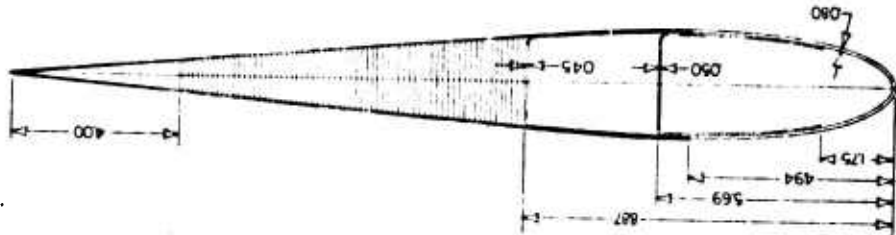

DESIGN 3

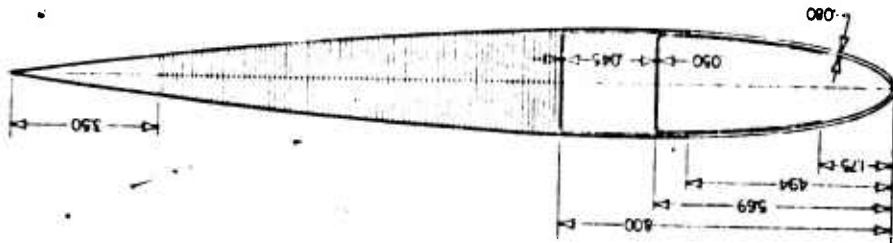

DESIGN 4

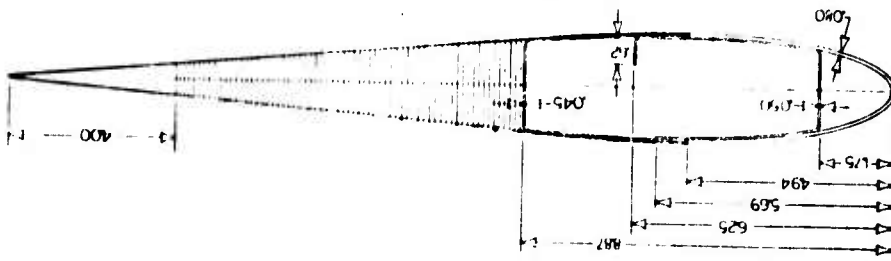

DESIGN 5

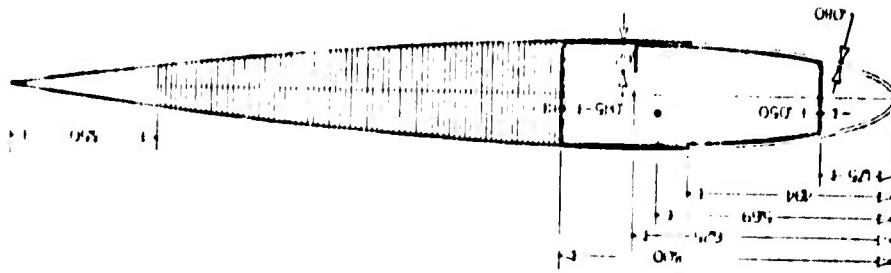

DESIGN 6

Figure 7. Blade Sections at Station 81.0.

DESIGN 6

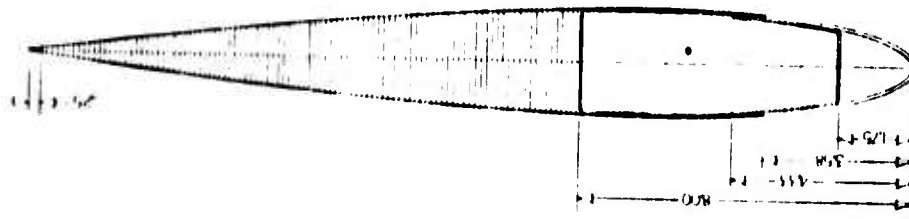

DESIGN 5

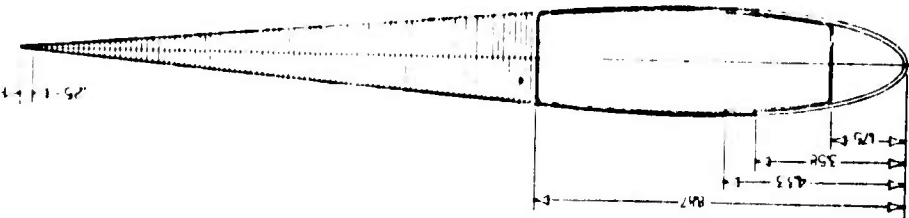

DESIGN 4



DESIGN 3

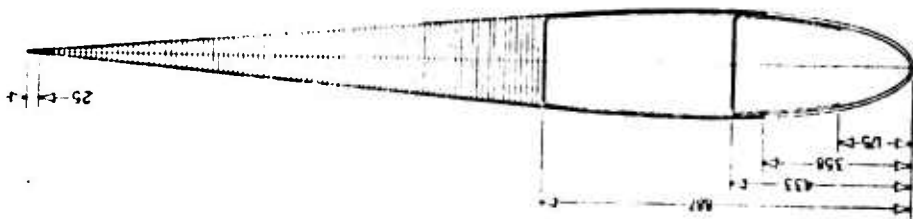

DESIGN 2



DESIGN 1



Preceding page blank

Figure 8. Blade Sections at Station 210.0.

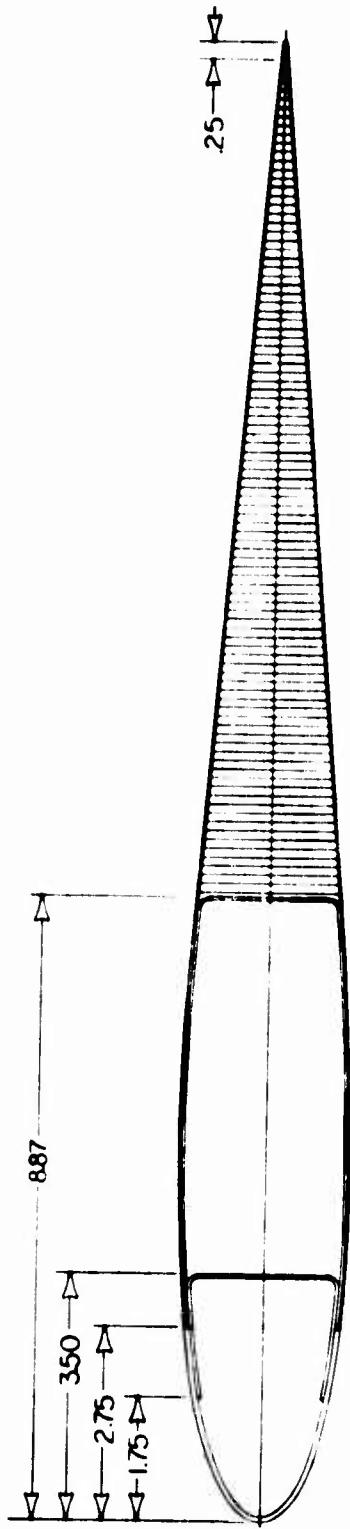

DESIGN 3

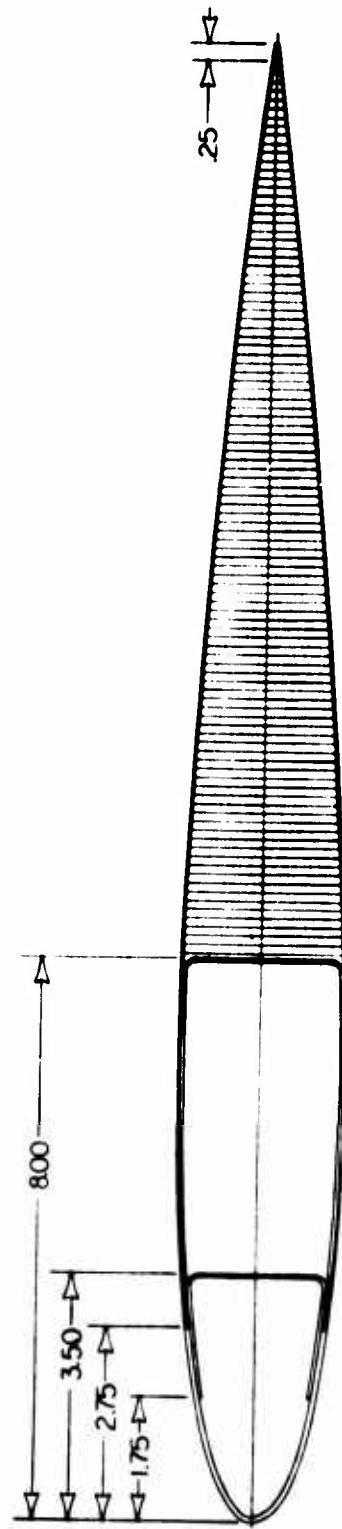

DESIGN 4

SECTIONS AT STA 288.0

Figure 9. Blade Sections Extrapolated to Station 288.0.

Preceding page blank

aluminum spar retains a cost advantage over stainless-steel sheet.

For the remaining blade components, the discussion in the previous section has eliminated most options. The skins will be precured, the core will be carved to contour (one or both sides) by standard techniques, and the trailing-edge spline will be either extruded and machined, or molded to shape.

A choice of fiber layup methods for the skin is available, using either preimpregnated cloth or filament winding. The latter is suggested for use with advanced fibers, where the availability of preimpregnated fabrics is limited. Filament winding is a highly automated procedure which shows promise of reducing the cost of skins using any fiber, including glass, in future applications.

The root reinforcing doublers should be designed so that they all have the same outboard planform so that costs can be saved by routing them as a stack, or stamping them out with a single blanking die. In large quantity production this advantage is small, affecting primarily the nonrecurring costs, but the technical advantage of using dissimilar planforms is negligible. Thick aluminum doublers will have to be formed to contour before bonding, because the bonding pressure will not be enough to bring them down and the locked-in stresses in the adhesive layers would be undesirable, but the relatively thin stainless-steel doublers will drape to the contour under light pressure.

#### CHOICE OF MATERIALS

The choices of fabrication processes and of materials cannot be made independently of one another, and the general selections of both were made in the discussion above. However, the choices of specific alloys, adhesive formulations, glass fabrics, and other details must be made to conform as closely as possible with the requirements of the design specification and fabrication techniques.

For the extruded spar, 6061 alloy in the T651 condition (solution heat-treated and artificially aged, stress-relieved by stretching) is selected. This alloy has relatively low yield and ultimate strength, but it is one of the most easily extruded alloys, has good fracture toughness, and has a fatigue endurance limit comparable with that of the harder alloys. Its resistance to environmental and stress corrosion compares favorably with that of other commonly used aluminum alloys.

For the sheet metal spar, AISI 301 stainless steel was chosen, primarily because of the considerable backlog of industry experience in the use of this alloy for helicopter rotor blades. The sheet would be procured in the  $\frac{1}{2}$ -hard to  $\frac{3}{4}$ -hard condition, the hardness being determined by the necessity to form the minimum bend radii. The strength will increase locally due to work-hardening during forming, but the yield and ultimate strengths remain low in comparison with other steels. 301 alloy is one of the most successful materials used for corrosion and abrasion protection of rotor blades, exhibits good fracture toughness, and has good fatigue strength provided the sheet edges are carefully treated to eliminate microscopic machining cracks.

Both of these choices of spar material exhibit low yield and ultimate strengths in comparison with other alloys of the same base metals, but because the design concepts use a relatively heavy spar to provide chordwise section balance, static stresses are low. Other design criteria become dominant.

For the aft skins, the primary choice is preimpregnated glass fabric. For shear stiffness, a major proportion of the glass fibers have to be laid up at  $45^\circ$  to the blade axes. Glass fibers are available in two grades, E and S, the latter having higher modulus and strength but considerably higher cost than the former. The cost difference was much more significant than the structural advantages, in the context of this program, so E-glass was chosen. The basic structure of the skin consists of two layers of unidirectional glass fabric laid up perpendicular to each other and at  $\pm 45^\circ$  to the blade span axis. These layers are each .0075 inch thick for a combined thickness of .015 inch. The two unidirectional layers are sandwiched between two layers of square-woven glass cloth, which serve to hold the skin assembly together, easing handling problems in the cured sheet form and providing a slightly more rugged surface in operation. Each of these surface layers is .004 inch thick, giving the skin a nominal total thickness of .023 inch. Weight for weight, this is approximately equal to .016-inch-thick aluminum alloy.

The secondary choice of skin material is a filament-wound wet layup using a recently developed advanced organic fiber with the trade name PRD-49. This fiber has excellent tensile characteristics, both modulus and strength, and demonstrates excellent abrasion resistance. A serious drawback, which originally prevented widespread acceptance of this fiber, is a negative coefficient of expansion. When the fibers are used as one element of a composite material using a heat-curing resin

system, this characteristic results in locked-in internal stresses (compression in the fibers, tension in the resin) after cooling. This problem is compounded by the poor compressive strength of PRD-49. The locked-in stresses and associated strain energy mean very poor impact resistance although the fibers themselves are extremely resilient and tough. Recently-developed resin systems combined with filament winding which pre-tensions the fibers have largely eliminated the problem of locked-in stresses. The cost of these new processes and materials is not well defined, but it is expected to approximate an increase of \$500 in price per skin set in quantity production.

For the aft core, a honeycomb formed of polyamide paper sheet ("Nomex" is a trade name for the material) was chosen rather than the next most practical alternate, aluminum honeycomb. Although slightly higher in price, the polyamide honeycomb has a number of advantages. Technically, because it is less flimsy, it can be handled at lower densities than aluminum, facilitating blade balance; in manufacture, it conforms to contour more readily without cell walls buckling, and it has a lower scrap rate because of its ease of handling; and in operation, it will not corrode, is less severely damaged by lightning strikes, is more resilient and therefore more dent-resistant, and is expected to be more easily repaired. The core material chosen for all the concepts is hexagonal honeycomb of polyamide paper, with 1/8 inch cell size and 1.8 lb/cu ft density.

The material of the trailing-edge spline is chosen for thermal contraction compatibility with the material of the spar. On cool-down after bonding, if the spline contracts by an amount significantly different from that of the spar, built-in strains will result, and the blade will probably be warped. This effect can be avoided by straining the components during the bond cure cycle, which adds cost and complexity to the bonding fixture and increases the labor required, or by minimizing the differential contraction. The latter approach is obviously preferable. Consequently, for those concepts having aluminum spars, aluminum trailing-edge splines are also selected. The same considerations apply to the spline as to the spar, so that 6061-T651 is again chosen.

The high density of stainless steel complicates the choice of spline material for those blades having stainless-steel spars. To provide favorable section balance, the spline would have to be so small in section that too little surface area would be available for bonding to the skins. The chosen alternative is to use unidirectional glass-fiber-reinforced plastic, which

has a coefficient of thermal expansion close to that of stainless steel, and only one quarter of the density. To minimize section balance problems without compromise to inplane stiffness and strength requirements, S-glass is chosen in spite of its higher cost than E-glass. To provide a chordwise tie for the spanwise filaments which are otherwise held together by resin only, a single ply of square-woven cloth is buried on the chord plane. This layer is extended aft beyond the trailing-edge trim line, providing a tab to hold the spline against slipping forward under bonding pressure. The skins can be brought back to the trailing edge, so the spline is a simple triangular shape rather than a keystone.

The choice of materials for the root reinforcement is based on those used in the current UH-1H blade, since the root area is virtually unrepairable in the field, except for simple blending operations; therefore, repairability is not a criterion. Technically, the root reinforcement has to perform the same function, independent of the design of the basic blade section, so there is no reason to select different materials. For compatibility with the stainless-steel spar, stainless-steel doublers were selected, of .012 inch thickness for weight equivalent to the standard .032 inch aluminum. Because these relatively thin doublers will conform to the contour without previous forming, this material was also considered for two of the blades with aluminum spars, and prices were obtained for this combination (Concepts 9 and 10 in Table I).

#### CHOICE OF AIRFOIL SECTION

A significant part of the manufacturing cost of the blade concepts is in the machining of the aft core to the airfoil contour. A considerable portion of this cost can be saved by simplifying the airfoil section to provide flat surfaces over the aft section enclosing the core. The core then needs to be carved on one side only, and with straight cuts. The possibilities of such an airfoil are explored in Reference 3.

The simplified airfoil is based on an NACA 0015 airfoil with a 16.8-inch chord, extended by straight lines tangent to this surface to give a total chord of 21.0 inches. The trailing-edge thickness is made the same as that of the standard 21.0-inch NACA 0012 section, so the tangent points are 8.87 inches from the leading edge.

Technically, this simplified airfoil provides some advantages in chordwise balance, because the point of maximum thickness is moved closer to the leading edge. More volume is available in the leading edge than in that of the standard section, and the aft section is thinner.

Aerodynamically, the significant parametric change is in the leading-edge radius, which is increased over that of the standard section. The effects of this change are examined in the technical section of this report. The forward movement of the point of maximum thickness is not expected to have any significant effect on the center of pressure or on the lift curve slope.

In Table I, the odd-numbered concepts have the modified airfoil with straight-sided aft section, while the even-numbered concepts use the standard NACA 0012, 21.0-inch-chord airfoil. The differences between the airfoils are shown graphically in Figures 6 through 9.

#### CONCEPTS WITH EXTRUDED ALUMINUM SPARS

Eight of the blade concepts listed in Table I have extruded aluminum spars. These are Concepts 1, 2, 7, 8, 9, 10, 11, and 12. Because they differ from one another only in detail, Figure 3 is representative of all eight, except that the removable and replaceable polyurethane leading-edge abrasion sheath of Concepts 7 and 8 is not shown.

It can be seen that the standard airfoil costs \$73 more than the simplified airfoil, in mid-1971 costs. The leading-edge abrasion sheath adds \$25 per blade. In spite of the elimination of pre-forming, the stainless-steel doublers are more expensive than aluminum alloy, partly because the material itself is slightly more expensive, but primarily because of an increase in machining cost in cutting the planform. For Designs 11 and 12, which have filament-wound PRD-49 composite skins, \$500 per blade has been added to the cost.

#### CONCEPTS WITH FORMED SHEET STAINLESS-STEEL SPARS

Concepts 3 through 6 have spars assembled from formed stainless-steel sheet. Concepts 3 and 4 use stretch pressing to form the shapes of the spar members, and in Concepts 5 and 6, these components are rolled. Figure 4 shows the general arrangement of Concepts 3 and 4 and Figure 5 that of Concepts 5 and 6. The sections are shown in Figures 6 through 9.

In Concepts 3 and 4, advantage is taken of the capability of stretching to allow a variation in shape along the part. To assist the desired forward movement of the center of gravity with increasing radius, the vertical web of the forward channel is allowed to move forward. At the same time, a technically desirable flapwise stiffness taper is obtained

as the width of the nose skin is machined down and the flanges of the forward channel become narrower. With the flanges projecting forward, the web of the forward channel provides a stiffener for the relatively flat and thin unsupported panel on the bottom of the spar, which is loaded in compression in static bending.

In Concepts 5 and 6, the forward channel is reversed, placing the web on a constant chordwise station to allow rolling. The reversal was necessary for balance, since the web would have been too far aft outboard. To stiffen the undersurface of the spar, the lower aft edge of the channel is turned upward over approximately half its length, in a separate forming operation. Flapwise stiffness taper is still provided by the machining cuts on the edges of the nose skin and forward channel.

The spars of Concepts 3 and 5, with the modified airfoil, extend aft to the tangent point, so the core has four flat sides. This point does not exist in Concepts 4 and 6, so the spars are of more convenient width.

The roll-formed spars are significantly less expensive than stretch-forming, but they are still not competitive with extruded aluminum. Sheet-metal spars are desirable, in combination with stretch-forming, only when the additional cost is justified by technical considerations which require a spanwise variation in airfoil section.

## TECHNICAL ANALYSIS

In the preliminary design phase, the technical characteristics and design features of the current UH-1H main rotor blade were used as the basis for the design of the field repairable/ expendable blade concepts. The weight and balance characteristics and section properties were matched as closely as possible to those of the current blade. The design specification, of course, was written with this objective. Aerodynamically, the only change is the alternate airfoil section described above.

By designing each blade to have section properties as close as possible to those of the current blade, the predicted dynamic characteristics, natural frequencies and flight bending moments, were quite similar, and structural margins of safety and fatigue lives differ very little, primarily due to material changes.

### CURRENT UH-1H MAIN ROTOR BLADE CHARACTERISTICS

The contractor's standard computer programs were used to determine the characteristics of the current blade so that this and the field repairable/expendable concepts would be compared on the same bases.

Table II gives the computer-derived weight and balance characteristics. Actual used UH-1D/H main rotor blades were weighed on the contractor's balance fixture to confirm these values. Since the computer program integrates section properties to obtain weight and balance data, the physical weighing also served as partial confirmation of the section property computations.

The section properties computed for the current blade are plotted in Figures 10 through 15, and the natural frequencies and computed flight bending moments are presented in Figures 16 through 18.

### SECTION PROPERTIES

The section properties of the basic concepts were computed and plotted. Concepts 1 through 6 are significantly different from one another, but Concepts 7 through 12 are detail variations from Concepts 1 and 2, and can be considered technically identical—Concepts 7, 9, and 11 with Concept 1, and Concepts 8, 10, and 12 with Concept 2.

The section property plots for Concept 2 are presented in

**TABLE II. WEIGHT AND BALANCE,  
CURRENT UH-1H BLADE**

CURRENT UH-1H BLADE  
(NOMINALLY BALANCED, AS WEIGHED, WITH TRIM TAB AND PAINT)

**BLADE WEIGHT AND BALANCE:**

TOTAL BLADE WEIGHT	= 203.495	POUNDS
MOMENT ABOUT CENTER OF ROTATION	= 28959.5	LB-IN.
SPANWISE CENTER OF GRAVITY	= 142.31	IN. FROM C. ROT.
CHORDWISE CENTER OF GRAVITY	= 5.74233	IN. FROM L. E.
DYNAMIC MASS AXIS	= 5.03968	IN. FROM L. E.

(I.E. SPAN-WEIGHTED CHORDWISE CENTER OF GRAVITY)  
INERTIA ABOUT CENTER OF ROTATION = 1228.84

**CENTRIFUGAL LOADING AT ONE (1.0) RADIAN/SECOND:**

SPAN STATION (RADIUS) (INCHES)	CENTRIFUGAL FORCE (POUNDS)	IN-PLANE BENDING MOMENT ABOUT N. A. (LB-IN., + FOR L. E. IN TENSION)
24.50	74.95	15.76
25.00	74.81	266.51
31.80	73.33	119.11
45.90	71.70	87.46
60.00	69.65	50.75
70.50	68.06	71.58
81.00	66.50	65.06
95.50	64.33	65.88
110.00	61.80	21.23
125.60	59.31	14.86
141.20	56.49	16.83
156.80	53.34	19.03
172.40	49.86	21.45
188.00	46.04	-16.09
210.00	38.95	-14.90
227.00	33.07	-13.57
244.00	26.73	16.73
256.57	21.47	-6.78
272.50	14.77	-5.51
282.50	9.18	-4.42
288.00	0.00	0.00

**STATIC BENDING (DROOP) AT 1.0G:**

SPAN STATION (INCHES)	BENDING MOM. (LB-IN.)	DEFLECTION (INCHES)
24.50	2397.18	0.00
25.00	23877.98	0.00
31.80	22577.30	0.00
45.90	20136.67	0.03
60.00	17916.32	0.10
70.50	16391.06	0.18
81.00	14957.15	0.29
95.50	13103.76	0.52
110.00	11388.09	0.81
125.60	9680.11	1.21
141.20	8099.65	1.68
156.80	6646.71	2.22
172.40	5321.28	2.28
188.00	4123.38	3.46
210.00	2675.45	4.41
227.00	1762.09	5.18
244.00	1025.59	5.96
256.57	597.44	6.55
272.50	197.43	7.30
282.50	34.18	7.77
288.00	0.00	8.03

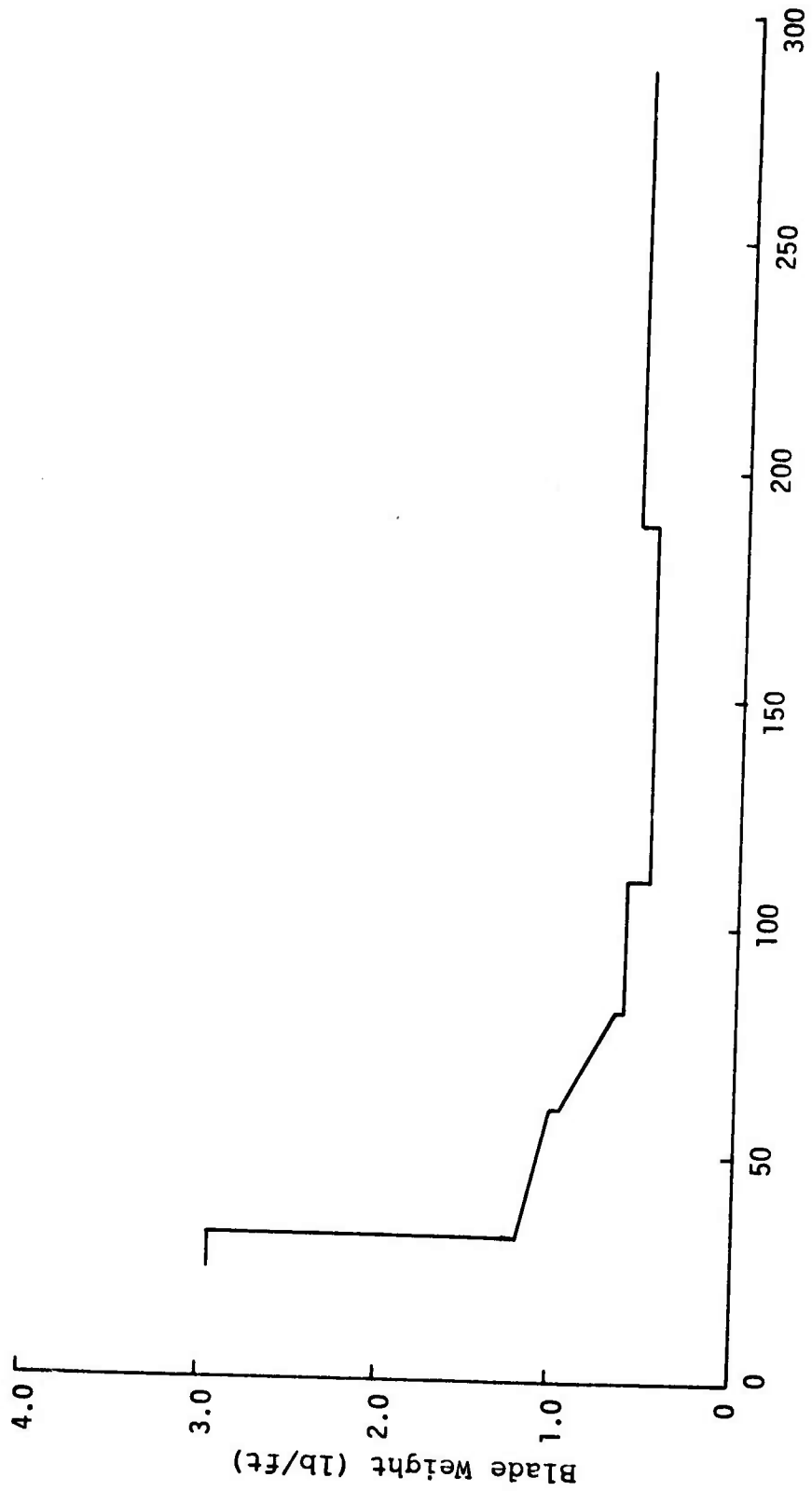

Blade Station (in.)

Figure 10. Weight Distribution, Current UH-1H Blade.

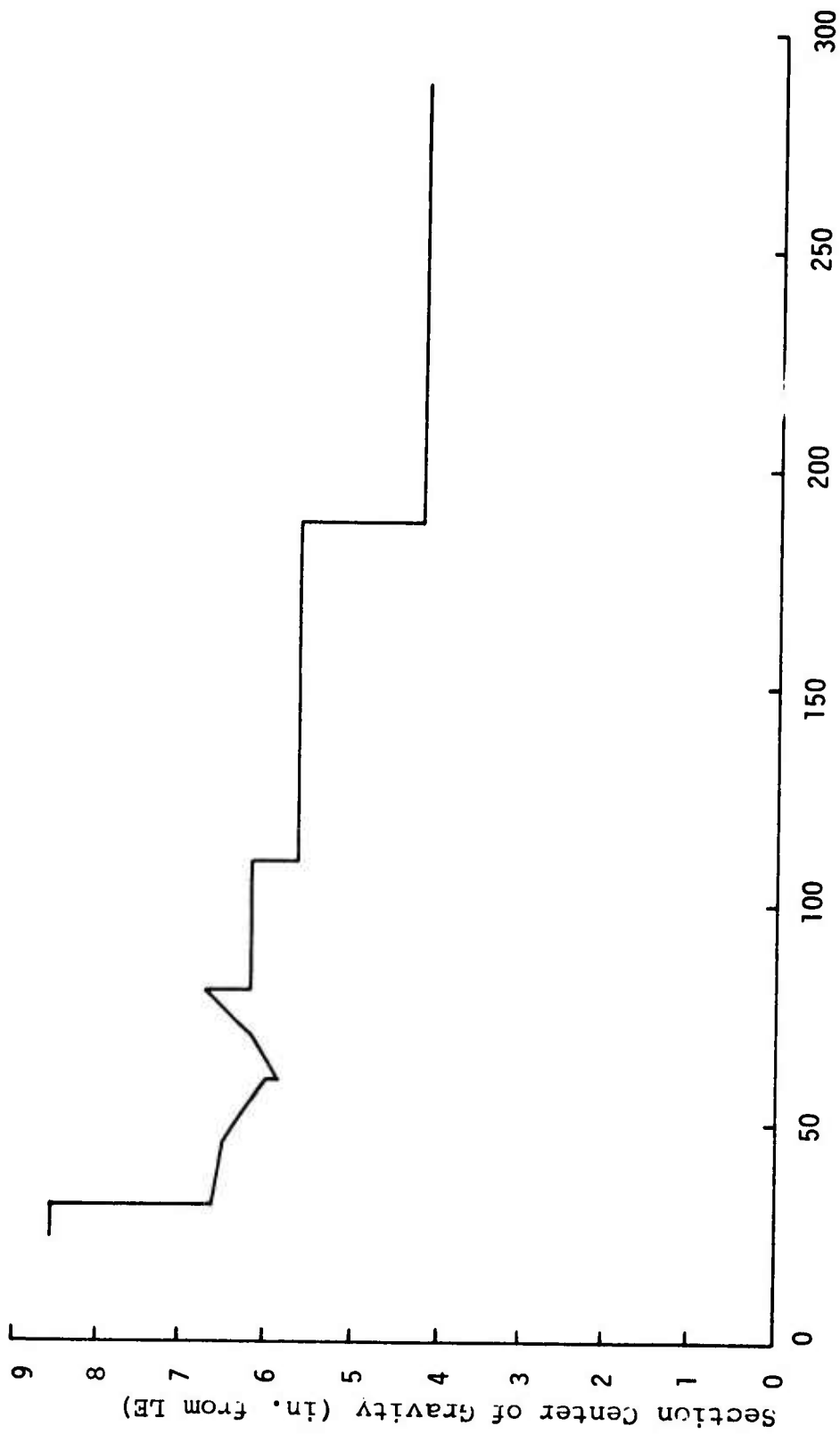

Blade Station (in.)

Figure 11. Center of Gravity Location, Current UH-1H Blade.

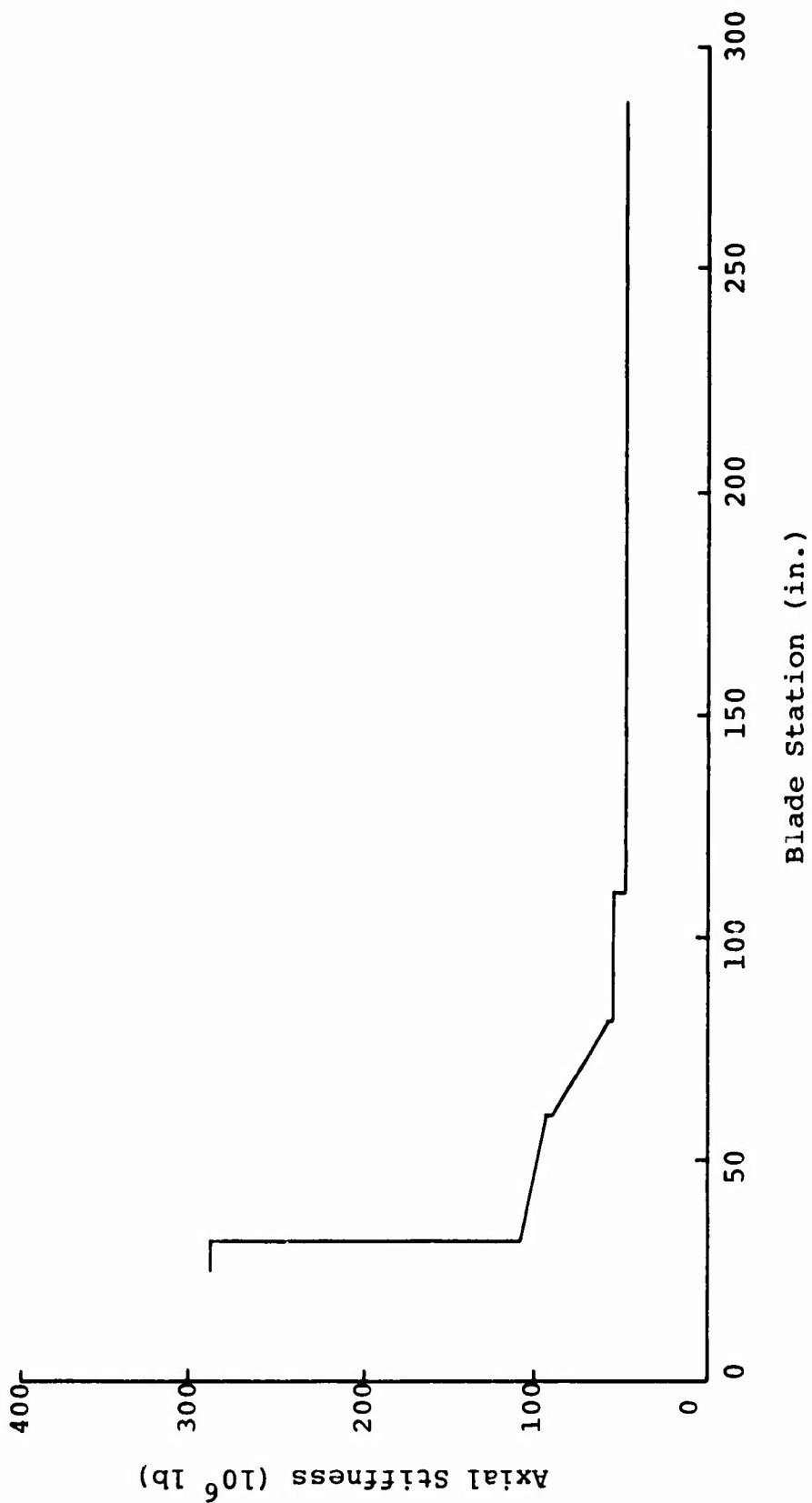

Figure 12. Axial Stiffness Distribution, Current UH-1H Blade.

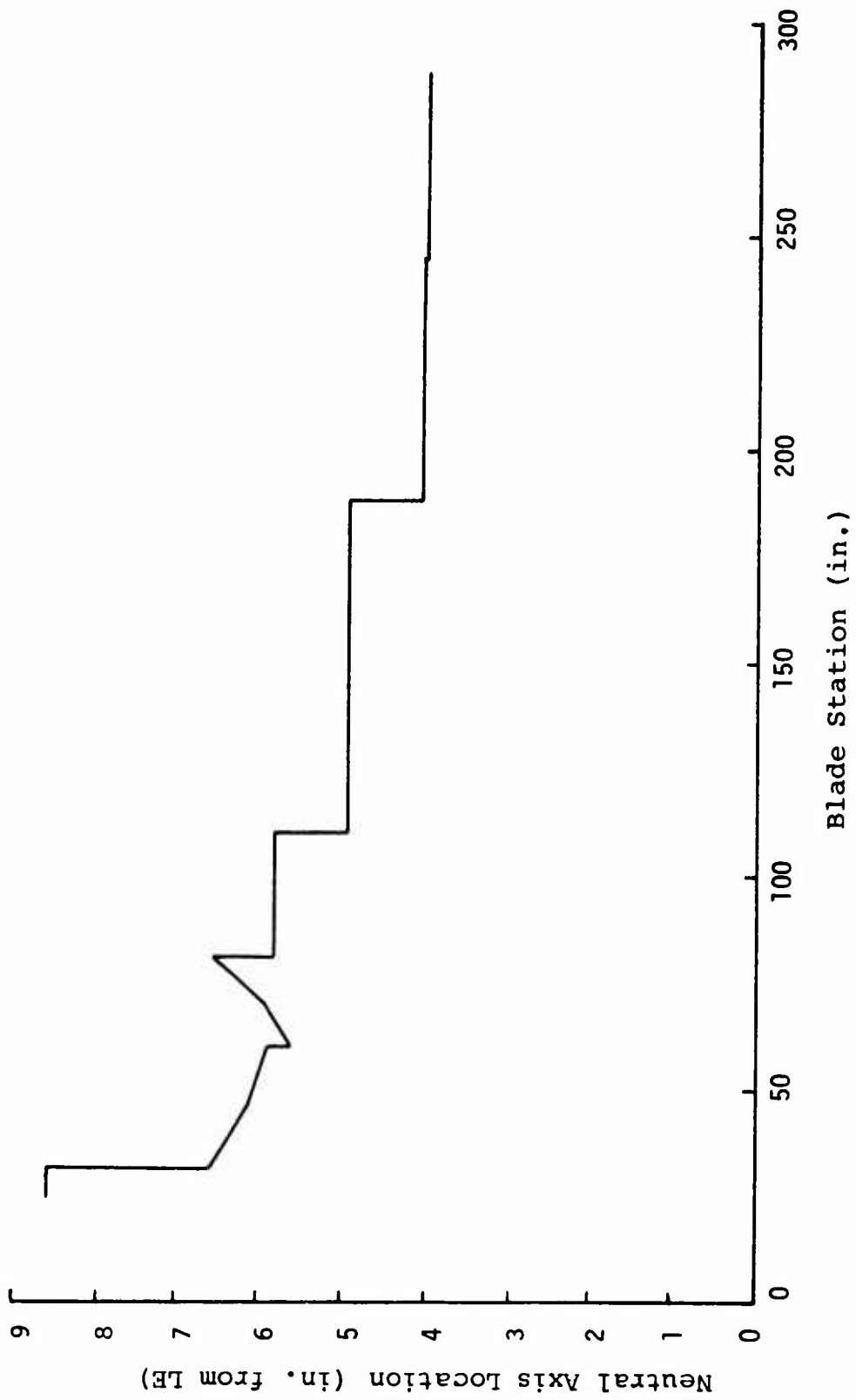

Figure 13. Neutral Axis Location, Current UH-1H Blade.

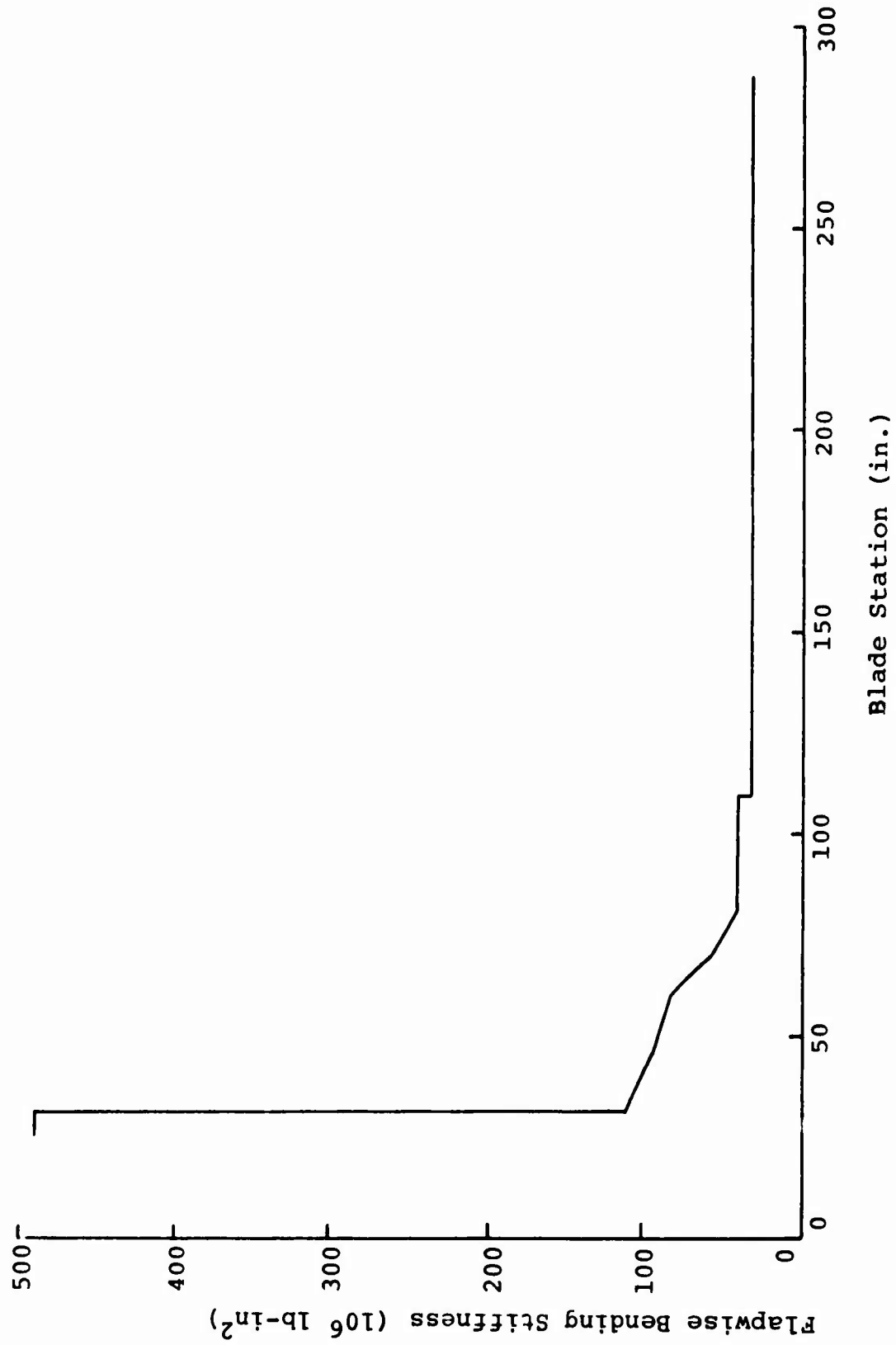

Figure 14. Flapwise Bending Stiffness Distribution, Current UH-1H Blade.

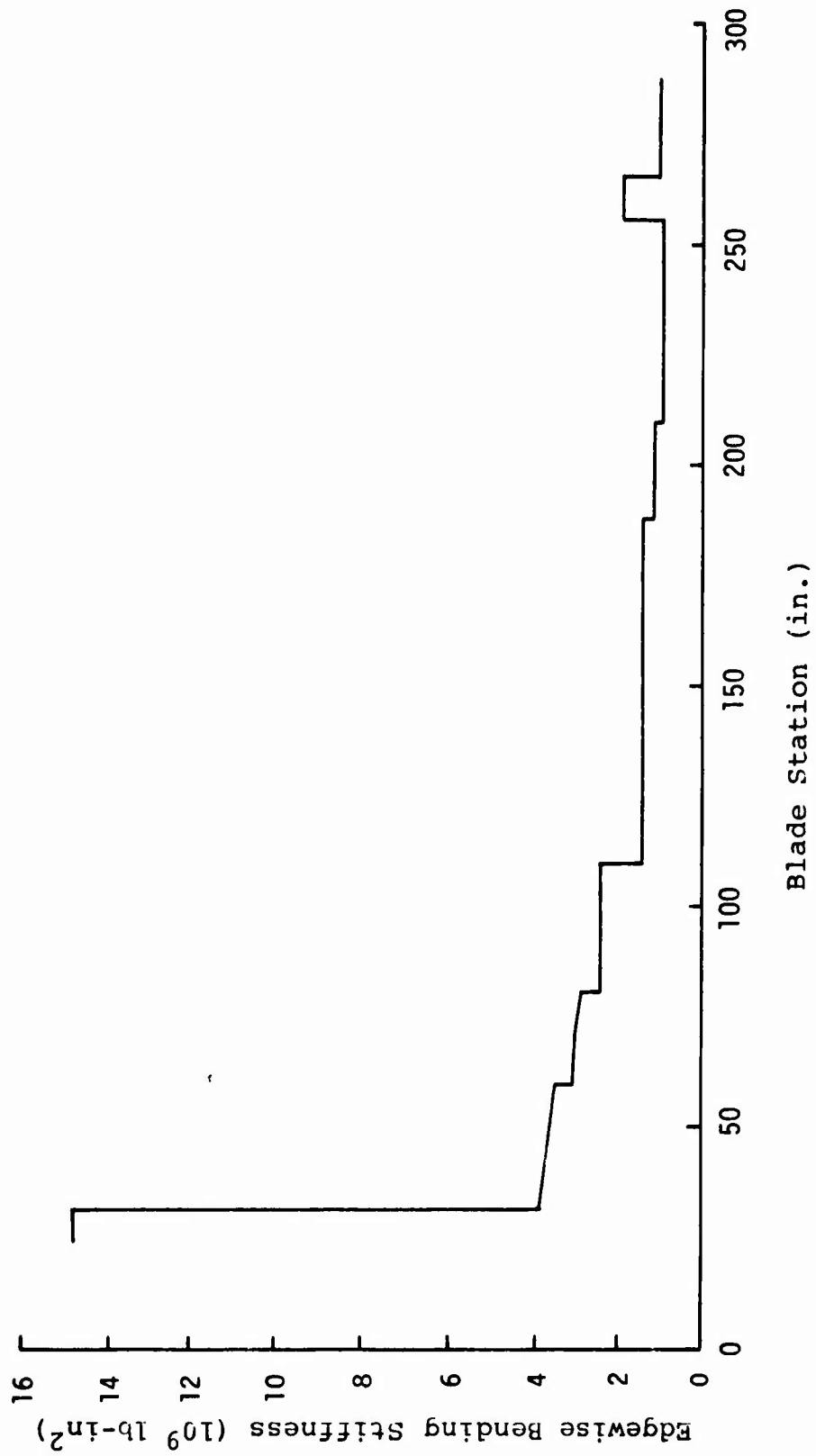

Figure 15. In-Plane Bending Stiffness Distribution, Current UH-1H Blade

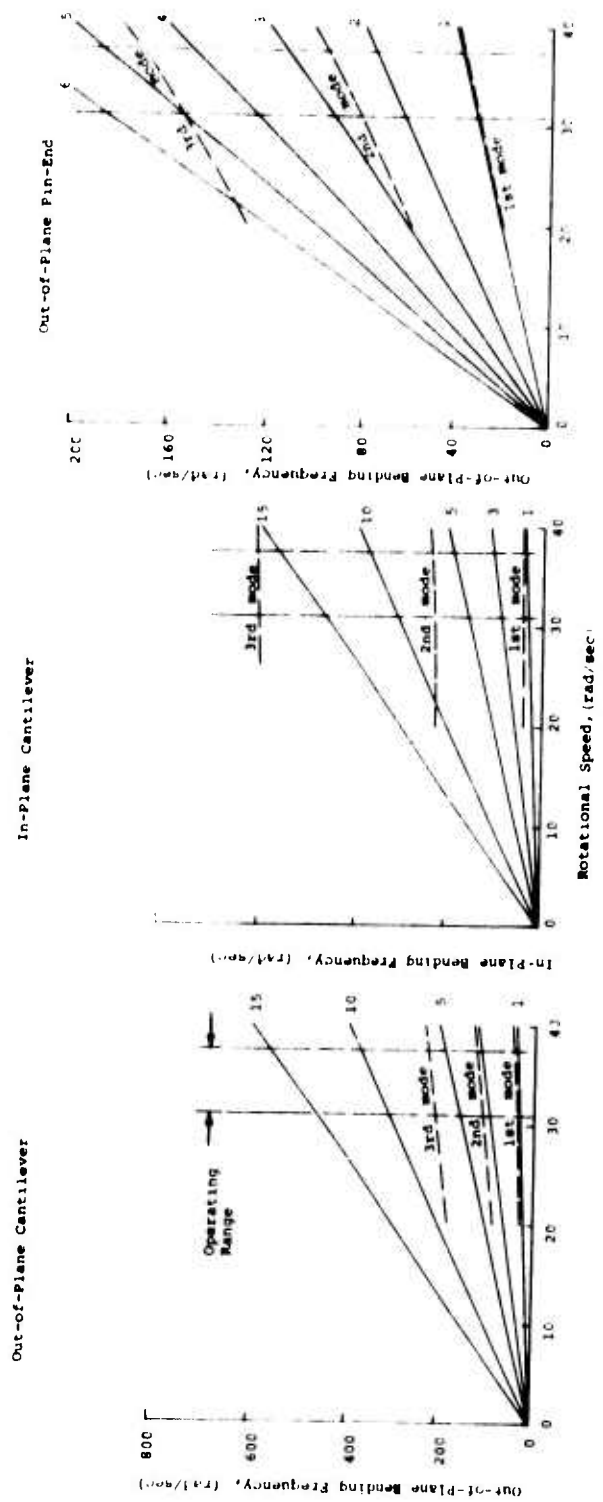

Figure 16. Natural Frequencies, Current UH-1H Blade.

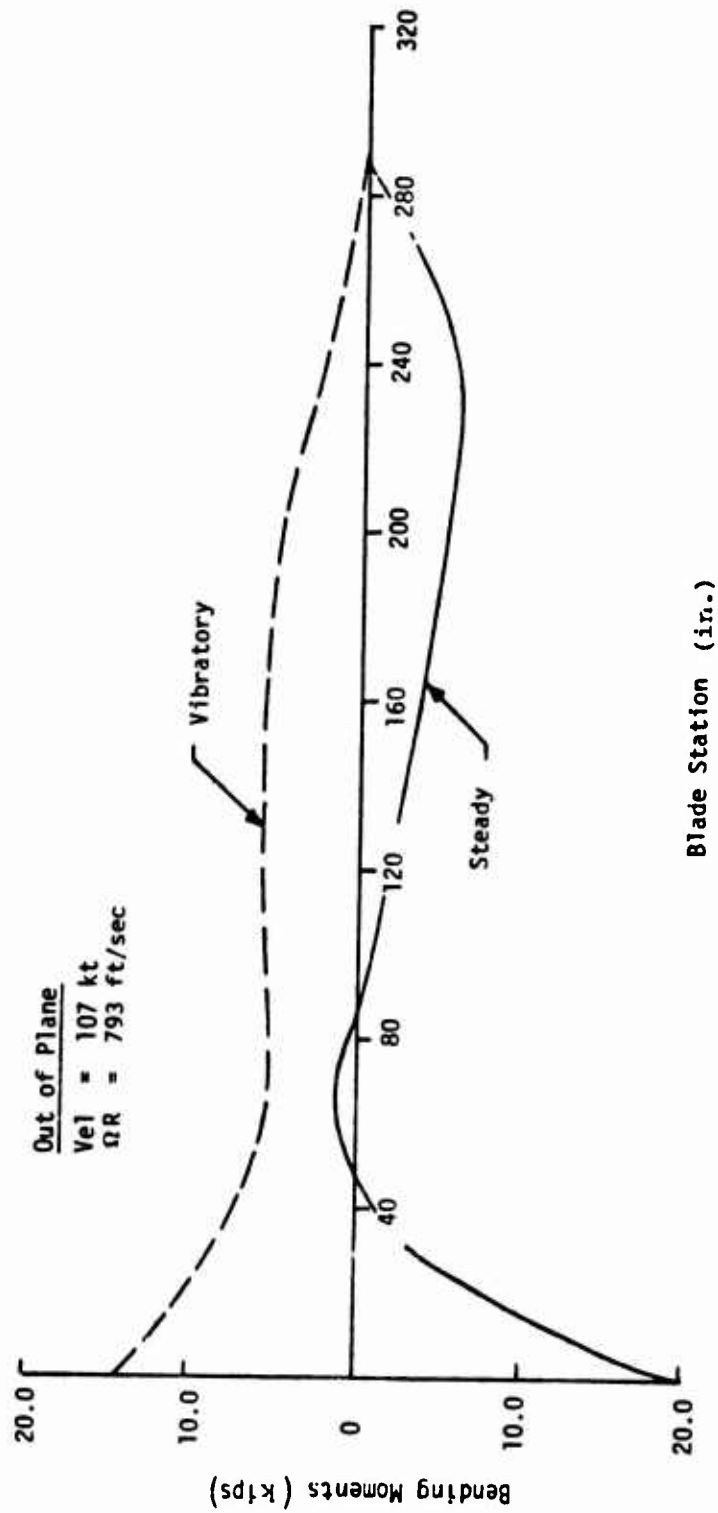

Figure 17. Dynamic Flapwise Bending Moments, Current UH-1H Blade.

Figures 19 through 24, and are typical of those obtained for all the concepts.

#### WEIGHT AND BALANCE

The computer output for Concept 2 is shown in Table III, and Table IV summarizes the weight and balance characteristics for Concepts 1 through 6.

In the preliminary design stage, it was considered sufficient to show that the basic blade design provided the opportunity to meet the specified weight and balance requirements, but design of the actual tip weights required to achieve this goal was deferred to the detail design phase.

#### CENTRIFUGAL AND STATIC LOADS AND MOMENTS

Figures 25 and 26 present, respectively, the computer derived centrifugal loading at 309 rpm and the static (1.0g) bending. The centrifugal force distribution, the induced in-plane bending moments due to the offset of the c.f. vectors from the section neutral axes, the static bending moment distribution, and the static deflection are presented for Concept 2. These plots are typical of those determined for all concepts.

#### NATURAL FREQUENCIES

The natural frequency plots obtained for Concept 2 are presented in Figure 27. The small difference between these curves and those plotted for the current blade is typical of all the design concepts.

#### DYNAMIC BENDING MOMENTS

The computed dynamic flight bending moments obtained for Concept 2 are presented in Figures 28 and 29. The dynamic stress analysis of Concept 2 was based on these bending moments, and the curves are typical of those used in the stress analyses of all concepts.

#### STRESS ANALYSIS

A stress analysis based on the computed dynamic bending moments and the centrifugal loading applied to the section properties was performed for each of the design concepts at several spanwise stations.

For every concept, Station 81.0, immediately outboard of the root reinforcing doublers, proved to be the critical section. Table V presents the summarized stress analyses at this

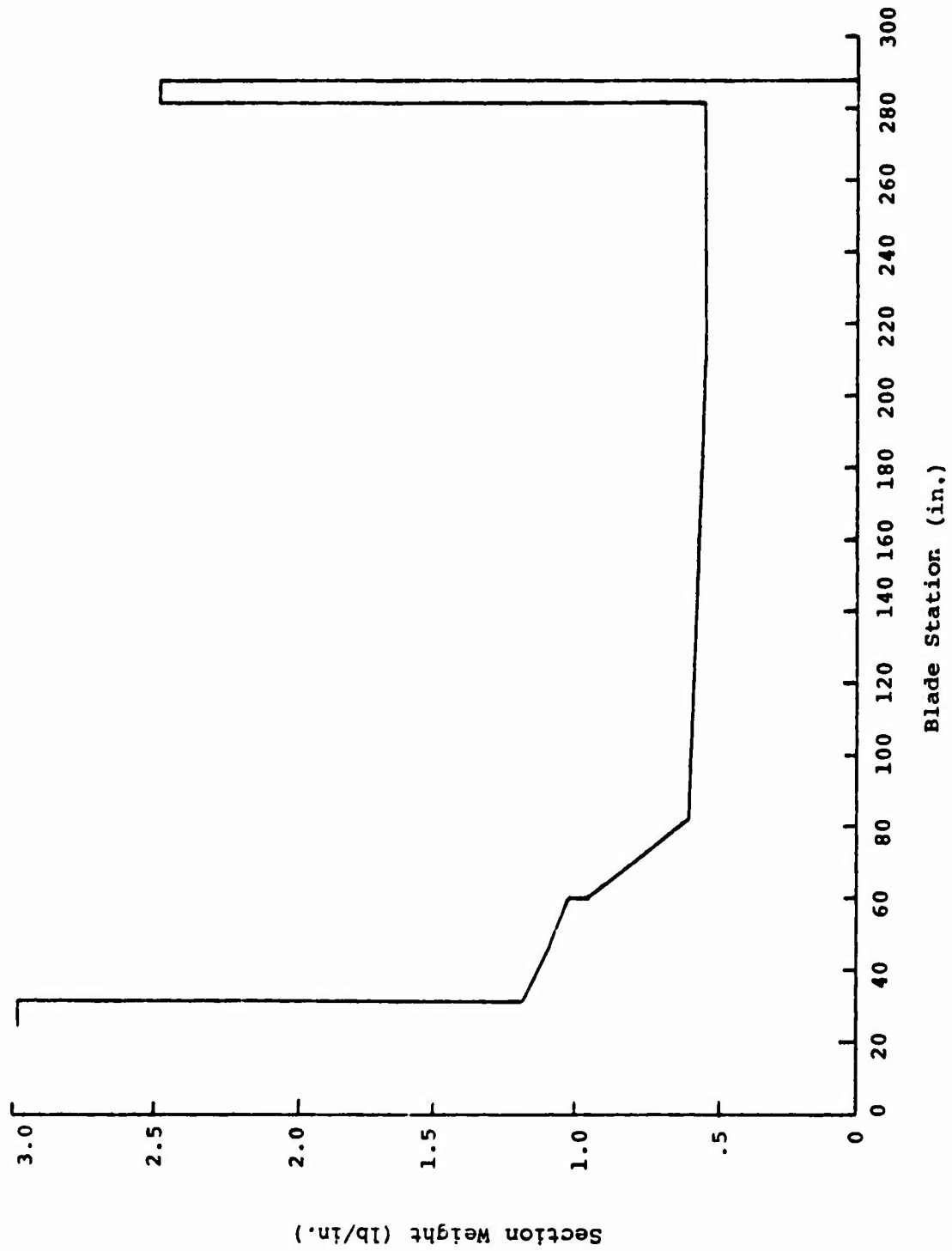

Figure 19. Weight Distribution, Concept 2.

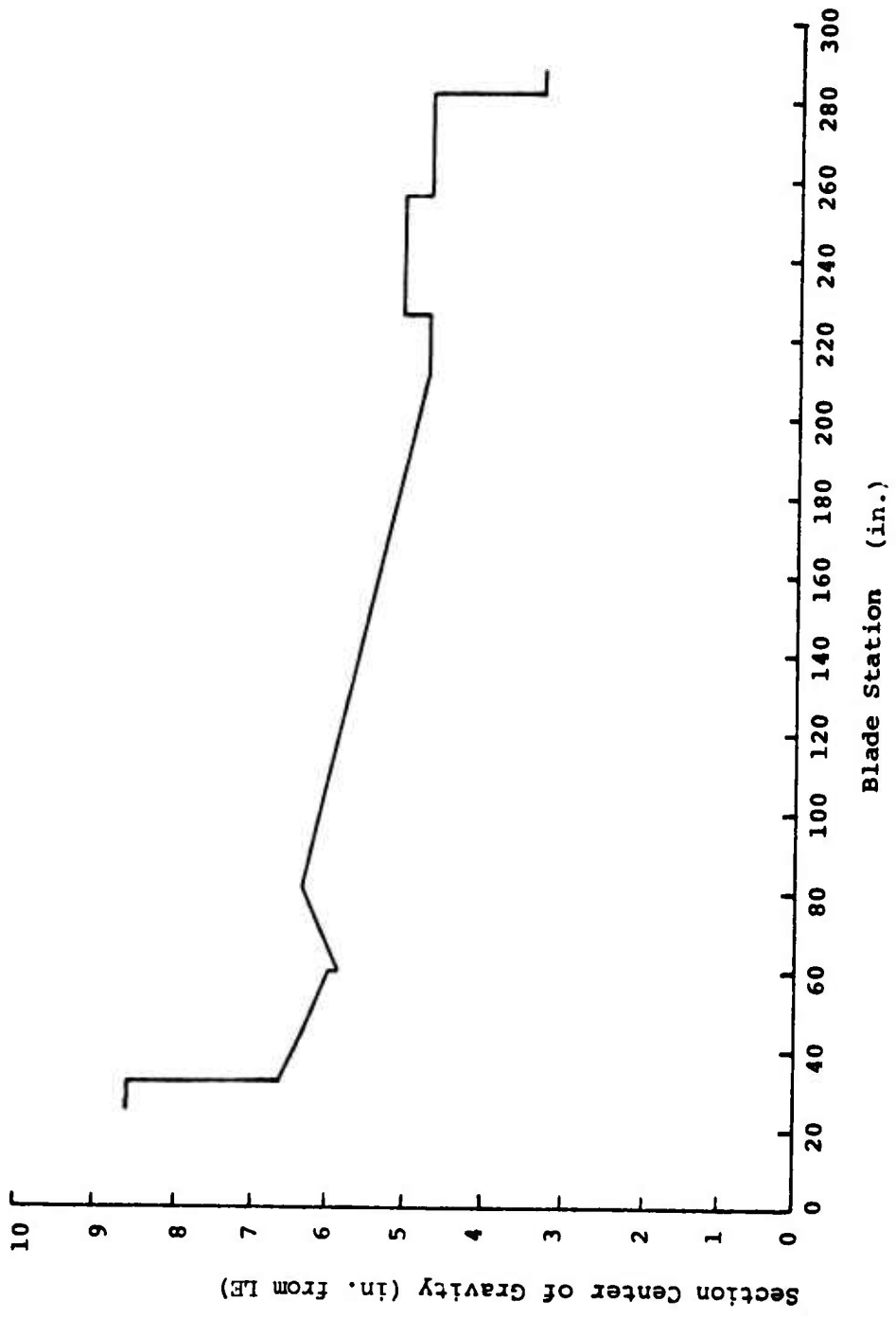

Figure 20. Center of Gravity Location, Concept 2.

Preceding page blank

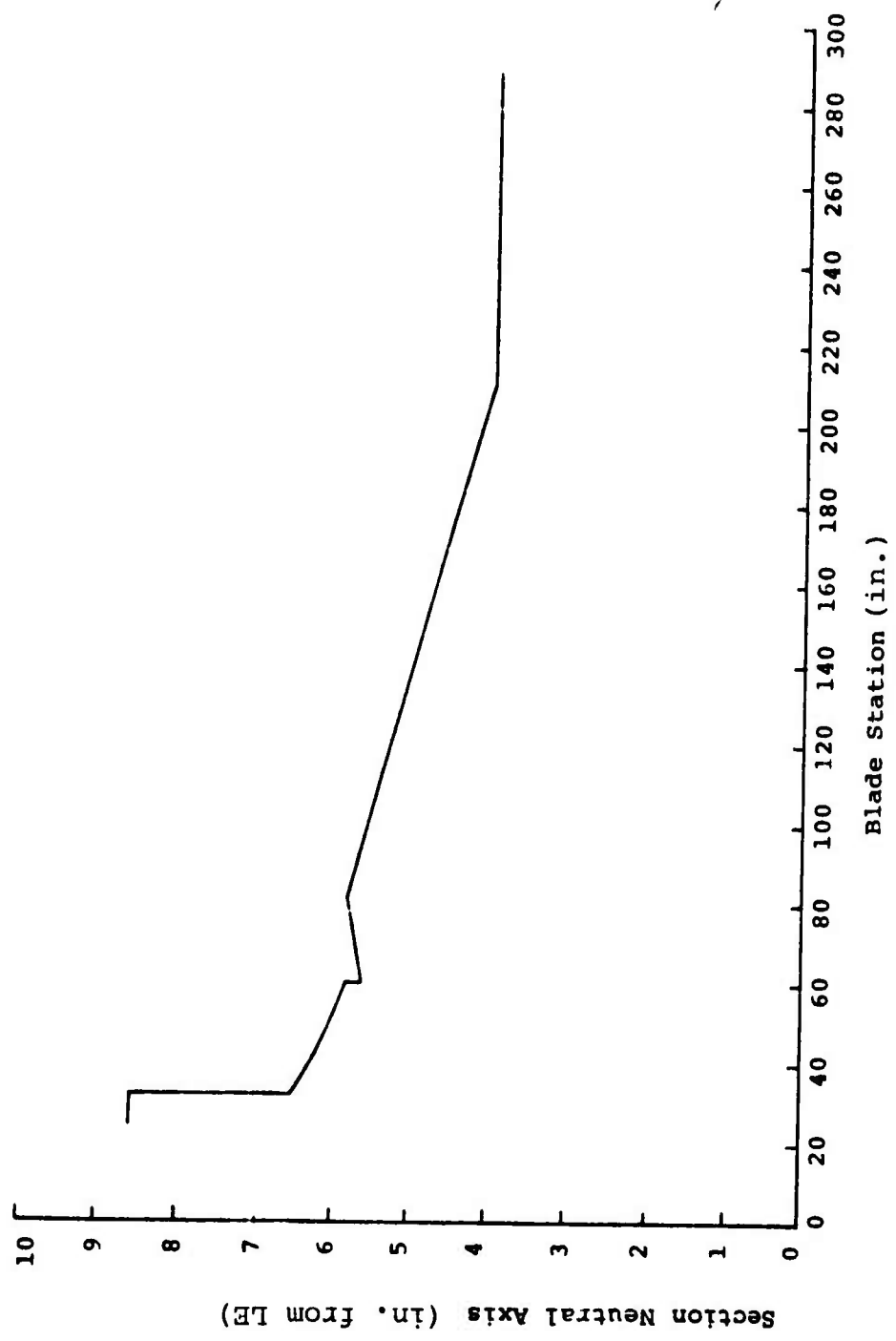

Figure 22. Neutral Axis Location, Concept 2.

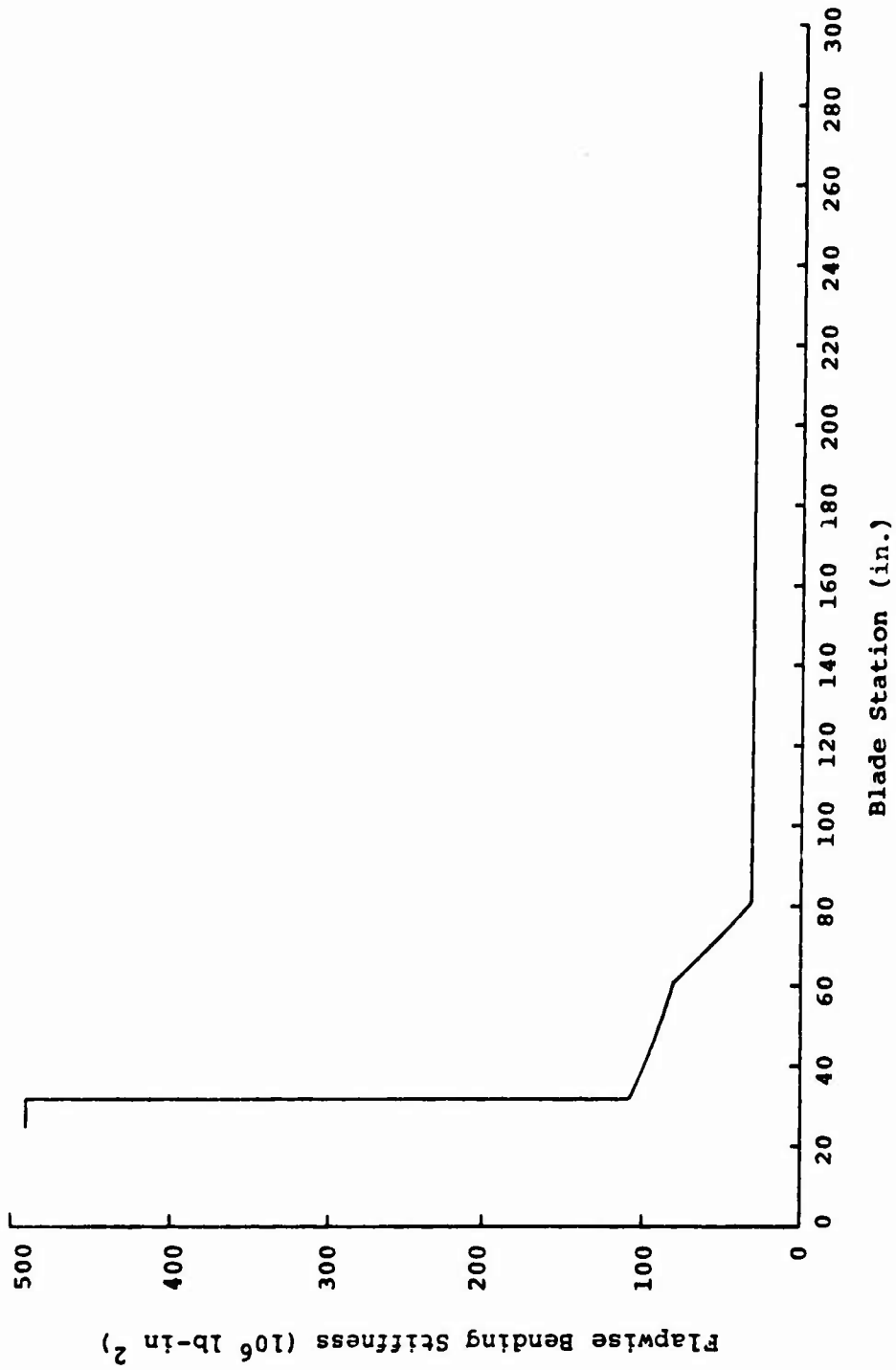

Figure 23. Flapwise Bending Stiffness Distribution, Concept 2.

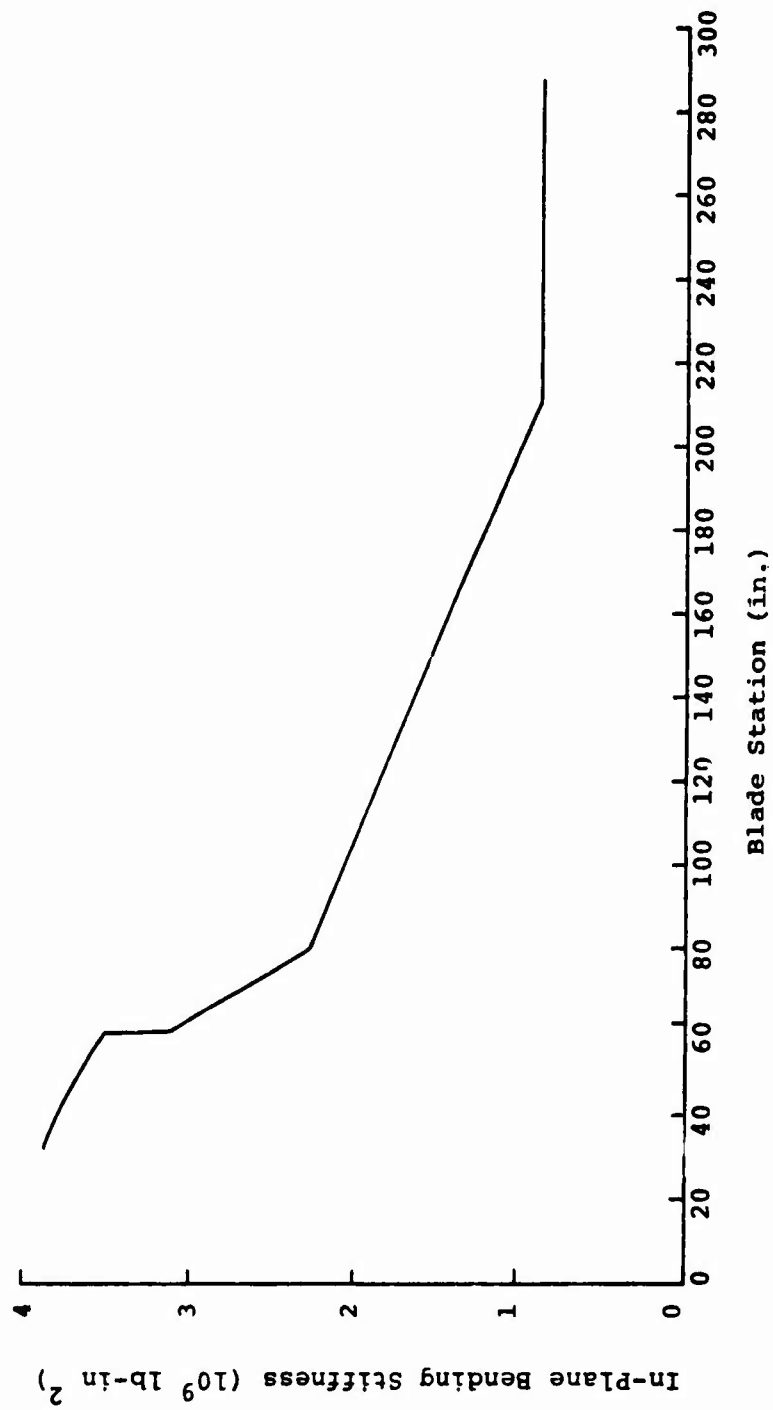

Figure 24. In-Plane Bending Stiffness Distribution, Concept 2.

TABLE III. WEIGHT AND BALANCE,  
CONCEPT 2

FREB DESIGN CONCEPT 2

BLADE WEIGHT AND BALANCE:

TOTAL BLADE WEIGHT	= 198.989	POUNDS
MOMENT ABOUT CENTER OF ROTATION	= 28041.9	LB-IN.
SPANWISE CENTER OF GRAVITY	= 140.972	IN. FROM C. ROT.
CHORDWISE CENTER OF GRAVITY	= 5.74741	IN. FROM L. E.
DYNAMIC MASS AXIS (I.E. SPAN-WEIGHTED CHORDWISE CENTER OF GRAVITY)	= 5.07104	IN. FROM L. E.
INERTIA ABOUT CENTER OF ROTATION	= 1179.21	SLUGS-FT. SQ.

CENTRIFUGAL LOADING AT ONE (1.0) RADIAN/SECOND:

SPAN STATION (RADIUS) (INCHES)	CENTRIFUGAL FORCE (POUNDS)	IN-PLANE BENDING MOMENT ABOUT N. A. (LB-IN., + FOR L. E. IN TENSION)
24.50	72.57	255.45
31.80	71.00	112.74
45.90	69.38	82.10
60.00	67.34	46.61
81.00	64.34	60.29
97.12	62.07	47.11
113.25	59.42	34.77
129.37	56.42	23.38
145.50	53.06	13.04
161.62	49.37	3.83
177.75	45.34	-4.16
193.87	41.00	-10.84
210.00	36.36	-16.13
226.50	31.26	-0.18
241.25	26.27	3.48
256.00	20.96	-0.65
282.00	11.06	7.06
288.00	0.00	0.00

STATIC BENDING (DROOP) AT 1.0G:

SPAN STATION (INCHES)	BENDING MOM. (LB-IN.)	DEFLECTION (INCHES)
24.50	23184.08	0.00
31.80	21810.27	0.00
45.90	19422.87	0.03
60.00	17254.55	0.09
81.00	14356.48	0.29
97.12	12344.68	0.56
113.25	10490.58	0.92
129.37	8791.96	1.37
145.50	7246.63	1.89
161.62	5852.37	2.47
177.75	4606.96	3.09
193.87	3508.21	3.76
210.00	2553.89	4.45
226.50	1725.17	5.18
241.25	1111.72	5.84
256.00	619.89	6.51
282.00	45.00	7.71
288.00	0.00	7.98

TABLE IV. WEIGHT AND BALANCE SUMMARY

Concept	Total Blade Wt (lb)	Spanwise CG (in. from C. Rot.)	Chordwise CG (in. from LE)	Dynamic Mass Axis (in. from LE)
1	188.1	136.4	5.707	5.036
2	199.0	140.9	5.747	5.071
3	199.9	136.9	5.829	5.093
4	201.8	140.8	5.905	5.086
5	199.3	137.7	5.758	5.061
6	196.3	136.1	5.403	5.097
Current UH-1H	203.5	142.3	5.742	5.040

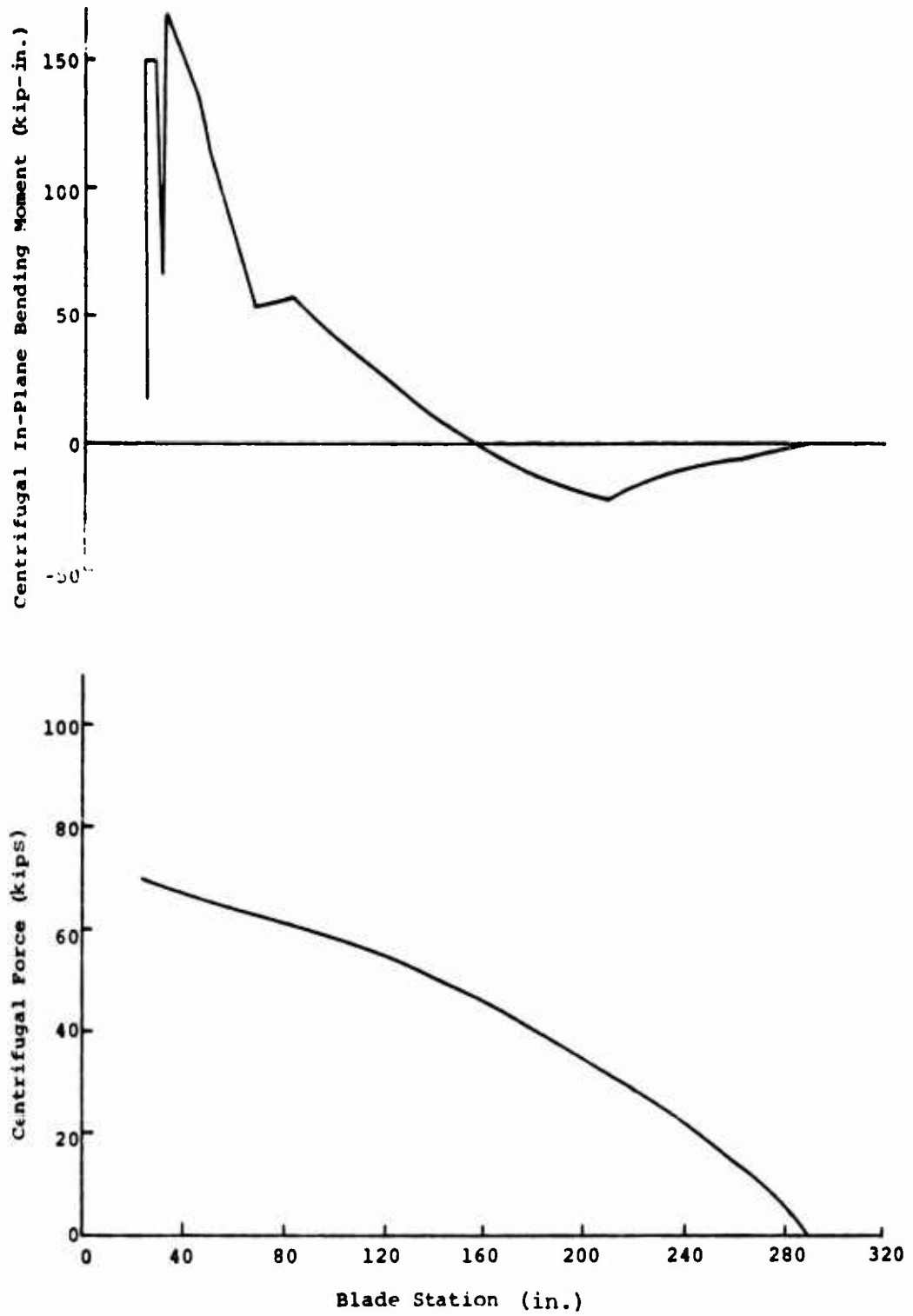

Figure 25. Centrifugal Loading Distributions, Concept 2.

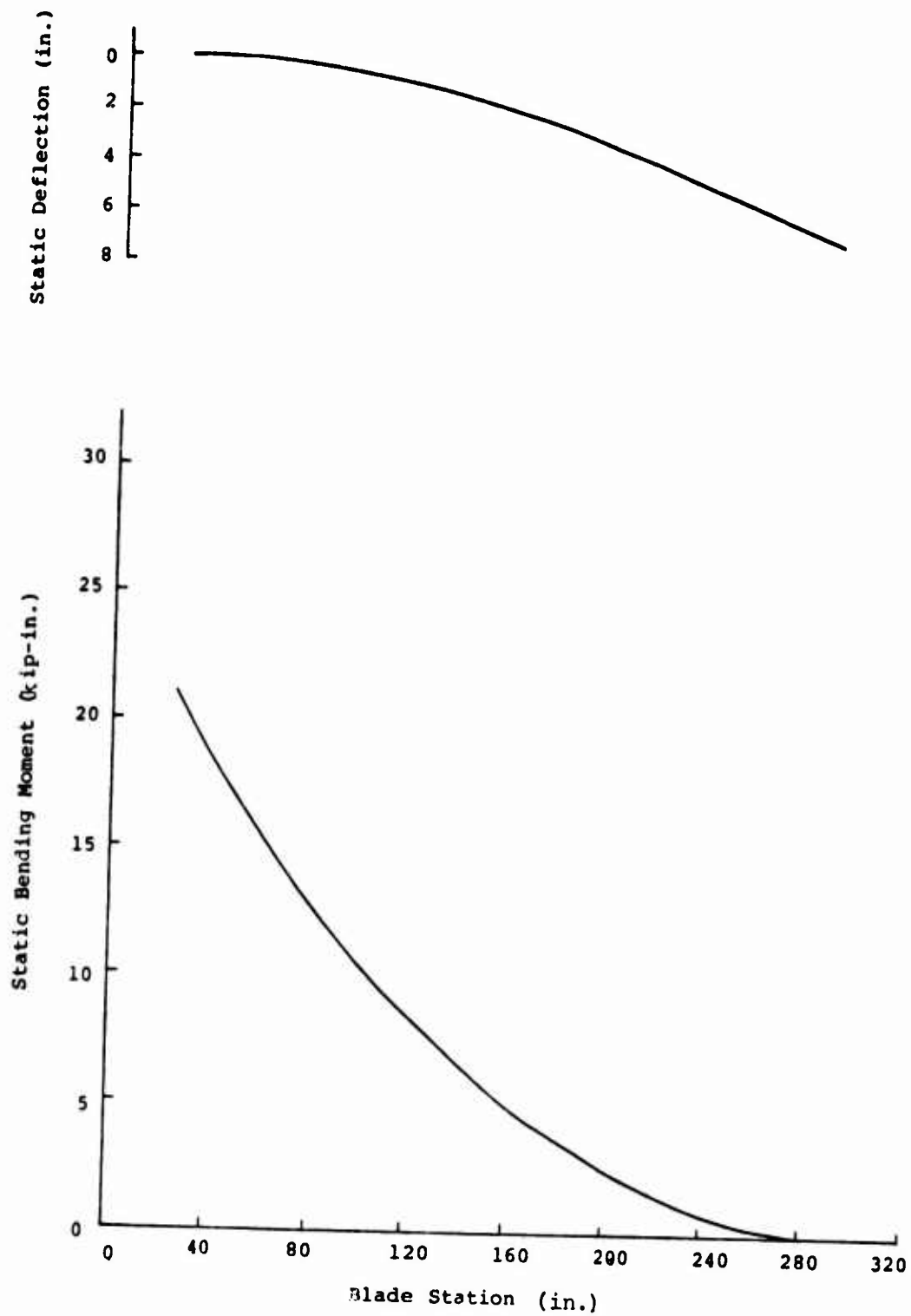

Figure 26. Static Bending, Concept 2.

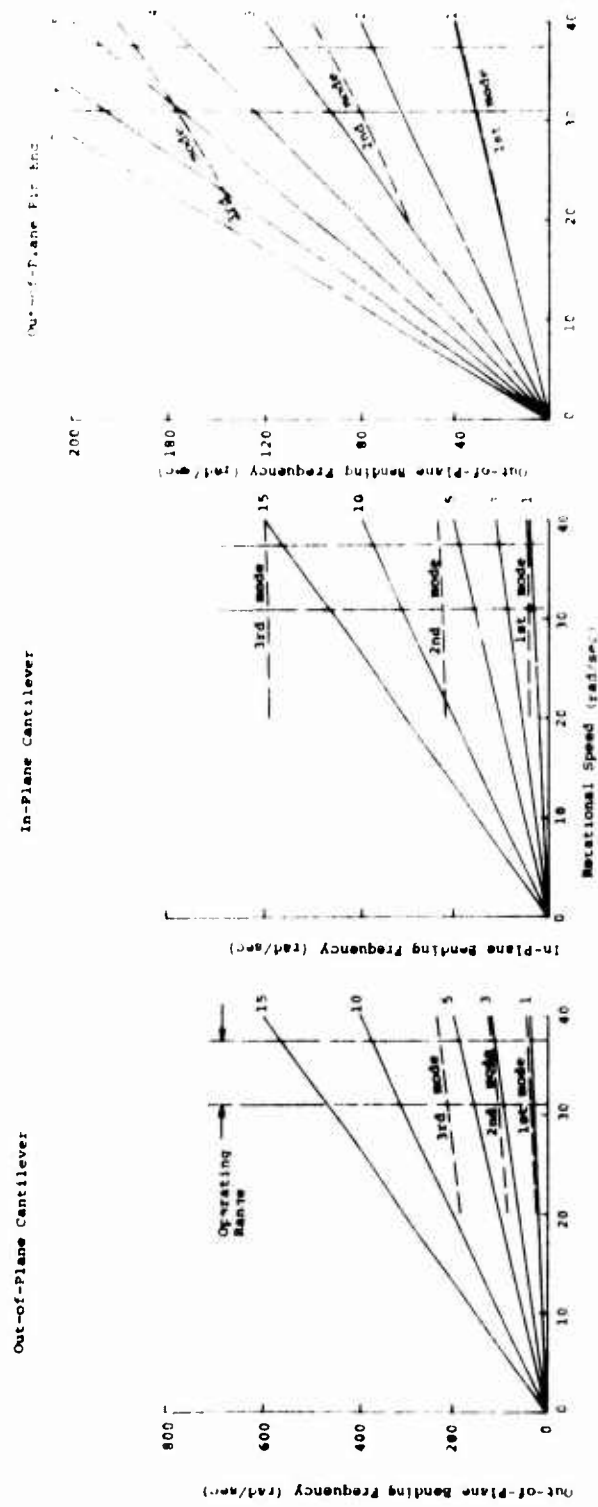

Figure 27. Natural Frequencies, Concept 2.

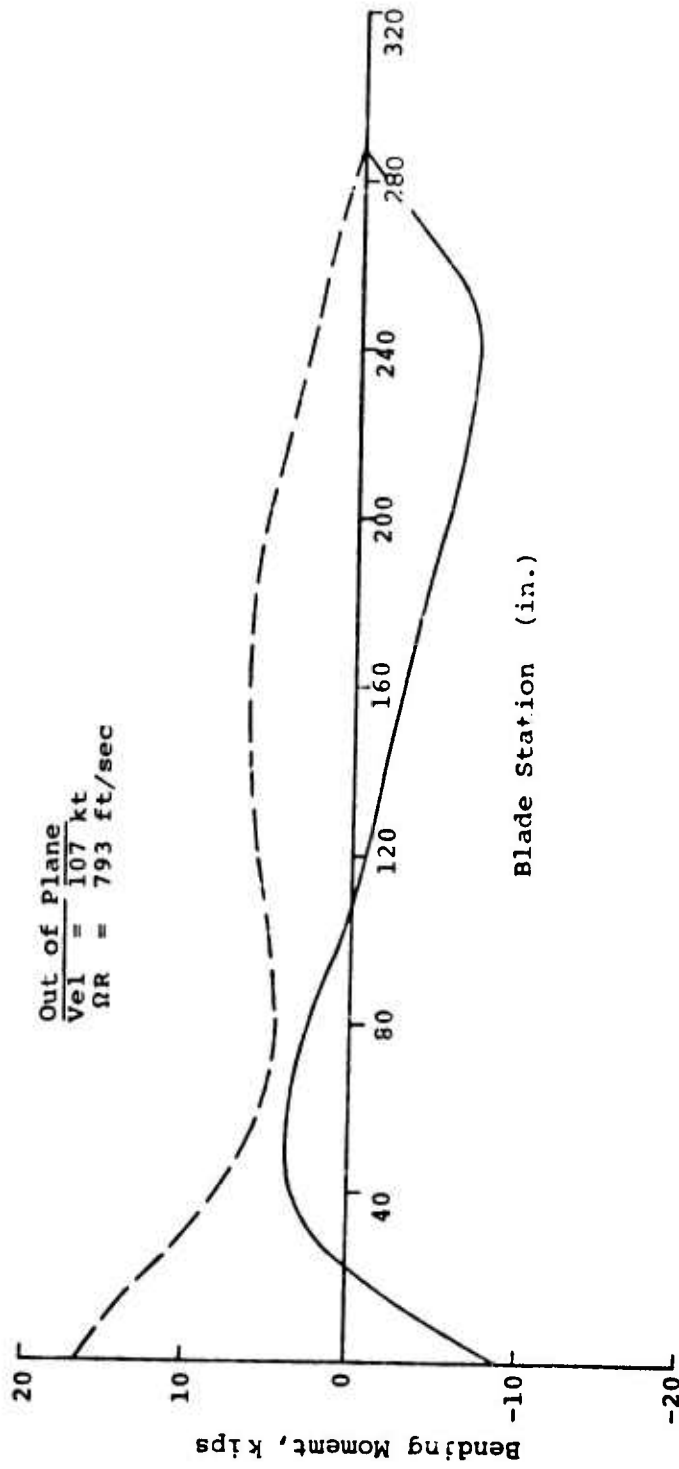

Figure 28. Dynamic Flapwise Bending Moments, Concept 2.

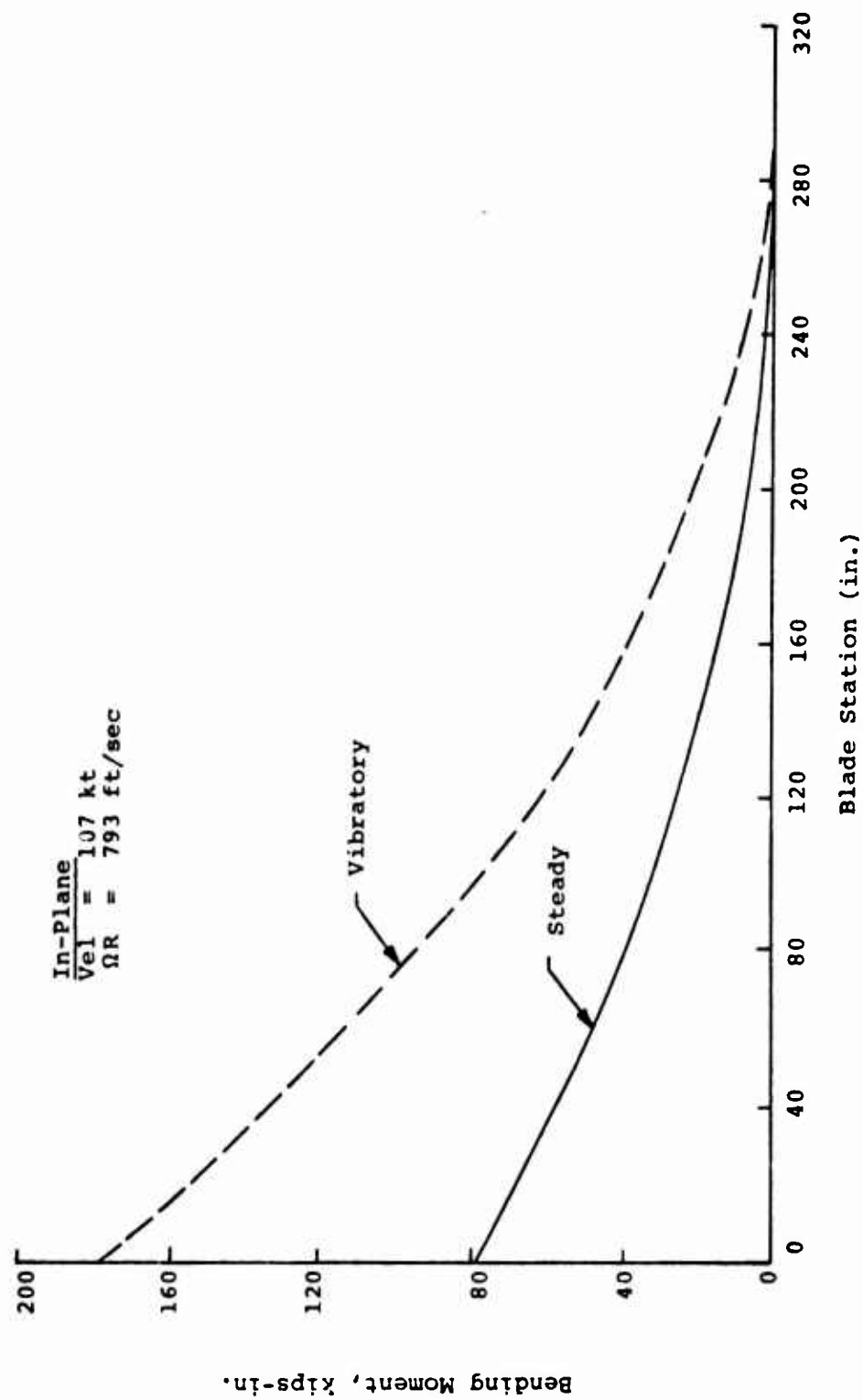

Figure 29. Dynamic Edgewise Bending Moments, Concept 2.

TABLE V. BASIC STRESS ANALYSIS SUMMARY

Configuration	Component (at station 81)	Coordinates (in.)		Fatigue Stress (ksi)	Margin of Safety	
		x*	y**			
Current UH-1H	Abrasion Strip	0.000	0.000	32.89	+ 7.11	+0.865
	Nose Weight	0.020	0.000	12.79	+ 2.76	+0.748
	Spar	0.677	0.542	12.74	+ 3.24	+0.491
	Skin	20.690	0.070	9.82	+ 6.14	+0.170
	Spline	21.000	0.027	9.77	+ 6.21	-0.179
Concept 1	Nose	0.000	0.000	11.80	+ 2.15	+0.925
	Nose	5.500	-1.257	11.81	+ 2.52	+1.051
	Nose	6.500	-1.205	11.63	+ 2.26	+0.843
	Skin	5.500	-1.257	4.89	+ 0.84	+3.269
	Skin	20.620	-0.043	3.68	+ 2.43	+0.513
	Spline	20.620	-0.043	8.89	+ 5.86	-0.216
Concept 2	Spline	21.000	-0.005	8.81	+ 5.95	-0.225
	Nose	0.000	0.000	12.51	+ 2.34	+0.717
	Nose	5.500	-1.253	12.51	+ 1.85	+1.175
	Nose	6.500	-1.237	12.32	+ 1.98	+1.044
	Skin	6.500	-1.237	5.10	+ 0.82	+3.318
	Skin	5.500	-1.253	5.18	+ 0.77	+3.618
Concept 3	Spline	21.000	-0.005	8.86	+ 6.14	-0.251
	Spline	20.620	-0.056	8.97	+ 6.06	-0.243
	Nose	0.000	0.000	31.03	+ 7.13	+0.480
	Nose	4.940	-1.260	30.71	+ 6.09	+0.747
	Skin	4.940	-1.260	4.66	+ 0.92	+2.879
	Spline	21.000	-0.028	3.20	+ 2.43	+0.528
Concept 3	Spline	21.000	-0.005	6.04	+ 4.57	+0.283

TABLE V - Continued

Configurator	Component (at station 81)	Coordinates $\frac{x^*}{y^{**}}$ (in.)	Fatigue Stress (ksi)	Margin of Safety
Concept 4	Nose	0.000	34.82	+ 7.88
	Nose	4.940	34.35	+ 6.72
	Skin	4.940	5.22	+ 1.02
	Skin	21.000	3.79	+ 2.30
	Spline	21.000	7.16	+ 4.32
Concept 5	Nose	0.000	30.46	+ 6.91
	Nose	4.940	30.12	+ 5.69
	Skin	4.940	4.57	+ 0.86
	Skin	21.000	3.15	+ 2.39
	Spline	21.000	5.94	+ 4.54
Concept 6	Nose	0.000	32.27	+ 7.65
	Nose	4.940	31.82	+ 6.38
	Skin	4.940	4.83	+ 0.97
	Skin	21.000	3.44	+ 2.26
	Spline	21.000	6.48	+ 4.29

\* X is measured from the leading edge parallel to the chord plane.

\*\* Y is measured from the chord plane and perpendicular to it.

station for Concepts 1 through 6, and the stresses obtained by a similar computation for the current blade are included for comparison.

#### RADAR CROSS SECTION

The program goal is to establish that the proposed repairable/expendable blade designs have a radar cross section (RCS) no larger than the UH-1H metal reference blade. Measured data generated from models with dimensions and characteristics of the UH-1H and Concept 2 blades are utilized as an aid to analysis of the current designs. Comparisons of the measured results are made that show the leading edge to be the prime contributor of the UH-1H metal blade. Measured data analysis also shows that the fiberglass blade aft section exposes the metal spar to the extent that the trailing edge becomes the most significant contributor and must be treated. Theoretical and measured results are utilized to show that the increased leading-edge radius of Concepts 1 and 3 may be used without increasing the RCS above the required reference level. Practical approaches to reduction of the trailing-edge RCS of the fiberglass designs to that of the required reference level are presented.

Appendix IV presents the radar cross section study performed on field-repairable/expendable rotor blade Concepts 1 through 4. With respect to radar reflectivity characteristics, Concepts 7, 9, and 11 are the same as Concept 1, Concepts 8, 10, and 12 as Concept 2, Concept 5 as Concept 3, and Concept 6 as Concept 4.

#### ACOUSTIC SIGNATURE

Because all the field-repairable/expendable rotor blade concepts are aerodynamically similar to the current blade, with the exception of the airfoil section, the evaluation of acoustic signature becomes dependent on the characteristics of the simplified airfoil. In this section, those concepts (1, 3, 5, 7, 9, and 11) with the modified airfoil section are identified as Type II, while the even-numbered concepts with the standard NACA 0012 airfoil are Type I.

The external noise signature of the UH-1 helicopter is made up of contributions from the main rotor, tail rotor, engine, and drive systems. Noise produced by these components is distributed throughout the audible spectrum, with the main rotor contributing in the very low frequency range (10 Hz - 100 Hz), the tail rotor contributing in the low to mid frequency range (55 - 500 Hz), and the remaining sources contributing

mainly above 500 Hz\*. Regarding aural detectability, only the main and tail rotor noise components are of consequence.

Factors which determine the distance at which a noise source will be detected (i.e., its aural detection range) include:

- The amplitude/frequency characteristics of the source.
- The propagation characteristics of the medium through which the sound signal travels.
- The amplitude/frequency characteristics of masking noise in the vicinity of the observer.
- The frequency response of the observer's ear.

For cases of interest\*\*, these factors combine in such a way as to make the aural detection range of the UH-1 most sensitive to the amplitude of high-frequency (third through tenth harmonic of blade passage frequency) main rotor and low-frequency (fundamental through second harmonic of blade passage frequency) tail rotor noise. Factors which increase these noise components will tend to increase aural detection range, with the actual magnitude dependent on the factors mentioned previously\*\*\*.

The noise source (tail or main rotor) which contributes most to UH-1 aural detectability is determined primarily by the forward velocity of the aircraft. As airspeed increases, the relative magnitude of higher harmonic main rotor noise increases. In addition, this noise component becomes more directional, with increasing radiation in the forward direction. For these reasons, in most cases, an approaching UH-1, operating at

---

\* This analysis of UH-1 noise sources is based on Figure 8 of Reference 8, which shows significant tail rotor rotational noise at and above the fundamental (N-per-rev) of tail rotor blade passage frequency.

\*\* For example, propagation at low altitude, over medium-density ground cover, through still air, in the presence of low ambient noise, with detection by the unaided ear.

\*\*\*A more detailed discussion of the aural detectability of helicopters is given in Reference 9, along with specific procedures for estimating detection range.

moderate to high speed (80 to 120 kt), will be initially detected through its rotor noise component. Factors which increase higher harmonic rotor noise have a detrimental effect on aural detectability.

Helicopter main rotor noise is produced through a number of mechanisms. The primary mechanism, at least with respect to the generation of higher harmonic rotational noise, and consequently aural detectability, is the acoustic dipole resulting from the fluctuating lift, drag and radial forces applied to the air by the rotor blades (Reference 8). Factors which influence the generation of this noise component include rotor blade parameters, such as blade airfoil section, planform, twist distribution, thickness distribution, and blade dynamics, as well as such operating parameters as steady lift (A/C gross weight), rotor speed, and A/C forward speed.

For the UH-1 operating at moderate to high airspeed, the magnitude of higher harmonic rotor noise is dependent, primarily, on the magnitude of drag forces generated by the advancing blade. This situation arises because the standard UH-1 rotor system operates at a very high advancing blade tip Mach number, well in excess of the drag divergence Mach number for moderate- to high-speed flight\*.

Based on the above discussions, the impact of field-repairable/expendable blade (FREB) modifications on the aural detectability of the UH-1 may be qualitatively assessed by evaluating the impact of these modifications on high Mach number drag characteristics. Of the two FREB designs, only the Type II blade, which has a slightly different airfoil section than the NACA 0012 section used on the standard UH-1, will have differing high Mach number drag characteristics. The Type I FREB, utilizing a standard NACA 0012 airfoil section, will have identical drag characteristics as the standard UH-1 blade; consequently, the use of the Type I FREB design will result in no change in the aural detectability of the aircraft.

Evaluation of the Type II FREB airfoil section indicates that this design will result in a reduction in zero-angle-of-attack drag divergence Mach number. Increased section thickness forward of the quarter chord, coupled with an increase in nose radius, results in the modified airfoil pressure distribution

---

\* The drag divergence Mach number for a 0012 airfoil at zero angle of attack is approximately .78. This is exceeded by the UH-1 rotor, at the advancing blade tip, at 50 knots.

(relative to an NACA 0012 section) shown in Figure 30. As indicated in this figure, the pressure distribution of the Type II FREB section is nearly identical to that of a standard NACA 0015 airfoil forward of the maximum thickness point. By analogy to the NACA 0015 section characteristics, given in Reference 10, a 5% decrease in zero-angle-of-attack drag divergence Mach number is indicated for the Type II FREB relative to the standard UH-1 blade.

The impact of the decreased drag divergence Mach number on UH-1 aural detectability is illustrated in Figure 31. Shown are constant aural detection range contours, as functions of rotor speed (rpm) and airspeed, for the UH-1 with standard (NACA 0012) blades, FREB Type I and FREB Type II. This figure indicates that a UH-1 utilizing a Type II FREB rotor, and required to have no greater aural detection range than a standard-rotor-equipped UH-1, would be required to operate either with a rotor speed reduction of 5% or at a 25% reduced airspeed. Requiring a constant detection time would dictate a reduction in rotor speed, since operation at a reduced airspeed will cause increased warning time, even with constant aural detection range.

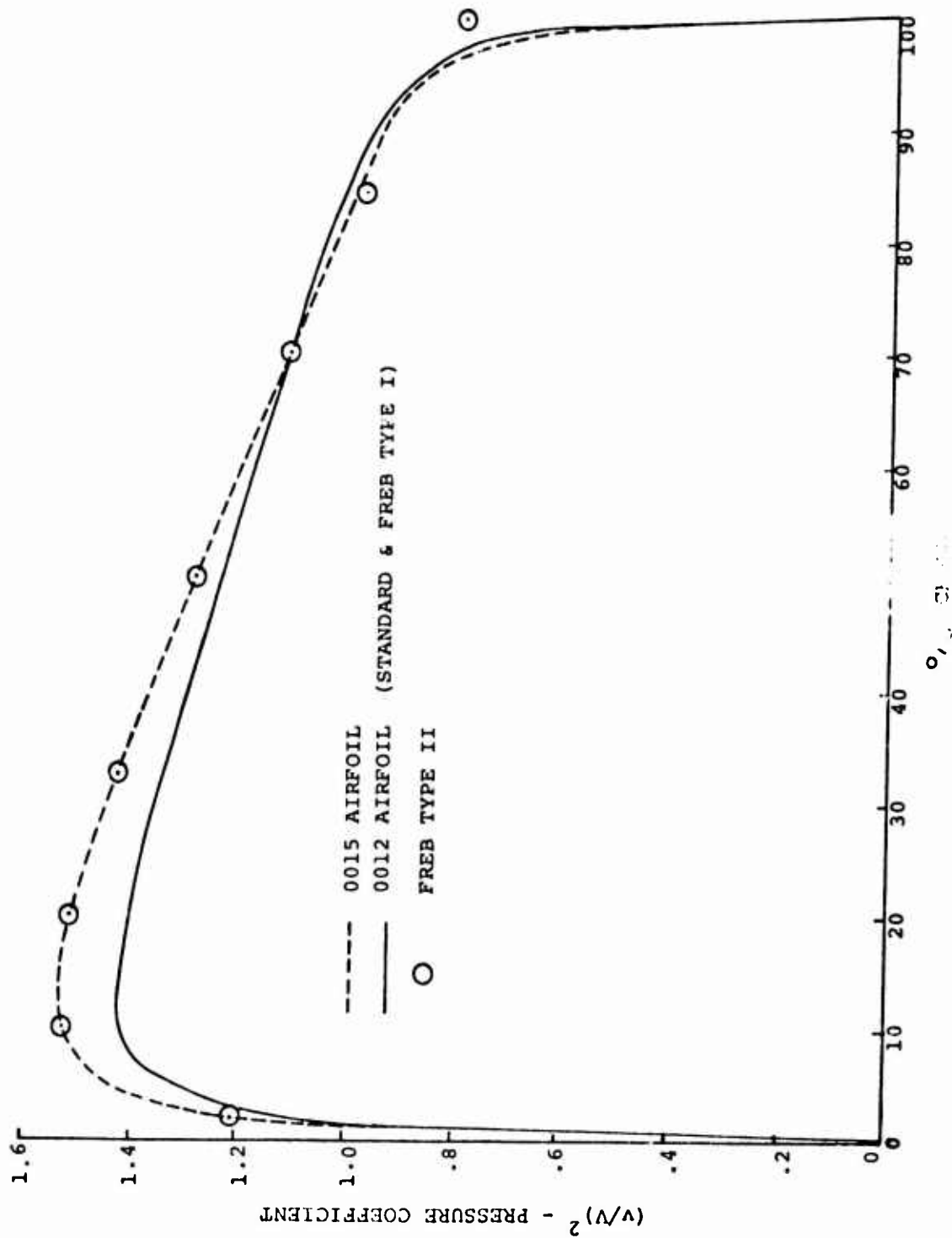

Figure 30. Airfoil Pressure Distribution for 0015, 0012, and FRED Type II Airfoils.

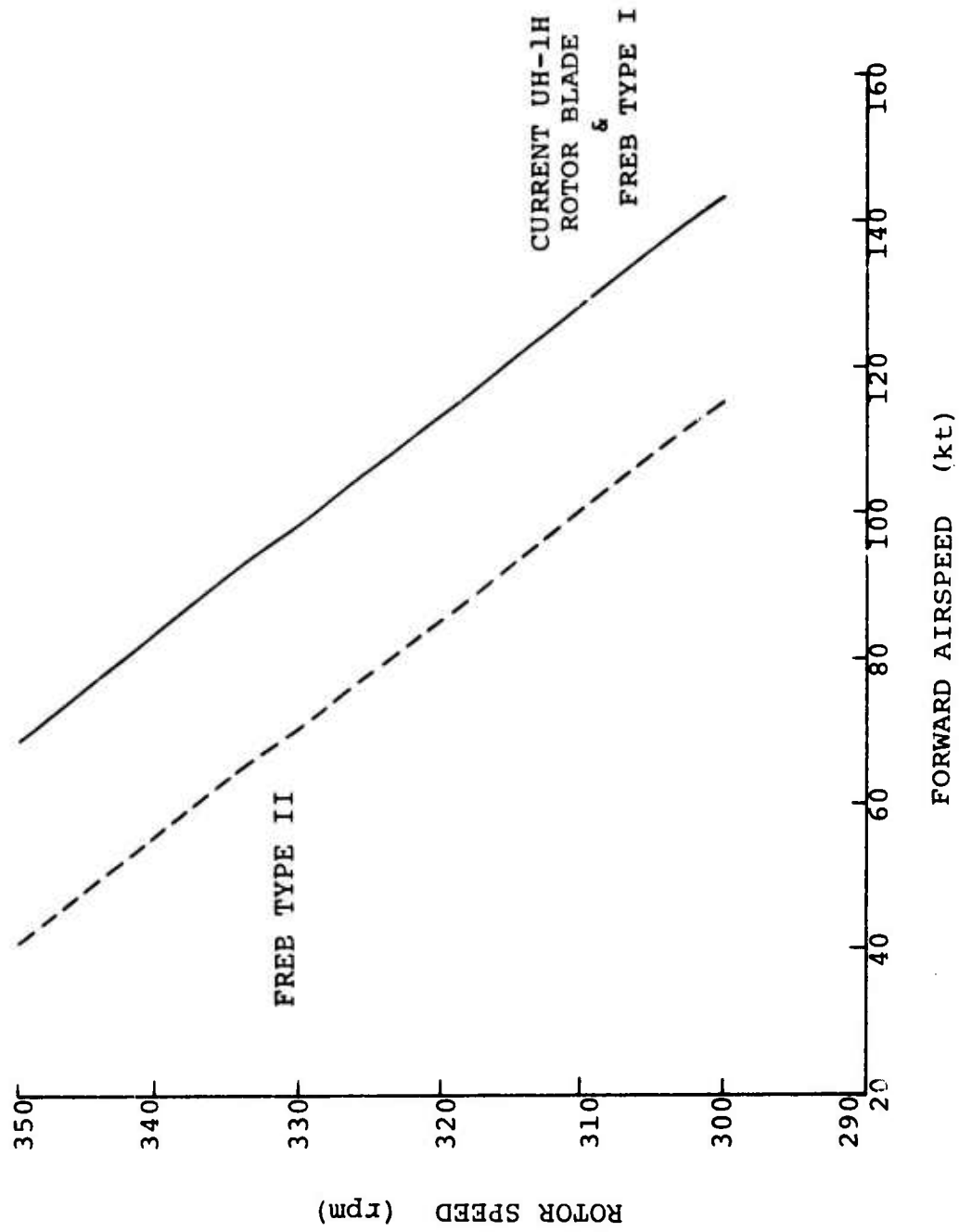

Figure 31. Rotor Speed vs. Forward Airspeed for Constant Aural Detection Range.

## RELIABILITY AND MAINTAINABILITY

Throughout the preliminary design phase, analyses of the anticipated failures, and their modes and rates of occurrence, were performed as the concepts evolved. As these potential failures were identified, maintainability analyses were performed to determine dispositions (repair or scrap); and for those damage events expected to be repairable, labor effort, material costs, and elapsed times were determined for each repair.

From the reliability and maintainability standpoint, the twelve concepts can be divided into two groups: those having aluminum spars and those having stainless steel spars. Concept 1 is representative of all the former group, while Concept 3 is representative of all the latter. Subsequent to these basic analyses, minor adjustments were made to account for detail differences within the groups. For example, Concept 1 was analyzed as if it had a separate abrasion sheath, so this analysis is truly representative of Concepts 7 and 8 only.

For Concepts 1, 2, 9, 10, 11, and 12, those failures associated with the leading edge were either eliminated (e.g., delaminations) or applied to the spar (e.g., nicks and scratches), as appropriate. Concepts 4 and 6 finally evolved with narrower chord spars than Concepts 3 and 5, so the skin damage occurrences were increased, and the spar damage decreased, in proportion to the change in area.

Concepts 11 and 12 present a special case, since no operational experience has been acquired with plastic skins reinforced by PRD-49. The characteristics of the fiber indicate that a reduction of as much as 50% in the incidence of skin damage might be expected. The life-cycle cost analysis was performed on this basis. For a greater incidence of skin failures, the life-cycle costs will increase appropriately.

As the failure modes and maintainability analyses developed, the results were incorporated into a computer program which provided the necessary averages for input to the life-cycle cost analysis and also determined the 95<sup>th</sup> percentile maximum repair times. For this maximum time calculation, the equations developed in Appendix III were applied only to the labor time to effect a repair. Adhesive cure time was regarded as an invariable book value, such that any variations were chargeable to some other activity (e.g., the mechanic working on another aircraft at the time the adhesive was fully cured), while the man-hours to remove and replace a blade were defined by the contract. The output from these computer analyses of failure

modes and effects, dispositions, and maintenance activities is presented in Appendix V.

#### FAILURE MODES AND EFFECTS

The analysis methodology developed previously and used in the design studies of repairable and expendable main rotor blades, References 2 and 3 respectively, has been applied here in performing the failure modes and effects analysis for candidate field-repairable/expendable main rotor blade design concepts. This methodology was refined and updated to include definitions of primary and secondary failures resulting from single incidents, hazard level of each incident as defined in MIL-STD-882, and expected rates of occurrence based on the latest available experience data. As before, the cause, effect, and ultimate disposition of each failure mode have been included in the analysis.

Failure modes are divided into three categories: inherent, external, and combat. In References 2 and 3, combat damage causes were included in the external cause category. Segregating combat damage into a category of its own, however, aids in determining the reliability of a given blade design in other, noncombat environments, even though the combat environment is a specific requirement of this study program.

Frequency of occurrence of inherent failure modes for the candidate field-repairable/expendable main rotor blade design concepts relative to the current UH-1H main rotor blade can be determined using the inherent failure rate data reported in Reference 3. Similarly, the relative frequency of occurrence of external and combat failure modes can be estimated by application of the damage scenario to the various blade design concepts, adjusting the depth of dents, tears and foreign-object damage according to the material of the affected blade parts as described in Reference 2. The failure effects data of References 2 and 3 also provide a basis for evaluating the hazard classification of similar failure modes for the candidate blade designs.

Field experience gained with UH-1H rotor blades and reported in Reference 1 serves as the basic data source for the failure modes and effects analysis of the current main rotor blade. Various samples of the UH-1H blade were collected, analyzed and reported in Reference 1, giving the best available values of failure mode occurrences and proportions attributable to different causes. Table D-I of Reference 1 lists the total of all known failure causes grouped into five inherent and five external failure subcategories. These data, with the

inherent and external failure fractions adjusted to conform with the values shown in Table H-I of Reference 1, define the total spectrum of failure modes considered in this analysis. All failure causes reported within the excessive vibration subcategory of the Table D-I inherent causes were assumed to be secondary failures, and corresponding primary failures were assigned to each of these based on the inherent failure cause data of Reference 3. All inherent and external failures were apportioned among the various causes as indicated by their frequency of occurrence in Table D-I. The failure description and location data of Reference 3 were then used to apportion these failures among the major elements of the rotor blade.

The application of the damage scenario to the current UH-1H main rotor blade, as reported in Reference 2, apportioned the damage events among the dent, puncture, tear, foreign object and battle damage classifications. The same apportionment and damage classifications have been applied to the total number of failures within the foreign-object damage subcategory of the adjusted data of Table D-I of Reference 1, thus integrating the damage scenario results into the failure modes and effects analysis.

The complete failure modes and effects analysis for the current UH-1H rotor blade is tabulated in Table VI. Similar analyses have been prepared for candidate field-repairable/expendable main rotor blade designs using the current blade data. Inherent failure mode rates of occurrence for candidate designs have been computed from the current blade failure data using the ratio of inherent failure rates for candidate blade component parts to inherent failure rates for current blade parts as presented in Reference 3. External and battle damage failure mode rates of occurrence have been determined from the application of the damage scenario to candidate blade component parts using the data given in Reference 2 for the same blade components.

Tables VII and VIII detail the results of the failure modes and effects analyses for field-repairable/expendable main rotor blade Concepts 1 and 3. Note that these concepts incorporate straight-sided airfoil shapes while Concepts 2 and 4 have curved airfoil shapes. In all other respects, Concepts 1 and 2 are identical, as are Concepts 3 and 4. Since this design variation will have only a minor effect on failure modes and rates of occurrence, separate failure modes and effects analyses have not been prepared for Concepts 2 and 4.

Failure rate summaries for the current UH-1H main rotor blade

**TABLE VI. FAILURE RATE COMPUTATIONS,  
CURRENT UH-1H BLADE**

Failure Mode	Component or Location	Number of Failures	Failure Rate	MTBF <sup>**</sup>
<b>Inherent causes</b>				
Primary failures		2206	280.48	3,565
Bond failure/ Delamination	Subtotal	952	121.04	8,262
	Skin/Spar	84	10.68	93,631
	Spline/Skin	80	10.17	98,313
	Skin/Core	594	75.52	13,241
	Spar/Noseblock	20	2.543	393,250
	Abrasion sheath/LE	104	13.22	75,625
	Root end	49	6.230	160,510
	Spar/Core	21	2.670	374,524
Crack	Subtotal	658	83.66	11,953
	Spline	69	8.773	113,986
	Skin	567	72.09	13,871
	Root end	22	2.797	357,500
Corrosion	Subtotal	147	18.69	53,503
	Skin	65	8.264	121,000
	Spline	80	10.17	98,313
	Root end	2	0.254	3,932,500
Excessive wear	Subtotal	356	45.26	22,093
	Abrasion sheath	18	2.289	436,944
	Skin	30	3.814	262,167
	Spline	92	11.70	85,489
	Root end	216	27.46	36,412

TABLE VI - Continued

Failure Mode	Component or Location	Number of Failures	Failure Rate	MTBF <sub>N</sub>
Deterioration	Subtotal	93	11.82	84,570
	Abrasion sheath	26	3.306	302,500
	Skin	25	3.179	314,600
	Spline	9	1.144	873,889
	Root end	33	4.196	238,333
Secondary failures				
Excessive vibration	Subtotal	536	68.15	14,674
	Skin/Core BF/Delam.	281	35.73	27,989
	Skin/Spar BF/Delam.	15	1.907	524,333
	Spline/Skin BF/Delam.	15	1.907	524,333
	Noseblock/Spar BF/D.	20	2.543	393,250
	Abrasion sheath/L E BF/Delamination	93	11.82	84,570
	Root end BF/Delam.	36	4.577	218,472
	Root end excessive wear	30	3.814	262,167
	Skin crack	31	3.942	253,710
	Spline corrosion	15	1.907	524,333
External causes		4200	534.01	1,872.6
Dent	Subtotal	1846	234.71	4,260.6
	Abrasion sheath /Spar doubler /Skin /Core	246	31.28	31,972
	Abrasion sheath	246	31.28	31,972
	Skin /Grip doublers Root fitting	62	7.883	126,855
	Skin /Grip doublers	61	7.756	128,934

TABLE VI - Continued

Failure Mode	Component or Location	Number of Failures	Failure Rate	MTBF <sub>N</sub>
Dent, continued	Skin/ Core/ Grip doublers	185	23.52	42,514
	Skin/ Core	246	31.28	31,972
	Skin/ Core/ Spline	492	62.56	15,986
	Skin/ Core/ Spline/ Link	62	7.883	126,855
	Skin /Spline	185	23.52	42,514
	Spline	61	7.756	128,934
Puncture	Subtotal	677	86.08	11,617
	Abrasion sheath/ Spar doubler /Spar	123	15.64	63,943
	Abrasion sheath/ Nose-block	62	7.883	126,855
	Spar doubler /Spar/ Grip doublers	62	7.883	126,855
	Skin /Core	369	46.92	21,314
	Skin /Spline	61	7.756	128,934
Foreign-object damage	Subtotal	554	70.44	14,197
	Abrasion sheath/ Spar doubler / Skin /Core	62	7.883	126,855
	Abrasion sheath/ Grip doublers	61	7.756	128,934
	Abrasion sheath	123	15.64	63,943
	Skin /Core	246	31.28	31,972
	Skin /Core/ Spline	62	7.883	126,855

TABLE VI - Continued

Failure Mode	Component or Location	Number of Failures	Failure Rate	MTBF <sub>N</sub>
Tear	Subtotal	370	47.04	21,257
	Abrasion sheath/Spar doubler /Skin/ Core	62	7.883	126,855
	Abrasion sheath	185	23.52	42,514
	Skin/ Core	123	15.64	63,943
Overstressed	Total blade	733	93.20	10,730
Blistered/Burned	Total blade	15	1.907	524,333
Indirect causes	Total blade	5	0.636	1,573,000
Combat causes				
Battle damage	Subtotal	923	117.36	8,521.1
	Skin/ Core/ Grip doublers	62	7.883	126,855
	Skin /Core	492	62.56	15,986
	Skin/ Core/ Spline	62	7.883	126,855
	Skin/ Spline	123	15.64	63,943
	Spline	61	7.756	128,934
	Abrasion sheath/Spar doubler /Spar	123	15.64	63,943
<p>* Failure rate is in units of number of failures per 10<sup>6</sup> blade-hours.</p> <p>** MTBF is in units of blade-hours.</p>				

TABLE VII. FAILURE RATE COMPUTATIONS,  
CONCEPT 1.

Failure Mode	Component or Location	Number of Failures	Failure Rate*	MTBFN**
Inherent causes				
Primary failures				
Bond failure/ Delamination		1496	190.21	5,257
	Subtotal	530	67.39	14,840
	Skin/Spar	31	3.942	253,710
	Spline/Skin	78	9.917	100,833
	Skin/Core	382	46.57	20,589
	Abrasion sheath/L E	16	2.034	491,563
	Root end	17	2.161	462,647
	Spar/Core	6	0.763	1,310,833
Cracks				
	Subtotal	328	41.70	23,979
	Spline	70	8.900	112,357
	Skin	228	28.99	34,496
	Root end	25	3.179	314,600
	Spar	5	0.636	1,573,000
Corrosion				
	Subtotal	197	25.05	39,924
	Spar	139	17.67	56,583
	Skin	14	1.780	561,786
	Spline	43	5.467	182,907
	Root end	1	0.127	7,865,000
Excessive wear				
	Subtotal	350	44.50	22,471
	Spar	120	15.26	65,542
	Skin	3	0.381	2,621,667
	Spline	40	5.086	196,625
	Root end	187	23.78	42,059

TABLE VII - Continued

Failure Mode	Component or Location	Number of Failures	Failure Rate	MTBF <sub>N</sub>
Deterioration	Subtotal	91	11.57	86,429
	Spar	50	6.357	157,300
	Skin	3	0.381	2,621,667
	Spline	5	0.636	1,573,000
	Root end	33	4.196	238,333
Secondary failures				
Excessive vibration	Subtotal	310	39.42	25,371
	Skin/Core BF/Delam.	205	26.06	38,366
	Spline/Skin BF/Delam.	15	1.907	524,333
	Abrasion sheath/Spar BF/Delam.	11	1.399	715,000
	Root end BF/Delam.	11	1.399	715,000
	Root end excessive wear	29	3.687	271,207
	Spar crack	5	0.636	1,573,000
	Skin crack	15	1.907	524,333
	Root end crack	3	0.381	2,621,667
	Spline crack	1	0.127	7,865,000
	Spline corrosion	15	1.907	524,333
	External causes		4243	539.48
Dent	Subtotal	1846	234.71	4,26056
	Abrasion sheath	62	7.883	126,855
	Abrasion sheath / Spar / Skin core	62	7.883	126,855
	Spar / Skin / Core	185	23.52	42,514

TABLE VII - Continued

Failure Mode	Component or Location	Number of Failures	Failure Rate	MTBF <sub>N</sub>
Dent, continued	Spar	185	23.52	42,514
	Skin/Grip doublers/ Root fitting	61	7.756	128,934
	Skin/Grip doublers	61	7.756	128,934
	Skin/Core/Grip doublers	185	23.52	42,514
	Skin/Core	246	31.28	31,972
	Skin/Core/Spline	615	78.19	12,789
	Skin/Core/Spline/ Link	61	7.756	128,934
	Skin/Spline	61	7.756	128,934
	Spline	62	7.883	126,855
	Puncture	Subtotal	677	86.08
Abrasion sheath/ Spar		62	7.883	126,855
Spar		123	15.64	63,943
Spar/Grip doublers/ Skin		61	7.756	128,934
Skin/Core		369	46.92	21,314
Skin/Spline		62	7.883	126,855
Foreign-object damage		Subtotal	554	70.44
	Spar/Skin/Core	62	7.883	126,855
	Spar/Grip doublers	62	7.883	126,855
	Spar	123	15.64	63,943
	Skin/Core	246	31.28	31,972
	Skin/Core/Spline	61	7.756	128,934

TABLE VII - Continued

Failure Mode	Component or Location	Number of Failures	Failure Rate	MTBF <sub>N</sub>
Tear	Subtotal	370	47.04	21,257
	Spar /Skin /Core	62	7.883	126,855
	Spar	185	23.52	42,514
	Skin /Core	123	15.64	63,943
Overstressed	Total blade	776	98.66	10,135
Blistered/Burned	Total blade	15	1.907	524,333
Indirect causes	Total blade	5	0.636	157,300
Combat causes				
Battle damage	Subtotal	923	117.36	8,521
	Skir. /Core /Grip doublers	61	7.756	128,934
	Skin /Core	492	62.56	15,986
	Skin /Core /Spline	62	7.883	126,855
	Skin /Spline	123	15.64	63,943
	Spline	62	7.883	126,855
	Spar	123	15.64	63,943
* Failure rate is in units of number of failures per 10 <sup>6</sup> blade-hours.				
** MTBF is in units of blade-hours.				

**TABLE VIII. FAILURE RATE COMPUTATIONS,  
CONCEPT 3**

Failure Mode	Component or Location	Number of Failures	Failure Rate <sup>a</sup>	MTBF <sub>N</sub> <sup>**</sup>
<b>Inherent causes</b>				
Primary failures		1184	150.54	6,642.7
Bond failure/ Delamination	Subtotal	565	71.84	13,920
	Skin/Spar	69	8.773	113,986
	Spline/Skin	31	3.942	253,710
	Skin/Core	382	48.57	20,589
	Spar	58	7.374	135,603
	Root end	17	2.161	462,647
	Spar/Core	8	1.017	983,125
Crack	Subtotal	265	33.69	29,679
	Spline	0	-	-
	Skin	228	28.99	34,496
	Root end	23	2.924	341,957
	Spar	14	1.780	561,786
Corrosion	Subtotal	85	10.81	92,529
	Spar	42	5.340	187,262
	Skin	14	1.780	561,786
	Spline	28	3.560	280,893
	Root end	1	0.127	7,865,000
Excessive wear	Subtotal	210	26.70	37,452
	Spar	14	1.780	561,786
	Skin	3	0.381	2,621,667
	Spline	9	1.144	873,889
	Root end	184	23.39	42,745

TABLE VIII - Continued

Failure Mode	Component or Location	Number of Failures	Failure Rate	MTBF <sub>N</sub>
Deterioration	Subtotal	59	7.502	133,305
	Spar	2	0.254	3,932,500
	Skin	3	0.381	2,621,667
	Spline	22	2.797	357,500
	Root end	32	4.069	245,781
Secondary failures				
Excessive vibration	Subtotal	378	48.06	20,807
	Skin/Core BF/Delam.	205	26.06	38,366
	Skin/Spar BF/Delam.	65	8.264	121,000
	Spline/Skin BF/Delam.	10	1.271	786,500
	Spar BF/Delam.	30	3.814	262,167
	Root end BF/Delam.	10	1.271	786,500
	Root end excessive wear	26	3.306	302,500
	Spar crack	14	1.780	561,786
	Skin crack	15	1.907	524,333
	Spline crack	0	-	-
Root end crack	3	0.381		
External causes		4200	534.01	1,872.6
Dent	Subtotal	1846	234.71	4,020.6
	Spar	246	31.28	31,972
	Spar / Skin	185	23.52	42,514
	Spar / Skin / Core	62	7.883	126,855
	Spar / Grip doublers	185	23.52	42,514
	Spar / Grip doublers / Root fitting / Skin	61	7.756	128,934

TABLE VIII - Continued

Failure Mode	Component or Location	Number of Failures	Failure Rate	MTBF <sub>N</sub>
	Skin / Core/ Grip doublers	61	7.756	128,934
	Skin/Core	308	39.16	25,536
	Skin/Core/Spline	492	62.56	15,986
	Skin/Spline	185	23.52	42,514
Puncture	Subtotal	677	86.08	11,617
	Grip doublers/Spar	62	7.883	126,855
	Spar	185	23.52	42,514
	Spar/Skin	61	7.756	128,934
	Skin/Core	308	39.16	25,536
	Skin/Spline	61	7.756	128,934
Foreign-object damage	Subtotal	554	70.44	14,197
	Grip doublers/Spar	62	7.883	126,855
	Spar	185	23.52	42,514
	Spar/Skin	61	7.756	128,934
	Spar/Skin/Core	61	7.756	128,934
	Skin/Core	185	23.52	42,514
Tear	Subtotal	370	47.04	21,257
	Spar	185	23.52	42,514
	Spar/Skin	62	7.883	126,855
	Spar/Skin/Core	62	7.883	126,855
	Skin/Core	61	7.756	128,934
Overstressed	Total blade	733	93.20	10,730
Blistered/Burned	Total blade	15	1.907	524,333
Indirect causes	Total blade	5	0.636	1,573,000

TABLE VIII - Continued

Failure Mode	Component or Location	Number of Failures	Failure Rate	MTBF <sub>N</sub>
Combat causes				
Battle damage	Subtotal	923	117.36	8,521.1
	Grip doublers/ Skin/ Spar	61	7.756	128,934
	Spar	123	15.64	63,943
	Spar /Skin	185	23.52	42,514
	Skin /Core	308	39.16	25,536
	Skin /Spline	185	23.52	42,514
	Skin /Core /Spline	61	7.756	128,934
* Failure rate is in units of number of failures per 10 <sup>6</sup> blade-hours.				
** MTBF is in units of blade-hours.				

and Concepts 1 and 3 are presented in Tables IX, X, and XI respectively. Data are given for primary and secondary failures in the inherent, external and combat failure categories apportioned to the major elements of the blade and for the blade as a whole. The MTBF's experienced by the current blade and the predicted MTBF's for Concepts 1 and 3 are shown in Tables XII, XIII, and XIV apportioned in the same manner.

The field-repairable/expendable concepts exhibit significantly improved reliability compared to the current UH-1H main rotor blade. The predicted MTBF's for Concepts 1 and 3 are approximately 13- and 18-percent greater respectively than the MTBF experienced by the current blade.

#### MAINTENANCE ACTIONS AND TIMES

The possible dispositions of damage of each appropriate type to each component of the blade concepts are presented in Table XV for Concept 1 and its associated group, and in Table XVI for Concept 3 and its group.

Appendix VI gives the detail dispositions, maintenance times, and kit contents for each failure occurrence. These dispositions were used as inputs to the failure modes and effects computer analysis, the outputs from which are given in Appendix V. The adjustments within the groups, as described above, were made to the dispositions before being introduced to the analysis. Those damage occurrences requiring no maintenance action, such as a sheet metal dent below significant limits, were eliminated from consideration by the computer.

The computer analysis provided the ability to eliminate combat damage from the analysis. It is assumed that only those events listed as ballistic damage were attributable to the combat environment, and that elimination of these would alone be representative of peaceful operation. This is probably an underestimate.

Although it appears intuitively that it would be easier to apply a patch to a flat than to a curved surface, no hard experience is available for applying a quantified improvement to the repair times. No differentiation is made in the maintainability analysis between those concepts with the simplified airfoil section and those with the standard NACA 0012 airfoil.

Figures 32 through 36 depict the repair schemes devised for use with the field repairable/expendable blade concepts.

TABLE IX. FAILURE RATE SUMMARY, CURRENT UH-1H BLADE

Failure Classes	Abrasion Sheath	Spar	Skin & Core	Spline	Root End	Complete Blade	Blade Total
Inherent, Primary	18.82	15.89	162.87	41.96	40.94	-	280.48
Inherent, Secondary	11.82	4.45	39.67	3.81	8.39	-	68.15
Total Inherent	30.64	20.34	202.54	45.77	49.33	-	348.63
External, Primary	90.15	62.68	206.99	35.47	42.98	95.74	534.01
Combat Damage, Primary	7.88	7.76	74.38	19.45	7.88	-	117.36
Inherent & External, Primary	108.96	78.58	369.87	77.43	83.92	95.74	814.49
Inherent & External, Total	120.79	83.03	409.54	81.25	92.31	95.74	882.64
Inherent, External & Combat Damage, Primary	116.85	86.33	444.25	96.88	91.80	95.74	931.85
Inherent, External & Combat Damage, Total	128.67	90.78	483.92	100.70	100.19	95.74	1,000.00

TABLE X. FAILURE RATE SUMMARY, CONCEPT 1

Failure Classes	Abrasion Sheath	Spar	Skin & Core	Spline	Root End	Complete Blade	Blade Total
Inherent, Primary	2.03	44.63	80.10	30.01	33.44	-	190.21
Inherent, Secondary	1.40	0.64	27.97	3.94	5.47	-	39.42
Total Inherent	3.43	45.26	108.07	33.95	38.91	-	229.62
External, Primary	11.82	117.23	196.82	65.48	46.92	101.21	539.48
Combat Damage, Primary	-	15.64	74.38	19.58	7.76	-	117.36
Inherent & External, Primary	13.86	161.86	276.92	95.49	80.36	101.21	729.63
Inherent & External, Total	15.26	162.49	304.90	99.43	85.82	101.21	769.10
Inherent, External & Combat Damage, Primary	13.86	177.50	351.30	115.07	88.11	101.21	847.04
Inherent, External & Combat Damage, Total	15.26	178.13	379.28	119.01	93.58	101.21	886.46

TABLE XI. FAILURE RATE SUMMARY, CONCEPT 3

Failure Classes	Abrasion Sheath	Spar	Skin & Core	Spline	Root End	Complete Blade	Blade Total
Inherent, Primary	-	21.87	86.59	9.409	32.68	-	150.54
Inherent, Secondary	-	9.663	32.17	1.271	4.959	-	48.06
Total Inherent	-	31.53	118.75	10.68	37.64	-	198.60
External, Primary	-	161.47	200.76	47.04	28.99	95.74	534.01
Combat Damage, Primary	-	29.88	69.17	15.77	2.543	-	117.36
Inherent & External, Primary	-	183.34	287.35	56.45	61.67	95.74	684.55
Inherent & External, Total	-	193.01	319.52	57.72	66.62	95.74	732.61
Inherent, External & Combat Damage, Primary	-	213.22	356.52	72.22	64.21	95.74	801.91
Inherent, External & Combat Damage, Total	-	222.89	388.68	73.49	69.17	95.74	849.97

TABLE XII. MTBF SUMMARY, CURRENT UH-1H BLADE

Failure Classes	Abrasion Sheath	Spar	Skin & Core	Spline	Root End	Complete Blade	Blade Total
Inherent, Primary	53,142	62,920	6,139.7	23,833	24,425	-	3,565.3
Inherent, Secondary	84,570	224,714	25,208	262,167	119,167	-	14,674
Total Inherent	32,635	49,156	4,937.2	21,847	20,271	-	2,868.3
External, Primary	11,093	15,953	4,831.1	28,190	23,269	10,445	1,872.6
Combat Damage, Primary	126,855	128,934	13,444	51,405	126,855	-	8,521.1
Inherent & External, Primary	9,177.4	12,727	2,703.7	12,915	11,917	10,445	1,227.8
Inherent & External, Total	8,278.9	12,044	2,441.8	12,308	10,833	10,445	1,133.0
Inherent, External & Combat Damage, Primary	8,558.2	11,583	2,251.0	10,322	10,893	10,445	1,073.1
Inherent, External & Combat Damage, Total	7,771.7	11,015	2,066.5	9,930.6	9,981.0	10,445	1,000.0

TABLE XIII. MTBF SUMMARY, CONCEPT 1

Failure Classes	Abrasion Sheath	Spar	Skin & Core	Spline	Root End	Complete Blade	Blade Total
Inherent, Primary	491,563	22,407	12,484	33,326	29,905	-	5,257.4
Inherent, Secondary	715,000	1,573,000	35,750	253,710	182,907	-	25,371
Total Inherent	291,296	22,093	9,252.9	29,457	25,703	-	4,354.9
External, Primary	84,570	8,530.4	5,080.8	15,272	21,314	9,880.7	1,853.6
Combat Damage, Primary	-	63,943	13,444	51,071	128,934	-	8,521.1
Inherent & External, Primary	72,156	6,178.3	3,611.1	10,473	12,445	-	1,370.4
Inherent & External, Total	65,542	6,154.1	3,279.8	10,058	11,652	9,880.7	1,300.2
Inherent, External & Combat Damage, Primary	72,156	5,634.0	2,846.5	8,690.6	11,349	9,880.7	1,190.6
Inherent, External & Combat Damage, Total	65,542	5,613.8	2,636.6	8,402.8	10,686	9,860.7	1,128.1

TABLE XIII. MTBF SUMMARY, CONCEPT 1

Failure Classes	Abrasion Sheath	Spar	Skin & Core	Spline	Root End	Complete Blade	Blade Total
Inherent, Primary	491,563	22,407	12,484	33,326	29,905	-	5,257.4
Inherent, Secondary	715,000	1,573,000	35,750	253,710	182,907	-	25,371
Total Inherent	291,296	22,093	9,252.9	29,457	25,703	-	4,354.9
External, Primary	84,570	8,530.4	5,080.8	15,272	21,314	9,880.7	1,853.6
Combat Damage, Primary	-	63,943	13,444	51,071	123,934	-	8,521.1
Inherent & External, Primary	72,156	6,178.3	3,611.1	10,473	12,445	-	1,370.4
Inherent & External, Total	65,542	6,154.1	3,279.8	10,058	11,652	9,880.7	1,300.2
Inherent, External & Combat Damage, Primary	72,156	5,634.0	2,846.5	8,690.6	11,349	9,880.7	1,180.6
Inherent, External & Combat Damage, Total	65,542	5,613.8	2,636.6	8,402.8	10,686	9,880.7	1,128.1

TABLE XIV. MTBF SUMMARY, CONCEPT 3

Failure Classes	Abrasion Sheath	Spar	Skin & Core	Spline	Root End	Complete Blade	Blade Total
Inherent, Primary	-	45,727	11,549	106,284	30,603	-	6,642.7
Inherent, Secondary	-	103,487	31,087	786,500	201,667	-	20,807
Total Inherent	-	31,714	8,420.8	93,631	26,571	-	5,035.2
External, Primary	-	6,192.9	4,981.0	21,257	34,496	10,445	1,872.6
Combat Damage, Primary	-	33,468	14,458	63,427	393,250	-	8,521.1
Inherent & External, Primary	-	5,454.2	3,480.1	17,714	16,216	10,445	1,460.8
Inherent & External, Total	-	5,181.2	3,129.7	17,324	15,010	10,445	1,365.0
Inherent, External & Combat Damage, Primary	-	4,689.9	2,804.9	13,847	15,574	10,445	1,247.0
Inherent, External & Combat Damage, Total	-	4,486.6	2,572.8	13,607	14,458	10,445	1,176.5

TABLE XV. POTENTIAL DAMAGES AND MAINTENANCE ACTIONS,  
CONCEPT 1

Blade Detail	1	2	3	4	5	6	7	8	9	10
	Cracked	Bent, Distorted	Punctured, Torn	Delaminated	Dented	Corroded	Eroded	Nicked, Scratched	Worn Oversize	Loose or Missing Hardware
A Abrasion sheath (Polyurethane tape)			I	I			I	I		
B Spar (Aluminum)	S	S	S	S	A	R	A	A R		
C Skin (Fiberglass)	R		R	R	A			A R		
D Core (Nomex)			R		A R					
E T E Spline (Aluminum)	S	S	S	S	A R	R		R		
F Trim tab (Aluminum)	I	I R	I	I	A I	I R		I R		
G Root doublers (Aluminum)	S		S	S	S	R		R		
H Grip & drag plates (Aluminum)	S		S	S	S	R		R		
I Grip pad (Steel)	S		S	S		R		R		
J Grip & drag bushings (Steel)	S					R		R	S	
K Root closure (Aluminum)	S		S	S	A	R		R		
L Tip closure (Fiberglass)	R		R	S	A			A R		
M Root cap (Aluminum)	I		I		I	I R		I R		R
N Tip cap (Aluminum)	I	I	I		I	I R A		I R		R

Codes: A = Acceptable as is (if within limits)  
R = Repair (if within limits)  
I = Install replacement detail  
S = Scrap rotor blade

**TABLE XVI. POTENTIAL DAMAGES AND MAINTENANCE  
ACTIONS, CONCEPT 3**

	1	2	3	4	5	6	7	8	9	10
Blade Detail	Cracked	Bent, Distorted	Punctured, Torn	Delaminated	Dented	Corroded	Eroded	Nicked, Scratched	Worn Oversize	LOOSE OR MISSING Hardware
A Abrasion sheath (None used)										
B Spar (Stainless)	S	S	S	S	A		A	R		
C Skin (Fiberglass)	R		R	R	A			A R		
D Core (None:)			R		A R					
F T F Spline (Fiberglass)	S	S	S	S						
F Trim tab (Aluminum)	I	I R	I	I	A I	I R		I R		
G Root doublers (Stainless)	S		S	S	S			R		
H Grip & drag plates (Aluminum)	S		S	S	S	R		R		
I Grip pad (Steel)	S		S	S		R		R		
J Grip & drag bushings (Steel)	S					R		R	S	
K Root closure (Stainless)	S		S	S	A			A		
L Tip closure (Fiberglass)	R		R	S	A			A R		
M Root cap (Stainless)	I		I		I			A		R
N Tip cap (Aluminum)	I	I	I		I	I	R A I	A R I		R

Codes: A = Acceptable as is (if within limits)  
R = Repair (if within limits)  
I = Install replacement detail  
S = Scrap rotor blade

The use of reinforced plastic skins and nonmetallic honeycomb core can be seen to be an integral part of the overall repairability of the blade concepts. The maintenance analyses and maintainability predictions performed in Appendix VI, and used in the estimates of operational costs, use these preliminary schemes as a basis.

The repair schemes shown in Figures 32 through 36 are preliminary in nature, as appropriate to the preliminary design phase. Subsequent phases of the program will include detail design of the repair schemes, the appropriate kits, and the equipment required. Stress analyses will give final definition to the repair limits.

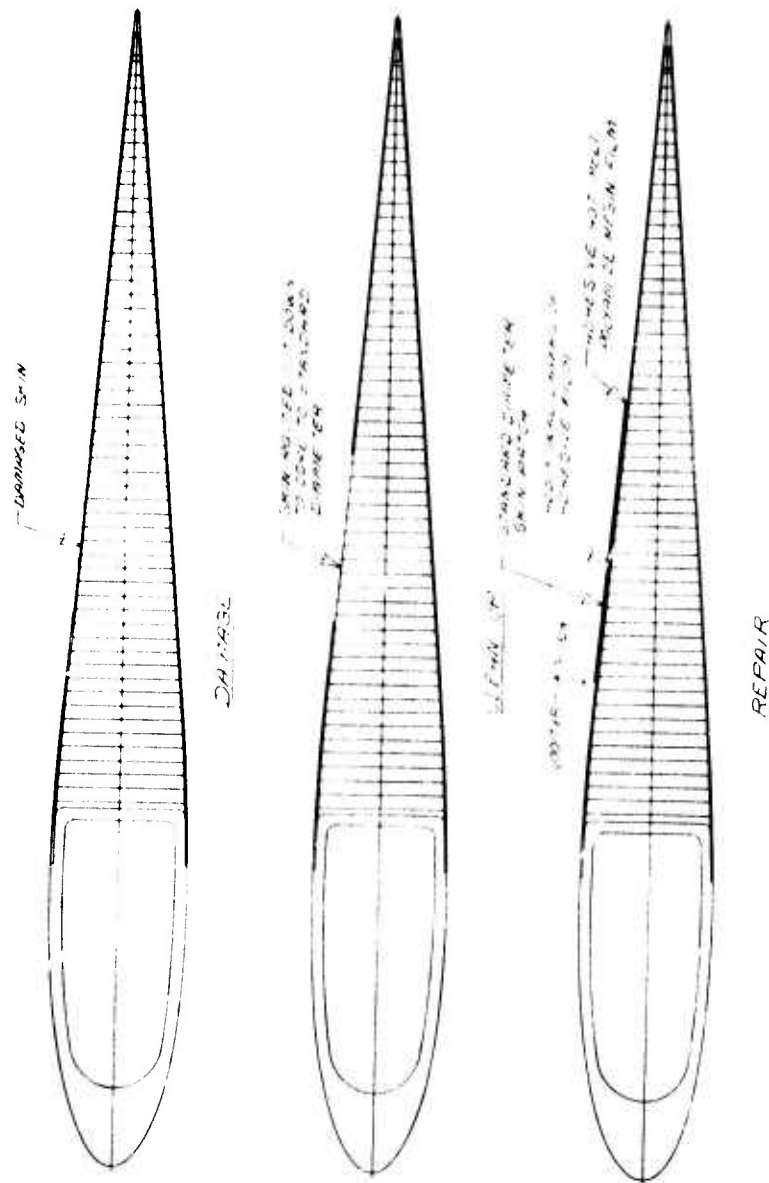

Figure 32. Field Repair Scheme, Skin Patch.

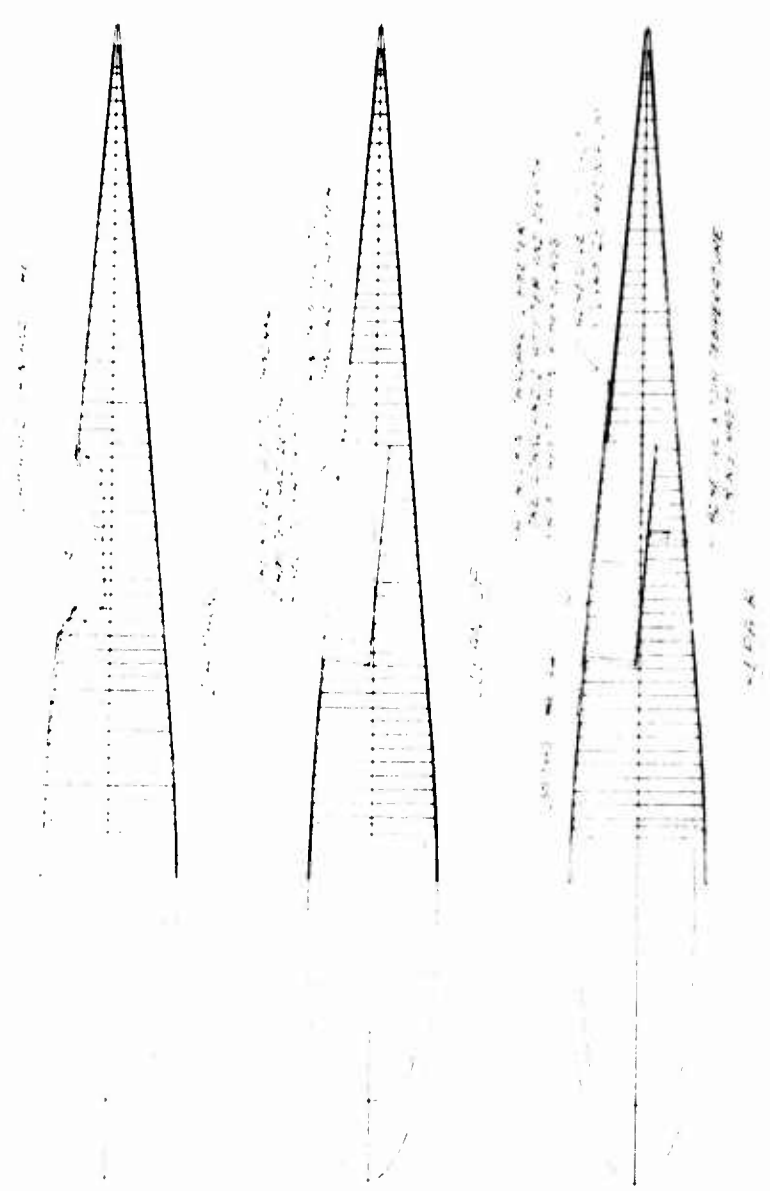

Figure 33. Field Repair Scheme, Skin-Core Plug Patch.

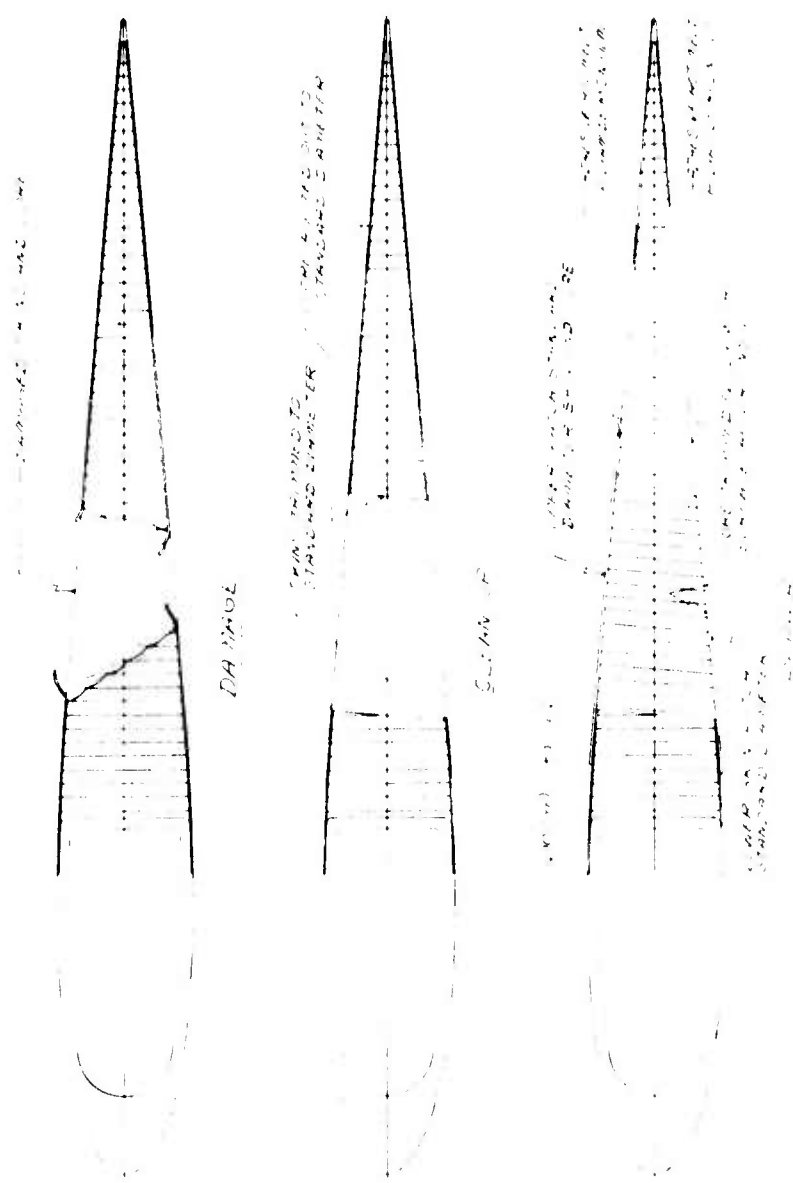
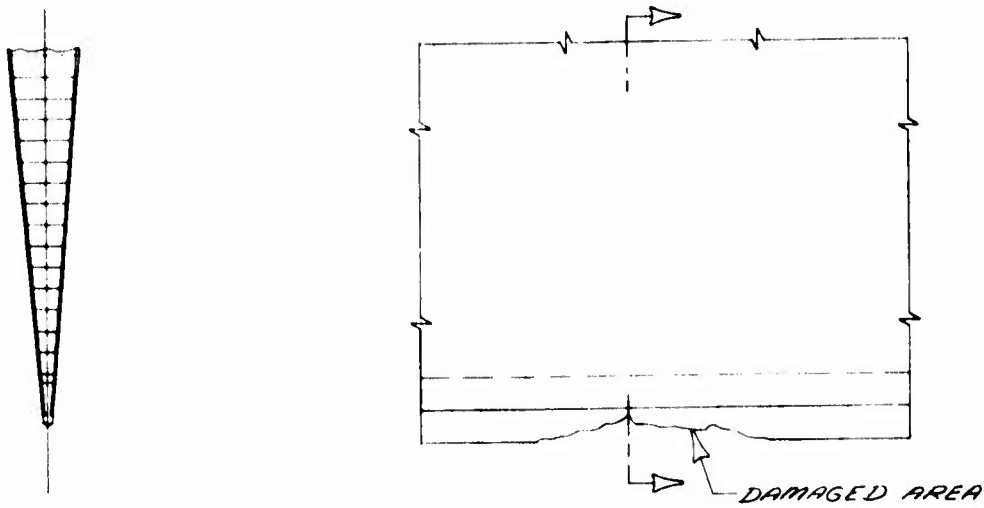
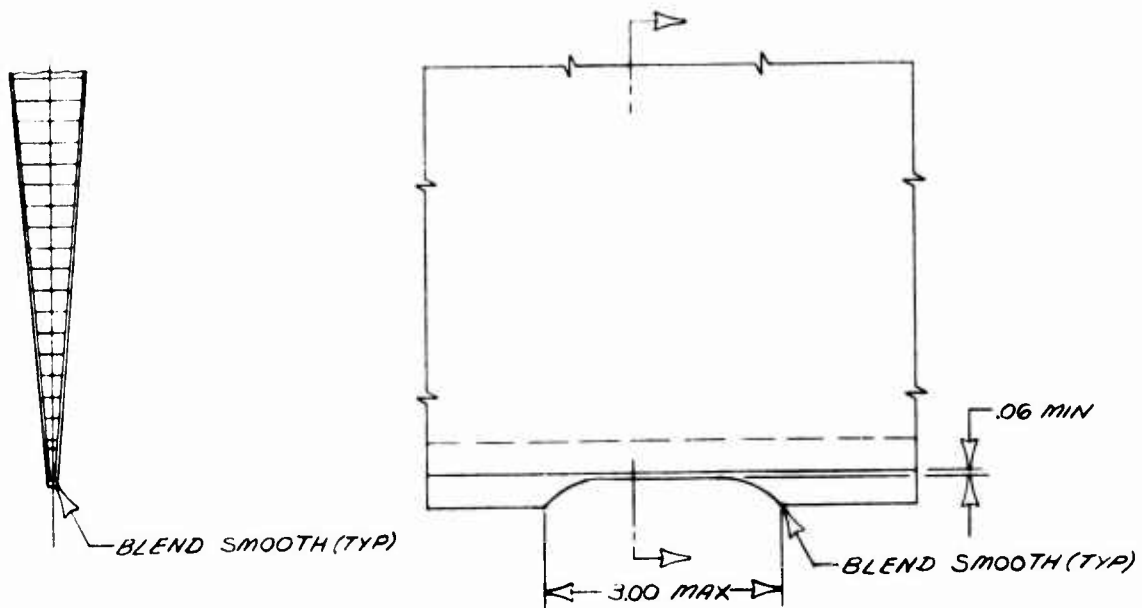

Figure 34. Field Repair Scheme, Skin-Core Through Patch.



DAMAGE



REPAIR

Figure 35. Field Repair Blend Limits, Trailing Edge.

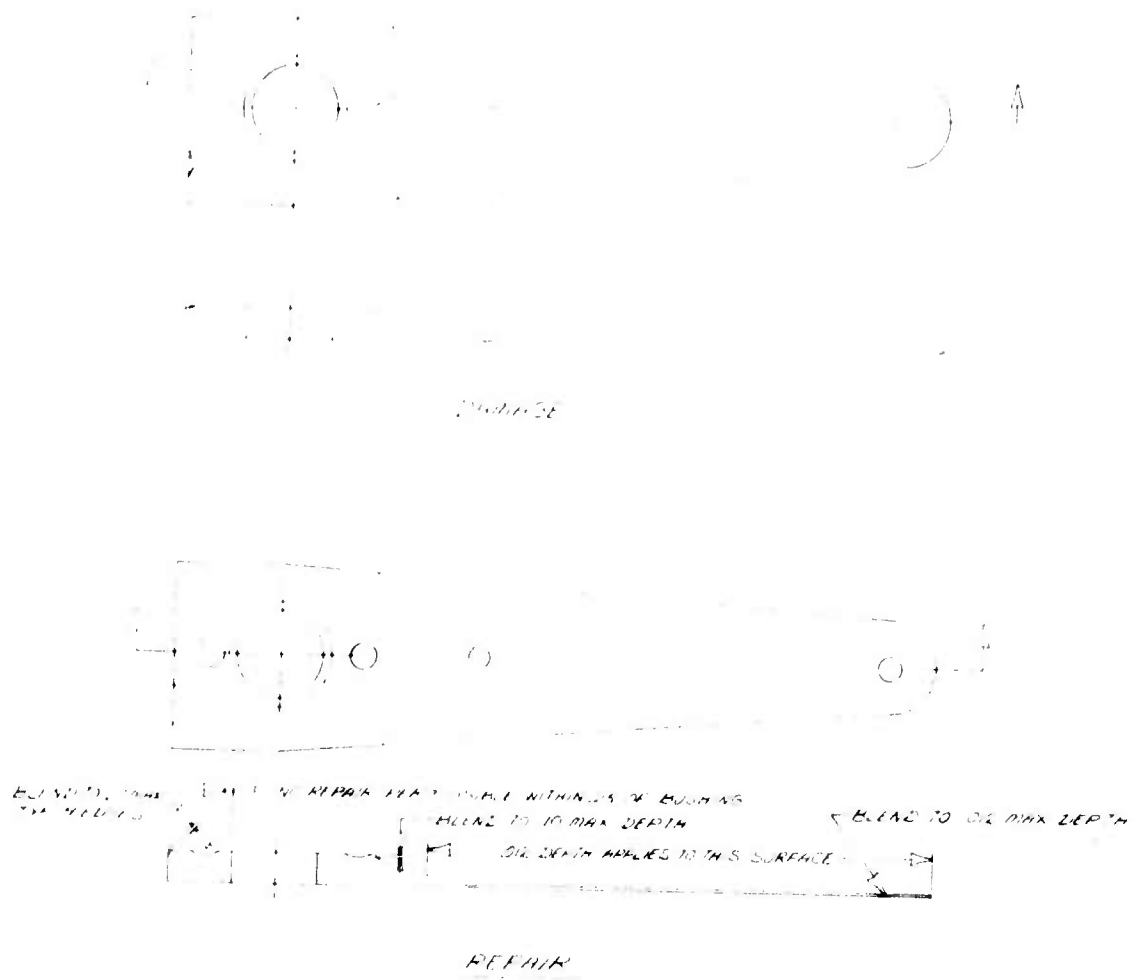

Figure 36. Field Repair Blend Limits, Root Reinforcement.

## SURVIVABILITY

The survivability of the current UH-1H main rotor blade and the field-repairable/expendable blade Concepts 1 and 3 have been investigated based on data from the application of the damage scenario to these blade designs during the maintainability and reliability analyses. The criteria used for evaluating survivability are the hazard classification and repairability of predicted damage events. The hazard classification, or criticality code, of damage events provides an estimate for survivability of the total system, that is, the aircraft and crew, while the repairability of damage events gives an estimate for survivability of the rotor blade alone as a unit of the total aircraft system. Table XVII lists the criticality code and repairability fractions for damage events reported previously in the failure modes and effects analysis for the current rotor blade and for Concepts 1 and 3 that are important in evaluating survivability. Data are presented for each type of damage defined in the damage scenario as well as for total external causes and the total damage scenario. From the safety viewpoint, the survivability of the current and new rotor blade designs can be compared using the fraction of total damage events classified in the critical category, as listed in Table XVII. Note that damage events assigned a critical hazard classification would require a mandatory abort to assure system survival, but damage events assigned to the less serious classifications of marginal or negligible would permit completion of the mission without injury to the crew or major damage to the aircraft.

Dents constitute the largest single type of damage, accounting for 54 percent of all external damage events and 42 percent of the total number of events within the damage scenario that fall on the presented areas of the three blade designs. Both field-repairable/expendable rotor blade Concepts 1 and 3 show a reduction in the fraction of critical damage events. This is due primarily to the larger presented area of the spars of these two designs experiencing an increased number of dent events compared to the current blade design, and fewer dents in the other blade components. Since the depths of dents specified in the damage scenario are reduced when they occur on the relatively hard metal spar area, most of these are classified as either marginal or negligible damage events. Concepts 1 and 3 also exhibit a marked increase in the fraction of repairable dent damage events, mainly because the fiberglass skins of these designs can be readily repaired in the field while the aluminum alloy skin of the current blade cannot be repaired in the field.

TABLE XVII. DAMAGE DATA FOR SURVIVABILITY ANALYSIS

Type of Damage	Damage Event Category	MRB Configuration		
		Current UH-1H	Concept 1	Concept 3
External				
Dent	Number of Events	1846	1846	1846
	Fraction Critical	.57	.45	.42
	" Marginal	.30	.52	.33
	" Negligible	.13	.03	.25
	" Repairable	.27	.60	.60
	" Scrap	.73	.40	.40
Puncture	Number of Events	677	677	677
	Fraction Critical	.27	.36	.45
	" Marginal	.64	.64	.55
	" Negligible	.09	-	-
	" Repairable	.64	.64	.55
	" Scrap	.36	.36	.45
Foreign Object Damage	Number of Events	554	554	554
	Fraction Critical	.28	.28	.22
	" Marginal	.39	.39	.33
	" Negligible	.33	.33	.45
	" Repairable	.55	1.00	1.00
	" Scrap	.45	-	-
Tear	Number of Events	370	370	370
	Fraction Critical	.25	.25	.16
	" Marginal	.25	.25	.34
	" Negligible	.50	.50	.50
	" Repairable	.50	1.00	1.00
	" Scrap	.50	-	-
Total of External Causes	Number of Events	3447	3447	3447
	Fraction Critical	.43	.38	.36
	" Marginal	.37	.49	.38
	" Negligible	.20	.13	.26
	" Repairable	.41	.72	.70
	" Scrap	.59	.28	.30

TABLE XVII - Continued

Type of Damage	Damage Event Category	MRB Configuration		
		Current UH-1H	Concept 1	Concept 3
Battle Damage	Number of Events	923	923	923
	Fraction Critical	.67	.67	.83
	" Marginal	.33	.33	.17
	" Negligible	-	-	-
	" Repairable	.07	.80	.60
	" Scrap	.93	.20	.40
Total Damage Scenario	Number of Events	4370	4370	4370
	Fraction Critical	.48	.44	.46
	" Marginal	.37	.46	.33
	" Negligible	.15	.10	.21
	" Repairable	.34	.73	.68
	" Scrap	.66	.27	.32

Punctures are defined here as holes penetrating through half the blade thickness. Damage of this type comprises 20 percent of external damage events and 15 percent of all damage scenario hits on the blades. Concepts 1 and 3 experience more spar punctures than the current blade design because of their larger spar presented areas. Since punctures of the spar are considered to be critical, nonrepairable events, both of the new designs show an increase in the fraction of critical damage events. Concept 3, which has the largest spar presented area, exhibits the largest fraction of critical events. The repairability of the current blade design and that of Concept 1 are comparable, but that of Concept 3 is considerably less. The relatively large number of spar puncture events experienced by Concept 3 causes a significant reduction in the fraction of repairable puncture events.

Foreign-object damage and tears are the remaining types of external damage causes. These make up approximately 16 percent and 11 percent respectively of all external damage events and 13 percent and 8 percent respectively of all damage scenario events incident on the blade areas. The fraction of critical events for these types of damage is comparable for the current blade and Concept 1, while Concept 3 shows a slightly smaller critical fraction. Virtually all tear and foreign-object damage experienced by Concepts 1 and 3 is repairable, which represents a substantial improvement over the repairability of the current blade.

The data of Table XVII for the total of external damage causes indicate that Concepts 1 and 3 differ only slightly in the fraction of critical damage events, both showing significant improvement over the current blade design in this respect. The new designs also exhibit a substantial increase in repairability compared to the current blade. Concept 1 has a slight advantage over Concept 3 in repairability since Concept 3, due to its larger spar presented area, experiences more nonrepairable spar puncture damage events. The total of external causes includes all events of the damage scenario falling on the blade presented area except those events defined as battle damage. Thus these data are considered to be representative of the comparative survivability of the three rotor blade designs in a noncombat environment. For this case, Concepts 1 and 3 are both judged to be superior to the current blade design in survivability characteristics. Because the differences indicated between Concepts 1 and 3 in the fraction of critical events and in repairability are relatively minor, these two designs are judged to be of approximately equal survivability in noncombat situations.

Battle damage, defined as projectile penetration through full blade thickness, accounts for 21 percent of all damage scenario events incident on the blade presented area. For this type of damage, Concept 3 shows a substantially greater fraction of critical events than either Concept 1 or the current blade design. Once again, this is due to the significantly larger presented area of the formed sheet-metal spar experiencing a greater number of ballistic damage strikes, all of which are considered to be critical events. Concepts 1 and 3 both offer substantially greater repairability for battle damage than the current blade design. Concept 1, however, is still considerably more repairable than Concept 3 because the larger number of spar hits taken by Concept 3 are all nonrepairable.

The total damage scenario data presented in Table XVII shows that Concept 1 has the smallest fraction of critical events, although the spread among the critical fractions for the three blade designs is not large. In addition, Concept 1 still holds an edge over Concept 3 in repairability, but both of these new designs are much more repairable than the current blade design.

In summary, total system survivability from the safety viewpoint, as measured by the fraction of critical events for the total damage scenario, gives a slight advantage to Concept 1 over Concept 3 and the current blade design. However, differences noted in critical damage fractions for the three blade designs are negligible, for all practical purposes, in light of the qualitative judgments involved in evaluating the hazard classifications of damage events incident on the various rotor blade components. From the rotor blade survivability viewpoint, as measured by the fraction of repairable damage events, both Concepts 1 and 3 are far superior to the current blade, with Concept 1 having an edge over Concept 3 because of the fewer number of nonrepairable events experienced by the Concept 1 spar. In both respects, the survivability of Concept 3 suffers because of the large presented area of the formed sheet-metal spar exposed to the damage scenario.

## LIFE-CYCLE COSTS

Typical outputs from the life-cycle cost machine program are given in Appendix VII. Because of the rapid turnaround time from the conversational computer, it was possible to vary many of the parameters and establish trends.

Table XVIII presents a comparison of the helicopter life-cycle blade-related costs for the current UH-1H main rotor blade and for each of the design concepts evaluated. These comparisons are made at mean-time-between-failures of 600 hours and 1000 hours applied to the current blade as currently operated. For the design concepts, these MTBF's are somewhat higher, dependent on the "survivability factor", which is simply the ratio between the number of failures accumulated for the current blade and the number to which these reduce when the causes are applied to each field repairable/expandable blade concept. A better term would be "reliability factor".

Figure 37 illustrates the effect of initial procurement cost on life-cycle costs, Figure 38 that of vulnerability and reliability, expressed as time between failures, Figure 39 that of repairability, and Figure 40, that of fatigue life on life-cycle costs. Figures 41 and 42 repeat Figures 38 and 39, respectively, for a noncombat operational environment.

It was initially intended that a value of 914 hours between failures, from Table E-I of Reference 1, would be used as the basis for determining rates of failure and life-cycle costs, as planned in Appendix II. However, subsequent information has indicated that this may be an unconservative number, so the curves of Figures 38 and 42 are plotted for a range of failure rates. The other curves use 600 hours as the base MTBF.

It should also be noted, from Appendix VII, that incorporation of depot repair in the maintenance cycle of the current blade saves an almost-negligible \$700 (in \$45,000) in the cost of each helicopter life cycle.

TABLE XVIII. LIFE-CYCLE COST SUMMARY

Mean Time Between Failures (Current Blade Operations as Base) Concept	600 Hours	1000 Hours
	Life-Cycle Blade Costs \$K	
A. With Combat		
Current UH-1D/H Blade	60.36	44.02
1	33.86	27.16
2	34.67	27.81
3	48.37	38.98
4	48.69	39.23
5	46.15	37.18
6	46.48	37.45
7	34.15	27.39
8	34.95	28.04
9	34.11	27.37
10	34.92	28.02
11	38.92	31.40
12	39.79	32.03
B. Without Combat		
Current UH-1D/H Blade	54.32	40.86
1	31.15	25.47
2	31.89	26.08
3	44.48	36.08
4	45.03	35.80
5	42.43	36.22
6	42.89	34.57
7	31.41	26.68
8	32.15	26.29
9	31.39	25.66
10	32.13	26.27
11	35.89	29.45
12	36.63	30.06

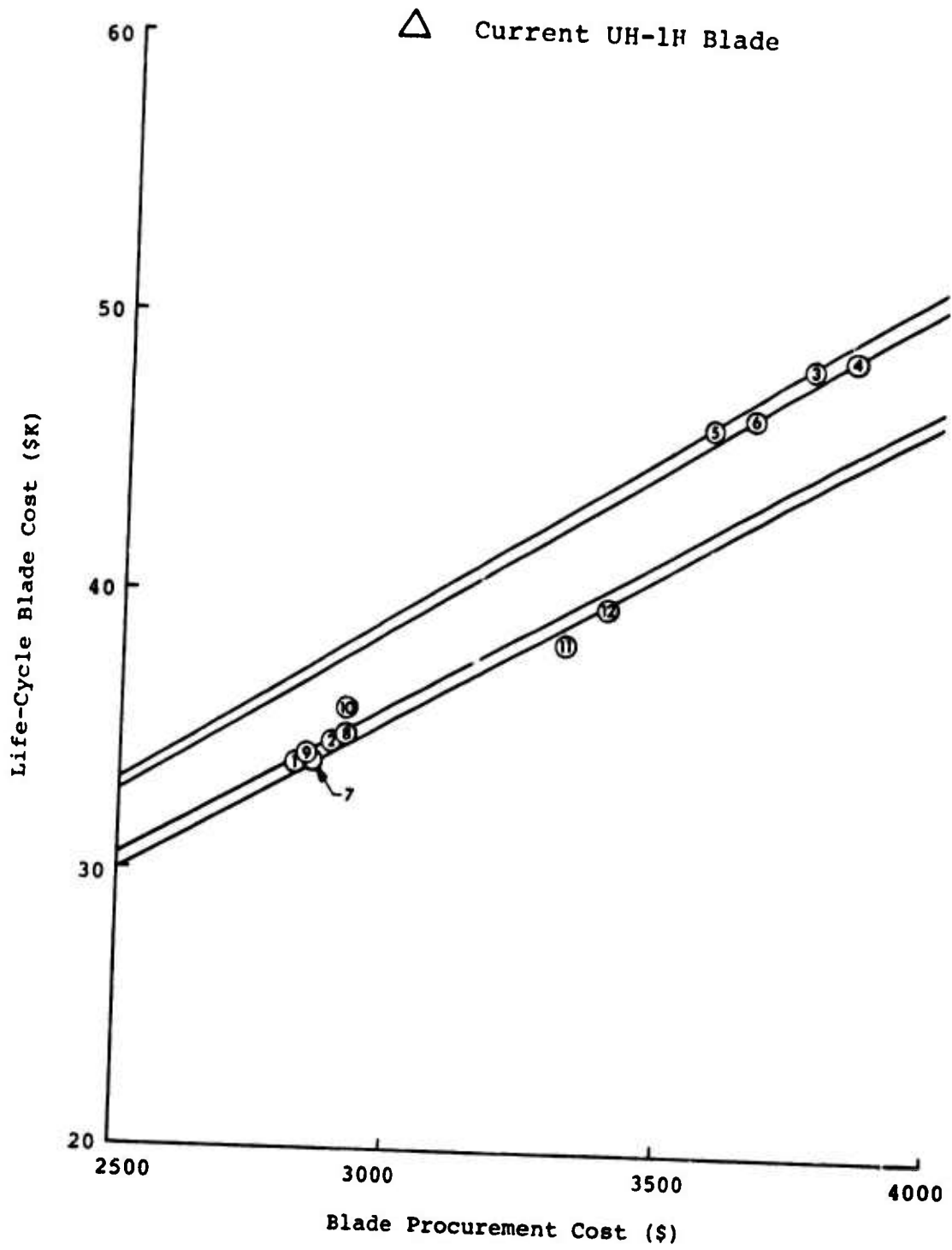

Figure 37. Life-Cycle Costs vs. Initial Procurement Costs.

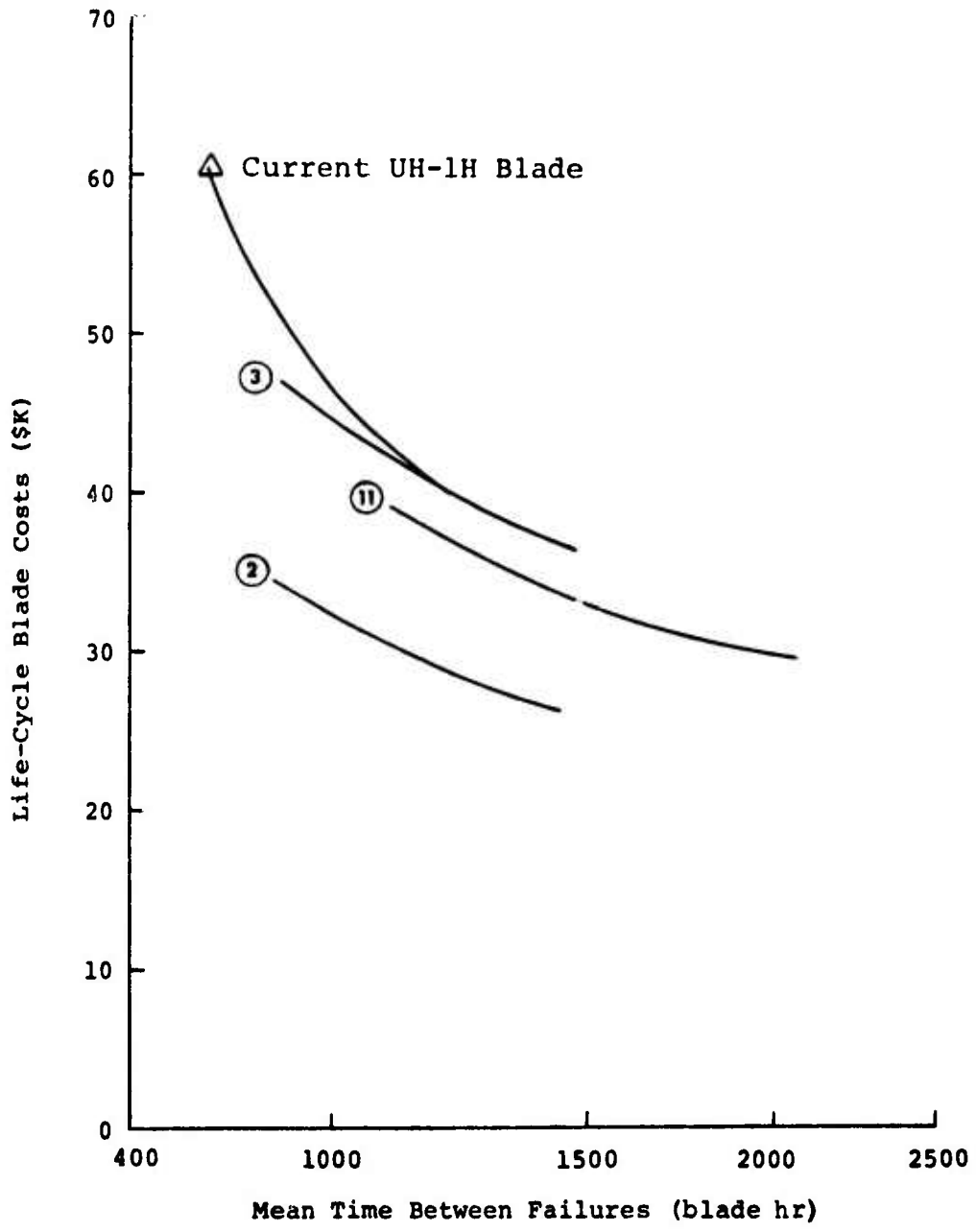

Figure 38. Life-Cycle Costs vs. Mean Time Between Failures.

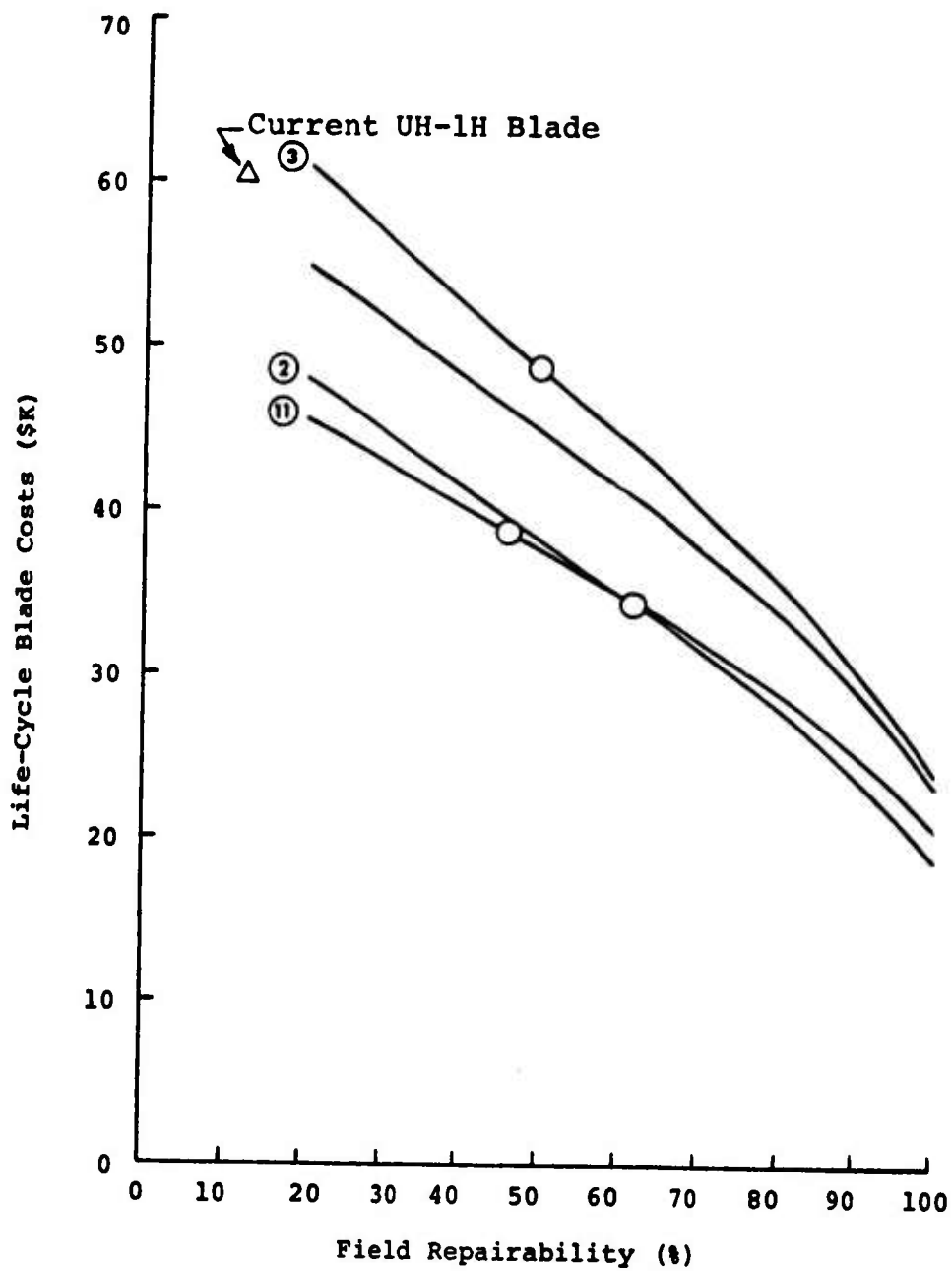

Figure 39. Life-Cycle Costs vs. Field Repairability.

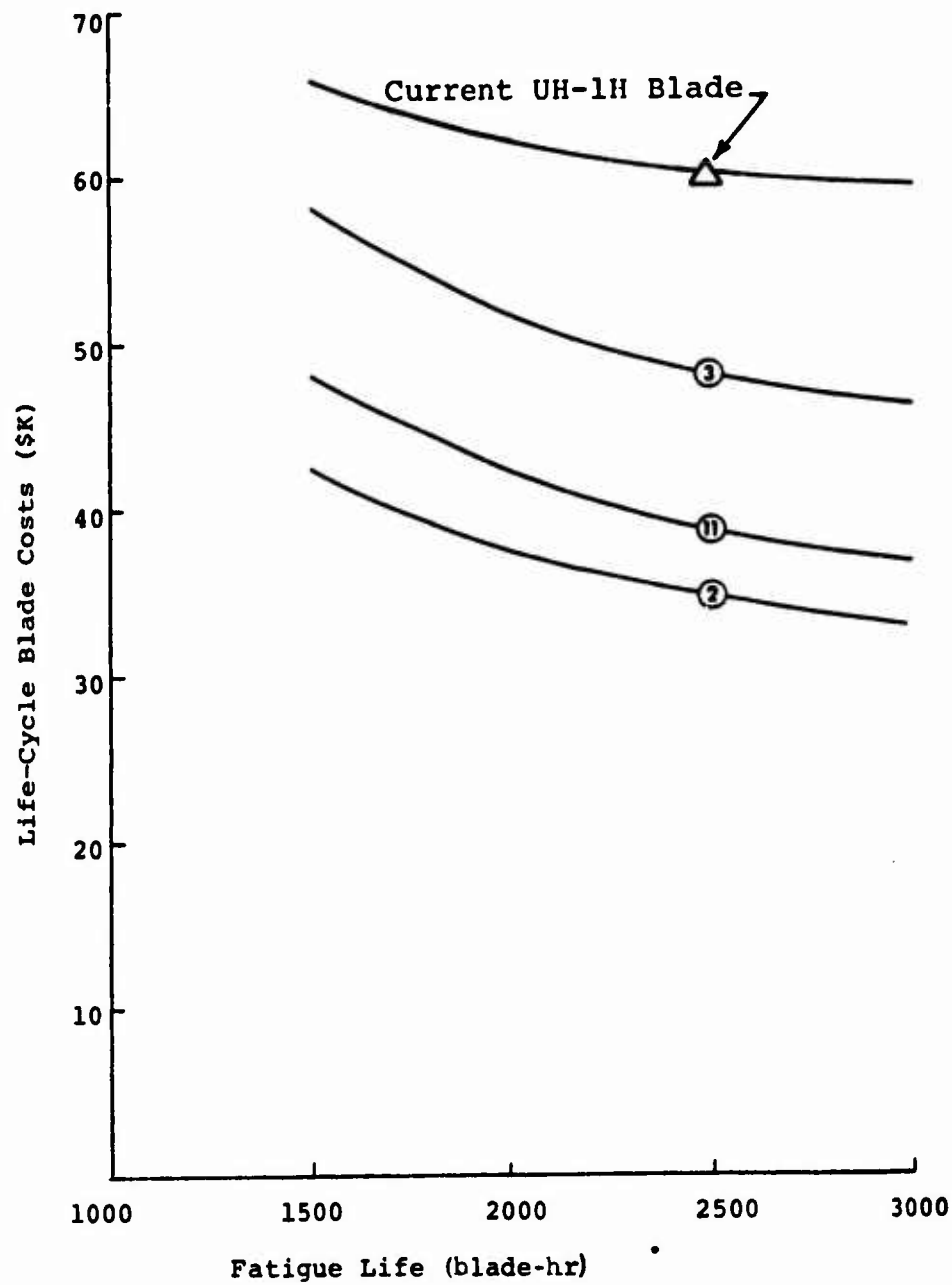

Figure 40. Life-Cycle Costs vs. Fatigue-Limited Service Life.

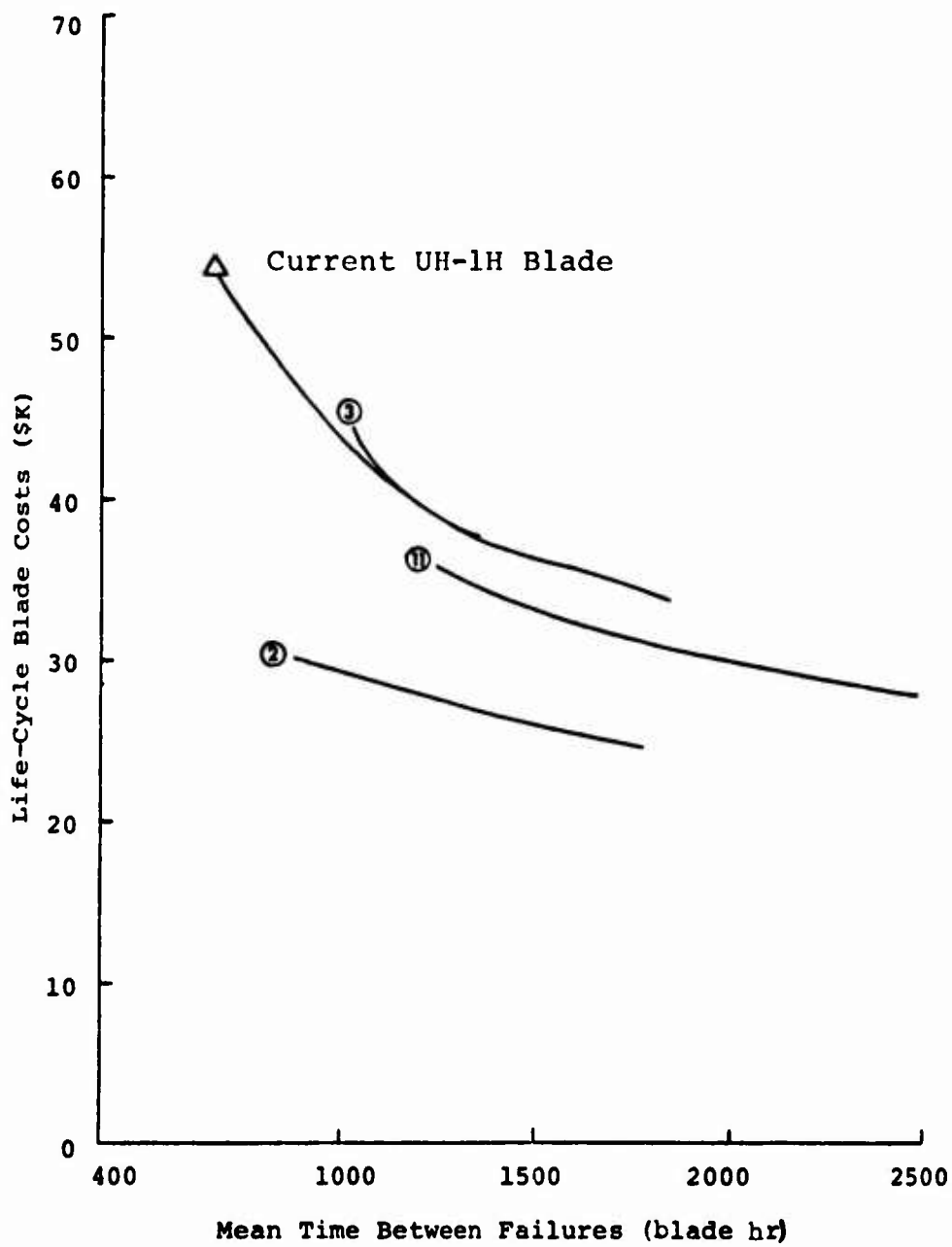

Figure 41. Life-Cycle Costs vs. Mean Time Between Failures, Noncombat Environment.

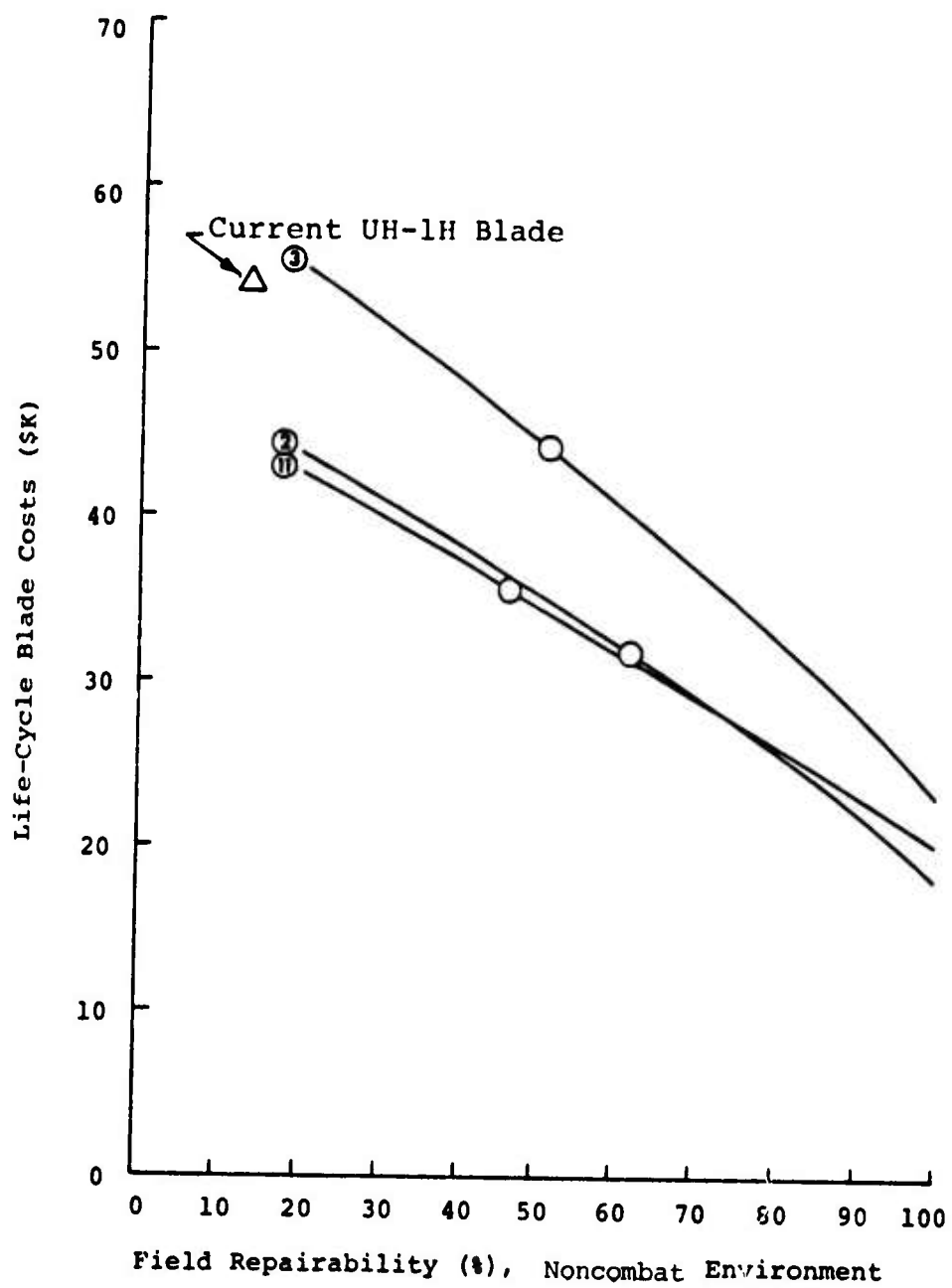

Figure 42. Life-Cycle Costs vs. Field Repairability, Noncombat Environment.

## CONCLUSIONS

The application of maintainability and reliability criteria during the preliminary design phase has resulted in a significant theoretical reduction in potential blade-related life-cycle costs. These criteria were applied to all the field repairable/expendable main rotor blade concepts examined, and all show a reduction in cost below that of the current blade. Figure 37 shows that for the FREB concepts, life-cycle costs are approximately proportional to initial procurement cost, while the current blade, whose initial price (at \$3000) is toward the low end of the range, has the highest operating costs of all.

During this phase of the program, it became evident that the maintainability analysts, who normally provide a service function after aircraft systems are in operation, are not accustomed to influencing the design process from its initiation. One recommendation to be made here is that means should be found for using their valuable accumulation of experience from the start of design, of any system, as a matter of habit. Reduced maintenance costs would then result from foresight rather than hindsight. In Phase II of this program, the maintenance analysts will have drawing sign-off privileges.

## POTENTIAL FOR ACHIEVING PROGRAM GOALS

Any of the design concepts examined shows a significant reduction in life-cycle costs below those attributable to the current blade. With the exception of the acoustic signature, none of the technical requirements are jeopardized by any of the concepts, although special treatment of the aft surface may be required to avoid an increase in radar reflectivity. The technical, operational, and cost goals can be met, as outlined below.

- **Weight and Balance:** Each of the concepts studied can meet the weight and balance limits, with the appropriate design of tip weights.
- **Dynamic Characteristics:** The computed dynamic behavior of all concepts is similar to that of the current UH-1H.
- **Stress Levels:** The concepts with aluminum spars show a slight reduction in margin of safety below that of the current blade. This may result in a slight reduction in fatigue-limited allowable service life. Figure 40 shows that a reduction in fatigue life has a relatively small

effect on life-cycle costs, which remain substantially reduced from those of the current blade.

- **Aerodynamic Performance:** The aerodynamic performance is unchanged for six of the concepts, but those with the simplified airfoil may be penalized in forward flight by the decrease in drag-divergence Mach number.
- **Radar Cross Section:** The RCS study shows that the increased nose radius of the simplified section may give a minor increase in radar return from the leading edge and that the return in the trailing-edge aspect will be significantly increased. The latter effect can be eliminated by the use of reflecting paint on the reinforced-plastic aft skins.
- **Acoustic Signature:** The noise generated by six of the concepts will be the same as that of the current blade, but those six having the simplified airfoil section cannot meet this criterion.
- **Maintenance Time:** The 95<sup>th</sup> percentile maximum elapsed time for active corrective maintenance is predicted to be below or very slightly above the 3.0-hour goal for each of the concepts.
- **Survivability:** The survivability of each of the concepts is expected to be slightly improved over that of the current blade.
- **Life-Cycle Costs:** Each of the concepts examined shows a theoretical prediction of helicopter life-cycle blade-related costs considerably below those associated with the current blade, in both combat and noncombat environments. The lowest overall costs are associated with the lowest initial procurement price.

#### CONCEPT SELECTION

All of the concepts using the modified ("simplified") airfoil section are eliminated from contention by their degradation in acoustic signature, and possibly in forward-flight performance.

Of the remaining six concepts, that with the lowest predicted life-cycle costs is Concept 2, which therefore is chosen as the concept with which the remainder of the program will continue. Although not a consideration in this selection, this concept is also the least expensive to manufacture in the quantities required for development.

### LITERATURE CITED

1. Carr, P. V., and Hensley, O. L., UH-1 AND AH-1 HELICOPTER MAIN ROTOR BLADE FAILURE AND SCRAP RATE DATA ANALYSIS, Bell Helicopter Company; USAAVLABS Technical Report 71-9, Eustis Directorate, U. S. Army Air Mobility Research and Development Laboratory, Fort Eustis, Virginia, January 1971, AD 881132L.
2. Maloney, P. F., and Akeley, C. R., DESIGN STUDY OF REPAIRABLE MAIN ROTOR BLADES, Kaman Aerospace Corporation; USAAMRDL Technical Report 72-12, Eustis Directorate, U. S. Army Air Mobility Research and Development Laboratory, Fort Eustis, Virginia, July 1972, AD 749283.
3. Frengley, M. C., Maloney, P. F., and Akeley, C. R., DESIGN STUDY OF EXPENDABLE MAIN ROTOR BLADES, Kaman Aerospace Corporation; USAAMRDL Technical Report 72-48, Eustis Directorate, U. S. Army Air Mobility Research and Development Laboratory, Fort Eustis, Virginia, October 1972, AD 758464.
4. Tarczynski, T., SECTIONALIZED MAIN ROTOR BLADE ADVANCED DESIGN STUDY, The Boeing Company, Vertol Division; USAAMRDL Technical Report 72-8, Eustis Directorate, U. S. Army Air Mobility Research and Development Laboratory, Fort Eustis, Virginia, August 1972, AD 750633.
5. Longobardi, J. A., EXPENDABLE MAIN ROTOR BLADE STUDY, Sikorsky Aircraft Division of United Aircraft Corporation; USAAMRDL Technical Report 72-47, Eustis Directorate, U.S. Army Air Mobility Research and Development Laboratory, Fort Eustis, Virginia, April 1973, AD 762198.
6. Abildskov, D., Ashton, L., and Wall, D., UH-1D FILAMENT-WOUND TUBULAR REINFORCED ROTOR BLADE, Fiber Science Inc.; USAAMRDL Technical Report 73-61, Eustis Directorate, U. S. Army Air Mobility Research and Development Laboratory, Fort Eustis, Virginia, October 1973.
7. Hagen, J. H., THE DEVELOPMENT OF A COMPOSITE MAIN ROTOR BLADE FOR THE SUD-AVIATION SA-330 HELICOPTER, Parsons Corporation; SAE Preprint 680693, Aeronautic and Space Engineering and Manufacturing Meeting, Society of Automotive Engineers, Inc., Two Pennsylvania Plaza, New York, New York, October 1968.

8. Lawson, M. V., and Ollerhead, J. B., STUDIES OF HELICOPTER ROTOR NOISE, Wyle Laboratories; USAAVLABS Technical Report 68-60, U. S. Army Aviation Materiel Laboratories, Fort Eustis, Virginia, January 1969, AD 684394.
9. Ollerhead, J. B., HELICOPTER AURAL DETECTABILITY, Wyle Laboratories; USAAMRDL Technical Report 71-33, Eustis Directorate, U. S. Army Air Mobility Research and Development Laboratory, Fort Eustis, Virginia, July 1971, AD 730788.
10. Shivers, J. P., and Carpenter, P. J., EFFECTS OF COMPRESSIBILITY ON ROTOR HOVERING PERFORMANCE AND SYNTHESIZED BLADE-SECTION CHARACTERISTICS DERIVED FROM MEASURED ROTOR PERFORMANCE OF BLADES HAVING NACA 0015 AIRFOIL TIP SECTIONS; NACA Technical Note 4356, Langley Aeronautics, Langley Field, Virginia, September 1958.
11. Clark, Manley W., Krauss, William K., and Ciccootti, James M., IDENTIFICATION AND ANALYSIS OF ARMY HELICOPTER RELIABILITY AND MAINTAINABILITY PROBLEMS AND DEFICIENCIES, American Power Jet Company; USAAMRDL Technical Report 72-11, Volume I-INTRODUCTION, ANALYSIS, AND SUMMARY, and Volume II-UTILITY, ATTACK, AND TRAINING HELICOPTERS, Eustis Directorate, U. S. Army Mobility Research and Development Laboratory, Fort Eustis, Virginia, April 1972, AD 901456L and AD 901457L.
12. ENGINEERING DESIGN HANDBOOK, MAINTAINABILITY GUIDE FOR DESIGN, Army Materiel Command Pamphlet AMCP 706-134.
13. MAINTAINABILITY ENGINEERING, Department of the Army Pamphlet DAPAM 705-1, June 1966.
14. Blanchard, Benjamin S., and Lowery, Edward E., MAINTAINABILITY PRINCIPLES AND PRACTICES, New York, McGraw Hill, 1969.
15. Wierenga, B. B., Blake, D. O., Hanson, R. E., and Cook, T. N., ANALYSIS OF ARMY HELICOPTER INSPECTION REQUIREMENTS, RCA/Government and Commercial Systems; USAAMRDL Technical Report 72-35, Eustis Directorate, U. S. Army Air Mobility Research and Development Laboratory, Fort Eustis, Virginia, September 1972.
16. Bacho, J. A., McCarley, J. A., Walker, N. S., Watkins, T. C., and Watson, R., Jr., MAINTENANCE DATA TABULATIONS, CH-47A, Northrop Corporation, Report No. WSDS 72-5, July 1972.

17. MIL-STD-471 MAINTAINABILITY DEMONSTRATION, Department of Defense, Washington, D. C., 20025, February 1966.
18. MIL-HDBK-472 MAINTAINABILITY PREDICTION, Department of Defense, Washington, D. C., 20025, May 1966.
19. STRENGTH AND STIFFNESS THROUGH FIBER ORIENTATION, Minnesota Mining and Manufacturing Company; SP-RSF Design Guide.

## APPENDIX I

### DESIGN SPECIFICATION, HELICOPTER MAIN ROTOR BLADE

#### 1.0 GENERAL

This specification provides design requirements for a field-repairable/expendable main rotor blade for a medium utility helicopter.

#### 1.1 System Compatibility

The rotor blade shall be aerodynamically, dynamically, and structurally compatible with the airframe of the UH-1H helicopter, and with the missions for which that helicopter is used.

- 1.1.1 The vibration level attributable to the main rotor shall not be increased from that of the UH-1H helicopter as equipped at the date of this specification.
- 1.1.2 The loads applied to the rotor hub by the field-repairable/expendable blades shall not be so high as to reduce the fatigue life of the hub structure nor the service life of bearings or other components. The static strength of the hub shall not be exceeded.
- 1.1.3 Clearance from the fuselage to the field-repairable/expendable blade shall not be significantly less than that to the current blade, i.e., the blade installed on the main rotor of the UH-1H helicopter at the date of this specification.
- 1.1.4 The blade shall extend from the root cutoff at rotor station 24.5 to the tip at rotor station 288.0 (24.5 and 288.0 inches, respectively, from the center of rotation). The tip cap and tracking nib may extend beyond rotor station 288.0 by no more than 1.63 inches, but major structural components shall not.
- 1.1.5 The chord length shall be 21.0 inches, constant from root to tip.
- 1.1.6 The maximum thickness of the clean airfoil section shall be 2.52 inches.
- 1.1.7 The blade shall be twisted  $10.9^{\circ}$  from the center of rotation to the tip (27.27' per foot).
- 1.1.8 The root attachments shall be a 2.5-inch bolt at rotor station 28.0 and chord station 3.750 (measured from the leading edge) and a 1.125-inch bolt at rotor station 26.0 and chord station 19.5. The thickness through the main retention shall be 4.5 inches, and 1.9 inches through the drag strut fitting.

## 1.2 Interchangeability

It shall be possible to remove any one blade of the field-repairable/expendable series and replace it by another of the series and achieve balance, track, and acceptable flying qualities without adjustment of weights. The only acceptable adjustments will be to the pitch link and trim tab.

## 1.3 Expendability

To meet the requirement that the cost impact of abandoning the blade be minimized, the blade price in quantity production shall not exceed \$4000 per unit.

## 1.4 Reliability

The occurrence of damage due to inherent causes shall be minimized.

1.4.1 If any materials are used which are not known to be corrosion resistant, such materials will be protected against corrosion per MIL-F-7179D, Type 1.

1.4.2 The leading edge shall be protected against erosion by rainfall as defined for Category 2 of AR 70-38. The blade shall be assumed to operate in the 12-hour rainfall defined in 2-8c of AR 70-38 for 10% of its allowable service life. The leading edge shall not be eroded sufficiently to cause significant degradation in aerodynamic performance or structural integrity.

1.4.3 The leading edge shall be protected against abrasion by sand and dust as defined for Category 4 of AR 70-38. The blade shall be assumed to hover in ground effect for 3% of its allowable service life, in sand and dust particles as defined in 2-10f and 2-10g of AR 70-38, except that, for unit ground area, sand particles shall be distributed up to the rotor height, with half the particles below 1/10 rotor height, and dust particles will be distributed to the rotor height.

1.4.4 The number of adhesive bond lines subject to delamination shall be minimized. The basic blade (excluding root and tip reinforcement and hardware) shall be made up of not more than eight components.

## 1.5 Vulnerability

The severity of damage due to external causes shall be minimized.

1.5.1 Thin sheet components shall be of such thicknesses and materials as to resist damage due to impact equivalent to a 1-pound steel ball dropped from a height of 2 feet.

- 1.5.2 Thin sheet components shall be of materials such that puncture damage will not immediately propagate into a tear.
- 1.5.3 Internal support structure shall be of resilient material such that negligible surface damage does not cause internal damage.
- 1.5.4 Impact with immovable objects, such as a tree strike, having energy insufficient to cause significant damage to structural components shall not cause delamination of adhesive bond joints.
- 1.5.5 No component shall be of any material that will shatter or disintegrate due to nonexplosive ballistic damage, up to and including penetration by a 23mm API round.

#### 1.6 Survivability

The rotor blade shall be designed so that initially marginal damage shall not become catastrophic before the aircraft can return to base.

- 1.6.1 Where possible, primary structure shall be designed with alternate load paths, each capable of carrying the centrifugal force and bending moments associated with undamaged blades in maneuvers up to 1.2 g at cruise speed, for a minimum of ten (10) hours.
- 1.6.2 Materials shall be used throughout whose crack propagation rates are slow enough that initially marginal damage shall not become catastrophic for a minimum of ten (10) hours, under the centrifugal force and bending moments associated with undamaged blades in maneuvers up to 1.2 g at cruise speed.
- 1.6.3 On impact with immovable objects, damage shall be confined to deformation, or bending, and no component shall fracture or separate.
- 1.6.4 Nonexplosive ballistic damage, up to and including penetration by a 23mm API round, shall not be catastrophic; that is, material dislodged or detached from the blade shall be of insufficient mass to cause an unmanageable increase in vibration level in the aircraft.

#### 1.7 Maintainability

All allowable repairs shall be safely and reliably accomplishable at the using unit level. Routine maintenance shall be performed at the using unit level.

- 1.7.1 Repairs requiring replacement of primary structural material shall not be permissible, and damage to such material shall be cause for scrap. Delamination of adhesive bonds involving primary structure shall be cause for scrap.

- 1.7.2 The skill level of the maintenance personnel shall be that of a UH-1 helicopter repairman, MOS 67N20.
- 1.7.3 No more than two men shall be required to accomplish any individual maintenance action, exclusive of blade removal and replacement.
- 1.7.4 The time goal to accomplish any individual repair shall be no greater than 3.0 hours, including any required adhesive cure time and correction of balance and track.
- 1.7.5 Not more than 5% of the repairable damage occurrences shall require removal of the blade from the aircraft.
- 1.7.6 The maximum elapsed corrective maintenance time (at the 95th percentile confidence level) to return the aircraft to operational readiness status shall be 3.0 hours, for the entire population of corrective maintenance tasks.
- 1.7.7 Blade balance shall be corrected using easily accessible adjustable weights installed at the tip. The amount of weight change shall be simply defined and related to each individual repair.
- 1.7.8 Dents, nicks, and scratches shall be repaired by blending and/or filling, unless structural or contour degradation is not significant.
- 1.7.9 Repairs to punctures, tears, and cracks shall be designed to minimize stress concentrations, and shall be permissible only in those areas and materials where stress concentrations will not cause subsequent secondary failures.
- 1.7.10 Punctures, tears, and cracks shall be cleaned up and repaired using standard, prepackaged repair kits. The repair kits shall contain patch materials (protected against contamination), cleaning materials, and adhesives in measured quantities appropriate to the patch size.
- 1.7.11 Heat and pressure sources will preferably be self-contained in the repair kits, but use of aircraft on-board auxiliary power will be permissible.
- 1.7.12 Support equipment needed to effect repairs shall be minimized and shall be suitable for deployment at company level.

#### 1.8 Radar Cross Section

The radar return, at all frequencies appropriate to possible threat radars, shall not exceed that of an all-metal blade of 288.0 inches radius, 21.0 inches chord, and NACA 0012 airfoil section.

1.8.1 The total of the appropriately weighted returns from both leading- and trailing-edge aspects shall not exceed that of the target described above.

1.8.2 The peak return at any aspect shall not exceed the peak return from the target described above.

### 1.9 Acoustic Signature

The acoustic detectability of the field-repairable/expendable blade shall not exceed that of a blade of 288.0 inches radius, 21.0 inches chord, and NACA 0012 airfoil section, with square tips.

### 2.0 WEIGHT AND BALANCE

The weight and balance characteristics shall not represent a degradation from the current blade, in terms of rotor system and control system loads, but the field-repairable/expendable blades need not be directly interchangeable with the current blade.

#### 2.1 Total Weight

The total weight, including balance adjustment, of the field-repairable/expendable rotor blade, based on nominal component dimensions and material densities, shall not exceed 203.5 pounds.

#### 2.2 Mass Moment About Center of Rotation

The nominal first moment of mass about the center of rotation shall not exceed 29,000 in.-lb.

#### 2.3 Chordwise Center of Gravity

The nominal center of gravity shall not be farther than 5.78 inches (27.5% chord) from the leading edge.

#### 2.4 Dynamic Mass Axis

The dynamic mass axis, or span-weighted chordwise center of gravity, as obtained by dividing the nominal product of inertia about the leading edge and center of rotation by the nominal first moment of mass about the center of rotation, shall not be farther than 5.15 inches (24.5% chord) from the leading edge.

#### 2.5 Kinetic Energy

In order to provide sufficient response time in the event of an engine failure, the second moment of mass about the center of rotation shall not be less than 1000 slug-ft<sup>2</sup> for one nominal blade.

### 3.0 STRUCTURE

The strength and stiffness of the blade structure shall not allow a significant decrease in fatigue life, nor a significant degradation in dynamic characteristics, from those of the current blade.

#### 3.1 Static Strength

The bending strength of the blade shall be capable of supporting the blade as a cantilever under an ultimate acceleration of at least 4.0 g.

#### 3.2 Fatigue Strength

The fatigue life under the maneuver spectrum defined for the UH-1H utility mission shall not be less than 2000 hours.

#### 3.3 Flatwise Stiffness

The flatwise bending stiffness shall be such that the downward deflection at the blade tip, under 1.0 g acceleration, with the root fixed in a horizontal attitude, shall not exceed 8.0 inches.

#### 3.4 Edgewise Stiffness

In order to provide sufficient margin beyond ground self-excited mechanical instability limits, the edgewise bending stiffness at rotor station 81.0 shall not be less than 2.2 billion lb-in<sup>2</sup>.

#### 3.5 Torsional Stiffness

In order to ensure that torsional and coupled modes of blade vibration have no greater significance than those of the current blade, the torsional stiffness of the field-repairable/expendable blade shall average, over the span, no less than 29.0 million lb-in<sup>2</sup> and shall not be less than 31.0 million lb-in<sup>2</sup> at rotor station 81.0.

### 4.0 SPARS

4.1 Spars composed of more than one component shall have structural material apportioned between the components so that residual strength after complete failure of any one component will allow operation for a minimum of ten (10) hours under the loads and moments defined in 1.6.1.

- 4.2 Thicknesses and types of adhesives between spar components shall be selected so as to delay crack propagation across any bond line for a minimum of ten (10) hours of operation under the loads and moments defined in 1.6.1 and 1.6.2.
- 4.3 Spars composed of one component shall be made from material whose crack propagation rate shall allow normal operation for a minimum of ten (10) hours from failure initiation to critical failure, under the loads and moments defined in 1.6.2.
- 4.4 Both internal and external surfaces of the spars shall be resistant to or protected from corrosion so as to remain serviceable for a minimum of five (5) years.
- 4.5 Spar repairs shall be limited to blending and/or filling of dents, scratches, and nicks.
- 5.0 SKINS
- 5.1 Skin materials shall be corrosion resistant.
- 5.2 Skin thicknesses and materials shall be selected so that impact as defined in 1.5.1 shall cause negligible or no damage.
- 5.3 The structural design of the blade shall be such that a complete chordwise skin failure aft of the spar shall not be catastrophic.
- 5.4 The crack propagation rate of the skin material shall be such as to allow normal operation for a minimum of ten (10) hours from failure initiation to a complete chordwise skin failure, aft of the spar, under loads and moments as defined in 1.6.2.
- 5.5 Thicknesses and types of adhesives between skins and adjacent primary structure shall be selected so as to delay crack propagation from skin to adjacent structure for a minimum of ten (10) hours of normal operation under loads and moments as defined in 1.6.1 and 1.6.2.
- 5.6 To minimize stress concentrations in adjacent structure due to a failure in the skin, the modulus of elasticity of the skin material shall not be greater than that of any adjacent primary structural material.
- 5.7 Nicks and scratches in nonmetallic skins less than one-half the skin thickness shall be considered negligible, but they may be filled to improve appearance.
- 5.8 Any damage to nonmetallic skins exceeding one-half the skin thickness shall be removed and repaired using a suitable patch kit.

- 5.9 Skin repairs and patch kits shall be so designed that the fatigue life of a patched skin shall be no less than the allowable service life of the undamaged blade.
- 5.10 Nicks and scratches in metal skins shall be polished out to a depth not more than one-half the skin thickness, or .015 inch, whichever is least.
- 5.11 Any damage to metal skins exceeding one-half the skin thickness or .015 inch shall be cause for scrapping the blade.
- 5.12 Dents less than .030 inch deep and having unbroken surfaces, in either metal or nonmetal skins, shall be considered negligible.

#### 6.0 SKIN INTERNAL SUPPORT STRUCTURE

- 6.1 Internal structure under and between the skins shall be of corrosion-resistant material.
- 6.2 Entrapment and migration of moisture internally shall be minimized.
  - 6.2.1 Honeycomb internal structure shall be nonperforated.
- 6.3 For any given damage occurrence, damage to the internal structure shall be no more severe than damage to the skin.
- 6.4 If damage to internal structure is expected to accompany skin damage as defined in 5.8, repair material for internal structure must be included in the patch kits.

#### 7.0 TRAILING EDGE

If a separate structural spline is used in the trailing edge, it shall meet the following requirements.

- 7.1 The spline shall be fabricated from corrosion-resistant material, or protected from corrosion so as to remain serviceable for a minimum of five (5) years.
- 7.2 The spline shall suffer no significant damage from impact equivalent to that of a 24-ounce ball-peen hammer allowed to swing freely through a 2-foot arc on a 3-foot radius.
- 7.3 Nicks, scratches, and cracks not extending under the skin shall be repairable by blending. Permissible limits of material removal will be determined from the overall structural characteristics of the blade.

- 7.4 Surfaces exposed by repair shall be protected from corrosion so as to remain serviceable for a minimum of five (5) years.
- 7.5 Repairs requiring replacement of spline structural material shall not be permissible.
- 7.6 Spline material shall be selected so that its crack propagation rate shall allow operation for a minimum of ten (10) hours between failure initiation and complete spline failure, under loads and moments as defined in 1.6.2.

#### 8.0 LEADING-EDGE ABRASION SHEATH

- 8.1 Nonremovable leading-edge protection material shall be capable of operating in the sand and rain environments described in 1.4.2 and 1.4.3 for at least the allowable service life of the blade without being abraded, eroded, or corroded through to its substrate.
- 8.2 Any leading-edge protection material which is not capable of meeting the requirement of 8.1 shall be designed to be removable.
- 8.3 Removable leading-edge protection material shall be capable of operating in the sand and rain environments of 1.4.2 and 1.4.3 for a minimum of 500 hours without being abraded, eroded, or corroded through to its substrate.
- 8.4 For any removable leading-edge sheath, it shall be possible to remove the protection material and clean off its supporting adhesives without any damage to other blade components.
- 8.5 Removable leading-edge sheaths shall be replaced using prepackaged kits including replacement parts, cleaning materials, and adhesives.
- 8.6 Replaced leading-edge sheaths shall be capable of meeting the requirement of 8.3.

#### 9.0 LEADING-EDGE BALLAST

- 9.1 Impact with an immovable object, such as a tree strike, with insufficient energy to bend or severely deform the blade shall not detach the leading-edge ballast from its surrounding structure.
- 9.2 Mechanical retention capable of retaining the leading-edge ballast for a minimum of ten (10) hours under normal centrifugal force, in the event of severe blade damage detaching the adhesive bond between the ballast and surrounding structure, shall be provided.
- 9.3 Removal and replacement of leading-edge ballast shall not be permitted.

#### 10.0 ROOT REINFORCEMENT

- 10.1 If the root reinforcement is designed to be attached outside the basic blade structure, the reinforcement shall be capable of carrying the centrifugal force and bending moments as defined in 1.6.1 for a minimum of ten (10) hours with the reinforcement completely detached from one or the other surface of the blade.
- 10.2 Nicks and scratches shall be repaired by blending. Permissible limits of material removal shall be determined from the structural characteristics of the blade root.
- 10.3 Cracks, dents, and punctures shall be cause for scrapping the blade.
- 10.4 Repairs requiring replacement of material other than nonstructural filler or paint shall not be permissible, and such damage shall be cause for scrapping the blade.

#### 11.0 TIP

- 11.1 Tip covers shall be interchangeable independent of blade disposition. Weights of all tip covers shall fall within a range of .02 pound.
- 11.2 Tip covers susceptible to abrasion, erosion, or corrosion shall remain serviceable for a minimum of 500 hours between replacements in the rain and sand environments described in 1.4.2 and 1.4.3.
- 11.3 Adjustable tip balance weights shall be easily removed and replaced with standard tools normally available at the using unit level.
- 11.4 It shall be impossible to reinstall adjustable tip weights in incorrect locations.

#### 12.0 ADHESIVE SYSTEMS

- 12.1 Adhesives used in the skin and core area shall have a low percentage of volatiles to be compatible with the nonperforated core specified in 6.2.1.
- 12.2 Adhesives subject to environmental deterioration shall be sealed along all exposed bond line edges.
- 12.3 Adhesives used to effect repairs by patching shall be capable of supporting the patch for the allowable service life of the blade under the full spectrum of loads and moments appropriate to the patch location.

- 12.4 Adhesive used to attach a removable leading-edge protection sheath shall be capable of supporting the sheath throughout its replacement life.
- 12.5 Adhesives used to effect repairs shall have cure times compatible with the elapsed time limitation of 1.7.4.
- 12.6 Adhesives used to effect repairs shall utilize heat and pressure sources as defined in 1.7.11.

## APPENDIX II

### RELIABILITY PROGRAM PLAN

This plan presents the method of approach to the analysis of the reliability of the field-repairable/expendable main rotor blade concepts developed under this contract. Together with the maintainability analysis, this reliability analysis will provide the basis for estimating life-cycle costs to develop the cost effectiveness of the various concepts relative to each other and to the standard UH-1H main rotor blade.

The reliability analysis will be based on field experience with the UH-1H helicopter, as presented in Reference 1, modified for differences in design between the field-repairable/expendable concepts and the standard blade.

The analysis performed for the reliability of the concept chosen for hardware development will be refined during the detail design phase and will be further refined at the conclusion of the programs to reflect experience gained during the test phases. The final life-cycle cost analysis will be based on this last refinement.

## INTRODUCTION

The reliability program outlined in this plan is a basic requirement of the field-repairable/expendable main rotor blade development program performed under this contract. The aim of the contract is to develop a main rotor blade concept which will have the best possible cost-effectiveness on a life-cycle basis. The quantitative measure of cost-effectiveness is determined by a life-cycle cost analysis, the basic ingredients of which are the initial procurement cost, the reliability in terms of failure frequency and severity, and the maintainability as measured by the cost and elapsed time for each permissible repair.

The initial reliability analysis will be performed on each of several concepts during the preliminary design studies of Phase I, will be modified, as necessary, for the selected concept during the detail design in Phase II, and will finally be refined in Phase V to incorporate any reliability determinations found during the hardware Phases III and IV.

The field experience gained with the UH-1H rotor blades and reported in Reference 1 will be used as the basis for a failure modes and effects analysis which will then be modified for each of the repairable/expendable concepts, reflecting differences in detail design. The failure modes and effects analysis will include type of failure (dent, scratch, puncture, delamination), cause (inherent, impact, ballistic), location, behavior, classification as to hazard level (negligible, marginal, critical, catastrophic), dependent (secondary) failures, detectability, and probable disposition (repair on aircraft, repair off aircraft, scrap).

Reference 1 will be used as the basis for the failure analysis of the current UH-1H blade. Various samples of the standard blade have been collected and analyzed, giving the best available values for mean-time-between-failure, scrap and repair rates, proportions attributable to different causes, and occurrence of different types of failure. Because different types of data have been presented in different samples, the overall picture of actual field experience will be a composite of the most applicable analyses and tables in Reference 1.

The resulting analysis of the current UH-1H main rotor blade reliability will be theoretical in nature, but will be at least as accurate as any statistical analysis based on comparatively small and relatively diverse samples drawn from a large population. The use of this analysis to compare the field repairable/expendable blade concepts with each other and with the current UH-1H rotor blade is perfectly valid.

All available sources of reliability data will be investigated for suitable information about blades, components, and materials. Among these are Volumes I and II of Reference 11 and various other accumulations of historical records.

### PHASE I EFFORT

During the preliminary concept design studies of Phase I, detail features of the field repairable/expendable blade concepts will be compared with similar features of the UH-1H blade for which service experience has already been determined. Wherever possible, those design details which have contributed to a high failure rate will be avoided, and other materials, components, or assemblies having improved reliability will be substituted. For example, relatively thick reinforced plastic materials may be substituted for thin sheet metal, and resilient non-metallic sheet may replace the vulnerable aluminum foil in the honeycomb core. In areas where corrosion or erosion has been a problem, other materials having greater resistance to such environmental effects will be substituted, if available.

Short term effects will also be considered, in order to avoid critical or catastrophic failures to the greatest extent possible. Materials having low crack propagation rates will be investigated, and fail-safe alternate load paths will be incorporated wherever possible. For example, in choosing between aluminum alloys, certain alloys such as 6061 have low yield strength but also low crack growth rates when compared to higher strength, more commonly used structural alloys such as 2024. Although a reduction in the number

of bonded joints may produce some improvement in inherent reliability, bond lines can be effective crack inhibitors and may provide several parallel load paths which will redistribute the load after a failure, enhancing fail-safety.

#### Standard Blade Experience

From Table E-I, page 77 of Reference 1 the mean-time-between-removals for repair or scrap is established as 914 hours. Since no retirements for time change are included in this sample, and since all repairs of the standard blade are accomplished off the aircraft, the rate of removal is also the rate of failure. Thus, mean-time-between-failures for the current UH-1H main rotor blade will be taken as 914 hours.

From Table H-I, page 112 of Reference 1 it is seen that out of 331 blades removed, 232 were scrapped, 84 were repaired, and the dispositions of 15 were determined later, outside the sample. Thus, of these failures, 232/316 or 73.4% were scrapped, while 26.6% were repaired and readied for service. These proportions are applicable to the total population.

Thus, the rate of failure is  $1/914$  or  $1.094 \times 10^{-3}$  failures per hour, and the rate of scrap is  $.734 \times 1094 \times 10^{-3}$  or  $.803 \times 10^{-3}$  scrapped per blade hour. It can be assumed that the rates

of failure and scrap are constant throughout the service life, so that for a given initial population, the number of blades remaining at any given time diminishes exponentially as service life progresses.

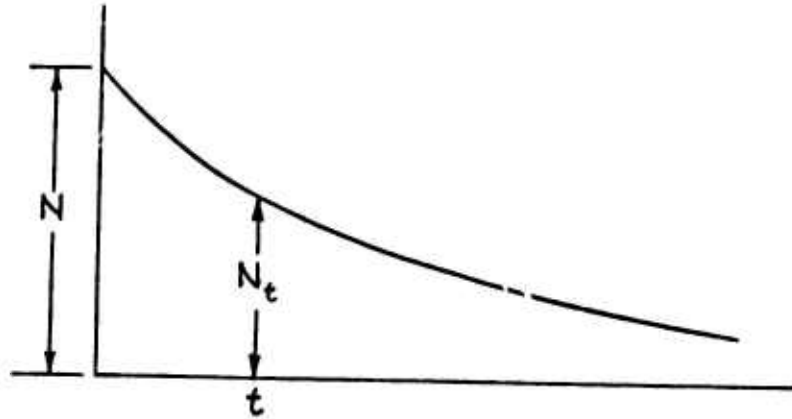

$$N_t = N \cdot e^{-\frac{t}{MTBF_s}}$$

where  $N$  = number in initial population

$N_t$  = number remaining at time  $t$

$MTBF_s$  = mean-time-between-scrap due to failure

Hence, for an allowable life  $T_R$ , the number of blades of the initial population retired for time-expiration is the number remaining at time  $T_R$

$$N \cdot e^{-\frac{T_R}{MTBF_s}}$$

At time  $T_R$  all remaining blades are removed from service and the area under the curve represents the total time on all  $N$  blades.

Total time on all blades thus is

$$N \int_0^{T_R} e^{-\frac{t}{MTBF_s}} dt$$

$$= N \cdot MTBF_s \left( 1 - e^{-\frac{T_R}{MTBF_s}} \right)$$

Since all  $N$  blades have been replaced

$$MTBRep = MTBF_s \left( 1 - e^{-\frac{T_R}{MTBF_s}} \right)$$

where  $MTBRep$  = mean-time-between-replacements

For  $MTBF_s = 1/.803 \times 10^{-3} = 1245$  hours

and  $T_R = 2500$  hours

$MTBRep = 1078$  hours

Rate of replacement	=	1/1078	=	.928 x 10 <sup>-3</sup>	per hour
Rate of retirement	=	(.928 - .803)x10 <sup>-3</sup>	=	.125 x 10 <sup>-3</sup>	per hour
Rate of scrap	=		=	.803 x 10 <sup>-3</sup>	per hour
Rate of repair	=	(1.094 - .803)x10 <sup>-3</sup>	=	.291 x 10 <sup>-3</sup>	per hour
Rate of removal (total)	=		=	1.219 x 10 <sup>-3</sup>	per hour

Mean-time-between-removals for failure or retirement

$$= 1/1.219 \times 10^{-3} = 820 \text{ hours}$$

Referring to Table H-1 of Reference 1, the ratios of scrap to repair are 61:34 for inherent damage and 171:50 for external causes. The sample is too small for smaller subdivision. Table D-1, page 60 of Reference 1, gives a total of 7,329 failure causes. A failure modes and effects analysis will be generated for the current UH-1H blade based on these cause occurrences, with the inherent to external ratio adjusted to conform with Table H-1. Dispositions will be determined so as to conform with Table H-1 also.

Using these criteria, a failure modes and effects analysis can be constructed. The rates of scrap, field repair, and depot repair will conform with Table H-1 of Reference 1. The retirements due to time-expiration will not be incorporated in the failure analysis, but will be an input to the cost analysis. Locations of failures will be determined by the damage scenario specified by the Government.

### Adaptation to New Concepts

For each of the design concepts considered for the field repairable/ expendable main rotor blade, the failure modes and effects analysis, developed to represent the reliability history of the current UH-1H blade, will be examined failure by failure for applicability to the new concept. Where materials are substituted, the depths of damage specified by the damage scenario will be adjusted accordingly, using factors agreed to by the Government.

The survivability of each blade concept will be determined as part of the failure modes and effects analysis. Any increase in the rate of critical or catastrophic failures will be cause for rejection or modification of the concept.

The ultimate disposition of each cause or type of failure will be determined during the maintainability analysis, but will be incorporated in the failure analyses for completeness and to facilitate use in the life-cycle cost analyses.

Comparison between materials and methods of fabrication will be made using, where applicable, accumulated historical reliability data from helicopters having main rotor blades incorporating most commonly used materials and structural systems. Available data includes U.S. Marine Corps 3-M System Data for UH-1E, CH-46, CH-53, AH-1G, and AH-1J helicopters for the two-year period ending in

June 1971, similar data for the Navy TH-57A, and the complete fleet history from introduction to the present for the Navy UH-2 series. Army TAMMS data is available for CH-47A, CH-54A, and OH-6 helicopter types. These collections of reliability and maintenance data include failures by number and cause, an analysis of repair times by man-hours and down-time, and frequencies of aborted missions.

## PHASE II REFINEMENT

When Phase I has been completed and the concept for further development selected, the failure modes and effects analysis developed for that concept will be subjected to failure-by-failure scrutiny during the detail design phase.

As Phase II proceeds, it is expected that as the detail drawings are refined for manufacture, the failure analysis will also be refined to incorporate changes in detail design and to reflect more accurate definition of detail components. This process will continue until the final drawings are completed and released for manufacture.

Because the final design will differ only in detail from the selected concept, the reliability effort during Phase II will not be extensive, and will consist primarily of monitoring minor design changes for reliability and survivability significance.

### FINAL RELIABILITY ANALYSIS

During Phase III, certain bench and whirl tests and the maintainability demonstration will have direct bearing on the reliability analysis. Crack growth rates will be determined during structural bench tests, while the survivability of the blade after suffering damage will be proven during the whirl tests. It is probable that the results of these tests will provide reasons for modification of the assumptions made during the preliminary failure modes and effects analysis, since specific values for crack propagation rates and occurrence of secondary failures will become available. The maintainability demonstration will confirm the maintainability analysis and provide final determination of the scrap or repair dispositions.

Phase IV, the flight test phase, is not expected to affect the reliability analysis, although there is a remote possibility that unexpected secondary failures may be evidenced.

At the conclusion of Phase IV, all indications of incipient or actual failure occurring during the ground or flight tests will be analyzed and their effects on reliability assessed. These effects will be incorporated in the final failure modes and effects analysis for incorporation in the final report, and will form the reliability input to the life-cycle cost analysis of the developed blade design.

## SCHEDULE OF TASKS

The reliability program is broken down into the following basic tasks:

- 1.0 Phase I.
  - 1.1 Failure modes analysis of standard UH-1H blade. (Mode, cause, hazard level, primary, secondary, and total failure rates, inherent, external, and combat rates.) The damage scenario shall be used to determine location and severity of foreign object and ballistic damage.
  - 1.2 Prediction of scrap or repair disposition to conform with UH-1H history.
  - 1.3 Adaptation of the failure modes and effect analysis to each repairable/expendable concept.
  - 1.4 Incorporation of disposition of each failure as determined by maintainability analysis.
  - 1.5 Incorporation of FMEA in Phase I Interim Technical Report.
- 2.0 Phase II.
  - 2.1 Refinement of failure modes and effects analysis for selected concept.
  - 2.2 Incorporation of FMEA in Phase II Interim Technical Report.
- 3.0 Phase III.
  - 3.1 Accumulation of reliability data from bench tests of as-manufactured blades.

SCHEDULE OF TASKS (continued)

- 3.2 Accumulation of survivability data from bench tests of damaged blades.
- 3.3 Accumulation of reliability data from whirl test of damaged blades.
- 3.4 Confirmation of repairability criteria from maintainability demonstration.
- 4.0 Phase IV.
- 4.1 Investigation of any reliability questions occurring during flight test.
- 5.0 Phase V.
- 5.1 The predicted failure modes analysis developed in Phase I and refined in Phase II for the selected field repairable/expendable blade design, shall be revised to incorporate all reliability data accumulated during Phases III and IV.
- 5.2 The finalized failure modes and effects analysis shall be incorporated in the Final Technical Report.

Figure 43 presents the schedule to which these tasks will be performed.

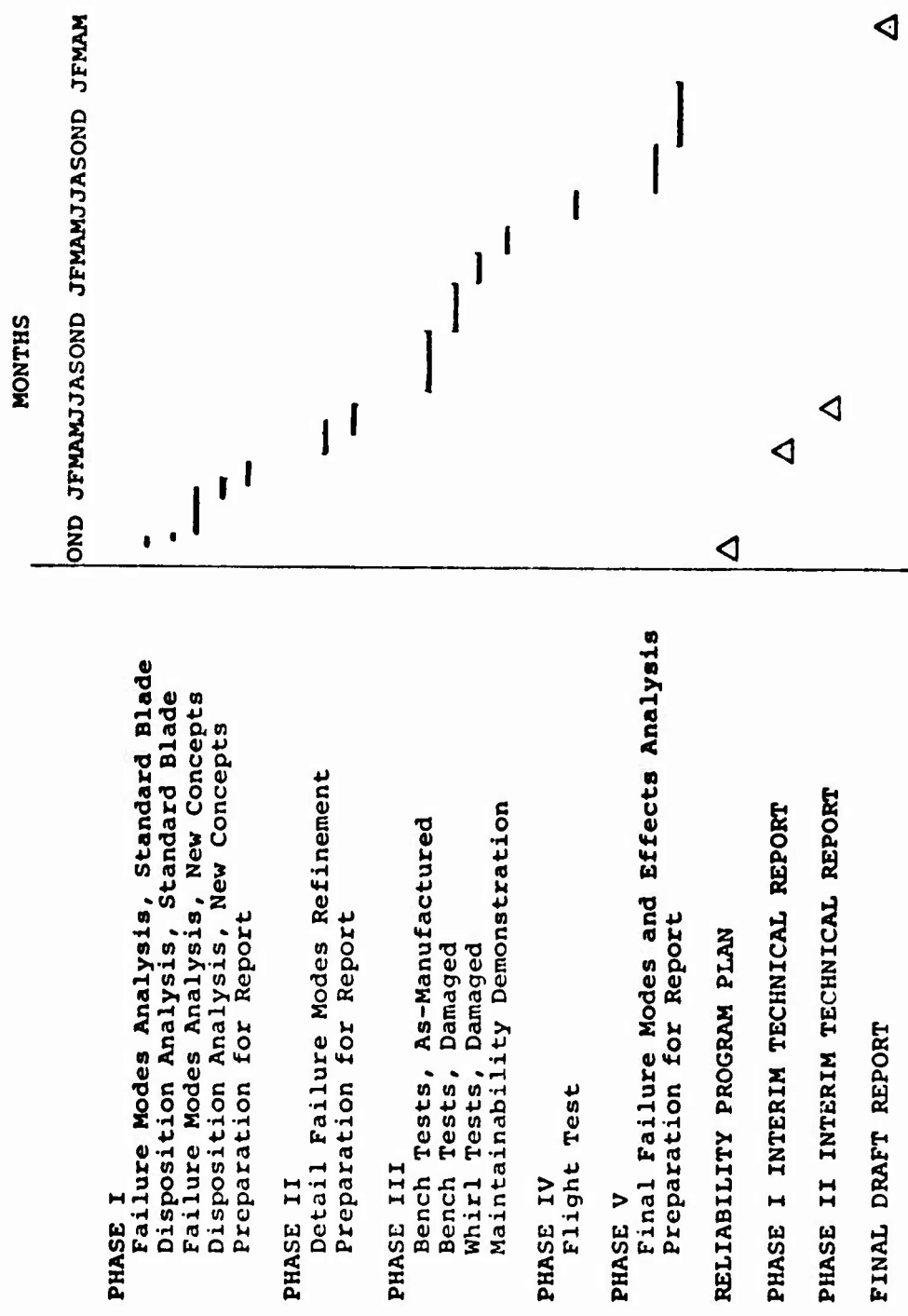

Figure 43. Reliability Program Schedule.

APPENDIX III  
MAINTAINABILITY PROGRAM PLAN

INTRODUCTION

This plan identifies the tasks to be undertaken in the maintainability program for the Field Repairable/Expendable Main Rotor Blade being developed under USAAMRDL Contract No. DAAJ02-73-C-0006. It also delineates the policies, procedures and schedule for accomplishing these tasks.

The objective of this program is to design and develop a helicopter main rotor blade which provides the best overall cost-effectiveness on a life-cycle basis. The quantitative measure of cost-effectiveness is to be determined by a life-cycle cost analysis of competing blade design concepts. Since maintenance and repair represent significant elements in the total cost of operation, maintainability becomes an important factor of design.

The development program will be carried out in five phases. The first of these will evaluate and compare several competing blade concepts. In the second phase the concept selected at the conclusion of the first phase will be designed in detail and manufacturing drawings produced. In the third and fourth phases a prototype quantity of blades will be fabricated and tested on the ground and in flight, demonstrating survivability and maintainability as well as technical adequacy. Finally, in the fifth phase a final analysis and report will be prepared covering all the pertinent data, results, and conclusions generated in the first four phases.

Because many of the maintainability activities span two or more program phases, this plan has been arranged to cover each activity only once and to relate maintainability activities to the appropriate program phases in a Schedule of Tasks at the conclusion of the plan. The organizational and functional relationships of maintainability and other program elements are described at the outset of the plan. The basic philosophy and assumptions governing the application of maintainability to this program are described next, followed by a discussion of statistical techniques and trade-off considerations. The techniques and procedures for conducting maintainability allocations, analysis and predictions are fully described.

The approach toward development of repair kits and equipment is also discussed. A preliminary outline of the maintainability demonstration plan is presented. The Schedule of Tasks concludes the plan.

## ORGANIZATIONAL STRUCTURE

The contractor's Maintainability Engineering is under the Customer Service Department. Personnel assigned to the maintainability project on the field repairable/expendable blade will be administratively responsible to the Supervisor of Maintainability and will functionally work closely with the principal investigator on the program. The success of an R & D program such as this is much influenced by the working relationship and flow of communication between members of the technical team. For this reason, maintainability will be treated as an integral part of the rotor blade concept formulation, design and test. An informal, free exchange of ideas between design engineering and maintainability will be encouraged. Sufficient controls will be maintained, however, to insure that the Army's maintainability goals are achieved. This will include a formal sign-off of engineering drawings by Maintainability prior to release for manufacturing. All design recommendations and trade-offs affecting maintainability will be documented and retained for review by the Army. Maintainability will participate in progress meetings and technical briefings for the Contracting Officer.

### Maintainability Interfaces

Maintainability interfaces importantly with all of the other engineering activities in the program as shown in Figure 44. Reliability Engineering supplies failure rate data and failure modes and effects analyses as input information to the maintainability analysis and prediction. During design reviews and trade-offs, reliability and maintainability jointly assess the impact of design decisions on overall systems effectiveness.

Maintainability input to the Design Engineering group includes qualitative design guidance and quantitative maintainability (repair time) allocations. A continuous interchange of information is maintained between Maintainability and Design Engineering throughout design development. System Test interacts with maintainability continually throughout the installation and test phases of the program, especially during the maintainability demonstrations and test period.

Maintainability also coordinates effectively with other program activities such as Logistics Support and Program Management as shown in Figure 44.

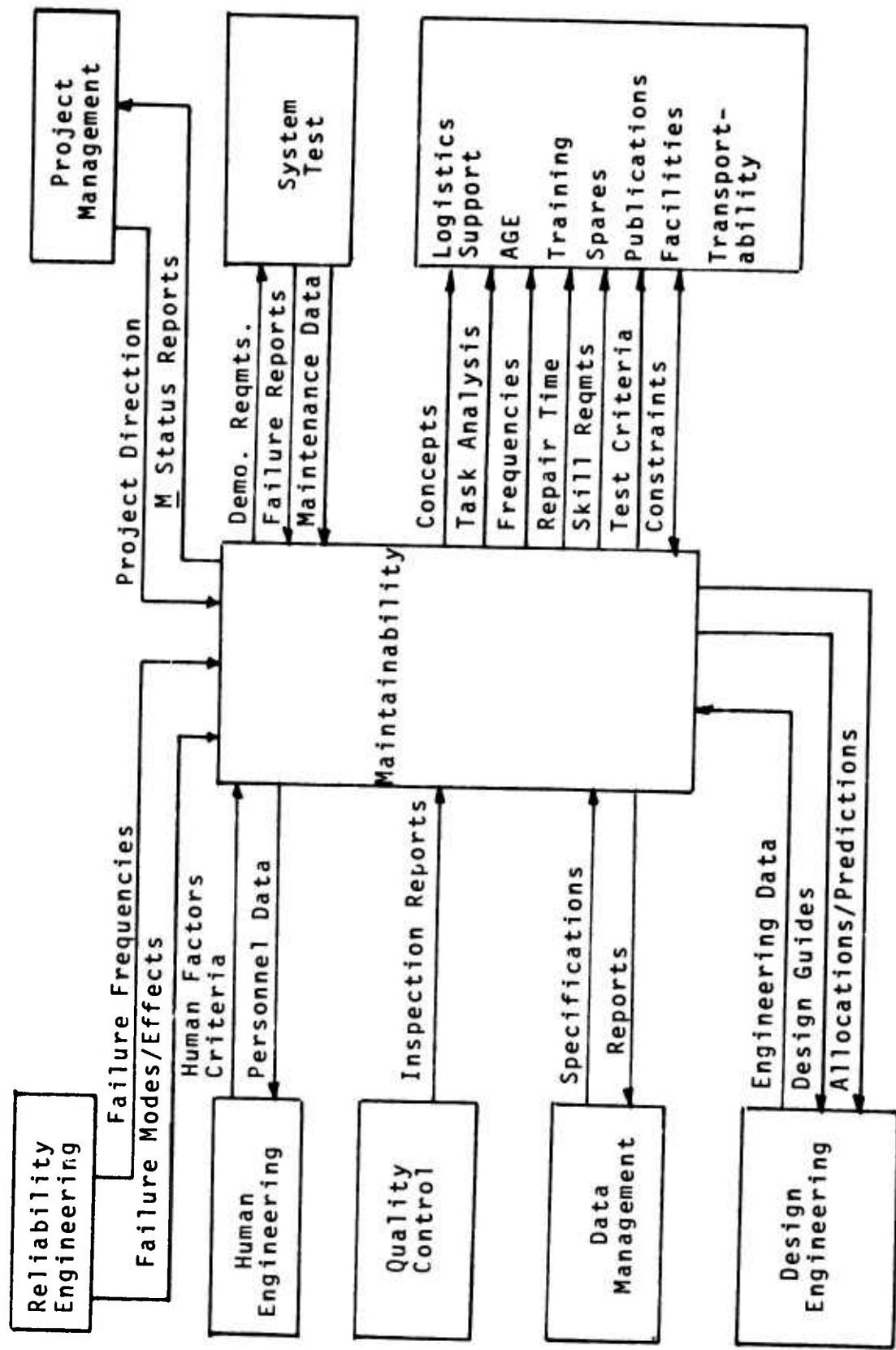

Figure 44. Maintainability Information Flow.

## PHILOSOPHY AND ASSUMPTIONS

One of the premises which must be recognized in the design of a field repairable/expendable main rotor blade is that repairs must be confined largely to those accomplished on the installed blade. Repairs which require removal of the rotor blade are to be avoided since the repair task then becomes more difficult than replacing and scrapping the damaged blade. Despite policies to the contrary, experience shows that maintenance personnel will tend to take the most expedient route to restoring aircraft readiness, particularly under the stress of field operations. This being the case, repair of the rotor blade will be undertaken primarily when blade replacement becomes a more difficult and time-consuming alternative.

The design philosophy adopted in this program should seek to make the repair-or-scrap decision obvious to the mechanic. This suggests that design for expendability be pursued when the alternative is an involved off-aircraft repair. Conversely, repairability is the preferred approach when the repair lends itself to a relatively simple, quickly performed task on the installed rotor. Economic considerations may not permit rigid adherence to this philosophy in every instance, however. The ultimate aim is to provide the best overall cost-effectiveness and the maintenance policy must be consistent with this objective.

The maintenance concept specified by the Army for the field repairable/expendable main rotor blade allows a maximum corrective maintenance time,  $M_{max}$ , at the 95th percentile of 3 hours. This is to include the tasks of locating, isolating and correcting the fault (including any adhesive cure time) and placing the aircraft in an operational status.

In the UH-1 Rotor Blade Design Cost Comparisons the man-hours required to remove and install the UH-1 rotor blade is given as 7.5 man-hours. Assuming an average of two men for this task, the elapsed time for blade removal and installation is 3.75 hours. In design of the field repairable/expendable blade, the repairability/expendability ratio will be dictated by the cost-effectiveness characteristics of various design approaches, moving in the direction of expendability as the cost of scrapping the blade becomes less than that of repair.

Obviously, the selected concept might conceivably be a completely expendable rotor blade, one whose cost of fabrication was so low that scrapping the blade would be economically justified whenever damage exceeded minor surface repair. With an expendable rotor blade, the maintenance task in the

event of damage or failure is to replace the blade. But, this task alone exceeds the 95th percentile corrective maintenance time specified by the Army.

Since it is not within the scope of this contract to improve the design of the blade installation, there is no opportunity for reducing replacement time other than to perhaps facilitate the balancing and tracking tasks to some degree. It might be possible to recommend improvements in the maintenance procedures associated with blade replacement, although the possibilities here are very remote in view of the Army's long experience with the UH-1 aircraft. It is reasonable to conclude, therefore, that the time required to remove and install the rotor blade should be accounted for in the  $M_{max}$  analysis only when removal is required to effect an off-aircraft repair. In cases where the blade is scrapped, replacement time will not be applied against  $M_{max}$  (although it will be included in the cost modeling).

## QUANTITATIVE MAINTAINABILITY ANALYSIS

### RATIONALE FOR THE LOGNORMAL DISTRIBUTION

One of the basic requirements in developing a maintainability program plan for the field repairable/expendable main rotor blade was to decide upon the methodology for conducting the quantitative analysis of maintainability. Some of the contractor's earlier work in this area was used as a basis for developing the quantitative approach.

In 1969, the contractor participated as a subcontractor in design of airframe components for the Navy F-14A aircraft. One requirement of the contract was to conduct a maintainability analysis and prediction for the component subsystems. A review of existing maintainability prediction techniques, principally those contained in MIL-HDBK-472, showed none to be entirely suited to applications involving mechanical systems. Most of these procedures employed analytic methods which were basically electronics oriented or which utilized equations developed through studies of electronics systems. The standard prediction techniques suffered other deficiencies as well in that they frequently failed to encompass one or more of the maintainability parameters called for by the specifications.

Accordingly, it was decided to undertake development of a new maintainability prediction technique for the F-14A program. Several basic objectives were sought in development of the technique:

1. To make the technique applicable to mechanical systems and components, particularly the structural type of components which would comprise the majority of the contractor's work on the F-14A.
2. To make the technique compatible with the maintainability analysis requirements of the specifications.
3. To utilize as much of existing maintainability prediction techniques as possible so to build on that which had already proven successful.

The initial step in developing the prediction technique was to study the repair time distributions of typical aircraft systems. The data base for this analysis was the actual maintenance records supplied by the Navy on two models of the H-2 helicopter for a six-month period ending December 1968.

Approximately 33,000 maintenance records were analyzed, representing nearly 16,000 flight-hours of aircraft utilization. Tables XIX and XX show the aircraft systems covered by the analysis and the number of individual repair time records included in each sample.

Many studies had been conducted by both the industry and the military to measure the probability distribution associated with maintenance time. The general consensus was that time-to-repair of military systems was found most often to conform to the lognormal distribution. This conclusion was confirmed by the analysis of H-2 helicopter maintenance histories.

A computer program was written to fit by the method of least-squares, a lognormal probability distribution to a sample of elapsed repair times. All 52 systems listed in Tables XIX and XX were processed by the program. It was found, without exception, that the lognormal yielded a good fit to the sample data on each system. Figures 45 and 46 are plots of the analysis on two systems of the twin-engine UH-2C helicopter, the air-frame and rotors respectively. Shown in each figure are the frequency distribution of the reported repair times together with the cumulative lognormal function fitted by least-squares. The fit of the smooth curve to the reported data is observed to be good in both cases. Similar results were obtained with the other systems analyzed including engines, hydraulics, electrical and avionics, substantiating the hypothesis that the population of repair times were, in fact, well described by the lognormal distribution.

The observation that repair times were lognormally distributed for the entire spectrum of systems covered by the analysis was an important conclusion for the work which was to follow. It suggested that repair time was not a function of hardware characteristics alone but was very much influenced by use and environmental factors shared by all systems.

The conclusions of the H-2 helicopter repair time analysis were considered directly applicable to the field repairable/expendable rotor blade program. They indicated that it was reasonable to base the quantitative maintainability analysis on the assumption that the population of repair tasks for the rotor blade (treated as a system) would be lognormally distributed.

TABLE XIX. MAINTAINABILITY ANALYSIS DATA BASE, UH-2A/2B HELICOPTER

System	MTR	log MTR	$\bar{X}$	$\sigma^2$	Number Actions
11 Airframe	2.74	.4379	.1498	.1962	2688
12 Fuselage Compartments	1.76	.2465	.0167	.1552	434
13 Landing Gear	1.77	.2470	.0571	.1369	1199
14 Flight Controls	2.76	.4413	.1718	.1927	828
15 Rotors	1.95	.2899	.1090	.1332	3408
22 Engines	3.06	.4856	.1306	.2430	748
26 Drives	2.61	.4165	.1385	.2021	1353
29 Power Plant Installation	1.77	.2491	.0302	.1421	723
42 Electrical Power	2.10	.3217	.1057	.1465	965
44 Lighting	1.11	.0454	-.0829	.0833	631
45 Hydraulic Power	1.66	.2208	.0858	.1090	113
46 Fuel	2.21	.3449	.0738	.1728	558
49 Misc. Utilities	1.92	.2849	.0737	.1518	763
51 Instruments	1.76	.2467	.0510	.1281	1148
57 ASE	1.91	.2812	.0934	.1340	453
61 HF Communications	1.62	.2102	.0456	.1253	93
63 UHF Communications	1.85	.2673	.0227	.1404	523
64 Interphone	1.38	.1411	-.0345	.1010	374
65 IFF Systems	2.08	.3174	.1428	.1353	82
71 Radio Navigation	2.08	.3172	.1033	.1512	636
72 Radar Navigation	1.86	.2704	.0704	.1344	926

TABLE XIX - Continued

System	MTRR	COV NUMBER	$\bar{X}$	$\sigma_x^2$	Number Actions
73 Bombing Navigation	1.46	.1646	.0473	.0955	107
74 Weapons Control	1.47	.1668	.0122	.1265	22
91 Emergency Equipment	0.94	.0254	-.1008	.0660	74
97 Explosive Devices	1.68	.2261	.0135	.1411	59
All Systems	2.12	.3253	.0899	.1584	18908

TABLE XX. MAINTAINABILITY ANALYSIS DATA BASE, UH-2C HELICOPTER

System	MTTR	log MTTR	$\bar{X}$	$\sigma_x^2$	Number Actions
11 Airframe	1.86	.2690	.0744	.1335	1595
12 Fuselage Compartments	1.54	.1869	.0354	.1082	351
13 Landing Gear	1.48	.1691	.0262	.1037	908
14 Flight Controls	2.33	.3674	.1546	.1550	632
15 Rotors	1.96	.2915	.1062	.1274	2460
22 Engines	2.21	.3448	.0377	.1861	819
26 Drives	2.81	.3379	.0784	.1639	1059
29 Power Plant Installation	1.39	.1431	.0095	.0965	850
42 Electrical Power	1.60	.2031	.0478	.1010	513
44 Lighting	1.03	.0117	-.0913	.0686	380
45 Hydraulic Power	1.53	.1848	.0336	.1073	95
46 Fuel	1.65	.2166	.0030	.1274	741
49 Misc. Utilities	1.55	.1900	.0315	.1149	464
51 Instruments	1.41	.1486	-.0037	.0961	891
57 ASE	1.37	.1359	.0062	.0990	429
61 HF Communications	1.14	.0577	-.0274	.0749	50
63 UHF Communications	1.17	.0679	-.0677	.0740	430
64 Interphone	0.89	-.0510	1470	.0619	261
65 IFF Systems	1.63	.2132	.0912	.0890	71
71 Radio Navigation	1.84	.2638	-.0062	.1310	399

TABLE XX - Continued

System	MTTR	log MTTR	$\bar{X}$	$\sigma_x^2$	Number Actions
72 Radar Navigation	1.59	.2008	.0099	.1165	591
73 Bombing Navigation	1.65	.2182	.0313	.1104	57
74 Weapons Control	1.83	.2627	.0800	.1279	58
91 Emergency Equipment	1.20	.0775	-.0749	.1064	67
97 Explosive Devices	1.06	.0244	.0477	.0583	38
All Systems	1.72	.2358	.0417	.1252	14209

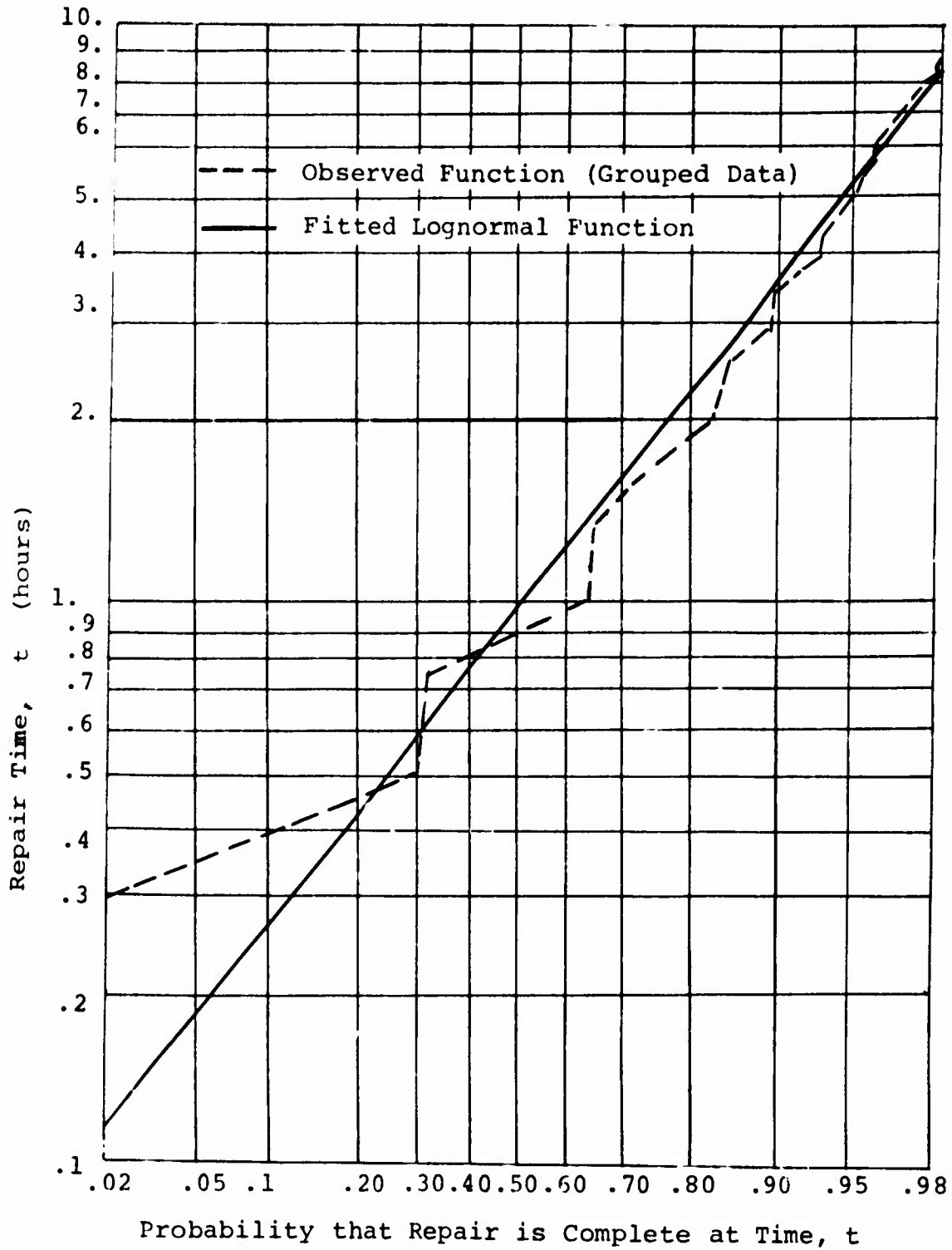

Figure 45. Observed Repair Time Distribution for the UH-2C Airframe System and Fitted Lognormal Distribution.

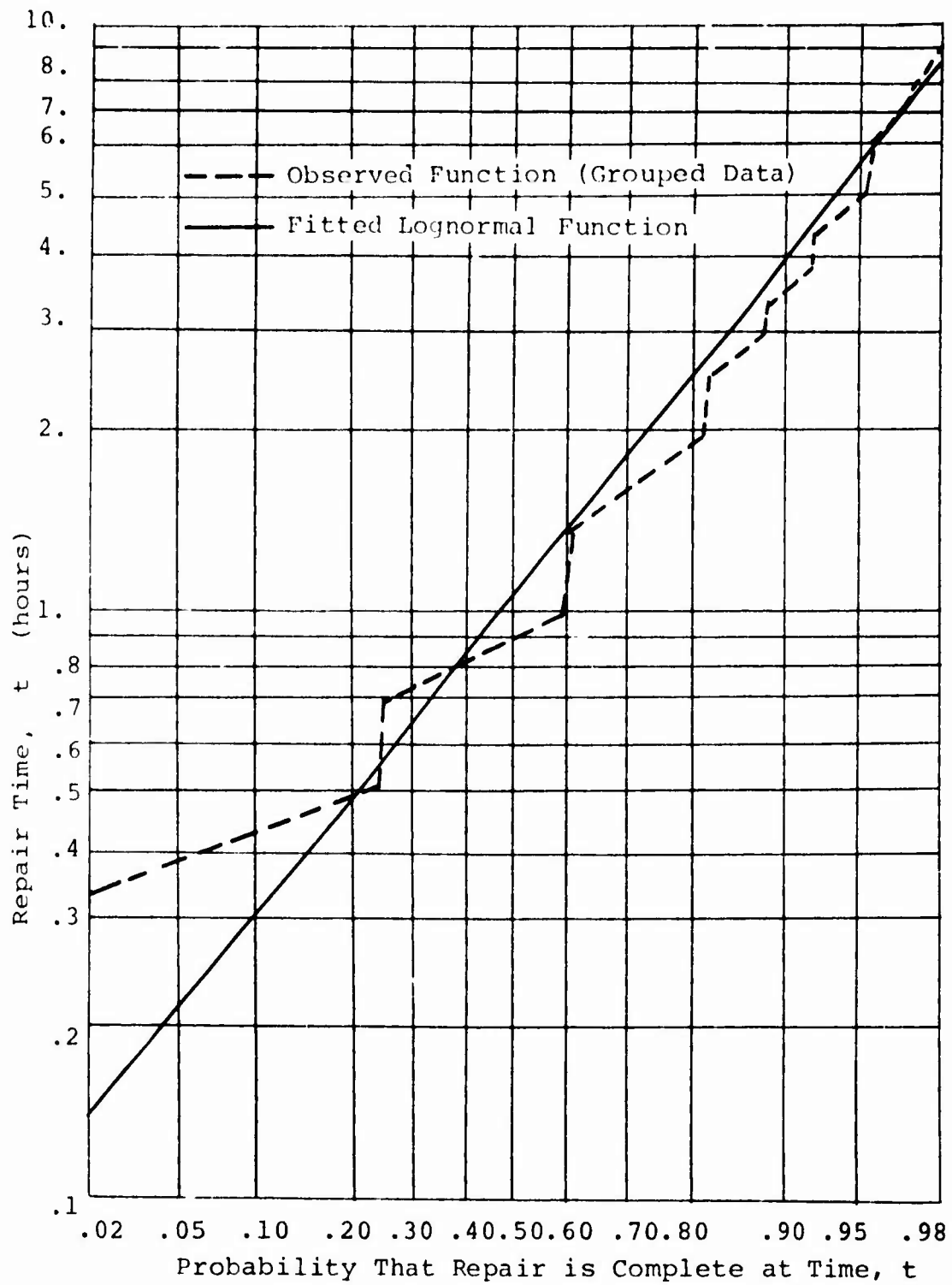

Figure 46. Observed Repair Time Distribution For The UH-2C Rotor System and Fitted Lognormal Distribution.

## MAINTAINABILITY INDICES

The maintainability indices to be specified and controlled in design of the field repairable/expendable rotor blade involve both the frequency and time required for maintenance.

### Frequency Indices

#### Mean-Time-Between-Maintenance-Preventive (MTBM<sub>p</sub>)

Preventive maintenance is defined as any maintenance, excluding inspection, performed on an established periodic schedule required to maintain the rotor blade in a safe operating condition. This would include such functions as scheduled lubrication, routine tracking or balancing and replacement for expiration of fatigue life. MTBM<sub>p</sub> is the average flight-hour interval between preventive maintenance actions on the rotor blade.

$$MTBM = \frac{N_p}{\sum_{i=1} f_{pi}} \quad (1)$$

where  $f_{pi}$  = the frequency of the  $i^{\text{th}}$  preventive maintenance task in actions per flight-hour.

$N_p$  = the number of distinct preventive maintenance actions.

#### Mean-Time-Between-Maintenance-Corrective (MTBM<sub>c</sub>)

Corrective maintenance is defined as any action required to restore the aircraft to operating condition after the occurrence of damage or failure to the rotor blade. This includes unscheduled adjustments, alignment or tracking and repair or replacement (for repair) of the rotor blade. The mean-time-between-maintenance corrective is a function of the mean-time-between-failure (MTBF) for inherent and external causes. The MTBM<sub>c</sub> is equivalent to the MTBF when each failure is corrected independently, i.e., there is no simultaneous correction of multiple failures in a single action.

$$MTBM_C = \frac{1}{\sum_{i=1}^{N_C} f_{C_i}} = MTBF \quad (2)$$

where  $f_{C_i}$  = the frequency of the  $i$ th failure (or damage) mode in events per flight-hour.

$N_C$  = the number of distinct corrective maintenance actions.

#### Mean-Time-Between-Maintenance (MTBM)

The mean-time-between-maintenance is the average flight-hour interval between preventive and corrective maintenance actions on the rotor blade:

$$MTBM = 1 / [(1/MTBM_p) + (1/MTBM_C)] \quad (3)$$

#### Mean-Time-Between-Removal (MTBR)

The mean-time-between-removal is the average flight-hour interval between removal of the rotor blade for the following purposes:

- Inspection
- Scheduled Retirement
- Unscheduled Repair
  - . Material (Inherent) Failure
  - . External Failure (Non-Combat)
  - . External Failure (Combat)
- Scrap
  - . Material (Inherent) Failure
  - . External Failure (Non-Combat)
  - . External Failure (Combat)

### Repair Time Indices

Quantification of maintainability attempts to describe attributes of design which contribute to the ease or difficulty with which maintenance is performed. The common approach to doing this is to measure the time elements involved in the execution of maintenance and from these measurements to develop some general conclusions with regard to maintainability characteristics. Typical measures of maintenance time include man-hours per flight-hour, mean repair time, maximum repair time and average availability. Each of these statistics requires a knowledge of the population or distribution of repair times exhibited by the particular system or equipment. For the repairable/expendable rotor blade, it will be assumed, based on the rationale offered earlier, that repair times are log-normally distributed.

By definition, the density function for  $x$ , ( $x = \log_{10} t$ ) normally distributed with mean,  $\bar{x}$ , and standard deviation,  $\sigma_x$  is:

$$f(x, \bar{x}, \sigma_x) = \left( \frac{1}{\sigma_x \sqrt{2\pi}} \right) \exp \left[ - \frac{(x - \bar{x})^2}{2 \sigma_x^2} \right] dx \quad (4)$$

where

$$x = \log_{10} t$$

$$t = \text{elapsed task time}$$

$$\bar{x} = \text{mean value of } x$$

$$\sigma_x = \text{standard deviation of } x$$

The mean value of  $x$  is the arithmetic average of the logarithms of  $t$ :

$$\bar{x} = \frac{1}{N} \sum_{i=1}^N (\log_{10} t_i) \quad (5)$$

where  $N =$  the number of maintenance actions.

The variance of  $x$  is expressed as:

$$\text{Var } x = \sigma_x^2 = \frac{\sum_{i=1}^N (x_i - \bar{x})^2}{N} \quad (6)$$

The standard deviation of  $x$  is simply the square root of the variance of  $x$ .

$$\sigma_x = \sqrt{\sigma_x^2}$$

The mean value of  $t$  is the arithmetic average of the repair times:

$$\text{MTTR} = \frac{\sum_{i=1}^N t_i}{N} \quad (7)$$

The maximum repair time,  $M_{\text{max}}$ , is defined as the 95th percentile repair time.

$$M_{\text{Max}} = \log_{10}^{-1} (\bar{x} + 1.645 \sigma_x) \quad (8)$$

where 1.645 is the  $z$  value corresponding to the 95th percentile of the cumulative distribution.

#### Mean Preventive Maintenance Downtime ( $\bar{M}_{\text{pt}}$ )

The mean preventive maintenance downtime is the average calendar time the system is down for preventive maintenance on the rotor blade. It includes only productive maintenance time.

$$\bar{M}_{pt} = \left( \sum_{i=1}^{N_p} t_{pi} \right) / N \quad (9)$$

where  $t_{pi}$  = elapsed time required to perform the  $i$ th preventive maintenance task.

Mean Active Corrective and Preventive Action Time ( $\bar{M}$ )

The mean active corrective and preventive maintenance time is the average calendar time the system is down for both types of maintenance. It includes only productive maintenance time.

$$M = \frac{MTTR (f_c) + \bar{M}_{pt}(f_p)}{f_c + f_p} \quad (10)$$

where  $f_c$  and  $f_p$  are the number of corrective and preventive maintenance tasks in the same flight-hour period.

Maintenance Man-Hours Per Flight-Hour (MMH/FH)

The maintenance man-hours per flight-hour is defined as:

$$MMH/FH = \sum_{i=1}^{N_c} MMH_{ci} (f_{ci}) + \sum_{i=1}^{N_p} MMH_{pi} (f_{pi}) \quad (11)$$

where  $MMH_{ci}$  = man-hours required to perform the  $i$ th corrective maintenance task.

$MMH_{pi}$  = man-hours required to perform the  $i$ th preventive maintenance task.

## Analysis of Variance

The basic quantity in maintainability prediction is the task time estimate. In keeping with the philosophy of existing maintainability prediction methods, a basic assumption is that a qualified and experienced analyst is able to reliably estimate the time required to complete simple tasks. The accuracy of such estimates will increase with the analyst's knowledge of the system, its intended environment and use.

During the early design stages, maintenance requirements are tentatively identified and gross task time estimates are made to arrive at a "ballpark" maintainability prediction. As the design solidifies, more accurate estimates are possible and the prediction is refined. This iterative process is continued until the design is finalized and an in-depth analysis of maintenance tasks is made to yield the final maintainability prediction. At each stage of the evolution, predictions are compared to allocated values to determine whether the design is meeting established goals and to reallocate values where necessary.

While an experienced analyst is able to estimate quite accurately the average time to perform a maintenance task, he is likely unable to estimate the amount of variance that might be expected in performance of that task. In order to do this he would need to envision the most optimistic and the most pessimistic circumstances under which the task might be performed and from this to reach some conclusion in regard to the average deviation from the mean performance time that could be anticipated. Clearly, any such judgments would be largely subjective and lacking validity.

Maintainability predictions based on the lognormal distribution using MIL-HDBK-472, Procedure II, utilize a fixed standard deviation,  $\log_{10}$  of 0.55 derived from analyses of maintenance tasks on shipboard and shorebased electronic equipment. The studies of helicopter maintenance activity conducted on the F-14A program indicate, however, that the variance is not constant but varies with changes in the mean repair time.

Figure 47 is a scatter plot of the variance,  $\text{Var } x$ , versus the mean of the logarithms,  $x$ , from the 52 data points in Tables I and II. Figure 48 is a scatter plot of the variance,  $\text{Var } x$ , versus the log of the mean-time-to-repair,  $\log_{10} \text{MTTR}$ , for the same sample of data. A computer time-share program was used to test the goodness-of-fit of the data points to standard statistical distributions using the method of least-squares and, from this, to derive regression equations for  $\text{Var } x$ . The curve yielding the best fit in each case is shown in the two figures.

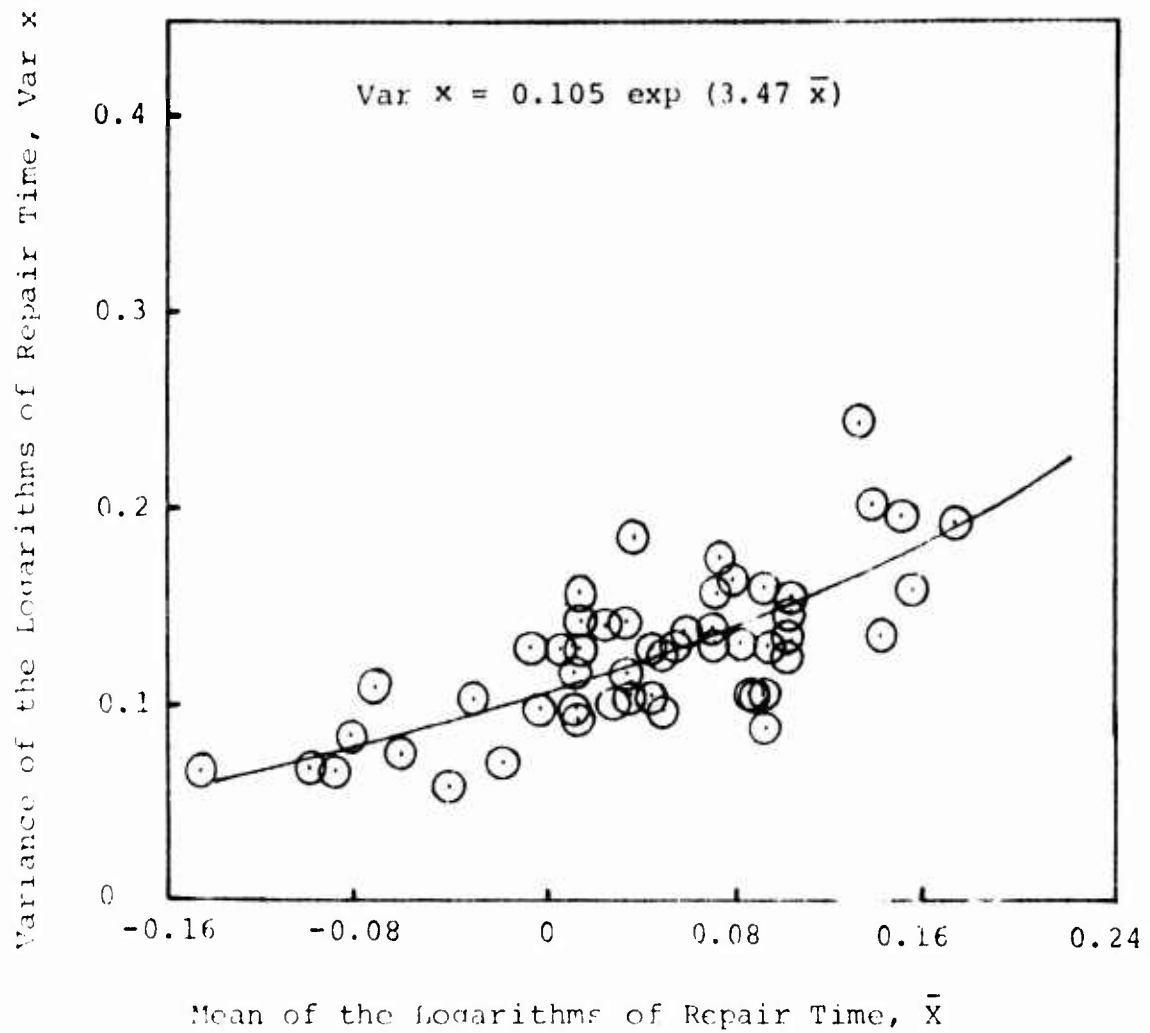
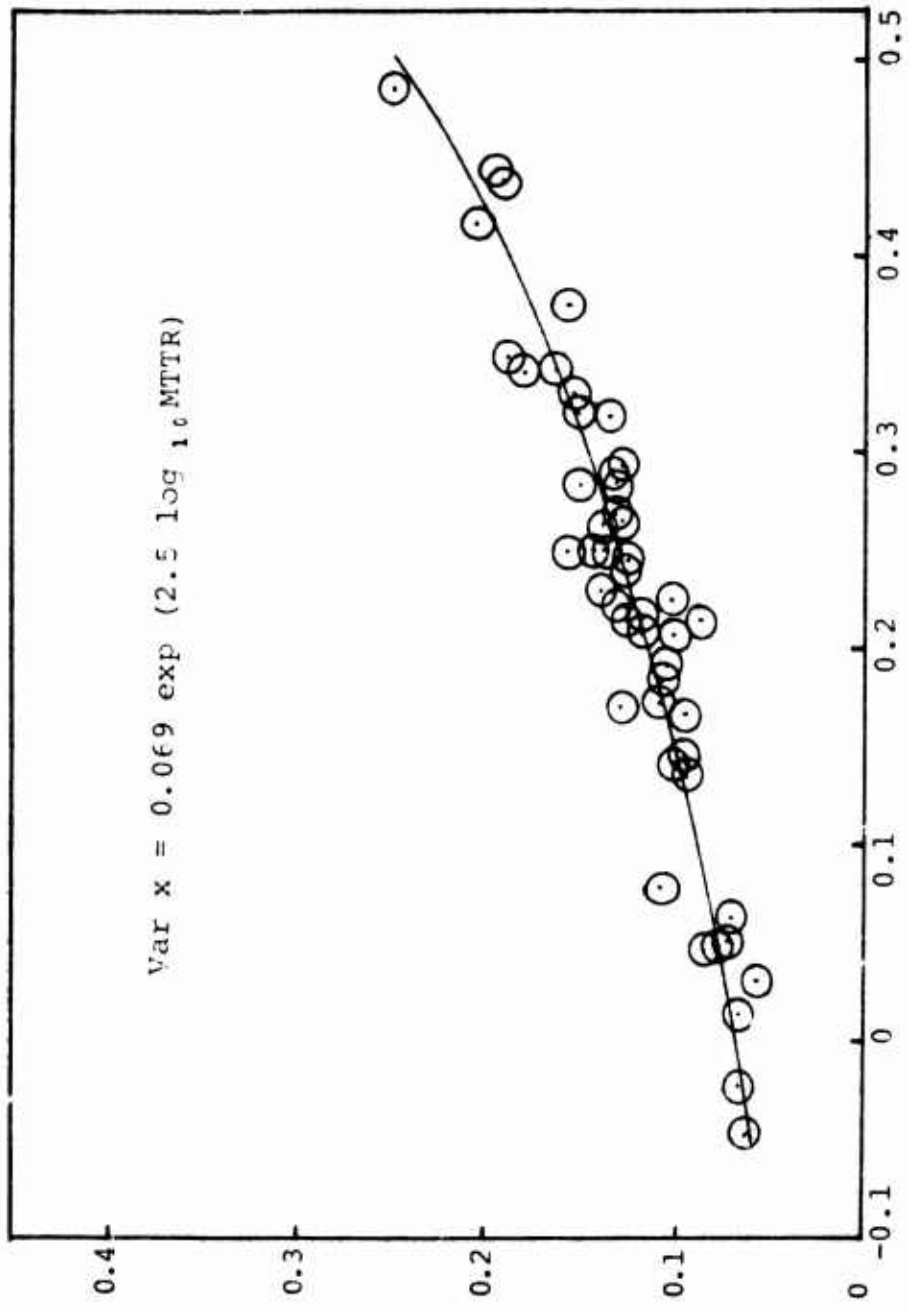

Figure 47. Variance of the Logarithms of Repair Time,  $\text{Var } x$ , Versus the Mean of the Logarithms,  $\bar{x}$  for 52 UH-2C Helicopter Subsystems.

Variance of the Logarithms of Repair Time, Var x



Logarithm of the Mean-Time-To-Repair, log<sub>10</sub> MTTR

Figure 48. Variance of the Logarithms of Repair Time, Var x, Versus the Logarithms of the Mean-Time-To-Repair, log<sub>10</sub> MTTR, for 52 UH-2C Helicopter Subsystems.

The two sets of sample points both correlated best to an exponential function. Much better correlation was obtained from the regression of Var x on log MTTR, however. It is intuitively reasonable that the variance of the lognormal distribution be related more to the mean repair time rather than the median or mean of the logarithms, since the mean repair time accounts for extreme values while the median does not. Moreover, the mean repair time should be indicative of the relative complexity of the task and the variability in task performance should be related to its complexity. The regression equation developed from this analysis is:

$$\sigma_x^2 = .06917 \exp (2.5 \log_{10} \text{MTTR}) \quad (12)$$

Using this expression, the analyst is able to predict the repair time variance as a function of the estimated mean repair time and, from this, to obtain an estimate for  $M_{\max}$ .

Some limitations to the foregoing analysis should be mentioned. First, the sample data covers basically 26 subsystems of two similar models of the H-2 helicopter. Although the data represents a broad range of aircraft hardware and is believed to be typical of military aircraft maintenance experience in terms of employment and environment, a larger or substantially different sample may have produced other results.

Secondly, the data sample included a relatively narrow range of subsystem repair time mean values (approximately 0.9 hours to 3.0 hours). The regression equation for the variance is believed to be valid for this range of values, but its application to values much outside this range, especially larger ones, cannot be substantiated. It is recognized, moreover, that a definite distortion occurs in the larger range as a result of using an exponential regression equation. Increases in  $\log_{10} \text{MTTR}$  generate rapidly larger increases in Var x which ultimately begins to warp the distribution ( $\bar{x}$  reaches a maximum value and then becomes smaller with increasing values of MTTR). A linear regression of Var x on  $\log_{10} \text{MTTR}$  was observed to produce seemingly better results for large values of MTTR. There was no available data with which to explore this, however. Because the regression equation for Var x was developed with a limited data sample, it is considered valid only for MTTR in the range of zero to approximately five hours.

The final limitation concerns the point of application for predicting Var x in an analysis of maintainability. The study upon which the prediction method was developed, dealt only with populations of repair tasks on entire systems. No

analysis was made of the distributions associated with individual repair tasks. While the study results tend to support the assumption of a lognormal distribution for the population of repair tasks on any aircraft system of moderate to large complexity, the assumption of the lognormal may not be valid for individual repairs. Thus, the estimate of  $\text{Var } x$  (and  $M_{\text{max}}$  therefore) should be made at the system level based on the aggregate of all repair tasks being considered.

The significance of the variance in the maintainability analysis of the repairable/expendable rotor blade is illustrated in Figure 49. The cumulative distribution function is plotted for an  $M_{\text{max}}$  of 3.0 hours (95th percentile) at two different values of  $\sigma_x$ . One curve is based on a  $\sigma_x$  of .55 as prescribed by MIL-HDBK-472, Procedure II. The second curve is based on a  $\sigma_x$  of .296 as derived from the Kaman regression equation for the variance. As shown, the median,  $\bar{t}_g$ , and mean repair time, MTTR, are much smaller for the distribution with the larger variance. If MIL-HDBK-472, Procedure II, variance is used as the criterion for allocating maintainability parameters, therefore, the average repair task must not exceed 0.82 hours MTTR. If, on the other hand, the smaller estimate of the variance is more realistic, an MTTR of approximately 1.25 hours can be tolerated.

The basic approach to maintainability prediction prescribed by MIL-HDBK-472, Procedure II, will be followed in the field repairable/expendable main rotor blade analysis except that the variance will be predicted as a function of the estimated MTTR using the regression equation of (12).

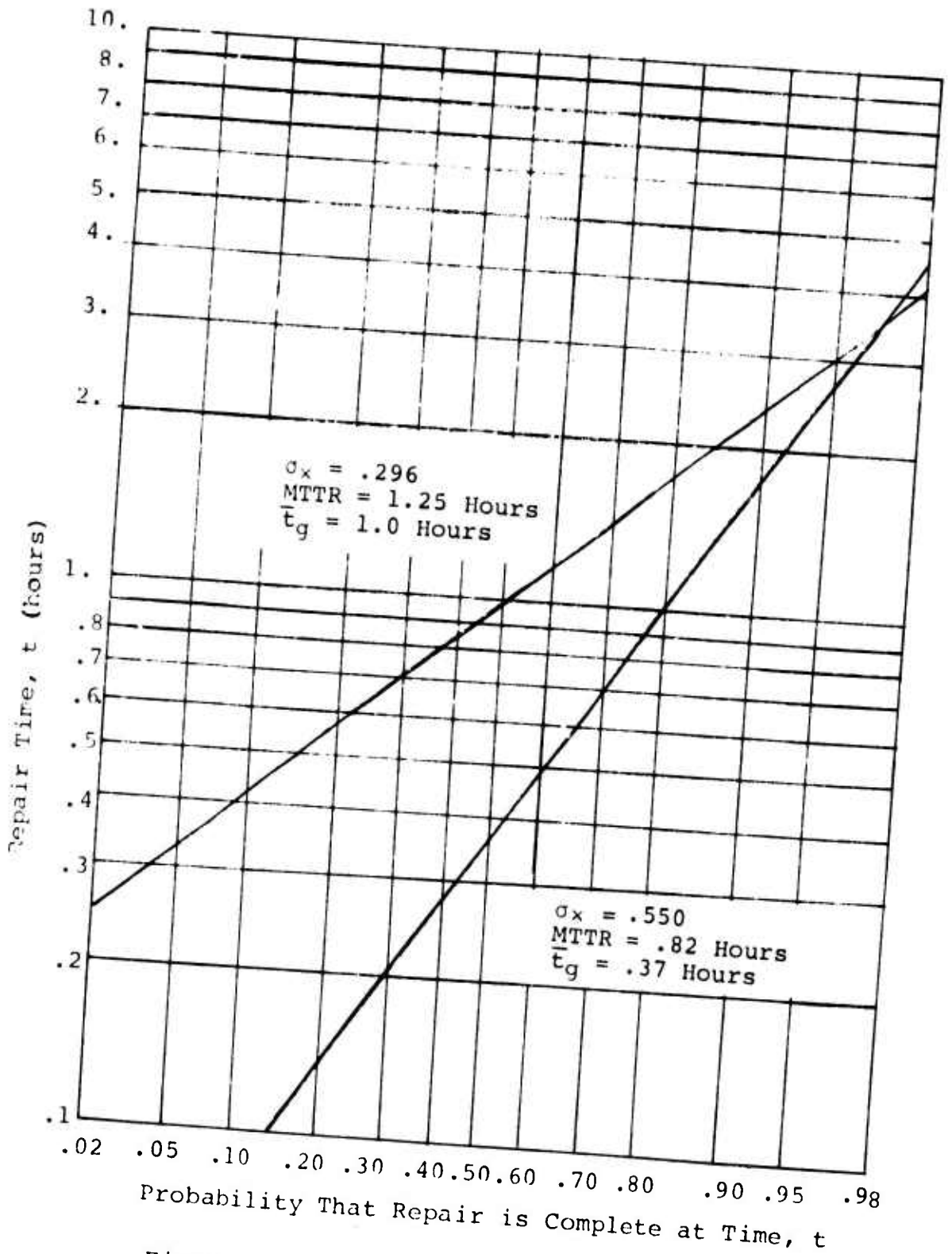

Figure 49. Cumulative Repair Time Distributions for  $M_{\max}$  of 3.0 Hours at Two Different Values of  $\sigma_x$ .

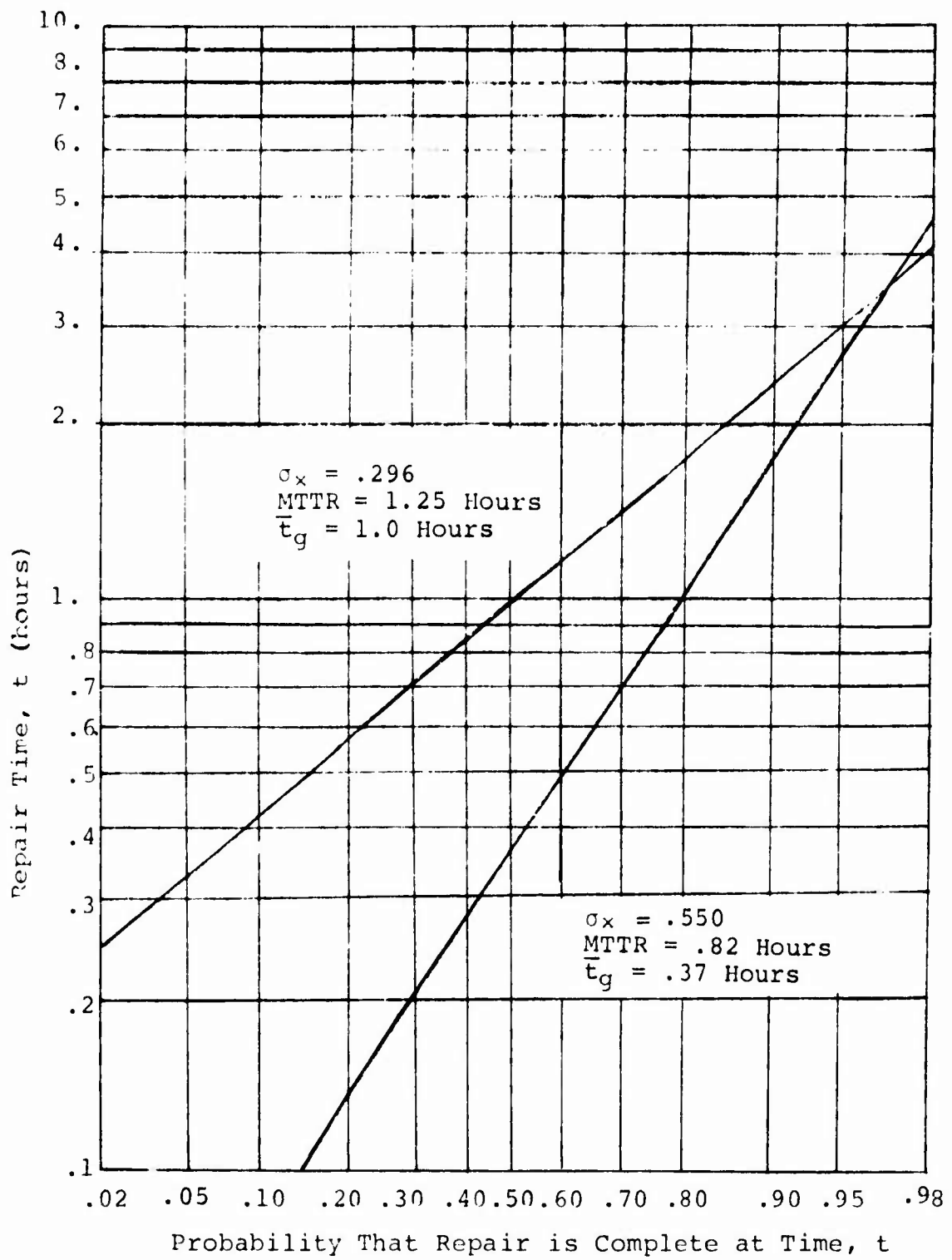

Figure 49. Cumulative Repair Time Distributions for  $M_{max}$  of 3.0 Hours at Two Different Values of  $\sigma_x$ .

## MAINTAINABILITY TRADE-OFFS

The Army's quantitative maintainability requirement for the field repairable/expendable rotor blade is specified only in terms of  $M_{\max}$ , the 95th percentile corrective maintenance time. Confining the quantitative expression of maintainability to the parameter  $M_{\max}$  provides much needed flexibility in design of the rotor blade and associated repair techniques.  $M_{\max}$  can be controlled both in terms of the average task duration and the variability in task performance. A larger mean task time can be tolerated if the variance in task performance can be kept small. With a fixed  $M_{\max}$ , the expected variance will define the mean-time-to-repair, MTTR.

Figure 50 shows the area of tradeoff between MTTR and the variance for a lognormal repair time distribution at  $M_{\max}$  values (95th percentile) of 3 hours, 2 hours and 1 hour. MTTR is shown plotted against the standard deviation of the logarithms (base 10) of repair time,  $\sigma_x$ . Also shown is a plot of the geometric mean repair time,  $\bar{t}_g$  versus  $\sigma_x$ . The plot of  $\bar{t}_g$  is defined by the equation:

$$\bar{t}_g = \log_{10}^{-1} (\log_{10} M_{\max} - 1.645 \sigma_x) \quad (13)$$

and the plot of MTTR by the equation:

$$\text{MTTR} = \log_{10}^{-1} (\log_{10} M_{\max} + 1.15 \sigma_x^2 - 1.645 \sigma_x) \quad (14)$$

The area under the MTTR curves is the mean/variance tradeoff area. The shaded area represents the values considered to be within the realistic range of alternatives. Also shown is a plot of the regression equation used to predict the variance in repair time as a function of the MTTR (see section on Analysis of Variance). The portion of this curve which intersects the potential tradeoff area shows the region of the most likely mean/variance combinations based on past history.

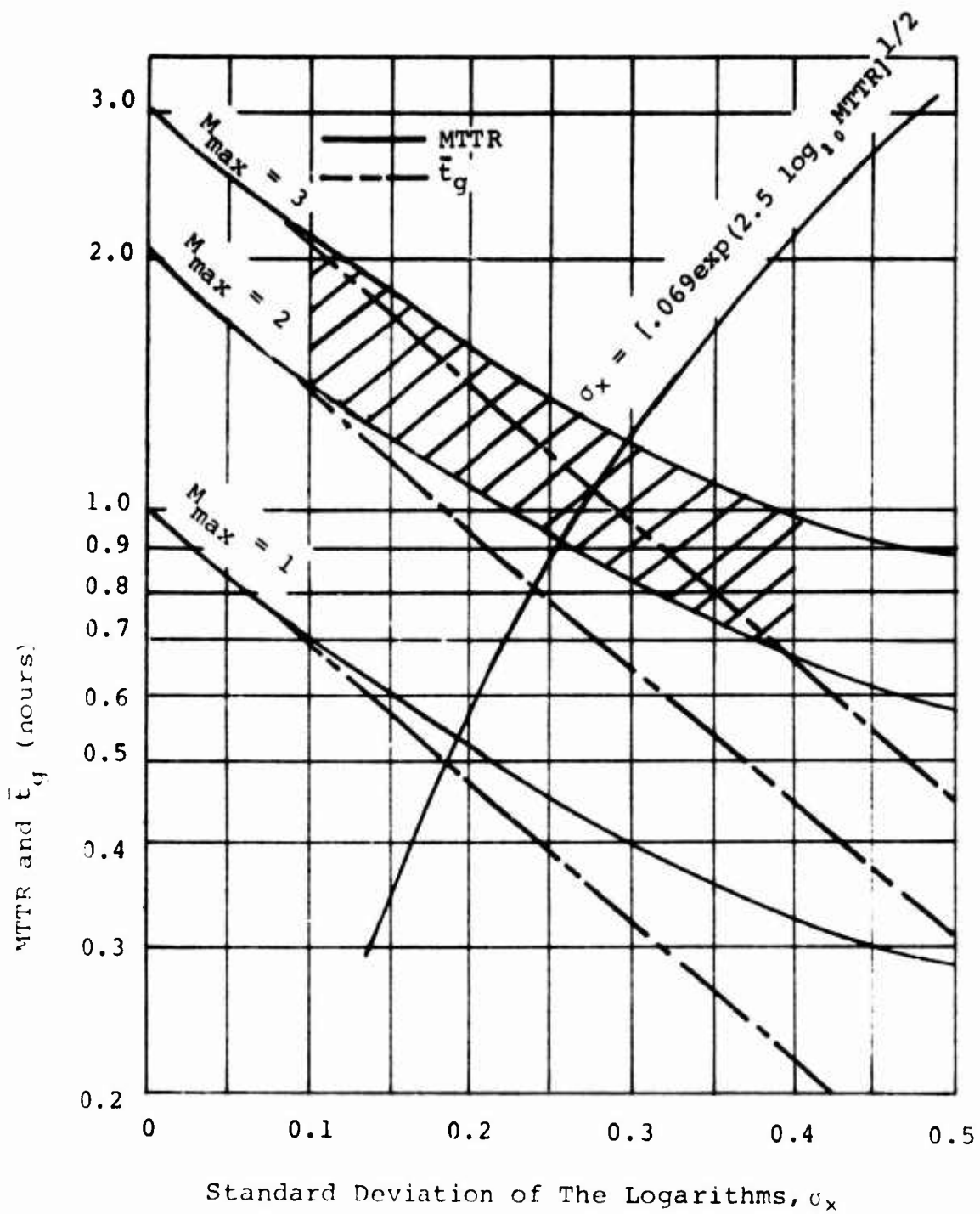

Figure 50. Maintainability Trade-offs.

As shown, the designer does have considerable latitude. He can design for more time-consuming repairs provided the repair techniques are such that they can be repeated with little variance from one occurrence to the next. Or, he must strive for a lower average repair time if the tasks are of a nature that produce wide fluctuations in performance time. It will be the function of the Maintainability Engineering group to work with the designer to achieve the best overall design within these constraints.

#### Reliability/Repair Time Trade-off

The 95th percentile repair time,  $M_{max}$  is the only quantitative expression of maintainability specified by the Army for the repairable/expendable blade. In terms of achieving this one goal, only two factors assume importance: the mix of repair tasks and their relative frequency. The absolute frequency of repair is not really pertinent since it is possible to obtain the same repair time distribution at entirely different levels of overall blade reliability. The reliability characteristics of the blade become important only insofar as they affect the distribution of tasks, i.e., make certain tasks occur more or less frequently in relation to the overall population of repair tasks. A reliability/repair time trade-off will be employed when the blade design characteristics are such that an involved repair task occurs too frequently. The decision here would be to increase the reliability (or reduce the vulnerability) of the blade in that area so as to reduce the frequency of this task or to design to make the task easier to perform. Overall reliability/maintainability relationships are of major importance, moreover, in the analysis of blade life-cycle costs.

MAINTAINABILITY ALLOCATION

BLADE CONFIGURATION:	DATE PREPARED:		REV:													
	DATE PREPARED:	REV:	DATE PREPARED:	REV:												
BLADE ELEMENT AND DAMAGE OR FAILURE DESCRIPTION	FMEA REF.	INHERENT	EXTERNAL	EVENTS PER 10 <sup>6</sup> FLT-HRS.	MAINTENANCE ACTION	LEVEL	ON A/C	OFF A/C	TIME-HOURS				NO. MEN	MAN-HRS. PER FLT-HRS. X 10 <sup>4</sup>	EQUIPMENT REFERENCE	REPAIR KIT REFERENCE
									REMOVE & INSTALL	REPAIR	TOTAL	95TH PERCENT. M <sup>max</sup>				
<u>SPAR</u>																
Abraded or Eroded		X		20	Blend/Refinish	ORG	X		1.2	1.2			1	.24		1
Nicked or Scratched			X	5	Restore Profile	ORG	X		0.8	0.8			1	.04		1
Dented			X	85	Restore Profile	ORG	X		0.8	0.8			1	.68		1
Worn		X		20	Blend/Refinish	ORG	X		1.2	1.2			1	.24		1
Abrasion Sheath Loose		X		10	Restore Bond.	ORG	X		1.5	1.5			1	.15		2
<u>SKIN AND CORE</u>																
Cracked		X		50	Patch	ORG	X		1.6	1.6			1	.80		3
Puncture thru one Surface Skin & Core			X	5	Patch	ORG	X		1.8	1.8			1	.09		3
Delamination Between Skin & Core		X		80	Patch	ORG	X		2.0	2.0			1	1.60		3
<b>TOTAL</b>				<b>275</b>												
<b>WT. AVG.</b>									<b>1.26</b>	<b>3.1</b>						<b>3.84</b>

Figure 51. Maintainability Allocation Data Format.

or failure will be apportioned to components of the blade based on the damage scenario and a preliminary engineering estimate of inherent failure rates. The nature of the anticipated damage or failure will be tentatively identified on the basis of the cause and the assumed blade construction in the affected area. These preliminary determinations will be subject to repeated modifications as the specific design characteristics of the blade evolve.

The estimated frequency of failure damage provides the basis for allocating repair time to discrete elements of the blade (spar, grip doublers, skin, core, etc.). An initial decision will be made in the case of each failure or damage incident to either scrap the blade or to provide for repair on or off the aircraft. In some cases, such as massive damage to the spar, the decision to scrap will be obvious. In others, an engineering analysis will be needed to assess the reliability, safety and economic implications of the contemplated repair. Such analysis will rely primarily on intuitive judgments in the early stages of the apportionment and gradually be refined as the design progresses.

For each damage or failure event scheduled for repair, a brief statement of the repair task is entered in the repair time allocation sheet. The appropriate maintenance level is assigned and a decision is made to effect the repair on the aircraft or to remove the blade for repair.

The next step in the allocation process is to assign a repair time goal to each repair task. When an off-aircraft repair has been established, the standard blade removal and installation time of 3.75 hours is assigned. The time to effect the repair is next allocated and, where an off-aircraft repair is being made, added to the blade replacement time to obtain the total task time allocation.

The repair time allocation reflects the initial engineering estimate of the elapsed time required for the typical Army mechanic to perform specified types of repairs on the blade. It encompasses the time required to isolate and correct the fault, including any adhesive cure time, and placing the aircraft in an operational readiness status. It attempts to reflect expected performance under field maintenance conditions and the resources available to the field mechanic. It is an estimate of productive maintenance time, however, and does not account for supply delays, administrative time, etc.

As mentioned earlier, the initial maintainability allocation will rely primarily on engineering judgment supported where

possible by historical precedent. The historical data base available for this task is described elsewhere in this plan.

After repair times have been allocated to each repair task, the mean-time-to-repair for the entire blade is calculated using the frequency of occurrence as the weighting factor. The 95th percentile repair time ( $M_{\max}$ ) for the overall blade is calculated next using the regression equation defined earlier. If the value of  $M_{\max}$  exceeds the 3.0 hours specified, the repair time goals must be tightened. The analyst will review the distribution of repair tasks and allocated goals and reduce repair times on those tasks for which a more stringent specification can most easily be attained. After these adjustments have been completed,  $M_{\max}$  for the overall blade is again calculated and compared with the 3.0 hour specification. If necessary, another iteration will be made to bring the allocations within specification. It may be that no combination of feasible repair time goals will satisfy the requirement. This indicates that the basic design concept may require modification and a resolution of problem areas must be pursued with the designer.

The next step in the allocation procedure is a definition of the support equipment and repair materials which the maintainability engineer specifies for the task. A certain bond restoration task may, for example, be limited to a cold patch using a simple pressure pad secured to the blade with bungee cord. These specifications will of course require considerable interchange and trade-off between the designer and the maintainability engineer.

When completed, the maintainability allocation becomes a design specification against which progress is measured. Deviations from the allocated repair time goals and resources will be resolved on an individual basis as they occur. This will insure that the design does not reach an unacceptable maintainability characteristic too late to easily effect remedies.

#### Application of Historical Data

There are several sources of historical data on helicopter rotor blades which can be drawn upon for this program. Data of this type will be particularly important during the maintainability allocation task when engineering judgment and historical precedent form the basis for developing design goals.

## ANALYSIS AND PREDICTION

Analysis and prediction of maintainability will be a continuation of the allocation process. The maintainability allocation described earlier becomes integrated into the design for the rotor blade early in Phase I and comprises the baseline for maintainability predictions. Maintainability analysis and prediction is an iterative process of upgrading and refining the original allocation as new design information becomes available in the later stages of Phase I.

A maintainability prediction will be performed for each of the candidate rotor blade design concepts. The prediction will be carried out using MIL-HDBK-472, Procedure II, Parts A and B, modified by the treatment of repair time variance discussed under Maintainability Indices. The contractor has developed a computer program for conducting the maintainability predictions as part of the life-cycle cost analysis. Using individual task times and frequencies as the basic input and the techniques discussed earlier for predicting the repair time distribution, the computer program calculates the following maintainability indices by component, subsystem and level of maintenance:

- Mean-Time-To-Repair (MTTR)
- Mean Preventive Action Time ( $\bar{M}_{pt}$ ).
- Mean Active Corrective and Preventive Action Time ( $\bar{M}$ ).
- Maintenance Man-Hours Per Flight-Hour (MMH/FH).
- Maximum Corrective Maintenance Time ( $M_{max}$ ) - (subsystem level only).

Use of this program facilitates the maintainability prediction task and permits the impact of changes in maintenance functions, failure rates, task time, etc. to be analyzed easily.

The maintainability predictions will parallel the allocation techniques described earlier and will use the same format (Figure 51) for documenting the results. Reference to the Failure Modes and Effects Analysis (FMEA) will be introduced at this point to relate repair tasks to the specific failure modes and causes for repair. Maintenance frequency and repair time estimates initially established for each concept during the maintainability allocation will be updated on the basis of the FMEA output and a maintenance task analysis of

each design concept. The prediction of repair time variance will use the regression equation described earlier except in cases where the analyst concludes that a smaller or larger value for the variance can be predicted for certain tasks.

An analysis and prediction of preventive maintenance requirements will also be performed in Phase I to establish the frequency and time requirements for scheduled maintenance tasks. This, together with the maintainability prediction for corrective maintenance tasks, will be used to calculate specified maintainability indices for the blade concept. The results of the maintainability allocations, analysis and predictions will be documented in the Phase I Report.

## MAINTENANCE REQUIREMENTS ANALYSIS

An analysis of maintenance requirements will be carried out as part of the Phase II Detail Design. This analysis will entail a definition of the basic maintenance functions and support requirements for the rotor blade. It will also include development of criteria for support equipment and personnel training based on the plan for maintenance.

The maintenance requirements analysis will involve three stages of development:

1. Preparation of a maintenance plan for each of the major blade elements to include identification of all preventive and corrective maintenance functions and the rationale, where pertinent, for the selected maintenance concept.
2. Identification of the basic support requirements for each of the preventive and corrective maintenance functions to include personnel skill, task time, special tools and support equipment.
3. Detailed task descriptions and illustrations for each of the defined maintenance functions to be assembled into a maintenance instruction manual for the rotor blade.

Figure 52 shows the format in which the maintenance concept and plan will be documented. In each block of the form is contained a description of the data to be recorded there. Figure 53 is the format to be used for documenting the maintenance requirements applicable to each of the preventive and corrective maintenance functions. Detailed task descriptions and instructions will be prepared in technical manual form.

MAINTENANCE PLAN	
BLADE ELEMENT:	PART NUMBER:
DESIGN DESCRIPTION:	<p>This block shall present the blade element design in sufficient detail to identify repairable items, configuration, construction, and features. Areas of the design that impact the maintenance plan shall be specifically identified.</p>
MAINTENANCE PLAN:	<p>This block shall contain a concise narrative of significant planned maintenance actions essential to the formulation of a sound maintenance plan. It will list terse basic functions necessary to maintain the rotor blade. Typical of those areas which will control the type of maintenance performed are unusual depth or frequency of maintenance, unique manpower skills, new requirements for facilities or equipment, limiting technical factors such as service life, retirement life and Mean-Time-To-Repair.</p>
PLAN RATIONALE:	<p>This block shall contain statements of the reasoning in support of the plan. The plan must be supported by a credible documented analysis which considers experience on similar items and pertinent characteristics of the design.</p>

Figure 52. Maintenance Plan Format.

MAINTENANCE REQUIREMENTS						
Blade Element:		Part Number:				
Req. No.	Requirement	Technical Justification	Level	Mos	Task Time	Support Equipment
R-01	Daily Inspection. External visual inspection for nicks, scratches, dents, holes and cracks. Check security of blade attachment. Inspect grip plates and doublers for bond separation.	To insure blade integrity.	Org.	67N20	8	Maintenance check stand.
R-02	Conditional Inspection. Inspect blade following a main rotor overspeed or hard landing to ascertain that no structural damage, distortion or bond separation has occurred. Give particular attention to the retention bolt hole and drag brace hole.	To insure blade integrity.	Org.	67N20	12	Maintenance check stand. Standard hand tools.

Figure 53. Maintenance Requirements Data Format.

## DEVELOPMENT OF REPAIR KITS, PROCEDURES AND TOOLS

The development of repair kits and support equipment for the repairable/expendable blade will draw on the contractor's extensive rotor blade overhaul and repair experience. Over the years, the contractor has done extensive research and development in rotor blade repair techniques. Recently, in the course of two USAAMRDL funded studies, the contractor devised several standard repair kits for use in field repair concepts. Figures 54 and 55 show typical kit contents and frequencies of use which resulted from the studies. Figure 56 shows a typical listing of equipment requirements.

In the proposed program, blade repair kits and special tools will be developed and tested. In this task, the contractor will team with a leading developer and supplier of repair kits to commercial airlines. This subcontractor specializes in repair of composite bonded structures and will supplement and enhance the contractor's own capabilities in this area.

Objectives of the repair kits and special tool development effort will be to:

- Design repair kits and special tools suitable for the skill level of a UH-1 helicopter repairman, MOS 67N20.
- Keep the number of special tools to a minimum.
- Specify the minimum number of kit types, consistent with optimum repairability requirements.
- Select adhesives, fillers, etc. which will permit completion of repairs within the specified maximum active corrective maintenance time.

Concepts for repair kits and special tools will be developed initially during Phase I resulting in preliminary concept drawings and fabrication procedures. In Phase II detail design of repair kits and tools for the selected design concept will be undertaken. Detailed repair procedures will also be developed during Phase II and assembled into a Manual of Repair Instructions. This manual will be submitted as part of the Maintainability Demonstration Plan to be developed in Phase III.

**REPAIR KIT CONTENTS**

ITEM NO.	ITEM	DESCRIPTION	-1- EXPOSED METAL KIT	-2- ABRASION SHEATH KIT	-3- DIRECTED GLASSFIBER KIT	-4- SKIN PATCH KIT	-5- PLUG/ PATCH KIT	-6- I.E. DOUBLER KIT
1	Sand Paper	Sheet, 9 in. sq., 180 grit	2	4	4	2	2	2
2	Sand Paper	Sheet, 9 in. sq., 240 grit	2	4	4	8	4	8
3	Sanding Disc	1 1/2 in. dia. (used with air meter)		2	4	2	2	2
4	Cheese Cloth	18 in. wide, (qty. indicated in ft.)	10	20	8	16	20	18
5	Mck Solvent	Pint Can	1	1	1	1	1	1
6	Adhesive Stripper			1				
7	Cotton Gloves	Pair, Light Weight		1	1	1	1	1
8	Rubber Gloves	Pair, Chemical Resistant		1				
9	Mixing Cup	Quart Size, Paper	2	4	2	3	2	3
10	Wooden Spatula	Tongue Depressor	1	2	1	2	1	2
11	Serrated Spreader	Contractor made		1	1	1	1	1
12	Masking Tape	Roll, 1 in. wide	1	1	1	1	1	1
13	Hi-Temp. Mylar Tape	2 in. wide, (qty. indicated in ft.)	1	10	5	5	10	5
14	Aluminum Tape	1 in. wide, (qty. indicated in ft.)		15				
15	Teflon Film	Sheet, transparent, .0005x20x40 in.		2	1	1	2	1
16	Aluminum Sheet	Sheet, .010 x 20 in. square	1	1	1	1	2	1
17	Brush	1/4 in. wide		1	1	1	1	1
18	Brush	2 in. wide		1	1	1	1	1
19	Iodine, Brushable	1 oz. bottle	1	2	1	1	1	1
20	Zinc Chromate Primer	3 oz. aerosol can	1	1	1	1	1	1
21	Paint, Brown	3 oz. aerosol can	1	1	1	1	1	1
22	Paint, Black	3 oz. aerosol can	1	1	1	1	1	1
23	Wrap-Around Template	Contractor made		1				
24	Preimpregnated Skin	Sheet, 4 ply, 120 cloth, 8 x 16 in.				1		
25	Plug/Patch & Frame Doubler	Contractor made						
26	Trailing Edge Doubler	Contractor made						
27	Abrasion Sheath Segment	Contractor made		1				1
28	Directed Glass Fiber Material	Sheet, 1/8 thick x 8 wide x 4 in. long			1			
	Adhesive EC 2216	Special 2 section plastic package	1	2	1	1	2	1
	Corfil 615	Special 2 section plastic package				1		1
	Lead/Epoxy Filler	Special 2 section plastic package		1				

Note: The last three items are required as indicated, but not included in kits due to limited shelf life.

Figure 54. Sample Repair Kit Contents.

REPAIR KIT USE FREQUENCIES				
Kit No. and Type	Configuration I	Configuration II	Configuration III	Configuration IV
1. Exposed Metal Repair Kit	3	2	9	0
2. Abrasion Sheat Kit	1	1	1	13
3. Directed Glass Fiber Repair Kit	6	0	7	14
4. Skin Patch Kit	13	16	15	17
5. Plug/Patch Kit	22	23	20	20
6. Tralling Edge Doubler Kit	9	8	7	7

Figure 55. Sample Repair Kit Use Frequencies.

EQUIPMENT LIST									
ITEM NO.	DESCRIPTION	EQUIPMENT REQUIREMENTS						-6- T.E. DOUBLER REPAIR	
		-1- EXPOSED METAL REPAIR	-2- ABRASION DIRECTED SHEATH REPAIR	-3- GLASS FIBER	-4- SKIN PATCH REPAIR	-5- PLUG/ PATCH REPAIR			
1	Heating Blanket (12 in. x 12 in.)		3	1	1	1	2	1	
2	Inflatable Bladder with Straps		3	1	1	1	1	1	
3	Tire Hand Pump (or compressed air)		1	1	1	1	1	1	
4	Tire Pressure Gage		1	1	1	1	1	1	
5	Scissors					1			
6	28 Volt D.C. Power Source		1	1	1	1	1	1	
7	Scraping Knife		1			1	1	1	
8	Die File	1							
9	Electric Heat Gun		1						
10	Hack Saw						1		
11	4 in. Long Knife							1	

Figure 56. Sample Equipment List.

Kits and tools will be fabricated during Phase III and evaluated as part of the maintainability demonstration in Phase III and the repair-and-fly segment of the flight test program in Phase IV.

Each kit and special tool will be thoroughly evaluated during the maintainability demonstration. This evaluation will include considerations such as the following:

- Is the level of prefabrication of patches, plugs, etc., optimum? Is the selection of patch size adequate?
- Is the supply of consumables such as abrasive paper, solvent, etc., adequate?
- Are the selected chemical cleaners and solvents effective?
- How convenient is the prescribed method of mixing 2-parts adhesives?
- Is the pot life of the adhesive sufficiently long to permit ample application time?
- Do the kits contain adequate safety apparel or devices?
- How convenient will their use be under adverse field conditions? Also do special heat sources used create fairly constant temperatures within acceptable limits?

The subcontractor will assist in the demonstration and evaluation of the repair kits and tools. The results of this evaluation will be documented in the Phase III Report and Final Report.

## MAINTAINABILITY DEMONSTRATION

A maintainability demonstration will be conducted at the conclusion of the repair-and-whirl phase of the whirl test program in Phase III. A formal maintainability demonstration plan, prepared in accordance with MIL-STD-471, will be submitted 45 days prior to the start of the demonstration. The following paragraphs outline briefly the scope and objectives of the maintainability demonstration.

The maintainability demonstration will be performed using Army UH-1 helicopter repairmen, MOS 67N20, and the approved repair kits, support equipment and repair procedures. The Army will be asked to supply two general helicopter repairmen for approximately two weeks. The Army maintenance personnel, after a basic familiarization with the rotor blade and repair procedures, will be required to perform a number of representative repairs using the repair kits, support equipment and repair instructions previously developed. Careful attention will be given to selection of the tasks to be demonstrated to insure that each of the different tasks is demonstrated at least once and that the overall demonstration is, insofar as possible, representative of the kinds of repairs expected in the field. Criteria to be considered in selection of the task sample will include the type, location and severity of failure or damage. Approximately twenty tasks will be demonstrated.

Contractor and Government personnel will witness the maintainability demonstration. The adequacy of the repair kits, support equipment and repair instructions will be carefully monitored and evaluated. Deficiencies observed in any of these areas will be recorded for analysis and resolution at the conclusion of the demonstration.

The time required to perform the various repairs will also be monitored and recorded. Each task will be documented in terms of the time required to isolate a fault, repair, test, etc. The task time data recorded during the demonstration will be compared with the maintainability predictions to verify or modify the analytical projections. Because the data base necessarily will be small in terms of statistical confidence, it may be necessary to apply some measure of engineering judgement to the demonstration results.

It also will be necessary to perform repairs of the rotor blade during the flight test program to evaluate the effect of certain repairs on blade strength characteristics, flying qualities, etc.

Data collected during the flight-tests will be used to supplement the formal demonstration.

The maintainability demonstration plan will be prepared and submitted for approval of the Contracting Officer. The plan will provide a detailed schedule for the demonstration including identification of the specific tasks to be demonstrated. It will also include a detailed description of the repair kits and equipment to be used and the specific conditions under which the demonstration will be conducted. The repair instructions will be submitted as part of the demonstration plan.

## SCHEDULE OF TASKS

The maintainability program for the repairable/expendable rotor blade will encompass the following tasks: Figure 57 shows the schedule of tasks.

### 1.0 Phase I - Preliminary Design

- 1.1 Allocation of maintenance frequency and repair time goals for each of the candidate design concepts.
- 1.2 Definition of basic maintenance functions and support requirements for each of the candidate design concepts.
- 1.3 Incorporation of maintainability requirements into the blade design specifications.
- 1.4 Preparation of preliminary design drawings for repair kits.
- 1.5 Development of preliminary fabrication procedures for repair kits.
- 1.6 Analyses of repairs designated for each of the proposed repair kits.
- 1.7 Prediction of the Mean-Time-Between-Maintenance, MTBM (Scheduled and Unscheduled) for each rotor blade concept using the results of the Failure Modes and Effects Analyses.
- 1.8 Prediction of the Mean-Time-Between-Removal, MTBR for each rotor blade concept broken down into maintenance function and cause categories.
- 1.9 Maintainability prediction for each blade concept to include the following maintainability indices:

Mean-Time-To-Repair, MTTR

Mean Preventive Action Time,  $\bar{M}_{pt}$

Mean Active System Downtime,  $\bar{M}$

Maximum Corrective Maintenance Time,  $M_{max}$

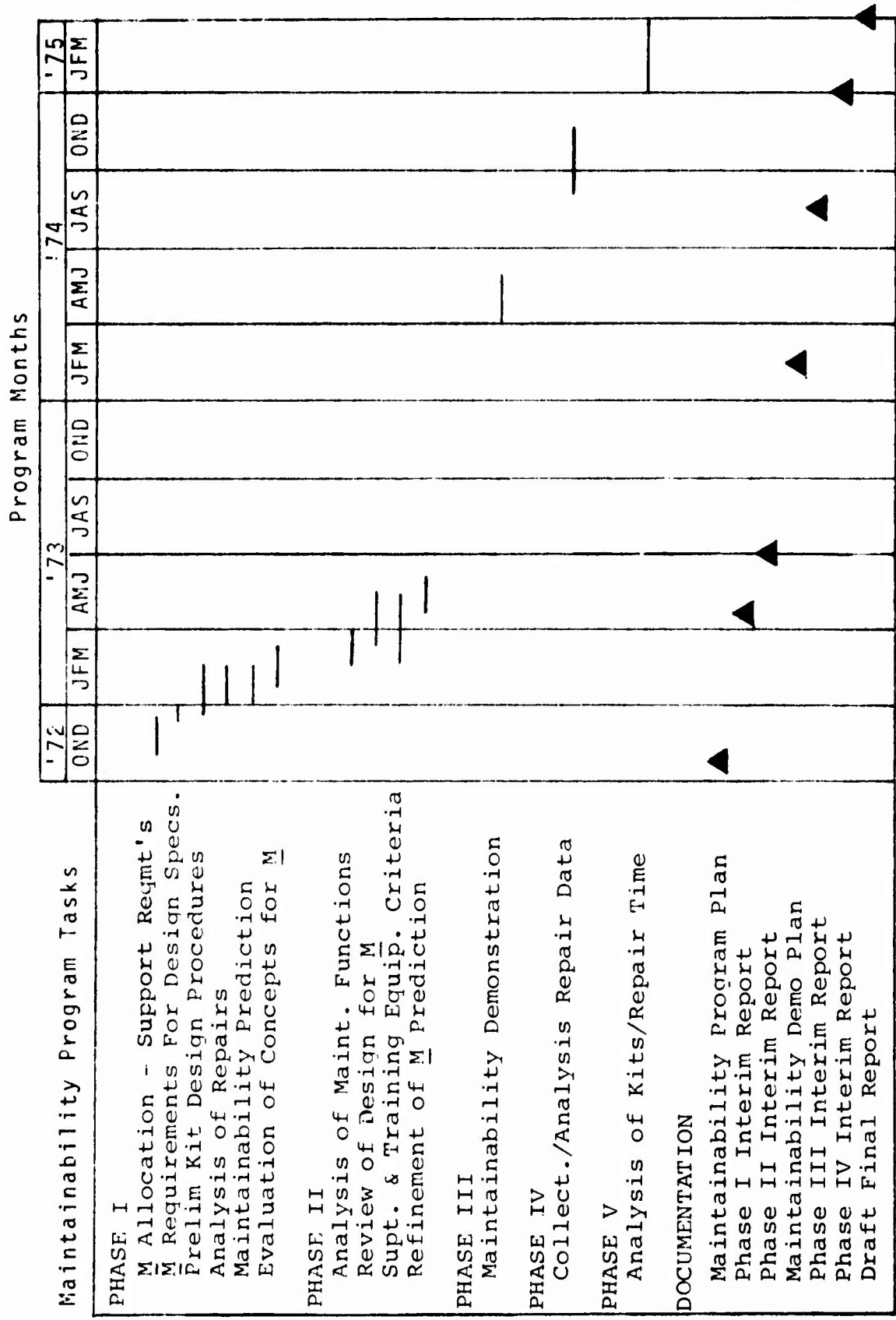

Figure 57. Maintainability Program Schedule.

## Maintenance Man-Hours Per Flight-Hour, MMH/FH

### Maintenance Personnel Requirements

- 1.10 Participation in the analytical comparison of blade design concepts.
- 1.11 Presentation of repair kit designs for approval of the Contracting Officer.
- 1.12 Contribution to the Phase I Report.
- 2.0 Phase II - Detail Design
  - 2.1 Analysis of all maintenance functions and support requirements.
  - 2.2 Review of design adequacy for maintainability prior to final detail design.
  - 2.3 Development of criteria for support and training equipment.
  - 2.4 Review and refinement of the Phase I Maintainability Analysis and Prediction.
  - 2.5 Contribution to the Phase II Report.
- 3.0 Phase III - Whirl Tower Tests
  - 3.1 Preparation and submittal of a Maintainability Demonstration Plan.
  - 3.2 Maintainability demonstration conducted with Army personnel at the conclusion of the whirl test program.
  - 3.3 Contribution to the Phase III Report
- 4.0 Phase IV - Flight Demonstration
  - 4.1 Collection and analysis of repair data resulting from the repair-and-fly phase of the flight test program.
  - 4.2 Contribution to the Phase IV Report
- 5.0 Phase V - Engineering Analysis

- 5.1 Analysis of repair kit maintainability and repair time requirements
- 5.2 Contribution to the Final Report to include the results of the maintainability demonstration conducted in Phase III

## APPENDIX IV

### RCS EVALUATION OF REPAIRABLE/EXPENDABLE MAIN ROTOR BLADE CONCEPTS

#### EVALUATION

##### Introduction

The purpose of the study is to relate RCS values of Concepts 1, 2, and 3, to the RCS of the UH-1H metal blade. Theoretical and measured data are utilized to provide an estimate for the four designs. The measured data was obtained by testing conducted on Design 2, Reference 3, in accordance with an earlier contract, classified CONFIDENTIAL. During that contract, a blade diagnostic section was modeled to the dimensions of the UH-1H blade, and features of Design 2, Reference 3, were incorporated as required. Those results are used in this report to establish measured RCS levels of the designs using fiberglass materials. A final model provided the RCS of the Design 2, Reference 3, blade section, metallized and with the final RAM configuration applied. Absolute levels of RCS are not included here, in order to avoid compromising classified data.

The prime scatterer is identified for a metal blade. Delta RCS values are established and presented in graphical form to depict RCS changes caused by design technique and dimension changes. This method is also utilized to establish the relative importance of the scatterers.

##### Discussion

The main rotor blade has peak RCS returns for the leading edge (LE), trailing edge (TE), and each tip. Previous measurement programs have identified these peak values for several frequencies. The median RCS values for any part of the blade are not considered significant when considered in relation to RCS values associated with the helicopter main body. A theoretical investigation relating the importance of the blade peak returns to the body returns has been conducted. It is believed that the blade peak RCS becomes significant when a value of, or in excess of, 12 dB greater than median body return is reached. One must know the body and blade RCS level for a specific application to establish critical blade peak values. It could be suggested that an untreated helicopter body would be large enough to render a metal blade RCS peak value insignificant. RCS treatment of the body could expose the largest peak returns from the blade. It is

known that the leading-edge return of a metal blade is usually several dB larger than the trailing-edge return (see Figure 58). Generally speaking, if the leading-edge RCS is not reduced, the trailing-edge return is insignificant. Likewise, the RCS return from blade tips is insignificant. Any significant RCS return from the blade tip areas (90 degrees and 270 degrees) is largely due to the rotor attachment and positioning mechanism and to the blade doublers. Ideally, all RCS returns from the secondary contributors should be 3 dB or more below the value of the largest contributor (generally the leading edge).

All measurements to date, for which data are available, have been static measurements. Under dynamic operating conditions the rotating blade experiences in-plane bending. Theoretical RCS prediction of the peak values (leading edge) is possible. A table depicting these theoretical values is presented later in the text. Assumptions made for the calculations are that all four designs have the same in-plane bending (1.04 degrees) and that the bending is uniform from root to tip. In-plane bending of 0.69 degree is used for the metal UH-1H blade.

Concepts 1, 2, 3, and 4 are very similar from the RCS standpoint to the Design 2 blade measured under the earlier contract. Concepts 2 and 4 have the same exterior dimensions as the UH-1H blade. Concepts 1 and 3 airfoil is changed such that the nose has a larger radius and the trailing-edge wedge is slightly decreased in size.

Internally, Concepts 1 and 3 use an aluminum alloy main spar while Concepts 3 and 4 use a stainless-steel spar. For RCS considerations it is immaterial which spar is used. Concepts 1 and 2 use an aluminum alloy trailing-edge spline, while Concepts 3 and 4 utilize a fiberglass spline. If the trailing edge is metallized, there would be no difference electrically between the designs due to the splines. If the treated core is considered, Concepts 3 and 4 would be preferred, though the differences due to the spline electrically would likely be insignificant.

During the earlier measurement program, the final model was fabricated to the dimensions of Reference 3, Design 2. The "diagnostic" model was fabricated to the dimensions of the UH-1H blade. The RCS value differences obtained from measurement of the metallized models were insignificant except at X-band, where leading-edge RCS values were increased by 2 to 5 dB at perpendicular polarization.

Figure 59 depicts the increase in trailing-edge return

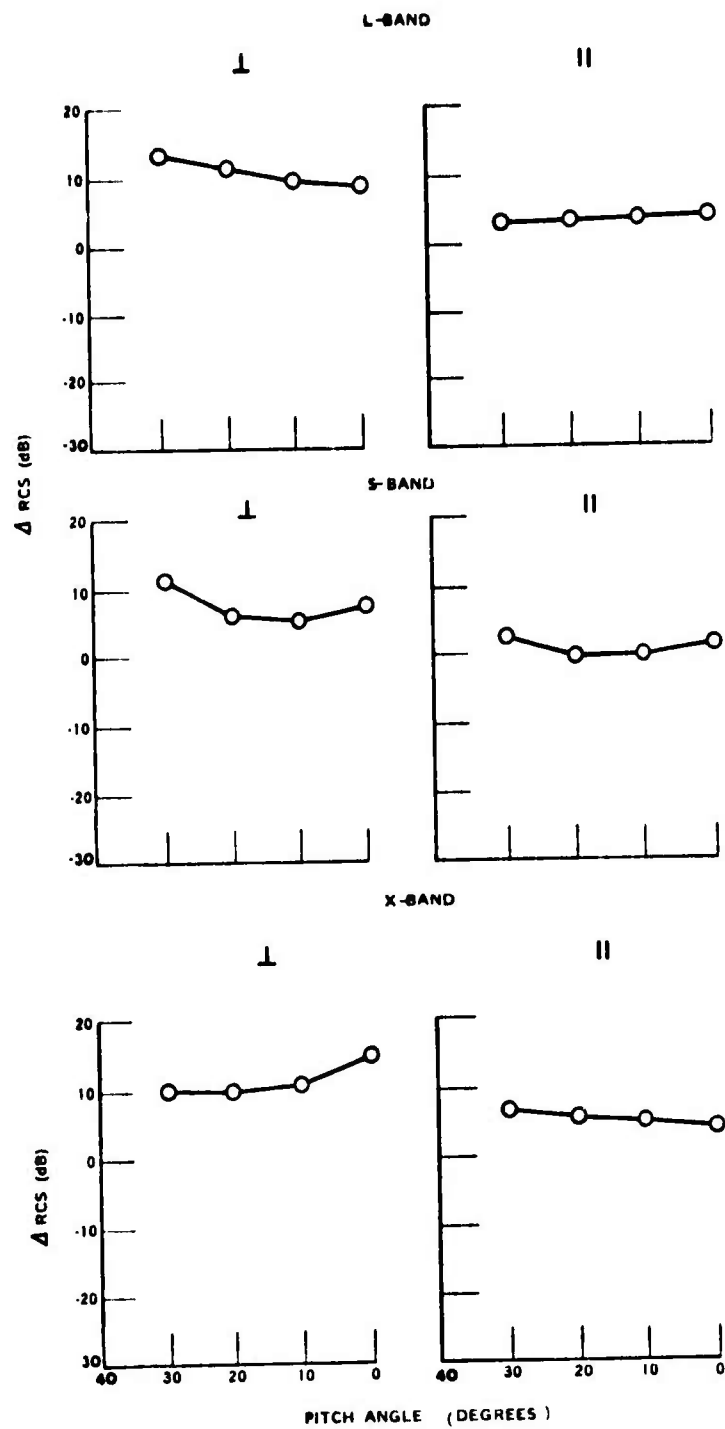

Figure 58.  $\Delta$ LE Vs TE - UH-1H Metal  
LE >+.

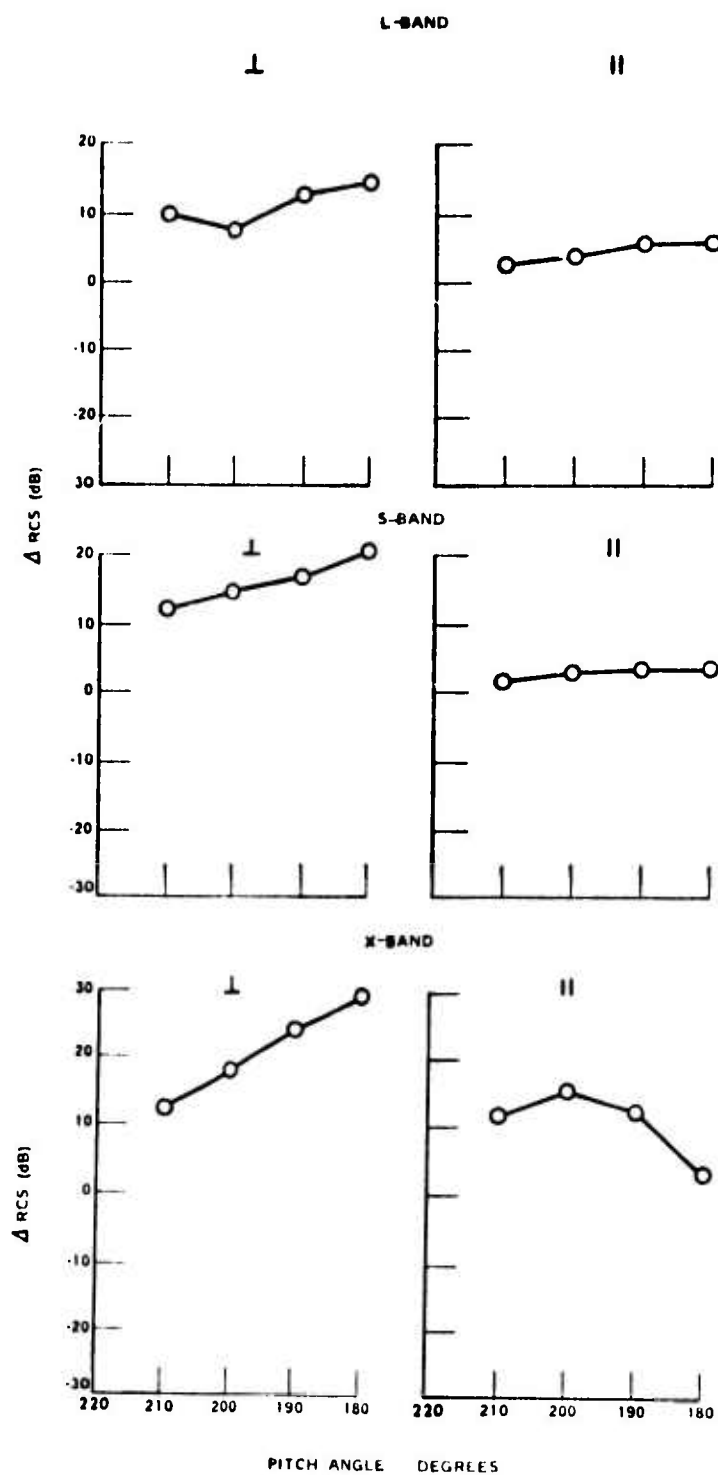

Figure 59. Design 2 (Reference 3) Metallized Vs Design 2 Fiberglass Trailing Edge Comparison, Design 2 Fiberglass >+.

caused by exposure of the flat-backed metal spar to the radar by the fiberglass materials. RCS increases of from 1 to 29 dB are shown for various pitch angles, frequencies, and polarizations. Since the trailing-edge RCS return is important primarily in relation to the RCS magnitude of the leading edge, a comparison of leading-edge return vs. Design 2 (Reference 3) trailing-edge return is provided by Figure 60. Trailing-edge return is increased above the leading-edge return for nearly every aspect angle, frequency, and polarization. It is concluded that the trailing-edge return must be reduced. Reduction techniques are discussed later in this appendix. Basically two methods are considered: treat the trailing-edge honeycomb core with carbon to absorb the radar energy, or metallize the trailing edge to reflect the radar energy away from the receiver. Figure 61 shows the results of the carbon-loaded core trailing-edge returns compared to the diagnostic model leading-edge returns. The trailing-edge returns are significantly below the leading-edge returns for every polarization and frequency except S-band perpendicular polarization. The carbon-loaded core treated trailing edge shows lower RCS values when compared to the metallized trailing edge for nearly every frequency, polarization and aspect angle.

Figure 62 shows the leading-edge RCS peak value increase due to larger radius as measured.

Table XXI is provided for a summary of comparisons of the factors affecting the leading-edge 0-degree pitch aspect angle peak RCS return. Table XXI consists of measured and theoretical data for the static condition and theoretical data only for the dynamic condition. The theoretical RCS value of the UH-1H blade at X-band and static condition is used as the reference and compared to all other values. Study of Table XXI shows excellent correlation of theoretical and measured values except for the smaller radius blade ( $r_1$ ) at X- and S-bands, where differences of 3.1 and 2.6 dB respectively are observed. The theoretical increase in RCS due to the increased nose radius ( $r_2$ ) is 1.0 dB. Dynamic RCS is decreased by 1.8 dB for Concepts 1, 2, 3, and 4 when compared to the UH-1H blade by the in-plane bending. Concepts 1 and 3 net a theoretical reduction of 0.8 dB even with the increased nose radius. Figure 63 is a graphical illustration of data presented in Table XXI.

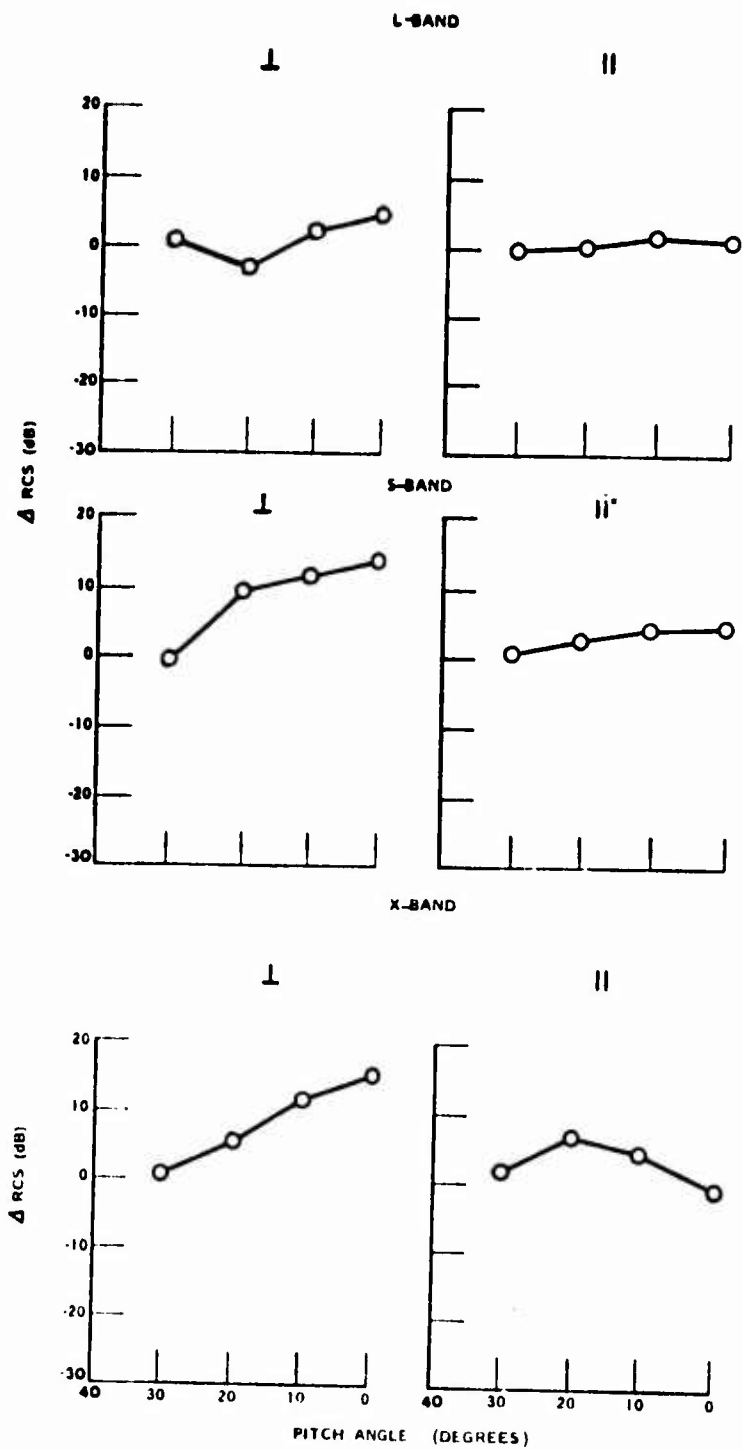

Figure 60. Design 2 (Reference 3) TE Vs LE - UH-1H  
TE > +.

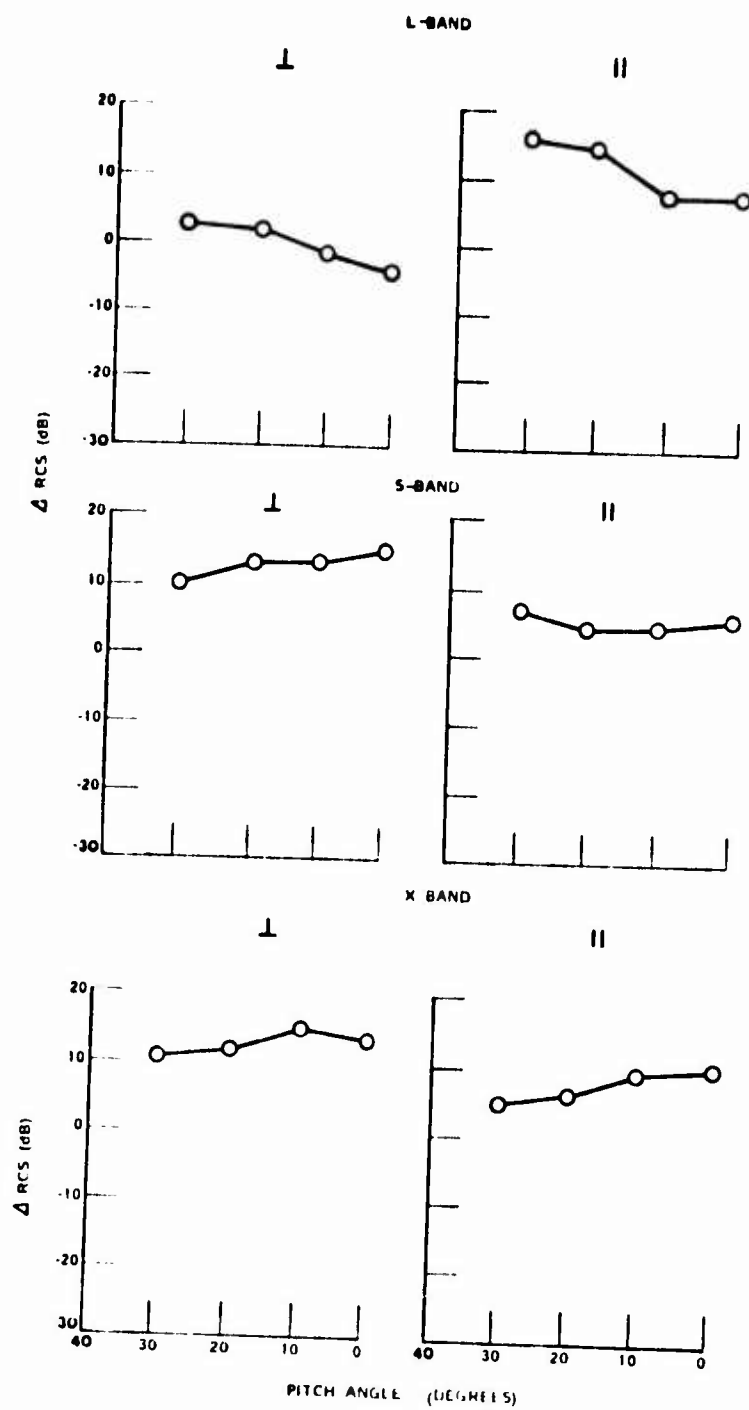

Figure 61. Carbon Loaded Core TE Vs LE, Design 2 (Reference 3), LE >+.

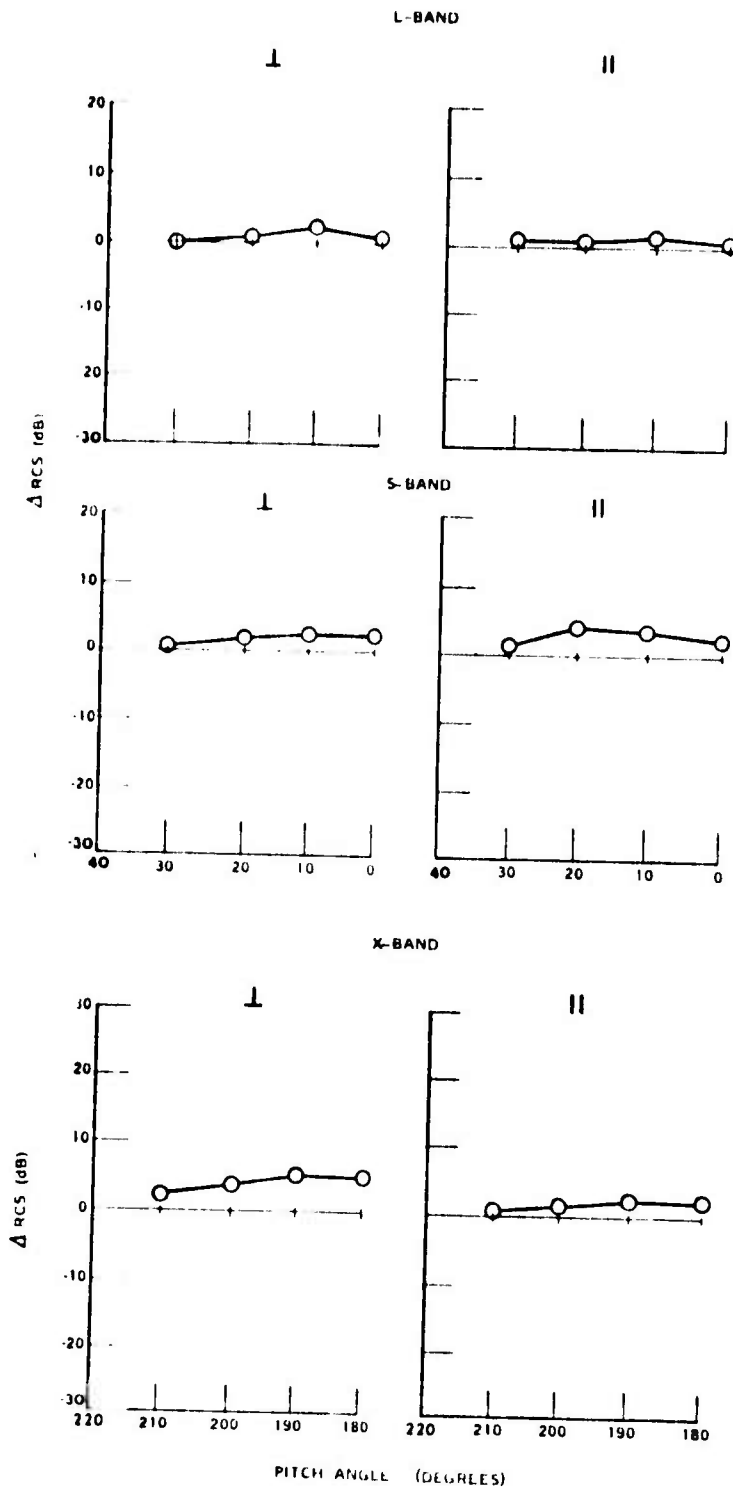

Figure 62. LE Peak Value  $\Delta$  Due to Increased Radius

TABLE XXI. LEADING-EDGE 0-DEGREE PITCH ASPECT ANGLE  
PEAK VALUE RCS COMPARISON (dB)

Operating Conditions	Frequency	UH-1H (r1)		Concept 2, 4 (r1)		Concept 1, 3 (r2)	
		Theoretical	Measured*	Theoretical	Measured*	Theoretical	Measured*
Static	L	X-8.5	X-8.4	X-6.5	X-8.4	X-7.5	X-7.6
	S	X-5.2	X-7.8	X-5.2	X-7.8	X-4.2	X-4.6
	X	X	X-5.1	X	X-3.1	X+1.0	X+1.6
Dynamic	L	X-7.3	---	X-9.1	---	X-8.1	---
	S	X-7.3	---	X-9.1	---	X-8.1	---
	X	X-7.3	---	X-9.1	---	X-8.1	---

\*Parallel, Perpendicular Polarization RCS Average

	T	THEORETICAL UH-1H	
STATIC	M	MEASURED UH-1H	
	13T	CONCEPT 1, 3, THEORETICAL	
	13M	CONCEPT 1, 3, MEASURED	
DYNAMIC	H	UH1-H	} THEORETICAL
	24	CONCEPT 2, 4	
	13	CONCEPT 1, 3	

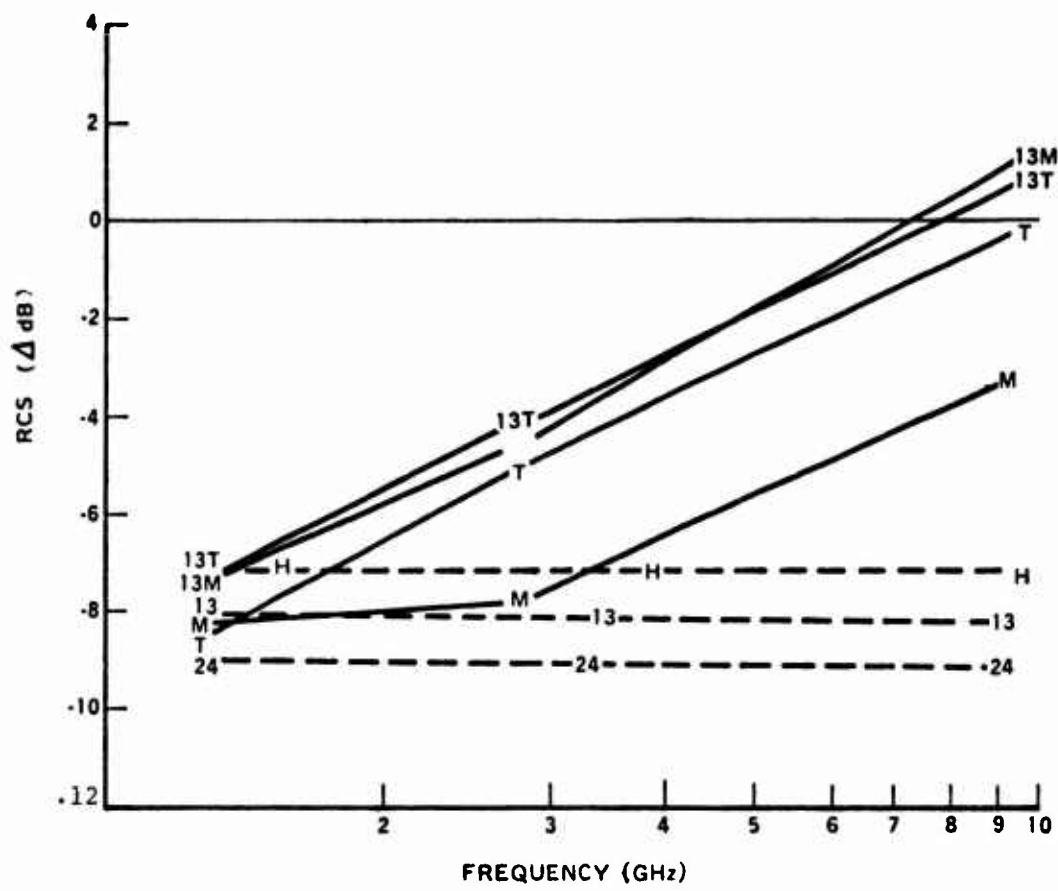

Figure 63. Leading-Edge 0-Degree Pitch Aspect Angle Peak Value Comparison.

## Conclusions

1. All four fiberglass designs expose the flat-backed metal spar and cause trailing-edge RCS increases above that of the UH-1H reference level. Trailing-edge treatment must be accomplished to prevent the trailing-edge RCS from becoming the prime contributor for the four fiberglass designs.
2. Treatment of the blade trailing edge can be accomplished by two basic methods: absorb the radar energy, or reflect the energy away from the threat receiver. Absorption of the energy has some benefits not provided by the second method. Lower trailing-edge RCS is experienced, multi-bounce reflections are minimized, and bistatic radar threat is reduced.
3. The increased leading-edge radius of Concepts 1 and 3 causes an increased leading-edge RCS; however, due to the increase of in-plane bending of the fiberglass designs, the peak RCS value is no greater than that of the reference blade. Concepts 2 and 4 have a lower RCS peak value than the reference blade due to the in-plane bending.
4. All four designs will meet the requirements that RCS values be no greater than that of the UH-1H metal blade if the trailing edge is treated.

## TRAILING-EDGE REDUCTION TECHNIQUES

### Introduction

Two basic methods are available to reduce the trailing-edge RCS level. Absorb the energy or deflect it away from the threat radar. Energy deflection can be accomplished by metallizing the aft section of the trailing-edge return to the reference level set by the UH-1H metal blade. Absorption of the energy would reduce the peak values to an average (3 frequencies, 2 polarizations) approximate level of 7 dB below the reference level.

### Discussion

Several techniques are available to metallize the blade trailing-edge surface. Conducting paints or lacquers and sheet conductors are considered the most logical choices. Sheet conductors are metal foils or screens. The sheet conductors require bonding resins for part fabrication. The foil would require two resin layers while the screen would probably require only one resin layer. The resin weight is estimated to be 0.04 pound per square foot. Ground planes have been made utilizing 0.002-inch aluminum and 16- to 20-gauge aluminum screen using

two resin layers. Aluminum films are available as thin as 0.00025 inch with a weight of 0.0035 pound per square foot. It is likely that lighter weight aluminum screen is also available. The following data is supplied as a weight estimate per square foot for metallizing the rotor blade aft section.

<u>System</u>	<u>Weight (lb/ft<sup>2</sup>)</u>
Screen Wire (18 gauge nominal, 2 resin layers)	0.120
(1 resin layer)	0.080
Aluminum Foil (0.002 inch, 2 resin layers)	0.109
(0.00025 inch, 2 resin layers)	0.084
Epoxy Base Aluminum Paint	0.111
Silver Lacquer	0.025
Metal Lacquer	0.019

The metal lacquer appears to have a weight advantage based on sales data.

Conductive paint candidates are copper, aluminum, or noble metal in an epoxy resin bonding system. Due to weight and cost advantages, aluminum is the most likely candidate. Abrasion, adhesion, and electrical resistance should be verified to be system compatible.

Aluminum in an epoxy resin bonding system will have the following properties:

Electrical Resistance	0.4 to 20 ohms per square
Surface Adhesion	Excellent
Abrasion Resistance	Good
Chemical Resistance	Good
Solvent Resistance	Excellent
Cure Temperature	175°C -- 1 Hour
Max. Service Temp.	325°C

The problems to be expected with conductive paints are that, with anything other than silver, an electrical resistance of less than 10 ohms per square is difficult to achieve and processing steps to obtain the excellent surface adhesion include surface preparation and surface prime. The conductivity of the chosen system is estimated to require a value of less than 20 ohms per square to maintain an adequate state of metallization. The smaller the ohms per square value, the better the radar reflective surface becomes.

Additional paints that should be investigated are a silver lacquer and a metal lacquer that are available commercially. The properties of these paints are given below.

Type	Silver Lacquer	Metal Lacquer
Identifier	CC-2	341
Cure	Air Dry	Air Dry
Color	Silver	Metallic Gray
Service Temp.	300°F	275°F
Surface Resis.	Less than 1 ohm/ square	Less than 1 ohm/ square
Cost/sq ft of Material	\$1.00	\$0.30

All the data on these paint systems are sales data.

Choice of conducting paint or lacquer as the problem solution will require an overcoat of appropriate colored paint, as it is believed that the desired electrical properties cannot be maintained by striving for color and conductivity in one application.

#### Effects of Blade Repair on RCS

Small damaged areas on the blade may be repaired without replacing the electrical conducting surface ply or treated core without degrading the RCS of the total blade substantially. That is, an 8-inch square area not covered by a conductive skin should not increase the RCS of the total blade by a significant amount.

If the blade is coated with a conductive paint, kits for blade repair could be made up to include a small container of the conductive material to be used at the time the repair is made. An 8-inch square area not coated will have a negligible effect on the RCS of the blade.

Repair of a blade having a treated core would follow the same procedures used for a blade with an untreated core.

## APPENDIX V

### FAILURE MODES AND EFFECTS ANALYSIS

This appendix presents the computer output from the accumulation and computation of failure occurrences and dispositions for the current blade and for each design concept.

DAMAGE CATEGORY	ITEM	TYPE OF DAMAGE	INHERENT CAUSES	EXTERNAL CAUSES	DEFINITION	COMPONENT
1. DELAMINATED	1. 1	DELAMINATED			ABRASION SHEATH	
	1. 2				SPAR	
	1. 3				SKIN	
	1. 4				T. E. SPLINE	
	1. 5				ROOT DOUBLERS	
	1. 6				GRIP/DIAG PLATES	
	1. 7				GRIP PAD	
	1. 8				ROOT CLOSURE	
	1. 9				TIP CLOSURE	
	2. 1	CRACKED			SPAR	
	2. 2				SKIN	
	2. 3				T. E. SPLINE	
2. 4				TRIM TAB		
2. 5				ROOT DOUBLERS		
2. 6				GRIP/DIAG PLATES		
2. 7				GRIP PAD		
2. 8				GRIP/DIAG BUSHINGS		
2. 9				ROOT CLOSURE		
2. 10				TIP CLOSURE		
2. 11				ROOT CAP		
2. 12				TIP CAP		
3. CORRODED	3. 1	CORRODED			SPAR	
	3. 2				SKIN	
	3. 3				T. E. SPLINE	
	3. 4				TRIM TAB	
	3. 5				ROOT DOUBLERS	
	3. 6				GRIP/DIAG PLATES	
	3. 7				GRIP PAD	
	3. 8				GRIP/DIAG BUSHINGS	
	3. 9				ROOT CLOSURE	
	3. 10				TIP CLOSURE	
	3. 11				ROOT CAP	
	3. 12				TIP CAP	
4. ERODED	4. 1	ERODED			ABRASION SHEATH	
	4. 2				SKIN	
	4. 3				T. E. SPLINE	
	4. 4				TRIM TAB	
	4. 5				ROOT DOUBLERS	
	4. 6				GRIP/DIAG PLATES	
	4. 7				GRIP PAD	
	4. 8				ROOT CLOSURE	
	4. 9				TIP CLOSURE	
	4. 10				ROOT CAP	
	4. 11				TIP CAP	
	5. 12TH EYE SIZE EXTERNAL CAUSES	5. 1	12TH EYE SIZE EXTERNAL CAUSES			GRIP/DIAG BUSHINGS
6. 1		DENTED			ABRASION SHEATH	
6. 2					SPAR	
6. 3					SKIN	
6. 4					CORE	
6. 5					T. E. SPLINE	
6. 6					TRIM TAB	
6. 7					ROOT DOUBLERS	
6. 8					GRIP/DIAG PLATES	
6. 9					ROOT CLOSURE	
6. 10					TIP CLOSURE	
6. 11					ROOT CAP	
6. 12				TIP CAP		
7. 1 PUNCTURED/TORN	7. 1	PUNCTURED/TORN			ABRASION SHEATH	
	7. 2				SPAR	
	7. 3				SKIN	
	7. 4				CORE	
	7. 5				T. E. SPLINE	
	7. 6				TRIM TAB	
	7. 7				ROOT DOUBLERS	
	7. 8				GRIP/DIAG PLATES	
	7. 9				GRIP PAD	
	7. 10				ROOT CLOSURE	
	7. 11				TIP CLOSURE	
	7. 12				ROOT CAP	
	7. 13				TIP CAP	
8. 1 BENT/DISTORTED	8. 1	BENT/DISTORTED			SPAR	
	8. 2				T. E. SPLINE	
	8. 3				TRIM TAB	
	8. 4				TIP CAP	
9. 1 NICKED/SCRATCHED	9. 1	NICKED/SCRATCHED			ABRASION SHEATH	
	9. 2				SPAR	
	9. 3				SKIN	
	9. 4				T. E. SPLINE	
	9. 5				TRIM TAB	
	9. 6				ROOT DOUBLERS	
	9. 7				GRIP/DIAG PLATES	
	9. 8				GRIP PAD	
	9. 9				GRIP/DIAG BUSHINGS	
	9. 10				ROOT CLOSURE	
	9. 11				TIP CLOSURE	
	9. 12				ROOT CAP	
	9. 13				TIP CAP	
10. 1 LOOSE/MISSING	10. 1	LOOSE/MISSING			ROOT CAP	
	10. 2				TIP CAP	
	10. 3				TIP CAP	
11. 1 ABRADED	11. 1	ABRADED			ABRASION SHEATH	
	11. 2				SPAR	
	11. 3				SKIN	
	11. 4				ROOT DOUBLERS	
	11. 5				TIP CAP	
12. 1 OVERSTRESSED COMBAT CAUSES	12. 1	OVERSTRESSED COMBAT CAUSES			TOTAL BLADE	
13. 1 BATTLE DAMAGE	13. 1	BATTLE DAMAGE			ABRASION SHEATH	
	13. 2				SPAR	
	13. 3				SKIN	
	13. 4				CORE	
	13. 5				T. E. SPLINE	
	13. 6				TRIM TAB	
	13. 7				ROOT DOUBLERS	
	13. 8				GRIP/DIAG PLATES	
	13. 9				GRIP PAD	
	13. 10				ROOT CLOSURE	
	13. 11				TIP CLOSURE	
	13. 12				ROOT CAP	
	13. 13				TIP CAP	

CURRENT DN-TH MAIN MOTOR BLADE

ITEM	NUMBER OCCURS	FRACTIONAL DISPOSITIONS				MMH UN-AC	MTRR DN-AC	KIT OFF-A	NO.
		3N-AC	FIELD	DEFECT	DN-TH				
1. 1	104.0	0.000	0.432	0.000	0.568				
1. 2	123.0	0.000	0.432	0.000	0.568				
1. 3	544.0	0.000	0.432	0.000	0.568				
1. 4	40.0	0.000	0.432	0.000	0.568				
1. 5	24.0	0.000	0.432	0.000	0.568				
1. 6	7.0	0.000	0.432	0.000	0.568				
1. 7	10.0	0.000	0.432	0.000	0.568				
1. 8	8.0	0.000	0.432	0.000	0.568				
1. 9	6.0	0.000	0.432	0.000	0.568	1.60	1.60	3.10	3
2. 2	544.0	0.000	0.432	0.000	0.568	1.60	1.60	3.10	3
2. 3	64.0	0.000	0.432	0.000	0.568				
2. 4	1.0	0.000	0.432	0.000	0.568				
2. 5	12.0	0.000	0.432	0.000	0.568				
2. 6	2.0	0.000	0.432	0.000	0.568				
2. 7	4.0	0.000	0.432	0.000	0.568				
2. 8	1.0	0.000	0.432	0.000	0.568				
2. 9	2.0	0.000	0.432	0.000	0.568				
2.10	6.0	0.000	0.432	0.000	0.568	1.60	1.60	3.10	3
2.11	1.0	0.000	0.432	0.000	0.568				
3. 2	64.0	0.000	0.257	0.426	0.317				
3. 3	74.0	0.000	0.000	1.000	0.000				
3. 4	2.0	0.000	0.000	1.000	0.000				
3. 5	2.0	0.000	0.432	0.000	0.568				
3.10	1.0	0.000	0.000	1.000	0.000				
4. 1	43.0	0.000	0.000	1.000	0.000				
4. 2	34.0	0.000	0.000	1.000	0.000				
4. 3	98.0	0.000	0.000	1.000	0.000				
4. 4	3.0	0.000	0.000	1.000	0.000				
4. 5	52.0	0.000	0.432	0.000	0.568				
4. 6	10.0	0.000	0.432	0.000	0.568				
4. 7	20.0	0.000	0.432	0.000	0.568				
4. 8	10.0	0.000	0.432	0.000	0.568				
4. 9	1.0	0.000	0.000	1.000	0.000				
4.10	5.0	0.000	0.432	0.000	0.568				
4.11	1.0	0.000	0.000	1.000	0.000				
5. 1	152.0	0.000	0.432	0.000	0.568				
6. 1	246.0	0.000	0.174	0.000	0.826	0.80	0.80	0.90	1
6. 2	243.0	0.000	0.432	0.000	0.568				
6. 3	67.0	0.000	0.000	0.000	0.000	1.60	1.60	3.10	3
6. 4	173.0	0.000	0.000	1.000	0.000				
6. 5	176.0	0.000	0.160	0.000	0.840	0.60	0.60	0.60	1
6. 6	24.0	0.000	0.000	0.000	0.000	0.60	0.60	0.60	1
6. 7	193.0	0.000	0.432	0.000	0.568				
6. 8	62.0	0.000	0.432	0.000	0.568				
6. 9	31.0	0.000	0.432	0.000	0.568				
6.10	1.0	0.000	0.000	0.000	0.000	1.60	1.60	3.10	3
6.11	33.0	0.000	0.432	0.000	0.568				
6.12	3.0	0.000	0.432	0.000	0.568				
7. 1	370.0	0.000	0.716	0.000	0.284				
7. 2	62.0	0.000	0.432	0.000	0.568				
7. 3	369.0	0.000	0.131	0.869	0.131	1.60	1.60	3.10	3
7. 4	123.0	0.000	0.432	0.000	0.568				
7. 5	59.0	0.000	0.432	0.000	0.568				
7. 6	2.0	0.000	0.432	0.000	0.568				
7. 7	34.0	0.000	0.432	0.000	0.568				
7. 8	6.0	0.000	0.432	0.000	0.568				
7. 9	13.0	0.000	0.432	0.000	0.568				
7.10	6.0	0.000	0.432	0.000	0.568				
7.12	3.0	0.000	0.432	0.000	0.568				
8. 2	16.0	0.000	0.432	0.000	0.568				
8. 3	1.0	0.000	0.432	0.000	0.568				
9. 1	123.0	0.000	0.000	0.905	0.095	0.40	0.40	0.40	1
9. 2	61.0	0.000	0.432	0.000	0.568				
9. 3	243.0	0.000	0.432	0.000	0.568				
9. 4	60.0	0.000	0.432	0.000	0.568				
9. 5	2.0	0.000	0.432	0.000	0.568				
9. 6	32.0	0.000	0.432	0.000	0.568				
9. 7	6.0	0.000	0.432	0.000	0.568				
9. 8	13.0	0.000	0.432	0.000	0.568				
9. 9	1.0	0.000	0.432	0.000	0.568				
9.10	6.0	0.000	0.432	0.000	0.568				
9.11	3.0	0.000	0.432	0.000	0.568				
9.12	3.0	0.000	0.432	0.000	0.568				
9.13	1.0	0.000	0.432	0.000	0.568				
10. 1	1.0	0.000	0.000	0.000	0.000	1.60	1.60	3.10	3
10. 2	4.0	0.000	0.000	0.000	0.000	1.60	1.60	3.10	3
11. 1	5.0	0.000	0.432	0.000	0.568				
11. 3	6.0	0.000	0.432	0.000	0.568				
11. 4	2.0	0.000	0.432	0.000	0.568				
11. 5	2.0	0.000	0.432	0.000	0.568				
12. 1	133.0	0.000	0.432	0.000	0.568				
13. 1	62.0	0.000	0.432	0.000	0.568				
13. 9	60.0	0.000	0.432	0.000	0.568				
13. 3	244.0	0.000	0.432	0.000	0.568				
13. 4	305.0	0.000	0.420	0.000	0.580				
13. 5	140.0	0.000	0.275	0.000	0.725	0.70	0.70	0.70	1
13. 6	4.0	0.000	0.000	0.000	0.000	0.70	0.70	0.70	1
13. 7	34.0	0.000	0.432	0.000	0.568				
13. 8	6.0	0.000	0.432	0.000	0.568				
13. 9	13.0	0.000	0.432	0.000	0.568				
13.10	6.0	0.000	0.432	0.000	0.568				
13.11	5.0	0.000	0.432	0.000	0.568				
13.12	3.0	0.000	0.432	0.000	0.568				
13.13	1.0	0.000	0.432	0.000	0.568				

7329.0 TOTAL DAMAGE EVENTS

CURRENT UH-1H MAIN ROTOR BLADE

TOTAL DAMAGE EVENTS IN SAMPLE = 7329.0

FRACTION DAMAGED SENT TO DEPOT = 0.5440  
 FRACTION DAMAGED REPAIRED ON AIRCRAFT = 0.0000  
 FRACTION DMGD. RPRD. OFF A/C IN FIELD = 0.1240  
 FRACTION DAMAGED SCRAPPED IN FIELD = 0.3320  
 FRACTION DAMAGED REPAIRED AT DEPOT = 0.1412  
 FRACTION DAMAGED SCRAPPED AT DEPOT = 0.4020

MEAN ADHESIVE CURE TIME FOR ALL RPRD. = 0.291 HOURS  
 ON-AIRCRAFT REPAIR ACTIVE MMH = 0.000  
 OFF-AIRCRAFT FIELD REPAIR ACTIVE MMH = 0.331  
 ON-AIRCRAFT REPAIR MTR = 0.000 HOURS  
 OFF-AIRCRAFT FIELD REPAIR MTR = 1.122 HOURS  
 MEAN ACTIVE MAINTENANCE TIME = 1.122 HOURS  
 MEAN CORRECTIVE MAINTENANCE DOWNTIME = 3.750 HOURS  
 ELAPSED TIME TO REMOVE, REPLACE, ETC. = 3.750 HOURS

AVERAGE KIT USE PER FIELD REPAIR:

KIT NO.	ON AIRCRAFT	OFF AIRCRAFT
1	0.000	0.306
2	0.000	0.000
3	0.000	0.124

95TH PERCENTILE MAXIMUM REPAIR TIME = 2.206 HOURS  
 95TH PERCENTILE MAXIMUM REPAIR DOWNTIME = 6.453 HOURS  
 95TH PERCENTILE MAXIMUM DAMAGE DOWNTIME = 3.750 HOURS

SURVIVABILITY FACTOR = 1.000

CURRENT UH-1H MRS \*\*\*\*\* NO COMBAT DAMAGE

TOTAL DAMAGE EVENTS IN SAMPLE = 6406.0

FRACTION DAMAGED SENT TO DEPOT = 0.5459  
 FRACTION DAMAGED REPAIRED ON AIRCRAFT = 0.0000  
 FRACTION DMGD. RPD. OFF A/C IN FIELD = 0.1323  
 FRACTION DAMAGED SCRAPPED IN FIELD = 0.3217  
 FRACTION DAMAGED REPAIRED AT DEPOT = 0.1624  
 FRACTION DAMAGED SCRAPPED AT DEPOT = 0.3335

MEAN ADHESIVE CURE TIME FOR ALL RPRS. = 0.312 HOURS  
 ON-AIRCRAFT REPAIR ACTIVE MMH = 0.000  
 OFF-AIRCRAFT FIELD REPAIR ACTIVE MMH = 0.340  
 ON-AIRCRAFT REPAIR MTR = 0.000 HOURS  
 OFF-AIRCRAFT FIELD REPAIR MTR = 1.152 HOURS  
 MEAN ACTIVE MAINTENANCE TIME = 1.152 HOURS  
 MEAN CORRECTIVE MAINTENANCE DOWNTIME = 3.750 HOURS  
 ELAPSED TIME TO REMOVE, REPLACE, ETC. = 3.750 HOURS

AVERAGE KIT USE PER FIELD REPAIR:

KIT NO.	ON AIRCRAFT	OFF AIRCRAFT
1	0.000	0.792
2	0.000	0.000
3	0.000	0.203

95TH PERCENTILE MAXIMUM REPAIR TIME = 2.255 HOURS  
 95TH PERCENTILE MAXIMUM REPAIR DOWNTIME = 6.453 HOURS  
 95TH PERCENTILE MAXIMUM DAMAGE DOWNTIME = 3.750 HOURS

SURVIVABILITY FACTOR = 1.144

DAMAGE CATEGORIES (FR/E BLADE DESIGNS 1,2,9,10,11 & 18)

ITEM	TYPE OF DAMAGE INTERNAL CAUSES	COMPONENT
1. 1	DELAMINATED	SPAR
1. 2		SKIN
1. 3		T. E. SPLINE
1. 4		TRIM TAB
1. 5		ROOT DOORLENS
1. 6		GRIP/DHAG PLATES
1. 7		GRIP PAD
1. 8		ROOT CLOSURE
1. 9		TIP CLOSURE
2. 1	CRACKED	SPAR
2. 2		SKIN
2. 3		T. E. SPLINE
2. 4		TRIM TAB
2. 5		ROOT DOORLENS
2. 6		GRIP/DHAG PLATES
2. 7		GRIP PAD
2. 8		GRIP/DHAG BUSHINGS
2. 9		ROOT CLOSURE
2.10		TIP CLOSURE
2.11		ROOT CAP
2.12		TIP CAP
3. 1	CORRODED	SPAR
3. 2		T. E. SPLINE
3. 3		TRIM TAB
3. 4		ROOT DOORLENS
3. 5		GRIP/DHAG PLATES
3. 6		GRIP PAD
3. 7		GRIP/DHAG BUSHINGS
3. 8		ROOT CLOSURE
3. 9		ROOT CAP
3.10		TIP CAP
4. 1	EMBDED	SPAR
4. 2		TIP CAP
5. 1	W-DAM OVERSIZE EXTERNAL CAUSES	GRIP/DHAG BUSHINGS
6. 1	DENTED	SPAR
6. 2		SKIN
6. 3		CONE
6. 4		T. E. SPLINE
6. 5		TRIM TAB
6. 6		ROOT DOORLENS
6. 7		GRIP/DHAG PLATES
6. 8		ROOT CLOSURE
6. 9		TIP CLOSURE
6.10		ROOT CAP
6.11		TIP CAP
7. 1	PUNCTURED/TORN	SPAR
7. 2		SKIN
7. 3		CORE
7. 4		T. E. SPLINE
7. 5		TRIM TAB
7. 6		ROOT DOORLENS
7. 7		GRIP/DHAG PLATES
7. 8		GRIP PAD
7. 9		ROOT CLOSURE
7.10		TIP CLOSURE
7.11		ROOT CAP
7.12		TIP CAP
8. 1	BENT/DISTORTED	SPAR
8. 2		T. E. SPLINE
8. 3		TRIM TAB
8. 4		TIP CAP
9. 1	NICKED/SCRATCHED	SPAR
9. 2		SKIN
9. 3		T. E. SPLINE
9. 4		TRIM TAB
9. 5		ROOT DOORLENS
9. 6		GRIP/DHAG PLATES
9. 7		GRIP PAD
9. 8		GRIP/DHAG BUSHINGS
9. 9		ROOT CLOSURE
9.10		TIP CLOSURE
9.11		ROOT CAP
9.12		TIP CAP
10. 1	LOOSE/MISSING	TIP CAP
11. 1	ARRAZED	SPAR
11. 2		SKIN
11. 3		ROOT DOORLENS
11. 4		TIP CAP
12. 1	OVERSTRESSED CYCLIC CAUSES	TOTAL BLADE
13. 1	FATIGUE DAMAGE	SPAR
13. 2		SKIN
13. 3		CONE
13. 4		T. E. SPLINE
13. 5		TRIM TAB
13. 6		ROOT DOORLENS
13. 7		GRIP/DHAG PLATES
13. 8		GRIP PAD
13. 9		ROOT CLOSURE
13.10		TIP CLOSURE
13.11		ROOT CAP
13.12		TIP CAP

FIELD REPAIRABLE EXPENDABLE DESIGNS 1,2,7,10

UNIT	FRAGMENTS				MINE		MTR		KILL
	NO.	WEIGHT	VELOCITY	DEPTH	TYPE	CLASS	CLASS	CLASS	
1.1	1	37.0	0.000	1.000	0.000	0.000			
1.2	1	31.0	0.000	1.000	0.000	0.000	0.93	0.93	1.60
1.3	1	38.0	0.000	1.000	0.000	0.000			4
1.5	1	3.0	0.000	1.000	0.000	0.000			
1.6	1	6.0	0.000	1.000	0.000	0.000			
1.7	1	3.0	0.000	1.000	0.000	0.000			
1.8	1	4.0	0.000	1.000	0.000	0.000			
1.9	1	4.0	0.000	1.000	0.000	0.000			
2.1	1	3.0	0.000	1.000	0.000	0.000			
2.2	1	245.0	0.000	1.000	0.000	0.000	0.43	0.43	1.35
2.3	1	61.0	0.000	1.000	0.000	0.000			5
2.4	1	1.0	0.000	1.000	0.000	0.000	0.93	0.93	1.76
2.5	1	3.0	0.000	1.000	0.000	0.000			1
2.6	1	3.0	0.000	1.000	0.000	0.000			
2.7	1	5.0	0.000	1.000	0.000	0.000			
2.8	1	1.0	0.000	1.000	0.000	0.000			
2.9	1	2.0	0.000	1.000	0.000	0.000			
2.10	1	2.0	0.000	1.000	0.000	0.000	0.43	0.43	1.35
2.11	1	1.0	0.000	1.000	0.000	0.000			5
2.12	1	1.0	0.000	1.000	0.000	0.000			
3.1	1	137.0	0.000	1.000	0.000	0.000	0.20	0.20	1.33
3.2	1	12.0	0.000	1.000	0.000	0.000	0.63	0.63	1.33
3.3	1	1.0	0.000	1.000	0.000	0.000	0.63	0.63	1.33
3.4	1	2.0	0.000	1.000	0.000	0.000			3
3.5	1	72.0	0.000	1.000	0.000	0.000	0.63	0.63	1.33
3.6	1	4.0	0.000	1.000	0.000	0.000	0.63	0.63	1.33
3.7	1	2.0	0.000	1.000	0.000	0.000			3
3.8	1	2.0	0.000	1.000	0.000	0.000			
3.9	1	2.0	0.000	1.000	0.000	0.000	0.63	0.63	1.76
3.10	1	2.0	0.000	1.000	0.000	0.000	0.31	0.31	1.34
4.1	1	175.0	0.000	1.000	0.000	0.000	0.63	0.63	1.33
4.2	1	1.0	0.000	1.000	0.000	0.000	0.41	0.41	1.33
5.1	1	105.0	0.000	1.000	0.000	0.000			3
6.2	1	44.0	0.000	1.000	0.000	0.000	0.93	0.93	1.60
6.3	1	41.0	0.000	1.000	0.000	0.000	0.93	0.93	1.60
6.4	1	171.0	0.000	1.000	0.000	0.000	0.93	0.93	1.71
6.5	1	6.0	0.000	1.000	0.000	0.000	0.93	0.93	1.76
6.6	1	171.0	0.000	1.000	0.000	0.000			1
6.7	1	7.0	0.000	1.000	0.000	0.000			
6.8	1	22.0	0.000	1.000	0.000	0.000			
6.9	1	1.0	0.000	1.000	0.000	0.000			
6.10	1	3.0	0.000	1.000	0.000	0.000			
6.11	1	5.0	0.000	1.000	0.000	0.000	0.20	0.20	1.33
7.1	1	245.0	0.000	1.000	0.000	0.000			0
7.2	1	214.0	0.000	1.000	0.000	0.000	0.93	0.93	1.60
7.3	1	213.0	0.000	1.000	0.000	0.000	0.93	0.93	1.60
7.4	1	112.0	0.000	1.000	0.000	0.000			4
7.5	1	3.0	0.000	1.000	0.000	0.000	0.93	0.93	1.76
7.6	1	37.0	0.000	1.000	0.000	0.000			1
7.7	1	6.0	0.000	1.000	0.000	0.000			
7.8	1	12.0	0.000	1.000	0.000	0.000			
7.9	1	6.0	0.000	1.000	0.000	0.000			
7.10	1	3.0	0.000	1.000	0.000	0.000	0.93	0.93	1.60
7.11	1	3.0	0.000	1.000	0.000	0.000			4
7.12	1	3.0	0.000	1.000	0.000	0.000	0.20	0.20	1.33
8.1	1	1.0	0.000	1.000	0.000	0.000			0
8.2	1	7.0	0.000	1.000	0.000	0.000			
8.3	1	1.0	0.000	1.000	0.000	0.000	0.31	0.31	0.71
8.4	1	1.0	0.000	1.000	0.000	0.000	0.20	0.20	1.33
9.1	1	14.0	0.000	1.000	0.000	0.000	0.63	0.63	1.33
9.2	1	304.0	0.000	1.000	0.000	0.000	0.63	0.63	1.35
9.3	1	2.0	0.000	1.000	0.000	0.000	0.63	0.63	1.33
9.4	1	1.0	0.000	1.000	0.000	0.000	0.63	0.63	1.33
9.5	1	15.0	0.000	1.000	0.000	0.000	0.63	0.63	1.33
9.6	1	3.0	0.000	1.000	0.000	0.000	0.63	0.63	1.33
9.7	1	7.0	0.000	1.000	0.000	0.000	0.73	0.73	1.41
9.8	1	2.0	0.000	1.000	0.000	0.000	0.60	0.60	1.76
9.9	1	3.0	0.000	1.000	0.000	0.000	0.63	0.63	1.33
9.10	1	1.0	0.000	1.000	0.000	0.000	0.43	0.43	1.33
9.11	1	2.0	0.000	1.000	0.000	0.000	0.63	0.63	1.76
9.12	1	2.0	0.000	1.000	0.000	0.000	0.31	0.31	1.34
10.1	1	4.0	0.000	1.000	0.000	0.000	0.1	0.04	1.03
10.2	1	5.0	0.000	1.000	0.000	0.000	0.63	0.63	1.34
10.3	1	3.0	0.000	1.000	0.000	0.000	0.43	0.43	1.35
10.4	1	2.0	0.000	1.000	0.000	0.000			5
10.5	1	1.0	0.000	1.000	0.000	0.000	0.20	0.20	1.33
10.6	1	720.0	0.000	1.000	0.000	0.000			0
10.7	1	214.0	0.000	1.000	0.000	0.000			
10.8	1	253.0	0.000	1.000	0.000	0.000	1.36	1.36	2.33
10.9	1	251.0	0.000	1.000	0.000	0.000	1.36	1.36	2.33
10.10	1	21.0	0.000	1.000	0.000	0.000			4
10.11	1	3.0	0.000	1.000	0.000	0.000	0.93	0.93	1.76
10.12	1	33.0	0.000	1.000	0.000	0.000			1
10.13	1	6.0	0.000	1.000	0.000	0.000			
10.14	1	11.0	0.000	1.000	0.000	0.000			
10.15	1	6.0	0.000	1.000	0.000	0.000			
10.16	1	2.0	0.000	1.000	0.000	0.000	1.36	1.36	2.33
10.17	1	3.0	0.000	1.000	0.000	0.000			4
10.18	1	3.0	0.000	1.000	0.000	0.000			
10.19	1	2.0	0.000	1.000	0.000	0.000	0.20	0.20	1.33

-----  
 571.0 TOTAL DAMAGE EVENTS

FIELD REPAIRABLE/EXPENDABLE DESIGNS 11 & 12

ITEM	FRACTIONAL DISPOSITIONS					MMH		MTM		KIT NO.
	NUMBER OCCURS	UN-AC	REPAIR SCHAP	FIELD REPAIR SCHAP	DEPT SCHAP	UN-AC	OFF-A	UN-AC	OFF-A	
1. 1	37.0	0.000	1.000	0.000	0.000					
1. 2	342.0	1.000	0.000	0.000	0.000	0.93	0.93	1.60	1.60	4
1. 3	74.0	0.000	1.000	0.000	0.000					
1. 5	3.0	0.000	1.000	0.000	0.000					
1. 6	6.0	0.000	1.000	0.000	0.000					
1. 7	3.0	0.000	1.000	0.000	0.000					
1. 8	4.0	0.000	1.000	0.000	0.000					
1. 9	4.0	0.000	1.000	0.000	0.000					
2. 1	3.0	0.000	1.000	0.000	0.000					
2. 2	112.5	1.000	0.000	0.000	0.000	0.43	0.43	1.35	1.35	5
2. 3	61.0	0.000	1.000	0.000	0.000					
2. 4	1.0	1.000	0.000	0.000	0.000	0.93	0.93	1.76	1.76	1
2. 5	3.0	0.000	1.000	0.000	0.000					
2. 6	3.0	0.000	1.000	0.000	0.000					
2. 7	3.0	0.000	1.000	0.000	0.000					
2. 8	1.0	0.000	1.000	0.000	0.000					
2. 9	2.0	0.000	1.000	0.000	0.000					
2.10	2.0	0.000	1.000	0.000	0.000	0.43	0.43	1.35	1.35	5
2.11	1.0	0.000	1.000	0.000	0.000					
2.12	1.0	1.000	0.000	0.000	0.000	0.20	0.20	1.33	1.33	0
3. 1	137.0	1.000	0.000	0.000	0.000	0.63	0.63	1.38	1.38	3
3. 2	62.0	1.000	0.000	0.000	0.000	0.43	0.43	1.33	1.33	3
3. 3	1.0	1.000	0.000	0.000	0.000	0.63	0.63	1.38	1.38	3
3. 4	2.0	0.000	1.000	0.000	0.000					
3. 5	72.0	0.000	0.000	0.000	0.000	0.63	0.63	1.38	1.33	3
3. 6	4.0	0.000	0.000	0.000	0.000	0.60	0.60	0.76	0.76	3
3. 7	3.0	0.000	1.000	0.000	0.000					
3. 8	2.0	0.000	1.000	0.000	0.000					
3. 9	2.0	0.000	0.000	0.000	0.000	0.63	0.63	1.76	1.76	3
3.10	2.0	1.000	0.000	0.000	0.000	0.31	0.31	1.34	1.34	3
4. 1	125.0	1.000	0.000	0.000	0.000	0.63	0.63	1.38	1.38	3
4. 2	1.0	1.000	0.000	0.000	0.000	0.41	0.41	1.35	1.35	3
5. 1	105.0	0.000	1.000	0.000	0.000					
6. 4	174.0	0.343	0.657	0.000	0.000	0.30	0.30	0.71	0.71	0
6. 5	6.0	1.000	0.000	0.000	0.000	0.73	0.73	1.76	1.76	1
6. 6	178.0	0.000	1.000	0.000	0.000					
6. 7	70.0	0.000	1.000	0.000	0.000					
6. 8	20.0	0.000	1.000	0.000	0.000					
6. 9	2.0	0.000	1.000	0.000	0.000					
6.10	3.0	0.000	1.000	0.000	0.000					
6.11	3.0	1.000	0.000	0.000	0.000	0.20	0.20	1.33	1.33	0
7. 1	245.0	0.000	1.000	0.000	0.000					
7. 2	142.0	1.000	0.000	0.000	0.000	0.93	0.93	1.60	1.60	4
7. 3	142.0	1.000	0.000	0.000	0.000	0.93	0.93	1.60	1.60	4
7. 4	112.0	0.000	1.000	0.000	0.000					
7. 5	3.0	1.000	0.000	0.000	0.000	0.93	0.93	1.76	1.76	1
7. 6	37.0	0.000	1.000	0.000	0.000					
7. 7	4.0	0.000	1.000	0.000	0.000					
7. 8	12.0	0.000	1.000	0.000	0.000					
7. 9	6.0	0.000	1.000	0.000	0.000					
7.10	3.0	0.657	0.333	0.000	0.000	0.93	0.93	1.60	1.60	4
7.11	3.0	0.000	1.000	0.000	0.000					
7.12	3.0	1.000	0.000	0.000	0.000	0.20	0.20	1.33	1.33	0
8. 1	1.0	0.000	1.000	0.000	0.000					
8. 2	7.0	0.000	1.000	0.000	0.000					
8. 3	1.0	1.000	0.000	0.000	0.000	0.30	0.30	0.71	0.71	1
8. 4	1.0	1.000	0.000	0.000	0.000	0.20	0.20	1.33	1.33	0
9. 1	141.0	1.000	0.000	0.000	0.000	0.43	0.43	1.34	1.34	3
9. 2	153.0	1.000	0.000	0.000	0.000	0.43	0.43	1.35	1.35	5
9. 3	2.0	1.000	0.000	0.000	0.000	0.63	0.63	1.34	1.34	3
9. 4	1.0	1.000	0.000	0.000	0.000	0.63	0.63	1.34	1.34	3
9. 5	15.0	0.000	0.000	0.000	0.000	0.63	0.63	1.34	1.38	3
9. 6	3.0	0.000	0.000	0.000	0.000	0.63	0.63	1.34	1.34	3
9. 7	7.0	0.000	0.000	0.000	0.000	0.73	0.73	1.43	1.43	3
9. 8	2.0	0.000	0.000	0.000	0.000	0.60	0.60	0.76	0.76	3
9. 9	3.0	0.000	0.000	0.000	0.000	0.63	0.63	1.31	1.33	3
9.10	1.0	1.000	0.000	0.000	0.000	0.43	0.43	1.35	1.35	3
9.11	2.0	0.000	0.000	0.000	0.000	0.63	0.63	1.76	1.76	3
9.12	2.0	1.000	0.000	0.000	0.000	0.31	0.31	1.34	1.34	3
10. 1	4.0	1.000	0.000	0.000	0.000	0.03	0.03	0.03	0.04	0
11. 1	1.0	1.000	0.000	0.000	0.000	0.63	0.63	1.34	1.34	3
11. 3	2.0	0.000	1.000	0.000	0.000					
11. 4	1.0	1.000	0.000	0.000	0.000	0.20	0.20	1.33	1.33	0
12. 1	73.0	0.000	1.000	0.000	0.000					
13. 1	216.0	0.000	1.000	0.000	0.000					
13. 2	125.0	1.000	0.000	0.000	0.000	1.36	1.36	2.03	2.03	4
13. 3	125.0	1.000	0.000	0.000	0.000	1.36	1.36	2.03	2.03	4
13. 4	91.0	0.000	1.000	0.000	0.000					
13. 5	3.0	1.000	0.000	0.000	0.000	0.93	0.93	1.76	1.76	1
13. 6	33.0	0.000	1.000	0.000	0.000					
13. 7	4.0	0.000	1.000	0.000	0.000					
13. 9	11.0	0.000	1.000	0.000	0.000					
13.10	2.0	0.000	1.000	0.000	0.000	1.36	1.36	2.03	2.03	4
13.11	3.0	0.000	1.000	0.000	0.000					
13.12	2.0	1.000	0.000	0.000	0.000	0.20	0.20	1.33	1.33	0

4153.5 TOTAL DAMAGE EVENTS

FIELD REPAIRABLE/EXPENDABLE DESIGNS 1,2,9, & 10

TOTAL DAMAGE EVENTS IN SAMPLE = 5413.0

FRACTION DAMAGED SENT TO DEPOT = 0.0000  
 FRACTION DAMAGED REPAIRED ON AIRCRAFT = 0.5930  
 FRACTION DMGD. WPD. OFF A/C IN FIELD = 0.0189  
 FRACTION DAMAGED SCRAPPED IN FIELD = 0.3681  
 FRACTION DAMAGED REPAIRED AT DEPOT = 0.0000  
 FRACTION DAMAGED SCRAPPED AT DEPOT = 0.0000

MEAN ADHESIVE CURE TIME FOR ALL RPKS. = 0.718 HOURS  
 ON-AIRCRAFT REPAIR ACTIVE MMH = 0.955  
 OFF-AIRCRAFT FIELD REPAIR ACTIVE MMH = 0.635  
 ON-AIRCRAFT REPAIR MTR = 1.573 HOURS  
 OFF-AIRCRAFT FIELD REPAIR MTR = 1.366 HOURS  
 MEAN ACTIVE MAINTENANCE TIME = 1.567 HOURS  
 MEAN CORRECTIVE MAINTENANCE DOWNTIME = 2.459 HOURS  
 ELAPSED TIME TO REMOVE, REPLACE, ETC. = 3.750 HOURS

AVERAGE KIT USE PER FIELD REPAIR:

KIT NO.	ON AIRCRAFT	OFF AIRCRAFT
1	0.004	0.000
2	0.000	0.000
3	0.143	1.000
4	0.670	-0.000
5	0.155	0.000

95TH PERCENTILE MAXIMUM REPAIR TIME = 2.327 HOURS  
 95TH PERCENTILE MAXIMUM REPAIR DOWNTIME = 2.991 HOURS  
 95TH PERCENTILE MAXIMUM DAMAGE DOWNTIME = 3.231 HOURS

SURVIVABILITY FACTOR = 1.261

FRZE BLADE DESIGNS 1,2,9 & 10 \*\*\*\*\* NO COMBAT DAMAGE

TOTAL DAMAGE EVENTS IN SAMPLE = 4932.0

FRACTION DAMAGED SENT TO DEPOT = 0.0000

FRACTION DAMAGED REPAIRED ON AIRCRAFT = 0.5961

FRACTION DMGD. RPRD. OFF A/C IN FIELD = 0.0223

FRACTION DAMAGED SCRAPPED IN FIELD = 0.3816

FRACTION DAMAGED REPAIRED AT DEPOT = 0.0000

FRACTION DAMAGED SCRAPPED AT DEPOT = 0.0000

MEAN ADHESIVE CURE TIME FOR ALL RPRS. = 0.726 HOURS

ON-AIRCRAFT REPAIR ACTIVE MMH = 0.767

OFF-AIRCRAFT FIELD REPAIR ACTIVE MMH = 0.635

ON-AIRCRAFT REPAIR MTR = 1.495 HOURS

OFF-AIRCRAFT FIELD REPAIR MTR = 1.366 HOURS

MEAN ACTIVE MAINTENANCE TIME = 1.490 HOURS

MEAN CORRECTIVE MAINTENANCE DOWNTIME = 2.406 HOURS

ELAPSED TIME TO REMOVE, REPLACE, ETC. = 3.750 HOURS

AVERAGE KIT USE PER FIELD REPAIR:

KIT NO.	ON AIRCRAFT	OFF AIRCRAFT
1	0.004	0.000
2	0.000	0.000
3	0.173	1.000
4	0.615	-0.000
5	0.132	0.000

95TH PERCENTILE MAXIMUM REPAIR TIME = 2.503 HOURS

95TH PERCENTILE MAXIMUM REPAIR DOWNTIME = 2.635 HOURS

95TH PERCENTILE MAXIMUM DAMAGE DOWNTIME = 3.034 HOURS

SURVIVABILITY FACTOR = 1.436

FIELD REPAIRABLE/EXPENDABLE DESIGNS 11 & 12

TOTAL DAMAGE EVENTS IN SAMPLE = 4153.5

FRACTION DAMAGED SENT TO DEPOT = 0.0000

FRACTION DAMAGED REPAIRED ON AIRCRAFT = 0.4304

FRACTION DMGD. RPRD. OFF A/C IN FIELD = 0.0265

FRACTION DAMAGED SCRAPPED IN FIELD = 0.5431

FRACTION DAMAGED REPAIRED AT DEPOT = 0.0000

FRACTION DAMAGED SCRAPPED AT DEPOT = 0.0000

MEAN ADHESIVE CURE TIME FOR ALL RPRS. = 0.725 HOURS

ON-AIRCRAFT REPAIR ACTIVE MMH = 0.300

OFF-AIRCRAFT FIELD REPAIR ACTIVE MMH = 0.635

ON-AIRCRAFT REPAIR MTR = 1.525 HOURS

OFF-AIRCRAFT FIELD REPAIR MTR = 1.366 HOURS

MEAN ACTIVE MAINTENANCE TIME = 1.516 HOURS

MEAN CORRECTIVE MAINTENANCE DOWNTIME = 2.792 HOURS

ELAPSED TIME TO REMOVE, REPLACE, ETC. = 3.750 HOURS

AVERAGE KIT USE PER FIELD REPAIR:

KIT NO.	ON AIRCRAFT	OFF AIRCRAFT
1	0.003	0.000
2	0.000	0.000
3	0.235	1.000
4	0.514	-0.000
5	0.149	0.000

95TH PERCENTILE MAXIMUM REPAIR TIME = 2.551 HOURS

95TH PERCENTILE MAXIMUM REPAIR DOWNTIME = 2.347 HOURS

95TH PERCENTILE MAXIMUM DAMAGE DOWNTIME = 3.268 HOURS

SURVIVABILITY FACTOR = 1.765

FIVE BLADE DESIGNS 11 & 12 SEEB NO COMBAT DAMAGE

TOTAL DAMAGE EVENTS IN SAMPLE = 3523.5

FRACTION DAMAGED SENT TO DEPOT = 0.0000

FRACTION DAMAGED REPAIRED ON AIRCRAFT = 0.4347

FRACTION DMGD. RPD. OFF A/C IN FIELD = 0.0312

FRACTION DAMAGED SCRAPPED IN FIELD = 0.5341

FRACTION DAMAGED REPAIRED AT DEPOT = 0.0000

FRACTION DAMAGED SCRAPPED AT DEPOT = 0.0000

MEAN ADHESIVE CURE TIME FOR ALL RPRS. = 0.733 HOURS

ON-AIRCRAFT REPAIR ACTIVE MMH = 0.709

OFF-AIRCRAFT FIELD REPAIR ACTIVE MMH = 0.635

ON-AIRCRAFT REPAIR MTR = 1.442 HOURS

OFF-AIRCRAFT FIELD REPAIR MTR = 1.366 HOURS

MEAN ACTIVE MAINTENANCE TIME = 1.437 HOURS

MEAN CORRECTIVE MAINTENANCE DOWNTIME = 2.747 HOURS

ELAPSED TIME TO REMOVE, REPLACE, ETC. = 3.750 HOURS

AVERAGE KIT USE PER FIELD REPAIR:

KIT NO.	ON AIRCRAFT	OFF AIRCRAFT
1	0.007	0.000
2	0.000	0.000
3	0.333	1.000
4	0.436	-0.000
5	0.174	0.000

95TH PERCENTILE MAXIMUM REPAIR TIME = 2.242 HOURS

95TH PERCENTILE MAXIMUM REPAIR DOWNTIME = 2.563 HOURS

95TH PERCENTILE MAXIMUM DAMAGE DOWNTIME = 3.127 HOURS

SURVIVABILITY FACTOR = 2.030

DAMAGE CATEGORIES (FRZ) BLADE DESIGN 3,4,5, & 6)

ITEM	TYPE OF DAMAGE INTERNAL CAUSES	COMPONENT
1. 1	DELAMINATED	SPAR
1. 2		SKIN
1. 3		T. E. SPLINE
1. 4		TRIM TAB
1. 5		ROOT DOUBLERS
1. 6		GRIP/DRAG PLATES
1. 7		GRIP PAD
1. 8		ROOT CLOSURE
1. 9		TIP CLOSURE
2. 1	CRACKED	SPAR
2. 2		SKIN
2. 3		T. E. SPLINE
2. 4		TRIM TAB
2. 5		ROOT DOUBLERS
2. 6		GRIP/DRAG PLATES
2. 7		GRIP PAD
2. 8		GRIP/DRAG BUSHINGS
2. 9		ROOT CLOSURE
2.10		TIP CLOSURE
2.11		ROOT CAP
2.12		TIP CAP
3. 1	CHIPPED	TRIM TAB
3. 2		TIP CAP
4. 1	ERODED	SPAR
4. 2		TIP CAP
5. 1	WORN/OVERSIZE EXTERNAL CAUSES	GRIP/DRAG BUSHINGS
6. 1	DENTED	SPAR
6. 2		SKIN
6. 3		CONE
6. 4		TRIM TAB
6. 5		ROOT DOUBLERS
6. 6		GRIP/DRAG PLATES
6. 7		ROOT CLOSURE
6. 8		TIP CLOSURE
6. 9		ROOT CAP
6.10		TIP CAP
7. 1	PUNCTURED/TORN	SPAR
7. 2		SKIN
7. 3		CONE
7. 4		T. E. SPLINE
7. 5		TRIM TAB
7. 6		ROOT DOUBLERS
7. 7		GRIP/DRAG PLATES
7. 8		GRIP PAD
7. 9		ROOT CLOSURE
7.10		TIP CLOSURE
7.11		ROOT CAP
7.12		TIP CAP
9. 1	BENT/DISTORTED	SPAR
9. 2		T. E. SPLINE
9. 3		TRIM TAB
9. 4		TIP CAP
9. 1	NICKED/SCHATCHED	SPAR
9. 2		SKIN
9. 3		TRIM TAB
9. 4		ROOT DOUBLERS
9. 5		GRIP/DRAG PLATES
9. 6		GRIP PAD
9. 7		GRIP/DRAG BUSHINGS
9. 8		ROOT CLOSURE
9. 9		TIP CLOSURE
9.10		ROOT CAP
9.11		TIP CAP
10. 1	LAME/MISSING	TIP CAP
11. 1	ABRADED	SPAR
11. 2		SKIN
11. 3		ROOT DOUBLERS
11. 4		TIP CAP
12. 1	OVERSTRESSED EXTERNAL CAUSES	TOTAL BLADE
13. 1	GRAVEL DAMAGE	SPAR
13. 2		SKIN
13. 3		CONE
13. 4		T. E. SPLINE
13. 5		TRIM TAB
13. 6		ROOT DOUBLERS
13. 7		GRIP/DRAG PLATES
13. 8		GRIP PAD
13. 9		ROOT CLOSURE
13.10		TIP CLOSURE
13.11		ROOT CAP
13.12		TIP CAP

FIELD REPAIRABLE/EXCHANGEABLE DESIGNS 3 & 5

ITEM	NUMBER OCCURS	FRACTIONAL DISPOSITIONS				MMH		MTR		KIT No.
		UN-AC	FIELD REPAIR	DEPOT SCRAP	DEPOT	UN-AC	OFF-A	UN-AC	OFF-A	
1. 1	106.0	0.000	1.000	0.000	0.000					
1. 2	413.0	1.000	0.000	0.000	0.000	0.73	0.73	1.60	1.60	4
1. 3	31.0	0.000	1.000	0.000	0.000					
1. 5	3.0	0.000	1.000	0.000	0.000					
1. 6	3.0	0.000	1.000	0.000	0.000					
1. 7	3.0	0.000	1.000	0.000	0.000					
1. 8	3.0	0.000	1.000	0.000	0.000					
1. 9	3.0	0.000	1.000	0.000	0.000					
2. 1	9.0	0.000	1.000	0.000	0.000					
2. 2	235.0	1.000	0.000	0.000	0.000	0.43	0.43	1.35	1.35	5
2. 4	1.0	1.000	0.000	0.000	0.000	0.73	0.73	1.76	1.76	1
2. 5	15.0	0.000	1.000	0.000	0.000					
2. 6	3.0	0.000	1.000	0.000	0.000					
2. 7	5.0	0.000	1.000	0.000	0.000					
2. 8	1.0	0.000	1.000	0.000	0.000					
2. 9	1.0	0.000	1.000	0.000	0.000					
2.10	2.0	0.000	0.500	0.000	0.000	0.43	0.43	1.35	1.35	5
2.11	1.0	0.000	1.000	0.000	0.000					
2.12	1.0	1.000	0.000	0.000	0.000	0.20	0.20	1.35	1.35	0
3. 1	1.0	1.000	0.000	0.000	0.000	0.63	0.63	1.33	1.33	3
3. 2	2.0	0.500	0.500	0.000	0.000	0.41	0.41	1.27	1.27	3
4. 1	33.0	1.000	0.000	0.000	1.000	0.73	0.73	1.43	1.43	3
4. 2	2.0	1.000	0.000	0.000	0.000	0.20	0.20	1.33	1.33	0
5. 1	150.0	0.000	1.000	0.000	0.000					
6. 2	370.0	1.000	0.000	0.000	0.000	0.73	0.73	1.60	1.60	4
6. 3	353.0	1.000	0.000	0.000	0.000	0.73	0.73	1.60	1.60	4
6. 4	6.0	1.000	0.000	0.000	0.000	0.73	0.73	1.76	1.76	1
6. 5	173.0	0.000	1.000	0.000	0.000					
6. 6	70.0	0.000	1.000	0.000	0.000					
6. 7	15.0	0.000	1.000	0.000	0.000					
6. 8	2.0	0.000	1.000	0.000	0.000					
6. 9	4.0	0.000	1.000	0.000	0.000					
6.10	7.0	1.000	0.000	0.000	0.000	0.20	0.20	1.33	1.33	0
7. 1	437.0	0.000	1.000	0.000	0.000					
7. 2	217.0	1.000	0.000	0.000	0.000	0.73	0.73	1.60	1.60	4
7. 3	204.0	1.000	0.000	0.000	0.000	0.73	0.73	1.60	1.60	4
7. 4	264.0	0.000	1.000	0.000	0.000					
7. 5	3.0	1.000	0.000	0.000	0.000	0.73	0.73	1.76	1.76	1
7. 6	27.0	0.000	1.000	0.000	0.000					
7. 7	6.0	0.000	1.000	0.000	0.000					
7. 8	12.0	0.000	1.000	0.000	0.000					
7. 9	5.0	0.000	1.000	0.000	0.000					
7.10	4.0	0.000	0.500	0.000	0.000	0.73	0.73	1.60	1.60	4
7.11	8.0	0.000	1.000	0.000	0.000					
7.12	4.0	1.000	0.000	0.000	0.000	0.20	0.20	1.33	1.33	0
8. 1	2.0	0.000	1.000	0.000	0.000					
8. 2	26.0	0.000	1.000	0.000	0.000					
8. 3	1.0	1.000	0.000	0.000	0.000	0.73	0.73	1.76	1.76	1
8. 4	1.0	1.000	0.000	0.000	0.000	0.20	0.20	1.33	1.33	0
9. 1	274.0	1.000	0.000	0.000	0.000	0.73	0.73	1.43	1.43	3
9. 2	243.0	1.000	0.000	0.000	0.000	0.43	0.43	1.35	1.35	5
9. 3	1.0	1.000	0.000	0.000	0.000	0.63	0.63	1.33	1.33	3
9. 4	15.0	0.000	0.000	0.000	0.000	0.73	0.73	1.43	1.43	3
9. 5	71.0	0.000	0.730	0.000	0.000	0.50	0.50	1.33	1.33	3
9. 6	11.0	1.000	0.000	0.000	0.000	0.57	0.57	1.22	1.22	3
9. 7	3.0	0.000	0.500	0.000	0.000	0.33	0.33	0.75	0.75	3
9. 8	3.0	0.000	0.000	0.000	0.000	0.73	0.73	1.43	1.43	3
9. 9	1.0	1.000	0.000	0.000	0.000	0.43	0.43	1.35	1.35	4
9.10	1.0	0.000	0.000	0.000	0.000	0.73	0.73	1.31	1.31	5
9.11	1.0	1.000	0.000	0.000	0.000	0.20	0.20	1.33	1.33	0
10. 1	4.0	1.000	0.000	0.000	0.000	0.73	0.73	0.95	0.95	3
11. 1	1.0	1.000	0.000	0.000	0.000	0.73	0.73	1.43	1.43	3
11. 2	3.0	1.000	0.000	0.000	0.000	0.43	0.43	1.35	1.35	5
11. 3	2.0	0.000	1.000	0.000	0.000					
11. 4	1.0	1.000	0.000	0.000	0.000	0.20	0.20	1.33	1.33	0
12. 1	723.0	0.000	1.000	0.000	0.000					
13. 1	337.0	0.000	1.000	0.000	0.000					
13. 2	193.0	1.000	0.000	0.000	0.000	1.36	1.36	2.03	2.03	4
13. 3	173.0	1.000	0.000	0.000	0.000	1.36	1.36	2.03	2.03	4
13. 4	7.0	0.000	1.000	0.000	0.000					
13. 5	3.0	1.000	0.000	0.000	0.000	0.73	0.73	1.76	1.76	1
13. 6	22.0	0.000	1.000	0.000	0.000					
13. 7	6.0	0.000	1.000	0.000	0.000					
13. 8	11.0	0.000	1.000	0.000	0.000					
13. 9	4.0	0.000	1.000	0.000	0.000					
13.10	2.0	0.000	0.500	0.000	0.000	0.73	0.73	1.60	1.60	4
13.11	4.0	1.000	0.000	0.000	0.000					
13.12	3.0	1.000	0.000	0.000	0.000	0.20	0.20	1.33	1.33	0

\*\*\*\*\*  
S&S-D TOTAL DAMAGE EVENTS

FIELD REPAIRABLE/EXPENDABLE DESIGNS 4 & 6

ITEM	NUMBER OCCURS	FRACTIONAL DISPOSITIONS				MMH		MTH		KIT NO.
		ON-AC	FIELD	DEPOT	DEPOT	ON-AC	OFF-A	ON-AC	OFF-A	
1. 1	106.0	0.000	1.000	0.000	0.000					
1. 2	413.0	1.000	0.000	0.000	0.000	0.93	0.93	1.60	1.60	4
1. 3	31.0	0.000	1.000	0.000	0.000					
1. 5	3.0	0.000	1.000	0.000	0.000					
1. 6	3.0	0.000	1.000	0.000	0.000					
1. 7	3.0	0.000	1.000	0.000	0.000					
1. 8	3.0	0.000	1.000	0.000	0.000					
1. 9	3.0	0.000	1.000	0.000	0.000					
2. 1	4.0	0.000	1.000	0.000	0.000					
2. 2	226.0	1.000	0.000	0.000	0.000	0.43	0.43	1.35	1.35	5
2. 4	1.0	1.000	0.000	0.000	0.000	0.73	0.73	1.76	1.76	1
2. 5	12.0	0.000	1.000	0.000	0.000					
2. 6	3.0	0.000	1.000	0.000	0.000					
2. 7	5.0	0.000	1.000	0.000	0.000					
2. 8	1.0	0.000	1.000	0.000	0.000					
2. 9	1.0	0.000	1.000	0.000	0.000					
2.10	2.0	0.500	0.500	0.000	0.000	0.43	0.43	1.35	1.35	5
2.11	1.0	0.000	1.000	0.000	0.000					
2.12	1.0	1.000	0.000	0.000	0.000	0.20	0.20	1.33	1.33	0
3. 1	1.0	1.000	0.000	0.000	0.000	0.63	0.63	1.38	1.38	3
3. 2	2.0	0.500	0.500	0.000	0.000	0.41	0.41	1.27	1.27	3
4. 1	33.0	1.000	0.000	0.000	0.000	0.73	0.73	1.44	1.44	3
4. 2	2.0	1.000	0.000	0.000	0.000	0.20	0.20	1.33	1.33	0
5. 1	150.0	0.000	1.000	0.000	0.000					
6. 2	394.0	1.000	0.000	0.000	0.000	0.93	0.93	1.60	1.60	4
6. 3	379.0	1.000	0.000	0.000	0.000	0.93	0.93	1.60	1.60	4
6. 4	6.0	1.000	0.000	0.000	0.000	0.93	0.93	1.76	1.76	1
6. 5	173.0	0.000	1.000	0.000	0.000					
6. 6	70.0	0.000	1.000	0.000	0.000					
6. 7	15.0	0.000	1.000	0.000	0.000					
6. 8	2.0	0.000	1.000	0.000	0.000					
6. 9	4.0	0.000	1.000	0.000	0.000					
6.10	7.0	1.000	0.000	0.000	0.000	0.20	0.20	1.33	1.33	0
7. 1	395.0	0.000	1.000	0.000	0.000					
7. 2	241.0	1.000	0.000	0.000	0.000	0.73	0.73	1.60	1.60	4
7. 3	226.0	1.000	0.000	0.000	0.000	0.73	0.73	1.60	1.60	4
7. 4	364.0	0.000	1.000	0.000	0.000					
7. 5	3.0	1.000	0.000	0.000	0.000	0.93	0.93	1.76	1.76	1
7. 6	37.0	0.000	1.000	0.000	0.000					
7. 7	6.0	0.000	1.000	0.000	0.000					
7. 8	12.0	0.000	1.000	0.000	0.000					
7. 9	5.0	0.000	1.000	0.000	0.000					
7.10	4.0	0.500	0.500	0.000	0.000	0.73	0.73	1.60	1.60	4
7.11	9.0	0.000	1.000	0.000	0.000					
7.12	4.0	1.000	0.000	0.000	0.000	0.20	0.20	1.33	1.33	0
9. 1	2.0	0.000	1.000	0.000	0.000					
9. 2	26.0	0.000	1.000	0.000	0.000					
9. 3	1.0	1.000	0.000	0.000	0.000	0.93	0.93	1.76	1.76	1
9. 4	1.0	1.000	0.000	0.000	0.000	0.20	0.20	1.33	1.33	0
9. 1	247.0	1.000	0.000	0.000	0.000	0.73	0.73	1.44	1.44	3
9. 2	270.0	1.000	0.000	0.000	0.000	0.43	0.43	1.35	1.35	5
9. 3	1.0	1.000	0.000	0.000	0.000	0.63	0.63	1.38	1.38	3
9. 4	15.0	0.000	1.000	0.000	0.000	0.73	0.73	1.44	1.44	3
9. 5	71.0	0.000	0.750	0.000	0.000	0.63	0.63	1.38	1.38	3
9. 6	11.0	1.000	0.000	0.000	0.000	0.64	0.64	1.22	1.22	3
9. 7	5.0	0.000	0.600	0.000	0.000	0.60	0.60	0.76	0.76	3
9. 8	3.0	0.000	0.000	0.000	0.000	0.73	0.73	1.44	1.44	3
9. 9	1.0	1.000	0.000	0.000	0.000	0.43	0.43	1.35	1.35	4
9.10	2.0	0.000	0.000	0.000	0.000	0.73	0.73	1.31	1.31	3
9.11	1.0	1.000	0.000	0.000	0.000	0.20	0.20	1.33	1.33	0
10. 1	4.0	1.000	0.000	0.000	0.000	0.04	0.04	0.08	0.08	0
11. 1	5.0	1.000	0.000	0.000	0.000	0.73	0.73	1.48	1.48	3
11. 2	3.0	1.000	0.000	0.000	0.000	0.43	0.43	1.35	1.35	5
11. 3	2.0	0.000	1.000	0.000	0.000					
11. 4	1.0	1.000	0.000	0.000	0.000	0.20	0.20	1.33	1.33	0
12. 1	733.0	0.000	1.000	0.000	0.000					
13. 1	343.0	0.000	1.000	0.000	0.000					
13. 2	213.0	1.000	0.000	0.000	0.000	1.36	1.36	2.03	2.03	4
13. 3	199.0	1.000	0.000	0.000	0.000	1.36	1.36	2.03	2.03	4
13. 4	28.0	0.000	1.000	0.000	0.000					
13. 5	3.0	1.000	0.000	0.000	0.000	0.93	0.93	1.76	1.76	1
13. 6	33.0	0.000	1.000	0.000	0.000					
13. 7	6.0	0.000	1.000	0.000	0.000					
13. 8	11.0	0.000	1.000	0.000	0.000					
13. 9	4.0	0.000	1.000	0.000	0.000					
13.10	2.0	0.500	0.500	0.000	0.000	0.93	0.93	1.60	1.60	4
13.11	4.0	0.000	1.000	0.000	0.000					
13.12	3.0	1.000	0.000	0.000	0.000	0.20	0.20	1.33	1.33	0

-----  
5715.0 TOTAL DAMAGE EVENTS

FIELD REPAIRABLE/EXPENDABLE DESIGNS 3 & 5

TOTAL DAMAGE EVENTS IN SAMPLE = 5680.0

FRACTION DAMAGED SENT TO DEPOT = 0.0000  
 FRACTION DAMAGED REPAIRED ON AIRCRAFT = 0.4923  
 FRACTION DMGD. RPRD. OFF A/C IN FIELD = 0.0044  
 FRACTION DAMAGED SCRAPPED IN FIELD = 0.5028  
 FRACTION DAMAGED REPAIRED AT DEPOT = 0.0000  
 FRACTION DAMAGED SCRAPPED AT DEPOT = 0.0000

MEAN ADHESIVE CURE TIME FOR ALL RPRS. = 0.724 HOURS  
 ON-AIRCRAFT REPAIR ACTIVE MMH = 0.875  
 OFF-AIRCRAFT FIELD REPAIR ACTIVE MMH = 0.703  
 ON-AIRCRAFT REPAIR MTR = 1.599 HOURS  
 OFF-AIRCRAFT FIELD REPAIR MTR = 1.397 HOURS  
 MEAN ACTIVE MAINTENANCE TIME = 1.593 HOURS  
 MEAN CORRECTIVE MAINTENANCE DOWNTIME = 2.690 HOURS  
 ELAPSED TIME TO REMOVE, REPLACE, ETC. = 3.750 HOURS

AVERAGE KIT USE PER FIELD REPAIR:

KIT NO.	ON AIRCRAFT	OFF AIRCRAFT
1	0.005	0.000
2	0.000	0.000
3	0.119	1.000
4	0.698	0.000
5	0.169	0.000

95TH PERCENTILE MAXIMUM REPAIR TIME = 2.974 HOURS  
 95TH PERCENTILE MAXIMUM REPAIR DOWNTIME = 3.018 HOURS  
 95TH PERCENTILE MAXIMUM DAMAGE DOWNTIME = 3.373 HOURS

SURVIVABILITY FACTOR = 1.290

FR/E BLADE DESIGNS 3 & 5 \*\*\*\*\* NO COMBAT DAMAGE

TOTAL DAMAGE EVENTS IN SAMPLE = 4736.0

FRACTION DAMAGED SENT TO DEPOT = 0.0000

FRACTION DAMAGED REPAIRED ON AIRCRAFT = 0.5065

FRACTION DMGD. RPRD. OFF A/C IN FIELD = 0.0053

FRACTION DAMAGED SCRAPPED IN FIELD = 0.4882

FRACTION DAMAGED REPAIRED AT DEPOT = 0.0000

FRACTION DAMAGED SCRAPPED AT DEPOT = 0.0000

MEAN ADHESIVE CURE TIME FOR ALL RPRS. = 0.732 HOURS

ON-AIRCRAFT REPAIR ACTIVE MMH = 0.797

OFF-AIRCRAFT FIELD REPAIR ACTIVE MMH = 0.708

ON-AIRCRAFT REPAIR MTTR = 1.529 HOURS

OFF-AIRCRAFT FIELD REPAIR MTTR = 1.397 HOURS

MEAN ACTIVE MAINTENANCE TIME = 1.528 HOURS

MEAN CORRECTIVE MAINTENANCE DOWNTIME = 2.625 HOURS

ELAPSED TIME TO REMOVE, REPLACE, ETC. = 3.750 HOURS

AVERAGE KIT USE PER FIELD REPAIR:

KIT NO.	ON AIRCRAFT	OFF AIRCRAFT
1	0.005	0.000
2	0.000	0.000
3	0.139	1.000
4	0.651	0.000
5	0.197	0.000

95TH PERCENTILE MAXIMUM REPAIR TIME = 2.662 HOURS

95TH PERCENTILE MAXIMUM REPAIR DOWNTIME = 2.712 HOURS

95TH PERCENTILE MAXIMUM DAMAGE DOWNTIME = 3.204 HOURS

SURVIVABILITY FACTOR = 1.548

FIELD REPAIRABLE/EXPENDABLE DESIGNS 4 & 6

TOTAL DAMAGE EVENTS IN SAMPLE = 5715.0

FRACTION DAMAGED SENT TO DEPOT = 0.0000  
 FRACTION DAMAGED REPAIRED ON AIRCRAFT = 0.5106  
 FRACTION DMGD. RPRD. OFF A/C IN FIELD = 0.0044  
 FRACTION DAMAGED SCRAPPED IN FIELD = 0.4850  
 FRACTION DAMAGED REPAIRED AT DEPOT = 0.0000  
 FRACTION DAMAGED SCRAPPED AT DEPOT = 0.0000

MEAN ADHESIVE CURE TIME FOR ALL RPRS. = 0.723 HOURS  
 ON-AIRCRAFT REPAIR ACTIVE MMH = 0.377  
 OFF-AIRCRAFT FIELD REPAIR ACTIVE MMH = 0.703  
 ON-AIRCRAFT REPAIR MTR = 1.601 HOURS  
 OFF-AIRCRAFT FIELD REPAIR MTR = 1.397 HOURS  
 MEAN ACTIVE MAINTENANCE TIME = 1.599 HOURS  
 MEAN CORRECTIVE MAINTENANCE DOWNTIME = 2.653 HOURS  
 ELAPSED TIME TO REMOVE, REPLACE, ETC. = 3.750 HOURS

AVERAGE KIT USE PER FIELD REPAIR:

KIT NO.	ON AIRCRAFT	OFF AIRCRAFT
1	0.005	0.000
2	0.000	0.000
3	0.105	1.000
4	0.710	0.000
5	0.171	0.000

95TH PERCENTILE MAXIMUM REPAIR TIME = 2.982 HOURS  
 95TH PERCENTILE MAXIMUM REPAIR DOWNTIME = 3.025 HOURS  
 95TH PERCENTILE MAXIMUM DAMAGE DOWNTIME = 3.364 HOURS

SURVIVABILITY FACTOR = 1.282

FR/E BLADE DESIGNS 4 & 6 \*\*\*\*\* NO COMBAT DAMAGE

TOTAL DAMAGE EVENTS IN SAMPLE = 4791.0

FRACTION DAMAGED SENT TO DEPOT = 0.0000  
 FRACTION DAMAGED REPAIRED ON AIRCRAFT = 0.5216  
 FRACTION DMGD. RPRD. OFF A/C IN FIELD = 0.0052  
 FRACTION DAMAGED SCRAPPED IN FIELD = 0.4732  
 FRACTION DAMAGED REPAIRED AT DEPOT = 0.0000  
 FRACTION DAMAGED SCRAPPED AT DEPOT = 0.0000

MEAN ADHESIVE CURE TIME FOR ALL RPRS. = 0.731 HOURS  
 ON-AIRCRAFT REPAIR ACTIVE MMH = 0.798  
 OFF-AIRCRAFT FIELD REPAIR ACTIVE MMH = 0.708  
 ON-AIRCRAFT REPAIR MTR = 1.530 HOURS  
 OFF-AIRCRAFT FIELD REPAIR MTR = 1.397 HOURS  
 MEAN ACTIVE MAINTENANCE TIME = 1.529 HOURS  
 MEAN CORRECTIVE MAINTENANCE DOWNTIME = 2.592 HOURS  
 ELAPSED TIME TO REMOVE, REPLACE, ETC. = 3.750 HOURS

AVERAGE KIT USE PER FIELD REPAIR:

KIT NO.	ON AIRCRAFT	OFF AIRCRAFT
1	0.004	0.000
2	0.000	0.000
3	0.123	1.000
4	0.664	0.000
5	0.200	0.000

95TH PERCENTILE MAXIMUM REPAIR TIME = 2.669 HOURS  
 95TH PERCENTILE MAXIMUM REPAIR DOWNTIME = 2.717 HOURS  
 95TH PERCENTILE MAXIMUM DAMAGE DOWNTIME = 3.192 HOURS

SURVIVABILITY FACTOR = 1.530

DAMAGE CATEGORIES (FIELD REPAIRABLE/REPAIRABLE DESIGNS 7 & 8)

ITEM	TYPE OF DAMAGE INTERNAL CAUSES	COMPONENT
1. 1	DELAMINATED	ABRASION SHEATH
1. 2		SPAR
1. 3		SKIN
1. 4		T. E. SPLINE
1. 5		TRIM TAB
1. 6		ROOT DOUBLERS
1. 7		GRIP/DRAG PLATES
1. 8		GRIP PAD
1. 9		ROOT CLOSURE
1.10		TIP CLOSURE
2. 1	CRACKED	SPAR
2. 2		SKIN
2. 3		T. E. SPLINE
2. 4		TRIM TAB
2. 5		ROOT DOUBLERS
2. 6		GRIP/DRAG PLATES
2. 7		GRIP PAD
2. 8		GRIP/DRAG BUSHINGS
2. 9		ROOT CLOSURE
2.10		TIP CLOSURE
2.11		ROOT CAP
2.12		TIP CAP
3. 1	CORRODED	SPAR
3. 2		T. E. SPLINE
3. 3		TRIM TAB
3. 4		ROOT DOUBLERS
3. 5		GRIP/DRAG PLATES
3. 6		GRIP PAD
3. 7		GRIP/DRAG BUSHINGS
3. 8		ROOT CLOSURE
3. 9		ROOT CAP
3.10		TIP CAP
4. 1	ENDED	ABRASION SHEATH
4. 2		SPAR
4. 3		TIP CAP
5. 1	WORN OVERSIZE EXTERNAL CAUSES	GRIP/DRAG BUSHINGS
6. 1	DENTED	SPAR
6. 2		SKIN
6. 3		CONE
6. 4		T. E. SPLINE
6. 5		TRIM TAB
6. 6		ROOT DOUBLERS
6. 7		GRIP/DRAG PLATES
6. 8		ROOT CLOSURE
6. 9		TIP CLOSURE
6.10		ROOT CAP
6.11		TIP CAP
7. 1	PUNCTURED/TORN	ABRASION SHEATH
7. 2		SPAR
7. 3		SKIN
7. 4		CONE
7. 5		T. E. SPLINE
7. 6		TRIM TAB
7. 7		ROOT DOUBLERS
7. 8		GRIP/DRAG PLATES
7. 9		GRIP PAD
7.10		ROOT CLOSURE
7.11		TIP CLOSURE
7.12		ROOT CAP
7.13		TIP CAP
8. 1	BENT/DISTORTED	SPAR
8. 2		T. E. SPLINE
8. 3		TRIM TAB
8. 4		TIP CAP
9. 1	NICKED/SCATCHED	ABRASION SHEATH
9. 2		SPAR
9. 3		SKIN
9. 4		T. E. SPLINE
9. 5		TRIM TAB
9. 6		ROOT DOUBLERS
9. 7		GRIP/DRAG PLATES
9. 8		GRIP PAD
9. 9		GRIP/DRAG BUSHINGS
9.10		ROOT CLOSURE
9.11		TIP CLOSURE
9.12		ROOT CAP
9.13		TIP CAP
10. 1	LOOSE/MISSING	TIP CAP
11. 1	ABRADED	ABRASION SHEATH
11. 2		SPAR
11. 3		SKIN
11. 4		ROOT DOUBLERS
11. 5		TIP CAP
12. 1	OVER STRESSED COMBAT CAUSES	TOTAL BLADE
13. 1	BATTLE DAMAGE	ABRASION SHEATH
13. 2		SPAR
13. 3		SKIN
13. 4		CONE
13. 5		T. E. SPLINE
13. 6		TRIM TAB
13. 7		ROOT DOUBLERS
13. 8		GRIP/DRAG PLATES
13. 9		GRIP PAD
13.10		ROOT CLOSURE
13.11		TIP CLOSURE
13.12		ROOT CAP
13.13		TIP CAP

FIELD REPAIRABLE/EXPENDABLE DESIGNS 1 & 6

ITEM	FRACTIONAL DISPOSITIONS						MNF	MTIN	KIT
	NUMBER	UN-AC	REPAIR	SCRAP	REPAIR	SCRAP			
1. 1	16.0	1.000	0.000	0.000	0.000	0.000			
1. 2	37.0	0.000	1.000	0.000	0.000	0.000			
1. 3	392.0	1.000	0.000	0.000	0.000	0.000	0.73	0.73	1.60
1. 4	74.0	0.000	1.000	0.000	0.000	0.000			1.60
1. 6	3.0	0.000	1.000	0.000	0.000	0.000			
1. 7	6.0	0.000	1.000	0.000	0.000	0.000			
1. 8	3.0	0.000	1.000	0.000	0.000	0.000			
1. 9	4.0	0.000	1.000	0.000	0.000	0.000			
1.10	4.0	0.000	1.000	0.000	0.000	0.000			
2. 1	3.0	0.000	1.000	0.000	0.000	0.000			
2. 2	225.0	1.000	0.000	0.000	0.000	0.000	0.43	0.43	1.35
2. 3	61.0	0.000	1.000	0.000	0.000	0.000			1.35
2. 4	1.0	1.000	0.000	0.000	0.000	0.000	0.93	0.93	1.76
2. 5	3.0	0.000	1.000	0.000	0.000	0.000			1.76
2. 6	3.0	0.000	1.000	0.000	0.000	0.000			
2. 7	5.0	0.000	1.000	0.000	0.000	0.000			
2. 8	1.0	0.000	1.000	0.000	0.000	0.000			
2. 9	2.0	0.000	1.000	0.000	0.000	0.000			
2.10	2.0	0.500	0.500	0.000	0.000	0.000	0.43	0.43	1.35
2.11	1.0	0.000	1.000	0.000	0.000	0.000			1.35
2.12	1.0	1.000	0.000	0.000	0.000	0.000	0.23	0.20	1.33
3. 1	137.0	1.000	0.000	0.000	0.000	0.000	0.63	0.63	1.38
3. 2	82.0	1.000	0.000	0.000	0.000	0.000	0.63	0.63	1.33
3. 3	1.0	1.000	0.000	0.000	0.000	0.000	0.53	0.63	1.34
3. 4	2.0	0.000	1.000	0.000	0.000	0.000			1.34
3. 5	72.0	0.000	0.000	0.000	0.000	0.000	0.53	0.63	1.31
3. 6	4.0	0.000	0.000	0.000	0.000	0.000	0.60	0.60	0.76
3. 7	3.0	0.000	1.000	0.000	0.000	0.000			0.76
3. 8	2.0	0.000	1.000	0.000	0.000	0.000			
3. 9	2.0	0.000	0.000	0.000	0.000	0.000	1.53	0.63	1.76
3.10	2.0	1.000	0.000	0.000	0.000	0.000	0.31	0.31	1.34
4. 1	12.0	1.000	0.000	0.000	0.000	0.000	0.63	0.63	1.76
4. 2	113.0	1.000	0.000	0.000	0.000	0.000	0.63	0.63	1.34
4. 3	1.0	1.000	0.000	0.000	0.000	0.000	0.41	0.41	1.35
4. 4	105.0	0.000	1.000	0.000	0.000	0.000			1.35
4. 5	445.0	1.000	0.000	0.000	0.000	0.000	0.73	0.73	1.60
4. 6	410.0	1.000	0.000	0.000	0.000	0.000	0.73	0.73	1.60
4. 7	175.0	0.343	0.657	0.000	0.000	0.000	0.33	0.30	0.71
4. 8	6.0	1.000	0.000	0.000	0.000	0.000	0.73	0.73	1.76
4. 9	171.0	0.000	1.000	0.000	0.000	0.000			1.76
4. 10	70.0	0.000	1.000	0.000	0.000	0.000			
4. 11	20.0	0.000	1.000	0.000	0.000	0.000			
4. 12	2.0	0.000	1.000	0.000	0.000	0.000			
4.13	3.0	0.000	1.000	0.000	0.000	0.000			
4.14	5.0	1.000	0.000	0.000	0.000	0.000	0.23	0.23	1.33
5. 1	41.0	1.000	0.000	0.000	0.000	0.000	0.60	0.60	1.76
5. 2	245.0	0.000	1.000	0.000	0.000	0.000			1.76
5. 3	294.0	1.000	0.000	0.000	0.000	0.000	0.73	0.73	1.60
5. 4	275.0	1.000	0.000	0.000	0.000	0.000	0.73	0.73	1.60
5. 5	112.0	0.000	1.000	0.000	0.000	0.000			1.60
5. 6	3.0	1.000	0.000	0.000	0.000	0.000	0.73	0.73	1.76
5. 7	37.0	0.000	1.000	0.000	0.000	0.000			1.76
5. 8	6.0	0.000	1.000	0.000	0.000	0.000			
5. 9	12.0	0.000	1.000	0.000	0.000	0.000			
5.10	6.0	0.000	1.000	0.000	0.000	0.000			
5.11	3.0	0.667	0.333	0.000	0.000	0.000	0.73	0.73	1.60
5.12	3.0	0.000	1.000	0.000	0.000	0.000			1.60
5.13	3.0	1.000	0.000	0.000	0.000	0.000	0.20	0.20	1.33
6. 1	1.0	0.000	1.000	0.000	0.000	0.000			1.33
6. 2	7.0	0.000	1.000	0.000	0.000	0.000			
6. 3	1.0	1.000	0.000	0.000	0.000	0.000	0.00	0.00	0.71
6. 4	1.0	1.000	0.000	0.000	0.000	0.000	0.20	0.20	1.33
6. 5	40.0	1.000	0.000	0.000	0.000	0.000	0.60	0.60	1.76
6. 6	171.0	1.000	0.000	0.000	0.000	0.000	0.62	0.62	1.33
6. 7	305.0	1.000	0.000	0.000	0.000	0.000	0.62	0.62	1.33
6. 8	2.0	1.000	0.000	0.000	0.000	0.000	0.63	0.63	1.38
6. 9	1.0	1.000	0.000	0.000	0.000	0.000	0.63	0.63	1.34
6. 10	15.0	0.000	0.000	0.000	0.000	0.000	0.62	0.62	1.34
6. 11	3.0	0.000	0.000	0.000	0.000	0.000	0.65	0.62	1.33
6. 12	7.0	0.000	0.000	0.000	0.000	0.000	0.73	0.73	1.43
6. 13	2.0	0.000	0.000	0.000	0.000	0.000	0.63	0.60	0.76
6.14	3.0	0.000	0.000	0.000	0.000	0.000	0.62	0.62	1.34
6.15	1.0	1.000	0.000	0.000	0.000	0.000	0.43	0.42	1.35
6.16	2.0	0.000	0.000	0.000	0.000	0.000	0.63	0.63	1.76
6.17	2.0	1.000	0.000	0.000	0.000	0.000	0.31	0.31	1.34
6.18	4.0	1.000	0.000	0.000	0.000	0.000	0.01	0.01	0.01
6.19	3.0	1.000	0.000	0.000	0.000	0.000	0.60	0.60	1.76
6.20	5.0	1.000	0.000	0.000	0.000	0.000	0.60	0.60	1.31
6.21	3.0	1.000	0.000	0.000	0.000	0.000	0.43	0.43	1.35
6.22	2.0	0.000	1.000	0.000	0.000	0.000			1.35
6.23	1.0	1.000	0.000	0.000	0.000	0.000	0.70	0.20	1.33
6.24	733.0	0.000	1.000	0.000	0.000	0.000			1.33
6.25	42.0	1.000	0.000	0.000	0.000	0.000	0.60	0.60	1.76
6.26	216.0	0.000	1.000	0.000	0.000	0.000			1.76
6.27	250.0	1.000	0.000	0.000	0.000	0.000	1.35	1.36	2.03
6.28	251.0	1.000	0.000	0.000	0.000	0.000	1.36	1.36	2.03
6.29	23.0	0.000	1.000	0.000	0.000	0.000			2.03
6.30	3.0	1.000	0.000	0.000	0.000	0.000	0.73	0.73	1.76
6.31	33.0	0.000	1.000	0.000	0.000	0.000			1.76
6.32	5.0	0.000	1.000	0.000	0.000	0.000			
6.33	11.0	0.000	1.000	0.000	0.000	0.000			
6.34	6.0	0.000	1.000	0.000	0.000	0.000			
6.35	7.0	0.000	0.000	0.000	0.000	0.000	1.36	1.36	2.03
6.36	3.0	0.000	1.000	0.000	0.000	0.000			2.03
6.37	2.0	1.000	0.000	0.000	0.000	0.000	0.20	0.20	1.33

5219.0 TOTAL DAMAGE EVENTS

FIELD REPAIRABLE/EXPENDABLE DESIGNS 7 & 8

TOTAL DAMAGE EVENTS IN SAMPLE = 5919.0

FRACTION DAMAGED SENT TO DEPOT = 0.0000  
 FRACTION DAMAGED REPAIRED ON AIRCRAFT = 0.6003  
 FRACTION DMGD. RPRD. OFF A/C IN FIELD = 0.0136  
 FRACTION DAMAGED SCRAPPED IN FIELD = 0.3311  
 FRACTION DAMAGED REPAIRED AT DEPOT = 0.0000  
 FRACTION DAMAGED SCRAPPED AT DEPOT = 0.0000

MEAN ADHESIVE CURE TIME FOR ALL RPRS. = 0.737 HOURS  
 ON-AIRCRAFT REPAIR ACTIVE MMH = 0.847  
 OFF-AIRCRAFT FIELD REPAIR ACTIVE MMH = 0.635  
 ON-AIRCRAFT REPAIR MTTR = 1.584 HOURS  
 OFF-AIRCRAFT FIELD REPAIR MTTR = 1.366 HOURS  
 MEAN ACTIVE MAINTENANCE TIME = 1.573 HOURS  
 MEAN CORRECTIVE MAINTENANCE DOWNTIME = 2.450 HOURS  
 ELAPSED TIME TO REMOVE, REPLACE, ETC. = 3.750 HOURS

AVERAGE KIT USE PER FIELD REPAIR:

KIT NO.	ON AIRCRAFT	OFF AIRCRAFT
1	0.004	0.000
2	0.045	0.000
3	0.123	1.000
4	0.650	-0.000
5	0.151	0.000

95TH PERCENTILE MAXIMUM REPAIR TIME = 2.816 HOURS  
 95TH PERCENTILE MAXIMUM REPAIR DOWNTIME = 2.976 HOURS  
 95TH PERCENTILE MAXIMUM DAMAGE DOWNTIME = 3.218 HOURS

SURVIVABILITY FACTOR = 1.238

FRZE BLADE DESIGNS 7 & 3 PERKS NO COMBAT DAMAGE

TOTAL DAMAGE EVENTS IN SAMPLE	=	4996.0
FRACTION DAMAGED SENT TO DEPOT	=	0.0000
FRACTION DAMAGED REPAIRED ON AIRCRAFT	=	0.6013
FRACTION DAMG. RPAD. OFF A/C IN FIELD	=	0.0220
FRACTION DAMAGED SCRAPPED IN FIELD	=	0.3767
FRACTION DAMAGED REPAIRED AT DEPOT	=	0.0000
FRACTION DAMAGED SCRAPPED AT DEPOT	=	0.0000
MEAN ADHESIVE CURE TIME FOR ALL RPRS.	=	0.742 HOURS
ON-AIRCRAFT REPAIR ACTIVE MMH	=	0.765
OFF-AIRCRAFT FIELD REPAIR ACTIVE MMH	=	0.635
ON-AIRCRAFT REPAIR MTR	=	1.503 HOURS
OFF-AIRCRAFT FIELD REPAIR MTR	=	1.366 HOURS
MEAN ACTIVE MAINTENANCE TIME	=	1.503 HOURS
MEAN COLLECTIVE MAINTENANCE DOWNTIME	=	2.402 HOURS
ELAPSED TIME TO REMOVE, REPLACE, ETC.	=	3.750 HOURS
AVERAGE KIT USE PER FIELD REPAIR:		
KIT NO.	ON AIRCRAFT	OFF AIRCRAFT
1	0.004	0.000
2	0.040	0.000
3	0.151	1.000
4	0.602	-0.000
5	0.173	0.000
95TH PERCENTILE MAXIMUM REPAIR TIME	=	2.504 HOURS
95TH PERCENTILE MAXIMUM REPAIR DOWNTIME	=	2.633 HOURS
95TH PERCENTILE MAXIMUM DAMAGE DOWNTIME	=	3.029 HOURS
SURVIVABILITY FACTOR = 1.467		

APPENDIX VI  
MAINTENANCE ACTIONS AND TIMES

Predicted Maintenance Actions/MTTR For  
Field Repairable/Expendable Blade Designs

MTTR (Mean Time To Repair) = The total corrective maintenance time divided by the total number of corrective maintenance actions during a given period of time. This includes curing and drying times.

PMMH (Productive Maintenance Man-Hours) = The element of maintenance time during which a discrepancy is corrected by repairing in place or removing and replacing with a like serviceable item. This excludes curing and drying times.

Type Actions

A = Acceptable as is

I = Install replacement detail

R = Repair

S = Scrap Rotor Blade

The predicted maintenance actions for the four basic concepts are presented in Tables XXII and XXIII. The anticipated mean repair times are presented in Table XXIV.

TABLE XXII. PREDICTED MAINTENANCE ACTIONS/MTRR, CONCEPTS 1 AND 2

Blade Detail	Potential Damages								Loose or Missing Hardware
	Cracked	Bent/ Distorted	Punctured/ Torn	Delaminated	Dented	Corroded	Eroded	Nicks Scratched	
Abrasion sheath No. & type action PMMH MTRR Repair kit			90-I 0.60 1.76 2	16-I 0.60 1.76 2			15-I 0.60 1.76 2	40-I 0.60 1.76 2	
Spar No. & type action No. & type action PMMH MTRR Repair kit	3-S	1-S	461-S	37-S	489-A	137-R	118-R 57-A	35-A 108-R	
						0.63 1.38 3	0.63 1.38 3	0.63 1.38 3	
Skin No. & type action PMMH MTRR Repair kit	225-R 0.43 1.35 5			534-R 0.93 1.60 4	382-R 0.93 1.60 4	445-R 0.93 1.60 4	3-R 0.43 1.35 5	306-R 0.43 1.35 5	

TABLE XXII - Continued

Blade Detail	Potential Damages									
	Cracked	Bent/ Distorted	Punctured/ Torn	Delaminated	Dented	Corroded	Eroded	Nicks Scratched	Worn Oversize	Loose or Missing Hardware
Core										
No. & type action			536-R		410-R					
PMMH			0.93		0.93					
MTTR			1.60		1.60					
Repair kit			4		4					
T. E. Spline										
No. & type action	61-S	7-S	210-S	78-S	117-S	42-R	40-R	29-R		
No. & type action					61-R					
PMMH					0.30	0.63	0.63	0.63		
MTTR					0.71	1.38	1.38	1.38		
Repair kit					0	3	3	3		
Trim tab										
No. & type action	1-I	1-R	6-I		6-I	1-R		1-R		
PMMH	0.93	0.30	0.93		0.93	0.63		0.63		
MTTR	1.76	0.71	1.76		1.76	1.38		1.38		
Repair kit	1	1	1		1	3		3		

TABLE XXII - Continued

Blade Detail	Potential Damages									
	Cracked	Bent/ Distorted	Punctured/ Torn	Delaminated	Dented	Corroded	Eroded	Nicks Scratched	Worn Oversize	Loose or Missing Hardware
Root doublers										
No. & type action	3-S	70-S	3-S	178-S	2-S				15-R	
PMMH									0.63	
MTTR									1.38	
Repair kit									3	
Grip & drag plates										
No. & type action	3-S	12-S	3-S	70-S	2-R	70-S	3-R			
PMMH					0.63		0.63			
MTTR					1.38		1.38			
Repair kit					3		3			
Grip pads										
No. & type action	5-S	23-S	3-S		4-R		7-R			
PMMH					0.60		0.73			
MTTR					0.76		1.48			
Repair kits					3		3			

TABLE XXII - Continued

Blade Detail	Potential Damages									
	Cracked	Bent/ Distorted	Punctured/ Torn	Delaminated	Dented	Corroded	Eroded	Nicks Scratched	Worn Oversize	Loose or Missing Hardware
Grip & drag bushings No. & type action PMMH MTTR Repair kit	1-S					3-S		2-R 0.60 0.76 3	105-S	
Root closure No. & type action No. & type action PMMH MTTR Repair kit	2-S		12-S	4-S	20-S 20-A	2-S		3-R 0.63 1.38 3		
Tip closure No. & type action No. & type action PMMH MTTR Repair kit	1-S 1-R 0.43 1.35		2-S 3-R 0.93 1.60	4-S	2-S 3-A			1-R 1-A 0.43 1.35		

TABLE XXII - Continued

Blade Detail	Potential Damages									
	Cracked	Bent/ Distorted	Punctured/ Torn	Delaminated	Dented	Corroded	Eroded	Nicks Scratched	Worn Oversize	Loose or Missing Hardware
Root cap										
No. & type action	1-S		6-S		3-S	2-R				2-R
No. & type action					17-A					
PMMH						0.63				0.63
MTTR						1.76				1.76
Repair kit						3				3
Tip cap										
No. & type action	1-I	1-I	5-I		5-I	1-I	1-A	1-I		4-R
No. & type action						1-R	2-I	1-R		
PMMH	0.20	0.20	0.20		0.20	0.41	0.20	0.41		0.08
MTTR	1.33	1.33	1.33		1.33	1.35	1.33	1.35		0.08
Repair kit	0	0	0		0	3	0	3		0

TABLE XXIII. PREDICTED MAINTENANCE ACTIONS/MTR, CONCEPTS 3 AND 4

Blade Detail	Potential Damages									
	Cracked	Bent/ Distorted	Punctured/ Torn	Delaminated	Dented	Corroded	Eroded	Nicks Scratched	Worn Oversize	Loose or Missing Hardware
Abrasion sheath No. & type action PMMH MTRR Repair kit										
Spar No. & type action No. & type action PMMH MTRR Repair kit	9-S	2-S	826-S	106-S	551-A		60-A 46-R 0.73 1.48 3	274-R 0.73 1.48 3		
Skin No. & type action PMMH MTRR Repair kit	225-R 0.43 1.35 5		412-R 0.93 1.60 4	413-R 0.93 1.60 4	370-R 0.93 1.60 4		3-R 0.43 1.35 5	243-R 0.43 1.35 5		

TABLE XXIII - Continued

Blade Detail	Potential Damages									
	Cracked	Bent/ Distorted	Punctured/ Torn	Delaminated	Dented	Corroded	Eroded	Nicks Scratched	Worn Oversize	Loose or Missing Hardware
Core										
No. & type action			384-R		352-R					
PMMH			0.93		0.93					
MTTR			1.60		1.60					
Repair kit			4		4					
Spline										
No. & type action			209-S	31-S	253-S					26-S
PMMH										
MTTR										
Repair kit										
Trim tab										
No. & type action	1-I	1-I	6-I		6-I	1-R				1-R
PMMH	0.93	0.93	0.93		0.93	0.63				0.63
MTTR	1.76	1.76	1.76		1.76	1.38				1.38
Repair kit	1	1	1		1	3				3

TABLE XXIII - Continued

Blade Detail	Potential Damages									
	Cracked	Bent/ Distorted	Punctured/ Torn	Delaminated	Dented	Corroded	Eroded	Nicks Scratched	Worn Oversize	Loose or Missing Hardware
Root doublers										
No. & type action	12-S		70-S	3-S	178-S					
PMMH								15-R		
MTTR								0.73		
Repair kit								1.48		
								3		
Grip & drag plates										
No. & type action	3-S		12-S	3-S	70-S		70-S			
PMMH								3-R		
MTTR								0.63		
Repair kit								1.38		
								3		
Grip pad										
No. & type action	5-S		23-S	3-S						
PMMH								4-R		
MTTR								0.60		
Repair kit								0.76		
								3		
									7-R	
									0.73	
									1.48	
									3	

TABLE XXIII - Continued

Blade Detail	Potential Damages									
	Cracked	Bent/ Distorted	Punctured/ Torn	Delaminated	Dented	Corroded	Eroded	Nicks Scratched	Worn Oversize	Loose or Missing Hardware
Grip & drag bushings No. & type action PMMH MTTR Repair kit	1-S					3-S			2-R 150-S 0.60 0.76 3	
Root closure No. & type action No. & type action PMMH MTTR Repair kit	1-S		9-S	3-S	15-S 15-A				3-R 0.73 1.48 3	
Tip closure No. & type action No. & type action PMMH MTTR Repair kit	1-S 1-R 0.43 1.35 5		2-S 2-R 0.93 1.60 4	3-S	2-S 2-A				1-R 1-A 0.43 1.35 4	

TABLE XXIII - Continued

Blade Detail	Potential Damages									
	Cracked	Bent/ Distorted	Punctured/ Torn	Delaminated	Dented	Corroded	Eroded	Nicks Scratched	Worn Oversize	Loose or Missing Hardware
Root cap No. & type action	1-S		8-S		4-S			2-R		
No. & type action					21-A			0.73		
PMMH								1.31		
MTTR								3		
Repair kit										
Tip caps										
No. & type action	1-I	1-I	7-I		7-I	1-I	3-I	1-I		4-R
No. & type action	0.20	0.20	0.20		0.20	1-R	1-A	0.20		0.08
PMMH	1.33	1.33	1.33		1.33	0.41	0.20	1.33		0.08
MTTK	0	0	0		0	1.27	0	1.33		0
Repair kit						3		0		

TABLE XXIV. FIELD-REPAIRABLE/EXPENDABLE ROTOR  
BLADE (PRELIMINARY MEAN REPAIR TIMES)

Repair Procedure		Mean Repair Time (Man-Hours)			
No.	Standard Repair Procedure	Active Elapsed Repair Time	Paint/ Primer Solvent Dry Time	Adhesive Cure Time **	Total Elapsed Repair Time
1*	Patch/plug repair of skin/core area.	1.16	1.50	.50	3.16
2*	Patch/plug repair of large skin/core area - penetration of upper & lower skin surfaces.	1.61	1.50	.50	3.61
3*	Patch repair of fiberglass skin	.58	1.50	.50	2.58
4	Mechanical straightening	.38	1.50		1.88
5	Blend repair of aluminum	.63	1.83		2.46
6	Polish repair of steel blemishes	.60	.16		.76
7	Blend repair of steel	.73	1.83		2.56
8	Replacement of abrasion sheath	.60	.16	2.00	2.76
9	Replacement of trim tab	.93	1.50	.50	2.93
10	Replacement of tip cap	.33		1.00	1.33
<p>* Mean Repair Times based on repair procedures using nalgene hand-operated vacuum pump.</p> <p>** Adhesive curing by heating unit for all procedures except No. 8.</p>					

Field-Repairable/Expendable Main  
Rotor Blade Repair Kits and  
Equipment List

<u>Kit No.</u>	<u>Kit Description</u>
1	Trim tab replacement kit
2	Abrasion sheath replacement kit
3	Blending/polishing metal repair kit
4	Core/skin plug-patch repair kit
5	Skin patch kit

Tables XXV and XXVI present the repair kit contents and associated equipment.

TABLE XXV. REPAIR KIT CONTENTS

Item No.	Item	Description	Kit Quantity					
			1	2	3	4	5	
1	Alodine, brushable	1-oz bottle			1			
2	Brush	½ in. wide			1			
3	Brush	2 in. wide			1			
4	Abrasive paper	sheet, 9 in. sq, 150 grit			2	2		
5	Abrasive paper	sheet, 9 in. sq, 180 grit		2				
6	Abrasive paper	sheet, 9 in. sq, 200 grit		2			2	
7	Abrasive paper	sheet, 9 in. sq, 320 grit		2			2	
8	Abrasive paper	sheet, 9 in. sq, 400 grit		2			2	
9	Abrasive paper	sheet, 9 in. sq, 420 grit			2			
10	Cheesecloth	18 in. wide (Qty in ft )	10	20	12	15	10	
11	Compound, corrosion preventive	pint can (MIL-C-16173)						1
12	Cellophane	sheet, commercial grade (Qty. in ft.)			4			
13	Hard rubber	sheet, 1/16 x 8 x 16 in.			2			
14	Masking tape	roll, 1 in. wide			1			

TABLE XXV - Continued

Item No.	Item	Description	Kit Quantity				
			1	2	3	4	5
15	MEK solvent	pint can (TT-M-261)	1	2	1	2	1
16	Paint, black	3-oz aerosol can (MIL-L-81352)	1		1	1	1
17	Paint, olive drab	3-oz aerosol can (MIL-L-81352)	1		1	1	1
18	Primer pretreatment	pint can, (MIL-P-15328)			1		
19	Steel wool	fine commercial grade			1		
20	Trim tab	contractor made	1				
21	Wooden spatula	tongue depressor	2				2
22	Zinc, chromate primer	3-oz aerosol can	1		1	1	1
23	Hot-melt film adhesive	patch, 4 in. dia				3	3
24	Hot-melt film adhesive	patch, 6 in. dia				3	3
25	Hot-melt film adhesive	patch, 8 in. dia				3	3
26	Hot-melt film adhesive	sheet, 16 in. x 6 in.				2	2
27	Nomex (Hexcel)	sheet, 2½ x 8 x 16 in.				2	2
28	Hi-temp mylar tape	2 in. wide (Qty in ft)				10	10

TABLE XXV - Continued

Item NO.	Item	Description	Kit Quantity				
			1	2	3	4	5
29	Airline systems AS-401-1	adhesive, part A & B (tube)					2
	Epon 934 epoxy	adhesive (MMM-A-132)	1				1
	Metalset, A-4	adhesive (FSCM 90414)	1				1
	<p>Note: - The last two items are required as indicated, but not included in kits due to limited shelf life.</p> <p>- Epon 934 is preferable to metalset; however, both are acceptable.</p>						

TABLE XXVI. EQUIPMENT LIST, BLADE REPAIR

Item No.	Description	Kit Requirement					Note
		1	2	3	4	5	
1	Single-cut file			1			
2	Hack saw	1			1		
3	Dial indicator depth gage			1			
4	Optical depth gage (20 power)			1			
5	Heavy mallet						B
6	Bronze wire brush			1			
7	Putty knife		1				C
8	Electric heat lamp/gun	1			1		
9	Metal shears						
10	28-volt dc power source	1			1	1	
11	Standard hand tools						A,C
12	Scissors	1			1	1	
13	Bending tool & indicator						B
14	Wooden backup block ( $\frac{1}{2}$ x 8 x 16)					2	

TABLE XXVI - Continued

Item No.	Description	Kit Requirement					Note
		1	2	3	4	5	
15	Sealing compound, pint can (MIL-S-8802B)						C
16	Wrench (T101414)						A
17	Rotor blade sling & hoist						A
18	Corrosion preventive compound (MIL-C-11796)						A
19	Tip cap						C
20	Wooden backup block						B
21	Flat heating iron			1	1		
22	Router assembly & drill attachments			1	1		
23	4-in.- long knife				1		
<p>Note: A = Required for rotor blade removal &amp; installation.            B = Required for trim tab &amp; <sup>TE</sup>spline mechanical straightening.            C = Required for tip cap replacement.</p>							

## APPENDIX VII

### LIFE-CYCLE COST ANALYSIS

This appendix presents the computer output for the computation of life-cycle costs for the current blade and for each of the design concepts.

Basic parameters, where not given, are MTBF's based on the current blade at 600 and 1000 hours, and a fatigue life of 2500 hours. Fatigue lives of 1500, 2000, and 3000 hours were also used to establish the effect of service life variation.

HELICOPTER LIFE-CYCLE BLADE COSTS

CURRENT UH-1H MMR

NEW BLADE PRICE = \$ 3000  
 MEAN TIME BETWEEN FAILURES = 600.0 BLADE HOURS  
 FIELD REPAIRABILITY = 12.4 PERCENT

MEAN TIME BETWEEN MAINTENANCE ACTIONS (BLADE HOURS):  
 REPLACEMENTS = 737.6  
 REMOVALS FOR REPAIR OR REPLACEMENT = 931.7  
 REPAIRS = 2725.0  
 DAMAGE REPLACEMENTS = 769.4  
 UNSCHEDULED MAINTENANCE = 600.0  
 SCHEDULED MAINTENANCE (RETIREMENT) = 1703.9  
 ALL MAINTENANCE ACTIONS = 581.7

BLADE EVENTS PER AIRCRAFT LIFE CYCLE:  
 NUMBER LOST TO ATTRITION = 1.5000  
 NUMBER FATIGUE RETIRED UNDAMAGED = 0.5247  
 NUMBER REPAIRED ON AIRCRAFT = 0.0000  
 NUMBER REPAIRED OFF AIRCRAFT IN FIELD = 2.0609  
 NUMBER SCRAPPED IN FIELD = 5.5130  
 NUMBER DAMAGED AND RETIRED IN FIELD = 0.0462  
 NUMBER REPAIRED AT DEPOT = 1.6033  
 NUMBER SCRAPPED AT DEPOT = 4.5545  
 NUMBER DAMAGED AND RETIRED AT DEPOT = 2.3732  
 TOTAL NUMBER DAMAGED AND NOT REPAIRED = 12.9969  
 TOTAL NUMBER ALL REPLACEMENTS = 13.5216

MAIN ROTOR BLADE COSTS PER AIRCRAFT LIFE CYCLE:

COST OF INITIAL PROCUREMENT:  
 NEW AIRCRAFT EQUIPPING COST = \$ 6000.00  
 SPARES COST, WITH CONTAINERS = \$ 2016.00  
 SPARE REPAIR MATERIALS = \$ 0.60  
 REPAIR SUPPORT EQUIPMENT = \$ 160.00  
 TOTAL INITIAL PROCUREMENT COST = \$ 8176.60

COST OF REPLACEMENT BLADES FOR THOSE LOST AND UNSERVICEABLE (INCLUDING  
 BLADE SHIPPING AND CONTAINER SHIPPING COSTS):  
 BLADES LOST TO ATTRITION = \$ 4762.50  
 DAMAGED BLADES NOT REPAIRED = \$42000.40  
 TIME-EXPIRED UNREPAIRED BLADES = \$ 1665.90  
 TOTAL REPLACEMENT COST = \$48428.70

COST OF MAINTENANCE ACTIONS (LABOR AND MATERIAL TO INSPECT, REMOVE,  
 REPAIR, REPLACE, ALIGN, AND TRACK):  
 FIELD REPAIR ON AIRCRAFT = \$ 0.00  
 FIELD REPAIR OFF AIRCRAFT = \$ 91.30  
 FIELD SCRAP = \$ 193.60  
 FIELD RETIREMENT = \$ 17.10  
 DEPOT REPAIR = \$ 1264.30  
 DEPOT SCRAP = \$ 920.00  
 DEPOT RETIREMENT = \$ 564.10  
 TOTAL MAINTENANCE COST = \$ 3755.60

TOTAL LIFE-CYCLE BLADE COST PER AIRCRAFT \$60,360.90  
 =====

MAINTENANCE MAN-HOURS/FLIGHT HOUR = 0.0313  
 BLADE-RELATED AIRCRAFT DOWNTIME = 23 HOURS  
 =====

HELICOPTER LIFE-CYCLE BLADE COSTS

CURRENT UH-1H MRB

NEW BLADE PRICE = \$ 3000  
 MEAN TIME BETWEEN FAILURES = 214.0 BLADE HOURS  
 FIELD REPAIRABILITY = 12.4 PERCENT

MEAN TIME BETWEEN MAINTENANCE ACTIONS (BLADE HOURS):

REPLACEMENTS = 1033.2  
 REMOVALS FOR REPAIR OR REPLACEMENT = 327.3  
 REPAIRS = 4151.1  
 DAMAGE REPLACEMENTS = 1172.1  
 UNSCHEDULED MAINTENANCE = 914.0  
 SCHEDULED MAINTENANCE (RETIREMENT) = 3720.2  
 ALL MAINTENANCE ACTIONS = 827.3

BLADE EVENTS PER AIRCRAFT LIFE CYCLE:

NUMBER LOST TO ATTRITION = 1.5000  
 NUMBER FATIGUE RETIRED UNDEMANAGED = 1.1463  
 NUMBER REPAIRED ON AIRCRAFT = 0.0000  
 NUMBER REPAIRED OFF AIRCRAFT IN FIELD = 1.3529  
 NUMBER SCRAPPED IN FIELD = 3.6223  
 NUMBER DAMAGED AND RETIRED IN FIELD = 0.0304  
 NUMBER REPAIRED AT DEPOT = 2.0561  
 NUMBER SCRAPPED AT DEPOT = 2.9378  
 NUMBER DAMAGED AND RETIRED AT DEPOT = 1.3394  
 TOTAL NUMBER DAMAGED AND NOT REPAIRED = 3.9317  
 TOTAL NUMBER ALL REPLACEMENTS = 9.6787

MAIN ROTOR BLADE COSTS PER AIRCRAFT LIFE CYCLE:

COST OF INITIAL PROCUREMENT:

NEW AIRCRAFT OUTFITTING COST = \$ 6000.00  
 SPARES COST, WITH CONTAINERS = \$ 2016.00  
 SPARE REPAIR MATERIALS = \$ 0.40  
 REPAIR SUPPORT EQUIPMENT = \$ 160.00  
 TOTAL INITIAL PROCUREMENT COST = \$ 8176.40

COST OF REPLACEMENT BLADES FOR THOSE LOST AND UNSERVICEABLE (INCLUDING BLADE SHIPPING AND CONTAINER SHIPPING COSTS):

BLADES LOST TO ATTRITION = \$ 4762.50  
 DAMAGED BLADES NOT REPAIRED = \$ 27126.10  
 TIME-EXPIRED UNDEMANAGED BLADES = \$ 3641.00  
 TOTAL REPLACEMENT COST = \$35529.60

COST OF MAINTENANCE ACTIONS (LABOR AND MATERIAL TO INSPECT, REMOVE, REPAIR, REPLACE, ALIGN, AND TRACK):

FIELD REPAIR ON AIRCRAFT = \$ 0.00  
 FIELD REPAIR OFF AIRCRAFT = \$ 60.00  
 FIELD SCRAP = \$ 130.40  
 FIELD REFINEMENT = \$ 35.30  
 DEPOT REPAIR = \$ 1289.50  
 DEPOT SCRAP = \$ 603.90  
 DEPOT RETIREMENT = \$ 370.30  
 TOTAL MAINTENANCE COST = \$ 2439.50

TOTAL LIFE-CYCLE BLADE COST PER AIRCRAFT \$46,195.40  
 =====

MAINTENANCE MAN-HOURS/FLIGHT HOUR = 0.0220  
 BLADE-RELATED AIRCRAFT DOWNTIME = 65 HOURS  
 =====

HELICOPTER LIFE-CYCLE BLADE COSTS

CURRENT UH-1H MAIN ROTOR BLADE

NEW BLADE PRICE = \$ 3000  
 MEAN TIME BETWEEN FAILURES = 1000.0 BLADE HOURS  
 FIELD REPAIRABILITY = 12.4 PERCENT

MEAN TIME BETWEEN MAINTENANCE ACTIONS (BLADE HOURS):  
 REPLACEMENTS = 1099.8  
 REMOVALS FOR REPAIR OR REPLACEMENT = 395.4  
 REPAIRS = 4541.7  
 DAMAGE REPLACEMENTS = 1232.4  
 UNSCHEDULED MAINTENANCE = 1000.0  
 SCHEDULED MAINTENANCE (RETIREMENT) = 7726.3  
 ALL MAINTENANCE ACTIONS = 885.4

BLADE EVENTS PER AIRCRAFT LIFE CYCLE:  
 NUMBER LOST TO ATTRITION = 1.5000  
 NUMBER FATIGUE RETIRED UN DAMAGED = 1.2942  
 NUMBER REPAIRED ON AIRCRAFT = 0.0000  
 NUMBER REPAIRED OFF AIRCRAFT IN FIELD = 1.2366  
 NUMBER SCRAPPED IN FIELD = 3.3103  
 NUMBER DAMAGED AND RETIRED IN FIELD = 0.0277  
 NUMBER REPAIRED AT DEPOT = 0.9653  
 NUMBER SCRAPPED AT DEPOT = 2.7327  
 NUMBER DAMAGED AND RETIRED AT DEPOT = 1.7269  
 TOTAL NUMBER DAMAGED AND NOT REPAIRED = 7.7932  
 TOTAL NUMBER ALL REPLACEMENTS = 9.0924

MAIN ROTOR BLADE COSTS PER AIRCRAFT LIFE CYCLE:

COST OF INITIAL PROCUREMENT:  
 NEW AIRCRAFT OUTFITTING COST = \$ 6000.00  
 SPARES COSTS WITH CONTAINERS = \$ 2016.00  
 SPARE REPAIR MATERIALS = \$ 0.30  
 REPAIR SUPPORT EQUIPMENT = \$ 160.00  
 TOTAL INITIAL PROCUREMENT COST = \$ 8176.30

COST OF REPLACEMENT BLADES FOR THOSE LOST AND UNSERVICEABLE (INCLUDING  
 BLADE SHIPPING AND CONTAINER SHIPPING COSTS):  
 BLADES LOST TO ATTRITION = \$ 4762.50  
 DAMAGED BLADES NOT REPAIRED = \$24633.90  
 TIME-EXPIRED UN DAMAGED BLADES = \$ 4109.10  
 TOTAL REPLACEMENT COST = \$33560.50

COST OF MAINTENANCE ACTIONS (LABOR AND MATERIAL TO INSPECT, REMOVE,  
 REPAIR, REPLACE, ALIGN, AND TRACK):  
 FIELD REPAIR ON AIRCRAFT = \$ 0.00  
 FIELD REPAIR OFF AIRCRAFT = \$ 54.30  
 FIELD SCRAP = \$ 119.20  
 FIELD RETIREMENT = \$ 37.70  
 DEPOT REPAIR = \$ 1173.60  
 DEPOT SCRAP = \$ 552.00  
 DEPOT RETIREMENT = \$ 334.50  
 TOTAL MAINTENANCE COST = \$ 2232.70

TOTAL LIFE-CYCLE BLADE COST PER AIRCRAFT \$44,017.60  
 =====

MAINTENANCE MAN-HOURS/FLIGHT HOUR = 0.0205  
 BLADE-RELATED AIRCRAFT DOWNTIME = 61 HOURS  
 =====

Reproduced from  
 best available copy.

HELICOPTER LIFE-CYCLE BLADE COSTS

CURRENT UH-1H MRB

NEW BLADE PRICE = \$ 3000  
 MEAN TIME BETWEEN FAILURES = 1200.0 BLADE HOURS  
 FIELD REPAIRABILITY = 12.4 PERCENT

MEAN TIME BETWEEN MAINTENANCE ACTIONS (BLADE HOURS):  
 REPLACEMENTS = 1235.7  
 REMOVALS FOR REPAIR OR REPLACEMENT = 1007.3  
 REPAIRS = 5450.0  
 DAMAGE REPLACEMENTS = 1533.8  
 UNSCHEDULED MAINTENANCE = 1200.0  
 SCHEDULED MAINTENANCE (RETIREMENT) = 6273.0  
 ALL MAINTENANCE ACTIONS = 1007.3

BLADE EVENTS PER AIRCRAFT LIFE CYCLE:  
 NUMBER LOST TO ATTRITION = 1.5000  
 NUMBER FATIGUE RETIRED UNDAAGED = 1.5941  
 NUMBER REPAIRED ON AIRCRAFT = 0.0000  
 NUMBER REPAIRED OFF AIRCRAFT IN FIELD = 1.0305  
 NUMBER SCRAPPED IN FIELD = 2.7590  
 NUMBER DAMAGED AND RETIRED IN FIELD = 0.0231  
 NUMBER REPAIRED AT DEPOT = 0.3044  
 NUMBER SCRAPPED AT DEPOT = 2.2772  
 NUMBER DAMAGED AND RETIRED AT DEPOT = 1.4391  
 TOTAL NUMBER DAMAGED AND NOT REPAIRED = 6.4985  
 TOTAL NUMBER ALL REPLACEMENTS = 8.0926

MAIN ROTOR BLADE COSTS PER AIRCRAFT LIFE CYCLE:

COST OF INITIAL PROCUREMENT:  
 NEW AIRCRAFT EQUIPPING COST = \$ 6000.00  
 SPARES COST, WITH CONTAINERS = \$ 2016.00  
 SPARE REPAIR MATERIALS = \$ 0.30  
 REPAIR SUPPORT EQUIPMENT = \$ 160.00  
 TOTAL INITIAL PROCUREMENT COST = \$ 8176.30

COST OF REPLACEMENT BLADES FOR THOSE LOST AND UNSERVICEABLE (INCLUDING  
 BLADE SHIPPING AND CONTAINER SHIPPING COSTS):  
 BLADES LOST TO ATTRITION = \$ 4762.50  
 DAMAGED BLADES NOT REPAIRED = 220373.20  
 TIME-EXPIRED UNDAAGED BLADES = \$ 5061.40  
 TOTAL REPLACEMENT COST = \$30202.10

COST OF MAINTENANCE ACTIONS (LABOR AND MATERIAL TO INSPECT, REMOVE,  
 REPAIR, REPLACE, ALIGN, AND TRACK):  
 FIELD REPAIR ON AIRCRAFT = \$ 0.00  
 FIELD REPAIR OFF AIRCRAFT = \$ 45.70  
 FIELD SCRAP = \$ 99.30  
 FIELD RETIREMENT = \$ 48.50  
 DEPOT REPAIR = \$ 982.20  
 DEPOT SCRAP = \$ 460.00  
 DEPOT RETIREMENT = \$ 232.10  
 TOTAL MAINTENANCE COST = \$ 1917.80

TOTAL LIFE-CYCLE BLADE COST PER AIRCRAFT \$40,276.10  
 =====

MAINTENANCE HOURS/FLIGHT HOUR = 0.0130  
 BLADE-RELATED AIRCRAFT DOWNTIME = 53 HOURS  
 =====

HELICOPTER LIFE-CYCLE BLADE COSTS

CURRENT UH-1H MRB MODEL NO CONTROL DAMAGE

NEW BLADE PRICE = \$ 3000  
 MEAN TIME BETWEEN FAILURES = 636.4 BLADE HOURS  
 FIELD RELIABILITY = 13.2 PERCENT

MEAN TIME BETWEEN MAINTENANCE ACTIONS (BLADE HOURS):  
 REMOVALS = 343.7  
 REMOVALS FOR REPAIR OR REPLACEMENT = 658.9  
 REPAIRS = 2331.3  
 DAMAGED REPLACEMENTS = 905.1  
 UNSCHEDULED MAINTENANCE = 676.4  
 SCHEDULED MAINTENANCE (RETIREMENT) = 13373.1  
 ALL MAINTENANCE ACTIONS = 652.9

BLADE EVENTS PER AIRCRAFT LIFE CYCLE:  
 NUMBER LOST TO ATTRITION = 1.5000  
 NUMBER FATIGUE CRACKED & DAMAGED = 0.7464  
 NUMBER REPAIRED IN AIRCRAFT = 0.0000  
 NUMBER REPAIRED OFF AIRCRAFT IN FIELD = 1.9177  
 NUMBER SCRAPPED IN FIELD = 4.6781  
 NUMBER DAMAGED AND RETIRED IN FIELD = 0.0406  
 NUMBER REPAIRED AT DEPOT = 1.6142  
 NUMBER SCRAPPED AT DEPOT = 3.7930  
 NUMBER DAMAGED AND RETIRED AT DEPOT = 2.5251  
 TOTAL NUMBER DAMAGED AND NOT REPAIRED = 11.0363  
 TOTAL NUMBER ALL REPLACEMENTS = 11.7832

MAIN ROTOR BLADE COSTS PER AIRCRAFT LIFE CYCLE:

COST OF INITIAL PROCUREMENT:  
 NEW AIRCRAFT OUTFITTING COST = \$ 6000.00  
 SPARES COST, WITH CONTAINERS = \$ 2016.00  
 SPARE REPAIR MATERIALS = \$ 0.50  
 REPAIR SUPPORT EQUIPMENT = \$ 160.00  
 TOTAL INITIAL PROCUREMENT COST = \$ 8176.50

COST OF REPLACEMENT BLADES FOR THOSE LOST AND UNSERVICEABLE (INCLUDING BLADE SHIPPING AND CONTAINER SHIPPING COSTS):  
 BLADES LOST TO ATTRITION = \$ 4762.50  
 DAMAGED BLADES NOT REPAIRED = \$ 35501.30  
 TIME-EXPIRED UN-DAMAGED BLADES = \$ 2369.70  
 TOTAL REPLACEMENT COST = \$ 42634.00

COST OF MAINTENANCE ACTIONS (LABOR AND MATERIAL TO INSPECT, REMOVE, REPAIR, REPLACE, ALIGN, AND TRACK):  
 FIELD REPAIR ON AIRCRAFT = \$ 0.00  
 FIELD REPAIR OFF AIRCRAFT = \$ 85.10  
 FIELD SCRAP = \$ 168.40  
 FIELD RETIREMENT = \$ 23.60  
 DEPOT REPAIR = \$ 1971.00  
 DEPOT SCRAP = \$ 766.20  
 DEPOT RETIREMENT = \$ 494.90  
 TOTAL MAINTENANCE COST = \$ 3509.20

TOTAL LIFE-CYCLE BLADE COST PER AIRCRAFT \$54,319.80  
 =====

MAINTENANCE MAN-HOURS/FLIGHT HOUR = 0.0279  
 BLADE-RELATED AIRCRAFT DOWNTIME = 33 HOURS  
 =====

HELICOPTER LIFE-CYCLE BLADE COSTS

CURRENT UH-1H MRB \*\*\*\*\* NO COMBAT DAMAGE

NEW BLADE PRICE = \$ 3000  
 MEAN TIME BETWEEN FAILURES = 1045.6 BLADE HOURS  
 FIELD REPAIRABILITY = 13.2 PERCENT

MEAN TIME BETWEEN MAINTENANCE ACTIONS (BLADE HOURS):  
 REPLACEMENTS = 1154.6  
 REMOVALS FOR REPAIR OR REPLACEMENT = 210.3  
 REPAIRS = 4313.0  
 DAMAGE REPLACEMENTS = 1330.2  
 UNSCHEDULED MAINTENANCE = 1045.6  
 SCHEDULED MAINTENANCE (RETIREMENT) = 7064.5  
 ALL MAINTENANCE ACTIONS = 910.8

BLADE EVENTS PER AIRCRAFT LIFE CYCLE:  
 NUMBER LOST TO ATTRITION = 1.5000  
 NUMBER FATIGUE RETIRED UNDAMAGED = 1.4155  
 NUMBER REPAIRED ON AIRCRAFT = 0.0000  
 NUMBER REPAIRED OFF AIRCRAFT IN FIELD = 1.2539  
 NUMBER SCRAPPED IN FIELD = 3.0709  
 NUMBER DAMAGED AND RETIRED IN FIELD = 0.0267  
 NUMBER REPAIRED AT DEPOT = 1.0597  
 NUMBER SCRAPPED AT DEPOT = 2.4899  
 NUMBER DAMAGED AND RETIRED AT DEPOT = 1.6576  
 TOTAL NUMBER DAMAGED AND NOT REPAIRED = 7.2452  
 TOTAL NUMBER ALL REPLACEMENTS = 8.6607

MAIN ROTOR BLADE COSTS PER AIRCRAFT LIFE CYCLE:

COST OF INITIAL PROCUREMENT:  
 NEW AIRCRAFT OUTFITTING COST = \$ 6000.00  
 SPARES COST, WITH CONTAINERS = \$ 2016.00  
 SPARE REPAIR MATERIALS = \$ 0.30  
 REPAIR SUPPORT EQUIPMENT = \$ 160.00  
 TOTAL INITIAL PROCUREMENT COST = \$ 3176.30

COST OF REPLACEMENT BLADES FOR THOSE LOST AND UNSERVICEABLE (INCLUDING  
 BLADE SHIPPING AND CONTAINER SHIPPING COSTS):  
 BLADES LOST TO ATTRITION = \$ 4762.50  
 DAMAGED BLADES NOT REPAIRED = \$22377.60  
 TIME-EXPIRED UNDAMAGED BLADES = \$ 4494.30  
 TOTAL REPLACEMENT COST = \$32136.40

COST OF MAINTENANCE ACTIONS (LABOR AND MATERIAL TO INSPECT, REMOVE,  
 REPAIR, REPLACE, ALIGN, AND TRACK):  
 FIELD REPAIR ON AIRCRAFT = \$ 0.00  
 FIELD REPAIR OFF AIRCRAFT = \$ 55.30  
 FIELD SCRAP = \$ 110.60  
 FIELD RETIREMENT = \$ 43.30  
 DEPOT REPAIR = \$ 1293.90  
 DEPOT SCRAP = \$ 503.00  
 DEPOT RETIREMENT = \$ 324.90  
 TOTAL MAINTENANCE COST = \$ 2331.40

TOTAL LIFE-CYCLE BLADE COST PER AIRCRAFT \$42,644.20  
 =====

MAINTENANCE MAN-HOURS/FLIGHT HOUR = 0.0200  
 BLADE-RELATED AIRCRAFT DOWNTIME = 59 HOURS  
 =====

HELICOPTER LIFE-CYCLE BLADE COSTS

CURRENT UH-1H MRB \*\*\*\*\* NO COMBAT DAMAGE

NEW BLADE PRICE = \$ 3000  
 MEAN TIME BETWEEN FAILURES = 1144.0 BLADE HOURS  
 FIELD REPAIRABILITY = 13.2 PERCENT

MEAN TIME BETWEEN MAINTENANCE ACTIONS (BLADE HOURS):  
 REPLACEMENTS = 1221.3  
 REMOVALS FOR REPAIR OR REPLACEMENT = 970.5  
 REPAIRS = 4725.3  
 DAMAGE REPLACEMENTS = 1507.4  
 UNSCHEDULED MAINTENANCE = 1144.0  
 SCHEDULED MAINTENANCE (RETIREMENT) = 6379.6  
 ALL MAINTENANCE ACTIONS = 970.5

BLADE EVENTS PER AIRCRAFT LIFE CYCLE:  
 NUMBER LOST TO ATTRITION = 1.5000  
 NUMBER FATIGUE RETIRED / DAMAGED = 1.5626  
 NUMBER REPAIRED ON AIRCRAFT = 0.0000  
 NUMBER RETIRED OFF AIRCRAFT IN FIELD = 1.1506  
 NUMBER SCRAPPED IN FIELD = 2.8055  
 NUMBER DAMAGED AND RETIRED IN FIELD = 0.0244  
 NUMBER REPAIRED AT DEPOT = 0.9654  
 NUMBER SCRAPPED AT DEPOT = 2.2793  
 NUMBER DAMAGED AND RETIRED AT DEPOT = 1.5155  
 TOTAL NUMBER DAMAGED AND NOT REPAIRED = 6.6252  
 TOTAL NUMBER ALL REPLACEMENTS = 3.1873

MAIN ROTOR BLADE COSTS PER AIRCRAFT LIFE CYCLE:

COST OF INITIAL PROCUREMENT:  
 NEW AIRCRAFT EQUIPPING COST = \$ 6000.00  
 SPARES COST, WITH CONTAINERS = \$ 2016.00  
 SPARE REPAIR MATERIALS = \$ 0.30  
 REPAIR SUPPORT EQUIPMENT = \$ 160.00  
 TOTAL INITIAL PROCUREMENT COST = \$ 3176.30

COST OF REPLACEMENT BLADES FOR THOSE LOST AND UNSERVICEABLE (INCLUDING  
 BLADE SHIPPING AND CONTAINER SHIPPING COSTS):  
 BLADES LOST TO ATTRITION = \$ 4762.50  
 DAMAGED BLADES NOT REPAIRED = \$20321.20  
 TIME-EXPIRED / DAMAGED BLADES = \$ 4761.20  
 TOTAL REPLACEMENT COST = \$30544.90

COST OF MAINTENANCE ACTIONS (LABOR AND MATERIAL TO INSPECT, REMOVE,  
 REPAIR, REPLACE, ALIGN, AND TRACK):  
 FIELD REPAIR ON AIRCRAFT = \$ 0.00  
 FIELD REPAIR OFF AIRCRAFT = \$ 51.00  
 FIELD SCRAP = \$ 101.00  
 FIELD RETIREMENT = \$ 47.60  
 DEPOT REPAIR = \$ 1173.30  
 DEPOT SCRAP = \$ 460.50  
 DEPOT RETIREMENT = \$ 227.00  
 TOTAL MAINTENANCE COST = \$ 2136.00

TOTAL LIFE-CYCLE BLADE COST PER AIRCRAFT \$40,857.20  
 =====

MAINTENANCE MAN-HOURS/FLIGHT HOUR = 0.0137  
 BLADE-RELATED AIRCRAFT DOWNTIME = 55 HOURS  
 =====

HELICOPTER LIFE-CYCLE BLADE COSTS

CURRENT UH-1H MIB \*\*\*\*\* NO COMBAT DAMAGE

NEW BLADE PRICE = \$ 3000  
 MEAN TIME BETWEEN FAILURES = 1372.3 BLADE HOURS  
 FIELD REPAIRABILITY = 13.2 PERCENT

MEAN TIME BETWEEN MAINTENANCE ACTIONS (BLADE HOURS):

REPLACEMENTS = 1356.0  
 ARRIVALS FOR REPAIR OR REPLACEMENT = 1094.0  
 REPAIRS = 5662.6  
 DAMAGE REPLACEMENTS = 1312.1  
 UNSCHEDULED MAINTENANCE = 1372.3  
 SCHEDULED MAINTENANCE (RETIREMENT) = 5238.0  
 ALL MAINTENANCE ACTIONS = 1094.0

BLADE EVENTS PER AIRCRAFT LIFE CYCLE:

NUMBER LOST TO ATTRITION = 1.5000  
 NUMBER FATIGUE RETIRED UN DAMAGED = 1.3560  
 NUMBER REPAIRED ON AIRCRAFT = 0.0000  
 NUMBER REPAIRED OFF AIRCRAFT IN FIELD = 0.9539  
 NUMBER SCRAPPED IN FIELD = 2.3390  
 NUMBER DAMAGED AND RETIRED IN FIELD = 0.0203  
 NUMBER REPAIRED AT DEPOT = 0.8071  
 NUMBER SCRAPPED AT DEPOT = 1.8965  
 NUMBER DAMAGED AND RETIRED AT DEPOT = 1.2626  
 TOTAL NUMBER DAMAGED AND NOT REPAIRED = 3.5184  
 TOTAL NUMBER ALL REPLACEMENTS = 7.3744

MAIN ROTOR BLADE COSTS PER AIRCRAFT LIFE CYCLE:

COST OF INITIAL PROCUREMENT:

NEW AIRCRAFT EQUIPPING COST = \$ 6000.00  
 SPARES COST, WITH CONTAINERS = \$ 2016.00  
 SPARE REPAIR MATERIALS = \$ 0.30  
 REPAIR SUPPORT EQUIPMENT = \$ 160.00  
 TOTAL INITIAL PROCUREMENT COST = \$ 3176.30

COST OF REPLACEMENT BLADES FOR THOSE LOST AND UNSERVICEABLE (INCLUDING BLADE SHIPPING AND CONTAINER SHIPPING COSTS):

BLADES LOST TO ATTRITION = \$ 4762.50  
 DAMAGED BLADES NOT REPAIRED = \$ 17199.20  
 TIME-EXPIRED OR DAMAGED BLADES = \$ 5921.70  
 TOTAL REPLACEMENT COST = \$ 27883.10

COST OF MAINTENANCE ACTIONS (LABOR AND MATERIAL TO INSPECT, REMOVE, REPAIR, REMOVE, ALIGN, AND TRACK):

FIELD REPAIR ON AIRCRAFT = \$ 0.00  
 FIELD REPAIR OFF AIRCRAFT = \$ 42.50  
 FIELD SCRAP = \$ 34.20  
 FIELD RETIREMENT = \$ 56.20  
 DEPOT REPAIR = \$ 938.50  
 DEPOT SCRAP = \$ 258.10  
 DEPOT RETIREMENT = \$ 247.50  
 TOTAL MAINTENANCE COST = \$ 1799.10

TOTAL LIFE-CYCLE BLADE COST PER AIRCRAFT = \$ 37,783.40  
 =====

MAINTENANCE MAN-HOURS/FLIGHT HOUR = 0.0126  
 TIME-RELATED AIRCRAFT DOWNTIME = 40 HOURS  
 =====

HELICOPTER LIFE-CYCLE BLADE COSTS

UH-1 HUB \*\*\*\*\* NO DEPOT \*\*\*\*\* WITH COMBAT DAMAGE

NEW BLADE PRICE = \$ 3000  
 MEAN TIME BETWEEN FAILURES = 214.0 BLADE HOURS  
 FIELD REPAIRABILITY = 12.4 PERCENT

MEAN TIME BETWEEN MAINTENANCE ACTIONS (BLADE HOURS):

REPLACEMENTS = 948.1  
 REMOVALS FOR REPAIR OR REPLACEMENT = 840.3  
 REPAIRS = 7391.5  
 DAMAGE REPLACEMENTS = 1043.0  
 UNSCHEDULED MAINTENANCE = 914.0  
 SCHEDULED MAINTENANCE (RETIREMENT) = 10419.5  
 ALL MAINTENANCE ACTIONS = 840.3

BLADE EVENTS PER AIRCRAFT LIFE CYCLE:

NUMBER LOST TO ATTRITION = 1.5000  
 NUMBER FATIGUE RETIRED/DAMAGED = 0.9597  
 NUMBER REPAIRED ON AIRCRAFT = 0.0000  
 NUMBER REPAIRED OFF AIRCRAFT IN FIELD = 1.3529  
 NUMBER SCRAPPED IN FIELD = 2.5577  
 NUMBER DAMAGED AND RETIRED IN FIELD = 0.0304  
 TOTAL NUMBER DAMAGED AND NOT REPAIRED = 9.5330  
 TOTAL NUMBER ALL REPLACEMENTS = 10.5473

MAIN ROTOR BLADE COSTS PER AIRCRAFT LIFE CYCLE:

COST OF INITIAL PROCUREMENT:

NEW AIRCRAFT OUTFITTING COST = \$ 6000.00  
 SPARES COST, WITH CONTAINERS = \$ 2016.00  
 SPARE REPAIR MATERIALS = \$ 0.40  
 REPAIR SUPPORT EQUIPMENT = \$ 160.00  
 TOTAL INITIAL PROCUREMENT COST = \$ 8176.40

COST OF REPLACEMENT BLADES FOR THOSE LOST AND UNSERVICEABLE (INCLUDING BLADE SHIPPING AND CONTAINER SHIPPING COSTS):

BLADES LOST TO ATTRITION = \$ 4762.50  
 DAMAGED BLADES NOT REPAIRED = \$ 30442.50  
 TIME-EXPIRED UNREPAIRED BLADES = \$ 3047.20  
 TOTAL REPLACEMENT COST = \$ 38252.20

COST OF MAINTENANCE ACTIONS (LABOR AND MATERIAL TO INSPECT, REMOVE, REPAIR, REPLACE, ALIGN, AND TRACK):

FIELD REPAIR ON AIRCRAFT = \$ 0.00  
 FIELD REPAIR OFF AIRCRAFT = \$ 60.00  
 FIELD SCRAP = \$ 344.10  
 FIELD RETIREMENT = \$ 29.70  
 TOTAL MAINTENANCE COST = \$ 433.80

TOTAL LIFE-CYCLE BLADE COST PER AIRCRAFT \$46,869.30

MAINTENANCE MAN-HOURS/FLIGHT HOUR = 0.0216  
 BLADE-RELATED AIRCRAFT DOWNTIME = 64 HOURS  
 =====

HELICOPTER LIFE-CYCLE BLADE COSTS

UH-1H AND H-19 NO DEPOT & NO COMBAT DAMAGE

NEW BLADE PRICE = 5 3000  
 MEAN TIME BETWEEN FAILURES = 1045.5 BLADE HOURS  
 FIELD MAINTAINABILITY = 13.5 PERCENT

MEAN TIME BETWEEN MAINTENANCE ACTIONS (BLADE HOURS):

REPLACEMENT = 1051.4  
 REMOVE FOR REPAIR OR REPLACEMENT = 930.2  
 REPAIR = 3066.7  
 DAMAGE REPLACEMENTS = 1201.4  
 UNSCHEDULED MAINTENANCE = 1045.6  
 SCHEDULED MAINTENANCE (RETIREMENT) = 3424.3  
 ALL MAINTENANCE ACTIONS = 930.2

BLADE EVENTS PER AIRCRAFT LIFE CYCLE:

NUMBER LOST TO ATTRITION = 1.5000  
 NUMBER OF BLADES RETIRED UNDAMAGED = 1.1370  
 NUMBER REPAIRED ON AIRCRAFT = 0.0000  
 NUMBER REPAIRED OFF AIRCRAFT IN FIELD = 1.2393  
 NUMBER DAMAGED IN FIELD = 3.2973  
 NUMBER DAMAGED AND RETIRED IN FIELD = 0.0267  
 TOTAL NUMBER DAMAGED AND NOT RETAINED = 3.3239  
 TOTAL NUMBER ALL REPLACEMENTS = 2.5110

MAIN ROTOR BLADE COSTS PER AIRCRAFT LIFE CYCLE:

COST OF INITIAL PROCUREMENT:

NEW AIRCRAFT EQUIPPING COST = \$ 6000.00  
 SPARES CRIT, WITH CONTAINERS = \$ 2016.00  
 SPARE REPAIR MATERIALS = \$ 0.30  
 REPAIR SUPPORT EQUIPMENT = \$ 160.00  
 TOTAL INITIAL PROCUREMENT COST = \$ 8176.30

COST OF REPLACEMENT BLADES FOR THOSE LOST AND UNSERVICEABLE (INCLUDING BLADE SHIPPING AND CONTAINER SHIPPING COSTS):

BLADES LOST TO ATTRITION = \$ 4762.50  
 DAMAGED BLADES NOT REPAIRED = 126271.40  
 TIME-EXPIRED/DAMAGED BLADES = \$ 3764.90  
 TOTAL REPLACEMENT COST = \$34302.80

COST OF MAINTENANCE ACTIONS (LABOR AND MATERIAL TO INSPECT, REMOVE, REPAIR, REPLACE, ALIGN, AND TRACK):

FIELD REPAIR ON AIRCRAFT = \$ 0.00  
 FIELD REPAIR OFF AIRCRAFT = \$ 55.00  
 FIELD SCRAP = \$ 291.70  
 FIELD RETIREMENT = \$ 36.40  
 TOTAL MAINTENANCE COST = \$ 390.10

TOTAL LIFE-CYCLE BLADE COST PER AIRCRAFT \$43,369.30

MAINTENANCE MAN-HOUR/FLIGHT HOUR = 0.0126  
 BLADE-RELATED AIRCRAFT DOWNTIME = 53 HOURS

HELICOPTER LIFE-CYCLE BLADE COSTS

FIELD REPAIR, TELETYPE/TYPE DESIGN 1

100 BLADE PRICE = \$ 2315  
 756.6 BLADE HOURS  
 FIELD RELIABILITY = 61.2 PERCENT

MAN TIME REQUIRED FOR MAINTENANCE ACTIVITY (BLADE HOURS):

APPROACHING = 1406.7  
 REPAIR OR REPLACEMENT (REPLACEMENT) = 1361.5  
 REMOVAL = 1235.5  
 DAMAGE TO BLADES = 1244.5  
 INITIAL CHECKS AND INSPECTIONS = 756.6  
 SCHEDULED MAINTENANCE (RETIREMENT) = 5637.3  
 ALL OTHER MAINTENANCE ACTIVITIES = 553.7

FIELD REPAIRS AND MAINTENANCE IN LINE CYCLE:

NUMBER OF BLADES DAMAGED = 1.9500  
 NUMBER OF BLADES REPAIRED IN FIELD = 1.9800  
 NUMBER OF BLADES REPLACED IN AIRCRAFT = 7.3200  
 NUMBER OF BLADES DAMAGED IN FIELD = 9.2300  
 NUMBER DAMAGED AND REPAIRED IN FIELD = 5.1100  
 NUMBER DAMAGED AND REPLACED IN FIELD = 9.0200  
 TOTAL NUMBER OF BLADES NOT REPAIRED = 5.1900  
 TOTAL COST OF ALL REPAIRS = 7.1073

MAIN ENGINE BLADE COSTS PER AIRCRAFT LIFE CYCLE:

COST OF INITIAL INSPECTION = 1.0000  
 COST OF INITIAL INSPECTION COST = 1.0000  
 CHARGES FOR REPAIRS AND INSPECTIONS = 1.9300  
 COST OF MAINTENANCE IN FIELD = 5.1170  
 REPAIRS AND REPLACEMENTS IN FIELD = 5.1600  
 TOTAL INITIAL INSPECTION COST = 5.1726.70

COST OF MAINTENANCE AND REPAIRS FOR HELICOPTER UNDERVARIABLES (INCLUDING BLADES) PER AIRCRAFT LIFE CYCLE:

MAINTENANCE AND REPAIRS IN FIELD = 1.0000  
 MAINTENANCE AND REPAIRS IN AIRCRAFT = 1.9300  
 MAINTENANCE AND REPAIRS IN FIELD = 5.1170  
 TOTAL MAINTENANCE AND REPAIRS COST = 8.0470

COST OF MAINTENANCE AND REPAIRS FOR AIRCRAFT AND MATERIAL TO INSPECT, REPAIR, AND REPLACE:

FIELD REPAIRS AND MAINTENANCE IN AIRCRAFT = 7.3200  
 FIELD REPAIRS AND MAINTENANCE IN AIRCRAFT = 11.40  
 FIELD REPAIRS AND MAINTENANCE IN AIRCRAFT = 144.30  
 FIELD REPAIRS AND MAINTENANCE IN AIRCRAFT = 1.0000  
 TOTAL MAINTENANCE AND REPAIRS COST = 163.02

TOTAL LIFE-CYCLE COST PER AIRCRAFT = 163.02

PERCENTAGE OF COSTS IN FIELD = 6.1140  
 PERCENTAGE OF COSTS IN AIRCRAFT = 16.8120

HELICOPTER LIFE-CYCLE BLADE COSTS

FIELD MAINTAINABLE/REPAIRABLE BLADE DESIGN 1

NEW BLADE PRICE = \$ 2310  
 NATIONAL AIRCRAFT FACTORY = 1251.0 BLADE PRICE  
 FIELD MAINTAINABILITY = 61.2 PERCENT

MEAN TIME BETWEEN MAINTENANCE ACTIONS (BLADE YEARS):

LOSS TO LIFE = 1755.2  
 LOSS TO LIFE BY REPLACEMENT = 1713.2  
 REPAIRS = 2957.1  
 BY REPLACEMENT = 3247.1  
 UNREPAIRABLE DAMAGE = 1261.0  
 LOSS TO LIFE BY RETIREMENT = 5073.0  
 ALL MAINTENANCE ACTIONS = 1007.0

BLADE EVENTS PER AIRCRAFT LIFE CYCLE:

NUMBER LOST TO FATIGUE = 1.5000  
 NUMBER FATIGUE DAMAGED UNREPAIRED = 2.0000  
 NUMBER REPAIRED = 4.7034  
 NUMBER REPAIRED PER AIRCRAFT IN FIELD = 0.1412  
 NUMBER DAMAGED IN FIELD = 3.0714  
 NUMBER DAMAGED AND REPAIRED IN FIELD = 0.0143  
 TOTAL NUMBER DAMAGED AND NOT REPAIRED = 3.0357  
 TOTAL NUMBER ALL REPLACEMENTS = 5.0357

MAIN ROTOR BLADE COST PER AIRCRAFT LIFE CYCLE:

COST OF INITIAL PROCUREMENT:

NEW AIRCRAFT QUANTITY COST = \$ 5620.00  
 SPARE COSTS, INITIAL TRAINING = \$ 1295.00  
 SPARE REPAIR MATERIALS = \$ 17.00  
 REPAIR SUPPORT EQUIPMENT = \$ 160.00  
 TOTAL INITIAL PROCUREMENT COST = \$ 7714.00

COST OF REPLACEMENT BLADES FOR FUEL LOST AND UNSERVICEABLE (INCLUDING BLADE SHIPPING AND CONTAINER SHIPPING COSTS):

BLADES LOST TO FATIGUE = \$ 4435.00  
 DAMAGED BLADES NOT REPAIRED = \$ 3416.70  
 TIME-REQUIRED DAMAGED BLADES = \$ 5990.00  
 TOTAL REPLACEMENT COST = \$ 13841.70

COST OF MAINTENANCE ACTIONS (LABOR AND MATERIAL TO INSPECT, REMOVE, REPAIR, REPLACE, OILING, AND TRACK):

FIELD WORK PER AIRCRAFT = \$ 353.30  
 FIELD WORK PER OFF AIRCRAFT = \$ 6.30  
 FIELD OILING = \$ 110.60  
 FIELD OILING = \$ 60.40  
 TOTAL MAINTENANCE COST = \$ 566.70

TOTAL LIFE-CYCLE BLADE COST PER AIRCRAFT 227,162.40  
 =====

MAINTENANCE NON-AVAILABILITY PER HOUR = 0.0116  
 BLADE-RELATED AIRCRAFT DOWNTIME = 42 HOURS  
 =====

HELICOPTER LIFE-CYCLE BLADE COSTS

FIELD AND AIRCRAFT/EXCHANGEABLE BLADE DESIGN 2

NEW BLADE PRICE = 2 233  
 MEAN TIME BETWEEN FAILURES = 756.6 BLADE HOURS  
 FIELD AVAILABILITY = 61.2 PERCENT

MEAN TIME BETWEEN MAINTENANCE ACTIONS (BLADE HOURS):  
 REPLACEMENT = 1407.0  
 ACTIONS FOR REPAIR OR REPLACEMENT = 1351.3  
 REPAIR = 1233.4  
 DAMAGE REPLACEMENT = 1244.6  
 UNCONTROLLED MAINTENANCE = 756.6  
 SCHEDULED MAINTENANCE (RETIREMENT) = 3033.7  
 ALL MAINTENANCE ACTIONS = 653.7

BLADE EVENTS PER AIRCRAFT LIFE CYCLE:  
 NUMBER LOST TO ATTRITION = 1.5000  
 NUMBER FATIGUE DAMAGED UNREPAIRED = 1.9651  
 NUMBER REPAIRED ON AIRCRAFT = 7.3390  
 NUMBER REPAIRED OFF AIRCRAFT IN FIELD = 0.2357  
 NUMBER SCRAPPED IN FIELD = 5.1192  
 NUMBER DAMAGED AND RETIRED IN FIELD = 0.0232  
 TOTAL NUMBER DAMAGED AND NOT REPAIRED = 5.1424  
 TOTAL NUMBER ALL REPLACEMENTS = 7.1075

MAIN ROIN BLADE COSTS PER AIRCRAFT LIFE CYCLE:

COST OF INITIAL PROCUREMENT:  
 NEW AIRCRAFT PROCUREMENT COST = \$ 5776.00  
 SPARE COST, WITH CONTAINERS = \$ 1943.30  
 SPARE REPAIR MATERIALS = \$ 31.70  
 REPAIR SUPPORT EQUIPMENT = \$ 160.00  
 TOTAL INITIAL PROCUREMENT COST = \$ 7716.50

COST OF REPLACEMENT BLADES FOR THOSE LOST AND UNSERVICEABLE (INCLUDING  
 BLADE SHIPPING AND CONTAINER SHIPPING COSTS):  
 BLADES LOST TO ATTRITION = \$ 4524.50  
 DAMAGED BLADES NOT REPAIRED = \$15231.60  
 TIME-EXPIRED UNREPAIRED BLADES = \$ 6019.20  
 TOTAL REPLACEMENT COST = \$25745.20

COST OF MAINTENANCE ACTIONS (LABOR AND MATERIAL TO INSPECT, REMOVE,  
 REPAIR, REPLACE, ALIGN, AND TRACK):  
 FIELD REPAIR ON AIRCRAFT = \$ 643.00  
 FIELD REPAIR OFF AIRCRAFT = \$ 11.40  
 FIELD SCRAP = \$ 134.30  
 FIELD RETIREMENT = \$ 59.60  
 TOTAL MAINTENANCE COST = \$ 903.40

TOTAL LIFE-CYCLE BLADE COST PER AIRCRAFT \$34,665.20  
 =====

MAINTENANCE MAN-HOURS/FLIGHT HOUR = 0.0167  
 BLADE-RELATED AIRCRAFT DOWNTIME = 63 HOURS  
 =====

HELICOPTER LIFE-CYCLE BLADE COSTS

FIELD REPAIRABLE/EXPENDABLE BLADE DESIGN 2

NET BLADE PRICE = \$ 2338  
 MEAN TIME BETWEEN FAILURES = 1261.0 BLADE HOURS  
 FIELD MAINTAINABILITY = 61.2 PERCENT

MEAN TIME BETWEEN MAINTENANCE ACTIONS (BLADE HOURS):

REPLENISHMENT = 1266.4  
 REPAIRS FOR MINOR REPLACEMENT = 1713.2  
 REPAIRS = 2064.1  
 DAMAGE REPLACEMENTS = 3241.0  
 UNRECORDED MAINTENANCE = 1241.0  
 SCHEDULED MAINTENANCE (RETIREMENT) = 5000.0  
 ALL MAINTENANCE ACTIONS = 1007.0

BLADE EVENTS PER AIRCRAFT LIFE CYCLE:

NUMBER LOST TO FATIGUE = 1.5000  
 NUMBER FATIGUE DAMAGED/DAMAGED = 2.0000  
 NUMBER REPAIRED ON AIRCRAFT = 4.7034  
 NUMBER REPAIRED OFF AIRCRAFT IN FIELD = 5.1414  
 NUMBER SCRAPPED IN FIELD = 3.0715  
 NUMBER DAMAGED AND REPAIRED IN FIELD = 0.7132  
 TOTAL NUMBER DAMAGED AND NOT REPAIRED =  
 TOTAL NUMBER ALL REPLACEMENTS

MAIN ROTOR BLADE COSTS PER AIRCRAFT LIFE CYCLE:

COST OF INITIAL PROCUREMENT:

NEW AIRCRAFT EQUIPPING COST = \$ 5776.00  
 SPARES COST, WITH CONTAINERS = \$ 1943.70  
 SPARE REPAIR MATERIALS = \$ 19.00  
 REPAIR SUPPORT EQUIPMENT = \$ 160.00  
 TOTAL INITIAL PROCUREMENT COST = \$ 7903.30

COST OF REPLACEMENT BLADES FOR TIME LOST AND UNSERVICEABLE (INCLUDING BLADE SHIPPING AND CONTAINER SHIPPING COSTS):

BLADES LOST TO FATIGUE = \$ 4574.50  
 DAMAGED BLADES NOT REPAIRED = \$ 3621.40  
 TIME-DAMAGED/DAMAGED BLADES = \$ 6126.00  
 TOTAL REPLACEMENT COST = \$13321.90

COST OF MAINTENANCE ACTIONS (LABOR AND MATERIAL TO INSPECT, REMOVE, REPAIR, REPLACE, ALIGN, AND TRACK):

FIELD REPAIR ON AIRCRAFT = \$ 335.30  
 FIELD REPAIR OFF AIRCRAFT = \$ 6.30  
 FIELD SCRAP = \$ 110.50  
 FIELD RETIREMENT = \$ 60.40  
 TOTAL MAINTENANCE COST = \$ 566.70

TOTAL LIFE-CYCLE BLADE COST PER AIRCRAFT \$27,312.40  
 =====

MAINTENANCE MAN-HOURS/FLIGHT HOUR = 0.0116  
 BLADE-RELATED AIRCRAFT DOWNTIME = 42 HOURS  
 =====

HELICOPTER LIFE-CYCLE BLADE COSTS

FIELD REPAIRABLE/DEPENDABLE BLADE DESIGN 3

NEW BLADE PRICE = \$ 3765  
 MEAN TIME BETWEEN FAILURES = 777.0 BLADE HOURS  
 FIELD REPAIRABILITY = 49.5 PERCENT

MEAN TIME BETWEEN MAINTENANCE ACTIONS (BLADE HOURS):

REPLACEMENT = 1634.3  
 REMOVAL FOR REPAIR OR REPLACEMENT = 1287.4  
 REPAIR = 1572.4  
 DAMAGE REPLACEMENTS = 1538.0  
 UNSCHEDULED MAINTENANCE = 777.0  
 SCHEDULED MAINTENANCE (RETIREMENT) = 6214.7  
 ALL MAINTENANCE ACTIONS = 591.5

BLADE EVENTS PER AIRCRAFT LIFE CYCLE:

NUMBER LOST TO AIRCRAFT = 1.5000  
 NUMBER REPAIRABLE/REPAIRABLE/DAMAGED = 1.5914  
 NUMBER REMOVED TO AIRCRAFT = 6.3101  
 NUMBER REPAIRED PER AIRCRAFT IN FIELD = 0.6456  
 NUMBER SCRAMMED IN FIELD = 6.4542  
 NUMBER SCRAMMED AND REPAIRED IN FIELD = 0.0002  
 TOTAL NUMBER DAMAGED AND NOT REPAIRED = 6.5103  
 TOTAL NUMBER ALL REPLACEMENTS = 8.1013

MAINTENANCE BLADE COSTS PER AIRCRAFT LIFE CYCLE:

COST OF INITIAL PROCUREMENT:

NEW AIRCRAFT IDENTIFICATION COST = \$ 7520.00  
 SPARE PARTS, WITH CONTINGENCY = \$ 2475.00  
 SPARE REPAIR MATERIALS = \$ 26.40  
 REPAIR SUPPLIES/TOOLS, ETC = \$ 160.00  
 TOTAL INITIAL PROCUREMENT COST = \$10191.40

COST OF REPLACEMENT BLADES FOR THOSE LOST AND UNSERVICEABLE (INCLUDING

BLADE SHIPPING AND CONTAINER SHIPPING COSTS):  
 BLADES LOST TO AIRCRAFT = \$ 5910.00  
 DAMAGED BLADES NOT REPAIRED = \$25178.20  
 TIME-EXPIRED UNREPAIRED BLADES = \$ 6269.20  
 TOTAL REPLACEMENT COST = \$37357.40

COST OF MAINTENANCE ACTIONS (LABOR AND MATERIAL TO INSPECT, REMOVE,

REPAIR, REPLACE, ALIGN, AND TRACK):  
 FIELD REPAIR PER AIRCRAFT = \$ 540.20  
 FIELD SCRAM PER AIRCRAFT = \$ 2.20  
 FIELD SCRAM = \$ 283.50  
 FIELD REPAIR COST = \$ 48.40  
 TOTAL MAINTENANCE COST = \$ 874.40

TOTAL LIFE-CYCLE BLADE COST PER AIRCRAFT \$46,373.20  
 =====

MAINTENANCE MAN-HOURS/FLIGHT HOUR = 0.0177  
 BLADE-RELATED AIRCRAFT DOWNTIME = 62 HOURS  
 =====

HELICOPTER LIFE-CYCLE BLADE COSTS

FIELD REPAIRABLE/EXPENDABLE BLADE DESIGN 3

NEW BLADE PRICE = \$ 3765  
 MEAN TIME BETWEEN FAILURES = 1295.0 BLADE HOURS  
 FIELD REPAIRABILITY = 49.5 PERCENT

MEAN TIME BETWEEN MAINTENANCE ACTIONS (BLADE HOURS):  
 REPLACEMENTS = 1693.1  
 REMOVE FOR REPAIR OR REPLACEMENT = 1635.3  
 REPAIRS = 2620.7  
 DAMAGE REPLACEMENTS = 2560.0  
 UNSCHEDULED MAINTENANCE = 1295.0  
 SCHEDULED MAINTENANCE (RETIREMENT) = 5000.0  
 ALL MAINTENANCE ACTIONS = 1023.6

BLADE EVENTS PER AIRCRAFT LIFE CYCLE:  
 NUMBER LOST TO ATTRITION = 1.5000  
 NUMBER FATIGUE RETIRED UNDAMAGED = 2.0000  
 NUMBER REPAIRED ON AIRCRAFT = 3.7834  
 NUMBER REPAIRED OFF AIRCRAFT IN FIELD = 0.0274  
 NUMBER SCRAPPED IN FIELD = 3.3229  
 NUMBER DAMAGED AND RETIRED IN FIELD = 0.0133  
 TOTAL NUMBER DAMAGED AND NOT REPAIRED = 3.9062  
 TOTAL NUMBER ALL REPLACEMENTS = 5.9062

MAIN ROTOR BLADE COSTS PER AIRCRAFT LIFE CYCLE:

COST OF INITIAL PROCUREMENT:  
 NEW AIRCRAFT OUTFITTING COST = \$ 7530.00  
 SPARES COST, WITH CONTAINERS = \$ 2475.00  
 SPARE REPAIR MATERIALS = \$ 15.90  
 REPAIR SUPPORT EQUIPMENT = \$ 160.00  
 TOTAL INITIAL PROCUREMENT COST = \$10130.90

COST OF REPLACEMENT BLADES FOR THOSE LOST AND UNSERVICEABLE (INCLUDING  
 BLADE SHIPPING AND CONTAINER SHIPPING COSTS):  
 BLADES LOST TO ATTRITION = \$ 5910.00  
 DAMAGED BLADES NOT REPAIRED = \$14435.40  
 TIME-EXPIRED UNDAMAGED BLADES = \$ 7830.00  
 TOTAL REPLACEMENT COST = \$23275.40

COST OF MAINTENANCE ACTIONS (LABOR AND MATERIAL TO INSPECT, REMOVE,  
 REPAIR, REPLACE, ALIGN, AND TRACK):  
 FIELD REPAIR ON AIRCRAFT = \$ 324.10  
 FIELD REPAIR OFF AIRCRAFT = \$ 1.30  
 FIELD SCRAP = \$ 140.10  
 FIELD RETIREMENT = \$ 60.40  
 TOTAL MAINTENANCE COST = \$ 526.00

TOTAL LIFE-CYCLE BLADE COST PER AIRCRAFT \$33,932.30  
 =====

MAINT'NCE MAN-HOURS/FLIGHT HOUR = 0.0125  
 BLADE-RELATED AIRCRAFT DOWNTIME = 43 HOURS  
 =====

Reproduced from  
best available copy.

HELICOPTER LIFE-CYCLE BLADE COSTS

FIELD REPAIRABLE/EXPENDABLE BLADE DESIGN 4

NEW BLADE PRICE = \$ 333  
 MEAN TIME BETWEEN FAILURES = 762.2 BLADE HOURS  
 FIELD REPAIRABILITY = 51.5 PERCENT

MEAN TIME BETWEEN MAINTENANCE ACTIONS (BLADE HOURS):

REPLACEMENTS = 1256.3  
 REMOVALS FOR REPAIR OR REPLACEMENT = 1247.5  
 REPAIRS = 1476.0  
 DAMAGE REPLACEMENTS = 1533.3  
 UNSCHEDULED MAINTENANCE = 762.2  
 SCHEDULED MAINTENANCE (RETIREMENT) = 3075.9  
 ALL MAINTENANCE ACTIONS = 653.0

BLADE EVENTS PER AIRCRAFT LIFE CYCLE:

NUMBER LOST TO ATTRITION = 1.5000  
 NUMBER FATIGUE RETIRED UN DAMAGED = 1.6404  
 NUMBER REPAIRED ON AIRCRAFT = 6.6331  
 NUMBER REPAIRED OFF AIRCRAFT IN FIELD = 0.0463  
 NUMBER SCRAPPED IN FIELD = 6.2950  
 NUMBER DAMAGED AND RETIRED IN FIELD = 0.0211  
 TOTAL NUMBER DAMAGED AND NOT REPAIRED = 6.3161  
 TOTAL NUMBER ALL REPLACEMENTS = 7.9566

MAIN ROTOR BLADE COSTS PER AIRCRAFT LIFE CYCLE:

COST OF INITIAL PROCUREMENT:

NEW AIRCRAFT OUTFITTING COST = \$ 7673.00  
 SPARE COST, WITH CONTAINERS = \$ 2519.40  
 SPARE REPAIR MATERIALS = \$ 23.30  
 REPAIR SUPPORT EQUIPMENT = \$ 160.00  
 TOTAL INITIAL PROCUREMENT COST = \$10355.70

COST OF REPLACEMENT BLADES FOR THOSE LOST AND UNSERVICEABLE (INCLUDING BLADE SHIPPING AND CONTAINER SHIPPING COSTS):

BLADES LOST TO ATTRITION = \$ 6021.00  
 DAMAGED BLADES NOT REPAIRED = \$24342.40  
 TIME-EXPIRED UNREPAIRED BLADES = \$ 6534.70  
 TOTAL REPLACEMENT COST = \$37443.20

COST OF MAINTENANCE ACTIONS (LABOR AND MATERIAL TO INSPECT, REMOVE, REPAIR, REPLACE, ALIGN, AND TRACK):

FIELD REPAIR ON AIRCRAFT = \$ 576.60  
 FIELD REPAIR OFF AIRCRAFT = \$ 2.30  
 FIELD SCRAP = \$ 226.60  
 FIELD RETIREMENT = \$ 49.30  
 TOTAL MAINTENANCE COST = \$ 855.30

TOTAL LIFE-CYCLE BLADE COST PER AIRCRAFT \$43,639.10  
 =====

MAINT'NCE MAN-HOURS/FLIGHT HOUR = 0.0176  
 BLADE-RELATED AIRCRAFT DOWNTIME = 63 HOURS  
 =====

HELICOPTER LIFE-CYCLE BLADE COSTS

FIELD REPAIRABLE/EXPENDABLE BLADE DESIGN 4

NEW BLADE PRICE = \$ 3339  
 DOWN TIME FROM FAILURES = 1232.0 BLADE HOURS  
 FIELD REPAIRABILITY = 51.5 PERCENT

MEASUREMENT BETWEEN MAINTENANCE ACTIONS (BLADE HOURS):

REPLACEMENTS = 1727.2  
 REMOVAL FOR REPAIR OR REPLACEMENT = 1719.0  
 REPAIRS = 2493.4  
 DAMAGE REPLACEMENTS = 2633.3  
 UNSCHEDULED MAINTENANCE = 1232.0  
 SCHEDULED MAINTENANCE (RETIREMENT) = 5000.0  
 ALL MAINTENANCE ACTIONS = 1020.4

BLADE EVENTS PER AIRCRAFT LIFE CYCLE:

NUMBER LOST TO ATTRITION = 1.5000  
 NUMBER FATIGUE RETIRED UN-DAMAGED = 2.0000  
 NUMBER REPAIRED ON AIRCRAFT = 3.9323  
 NUMBER REPAIRED OFF AIRCRAFT IN FIELD = 0.0278  
 NUMBER SCRAPPED IN FIELD = 3.7770  
 NUMBER DAMAGED AND RETIRED IN FIELD = 0.0127  
 TOTAL NUMBER DAMAGED AND NOT REPAIRED = 3.7397  
 TOTAL NUMBER ALL REPLACEMENTS = 5.7897

MAIN ROTOR BLADE COSTS PER AIRCRAFT LIFE CYCLE:

COST OF INITIAL PROCUREMENT:

NEW AIRCRAFT OUTFITTING COST = \$ 7578.00  
 SPARES COST, WITH CONTAINERS = \$ 2519.40  
 SPARE REPAIR MATERIALS = \$ 17.00  
 REPAIR SUPPORT EQUIPMENT = \$ 160.00  
 TOTAL INITIAL PROCUREMENT COST = \$10374.40

COST OF REPLACEMENT BLADES FOR THOSE LOST AND UNSERVICEABLE (INCLUDING BLADE SHIPPING AND CONTAINER SHIPPING COSTS):

BLADES LOST TO ATTRITION = \$ 6031.00  
 DAMAGED BLADES NOT REPAIRED = \$14266.40  
 TIME-EXPIRED UN-DAMAGED BLADES = \$ 8023.00  
 TOTAL REPLACEMENT COST = \$28319.40

COST OF MAINTENANCE ACTIONS (LABOR AND MATERIAL TO INSPECT, REMOVE, REPAIR, REPLACE, ALIGN, AND TRACK):

FIELD REPAIR ON AIRCRAFT = \$ 345.90  
 FIELD REPAIR OFF AIRCRAFT = \$ 1.40  
 FIELD SCRAP = \$ 136.00  
 FIELD RETIREMENT = \$ 50.40  
 TOTAL MAINTENANCE COST = \$ 543.70

TOTAL LIFE-CYCLE BLADE COST PER AIRCRAFT 339,233.40  
 =====

MAINTENANCE MAN-HOURS/FLIGHT HOUR = 0.0124  
 BLADE-RELATED AIRCRAFT DOWNTIME = 43 HOURS  
 =====

HELICOPTER LIFE-CYCLE BLADE COSTS

FIELD REPAIRABLE/EXPENDABLE BLADE DESIGN 5

NEW BLADE PRICE = \$ 3531  
 MEAN TIME BETWEEN FAILURES = 777.0 BLADE HOURS  
 FIELD REPAIRABILITY = 49.5 PERCENT

MEAN TIME BETWEEN MAINTENANCE ACTIONS (BLADE HOURS):

REPLACEMENTS = 1234.3  
 REMOVALS FOR REPAIR OR REPLACEMENT = 1227.5  
 REPAIRS = 1572.5  
 DAMAGE REPLACEMENTS = 1535.9  
 UNSCHEDULED MAINTENANCE = 777.0  
 SCHEDULED MAINTENANCE (RETIREMENT) = 6235.3  
 ALL MAINTENANCE ACTIONS = 691.5

BLADE EVENTS PER AIRCRAFT LIFE CYCLE:

NUMBER LOST TO ATTRITION = 1.5000  
 NUMBER FATIGUE RETIRED UNDAMAGED = 1.5310  
 NUMBER REPAIRED ON AIRCRAFT = 6.3141  
 NUMBER REPAIRED OFF AIRCRAFT IN FIELD = 0.0450  
 NUMBER SCRAPPED IN FIELD = 6.4876  
 NUMBER DAMAGED AND RETIRED IN FIELD = 0.0233  
 TOTAL NUMBER DAMAGED AND NOT REPAIRED = 6.5109  
 TOTAL NUMBER ALL REPLACEMENTS = 8.1019

MAIN ROTOR BLADE COSTS PER AIRCRAFT LIFE CYCLE:

COST OF INITIAL PROCUREMENT:

NEW AIRCRAFT OUTFITTING COST = \$ 7162.00  
 SPARES COST, WITH CONTAINERS = \$ 2364.60  
 SPARE REPAIR MATERIALS = \$ 26.40  
 REPAIR SUPPORT EQUIPMENT = \$ 160.00  
 TOTAL INITIAL PROCUREMENT COST = \$ 9713.00

COST OF REPLACEMENT BLADES FOR THOSE LOST AND UNSERVICEABLE (INCLUDING BLADE SHIPPING AND CONTAINER SHIPPING COSTS):

BLADES LOST TO ATTRITION = \$ 5634.00  
 DAMAGED BLADES NOT REPAIRED = \$24004.60  
 TIME-EXPIRED UNDAMAGED BLADES = \$ 5975.90  
 TOTAL REPLACEMENT COST = \$35614.50

COST OF MAINTENANCE ACTIONS (LABOR AND MATERIAL TO INSPECT, REMOVE, REPAIR, REPLACE, ALIGN, AND TRACK):

FIELD REPAIR ON AIRCRAFT = \$ 540.20  
 FIELD REPAIR OFF AIRCRAFT = \$ 2.20  
 FIELD SCRAP = \$ 233.60  
 FIELD RETIREMENT = \$ 48.40  
 TOTAL MAINTENANCE COST = \$ 824.40

TOTAL LIFE-CYCLE BLADE COST PER AIRCRAFT \$46,151.90  
 =====

MAINTENANCE MAN-HOURS/FLIGHT HOUR = 0.0177  
 BLADE-RELATED AIRCRAFT DOWNTIME = 62 HOURS  
 =====

HELICOPTER LIFE-CYCLE BLADE COSTS

FIELD REPAIRABLE/EXPENDABLE BLADE DESIGN 5

NEW BLADE PRICE = \$ 3581  
 MEAN TIME BETWEEN FAILURES = 1275.0 BLADE HOUR  
 FIELD REPAIRABILITY = 49.5 PERCENT

MEAN TIME BETWEEN MAINTENANCE ACTIONS (BLADE HOURS):

REPLACEMENTS = 1673.0  
 REMOVALS FOR REPAIR OR REPLACEMENT = 1645.3  
 REPAIRS = 2620.9  
 DAMAGE REPLACEMENTS = 2557.8  
 UNSCHEDULED MAINTENANCE = 1275.0  
 SCHEDULED MAINTENANCE (RETIREMENT) = 5000.0  
 ALL MAINTENANCE ACTIONS = 1028.6

BLADE EVENTS PER AIRCRAFT LIFE CYCLE:

NUMBER LOST TO ATTRITION = 1.5000  
 NUMBER FATIGUE RETIRED UNMAGED = 2.0000  
 NUMBER REPAIRED ON AIRCRAFT = 3.7484  
 NUMBER REPAIRED OFF AIRCRAFT IN FIELD = 0.0270  
 NUMBER SCRAPPED IN FIELD = 3.3926  
 NUMBER DAMAGED AND RETIRED IN FIELD = 0.0140  
 TOTAL NUMBER DAMAGED AND NOT REPAIRED = 3.7065  
 TOTAL NUMBER ALL REPLACEMENTS = 5.9065

MAIN ROTOR BLADE COSTS PER AIRCRAFT LIFE CYCLE:

COST OF INITIAL PROCUREMENT:

NEW AIRCRAFT OUTFITTING COST = \$ 7162.00  
 SPARE COST, WITH CONTAINERS = \$ 2364.00  
 SPARE REPAIR MATERIALS = \$ 15.70  
 REPAIR SUPPORT EQUIPMENT = \$ 160.00  
 TOTAL INITIAL PROCUREMENT COST = \$ 9702.50

COST OF REPLACEMENT BLADES FOR THOSE LOST AND UNSERVICEABLE (INCLUDING BLADE SHIPPING AND CONTAINER SHIPPING COSTS):

BLADES LOST TO ATTRITION = \$ 5634.00  
 DAMAGED BLADES NOT REPAIRED = \$13910.30  
 TIME-EXPIRED UNMAGED BLADES = \$ 7512.00  
 TOTAL REPLACEMENT COST = \$26956.30

COST OF MAINTENANCE ACTIONS (LABOR AND MATERIAL TO INSPECT, REMOVE, REPAIR, REPLACE, ALIGN, AND FLASK):

FIELD WORK ON AIRCRAFT = \$ 324.10  
 FIELD WORK OFF AIRCRAFT = \$ 1.30  
 FIELD FLASK = \$ 140.10  
 FIELD RETIREMENT = \$ 60.40  
 TOTAL MAINTENANCE COST = \$ 526.00

TOTAL LIFE-CYCLE BLADE COST PER AIRCRAFT \$57,184.30  
 =====

MAINTENANCE MAN-HOURS/FLIGHT HOUR = 0.0125  
 BLADE-RELATED AIRCRAFT DOWNTIME = 43 HOURS  
 =====

HELICOPTER LIFE-CYCLE BLADE COSTS

FIELD REPAIRABLE/EXPENDABLE BLADE DESIGN 6

NEW BLADE PRICE = \$ 3654  
 MEAN TIME BETWEEN FAILURES = 769.2 BLADE HOURS  
 FIELD REPAIRABILITY = 51.5 PERCENT

MEAN TIME BETWEEN MAINTENANCE ACTIONS (BLADE HOURS):

REPLACEMENTS = 1256.8  
 REMOVALS FOR REPAIR OR REPLACEMENT = 1247.6  
 REPAIRS = 1496.1  
 DAMAGE REPLACEMENTS = 1583.1  
 UNSCHEDULED MAINTENANCE = 769.2  
 SCHEDULED MAINTENANCE (RETIREMENT) = 6076.4  
 ALL MAINTENANCE ACTIONS = 683.0

BLADE EVENTS PER AIRCRAFT LIFE CYCLE:

NUMBER LOST TO ATTRITION = 1.5000  
 NUMBER FATIGUE RETIRED UN DAMAGED = 1.6403  
 NUMBER REPAIRED ON AIRCRAFT = 6.6331  
 NUMBER REPAIRED OFF AIRCRAFT IN FIELD = 0.0453  
 NUMBER SCRAPPED IN FIELD = 6.2945  
 NUMBER DAMAGED AND RETIRED IN FIELD = 0.0222  
 TOTAL NUMBER DAMAGED AND NOT REPAIRED = 6.3167  
 TOTAL NUMBER ALL REPLACEMENTS = 7.9570

MAIN ROTOR BLADE COSTS PER AIRCRAFT LIFE CYCLE:

COST OF INITIAL PROCUREMENT:

NEW AIRCRAFT FITTING COST = \$ 7203.00  
 SPARES COST, TIE CONTAINERS = \$ 2403.40  
 SPARE REPAIR MATERIALS = \$ 23.30  
 REPAIR SUPPORT EQUIPMENT = \$ 160.00  
 TOTAL INITIAL PROCUREMENT COST = \$ 9904.70

COST OF REPLACEMENT BLADES FOR THOSE LOST AND UNSERVICEABLE (INCLUDING BLADE SHIPPING AND CONTAINER SHIPPING COSTS):

BLADES LOST TO ATTRITION = \$ 5743.50  
 DAMAGED BLADES NOT REPAIRED = \$23699.70  
 TIME-EXPIRED UN DAMAGED BLADES = \$ 6230.70  
 TOTAL REPLACEMENT COST = \$35723.90

COST OF MAINTENANCE ACTIONS (LABOR AND MATERIAL TO INSPECT, REMOVE, REPAIR, REPLACE, ALIGN, AND TRACK):

FIELD REPAIR ON AIRCRAFT = \$ 576.60  
 FIELD REPAIR OFF AIRCRAFT = \$ 2.20  
 FIELD SCRAP = \$ 226.60  
 FIELD RETIREMENT = \$ 49.90  
 TOTAL MAINTENANCE COST = \$ 855.30

TOTAL LIFE-CYCLE BLADE COST PER AIRCRAFT \$47,433.30  
 =====

MAINTENANCE MAN-HOURS/FLIGHT HOUR = 0.0176  
 BLADE-RELATED AIRCRAFT DOWNTIME = 63 HOURS  
 =====

HELICOPTER LIFE-CYCLE BLADE COSTS

FIELD REPAIRABLE/REPENDABLE BLADE DESIGN 6

NEW BLADE PRICE = \$ 3694  
 MEAN TIME BETWEEN FAILURES = 1232.0 BLADE HOURS  
 FIELD REPAIRABILITY = 51.5 PERCENT

MEAN TIME BETWEEN MAINTENANCE ACTIONS (BLADE HOURS):

REPLACEMENTS = 1727.1  
 REPAIRS FOR DAMAGE OR REPLACEMENT = 1719.0  
 REPAIRS = 2493.6  
 DAMAGE REPLACEMENTS = 2621.5  
 UNSCHEDULED MAINTENANCE = 1232.0  
 SCHEDULED MAINTENANCE (RETIREMENT) = 5000.0  
 ALL MAINTENANCE ACTIONS = 1020.4

BLADE EVENTS PER AIRCRAFT LIFE CYCLE:

NUMBER LOST TO ATTRITION = 1.5000  
 NUMBER FATIGUE RETIRED OR DAMAGED = 2.0000  
 NUMBER REPAIRED ON AIRCRAFT = 3.9825  
 NUMBER REPAIRED OFF AIRCRAFT IN FIELD = 0.0275  
 NUMBER SCRAPED IN FIELD = 3.7767  
 NUMBER DAMAGED AND RETIRED IN FIELD = 0.0133  
 TOTAL NUMBER DAMAGED AND NOT REPAIRED = 3.7900  
 TOTAL NUMBER ALL REPLACEMENTS = 5.7900

MAIN POINT BLADE COSTS PER AIRCRAFT LIFE CYCLE:

COST OF INITIAL PROCUREMENT:

NEW AIRCRAFT EQUIPMENT COST = \$ 7893.00  
 SPARE COST, WITH CONTAINERS = \$ 2403.40  
 SPARE REPAIR MATERIALS = \$ 17.00  
 REPAIR SUPPORT EQUIPMENT = \$ 160.00  
 TOTAL INITIAL PROCUREMENT COST = \$ 9893.40

COST OF REPLACEMENT BLADES FOR THOSE LOST AND UNSERVICEABLE (INCLUDING BLADE SHIPPING AND CONTAINER SHIPPING COSTS):

BLADES LOST TO ATTRITION = \$ 5743.50  
 DAMAGED BLADES NOT REPAIRED = \$13610.20  
 TIME-RETIRED OR DAMAGED BLADES = \$ 7653.00  
 TOTAL REPLACEMENT COST = \$27011.70

COST OF MAINTENANCE ACTIONS (LABOR AND MATERIAL TO INSPECT, REMOVE, REPAIR, REPLACE, ALIGN, AND TRACK):

FIELD REPAIR ON AIRCRAFT = \$ 345.90  
 FIELD REPAIR OFF AIRCRAFT = \$ 1.30  
 FIELD LOGS = \$ 136.00  
 FIELD RETIREMENT = \$ 60.40  
 TOTAL MAINTENANCE COST = \$ 543.60

TOTAL LIFE-CYCLE BLADE COST PER AIRCRAFT \$57,448.70

MAINTENANCE MAN-HOURS/FLIGHT HOUR = 0.0124  
 BLADE-RELATED AIRCRAFT DOWNTIME = 43 HOURS  
 =====

HELICOPTER LIFE-CYCLE BLADE COSTS

FIELD REPAIRABLE/EXPENDABLE BLADE DESIGN 7

NEW BLADE PRICE = \$ 2340  
 MEAN TIME BETWEEN FAILURES = 742.3 BLADE HOURS  
 FIELD REPAIRABILITY = 61.9 PERCENT

MEAN TIME BETWEEN MAINTENANCE ACTIONS (BLADE HOURS):  
 REPLACEMENTS = 1406.3  
 REMOVALS FOR REPAIR OR REPLACEMENT = 1361.6  
 REPAIRS = 1202.1  
 DAMAGE REPLACEMENTS = 1944.1  
 UNSCHEDULED MAINTENANCE = 742.3  
 SCHEDULED MAINTENANCE (RETIREMENT) = 5037.3  
 ALL MAINTENANCE ACTIONS = 648.2

BLADE EVENTS PER AIRCRAFT LIFE CYCLE:  
 NUMBER LOST TO ATTRITION = 1.5000  
 NUMBER FATIGUE RETIRED UNDAAGED = 1.9647  
 NUMBER REPAIRED ON AIRCRAFT = 3.0327  
 NUMBER REPAIRED OFF AIRCRAFT IN FIELD = 0.2353  
 NUMBER SCRAPPED IN FIELD = 5.1203  
 NUMBER DAMAGED AND RETIRED IN FIELD = 0.0236  
 TOTAL NUMBER DAMAGED AND NOT REPAIRED = 5.1433  
 TOTAL NUMBER ALL REPLACEMENTS = 7.1035

MAIN ROTOR BLADE COSTS PER AIRCRAFT LIFE CYCLE:

COST OF INITIAL PROCUREMENT:  
 NEW AIRCRAFT OUTFITTING COST = \$ 5630.00  
 SPARES COST, WITH CONTAINERS = \$ 1920.00  
 SPARE REPAIR MATERIALS = \$ 32.20  
 REPAIR SUPPORT EQUIPMENT = \$ 160.00  
 TOTAL INITIAL PROCUREMENT COST = \$ 7792.20

COST OF REPLACEMENT BLADES FOR THOSE LOST AND UNSERVICEABLE (INCLUDING  
 BLADE SHIPPING AND CONTAINER SHIPPING COSTS):  
 BLADES LOST TO ATTRITION = \$ 4522.50  
 DAMAGED BLADES NOT REPAIRED = \$ 14977.40  
 TIME-EXPIRED UNDAAGED BLADES = \$ 5923.50  
 TOTAL REPLACEMENT COST = \$ 25443.40

COST OF MAINTENANCE ACTIONS (LABOR AND MATERIAL TO INSPECT, REMOVE,  
 REPAIR, REPLACE, FLIGHT, AND TRACK):  
 FIELD REPAIR ON AIRCRAFT = \$ 653.30  
 FIELD REPAIR OFF AIRCRAFT = \$ 11.40  
 FIELD LOGS = \$ 134.30  
 FIELD RETIREMENT = \$ 59.60  
 TOTAL MAINTENANCE COST = \$ 913.70

TOTAL LIFE-CYCLE BLADE COST PER AIRCRAFT \$34,149.30  
 =====

MAINTENANCE MAN-HOURS/FLIGHT HOUR = 0.0170  
 BLADE-RELATED AIRCRAFT DOWNTIME = 64 HOURS  
 =====

HELICOPTER LIFE-CYCLE BLADE COSTS

FIELD REPAIRABLE/EXPENDABLE BLADE DESIGN 7

NEW BLADE PRICE = \$ 2340  
 MEAN TIME BETWEEN FAILURES = 1238.0 BLADE HOURS  
 FIELD REPAIRABILITY = 61.9 PERCENT

MEAN TIME BETWEEN MAINTENANCE ACTIONS (BLADE HOURS):  
 REPLACEMENTS = 1766.1  
 REMOVALS FOR REPAIR OR REPLACEMENT = 1912.2  
 REPAIRS = 2003.5  
 DAMAGE REPLACEMENTS = 3240.1  
 UNSCHEDULED MAINTENANCE = 1238.0  
 SCHEDULED MAINTENANCE (RETIREMENT) = 5000.0  
 ALL MAINTENANCE ACTIONS = 992.3

BLADE EVENTS PER AIRCRAFT LIFE CYCLE:  
 NUMBER LOST TO ATTRITION = 1.5000  
 NUMBER FATIGUE RETIRED UNDAMAGED = 2.0000  
 NUMBER REPAIRED ON AIRCRAFT = 4.8497  
 NUMBER REPAIRED OFF AIRCRAFT IN FIELD = 0.1415  
 NUMBER SCRAPPED IN FIELD = 3.0722  
 NUMBER DAMAGED AND RETIRED IN FIELD = 0.0141  
 TOTAL NUMBER DAMAGED AND NOT REPAIRED = 3.0863  
 TOTAL NUMBER ALL REPLACEMENTS = 5.0363

MAIN ROTOR BLADE COSTS PER AIRCRAFT LIFE CYCLE:

COST OF INITIAL PROCUREMENT:  
 NEW AIRCRAFT OUTFITTING COST = \$ 5630.00  
 SPARES COST, WITH CONTAINERS = \$ 1920.00  
 SPARE REPAIR MATERIALS = \$ 12.30  
 REPAIR SUPPORT EQUIPMENT = \$ 160.00  
 TOTAL INITIAL PROCUREMENT COST = \$ 7772.30

COST OF REPLACEMENT BLADES FOR THOSE LOST AND UNSERVICEABLE (INCLUDING  
 BLADE SHIPPING AND CONTAINER SHIPPING COSTS):  
 BLADES LOST TO ATTRITION = \$ 4522.50  
 DAMAGED BLADES NOT REPAIRED = \$ 5437.10  
 TIME-EXPIRED UNDAMAGED BLADES = \$ 6030.00  
 TOTAL REPLACEMENT COST = \$ 19041.60

COST OF MAINTENANCE ACTIONS (LABOR AND MATERIAL TO INSPECT, REMOVE,  
 REPAIR, REPLACE, ALIGN, AND TRACK):  
 FIELD REPAIR ON AIRCRAFT = \$ 395.00  
 FIELD REPAIR OFF AIRCRAFT = \$ 6.90  
 FIELD SCRAP = \$ 110.60  
 FIELD RETIREMENT = \$ 60.40  
 TOTAL MAINTENANCE COST = \$ 572.90

TOTAL LIFE-CYCLE BLADE COST PER AIRCRAFT 927,303.80  
 =====

MAINTENANCE MAN-HOURS/FLIGHT HOUR = 0.0117  
 BLADE-RELATED AIRCRAFT DOWNTIME = 43 HOURS  
 =====

RETIRED LIFE-CYCLE BLADE COSTS

FIELD REPAIRABLE/DEPENDABLE BLADE DESIGN

NEW BLADE PRICE = \$ 2913  
 MEAN TIME BETWEEN FAILURES = 742.1 FLIGHT HOURS  
 FIELD REPAIRABILITY = 61.9 PERCENT

MEAN TIME BETWEEN MAINTENANCE ACTIONS (BLADE HOURS):  
 REPLACEMENTS = 1406.3  
 REMOVALS FOR REPAIR OR REPLACEMENT = 1361.6  
 REPAIRS = 1202.1  
 DAMAGE REPLACEMENTS = 1944.2  
 UNSCHEDULED MAINTENANCE = 742.1  
 SCHEDULED MAINTENANCE (RETIREMENT) = 5039.6  
 ALL MAINTENANCE ACTIONS = 643.2

BLADE EVENTS PER AIRCRAFT LIFE CYCLE:  
 NUMBER LOST TO ATTRITION = 1.5000  
 NUMBER FATIGUE RETIRED UNDEMANAGED = 1.9643  
 NUMBER REPAIRED ON AIRCRAFT = 3.0519  
 NUMBER REPAIRED OFF AIRCRAFT IN FIELD = 0.2362  
 NUMBER SCRAPPED IN FIELD = 5.1205  
 NUMBER DAMAGED AND RETIRED IN FIELD = 0.0280  
 TOTAL NUMBER DAMAGED AND NOT REPAIRED = 5.1485  
 TOTAL NUMBER ALL REPLACEMENTS = 7.1033

MAIN MOTOR BLADE COSTS PER AIRCRAFT LIFE CYCLE:

COST OF INITIAL PROCUREMENT:  
 NEW AIRCRAFT OUTFITTING COST = \$ 5326.00  
 SPARES COST, WITH CONTAINERS = \$ 1763.30  
 SPARE REPAIR MATERIALS = \$ 32.20  
 REPAIR SUPPORT EQUIPMENT = \$ 160.00  
 TOTAL INITIAL PROCUREMENT COST = \$ 7982.00

COST OF REPLACEMENT BLADES FOR THOSE LOST AND UNSERVICEABLE (INCLUDING  
 BLADE SHIPPING AND CONTAINER SHIPPING COSTS):  
 BLADES LOST TO ATTRITION = \$ 4632.00  
 DAMAGED BLADES NOT REPAIRED = \$15359.30  
 TIME-DEPLETED UNDEMANAGED BLADES = \$ 6057.30  
 TOTAL REPLACEMENT COST = \$26053.60

COST OF MAINTENANCE ACTIONS (LABOR AND MATERIAL TO INSPECT, REMOVE,  
 REPAIR, REPLACE, ALIGN, AND TRACK):  
 FIELD REPAIR ON AIRCRAFT = \$ 653.30  
 FIELD REPAIR OFF AIRCRAFT = \$ 11.40  
 FIELD SCRAP = \$ 184.30  
 FIELD RETIREMENT = \$ 59.60  
 TOTAL MAINTENANCE COST = \$ 913.30

TOTAL LIFE-CYCLE BLADE COST PER AIRCRAFT \$34,954.40  
 =====

MAINTENANCE MAN-HOURS/FLIGHT HOUR = 0.0170  
 BLADE-RELATED AIRCRAFT DOWNTIME = 64 HOURS  
 =====

Reproduced from  
 best available copy. 

HELICOPTER LIFE-CYCLE BLADE COSTS

FIELD REPAIRABLE/EXPENDABLE BLADE DESIGN 8

NEW BLADE PRICE = \$ 2913  
 MEAN TIME BETWEEN FAILURES = 1233.0 BLADE HOURS  
 FIELD REPAIRABILITY = 61.9 PERCENT

MEAN TIME BETWEEN MAINTENANCE ACTIONS (BLADE HOURS):

REPLACEMENTS = 1966.2  
 REMOVALS FOR REPAIR OR REPLACEMENT = 1918.3  
 REPAIRS = 2008.4  
 DAMAGE REPLACEMENTS = 3240.4  
 UNSCHEDULED MAINTENANCE = 1233.0  
 SCHEDULED MAINTENANCE (RETIREMENT) = 5000.0  
 ALL MAINTENANCE ACTIONS = 992.3

BLADE EVENTS PER AIRCRAFT LIFE CYCLE:

NUMBER LOST TO ATTRITION = 1.5000  
 NUMBER FATIGUE RETIRED UN DAMAGED = 2.0000  
 NUMBER REPAIRED ON AIRCRAFT = 4.3497  
 NUMBER REPAIRED OFF AIRCRAFT IN FIELD = 0.1417  
 NUMBER SCRAPPED IN FIELD = 3.0723  
 NUMBER DAMAGED AND RETIRED IN FIELD = 0.0138  
 TOTAL NUMBER DAMAGED AND NOT REPAIRED = 3.0861  
 TOTAL NUMBER ALL REPLACEMENTS = 5.0361

MAIN ROTOR BLADE COSTS PER AIRCRAFT LIFE CYCLE:

COST OF INITIAL PROCUREMENT:

NEW AIRCRAFT EQUIPPING COST = \$ 5326.00  
 SPARES COST, WITH CONTAINERS = \$ 1763.30  
 SPARE REPAIR MATERIALS = \$ 19.30  
 REPAIR SUPPORT EQUIPMENT = \$ 160.00  
 TOTAL INITIAL PROCUREMENT COST = \$ 7269.10

COST OF REPLACEMENT BLADES FOR THOSE LOST AND UNSERVICEABLE (INCLUDING BLADE SHIPPING AND CONTAINER SHIPPING COSTS):

BLADES LOST TO ATTRITION = \$ 4632.00  
 DAMAGED BLADES NOT REPAIRED = \$ 3693.90  
 TIME-EXPIRED UN DAMAGED BLADES = \$ 6176.00  
 TOTAL REPLACEMENT COST = \$19501.90

COST OF MAINTENANCE ACTIONS (LABOR AND MATERIAL TO INSPECT, REMOVE, REPAIR, REPLACE, ALIGN, AND TRACK):

FIELD REPAIR ON AIRCRAFT = \$ 395.00  
 FIELD REPAIR OFF AIRCRAFT = \$ 6.90  
 FIELD SCRAP = \$ 110.60  
 FIELD RETIREMENT = \$ 60.40  
 TOTAL MAINTENANCE COST = \$ 572.90

TOTAL LIFE-CYCLE BLADE COST PER AIRCRAFT \$23,043.90  
 =====

MAINTENANCE MAN-HOURS/FLIGHT HOUR = 0.0117  
 BLADE-RELATED AIRCRAFT DOWNTIME = 43 HOURS  
 =====

HELICOPTER LIFE-CYCLE BLADE COSTS

FIELD REPAIRABLE/EXPENDABLE BLADE DESIGN 9

NEW BLADE PRICE = \$ 2938  
 MEAN TIME BETWEEN FAILURES = 756.6 BLADE HOURS  
 FIELD REPAIRABILITY = 61.2 PERCENT

MEAN TIME BETWEEN MAINTENANCE ACTIONS (BLADE HOURS):

REPLACEMENTS = 1406.9  
 REMOVALS FOR REPAIR OR REPLACEMENT = 1361.8  
 REPAIRS = 1233.5  
 DAMAGE REPLACEMENTS = 1744.5  
 UNSCHEDULED MAINTENANCE = 756.6  
 SCHEDULED MAINTENANCE (RETIREMENT) = 5038.9  
 ALL MAINTENANCE ACTIONS = 658.7

BLADE EVENTS PER AIRCRAFT LIFE CYCLE:

NUMBER LOST TO ATTRITION = 1.5000  
 NUMBER FATIGUE RETIRED UNDamAGED = 1.9650  
 NUMBER REPAIRED ON AIRCRAFT = 7.8390  
 NUMBER REPAIRED OFF AIRCRAFT IN FIELD = 0.2354  
 NUMBER SCRAPPED IN FIELD = 5.1191  
 NUMBER DAMAGED AND RETIRED IN FIELD = 0.0236  
 TOTAL NUMBER DAMAGED AND NOT REPAIRED = 5.1426  
 TOTAL NUMBER ALL REPLACEMENTS = 7.1077

MAIN ROTOR BLADE COSTS PER AIRCRAFT LIFE CYCLE:

COST OF INITIAL PROCUREMENT:

NEW AIRCRAFT EQUIPPING COST = \$ 5676.00  
 SPARES COST, WITH CONTAINERS = \$ 1713.80  
 SPARE REPAIR MATERIALS = \$ 31.70  
 REPAIR SUPPORT EQUIPMENT = \$ 160.00  
 TOTAL INITIAL PROCUREMENT COST = \$ 7786.50

COST OF REPLACEMENT BLADES FOR THOSE LOST AND UNSERVICEABLE (INCLUDING BLADE SHIPPING AND CONTAINER SHIPPING COSTS):

BLADES LOST TO ATTRITION = \$ 4517.50  
 DAMAGED BLADES NOT REPAIRED = \$ 14933.70  
 TIME-EXPIRED UNDamAGED BLADES = \$ 5920.70  
 TOTAL REPLACEMENT COST = \$ 25423.90

COST OF MAINTENANCE ACTIONS (LABOR AND MATERIAL TO INSPECT, REMOVE, REPAIR, REPLACE, ALIGN, AND TRACK):

FIELD REPAIR ON AIRCRAFT = \$ 648.00  
 FIELD REPAIR OFF AIRCRAFT = \$ 11.40  
 FIELD SCRAP = \$ 134.30  
 FIELD RETIREMENT = \$ 59.70  
 TOTAL MAINTENANCE COST = \$ 903.40

TOTAL LIFE-CYCLE BLADE COST PER AIRCRAFT \$34,113.80  
 =====

MAINTENANCE MAN-HOURS/FLIGHT HOUR = 0.0167  
 BLADE-RELATED AIRCRAFT DOWNTIME = 63 HOURS  
 =====

HELICOPTER LIFE-CYCLE BLADE COSTS

FIELD REPAIRABLE/EXPENDABLE DESIGN 9

NEW BLADE PRICE = \$ 2333  
 MEAN TIME BETWEEN FAILURES = 1261.0 BLADE HOURS  
 FIELD REPAIRABILITY = 61.2 PERCENT

MEAN TIME BETWEEN MAINTENANCE ACTIONS (BLADE HOURS):  
 REPLACEMENTS = 1966.3  
 REMOVALS FOR REPAIR OR REPLACEMENT = 1913.2  
 REPAIRS = 2064.1  
 DAMAGE REPLACEMENTS = 3240.9  
 UNSCHEDULED MAINTENANCE = 1261.0  
 SCHEDULED MAINTENANCE (RETIREMENT) = 5000.0  
 ALL MAINTENANCE ACTIONS = 1007.0

BLADE EVENTS PER AIRCRAFT LIFE CYCLE:  
 NUMBER LOST TO ATTRITION = 1.5000  
 NUMBER FATIGUE RETIRED UNDATED = 2.0000  
 NUMBER REPAIRED ON AIRCRAFT = 4.7034  
 NUMBER REPAIRED OFF AIRCRAFT IN FIELD = 0.1412  
 NUMBER SCRAPPED IN FIELD = 3.0714  
 NUMBER DAMAGED AND RETIRED IN FIELD = 0.0141  
 TOTAL NUMBER DAMAGED AND NOT REPAIRED = 3.0856  
 TOTAL NUMBER ALL REPLACEMENTS = 5.0856

MAIN ROTOR BLADE COSTS PER AIRCRAFT LIFE CYCLE:

COST OF INITIAL PROCUREMENT:  
 NEW AIRCRAFT SUITFITTING COST = \$ 5676.00  
 SPARES COST, WITH CONTAINERS = \$ 1913.30  
 SPARE REPAIR MATERIAL = 17.00  
 REPAIR SUPPORT EQUIPMENT = 160.00  
 TOTAL INITIAL PROCUREMENT COST = \$ 7773.30

COST OF REPLACEMENT BLADES FOR THOSE LOST AND UNSERVICEABLE (INCLUDING  
 BLADE SHIPPING AND CONTAINER SHIPPING COSTS):  
 BLADES LOST TO ATTRITION = \$ 4519.50  
 DAMAGED BLADES NOT REPAIRED = \$ 3431.20  
 TIME-EXPIRED UNDATED BLADES = \$ 6026.00  
 TOTAL REPLACEMENT COST = \$19026.70

COST OF MAINTENANCE ACTIONS (LABOR AND MATERIAL TO INSPECT, REMOVE,  
 REPAIR, REPLACE, ALIGN, AND TRACK):  
 FIELD REPAIR ON AIRCRAFT = \$ 333.30  
 FIELD REPAIR OFF AIRCRAFT = \$ 6.30  
 FIELD SCRAP = \$ 110.60  
 FIELD RETIREMENT = \$ 60.40  
 TOTAL MAINTENANCE COST = \$ 566.70

TOTAL LIFE-CYCLE BLADE COST PER AIRCRAFT \$27,357.20  
 =====

MAINTENANCE MAN-HOURS/FLIGHT HOUR = 0.0116  
 BLADE-RELATED AIRCRAFT DOWNTIME = 42 HOURS  
 =====

HELICOPTER LIFE-CYCLE BLADE COSTS

FIELD REPAIRABLE/EXPENDABLE BLADE DESIGN 10

NEW BLADE PRICE = \$ 2911  
 MEAN TIME BETWEEN FAILURES = 756.6 BLADE HOURS  
 FIELD REPAIRABILITY = 61.2 PERCENT

MEAN TIME BETWEEN MAINTENANCE ACTIONS (BLADE HOURS):  
 REPLACEMENTS = 1407.0  
 REMOVALS FOR REPAIR OR REPLACEMENT = 1361.3  
 REPAIRS = 1203.4  
 DAMAGED REPLACEMENTS = 1944.7  
 UNSCHEDULED MAINTENANCE = 756.6  
 SCHEDULED MAINTENANCE (RETIREMENT) = 5033.7  
 ALL MAINTENANCE ACTIONS = 659.7

BLADE EVENTS PER AIRCRAFT LIFE CYCLE:  
 NUMBER LOST TO ATTRITION = 1.5000  
 NUMBER FATIGUE RETIRED UN DAMAGED = 1.7552  
 NUMBER REPAIRED ON AIRCRAFT = 7.8390  
 NUMBER REPAIRED OFF AIRCRAFT IN FIELD = 0.2353  
 NUMBER SCRAPPED IN FIELD = 5.1193  
 NUMBER DAMAGED AND RETIRED IN FIELD = 0.0230  
 TOTAL NUMBER DAMAGED AND NOT REPAIRED = 5.1423  
 TOTAL NUMBER ALL REPLACEMENTS = 7.1074

MAIN ROTOR BLADE COSTS PER AIRCRAFT LIFE CYCLE:

COST OF INITIAL PROCUREMENT:  
 NEW AIRCRAFT EQUIPPING COST = \$ 5322.00  
 SPARES COST, WITH CONTAINERS = \$ 1962.60  
 SPARE REPAIR MATERIALS = \$ 31.70  
 REPAIR SUPPORT EQUIPMENT = \$ 160.00  
 TOTAL INITIAL PROCUREMENT COST = \$ 7976.30

COST OF REPLACEMENT BLADES FOR THOSE LOST AND UNSERVICEABLE (INCLUDING  
 BLADE SHIPPING AND CONTAINER SHIPPING COSTS):  
 BLADES LOST TO ATTRITION = \$ 4629.00  
 DAMAGED BLADES NOT REPAIRED = \$15345.60  
 TIME-EXPIRED UN DAMAGED BLADES = \$ 6064.50  
 TOTAL REPLACEMENT COST = \$26039.10

COST OF MAINTENANCE ACTIONS (LABOR AND MATERIAL TO INSPECT, REMOVE,  
 REPAIR, REPLACE, ALIGN, AND TRACK):  
 FIELD REPAIR ON AIRCRAFT = \$ 803.00  
 FIELD REPAIR OFF AIRCRAFT = \$ 11.40  
 FIELD SCRAP = \$ 134.30  
 FIELD RETIREMENT = \$ 59.60  
 TOTAL MAINTENANCE COST = \$ 908.30

TOTAL LIFE-CYCLE BLADE COST PER AIRCRAFT \$34,915.30  
 =====

MAINTENANCE MAN-HOURS/FLIGHT HOUR = 0.0169  
 BLADE-RELATED AIRCRAFT DOWNTIME = 63 HOURS  
 =====

TABLE 1. LIFE-CYCLE BLADE COSTS

FIELD REPAIRABLE/EXPENDIBLE BLADE DESIGN 10

NEW BLADE PRICE = \$ 2911  
 MEAN TIME BETWEEN FAILURES = 1261.0 BLADE HOURS  
 FIELD REPAIRABILITY = 61.2 PERCENT

MEAN TIME BETWEEN MAINTENANCE ACTIONS (BLADE HOURS):  
 REPLACE/REPAIR = 1966.4  
 REPAIR/REPLACE OR REPLACEMENT = 1213.2  
 REPAIRS = 2064.0  
 DAMAGED REPLACEMENTS = 3241.1  
 SCHEDULED MAINTENANCE = 1261.0  
 SCHEDULED MAINTENANCE (RETIREMENT) = 5006.0  
 ALL MAINTENANCE ACTIONS = 1007.0

BLADE EVENTS PER AIRCRAFT LIFE CYCLE:  
 NUMBER LOST TO ATTRITION = 1.5090  
 NUMBER FATIGUE RETIRED UN-DAMAGED = 2.0030  
 NUMBER REMOVED ON AIRCRAFT = 4.7034  
 NUMBER REMOVED OFF AIRCRAFT IN FIELD = 0.1415  
 NUMBER SCRAPPED IN FIELD = 3.0716  
 NUMBER DAMAGED AND RETIRED IN FIELD = 0.0133  
 TOTAL NUMBER DAMAGED AND NOT REPAIRED = 3.0849  
 TOTAL NUMBER ALL REPLACEMENTS = 5.0354

MAIN ROTOR BLADE COSTS PER AIRCRAFT LIFE CYCLE:

COST OF INITIAL PROCUREMENT:  
 NEW AIRCRAFT OUTFITTING COST = \$ 5822.00  
 SPARES COST, WITH CONTAINERS = \$ 1962.60  
 SPARE REPAIR MATERIALS = \$ 19.00  
 REPAIR SUPPORT EQUIPMENT = \$ 160.00  
 TOTAL INITIAL PROCUREMENT COST = \$ 7963.60

COST OF REPLACEMENT BLADES FOR THOSE LOST AND UNSERVICEABLE (INCLUDING  
 BLADE SHIPPING AND CONTAINER SHIPPING COSTS):  
 BLADES LOST TO ATTRITION = \$ 4629.00  
 DAMAGED BLADES NOT REPAIRED = \$ 8636.00  
 TIME-EXPIRED UN-DAMAGED BLADES = \$ 6172.00  
 TOTAL REPLACEMENT COST = \$19437.00

COST OF MAINTENANCE ACTIONS (LABOR AND MATERIAL TO INSPECT, REMOVE,  
 REPAIR, REPLACE, ALIGN, AND TRACK):  
 FIELD REPAIR ON AIRCRAFT = \$ 389.80  
 FIELD REPAIR OFF AIRCRAFT = \$ 6.90  
 FIELD SCRAP = \$ 110.60  
 FIELD RETIREMENT = \$ 60.40  
 TOTAL MAINTENANCE COST = \$ 566.70

TOTAL LIFE-CYCLE BLADE COST PER AIRCRAFT \$23,017.30  
 =====

MAINTENANCE MAN-HOURS/FLIGHT HOUR = 0.0116  
 BLADE-RELATED AIRCRAFT DOWNTIME = 42 HOURS  
 =====

HELICOPTER LIFE-CYCLE BLADE COSTS

FIELD REPAIRABLE/EXPENDABLE BLADE DESIGN II

NEW BLADE PRICE = \$ 3315  
 MEAN TIME BETWEEN FAILURES = 1053.4 BLADE HOURS  
 FIELD REPAIRABILITY = 45.7 PERCENT

MEAN TIME BETWEEN MAINTENANCE ACTIONS (BLADE HOURS):  
 REPLACEMENTS = 1407.3  
 HOURS FOR REMOVAL OR REPLACEMENT = 1351.1  
 ALIGNING = 2320.7  
 DAMAGE REPLACE COSTS = 1745.7  
 UNSCHEDULED MAINTENANCE = 1053.4  
 SCHEDULED MAINTENANCE (RETIREMENT) = 5036.6  
 ALL MAINTENANCE ACTIONS = 876.1

BLADE EVENTS PER AIRCRAFT LIFE CYCLE:  
 NUMBER LOST TO ATTRITION = 1.5000  
 NUMBER FATIGUE RETIRED UNDATED = 1.2657  
 NUMBER REPAIRED ON AIRCRAFT = 4.0674  
 NUMBER REPAIRED OFF AIRCRAFT IN FIELD = 0.2412  
 NUMBER SCRAPPED IN FIELD = 5.1194  
 NUMBER DAMAGED AND RETIRED IN FIELD = 0.0202  
 TOTAL NUMBER DAMAGED AND NOT REPAIRED = 5.1396  
 TOTAL NUMBER ALL REPLACEMENTS = 7.1056

MAIN MOTOR BLADE COSTS PER AIRCRAFT LIFE CYCLE:

COST OF INITIAL PROCUREMENT:  
 NEW AIRCRAFT EQUIPPING COST = \$ 6630.00  
 SPARES COST, WITH CONTAINERS = \$ 2205.00  
 SPARE REPAIR MATERIALS = \$ 13.30  
 REPAIR SUPPORT EQUIPMENT = \$ 160.00  
 TOTAL INITIAL PROCUREMENT COST = \$ 9008.30

COST OF REPLACEMENT BLADES FOR THOSE LOST AND UNSERVICEABLE (INCLUDING  
 BLADE SHIPPING AND CONTAINER SHIPPING COSTS):  
 BLADES LOST TO ATTRITION = \$ 5235.00  
 DAMAGED BLADES NOT REPAIRED = \$ 17044.20  
 TIME-SCRAPPED UNDATED BLADES = \$ 6361.20  
 TOTAL REPLACEMENT COST = \$ 29441.10

COST OF MAINTENANCE ACTIONS (LABOR AND MATERIAL TO INSPECT, REMOVE,  
 REPAIR, REPLACE, ALIGN, AND TRACK):  
 FIELD REPAIR ON AIRCRAFT = \$ 277.40  
 FIELD REPAIR OFF AIRCRAFT = \$ 11.70  
 FIELD SCRAP = \$ 134.30  
 FIELD RETIREMENT = \$ 59.60  
 TOTAL MAINTENANCE COST = \$ 533.00

TOTAL LIFE-CYCLE BLADE COST PER AIRCRAFT \$38,932.40  
 =====

MAINTENANCE MAN-HOURS/FLIGHT HOUR = 0.0151  
 BLADE-RELATED AIRCRAFT DOWNTIME = 51 HOURS  
 =====

HELICOPTER LIFE-CYCLE BLADE COSTS

FIELD REPAIRABLE/REPENDABLE BLADE DESIGN 11

NEW BLADE PRICE = \$ 3315  
 MEAN TIME BETWEEN FAILURES = 1764.0 BLADE HOURS  
 FIELD REPAIRABILITY = 45.7 PERCENT

MEAN TIME BETWEEN MAINTENANCE ACTIONS (BLADE HOURS):  
 REPLACEMENTS = 1967.0  
 REMOVALS FOR REPAIR OR REPLACEMENT = 1212.6  
 REPAIRS = 3368.2  
 DAMAGE REPLACEMENTS = 3242.8  
 UNSCHEDULED MAINTENANCE = 1764.0  
 SCHEDULED MAINTENANCE (RETIREMENT) = 5000.0  
 ALL MAINTENANCE ACTIONS = 1304.0

BLADE EVENTS PER AIRCRAFT LIFE CYCLE:  
 NUMBER LOST TO ATTRITION = 1.5000  
 NUMBER FATIGUE RETIRED UNDamAGED = 2.0000  
 NUMBER REPAIRED ON AIRCRAFT = 2.4404  
 NUMBER REPAIRED OFF AIRCRAFT IN FIELD = 0.1447  
 NUMBER SCRAPPED IN FIELD = 3.0717  
 NUMBER DAMAGED AND RETIRED IN FIELD = 0.0121  
 TOTAL NUMBER DAMAGED AND NOT REPAIRED = 3.0338  
 TOTAL NUMBER ALL REPLACEMENTS = 5.0338

MAIN ROTOR BLADE COSTS PER AIRCRAFT LIFE CYCLE:

COST OF INITIAL PROCUREMENT:  
 NEW AIRCRAFT OUTFITTING COST = \$ 6630.00  
 SPARES COST, WITH CONTAINERS = \$ 2205.00  
 SPARE REPAIR MATERIALS = \$ 3.00  
 REPAIR SUPPORT EQUIPMENT = \$ 160.00  
 TOTAL INITIAL PROCUREMENT COST = \$ 9003.00

COST OF REPLACEMENT BLADES FOR THOSE LOST AND UNSERVICEABLE (INCLUDING  
 BLADE SHIPPING AND CONTAINER SHIPPING COSTS):  
 BLADES LOST TO ATTRITION = \$ 5235.00  
 DAMAGED BLADES NOT REPAIRED = \$ 9317.20  
 TIME-EXPIRED UNDamAGED BLADES = \$ 6930.00  
 TOTAL REPLACEMENT COST = \$22032.20

COST OF MAINTENANCE ACTIONS (LABOR AND MATERIAL TO INSPECT, REMOVE,  
 REPAIR, REPLACE, ALIGN, AND TRACK):  
 FIELD REPAIR ON AIRCRAFT = \$ 166.40  
 FIELD REPAIR OFF AIRCRAFT = \$ 7.00  
 FIELD SCRAP = \$ 110.60  
 FIELD RETIREMENT = \$ 60.40  
 TOTAL MAINTENANCE COST = \$ 344.40

TOTAL LIFE-CYCLE BLADE COST PER AIRCRAFT \$31,379.60  
 =====

MAINTENANCE MAN-HOURS/FLIGHT HOUR = 0.0106  
 BLADE-RELATED AIRCRAFT DOWNTIME = 35 HOURS  
 =====

HELICOPTER LIFE-CYCLE BLADE COSTS

FIELD REPAIRABLE/EXPENDABLE BLADE DESIGN 12

NEW BLADE PRICE = \$ 3333  
 MEAN TIME BETWEEN FAILURES = 1053.4 BLADE HOURS  
 FIELD REPAIRABILITY = 45.7 PERCENT

MEAN TIME BETWEEN MAINTENANCE ACTIONS (BLADE HOURS):

REPLACEMENTS = 1407.4  
 REMOVALS FOR REPAIR OR REPLACEMENT = 1361.1  
 REPAIRS = 2320.3  
 DAMAGE REPLACEMENTS = 1945.7  
 UNSCHEDULED MAINTENANCE = 1053.4  
 SCHEDULED MAINTENANCE (RETIREMENT) = 5036.5  
 ALL MAINTENANCE ACTIONS = 876.1

BLADE EVENTS PER AIRCRAFT LIFE CYCLE:

NUMBER LOST TO ATTRITION = 1.5000  
 NUMBER FATIGUE DAMAGED UNREPAIRED = 1.7660  
 NUMBER REPAIRED ON AIRCRAFT = 4.0674  
 NUMBER REPAIRED OFF AIRCRAFT IN FIELD = 0.2414  
 NUMBER SCRAPPED IN FIELD = 5.1197  
 NUMBER DAMAGED AND RETIRED IN FIELD = 0.0198  
 TOTAL NUMBER DAMAGED AND NOT REPAIRED = 5.1394  
 TOTAL NUMBER ALL REPLACEMENTS = 7.1054

MAIN ROTOR BLADE COSTS PER AIRCRAFT LIFE CYCLE:

COST OF INITIAL PROCUREMENT:

NEW AIRCRAFT MAIN ROTOR BLADES = \$ 5776.00  
 SPARE COST, WITH CONTAINERS = \$ 2243.30  
 SPARE REPAIR MATERIALS = \$ 13.30  
 REPAIR SUPPORT EQUIPMENT = \$ 160.00  
 TOTAL INITIAL PROCUREMENT COST = \$ 9193.10

COST OF REPLACEMENT BLADES FOR THOSE LOST AND UNSERVICEABLE (INCLUDING BLADE SHIPPING AND CONTAINER SHIPPING COSTS):

BLADES LOST TO ATTRITION = \$ 5344.50  
 DAMAGED BLADES NOT REPAIRED = \$17707.00  
 TIME-EXPIRED UNREPAIRED BLADES = \$ 7004.90  
 TOTAL REPLACEMENT COST = \$30056.40

COST OF MAINTENANCE ACTIONS (LABOR AND MATERIAL TO INSPECT, REMOVE, REPAIR, REPLACE, ALIGN, AND TRACK):

FIELD REPAIR ON AIRCRAFT = \$ 277.40  
 FIELD REPAIR OFF AIRCRAFT = \$ 11.70  
 FIELD SCRAP = \$ 134.30  
 FIELD RETIREMENT = \$ 59.60  
 TOTAL MAINTENANCE COST = \$ 533.00

TOTAL LIFE-CYCLE BLADE COST PER AIRCRAFT \$39,737.50  
 =====

MAINTENANCE MAN-HOURS/FLIGHT HOUR = 0.0151  
 BLADE-RELATED AIRCRAFT DOWNTIME = 51 HOURS  
 =====

HELICOPTER LIFE-CYCLE BLADE COSTS

FIELD REPAIRABLE/EXPENDABLE BLADE DESIGN 12

NEW BLADE PRICE = \$ 3333  
 MEAN TIME BETWEEN FAILURES = 1764.0 BLADE HOURS  
 FIELD REPAIRABILITY = 45.7 PER CENT

MEAN TIME BETWEEN MAINTENANCE ACTIONS (BLADE HOURS):

REPLACEMENTS = 1947.1  
 REPLACEMENT FOR REPAIR OR REPLACEMENT = 1912.6  
 REPAIRS = 3360.0  
 DAMAGE REPLACEMENTS = 3242.9  
 UNSCHEDULED MAINTENANCE = 1764.0  
 SCHEDULED MAINTENANCE (RETIREMENT) = 5000.0  
 ALL MAINTENANCE ACTIONS = 1304.0

BLADE EVENTS PER AIRCRAFT LIFE CYCLE:

NUMBER LOST TO ATTRITION = 1.5000  
 NUMBER FATIGUE RETIRED OR DAMAGED = 2.0000  
 NUMBER REPAIRED ON AIRCRAFT = 2.4404  
 NUMBER REPAIRED OFF AIRCRAFT IN FIELD = 0.1443  
 NUMBER SCRAPPED IN FIELD = 3.0713  
 NUMBER DAMAGED AND RETIRED IN FIELD = 0.0119  
 TOTAL NUMBER DAMAGED AND NOT REPAIRED = 3.0837  
 TOTAL NUMBER ALL REPLACEMENTS = 5.0837

MAIN ROTOR BLADE COSTS PER AIRCRAFT LIFE CYCLE:

COST OF INITIAL PROCUREMENT:

NEW AIRCRAFT EQUIPPING COST = \$ 6776.00  
 SPARES COST, WITH CONTAINERS = \$ 2243.30  
 SPARE REPAIR MATERIALS = \$ 3.00  
 REPAIR SUPPORT EQUIPMENT = \$ 160.00  
 TOTAL INITIAL PROCUREMENT COST = \$ 9192.30

COST OF REPLACEMENT BLADES FOR THOSE LOST AND UNSERVICEABLE (INCLUDING BLADE SHIPPING AND CONTAINER SHIPPING COSTS):

BLADES LOST TO ATTRITION = \$ 5344.50  
 DAMAGED BLADES NOT REPAIRED = 31002.10  
 TIME-REPAIRED UNDAAGED BLADES = \$ 7126.00  
 TOTAL REPLACEMENT COST = \$22472.60

COST OF MAINTENANCE ACTIONS (LABOR AND MATERIAL TO INSPECT, REMOVE, REPAIR, REPLACE, ALIGN, AND TRACK):

FIELD REPAIR ON AIRCRAFT = \$ 166.40  
 FIELD REPAIR OFF AIRCRAFT = \$ 7.00  
 FIELD SCRAP = \$ 110.60  
 FIELD RETIREMENT = \$ 60.40  
 TOTAL MAINTENANCE COST = \$ 344.40

TOTAL LIFE-CYCLE BLADE COST PER AIRCRAFT \$32,029.90  
 =====

MAINTENANCE MAN-HOURS/FLIGHT HOUR = 0.0106  
 BLADE-RELATED AIRCRAFT DOWNTIME = 35 HOURS  
 =====

HELICOPTER LIFE-CYCLE BLADE COSTS

FRES DESIGN 2 - NO COMBAT

NEW BLADE PRICE = \$ 2338  
 MEAN TIME BETWEEN FAILURES = 891.6 BLADE HOURS  
 FIELD REPAIRABILITY = 61.8 PERCENT

MEAN TIME BETWEEN MAINTENANCE ACTIONS (BLADE HOURS):  
 REPLACEMENTS = 1533.2  
 REPAIRS FOR REPAIR OR REPLACEMENT = 1530.4  
 REPAIRS = 1445.2  
 DAMAGE REPLACEMENTS = 2327.5  
 UNSCHEDULED MAINTENANCE = 391.6  
 SCHEDULED MAINTENANCE (RETIREMENT) = 5000.0  
 ALL MAINTENANCE ACTIONS = 756.7

BLADE EVENTS PER AIRCRAFT LIFE CYCLE:  
 NUMBER LOST TO ATTRITION = 1.5000  
 NUMBER FATIGUE RETIRED/DAMAGED = 2.0000  
 NUMBER REPAIRED ON AIRCRAFT = 6.6314  
 NUMBER REPAIRED OFF AIRCRAFT IN FIELD = 0.2379  
 NUMBER SCRAPPED IN FIELD = 4.2770  
 NUMBER DAMAGED AND RETIRED IN FIELD = 0.0195  
 TOTAL NUMBER DAMAGED AND NOT REPAIRED = 4.2965  
 TOTAL NUMBER ALL REPLACEMENTS = 6.2965

MAIN ROTOR BLADE COSTS PER AIRCRAFT LIFE CYCLE:

COST OF INITIAL PROCUREMENT:  
 NEW AIRCRAFT EQUIPMENT COST = \$ 5776.00  
 SPARES COST, WITH CONTAINERS = \$ 1243.10  
 SPARE REPAIR MATERIALS = \$ 25.40  
 REPAIR SUPPORT EQUIPMENT = \$ 160.00  
 TOTAL INITIAL PROCUREMENT COST = \$ 7910.20

COST OF REPLACEMENT BLADES FOR THOSE LOST AND UNSERVICEABLE (INCLUDING  
 BLADE SHIPPING AND CONTAINER SHIPPING COSTS):  
 BLADES LOST TO ATTRITION = \$ 4594.50  
 DAMAGED BLADES NOT REPAIRED = \$12516.40  
 TIME-EXPIRED/DAMAGED BLADES = \$ 5126.00  
 TOTAL REPLACEMENT COST = \$22236.90

COST OF MAINTENANCE ACTIONS (LABOR AND MATERIAL TO INSPECT, REMOVE,  
 REPAIR, REPLACE, ALIGN, AND TRACK):  
 FIELD REPAIR ON AIRCRAFT = \$ 521.00  
 FIELD REPAIR OFF AIRCRAFT = \$ 11.10  
 FIELD SCRAP = \$ 154.00  
 FIELD RETIREMENT = \$ 60.00  
 TOTAL MAINTENANCE COST = \$ 747.10

TOTAL LIFE-CYCLE BLADE COST PER AIRCRAFT \$31,894.20  
 =====

MAINTENANCE MAN-HOURS/FLIGHT HOUR = 0.0143  
 BLADE-RELATED AIRCRAFT DOWNTIME = 55 HOURS  
 =====

## HELICOPTER LIFE-CYCLE BLADE COSTS

### FREM DESIGN 2 - NO COMBAT

NEW BLADE PRICE = \$ 2333  
 MEAN TIME BETWEEN FAILURES = 1436.0 BLADE HOURS  
 FIELD REPAIRABILITY = 61.3 PERCENT

#### MEAN TIME BETWEEN MAINTENANCE ACTIONS (BLADE HOURS):

REPLACEMENT = 2134.4  
 REMOVALS FOR REPAIR OR REPLACEMENT = 2118.4  
 REPAIRS = 2403.7  
 DAMAGED REPLACEMENTS = 3377.1  
 UNRECOVERED MAINTENANCE = 1436.0  
 SCHEDULED MAINTENANCE (RETIREMENT) = 5000.0  
 ALL MAINTENANCE ACTIONS = 1145.5

#### BLADE EVENTS PER AIRCRAFT LIFE CYCLE:

NUMBER LOST TO ATTRITION = 1.5000  
 NUMBER FATIGUE RETIRED UNDAMAGED = 2.0000  
 NUMBER REPAIRED ON AIRCRAFT = 4.0033  
 NUMBER REPAIRED OFF AIRCRAFT IN FIELD = 0.1427  
 NUMBER SCRAPPED IN FIELD = 2.5662  
 NUMBER DAMAGED AND RETIRED IN FIELD = 0.0117  
 TOTAL NUMBER DAMAGED AND NOT REPAIRED = 2.5779  
 TOTAL NUMBER ALL REPLACEMENTS = 4.5779

#### MAIN ROTOR BLADE COSTS PER AIRCRAFT LIFE CYCLE:

##### COST OF INITIAL PROCUREMENT:

NEW AIRCRAFT OUTFITTING COST = \$ 5776.00  
 SPARES COST, WITH CONTAINERS = \$ 1943.30  
 SPARE REPAIR MATERIALS = \$ 15.30  
 REPAIR SUPPORT EQUIPMENT = \$ 160.00  
 TOTAL INITIAL PROCUREMENT COST = \$ 7900.10

##### COST OF REPLACEMENT BLADES FOR THOSE LOST AND UNSERVICEABLE (INCLUDING BLADE SHIPPING AND CONTAINER SHIPPING COSTS):

BLADES LOST TO ATTRITION = \$ 4594.50  
 DAMAGED BLADES NOT REPAIRED = \$ 6259.10  
 TIME-EXPIRED UNDAMAGED BLADES = \$ 6126.00  
 TOTAL REPLACEMENT COST = \$ 17700.60

##### COST OF MAINTENANCE ACTIONS (LABOR AND MATERIAL TO INSPECT, REMOVE, REPAIR, REPLACE, ALIGN, AND TRACK):

FIELD REPAIR ON AIRCRAFT = \$ 312.60  
 FIELD REPAIR OFF AIRCRAFT = \$ 6.90  
 FIELD SCRAP = \$ 92.40  
 FIELD RETIREMENT = \$ 60.40  
 TOTAL MAINTENANCE COST = \$ 472.20

TOTAL LIFE-CYCLE BLADE COST PER AIRCRAFT \$26,032.00

MAINTENANCE MAN-HOURS/FLIGHT HOUR = 0.0103  
 BLADE-RELATED AIRCRAFT DOWNTIME = 37 HOURS

RELIGIOUS LIFE-CYCLE BLADE COSTS

BLADE DESIGN 2

NEW BLADE PRICE = \$ 8333  
 MEAN TIME BETWEEN FAILURES = 756.6 BLADE HOURS  
 FIELD REPAIRABILITY = 61.2 PERCENT

MEAN TIME BETWEEN MAINTENANCE ACTIONS (BLADE HOURS):  
 REPLACEMENTS = 1945.5  
 REMOVALS FOR REPAIR OR REPLACEMENT = 1020.3  
 REPAIRS = 1233.4  
 DAMAGE REPLACEMENTS = 1944.6  
 UNSCHEDULED MAINTENANCE = 756.6  
 SCHEDULED MAINTENANCE (ATTACHMENT) = 2261.0  
 ALL MAINTENANCE ACTIONS = 566.9

BLADE EVENTS PER AIRCRAFT LIFE CYCLE:  
 NUMBER LOST TO ATTRITION = 1.5000  
 NUMBER FATIGUE REPAIRED UNDATED = 4.4222  
 NUMBER REPAIRED ON AIRCRAFT = 7.8320  
 NUMBER REPAIRED OFF AIRCRAFT IN FIELD = 0.2357  
 NUMBER SCRAPPED IN FIELD = 5.1192  
 NUMBER DAMAGED AND REPAIRED IN FIELD = 0.0232  
 TOTAL NUMBER DAMAGED AND NOT REPAIRED = 5.1424  
 TOTAL NUMBER ALL REPLACEMENTS = 9.5652

MAIN ROTOR BLADE COSTS PER AIRCRAFT LIFE CYCLE:

COST OF INITIAL PROCUREMENT:  
 NEW AIRCRAFT OUTFITTING COST = \$ 5776.00  
 SPARES COST, WITH CONTAINERS = \$ 1948.30  
 SPAKE REPAIR MATERIAL = \$ 31.70  
 REPAIR SUPPORT EQUIPMENT = \$ 160.00  
 TOTAL INITIAL PROCUREMENT COST = \$ 7916.50

COST OF REPLACEMENT BLADES FOR THOSE LOST AND UNSERVICEABLE (INCLUDING  
 BLADE SHIPPING AND CONTAINER SHIPPING COSTS):  
 BLADES LOST TO ATTRITION = \$ 4594.50  
 DAMAGED BLADES NOT REPAIRED = \$15600.00  
 TIME-EXPIRED UNDATED BLADES = \$13547.00  
 TOTAL REPLACEMENT COST = \$33749.50

COST OF MAINTENANCE ACTIONS (LABOR AND MATERIAL TO INSPECT, REMOVE,  
 REPAIR, REPLACE, ALIGN, AND TRACK):  
 FIELD REPAIR ON AIRCRAFT = \$ 643.00  
 FIELD REPAIR OFF AIRCRAFT = \$ 11.40  
 FIELD SCRAP = \$ 134.30  
 FIELD RETIREMENT = \$ 133.40  
 TOTAL MAINTENANCE COST = \$ 977.10

TOTAL LIFE-CYCLE BLADE COST PER AIRCRAFT \$42,643.10  
 =====

MAINTENANCE MAN-HOURS/FLIGHT HOUR = 0.0214  
 BLADE-RELATED AIRCRAFT DOWNTIME = 76 HOURS  
 =====

HELICOPTER LIFE-CYCLE BLADE COSTS

FR/E BLADE DESIGN 2

NEW BLADE PRICE = \$ 2338  
 MEAN TIME BETWEEN FAILURES = 756.6 BLADE HOURS  
 FIELD REPAIRABILITY = 61.2 PERCENT

MEAN TIME BETWEEN MAINTENANCE ACTIONS (BLADE HOURS):  
 REPLACEMENTS = 1249.3  
 REMOVALS FOR REPAIR OR REPLACEMENT = 1213.6  
 REPAIRS = 1208.4  
 DAMAGE REPLACEMENTS = 1944.6  
 UNSCHEDULED MAINTENANCE = 756.6  
 SCHEDULED MAINTENANCE (RETIREMENT) = 3494.1  
 ALL MAINTENANCE ACTIONS = 621.9

BLADE EVENTS PER AIRCRAFT LIFE CYCLE:  
 NUMBER LOST TO ATTRITION = 1.5000  
 NUMBER FATIGUE RETIRED UN-DAMAGED = 2.8620  
 NUMBER REPAIRED ON AIRCRAFT = 7.3390  
 NUMBER REPAIRED OFF AIRCRAFT IN FIELD = 0.2357  
 NUMBER SCRAPPED IN FIELD = 5.1192  
 NUMBER DAMAGED AND RETIRED IN FIELD = 0.0232  
 TOTAL NUMBER DAMAGED AND NOT REPAIRED = 5.1424  
 TOTAL NUMBER ALL REPLACEMENTS = 8.0043

MAIN ROTOR BLADE COSTS PER AIRCRAFT LIFE CYCLE:

COST OF INITIAL PROCUREMENT:  
 NEW AIRCRAFT DUFFETING COST = \$ 5776.00  
 SPARES COST, WITH CONTAINERS = \$ 1948.80  
 SPARE REPAIR MATERIALS = \$ 31.70  
 REPAIR SUPPORT EQUIPMENT = \$ 160.00  
 TOTAL INITIAL PROCUREMENT COST = \$ 7916.50

COST OF REPLACEMENT BLADES FOR THOSE LOST AND UNSERVICEABLE (INCLUDING  
 BLADE SHIPPING AND CONTAINER SHIPPING COSTS):  
 BLADES LOST TO ATTRITION = \$ 4594.50  
 DAMAGED BLADES NOT REPAIRED = \$15363.20  
 TIME-EXPIRED UN-DAMAGED BLADES = \$ 3766.20  
 TOTAL REPLACEMENT COST = \$23729.60

COST OF MAINTENANCE ACTIONS (LABOR AND MATERIAL TO INSPECT, REMOVE,  
 REPAIR, REPLACE, ALIGN, AND TRACK):  
 FIELD REPAIR ON AIRCRAFT = \$ 643.00  
 FIELD REPAIR OFF AIRCRAFT = \$ 11.40  
 FIELD SCRAP = \$ 184.30  
 FIELD RETIREMENT = \$ 86.60  
 TOTAL MAINTENANCE COST = \$ 930.30

TOTAL LIFE-CYCLE BLADE COST PER AIRCRAFT \$37,576.40  
 =====

MAINTENANCE MAN-HOURS/FLIGHT HOUR = 0.0186  
 BLADE-RELATED AIRCRAFT DOWNTIME = 63 HOURS  
 =====

HELICOPTER LIFE-CYCLE BLADE COSTS

FR/E BLADE DESIGN 2

NEW BLADE PRICE = \$ 2333  
 MEAN TIME BETWEEN FAILURES = 756.6 BLADE HOURS  
 FIELD REPAIRABILITY = 61.2 PERCENT

MEAN TIME BETWEEN MAINTENANCE ACTIONS (BLADE HOURS):

REPLACEMENTS = 1523.9  
 REMOVALS FOR REPAIR OR REPLACEMENT = 1475.7  
 REPAIRS = 1233.4  
 DAMAGE REPLACEMENTS = 1944.6  
 UNSCHEDULED MAINTENANCE = 756.6  
 SCHEDULED MAINTENANCE (RETIREMENT) = 7150.9  
 ALL MAINTENANCE ACTIONS = 684.2

BLADE EVENTS PER AIRCRAFT LIFE CYCLE:

NUMBER LOST TO ATTRITION = 1.5000  
 NUMBER FATIGUE RETIRED UN-DAMAGED = 1.3284  
 NUMBER REPAIRED ON AIRCRAFT = 7.8390  
 NUMBER REPAIRED OFF AIRCRAFT IN FIELD = 0.2357  
 NUMBER SCRAPPED IN FIELD = 5.1172  
 NUMBER DAMAGED AND RETIRED IN FIELD = 0.0232  
 TOTAL NUMBER DAMAGED AND NOT REPAIRED = 5.1424  
 TOTAL NUMBER ALL REPLACEMENTS = 6.5403

MAIN ROTOR BLADE COSTS PER AIRCRAFT LIFE CYCLE:

COST OF INITIAL PROCUREMENT:

NEW AIRCRAFT OUTFITTING COST = \$ 5776.00  
 SPARES COST, WITH CONTAINERS = \$ 1943.80  
 SPARE REPAIR MATERIALS = \$ 31.70  
 REPAIR SUPPORT EQUIPMENT = \$ 160.00  
 TOTAL INITIAL PROCUREMENT COST = \$ 7916.50

COST OF REPLACEMENT BLADES FOR THOSE LOST AND UNSERVICEABLE (INCLUDING BLADE SHIPPING AND CONTAINER SHIPPING COSTS):

BLADES LOST TO ATTRITION = \$ 4594.50  
 DAMAGED BLADES NOT REPAIRED = \$15144.30  
 TIME-EXPIRED UN-DAMAGED BLADES = \$ 4233.40  
 TOTAL REPLACEMENT COST = \$24022.60

COST OF MAINTENANCE ACTIONS (LABOR AND MATERIAL TO INSPECT, REMOVE, REPAIR, REPLACE, ALIGN, AND TRACK):

FIELD REPAIR ON AIRCRAFT = \$ 643.00  
 FIELD REPAIR OFF AIRCRAFT = \$ 11.40  
 FIELD SCRAP = \$ 184.30  
 FIELD RETIREMENT = \$ 42.60  
 TOTAL MAINTENANCE COST = \$ 836.40

TOTAL LIFE-CYCLE BLADE COST PER AIRCRAFT \$32,825.60  
 =====

MAINTENANCE MAN-HOURS/FLIGHT HOUR = 0.0159  
 BLADE-RELATED AIRCRAFT DOWNTIME = 60 HOURS  
 =====

HELICOPTER LIFE-CYCLE BLADE COSTS

FIVE BLADE DESIGN 2 \*\*\*\*\* NO COMBAT DAMAGE

NEW BLADE PRICE = \$ 2888  
 MEAN TIME BETWEEN FAILURES = 891.6 BLADE HOURS  
 FIELD REPAIRABILITY = 61.3 PERCENT

MEAN TIME BETWEEN MAINTENANCE ACTIONS (BLADE HOURS):

REPLACEMENTS = 1105.7  
 REMOVALS FOR REPAIR OR REPLACEMENT = 1077.4  
 REPAIRS = 1445.2  
 DAMAGE REPLACEMENTS = 2327.5  
 UNSCHEDULED MAINTENANCE = 891.6  
 SCHEDULED MAINTENANCE (RETIREMENT) = 2106.3  
 ALL MAINTENANCE ACTIONS = 626.4

BLADE EVENTS PER AIRCRAFT LIFE CYCLE:

NUMBER LOST TO ATTRITION = 1.5000  
 NUMBER FATIGUE RETIRED UNDATED = 4.7476  
 NUMBER REPAIRED ON AIRCRAFT = 6.6314  
 NUMBER REPAIRED OFF AIRCRAFT IN FIELD = 0.2379  
 NUMBER SCRAPPED IN FIELD = 4.2770  
 NUMBER DAMAGED AND RETIRED IN FIELD = 0.0175  
 TOTAL NUMBER DAMAGED AND NOT REPAIRED = 4.2945  
 TOTAL NUMBER ALL REPLACEMENTS = 9.0441

MAIN ROTOR BLADE COSTS PER AIRCRAFT LIFE CYCLE:

COST OF INITIAL PROCUREMENT:

NEW AIRCRAFT OUTFITTING COST = \$ 5776.00  
 SPARES COST, WITH CONTAINERS = \$ 1943.30  
 SPARE REPAIR MATERIALS = \$ 35.40  
 REPAIR SUPPORT EQUIPMENT = \$ 160.00  
 TOTAL INITIAL PROCUREMENT COST = \$ 7910.20

COST OF REPLACEMENT BLADES FOR THOSE LOST AND UNSERVICEABLE (INCLUDING BLADE SHIPPING AND CONTAINER SHIPPING COSTS):

BLADES LOST TO ATTRITION = \$ 4594.50  
 DAMAGED BLADES NOT REPAIRED = \$ 12937.20  
 TIME-EXPIRED UNREPAIRED BLADES = \$ 14541.30  
 TOTAL REPLACEMENT COST = \$ 32073.60

COST OF MAINTENANCE ACTIONS (LABOR AND MATERIAL TO INSPECT, REMOVE, REPAIR, REPLACE, ALIGN, AND TRACK):

FIELD REPAIR ON AIRCRAFT = \$ 521.00  
 FIELD REPAIR OFF AIRCRAFT = \$ 11.50  
 FIELD SCRAP = \$ 154.00  
 FIELD RETIREMENT = \$ 143.00  
 TOTAL MAINTENANCE COST = \$ 829.50

TOTAL LIFE-CYCLE BLADE COST PER AIRCRAFT \$40,813.30  
 =====

MAINTENANCE MAN-HOURS/FLIGHT HOUR = 0.0193  
 BLADE-RELATED AIRCRAFT DOWNTIME = 69 HOURS  
 =====

HELICOPTER LIFE-CYCLE BLADE COSTS

FR/E BLADE DESIGN 2 \*\*\*\*\* NO COMBAT DAMAGE

NEW BLADE PRICE = \$ 2838  
 MEAN TIME BETWEEN FAILURES = 791.6 BLADE HOURS  
 FIELD REPAIRABILITY = 61.8 PERCENT

MEAN TIME BETWEEN MAINTENANCE ACTIONS (BLADE HOURS):  
 REPLACEMENTS = 1341.9  
 REMOVALS FOR REPAIR OR REPLACEMENT = 1300.4  
 REPAIRS = 1445.2  
 DAMAGE REPLACEMENTS = 2327.5  
 UNSCHEDULED MAINTENANCE = 391.6  
 SCHEDULED MAINTENANCE (RETIREMENT) = 3163.9  
 ALL MAINTENANCE ACTIONS = 695.8

BLADE EVENTS PER AIRCRAFT LIFE CYCLE:  
 NUMBER LOST TO ATTRITION = 1.5000  
 NUMBER FATIGUE RETIRED UN DAMAGED = 3.1557  
 NUMBER REPAIRED ON AIRCRAFT = 6.6314  
 NUMBER REPAIRED OFF AIRCRAFT IN FIELD = 0.2379  
 NUMBER SCRAPPED IN FIELD = 4.2770  
 NUMBER DAMAGED AND RETIRED IN FIELD = 0.0195  
 TOTAL NUMBER DAMAGED AND NOT REPAIRED = 4.2965  
 TOTAL NUMBER ALL REPLACEMENTS = 7.4522

MAIN ROTOR BLADE COSTS PER AIRCRAFT LIFE CYCLE:

COST OF INITIAL PROCUREMENT:  
 NEW AIRCRAFT OUTFITTING COST = \$ 5776.00  
 SPARES COST, WITH CONTAINERS = \$ 1943.30  
 SPARE REPAIR MATERIALS = \$ 25.40  
 REPAIR SUPPORT EQUIPMENT = \$ 160.00  
 TOTAL INITIAL PROCUREMENT COST = \$ 7910.20

COST OF REPLACEMENT BLADES FOR THOSE LOST AND UNSERVICEABLE (INCLUDING  
 BLADE SHIPPING AND CONTAINER SHIPPING COSTS):  
 BLADES LOST TO ATTRITION = \$ 4594.50  
 DAMAGED BLADES NOT REPAIRED = \$12693.40  
 TIME-EXPIRED UN DAMAGED BLADES = \$ 9665.70  
 TOTAL REPLACEMENT COST = \$26953.30

COST OF MAINTENANCE ACTIONS (LABOR AND MATERIAL TO INSPECT, REMOVE,  
 REPAIR, REPLACE, ALIGN, AND TRACK):  
 FIELD REPAIR ON AIRCRAFT = \$ 521.00  
 FIELD REPAIR OFF AIRCRAFT = \$ 11.50  
 FIELD SCRAP = \$ 154.00  
 FIELD RETIREMENT = \$ 95.30  
 TOTAL MAINTENANCE COST = \$ 731.70

TOTAL LIFE-CYCLE BLADE COST PER AIRCRAFT \$35,645.80  
 =====

MAINT'NCE MAN-HOURS/FLIGHT HOUR = 0.0169  
 BLADE-RELATED AIRCRAFT DOWNTIME = 61 HOURS  
 =====

HELICOPTER LIFE-CYCLE BLADE COSTS

FR/E BLADE DESIGN 2 \*\*\*\*\* NO COMBAT DAMAGE

NEW BLADE PRICE = \$ 2388  
 MEAN TIME BETWEEN FAILURES = 891.6 BLADE HOURS  
 FIELD REPAIRABILITY = 61.8 PERCENT

MEAN TIME BETWEEN MAINTENANCE ACTIONS (BLADE HOURS):  
 REPLACEMENTS = 1636.1  
 REMOVALS FOR REPAIR OR REPLACEMENT = 1621.1  
 REPAIRS = 1445.2  
 DAMAGE REPLACEMENTS = 2327.5  
 UNSCHEDULED MAINTENANCE = 891.6  
 SCHEDULED MAINTENANCE (RETIREMENT) = 6113.9  
 ALL MAINTENANCE ACTIONS = 778.2

BLADE EVENTS PER AIRCRAFT LIFE CYCLE:  
 NUMBER LOST TO ATTRITION = 1.5000  
 NUMBER FATIGUE RETIRED UN DAMAGED = 1.6343  
 NUMBER REPAIRED ON AIRCRAFT = 6.6814  
 NUMBER REPAIRED OFF AIRCRAFT IN FIELD = 0.2379  
 NUMBER SCRAPPED IN FIELD = 4.2770  
 NUMBER DAMAGED AND RETIRED IN FIELD = 0.0195  
 TOTAL NUMBER DAMAGED AND NOT REPAIRED = 4.2965  
 TOTAL NUMBER ALL REPLACEMENTS = 5.9303

MAIN ROTOR BLADE COSTS PER AIRCRAFT LIFE CYCLE:

COST OF INITIAL PROCUREMENT:  
 NEW AIRCRAFT OUTFITTING COST = \$ 5776.00  
 SPARES COST, WITH CONTAINERS = \$ 1948.80  
 SPARE REPAIR MATERIALS = \$ 25.40  
 REPAIR SUPPORT EQUIPMENT = \$ 160.00  
 TOTAL INITIAL PROCUREMENT COST = \$ 7910.20

COST OF REPLACEMENT BLADES FOR THOSE LOST AND UNSERVICEABLE (INCLUDING  
 BLADE SHIPPING AND CONTAINER SHIPPING COSTS):  
 BLADES LOST TO ATTRITION = \$ 4594.50  
 DAMAGED BLADES NOT REPAIRED = \$ 12460.40  
 TIME-EXPIRED UN DAMAGED BLADES = \$ 5005.80  
 TOTAL REPLACEMENT COST = \$ 22060.70

COST OF MAINTENANCE ACTIONS (LABOR AND MATERIAL TO INSPECT, REMOVE,  
 REPAIR, REPLACE, ALIGN, AND TRACK):  
 FIELD REPAIR ON AIRCRAFT = \$ 521.00  
 FIELD REPAIR OFF AIRCRAFT = \$ 11.50  
 FIELD SCRAP = \$ 154.00  
 FIELD RETIREMENT = \$ 49.60  
 TOTAL MAINTENANCE COST = \$ 736.10

TOTAL LIFE-CYCLE BLADE COST PER AIRCRAFT \$30,707.10  
 =====

MAINT'NCE MAN-HOURS/FLIGHT HOUR = 0.0142  
 BLADE-RELATED AIRCRAFT DOWNTIME = 53 HOURS  
 =====

### LIST OF SYMBOLS

A/C	aircraft
bl-hr	blade-hour
c.f.	centrifugal force
c.g.	center of gravity
c. rot.	center of rotation
dB	decibel
E	Young's modulus, lb/in. <sup>2</sup>
$f_c$	number of corrective maintenance tasks performed in a given span of flight-hours
$f_p$	number of preventive maintenance tasks performed in a given span of flight-hours
FH	flight-hours
FMEA	failure modes and effects analysis
FREB	field-repairable/ expendable blade
G	torsional modulus, lb/in. <sup>2</sup>
g	standard gravitational acceleration, ft/sec <sup>2</sup>
GW	gross weight, lb
LE	leading edge
$\underline{M}$	maintainability
$\bar{M}$	mean active corrective and preventive action time, hr
$\bar{M}_{ct}$	mean corrective action time, hr
$\bar{M}_{pt}$	mean preventive action time, hr

$M_{max}$	95th percentile maximum repair time, hr
MMH	maintenance man-hours
MTBF	mean time between failures, hr
MTBF <sub>s</sub>	mean time between scraps due to failure, hr
MTBM	mean time between maintenance actions, hr
MTBM <sub>c</sub>	mean time between corrective maintenance, hr
MTBM <sub>p</sub>	mean time between preventive maintenance, hr
MTBR	mean time between removals, hr
MTBR <sub>ep</sub>	mean time between replacements, hr
MTRR	mean time to repair, hr
N	number of elements in sample space
N <sub>p</sub>	number of distinct preventive maintenance actions
N <sub>t</sub>	number of blades remaining at time t
PMMH	productive maintenance man-hours
RCS	radar cross section
RDTE	research, development, test and engineering
rev	revolution
rpm	revolutions per minute
t	repair time, hr
$\bar{t}_q$	median repair time, hr
t <sub>pi</sub>	elapsed time to perform ith preventive maintenance task, hr
TE	trailing edge

$v$	local velocity, ft/sec
$V$	free-stream velocity, ft/sec
$\text{var } x$	variance of $x$
$V_e'$	velocity, ft/sec
$x$	logarithm of blade repair time $t$
$\bar{x}$	mean of $x$
$\omega_r$	bending frequency, rad/sec
$\sigma_x$	standard deviation of $x$
$\sigma_x^2$	variance of $x$