

AD-784 134

**YAW AXIS STABILITY AUGMENTATION SYSTEM
FLIGHT TEST REPORT**

Harvey Ogren, et al

Honeywell, Incorporated

Prepared for:

Army Air Mobility Research and
Development Laboratory

June 1974

DISTRIBUTED BY:

NTIS

**National Technical Information Service
U. S. DEPARTMENT OF COMMERCE
5285 Port Royal Road, Springfield Va. 22151**

Eustis Directorate Position Statement

This report has been reviewed by the Eustis Directorate, U.S. Army Air Mobility Research and Development Laboratory and is considered to be technically sound.

The technical monitor for this contract was Mr. Robert P. Smith, Aero-mechanics, Technology Applications Division.

ACCESSION INFO	
RTIS	White Section <input checked="" type="checkbox"/>
DIC	Diff Section <input type="checkbox"/>
UNCLASSIFIED	<input type="checkbox"/>
JUSTIFICATION	
BY _____	
DISTRIBUTION/AVAILABILITY CODES	
Dist.	Avail. and/or SPECIAL
A	

DISCLAIMERS

The findings in this report are not to be construed as an official Department of the Army position unless so designated by other authorized documents.

When Government drawings, specifications, or other data are used for any purpose other than in connection with a definitely related Government procurement operation, the United States Government thereby incurs no responsibility nor any obligation whatsoever; and the fact that the Government may have formulated, furnished, or in any way supplied the said drawings, specifications, or other data is not to be regarded by implication or otherwise as in any manner licensing the holder or any other person or corporation, or conveying any rights or permission, to manufacture, use, or sell any patented invention that may in any way be related thereto.

Trade names cited in this report do not constitute an official endorsement or approval of the use of such commercial hardware or software.

DISPOSITION INSTRUCTIONS

Destroy this report when no longer needed. Do not return it to the originator.

Unclassified

SECURITY CLASSIFICATION OF THIS PAGE (When Data Entered)

REPORT DOCUMENTATION PAGE		READ INSTRUCTIONS BEFORE COMPLETING FORM
1. REPORT NUMBER USAAMRDL-TR-74-39	2. GOVT ACCESSION NO.	3. RECIPIENT'S CATALOG NUMBER AD-784 134
4. TITLE (and Subtitle) YAW AXIS STABILITY AUGMENTATION SYSTEM FLIGHT TEST REPORT		5. TYPE OF REPORT & PERIOD COVERED
		6. PERFORMING ORG. REPORT NUMBER
7. AUTHOR(s) Harvey Ogren Donald Sotanski LeRoy Genaw		8. CONTRACT OR GRANT NUMBER(s) DAAJ02-72-C-0111
9. PERFORMING ORGANIZATION NAME AND ADDRESS Honeywell Inc. Government and Aeronautical Products Division Minneapolis, Minnesota 55413		10. PROGRAM ELEMENT, PROJECT, TASK AREA & WORK UNIT NUMBERS
11. CONTROLLING OFFICE NAME AND ADDRESS Eustis Directorate, U.S. Army Air Mobility Research and Development Laboratory Fort Eustis, Virginia 23604		12. REPORT DATE June 1974
		13. NUMBER OF PAGES
14. MONITORING AGENCY NAME & ADDRESS (if different from Controlling Office)		15. SECURITY CLASS. (of this report)
		15a. DECLASSIFICATION/DOWNGRADING SCHEDULE
16. DISTRIBUTION STATEMENT (of this Report) Approved for public release; distribution unlimited.		
17. DISTRIBUTION STATEMENT (of the abstract entered in Block 20, if different from Report)		
18. SUPPLEMENTARY NOTES		
19. KEY WORDS (Continue on reverse side if necessary and identify by block number) Flight testing Axes Fluidics Stability Yaw Reproduced by NATIONAL TECHNICAL INFORMATION SERVICE U S Department of Commerce Springfield VA 22151		
20. ABSTRACT (Continue on reverse side if necessary and identify by block number) This report describes the design and flight tests of a hydrofluidic yaw stability augmentation system (SAS) for an OH-58A helicopter. The design objective was to improve stability characteristics in yaw for all flight conditions from hover to 120 kn. The yaw SAS, which initially featured only high-passed yaw rate feedback, was installed in an OH-58A helicopter and flight tested in 1972. Performance at forward flight speeds was satisfactory; but at hover, yaw rates were excessive. The system was then modified to add a straight-through yaw rate feedback term. Flight tests of this configuration were conducted from October-December 1973. Results were satisfactory.		

DD FORM 1 JAN 73 1473 EDITION OF 1 NOV 65 IS OBSOLETE

Unclassified

SECURITY CLASSIFICATION OF THIS PAGE (When Data Entered)

PREFACE

This document is the final report on a flight test program authorized by the Eustis Directorate, U. S. Army Air Mobility Research and Development Laboratory under Contract DAAJ02-72-C-0111. The technical monitor of this program was Mr. R. P. Smith. This program is part of the U. S. Army's continuing effort to develop stability augmentation systems for helicopters. The work presented in this report started June 1, 1972, and was completed November 30, 1973.

TABLE OF CONTENTS

PREFACE	iii
LIST OF ILLUSTRATIONS	vi
LIST OF TABLES	xi
INTRODUCTION	1
ANALYTICAL BACKGROUND	2
High-Passed Yaw Rate Feedback YG1105A01	2
Addition of Straight-Through Yaw Rate YG1116A01	7
SYSTEM INSTALLATION	11
General	11
Mechanical Installation	11
Electrical Installation	21
Hydraulic Installation	21
Instrumentation	26
FLIGHT TEST RESULTS	41
Directional Control Power	41
Angular Velocity Buildup	87
Damping	87
Switching Transients	91
Autorotation	91
Pilot Comments - Summary	92
CONCLUSIONS	98
LIST OF SYMBOLS	99

LIST OF ILLUSTRATIONS

<u>Figure</u>		
1	OH-58A Analog Simulation	4
2	OH-58A Yaw SAS Using Only High-Passed Yaw Rate . .	6
3	Duplication of Flight Test Results, Yaw Step (Hover) $N_r = .35$	8
4	OH-58A Yaw SAS With High-Passed Plus Straight- Through Yaw Rate Loop	9
5	Yaw Steps (Hover) $\delta_{\downarrow m} = .35$ In.	10
6	YG1105A01 HYSAS With Actuators and Mounting Hardware	12
7	YG1116A01 HYSAS With Actuators and Mounting Hardware	13
8	Sketch of SAS Assembly and Linkage Installation	14
9	Looking Into Tail-Boom Connection Point - As-Received OH-58A	15
10	Looking Into Tail-Boom Connection Point - Modified OH-58A	16
11	YG1105A01 HYSAS Installed	18
12	Sketch of Balance Spring Installation.	19
13	Photograph of Balance Spring Installation - Station 23.8	20
14	Electrical Circuit Schematic	22
15	SAS Switch Original Position	23
16	Center Console	24
17	Block Diagram of the Hydraulic System	25
18	Supply and Return Connected Into OH-58A Hydraulic System	27

LIST OF ILLUSTRATIONS (Continued)

Figure

19	Routing Along Left Side of OH-58A	28
20	View Looking Rearward at Approximately Station 125.00	29
21	View Looking Forward at Approximately Station 125.00	30
22	View Looking Below Engine Where Hydraulic Lines Enter Baggage Area	31
23	Pedal Pickoff - Right Side of OH-58A	32
24	Roll and Pitch Cyclic Pickoff Under Pilot Seat	33
25	Collective Pickoff Under Copilot Seat	35
26	Flight Test Fixture as Used for Pedal Inputs	36
27	Flight Test Fixture as Used for Roll Inputs	37
28	Test Instrumentation as Viewed From Right Side of OH-58A	38
29	Test Instrumentation as Viewed From Left Side of OH-58A	39
30	400 Hz Inverter Mounting	40
31	Yaw Step - Left (Hover, 75 Ft) No Straight-Through Yaw Rate Loop	42
32	Yaw Step - Right (Hover, 75 Ft) No Straight-Through Yaw Rate Loop	43
33	Yaw Steps (Hover, 3,000 Ft) No Straight-Through Yaw Rate Loop	44
34	Yaw Pulses (Hover, 3,000 Ft) No Straight-Through Yaw Rate Loop	45
35	Yaw Steps (60 Kn, 3,000 Ft) No Straight-Through Yaw Rate Loop	46

LIST OF ILLUSTRATIONS (Continued)

Figure

36	Yaw Pulses (60 Kn, 3,000 Ft) No Straight-Through Yaw Rate Loop	47
37	Yaw Steps (60 Kn, 6,000 Ft) No Straight-Through Yaw Rate Loop	48
38	Yaw Pulses (60 Kn, 6,000 Ft) No Straight-Through Yaw Rate Loop	49
39	Yaw Steps (90 Kn, 3,000 Ft) No Straight-Through Yaw Rate Loop	50
40	Yaw Pulses (90 Kn, 3,000 Ft) No Straight-Through Yaw Rate Loop	51
41	Yaw Steps (110 Kn, 3,000 Ft) No Straight-Through Yaw Rate Loop	52
42	Yaw Pulses (110 Kn, 3,000 Ft) No Straight-Through Yaw Rate Loop	53
43	Roll Steps (Hover, 3,000 Ft) No Straight-Through Yaw Rate Loop	54
44	Roll Steps (60 Kn, 3,000 Ft) No Straight-Through Yaw Rate Loop	55
45	Roll Steps (60 Kn, 6,000 Ft) No Straight-Through Yaw Rate Loop	56
46	Roll Steps (90 Kn, 3,000 Ft) No Straight-Through Yaw Rate Loop	57
47	Roll Steps (110 Kn, 3,000 Ft) No Straight-Through Yaw Rate Loop	58
48	Yaw Steps (Hover, 5 Ft) With Straight-Through Yaw Rate Loop	59
49	Yaw Pulses (Hover, 5 Ft) With Straight-Through Yaw Rate Loop	60
50	Yaw Steps (Hover, 3,000 Ft) With Straight-Through Yaw Rate Loop	61

LIST OF ILLUSTRATIONS (Continued)

Figure

51	Yaw Pulses (Hover, 3, 000 Ft) With Straight-Through Yaw Rate Loop	62
52	Yaw Steps (60 Kn, 3, 000 Ft) With Straight-Through Yaw Rate Loop	63
53	Yaw Pulses (60 Kn, 3, 000 Ft) With Straight-Through Yaw Rate Loop	64
54	Yaw Steps (60 Kn, 6, 000 Ft) With Straight-Through Yaw Rate Loop	65
55	Yaw Pulses (60 Kn, 6, 000 Ft) With Straight-Through Yaw Rate Loop	66
56	Yaw Steps (90 Kn, 3, 000 Ft) With Straight-Through Yaw Rate Loop	67
57	Yaw Pulses (90 Kn, 3, 000 Ft) With Straight-Through Yaw Rate Loop	68
58	Yaw Steps (90 Kn, 3, 000 Ft) With Straight-Through Yaw Rate Loop - Access Doors Off	69
59	Yaw Pulses (90 Kn, 3, 000 Ft) With Straight-Through Yaw Rate Loop - Access Doors Off	70
60	Yaw Steps (110 Kn, 3, 000 Ft) With Straight-Through Yaw Rate Loop	71
61	Yaw Pulses (110 Kn, 3, 000 Ft) With Straight-Through Yaw Rate Loop	72
62	Roll Steps (Hover, 3, 000 Ft) With Straight-Through Yaw Rate Loop $\delta_{\phi_m} = .6 \text{ In.}$	73
63	Roll Steps (Hover, 3, 000 Ft) With Straight-Through Yaw Rate Loop $\delta_{\phi_m} = .25 \text{ In.}$	74
64	Roll Steps (60 Kn, 3, 000 Ft) With Straight-Through Yaw Rate Loop $\delta_{\phi_m} = .6 \text{ In.}$	75

LIST OF ILLUSTRATIONS (Concluded)

Figure

65	Roll Steps (60 Kn, 3,000 Ft) With Straight-Through Yaw Rate Loop $\delta_{\frac{3}{8}m} = .25$ In.	76
66	Roll Steps (60 Kn, 6,000 Ft) With Straight-Through Yaw Rate Loop $\delta_{\frac{3}{8}m} = .6$ In.	77
67	Roll Steps (60 Kn, 6,000 Ft) With Straight-Through Yaw Rate Loop $\delta_{\frac{3}{8}m} = .25$ In.	78
68	Roll Steps (90 Kn, 3,000 Ft) With Straight-Through Yaw Rate Loop $\delta_{\frac{3}{8}m} = .6$ In.	79
69	Roll Steps (90 Kn, 3,000 Ft) With Straight-Through Yaw Rate Loop $\delta_{\frac{3}{8}m} = .25$ In.	80
70	Roll Steps (110 Kn, 3,000 Ft) With Straight-Through Yaw Rate Loop	81
71	Roll Steps (110 Kn, 6,000 Ft) With Straight-Through Yaw Rate Loop	82
72	Autorotation (60 Kn) With Straight-Through Yaw Rate Loop	83
73	Autorotation (90, 110 Kn) With Straight-Through Yaw Rate Loop	84
74	Engage/Disengage Transients With Straight-Through Yaw Rate Loop	85
75	Maximum Allowable Yaw Rate Response at Hover	91

LIST OF TABLES

<u>Table</u>		<u>Page</u>
I	OH-58A Analog Simulation Potentiometer Settings	5
II	Directional Control Power	86
III	Angular Velocity Buildup Time	88
IV	Yaw Damping in Forward Flight	89

INTRODUCTION

This report represents the results of flight tests of an OH-58A helicopter equipped with a hydrofluidic yaw stability augmentation system (SAS). The objective of the program was to demonstrate an increase in yaw damping, by use of the yaw SAS, for all flight conditions.

The YG1105A01 yaw SAS was developed in September 1969. It featured only high-passed yaw rate feedback. This configuration was mechanized, installed in an OH-58A, and flight tested in October 1972. Flight tests revealed that absence of any straight-through yaw rate feedback resulted in excessive yaw rate buildup in hover.

The contract was then extended to provide for the addition of a straight-through yaw rate feedback term. The resultant YG1116A01 configuration was mechanized, installed in an OH-58A, and flight tested during October and December 1973, with satisfactory results.

Quantitative results are presented in terms of recordings of aircraft responses to step and pulse inputs. These are summarized in tabular form. Qualitative results are presented in the form of comments by the project pilot.

ANALYTICAL BACKGROUND

HIGH-PASSED YAW RATE FEEDBACK YG1105A01

In September 1969 Honeywell conducted an analog study of a yaw stability augmentation system (SAS) for the OH-58A helicopter using data supplied by the Bell Aircraft Co. Figure 1 illustrates the analog simulation and Table I lists the potentiometer settings used. The analog simulation was used to develop and evaluate a yaw SAS of the configuration shown in Figure 2. The yaw SAS was evaluated for the following ranges of parameters:

IAS	0 to 120 kn
τ	.03 to .1 sec
$K_{\downarrow HP}$	1 to 2 $\frac{\text{in.}}{\text{rad/sec}}$
T_1	.5 to 2.5 sec
K_δ	0 to 1.5 in. / in.

As a result of the evaluation, it was recommended that a yaw SAS with the following parameters be built and flight tested:

τ	.06 sec
$K_{\downarrow HP}$	2 $\frac{\text{in.}}{\text{rad/sec}}$
T_1	2 sec
K_δ	1.5 in. / in.

This configuration was built, and flight tests were completed in October 1972. Initial flight test results led to an increase in gain ($K_{\downarrow HP}$) from 2 to 2.5

$\frac{\text{in.}}{\text{rad/sec}}$, and so subsequent flight tests were conducted at the latter gain.

Following the Honeywell flight test program, ASTA pilot evaluation of the OH-58A helicopter equipped with a YG1105A01 yaw SAS was conducted.

Enhanced performance was reported in these areas:

- Improved roll damping
- Improved spiral stability
- Zero delay time to activate the SAS and minimal engage transients

One deficiency, however, was reported. Resonant high frequency directional boost actuator vibration was noticed by the pilots. Boost actuator vibration is not ascribed to the SAS, as it was experienced with both the SAS on and off. The condition apparently developed from modification to the aircraft control linkages, which enabled installation of the SAS. Correction of this problem is considered mandatory.

Correction of these additional shortcomings is considered desirable:

- Lack of a positive directional control force gradient
- Lack of directional control position centering
- Lack of directional rate damping in hover

Neither control force gradient nor control position centering are ascribed directly to the SAS. They also result from modification to the control linkages, which enabled SAS installation, and in particular, from the significant reduction in control pedal forces. Lack of directional rate damping in hover, where aerodynamic damping is small, is due to the fact that the SAS employed only high-passed yaw rate. There was nothing to restrain steady-state yaw rate.

ASTA pilots complained of excessive yaw rate buildup in hover in response to a step input of pedal. Yaw rates of approximately 133 degrees per second per inch of pedal were observed. This problem was not evident during SAS development on the analog computer nor during the Honeywell flight test program. One reason may have been that Honeywell was constrained to flying in ground effect or above 1,000 feet, whereas ASTA pilots obtained a waiver enabling them to fly at 75 feet where the problem was noted. A second reason may have been Honeywell's design philosophy which was to avoid affecting the pilot's control power. A contributing factor may have been the wording of the specification. Paragraph 3.3.7 of MIL-H-8501A, Amendment 1, dated April 3, 1962 states: "the maximum rate of yaw per inch of rudder pedal displacement from trim while hovering shall not be so high as to cause a tendency for the pilot to overcontrol unintentionally." Thus, determination of yaw rate buildup is relative. If a pilot feels he can take timely corrective action, he would not be dissatisfied with the yaw SAS.

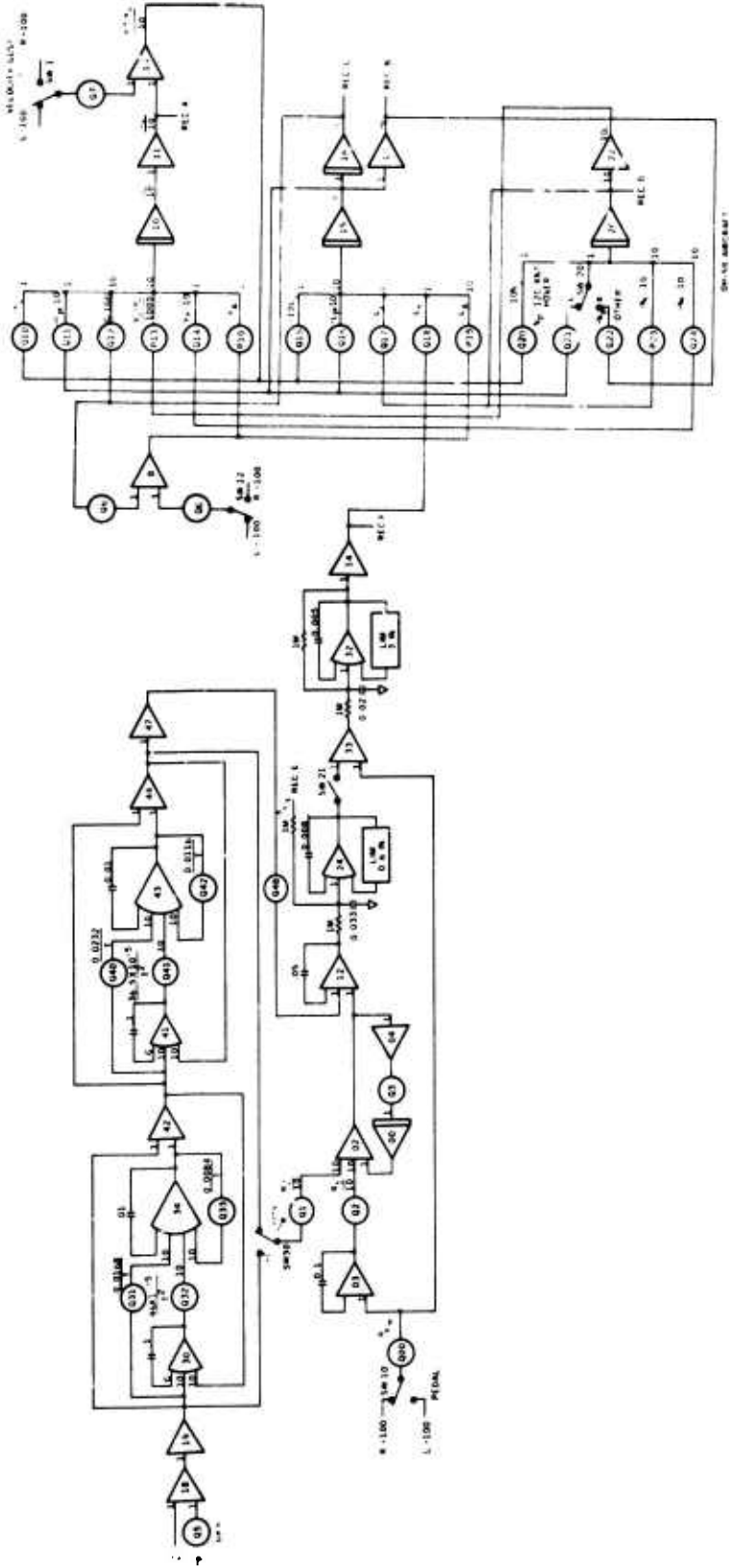

Figure 1. OH-58A Analog Simulation.

TABLE I. OH-58A ANALOG SIMULATION POTENTIOMETER SETTINGS

	Potentiometer	AERO Data						
		Hover	20 kn	40 kn	60 kn	80 kn	100 kn	120 kn
		$-Y_v$	Q10	.038	.058	.096	.135	.170
$-Y_p/10$	Q11	.180	.224	.260	.260	.265	.236	.212
$\frac{g/100}{U} \frac{\sigma Y_r}{1000}$	Q12	.322	→					
$Y_\delta/10$	P13	.0012	.033	.066	.100	.133	.168	.201
$-10 L_v$	Q14	.118	.105	.098	.110	.145	.167	.192
$-L_p/10$	Q15	.250	.280	.360	.500	.610	.720	.860
$+L_r$	Q16	.163	.195	.226	.237	.230	.203	.174
$+L_\delta$	Q17	.220	.320	.470	.640	.670	.900	1.000
$+10 N_v$	Q18	.590	.530	.490	.590	.730	.850	.960
$+N_p$	Q20	.210	.195	.330	.450	.560	.660	.750
$-N_p$	Q21	.035	← SW 20 Left for Hover & 120 kn →					.042
$-N_r/10$	Q22	SW 20 Rt	.320	.390	.310	.170	.035	SW 20 Rt
$-N_\delta/10$	P23	.035	.075	.110	.154	.186	.218	.260
$+Y_A$	Q24	.140	.122	.116	.139	.172	.198	.230
$+L_A$	P10	.800	.800	.800	.800	.810	.850	.910
	P15	.740	.740	.750	.740	.760	.800	.840
		Time Delay (sec)						
	Potentiometer	.050	.030	.075	.100	.060		
$.0168/T$	Q31	.335	.560	.225	.168	.280		
$.00046/T^2$	Q32	.184	.510	.082	.046	.1275		
$.0084/T$	Q33	.168	.280	.112	.084	.140		
$.0232/T$	Q40	.463	.775	.310	.232	.387		
$.000365/T^2$	Q41	.146	.406	.065	.036	.1012		
$.0116/T$	Q42	.232	.387	.155	.116	.1935		

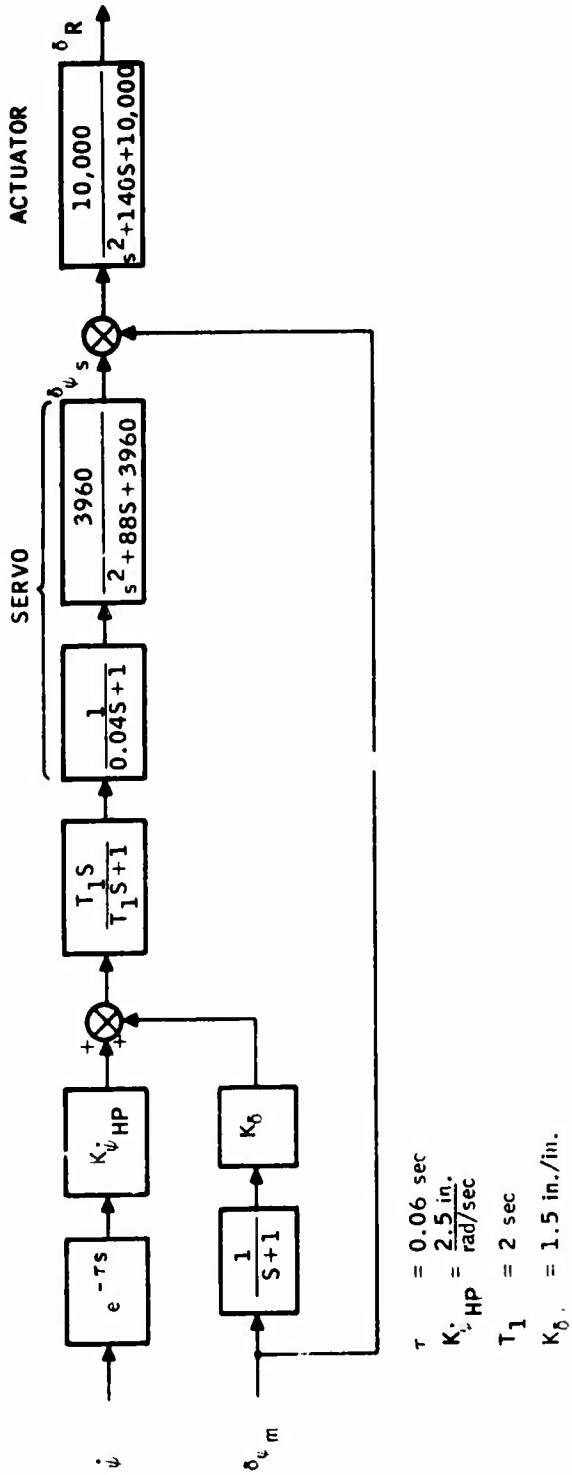

Figure 2. OH-58A Yaw SAS Using Only High-Passed Yaw Rate.

ADDITION OF STRAIGHT-THROUGH YAW RATE YG1116A01

An additional analog study was conducted in December 1972 to develop remedy for the high steady-state yaw rates at hover. Initially, the identical analog simulation was used. After the analog performance obtained in 1969 was duplicated, indicating satisfactory computer operation, the stability derivatives were varied in an attempt to duplicate results obtained during the Government pilot evaluation. Using a free aircraft simulation, it was found that a reduction in the yaw damping derivative (N_r) at hover from .52 to .35 produced almost the same yaw rate response as that obtained in flight test of the free aircraft. This correspondence may be seen by comparing yaw rate responses illustrated in Figure 3 and Figure 31. When the yaw SAS of Figure 2 was added to the simulation, the yaw rate response likewise corresponded to that obtained in flight tests of the aircraft with the yaw SAS engaged. This may also be seen by comparing Figure 3 and Figure 31. These results lend credibility to the analog model in which N_r was reduced to .35.

The analog simulation of Figure 1, with N_r set at .35, was then used to develop and evaluate a modification of the yaw SAS to reduce steady-state yaw rates at hover. The modification consists of adding a straight-through yaw rate term as shown in Figure 4.

Figure 5 shows the simulated yaw rate response to a .35-inch step of pedal for the free aircraft with both the yaw SAS using only high-passed yaw rate feedback, and with the yaw SAS using both high-passed and straight-through yaw rate feedback. Reduction in maximum yaw rates from over 1.25 rad/sec to .65 rad/sec is readily evident. Based on these results, it was recommended that a yaw SAS with a $K_{\downarrow ST} = .25$ be built for flight

test. This configuration, YG1116A01, was built and flight tests were completed on November 30, 1973.

Initial flight test results led to an increase in gain ($K_{\downarrow ST}$) from .25 to .475 $\frac{\text{in.}}{\text{rad/sec}}$. Subsequent flight tests of this configuration were then conducted at the latter gain.

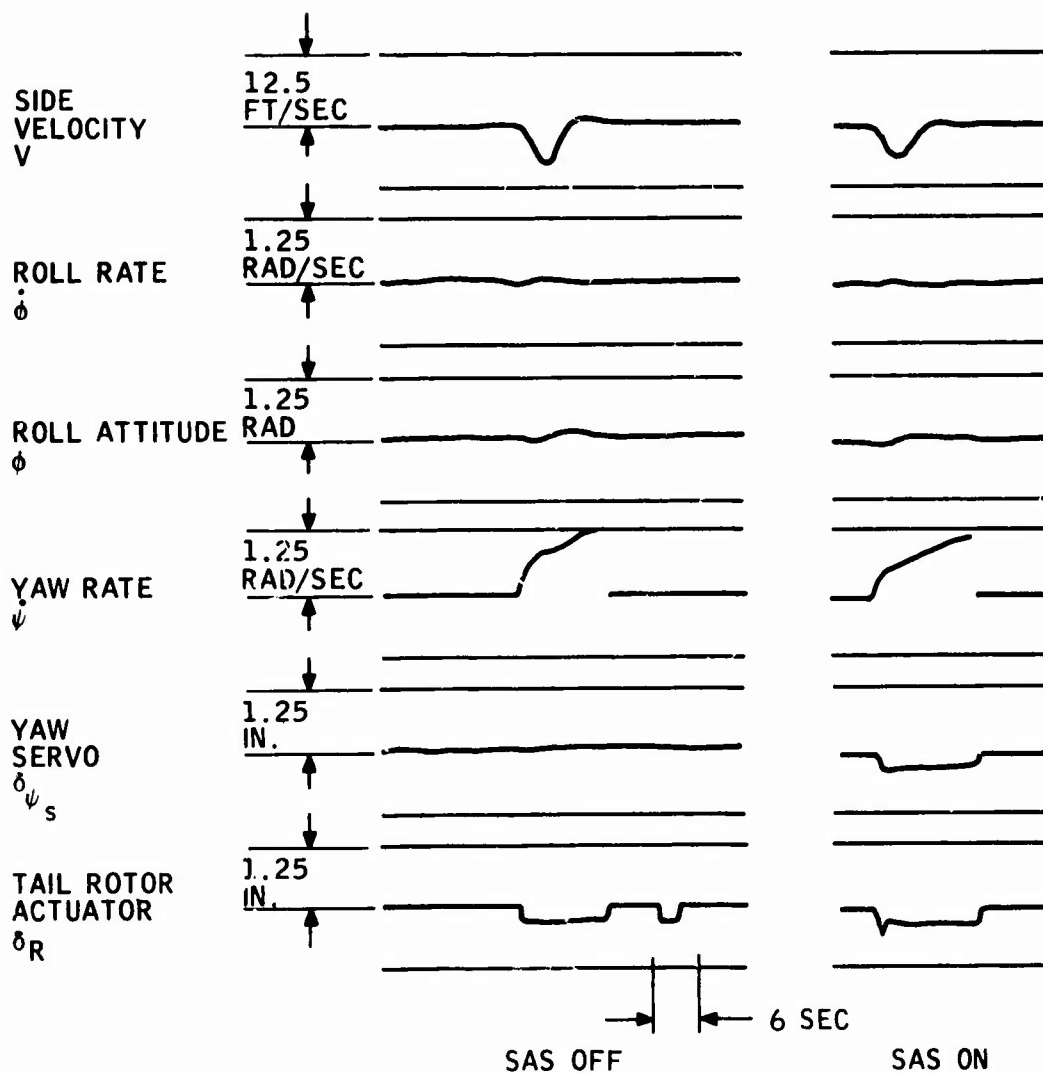
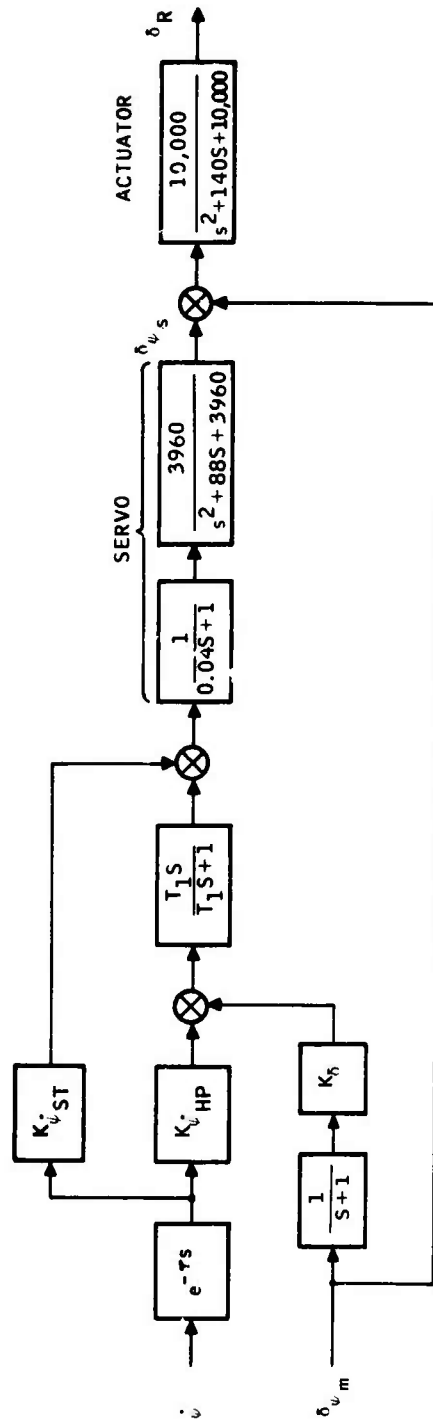

Figure 3. Duplication of Flight Test Results, Yaw Step (Hover) $N_r = .35$.



- $\tau = 0.06 \text{ sec}$
- $K_{\psi HP} = 2.5 \frac{\text{in.}}{\text{rad/sec}}$
- $T_1 = 2 \text{ sec}$
- $K_{\delta} = 1.5 \text{ in./in.}$
- $K_{\psi ST} = 0.475 \text{ rad/sec}$

Figure 4. OH-58A Yaw SAS With High-Passed Plus Straight-Through Yaw Rate Loop.

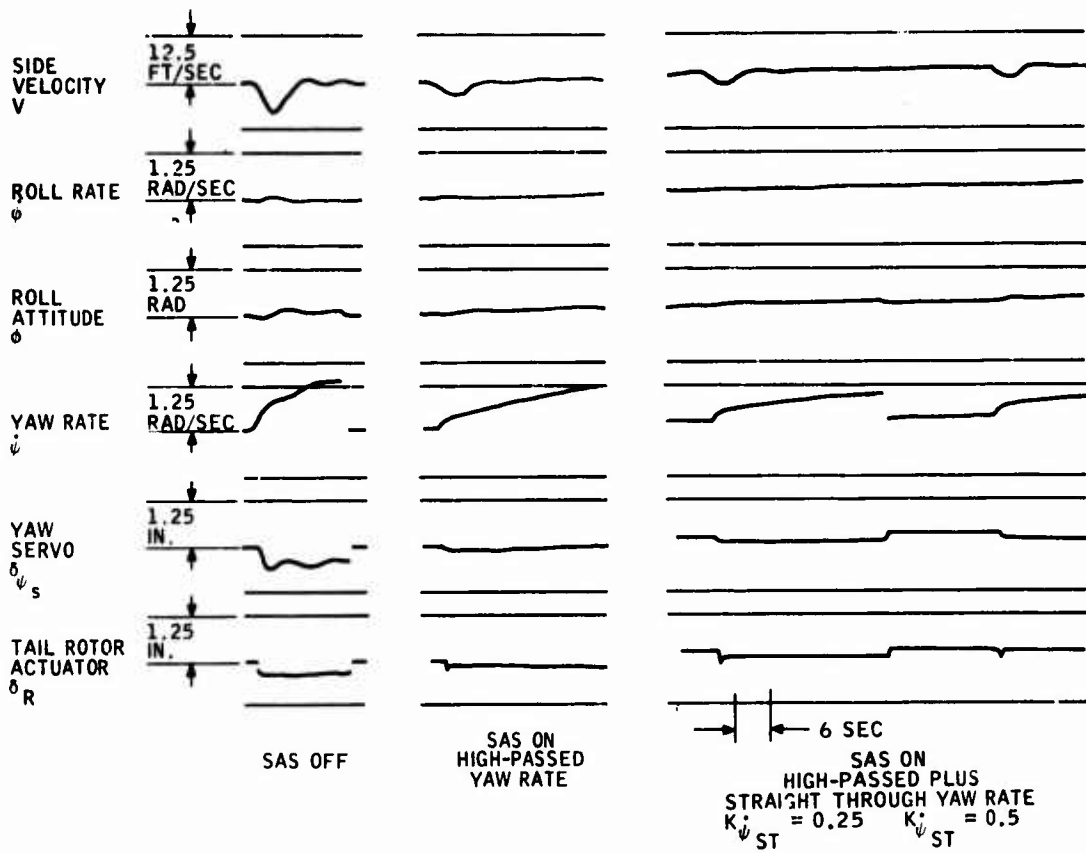

Figure 5. Yaw Steps (Hover) $\delta_{\psi_m} = .35$ In.

SYSTEM INSTALLATION

GENERAL

The installation details and the hydraulic lines were obtained from contract DAAJ02-71-C-0068. Modifications were made, however, to improve system installation.

The electrical installation was modified by changing the switch on the cyclic stick from a normally open to a normally closed type. This allowed the circuit to be of a fail-safe design. If a wire broke, the SAS would center and lock. In the original design a broken wire would go undetected until the system was to be disengaged by the emergency disengage button and then the SAS would not disengage. The pilot could only disengage the SAS by means of the engage switch.

The hydraulic return line was rerouted and connected at the filter rather than in the solenoid valve area. It was cleaner to connect it at the filter because of many hydraulic lines in the solenoid area.

The stop assembly bracket and the balance spring bracket were attached with screws and nuts because a rivet gun would not clear some of the other parts.

Shown in Figure 6 is the YG1105A01 HYSAS mounted on the Jet Ranger servoactuator/boost actuator. This was the first system flown, and from evaluations of this system the modifications to the YG1116A01 HYSAS were made. Figure 7 shows this system mounted on the servoactuator developed to mate with it.

MECHANICAL INSTALLATION

SAS Assembly and Linkages

Figure 8 shows an overall sketch of the SAS assembly installed in the vehicle. This location is just aft and above the baggage compartment. Figure 9, at approximately station 160, is a view looking forward into the body of the vehicle with the tail boom removed. The standard walking beam has been removed prior to installing a new part with flats for the stops. The webs marked A and B were removed.

Figure 10 is the same view with the new walking beam and the stop assembly installed. The stops were installed because the servoactuator

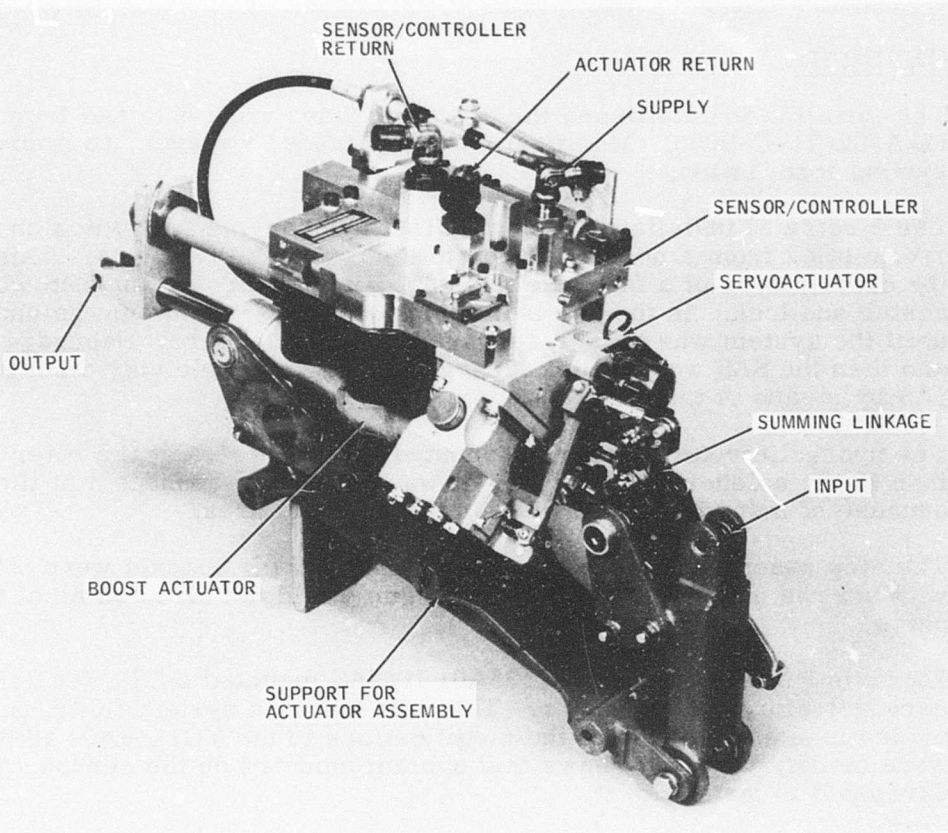

Figure 6. YG1105A01 HYSAS With Actuators and Mounting Hardware.

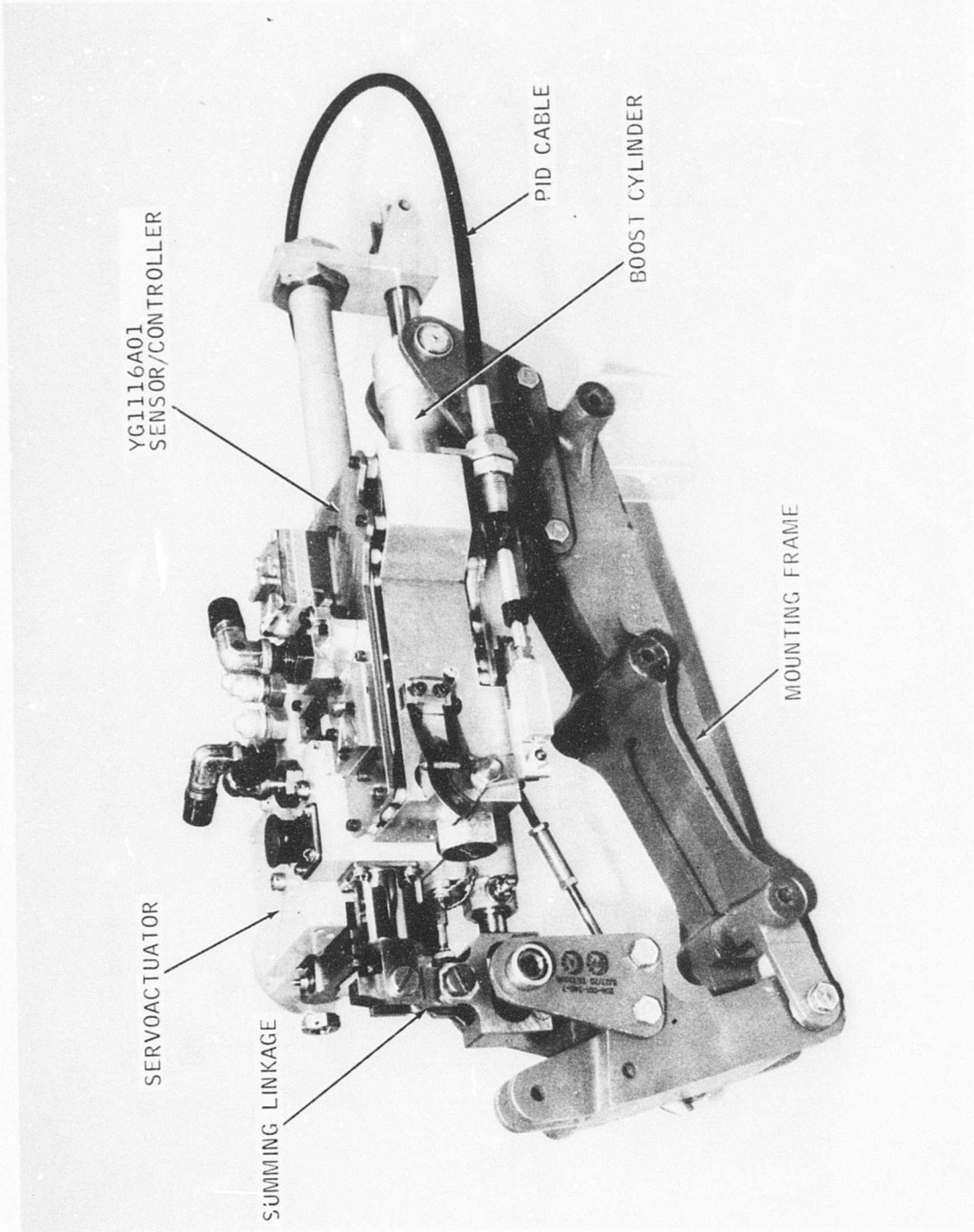

Figure 7. YG1116A01 HYSAS With Actuators and Mounting Hardware.

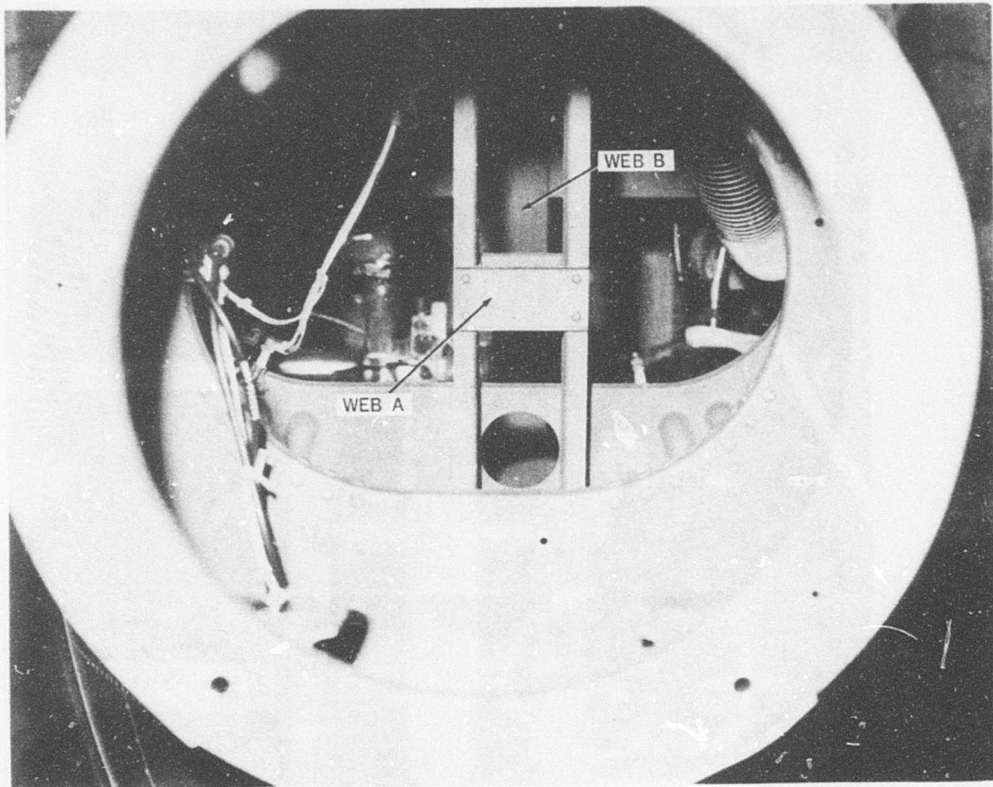

Figure 9. Looking Into Tail-Boom Connection Point - As-Received OH-58A.

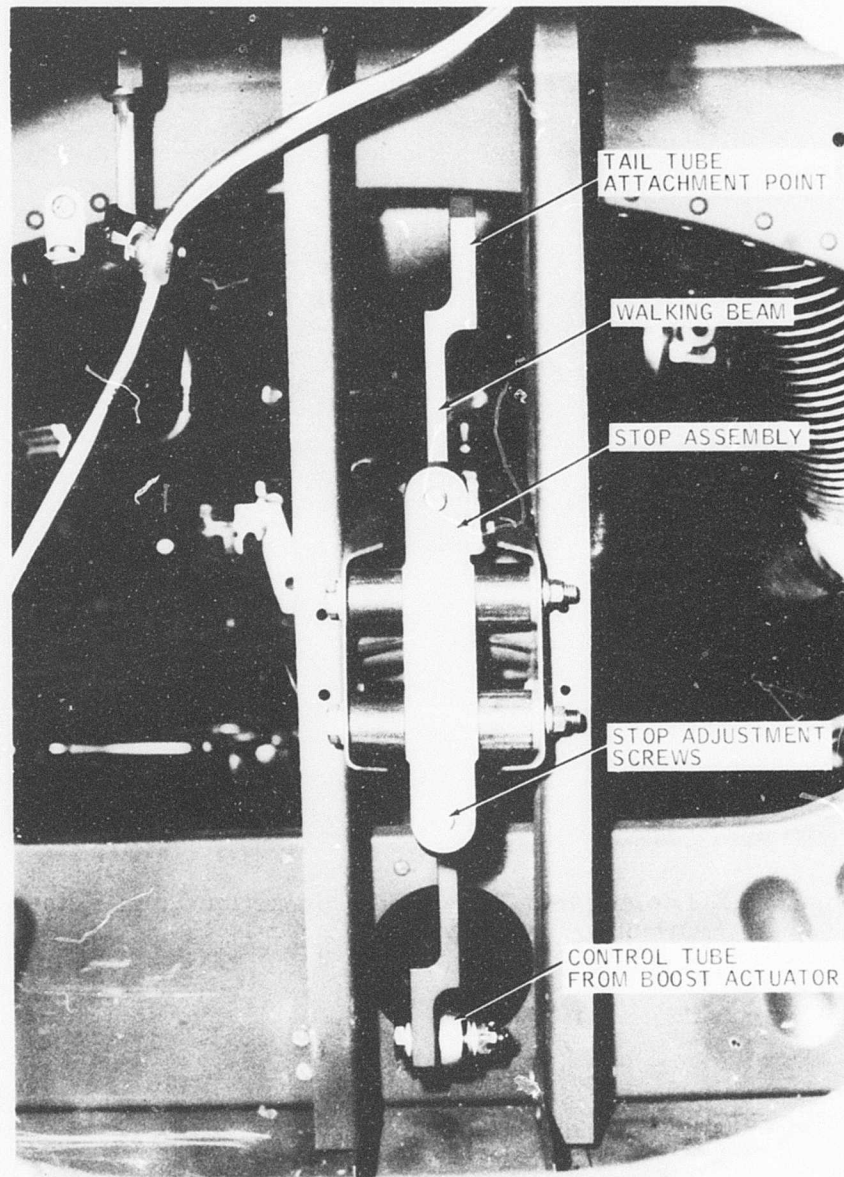

Figure 10. Looking Into Tail-Boom Connection Point - Modified OH-58A.

increases the boost actuator's travel beyond the travel capability of the tail rotor, preventing damage to the tail rotor.

The YG1105A01 HYSAS installation is illustrated in Figure 11. The system is mounted between two sheet metal supports that are riveted in place and stiffened with gussets and clips. These can also be seen in Figure 8.

The normal control tube used in the area of SAS installation was removed and replaced with two shorter tubes that connect the SAS to the directional control system of the vehicle.

Balance Spring

Figure 12 is a sketch of the balance spring installation. Figure 13 shows an actual view. The installation is located under the front of the vehicle at station 23.80. The angle bracket that anchored the spring to the vehicle was attached with screws and nuts because of a stiffener that interfered with use of a rivet gun.

Directional Axis Force Trim

After the aircraft had been flown by a number of pilots, the Government decided that a force trim system should be installed. This had been recommended by various pilots. The OH-58A does not have a boost actuator in the directional axis, so did not have a force trim system in the directional axis. A force trim system is installed on the cyclic controls of the production OH-58A helicopter.

A directional force trim system had been designed and installed by Bell Helicopter Co. on an OH-58A helicopter at the ASTA facility, Edwards, California. This same type of system was purchased from BHC and installed in the OH-58A.

SAS Centering Springs

During the flight test of the YG1105A01 sensor/controller, it was noted that the system output noise level increased when the helicopter main rotor was running. When run with the hydraulic ground cart, the system was quiet.

This lateral motion was caused by the inertial loads of the vibrating vehicle, and the fore and aft motion was caused by the output of the boost actuator. These two motions cause the SAS assembly to move

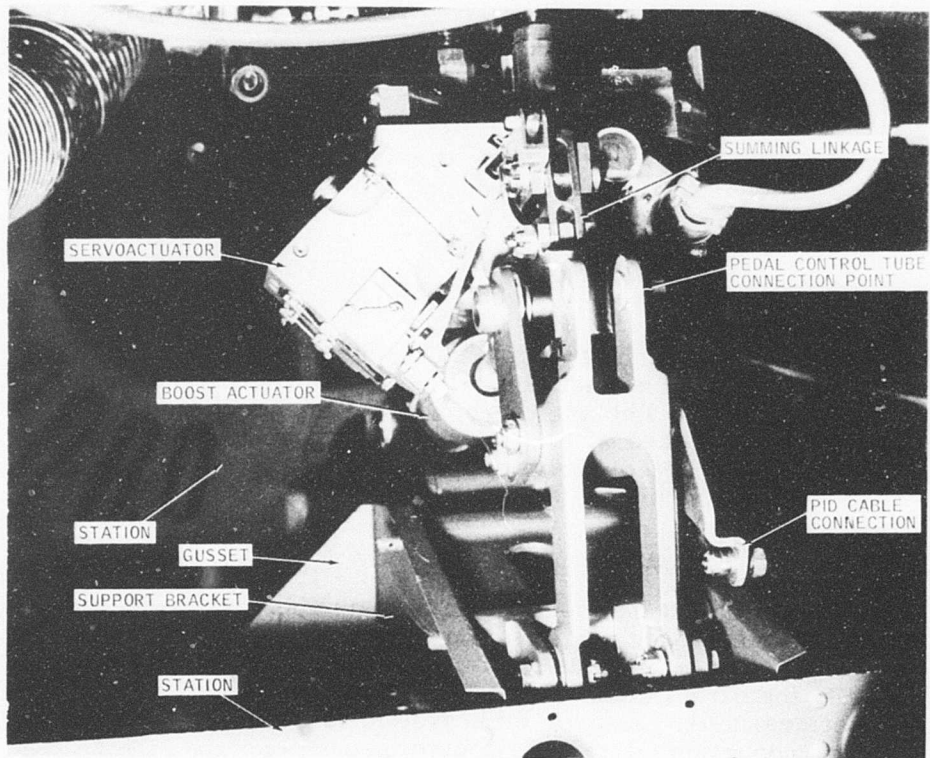

Figure 11. YG1105A01 HYSAS Installed.

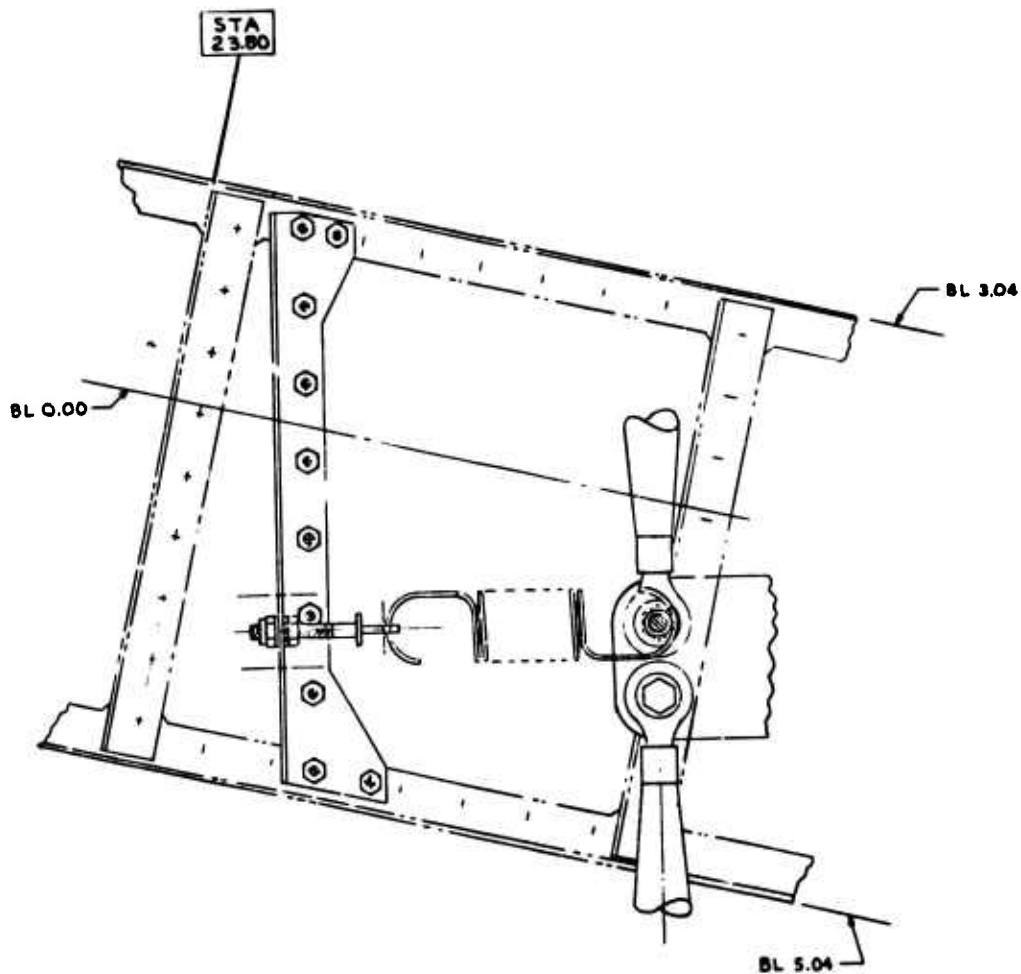

Figure 12. Sketch of Balance Spring Installation.

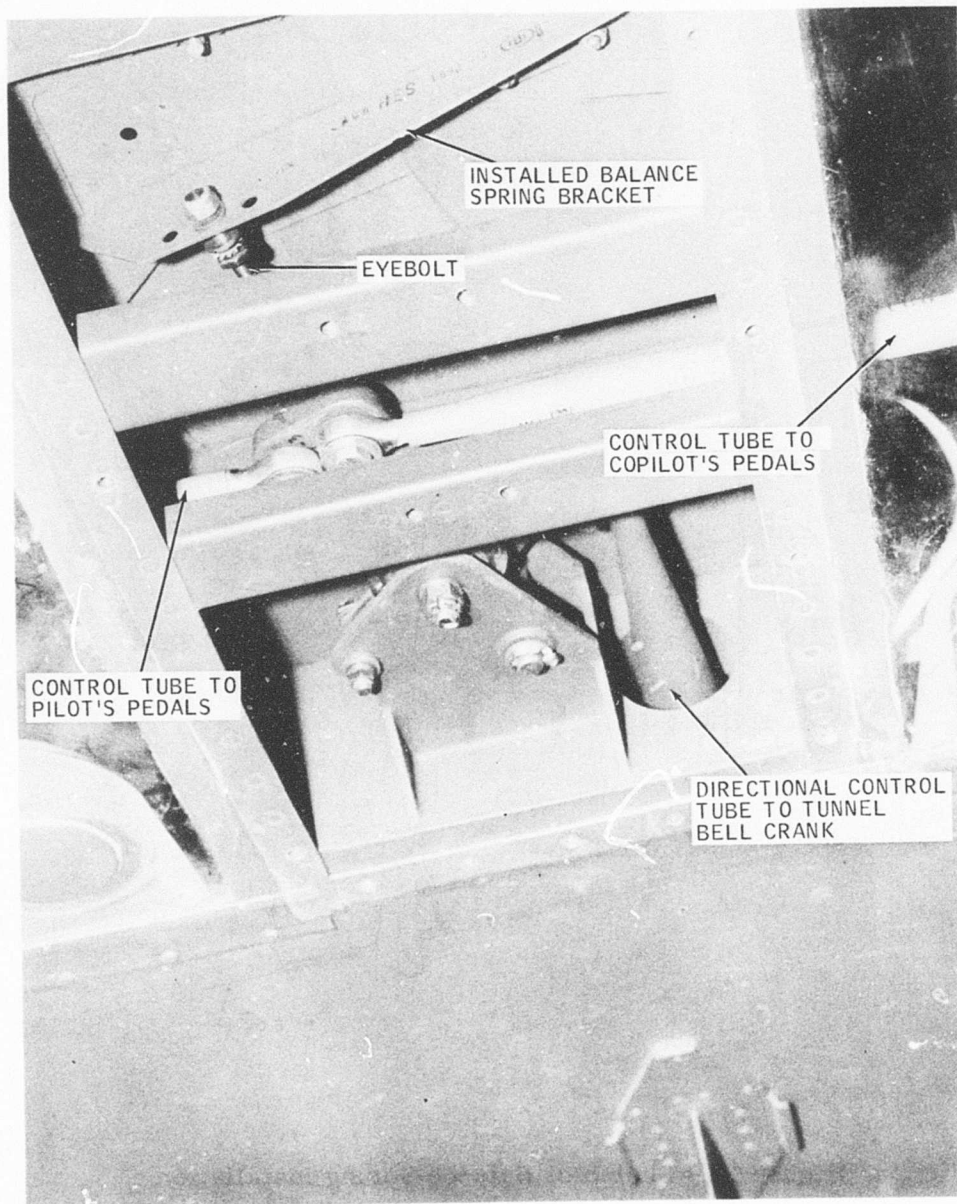

Figure 13. Photograph of Balance Spring Installation - Station 23. 8.

in an elliptical motion as viewed from above. Since the rate sensor is mounted on the actuator, this motion will apply a rate of turn to the sensor that causes the boost actuator to move. This continues as long as the lateral motion of the SAS assembly persists.

To reduce the lateral motion, a pair of heavy springs was attached between the airframe and the top of the SAS assembly. This reduced the motion in the lateral direction and probably detuned the SAS assembly to excitation at the rotor frequency.

The addition of the springs did reduce the noise. They were not considered a production-type fix, so a scissor link was designed to replace the springs. This was installed between the airframe and the top of the SAS assembly. This also reduced the noise.

When the YG1116A01 system was installed, the scissor link was removed. During this flight testing the noise generated by the lateral motion was very small. It is believed to have been small because the mass of the SAS assembly was less than the YG1105A01 assembly and the center of gravity was lowered considerably. It is believed that with a lightweight system it is not necessary to install hardware to control the system's lateral motion.

ELECTRICAL INSTALLATION

The SAS electrical circuit schematic is shown in Figure 14. The SAS was wired such that if any wire breaks, the servoactuator solenoid would be deenergized. This causes the servoactuator to center and lock, making the fail-safe system. Shown in Figure 15 is the emergency disengage button and the original mounting of the SAS engage switch. During flight testing, however, the pilot found it difficult to reach the SAS engage switch with his left hand. It was subsequently moved to the center console location shown in Figure 16. The SAS circuit breaker was mounted in the overhead panel with the other vehicle circuit breakers.

HYDRAULIC INSTALLATION

The hydraulic system is shown in Figure 17. The items inside the dashed lines were added during this program. The directional boost actuator, servoactuator, and sensor/controller were mounted together so that only one supply line was required to supply oil to the three components. Two return lines were necessary, however, since the sensor/controller is isolated from the actuators by a back pressure regulator.

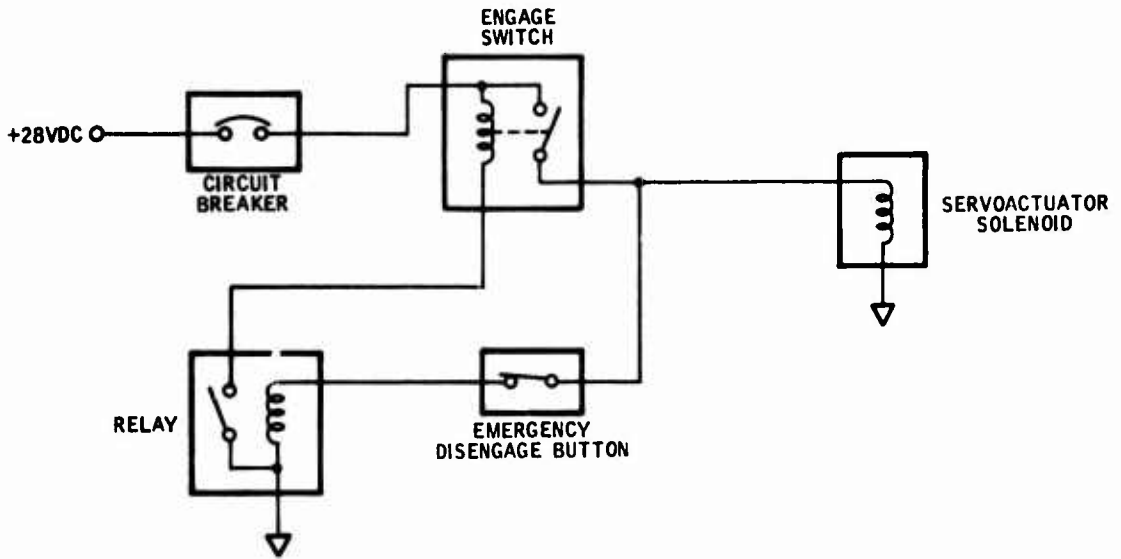

Figure 14. Electrical Circuit Schematic.

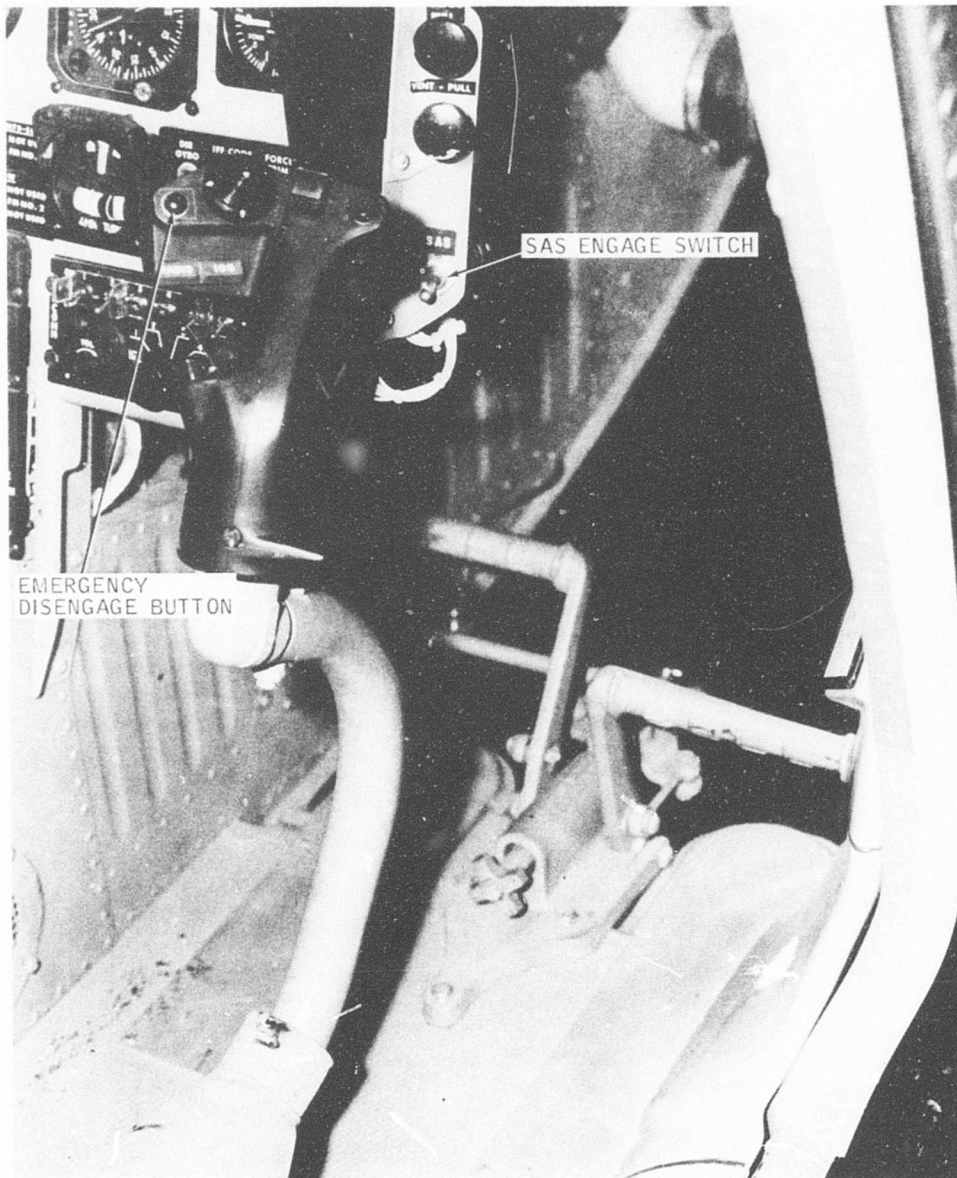

Figure 15. SAS Switch Original Position.

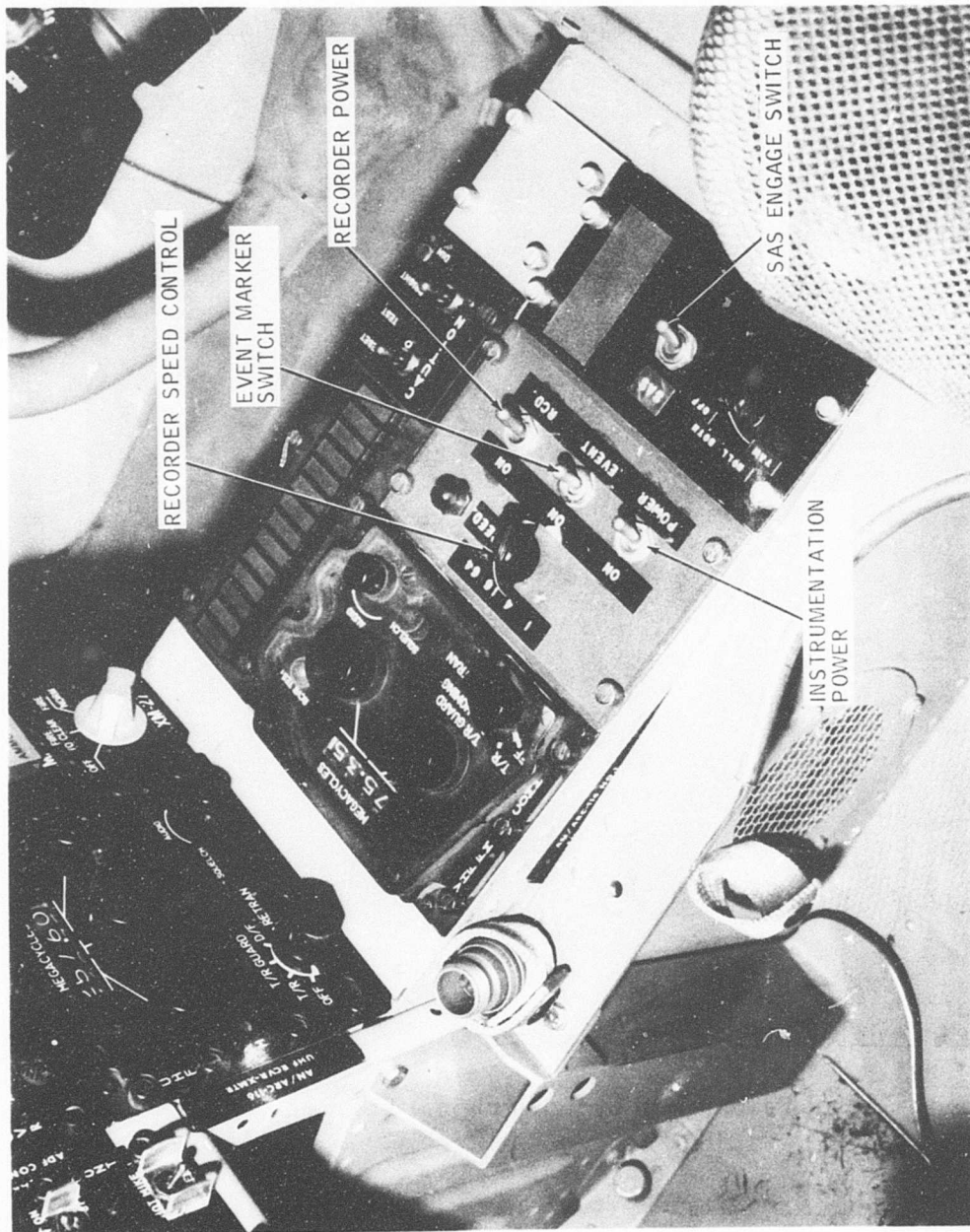

Figure 16. Center Console.

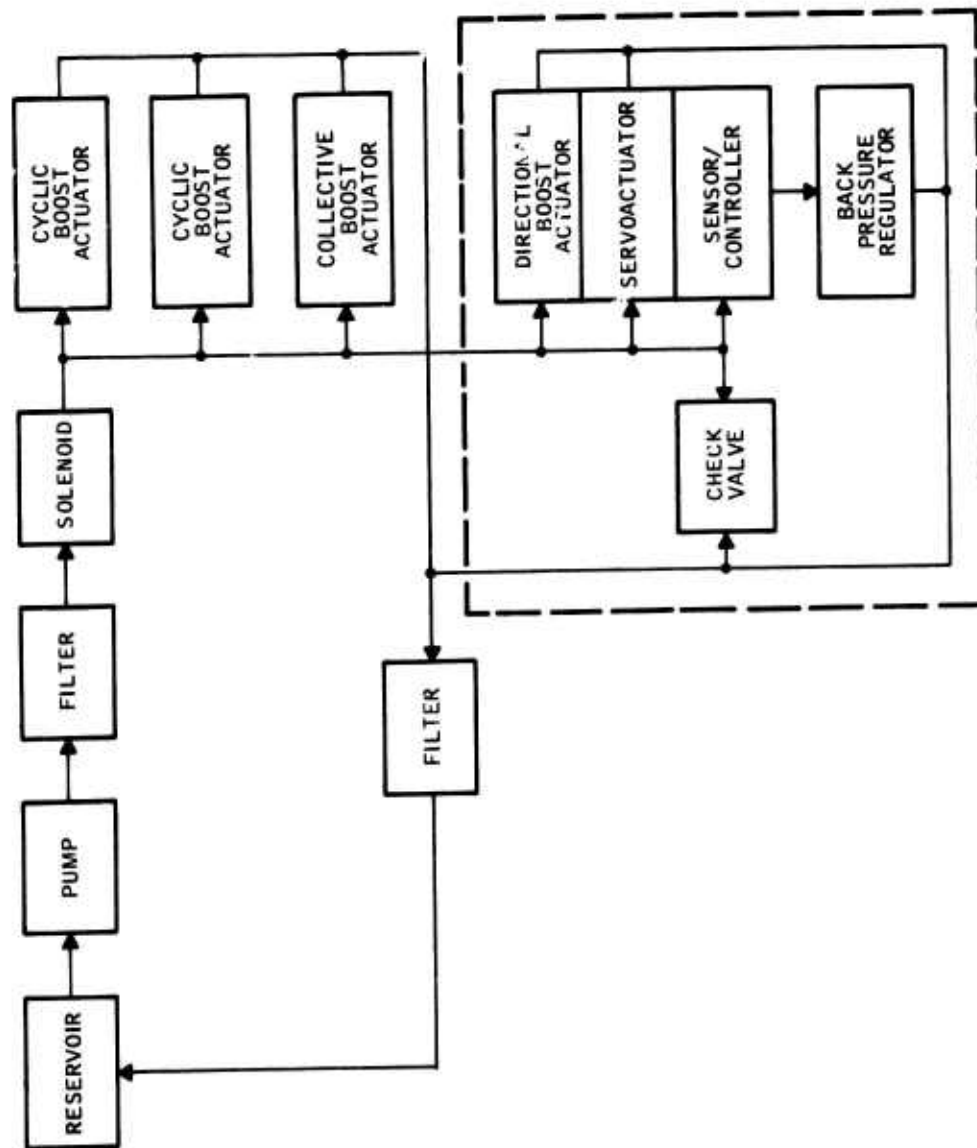

Figure 17. Block Diagram of the Hydraulic System.

The new lines were connected into the existing system at the return filter and at the shutoff solenoid. These connections can be seen in Figure 18. The lines were routed down the left side of the vehicle as shown in Figures 19, 20, and 21. In the engine compartment the lines angled along the floor to approximately the center of the vehicle as shown in Figure 22, and at station 164.00 they passed through the engine compartment floor. The supply line and actuator return line connected directly to the system through flexible hoses. The sensor/controller return line connected to the back pressure regulator by rigid tubing and then to the sensor/controller through a flexible line. These connections are shown in Figure 11.

Boost Actuator Oscillation

During the flight test of the YG1105A01 system, a condition occurred that caused the directional boost actuator to oscillate. A fixture was placed on the pedals that would restrict their motion. This fixture was rigidly attached to the airframe. When a controlled input to the aircraft was applied by the pilot, he would rapidly move the pedal against the test fixture. At various times this rapid motion and sudden artificial stopping of the pedals would shock the directional boost actuator and cause it to oscillate (buzz). As soon as the pedal was removed from the test fixture, the oscillation stopped. This oscillation could be induced on the ground by manually forcing the pedals against the stops. It occurred with the SAS engaged or disengaged.

When the YG1116A01 system was flight tested, this phenomenon did not occur. Attempts were made to induce it, but only with the SAS engaged and only after repeated attempts could the boost actuator be made to oscillate.

It is believed that the weight of the SAS assembly is the major factor that will cause the boost actuator to oscillate when the pedals are jammed against the test fixture or the pedal stops.

The problem will be investigated again during the roll axis flight test program under contract DAAJ02-73-C-0056.

INSTRUMENTATION

Pilot Input Signal Instrumentation

In order to determine the pilot's inputs, potentiometers were installed on the pedals, the cyclic, and the collective. The pedal potentiometer was located in front of the pilot's pedals as shown in Figure 23, the cyclic potentiometers were located under the pilot's seat as shown in Figure 24,

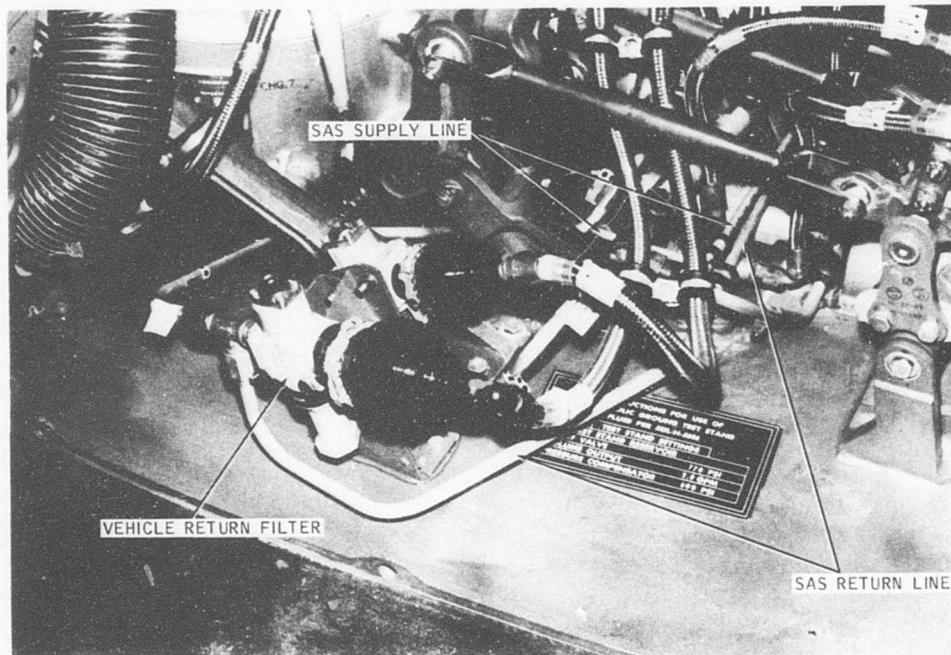

Figure 18. Supply and Return Connected Into OH-58A Hydraulic System.

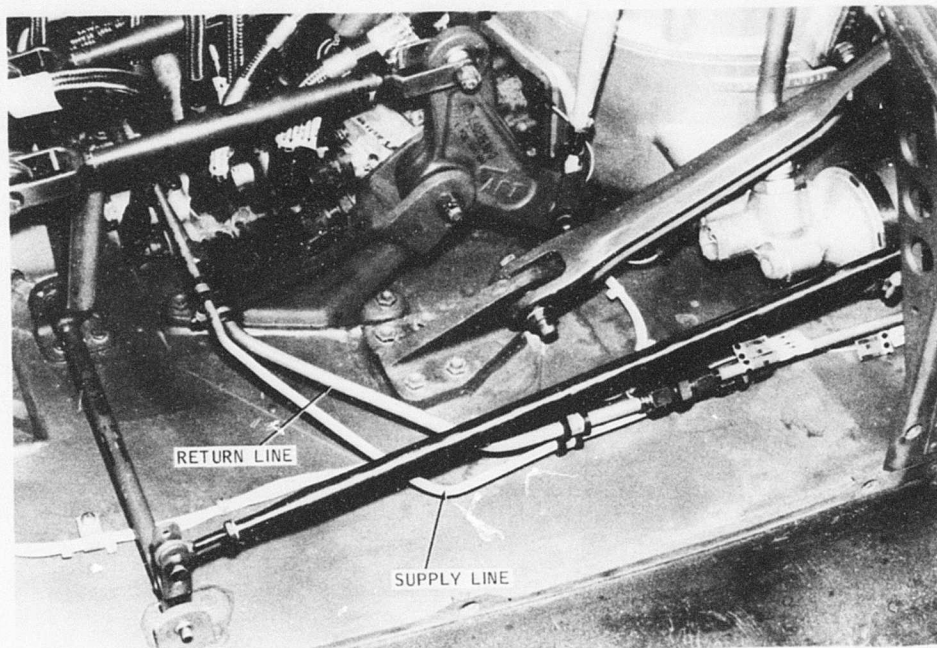

Figure 19. Routing Along Left Side of OH-58A.

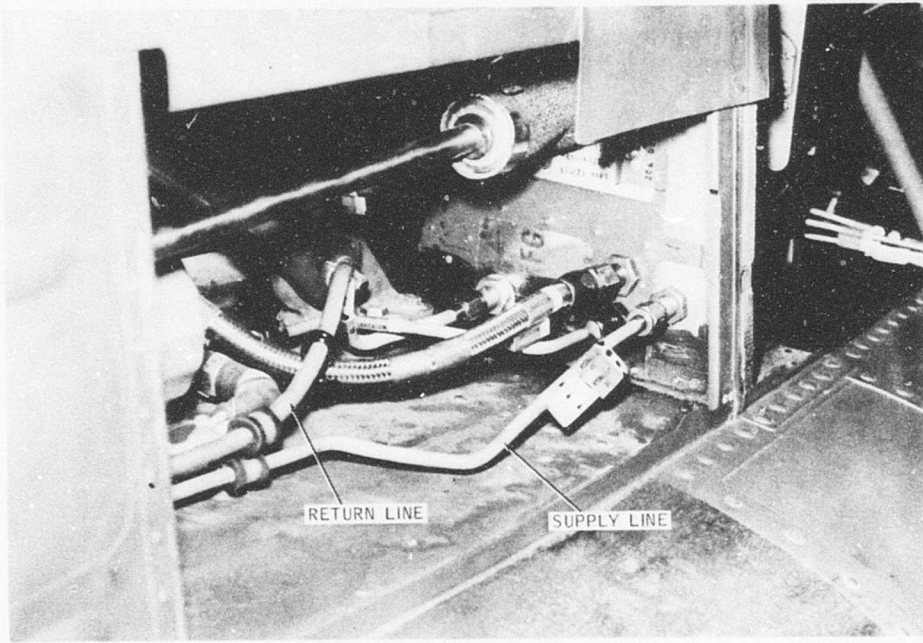

Figure 20. View Looking Rearward at Approximately Station 125.00.

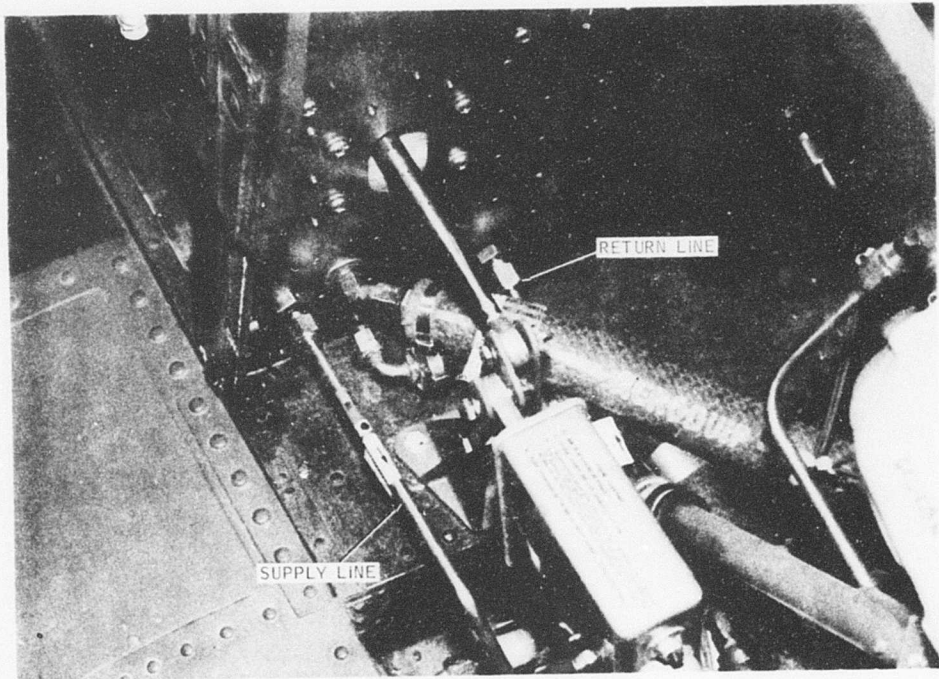

Figure 21. View Looking Forward at Approximately Station 125.00.

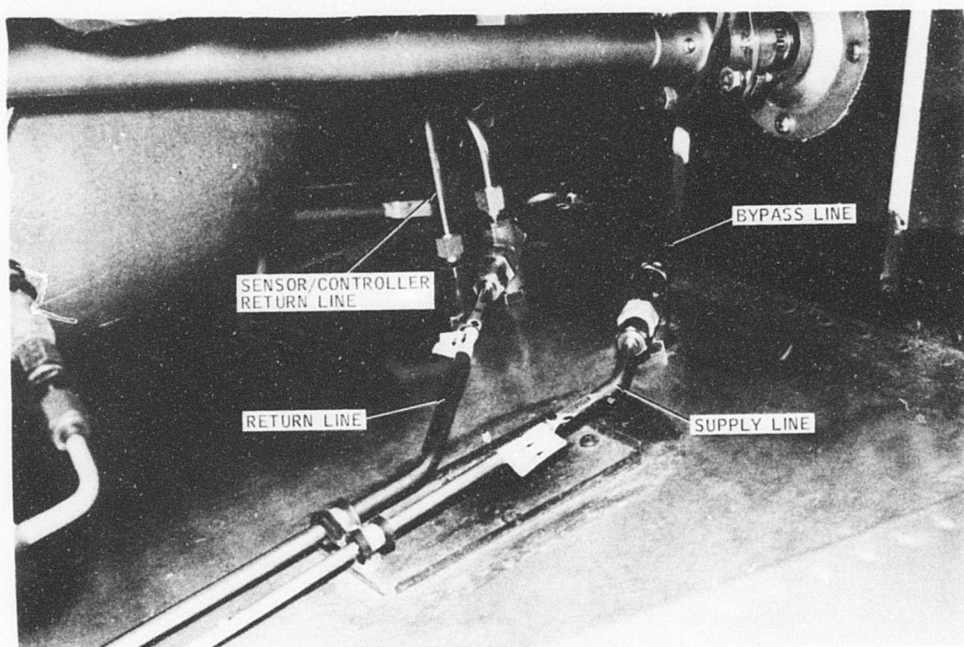

Figure 22. View Looking Below Engine Where Hydraulic Lines Enter Baggage Area.

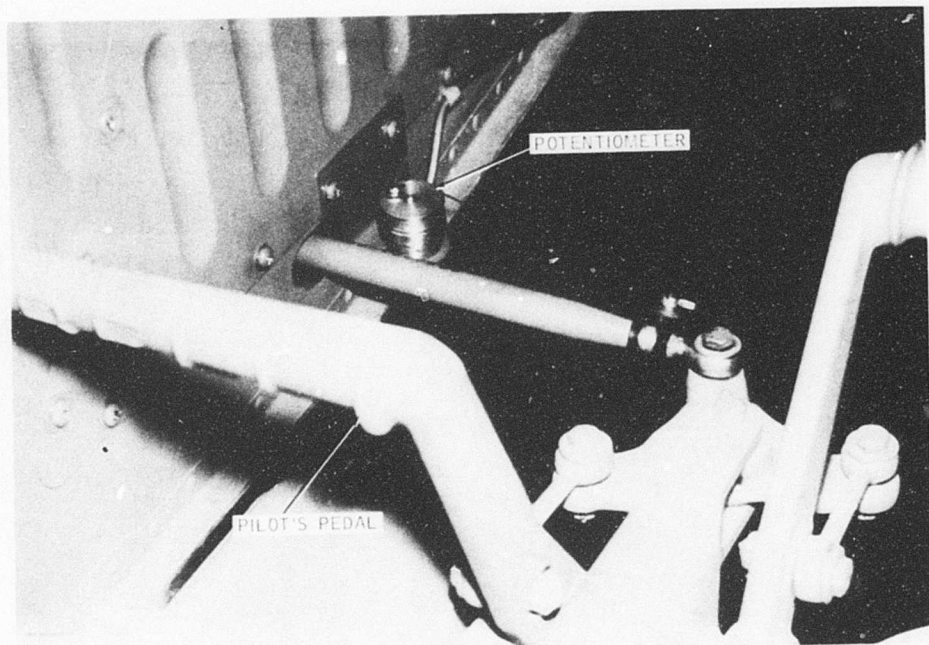

Figure 23. Pedal Pickoff - Right Side of Oh-58A.

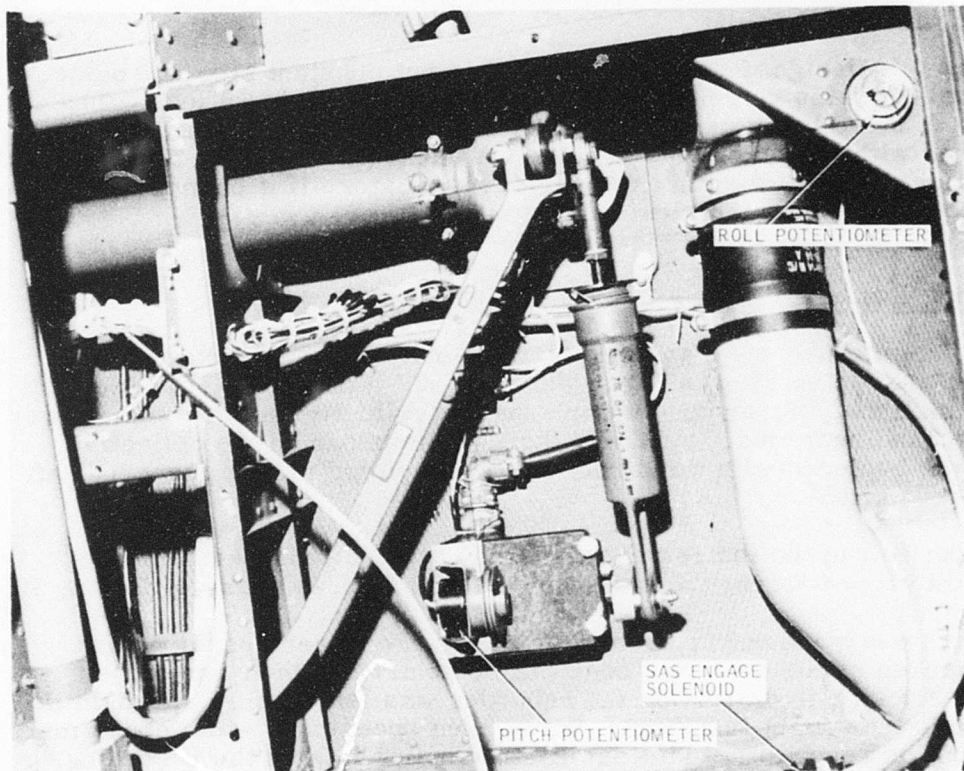

Figure 24. Roll and Pitch Cyclic Pickoff Under Pilot Seat.

and the collective potentiometer was located under the copilot's seat as shown in Figure 25. The pedal and cyclic potentiometers were spring loaded such that a simple nylon string could be used to connect the potentiometers to the control linkages. This eliminated any binding or misalignment, especially on cyclic controls that move in multidirections.

Flight Test Fixture

A fixture was designed enabling the pilot to put constant step and pulse type inputs into the vehicle controls. This device is shown in Figures 26 and 27. It could be adjusted to control the size of the steps and also positioned with respect to the vehicle. A shear pin fastening the rod to the end piece allows the pilot to override the fixture if it cannot be removed from the controls quickly.

Recording Equipment

The vehicle motion was measured by three rate gyros: pitch, roll, and yaw. These can be seen in Figures 28 and 29. The rate gyros, the pilot control motions, the servoactuator, and the collective motion signals were amplified and recorded. Part way through the program the collective signal was replaced with the directional control rod motion measured aft of the boost actuator.

The power to run the instrumentation was obtained from the vehicle's armament circuit through a 400 Hz inverter, which is shown in Figure 30.

The instrumentation power, recorder power, recorder speed, and an event marker on the recorder could all be controlled from the center console. During flight testing the recorder was left on slow speed until the time to take flight test data. It was then speeded up and a coded mark placed on the recording. This facilitated finding data on the recordings and correlated the recordings with airspeed and direction.

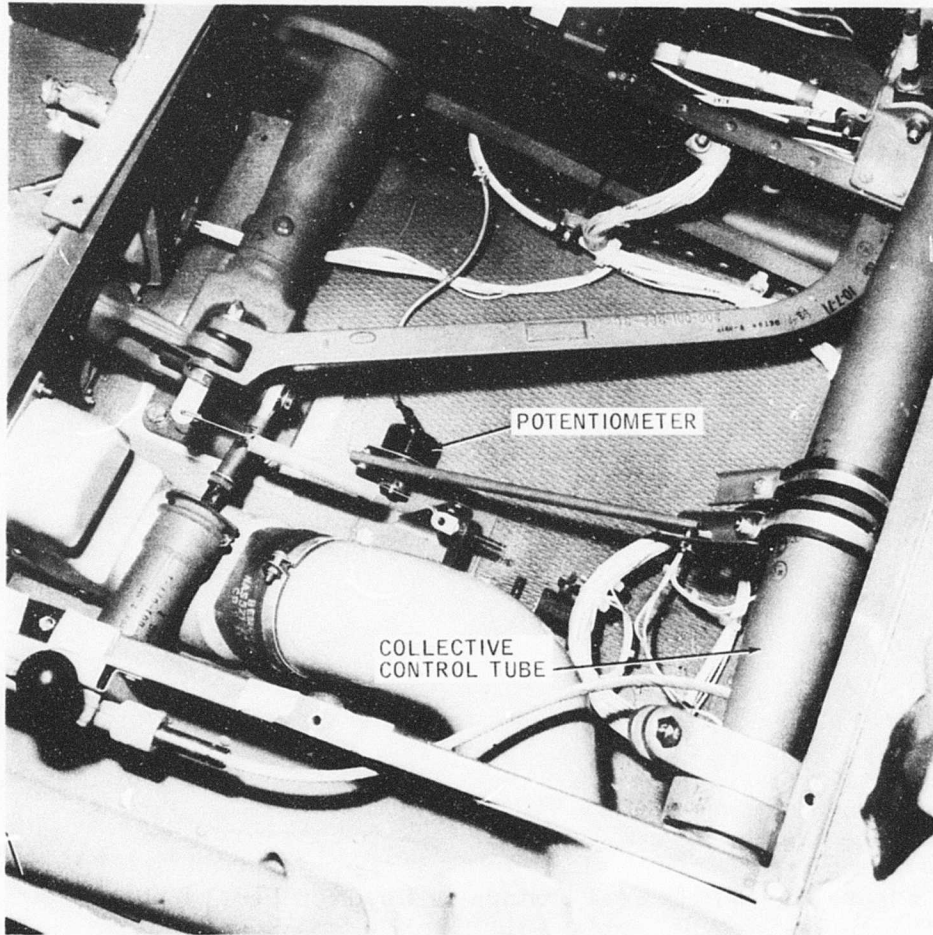

Figure 25. Collective Pickoff Under Copilot Seat.

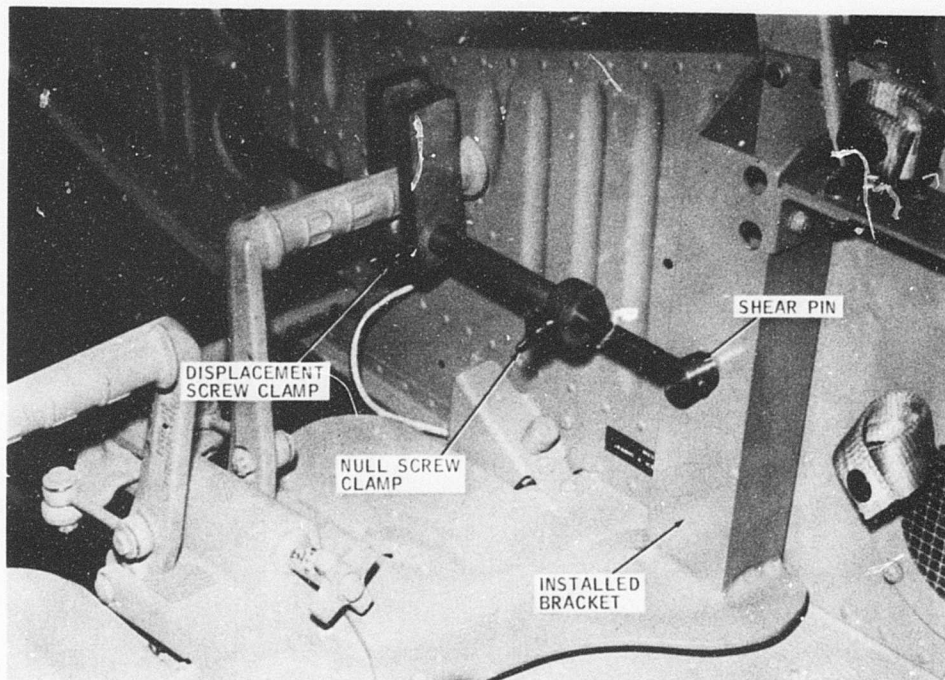

Figure 26. Flight Test Fixture as Used for Pedal Inputs.

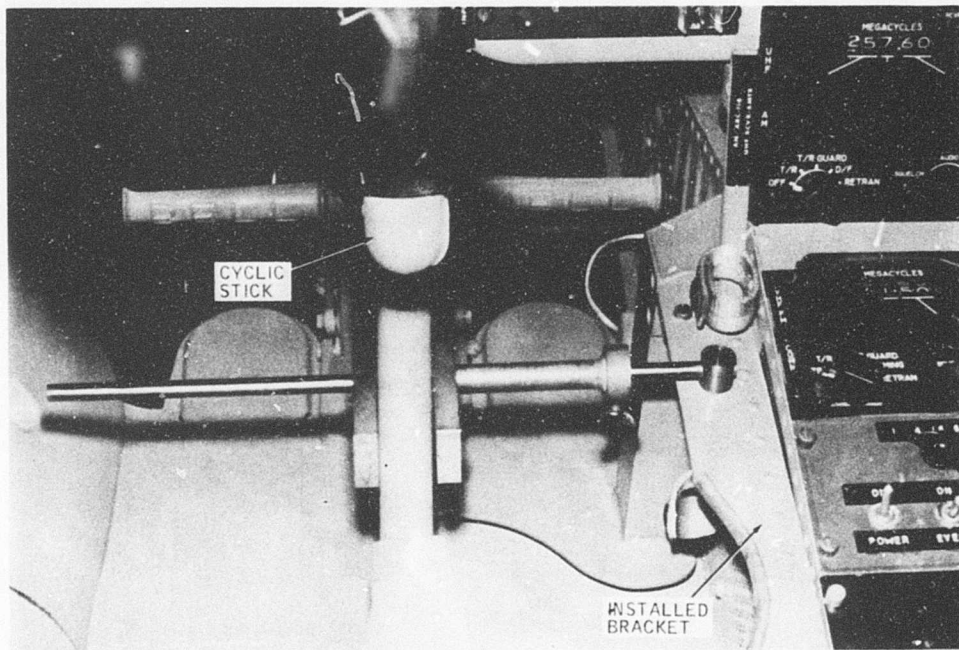

Figure 27. Flight Test Fixture as Used for Roll Inputs.

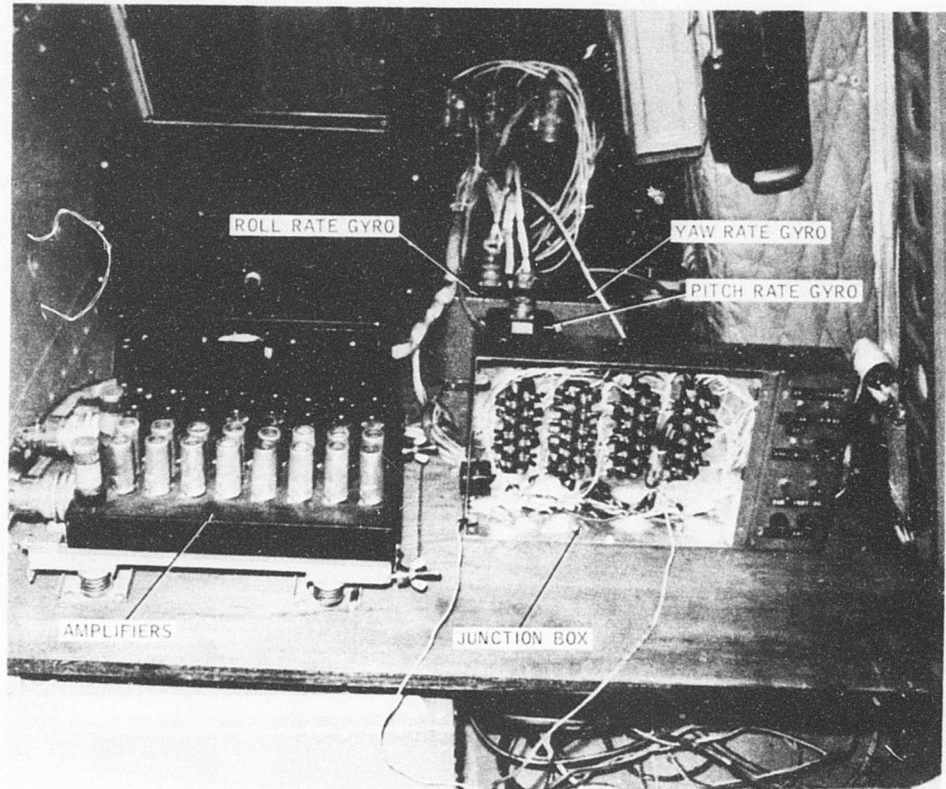

Figure 28. Test Instrumentation as Viewed From Right Side of OH-58A.

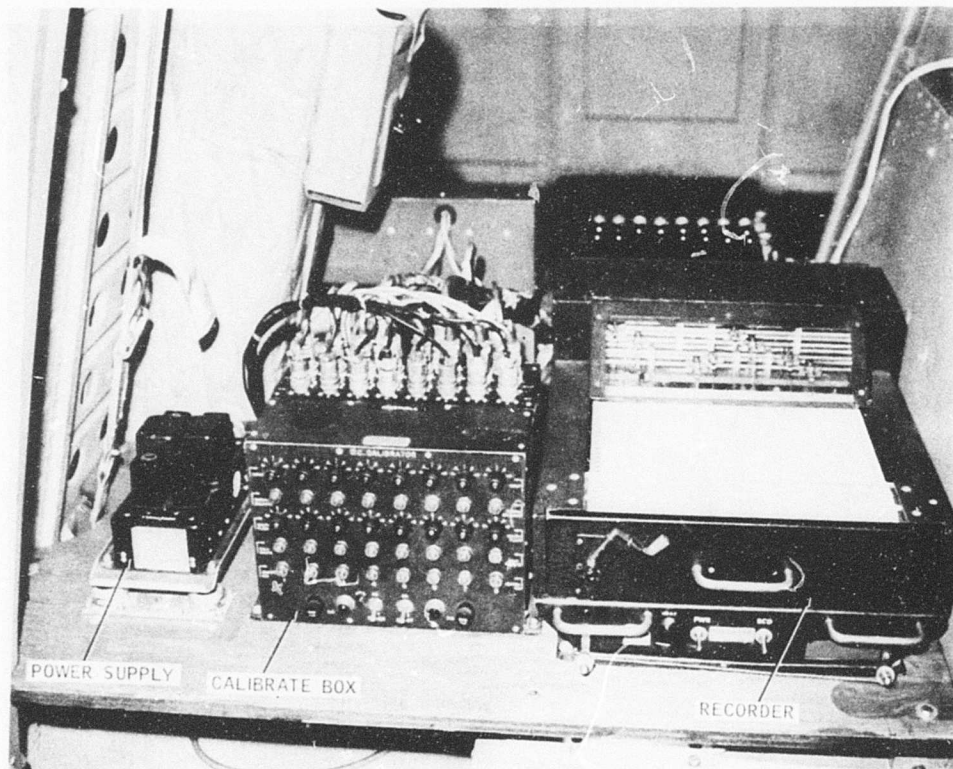

Figure 29. Test Instrumentation as Viewed From Left Side of OH-58A.

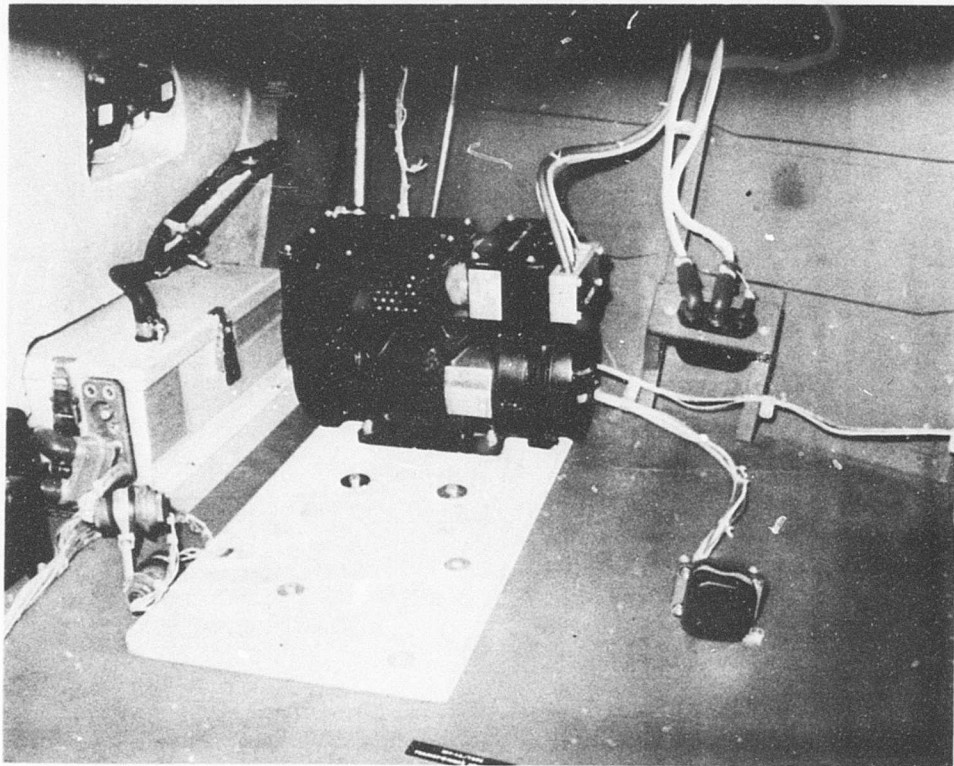

Figure 30. 400 Hz Inverter Mounting.

FLIGHT TEST RESULTS

Flight testing of the high-passed yaw rate configuration was completed in October 1972, and that of the high-passed plus straight-through yaw rate configuration in December 1973. All flight testing was conducted at the Honeywell flight operation facility at prescribed speeds and altitudes.

In order to test the effectiveness of the yaw SAS, both steps and pulses of either sign were applied for each flight condition with the yaw SAS disengaged and then repeated with the yaw SAS engaged. Appropriate parameters were recorded on an onboard 24-channel recorder. Eight of these 24 parameters were also recorded in greater detail on a second onboard eight-channel recorder. Selected segments of the eight-channel recordings are reproduced as Figures 31 through 74. These recordings were evaluated according to the criteria established in MIL-H-8501A, Amendment 1, dated April 3, 1962. Results of the evaluation, keyed to specific paragraphs of MIL-H-8501A, are summarized in tables and in the following comments.

DIRECTIONAL CONTROL POWER

Directional control power requirements are given in paragraphs 3.3.5 and 3.3.7 of MIL-H-8501A. It states that at hover for an aircraft gross weight of 2,470 pounds a 1-inch step of pedal shall result in a yaw displacement of 7.27 degrees minimum and 50.0 degrees maximum at the end of 1 second.

Results, summarized in Table II, show that the directional control power requirement is satisfied with either SAS configuration or with no SAS. Because of yaw rate feedback, some decrease in control power with the SAS on was expected. Data indicated, however, that neither SAS consistently increased or decreased control power.

Change in heading was obtained by integration of yaw rate, since heading was not displayed on the eight-channel recorder.

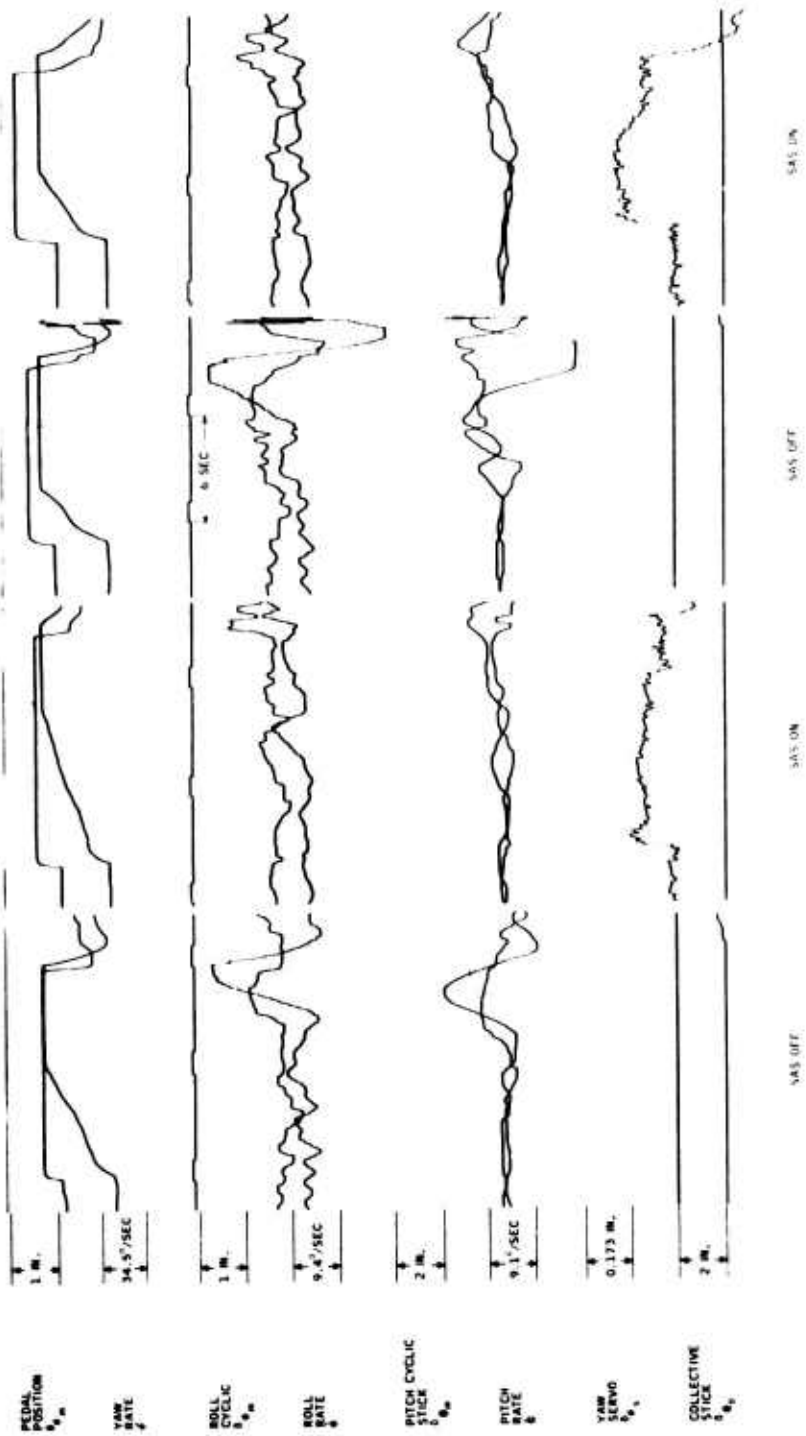

Figure 31. Yaw Step - Left (Hover, 75 Ft) No Straight-Through Yaw Rate Loop.

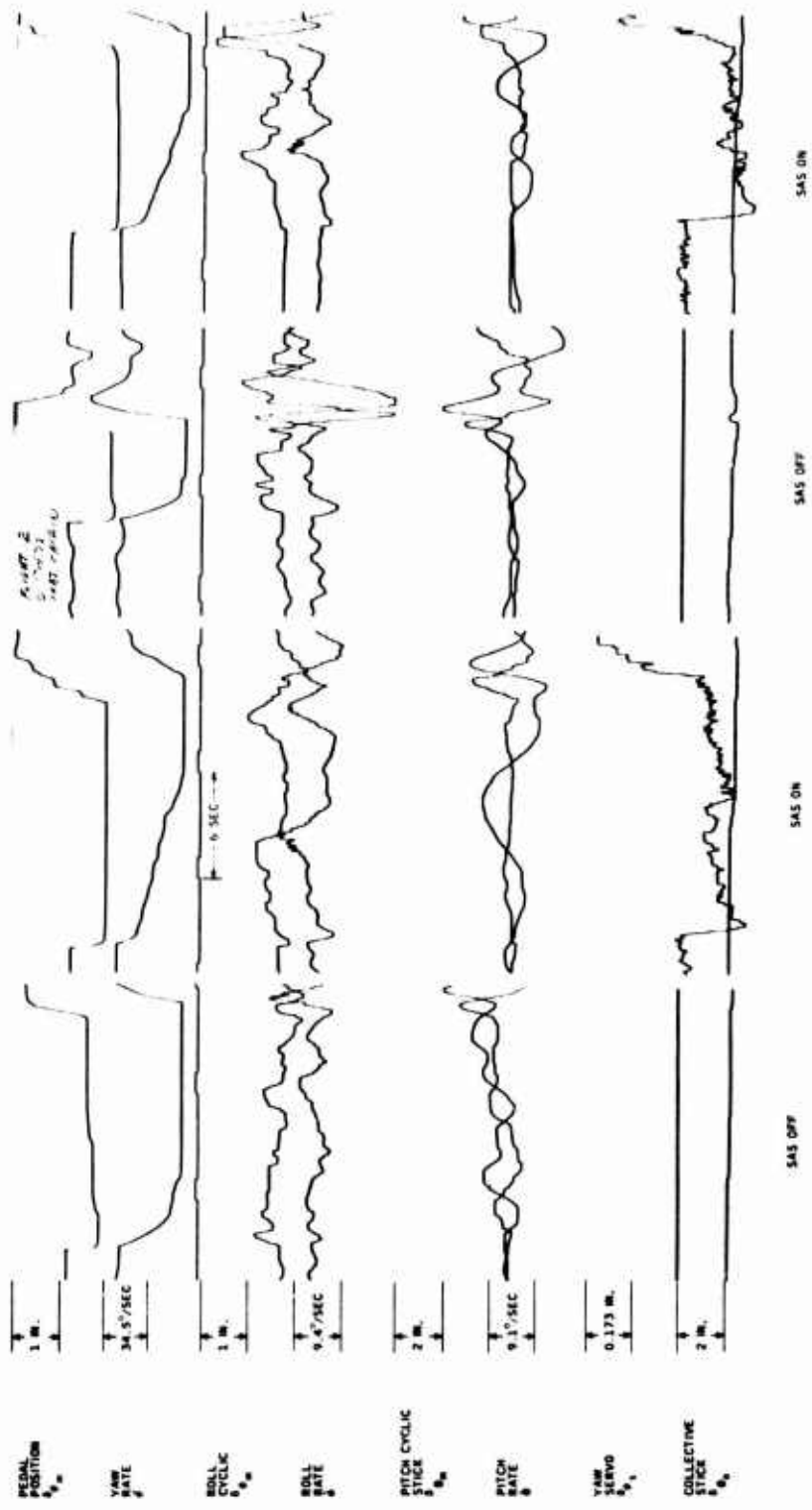

Figure 32. Yaw Step - Right (Hover, 75 Ft) No Straight-Through Yaw Rate Loop.

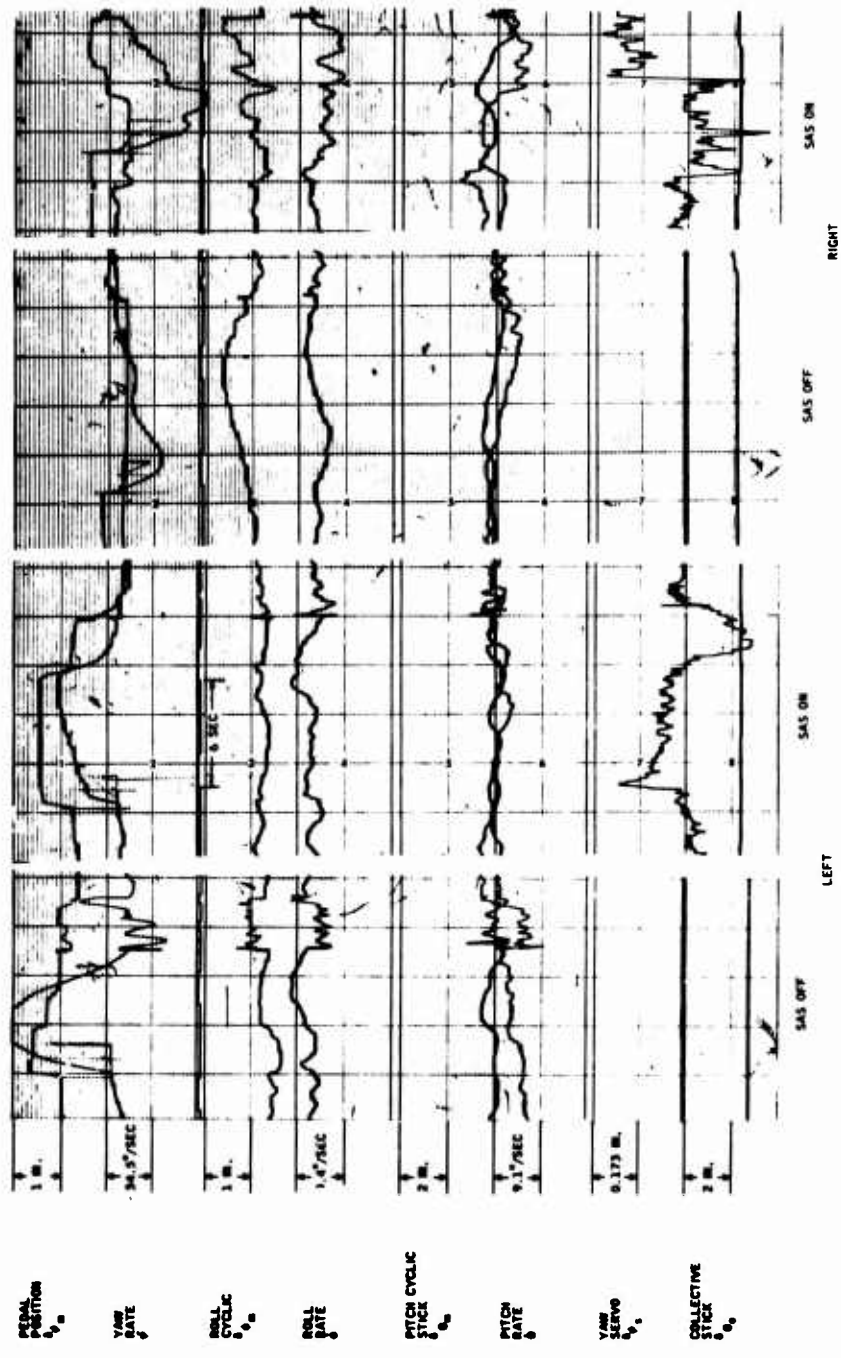

Figure 33. Yaw Steps (Hover, 3,000 Ft) No Straight-Through Yaw Rate Loop.

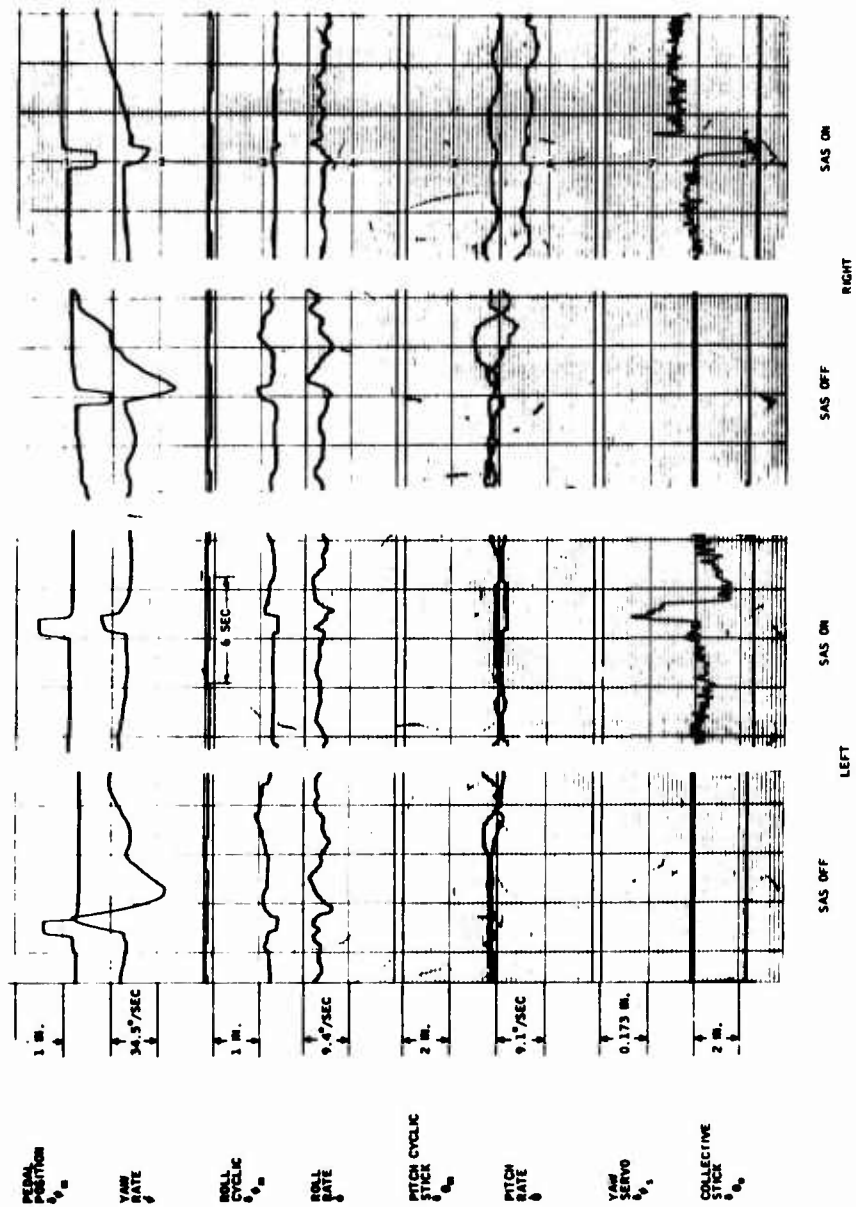

Figure 34. Yaw Pulses (Hover, 3,000 Ft) No Straight-Through Yaw Rate Loop.

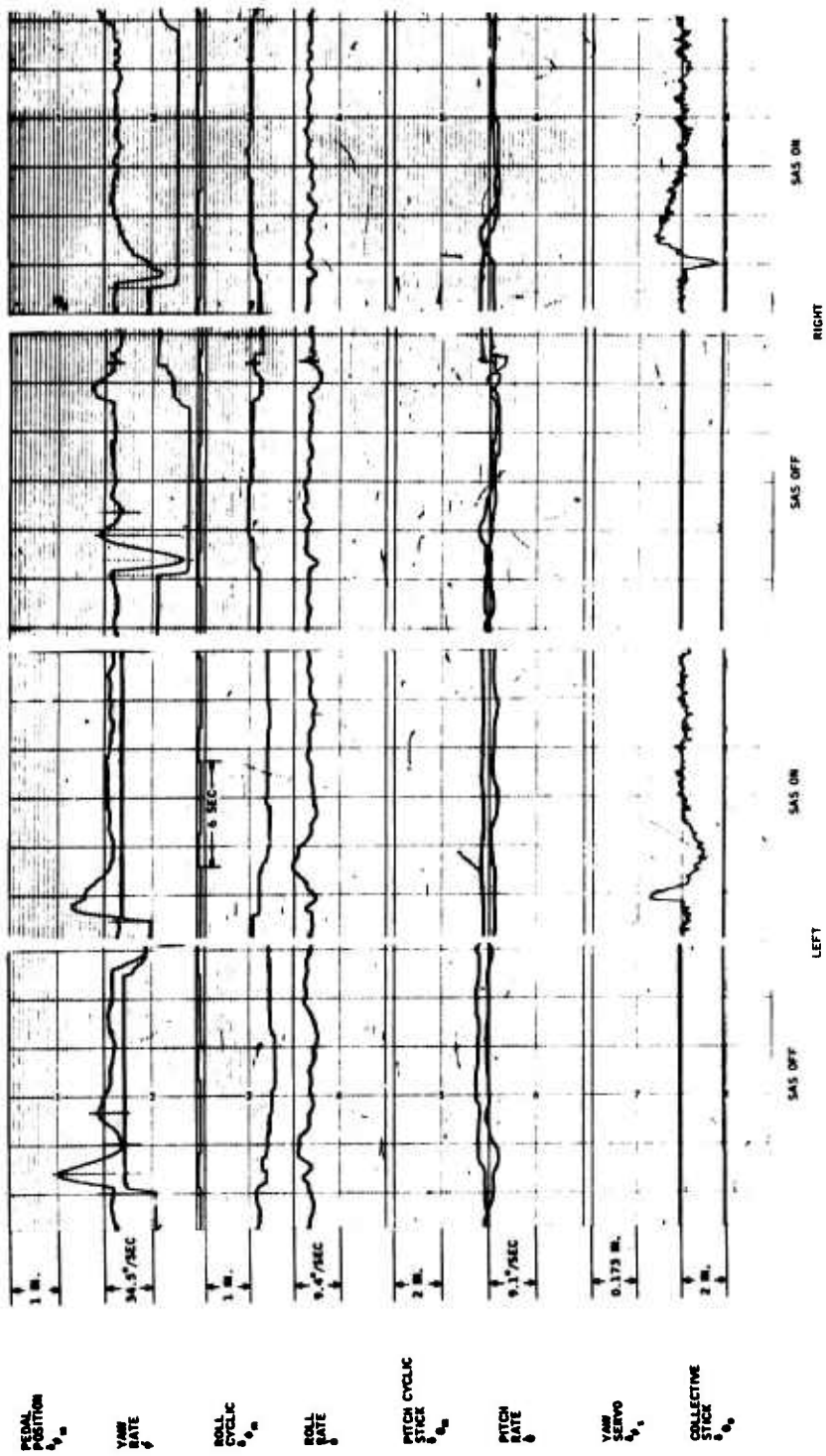

Figure 35. Yaw Steps (60 Kn, 3,000 Ft) No Straight-Through Yaw Rate Loop.

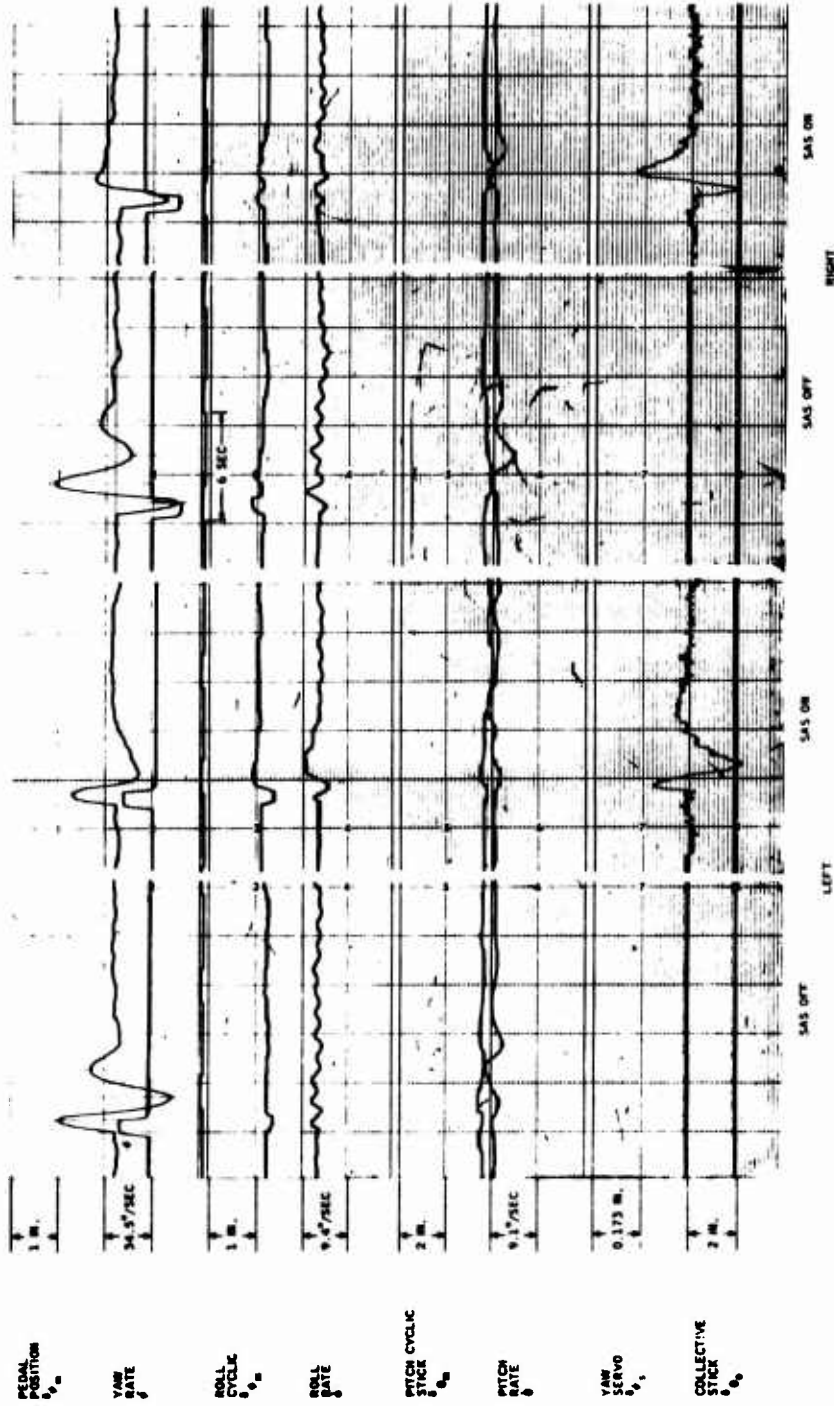

Figure 36. Yaw Pulses (60 Kn, 3,000 Ft) No Straight-Through Yaw Rate Loop.

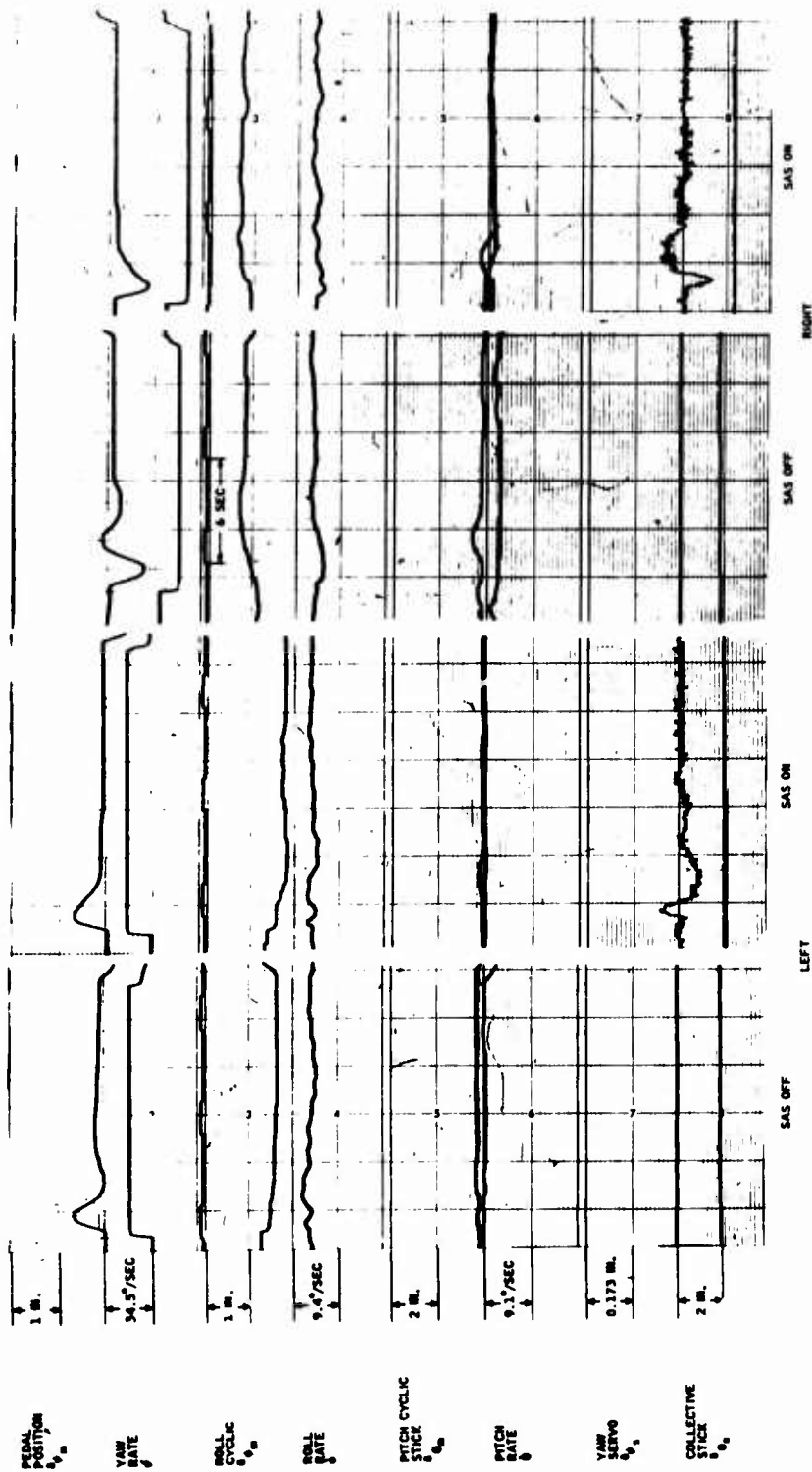

Figure 37. Yaw Steps (60 Kn, 6,000 Ft) No Straight-Through Yaw Rate Loop.

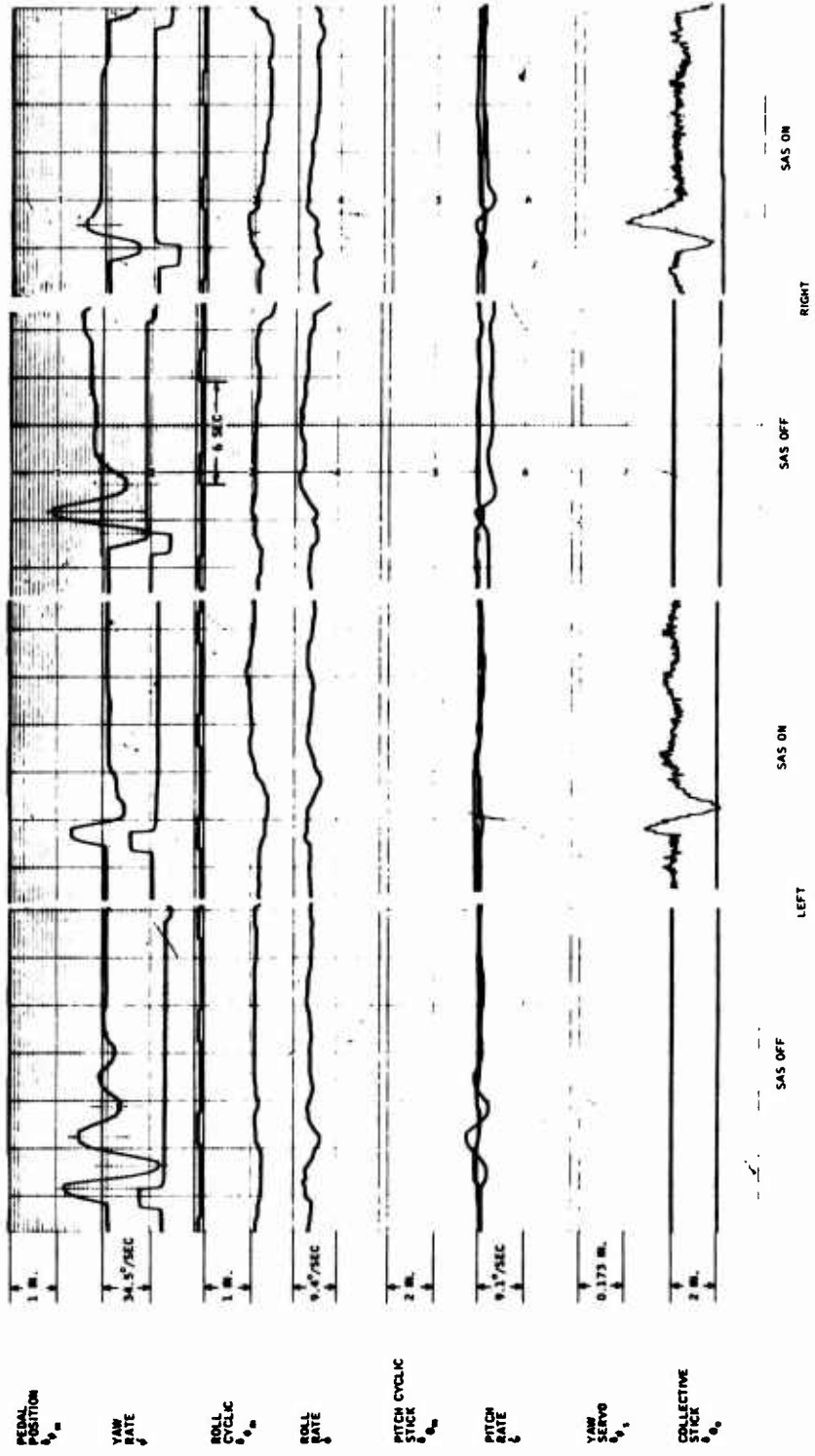
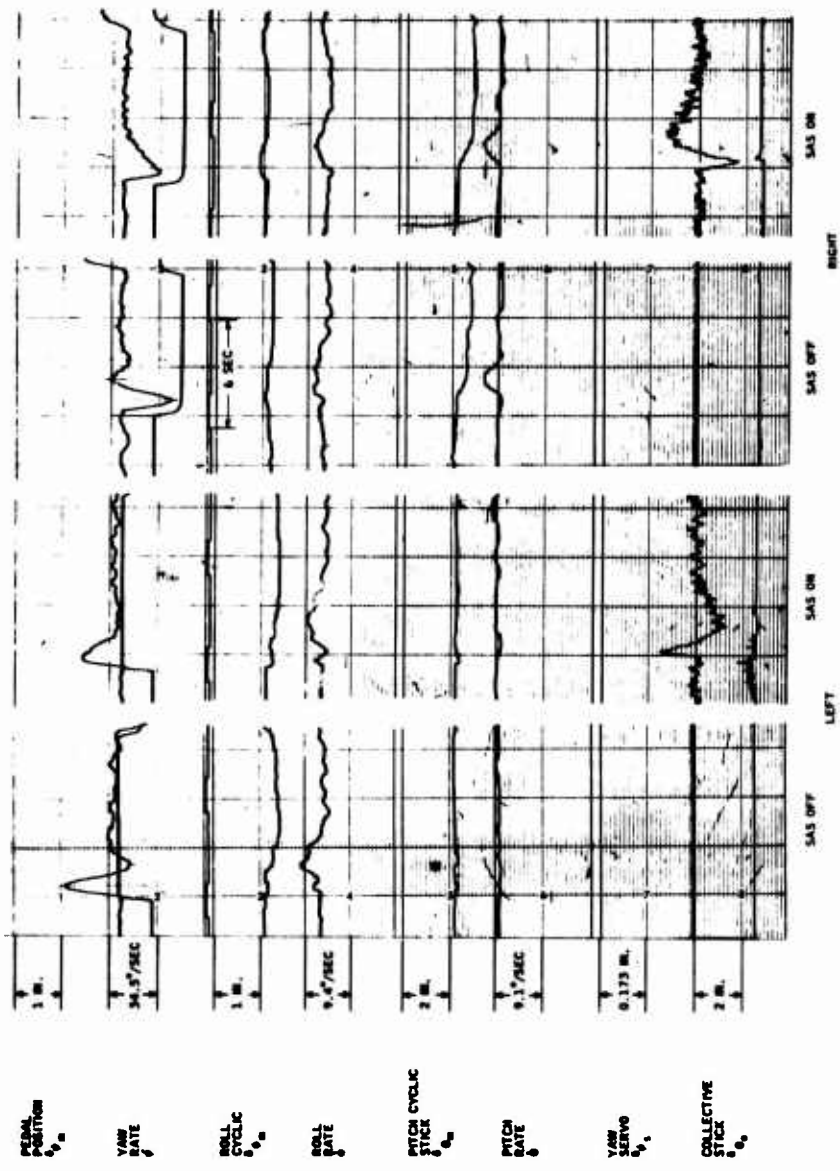

Figure 38. Yaw Pulses (60 Kn, 6,000 Ft) No Straight-Through Yaw Rate Loop.

Reproduced from best available copy.



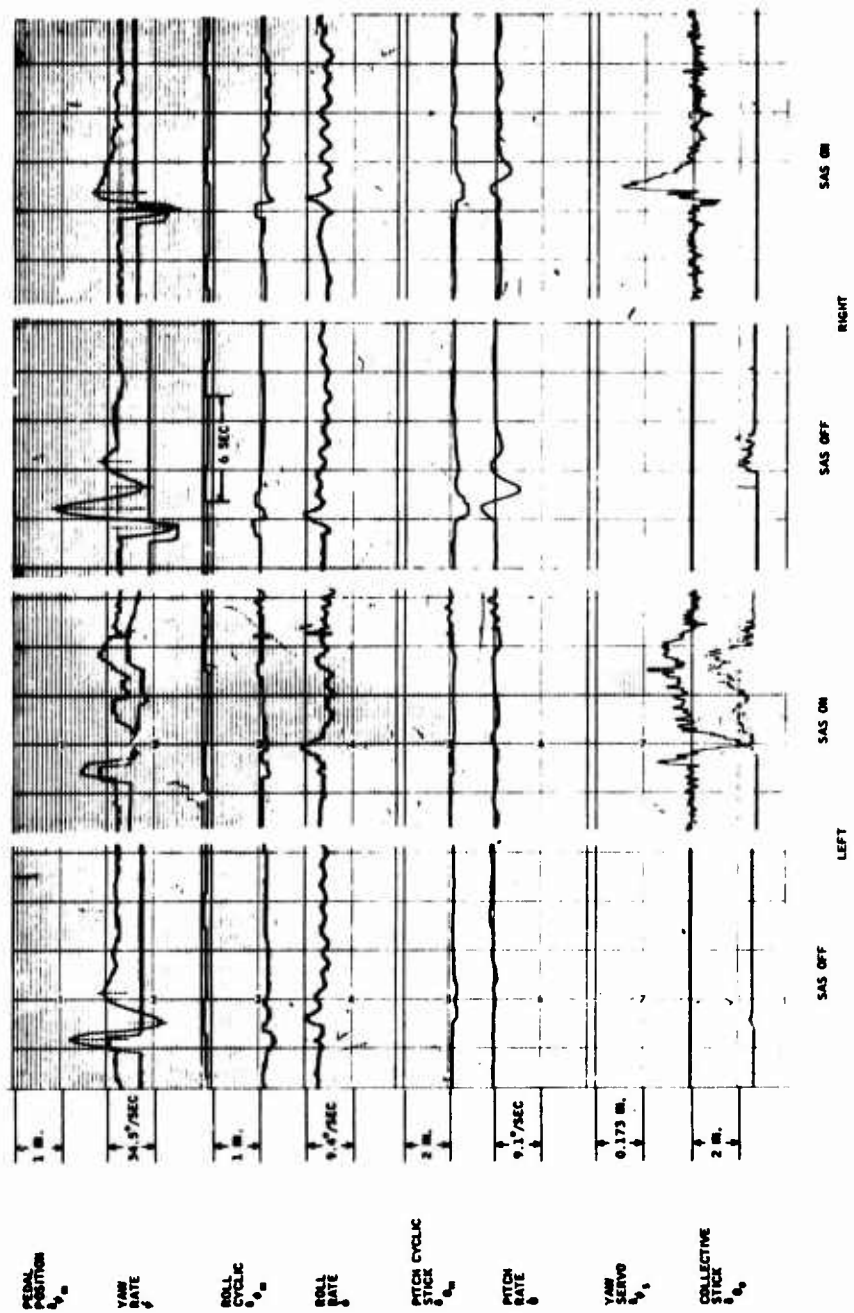

Figure 40. Yaw Pulses (90 Kn, 3,000 Ft) No Straight-Through Yaw Rate Loop.

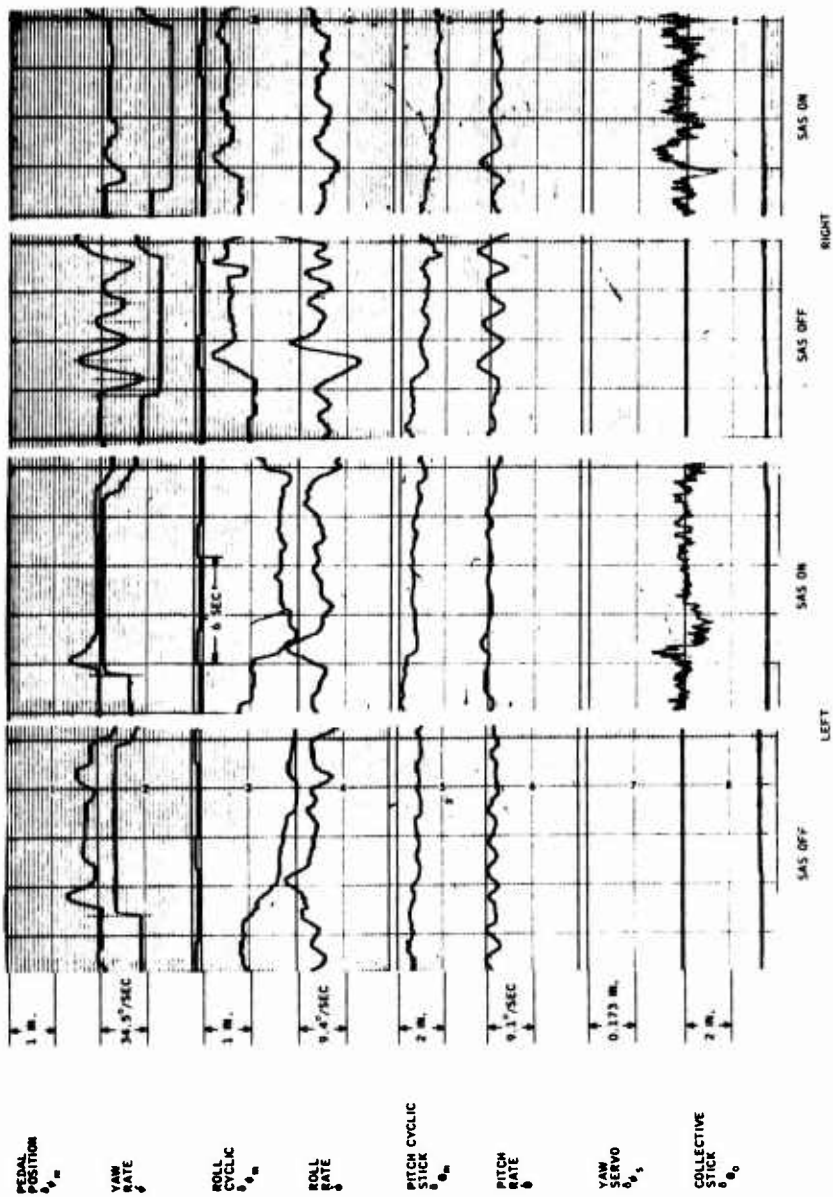

Figure 41. Yaw Steps (110 Kn, 3,000 Ft) No Straight-Through Yaw Rate Loop.

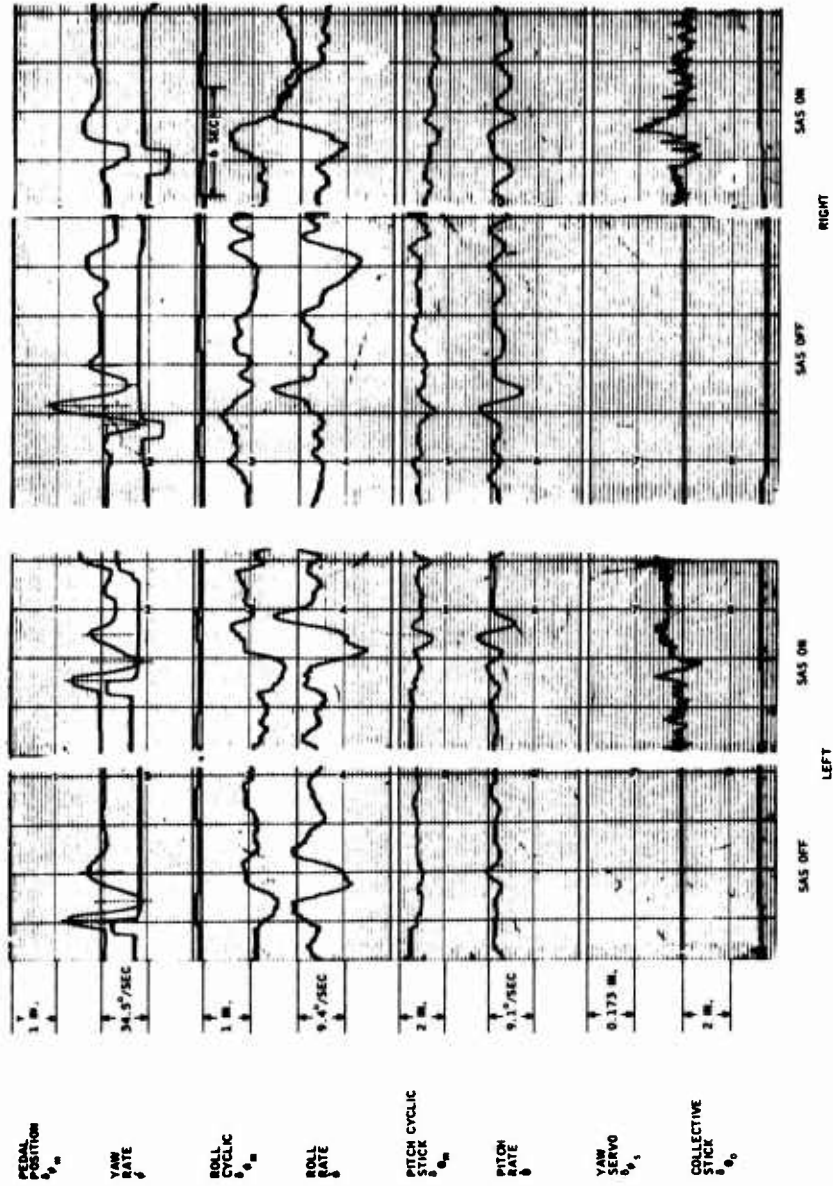

Figure 42. Yaw Pulses (110 Kn, 3,000 Ft) No Straight-Through Yaw Rate Loop.

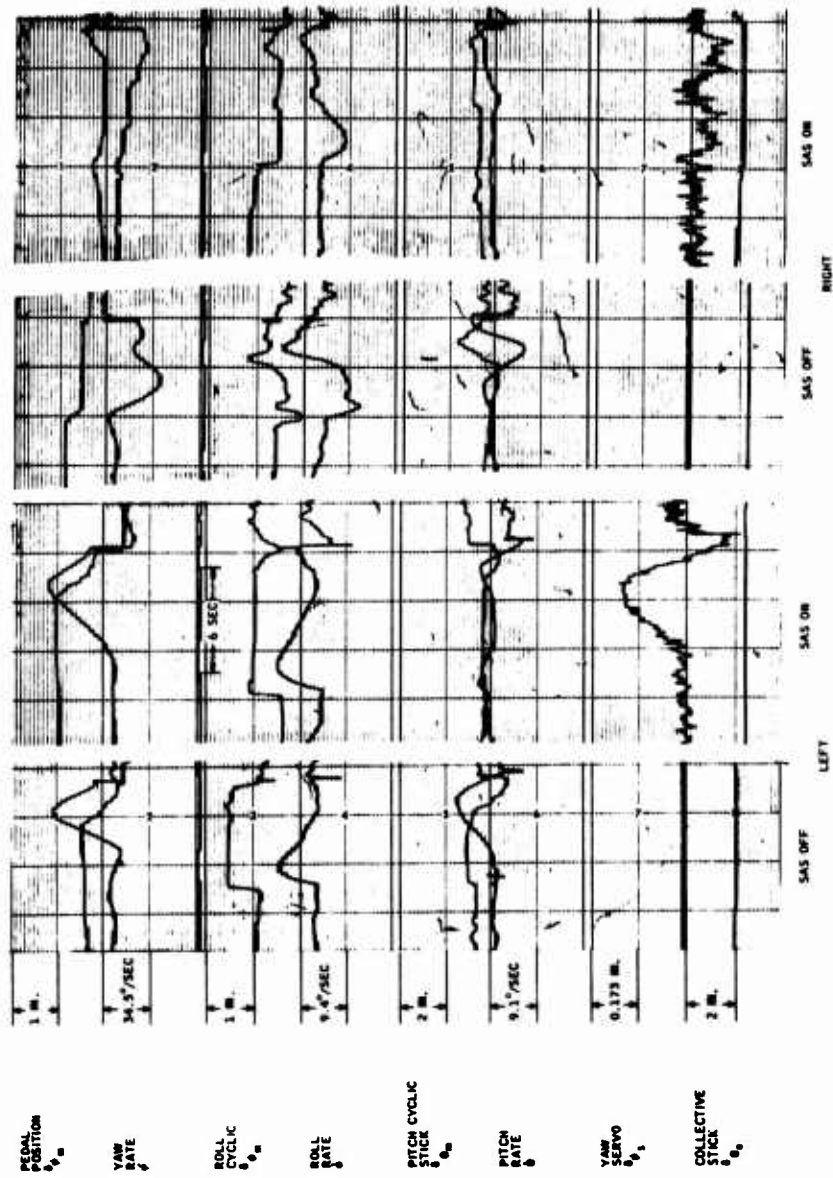

Figure 43. Roll Steps (Hover, 3,000 Ft) No Straight-Through Yaw Rate Loop.

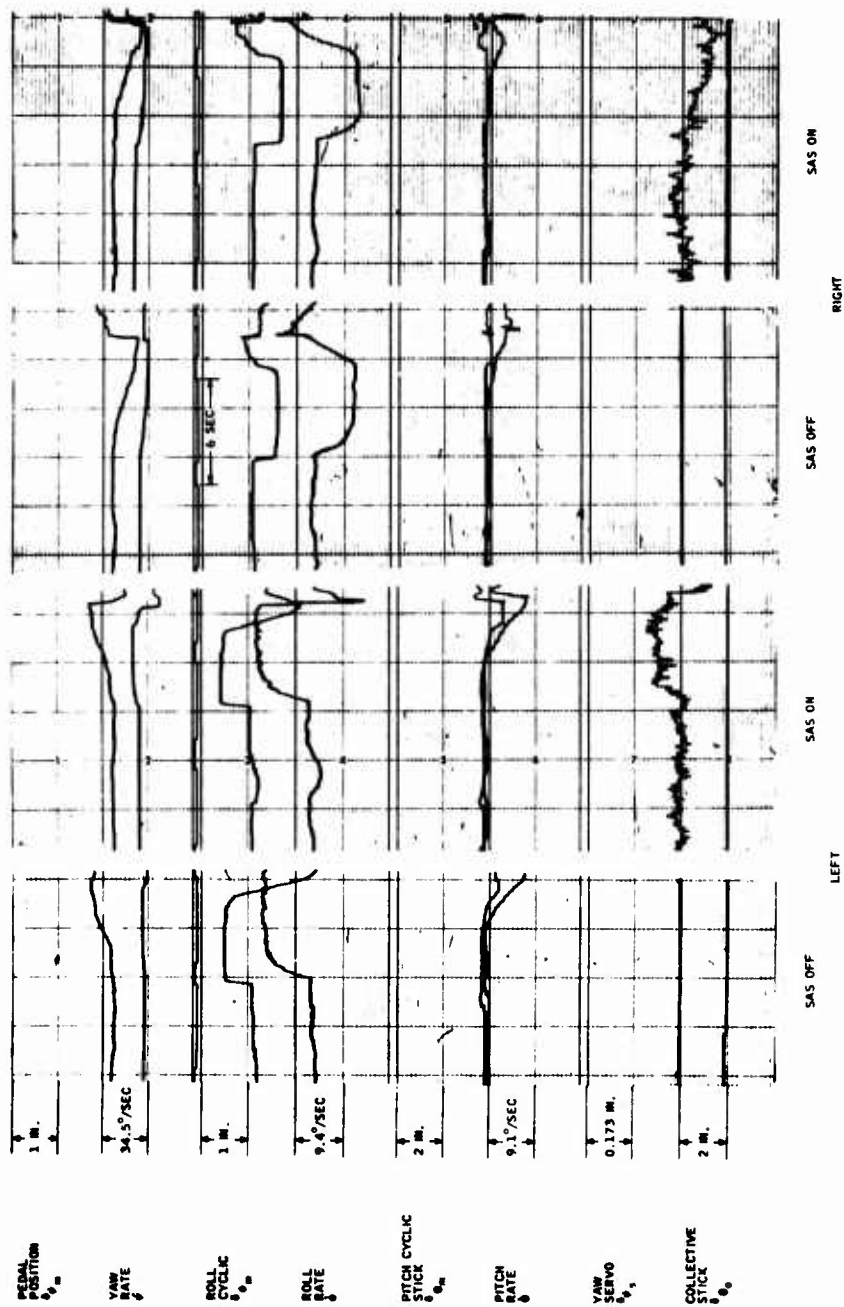

Figure 44. Roll Steps (60 Kn, 3,000 Ft) No Straight-Through Yaw Rate Loop.

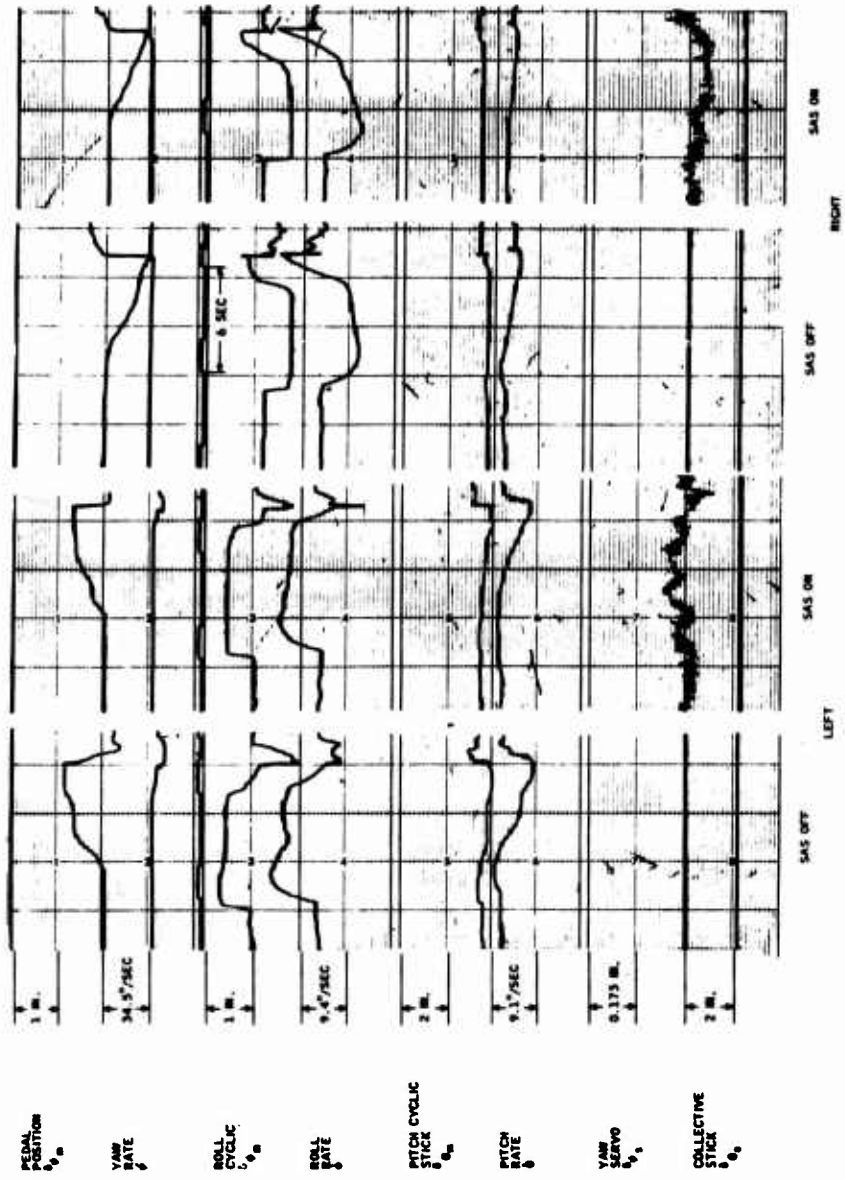

Figure 45. Roll Steps (60 Kn, 6,000 Ft) No Straight-Through Yaw Rate Loop.

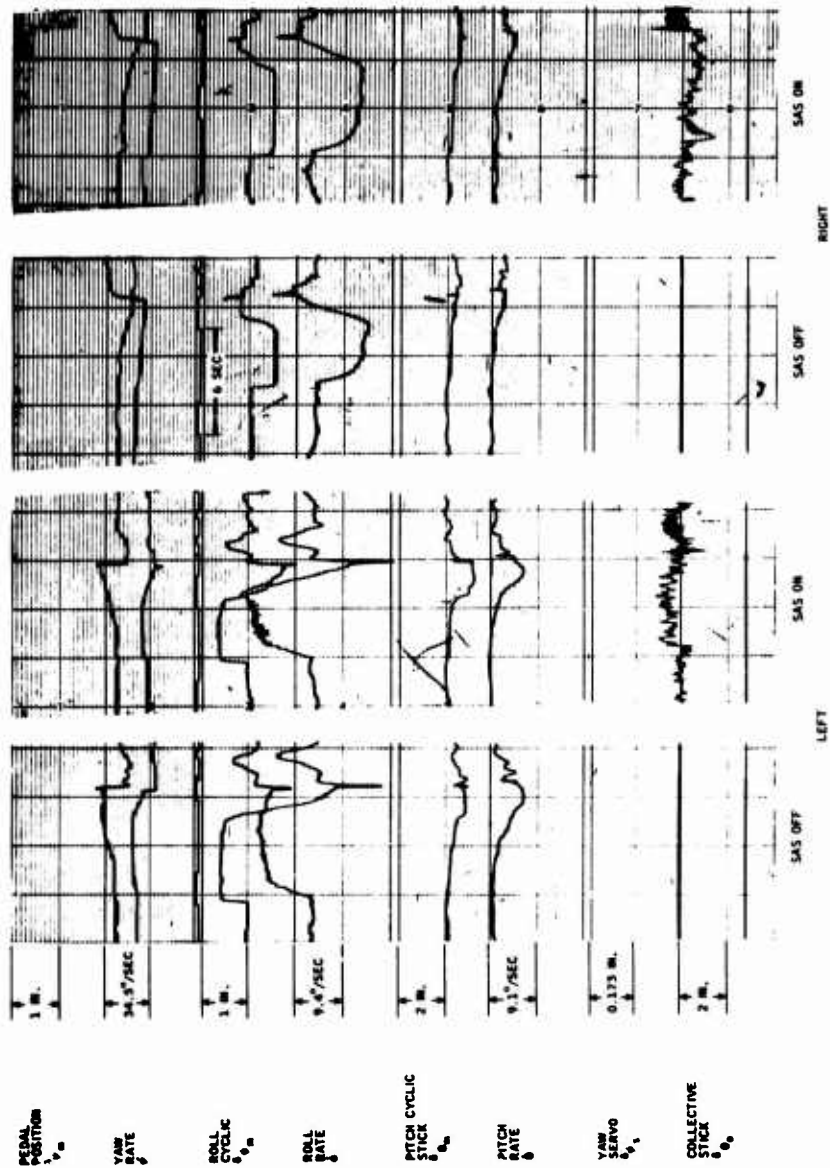

Figure 46. Roll Steps (90 Kn, 3,000 Ft) No Straight-Through Yaw Rate Loop.

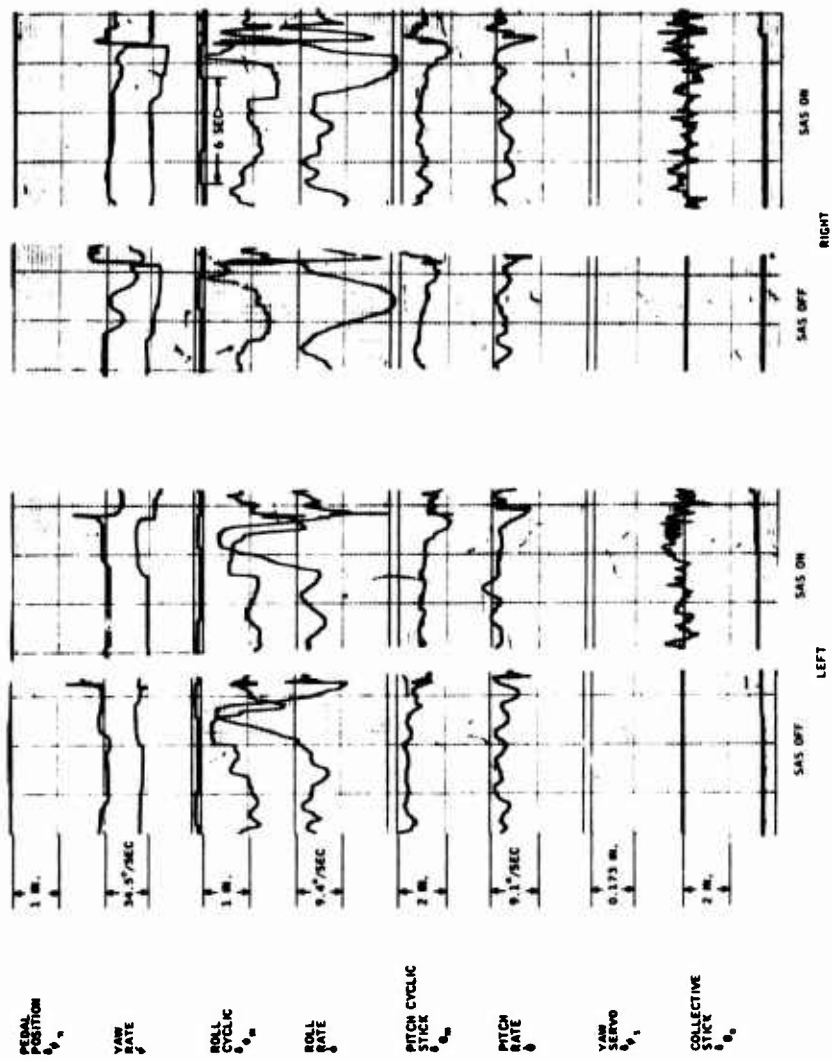

Figure 47. Roll Steps (110 Kn, 3,000 Ft) No Straight-Through Yaw Rate Loop.

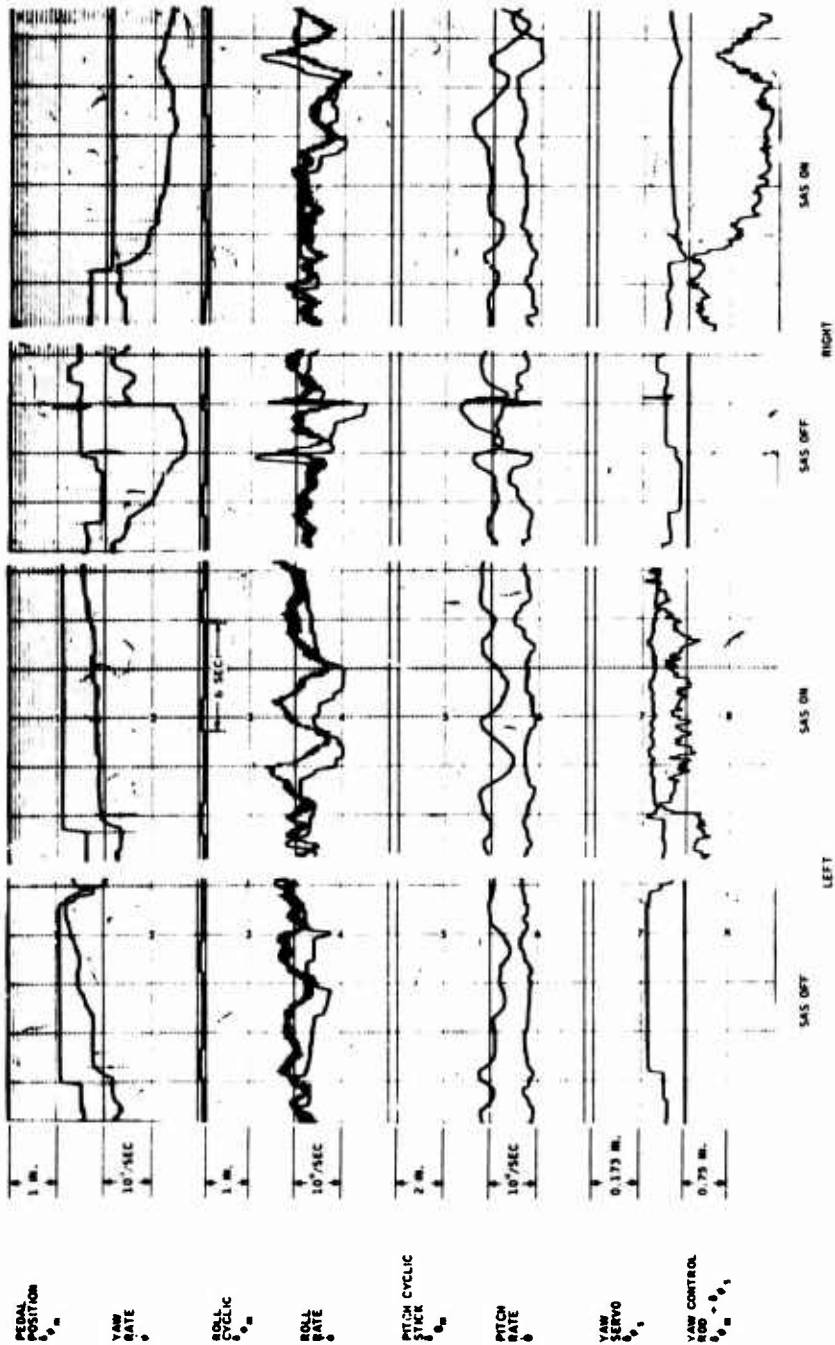

Figure 48. Yaw Steps (Hover, 5 Ft) With Straight-Through Yaw Rate Loop.

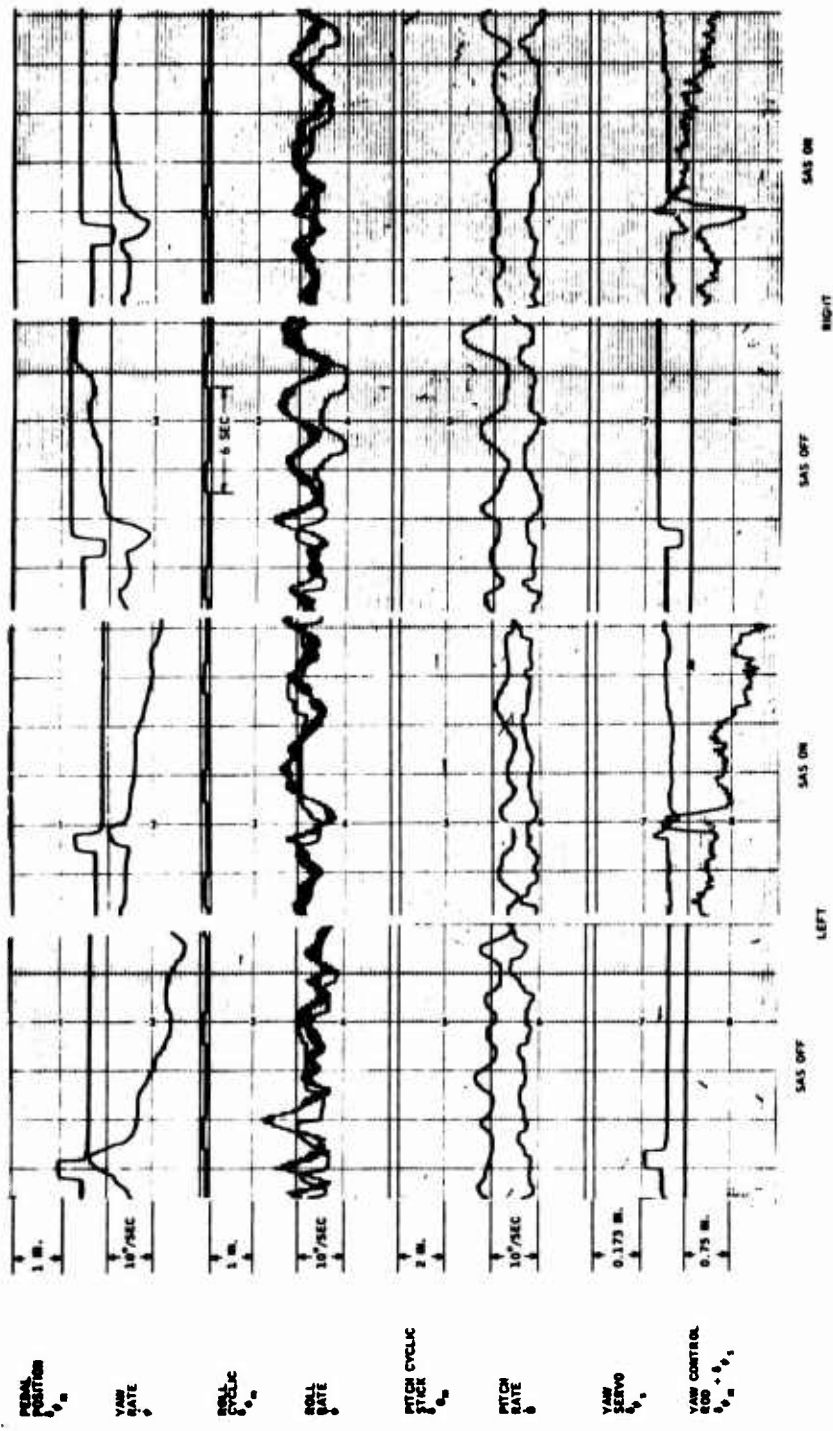

Figure 49. Yaw Pulses (Hover, 5 Ft) With Straight-Through Yaw Rate Loop.

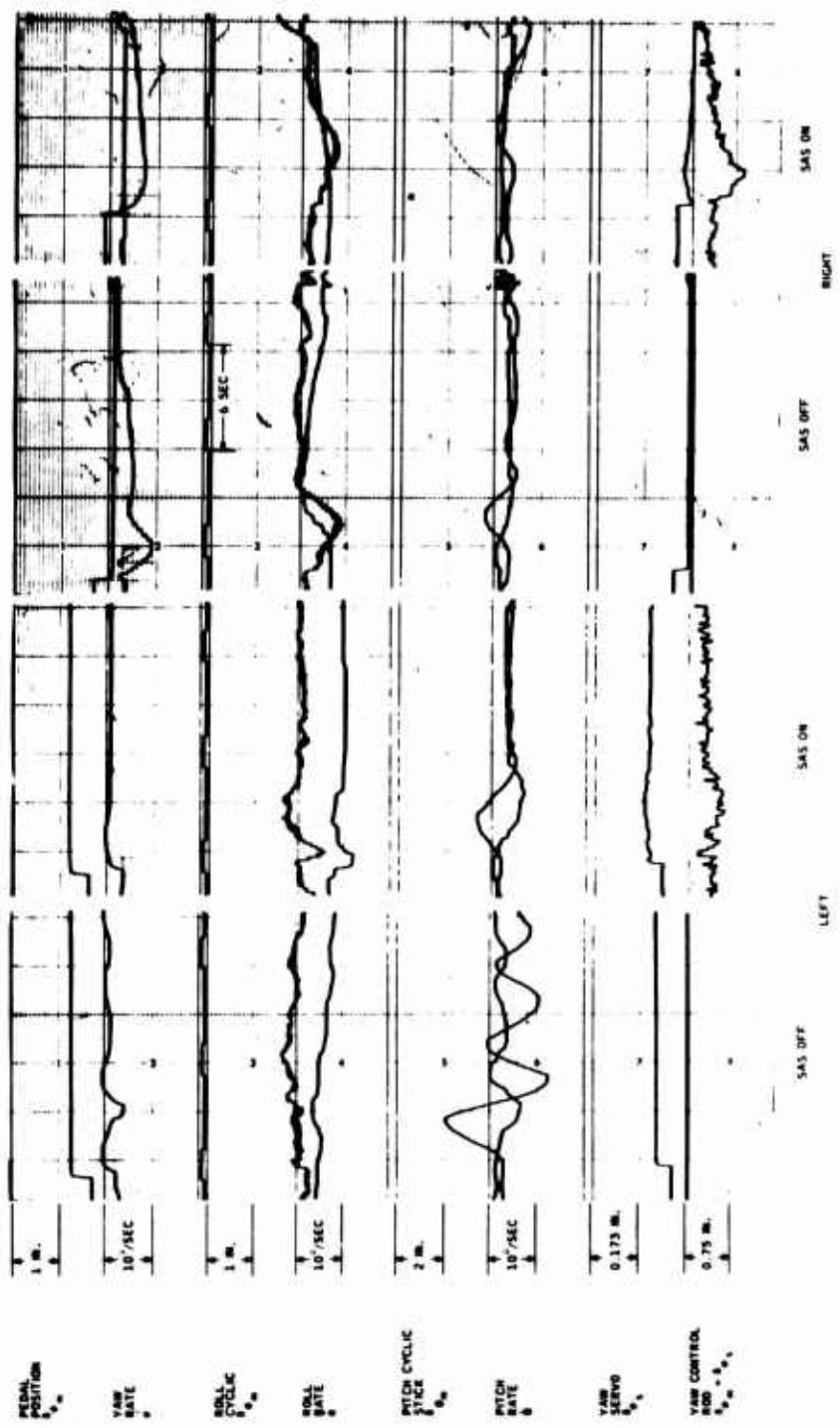

Figure 50. Yaw Steps (Hover, 3,000 Ft) With Straight-Through Yaw Rate Loop.

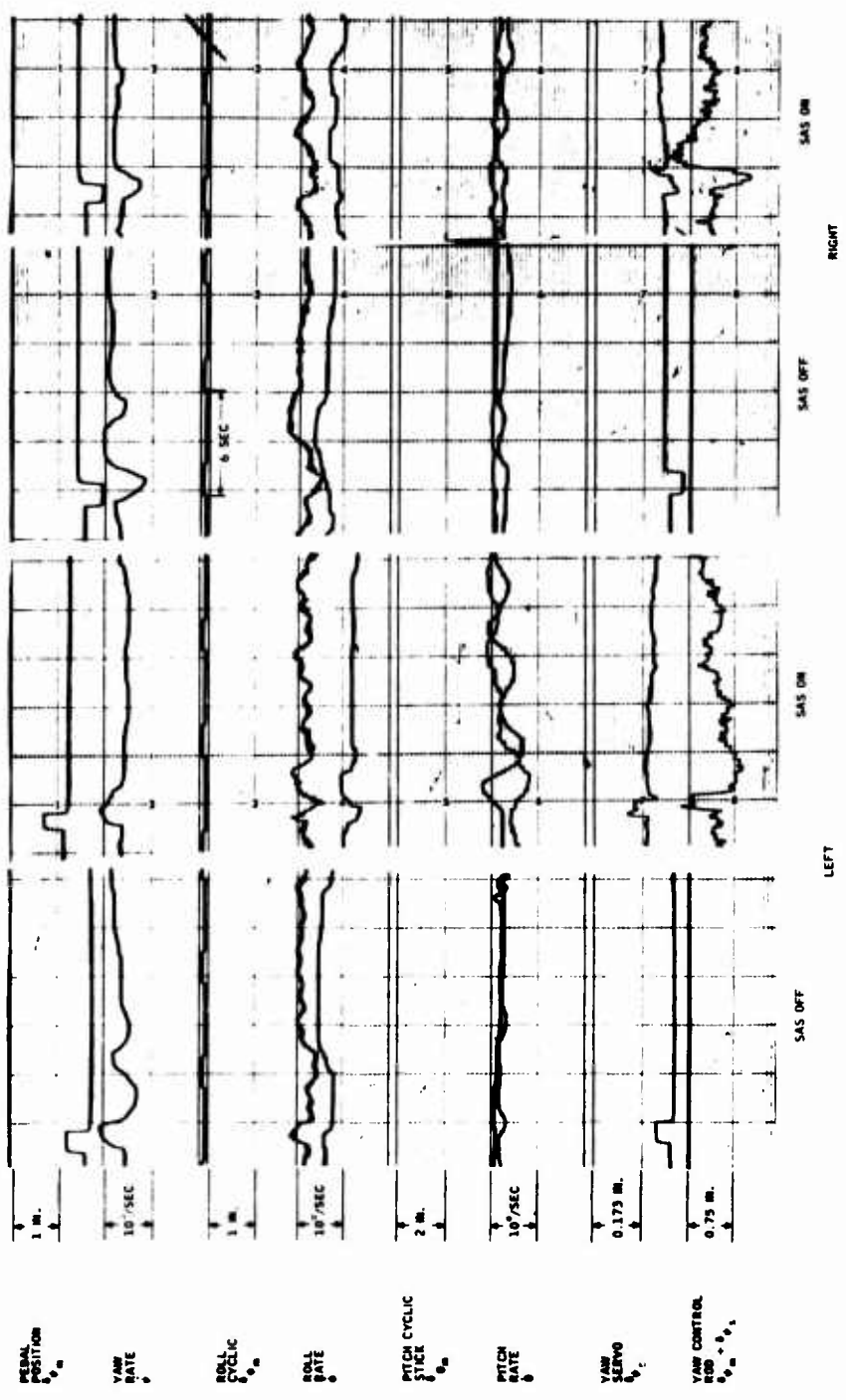

Figure 51. Yaw Pulses (Hover, 3,000 Ft) With Straight-Through Yaw Rate Loop.

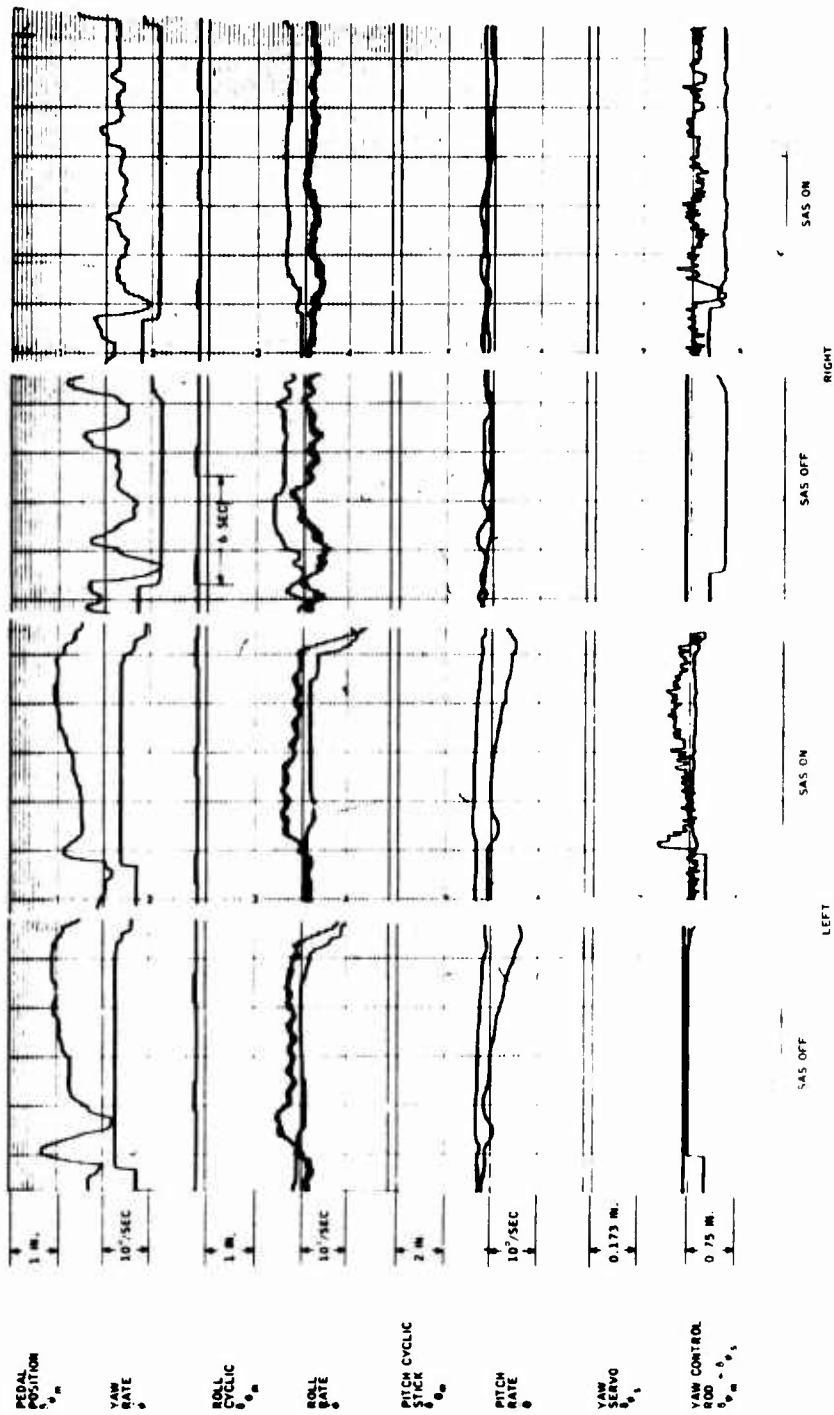

Figure 52. Yaw Steps (60 Kn, 3,000 Ft) With Straight-Through Yaw Rate Loop.

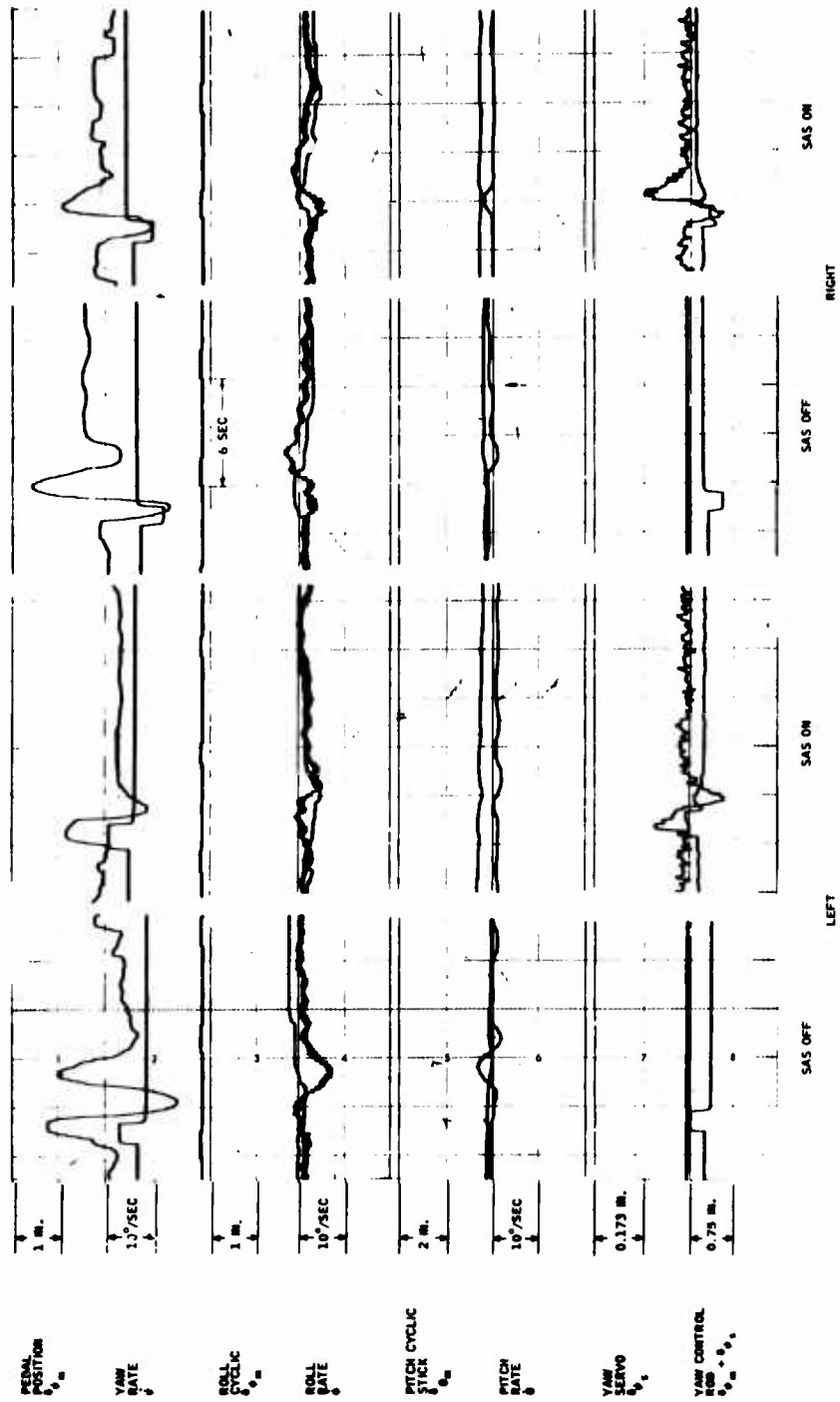

Figure 53. Yaw Pulses (60 Kn, 3,000 Ft) With Straight-Through Yaw Rate Loop.

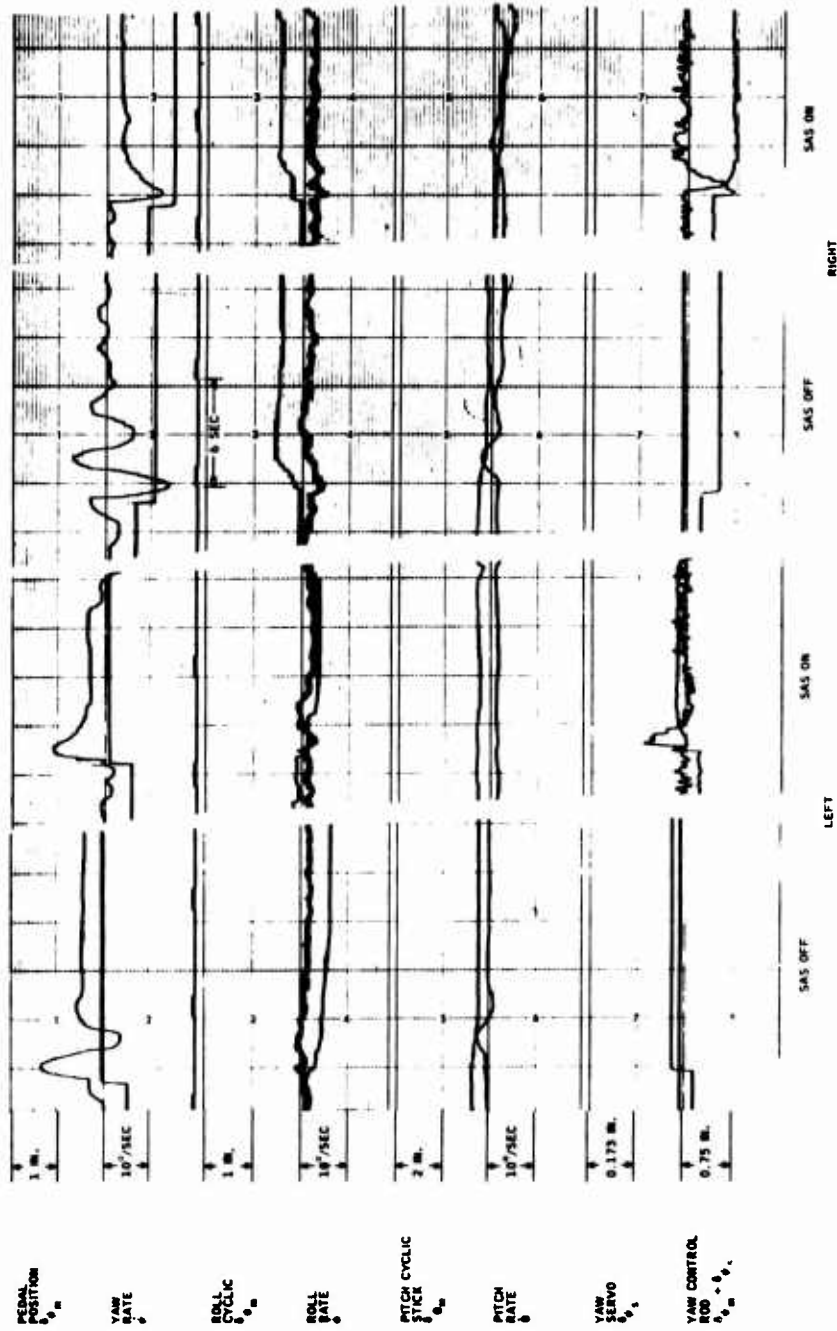

Figure 54. Yaw Steps (60 Kn, 6,000 Ft) With Straight-Through Yaw Rate Loop.

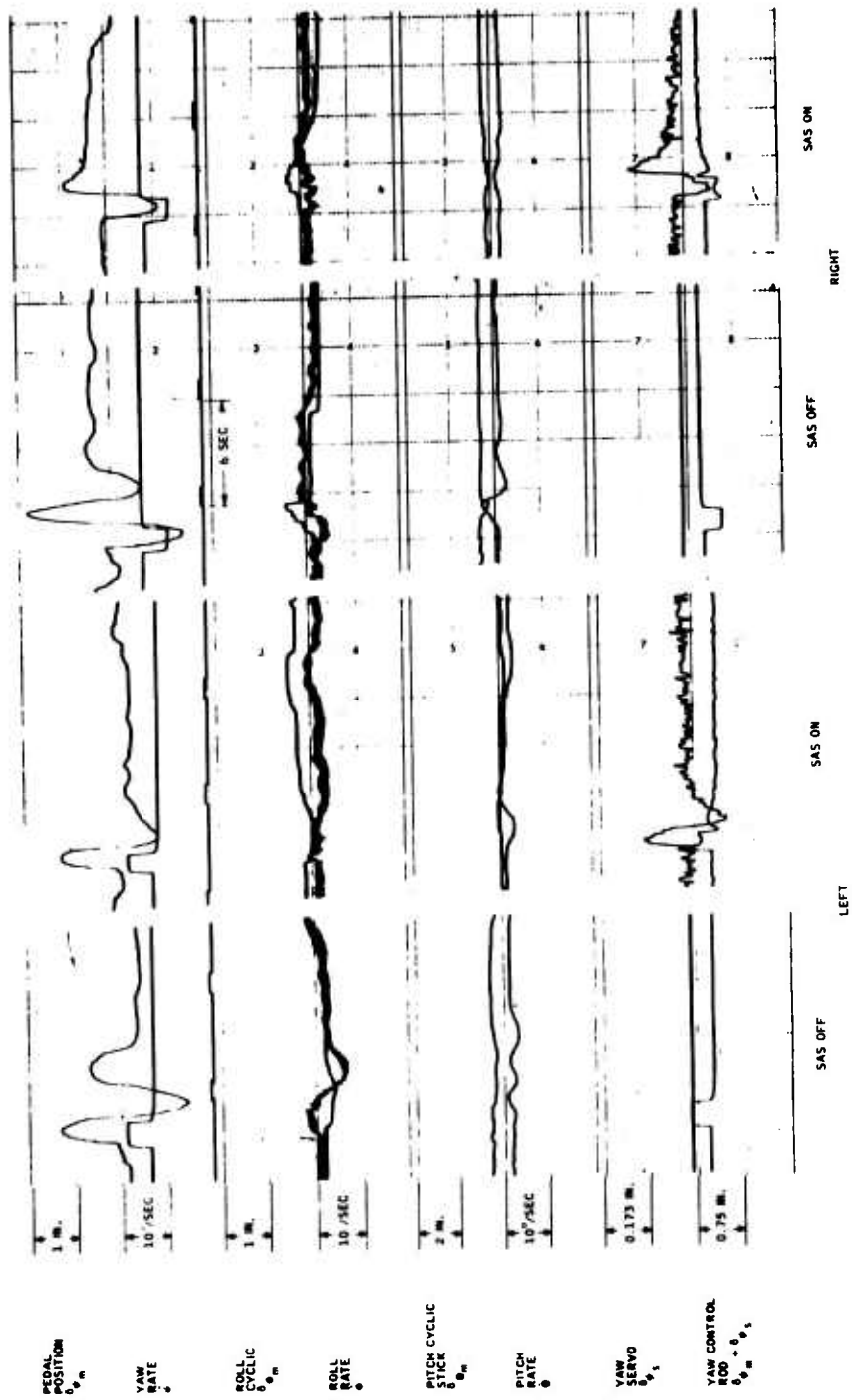

Figure 55. Yaw Pulses (60 Kn, 6,000 Ft) With Straight-Through Yaw Rate Loop.

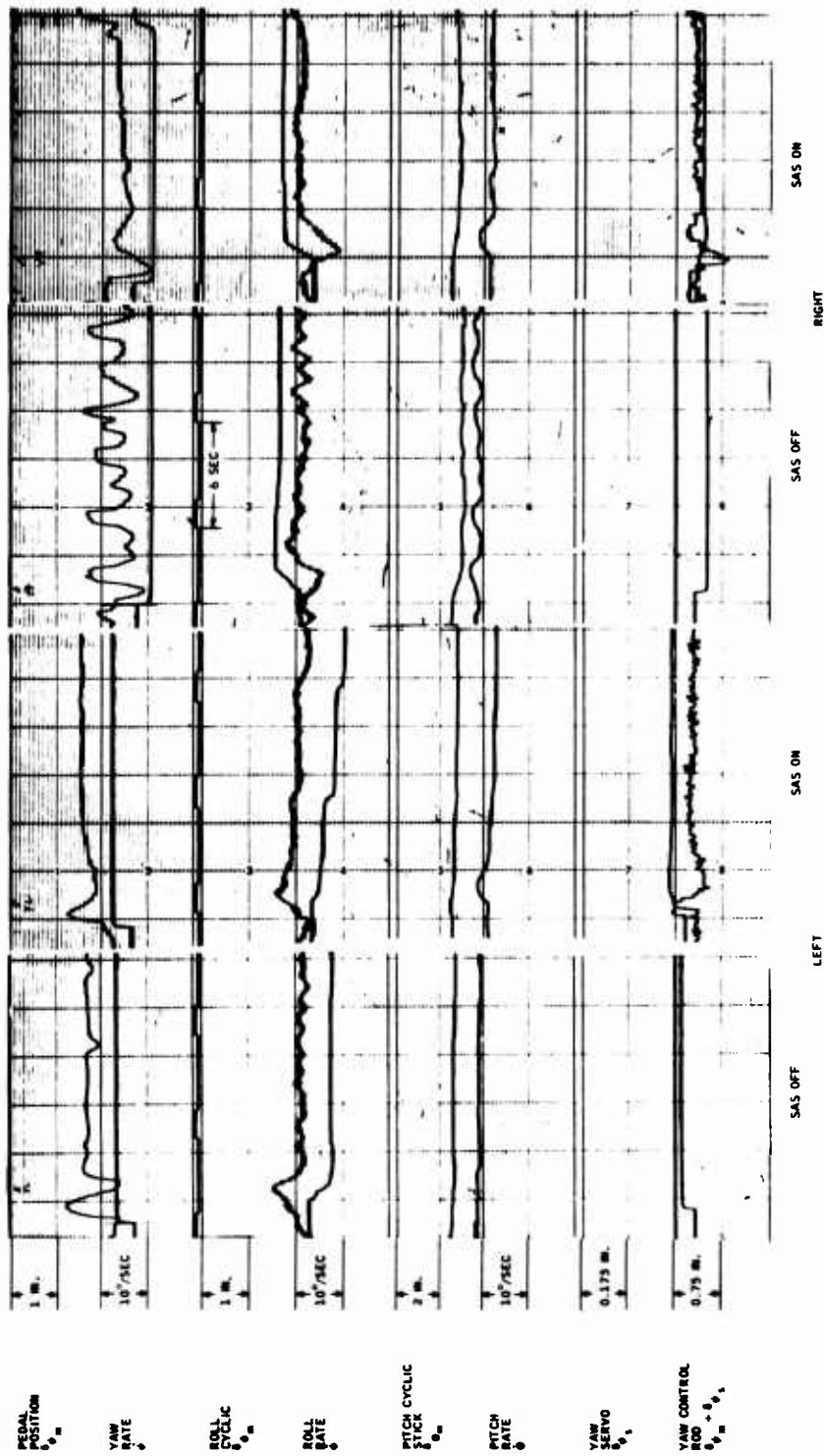

Figure 56. Yaw Steps (90 Kn, 3,000 Ft) With Straight-Through Yaw Rate Loop.

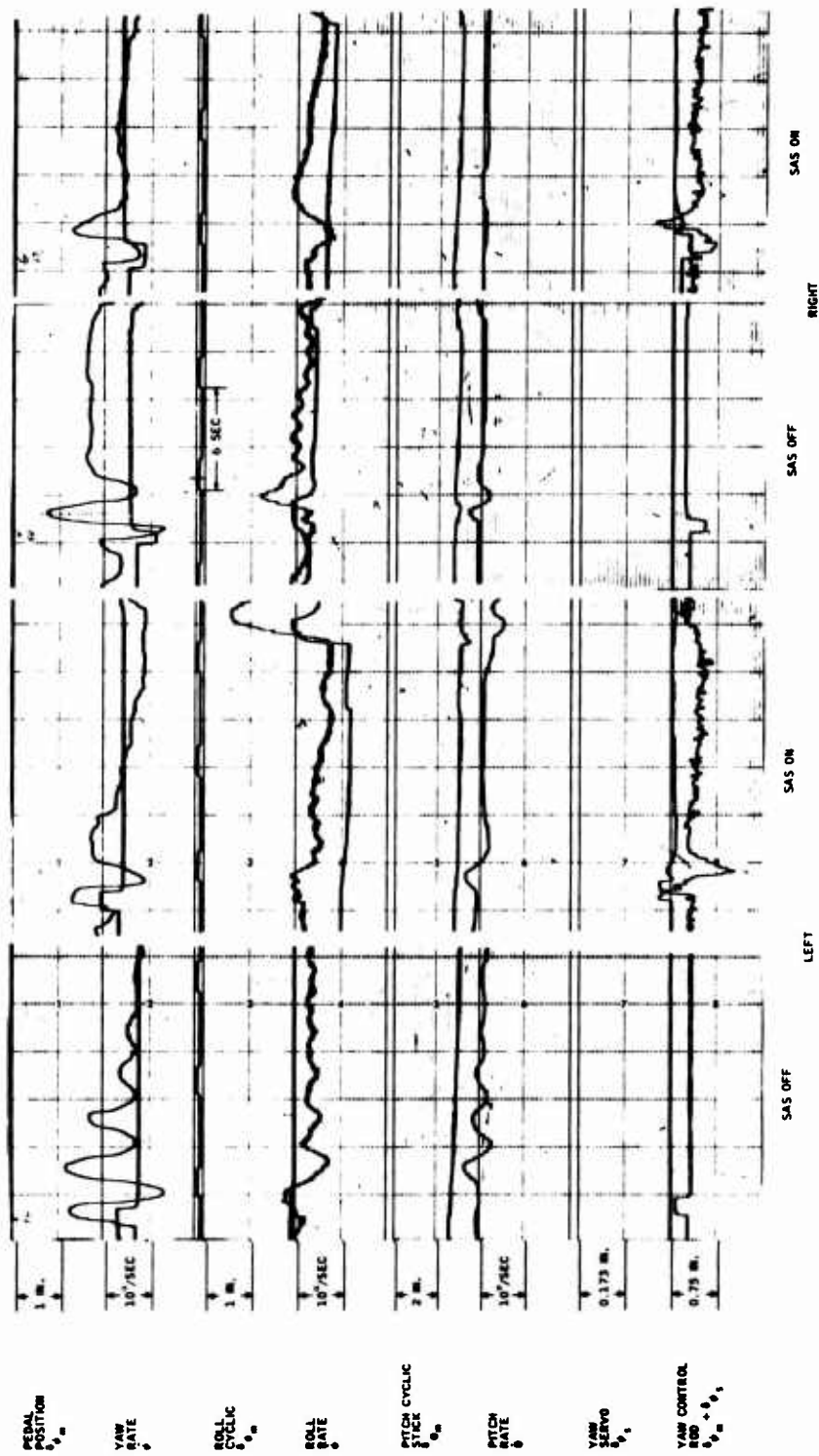

Figure 57. Yaw Pulses (90 Kn, 3,000 Ft) With Straight-Through Yaw Rate Loop.

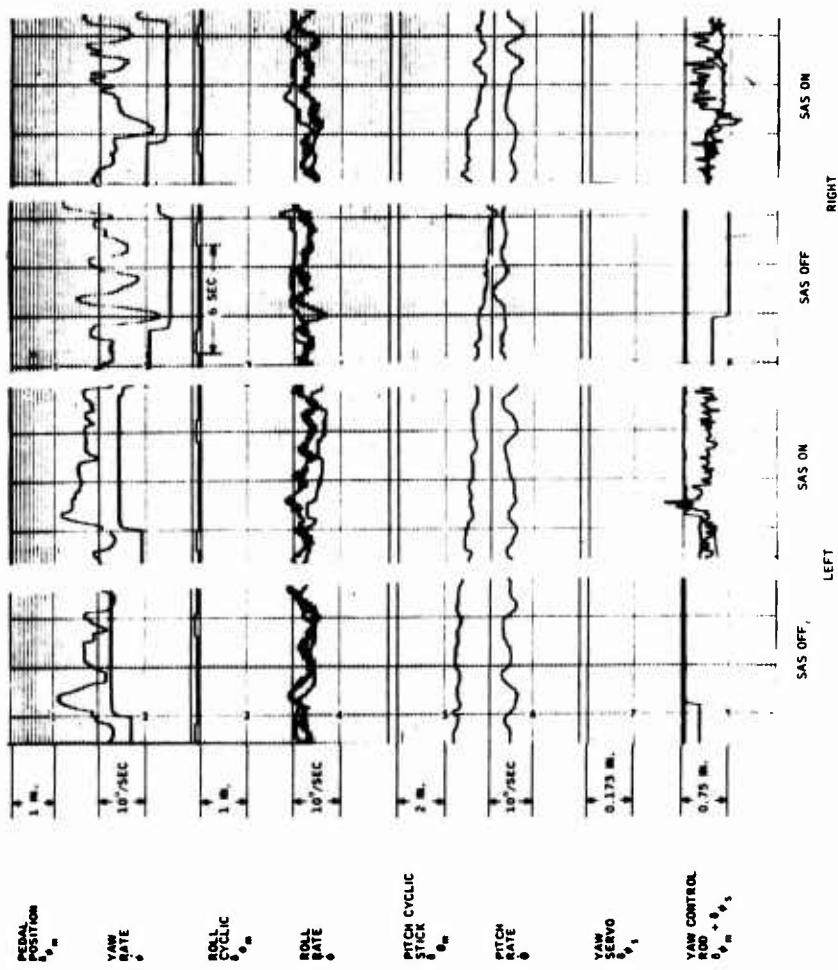

Figure 58. Yaw Steps (90 Kn, 3,000 Ft) With Straight-Through Yaw Rate Loop - Access Doors Off.

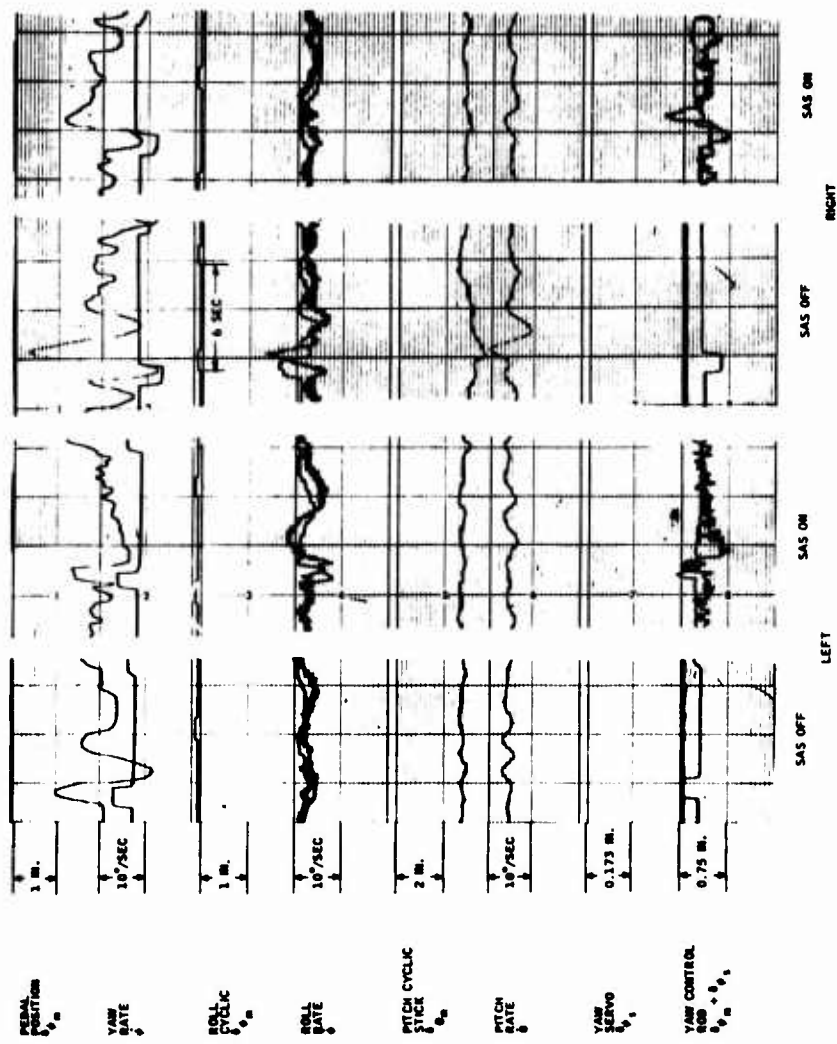

Figure 59. Yaw Pulses (90 Kn, 3,000 Ft) With Straight-Through Yaw Rate Loop - Access Doors Off.

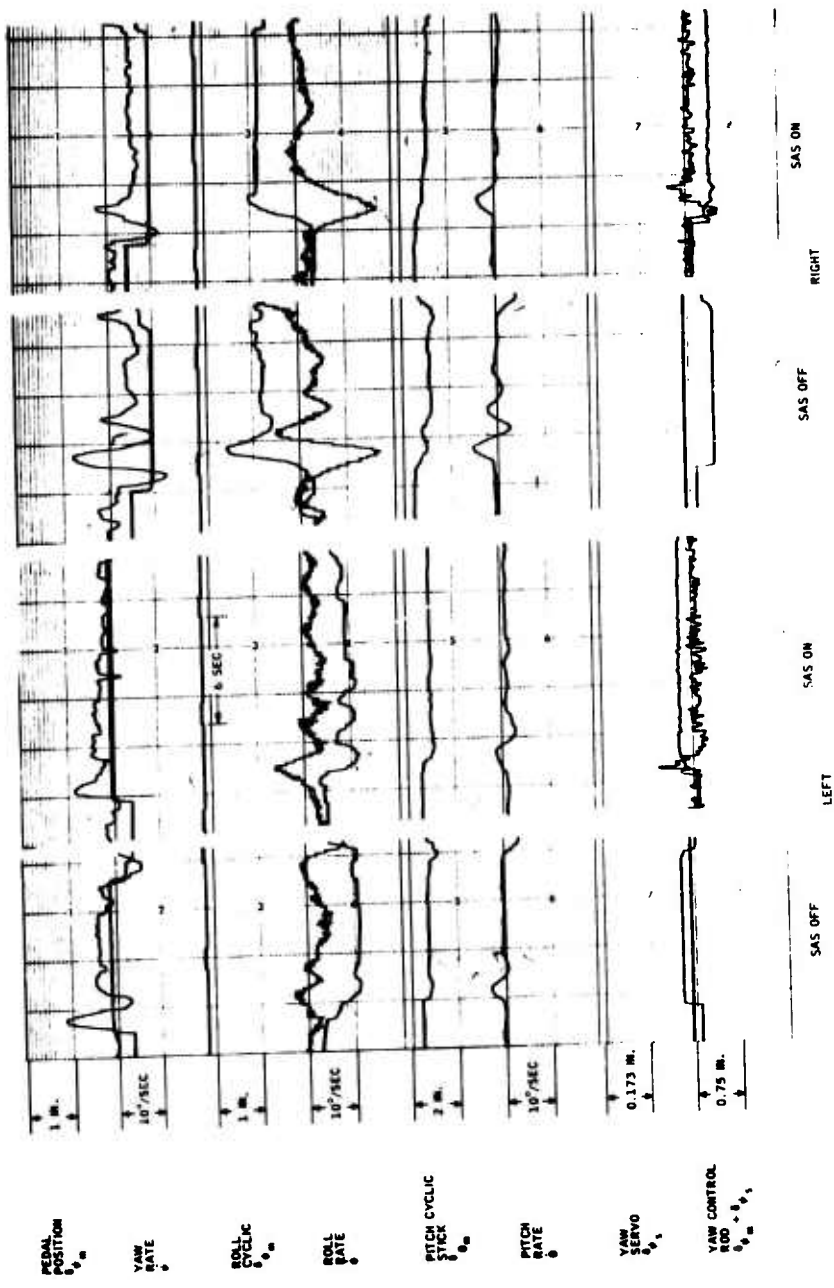

Figure 60. Yaw Steps (110 Kn, 3,000 Ft) With Straight-Through Yaw Rate Loop.

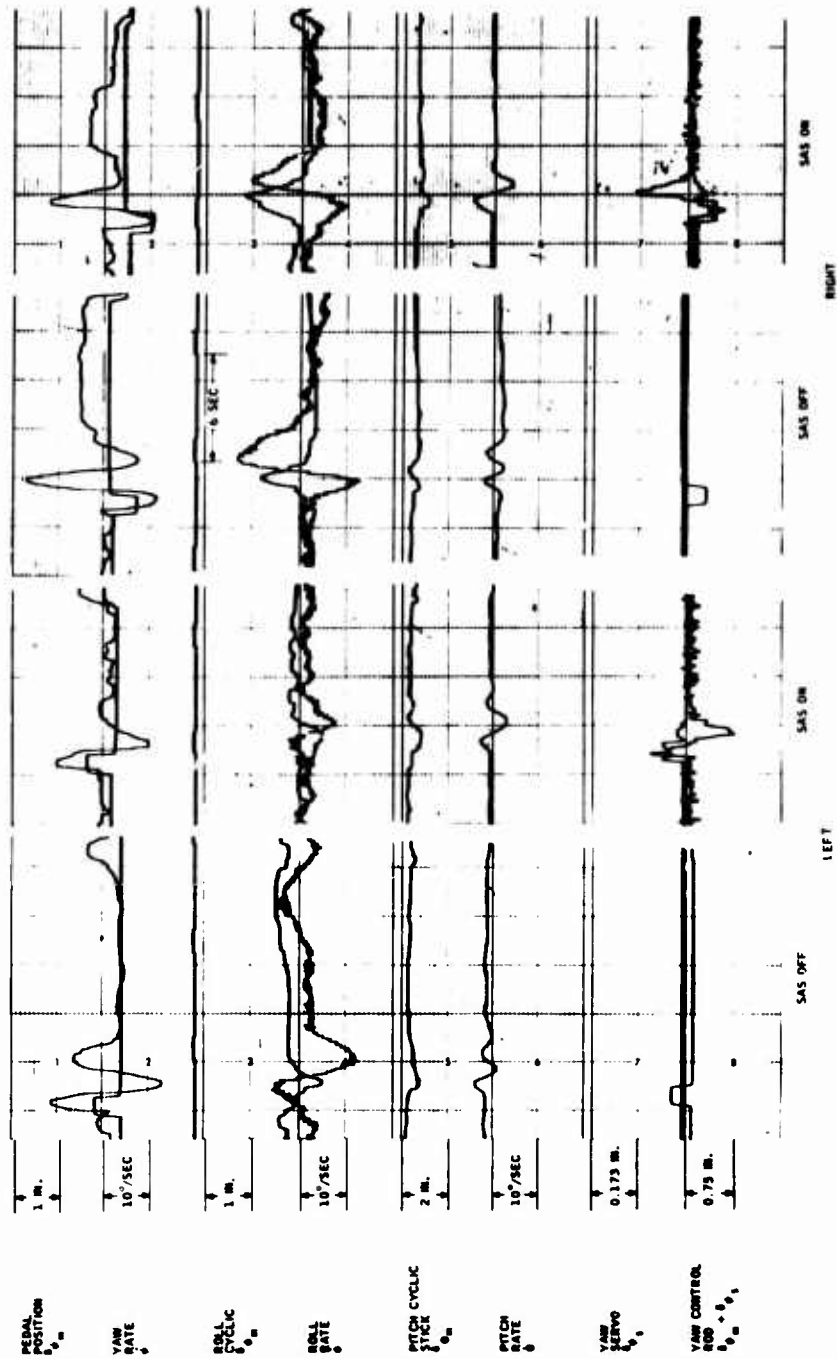

Figure 61. Yaw Pulses (110 Kn, 3,000 Ft) With Straight-Through Yaw Rate Loop.

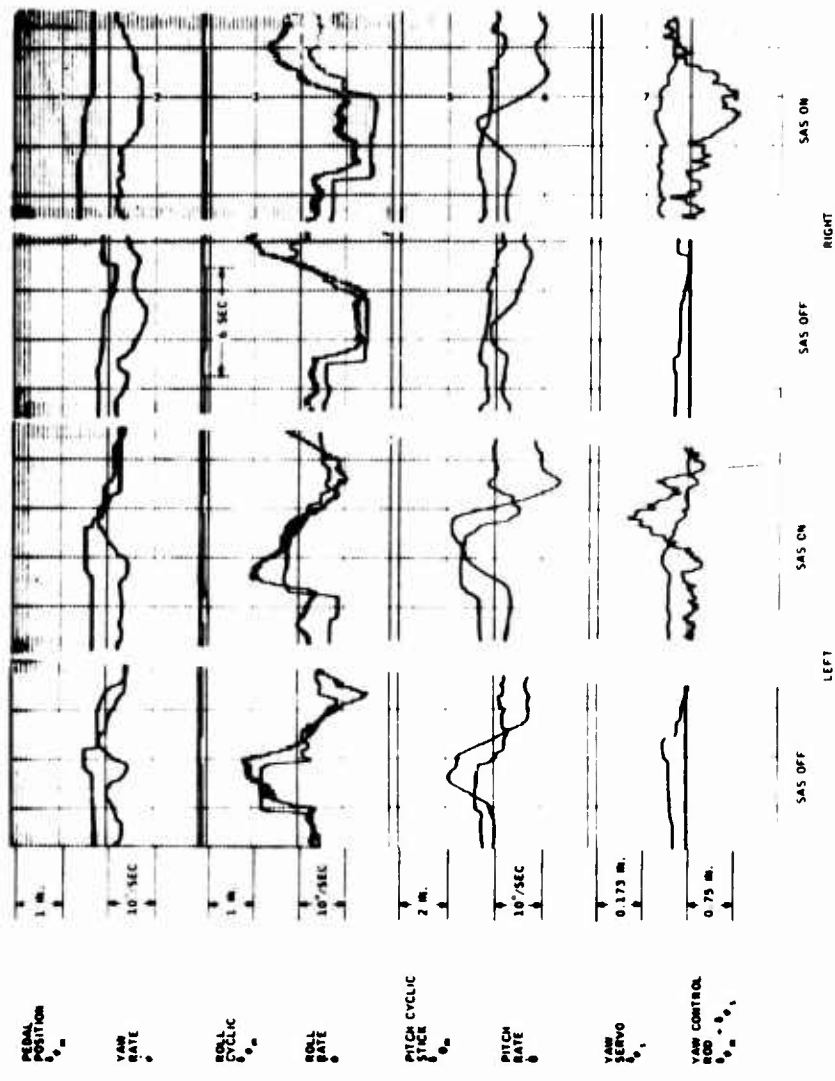

Figure 62. Roll Steps (Hover, 3,000 Ft) With Straight-Through Yaw Rate Loop $\delta_{\phi} = .6 \text{ In.}$

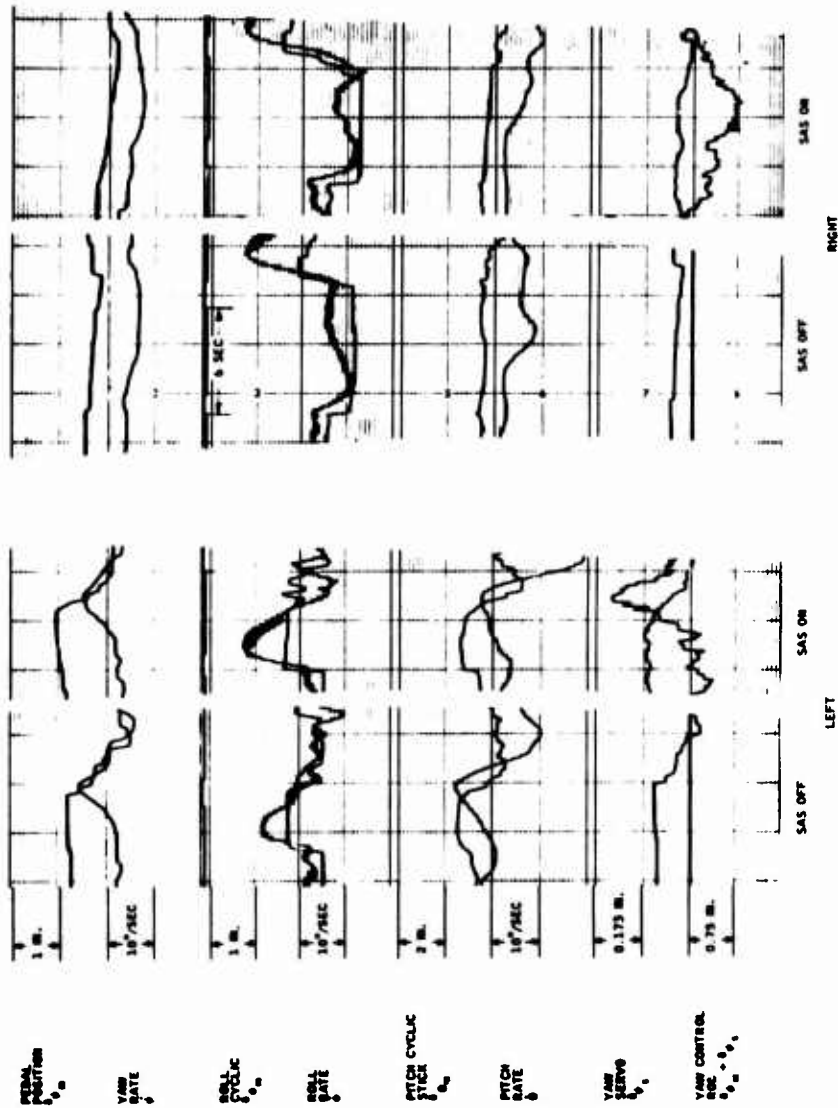

Figure 63. Roll Steps (Hover, 3,000 Ft) With Straight-Through Yaw Rate Loop $\delta_m = .25$ in.

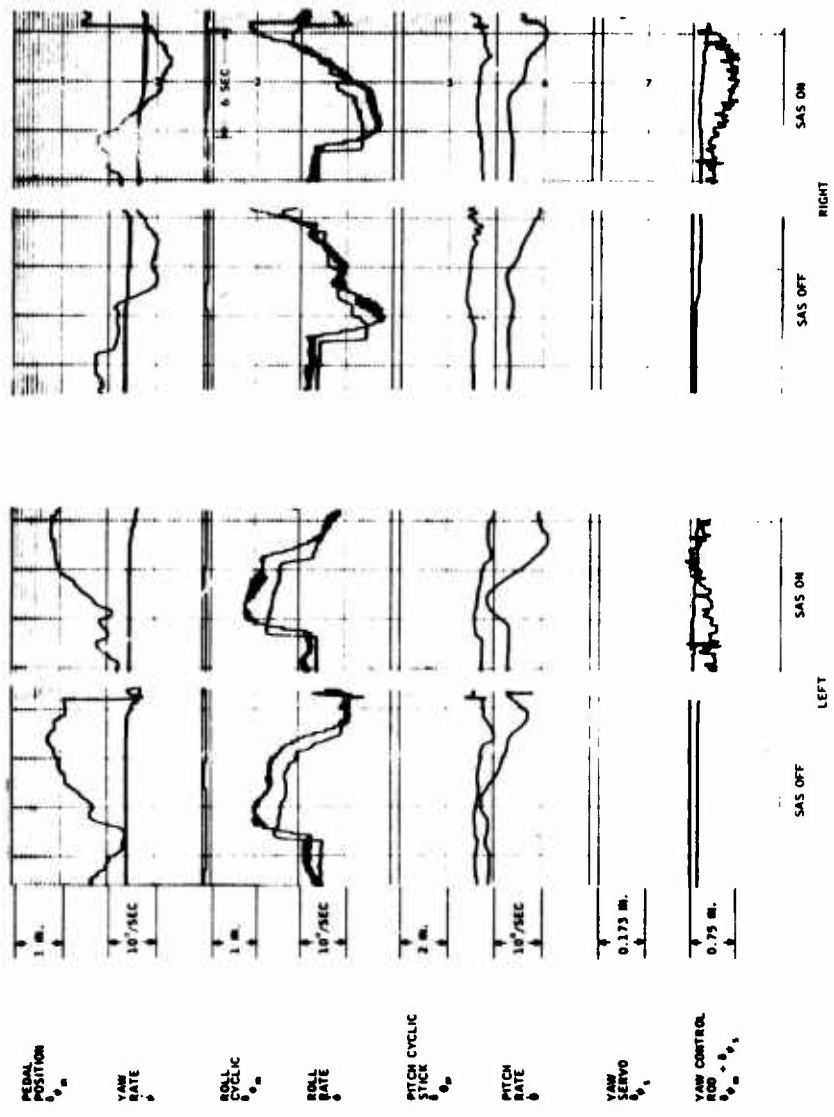

Figure 64. Roll Steps (60 Kn, 3,000 Ft) With Straight-Through Yaw Rate Loop $\delta\phi_m = .6$ in.

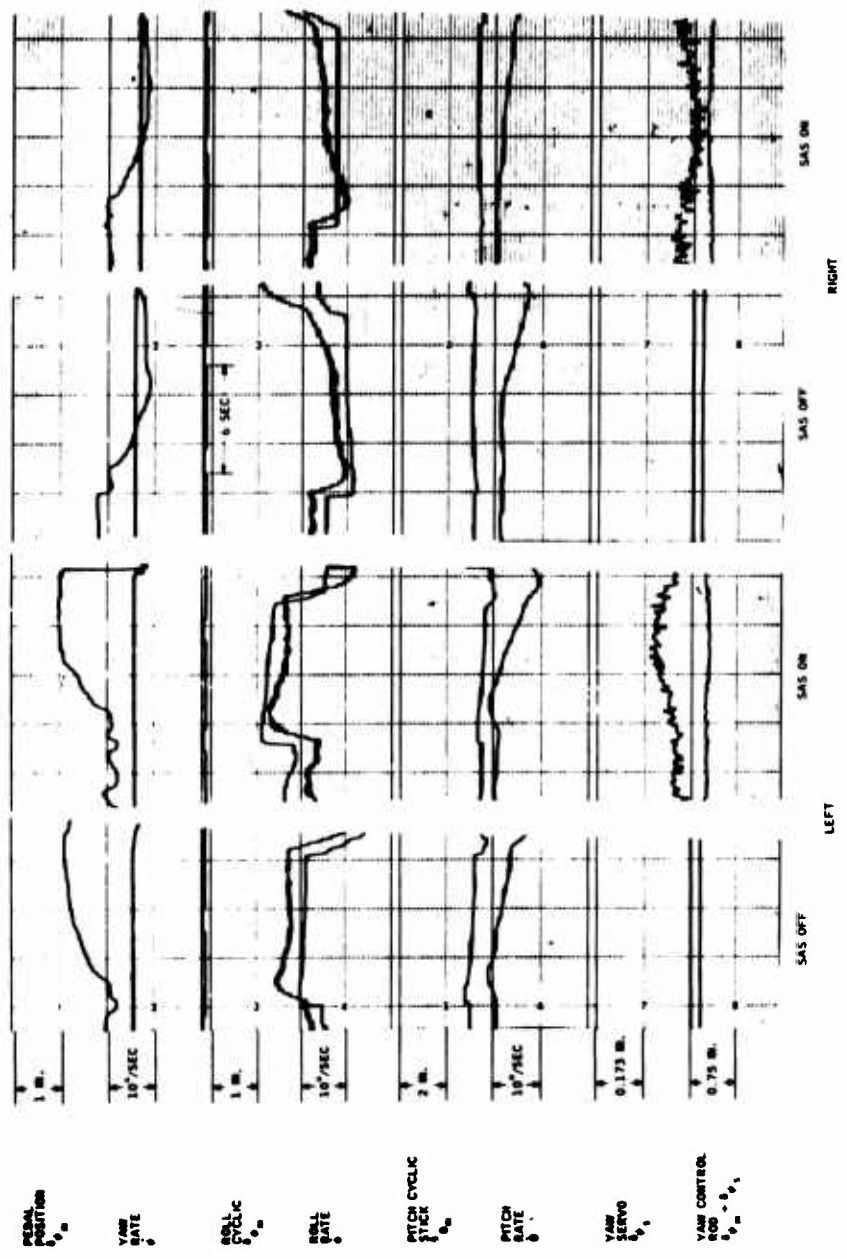

Figure 65. Roll Steps (60 Kn, 3,000 Ft) With Straight-Through Yaw Rate Loop
 $\delta\phi_m = .25 \text{ In.}$

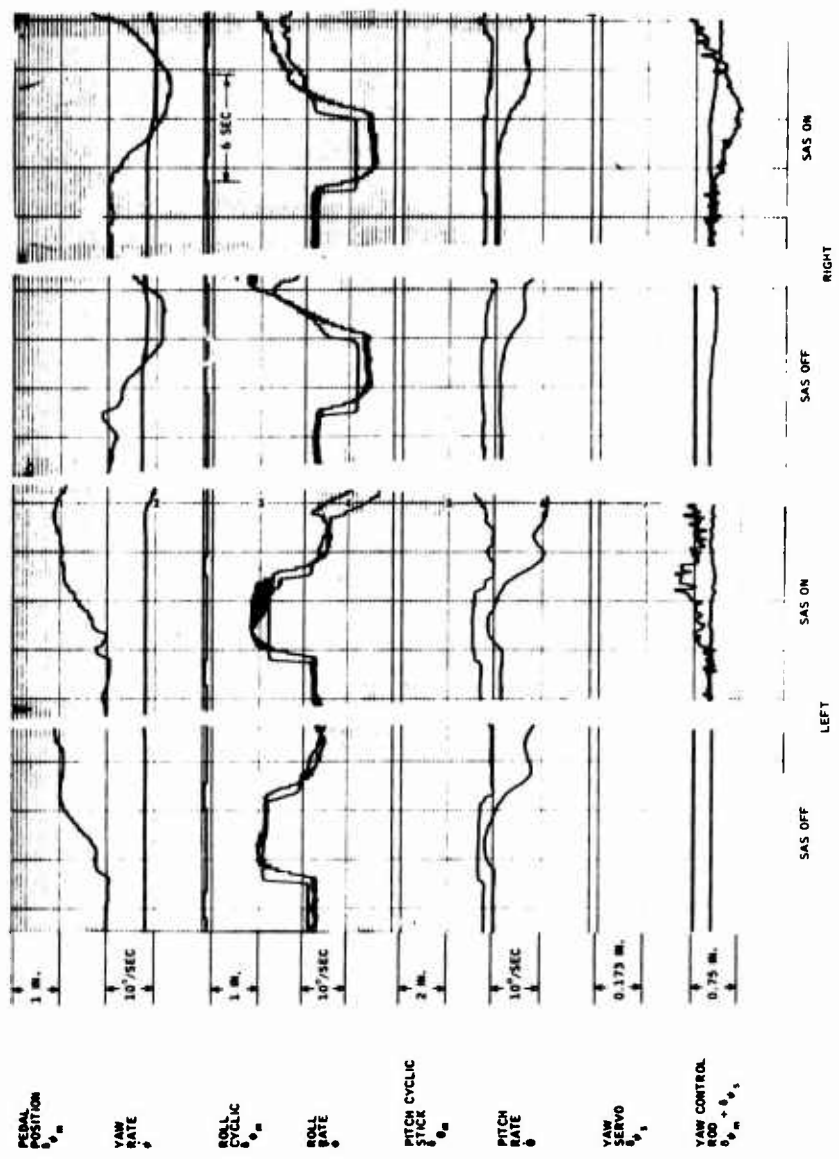

Figure 66. Roll Steps (60 Kn, 6,000 Ft) With Straight-Through Yaw Rate Loop $\delta_{\phi} = .6 \text{ in.}$

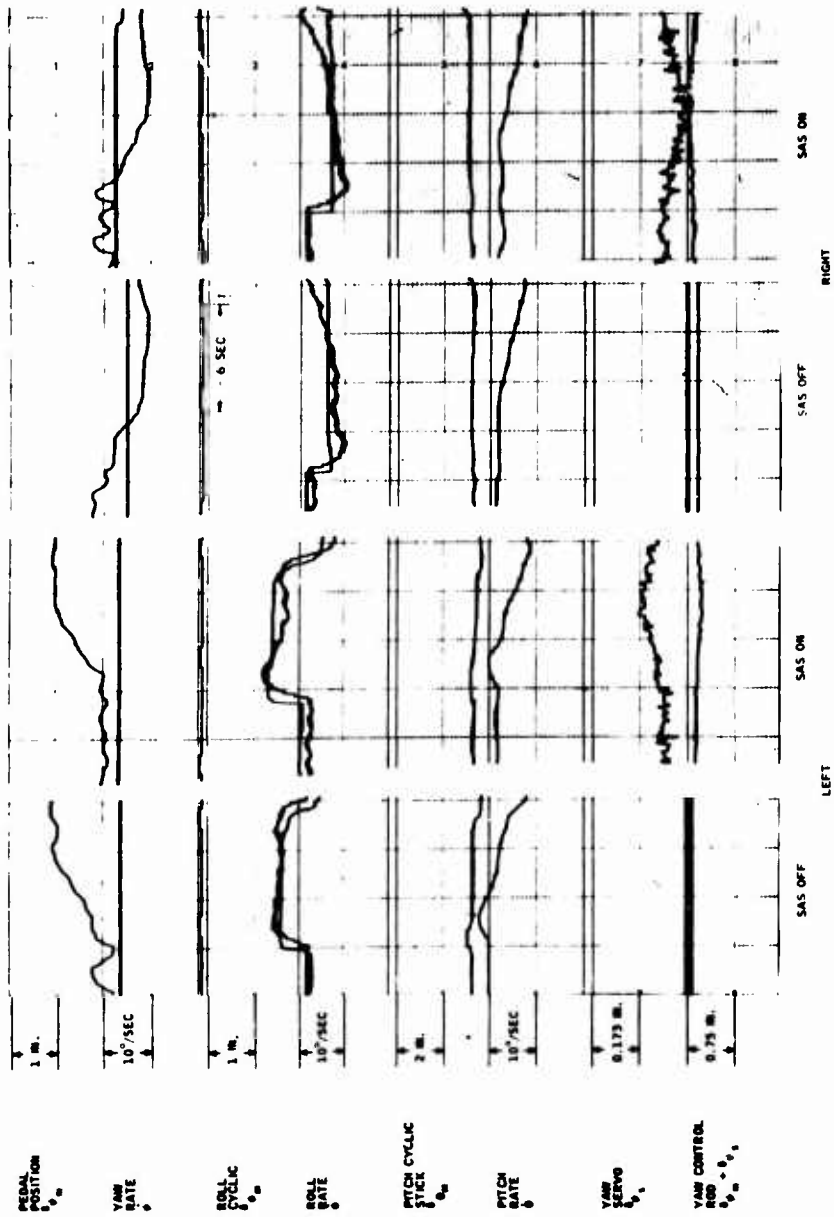

Figure 67. Roll Steps (60 Kn, 6,000 Ft) With Straight-Through Yaw Rate Loop
 $\delta \Phi = .25 \text{ in.}$

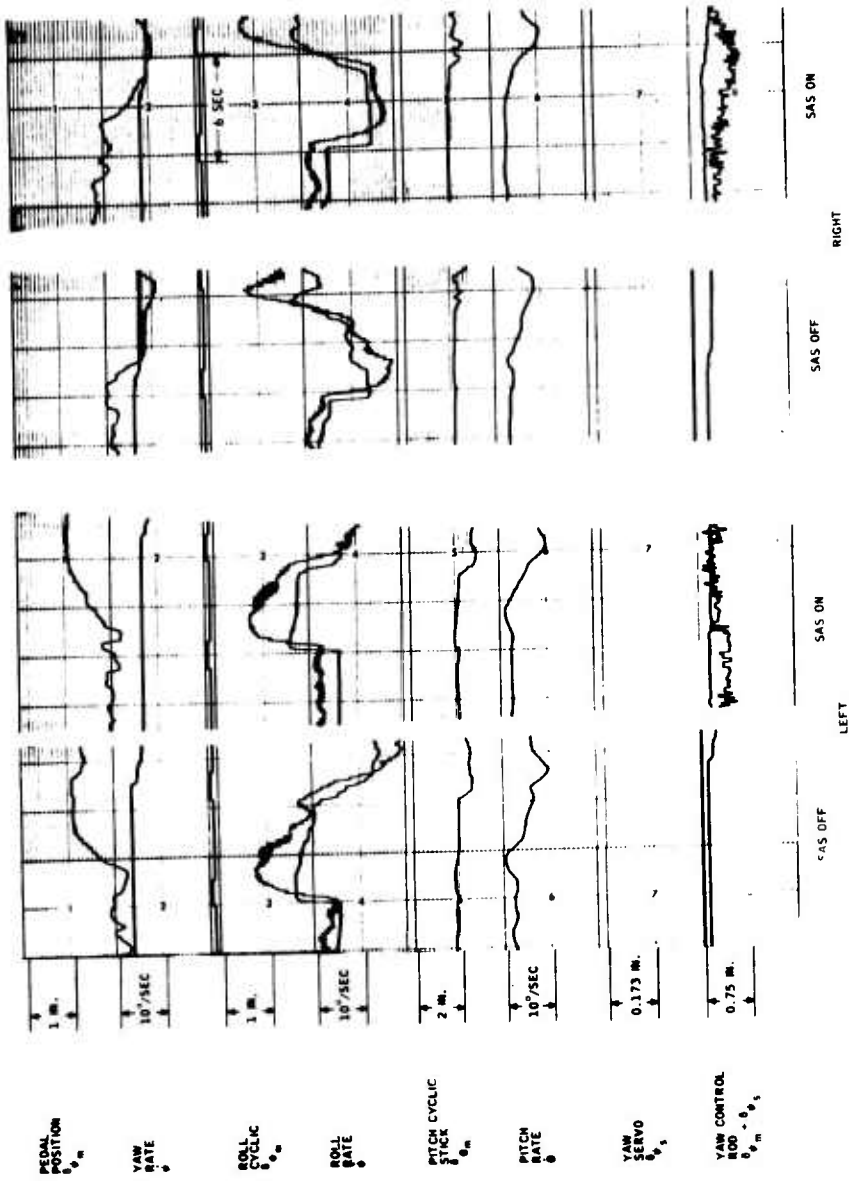

Figure 68. Roll Steps (90 Kn, 3,000 Ft) With Straight-Through Yaw Rate Loop
 $\delta_{\phi} = .6 \text{ in.}$

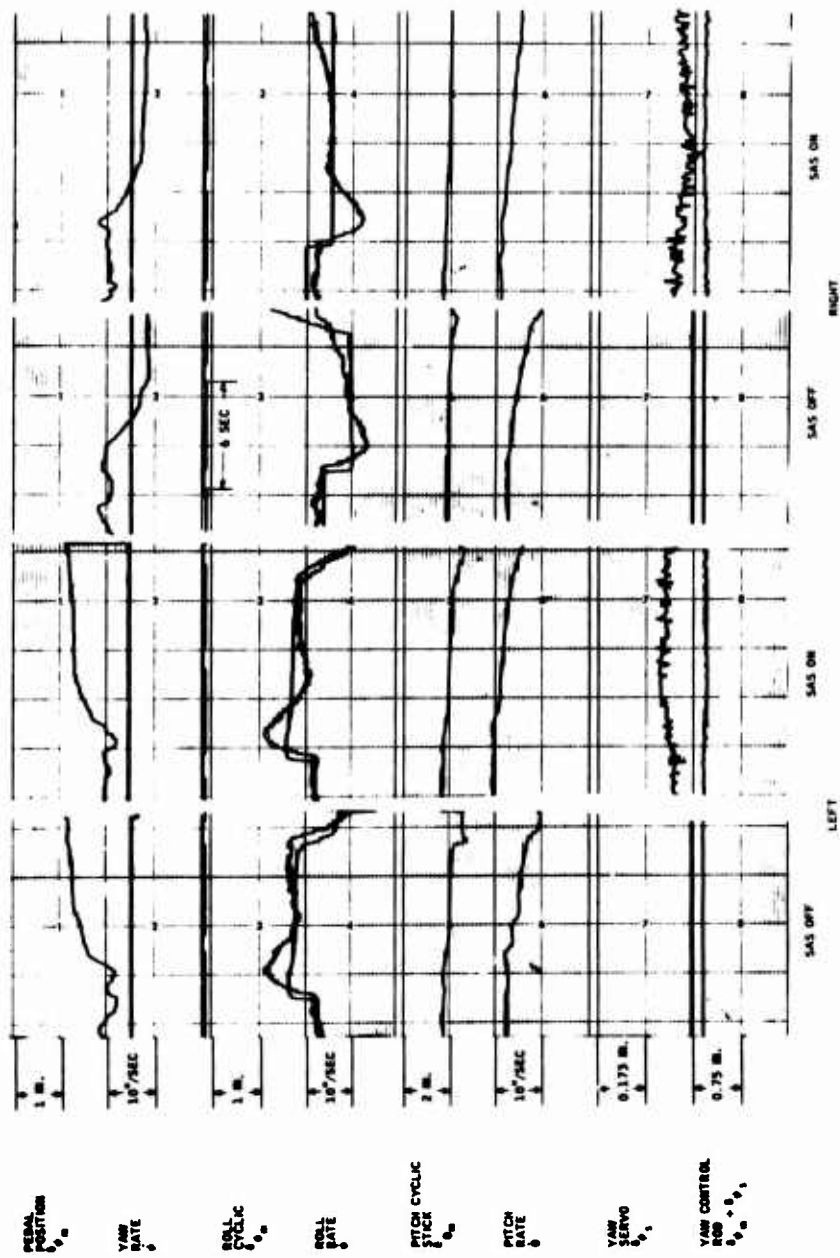

Figure 69. Roll Steps (90 Kn, 3,000 Ft) With Straight-Through Yaw Rate Loop
 $\delta \phi_m = .25 \text{ In.}$

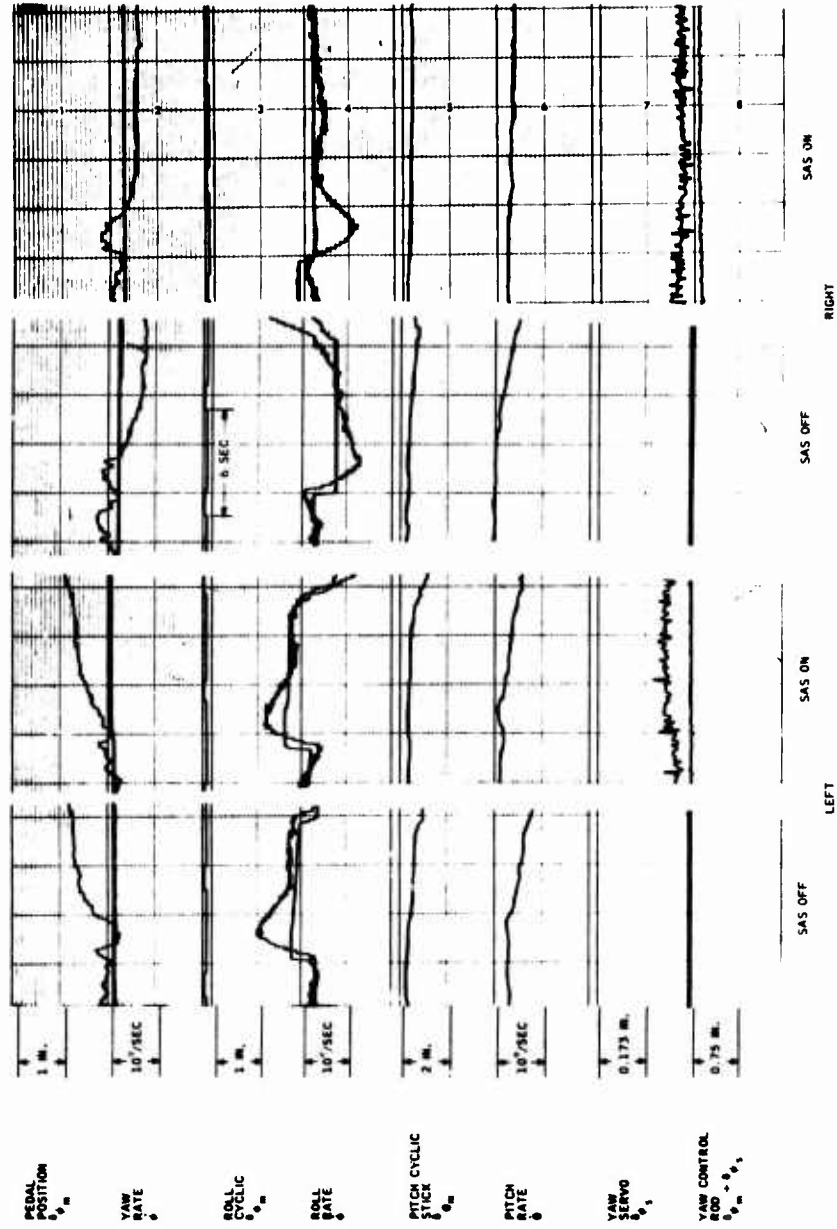

Figure 70. Roll Steps (110 Kn, 3,000 Ft) With Straight-Through Yaw Rate Loop.

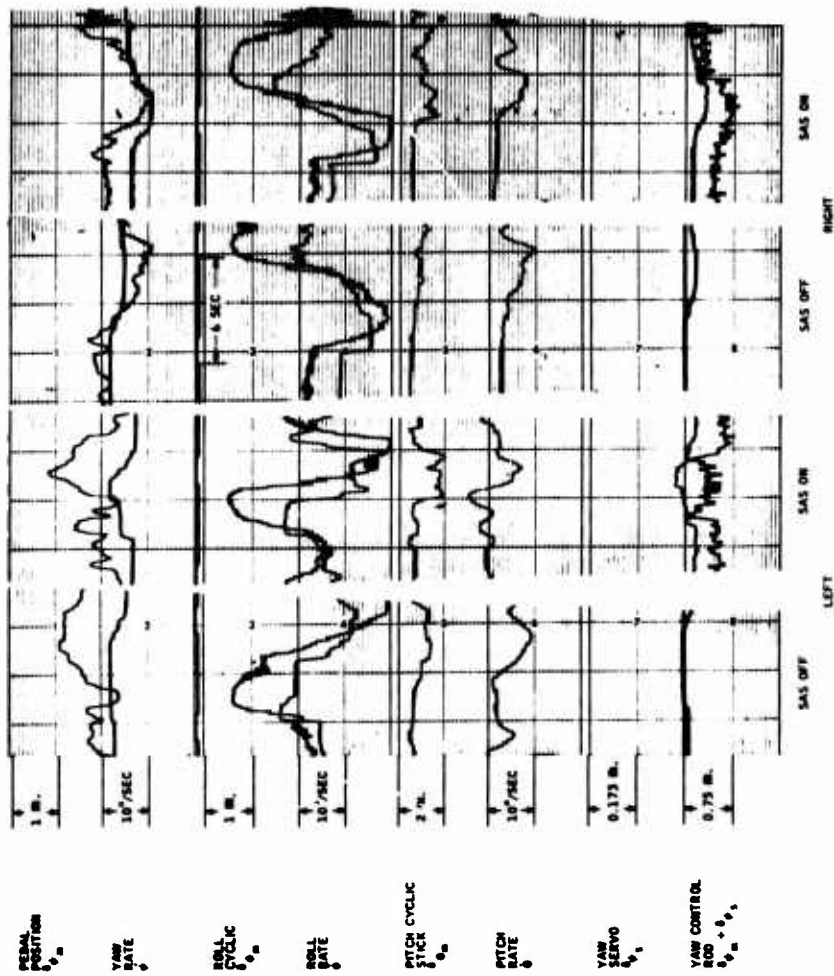

Figure 71. Roll Steps (110 Kn, 6,000 Ft) With Straight-Through Yaw Rate Loop.

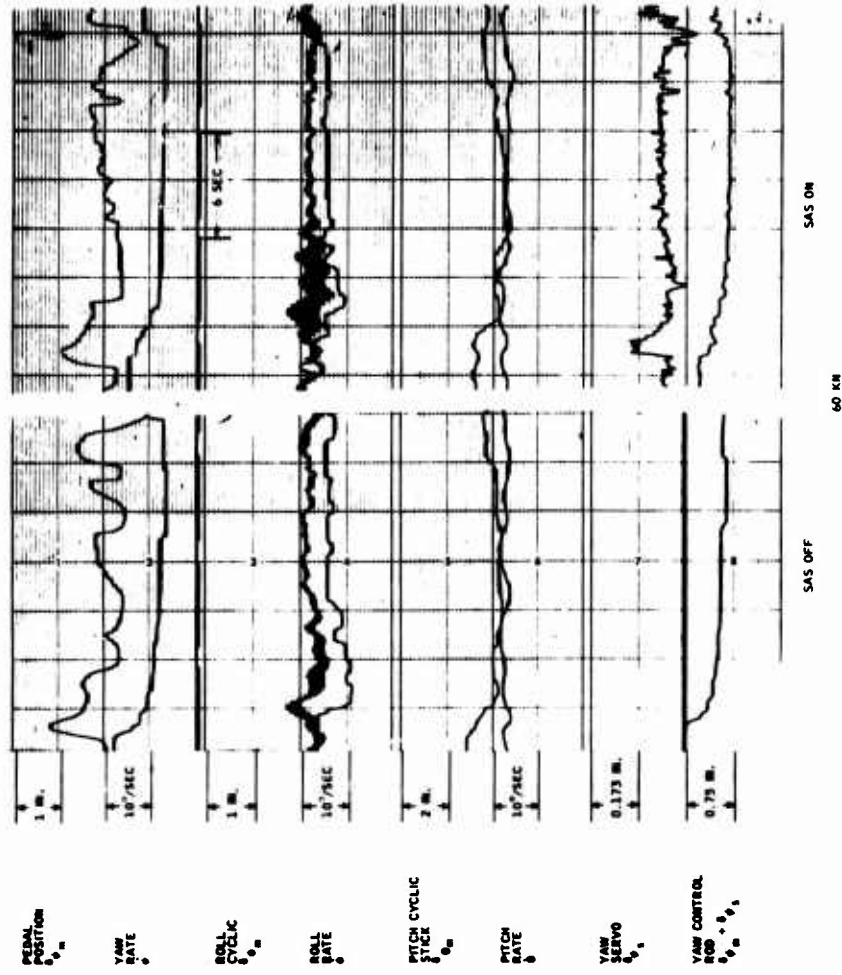

Figure 72. Autorotation (60 Kn) With Straight-Through Yaw Rate Loop.

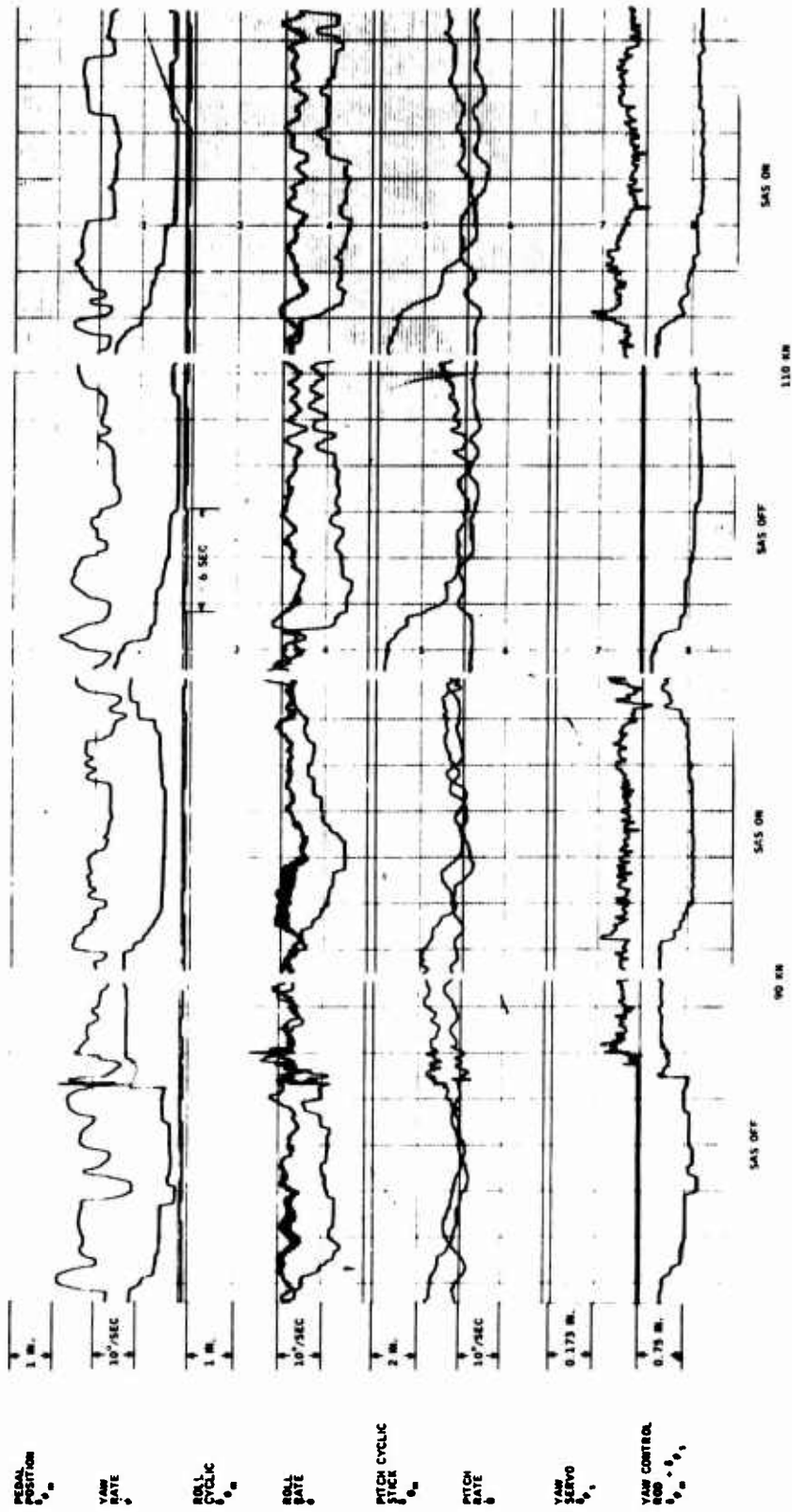

Figure 73. Autorotation (90, 110 Kn) With Straight-Through Yaw Rate Loop.

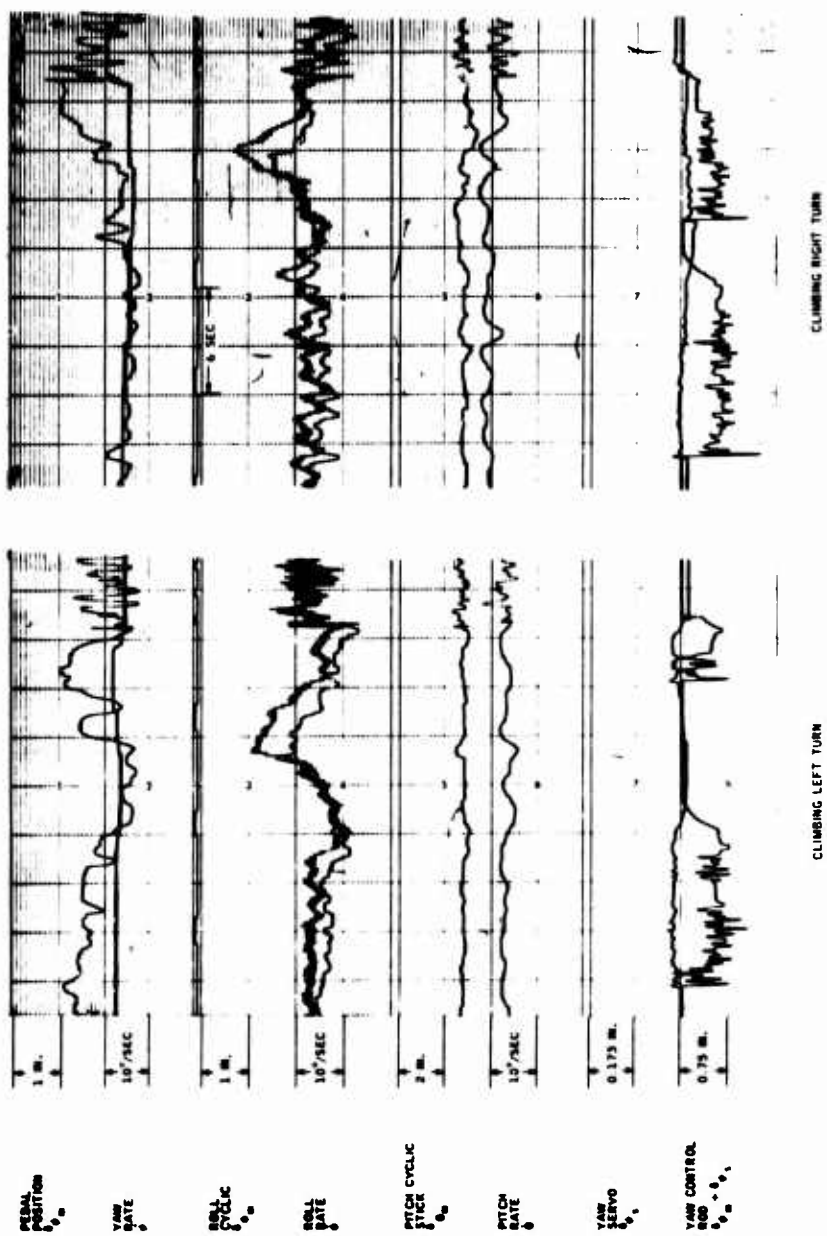

Figure 74. Engage/Disengage Transients With Straight-Through Yaw Rate Loop.

TABLE II. DIRECTIONAL CONTROL POWER					
Altitude (ft)	Actual Displacement (deg) for 1-Inch Step for 1 sec				MIL-H-8501A Required Displacement (deg)
	High-Passed Yaw Rate		High-Passed Plus Straight-Through Yaw Rate		
	Without SAS	With SAS	Without SAS	With SAS	
5	-	-	19.5	14.3	7.27 to 50.0 ↓
			11.9	23.4	
75	10.5	9.6	-	-	
1200	8.4	16.1	-	-	
3000	30.9	19.9	9.8	10.3	
			10.2	19.5	

ANGULAR VELOCITY BUILDUP

The angular velocity buildup requirement, paragraph 3.3.16 of MIL-H-8501A, states that angular acceleration shall be in the proper direction within .2 second after control displacement. Results are summarized in Table III. Reduction of these data is difficult because of the recorder time scale chosen (1.45 in. = 6 sec) and the width of the recorder traces (up to .08 sec). It appears that the aircraft is marginally out of specification limits with either SAS or with no SAS. Again, because of yaw rate feedback, one would expect a slight increase in angular velocity buildup time, but the data scaling was such that it would not be perceptible.

DAMPING

Damping requirements are stated in paragraph 3.6.1.2 (a) of MIL-H-8501A as ". . . any oscillation having a period of less than 5 seconds shall damp to one-half amplitude in not more than one cycle. . . ." At all flight conditions other than hover the periods of oscillation are less than 5 seconds, and for these conditions a damping ratio of .215 will suffice.

At forward flight conditions the yaw rate response with the SAS off is quite oscillatory, and damping ratios are calculated using the transient subsidence ratios. With the SAS on the yaw response is well damped and damping ratios are estimated by comparing the response to that of second-order systems of known damping ratios.

Results are summarized, for forward flight, in Table IV. Both SAS configurations increase yaw damping to the point where the .215 requirement is easily satisfied. The average damping ratio for the listed flight conditions is only slightly greater for the high-passed plus straight-through yaw rate configuration - .55 as opposed to .52. Damping of the free aircraft, however, was poorer during the October-December 1973 flight test than during those completed in October 1972, although the same aircraft was used for both. If one looks at the average increment of damping added by the SAS, over and above that of the free aircraft, it is seen that the contribution of the high-passed plus straight-through yaw rate configuration is considerably greater than the high-passed yaw rate configuration - .4 as opposed to .25.

The differences in free aircraft damping noted in flight test of the two systems are ascribed to:

TABLE III. ANGULAR VELOCITY BUILDUP TIME

IAS (kn)	Altitude (ft)	Actual Times (sec)				MIL-H- 8501A Required Time (sec)
		High-Passed Yaw Rate		High-Passed Plus Straight-Through Yaw Rate		
		SAS Off	SAS On	SAS Off	SAS On	
0	5	-	-	.29	.33	.2 max ↓
				.37	.13	
0	75	.09	.27	-	-	
0	1200	.25	.22	-	-	
0	3000	.27	.27	.33	.33	
				.29	.33	
60	3000	.27	.2	.34	.17	
				.28	.29	
60	6000	.29	.27	.33	.29	
				.31	.28	
65	4000	.29	.27	-	-	
90	3000	.24	.22	.33	.29	
				.31	.29	
90	4000	.25	.29	-	-	
110	3000	.24	.29	.26	.29	
				.27	.29	
112	4000	.25	.22	-	-	

TABLE IV. YAW DAMPING IN FORWARD FLIGHT

Indicated Airspeed (kn)	Altitude (ft)	Access Doors	Actual Data												MIL-H-8501A Required ζ	
			High-Passed Yaw Rate						High-Passed Plus Straight-Through Yaw Rate							
			SAS Off			SAS On			SAS Off			SAS On				
			T(sec)	w (rad/sec)	ζ	T(sec)	w (rad/sec)	ζ	T(sec)	w (rad/sec)	ζ	T(sec)	w (rad/sec)	ζ		
60	3,000	Off	3.11	2.02	.35	-	-	.58	-	-	-	-	-	-	-	.215
60	3,000	On	-	-	-	-	-	-	3.39	1.85	.16	-	-	-	-	.34
60	3,000	On	-	-	-	-	-	-	3.8	1.65	.12	-	-	-	-	.6
60	6,000	On	3.3	1.9	.26	2.61	2.4	.8	3.45	1.82	.24	-	-	-	-	.7
60	6,000	On	-	-	-	-	-	-	4.1	1.53	.1	-	-	-	-	.5
65	4,000	On	3.3	1.9	.25	3.07	2.05	.31	-	-	-	-	-	-	-	-
90	3,000	Off	2.58	2.44	.39	-	-	.7	3.29	1.91	.1	-	-	-	-	.6
90	3,000	Off	-	-	-	-	-	-	3.0	2.09	.22	-	-	-	-	.6
90	3,000	On	-	-	-	-	-	-	2.78	2.26	.18	-	-	-	-	.5
90	3,000	On	-	-	-	-	-	-	2.98	2.11	.11	-	-	-	-	.6
90	4,000	On	2.57	2.48	.28	3.2	1.96	.47	-	-	-	-	-	-	-	-
110	3,000	On	2.39	2.63	.185	2.6	2.41	.42	2.25	2.79	.13	-	-	-	-	.65
110	3,000	On	-	-	-	-	-	-	3.31	1.9	.1	-	-	-	-	.45
112	4,000	On	2.4	2.62	.19	2.67	2.35	.35	-	-	-	-	-	-	-	-

- Lack of repeatability of data. Similar test inputs on the same test flight produce somewhat dissimilar results.
- Reduction of damping ratios and natural frequencies from flight test recordings is, at best, imprecise.
- Increased effort during the October-December 1973 flight tests to keep the roll cyclic stick fixed while inserting test inputs at the pedal, thus reducing interaxis coupling.

Most of the data was taken with the crew access doors in place, but for one flight condition, 90 kn at 3,000 ft, the test was repeated with access doors removed. AMRDL wanted to determine if removal of the doors had any effect on yaw damping. Other test conditions remained unchanged.

At forward flight speeds, some increase in damping with removal of the access doors was expected. Although some changes in damping were evident, damping did not consistently increase nor decrease. Therefore, it cannot be concluded that the changes resulted directly from removing the doors.

At hover the yaw rate response to a step input of pedal differs from that at forward flight. Instead of an exponentially decaying oscillatory transient, yaw rate increases monotonically. Paragraph 3.3.7 of MIL-H-8501A states that "the maximum rate of yaw per inch of sudden pedal displacement from trim while hovering shall not be so high as to cause a tendency for the pilot to overcontrol unintentionally." During flight tests of the high-passed yaw rate configuration in October 1972, yaw rates were very high. In most instances the recorder and/or the instrumentation rate sensor saturated. The highest observed yaw rate, over 133°/sec/in., occurred with the SAS on. This led to the addition of the straight-through yaw rate term.

As noted in Section II, the straight-through yaw rate gain (K_{ψ}^{ST}) was initially set at $.25 \frac{\text{in.}}{\text{rad/sec}}$. The SAS was flight tested at this gain in October 1973, and the high yaw rates at hover were again evident. The gain was then increased to $.475 \frac{\text{in.}}{\text{rad/sec}}$ and the data reported were obtained at this gain. Particular attention was given to yaw rate response at hover, and it was the judgement of the Honeywell project pilot that the yaw rate response of Figure 48 (with SAS) was tolerable. This response, taken in ground effect (altitude \approx 5 ft), is reproduced in a smoothed fashion as Figure 75.

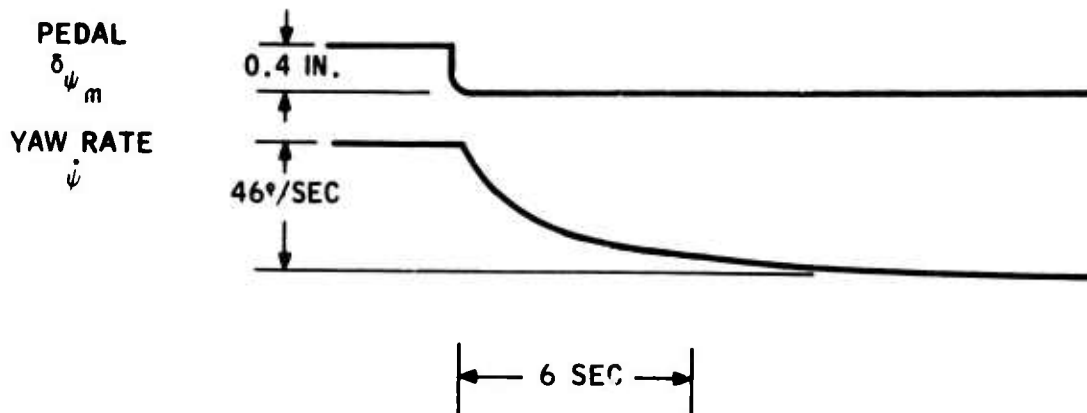

Figure 75. Maximum Allowable Yaw Rate Response at Hover.

It is used as a maximum response limit in judging the acceptability of all yaw rate responses at hover. All other hover responses meet this criterion.

SWITCHING TRANSIENTS

Paragraph 3.5.9 (a) of MIL-H-8501A states that there shall be no apparent switching transients as a result of SAS engagement. Examination of all the traces taken during flight test of the high-passed yaw rate configuration revealed no such transients. If they were present, they were within the noise threshold of the instrumentation rate sensor.

The lack of engage transients in the high-passed yaw rate configuration is due to the inability of steady-state signals to get through the high pass. When the straight-through term is added, null offsets due to temperature changes in the vortex rate sensor are passed on to the servo. This results in a slight transient in yaw when the SAS is engaged, as shown in Figure 74. No such transient is evident upon disengagement. Null offsets due to the pedal do not contribute to the transient, since the pedal input is summed in downstream of where the straight-through yaw rate is picked off.

AUTOROTATION

Paragraph 3.5.5 of MIL-H-8501A states that "... the transition from powered flight to autorotative flight shall be established smoothly, with adequate controllability, and with a minimum loss of altitude. . . ."

Autorotative entries were performed from 60kn, 90kn, and 110kn with the high-passed plus straight-through yaw rate system. The project pilot noted that the SAS made it easier to control yaw during throttle chop and power recovery. Figure 72 and 73 illustrate this in terms of smaller peak yaw rates with the SAS engaged.

PILOT COMMENTS - SUMMARY

Nine test pilots from military agencies and industry have evaluated the YG1105A01 fluidic stabilization system installed in the OH-58A test helicopter.

These pilots generally agree that the SAS provides good directional damping during cruise flight with an acceptable loss of control power. Some of the pilots, however, expressed a desire for increased directional damping in hovering flight. All pilots indicated that the engage-disengage characteristics of the SAS are excellent. Lateral maneuvers, and take-offs and landings are enhanced by the system, but increased performance is desired through optimization in hovering flight.

YG1105A01 (No Straight-Through Yaw Rate)

Comments made by Major John Smith and Major Robert Chaplin of ASTA *

"With the SAS on there was a reduction in directional control power and directional control response in both hover and forward flight. The reductions became smaller as forward airspeed was increased and were not detectable to the pilot at cruise airspeed (90 KIAS). The forward flight directional controllability characteristics of the OH-58A with the SAS engaged were satisfactory for the VFR or IFR mission."

"Qualitatively, there was a slight reduction in pilot effort required to hover with the SAS on; however, considerable effort was still required to precisely maintain a position over a spot." Correction of the lack of directional damping in a hover is desired.

"With the SAS on, yaw oscillations in left sideward flight between 10 and 20 KTAS were significantly reduced and pilot effort required to maintain desired heading was decreased. The sideward flight characteristics with the fluidic yaw damper installed are satisfactory for the VFR mission."

* Ltr., To Director of Eustis Directorate, U. S. AMRDL, "Fluidic Yaw Damper Installed on the OH-58A Helicopter," December 8, 1972.

"A qualitative flight was made in light to moderate turbulence. The increased damping provided by the SAS reduced the pilot effort to maintain a level flight trim attitude."

"Previous evaluations of the OH-58A have shown that the aircraft develops an undamped lateral directional oscillation (Dutch roll) when placed in a slight sideslip. This flight condition was experienced in the test aircraft with the SAS off. While the aircraft was oscillating, the yaw SAS was turned on and the lateral directional oscillations damped out immediately. Likewise it was not possible to excite the oscillations once the SAS was turned on. Elimination of this undesirable aircraft oscillation enhances the ability of the aircraft to perform IFR or VFR missions."

"The standard OH-58A has neutral spiral stability. If the aircraft is displaced in the roll axis from level trim by a gust, it will not return to the level trim condition. This evaluation revealed that the yaw damper improved the spiral stability of the aircraft from neutral to convergent. This characteristic significantly enhances the IFR capability of the aircraft by reducing the pilot effort required to maintain a desired heading. The directional dynamic stability characteristics of the OH-58A with the fluidic yaw damper installed are satisfactory for the IFR mission."

"A limited qualitative evaluation was conducted during level flight, sideslips, and maneuvering flight to determine if there were adverse effects when the SAS was suddenly turned off. (No hardover testing was conducted.)"

"The evaluation revealed that the aircraft reactions following a sudden SAS failure were very mild. During all the tests, delays greater than three seconds were possible before corrective action was necessary following a failure. It was also found that the system could be turned on during any flight condition, including maneuvering flight, without waiting for the SAS actuators to center. Also, the engagement transients were hardly detectable to the pilot even in a steep turn. The absence of delay time to activate the SAS and the minimal engagement transients are enhancing characteristics of the fluidic yaw damper. Within the scope of this test, the automatic stabilization system characteristics are satisfactory for the IFR or VFR missions."

Comment made by Mr. Ron Earhart (BHC):

The system worked very well and did as good a job as the electronic SAS used on the Jet Ranger (A paraphrase by H. I.).

Comment made by Mr. Duane Simon (U. S. Army):

"The system did not have enough gain. It was not stiff enough for the needs of the aircraft." (H. I. comments: This particular system did not have any temperature compensation, and at the time he flew the aircraft the outside temperature was a maximum of 15°F on the ground. We know that the oil temperature was only about 80°F and that the system gain was not up to usual performance.)

Comments made by Mr. Donald Sotanski (H. I.)

There is no significant roll or yaw transient when the SAS is engaged either in steady-state flight or maneuvering flight. There is a slight, nonobjectionable disengage transient.

The loss of control power with the SAS engaged is negligible. Decreased control power can be detected by repeated hover maneuvers with and without the SAS. In forward flight, it is difficult to detect a loss of control power.

The standard OH-58A has hydraulically boosted flight controls in the roll and pitch axis only. The yaw axis flight control system is purely mechanical; thus, a wide range of friction levels exists for the anti-torque pedals in any fleet of standard OH-58A aircraft. It is not unusual to find relatively high pedal breakout forces and decreasing pedal force required with pedal displacement from neutral or trim position. This condition, coupled with the light roll control forces required, leads to a tendency to over-control, especially during landings from a hover. Pilot induced roll-yaw oscillations are frequently encountered, especially by pilots transitioning in the aircraft.

The addition of hydraulic boost in the yaw axis of the test aircraft partially eliminates the high breakout force problem but does not provide a positive force gradient. It is obvious, however, that the addition of hydraulic boost and yaw stabilization reduces the pilot effort required to land from a hover or lift-off from a hover. The tendency of pilot induced roll-yaw oscillations is reduced, especially during down wind landings and gusting wind conditions.

With the SAS engaged, fixed pedal landings from a three foot hover can be accomplished with left turns ranging up to approximately 45 degrees. The same maneuver, performed with the SAS off, often results in a 180 degree left turn.

It is recognized that the SAS has not been designed for hover operations, thus the author feels that superior SAS performance in hover is highly desirable and can be achieved.

The unaugmented aircraft is underdamped in yaw and roll -- making precise control or instrument flying difficult. The SAS provides excellent damping in the yaw axis, providing deadbeat response to steps and pulses. A measure of additional roll stability is also apparent during SAS operation. The Dutch roll characteristics of the aircraft are eliminated with SAS engagement. This feature will reduce pilot fatigue during prolonged flights.

The characteristic left yaw experienced as a result of a throttle chop is reduced both in magnitude and rate with the SAS engaged. Control of the aircraft during autorotation entry and recovery is enhanced by use of the yaw SAS.

It is recommended that the system be modified to provide optimum damping in a hover as well as during cruise flight. It is the author's opinion that the average operational pilot would prefer augmentation during hovering maneuvers over cruise for contact flight. Both roll and yaw augmentation during cruise should be provided for any actual instrument flight in the OH-58A aircraft.

YG1116A01 (Incorporating Size and Weight Reductions, Temperature Compensation, and Straight-Through Yaw Rate):

Comments made by Lt. Com. John O'Boyle and Lt. Com. George Rowell (U. S. Navy Training Command, Pensacola, Florida):

"The system helped in the hover mode, particularly in downwind hovering. The OH-58A and TH-57 have different characteristics with the TH-57 more in need of a SAS." (H. I. Note: Both pilots evaluated the system from the standpoint of whether the system had any bad features that would interfere with student training. Their conclusion was that "they could find nothing detrimental." [H. I. paraphrase].)

Comments made by Mr. R. A. Balzer and Mr. B. Ganguish (Boeing-Vertol):

They felt that the system did a good job for the OH-58A but that other vehicles such as the BO-105 would need a three axis system, and gain scheduling versus airspeed for the yaw axis would be required. (H. I. paraphrase).

Comments made by Mr. Duane Simon (U. S. Army) *

"The fluidic yaw SAS installed in the OH-58A worked very well and appears ready for demonstration to the operational community."

However, in terms of production hardware the system still exhibited a shortcoming identified in previous Government evaluations that relates to a "yawing windup." Since the last evaluation, Honeywell incorporated a modification to the SAS in an attempt to eliminate or minimize the windup problem. The modification succeeded in transforming the response to a left pedal step input from an acceleration to a rate, as desired; but, it had no noticeable effect on the angular response to a right pedal input.

The reason for this discrepancy was unknown at the time of the evaluation, but it appears that the contractor is working at the problem since the fix worked satisfactorily in one direction. The "yawing windup" problem should be resolved before proceeding with an ASTA evaluation. Should the Eustis Directorate proceed with plans to expand the system to include roll SAS, it will again be necessary for the contractor to investigate and optimize gains and shaping. This should be followed by another Directorate flight evaluation before proceeding with "selling-type" demonstrations.

Comments made by Maj. Donald Couvillion (U. S. Army):**

"One flight was conducted in the OH-58A. The only augmentation in this aircraft was in yaw. The OH-58A normally is notoriously unstable in yaw. The yaw augmentation resulted in a noticeable improvement in handling. There was a marked improvement in yaw control with the channel engaged."

Comments made by Mr. Donald Sotanski (H. I.):

All of the foregoing comments pertaining to the YG1105A01 SAS equally apply to the YG1116A01 SAS. Additional comments are as follows:

* Memorandum for Record, "Pilot Comments on UH-IM and OH-58A Fluidic SAS, "January 4, 1974, Duane R. Simon

** Memorandum, Mr. George N. Fosdick from Maj. Donald A. Courillion, "Pilot Comments on the Honeywell 3-Axis Fluidic Stability Augmentation System (FSAS)," December 18, 1973.

Responses to a constant pedal input at hover in a standard OH-58A is a yaw acceleration. The yaw acceleration is such that sustained input could result in loss of control. The SAS provides yaw rate approximately proportional to pedal input; however, the response to a right pedal input is an acceleration. It should be noted that during right pedal turns the characteristic acceleration of angular motion is quite evident as the aircraft passes through the downwind position. This "downwind acceleration" is not evident during left pedal turns.

The cause for the right pedal turn malfunction should be determined and corrected. It is the author's opinion that a perfect angular rate proportional to pedal position is not required; a decrease in angular acceleration would be satisfactory. This opinion is based on the belief that a pilot will not allow the angular rate in a pedal turn to build to a dangerous level.

H. I. Note: Lack of damping during right turns at hover was traced to a nonlinearity in the rate sensor circuit. This is presently being investigated and will be reported in the final report on Contract No. DAAJ02-73-C-0056.

CONCLUSIONS

Based on the flight data presented in this report, the following conclusions have been drawn:

- Either SAS configuration will satisfy yaw damping requirements at forward flight speeds.
- Addition of the straight-through yaw rate term effectively limits steady-state yaw rate buildup in hover.
- Neither SAS configuration has a deleterious effect on directional control power.
- Angular velocity buildup in yaw is marginally out of specification limits for the free aircraft. Neither SAS configuration has a significant effect.
- The high-passed yaw rate configuration is noticeably free of engage transients. Addition of straight-through yaw rate compromises the engage transient only slightly.
- The high-passed plus straight-through yaw rate configuration aids the pilot in accomplishing autorotative flight.

LIST OF SYMBOLS

$\delta_{\downarrow m}$	pedal position - in.
$\dot{\psi}$	yaw rate - rad/sec, deg/sec
$\delta_{\psi m}$	roll cyclic stick position - in.
$\dot{\phi}$	roll rate - rad/sec, deg/sec
$\delta_{\theta m}$	pitch cyclic stick position - in.
$\dot{\theta}$	pitch rate - rad/sec, deg/sec
$\delta_{\downarrow s}$	yaw servo ram displacement - in.
$\delta_{\theta o}$	collective stick position - in.
v	lateral velocity - ft/sec
ϕ	roll attitude - rad, deg
δ_R	tail rotor actuator displacement - in.
$K_{\downarrow ST}$	straight-through yaw rate gain - $\frac{\text{in.}}{\text{rad/sec}}$
$K_{\downarrow HP}$	high-passed yaw rate gain - $\frac{\text{in.}}{\text{rad/sec}}$
τ	vortex rate sensor transport delay - sec
T_1	yaw rate high-passed time constant - sec
K_{δ}	pedal gain - in. / in.
N_r	yaw damping derivative
ω_n	natural frequency - rad/sec
ζ	damping ratio

LIST OF SYMBOLS (Concluded)

T	transport delay
Y_v	lateral force due to lateral velocity
Y_p	lateral force due to roll rate
G	gravitational constant - 32.2 ft/sec ²
U_o	forward velocity
Y_δ	lateral force due to tail rotor deflection
Y_A	lateral force due to lateral cyclic stick
Y_r	lateral force due to yaw rate
L_v	rolling moment due to lateral velocity
L_p	rolling moment due to roll rate
L_r	rolling moment due to yaw rate
L_δ	rolling moment due to tail rotor deflection
L_A	rolling moment due to lateral cyclic stick
N_v	yawing moment due to lateral velocity
N_r	yawing moment due to yaw rate
N_p	yawing moment due to roll rate
N_δ	yawing moment due to tail rotor deflection