

AD-784 385

DESIGN AND DEVELOPMENT OF THE 190-TON  
STABLE SEMISUBMERGED PLATFORM (SSP)

T. G. Lang, et al

Naval Undersea Research and Development  
Center

Prepared for:

Office of Naval Research

July 1974

DISTRIBUTED BY:

**NTIS**

**National Technical Information Service  
U. S. DEPARTMENT OF COMMERCE  
5285 Port Royal Road, Springfield Va. 22151**



**UNCLASSIFIED**

SECURITY CLASSIFICATION OF THIS PAGE (When Data Entered)

20. (Continued)

more deck space and internal volume. The SSP is 89-feet long and has a top operating speed of about 25 knots with about 25 tons of payload and fuel. Design of the SSP features two parallel torpedo-like hulls which support an above-water cross structure by means of four vertical surface-piercing struts; two canard fins are located near the hull bows and a cross stabilizing fin is located near the hull sterns. The SSP was constructed at the Coast Guard Shipyard at Curtis Bay, Md.

**UNCLASSIFIED**

SECURITY CLASSIFICATION OF THIS PAGE (When Data Entered)

## **CONTENTS**

**INTRODUCTION . . . 2**

**CHARACTERISTICS . . . 3**

**Dimensions and General Physical Description . . . 3**

**Performance Predictions . . . 6**

**Payload and Range . . . 8**

**Static Stability . . . 8**

**Dynamic Qualities . . . 8**

**DESIGN FEATURES . . . 10**

**Structure . . . 10**

**Propulsion System . . . 10**

**Control System . . . 12**

**Auxiliary Systems . . . 12**

**Miscellaneous . . . 13**

**CONSTRUCTION . . . 14**

**CONCLUSIONS . . . 15**

**REFERENCES . . . 17**

**BIBLIOGRAPHY . . . 19**

## INTRODUCTION

The 190-ton<sup>1</sup> Stable Semisubmerged Platform (SSP) was designed and built to be a work platform for research and testing of advanced Naval equipment at the Naval Undersea Center. The twin-hulled SSP configuration was selected for its unique qualities as a stable ocean platform in a wide range of sea states. The platform design is based on the twin-hulled semisubmerged ship concept (S<sup>3</sup>) [1].<sup>2</sup> Because of its role as a workboat, the SSP outfitting is minimal, omitting acoustic quieting and most comfort items. Its basic design, however, will provide valuable early information for the Navy's Small Waterplane Area Twin Hull (SWATH)<sup>3</sup> craft. The SSP measures 89 feet in length and has the reduced motion, increased deck space, and higher speed capabilities of a much larger conventional monohull vessel.

Design of the SSP began at NUC in March 1970, following 1½ years of research.<sup>4</sup> Figure 1 shows an underside view of the SSP that has two submerged, parallel, torpedo-like hulls which support a cross structure above water by means of four streamlined, vertical, surface-piercing struts. Two controllable canard fins are located near the hull bows, and a full-span stabilizing fin with controllable flaps is located near the hull sterns. The fins provide dynamic stability, damping, and control over heave, pitch, and roll. The vertical struts, via their displacement and spacing provide the necessary static stability in heave, pitch, and roll.

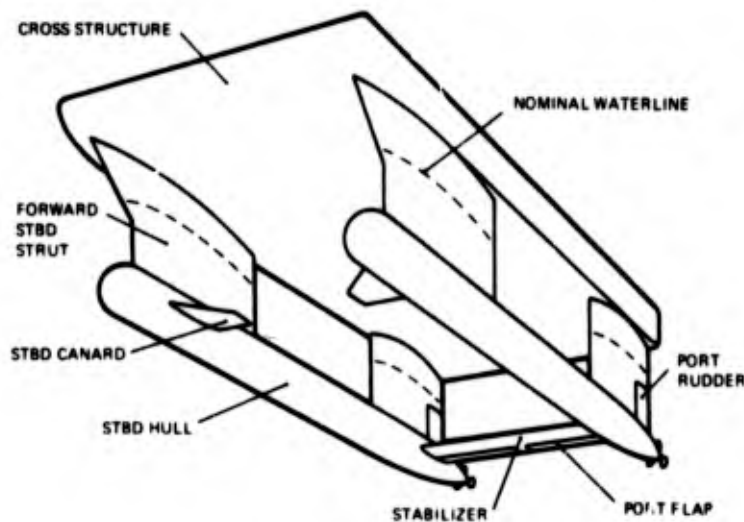

Figure 1. Underside view of the SSP.

<sup>1</sup>All tons referenced are measured in long tons.

<sup>2</sup>Numbers in brackets designate References at end of paper.

<sup>3</sup>A number of names or acronyms have been used in the past to describe different configurations of small waterplane area twin-hulled ships. MODCAT (Modified Catamaran) TRISEC, SEMCAT, LWP (low Waterplane Catamaran) and S<sup>3</sup> (Semi-submerged Ship) are examples. In order to avoid confusion, due to the multiplicity of names for the combination of various design options possible, the Navy refers to all such vehicles as Small Waterplane Area Twin Hull (SWATH) craft. The

<sup>4</sup>SSP is a two strut per hull version of this type of surface craft.

Sponsored by the Independent and Exploratory Development (IED) program at NUC under Dr. William B. McLean.

Future versions may have smaller stabilizing surfaces which consist of individual fins cantilevered from the hull tail cones; also, additional rudders may be included in the forward struts to permit even greater turn rates and independent control over yaw and sway.

The new design feature of the basic SSP concept over previous SWATH-type designs (some of which are mentioned in reference [1]) is the combination of submerged hulls and streamlined struts with a stabilizing fin or fins at the rear; the canards are optional but serve to improve the dynamic damping of motion and aid in trim and control. The stabilizing fins help insure dynamic stability at the higher speeds.

Additional information on SSP-type designs is available [2-6]. Other noteworthy SWATH-type concepts include the SEMCAT discussed by Freinkel [7], the TRISEC design presented by Leopold [8], and various designs studied by the Naval Ship Research and Development Center (NSRDC) [9, 10].

This paper presents an overview description of the design and development of the SSP. Reports covering specific areas, such as hydrodynamics, propulsion system, trial results, etc., will be forthcoming at a later date. The general characteristics, design features, and construction highlights of the SSP are discussed. The concluding section outlines the impact that this type of craft may have on the Navy, oceanographic research, and the ocean community in general.

## CHARACTERISTICS

### Dimensions and General Physical Description

The SSP dimensions are shown in Figure 2. The submerged hulls and struts are made of high tensile steel, with the struts joined directly to the aluminum cross structure. Propulsion is provided by two gas turbines that drive controllable and reversible pitch propellers through novel four-tier chain drives. Heading control is provided by twin rudders at higher speeds and differential thrust at low speeds. Provision for dynamic motion and trim control is incorporated in the design and consists of forward port and starboard canards and port and starboard flaps in the aft stabilizer. The rudders and movable control surfaces are hydraulically powered. Each of these subsystems is further described in later sections.

The SSP design was based on requirements that it (a) provide support for submersibles and various types of Naval equipment, (b) perform normal operations in up to 8-foot waves (the platform is to be used offshore from the NUC Hawaii laboratory where 8-foot waves are common), and (c) be of sufficient size and shape to demonstrate the effectiveness of the  $S^3$  concept in the open ocean. A center well, which measures 12.5-feet wide by 23 feet long, can handle a variety of small research submersibles including NUC's transparent hulled NEMO, MAKAKAI, and DEEP VIEW [11]. The SSP will also provide excellent surface support during the development phase of NUC's 20,000-foot Remote Unmanned Work System (RUWS).



Figure 3 shows the compartment layout of the SSP which provides for manned access down each of the four struts. The compartments aft of the pilot house are watertight with the exception of the aftermost outboard compartments which house the propulsion machinery and the two small outboard compartments just aft of the pilot house. The forward compartments in the submerged hulls are designed for interchangeable nose sections: a transparent acrylic dome for underwater observation, special sonar domes, and steel domes for normal use.

In addition to the forward section, each submerged hull is divided into six 2000-gallon ballast tanks and an aft tailcone. The forward three tanks contain fuel cells which separate the turbine fuel from the ballast water. The next three tanks aft are designed to contain ballast water only, and the tailcone section contains the propeller shaft and thrust bearing.

Safety features<sup>5</sup> include the watertight integrity of the cross structure, a fire control system, automatic inflating life rafts, radios, radar, fathometer, and running lights. Safety and reliability are further enhanced by the twin-hulled design which leads naturally to dual propulsion, fuel, and ballast systems.

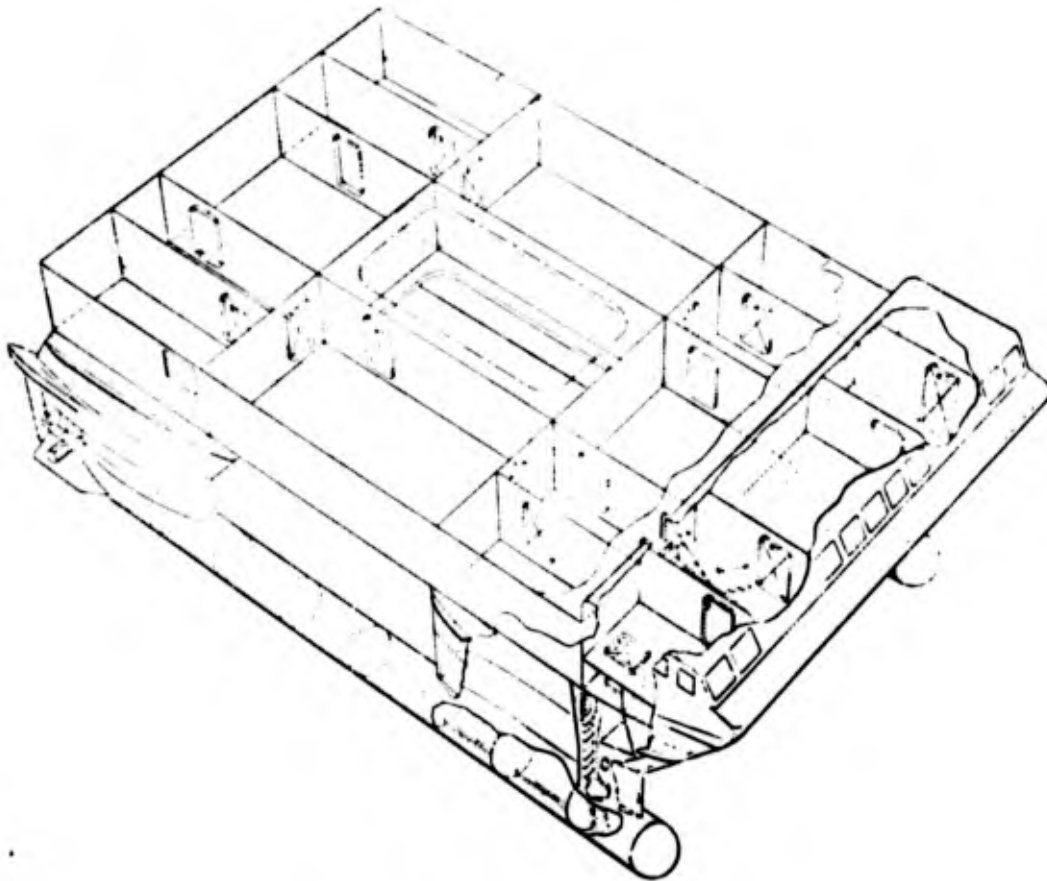

Figure 3. SSP compartment layout.

<sup>5</sup>A safety review sponsored by NAVSHIPS (R. Dilts) and conducted by NAVSEC (under the direction of T. Sarchin) in July 1971 verified the safety of the SSP with some minor changes and led to many helpful design suggestions.

## Performance Predictions

The SSP design form was based on a combination of model tests and theory. The design is somewhat similar to one of the earlier towed models [2], but it has a greater fore-and-aft strut spacing and incorporates the addition of canard fins sized according to the theory presented by Higdon [12].

Early towed model tests [2, 3] indicated that the struts should be spaced fore and aft as far as possible in order to reduce heave and pitch in following waves; associated motion tests showed that the metacentric height in roll should be roughly  $\frac{3}{4}$  of a hull diameter, although as little as  $\frac{1}{4}$  of a hull diameter is acceptable. The tests also verified that stabilizing fin(s) were necessary for pitch stability at moderate-to-high speeds.

Figure 4 shows a 5-foot radio-controlled model that was built to further explore the dynamic behavior, model drag and hydrodynamic coefficients, the effect of wind and waves, and to simulate the results of control surface failure, hull flooding, towing, and anchoring of the SSP. The radio-controlled model tests [3] showed no dynamic problems at any speed or any angle to waves, although the largest motion occurred in following waves. Experimental and theoretical results show that the SSP should operate well under all conditions through its design sea state 4. Slamming is expected in head seas in sea state 5, although the automatic control system to be installed at a later date should reduce impacts. Seven different bow shapes were tested to determine which would produce the least impact force. The vertical gap between the hulls and cross structure would permit waves up to the gap height of 14.75 feet to pass without cross-structure impact or exposure of the hulls if level flight were maintained.

The radio-controlled model was found to be nearly critically damped in heave, pitch, and roll when underway therefore resonance should not be a serious problem. Good damping was exhibited at rest. The model behaved acceptably in simulated waves up to the tank limit of 18 feet and in simulated winds up to 100 knots. The model towed well in wind and waves, although tow speed should be kept below wave speed in large following waves. It responded well at anchor except for side-to-side swing in the higher winds; a Hammerlock moor would eliminate swing.

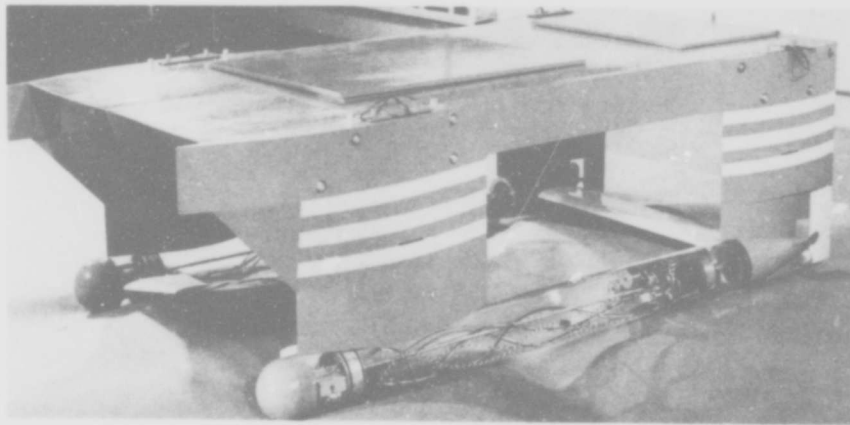

Figure 4. Five-foot radio-controlled model of the SSP.

Tests conducted in the spring of 1971 on an 11-foot self-propelled model of the SSP at NSRDC verified the basic design calculations and the 5-foot radio-controlled model results. Drag measurements were within about 15 percent of early predictions and agreed very closely with later theoretical predictions [6]. The theoretical drag coefficients and effective horsepower predicted by Dr. R. B. Chapman for the SSP are shown in Figure 5 together with prototype predictions from the 5-foot model tests. Propeller guard drag was not included but is calculated to be small. At the continuous rating of 4200 hp, the predicted speed is 25 knots, assuming a propulsive coefficient of 77 percent. Greater power and speed are available for shorter periods. Power requirements reduce significantly with draft; thus, increased speed will result if expended fuel is not replaced by ballast water or if the payload is reduced. The predicted SSP speed and power compare favorably with the following reported speeds and powers for similar-sized monohulls [13]: 143 tons, 3600 hp, 24 knots; 202 tons, 3200 hp, 23 knots; 146 tons, 4000 hp, 24 knots; 123 tons, 3000 hp, 25 knots. Since the SSP speed will change little in rough water while monohull speed degrades rapidly, the SSP should significantly outperform equivalent-sized monohulls in rough water.

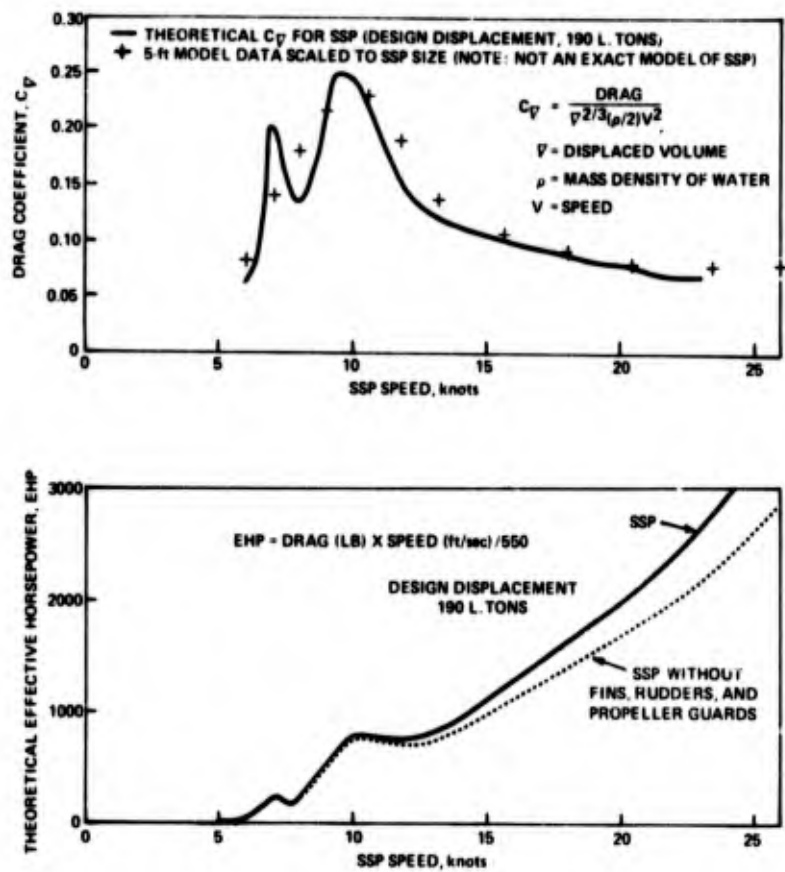

Figure 5. Drag coefficient and predicted effective horsepower of the SSP.

## **Payload and Range**

The payload and fuel capacity of the SSP is 25 tons. With the full fuel complement of 18.8 tons, the range of the SSP will be about 400 nautical miles at 25 knots.

## **Static Stability**

The large transverse spread of the strut waterplane areas, coupled with the nominally low center of gravity effected by the light aluminum cross structure, the heavier steel struts, and the submerged hulls, result in a platform with a relatively large metacentric height. With the entire 25-ton design payload centered 3 feet above the cross structure, the metacentric height in roll will be 4.4 feet, which is larger than that of a typical destroyer.

## **Dynamic Qualities**

Experience with the 5-foot radio-controlled model [3] showed that no dynamic problems existed. The model banked inward on turns without roll-control. Sufficient canard or flap control existed to make the model bank either more inward or even outward in turns. With only one propeller operating, the model controlled well; rudder trim for straight running was about seven degrees, and the model had no apparent side-slip.

The submerged hulls, large mass radius of gyration, and relatively small but wide-spread strut waterplane areas of this platform produce heave, pitch, and roll periods that are significantly longer than those associated with conventional monohull craft of similar displacement. The SSP should provide a more comfortable work platform than a conventional monohull since its motion response is expected to be considerably less under nearly all conditions.

The results shown in Figures 6 and 7 were generated by Higdon [3] and show the calculated heave and pitch of the SSP at 24 knots in head and following waves, assuming a wave length to height ratio of 20:1. Also shown in Figures 6 and 7 are the equivalent heave and pitch responses with an automatic control system and the required canard and flap deflections. Platform motion in head waves is extremely small. It is expected that the larger motions exhibited in following waves at higher speeds can be reduced considerably with automatic controls. Alternatively, following sea motion could be reduced by slowing the platform to a speed less than the wave speed. After the SSP has operated several months under manual control to demonstrate the inherently good response of the basic design form, it is planned to add an automatic control system.

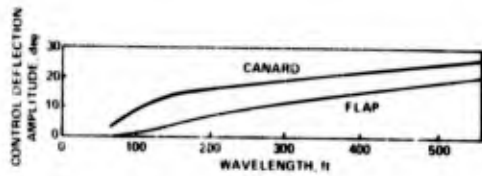
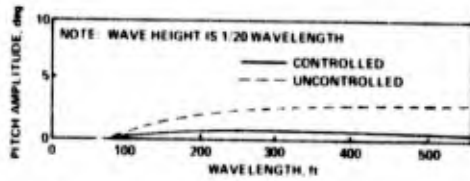
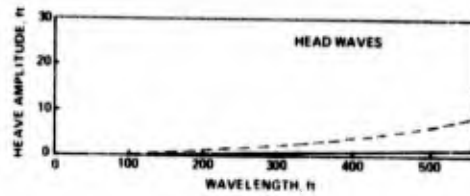

Figure 6. Predicted motion and control surface deflections of the SSP in head waves.

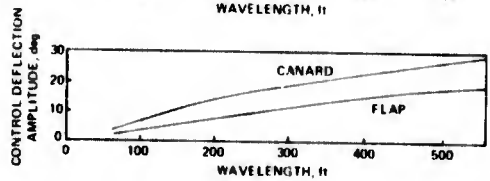
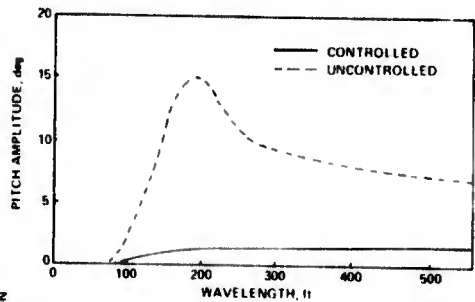
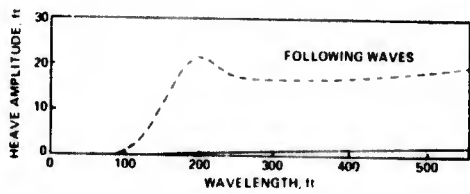

Figure 7. Predicted motion and control surface deflections of the SSP in following waves.

## DESIGN FEATURES

### Structure

The structural approach used for the SSP is basically that employed in conventional ship construction with standard structural shapes preformed and welded to preformed plates. The widely dispersed shape of the SSP leads naturally to a high structural weight fraction. Cost restraints in this first model prohibited the use of high strength, lightweight construction techniques to reduce weight.

The structure would have been fabricated entirely of steel, but early weight studies indicated, in view of the large desired margin of safety for the structure, that an all-steel structure would leave no margin for payload once the craft was fueled. Consequently, 5086 aluminum alloy was used for the cross structure, with high tensile steel (50,000 psi yield) used elsewhere.

Explosively bonded Detaclad strips of steel and aluminum alloy were used to join the steel struts to the aluminum cross structure, making an all-welded joint possible. Although this is not the first time this technique has been used to join steel and aluminum, it is probably the first time it has been used at main structural joints.

The SSP structural design<sup>6</sup> is based on a safety factor of 2.0 minimum. This, when coupled with the generally-conservative load assumptions and analytical assumptions, has resulted in a heavy structure. Tests at sea are expected to show that a significant reduction in structural weight fraction is possible in future SWATH platforms.

### Propulsion System

The size and hull form of the SSP has led to an interesting and unique propulsion system. The high structural fraction and tendency toward a heavy aft weight distribution necessitated the use of a lightweight power plant and speed reduction system. The GE-T64 gas turbine engine and gearbox were selected based on their availability in the Navy system. This engine and gearbox has a military rating of 3000 hp and weighs only 1200 pounds. Both of the two engines used on the SSP have been derated to approximately 2100 hp to extend the time between overhauls.

Initially, the design effort was centered around installing the turbines and gearboxes in the tailcones. However, it was soon discovered that it would be difficult to perform any maintenance on such an installation. The most obvious alternative was to locate the turbines in the cross structure, but the method for transmitting the power down to the propeller shaft presented a challenging engineering problem. Electrical and hydraulic systems were either too heavy, too expensive, or required an excessively long lead time. When specialists were consulted on the possibility of using a "Z" drive, they referred to past bad experiences and recommended looking at other alternatives. A low cost, short lead time power transmission system with a reasonable weight and success probability seemed unlikely until the use of chains was suggested by W. Simmons<sup>7</sup> who designed and developed the SSP chain drive and propulsion system illustrated in Figure 8.

---

<sup>6</sup>A large portion of the detailed design, both structural and nonstructural, was conducted by personnel assigned to Commander C. Kreitner at the Pearl Harbor Naval Shipyard.

<sup>7</sup>From the Naval Air Engineering Center.

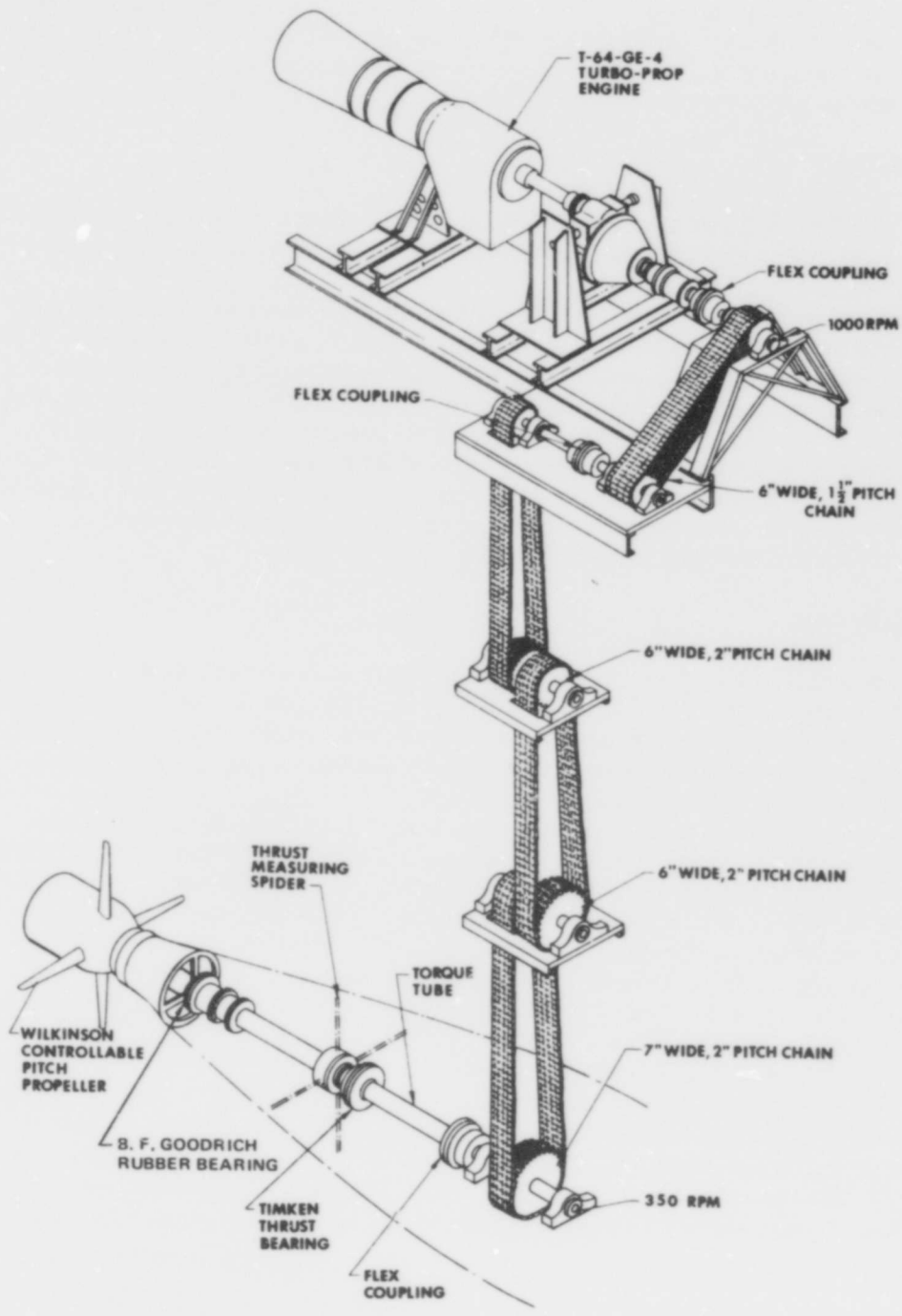

Figure 8. SSP propulsion system.

The SSP is equipped with a pair of 4-blade, 78-inch diameter Wilkinson CRPs (controllable, reversible pitch propellers). The Wilkinson CRP differs from other CRPs in that pitch change is accomplished by mechanical rather than hydraulic means. This leads to a simpler overall design, which provides lower initial cost and greater potential reliability.

### **Control System**

One of the principal advantages of the small waterplane hull form is its transparency to waves. This transparency results in a significant reduction in at-rest and underway platform motion.

Because the wave-induced forces are diminished, the forces needed to counteract and stabilize the platform are reduced in proportion. This allows the basic hull form to be fully stabilized with control surfaces of reasonable size and actuation power requirements.

The SSP rudders are operated together while each flap and canard can be actuated independently. Power for these control surfaces is provided by a hydraulic system. Two aircraft hydraulic pumps rated at 50 gal/min deliver fluid at 3000 psi to the system. Power to drive the pumps is taken off the main propulsion system gearboxes. A small 2 gallon/min pump driven by an electric motor provides fluid when the turbines are shut down.

Control is provided by a position feedback dc servo system.

### **Auxiliary Systems**

The SSP is equipped with most of the usual array of shipboard systems. It has two diesel generators, a 17.5 kW, 440V, 60 Hz and a 50 kW, 440V, 60 Hz, that supply electrical power. Salt water for cooling the generators, turbines, and hydraulic system is provided by two 5 hp centrifugal pumps; this system also supplies salt water to eductors for the bilge suction system and the fire mains.

The fuel system is unique in that the fuel is stored in 1000-gallon flexible containers located in the submerged hulls. Although this approach was initially selected to allow fuel and sea water to occupy the same tank without resulting in contamination of the fuel, several other advantages have been found to this approach. It satisfies environmental regulations by preventing contamination of ballast water, eliminates the tank vent and overflow problem, and eliminates condensation and condensate contamination of the fuel. Also, since the common sources of water in the fuel are eliminated, the bacteria problem should be eliminated (bacteria tend to grow in jet fuel at the fuel/water interface and can clog filters and pumps as well as turbine fuel controllers).

The ballast/trim system on the SSP uses air to dewater the ballast tanks and external hydrostatic head to flood them. An interesting aspect of this system is the high rate of trim change that can be obtained. Flooding one tank of twelve results in a roll rate of 3 deg/min. Flooding two forward tanks, one in each hull, can bring the bow down as much as 4 ft/min. These rates make it possible for the operator to quickly compensate for payload placement.

The front of one lower hull will be outfitted with the largest known monolithic acrylic casting, shown in Figure 9. This casting<sup>8</sup> is a hemisphere that measures 78 inches in diameter, is 6 inches thick, and weighs 5000 pounds. Its purpose is to allow scientists to view experiments from beneath the ocean surface. Other acrylic windows in the struts below the waterline allow the ship's control surfaces and propellers to be viewed while underway.

The SSP is equipped with a hand-held control unit which enables an operator to control the platform from any location on or below deck.

The radar is a newly developed product from the Naval Weapons Center, China Lake. The resolution of this unit is such that it is possible to distinguish the size and shape of passing ships. The display is in many respects more like a television picture than that of a radar.

Several secondary experiments have been designed into the platform. Of the six tanks which contain fuel bags, four have some form of built-in abrasion prevention system, while two have no special provision and act as controls. Also, the pilot, copilot, and navigator's seats are each equipped with various types of shock isolation hardware. Future tests with bow slamming are expected to indicate a preference in seating type.

#### Miscellaneous

The SSP has many other interesting features and equipment. Unlike most platforms, the SSP has an abundance of space and flat deck area. The top deck and most of the cross structure compartments are available for payload. Bulky items such as fuel are stored in the submerged hulls and struts. The only nonportable hardware that projects above the weather deck is the mooring cleats and chocks. When the well is covered, this deck provides approximately 2500 square feet of clear flat area.

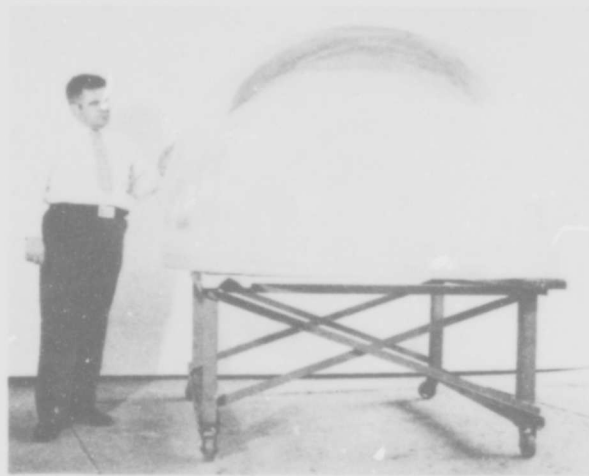

Figure 9. Acrylic hemisphere for one of the SSP hull noses.

---

<sup>8</sup>Designed by Dr. J. Stachiw at NUC.

## CONSTRUCTION

Construction of the SSP was accomplished at the U. S. Coast Guard Yard located at Curtis Bay just south of Baltimore, MD. This small yard, approximately 1000 personnel, is the only facility of its type operated by the Coast Guard. Its primary function is the construction and repair of Coast Guard vessels, but projects are accepted from other government agencies when the workload will permit or if special talents are required which are only available at the Coast Guard Yard. Construction of the SSP at this yard both smoothed out the workload and utilized the Coast Guard's experience with aluminum construction and gas turbine powerplants. The yard has also demonstrated on many occasions the ability to take on projects of an unusual design and complete them without difficulty, which has certainly proved to be the case with the SSP.<sup>9</sup>

Construction of the SSP began in June 1972. By February 1973 the major structural modules had been joined, as shown in Figure 10. Launching took place on March 7, 1973, followed by the installation of the engines, chain drives, and general outfitting. The first trial run occurred in October, 1973, in Chesapeake Bay, at the ground idle speed of 4 knots. On the very second day of trials, which took place in November, 1973, the SSP reached its design speed of 25 knots (according to the Kenyon log) after being tested in two-knot speed increments. Figure 11 shows the SSP underway at 14 knots. No photographs were obtained at higher speeds, although good motion picture coverage was obtained at various speeds up to the top speed of 25 knots. During trials in February, 1974, the upper jack shaft in one chain drive failed, causing a redesign and modification of the chain drive system.

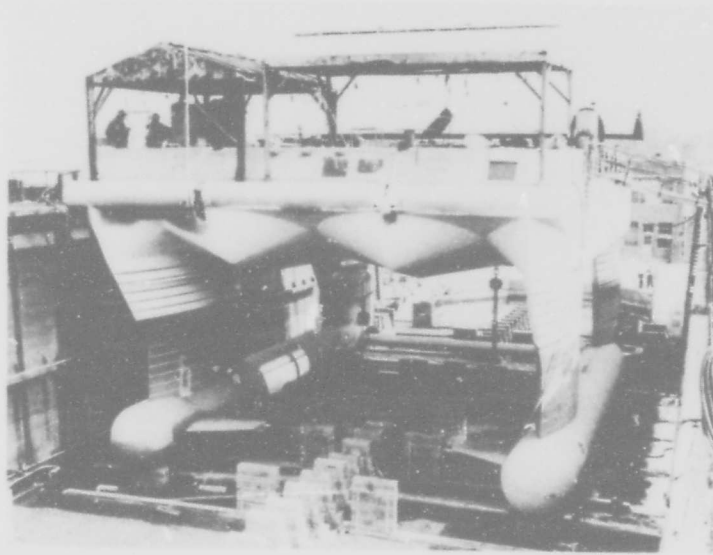

Figure 10. SSP modules being joined in drydock.

<sup>9</sup>Construction under the direction of Lieutenant J. Payne.

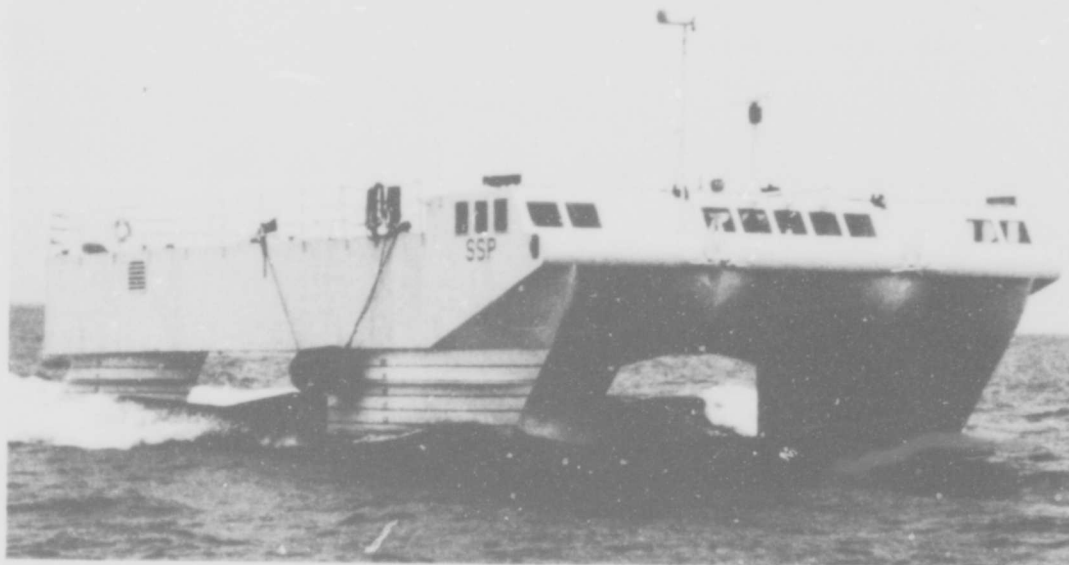

Figure 11. SSP underway.

### CONCLUSIONS

The 190-ton SSP should be an ideal platform for oceanic research since it is small, requires a crew of only four, has good range and speed characteristics, and is designed to operate through sea state 4 and into sea state 5. Further, it is designed for modular outfitting and has a well in the cross structure for handling undersea devices; a cover can be placed over the well for landing helicopters and small V/STOL aircraft.

Since the SSP is the first large manned version of a SWATH-type configuration, it may have considerable impact on the future Navy. Many of its characteristics can be scaled into larger sizes. For example, the 190-ton SSP operating at 25 knots in sea states 4 to 5 will behave similarly to a 3000-ton version operating at 40 knots in sea state 6. A 3000-ton Naval version would be large enough to support a sizable number of aircraft, weapons and missiles, sensor suites, or mixes thereof.

The SSP may also lead toward many kinds of nonmilitary use; for example, oceanic research by universities; crew boats or supply ships for the offshore oil industry; and cruise ships, transport craft, ferries, or fishing boats.

## REFERENCES

1. T. G. Lang, "S<sup>3</sup> - New Type of High-Performance Semisubmerged Ship," *Journal of Engineering for Industry*, Trans. ASME, Series B, Vol. 94, No. 4, Nov. 1972, pp. 1171-1178.
2. T. G. Lang, "S<sup>3</sup> Semisubmerged Ship Concept and Experimental Hydrodynamic Coefficients," *Naval Engineers Journal*, Apr. 1972, pp. 33-40.
3. T. G. Lang, and D. T. Higdon, "S<sup>3</sup> Semisubmerged Ship Concept and Dynamic Characteristics," AIAA Paper No. 72-604 presented at AIAA/SNAME/USN Advanced Marine Vehicles Meeting, Annapolis, Maryland, July 17-19, 1972.
4. R. B. Chapman, "Spray Drag of Surface-Piercing Struts," AIAA Paper No. 72-605 presented at AIAA/SNAME/USN Advanced Marine Vehicles Meeting, Annapolis, MD., July 17-19, 1972.
5. T. G. Lang, "Hydrodynamic Design of an S<sup>3</sup> Semisubmerged Ship," Paper presented at Ninth Symposium on Naval Hydrodynamics, Aug. 20-25, 1972, Paris, France.
6. R. B. Chapman, "Hydrodynamic Drag of Semisubmerged Ships," *Journal of Basic Engineering*, Trans. ASME, Vol. 94, No. 4, Dec. 1972, p. 879.
7. E. G. Frankel, "SEMCAT Report," Arthur D. Little, Inc., Report No. 63-1, June 1963.
8. R. Leopold, "A New Hull Form for High-Speed Volume-Limited Displacement-Type Ships," Society of Naval Architects and Marine Engineers, Paper No. 8, Spring Meeting, May 21-24, 1969.
9. R. Leopold, and R. S. Johnson of Naval Ship Engineering Center, Hyattsville, MD., and J. B. Hadler and P. Genalis of Naval Ship Research and Development Center, Carderock, MD., "The Low Water Plane Multi-Hull Ship Principles, Status, and Plans for Naval Development, AIAA Paper No. 72-603 presented at AIAA/SNAME/USN Advanced Marine Vehicle Meeting, Annapolis, Maryland, July 17-19, 1972.
10. N. Salvesen, "Seakeeping Characteristics of Small-Waterplane-Area-Twin-Hull Ships," *Journal of Hydronautics*, Vol. 7, No. 1, Jan. 1973, pp. 3-10.
11. H. R. Talkington, and D. W. Murphy, *Transparent Hull Submersibles and the MAKAKAI*, NUC TP 283, AD 738922, Feb. 1972.
12. D. T. Higdon, *Naval Feasibility Study of the S<sup>3</sup>, a New Semisubmerged Ship Concept*, Part III: Dynamics and Control, NUC TP 235, AD 889445L, Sept. 1971.
13. A. D. Baker, "Small Combatants 1973," *U. S. Naval Institute Proceedings*, May 1973, pp. 240-269.

## BIBLIOGRAPHY\*

- T. G. Lang. "A New Look at Semisubmerged Ships for the Navy." NUC TN-251,\*\* May 1969.
- L. A. Lacey. "Sea States and Shipboard Operator Performance and Maintenance." SRM 71-5 NPTRL, sponsored by NUC IED, December 1970.
- D. T. Higdon. "Estimation of Critical Hydrodynamic Loads on the SSP." NUC TN-553, June 1971.
- D. T. Higdon. "Estimates of SSP Attitude Resulting from Hard-Over Control Surface Failures." NUC TN-571, July 1971.
- D. T. Higdon. "Dynamics and Control of a Twin-Hulled Semisubmerged Ship (S<sup>3</sup>)." NUC TN-582, August 1971.
- T. G. Lang, et al. *Naval Feasibility Study of the S<sup>3</sup>, A New Semisubmerged Ship Concept, Parts I-VII*. NUC TP-235, September 1971. (Basically the same as TN-414-421, September 1970.)
- T.G. Lang, Part I, "Introduction, General Characteristics and Summary," DDC AD No. 889440L
- T.G. Lang, Part II, "Model Rest Results," DDC AD No. 889444L
- D.T. Higdon, Part III, "Dynamics and Control," DDC AD No. 889445L
- P.D. Burke, Part IV, "Structural Weight," DDC AD No. 889441L
- H.E. Karig, Part V, "Power-Plant Analysis," DDC AD No. 889446L
- J.L. Wham and R. M. Anderson, Part VI, "Sonar Potential," DDC AD No. 889447L
- P.L. Warnshuis, Part VII, "Operational Utility," DDC AD No. 889442L
- R. B. Chapman. *Spray Drag of Surface-Piercing Struts*. NUC TP-251, September 1971, DDC AD No. 730710.
- T. G. Lang, et al. "Preliminary Design Study of a 3000-Ton S<sup>3</sup>." NUC TN-574, September 1971.
- T. G. Lang and R. B. Chapman. "Hydrodynamic Design of the SSP – A 190-Ton High-Speed Stable Semisubmerged Platform of the S<sup>3</sup> Type." NUC TN-573, October 1971.
- W. J. Sturgeon, Jakus Associates. "A 3000-Ton S<sup>3</sup> World Port and Naval Drydock Compatibility Study." NUC TN-626, prepared for the Advanced Concepts Division in fulfillment of Contract N66001-71-6005DOU-2072, October 1971.
- T. G. Lang. "S<sup>3</sup>—New Type of High-Performance Semi-Submerged Ship." *Journal of Engineering for Industry*, Trans. ASME, Vol 94, pp. 1171-1178, November 1972. Presented at the ASME Winter Annual Meeting, New York, New York, 28 November - 2 December 1971.

---

\*This is a comprehensive Bibliography of the S<sup>3</sup>/SSP/SWATH program at NUC and is presented in chronological arrangement.

\*\*Technical Notes (TN) listed are working documents only and may be obtained with authorization from Code 608, NUC, San Diego.

- D. T. Higdon. "Canard and Flap Actuation Requirements for the SSP." NUC TN-694, February 1972.
- T. G. Lang. "S<sup>3</sup> Semisubmerged Ship Concept and Experimental Hydrodynamic Coefficients." *Naval Engineers Journal* (American Society Naval Engineers), pp. 33-42, April 1972.
- D. T. Higdon. "Horizontal Foil Systems for S<sup>3</sup> Ships." NUC TN-787, July 1972.
- T. G. Lang and D. T. Higdon. "S<sup>3</sup> Semisubmerged Ship Concept and Dynamic Characteristics." AIAA Paper #72-604 presented at the AIAA/SNAME/USN Advanced Marine Vehicles Meeting, Annapolis, Maryland, 17-19 July 1972.
- R. B. Chapman. "Spray Drag of Surface-Piercing Struts." AIAA Paper #72-605, presented at the AIAA/SNAME/USN Advanced Marine Vehicles Meeting, Annapolis, Maryland, 17-19 July 1971.
- H. O. Porter and A. T. Strickland. "Stable Semisubmerged Platform (SSP) Description." NUC San Diego - Hawaii Lab Brochure. August 1972.
- T. G. Lang. "Hydrodynamic Design of an S<sup>3</sup> Semisubmerged Ship." Paper presented at 9th Symposium on Naval Hydrodynamics, Paris, August 1972.
- P. L. Warnshuis and W. J. Sturgeon. "The Airbase Potential of Semisubmerged Ships." NUC TN-540, September 1972.
- P. V. H. Serrell, Consulting Mechanical Engineer. "Application of Light-Weight Materials and Light-Weight Structural Techniques to the Design of a 190-Ton Stable Semisubmerged Platform." NUC TN-868, prepared for the Advanced Concepts Division in fulfillment of Contract N66001-73-C-0068, October 1972.
- R. B. Chapman. "Hydrodynamic Drag of Semisubmerged Ships." *Journal of Basic Engineering*, Trans. ASME, Vol. 94, pp. 879-884, December 1972. Presented at the ASME Winter Annual Meeting, New York, New York, 26-30 November 1972.
- T. G. Lang, et al. "Outline of Proposed Trials for the Stable Semisubmerged Platform (SSP) and Cost Estimate of Proposed SSP Trials." NUC TN-839, December 1972.
- P. L. Warnshuis, "High-Speed Towing of Large Submersibles from Semisubmerged Ships." NUC TN-630, January 1973.
- U. W. Hird, Jakus Associates. "Dry Docking Alternatives for a 3000-Ton Semisubmerged Ship." NUC TN-916, prepared for the Advanced Concepts Division in fulfillment of Contract N66001-73-F-Q300, January 1973.
- P. V. H. Serrell, Consulting Engineer. "Structural and Mechanical Analysis of a Container Offloader Version of a Semisubmerged Stable Ship." NUC TN-973, prepared for the Advanced Concepts Division in fulfillment of Contract N66001-73-C-Q369, March 1973.
- R. B. Chapman. "Drag Measurement of Models of SWATH Ships and Basic SWATH Components." NUC TN-984, April 1973.

- D. T. Higdon. "Measured and Predicted Side Loads on a SWATH Ship Model at Rest in Regular Beam Waves." NUC TN-1072, June 1973.
- P. V. H. Serrell, Consulting Mechanical Engineer. "Preliminary Structural Design Report on a 3000-Ton Semisubmerged Stable Ship." NUC TN-1171, prepared for the Advanced Concepts Division in fulfillment of Contract N66001-73-C-0369, June 1973.
- P. V. H. Serrell, Consulting Mechanical Engineer. "Preliminary Structural Design of a 500-Ton Semisubmerged Stable Ship." NUC TN-1118, prepared for the Advanced Concepts Division in fulfillment of Contract N66001-73-C-0369, July 1973.
- W. J. Sturgeon and U. W. Hird, Jakus Associates. "A 500-Ton Modularly Outfitted Semi-submerged Ship - General Arrangement Study." NUC TN-1104 prepared for the Advanced Concepts Division in fulfillment of Contract N66001-73-C-Q299, August 1973.
- P. V. H. Serrell, Consulting Mechanical Engineer. "Design of Flight Deck for Light STOL Aircraft for NUC Stable Semisubmerged Platform." NUC TN-1194, prepared for the Advanced Concepts Division in fulfillment of Contract N66001-73-C-0369, August 1973.
- L. L. Bollinger and C. J. Feher, Consulting Engineers. "STOL Seaborne Operations Feasibility and Design Parameters." NUC TN-1238, prepared for the Advanced Concepts Division in fulfillment of Contract N66001-73-M-Q320, September 1973.
- P. V. H. Serrell, Consulting Mechanical Engineer. "Evaluation of Tradeoffs for a 500-Ton Semisubmerged Ship." NUC TN-1235, prepared for the Advanced Concepts Division in fulfillment of Contract N66001-73-C-0369, October 1973.
- M. G. Harris. "The Hydrodynamic Performance of Flap Actuated All-Movable Control Foils." NUC TN-1208, October 1973.
- R. L. Bedore. "Fuel Pod Towing from Semisubmerged Ships." NUC TN-1157, November 1973.
- D. L. Endicott. "SSP Control Surface Behavior Survey." NUC TN-1234, November 1973.
- W. J. Sturgeon, Jakus Associates. "A Semisubmerged Ship S<sup>3</sup> Conceptual Manning Study." NUC TN-1233, prepared for the Systems Analysis Group in fulfillment of Contract N66001-71-6005DOU2028, November 1973.
- P. D. Burke. "Structural Design Criteria for a 500-Ton Semisubmerged Ship." NUC TN-1237, November 1973.
- B. B. Dunne, President, Ship Systems, Inc. "Preliminary Assessment of the Survivability of the Semisubmerged Ship (S<sup>3</sup>)." NUC TN-1239, prepared for the Advanced Concepts Division in fulfillment of Contract N66001-73-M-Q223, November 1973.
- J. M. Smith. "Finite Element Analysis of a 500-Ton S<sup>3</sup> Aft Strut." NUC TN-1244, November 1973.
- N. B. Estabrook. "The Effect of Variations in Hull Geometry on the Drag of a 500-Ton S<sup>3</sup>." NUC TN-1245, November 1973.

- R. B. Chapman. "Lift and Trim Acting on SWATH Demihulls." NUC TN-1275, November 1973.
- T. G. Lang, J. D. Hightower, and A. T. Strickland. "Design and Development of the 190-Ton Stable Semisubmerged Platform (SSP)." ASME Paper #73-WA/OCT 2, presented at the ASME Winter Annual Meeting, Detroit, Mich., 11-15 November 1973.
- M. L. Sorensen. "A Comparative Study of Two Design Geometries for the 3000-Ton S<sup>3</sup>." NUC TN-1240, December 1973.
- T. G. Lang. "The 190-Ton Stable Semisubmerged Platform (SSP) – A New Concept in Marine Transportation." Presented with a model demonstration to the Governor's Conference on Mass Transit Statewide, Honolulu, Hawaii, 6-7 December 1973. (Available from: Code 608, NUC San Diego.)
- R. B. Chapman. "Sinkage and Trim of SWATH Demihulls." AIAA Paper #74-327, presented at the AIAA/SNAME/USN Advanced Marine Vehicles Conference, San Diego, California, 24-28 February 1974.
- T. G. Lang, and D. T. Higdon. "Hydrodynamics of the 190-Ton SSP." AIAA Paper #74-328, presented at the AIAA/SNAME/USN Advanced Marine Vehicles Conference, San Diego, California, 24-28 February 1974.
- P. L. Warnshuis. "Design Progress Toward a 500-Ton S<sup>3</sup>." NUC TN-1359, April 1974.