

**Best Available
Copy
for all Pictures**

AD-786 238

ADVANCED MARINE TECHNOLOGY:
BENTHIC ARRAY

William A. Prothero, Jr., et al

Scripps Institution of Oceanography

Prepared for:

Office of Naval Research
Advanced Research Projects Agency

July 1974

DISTRIBUTED BY:

NTIS

**National Technical Information Service
U. S. DEPARTMENT OF COMMERCE
5285 Port Royal Road, Springfield Va. 22151**

Unclassified

SECURITY CLASSIFICATION OF THIS PAGE (When Data Entered)

REPORT DOCUMENTATION PAGE		READ INSTRUCTIONS BEFORE COMPLETING FORM
1. REPORT NUMBER SIO Reference No. 74-24	2. GOVT ACCESSION NO.	3. RECIPIENT'S CATALOG NUMBER AD 786 238
4. TITLE (and Subtitle) ADVANCED MARINE TECHNOLOGY: BENTHIC ARRAY		5. TYPE OF REPORT & PERIOD COVERED 9/15/69-12/15/71 Final Report
		6. PERFORMING ORG. REPORT NUMBER AOEL Report No. 65
7. AUTHOR(s) Dr. William A. Prothero, Jr. Dr. Walter H. Munk		6. CONTRACT OR GRANT NUMBER(s) N00014-69-A-0200-6012
9. PERFORMING ORGANIZATION NAME AND ADDRESS Advanced Ocean Engineering Laboratory Scripps Institution of Oceanography P.O. Box 1529, La Jolla, Ca. 92037 714-453-2000, X2476		10. PROGRAM ELEMENT, PROJECT, TASK AREA & WORK UNIT NUMBERS NR 293-005
11. CONTROLLING OFFICE NAME AND ADDRESS Advanced Research Projects Agency Strategic Technology Office 1400 Wilson Blvd., Arlington, Va. 22209		12. REPORT DATE July 1974
14. MONITORING AGENCY NAME & ADDRESS (if different from Controlling Office) Office of Naval Research 800 N. Quincy Street Arlington, Virginia 22217		13. NUMBER OF PAGES 129
		15. SECURITY CLASS. (of this report) Unclassified
		15a. DECLASSIFICATION/DOWNGRADING SCHEDULE
18. DISTRIBUTION STATEMENT (of this Report) Approved for public release; distribution unlimited.		
17. DISTRIBUTION STATEMENT (of the abstract entered in Block 20, if different from Report)		
18. SUPPLEMENTARY NOTES		
19. KEY WORDS (Continue on reverse side if necessary and identify by block number) Instrument, seismic, undersea Noise, seismic, undersea, background		
20. ABSTRACT (Continue on reverse side if necessary and identify by block number) An ocean bottom seismic recording capsule has been designed, constructed, and tested. It contains a Block-Moore quartz torsion fiber accelerometer, a two-axis tilt-meter, a current speed meter, a thermometer, and digital recording and control electronics. The sensors and recording electronics are contained in three 22 inch I.D. pressure spheres made from Alcoa aluminum hemispheres. The capsule rests on the ocean floor without lines to the surface. Upon acoustic command, an explosive cable cutter separates the		

Reproduced by
NATIONAL TECHNICAL
INFORMATION SERVICE
U S Department of Commerce
Springfield VA 22151

DD FORM 1473
1 JAN 73

EDITION OF 1 NOV 68 IS OBSOLETE
S/N 0102-014-6001

Unclassified

SECURITY CLASSIFICATION OF THIS PAGE (When Data Entered)

Unclassified

SECURITY CLASSIFICATION OF THIS PAGE(When Data Entered)

positively buoyant instrument capsule from a support tripod and battery frame. The capsule then floats to the surface for recovery. The acoustic system has both command and diagnostic capabilities. Digital diagnostic data is transmitted to the surface at 100 bps. Microseisms and earthquakes have been recorded. The 6 second microseisms are approximately the same amplitude as on a fairly quiet land site. The 20 second noise is from the electronics, so at that period no comparison to land recordings is possible.

Unclassified

SECURITY CLASSIFICATION OF THIS PAGE(When Data Entered)

1a)

SCRIPPS INSTITUTION OF OCEANOGRAPHY
UNIVERSITY OF CALIFORNIA, SAN DIEGO
Dr. William A. Nierenberg, Director
Principal Investigator
ADVANCED OCEAN ENGINEERING LABORATORY
714-453-2000, X2476

BENTHIC ARRAY

Dr. Walter H. Munk and
Dr. William A. Prothero, Jr.

FINAL REPORT
July 1974

Sponsored by
ADVANCED RESEARCH PROJECTS AGENCY
ARPA Order Numbers 1348 and 1809
Program Codes 3N10 and 3E90

Administered by the OFFICE OF NAVAL RESEARCH
Contract N00014-69-A-0200-6012

SIO Reference Number 74-24

AOEL Report No. 65

Disclaimer

The views and conclusions contained in this document are those of the authors and should not be interpreted as necessarily representing the official policies, either expressed or implied, of the Advanced Research Projects Agency or the U. S. Government.

*Amount of Contract: \$3,723,951.00
*Effective date of Contract: December 15, 1968
*Contract Expiration Date: December 31, 1974

*These quantities reflect the cumulative funding of all ARPA-sponsored activities of the Advanced Ocean Engineering Laboratory of Scripps Institution of Oceanography over this 6 year period.

ie

TABLE OF CONTENTS

	Page
LIST OF FIGURES	ii
LIST OF TABLES	iii
LIST OF APPENDICES	iv
ABSTRACT	v
I. INTRODUCTION	1
II. CAPSULE CONFIGURATION	6
A. External Mechanical	6
B. Internal Mechanical	13
Accelerometer and Tiltmeter	15
Gimbal Leveling	17
Electronics Card Cage and Tape Recorder	23
C. Electronics	23
Analog Sensor Electronics	26
Motor Control Electronics	38
Acoustic Command System	41
Acoustic Diagnostic System	44
Gross Tilt, Leak and Release Electronics	49
III. OCEAN TESTING PROGRAM	53
IV. OVERALL CAPSULE EVALUATION	63
REFERENCES	65
APPENDIX I	66
Attachment 1	69
Attachment 2	70
Attachment 3	74
Attachment 4	76
Attachment 5	73
Attachment 6	80
APPENDIX II	84
APPENDIX III	96
APPENDIX IV	111

LIST OF FIGURES

FIGURE		PAGE
1.	Capsule external configuration	7
2.	Capsule support frame and batteries	8
3.	Assembled capsule	10
4.	Release system detail	11
5.	Internal capsule view	14
6.	Tiltmeter-simplified schematic	16
7.	Tiltmeter	18
8.	Girbal brake	19
9.	Accelerometer sphere components	21
10.	Solenoid accelerometer can lock	22
11.	Electronics card cage	24
12.	Electronics block diagram	25
13.	Capacitance bridge circuit	27
14.	Low noise preamplifier	28
15.	Gravimer amplifier	29
16.	Mixer and carrier generator	30
17.	Tuned amplifier	31
18.	Tide filter circuit	34
19.	Seismic filter circuit	35
20.	Filter gains	36
21.	Seismic filter magnification	37
22.	Brake motor control	40
23.	Automatic gravimeter zero circuit	42
24.	Diagnostics sheet	48
25.	Leak and gross tilt detector circuits	50
26.	Squib fire circuit	51
27.	Tide output-low resolution	54
28.	Tide output	55
29.	Seismic filter output	56
30.	Seismic filter output-Managua earthquake	57
31.	Seismic filter output from deep ocean deployment	59
32.	Power spectral density of ambient noise	60
33.	Noise spectra at Pinon Flats	62

LIST OF TABLES

TABLE		PAGE
1	Ocean Bottom Seismic Capsule CINDHI Specifications	3
2	Accelerometer and Tiltmeter	4
3	Acoustic Command System	5
4	Alert Codes for Diagnostics	45

LIST OF APPENDICES

	Page
I. Cable cutter development and testing	66
II. UCSD data logger	84
III. Results of the first ocean test of the ocean-bottom Block-Moore accelerometer package.	96
IV. Results of CINDHI ocean deployments 2 and 3.	111

ABSTRACT

An ocean bottom seismic recording capsule has been designed, constructed, and tested. It contains a Block-Moore quartz torsion fiber accelerometer, a two-axis tilt-meter, a current speed meter, a thermometer, and digital recording and control electronics. The sensors and recording electronics are contained in three 22 inch I.D. pressure spheres made from Alcoa aluminum hemispheres. The capsule rests on the ocean floor without lines to the surface. Upon acoustic command, an explosive cable cutter separates the positively buoyant instrument capsule from a support tripod and battery frame. The capsule then floats to the surface for recovery. The acoustic system has both command and diagnostic capabilities. Digital diagnostic data is transmitted to the surface at 100 bps. Microseisms and earthquakes have been recorded. The 6 second microseisms are approximately the same amplitude as on a fairly quiet land site. The 20 second noise is from the electronics, so at that period no comparison to land recordings is possible.

FINAL REPORT BENTHIC ARRAY

This report is concerned with the design, construction, and testing of an ocean bottom capsule containing a vertical Block-Moore quartz torsion fiber accelerometer (Block and Moore, 1970). A general description of the instrument is given in the introduction, detailed descriptions of individual components are given in the instrumentation section, and the results of ocean tests and data are given in the concluding section.

I. Introduction

The purpose of this instrument development program is to advance the technology of undersea instrumentation and acquire new data on ground motion under the deep ocean. For example, if the seismic background noise is found to be extremely low on the deep ocean floor, much smaller seismic signals could be observed than on noisier land sites. This would improve our ability to discriminate between nuclear explosions and earthquakes. In fact, the ocean bottom has been found by others (Bradner, *et al.*, 1970; Latham and Sutton, 1966; Schneider, *et al.*, 1964) to be noisier in certain frequency bands than quiet land sites. Ocean bottom noise data will be presented in this report.

The deep structure of the earth's crust and upper mantle can be studied using surface wave dispersion and the earth's normal mode excitation periods (6 sec to 1 hr). Information on structure beneath the recording station can be obtained by measuring deviations from idealized earth tidal amplitudes caused by loading from the ocean tides, and anomalies in the arrival times of teleseismic body waves.

The ocean bottom capsule itself is designed for deployment periods up to 90 days, with 30 days of self-contained recording capacity. It rests on the ocean floor without lines to the surface. A two-way acoustic communication system allows for transmission of 16 different commands from the surface ship to the capsule and also for digital diagnostic data transmission from the capsule to the surface ship. Alert codes which indicate commands received and tilt or leak conditions are also transmitted by the capsule. The capsule may be recalled to the surface by an acoustic command, or an internal timer set before capsule launch. Upon receipt of the release command, an explosive cable cutter is activated which severs a .5 inch steel cable which holds the capsule to its support tripod and battery frame. The positively bouyant instrument capsule then floats to the surface where it is recovered.

In addition to the vertical accelerometer, the capsule contains a two-axis tiltmeter, two thermometers to record capsule temperature and accelerometer temperature (it is temperature regulated) and a current speed meter. These sensor outputs are digitized and recorded on a low power incremental magnetic tape unit. The tape recorder was constructed for this project by R. Moore and is now being manufactured by Digi-Data Corporation. The low-power analog to digital converter has a 12 bit resolution and was designed and constructed for this project by R. Moore and J. Pastoriza and is being presently manufactured by Analog Devices Corporation. Tables 1, 2 and 3 are summaries of the capsule specifications.

A great deal of attention has been given to the recovery reliability of the capsule. In addition to careful checkout procedures, all likely failures are protected against by a diagnostic or by a backup device. For

TABLE I

OCEAN BOTTOM SEISMIC CAPSULE CINDHI SPECIFICATIONS

Depth Limit:	16,400 feet
Materials:	7178 Alcoa aluminum hemispheres hard anodized and epoxy painted
	7178 aluminum center ring - hard anodized
Stored Capacity:	1,000 amp-hours at 12 volts
Release:	Explosive cable cutter activated by a surface command
Weight:	Approximately 1600 lbs. including stand, batteries and internal instrumentation

RECORDING SYSTEM

Word Length:	12 bits
Dynamic Range:	1:4096
Input Voltage:	± 10 v.
Least Count:	5 mv.
Input Channels:	8
Storage Capacity:	2.5×10^6 samples on 2400 ft. reel 29 days at 1 sample/second
Maximum sample rate:	50/second by internal modification
Nominal sample rate:	1/second
Power Requirements:	12 v., 12.8 amp-hr. per reel of tape, independent of stepping rate

TABLE 2

ACCELEROMETER AND TILTMETER

Accelerometer Instrumental Noise:

Less than 5×10^{-23} ($\Delta g/g$)²/cph (1 cph to 1 Hz) for UCSD Camp Elliott, the land based unit at the seismic station. At 25 sec. period thru .02 Hz bandwidth digital filter, the noise is less than 15 millimicrons. ($M_s = 2.4$ at $\Delta = 30$).

Accelerometer Response: Flat to acceleration (DC to .2 Hz)

Power Requirements: 10 ma at 12 v.
10 ma at -12 v.
50 ma at 48 v. for temperature control

Analog Outputs

Tide Filter:

Response, D.C. to 1 cpm (3 db pt.)
Full Scale, $\pm 1.4 \times 10^{-5}$ $\Delta g/g$
Least count, 5×10^{-10} $\Delta g/g$

Seismic Filter:

Response, 1 cph to .1 Hz (3 db pts)
Full Scale, $\pm 1.4 \times 10^{-7}$ $\Delta g/g$ (in pass band)
Least Count, $\pm 3.4 \times 10^{-9}$ $\Delta g/g$ (in pass band)

Tiltmeter:

Full Scale, $\pm 3 \times 10^{-3}$ radians (two axes)
Least Count, $\pm 7.3 \times 10^{-7}$ radians

TABLE 3

ACOUSTIC COMMAND SYSTEM *

Range: 7 - 10 miles

Number of Commands: 10 commands (expendable)

Digital Diagnostic Telemetry

Transmission Rate: 100 bits/second, 4 readings/second

Voltage Resolution: 5 mv

Error Rate: When the signal is at least a factor of two above noise, the errors are usually zero. This is good for a diagnostic system where data with errors can be retransmitted. This system has performed very well for us.

Backup Diagnostic Telemetry

Range During Transmission: Must be nearly over the capsule

Backup VCO Diagnostic Telemetry

Transmission Rate: .5 bits/second, each bit transmitted as an alert code recognizable by ear.

Voltage Resolution: 5 mv.

Release: On command from surface

Backup Release: At a pre-set time from 0 to 9999 hours
(Completely self-contained)

Power Requirements: 2 ma at 24 v. quiescent
2 amps at 24 v. when transmitting

* The command and transpond portion of this system has been rather unsatisfactory. The source level is too low and the receiver is of a very poor design. Ocean testing of the diagnostic system has been trouble-free and worked quite well, however.

example, a leak in the capsule causes an acoustic alert code to be transmitted to the surface ship. A large leak automatically causes the capsule to release. Excessive tilts also initiate an alert code. If the acoustic command system or main release system fails, a separate cable cutter and timer releases the capsule. Dual radio beacons insure that the capsule can be located on the surface if one radio beacon fails.

The capsule has been deployed three times near San Clemente Island and deployed once for three weeks, 240 miles southwest of San Diego in the deep ocean. Background noise and a number of earthquakes were observed. These measurements will be discussed in detail later.

II. Capsule Configuration

A. External Mechanical

Figure 1 shows the external capsule configuration. The electronics is housed in three pressure spheres formed by six hemispheres and a center plate. Holes drilled in the center plate between spheres allows for instrument wiring between them. A fourth sphere is mounted above the three and provides additional buoyancy and stability. This assembly is connected to the support tripod by a .5 inch steel cable. The support tripod contains six 100 amp-hour lead-acid batteries and three 30 amp-hour batteries modified for deep sea use. Electrical cables from the batteries are taped to the steel connecting cable to form a 1 inch diameter bundle. The tripod is constructed from 2 inch steel pipe and welded together. Figure 2 is a photograph of the tripod and batteries. The foot pads, which rest on the ocean bottom, are 24 in. diameter steel tank ends. These limit the

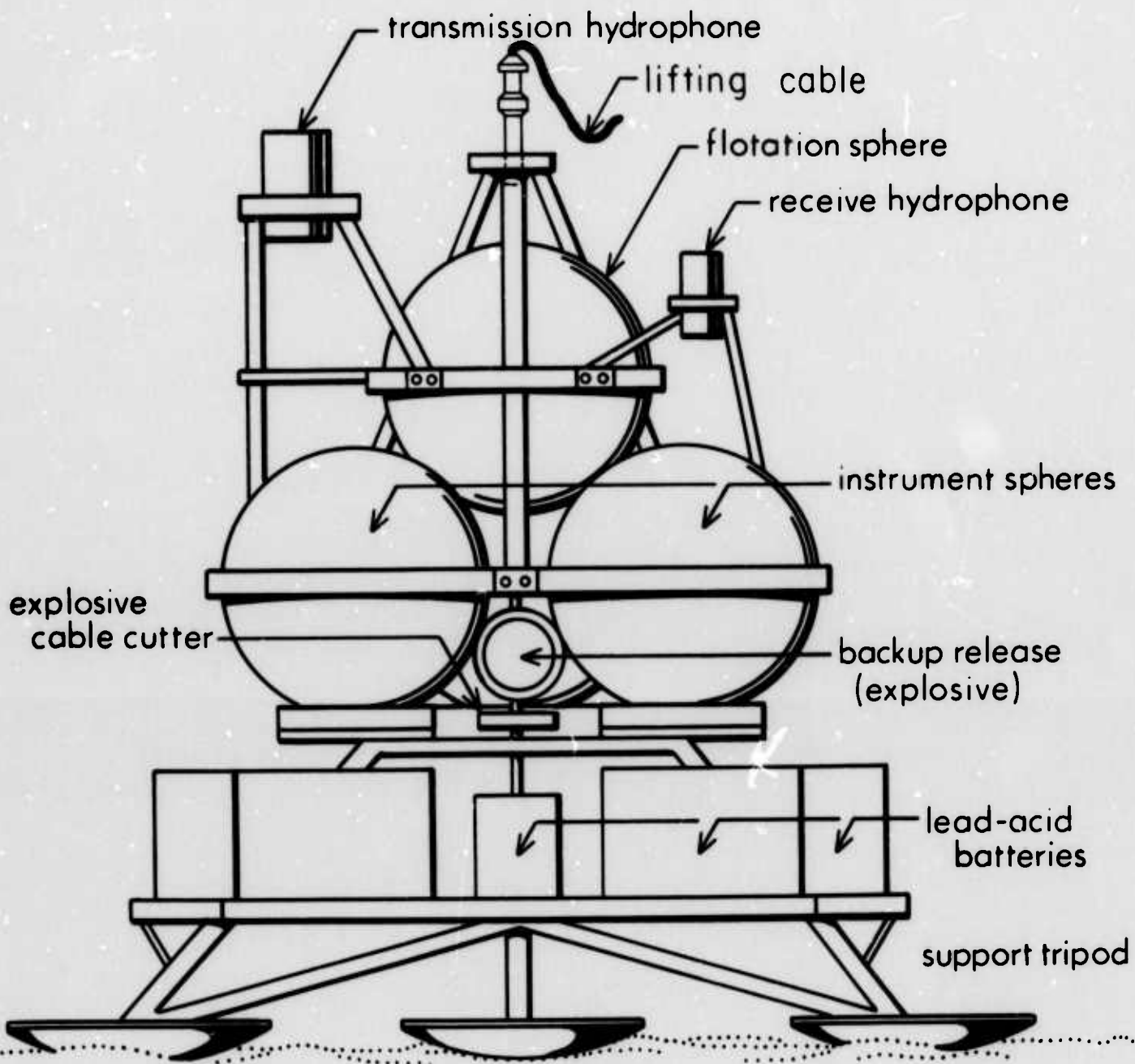

Figure 1

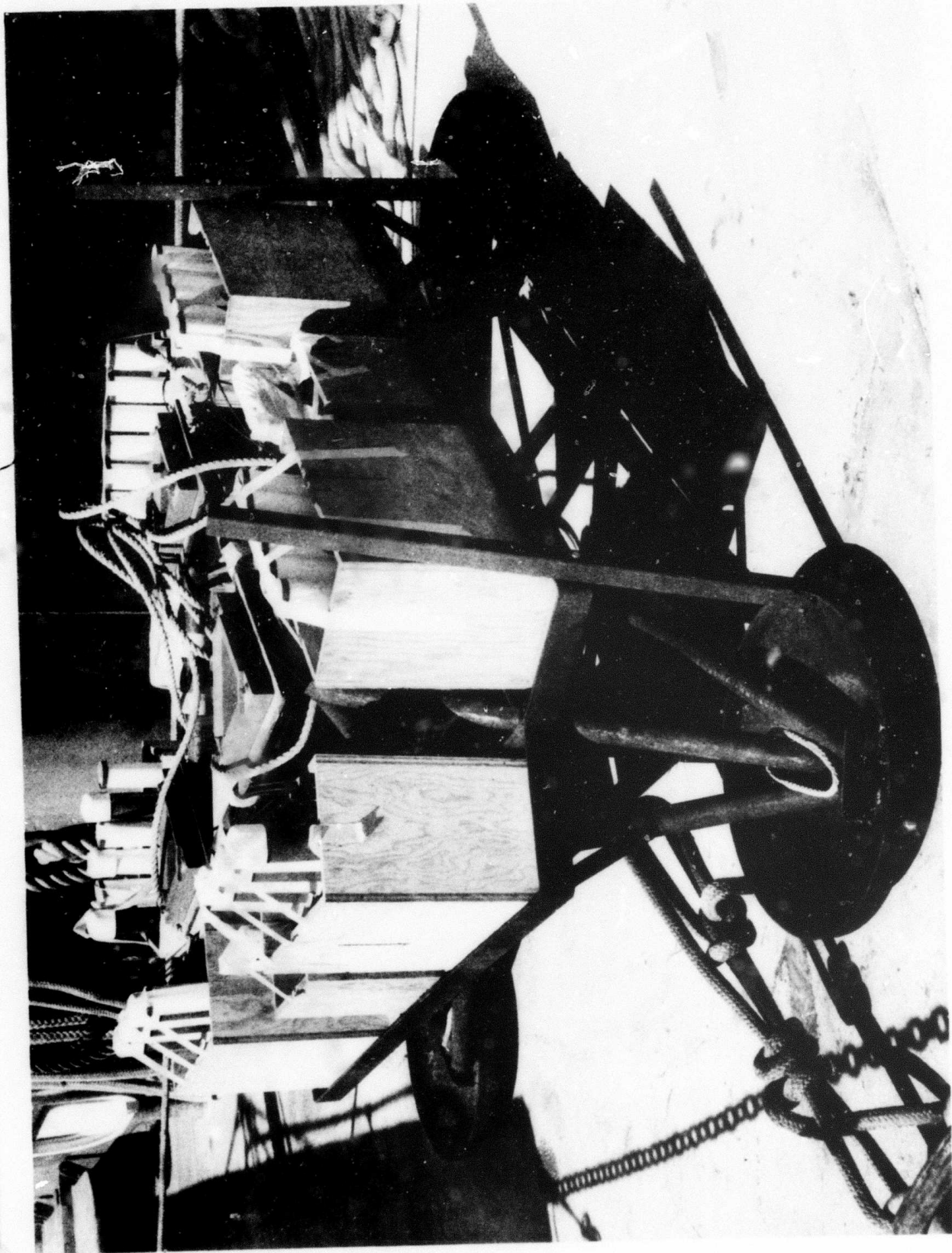

Figure 2

bearing pressure to less than 1 p.s.i. Figure 3 shows the assembled capsule ready for launch except for the radio beacons and acoustics transducers.

Figure 4 shows the capsule release and tripod connection assembly. The capsule is held to the tripod by the .5 inch steel cable. The three hemispheres rest on PVC triangles at the corners. At each corner, the pushoff springs provide a total of 300 pounds of force to insure a positive release. The cable tension is determined by tightening the eyebolts. At high pressure, the hemispheres will decrease in size, so the cable tensioning spring is strong enough to maintain positive contact between the bottom hemispheres and the support tripod.

Release is accomplished by cutting the cable and battery wires with the explosive cable cutter developed by W. Hill on this project (Appendix 1). This unit is now available from Horex, Incorporated. The main cutter is actuated by the acoustic command system. In the event of a failure, the backup unit releases the capsule at a preset time. The backup timer is simply a crystal oscillator with countdown circuits. A thumbwheel switch sets hours from 0 to 9999. The cable cutter is mounted directly on the end of the pressure case so that no electrical leads are exposed to the high pressure ocean environment. After release, the capsule floats to the surface, where it is located with the aid of two radio beacons and a flashing light.

The hemispheres which form the pressure housing for the instrumentation, are 24 inch O.D. ALCOA aluminum of alloy 7178. These were inexpensive at the time of purchase and were proven for deep ocean instrumentation. They are rated at 16,000 feet depth. For protection, they are hard anodized and painted with baked enamel. The anodizing may actually increase

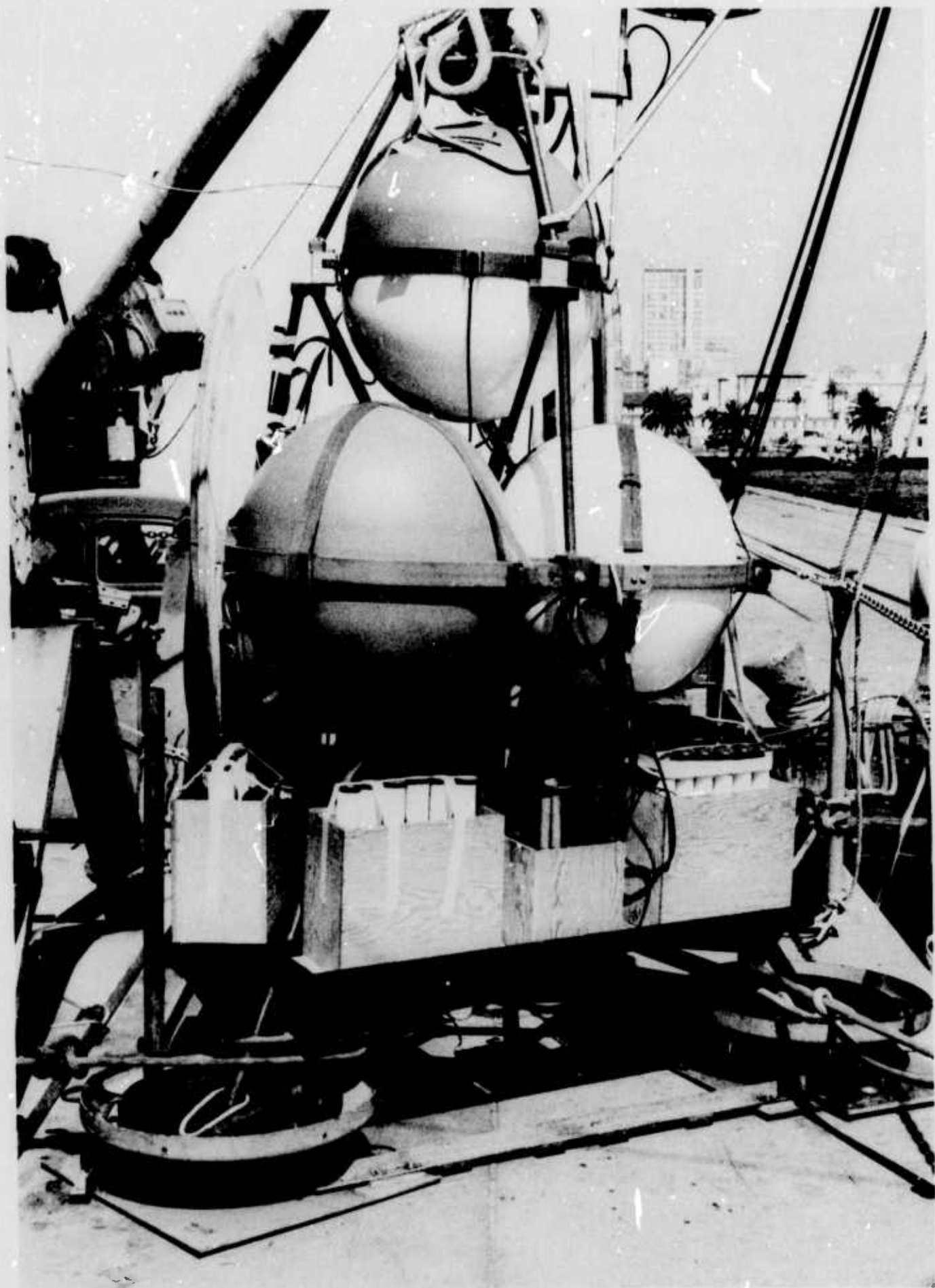
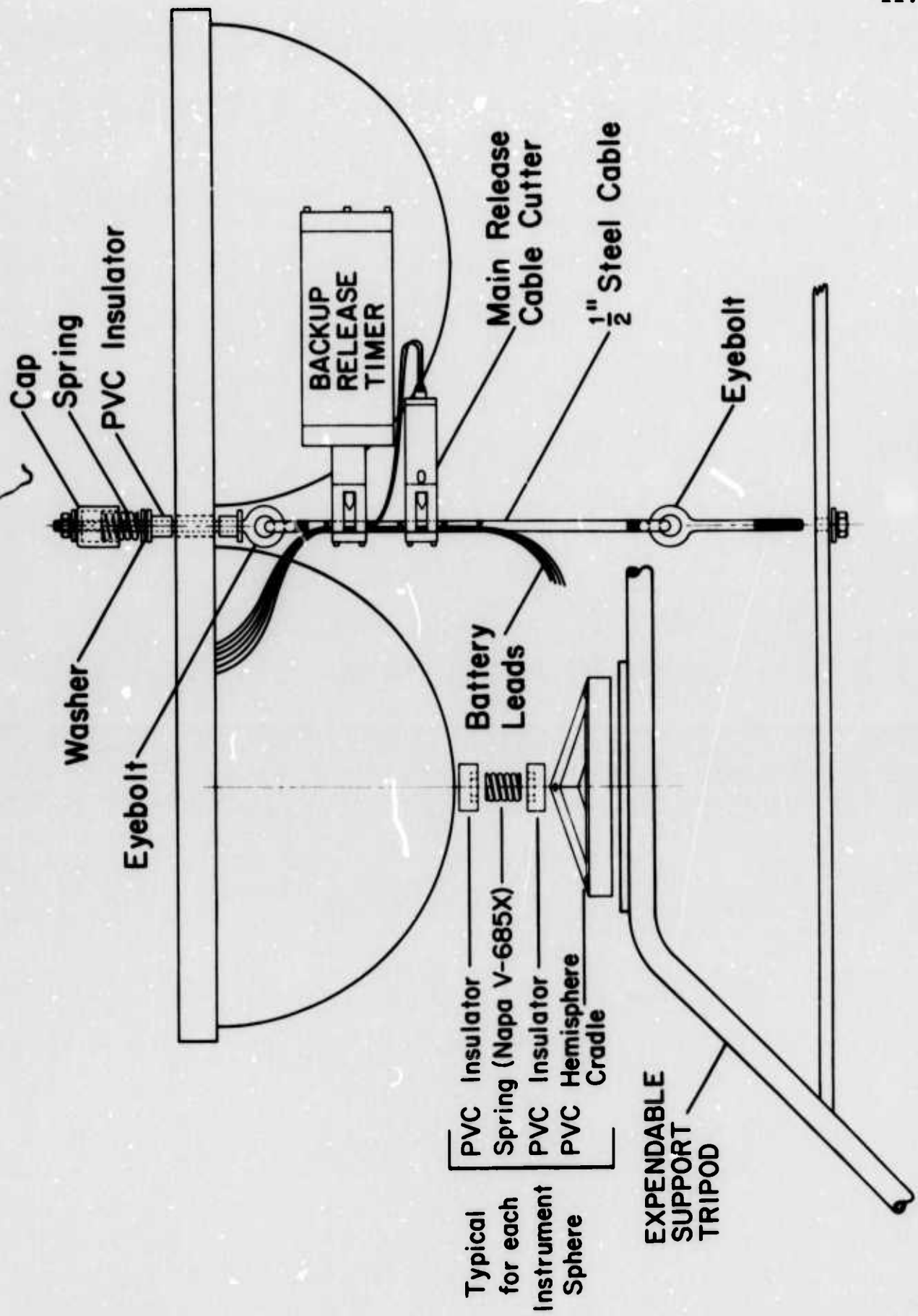

Figure 3



Typical
for each
Instrument
Sphere

- PVC Insulator
- Spring (Napa V-685X)
- PVC Insulator
- PVC Hemisphere Cradle

EXPENDABLE
SUPPORT
TRIPOD

RELEASE SYSTEM DETAIL

Figure 4

corrosion at pinholes in the coating, but is necessary in order to protect the o-ring surfaces from scratches. The baked enamel seems to adequately protect against this effect. Each bottom hemisphere contains two leak detectors, which consist of parallel strips of lead foil. The electrical resistance between the strips decreases when salt water passes over them. Two strips around the upper edge, which can respond to a single drop, cause an acoustic alert to be transmitted. Parallel tapes raised 1/8 inch off the bottom indicate a flood condition, which automatically releases the capsule. Initially, even a single drop of water in the capsule was considered serious enough to warrant automatic release of the capsule. However, if the ship is not in the vicinity, release may mean the capsule will be lost. A few drops per day could be tolerated. However, if a puddle develops, the best chance of recovery will be had by release.

Each hemisphere is sealed to the center plate by means of a single 5-547 Buna-N o-ring. The internal components are mounted on the center plate. Holes are drilled in the plate to allow for wires running between components in different spheres. The top sphere is empty except for leak detectors. It is connected to the lower unit by a tubular aluminum frame. The lower instrumentation hemispheres may be removed when the upper sphere is in place. The hemispheres are held in position by evacuating them to an internal pressure of 1/2 an atmosphere. Pressure gauges are connected until just before launch. The hold-down force resulting from this method is sufficient to withstand any reasonable abuse. The capsule was once severely banged on a hemisphere when being handled by a crane. The hemisphere remained attached. Nylon straps have provided protection in case of

accident, but would not be used in the future. The vacuum hold-down also has the advantage that the o-ring is seated properly against the inside of the o-ring groove, lessening the chance of low pressure leaks.

The capsule is deployed by lowering it on 3/4 inch hollow braided polypropylene line. When it is on the bottom, a surface buoy is secured to the end. The capsule is acoustically interrogated until proper capsule functioning is verified. Then a command is given which fires an explosive bolt to release the buoy line at the capsule. The capsule rests on the bottom until the desired recovery time. For recovery, after the capsule is on the surface, a coil of line connected to the lifting fixture (previously securely taped to the capsule) is snagged with a boat hook and the end is spliced to a line through the crane. The line is pulled through the crane, pulling the capsule toward the ship until the lifting fixture is inside the cranehead. The crane head has a mechanism which locks onto the lifting fixture so that the line no longer holds the capsule weight.

B. Internal Mechanical

Figure 5 is a photograph showing the overall arrangement of the main internal components of the capsule. The accelerometer, tilt-meter, and gimbal system are contained in the front ring. The right rear ring contains the analog and digital electronics, which are mounted on circuit boards that plug into a card cage. The left rear ring contains the low power incremental tape recorder and acoustics transmit, receive, and command decoding electronics. It is normally mounted horizontally above the tape recorder. The tape recorder, acoustic system, and card cage are mounted to the center plate through shock mounts. This greatly reduces vibration

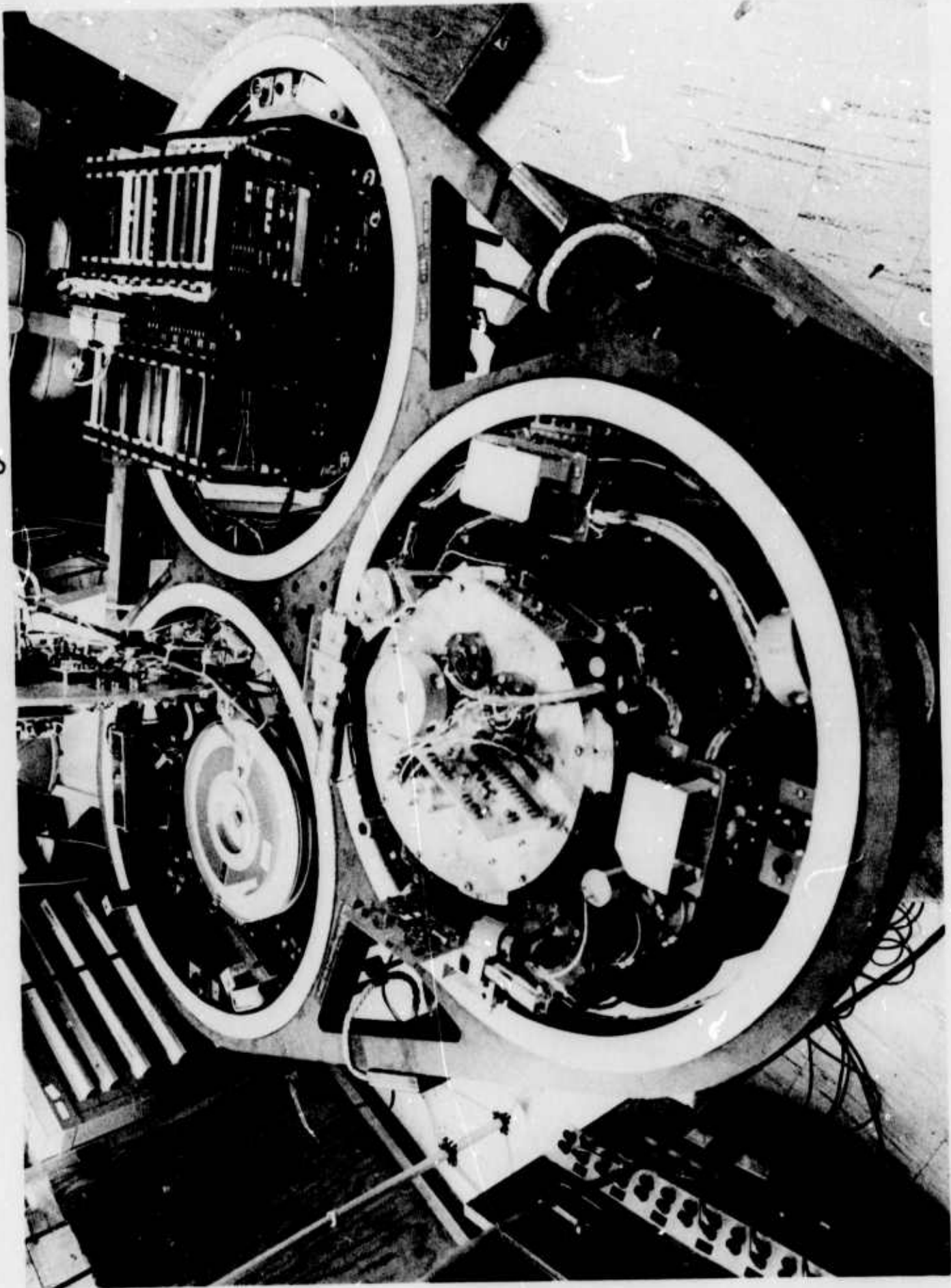
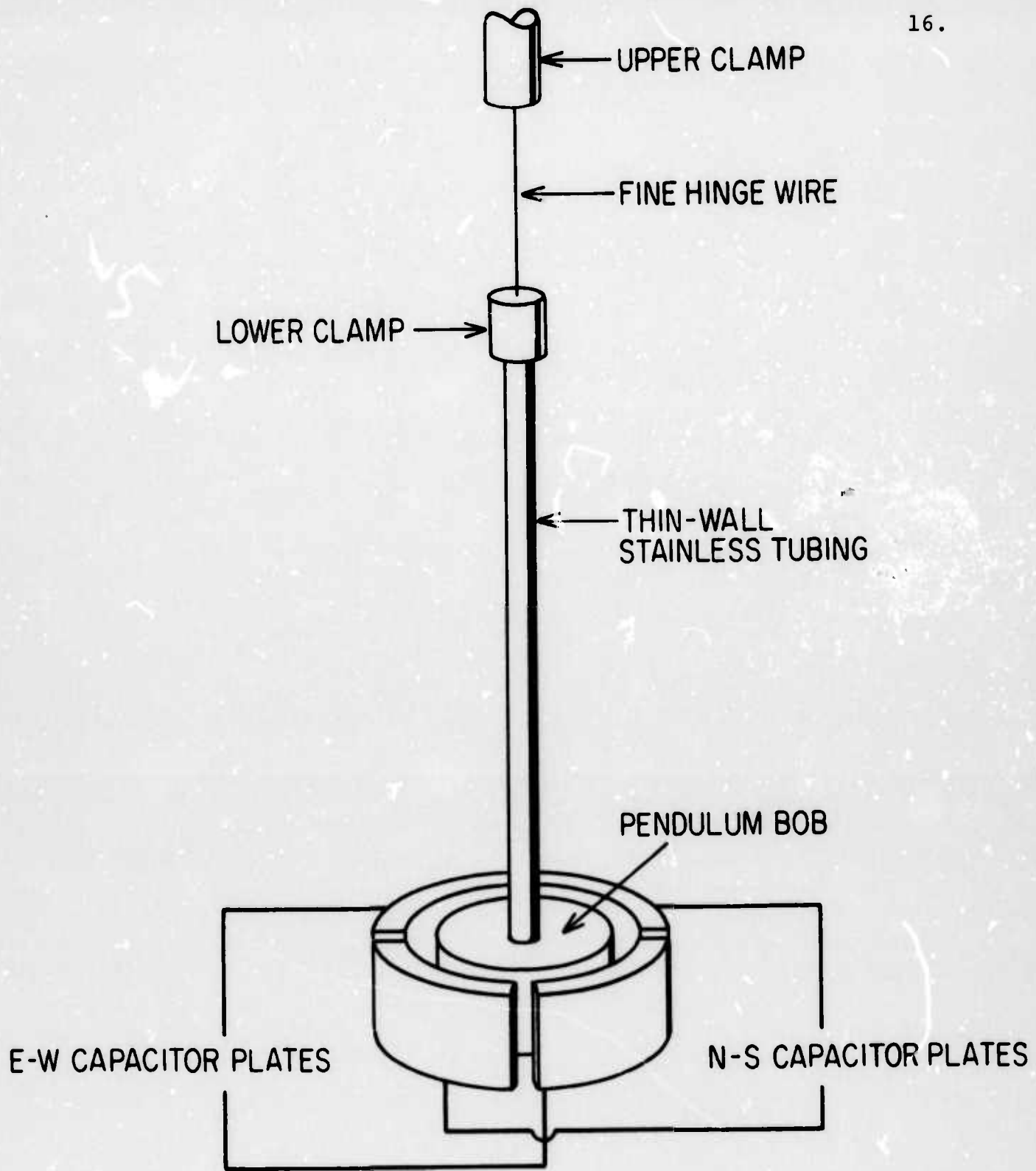

Figure 5

of critical components enroute to the deployment site. During the first deployment, a screw vibrated loose from inside the accelerometer, requiring a great deal of work to replace it. The entire capsule is vibration isolated by supporting the foot pads of the tripod on shock-mounted dishes (see Figure 2). All threaded joints are also secured with lock-tite. With these precautions, no further trouble with ship's vibration was encountered.

Accelerometer and Tiltmeter

The accelerometer has been described in detail elsewhere (B. Block and R. Moore, 1970), so will not be discussed here. Figure 6 is a simplified diagram of the tilt-meter developed for this system. Its purpose is to measure gross capsule tilts to correct the accelerometer, which has a $\cos\theta$ response to off-vertical tilts. This unit was developed by R. Moore and W. Hill. It consists of a simple pendulum hanging on a fine wire. Four plates arranged symmetrically around the mass are used in a capacitance bridge similar to that used in the accelerometer to sense its position. The capacitance from the bob to one plate is compared to the capacitance between the opposite plate and the bob. The E-W plates are driven at 1024hz and the N-S plates are driven at 4096hz. The voltage induced on the bob is a sum of the two frequencies and is proportional to the distance off center. The signals are separated and passed through phase-sensitive detectors. The D.C. outputs are then a measure of the tilt on the two axes. The full scale outputs on each axis are $\pm 3 \times 10^{-3}$ radians which is large enough to encompass variations in level point of the pendulous gimbal leveling. The smallest resolveable signal on the 12 bit data logger is then 1.5×10^{-6} radians. This is more than adequate to correct for accelerometer tilting.



TILTMETER, SIMPLIFIED SCHEMATIC

Figure 6

A motor and screw arrangement clamps the bob as shown in Figure 7. The bellows insure that the can is vacuum tight. It is filled with dry nitrogen at atmospheric pressure so that moisture variations (water has a dielectric constant of 80) do not interfere with the position measurement. In practice, the unclamping arrangement was somewhat unreliable. When the capsule cooled to a few degrees C. as it was lowered to the seafloor, the clamping mechanism would occasionally jam and not unclamp. For future uses, less delicate, smaller, and cheaper tilt-meters which would suit our purposes are available from Radian Corporation and Autonetics. As no clamping would be required for these units, this problem would be eliminated entirely.

Gimbal Leveling

The object of the gimbal system is to put the accelerometer fairly close to the vertical after the capsule has been deployed. Corrections for signals introduced by tilting are determined from the tilt-meter output. The most difficult engineering in the gimbal system was the brakes. They must open completely, clamp the gimbals rigidly, and draw no power in the quiescent state. Figure 8 shows the disc brake arrangement finally arrived at. A small D.C. motor drives a wedge on a threaded rod. The wedge moves against a moving shoe, which clamps tightly against a vane. During the clamp cycle, the motor is shut off when it draws a predetermined amount of current. The unclamped state is indicated by a microswitch, which shuts off the motor / ^{circuit.} This arrangement provides an extremely rigid and reliable clamp. The only problem occurred because the microswitch was unreliable. It was replaced by a magnetically actuated reed relay and no further trouble was encountered.

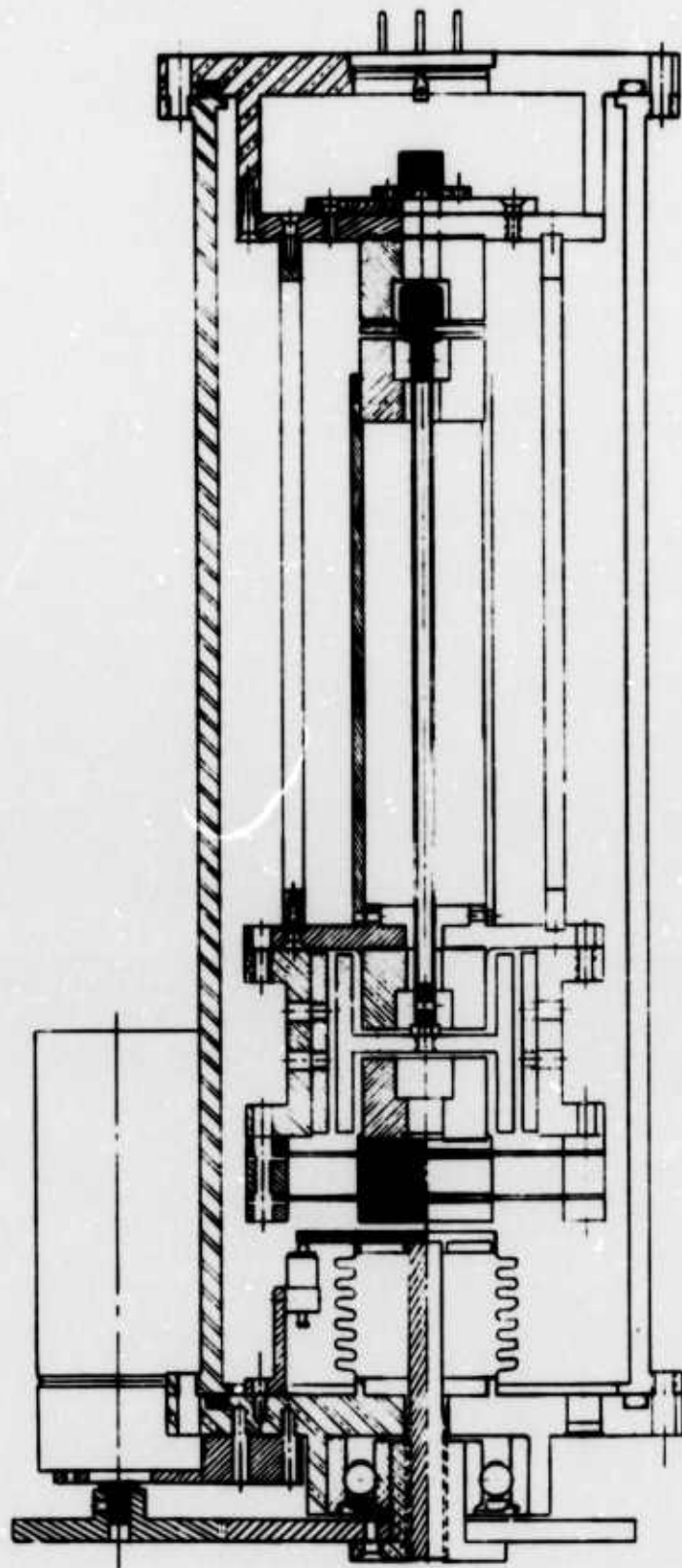

TILT METER

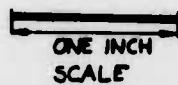
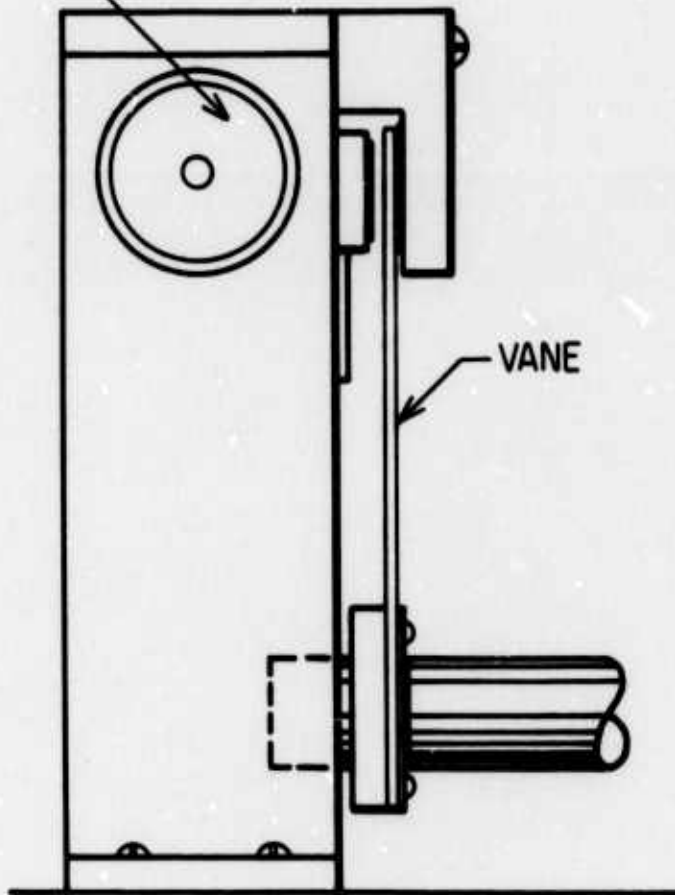
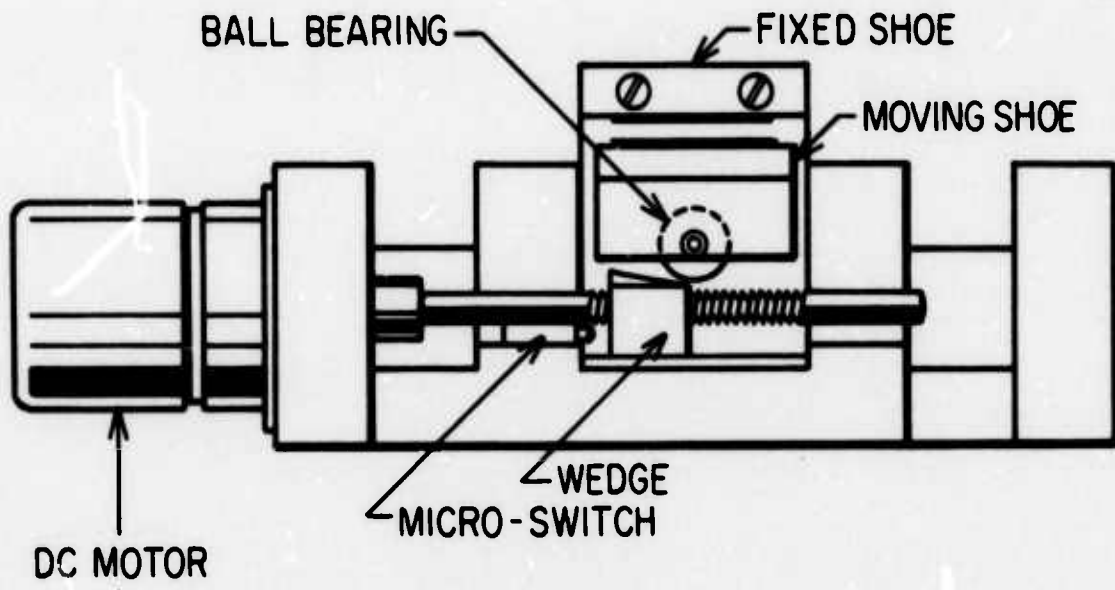

Figure 7



GIMBAL BRAKE

Figure 8

Figure 9 shows the disc brakes, the gimbals, the accelerometer, and the tiltmeter. The cup on the end of each motor provides electrical filtering of the power to the motors. This was necessary, because the logic circuits were badly disturbed by noise induced by the running motors. The power circuits for motor control are contained on cards mounted adjacent to each motor. The accelerometer is mounted on an inner ring which provides for fine leveling independent of the tilt-meter. A motor on top of the accelerometer is coupled to the gravimeter capacitor plates to zero it after the capsule is deployed. The gimbal unlocking and locking is repeatable to .1 of full scale, or $\pm 3 \times 10^{-4}$ radians.

While the gimbal clamps provide a rigid connection, they are too small to withstand the extreme forces exerted during the handling of the capsule in transit from the laboratory to the ship. A solenoid lock was installed as shown in Figure 10. The moveable shaft of the solenoid fits into the hole in a bracket on the bottom of the accelerometer can. Upon command, the solenoid is actuated, freeing the system to level when the disc brakes are unclamped. Positive action of the solenoid is indicated by a microswitch and mechanical lock arrangement that holds the solenoid shaft retracted once it has been actuated. The unlocking command is usually given just prior to the capsule launch.

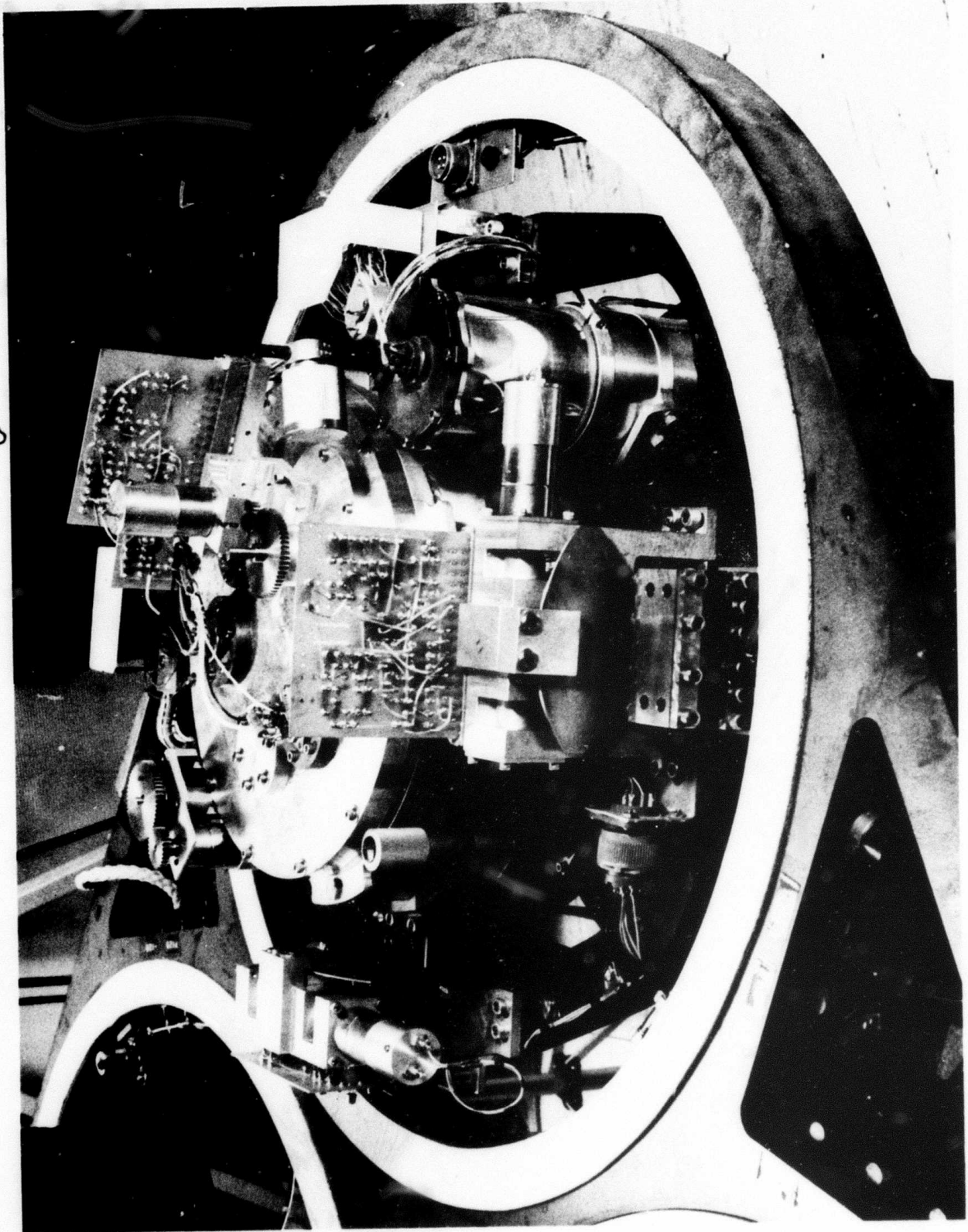

Figure 9

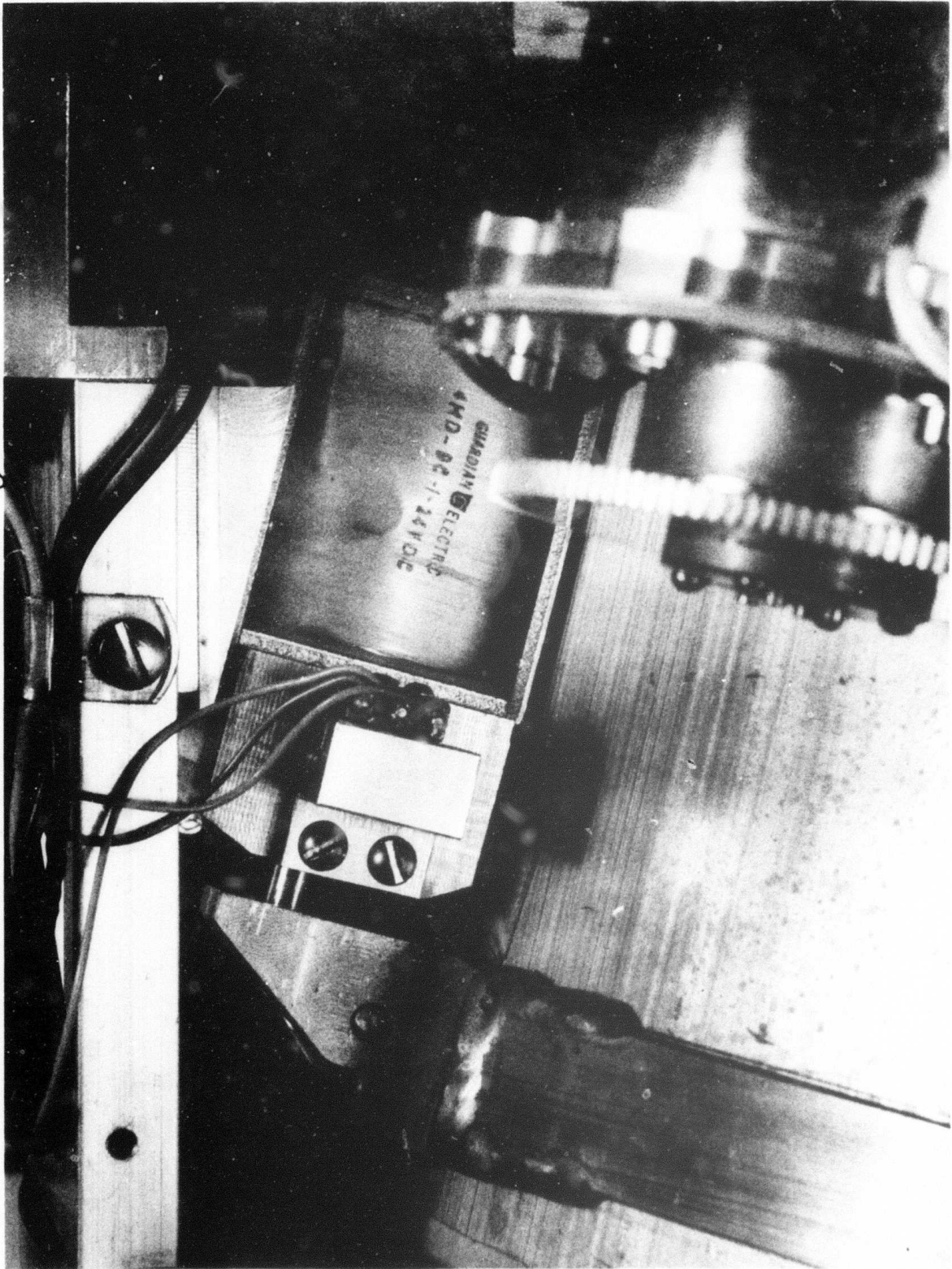

Figure 10

Electronics Card Cage and Tape Recorder

The electronics card cage is simply a housing for the analog and digital electronics for the capsule. Figure 11 shows this unit in its extended position. All input connections are unpluggable so that the entire unit can be easily removed. It is mounted on rubber shock mounts to protect the electronics from the severe ship's vibration. The cards use Elco-Varicon connectors. We have found that the connectors may open up, providing no connection after repeated insertions and withdrawals. These will not be used in the future. The logic cards are all wire-wrapped. This allows for maximum design change flexibility and is an extremely reliable interconnection system. The analog cards are constructed using stamped in posts connected with teflon tubing covered bus wire. They are cleaned and sealed with clear Krylon. No failures have occurred due to this method of circuit assembly.

C. Electronics

The capsule electronics system is described by the block diagram of Figure 12. The three basic functions are: 1) the sensors and analog sensor electronics, 2) the control and diagnostics electronics, and 3) the data recording electronics. These will be described in detail in the following sections.

Several important design attitudes were adopted for this system. First, complementary MOS (CMOS) logic was used throughout. Digital rather than analog circuits were used whenever possible. We have found that digital circuitry is easier to design, more reliable, and easier to repair than comparable analog circuits.

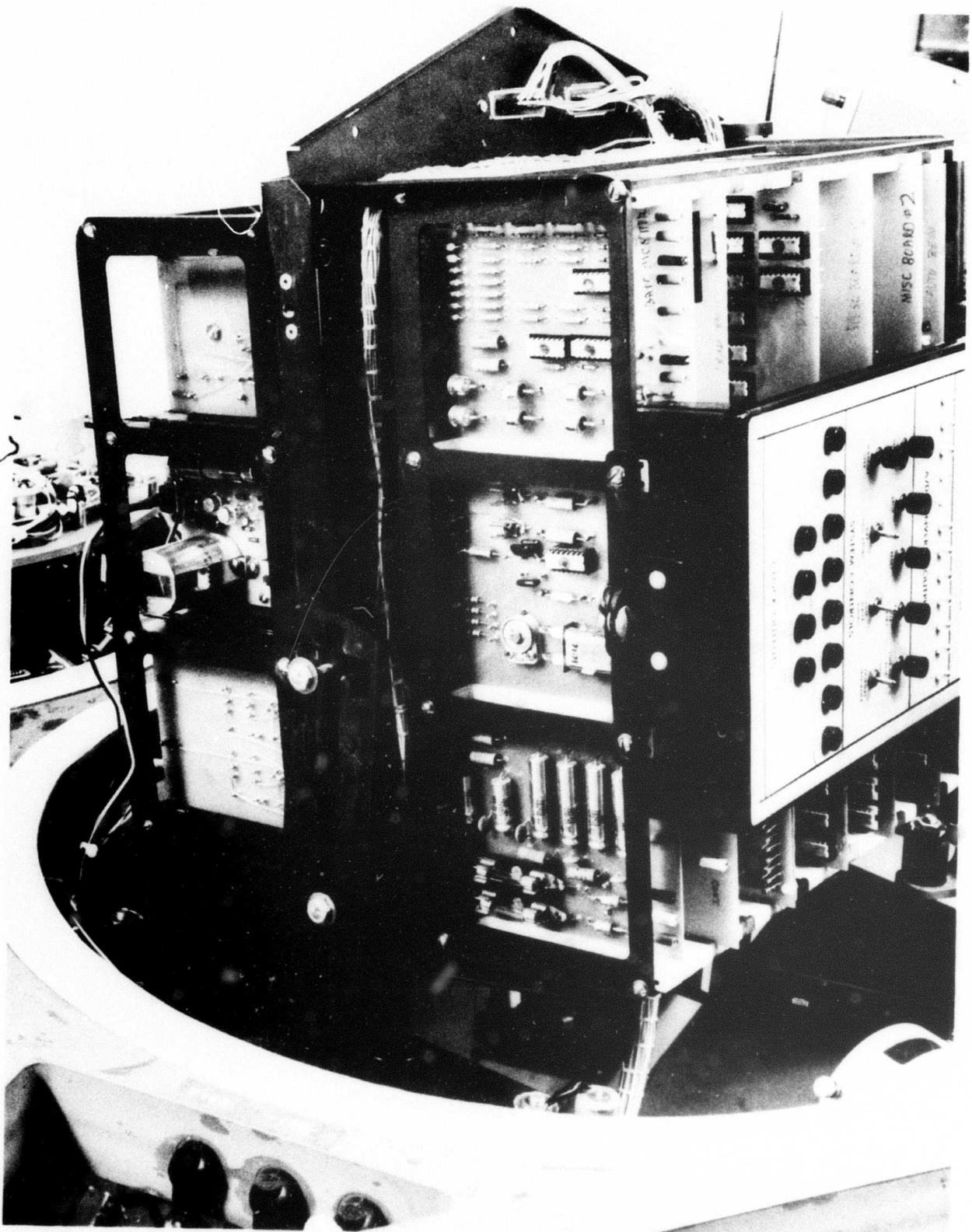

Figure 11

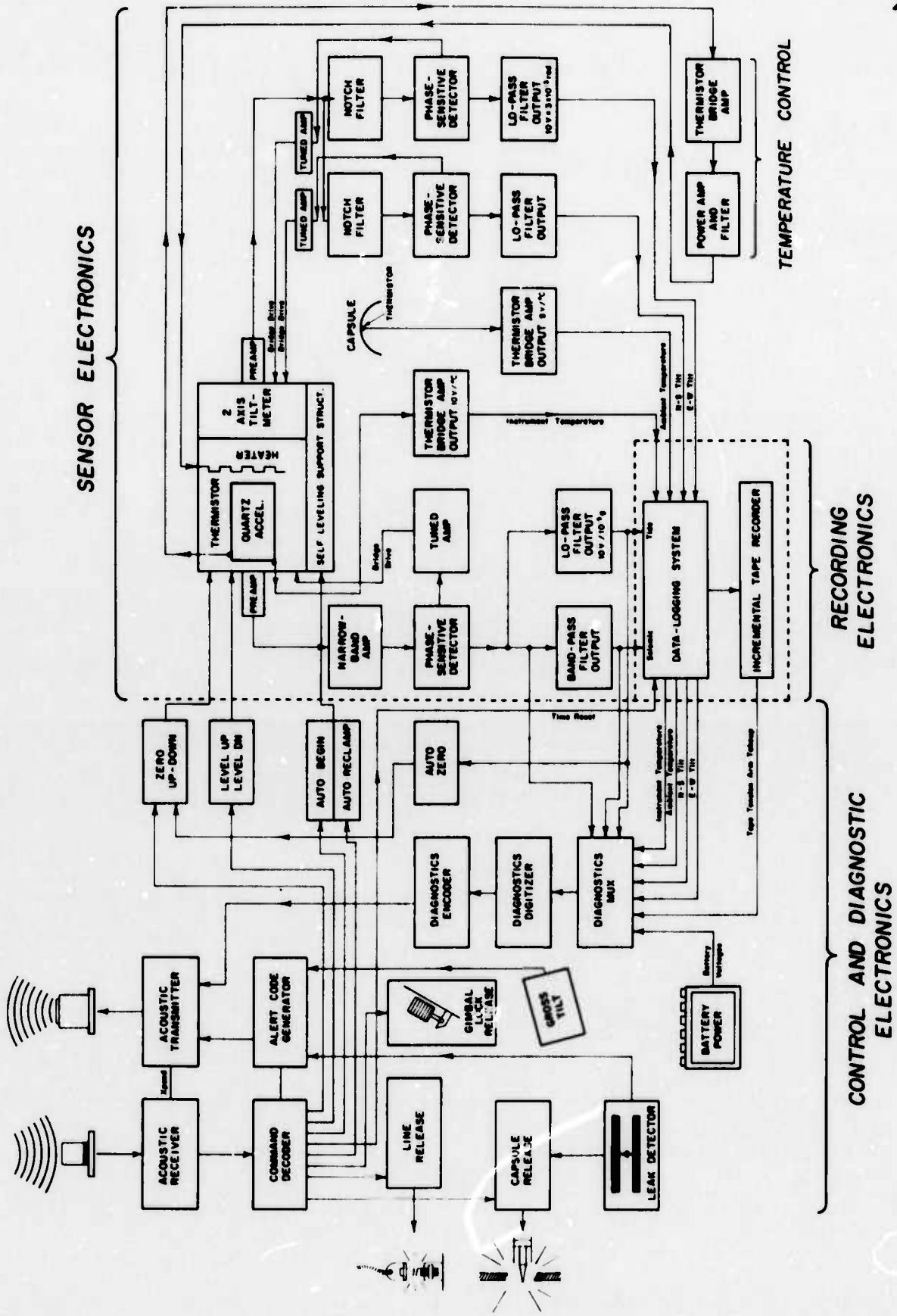

Figure 12

Another important philosophy is to keep the number of different electronics components to a minimum. For most applications requiring discrete transistors, the 2N2270 is the NPN and 2N3251 is the PNP. In addition, the electrical common is floating with respect to the pressure housing. A 10 μ fd capacitor provides an AC current path. This is extremely important, for if a battery lead exposed to the water should leak, a hole in the pressure housing could be formed by electrolysis in a matter of days. Another important design philosophy is that every component crucial to capsule recovery should have a backup. The acoustic release has a timer backup, for example. Thus, in order to lose a capsule, two failures or mistakes must be made. Elaborate checkout procedures have been devised to lessen the chance of human error.

Analog Sensor Electronics

The quartz accelerometer output is generated by a capacitance bridge that senses the position of the moving mass. Figure 13 shows the circuit used. The transformer provides two equal AC voltages 180° out of phase. The capacitance between the top plate and the moving mass is compared to the capacitance between the bottom plate and the moving mass. The output voltage is proportional to the distance off-center and has the phase of the nearest plate. It is amplified by a preamplifier built into the accelerometer, then further amplified and processed by a phase-sensitive detector, which has a DC output which varies between ± 10 volts. The circuits are shown in Figures 14 to 17. The preamplifier has a gain of 10, the gravimeter amplifier has a switchable gain of 10, 100, and 1000. The maximum gain is determined by how fine the remote zeroing can be done and is limited to an equivalent acceleration of $\pm 1.4 \times 10^{-5}$ g. The mixer converts the AC carrier signal into a DC signal

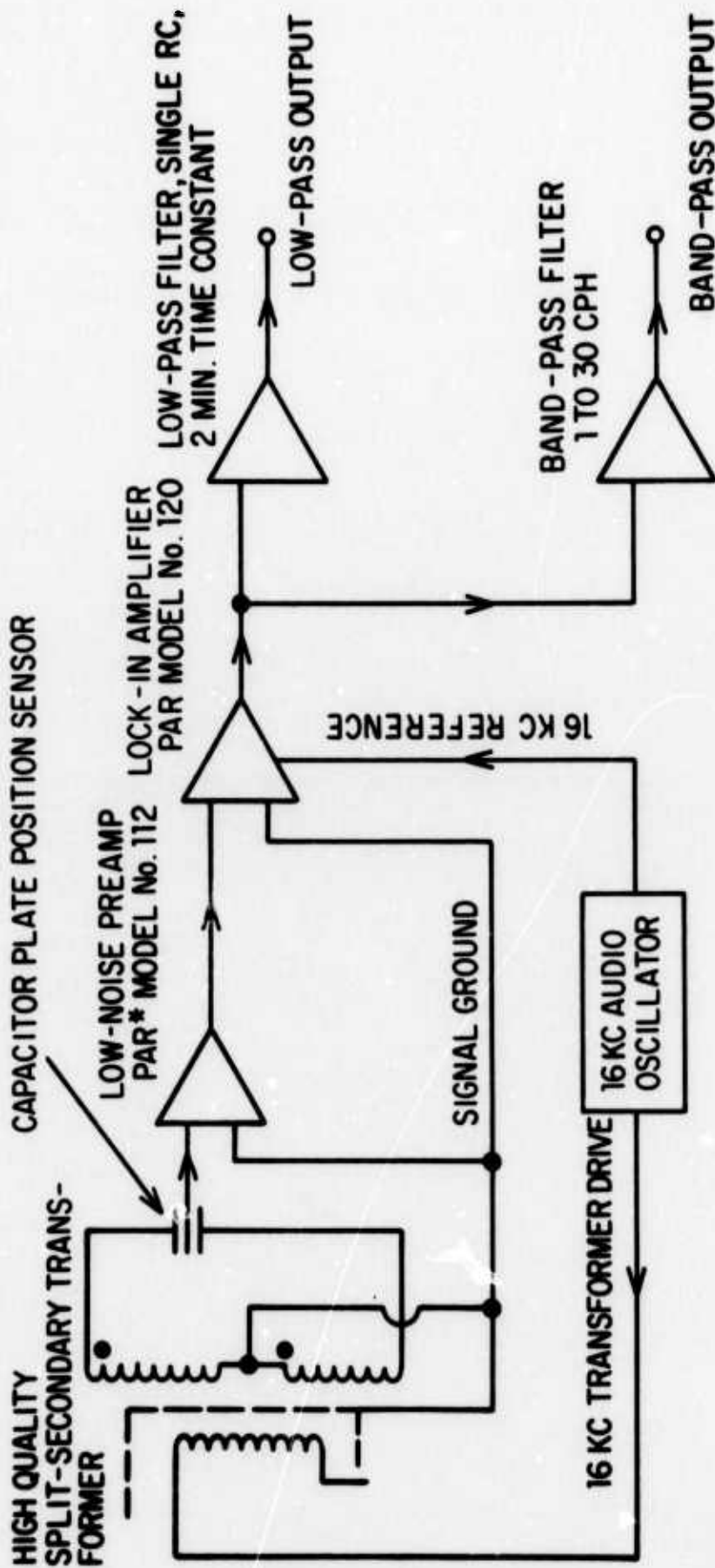
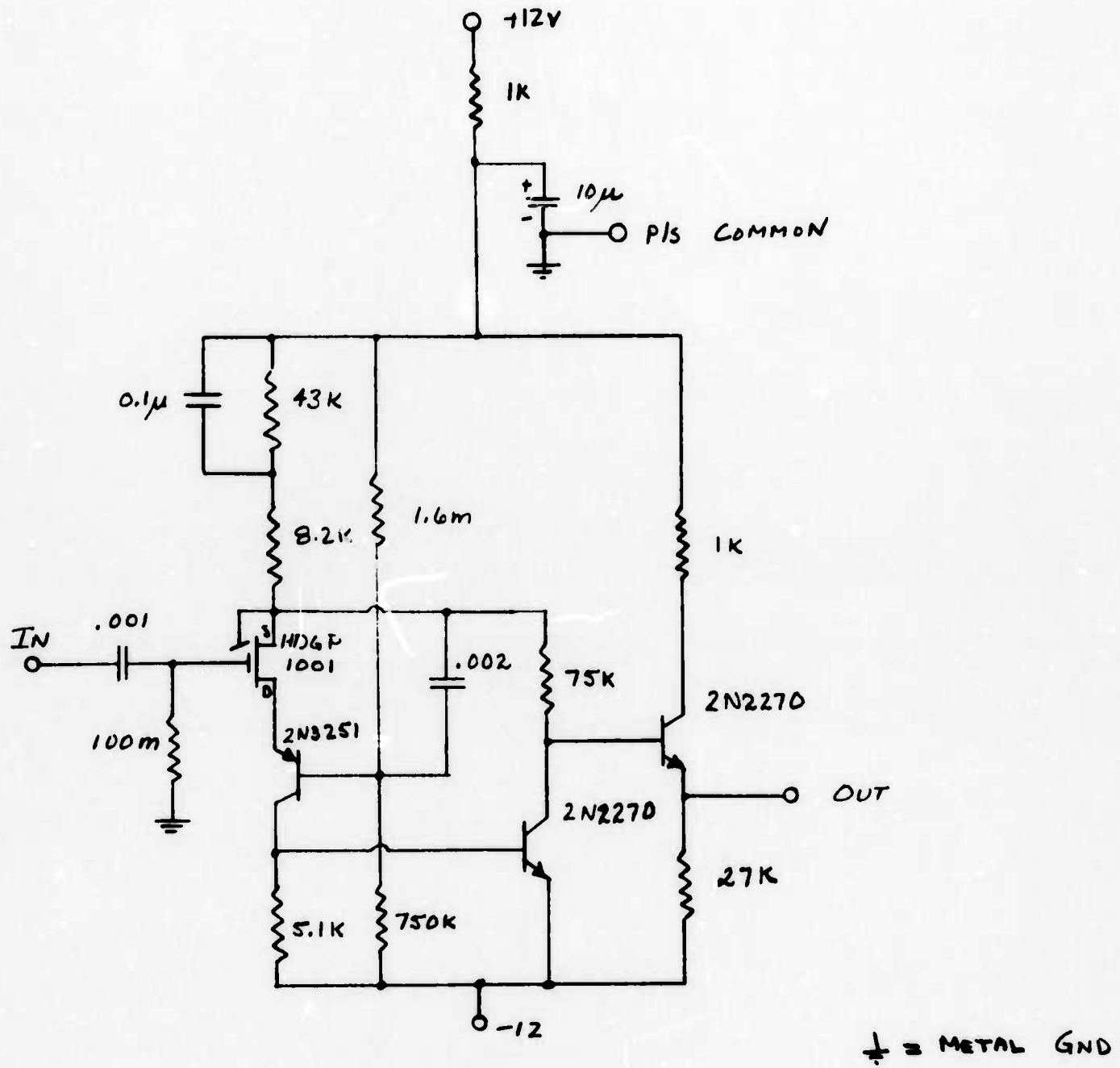

Figure 13



PREAMPLIFIER

10-29-70 SLH

Figure 14

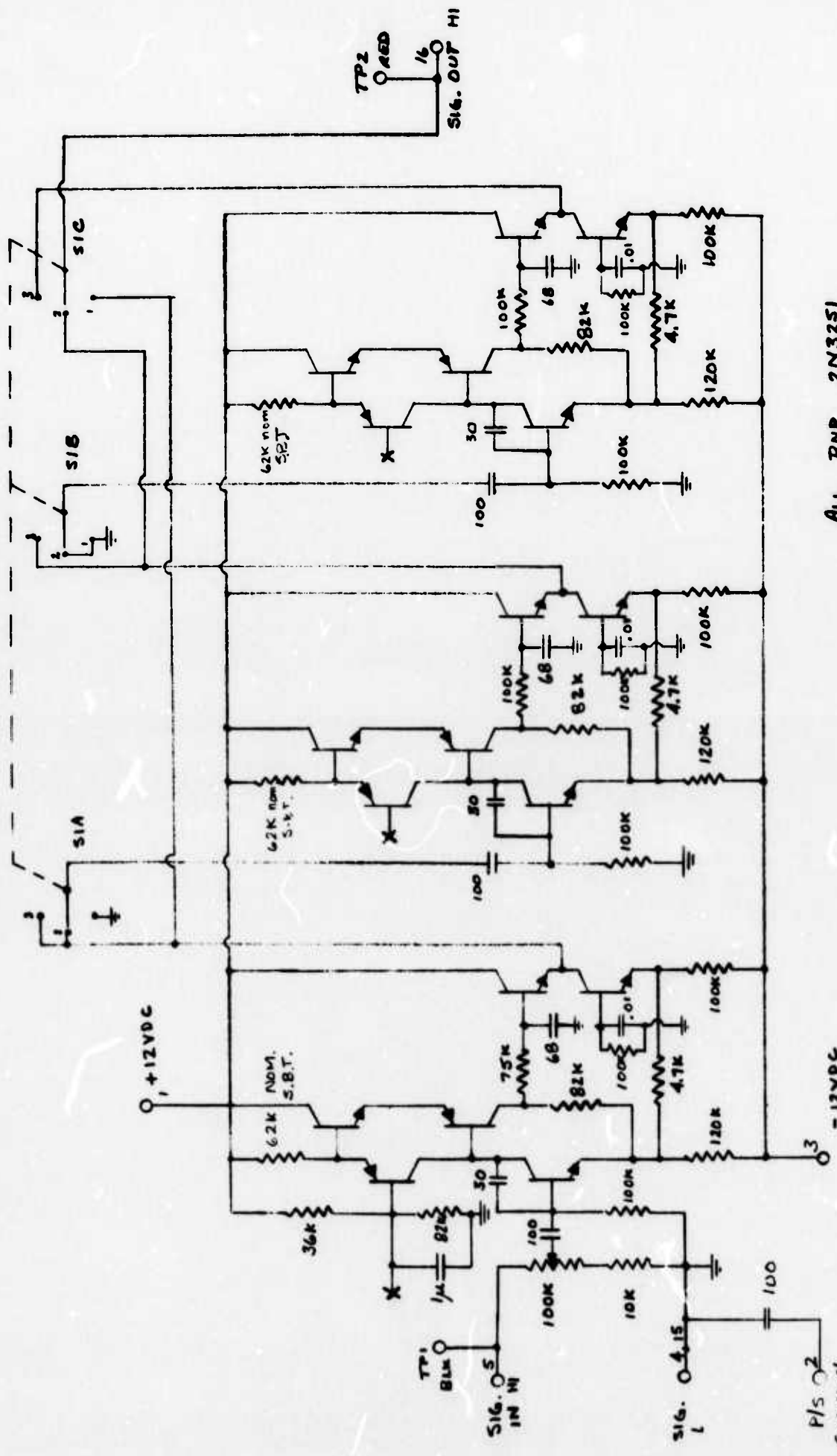

ALL PNP 2N3251
 ALL NPN 2N2270
 ⊥ = COPPER CLAD

GRAVIMER AMPLIFIER
 FINAL 9-2-71 S.L.W

Figure 15

Handwritten scribbles

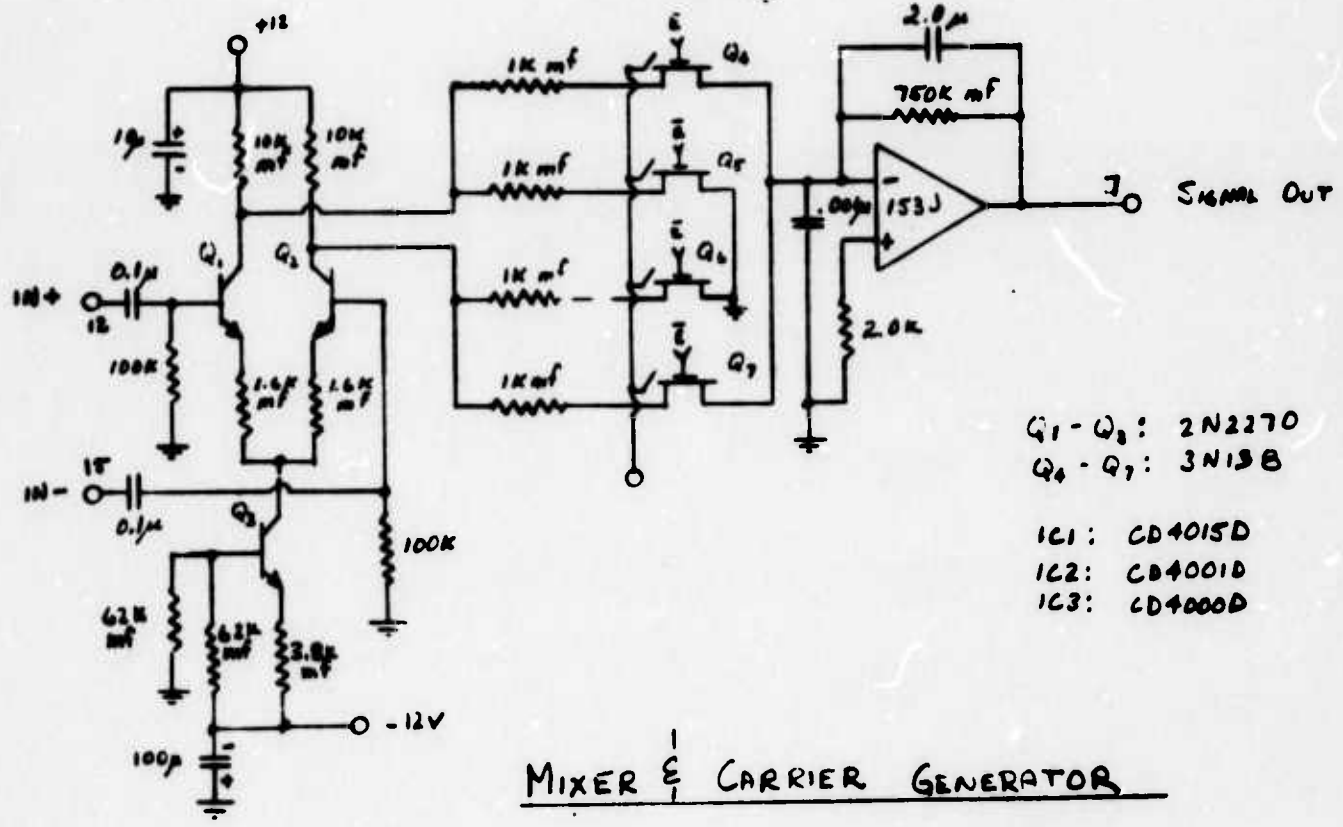
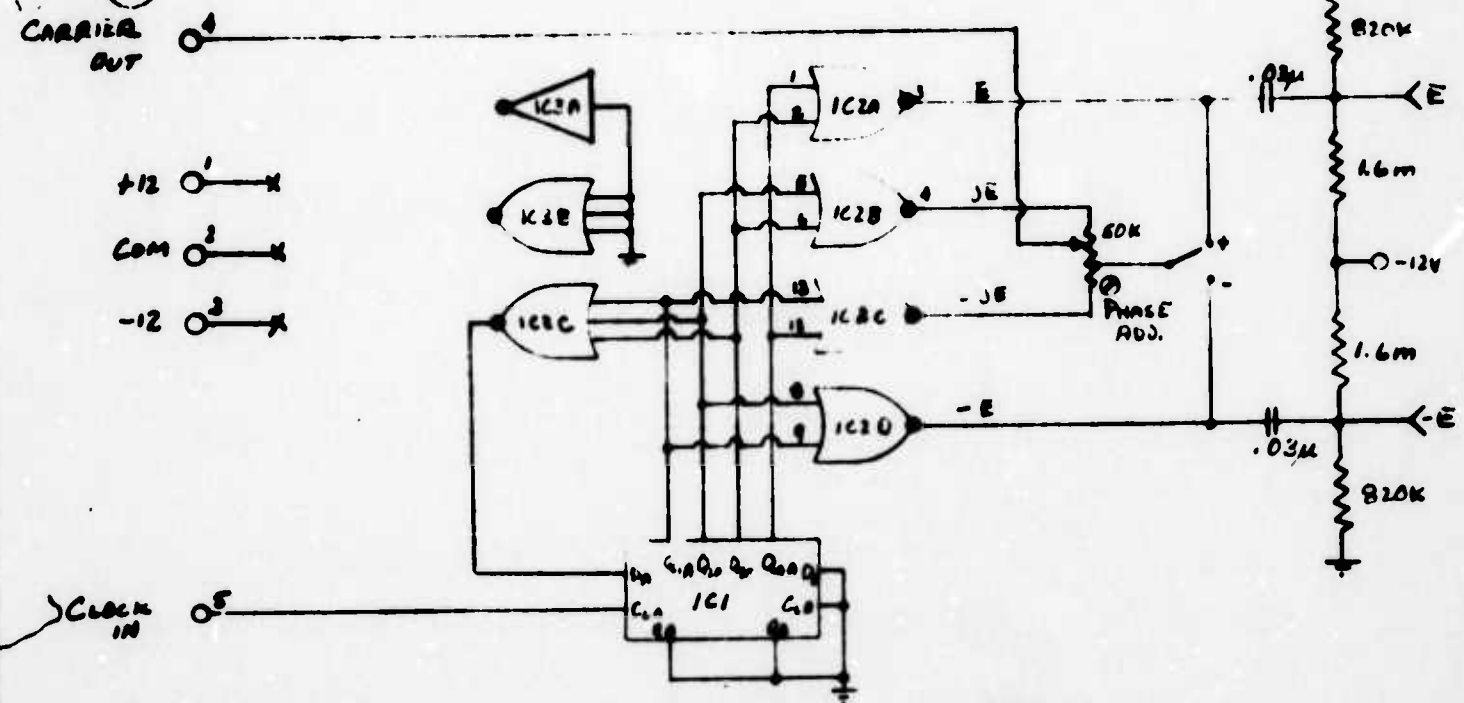

- Q1 - Q2: 2N2270
- Q4 - Q7: 3N138
- IC1: CD4015D
- IC2: CD4001B
- IC3: CD4000D

MIXER & CARRIER GENERATOR

1-6-71 SLW

Figure 16

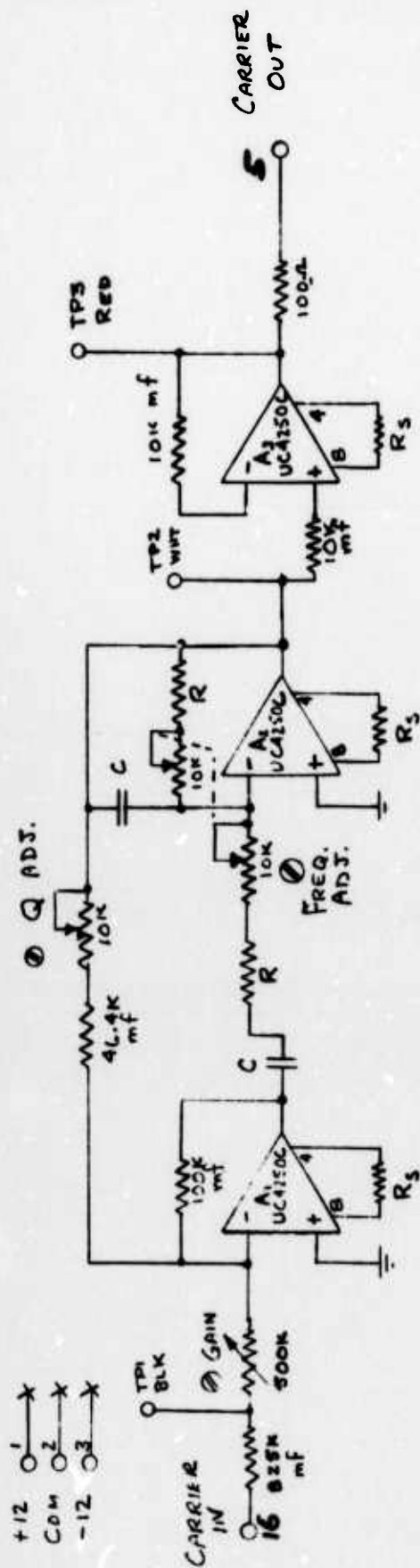

+12 1 X
COM 2 X
-12 3 X

CARRIER IN 16
8.25M mf
GAIN
500K
TP1 BLK

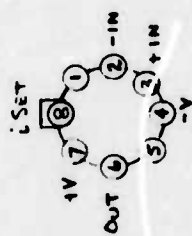

UC4150C

f_0	R (m.f.)	C (mca)	R_s
1024 HZ	42.2 K	3300 pf	1.5 meg
4096 HZ	34.8 K	1000 pf	1.5 meg
16384 HZ	38.3 K	220 pf	510 K

TUNED AMPLIFIER
2-14-71 SLW

Figure 17

that is proportional to the amplitude and cosine of the difference between the reference and signal phases. The mixer also generates the bridge drive frequency which is filtered by the tuned amplifier to produce a reasonably good sine wave. The bridge drive transformer is a shielded bifilar wound toroid produced by J.M.Harder of San Diego. The bifilar windings are necessary to provide precise phase balance of the two secondary windings. The mixer output is related to acceleration by

$$V_n = K\Delta g/g$$

K is found by tilting the instrument and using $\Delta g/g = \cos \theta$ where θ is the angle from the vertical. The acceleration indicated by a steady displacement of the mass by x is $\Delta g = \omega_o^2 x$. Now $V_n = K\omega_o^2 x/g$. For simple harmonic ground displacements,

$$X = \frac{-\frac{\omega^2}{\omega_o^2} X_g + \frac{2g_o X_g}{R_e \omega^2}}{1 - \frac{\omega^2}{\omega_o^2} - \frac{i\omega}{\omega_o Q}}$$

So, substituting for X ,

$$V_M = -\frac{K}{g_o} \frac{(\omega^2 X_g - \frac{2g_o}{R_e} X_g)}{(1 - \frac{\omega^2}{\omega_o^2} - \frac{i\omega}{\omega_o Q})}$$

The $2g_o/R_e$ term is from the static displacement in the gradient of the earth's gravitational field. From the tilt calibration, $R = 7.1 \times 10^{+5}$. For $\omega \ll \omega_o$ and $g_o = 9.78 \text{ m/sec}^2$, then

$$V_M = -\frac{7.1 \times 10^{+5}}{g_o} \omega^2 X_g = -7.3 \times 10^{+4} \omega^2 X_g$$

For X_g expressed in microns, and $\omega = \frac{2\pi}{T}$

$$V_m = - \frac{2.88 X_g}{T^2} .$$

The filter circuits are shown in Figures 18 and 19. Figure 20 is the measured filter responses. The curve of Figure 21 is a plot of the magnification of the seismic filter output computed using the above equation and the measured seismic filter response. A check on the calibration could be performed by computing the theoretical earth tides and comparing the measured earth tides. This would provide a calibration to a few percent accuracy.

The tilt-meter circuits are identical to the accelerometer circuits except that notch filters are substituted for the AC amplifier. Since the N-S and E-W signal frequencies are mixed on the tilt-meter preamp output, the notch filter for the N-S channel eliminates the E-W signal and the E-W filter eliminates the N-S signal. By using a notch filter rather than tuned amplifiers, amplitude and phase shifts of the signals due to variations in components are reduced, as the signal frequency is then far from a circuit resonance. No special filtering is provided for the tilt-meters, as they are operated at low gain so their noise level is low.

The noise level of the accelerometer electronics can be measured by disconnecting the capacitance bridge drive. Using this method, the noise level was found to be 10mv peak-to-peak at the seismic filter output. This corresponds to two least counts on the analog-to-digital converter. This is somewhat high and could be reduced by redesigning the preamplifier. A low noise preamplifier sold by Princeton Applied Research has approximately

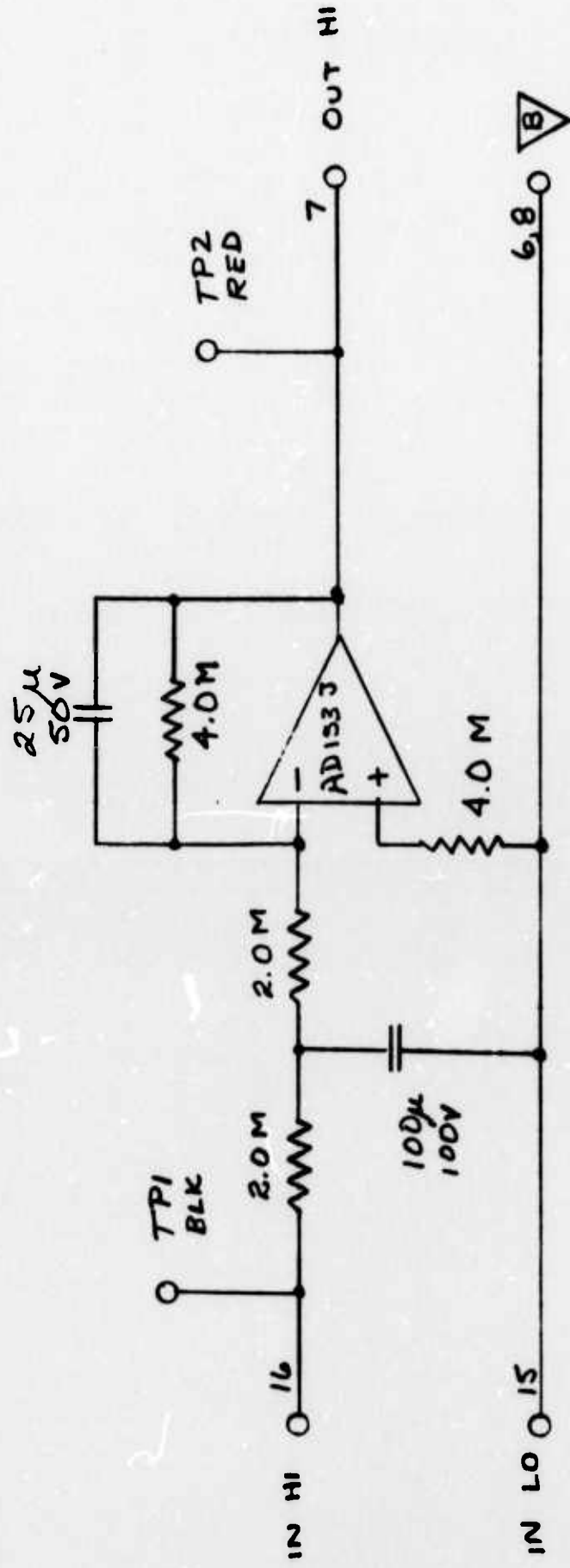

+12V 1 X
 COM 2 X
 -12V 3 X

ALL RESISTORS 1% PYRO.
 ALL CAPS POLYCARB.

TIDE FILTER

B-16-71 SLW

Figure 18

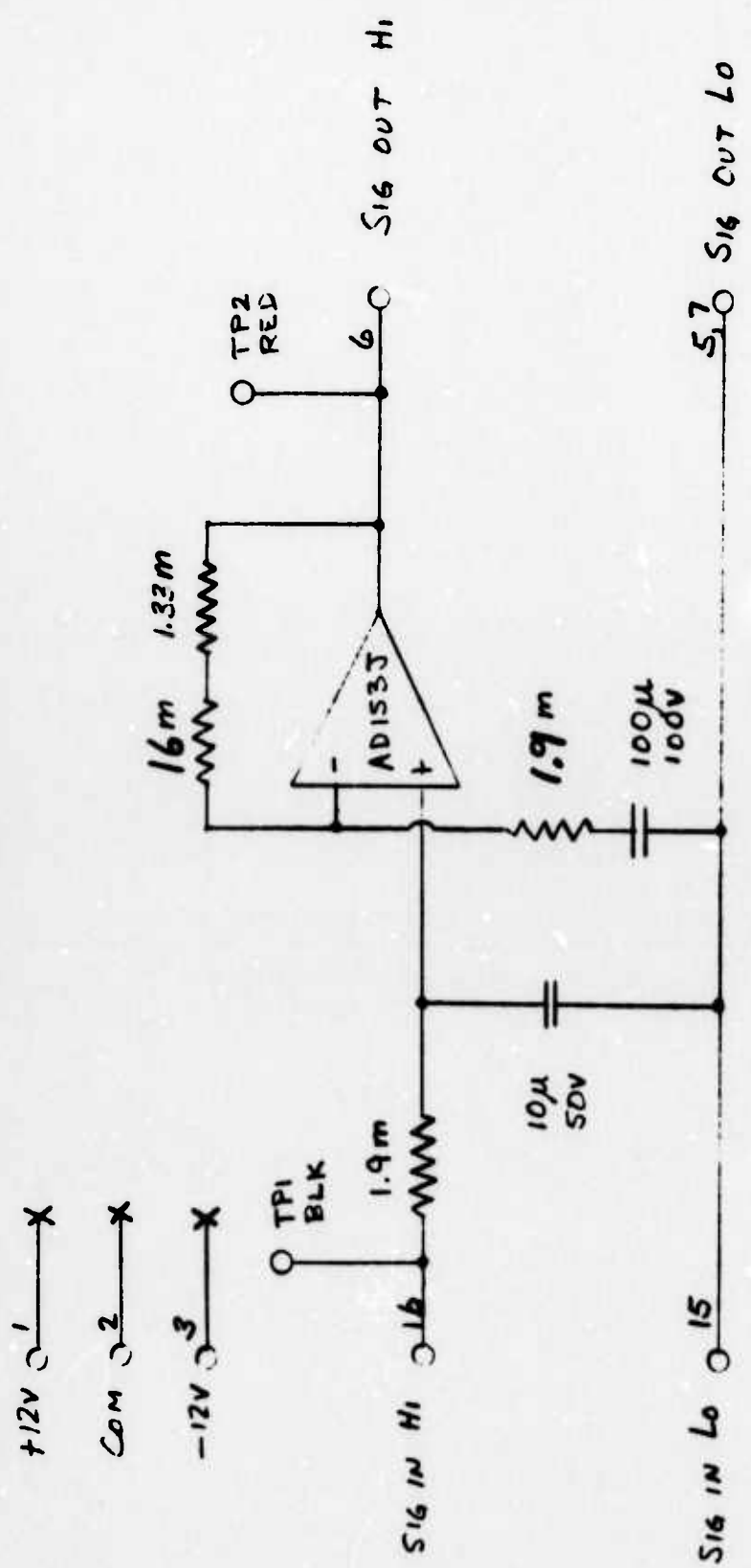

PHILTRE SECTION (ONE OF TWO)

8-17-71 SLW
6-7-73 W.P.

Figure 19

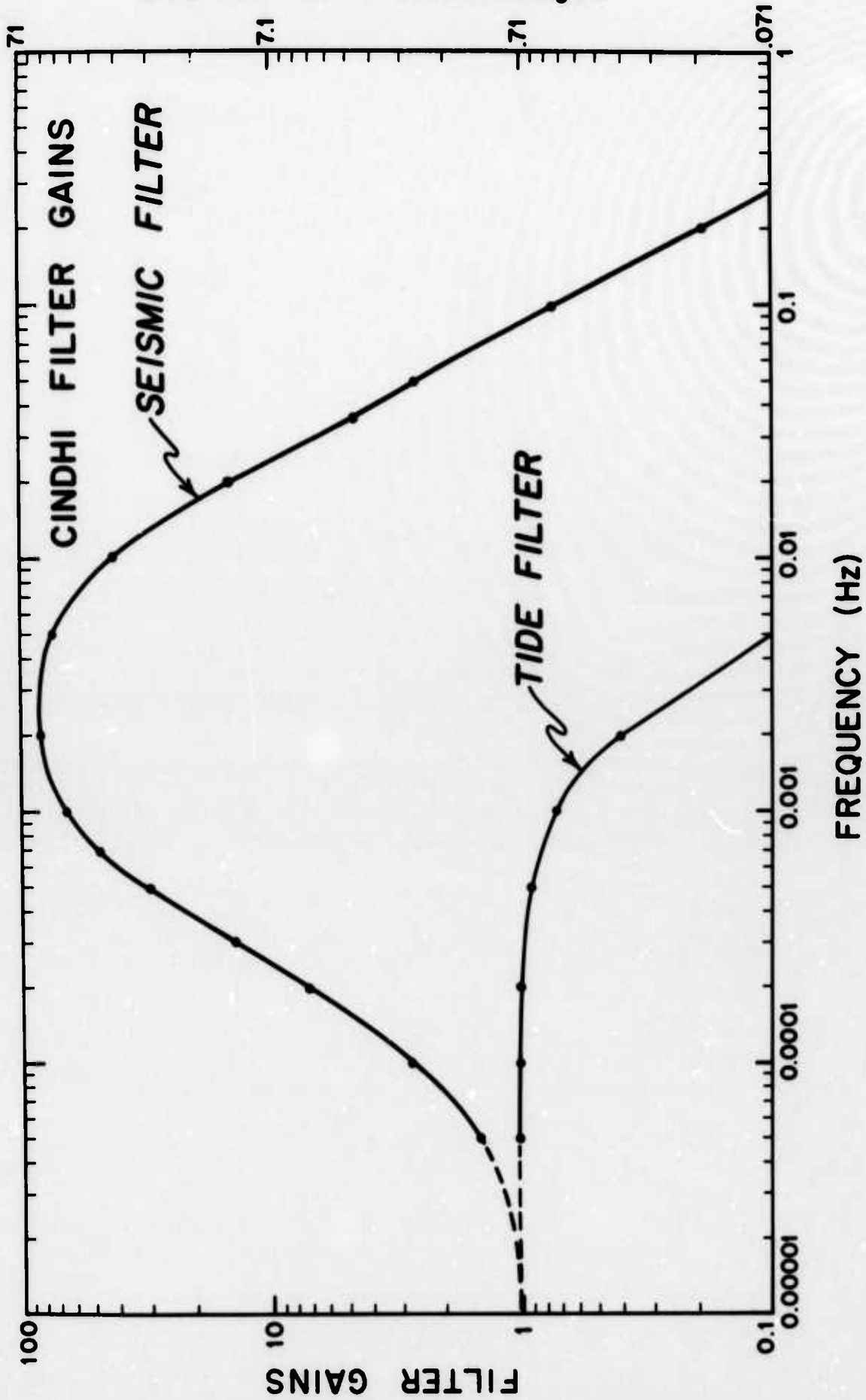

Figure 20

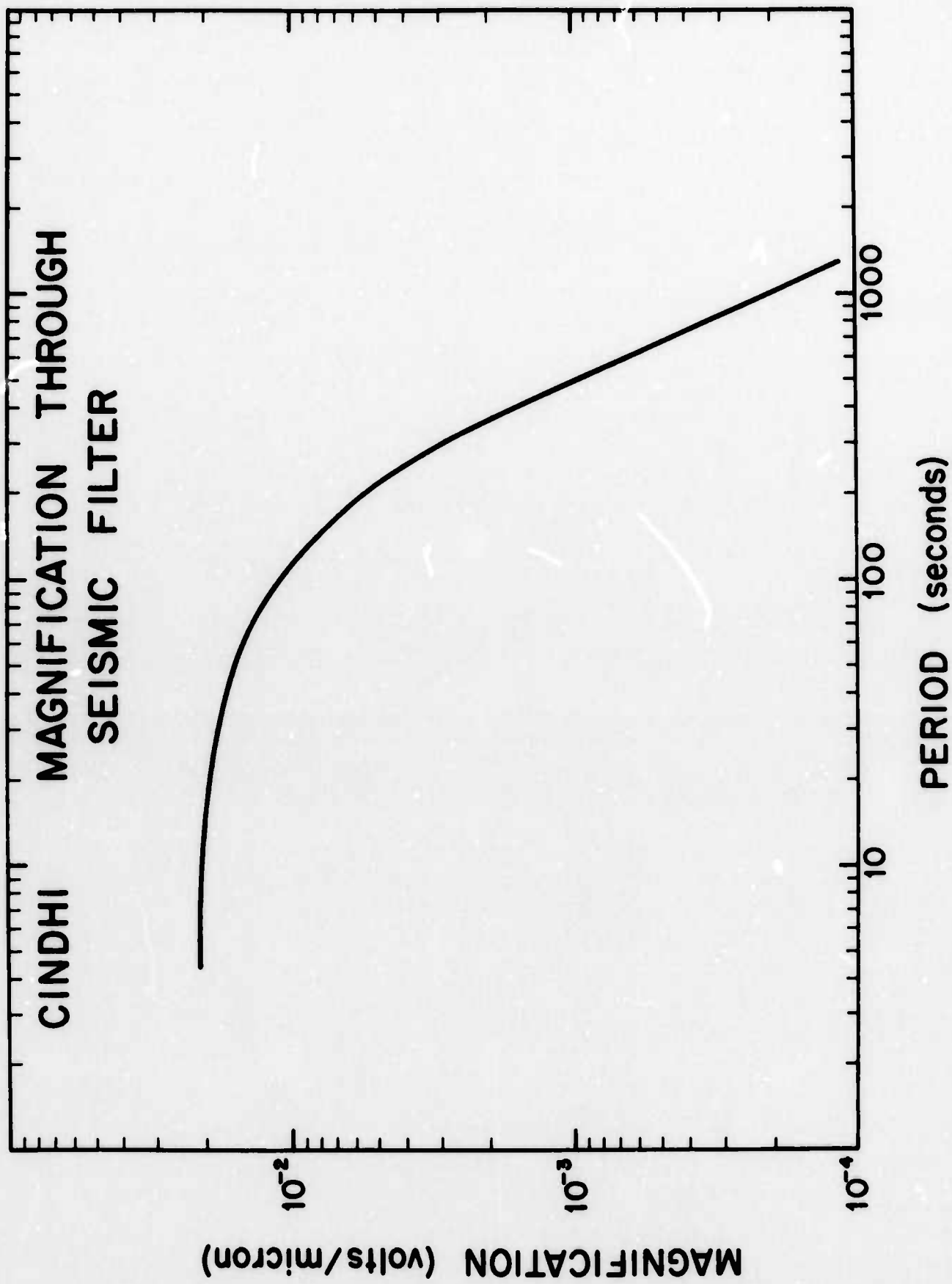

Figure 21

10 times less noise in the band of interest, but requires higher power.

Another potential source of noise is the accelerometer temperature regulation. The temperature dependence of the accelerometer is $\Delta g/g/^\circ C = 10^{-4}$. Thus a 1 microdegree temperature variation would induce a 10^{-10} g signal. Fortunately, the ocean bottom temperature varies by less than 10 millidegrees, providing a fairly constant temperature environment for the temperature regulator to start with. Laboratory measurements showed that the regulator reduced ambient temperature variations by a factor of 500. This means a 20 microdegree variation could be expected. The gravimeter temperature monitor circuit never did produce useable results. Even though the accelerometer was temperature regulated, the regulation point varied enough with ambient temperature so that it was difficult to get the monitor on scale. Finally, on the last deployment, the gain was turned down to $\pm 1^\circ C$ full scale so that $5 \times 10^{-4}^\circ C$ could be resolved. No temperature variations were observed. The noise on the accelerometer output limits temperature variations in the signal bandwidth to less than $2 \times 10^{-4}^\circ C$, so the temperature monitor was not much help. The output noise level will be discussed further when data is presented.

Motor Control Electronics

The function of the motor control electronics is to run the brake control or leveling motors in either direction under control of input logic levels. For the gimbal clamp motors, logic level outputs are needed to indicate that the clamp or unclamp function is complete. The motor must clamp the gimbals tightly, but not so tight that the motor cannot unclamp them. The braking force exerted by the brake in the clamped position is determined automatically as follows. Before the moving shoe contacts the

fixed shoe via the vane, the amount of torque required to move the wedge along is quite low. The motor current under these conditions is about 5 milliamps. As soon as the moving shoe contacts the vane the force required to move the wedge builds up rapidly and consequently the motor torque builds up rapidly. This is reflected in a rapid increase in motor current as the motor approaches a stall condition. The electronic driving circuit monitors the motor current and is set to shut off the motor drive current when it has reached a value of approximately 30 milliamps. The electronics required to operate this system for both the clamp and unclamp operations and to do so reliably and with a minimum consumption of power is shown in Figure 21. The unclamp condition is simply controlled by the closing of a magnetic reed relay indicated between pins 6 and 7 of Figure 22. An identical circuit is used to clamp and unclamp the tilt-meter. The level and zero motors do not use the high motor current indication feature.

The clamp and unclamp functions are controlled by a logic card in the digital card cage. The AUTO BEGIN cycle, which is initiated by acoustic command, consists of unclamping the gimbals, reclamping them, and unclamping the tilt-meter. The AUTO RECLAMP cycle, also initiated by acoustic command, clamps the gimbals (in case they were left unclamped for any reason) and then clamps the tilt-meter. The capsule is then ready to be released and recovered.

It was not known whether the accelerometer would drift off-scale during a one month deployment, so an automatic accelerometer zeroing circuit was constructed. The circuit senses the TIDE filter output and if it is greater than 8 volts for one year, it produces Zero Down commands, which consist of one second of motor run time, until the

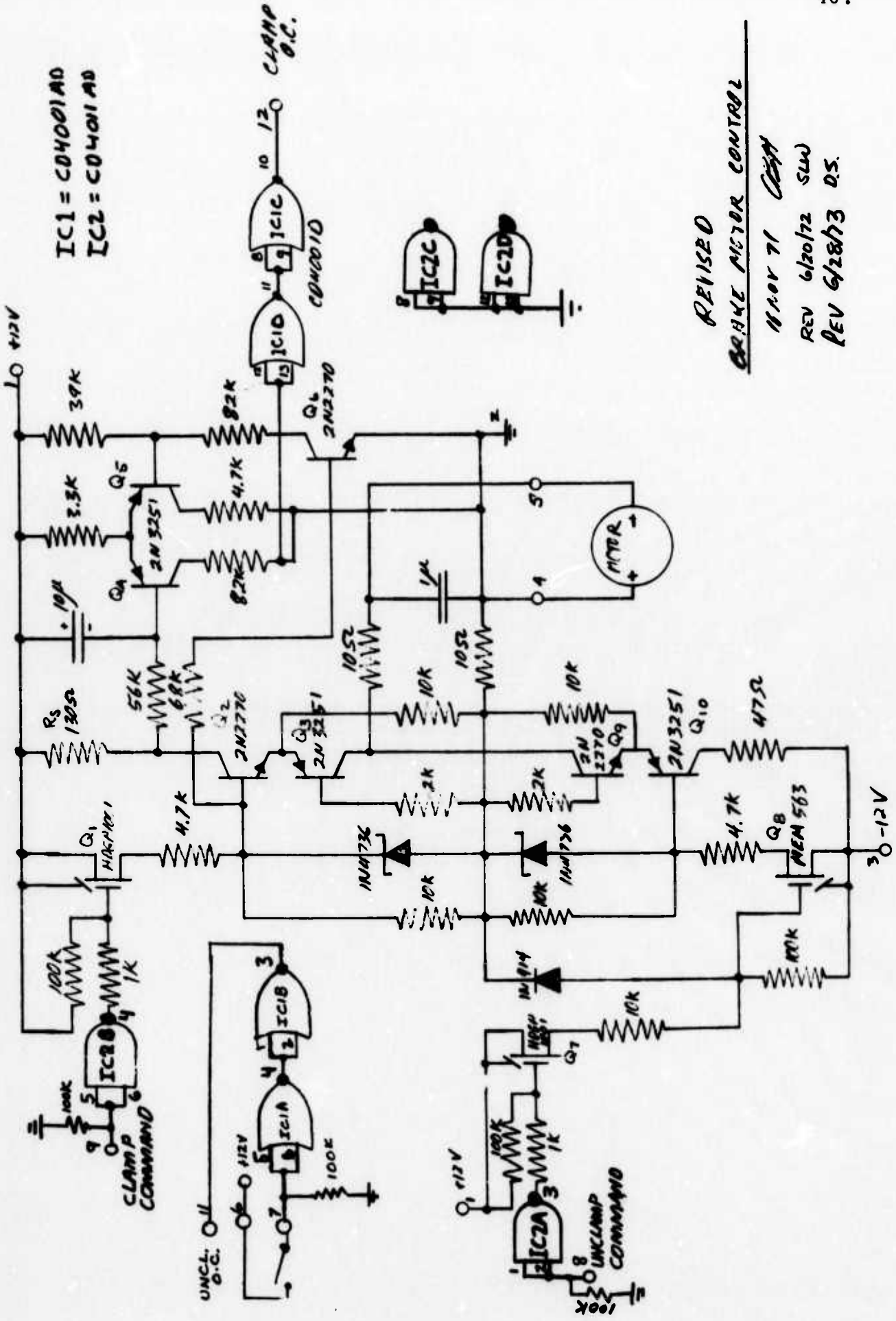

Figure 22

output voltage is less than -1.5V. If the TIDE filter output is less than -8 volts for one hour, it gives Zero Up commands until the output voltage is greater than 1.5 volts. The TIDE filter has a very slow response, so zero down command is given only once every 32 seconds. A diagnostic cycle is initiated automatically after every zero or level command. Figure 23 shows the circuit used. The operational amplifiers perform as threshold detectors with the required hysteresis. C1 provides the one hour time delay. Q_{13} of C1 is high for 4096 seconds, then low for 4096 seconds.

In actual practice, this feature proved most useful for performing the initial zeroing of the accelerometer after it was deployed. Further zeroing proved unnecessary. For the last deep ocean drop, it took about 30 hours for the automatic zero to zero the instrument. An improvement to this circuit would be to go to a longer motor run time after a number of automatic zero commands, then switch to a shorter time after the first zero crossing. One problem with the accelerometer zeroing system has been that the shortest practical motor run time (one second) produces too large a signal offset. This means that the accelerometer electronics gain must be reduced to that the electronics outputs remain on scale through enough zero cycles to ensure that it will not overshoot in the opposite direction.

Acoustic Command System

The capsule acoustic command system purchased from EDO Corp. consists of an acoustic receiver tuned at 9.25KHz, an acoustic transmitter for 13.5KHz or 15.5KHz, which can transmit in a continuous or pulsed mode, and decoder circuitry which is capable of decoding 10 commands. The system also functions as a transponder for ship-to-capsule ranging. A complementary surface unit encodes the commands and transmits them to the capsule. The other portion of the capsule command system was designed and constructed by

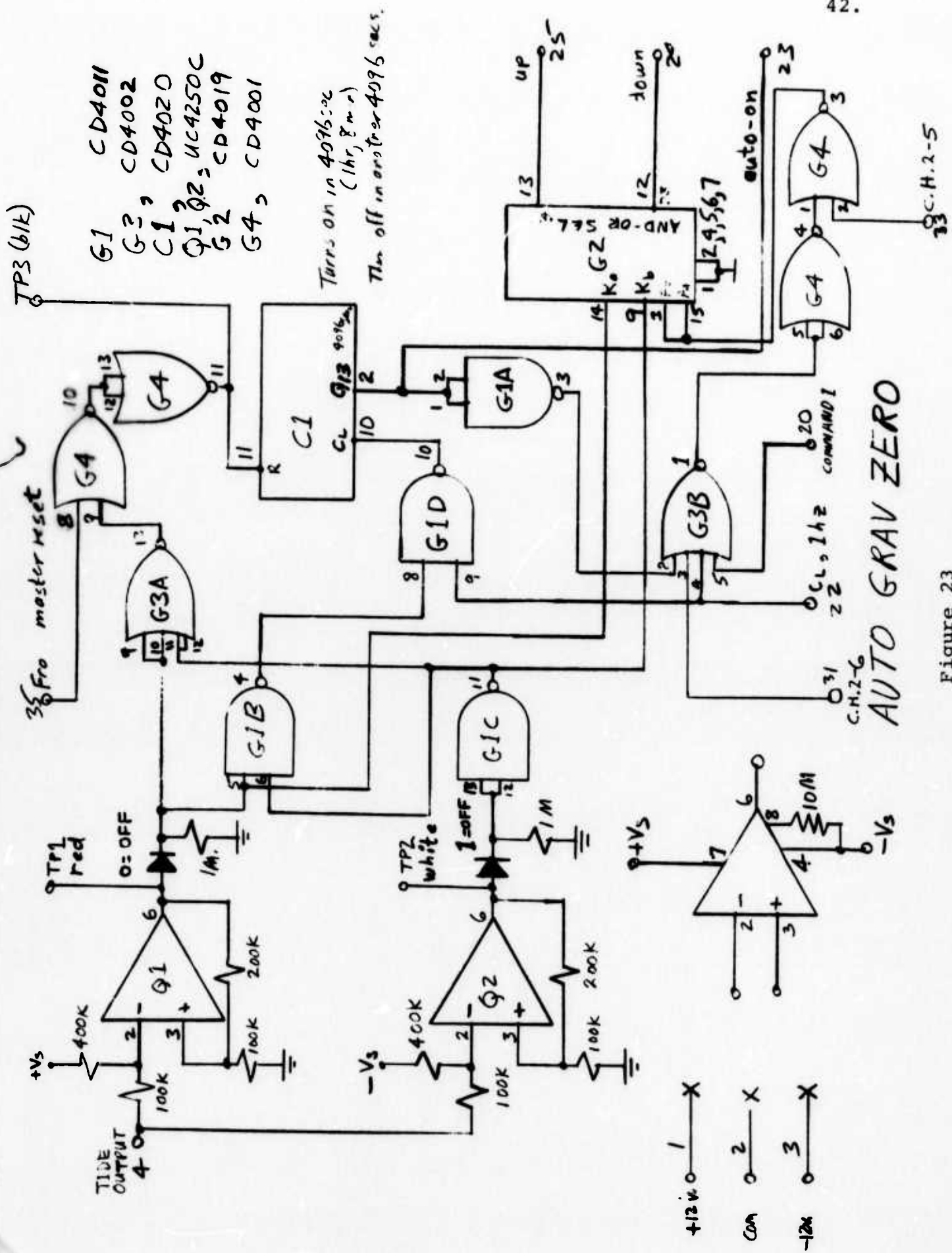

Figure 23

AUTO GRAV ZERO

workers on this project. It converts contact closures provided by the EDO unit to useful control and timing logic for the capsule components. These functions are indicated in Figure 12.

Our experience with the EDO command system proved largely unsatisfactory. The command receiver is an out-dated design and worked poorly. The command decoders used discrete component one-shots of several different designs. Timing provided by these units was variable. The continuous mode operation for data telemetry was not ideal because the 15.5KHz transmit mode took a second or two to begin after it was initiated. Thus it was impossible to transmit pulses at that frequency. The continuous mode diagnostic data transmission worked quite well, however. During the last deep ocean deployment, the acoustic system failed due to a leak in the receiver hydrophone, so the capsule was released on its backup timer.

In spite of the poor acoustic equipment design, there are several advantages to the EDO method of encoding commands. This method and our experience with a well-designed acoustic system is worth further discussion. Basically, the command consists of a 30 millisecond pulse of the 9.25KHz carrier frequency, a one second delay, and then a burst of 2msec pulses of the carrier. The pulse rate of the burst determines the command to be initiated. These frequencies vary between 98 and 200 Hz. If one of the commands should be initiated during the one second delay time, it is judged to be a false command and no command is accepted. So, not only must the pulse repetition rate be correct, but the dead zone must occur at the correct time. We have never observed a false command using this encoding scheme.

Since this project was discontinued, another project using small ocean bottom seismic capsules has begun. The acoustic system consists of the

EDO surface command unit and a modified transponder manufactured by Sona Tech Corp. of Santa Barbara, California. The unit functions as a transponder and acoustic receiver. It is contained in a separate pressure case with its batteries. The receiver output and an external ping control are connected to the capsule through high pressure connectors and underwater cables so that the receiver output can be decoded into the desired commands and the capsule can initiate transponder pings for the purpose of diagnostics. This system works quite well and the only failure has been a leak past the O-ring in the pressure housing. Commands are reasonably easy to initiate, particularly when the ship is directly over the capsule. As the slant angle increases, commands are less easily accepted, probably due to multipath interference with the bottom. Occasionally one command burst frequency has difficulty being accepted, while others are easily accepted. In spite of this, this command encoding technique has been found to be simple and reliable. It is prudent to design the system to require as few acoustic commands as possible.

Acoustic Diagnostic System

The diagnostic system operates in two modes. First, a system of alert codes which are recognizable by ear indicate commands received, operations completed, and leaks, tilts, or battery power off. These codes are ping patterns and are shown in Table 4. There are 12 equal time intervals during which a ping is either present or absent. The pattern repeats eight times. If more than one alert is appropriate, the pings from both patterns are added and transmitted simultaneously.

The other mode of the diagnostic system is for digital data transmission (see Fig. 12). The EDO subsurface unit transmits continuously at 13.5KHz or 15.5KHz, depending on a frequency control logic level. At

COMMAND	CODE		
	Block 1	Block 2	Block 3
1 SELECT	XX	XX	X XX
2 SELECT	X X	X X	X XX
1-3 RELEASE	XX	X X	X
1-4 UNSTOP GIMBALS	X X	XX	XX X
1-5 AUTO BEGIN CYCLE	XX	XX	XX X
1-6 DIAGNOSTIC SCAN	XX	XX	X
1-7 START LOGGER	XX	X X	XX X
1-8 SLOW DIAGNOSTIC SCAN	XX	X X	X XX
1-9 SEND ALERTS	X	X	X
1-10 MASTER RESET	X X	X X	XX X
2-3 LINE RELEASE	XX	X X	X
2-4 AUTO RECLAMP CYCLE	XX	X X	XX X
2-5 ZERO UP	XX	X X	X
2-6 ZERO DOWN	XX	X X	X XX
2-7 LEVEL UP	X X	XX	X
2-8 LEVEL DOWN	X X	XX	X XX
2-9 DIAGNOSTIC SCAN	XX	XX	X
2-10 SLOW DIAGNOSTIC SCAN	XX	X X	X XX
GROSS TILT	X X	X X	XX X
LEAK	X X	X X	XX X
SQUIB FIRING	X X	X X	X
BATTERY DISCONNECT	X X	X X	X XX

Block 1 2 3

TABLE 4. Alert codes used for diagnostics. An X indicates a ping and a blank indicates no-ping. There are four equal .25 second intervals per block.

the surface, the outputs from two amplifiers tuned at those frequencies are rectified and subtracted to reproduce the capsule frequency control logic level. In this way, logic "0"'s and "1"'s are transmitted from the capsule to the surface. The desired capsule voltages are digitized, serialized, and encoded for transmission to the surface.

This system transmits at 102 bits per second. It was decided to use a format compatible with digital telemetry circuits marketed by Coded Communications Corp. of Costa Mesa, California. Each transmitted word has associated with it a 5 bit synchronization pattern or its complement (alternating with each word), a 5 bit channel I.D. number, the 12 bit data word and a parity bit. The words are put into a parallel to serial converter, then a bi-phase encoder, and transmitted at a constant rate. The bi-phase encoder is simply a logic circuit which transmits the bit clock if a "1" is present, or the complement of the bit clock if a "0" is present. This has the advantage of transmitting the bit clock frequency along with the digital data. The surface decoder has a phase-locked loop which locks to the frequency of the bit clock so that synchronization is assured.

It also decodes the bi-phase code to 0's and 1's. In order to convert the incoming serial data back to a parallel format, the decoder must synchronize to the sync pattern, maintain sync through a short burst of errors, and regain sync as soon as possible after a long burst of errors. Three synchronization states are defined. The SEARCH state assumes no prior information and scans all of the incoming data for a sync and sync pattern (sync is the complement of sync) and advancing channel I.D. numbers. When a good pattern is observed, the system transfers to a CHECK mode. In this mode the system looks for a valid sync pattern only at the next appropriate place in the bit

stream (plus or minus one bit). When four valid patterns in succession are observed, the mode changes to LOCK. During CHECK, if an invalid sync pattern is observed, the system immediately reverts to SEARCH. However, once the LOCK mode is reached, four consecutive invalid patterns must occur to reset the system to SEARCH. Using the channel I.D. numbers, the data is stored in a memory which is accessed using thumbwheel switches and a four-digit front panel display. Parity errors are indicated by a blinking display. Figure 24 is one of the diagnostic log sheets used. All of the sensor outputs and battery voltages are transmitted. Thus proper sensor operation can be easily varified.

The diagnostics mode of the acoustic system was extremely trouble-free. Reliable diagnostics were received to a 45° slant range. Because of the fairly narrow beam pattern of the receive hydrophone, and because multipath interference increases for large slant angles, the slant angle appeared to be the determining factor in establishing acoustic communication. This holds for commands as well as diagnostics. The bit rate of 102 bits per second was decided upon rather arbitrarily and does not represent an upper limit, which is probably determined by multipathing, causing data bits to overlap. For capsule to surface transmission, the reflection from the surface is the most important multipath. It may be reduced by using a receive hydrophone with poor sensitivity in the backwards direction. This eliminates the surface reflection, which can exceed the direct signal by many times. At large slant angles, the direct and reflected signals come in at more nearly the same direction, so they interfere with each other more. At 100 bits per second, each bit is 10 msec long, so a level change could occur every 5 msec. If the receive hydrophone is five feet below the

DIAGNOSTICS

Sheet ___

NOTE: RESET MEMORY BEFORE EACH SCAN

- Tilt 1024
- Tilt 4096
- Amb. Temp.
- Grav. Temp.
- Pressure
- Tide
- Grav. out
- Grav. out
- Grav. out
- Grav. out
- Grav. out
- Grav. out
- Grav. out
- Grav. out
- Grav. out
- Grav. out
- Rec. Op.
- +12 R
- +24 Acou.
- +24 H
- 24 H
- +12 B
- 12 B
- +24 AC.B.U.
- +12 D.B.U.
- 12 D.B.U.

Ch	A	B	C	D	E	F	G	H	I	J	K
1											
2											
3											
4											
5											
6											
7											
8											
9											
10											
11											
12											
13											
14											
15											
16											
17											
18											
19											
20											
21											
22											
23											
24											
25											
26											
27											
28											
29											
30											
31											

LEAST COUNTS

- 0 = -10v.
- 2048 = 0v.
- 4096 = +10v.

One least count = 5 mv.

FIGURE 24

surface, the reflection comes in 2 msec later. The amplitude varies due to the focusing and defocusing effect of waves and swell, so this delay causes significant interference. In Appendix III, other aspects of the acoustic system are discussed.

Gross Tilt, Leak, and Release Electronics

Since the detailed bottom conditions are often unknown, a sensor which would initiate an alert code if a tilt of more than 15° was designed. It consists simply of an array of four mercury switches mounted so that the required tilt ~~cross~~ the contact. This provides a logic level to the alert code generator which initiates the gross tilt alert. The gross tilt function was extremely useful during the RUM-ORB deployment (Appendix III) where the RUM control line and capsule buoy line became entangled. Gross tilt alerts were also heard during the deep ocean test when the buoyancy of the polypropylene line was enough to enable the surface buoy to drag the capsule along the bottom.

A good leak detector is crucially important. Initially, parallel strips of lead tape separated by $1/8$ to $1/4$ inch were run around the edge and along the bottom of each lower hemisphere. Figure 25 shows the circuit used to indicate a leak. During the first deployment, a leak of about one drop per day occurred, beginning on the second or third day. Normally, the capsule would be deployed in one day, diagnosed, and left. A leak after the ship leaves station would result in an automatic release and the probable loss of the capsule. So, it was decided to install a second leak detector that indicated a puddle. The first leak detector would initiate a leak alert, but only the puddle detector would release the capsule.

Figure 26 is the squib fire circuit, which fires the explosive cable cutter and line release. The 28V power is supplied by a TR 413

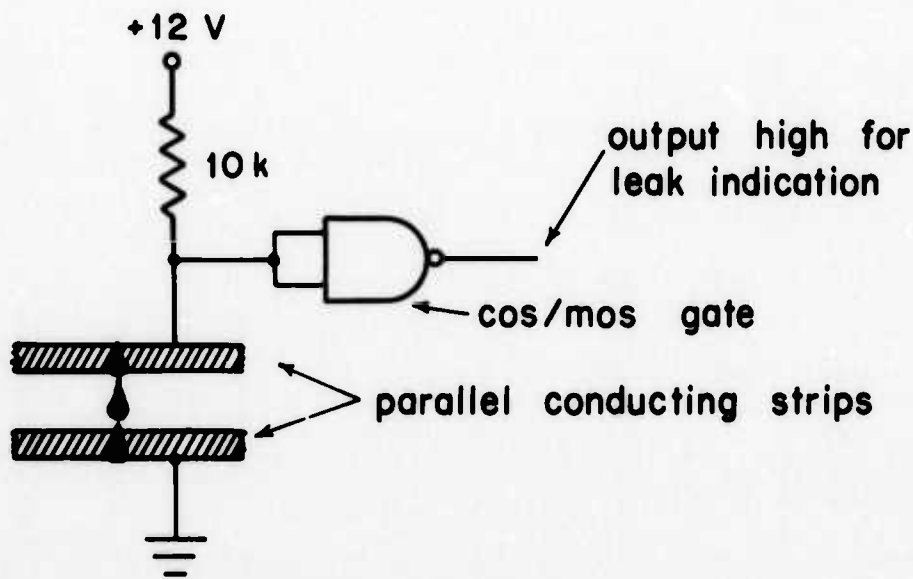

LEAK DETECTOR

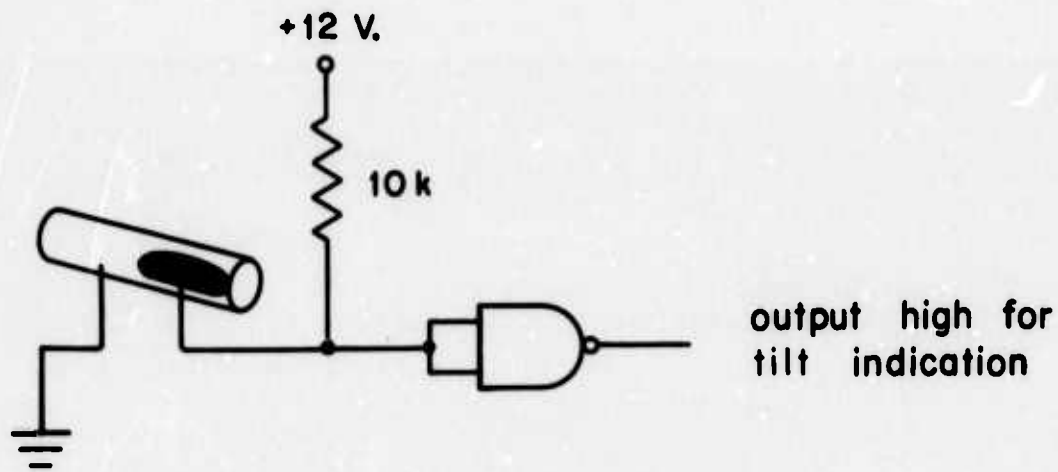

GROSS TILT DETECTOR

Figure 25

mercury battery. The input logic level turns on the power through Q_2 , which charges both the 5,000 μfd and 10 μfd capacitors. When the trigger level of Q_3 is reached, Q_3 triggers Q_4 , which discharges the 5,000 μfd capacitor through the squib. The resistance of the squib is about 1 Ω and for a pre-launch test we require the current to be at least 5 amps after 10 msec. The cable cutter has two heater wires, so two circuits are used in case one fails. Since it is extremely undesirable to fire explosive devices at unexpected times, and this circuit puts out a fairly narrow pulse which might be unobserved on a voltmeter or oscilloscope, it is extremely important to ^{properly} monitor this circuit prior to capsule deployment to ensure that it is not firing. A test box with 1 Ω resistors across the squib fire connectors and logic latches connected to light emitting diode indicators is continuously connected to the firing circuits. Before launch the firing currents can be easily measured and false firing commands are easily detected because the indicator lights turn on and remain until manually reset.

III. Ocean Testing Program

The results of tests 1, 2 and 3 of the ocean testing program are described in detail in Appendices III and IV. The purpose of these tests was to correct system errors and gain experience with it in preparation for one month deployments in the deep ocean. Test 4 was just east of San Clemente Island ($32^{\circ}55.9'N.$, $118^{\circ}18.9'W$) from December 11, 1972 to January 4, 1973. The object of this test was to deploy the capsule without a line to a surface buoy so that a valid test of the seismometer could be made. Figure 27 shows a low resolution plot of the tide filter output for the entire run. The seismometer gimbal system failed to clamp, causing the offsets as the capsule settled into the ooze and the gimbals occasionally moved. The oscillations on the trend are the earth tides and the glitches toward the end are due to tape recorder errors. This record is rather noisy at very low frequencies, presumably because of the ooze on which it was emplaced and the unclamped gimbals.

Figures 28 and 29 are plots with greater resolution, showing the noise level between .5 cycles/minute and 3 cycles/hr on the seismic filter (PHILTRE) plots and the lower frequency TIDE signal. One point is plotted every 64 seconds, so earthquakes will not be apparent. Figure 30 shows the sections of the PHILTRE output plotted at 10 minutes/inch of full size plot so that earthquakes can be seen. Each channel was sampled every 7 seconds, so only the surface waves will be visible. The event shown is the Managua earthquake of December 23, 1972.

Another objective of this test was to determine whether tilts induced by ocean currents would add significant noise at the accelerometer

TIDE

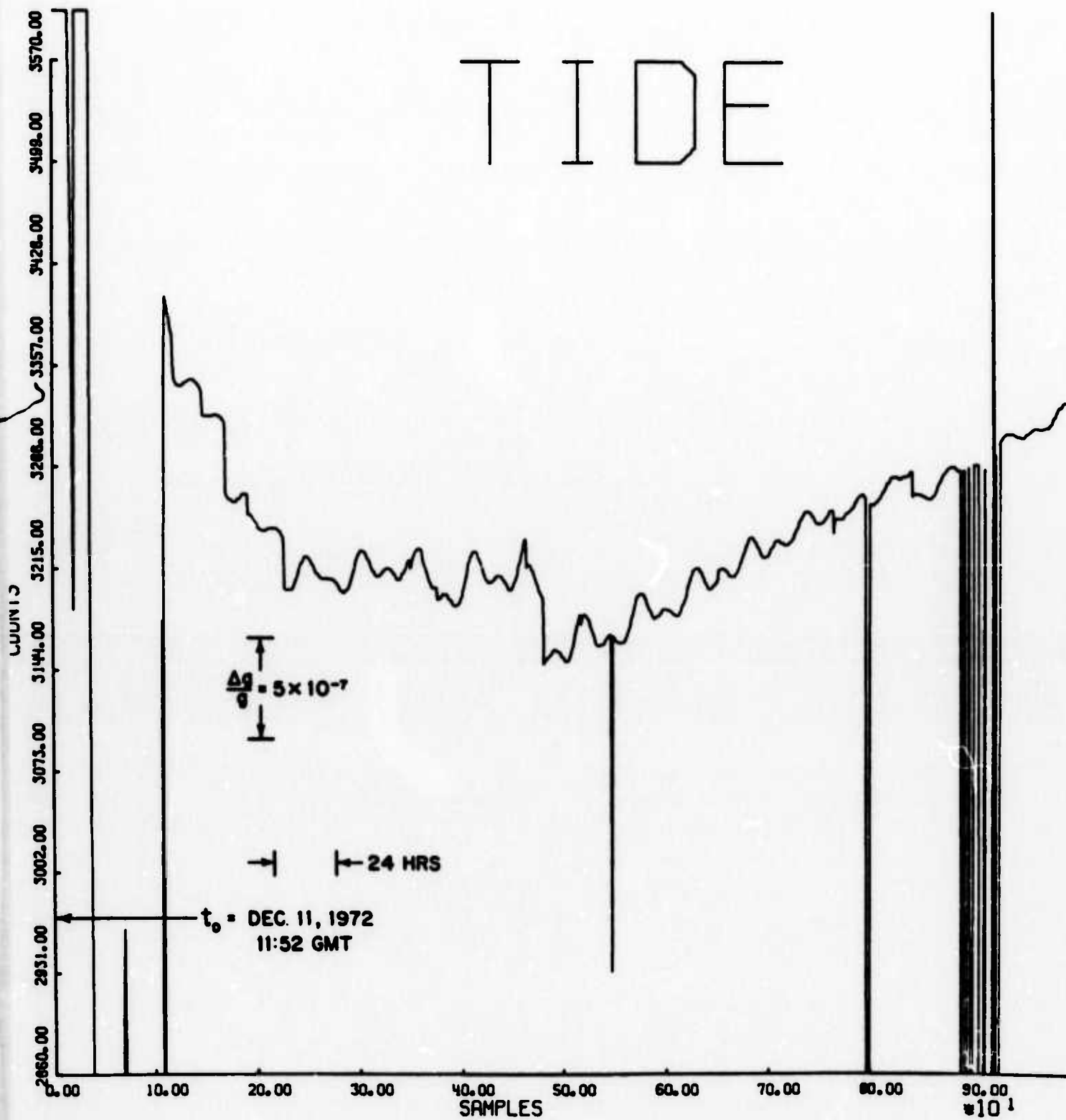
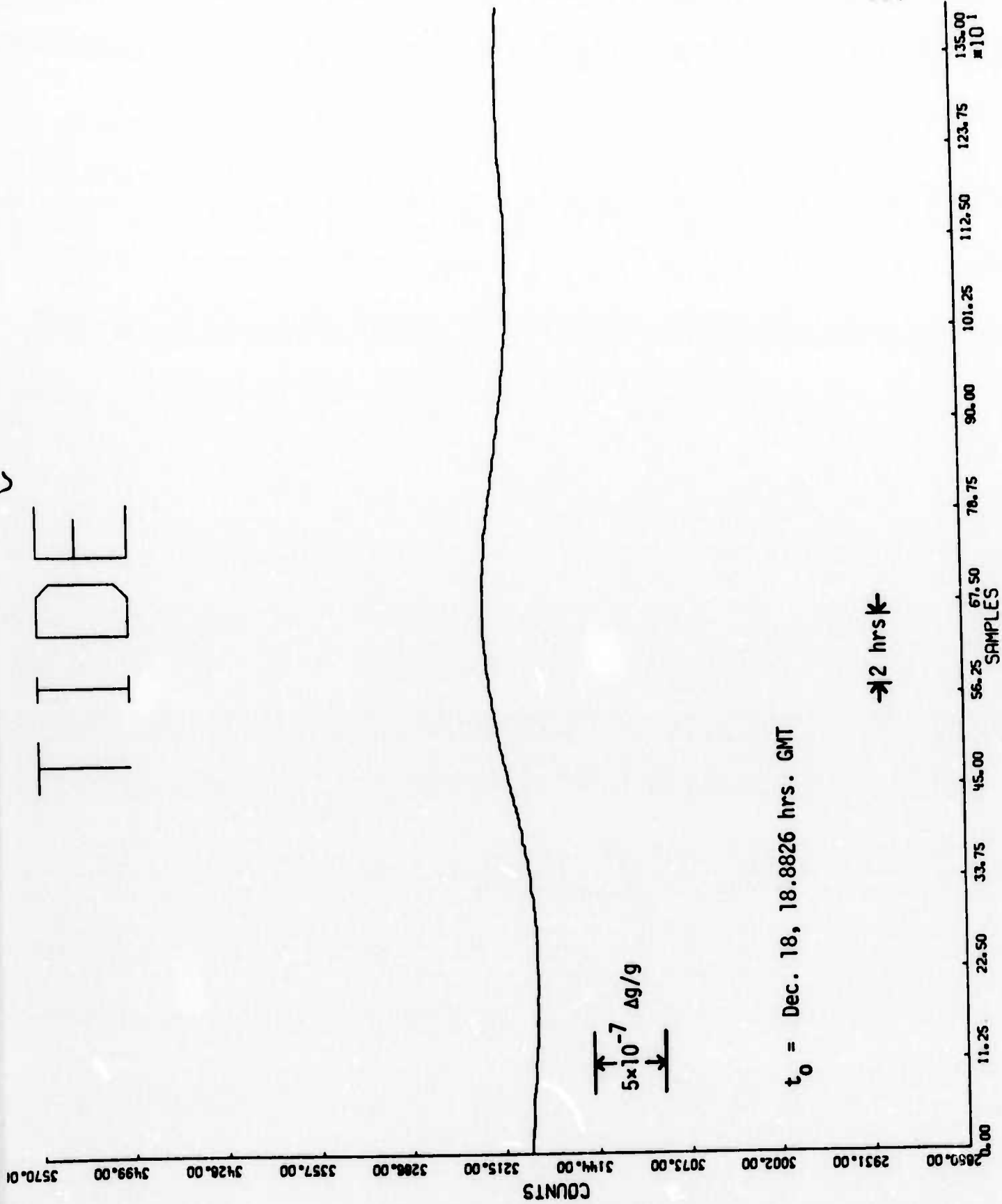

Figure 27

TIDE



5980 01/31/73 31

Figure 28

PHILITRE

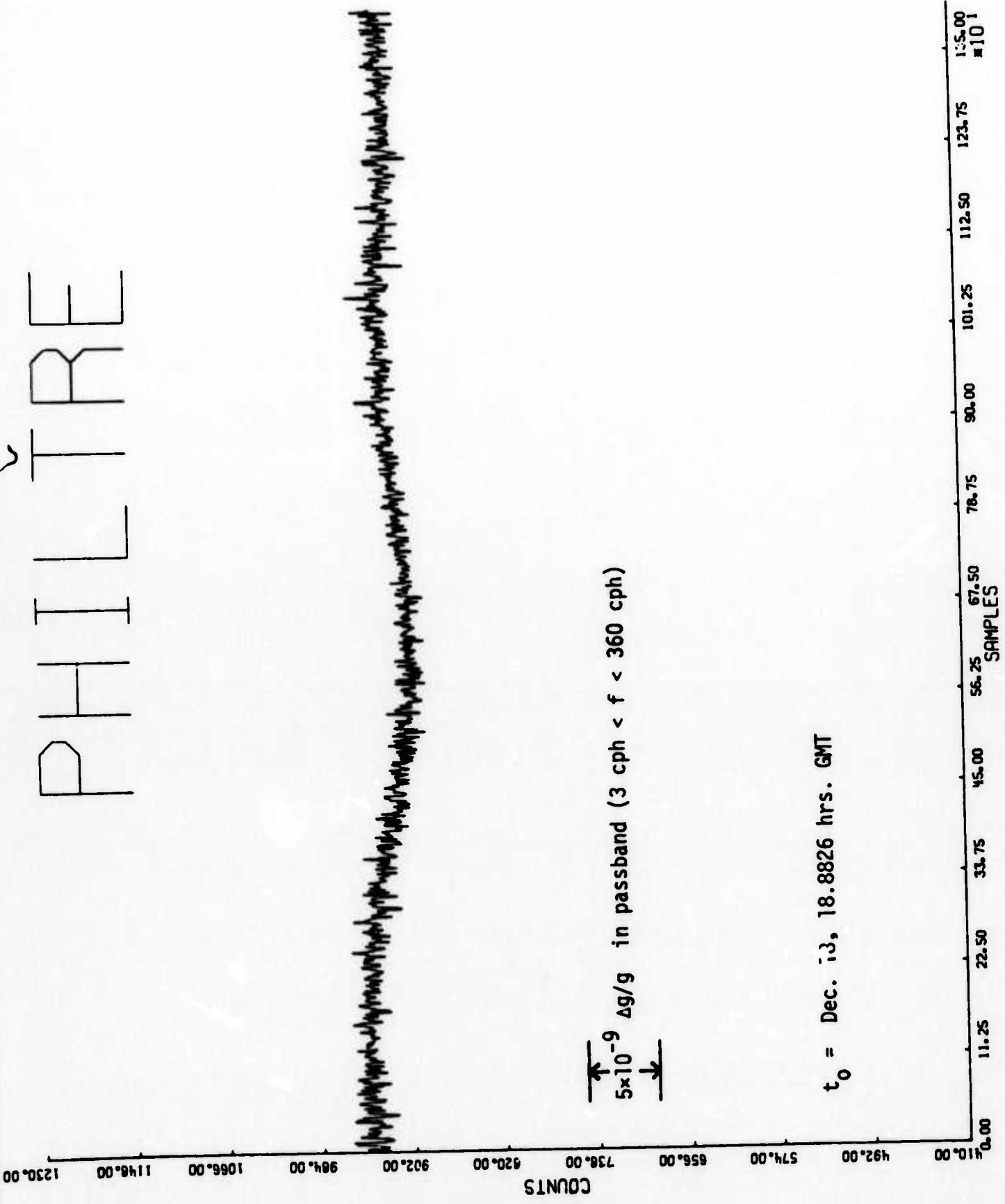

t₀ = Dec. 13, 18.8826 hrs. GMT

5980 01/31/73 32

Figure 29



4 volts

Managua earthquake

Dec. 23, 1972, 6 hrs, 32 min GMT

10 min

16144.63 16228.00 16313.39 16397.75 16482.13 16566.50 16650.88 16735.25 16819.63 16904.00 16988.39 17072.75 17157.13 17241.50

Figure 30

output. Unfortunately, the tilt-meters did not unclamp for this test, so this effect could not be determined directly. The noise level observed through the seismic filter is comparable to that observed when the capsule was operated in the IGPP vault, which is on the ocean front. Because the bottom at the deployment site was extremely oozy (vane shear strength $<.2$ psi), it is surprising that the noise level was as low as that observed.

The fifth deployment was made approximately 240 miles southwest of San Diego ($30^{\circ}40.1'N$, $121^{\circ}18.2'W$) from March 21, 1973 to May 9, 1973. This is 120 miles beyond the continental shelf in 2,000 fathoms of water. The purpose of this deployment was to test the system in the deep ocean, record long period body waves and surface waves from distant earthquakes, record ground noise, and record the solid earth tides. Again, the tiltmeter did not unclamp. The acoustic command system also failed to respond on recovery, so release was accomplished by the backup timer. However, accelerometer data was recorded. Figure 31 is a plot of the seismic filter output showing two time series of background noise and two containing earthquakes. One was a magnitude 5 in the Gulf of California at $25^{\circ}50'N$, $109^{\circ}40'W$. ($\Delta \approx 10^{\circ}$). The second event occurred near Nicobar Island and had a surface wave magnitude of 6.5. The trace below the Nicobar Island event is a continuation of the above trace and shows long period energy arriving well after the main surface wave train. Figure 32 is a plot of the spectral density of a section of the series which has no earthquakes. The normal microseism peak is observed between 5 and 8 seconds period. The 14 second microseism peak is not observed. For comparison,

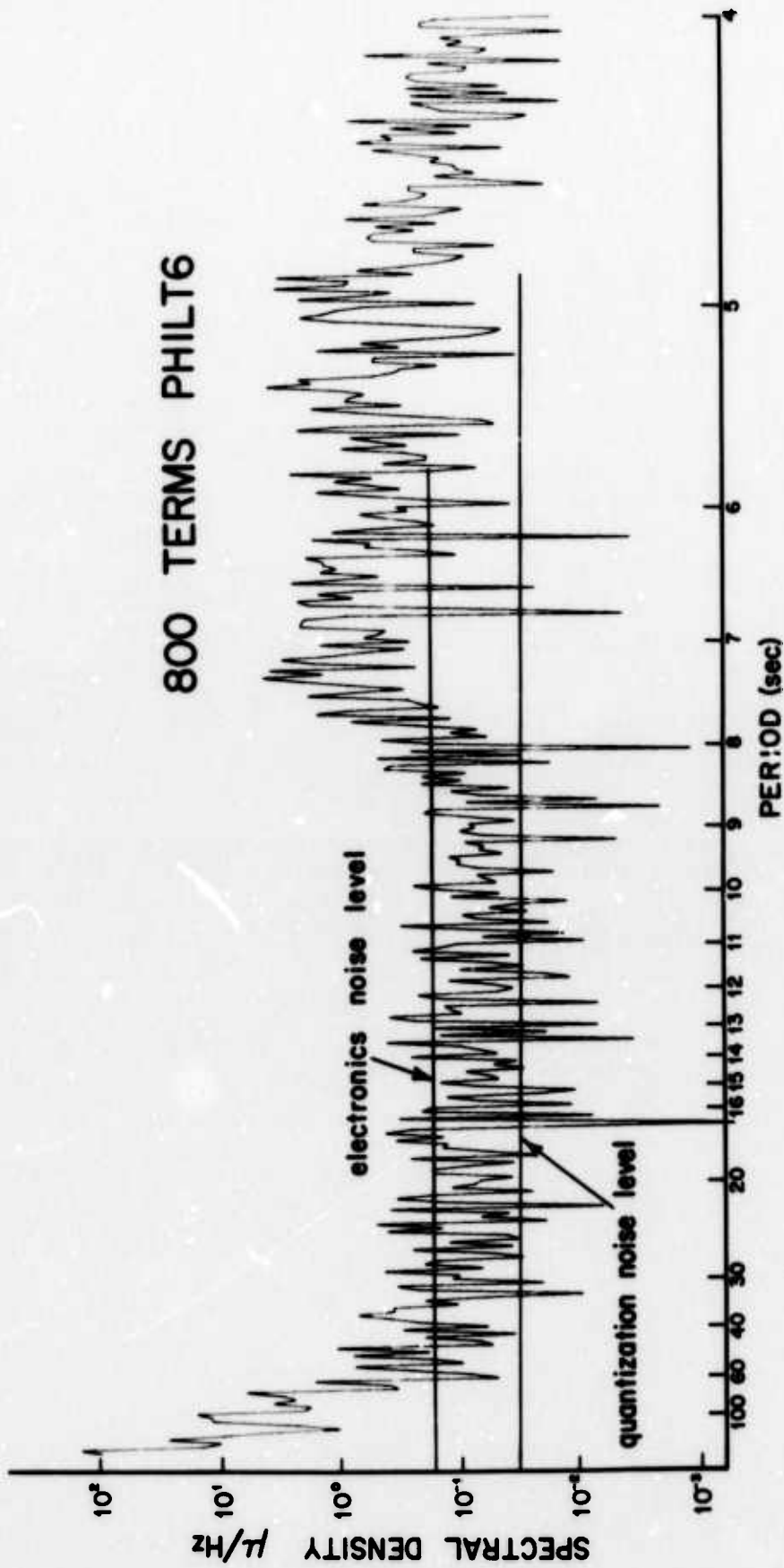

Figure 32

Figure 33 (Whorf, 1972) is a plot of noise spectra at Pinon Flats, the UCSD geophysical observatory approximately 100 miles northeast of San Diego. The 6 second microseisms are equivalent to a rather quiet day at this land site and the 14 second peak would be below the electronics noise level of the ocean bottom capsule. It should be noted that the accelerometer used in the land work was a considerably improved version of the capsule accelerometer. A 20db lower noise preamplifier and closer capacitor plate spacing was used. It also had considerably better thermal insulation. These modifications were not easily incorporated into the capsule. Thus, the question of the ground noise level at 20 seconds has not been resolved with these data. However, the microseism level is not 10 to 20 db higher than a reasonably quiet land site as reported by Bradner and Dodds (1964). In fact the 6 second peak is comparable to that recorded on land. Further analysis of the records will be published at a later date.

As a result of the last two tests, several problems are apparent. The most serious is the acoustic command system. The EDO command receiver and command decoder is marginal at best. The source level of the capsule transmit transducer is too low for effective deep ocean search and ship's positioning, and the command receiver is of poor design and is unreliable. Another trouble spot has been the gimbal and tiltmeter unclamp during the deep ocean deployment. It behaved satisfactorily on previous ocean tests, so we believe that problem to be of a minor nature and that the system, although somewhat temperamental, could be made to work reliably.

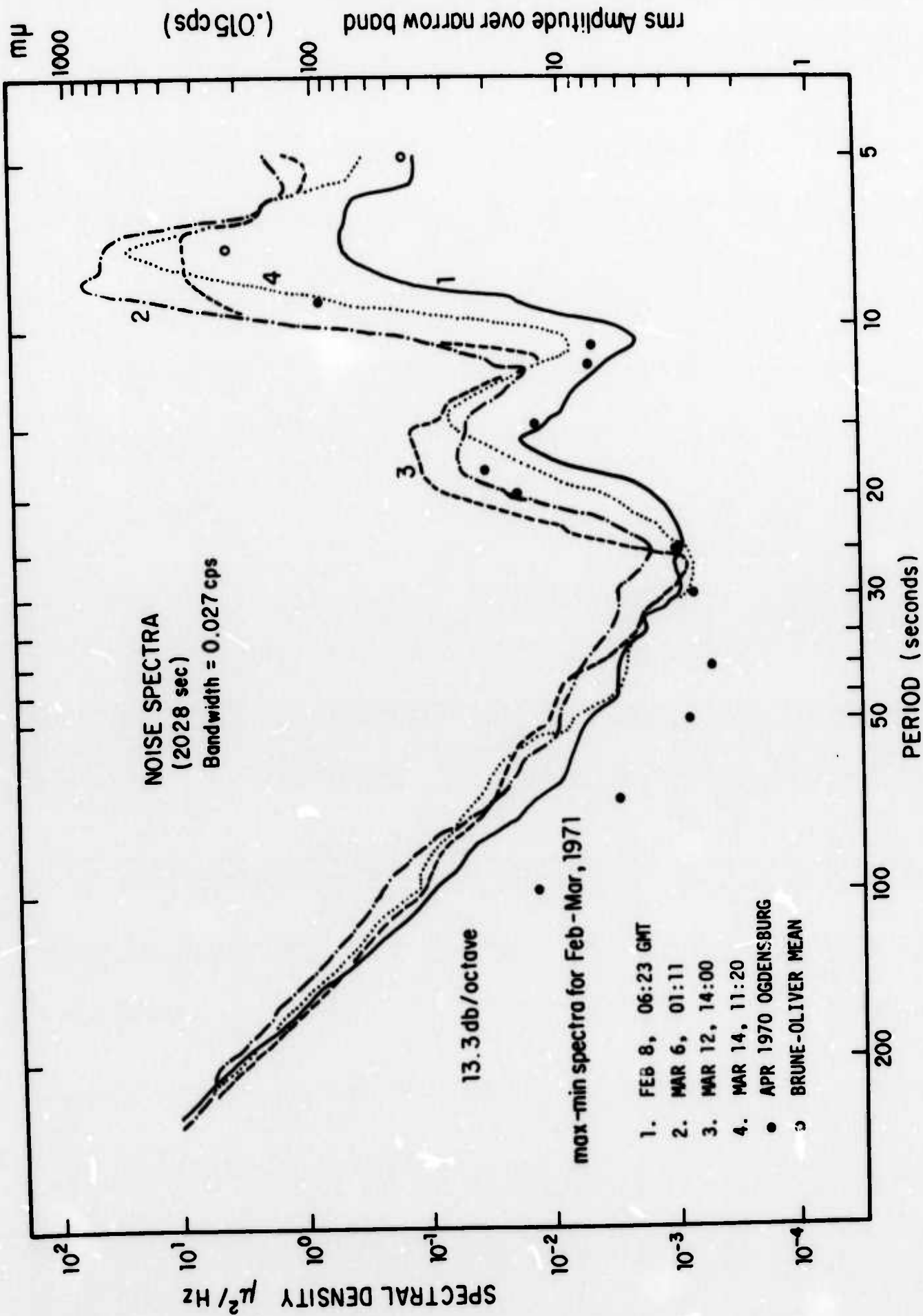

Figure 33

IV. Overall Capsule Evaluation

As a research tool, this capsule has several drawbacks. Its size and complexity requires that a great deal of time be spent on checkout and other preparations for deployment. Expendables cost per deployment is also rather high at about \$2,000. However, versatility and sophisticated diagnostics capability is absolutely essential when complex or fragile sensors are employed. Also, preliminary work under unknown conditions will have a greater probability of success with this capsule. However, once preliminary work has been done and if rugged sensors (seismometers) can be obtained whose characteristics in an ocean bottom capsule are known, a smaller, simpler, and less expensive unit becomes desirable. Then, array work, which is important for most seismic experiments, becomes practical.

The most important science that CINDHI can perform in its present configuration is to study surface wave dispersion, measure solid earth tides, and measure very low frequency vertical displacement. Surface wave dispersion is an extremely important tool, as the velocity structure of the crust and upper mantle can be determined. An array of similar instruments would allow the study of the structure of localized areas using surface waves from many sources. Higher order Love wave modes which have similar group velocities can be sorted out using phase velocity filtering of array data. The Block-Moore accelerometer is not necessary to perform surface wave measurements, but earth tides and vertical displacement measurements

require an instrument with the D.C. response of the Block-Moore. The response of the instrument to water tide or storm front pressure loading will give information on the structure beneath the station (W. Farrell, 1972; NAS-NRC Mid-Atlantic Ridge Report, 1972). Vertical motion such as that occurring at spreading centers might also be observed in conjunction with a pressure gauge, such as that used by Snodgrass and Munk for tide measurements and in the MODE project in the Atlantic. So, in summary, the capsule CINDHI is a very useful tool for sensor development and exploratory work, but simpler, more specialized capsules should be developed for array work.

REFERENCES

- Block, B. and R.D. Moore, Tidal to seismic frequency investigations with a quartz accelerometer of new geometry, J. Geophys. Res., 75, (8), 1493-1505, 1970.
- Bradner, H., I.S. Jerphanion, and R. Langlois, Ocean microseism measurements with a neutral bouyancy free-floating midwater seismometer, Bull. Seis. Soc. American, 60, (4), 1139-1150, 1970.
- Schneider, W.A., P.J. Farrell, and R.E. Brannian, Collection and analysis of ocean-bottom seismic data, Geophysics, V.XXIX, (5), 745-771, 1964.
- Latham, G.V., and G.H. Sutton, Seismic measurements on the ocean floor, Jour. Geophys. Res., 71, (10), 2545-2573, 1966.
- Whorf, T., Teleseismic and earth noise monitoring with the Block-Moore quartz accelerometer, Geophys. J.R.Astr.Soc., 31, p205-238, 1972.
- Bradner, H., and J.G. Dodds, Comparative seismic noise on the ocean bottom and on land, Jour. Geophys. Res., 69, p4339-4348, 1964.
- Farrell, W.E., Deformation of the earth by surface loads, Rev. Geophys. and Space Physics, Vol. 10, No. 3, p761-797, 1972.

CABLE CUTTER DEVELOPMENT AND TESTING

Introduction

Due to the unique nature and expense of the Benthic Array instrument, the specification for the underwater release system demands extreme reliability of operation. The added constraint of simultaneous electrical release compounds the difficulty of the problem. Operationally the release must meet the following requirements:

1. Capable of operation at 10,000 PSI in the deep ocean with a 10,000 lb. payload.
2. Corrosion and fouling resistance from surface depths to maximum operating depth for a minimum of 45 days.
3. Compact enough to be used in two configurations in the small space between the capsule and battery pack.
4. As safe and simple as possible to handle even in an explosive atmosphere if necessary (such as gasoline fumes on a work boat).
5. Cost per unit not to exceed that of a battery pack and frame unit.
6. Reuse of main components if so desired.
7. Reliability of the unit as independent of handling at sea as possible since people tend to make increased numbers of errors while at sea.

Investigation showed very similar requirements had been met in the deep space environment where subsequently explosively actuated links were used. These included exploding bolts, cable cutters, bolt cutters, pin pullers, and similar devices. The U.S. Government spent millions of dollars developing reliability data for these devices, yet the price per unit is extremely low. Therefore, it was decided to follow this route and adapt an existing design or develop a new design for undersea use. The

major manufacturer's in the explosive actuation device market were contacted, but all their existing products failed to meet the requirements. Therefore, a development program for a one-inch capacity cable cutter was initiated in conjunction with Horex Incorporated.

Design

The instrument package is held on the battery/ballast pack by a 9/16" plow steel cable. Six dual wire double insulated, underwater electrical cables come from the batteries to furnish the total instrument power. All cabling must be severed to affect a release and allow the instrument package to float to the surface. This requires a one-inch opening for all the cabling. For the relatively short periods of deployment 316 S.S. was chosen as the body material. Longer deployments would require a different choice of material to avoid crevice corrosion problems around threads and O-rings which might result in a leak and, thus, a failure (Attachment 5). Double O-ring construction gives maximum insurance against water leakage into the propellant chamber.

Since successful operation of a cable cutter demands a sharp blade, a material not prone to pitting or general surface corrosion in the sea is mandatory. Titanium alloys meet this general requirement and 6Al-4V-Ti was the logical choice due to availability and proven performance. The unit as depicted in Attachment 1 is representative of the final design. Eight developmental tests were performed with three cutter bodies. Three different blade materials as well as varying loads were tested to determine cutting performance at both 10,000 PSI pressure in oil and at atmospheric pressure in air. Results of the testing are given in Attachment 3. Five deep ocean drops of varying length as well as one aborted deployment resulted in a

perfect record of performance. Drop dates, durations, and depths are given in Attachment 4. One small spot of crevice corrosion occurred on a cutter anvil after a 25 day deployment. This occurred under a small piece of black plastic tape which stuck to the anvil as it was placed around a tape wrapped cable. It resulted in no deterioration of performance.

ATTACHMENT 1

The underwater connector used on the back of the cartridge is #XSG-4-NCL made by Branter and Associates, 3462 Hancock Street, San Diego, California 92110 for Wayne Hill. All 316 S.S.* parts are electro-polished and passivated to enhance corrosion resistance. Titanium parts are thoroughly cleaned after machining. All 6Al-4V-Ti parts are made from annealed alloy. Heat treating the titanium alloys for strengths better than 150,000 PSI yield can make them susceptible to stress-corrosion cracking in sea water, especially at elevated temperatures, and should be avoided at all cost. Machine drawings are attached.

*Note: If any piece is to be heated above 850°C, one should either quench cool that piece or use 316L or the Ti-Cb stabilized grades. This avoids the possibility of grain boundary carbon precipitation, and the accompanying grain boundary corrosion.

ATTACHMENT 2

I. PREPARATION FOR ASSEMBLY

- a) Check the assembly drawing and be sure that all necessary parts of the unit are before you.
 1. body
 2. anvil
 3. piston
 4. cartridge
 5. blade
 6. shear pin
 7. Three O-rings
 - a) 2-210
 - b) 2-017
 - c) 2-117
- b) Clean each piece thoroughly checking for small particles of metal or any burrs that could sever, scratch or cut an O-ring.
- c) Look inside body and be sure there are no linear scratches that could allow leaks by O-rings under high pressure.
- d) Check each O-ring groove for linear scratches and check the face of the cartridge for any scratches that could allow pressure leak by in that area.
- e) Assemble the unit without any O-rings very carefully to make sure that all pieces fit. Do not tighten the cartridge completely in the body or you might take a chance of seizing the threads and not be able to remove it.
- f) Disassemble the unit again and make sure that there are no scratches resulting from your assembly and disassembly.
- g) Again check the list of O-rings that is included above against the O-rings that you have to use in the unit.

- h) Check each O-ring individually for defects in manufacture, small scratches, or any suspicious looking area that might result in a leak, discarding any O-ring that shows signs of any irregularity or problem that could develop into a leak.
- i) Once again, check to make sure that all O-ring grooves are clean and clear of scratches.

II. ASSEMBLY

- a) Grease each O-ring lightly with silicon grease.
- b) Place the O-ring on the appropriate part as indicated in the assembly drawing. Be very careful to avoid lint or dust as under high pressure they give pressure concentration points which allow leaks.
- c) Install the blade in the cutter body.
- d) Install the shear pin, bending each end so that it remains in place.
- e) Bolt on the anvil plate with the four bolts that are of the same alloy as the body. However, do not overtighten them since that could result in the bolts seizing into the body making it impossible to remove the anvil at the time of installation on the cable.
- f) Lightly coat the first inch or so on the inside of the O-ring seal on the body with silicone grease.
- g) Take the piston and insert it into the body with the O-ring in place on both the slip face and back of piston. Check to be sure that the hole in the piston has engaged with the shaft of the blade.
- h) At this point be sure to double check and make sure that no burrs have been left around the inside of the body which could have ruined the

O-ring. Push the back of the piston no further than about a quarter of an inch from the end of the O-ring seating surface of the body. This will allow the face of the cartridge to seat tightly against the face O-ring and push the piston the rest of the way forward. This gives a double O-ring seal and double safety on the seal of the unit.

- i) Take the cartridge with the O-ring installed and screw it into the body. You will be able to feel the O-ring go into the slip seal of the body and engage with the back of the piston, where the O-ring will seat on the face of the cartridge. Continue to screw it forward in the body until about a quarter of the last thread remains. At this point stop and spread some zinc oxide compound around the back of the body where the cartridge face will seat. This will serve to give some crevice corrosion protection on a temporary basis to the body and the cartridge. Continue to screw the cartridge in until it is well-seated against the back of the body. Tighten it as tight as possible with a small pair of pliers. The unit is now assembled, loaded, and ready to operate.

III. CHECKOUT

- a) With the blade and cutter and anvil in the unit, clamp it down and cover the end openings with a piece of metal so that firing would not result in any dangerous chips flying around the room.
- b) Check the electrical continuity between the pairs of wires on the plug. Each pin pair on the Electro-Oceanics connector is a bridge wire pair which should have approximately 1Ω resistance. When testing these, be

very careful not to exceed the lower firing limits of the current or to introduce any static charges that could short from the body through the primer and fire the unit.

- c) If these all appear correct, the unit is ready to be plugged into the timing firing circuitry and used.
- d) Any immersion of the unit requires complete disassembly, complete cleaning and reassembly as above. One should always take care to replace the shorting plug and short that plug to the body of the unit to avoid any chance of accidental firing while handling. It is also advisable to keep a dummy cable in the unit to avoid blade chipping if the unit does fire accidentally.

IV. INSTALLATION

- a) At the time of installation, one will remove the four bolts that hold the anvil, slip the cutter over the cable and replace those bolts in the anvil. Under the head of these bolts and at the face of the body where the anvil seats on the body, spread some zinc oxide compound to again protect against crevice corrosion.

ATTACHMENT 3

Preliminary testing performed by Wayne Hill and Gene Waide at Scripps Institution of Oceanography.

In all tests below cable cutter main bodies postons, cartridge bodies, and anvils were of 316 S.S. All cabling to be cut was 9/16" diameter plow steel with rope center surrounded by 9 each wire bundles 2-18 AWG copper with neoprene insulation and jacketing. The shear pin on all tests was 3/32" diameter 303 S.S. annealed. All tests were performed at room temperature with a vinyl closure over the charge cavity of the cartridge. Prime was 110 mg. #19 pressed at 15,000 PSI. All pressurized testing was done in hydraulic oil at 10,000 PSI.

Test	grams load #72	Knife	Pressurized	Results
1	1.204	Ti	Yes	Cut cleanly
2	.600	Ti	Yes	Cut only 1/2 of target
3	1.003	Ti	Yes	Cut all but 3 copper wire strands
4	1.200	Ti	No	No target used - all products of combustion contained
5	1.204	Ti	Yes	Cut cleanly
6	1.200	316 S.S.	Yes	Cut cleanly
7	1.000	440 S.S. Rc 58	Yes	Knife broke, did not cut cable
8	1.100	Ti	Yes	Cut cable

Comments:

1. Wider blade to cut extrudable material.
2. Bevel by-pass holes to protect piston for reloading.
3. Larger body diameter to prevent stretching.
4. Cartridge end scores bore when removing to reload.

All comments except item 4 have been taken into account on present drawings.

ATTACHMENT 4

Cable cutters of the above design were used as both the primary acoustic actuated and backup timer actuated releases on the deployments listed below. No cutter was fired on Drop 1 because of electronics problems within the capsule. The five cutter firings worked as designed.

Drop #	Location	Water Depth	Dates of Deployment
1	32°56.2'N 118°18.8'W San Clemente Island	4000 feet	March 13-17, 1972
2	Off Catalina Island	2600 feet	July 24-25, 1972
3	San Clemente Island	4000 feet	August 5-8, 1972
4	San Clemente Island	4000 feet	December 11, 1972 to January 4, 1973
5a	30°40.1'N 121°18.2'W	12,000 feet	March 14, 1973 (electronics failure fired the unit before reaching 500 ft.)
5b	Same as Location 5a	12,000 feet	March 21, 1973 to May 9, 1973

Careful inspection of both cutters after Drop 1 through 5a showed no problems which would cause a failure or degradation in performance. Evidence of shallow crevice corrosion was found on the anvil of the backup cutter after Drop 4, but this would have had no effect on operation. Drop 5b was recovered on the backup cutter due to an acoustic system failure so only one unit was available for evaluation. No problems were observed on this unit.

Due to the susceptibility of 316 S.S. to crevice corrosion, one should limit deployments of this cutter to 45 days. This does not mean to imply that all cutters would fail after 45 days, but rather, that due to the statistical nature of crevice corrosion occurrence, one would be taking a chance of a possible failure after this time. Attachment 5 outlines the materials changes necessary for a unit with unlimited deployment time.

ATTACHMENT 5

When one must design a release with maximum statistical reliability, one usually looks at the means of actuation first with methods and materials left as a second thought. When working in the harsh atmosphere of the ocean, this attitude is often disastrous. As previously stated, millions have been spent to prove the reliability and safety of electro-explosive actuation. However, relatively little has been spent on proving long term reliability of materials in the "generalized" marine environment. This "generalized" environment really includes the marine atmosphere, as well as the three basic areas of the ocean:

1. Splash zone
2. Surface water
3. Deep ocean

The list of basic, readily available materials which remain untarnished and uncorroded for unlimited times in all three zones is short:

1. Titanium alloys of certain types
2. Hastalloy C*
3. Inconel 625†

Galvanically these mix without any harmful effects for prolonged periods of exposure.¹ The deciding factors for use are typically strength, cost, and availability in desired forms. For this cutter the proven use of the 6Al-4V-Ti blade makes this material the logical blade choice. Bodies, pistons, and anvils could also be made of this same material, but galling of the bore would probably result as the piston was pressed out after the first

* Trademark: Cabot Corporation

† Trademark: International Nickel

¹ This statement is based on personal experience as well as discussions with Francis La Que on data taken by International Nickel.

firing. The use of either of the other two materials for these parts would help alleviate this problem. The present load in the electro-explosive cartridge has proven to be considerably higher than necessary for rated operation. The end of the piston is typically extruded into the four by pass holes upon firing. This results in damage to the bore when one attempts to remove the piston for reload. Since the blade penetrates into the anvil better than $1/16$ " as well as stretches the four hold down bolts about $1/16$ ", one could place $1/8$ " thick washer of PVC, nylon, or teflon in front of the piston to help absorb this extra, unnecessary force. One would probably then be able to easily remove the piston for reloading, while maintaining a sufficient load to assure operation even in the most growth fouled conditions.

ATTACHMENT 6

Advantages of the underwater cutter:

1. Safety in handling and operation is the best of the commonly used explosive devices.
2. Paralleling releases for added reliability or backup is a simple matter of stacking one above another, rather than construction of a complicated mechanical system.
3. Main components can usually be reused and after multiple operations price per use drops considerably under price per unit.
4. Easy to install and less chance of human error than in complicated mechanical systems.
5. More compact than most mechanical systems which can handle the load on a 1" cable.
6. The extremely high impulsive energy of the explosive as well as the long term shelf life give reliable operation after long periods of exposure when biological fouling and corrosion are often a problem.
7. Extra wide blade assures cut on extrudable materials.
8. This blade design is much less likely to jam the cable in the through body hole than piston/blade types.

Disadvantages of the underwater cutter:

1. Expense per unit is higher than other commonly used devices.
2. The explosive force of the unit cuts a cable rather than forcing a link into two pieces, thus, no large force necessarily separates the cable which must pull from the cutter.
3. The cutter requires extremely careful assembly to maintain maximum reliability.

Problems in construction:

1. The existing 1" unit requires expensive machining in the by-pass holes and piston stop area. A one piece blade which would be essentially a piston with a sharpened end, as in the Horex 2800 series cutters, would lower unit price. However, this would affect safety and the ability to cut materials which extrude easily such as rubber.
2. The end of the cartridge expands and binds within the bore of the body. This results in scoring of the bore when reloading the unit and a possible leak-failure point.

Underwater Corrosion References:

1. Corrosion Resistance of Hastelloy Alloys, Cabot Corporation, Stellite Division, Kokomo, Indiana.
2. Guidelines for Selection of Marine Materials, International Nickel Company, New York, New York.
3. Inconel 625, Huntington Alloys Division, International Nickel Company, Huntington, West Virginia.

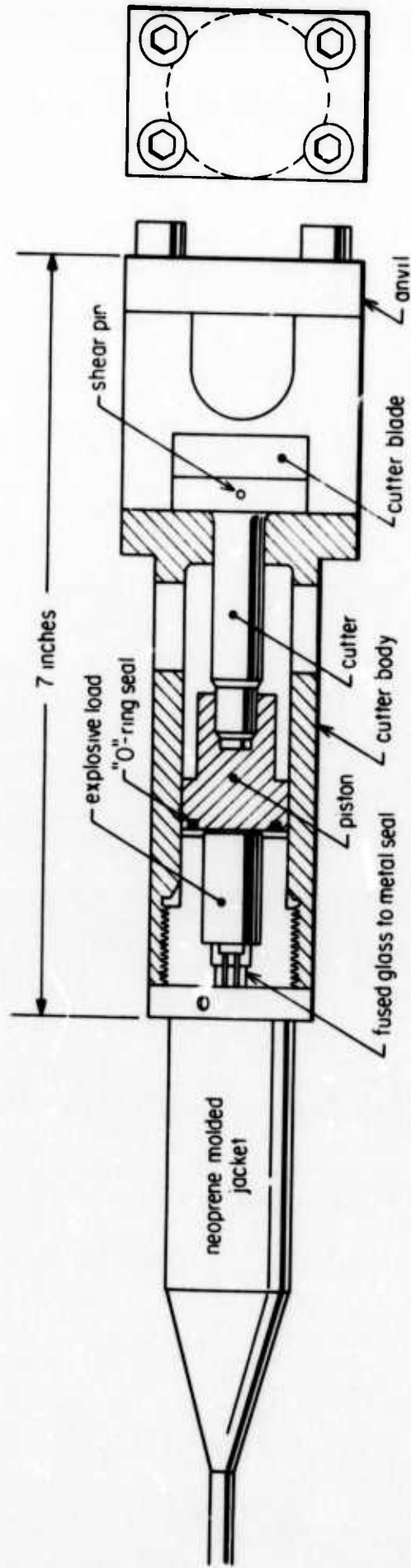

Figure I

APPENDIX II
UCSD DATA LOGGER

PHYSICAL DESCRIPTION

The Data Logger is housed in a card cage that contains three rows of circuit boards, each row capable of holding up to 11 boards. The Data Logger electronics occupy only eight boards, all in the center row, leaving the outer two rows available for other applications. A hinged front panel covers the center row and parts of the outer two rows. Control switches, indicator lights, and output jacks for the Data Logger are all located on this panel. These switches, lights, and jacks are hardwired to the card cage connectors via a flexible cable bundle. A single schematic (Honeywell Drawing No. 37270496) shows all the electronics and wiring included in the Data Logger. This includes the internal wiring of the individual boards, the card cage wiring, and the card cage to front panel wiring. On this schematic, the cards are referred to by their location in the card cage. These positions are identified as locations A1 through A11 corresponding to the 11 card locations in the center row. Card A1 is at the hinged end of the front panel, A11 at the latch end. All switches, lights, and jacks are shown on the schematic. The locations of these switches, lights, and jacks are identified in the marked up drawing (Figure 1) of the front panel artwork.

Outputs to the tape recorder are as identified on the schematic.

Power inputs to the Data Logger are to Card All Pins 18, 19, and 20. Pin 18 is +12 VDC, Pin 19 is ground, and Pin 20 is -12 VDC.

Electrical control signals may be input to Pins 7, 9 and 11 of either cards A10 or A11. These signals are:

Pin 7: A +12 volt signal starts the data logger

Pin 9: A +12 volt signal stops the data logger

Pin 11: A +12 volt signal resets the data logger

Each of these inputs have a 100 K input impedance to ground. Front panel components are:

Indicator Lights: Shelly Model BEP-066-C-B-P
Type T-1, 12 Volt Lamp

Switches-Toggle: Alcoswitch MST 105D

Push-
button: Alcoswitch MSP 105F

Banana Jacks: E. F. Johnson #108-0901-001

All other components are identified on the schematic.

UCSD DATA LOGGER

FUNCTIONAL DESCRIPTION

The Data Logger samples eight analog input signals, converts these signals to a digital format, and records the digital information on a 7 track incremental tape recorder. One analog signal is sampled and recorded each second. The sequence of analog channel selection is controlled by the eight select switches on the front panel and the internal system clock.

The basic sequence or block is 64 seconds or 64 samples long. A 131.072 crystal clock is divided down to produce a 1 hertz square wave that, in turn, drives the 64-second counter. The 1/64 hertz square wave out of the 64-second counter, in turn, drives a 12-bit time code counter. The contents of the time code counter are stored on the tape during the first second of each 64-second block (when the 64-second clock is at zero). Converted analog data is stored during each of the next 63 seconds. The different sequences for sampling and storing the eight analog signals (channels 0 through 7) are briefly described below:

- Channels 6 & 7 are both selected--
Record channels 0-5 once (if selected), then repeatedly sample and record channels 6 & 7 until the 64-second clock reaches 63 and resets to 0. Repeat sequence every 64 seconds. If select switches 2

and 4 are in the "OUT" position, the sequence will look like:

```
64-second clock - 0 1 2 3 4 5 6 7 8 9...
                  | | | | | | | | | |
Selected channel - T 0 1 3 5 6 7 6 7 6...
```

T = Time

- Channel 6 or 7 selected (not both)--

The sequence is the same as above except that after the selected 0-5 channels have been recorded once each, the duration of the 64-second block is spent sampling and recording the selected 6 or 7 channel.

If 3, 4 and 7 are all "OUT", the sequence looks like:

```
64-second clock - 0 1 2 3 4 5 6 7 8...
                  | | | | | | | | | |
Selected channel - T 0 1 2 5 6 6 6 6...
```

- Channels 6 & 7 both "OUT" (not selected)--

Repeatedly sample and record the first four selected channels. If fewer than four channels are selected, sample the selected channels once each every four seconds. If channels 1, 2, 3, 4, and 5 are selected, the sequence looks like:

```
64-second clock - 0 1 2 3 4 5 6 7 8 9...
                  | | | | | | | | | |
Selected channel - T 1 2 3 4 1 2 3 4 1...
```

Once the Data Logger is started, it will record data in 64-second blocks continuously until the STOP button is depressed. Every 128 blocks, a 3/4-inch record gap is written on the magnetic tape. During the 64 seconds that make up the 128th block, no data is recorded. The record gap is generated, then the Data Logger

waits the duration of the 64 seconds for the start of the next 64-second period when data recording resumes. A record gap is also generated whenever the Data Logger stops.

The timing signals that control the sampling, converting and recording operations performed once each second are shown in Figure II. These signals are generated by a decade counter with decoded decimal outputs (I. C. 39). During the first half of each second, this decade is held reset by the inverted 1 hertz signal. During the second half of the second, the reset is released and the decade counter starts counting from the 16-hertz input signal. The counter reaches eight before being reset at the start of the next second. The functions of each decoded output are described below:

- "1" - ● If the 64-second clock is at zero, reset the multiplex sequence control.
 - If the 64-second clock is at zero and the stop flip flop is set, send a record gap command to the data recorder.
 - No function when the 64-second clock is not at zero.
- "2" - ● Not used.
- "3" - ● If the 64-second clock is at zero and the stop flip flop is set, the Data Logger halts.
 - No function if the 64-second clock is not at zero.

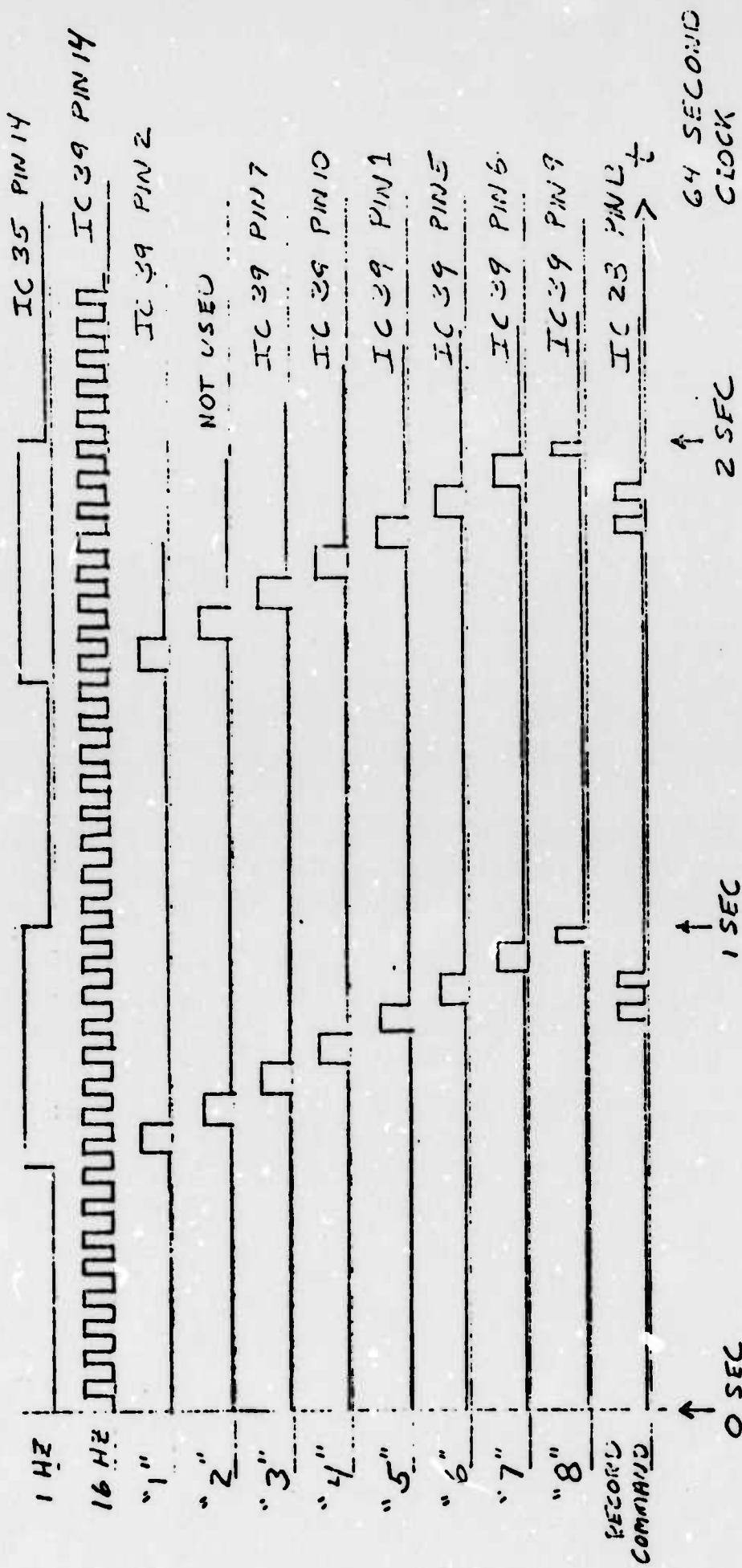

FIGURE II : UCSD DATA LOGGER TIMING DIAGRAM

- "4" - ● This signal is differentiated and input to the Analog to Digital Converter to command a conversion.
- "5" - ● If the 64-second clock is zero, this signal causes the six least significant bits (L.S.Bs) of the time code counter to be output to the recorder. The "RECORD" command subsequently strobes this information onto the tape.
- If the 64-second clock is not zero, the six L.S.Bs from the A/D converter are output to the recorder.
- "6" - ● If the 64-second clock is zero, the six M.S.Bs from the time code counter are output to the recorder.
- If the 64-second clock is not zero, the six M.S.Bs from the A/D converter are output to the recorder.
- "7" - ● Whenever the manual step flip flop is set, the Data Logger will halt on the trailing edge of this pulse with the manual stop flip flop reset. When the manual stop flip flop is again set (by depressing the corresponding pushbutton switch) the Data Logger resumes operation, stopping again at the trailing edge of the next "7" pulse.

- If the channels 6 and 7 select switches are both in the "OUT" position and the 64-second clock is at 0, 4, 8, . . . 60, this pulse resets the multiplex sequence control.
- "8" - ● This pulse advances the multiplex sequence to the next channel. A channel is selected and input to the A/D converter $3/4$ of a second before a conversion is commanded by pulse "4" of the next second. When the multiplex sequence control is reset by pulse "7", it is reset to a condition where none of the eight channels are selected. The subsequent "8" pulse advances the sequence to select the first channel specified by the front panel select switches.
- This signal commands the tape recorder to strobe the data on its six input data lines (plus one parity line) onto the tape. The record command pulses are blocked by the WRITE INHIBIT switch or when the 7 L.S.Bs of the time code counter are all at "1". (This occurs for a 64-second period once every $64 \times 128 = 8112$ seconds = 2 hours 15 minutes and 12 seconds).

Record
Command

The multiplex sequence control is contained on logic board No. 2 (location A7). The circuit is basically a 9-bit shift register. At any given time, one of the nine flip flops will be in the set condition, the remainder reset. The last eight flip flops correspond to the eight analog channels. The flip flop that is set gates the corresponding analog channel through the multiplexer to the A/D converter. When the shift register is clocked (by timing pulse "8"), the set condition moves to the right to the next flip flop that corresponds to a selected channel. When the set condition reaches the last two flip flops, it will either cycle back and forth between the two (if both channels 6 and 7 are selected) or hold at the selected flip flop (if only one of the two is selected). When the multiplex sequence controller is reset, the first flip flop is set and the last eight flip flops are reset so that none of the eight analog channels are selected. The next clock pulse will move the set condition from flip flop 1, to the first flip flop corresponding to a selected channel.

The functions of the front panel controls and indicators are described below.

SAMPLE CONTROL SWITCHES - Each switch controls whether or not the corresponding analog channel is IN or OUT of the sampling sequence.

SELECTED ANALOG CHANNEL INDICATOR LIGHTS - These lights (8) indicate which analog channel is currently being sampled.

These lights are disabled, as are the A/D CONVERTER OUTPUT lights when the INDICATORS ON-OFF switch is to the OFF position.

A/D CONVERTER OUTPUT LIGHTS - These lights indicate the output of the A/D converter. Bit 1 is the MSB and bit 12 is the LSB.

SYSTEM CONTROLS - START - This switch, when pushed, resets all counters and the multiplex sequence controller and starts the Data Logger.

STOP - This switch sets the stop flip flop (when it is pushed). The stop flip flop will cause the Data Logger to generate a record gap and halt when the present 64-second block is completed.

RESET - Depressing this switch causes all counters to be reset. The Data Logger continues to run (unless the STOP switch was previously pushed).

MUX RESET - This switch resets the multiplex controller and the 64-second clock.

TIME CODE RESET - Pushing this switch resets only the time code counter. Data Logger operation proceeds uninterrupted.

MANUAL STEP - Pushing this switch causes the Data Logger to operate for one second (sampling, converting and recording one analog channel) then halt. Each subsequent time the switch is pushed the recorder will resume operation for one additional second processing one more channel, then halt again.

INDICATORS ON/OFF SWITCH - In the OFF position, the SAMPLE CONTROL and A/D CONVERTER OUTPUT lights are disabled.

WRITE INHIBIT IN/OUT SWITCH - In the IN position, the data record and record gap commands to the tape recorder are blocked.

SEQUENCE NORMAL/HOLD - When this switch is placed in the HOLD position, the multiplex controller, the 64-second clock, and the time code counter are held in the condition they were in when the switch was thrown. The timing pulses are not blocked so the same analog channel is continuously sampled, converted and stored on the tape. When the switch is returned to NORMAL, the Data Logger continues on as it was before the switch was put to HOLD.

CLOCK OUTPUTS - The top row of jacks contain the outputs of the eight most significant bits of the time code counter. The most significant bit represents 2^{17} seconds. The total time code counter capacity is 2^{18} seconds which represents approximately 3.25 days.

The bottom row of jacks contains three frequencies derived from the 131.072 kHz countdown chain plus a signal ground jack.

APPENDIX III

RESULTS OF THE FIRST OCEAN TEST
OF THE OCEAN-BOTTOM BLOCK-MOORE
ACCELEROMETER PACKAGE

by

William A. Prothero, Jr.

Institute of Geophysics and Planetary Physics
University of California, San Diego

RESULTS OF THE FIRST OCEAN TEST OF THE OCEAN-BOTTOM
BLOCK-MOORE ACCELEROMETER PACKAGE

The test occurred in 4,020 feet of water on the east side of San Clemente Island. The capsule was deployed Monday, March 13, 1972 and recovered Friday, March 17. The weather was excellent and the seas were glassy smooth the entire time. The entire capsule was tested, including the EDO acoustic command and control system, the digital capsule diagnostics, the accelerometer and tiltmeter and their associated electronics, the data logging system and the explosive releases. A line to a surface buoy was connected to the capsule in the event that the release failed. The gain of the accelerometer was 40 db lower than its intended operating value so that the accelerometer would stay on scale when the buoy pulled on it. The surface buoy will not be connected except for early tests where the release system is not yet trusted. The overall system performance was quite good for a first deployment.

Troubles occurred with the acoustic command system. A misconnection to the explosive cable cutters prevented a release of the package as intended and recovery was made with the line to the surface. The rest of the system worked perfectly and a number of possible improvements became apparent during the test. A detailed description and evaluation of the performance of each capsule subsystem follows.

The Acoustic Command and Control System

The acoustic system was purchased from EDO Western Corporation and arrived approximately ten days before the capsule was to be deployed. The system initiates a command from the surface by first sending a 30 millisecond pulse of 9.25 khz acoustic energy. The bottom unit detects the pulse and responds by sending a 10 ms pulse at 13.5 khz. A command from the surface is then transmitted after a one second delay by a .5 second burst of 2 ms pulses of the 9.25 khz acoustical energy. The pulse rate is detected at the bottom and tuned filters select the proper command. During the one second delay which occurs between the 30 msec transpond pulse and the command burst, the bottom unit will disable the decode function if a command is received. Thus, the proper timing between the transpond pulse and command burst must be maintained or the system assumes that extraneous noise is the cause and will not accept the command.

During the test we found the system extremely difficult to command. A transpond could be initiated from greater than 6,000 feet horizontal distance but commands could only be initiated from certain locations. The best location seemed to be .3 miles east of the buoy on Thursday and Friday and south of the buoy on Monday and Tuesday. The transpond pulse travel time indicated that these locations were not over the capsule. At certain times, we were not able to command the capsule at all. We found that commands with higher burst frequencies could get through when others could not. Thus, the command range was considerably less than the transpond range. Also, spurious transpond pulses at 1.4 sec and 1.9 sec occurred consistently. We thought these transpond pulses were responses to echoes of the command signals. Later, after the capsule

was recovered, we found that this behavior could be caused by increasing the command signal level above some threshold value. Apparently, the receiver can be easily overdriven and will then disregard the command signal. On the ship, the transmitter power was increased until the first transpond reply was heard from the capsule. At that level, commands still could not be initiated. A very slightly higher power setting would cause the echo behavior. Apparently some of the commands were initiated by true command echos though. I believe that this behavior is related to the difficulty in commanding the unit and that it will have to be modified to accept a wider range of input power levels.

Another possible problem was noted when the source level of the bottom projector hydrophone was measured. At the closest range of 1,340 yards, we measured a peak-to-peak amplitude of 5 microbars at the surface. The surface hydrophone and receiver combination had a gain of 0 db relative to one volt per microbar (receiver gain = 6). Correcting for spreading (63 db) and attenuation (4 db) at 13.5 khz, we have

$$L_s = 0 \text{ db} + 63 \text{ db} + 4 \text{ db} + 5 \text{ db} = 72 \text{ db re } 1 \text{ } \mu\text{bar at } 1 \text{ yd.}$$

The EDO specifications claim a source level of 86 db re 1 μ bar at 1 yd., so there is a discrepancy here. In the unusually quiet sea, we measured -26 db re 1 μ bar of acoustic noise over the 3 khz bandwidth of the receiver. This gives us a 31 db signal-to-noise ratio under these conditions. A sea-state of 1/2 and a bandwidth of 3 khz gives an ambient noise level of -33 db according to the EDO Sonar and Transducer Computer. A directivity index of 6 db lowers this to -39 db. It appears that the increased noise we measure

is due to the proximity of the ship. There is probably a constant factor due to ship's generators, etc, and a factor which scales with sea state because of ship's roll, waves breaking against the ship and the usual sea state noise. In fact, one day the sea was rather choppy and small waves (6 to 10 inches high) were breaking but no increase in output noise was observed. Under deep ocean operating conditions, the water depth may be 18,000 feet. The minimum horizontal distance from the capsule which signals must be received from is 18,000 feet. So the range, attenuation and directivity of the hydrophones (45° angle) decrease the signal from bottom to surface by 53 db relative to that measured on our test directly over the package (spreading loss = 79 db, atten, = 23 db, beam pattern loss at 45° = 18 db). At present power level for comparable acoustical noise levels, our signal to noise becomes -22 db. If we assume that all the acoustical noise was from the ship and it doesn't scale with sea state, we achieve a signal to noise of one for a bottom unit source level of 94 db. This fits with the experience of Frank Snodgrass with his deep sea tide capsules, where he finds that the 94 db source level from his bottom projector hydrophones is barely adequate. Thus, it appears that the source level of our bottom acoustical projector will have to be raised to 94 db.

Another portion of the acoustic system is the digital diagnostic transmission. Transmission occurs by encoding 13.5 khz and 15.5 khz as zero and one logic levels. The surface receiver output is passed into a discriminator where output voltage is proportional to frequency. EDO uses a standard Airpax linear discriminator, which proved to be unsuitable for this purpose. First, the 3 khz bandwidth is much larger than necessary since we transmit data at 100 bits per second at only two discrete frequencies. In practice,

the discriminator did not work well at signal-to-noise ratios below 10:1 and we got great improvement by lashing up a tuned amplifier that detected ones and assumed that no signal out was a zero. Ideally, the discriminator should consist of two tuned amplifiers at 13.5 khz and 15.5 khz whose outputs are rectified and subtracted. We plan on making this modification ourselves.

In spite of the discriminator problems, it was possible to get good diagnostics using this scheme. As the slant angle increased, we had some evidence of deterioration due to multipath effects, but when we were almost directly over the package, the transmission and decoding worked beautifully. I am very pleased that this has proven to be straight-forward as it makes diagnostic acquisition extremely simple. It also contributes to our experience in transmitting digital data by means of sonar in the event that it becomes desirable to recover actual data this way.

The Data Logging System

There were no problems with the data logging system. The data plots shown in the figures indicate that real data was recorded. There were no parity errors except where a start logger command was given. This causes the logger to write a record gap without the usual parity bits at the end, so this is expected.

The Acceleration, Tilt Sensors and Analog Electronics

The figures show the six data channels as recorded by the logging system. The two tiltmeter channels and the accelerometer show a 12 hour periodicity that is undoubtedly due to the buoy and line pulling at the instrument at different angles because of ocean currents driven by tides. Leveling and zeroing operations are shown on the figures. Both the recorded data and the diagnostics indicate that the accelerometer, tiltmeter, leveling system, electronics and temperature sensors are working perfectly. The GRAVTEMP sensor was off-scale, so no data was obtained on the accelerometer temperature regulation. However, it can be inferred from the TIDE output that the regulation could not be worse than $.02^{\circ}\text{C}$. This is not a very useful upper limit. For the next deployment, we will probably turn down the gain on this monitor to insure that it stays on scale.

The accelerometer gain was down 40 db from its intended operating value. This was a wise choice, in retrospect, as signals from the buoy would have been too large at higher gain settings.

The accelerometer seems to work fine and IGPP vault tests indicate its intrinsic performance is excellent (ref. A.O.E.L. Report #26). I will

be quite interested to see how it operates on the ocean bottom without a surface buoy attached. The next test will be directed toward this end.

Performance of the Parts Exposed to Sea Water

No apparent significant corrosive action was observed on the pressure housings, releases or aluminum structural members during the four day deployment. Some of the galvanized bolts were slightly corroded and will not be used in critical areas for longer drops.

The package was evacuated to 5 psi prior to loading it on the ship and no water leaks occurred at depth. Connectors, cabling and batteries functioned properly. Unfortunately, a misconnection to both explosive cable cutters prevented a normal release and the package was retrieved with the line to the surface. Upon examination, we found a defect in the vulcanizing of the leads to one of the cutters, causing a 3,000 ohm resistive leak. This kind of defect will not cause a failure unless the wires corrode through. The double firing circuits lessen the chance of this happening. A different kind of connector will be used in the future to make misconnection difficult. Also, the release checklist will include an item necessitating a continuity check through the cables actually used.

Internal Mechanical Structure

There were no mechanical failures inside the package. The gimbal clamping motors and leveling and zeroing motors worked perfectly. As shown by the data, the gimbal system levelled the accelerometer to better than 3×10^{-4} radians (.017 degrees), which is quite adequate for our purposes.

Ship's vibrations caused some electronics mounting bolts to be loosened and several actually dropped out. This could cause problems if they fall to the bottom and activate the leak detector, causing a false release. This will be remedied by using castle nuts wherever possible and lock-tite elsewhere. Also, the leak detector (parallel foil strips which become resistively coupled by the conductive water drops) will be protected so that any bolt or nut that might come loose cannot cause a leak indication. The accelerometer, gimbal and leveling motors showed no ill effects from the rough handling and ship vibration. Vibration isolation mounting pads will be constructed for package transportation in the future.

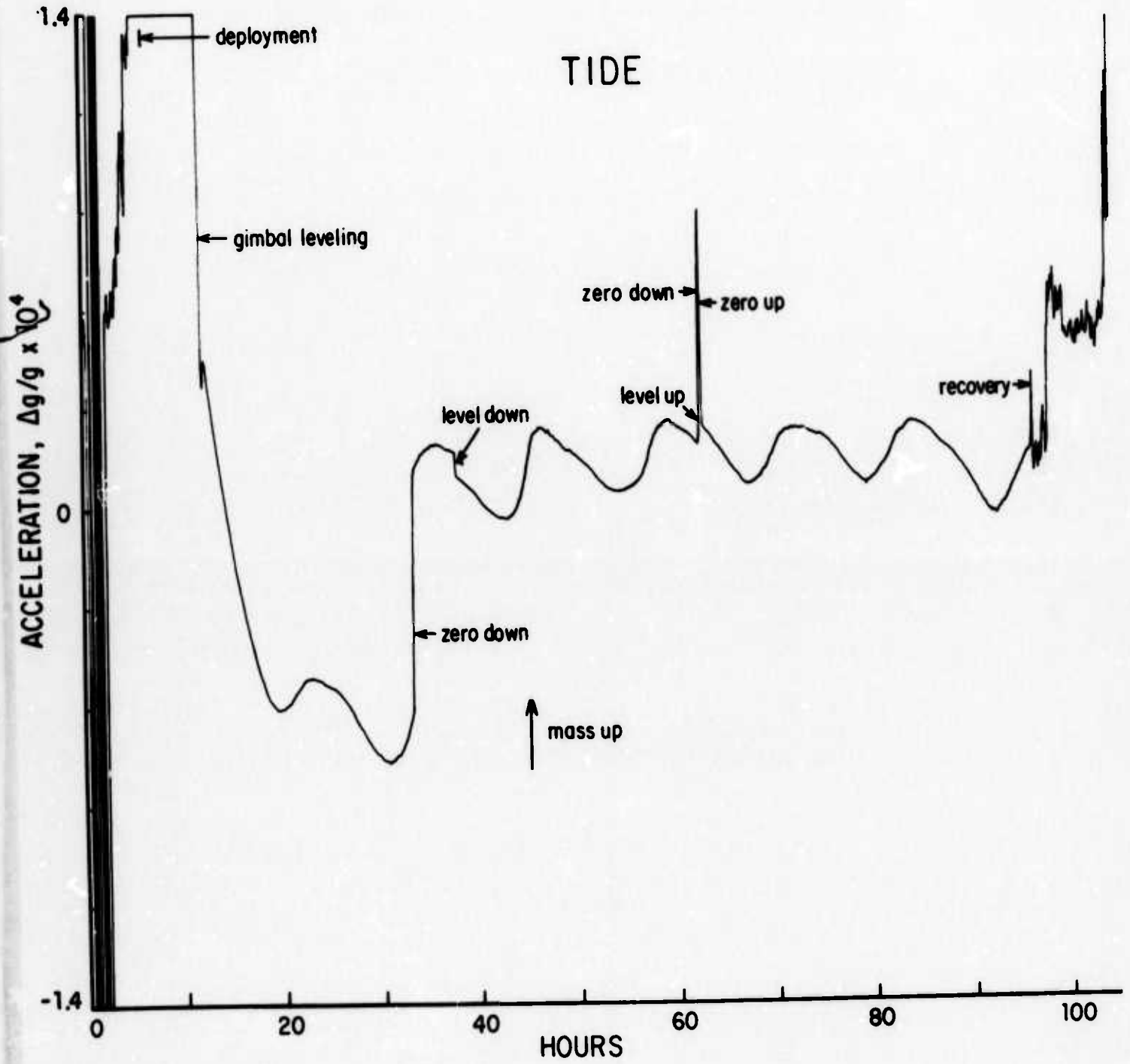

Figure I

TILT 1024

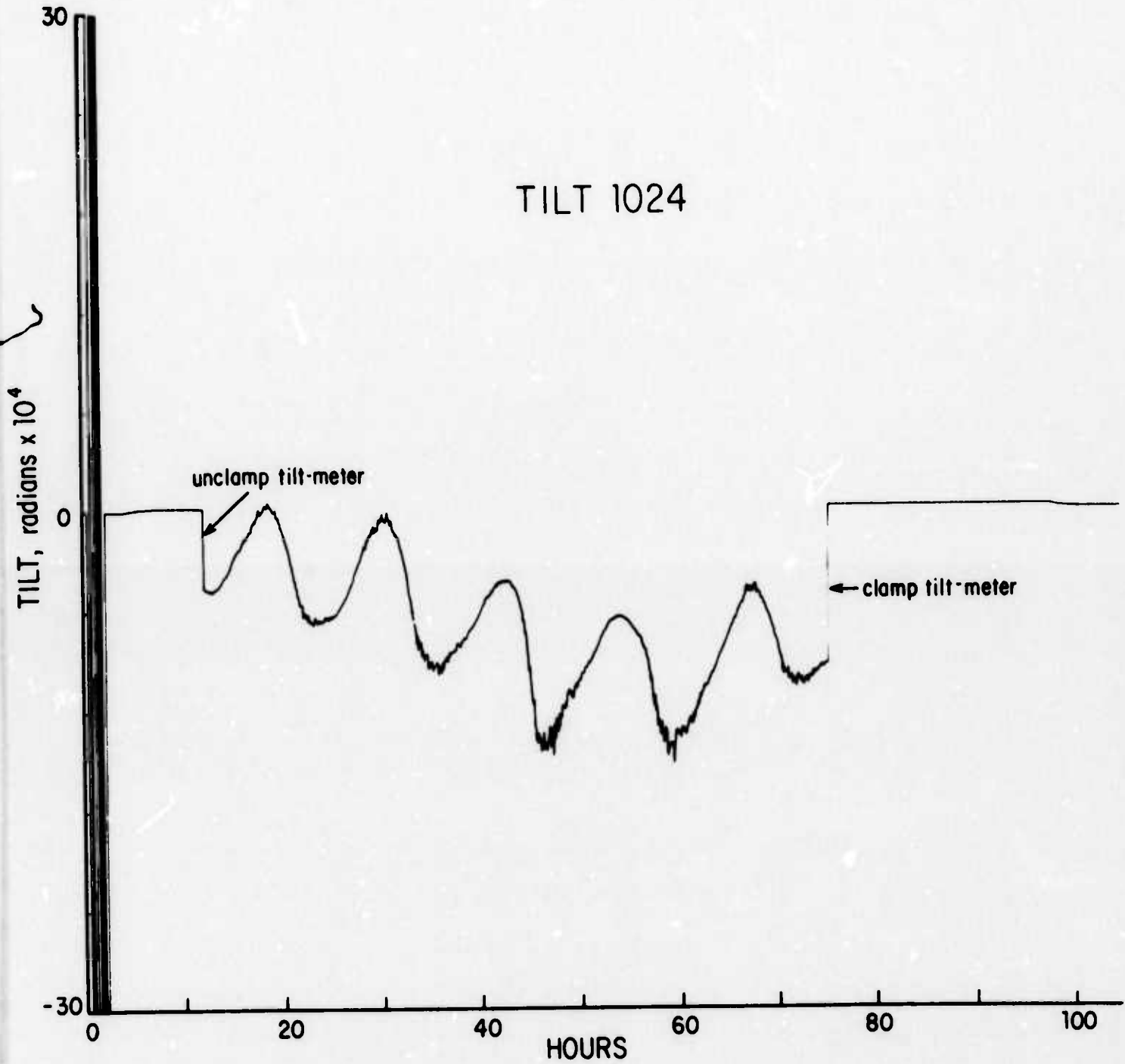

Figure II

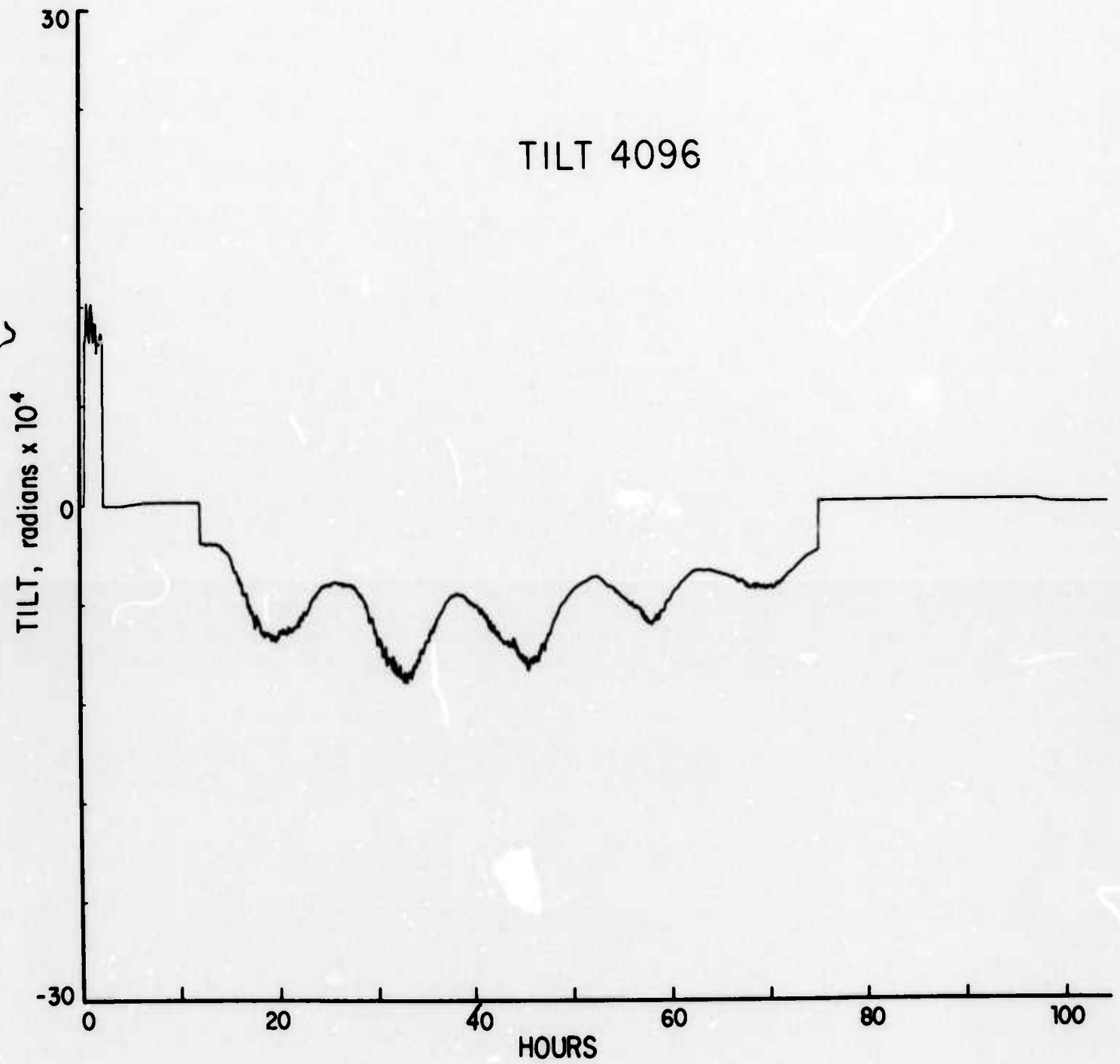

Figure III

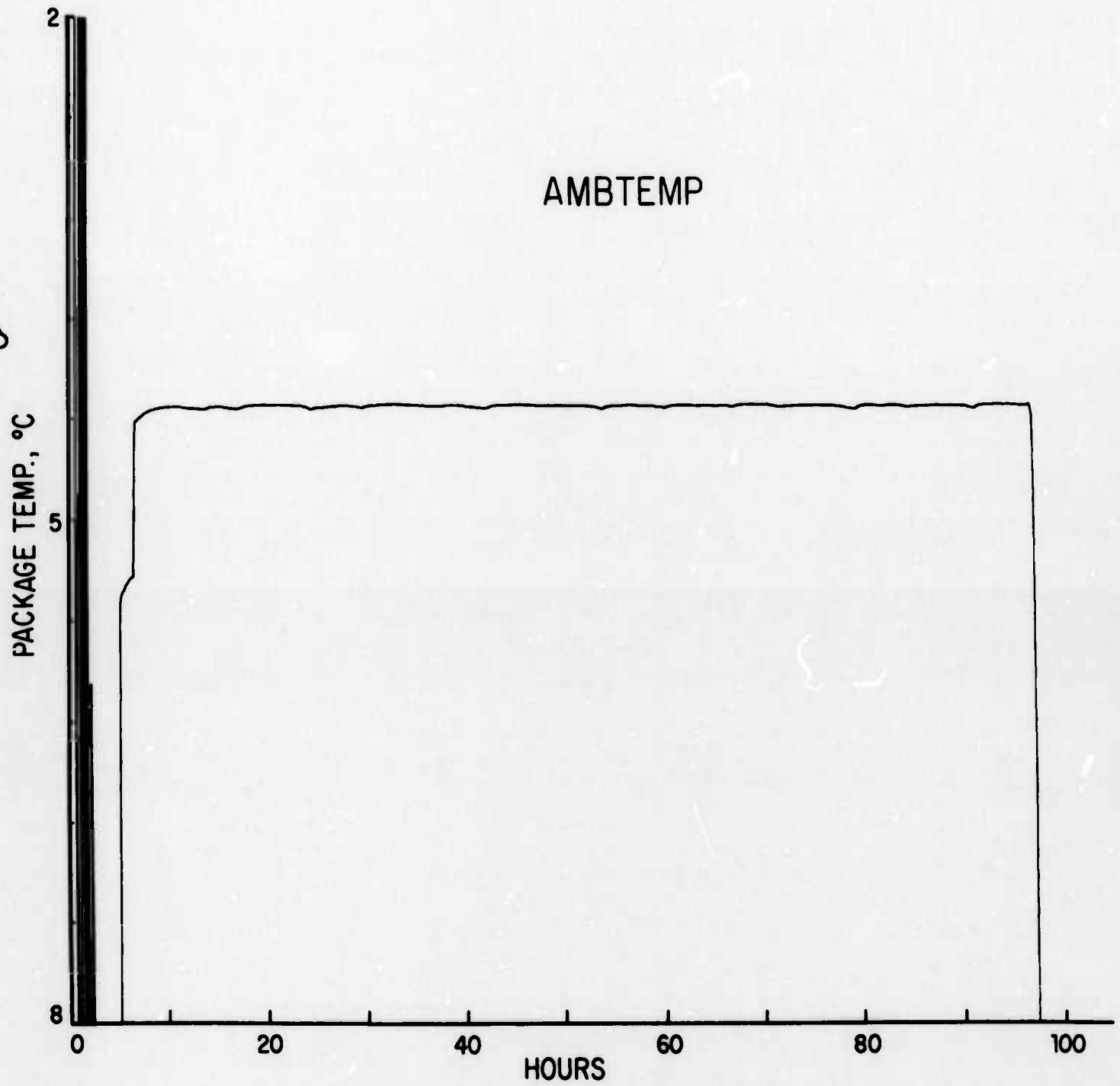

Figure IV

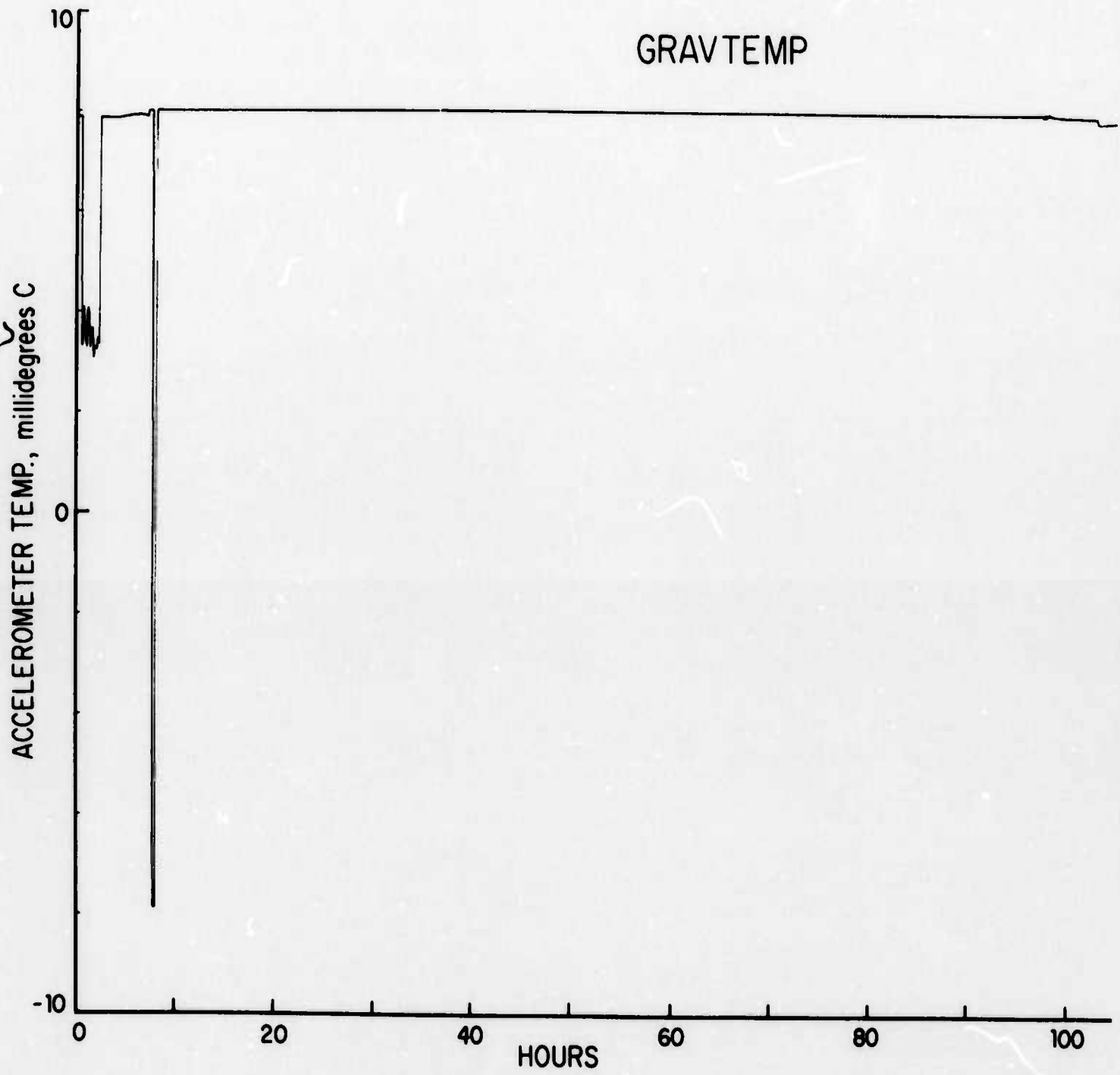

Figure V

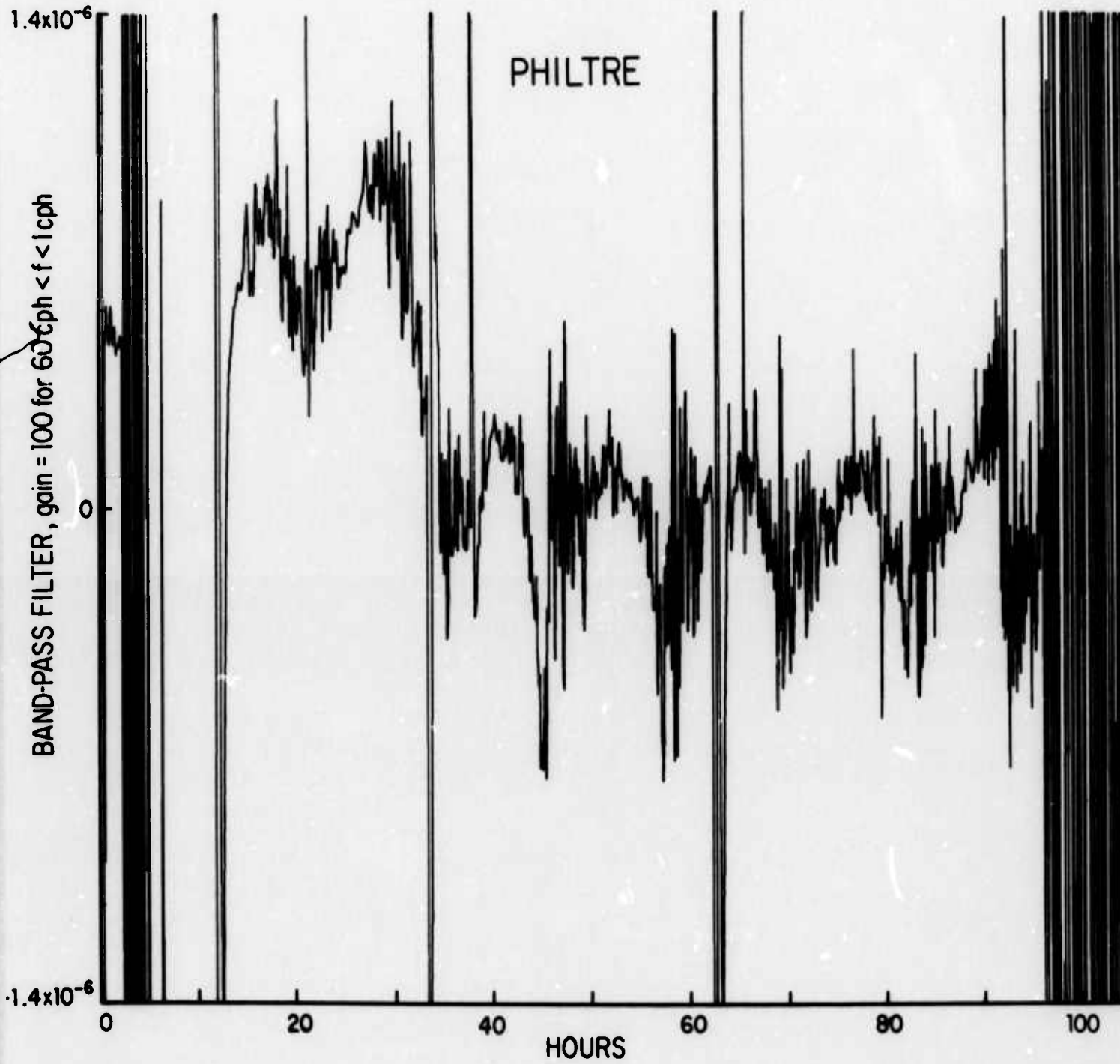

Figure VI

APPENDIX IV

RESULTS OF CINDHI OCEAN DEPLOYMENTS 2 AND 3

William A. Prothero, Jr.

SUMMARY

Deployment 2 was a test of the acoustic command system, release system, and capsule commanded functions. The acoustics and release tests were successful, but a water leak prevented a complete test of all capsule functions. Deployment 3 was intended as a one month package test with data on ocean current speed, vertical acceleration, tilt, and bottom temperature. The RUM/ORB seafloor work system was to be used to perform soil mechanics tests on the bottom and visually observe and photograph the capsule on the bottom. The package performed perfectly except that the accelerometer would not zero. The deployment was terminated after the recovery of the ORB mooring lines caused the capsule to be tipped on its side.

The objectives of deployments 2 and 3 were:

Deployment 2 - Engineering tests

1. ocean test of acoustics modifications
2. capsule release system test (but tethered to a buoy)
3. overall system function tests. Data to be of secondary interest.

Deployment 3

1. one month untethered deployment. Take data on vertical acceleration, tilt, temperature and current speed
2. perform vane shear tests on the bottom sediments near the capsule using the RUM/ORB seafloor work system. Observe and photograph the capsule emplantment using RUM.

Package modifications which were made as a result of deployment 1 are as follows:

1. Send acoustic command system to EDO factory for rebuild according to the results of ocean test 1.
2. Compile package checkout procedures and equipment checklists.
3. Carefully test the package COS/MOS logic circuits for unseen design errors.
4. Install an automatic accelerometer zeroing circuit.
5. Install and interface an ocean current speed transducer to our data logger; transducer to be borrowed from the Munk-Snodgrass Contract.
6. Modify leak detector to release capsule only if a puddle of water is present in the bottom of a sphere. Drops will only give a ping code.

7. Change command channel assignments for greater convenience when difficulty in initiating commands is encountered.
8. Construct cutter to release deployment line from capsule.
9. Construct new package lifting head with swivel.
10. Construct shock mounts for the package to reduce vibration introduced by the ship during transit to the deployment site.
11. Vault test the entire package to determine upper limits on electronics noise and accelerometer noise levels.
12. Cold test the package.

Santa

Test 2 was conducted in 2600 feet of water just south of Catalina Island. The capsule was deployed 7:30 pm July 24 and recovered 2:30 am July 25 (PDT, 1972). The two major successes of the test were the acoustics system operation and the successful commanded release. The acoustic system accepted commands easily. It appears that increasing the dynamic range of the capsule receiver caused this improvement. During the capsule deployment, a low pressure water leak was indicated, but sealed as the capsule depth increased. As the test proceeded, leak codes began to occur in response to transponder interrogations, so the capsule was recovered a few hours sooner than planned. Later, it was found that the o-ring groove of the upper accelerometer hemisphere (previously noted to be marginal) had leaked. The o-ring groove was smoothed and all of the mechanical parts in that sphere were disassembled and cleaned for deployment 3. Deployment 2 was successful enough to warrant the untethered test planned for two weeks later.

Deployment 3 was conducted from the SIO Marine Facilities vessel ORB. ORB is an unpowered buoy with a three point mooring system and center well tracked vehicle for launching RUM, a converted World War II / with a manipulator, search sonar, television and film cameras. The capsule was successfully deployed and tethered to a buoy at 2:50 pm PDT August 5, 1972 in 4200 feet of water just east of San Clemente Island. The acoustic command system worked beautifully the entire time. In fact, every command during the deployment was accepted and executed by the system. Certainly, this perfect record was due to the stability of the ORB mooring nearly over the capsule, but it does indicate that the command receiver is working properly. The digital diagnostic information was easily received and decoded at the surface. Under these

admittedly ideal circumstances, the acoustic communication system worked as well as it did in the lab with connecting cables rather than water as a transmission medium. The source level of the bottom projector was about 5 db higher than for the first deployment, but my calculations show a significantly lower value than EDO claims. Earlier conversations with Gordon Snow at EDO indicated that they may have used a longer cable between the system and the transducer than we did and the unit may be detuned. This should be understood before the deep sea deployment is undertaken.

The problems began after RUM was lowered to the bottom to observe the package. Vane shear tests were successfully accomplished and showed less than .25 psi vane shear strength at 12 inches depth. As ORB was maneuvered using its three mooring lines to position RUM near the capsule, the RUM control cable (to the surface) became tangled in the capsule buoy line. The capsule was located on the RUM search sonar, but the capsule gave gross tilt alert codes, indicating that the RUM cable was tilting it more than 15°. So, RUM was recovered and divers untangled the two lines. At this time, it was decided that there was not enough time to deploy RUM again, as the system had other obligations soon. The ORB crew then began to recover their mooring lines. At 9:40 pm August 6, as we were communicating with CINDHI, transmission stopped abruptly and no further response could be initiated. We hypothesized either an acoustic system failure or some problem caused by the ORB mooring line recovery. On August 8, we returned to the site on the SIO vessel Oconostota and attempted to command a release, which should occur if the bottom projector failed. No release occurred, and the package recovery by the line to the buoy began. As the package was pulled off the bottom, sonar communication was reestablished and a commanded release was achieved. After

recovery, mud was found on the transducers and side of the package, so we concluded that it had been tipped on its side by the ORB mooring line pulling on the CINDHI buoy line. We underestimated the difficulty of working in the vicinity of this many long lines. Had CINDHI been untethered it could have been approached and photographed with no problem. The vane shear tests were most important to the scientific-engineering objective of studying the interaction of the ocean currents with the capsule, so the major objective of the ORB/RUN system was accomplished. Unfortunately the capsule had been tipped over, so had to be recovered. The surface buoy had not been released, so no useful data was taken during the short deployment time. We hope to return to the same site in early December to repeat this test and maintain the same schedule we had set for ourselves earlier, if ships use money permits.

One other problem occurred in the accelerometer. After deployment 2, a small screw inside the inner vacuum can fell out. Thus, a few days before deployment 3, a major dismantling of the accelerometer was undertaken. In the ensuing rush, it was not noticed that the paddle, thus the zero of the accelerometer, had changed its equilibrium position. This change was great enough so that the range of the zero adjustment was exceeded for bottom temperatures. So, there was no accelerometer data. The inner vacuum can must be opened to perform this zero adjustment and with some luck, this operation will go smoothly.

The figures show the sensor outputs as recorded during the capsule deployment. The tilt excursions are three times as large as those measured on deployment 1 in the same area. The gravimeter temperature

control monitor was off-scale as in deployment 1. The vertical lines in the TIDE and PHILTRE plots are artifacts of the computer program used to read the data and should be ignored.

As stated previously, we would like to deploy the package again in the San Clemente Island site, since we know bottom strengths there, so that the interaction between the ocean currents and the package can be studied. Successful completion of this test will enable us to carry out a deep ocean deployment as planned in early 1973.

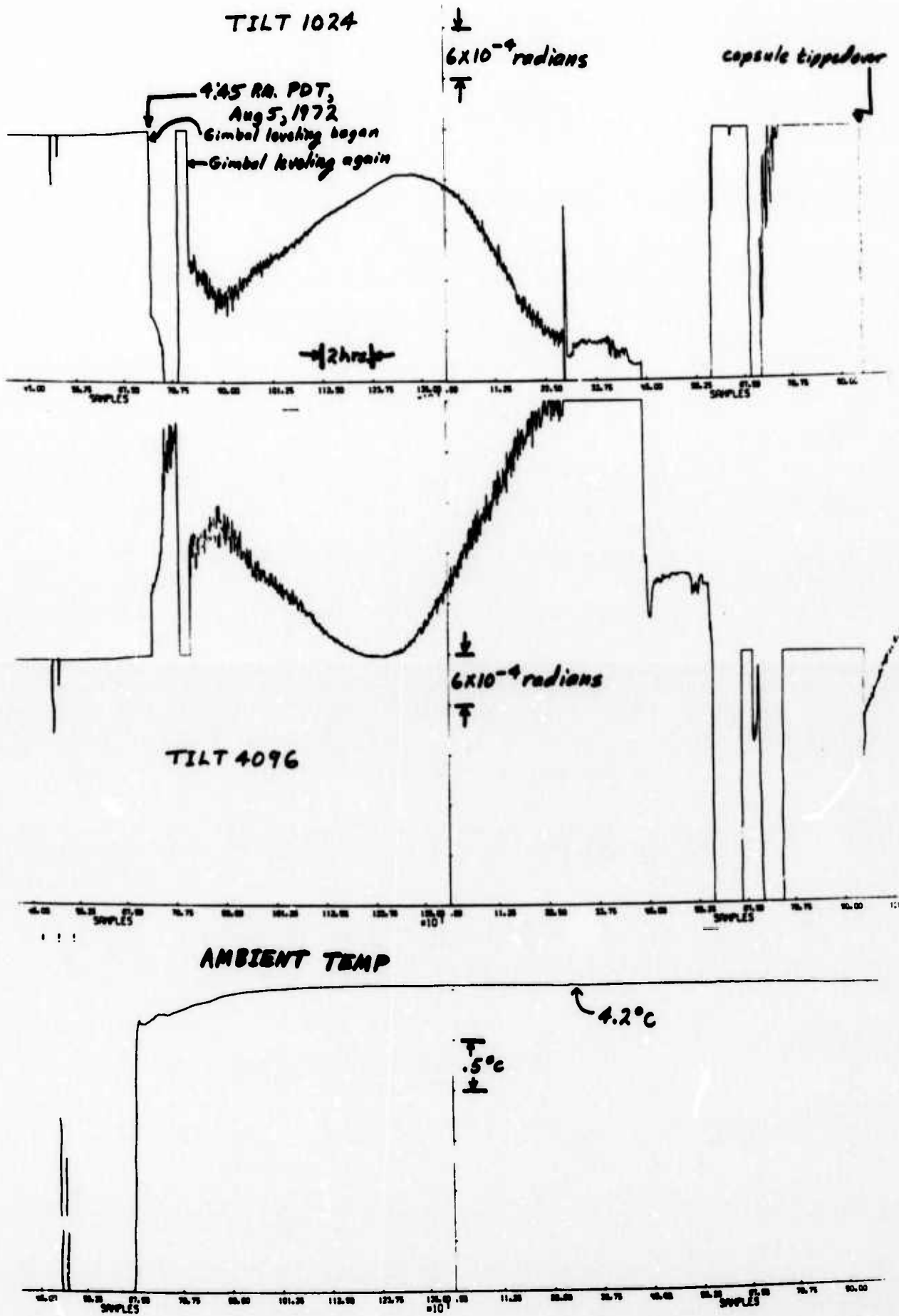

Figure I

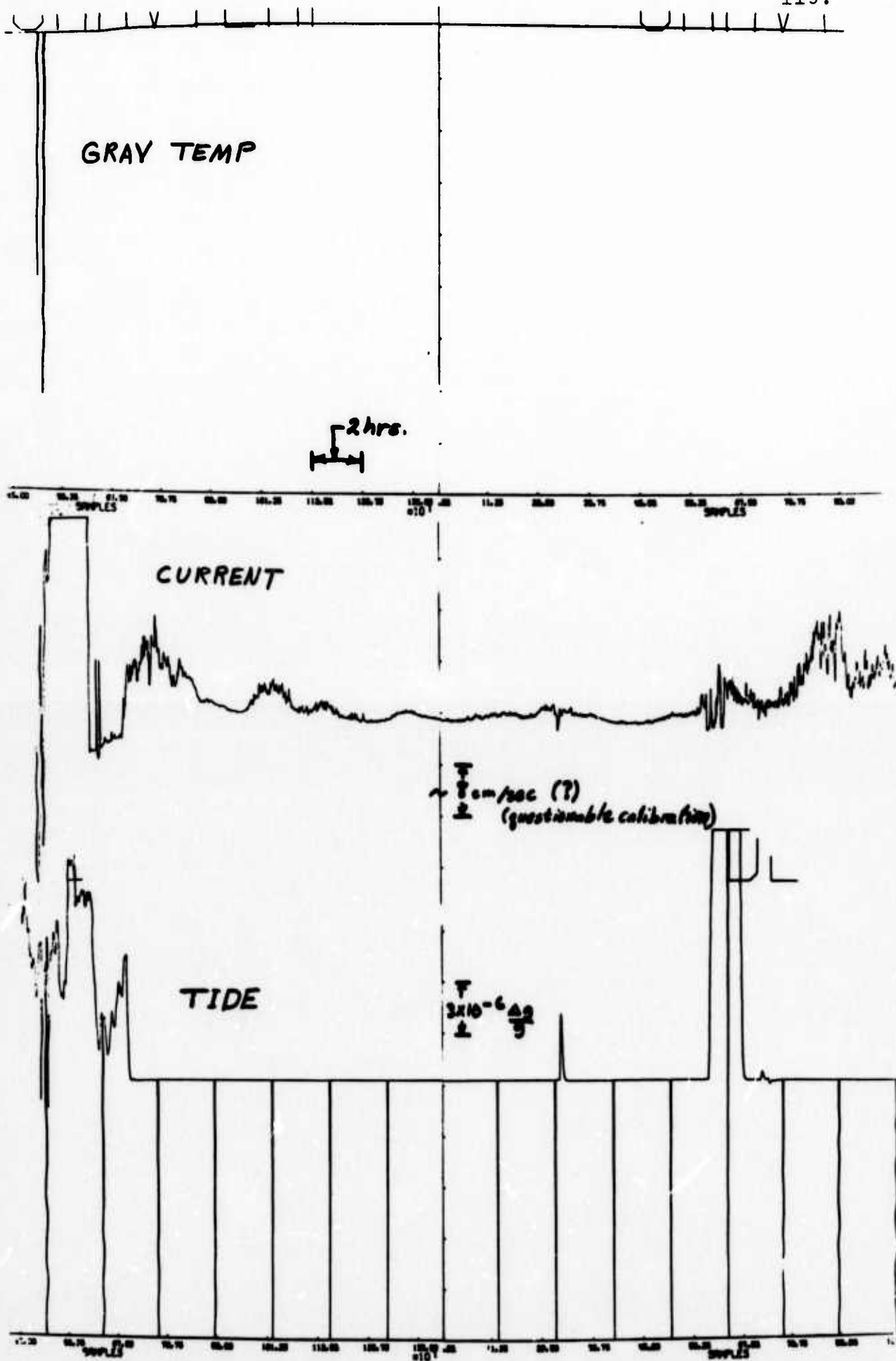

Figure II