

AD-787 333

INVESTIGATION OF INSPECTION AIDS

Richard L. Calhoon, et al

RCA Government and Commercial Systems

Prepared for:

Army Air Mobility Research and  
Development Laboratory

July 1974

DISTRIBUTED BY:

**NTIS**

National Technical Information Service  
U. S. DEPARTMENT OF COMMERCE

Eustis Directorate Position Statement

This investigation is one of a series being conducted on current Army helicopter inspection and maintenance procedures by the Eustis Directorate of the U.S. Army Air Mobility Research and Development Laboratory.

The results of this investigation identify the inspection problem areas and provide guidance for the development of inspection aids which will reduce these problems and make the inspection procedure more effective.

The project engineer for this contract was Mr. William B. Sweeney, Military Operations Technology Division.

ACCESSION for	
NTIS	White Section <input checked="" type="checkbox"/>
DIC	Blue Section <input type="checkbox"/>
UNCLASSIFIED	<input type="checkbox"/>
RESTRICTED	<input type="checkbox"/>
BY _____	
DATE _____	
CONTRIBUTION AVAILABLE TO _____	
BY _____	
DATE _____	
A	

DISCLAIMERS

The findings in this report are not to be construed as an official Department of the Army position unless so designated by other authorized documents.

When Government drawings, specifications, or other data are used for any purpose other than in connection with a definitely related Government procurement operation, the United States Government thereby incurs no responsibility nor any obligation whatsoever; and the fact that the Government may have formulated, furnished, or in any way supplied the said drawings, specifications, or other data is not to be regarded by implication or otherwise as in any manner licensing the holder or any other person or corporation, or conveying any rights or permission, to manufacture, use, or sell any patented invention that may in any way be related thereto.

Trade names cited in this report do not constitute an official endorsement or approval of the use of such commercial hardware or software.

DISPOSITION INSTRUCTIONS

Destroy this report when no longer needed. Do not return it to the originator.

Unclassified

SECURITY CLASSIFICATION OF THIS PAGE (When Data Entered)

AD 787 333

REPORT DOCUMENTATION PAGE		READ INSTRUCTIONS BEFORE COMPLETING FORM
1. REPORT NUMBER USAAMRDL-TR-74-44	2. GOVT ACCESSION NO.	3. RECIPIENT'S CATALOG NUMBER
4. TITLE (and Subtitle) INVESTIGATION OF INSPECTION AIDS	5. TYPE OF REPORT & PERIOD COVERED Final Report 4/18/73 - 5/24/74	
	6. PERFORMING ORG. REPORT NUMBER	
7. AUTHOR(s) R. L. Calhoun, F. W. Hohn, J. A. McNamee, B. B. Wierenga - RCA T. N. Cook, F. E. Stares - KAC	8. CONTRACT OR GRANT NUMBER(s) DAAJ02-73-C-0059	
9. PERFORMING ORGANIZATION NAME AND ADDRESS RCA/Government and Commercial Systems Aerospace Systems Division Burlington, Mass. 01803	10. PROGRAM ELEMENT, PROJECT, TASK AREA & WORK UNIT NUMBERS Task 1F162205A11905	
11. CONTROLLING OFFICE NAME AND ADDRESS Eustis Directorate, U.S. Army Air Mobility Research and Development Laboratory Fort Eustis, Va. 23604	12. REPORT DATE July 1974	
	13. NUMBER OF PAGES 195	
14. MONITORING AGENCY NAME & ADDRESS (if different from Controlling Office)	15. SECURITY CLASS. (of this report) Unclassified	
	15a. DECLASSIFICATION/DOWNGRADING SCHEDULE	
16. DISTRIBUTION STATEMENT (of this Report) Approved for public release; distribution unlimited.		
17. DISTRIBUTION STATEMENT (of the abstract entered in Block 20, if different from Report)		
18. SUPPLEMENTARY NOTES  <div style="text-align: center;"> <small>REPORT OF THE</small>  <b>NATIONAL TECHNICAL</b>  <b>INFORMATION SERVICE</b>  <small>Department of Commerce</small>  <small>Springfield, VA 22151</small> </div>		
19. KEY WORDS (Continue on reverse side if necessary and identify by block number) Inspection X-rays Flexible Scopes Shock Eddy Currents		
20. ABSTRACT (Continue on reverse side if necessary and identify by block number) The investigation of inspection aids was performed to identify specific inspection requirements and recommend relatively small aids or indicators, current or conceptual, that will enhance the troubleshooting inspection/preventive maintenance process for Army helicopters. The study was performed by the RCA Corporation with the participation of the Kaman Aerospace Corporation.		

Unclassified

SECURITY CLASSIFICATION OF THIS PAGE(When Data Entered)

Block 20. Abstract - continued.

Inspection requirements and procedures for six helicopter types (AH-1, UH-1, CH-47, CH-54, OH-6, OH-58) were analyzed. Significant inspections were identified and the effectiveness and adequacy of presently used procedures and techniques was assessed. Areas where the inspector is highly dependent upon subjective judgment or cumbersome or ineffective procedures are employed were determined. Surveys of available off-the-shelf vendor aids and candidate conceptual inspection aids which offer improved inspection efficiency in these areas were performed. Candidate aids were subjected to a feasibility and practicality trial analysis. Applicable inspection aids were evaluated and ranked by two scoring forms which were based on feasibility and cost effectiveness of application.

Results indicate that several available and conceptual inspection aids rate highly for organizational and direct support use in terms of effectiveness, use, cost, device maintenance and application factors. The identified aids provide feasible solutions to 17 specific inspection problems and applications identified by the requirements analysis.

Unclassified

SECURITY CLASSIFICATION OF THIS PAGE(When Data Entered)

## PREFACE

This investigation of inspection aids was performed under Contract DAAJ02-73-C-0059 with the Eustis Directorate, U.S. Army Air Mobility Research and Development Laboratory, Fort Eustis, Virginia. The work was authorized by DA Project 1F162205A119. The study was under the general technical cognizance of Mr. William B. Sweeney of the Military Operations Technology Division. The investigation resulted in the recommendation of several hand-held inspection aids which meet the program's objectives. In addition, many portable instruments are presented which will significantly improve current aircraft inspections. The total report represents a combined survey and design effort of locating inspection aids which will provide a more effective inspection on today's and future Army helicopters.

The inspection aids and instruments described in this report should not be construed to be a complete listing of all manufacturers off-the-shelf applicable devices. The aids and instruments presented are those known by RCA and Kaman Aerospace Corporation investigators to be of above average utility.

TABLE OF CONTENTS

	<u>Page</u>
PREFACE . . . . .	iii
LIST OF ILLUSTRATIONS . . . . .	viii
LIST OF TABLES. . . . .	x
BACKGROUND AND STATEMENT OF THE PROBLEM . . . . .	1
STUDY OBJECTIVES AND APPROACH . . . . .	2
INSPECTION REQUIREMENTS . . . . .	5
DATA BACKGROUND . . . . .	5
INSPECTION PROBLEM SUMMARIES. . . . .	5
INSPECTION AIDS REQUIREMENTS LISTINGS . . . . .	6
CONSOLIDATED MEASUREMENTS MATRIX. . . . .	30
INSPECTION AID EVALUATIONS . . . . .	35
FEASIBILITY EVALUATION . . . . .	35
WESRAC Computer Search . . . . .	35
Vendor Demonstrations . . . . .	36
Plastic Impression Tests. . . . .	39
CANDIDATE FEASIBILITY EVALUATION . . . . .	40
Evaluation Score Sheet . . . . .	40
Feasibility Evaluation Scoring Results. . . . .	42
INSPECTION PROBLEM EVALUATION . . . . .	47
Inspection Problem Evaluation Score Form. . . . .	47
Inspection Problem Scoring Results. . . . .	49
INSPECTION AID EFFECTIVENESS RANKING. . . . .	50
Inspection Aid Ranking Results . . . . .	51

**Preceding page blank**

	<u>Page</u>
INSPECTION PROBLEMS AND APPLICABLE EQUIPMENT . . . . .	54
PROBLEM DESCRIPTIONS, SOLUTIONS AND INSPECTION AIDS. . . . .	54
DEPTH MEASUREMENT - SURFACE DEFECTS. . . . .	54
CRACKS. . . . .	63
Surface Cracks in Nonmetallic Materials . . . . .	65
Surface Cracks in Sheet Metal Structure. . . . .	65
Surface and Subsurface Cracks in Major Structural Components. . . . .	66
Flexible Fiberscopes . . . . .	66
Fluorescent Penetrant Inspection . . . . .	71
Eddy Current Testing . . . . .	79
Ultrasonic Test Equipment. . . . .	93
X-Ray Inspection. . . . .	103
WEAR-ROD END BEARINGS. . . . .	113
BEARING WEAR . . . . .	125
Ultrasonic Translator Detectors. . . . .	124
Temperature Indicating Tabs. . . . .	128
Temperature Indicating Lacquer . . . . .	131
Temperature Indicating Crayons . . . . .	133
Reed Vibrometers . . . . .	134
SLIPPAGE MEASUREMENT-TORQUING. . . . .	139
SLIPPAGE-POSITIONAL MEASUREMENT. . . . .	145
ALIGNMENT MEASUREMENT. . . . .	148
Landing Gear Spread Alignment Check. . . . .	149
Shock Indicators. . . . .	150
FLEXING FAULT DETERMINATION. . . . .	156
DELAMINATIONS/DEBONDS . . . . .	162
Low Frequency Ultrasonic Tester. . . . .	166
Eddy Sonic Inspection . . . . .	168
LEAKAGE . . . . .	171

	<u>Page</u>
External Leakage . . . . .	172
Internal Leakage . . . . .	172
Leak Indicating Tape . . . . .	173
Leak Detecting Paint . . . . .	175
Leak Indicating Powder . . . . .	176
Leak Indicating Pads . . . . .	177
Fluorescent Tracer Additives . . . . .	179
 CORROSION . . . . .	 182
Pitting or Surface Corrosion . . . . .	182
Galvanic Corrosion . . . . .	182
Exfoliation Corrosion. . . . .	183
Fluorescent Oil Method of Corrosion Detection. . .	183
 CONCLUSIONS AND RECOMMENDATIONS. . . . .	 186
SELECTED BIBLIOGRAPHY. . . . .	187

LIST OF ILLUSTRATIONS

<u>Figure</u>		<u>Page</u>
1	Inspection Problem Summary Excerpt . . . . .	7
2	Illustration Excerpt from Inspection Problem Summary. . . . .	8
3	NASA Tech Brief 67-10353 . . . . .	37
4	Feasibility Evaluation Score Sheet . . . . .	41
5	Inspection Problem Evaluation Score Sheet. . . . .	48
6	Scratch Depth Gage. . . . .	61
7	FS-100 Fiberscope . . . . .	69
8	Peeperscope, Model PS-3-18 . . . . .	70
9	Typical Fluorescent Penetrant Containers . . . . .	75
10	Cordless Black Light, M-16 Blak-Ray. . . . .	77
11	Cordless Black Light, Blak-Ray ML-49 . . . . .	79
12	Nortec Eddy Current Instrument. . . . .	82
13	Magnatest ED-520 Eddy Current Instrument . . . . .	84
14	Multitest EM-1500 Eddy Current Instrument. . . . .	86
15	Multitest EM-3100 Eddy Current Instrument. . . . .	88
16	Defectometer Eddy Current Instrument . . . . .	90
17	Audio Probe Eddy Current Instrument. . . . .	92
18	Sonoray Ultrasonic Flaw/Thickness Tester . . . . .	97
19	USM2 Ultrasonic Flaw Detector. . . . .	99
20	Vest-Pack Ultrasonic Flaw Detector . . . . .	101
21	Ultrasonic Reflectoscope. . . . .	102
22	Flexitron Portable X-Ray Unit . . . . .	106
23	SPX 120KV Portable X-Ray System. . . . .	108
24	SPX 160KV Portable Air Cooled X-Ray Unit . . . . .	111
25	Baltospot Portable X-Ray Unit. . . . .	112
26	OH-58 Tail Rotor Control System. . . . .	115

<u>Figure</u>	<u>Page</u>
27 OH-6 Collective Controls. . . . .	116
28 Rod End Bearing Wear Pin Installation . . . . .	117
29 Linear Displacement Sensor. . . . .	119
30 Rod End Bearing Play Sensor . . . . .	120
31 Fotonic Sensor-Optical Proximity Detector . . . . .	123
32 Ultrasonic Translator Detector. . . . .	127
33 Temperature Indicating Tabs. . . . .	130
34 Temperature Indicating Lacquer. . . . .	132
35 Temperature Indicating Crayon . . . . .	134
36 Reed Vibrometer, Korfund Dynamics Corporation . . . . .	136
37 Reed Vibrometer. . . . .	138
38 Major Elements of Tell-Torq Bolt. . . . .	141
39 Tell-Torq Indicator - Inspection Conditions . . . . .	142
40 Photoelastic Strip Tension Bolt . . . . .	145
41 Temperature/Slippage Indicator Label. . . . .	147
42 Landing Gear Spread Measurements. . . . .	149
43 Shock Indicator Location. . . . .	151
44 Humphrey Incorporated Accelograph . . . . .	153
45 "G" Dot Shock Indicator. . . . .	154
46 Shock Overload Indicator. . . . .	156
47 Model 330 Vibration Analyzer Dynamic Balancer . . . . .	158
48 Reed Vibration Instrument. . . . .	161
49 Reed Instrument Diagnosis - Main Rotor. . . . .	163
50 Reed Instrument Diagnosis - Tail Rotor. . . . .	164
51 Reed Instrument Diagnosis - TR Drive Shaft. . . . .	165
52 S-2B Sondicator. . . . .	167
53 Harmonic Bond Tester. . . . .	170
54 Oil Detecting Powder. . . . .	178

LIST OF TABLES

<u>Table</u>		<u>Page</u>
I	OH-6 Aids Requirements Listing . . . . .	9
II	UH-1 Aids Requirements Listing . . . . .	14
III	CH-47 Aids Requirements Listing . . . . .	19
IV	CH-54 Aids Requirements Listing . . . . .	24
V	Consolidated Inspection Requirements . . . . .	31
VI	Plastic Impression Tests. . . . .	40
VII	Problems Versus Inspection Aids Page Reference Chart. . . . .	55
VIII	Landing Gear Spread Specifications . . . . .	150

## BACKGROUND AND STATEMENT OF THE PROBLEM

Preventive maintenance inspections of Army helicopters present a wide variety of inspection requirements and procedures. In completing the prescribed procedures, in many cases, the technical inspector is aided by a measuring device. Usually, however, he is dependent upon his own sensing capabilities in determining the serviceability of the aircraft. Inspection quality is therefore dependent upon the experience, training, opinion and disposition of mind of the individual inspector. The inspection often then is highly subjective in nature.

The past decade has seen notable advancements in helicopter design but no parallel change in the support equipment available to the Army maintenance technician. Inspection and troubleshooting methodology has remained stagnant. Government agencies and industry have applied significant investments in advanced systems for automating the inspection, diagnostic and prognostic processes in mechanical systems. Systems of this type are desirable since they measure and quantify and thus can eliminate or minimize subjectivity. The technology of such systems has not advanced to the point where they can yet be expected to assume total responsibility for inspecting and troubleshooting a machine as complex as an Army helicopter. Also, many inspection requirements are of a nature which can be best accomplished by the human.

Thus, in the near term, Army aircraft inspection/troubleshooting processes are destined to remain inexact and subjective. This situation generates unnecessary (1) maintenance action and parts consumption, (2) maintenance errors with flight safety implication, (3) extended inspection times, and (4) overloading of the logistics system. Surveys of current Army inspection practices in the field have reflected the need for the identification or conceptual development of low-cost, simple, lightweight inspection aids to enhance the inspection process by reducing inspection subjectivity. Implementation of such devices can help simplify and better quantify aircraft inspection.

## STUDY OBJECTIVES AND APPROACH

The objective of the work performed was to identify specific inspection requirements and make recommendations for relatively small inspection aids or indicators, current or conceptual, that will enhance the troubleshooting inspection/preventive maintenance process for Army helicopters. The effort concentrated upon the following:

- Defining inspection aids for areas where the inspector is highly dependent upon subjective judgment.
- Finding small, hand-held types of aids which are applicable at organizational and direct support rather than depot level.
- Locating aids which have a broad application (i.e., to many aircraft types and/or to many inspection requirements on a single aircraft type).

Initial analysis involved identifying significant inspection requirements and procedures in which measuring devices are applied and those requirements which are accomplished without the assistance of an inspection aid for six helicopter types (AH-1, UH-1, CH-47, CH-54, OH-6, OH-58). Areas where the inspector is highly dependent upon subjective judgment were identified and the effectiveness and adequacy of presently used inspection aids was assessed. Aids requirements for each aircraft type were then listed. For each type, the parameter to be inspected, measurement tolerances and checklist and TM References were listed. A master matrix was also prepared which consolidates the measurement types and ranges for each of the six aircraft types into one reference chart.

The second step of the analysis involved identification of candidate inspection aids for improved quantification and effectiveness in the problem areas. Surveys of available off-the-shelf vendor items applicable as candidate problem solutions were made through search of the RCA and Kaman Engineering Libraries and through vendor contact. In a parallel effort, RCA and Kaman Engineering personnel identified

candidate conceptual inspection aids which offer improved inspection efficiency. During the initial analysis, it became apparent that previous work performed by industry and Government agencies in the areas of nondestructive testing was applicable. The Western Research Application Center (WESRAC) of the University of Southern California was therefore employed to perform a computer search to isolate relevant literature. WESRAC provided useful additional candidate inspection aids and techniques early in the identification process.

Once the definition process for conceptual designs, developmental projects and off-the-shelf aids was completed, a feasibility and practicality trial analysis was performed. This process involved vendor hardware demonstrations, trials of off-the-shelf aids on actual aircraft by engineering personnel and engineering evaluation of advanced inspection techniques. (Actual demonstration and trial of all aids/devices/instruments was not possible due to program constraints.) Those inspection aids which were judged applicable toward meeting the basic objectives of this program were then subjected to a feasibility/application scoring evaluation. The aids which were similar and used the same operating principles were evaluated as a group. All groups/candidates were scored using a weighted multiplier method based on the following factors:

- Weight and Size (hand held)
- Operation ease
- Simplicity
- Cost (inexpensive)
- Multiplicity of application (different aircraft)
- Training required
- Dexterity required
- Reduction in inspection subjectivity
- Multiplicity of application (maintenance levels)
- Maintainability and Reliability

Analysis of these scores and the aid description write-ups then led to recommendations of those aids which will most enhance the troubleshooting inspection/preventive maintenance process.

The final step in the analysis involved a cost effectiveness evaluation of application of recommended aids. This analysis utilized the results of the feasibility scoring evaluation. A

similar scoring scheme was used to perform a comparison cost of application of recommended aids. Variables for cost on an aircraft company basis along with factors for training, skill, repair time and spares costs were included. This evaluation resulted in a ranking of aids from a cost and effectiveness of application viewpoint.

## INSPECTION REQUIREMENTS

### DATA BACKGROUND

Data used in the generation of these inspection requirements was largely derived from basic information related to present inspections of six aircraft types (AH-1, UH-1, CH-47, CH-54, OH-6, OH-58). A data review was conducted to determine which inspection tasks provide the most fruitful areas for improvement through application of simple aids. The data used included data assembled under earlier helicopter inspection studies\* which define inspection problem areas for the six helicopter types and the presently applicable scheduled inspection checklists and technical manuals. The review considered those requirements and procedures in which measuring devices are applied and those requirements and procedures which are accomplished without the assistance of such a device. In addition, the effectiveness and adequacy of the inspection aids presently utilized was assessed.

### INSPECTION PROBLEM SUMMARIES

As the first step in the analysis, inspection problems which were uncovered in the two earlier studies through analysis of maintenance histories and field work were reanalyzed and summarized. These summaries provided concise information which was used as an important input in the definition of the inspections of significance to this study (later defined in the Aids Requirements Listings for each aircraft type). For each of the problems summarized, the component in question and its location were described, inspection requirements and methods

- 
- \*1. "Analysis of Army Helicopter Inspection Requirements," USAAMRDL Technical Report 72-35.
  2. "Helicopter Inspection Design Requirements," USAAMRDL Technical Report 73-22.

and possible deficiencies involved were defined, and the inspection frequency and any equipment and/or materials required in the inspection were listed. Pertinent illustrations from Technical Manuals which help make the problems more understandable were also referenced. Figures 1 and 2 are related excerpts from the tabular inspection problem summary illustrating the format and type of data included.

### INSPECTION AIDS REQUIREMENTS LISTINGS

After the problem area review and summarization, an engineering analysis of the inspection requirements and procedures for each of the six helicopter types was performed. Each checklist and the supporting technical manuals were given a step-by-step review to determine how the inspection requirements are completed (with or without inspection aids), and to estimate the effectiveness of each inspection. Those inspections which present opportunities for improvement due to limitations of a measuring device presently used, access problems, excessive time consumption, or requirements for subjective judgment on the part of the inspector were determined. This group of inspection requirements was then categorized in terms of the measurement characteristics involved (depth, wear, etc). An aids requirements listing for each aircraft type was then completed. This listing shows the types of measurements required, the components within the aircraft which require such a measurement, and the tolerances for each measurement. Checklist and technical manual references which define present inspection requirements and procedures are also noted. This listing, then, provides a digest of those inspections for each aircraft which warrant study for future application of new or improved inspection aids. The aids requirements listings for four of the six helicopter types were found to be deterministic of the spectrum of total requirements. The listings for the four helicopters are presented in Tables I through IV. They respectively include an observation helicopter (OH-6), a utility helicopter (UH-1), a medium lift helicopter (CH-47), and a heavy lift helicopter (CH-54). All dimensions listed are in inches unless otherwise noted.

Information on these listings is organized by defect type in the following order.

- Depth
- Wear

INSPECTION PROBLEM SUMMARY

Helicopter Model: CH-47

Aircraft System: Flight Controls

Item No.	Item Description and Location	Inspection Requirement (Modes, Conditions, Tolerances)	Current Inspection Method Deficiencies	Insp Freq	Equipment and Materials
14-3	<p>Connecting Links P/N 114C3327-21. A corrosion resistant steel tube, to which rodends with dry-type bearings are secured via a turn-buckle. The link, transfer control motions to and from the control mixing assembly. Access is via the closet controls access panels.</p>	<p>Bearing Wear. Axial play between rodends and the bell crank lug should be less than 0.010 inches. Radial play on anti-friction bearings should be less than .0004 inches. Radial play on dry-type bearings should be less than 0.007 inches. Ref. PMP, 6.7, 6.28.</p>	<p>Looseness is measured either by feeler gage or dial indicator. Ref. -20 T.M., para. 9-18.</p>		<p>Feeler gage Dial indicator</p>

Figure 1. Inspection Problem Summary Excerpt.

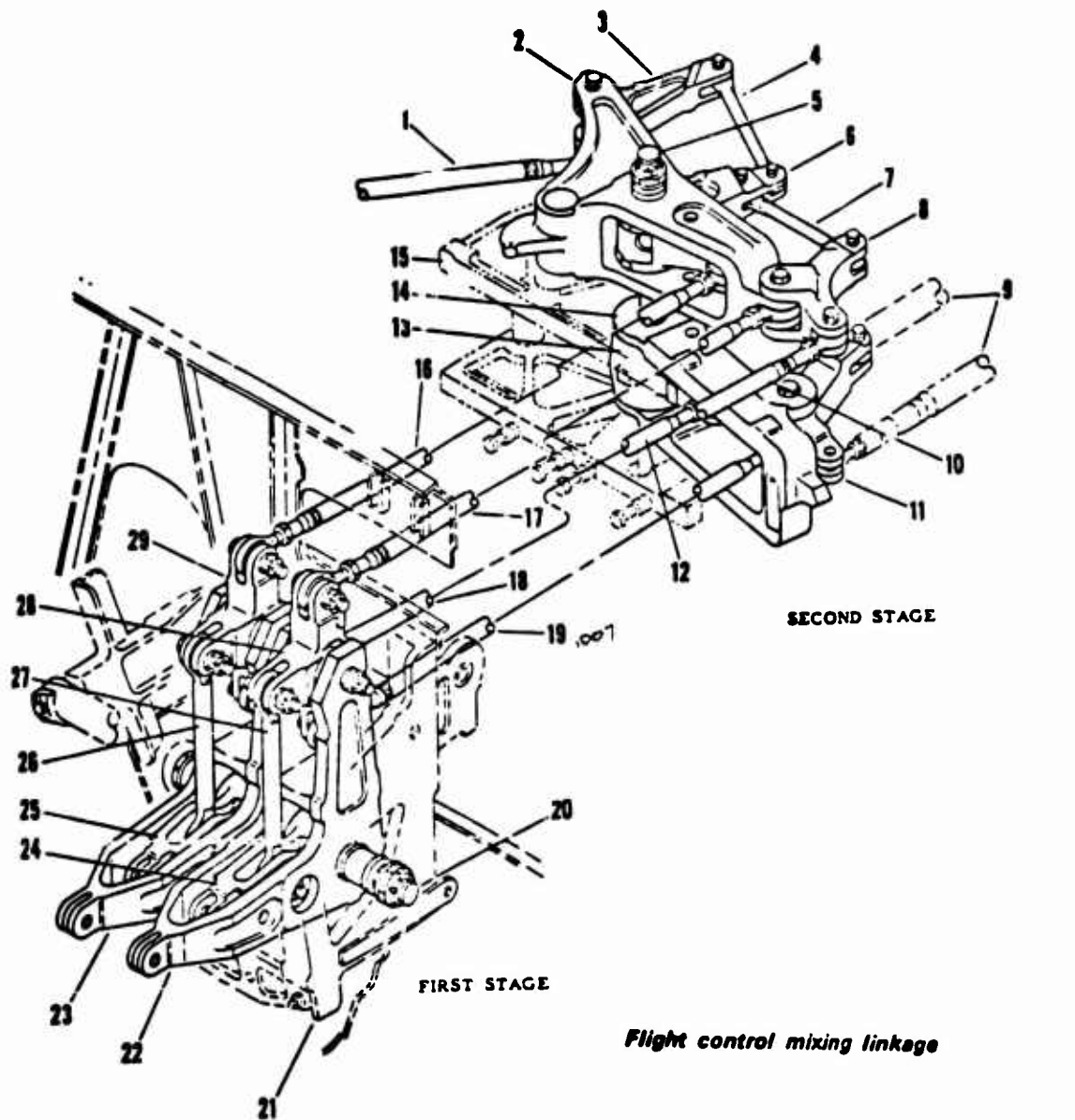

- |   |   |  |
|---|---|--|
| <ul style="list-style-type: none"> <li>1. Forward upper connecting link</li> <li>2. Forward support bellcrank</li> <li>3. Forward right output bellcrank</li> <li>4. Nonadjustable connecting link</li> <li>5. Support assembly and shaft</li> <li>6. Forward input bellcrank</li> <li>7. Nonadjustable connecting link</li> <li>8. Forward left output bellcrank</li> <li>9. Forward tunnel connecting links</li> <li>10. Forward upper connecting link</li> <li>11. Aft output bellcrank</li> <li>12. Lower inboard adjustable connecting link</li> </ul> | <ul style="list-style-type: none"> <li>13. Aft input bellcrank</li> <li>14. Aft support bellcrank</li> <li>15. Support structure</li> <li>16. Upper inboard adjustable connecting link</li> <li>17. Upper outboard adjustable connecting link</li> <li>18. Lower inboard adjustable connecting link</li> <li>19. Lower outboard adjustable connecting link</li> <li>20. Support shaft</li> <li>21. Support structure</li> </ul> | <ul style="list-style-type: none"> <li>22. Yaw and support bellcrank</li> <li>23. Thrust and support bellcrank</li> <li>24. Roll input bellcrank</li> <li>25. Pitch input bellcrank</li> <li>26. Pitch and thrust nonadjustable connecting link</li> <li>27. Roll and yaw nonadjustable connecting link</li> <li>28. Roll and yaw output bellcrank</li> <li>29. Pitch and thrust output bellcrank</li> </ul> |
|---|---|--|

Figure 2. Illustration Excerpt from Inspection Problem Summary.

TABLE I. OH-6 AIDS REQUIREMENTS LISTING

Defect Type and Requirement	References	
	Checklist	-20TM
<u>Depth</u>		
1. Landing Gear Skids	2.1	4-59
- Scratches - 0.015 max (after repair)		
- Dents - 0.020 max		
2. Droop Stop Striker Plates	2.20	9-3
- Brinelling 0.030 max		
3. Main Xsmn Drive Shaft	2.4	7-4
- Dents 0.015 max		
4. Main Rotor Blade	2.13	8-4
- Scratches 0.001-0.025 max		
- Dents 0.095-0.250 max		
5. MR Hub		
- Scratches - 0.10 max	2.13	8-7
6. - MR Blade Trailing Edge Bond	2.14	8-4
- Separation 0.500 max		
7. TR Blade Abrasion Strip Binding	4.9	8-9
- -0.05 max		
8. TR Blade	4.9	8-9
- Scratches - 0.005 max		
- Scratches - 0.010 max		

Table I - Continued

Defect Type and Requirement	References	
	Checklist	-20TM
<u>Wear</u>		
1. Skid Tubes	2.1	4-59
2. TR Drive Shaft - Excessive wear in damper area	3.6	7-11
3. Starter-Generator - Check brushes ... Replace generator if remaining allow- able wear might be exceeded before next scheduled inspection	5.10	12-9
<u>Rod-End Play/Looseness</u>		
1. Cyclic, Collective, TR Controls - 0.040 max axial looseness	1.25, 2.3, 2.10	9-5, 9-11, 9-12, 9-13, 9-14, 9-21
2. Skid Tube Pivot Bearings - 0.040 max axial looseness	2.1, 5.1, 6.1	4-59
3. MR Damper Arm Bearing - 0.015 max radial play	2.13	8-4
4. MR Vibration Absorber Hinge Pins - 0.015 max radial play - 0.085 max axial play	2.13	8-5
5. MR Pitch Bearing - 0.010 max radial looseness Ball and pin assemblies	2.19	8-9 (-35)

Table I Continued

Defect Type and Requirement	References	
	Checklist	-20TM
6. MR Damper Arm Bearings	2.22	8-7
- 0.010 max radial play		(-35)
- 0.020 max axial play		
7. Pitch Control Link Bearings	4.7	8-9
- 0.020 axial looseness		
8. TR Fork Bearing	4.7	8-9
- Max radial looseness 0.008		
9. Engine Control Rod End Bearings	5.6	
- Max axial looseness 0.040		
<u>Cracks</u>		
1. Landing Gear Ground Handling Fittings	2.1	4-59
- Cracks		
2. TR Pedal Brackets and Bell Crank Support for Cracks	1.26	9-19
3. Flight Control Bell Cranks	2.3	9-6
4. Main Xsmn Drive Shaft	2.4	7-4
5. Main Xsmn Case	2.9	7-7
6. TR Drive Shaft	2.9	7-11
7. MR Blade	2.13	8-4
8. MR Hub and Links	2.13, 2.15	8-7
9. MR Pitch Housing	2.16	8-7
10. MR Damper Arm and Clevis	2.23	8-8
11. MR Retention Strap Packs	2.24	8-6 (-35)
12. MR Support Fittings and Structure	2.25	4-45
13. Keel Beam	2.28-1	--

Table I - Continued

Defect Type and Requirement	References	
	Checklist	-20TM
14. Tail Boom Attach Points	3.1	4-53
15. Horiz & Vert Stabilizer Attach Fittings	4.1	4-54
16. Tail Skid & Attach Fitting	4.2	--
17. Tail Rotor Xmsn	4.5	7-13
18. TR Blade	4.9	8-9
19. Landing Gear Skid Tubes	6.i	4-59
<u>Torquing</u>		
1. Tail Boom Attach Bolts - 190-240 in.-lb	3.1	4-53
2. Main Xsmn - 60-80 in.-lb	2.9	7-7
3. Main Rotor Damper Assembly - 300-325 in.-lb (-35 TM) (-20 TM says 265-385 in.-lb)	2.22	8-7 (-35) 8-8 (-20)
4. Main Rotor Mast Holddown Bolts - 700-820 in.-lb	2.25	7-9 (-35)
5. Horizontal Stabilizer Attach Bolts - Forward 50-70 in.-lb - Aft 380-410 in.-lb	4.1	4-28 (-35)
Upper Vert Stabilizer Attach Bolts - Forward 50-70 in.-lb - Nuts 170-200 in.-lb	4.1	4-29 (-35)
Lower Vent Stabilizer Attach Bolts - 25-40 in.-lb	4.1	4-30 (-35)
6. Tail Rotor Xmsn Attach Bolts - 50-70 in.-lb	4.5	7-12 (-35)

Table I - Continued

Defect Type and Requirement	References	
	Checklist	-20TM
7. Engine Lift Fitting	5.4	5-10
- Side bolts 140-160 in.-lb		(-35)
- Front bolt 160-190 in.-lb		
<u>Slippage</u>		
Between Pitch Control Inner Race and Swashplate	4.8	8-9
<u>Extension</u>		
Landing Gear Front Shock Dampers	2.2 5.1 6.2	4-60
<u>Tail Rotor Drive Shaft Deflection</u>		
TR Damper	3.5	7-12
- Limit Deflection to 0.50 in. max		
<u>Visual Inspection in Inaccessible Places</u>		
1. Tail-Boom Corrosion (interior)	3.3	4-53
- Borescope		
2. Compression Inlet and Blades for FOD	2.11	5-4
3. Keel Beam for Cracks	2.28.1	-
<u>Metal Particles</u>		
1. Main Transmission Chip Detector	2.7	7-7
2. TR Transmission Chip Detector	4.6	1-28
3. Engine Chip Detector	5.12	5-44

TABLE II. UH-1 AIDS REQUIREMENTS LISTING

Defect Type and Requirement	References		
	Checklist	-20TM	-35TM
<u>Depth</u>			
1. Skid Tubes	2.2	4-288	
Scratches 0.03			
Dents 0.25			
2. Main Rotor Blades	4.1	8-32	
0.008-0.120			
3. MR Hub Assembly	4.1	8-38	
0.010-0.060			
4. Stabilizer Bar	4.2	8-46	
0.010 maximum			
5. Engine Mount Rods/Braces	5.9	5-39	
0.010 maximum			
6. Tail Rotor Drive Shaft	6.3	7-115	
0.002-Area A - 0.004-Area B			
0.008-Area A - 0.012-Area B			
0.010-Area A - 0.020-Area B			
7. *Aluminum TR Drive Shaft Clamps	6.3	7-117	
0.008 Internal V			
0.010 External			
8. Tail Rotor Hub Assembly	6.6	-	8-54
0.005-0.010			
0.002 Corrosion			
9. Synchronized Elevator Controls	6.8	9-78	
0.010		(8-73)	

\*Access Problem

Table II - Continued

Defect Type and Requirement	References		
	Checklist	-20TM	-35TM
<u>Wear</u>			
1. *Skid Shoes Unserviceable due to damage or wear	2.2	4-288	
2. *Collective Friction Liners 0.005 above rivets (Depth Measurement)	2.11	9-15	9-5
3. Tail Rotor Drive Shaft Bearings Roughness (Feel Test)	6.3	7-123	
4. *Tail Rotor Pitch Control (Chain Elongation)	6.7	9-64	
5. Tail Rotor Cable Installa- tion (Cables for broken wires and proper tension) (Pulleys for flat spots, worn bearings, etc)	6.9	9-71	
6. Tail Rotor Drive Shaft Couplings (Visual check of splines)	6.10	-	17-16
<u>Bearing Play/Looseness</u>			
1. Cyclic and Collective Control Cylinders Retainer (P/N 100621 or 100621-1)	3.4 -	6-63 6-74	- -
<b>*Access Problem</b>			

Table II - Continued

Defect Type and Requirement	References		
	Checklist	-20TM	-35TM
2. Stabilizer Bar Bearings	4.2	8-46	
<u>Brng</u> <u>Radial</u> <u>Axial</u>			
BR5R	0.007	0.010	
KP6A	0.010	0.010	
310-1	0.012	0.005	
Damper Link	} 0.012	0.012	
Pitch Change Link U			
Pitch Change Link U	} 0.0085	0.017	
Pitch Change Link RE			
Pitch Change Link RE	} 0.010	0.010	
Pitch Change Link RE			
3. Swashplate/Gimbal Assembly	4.5	8-59	
<u>Brng</u> <u>Radial</u> <u>Axial</u>			
Gimbal Ring	} 0.010		
All Trunnions			
Trunnion Brng	-	0.020	
Trunnion Brng	} 0.020	0.020	
Trunnion Brng			
4. Synchronized Elevator Control Binding, Chattering, Excessive Looseness	4.6	9-78	
5. Engine Mount	5.9	5-39	
<u>Brng</u> <u>Radial</u> <u>Axial</u>			
Trunnion Rod End	0.006	0.012	
Rod End	0.005	0.022	
6. Tail Rotor Assembly	6.6	8-81B (9-67)	
<u>Radial</u> <u>Axial</u>			
0.020-0.035	0.020-	0.018	
0.035			
7. *Synchronized Elevator Controls	6.8	9-78	

\*Access Problem

Table II - Continued

Defect Type and Requirement	References		
	Checklist	-20TM	-35TM
<u>Cracks</u>			
1. Cabin Exterior Skin	2.1		
2. *Cabin Structure	2.10		
3. Cabin Bottom	2.15		
4. Breakaway Valves	3.1A		
5. *Oil Cooler, Duct, etc. Attachment Points	3.3		
6. External Stores Installation	3.6		
7. Engine Deck	3.7		
8. Stabilizer Bar Outer Tubes	4.3		
9. *Swash Plate Inner Ring	4.5		
10. Pylon Mount Supports and Lift Link Beam	4.13		
11. Engine Inlet Housing	5.3		
12. Engine Compressor Housing	5.7		
13. Engine Combustion Chamber	5.8		
14. Engine Mounts	5.10		
15. Accessory Gearbox Flanges	5.24		
16. Overspeed Governor and Tach Drive Flanges	5.25		
17. *Tail Boom Structure	6.1		
18. *Tail Boom Attachment Fittings	6.2		
19. Tail Rotor Drive Shaft Clamps	6.3		
20. *Synchronized Elevator Control	4.6	9-78	
21. Compressor Housing	5.7		5-224
22. Combustion Chamber	5.8		5-294
23. Exhaust Diffuser			5-303
24. Tail Pipe		5-142	
*Access Problem			

Table II - Continued

Defect Type and Requirement	References		
	Checklist	-20TM	-35TM
25. Engine Mount Bearings	5.9	5-39	
26. Tail Rotor Drive Shaft Couplings	6.10		
<u>Torque/Slippage</u>			
Tail Boom Attachment Fittings	6.2	4-254	4-137
770-950 in.-lb (Upper)			
240-270 in.-lb (Lower)			
<u>Leaks</u>			
1. Fuel Supply Lines	3.1		
2. Hydraulic Cylinders & Supply Lines	3.4		
<u>Extension</u>			
Landing Gear	2.2	4-288	
100in. max spread			
48/50 in. Tube/CL			
<u>Alignment</u>			
Drive Shaft Hanger & 42 <sup>o</sup> Gearbox - (Fixture and Wire Method)		-	F 17-8
<u>Metal Particles</u>			
Gearboxes	4.11		
(Oil Strainer, Filter or Magnetic Plugs)	6.4 6.5	F7-2	
<u>Voids (Bond Failures)</u>			
Main Rotor Blades	4.1	8-32	
Surface 1.0 Wide Typ			
0.50-3.0 Range			
Edge 0.06-20			

TABLE III. CH-47 AIDS REQUIREMENTS LISTING

Defect Type and Requirement	References	
	Checklist	-20TM
<u>Depth</u>		
1. Engine Drive Shaft	5.28 5.41	7-39
Maximum depth after burnishing: 0.009 inch		
Dents: Maximum Diameter 0.050 inch; Maximum depth 0.020 inch; minimum spacing 3.50 inch (magnifying glass, dye penetrant and dial indicator)		
2. Rotary-Wing Head	5.2 6.14	8-83
Damage to top and bottom surfaces: 0.005 inch maximum depth and 2.5 inch maximum length or 0.010 inch maximum depth and 1.0 inch maximum length. Side surface damage: 0.005 inch max- imum depth and 0.625 inch maximum length (Dial Indicator)		
3. Engine Variable Inlet Guide Vanes	3.17 4.19	5-121
Maximum depth 0.025 inch Maximum length 0.300 inch Maximum dent area 1/3 of vane area (one side) Maximum of 3 dents on vane leading edge (visual)		
4. Fan Assembly Drive Shaft	9.7	7-44
Maximum depth after burnishing: 0.012 inch Dents: maximum diameter 0.50 inch; Maximum depth 0.012 inch; minimum spacing 2.25 inch (magnifying glass dye penetrant, caliper)		
5. Rotary-Wing Blade	5.55 6.1	8-14
Nicks and scratches maximum 2 plies deep in the inboard fairing or more than one ply deep elsewhere. Dents: 0.030 to 0.062 inch deep, not to overlap (straight edge)		
6. External Cargo Hook Carriage Assembly	8.32	11-352
Maximum depth 0.040 inch		

Table III - Continued

Defect Type and Requirement	References	
	Checklist	-20TM
<u>Wear</u>		
1. Wheel Brake Disc and Linings	2.11	4.346
Disc thickness 0.170 inch minimum	2.23	
Width of key slots 0.781 inch maximum	7.12	
Lining thickness 1/32 inch minimum	7.25	
Distance between disc and housing (brakes applied) 3/16 inch maximum (ruler)		
2. Synchronizing Drive Shaft Bearing Housing Shock Mounts	6.8	7-24
Distance between the inside diameter of shock mount and outside diameter of spacer 0.007 inch maximum (Vernier Caliper)		
<u>Bearing Play/Looseness</u>		
1. Rotary-Wing Drive Shaft Thrust Bearing	5.20	-
Signs of overheating (visual)		
2. Swashplate Assembly	5.10	9-291
Any binding, looseness, noise or evidence of overheating indicative of bearing wear or damage (visual and by feel)	6.21	9-293
3. Connecting Link Assembly (Pitch Link)	5.6 6.18	9-274
Maximum radial play 0.006 inch (Dial Indicator)		
4. Flight Control Connecting Link	6.7 6.28	-
Maximum axial play 0.010 inch		
Maximum radial play 0.004 to 0.007 inch (Feeler Gage or Dial Indicator)		
5. Dual Actuator	5.12	9-220
Maximum axial play 0.010 inch		
Maximum radial play 0.005 inch (Feeler Gage)		

Table III - Continued

Defect Type and Requirement	References	
	Checklist	-20TM
6. Rotary-Wing Head Shock Absorber Maximum lost motion 0.008 inch (feel)	5.5 6.17	8-53
7. Aft Rotary-Wing Drive Shaft Bearing Evidence of overheating (visual)	5.20	
<u>Cracks</u>		
1. Landing Gear Support (visual)	2.10 2.24 7.13 7.24	
2. Landing Gear Support Structure (visual) Landing gear attach fittings (dye check)	2.13 2.27 7.15 7.27	
3. Upper and Lower Drive Arm and Collar (visual)	5.11	9-286
4. Main Rotor Pitch Varying Housing (visual)	5.3	8-83
5. Rotary Wing Head (visual)	-	8-83
6. Engine Mount (visual)	3.3 3.20 4.6 4.21	-
7. Engine Combustion Chamber	3.26	5-51 5-54
8. Engine Tail Pipe and Exhaust Diffuser Inner Cone Inside surface next to mounting ring flange (visual)	3.28 4.28	-
9. Engine Air Inlet Housing (visual with strong light beam)	3.17	5-118
10. Engine to Combining Gearbox Drive Shaft Adapter and Plate Assembly (dye penetrant)	5.28 5.41	7-39

Table III - Continued

Defect Type and Requirement	References	
	Checklist	-20TM
11. Aft Rotary-Wing Transmission Cracks in housing below the pressure port forward of the accessory gearbox mounting flange (visual)	9.20	
12. Combining Transmission Mount Structure Cracks in mount & adjacent structure (visual)	5.33	
13. Hydraulic Tank Cracks at bracket attachment (visual)	5.17 5.47	6-82
14. External Cargo Hook Carriage Assembly Cracks in side plates (visual)	8.32	11-352
<u>Leaks</u>		
Oil, Fuel, Hydraulic Lines and Hoses	3.6 3.19 4.17 (typ.)	
<u>Extension</u>		
Landing Gear Shock Strut Variable dimensions based on strut pressure (ruler and pressure gage)	2.9 2.22 7.11 7.23	1-93
<u>Metal Particles</u>		
1. Engine Oil Filter Foreign particle accumulation (visual)	3.9 4.7	5-659
2. Chip Detectors Any evidence of particles via continuity check or visual examination	3.8 3.21 4.4 4.8	5-640
3. Fuel Filter Foreign particle accumulation (visual)	3.11 3.12 3.13 (typ.)	5-805

Table III - Continued

Defect Type and Requirement	References	
	Checklist	-20TM
<u>Voids</u>		
Rotary-Wing Blade	5.55	8-14
Ply separations in fairing or bonded areas greater than 1 inch wide and 2 inches long extending to the skin edge.	6.1	
No bond voids in root box doublers.		
Nose cap finger edge voids: minimum 1 inch chordwise bond. Nose cap edge voids: over 1/4 total bonded area or within 3 inches of another void (visual and coin tap)		

TABLE IV. CH-54 AIDS REQUIREMENTS LISTING

Defect Type and Requirement	References	
	Checklist	-20TM -35TM
<u>Depth</u>		
1. First Stage Compressor Blades and Vanes	4.55 4.101	
No cracks or curling of blade tips acceptable (visual)		
2. Compressor Inlet Guide Vanes	4.54 4.100	
Surface defects (nicks, dents)		
3. Tail Rotor Drive Shaft Assy	4.137	7-24
Single scratch 0.015 inch maximum depth (visual)		
4. Engine Drive Shaft	4.28 4.29	
Surface defects (nicks, scratches)		
5. Engine Mount Deck Fittings	4.87 4.132	5-22
Surface defects (nicks, scratches, and dents)		
<u>Wear</u>		
1. Main Landing Gear Torque Arm Assembly Wear between arms and at attach points	2.7 2.22	4-147
Maximum lateral play 0.021 inch between torque arm and cylinder attach point		
Maximum lateral play 0.021 inch between torque arm and piston attach point		
Maximum lateral play 0.017 inch between torque arm (Dial Indicator)		
2. Nose Landing Gear Torque Arm Assembly	1.24	4-156
Wear between torque arms and attach points		

TABLE IV - Continued

Defect Type and Requirement	References	
	Checklist	-20TM -35TM
Maximum lateral play 0.024 inch between torque arm and cylinder attach point		
Maximum lateral play 0.024 inch between torque arm and piston attach point		
Maximum lateral play 0.019 inch between torque arms (Dial Indicator)		
3. Brake Linings	2.4 2.20	4-139
Maximum gap between brake housing face and lining 0.400 inch (Feeler Gage)		
4. Tail Rotor Control Cables	1.77	9-6
Wear of cable (visual)		
5. (N <sub>2</sub> ) Flexible Cable	4.70 4.114	5-131
Wear of shaft casing, core spirals and square drive. Maxi- mum allowable bend. 0.016 inch (steel rule)		
6. Thermocouple & Thermocouple Cable Assembly	4.145	
Wear and fraying of cable and terminals		
No rupture or fraying (visual)		
Minimum resistance 2500 ohms (ohmmeter)		
7. Main Landing Gear Brake Disc and Linings	2.4 2.20	4-139
Minimum disc thickness 0.110 inch		
Maximum key slot width 0.970 inch		
Maximum distance between piston cavity face and disc 0.400 inch (lining wear)		

TABLE IV - Continued

Defect Type and Requirement	References		
	Checklist	-20TM	-35TM
8. Rotor Brake Disc Minimum disc thickness 0.450 inch Maximum runout 0.015 inch TIR (dial indicator)	4.23	7-55	
9. Rotor Brake Wear of linings and disc Clearance between brake lining and disc 0.030-0.045 inch (feeler gage)	4.23	7-55	
10. Oil Cooler Pulley Belt Force required for 9/32 inch de- flection between the two pulleys should be 5-1/4 lb for new belts - 2-3/4 to 4 lb for old belts (spring scale)	4.26	7-40	
<u>Bearing Play/Looseness</u>			
1. Adjustable Control Rod (main rotor) Maximum end play 0.10 inch (feeler gage)	4.9		8-26
2. Tail Rotor Drive Shaft Support Bearings No bearing leaks (visual)	4.137	7-62 7-64	
3. Rod Assembly (Main Rotor) Maximum radial play 0.013 inch each bearing (upper and lower) Total allowable play both bear- ings 0.021 inch (dial indicator)	4.9	8-19	
4. Tail Rotor Pitch Change Link Maximum axial play 0.015 inch (dial indicator) Maximum drag torque 15 in.-lb (dial-type torque wrench)	5.18	8-42	

TABLE IV - Continued

Defect Type and Requirement	References		
	Checklist	-20TM	-35TM
5. Engine Mount Deck Fittings Maximum radial play 0.010 inch (dial indicator)	4.46A 4.92A	5-22	
6. Main Rotor Damper Outboard Bearing Maximum play 0.013 inch (dial indicator)	4.7A	8-13B	
7. Main Rotor Swashplate Maximum axial play of spherical bearing 0.050 inch (dial indicator)	4.13		8-30
8. Tail Rotor Sleeve & Spindle Bearing Roughness when blade is moved in circular direction			8-39B
<u>Cracks</u>			
1. Tail Skid Cracks in mounting lugs and brackets (visual)	5.25		
2. Main Landing Gear Wheel Cracks in wheel casting (visual)	1.24		
3. Thomas Coupling Cracks in coupling discs (visual)	4.28 4.30 4.137	7-61	
4. Tail Rotor Drive Shaft Assembly Cracks in shaft (visual)	4.137		7-24
5. Engine Drive Shaft Cracks in flange plates	4.29		
6. Cargo Fittings	3.6 3.30		

TABLE IV - Continued

Defect Type and Requirement	References		
	Checklist	-20TM	-35TM
7. Main Gearbox Mounting Frame	3.28		
8. Station 210 Splice Bracket	3.35		
9. Main Rotor Blade	4.5		18-65
Maximum length 2 inches spanwise, 1-3/8 inches chordwise. No crack within 2-1/2 inch of pocket leading edge or within 2 inches of another crack.			
10. Nose Gear Wheel and Axle	1.24		
11. Main Landing Gear Wheels	2.2 2.17		
12. Main Landing Gear to Support Structure Attach Fittings	2.14 2.28		
13. Main Landing Gear Support Installation Attach Fittings	2.15		
14. Tail Rotor Gearbox Mounting Lugs and Support Structure	5.22		
15. Free Turbine Case External Weldments and Bosses	4.66 4.111		5-44
<u>Torquing</u>			
1. Main Landing Gear-to-Support Attach Bolts	2.14	4-136A	
7400 inch-pounds (Torque Wrench)			
2. Main Landing Gear Support Installation Attach Bolts	2.15 2.32	4-86A	
3380 inch-pounds (Torque Wrench)			
3. Fuselage Splice Sta. 210 Bolts	1.82		
135-200 inch-pounds (Torque Wrench)			
4. Tail Rotor Gearbox Attach Bolts	5.21	7-81	
960 inch-pounds (Torque Wrench)			

TABLE IV - Continued

Defect Type and Requirement	References	
	Checklist	-20TM -35TM
5. Intermediate Gearbox Attach Bolts 405 inch-pounds (Torque Wrench)	5.24	7-76A
<u>Extension</u>		
1. Nose Landing Gear Shock Strut Dimension between centerlines of torque arm attachment: 3.50 to 14.30 inches based on shock strut gage pressure (900 to 155 psi)	1.19	4-150
2. Main Landing Gear Shock Strut Dimension between centerline of torque arm attachment: 3.50 to 14.30 inches based on shock strut gage pressure (635 to 105 psi)	2.8	4-136
3. Cargo Lashing Reel Tension of Cable Maximum preload 30 pounds reel- ing out Minimum preload 5 pounds reeling in.		15-38 15-46
<u>Metal Particles</u>		
1. Fuel Pressurizing and Dump Valve Foreign particle accumulation (visual)	4.79 4.123	
2. Main Coil Strainer Evidence of particles and foreign material (visual)	4.73 4.117	5-312
3. Chip Detector Oil Filter Metal particles (visual)	3.25	7-38
<u>Voids (Bond Failures)</u>		
Main Rotor Blade	4.5	18-64

- Bearing Play/Looseness
- Cracks
- Torque/Slippage
- Leaks
- Extension
- Alignment/Deflection
- Metal Particles
- Voids

### CONSOLIDATED MEASUREMENTS MATRIX

The inspection requirements data gathering effort was completed with the compilation of a Consolidated Inspection Requirements matrix shown in Table V. This matrix consolidates the measurement types and ranges from each of the aids requirements listings into one reference chart. The chart is organized into the same defect types as were used in the Aids Requirements Listings.

The consolidated inspection requirements were also translated into statements which gave direction to the search for inspection aids. These statements are presented by defect type below.

- Depth
  - Surface Defects: A noncontact device capable of measuring very narrow surface defects which are difficult or impossible to measure with mechanical indicators.
  - Corrosion: A device enabling high accuracy measurement of exposed surface corrosion and/or detection of hidden corrosion such as between aircraft skin and bulkheads.
- Wear
  - Rod End Bearings: An instrument which provides direct reading of axial and radial play for bearings located in limited access areas.
  - Shaft Bearings: Device(s) which provide direct reading of axial and radial play plus detection of bearing flaws such as cracked balls, Brinelled race, etc.

TABLE V. CONSOLIDATED INSPECTION REQUIREMENTS

Defect of Type Measurement	Summary Characteristics*	OH-6	OH-58	UH-1	A7-1	CH-47	CH-54
<u>Depth</u>							
Surface Defects	Range: .001-.250 Accuracy: + .0005	.001- .125	.002- .250	.002- .250	.002- .250	.025 .050	< .015
Corrosion	Range: .001-.020 Accuracy: + .005	.001 .125	-	.005- .010	.005 .010	.025 .020	< .015
<u>Wear</u>							
Rod End Bearings	Range: .001-.040 Accuracy: ± .001	.020- .040 (Radial)	.010	.005- .010 (Radial)	.020	< .010 < .007 (Radial)	< .015 < .013 (Radial)
Shaft Bearings	Range: .001-.040 Accuracy: ± .001	.040 (Axial) .015 (Radial)	.020 (Axial) .005 (Radial)	-	-	< .010 (Axial) < .005 (Radial)	< .024 (Radial)
Other (Direct Reading of Thickness)	Skid shoes/generator brushes/brake shoes	x/x/o	x/x/o	x/x/o	x/x/o	o/o/x	o/o/x
<u>Slippage</u>							
Fasteners	Range: 0-1800 in-lb or 0-150ft-lb Accuracy: ± 2%	25-325 in-lb	-	240- 950 in. lb	20-780 in. lb	-	-
<u>Alignment</u>							
Tail Rotor Shaft/Gearboxes	Range: N/A Accuracy: + .007 DIA X = Required	-	-	X	X	-	-
Landing Gear Alignment		-	X	X	X	-	-
<u>Flexing</u>							
Tail Rotor Drive Shaft	Characteristics Dependent Upon Measuring Device	X	X	X	X	-	-
<u>Metallic Element</u>	Particle Trapping and Accumulation	X	X	X	X	X	X

\*Dimensions are in inches unless otherwise indicated.

TABLE V - Continued

Defect of Type Measurement	Summary Characteristics*	OH-6	OH-58	UH-1	AH-1	GH-47	GH-54
<u>Cracks</u>							
Surface Cracks and Subsurface	Range: N/A						
Voids	Sensitivity: .03 in. <sup>2</sup>	NP**	NP	NP	NP	NP	NP
<u>Utilization Indicators</u>	Rotor Time Recorder/Shock/ Temperature/Leakage	X/X/0/X	X/X/X/X	X/X/X/X	X/X/X/X	X/X/X/X	X/X/X/X

\*Dimensions are in inches unless otherwise indicated  
 \*\*None permitted

- Thickness: A device which will provide a direct reading of material thickness by single side contact.
- Slippage
  - Fasteners: A legible, clearly visible indicator which would show if relative motion occurred between the fastener and its joint and/or directly determine bolt preload or torque without disturbing the fastener.
- Alignment
  - Tail Rotor Shaft/Gearboxes: Simple devices/methods allowing replacement of the numerous fixtures and adapters required to align 42° and 90° gearboxes on the UH-1 and AH-1 aircraft.
  - Landing Gear: A simplified measurement method that will reduce time and effort required for gear spread/alignment checks and improve accuracy.
- Flexing
  - Tail Rotor Drive Shaft: A device which can detect drive shaft flexing or whipping in fully assembled aircraft.
- Metallic Element
  - Gearbox /Engine: A plug device which will attract both magnetic and nonmagnetic particles and give visual evidence of particle collection without removal from aircraft.
- Cracks
  - Surface Cracks/Subsurface Voids: A device capable of detecting surface fractures in ferrous and non-ferrous metal parts and detecting bond failures, voids, and delamination in metal and nonmetal structures.
- Utilization Indicators
  - Shock: A latching accelerometer which indicates when safe "G" levels have been exceeded such as on hard landings.

- Temperature: An indicator paint, plastic or tape which gives a visual indication when safe operating temperatures have been exceeded on bearings, etc.
- Leakage: A leak detector which can be cheaply applied to fittings and supply lines in the hydraulic and fuel systems to continuously monitor them for leaks.

## INSPECTION AID EVALUATIONS

### FEASIBILITY EVALUATION

A feasibility evaluation was conducted to define and list available aids considered feasible in keeping with the program objectives. Those types of candidate off-the-shelf and conceptual aids recommended for further evaluation as the result of initial analyses along with other aids derived from the outputs of the WESRAC computer search, were first defined to greater depth. Further vendor contact was then made to obtain sufficient definition of off-the-shelf candidate devices. Where possible, vendor hardware was demonstrated and tested for suitability by performing simulated or actual inspections. This section discusses the results of the computer search and vendor hardware demonstrations.

### WESRAC Computer Search

In order to perform a thorough inspection aid candidate search, the Western Research Application Center (WESRAC) was contracted to conduct a computer search for potential helicopter inspection aids and techniques.

The computer search used a number of available commercial and scientific data banks in the process of seeking small, low-cost inspection devices. Several key words were tied to the data bank in each case to extract the information desired. These words were:

Vibration Frequency	Fracture
Vibration Amplitude	Shock
Bolt Tension	Bearing Wear
Skid Shoe Wear	Indicator
Bonding Void	Detector
Delamination	Fluid Level
Crack	Reed Tachometer
Hydraulic Leak	Balancing
Metallic Element	Torque Stripe
Slippage	Reed Vibration Sensor
Ultrasonic	Temperature Sensitive Paint
Eddy Current	

The resultant information included:

1. NASA Data Bank Abstracts
2. Engineering Index Abstracts
3. Torque-Tension Testing Material
4. NASA Tech Briefs
5. Fluid Sight Indicators and Fluid Indicators
6. Wear Measurement Information
7. Indicating Micrometers and Dial Indicators
8. Metal Detector Shock and Vibration Measurements.

Those devices and instruments which were judged to be suitable to the objectives of this program are described in this report. An example of the information furnished in the NASA Tech Brief is shown in Figure 3. This brief discusses an ultrasonic wrench which is under development by Marshall Space Flight Center.

### Vendor Demonstrations

Several vendors were contacted and asked to loan their instruments for evaluation. Unfortunately, program constraints did not permit a thorough demonstration of trial of all the instruments/devices presented in this report. Many instrument manufacturers were enthusiastic about their own products and personally demonstrated them. The following are brief notes on the product demonstrations conducted.

Automation Industries - Automation demonstrated a large variety of portable ultrasonic, x-ray, eddy current and gamma radiography equipment.

Arizona Gear and Manufacturing Company - Shockmaster "G" level indicators were demonstrated. They are a low-cost, compact, mechanical device that may be used over and over again to monitor excessive shock and vibration. Applications within this program include their use as hard landing indicators.

Bausch and Lomb - A scratch depth gage on loan from their Microline Division was shown. This is a small, hand-held, battery-operated, direct reading, optical instrument. It provides an accurate, rapid and inexpensive means for determining whether the depth and width of surface scratches or indentations exceed prescribed limits.

# NASA TECH BRIEF



NASA Tech Briefs are issued to summarize specific innovations derived from the U.S. space program, to encourage their commercial application. Copies are available to the public at 15 cents each from the Clearinghouse for Federal Scientific and Technical Information, Springfield, Virginia 22151.

## Ultrasonic Wrench Produces Leaktight Connections

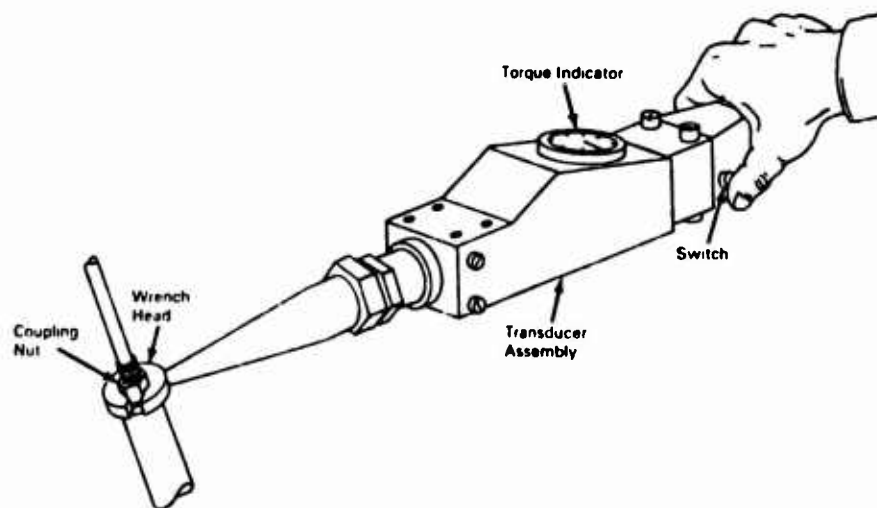

### The problem:

To design a tool that will ensure a greater reliability of obtaining leaktight seals in flared tubing connections. In this type of connection, a seal is obtained by rotating a coupling nut to compress the tubing flare against the union bevel. A major portion of the torque applied by a wrench overcomes friction in the threads between the back shoulder of the nut and the face of the compression sleeve and between the sleeve and the tubing flare. These frictional forces vary from assembly to assembly and result in uncontrollable compression in the seal area when the connections are tightened to a specified torque with conventional wrenches.

### The solution:

An ultrasonic wrench system which induces a flexural vibration mode in the nut. The system consists of a frequency converter, a junction box and wrench assembly.

### How it's done:

The frequency converter (a solid state circuit in a standard switch box) converts line power to 28 kHz, timed to provide 3-second output pulses. The junction box contains an impedance matching network, a transformer, an inductance coil, an overvoltage spark gap, a cooling-air regulator, and an air pressure gage. The wrench assembly incorporates a lead zirconate titanate transducer, which delivers from 70 to 85 percent of

(continued on page 2)

This document was prepared under the sponsorship of the National Aeronautics and Space Administration. Neither the United States Government nor any person acting on behalf of the United States

Government assumes any liability resulting from the use of the information contained in this document, or warrants that such use will be free from privately owned rights.

Figure 3. NASA Tech Brief 67-10353, Sheet 1 of 2.

the high frequency electrical power into an acoustic load, and is provided with a standard dial indicator, calibrated in inch-pounds of torque. Acoustically designed 12-point, open-end wrench heads for each size fitting are mechanically interchangeable by means of a precision acoustical junction. The complete wrench assembly with a wrench head in place weighs approximately 11 pounds.

Use of the wrench assembly to tighten a flared tubing connection is shown in the illustration. The operator first tightens the coupling nut to the specified torque as observed on the dial indicator; he then depresses the thumb switch, exciting the transducer to the preset power level. During the fixed 3-second pulse application, the operator maintains the desired torque as the ultrasonic energy reduces friction and permits additional tightening of the nut to occur.

**Notes:**

1. This type of wrench should be useful in various operations requiring a reliable torquing tool.
2. Inquiries concerning this development may be directed to:

Technology Utilization Officer  
Marshall Space Flight Center  
Huntsville, Alabama 35812  
Reference: B67-10353

**Patent status:**

Inquiries about obtaining rights for the commercial use of this invention may be made to NASA, Code GP, Washington, D.C. 20546.

Source: H. T. Blaise  
of Marshall Space Flight Center  
and N. Maropis  
of Technidyne Incorporated  
under contract to  
Marshall Space Flight Center  
(MSF-12561)

Brief 67-10353

Category 05

**Figure 3. NASA Tech Brief 67-10353, Sheet 2 of 2.**

IRD Mechanalysis, Incorporated - IRD demonstrated two units which can be used with or without an X-Y plotter. These units can detect sonic and high frequency vibrations associated with excessive bearing wear and imminent failure. IRD's equipment obviously can perform the analysis, but its application must be evaluated on the basis of its obvious sophistication (although a training program for operating personnel, ususally two days, is included as a part of procurement) and high initial cost.

Modulus Corporation - The "Tell-Torq" bolt is a fastener with an optical indicating system that is secured within the head to give an instant indication of the load being applied to the bolt. When a "Tell-Torq" equipped fastener is tightened to a prescribed stress load, the optical indicator visible in the head will register immediately when the desired stress is achieved, simply by changing color from a bright red to dark blue or blue black. Should the fastener become loose, the color would automatically change back to the red color, indicating a loss of tension. The operation is repeatable an infinite number of times and will remain reliable virtually for the life of the fastener. This product has been successfully tested under all kinds of operating conditions and is unaffected by a temperature range of -60°F to 400°F, pressure, vibration, scale, dirt, dust or lubrication. Also available is a modification that will indicate when the yield stress of the fastener has been exceeded.

Parker Research - Parker demonstrated a hand-held battery-operated audio probe. The probe is an electronic, solid-state, eddy current instrument that provides a positive and reliable go/no-go audio tone earphone readout. The instrument will detect cracks in ferrous and nonferrous materials and by the comparative method identify heat damaged metal, sort for alloy or heat treat variation, measure nonconductive coating thicknesses on metal surfaces, and separate aluminum foils in 0.001 increments.

### Plastic Impression Tests

The use of a "plastic glue" is a simple depth measurement technique which warranted a laboratory test to determine how good it was. The technique heats a cylinder of polyethylene adhesive to a plastic condition in an electric pistol

grip gun. The plastic is then injected onto the area under examination. A hard object such as a block of metal is then pressed against the cooling plastic. The plastic fills the indentation and cools or solidifies in about 15 seconds. Upon removal from the indentation, this impression is then measured using a dial caliper or dial indicator. The measured results will give the width and depth of the indentation.

Tests were conducted using aluminum scrap flat material with scratch or dent damage. Table VI presents the results.

TABLE VI. PLASTIC IMPRESSION TESTS			
Surface Blemish Measured*	Blemish Number	Actual Blemish Depth Measurement (in.)	Plastic Impression Height Measurement (in.)
Indentation Caused by Heavy Center Punch	1	0.048	0.044
	2	0.028	0.026
File Scratch	1	0.0015	0.002
	2	0.001	0.001
*All dimensions checked with calibrated dial indicator using different contact points.			

#### CANDIDATE FEASIBILITY EVALUATION

A candidate feasibility evaluation was performed to determine those inspection aids which were of superior effectiveness in use, cost, maintenance and application. The evaluation was divided into 17 smaller analyses based on the specific problems determined during the requirements analysis. Each evaluation utilized a weighted multiplier scoring form for each device type judged to meet the specific problem application. The results of these evaluations are presented below.

#### Evaluation Score Sheet

The score sheet utilized is presented in Figure 4. Five basic evaluation areas are included on the score sheet:

DEVICE:	APPLICATIONS:
---------	---------------

<p><u>1. EFFECTIVENESS</u></p> <p>15 <input type="checkbox"/> FAULT DETECTION CAPABILITY  <input type="checkbox"/> VERY HIGH  <input type="checkbox"/> HIGH  <input type="checkbox"/> MODERATE</p> <p>10 <input type="checkbox"/> ERROR POTENTIAL  <input type="checkbox"/> LOW  <input type="checkbox"/> MODERATE  <input type="checkbox"/> HIGH</p> <p>10 <input type="checkbox"/> INSPECTION SUBJECTIVITY  <input type="checkbox"/> NONE  <input type="checkbox"/> MODERATE  <input type="checkbox"/> CONSIDERABLE</p> <p><u>2. USE FACTORS</u></p> <p>8 <input type="checkbox"/> SKILL REQUIRED  <input type="checkbox"/> SOME  <input type="checkbox"/> MODERATE  <input type="checkbox"/> CONSIDERABLE</p> <p>7 <input type="checkbox"/> TRAINING REQUIRED  <input type="checkbox"/> NONE  <input type="checkbox"/> O.J.T.  <input type="checkbox"/> FORMAL</p> <p>2 <input type="checkbox"/> SAFETY PRECAUTIONS  <input type="checkbox"/> NORMAL  <input type="checkbox"/> ABOVE NORMAL  <input type="checkbox"/> CONSIDERABLE</p> <p>3 <input type="checkbox"/> POWER REQUIREMENTS  <input type="checkbox"/> NONE  <input type="checkbox"/> SELF CONTAINED  <input type="checkbox"/> EXTERNAL SOURCE</p>	<p><u>2. USE FACTORS (CONT.)</u></p> <p>6 <input type="checkbox"/> PORTABILITY  <input type="checkbox"/> HAND HELD  <input type="checkbox"/> PORTABLE  <input type="checkbox"/> NON-PORTABLE</p> <p>4 <input type="checkbox"/> INSPECTION TIME  <input type="checkbox"/> LOW  <input type="checkbox"/> MODERATE  <input type="checkbox"/> HIGH</p> <p><u>3. COST FACTORS</u></p> <p>10 <input type="checkbox"/> COST PER UNIT  <input type="checkbox"/> UNDER \$200  <input type="checkbox"/> \$200-\$1,000  <input type="checkbox"/> OVER \$1,000</p> <p>10 <input type="checkbox"/> NO. OF UNITS PER COMPANY  <input type="checkbox"/> ONE  <input type="checkbox"/> TWO-THREE  <input type="checkbox"/> OVER THREE</p> <p><u>4. DEVICE MAINTENANCE</u></p> <p>4 <input type="checkbox"/> CALIBRATION REQUIRED  <input type="checkbox"/> NONE  <input type="checkbox"/> OCCASIONAL  <input type="checkbox"/> FREQUENT</p> <p>4 <input type="checkbox"/> DEVICE RELIABILITY  <input type="checkbox"/> HIGH  <input type="checkbox"/> MODERATE  <input type="checkbox"/> LOW</p> <p>2 <input type="checkbox"/> DEVICE COMPLEXITY  <input type="checkbox"/> SIMPLE  <input type="checkbox"/> MODERATE  <input type="checkbox"/> COMPLEX</p>	<p><u>5. APPLICATION FACTORS</u></p> <p>2 <input type="checkbox"/> PRESENT USERS  <input type="checkbox"/> D.D AND COMMERCIAL  <input type="checkbox"/> COMMERCIAL ONLY  <input type="checkbox"/> NONE</p> <p>1 <input type="checkbox"/> PROBLEM APPLICATIONS  <input type="checkbox"/> MANY  <input type="checkbox"/> SEVERAL  <input type="checkbox"/> ONE</p> <p>1 <input type="checkbox"/> AIRCRAFT APPLICATIONS  <input type="checkbox"/> ALL  <input type="checkbox"/> SEVERAL  <input type="checkbox"/> ONE</p> <p>1 <input type="checkbox"/> MAINTENANCE LEVELS  <input type="checkbox"/> ORG. AND HIGHER  <input type="checkbox"/> D.S. AND HIGHER  <input type="checkbox"/> G.S. AND DEPOT</p> <p><u>SCORES</u></p> <p>EFFECTIVENESS.....</p> <p>USE FACTORS.....</p> <p>COST FACTORS.....</p> <p>MAINTENANCE.....</p> <p>APPLICATIONS.....</p> <p>TOTAL <input style="width: 50px;" type="text"/></p>
--	--	--

Figure 4. Feasibility Evaluation Score Sheet.

- Effectiveness
- Use Factors
- Cost Factors
- Device Maintenance
- Application Factors

The number written to the left of the item score box is the weighted multiplier. The numbers used as weighted multipliers were selected based on each item's applicability to contractual objectives. Thus, cost and effectiveness items received the highest weights followed by use factors, device maintenance and application factors.

All subitems have a score value of 3, 2 and 1 descending in that sequence order. Thus, for a given item (for example, Fault Detection Capability), the maximum score is 3 times the weighted multiplier (in this case  $3 \times 15 = 45$ ). The sum of the evaluation item scores for an area is presented in the lower right corner of the form. Scoring in this manner provides a range of scores each device type can have for a given application. This range is:

<u>Factor</u>	<u>Minimum</u>	<u>Maximum</u>
Effectiveness	35	105
Use	30	90
Cost	20	60
Device Maintenance	10	30
Application	<u>5</u>	<u>15</u>
	100	300

Engineering judgment was used to assign the weights indicated. The total score is computed by summing all the area scores and dividing by three to "normalize" to a base of 100.

#### Feasibility Evaluation Scoring Results

The total scores of each specific problem application follow along with a brief comment on each.

### Surface Defects (Nicks, Scratches, Gouges)

<u>Evaluated Items</u>	<u>Score</u>
Optical Comparitor	93
Plastic Impression	90
Electronic Gage	83

The optical comparitor, a relatively small hand-held instrument, is preferable to the hot melt gun and time delay of the plastic impression technique.

### Surface Cracks (Nonmetallic material)

<u>Evaluated Items</u>	<u>Score</u>
Fluorescent Penetrant	81*
Peeperscopes (Remote Areas)	81

Although the scores are tied, the fluorescent penetrant technique is much more effective (indicated by \*). Peeperscopes are useful when inspecting for surface cracks in remote areas. In many cases disassembly will be unnecessary.

### Surface Cracks (Aluminum or Magnesium Sheet Metal)

<u>Evaluated Items</u>	<u>Score</u>
Fluorescent Penetrant	81*
Peeperscopes (Remote Areas)	81
Eddy Current Testers	69
Ultrasonic Testers	66

Fluorescent penetrant inspection is also more effective to detect surface cracks in aluminum or magnesium sheet metal.

### Surface/Subsurface Cracks (Forgings, Extrusions, Castings)

<u>Evaluated Items</u>	<u>Score</u>
Fluorescent Penetrant (Surface cracks only)	81
Eddy Current Testers	69
Ultrasonic Testers	66
X-Ray	61

Fluorescent penetrant again scores highly particularly in the detection of surface cracks in forgings, extrusions and castings.

#### Rod End Bearing Wear

<u>Evaluated Items</u>	<u>Score</u>
Bearing Wear Pin	98
Linear Displacement Sensor	86
Fotonic Sensor	83

All three items are developmental in nature. The bearing wear pin is simple and does not require the placement of sensor holding clamps.

#### Degradation of Ball or Roller Bearings

<u>Evaluated Items</u>	<u>Score</u>
Temperature Indicating Tabs	87
Temperature Indicating Crayons	85
Temperature Indicating Lacquer	84
Reed Vibration Monitors	65
Ultrasonic Translators	52

Degradation of ball or roller bearings is almost always accompanied by an overtemperature condition. Because of their simplicity, the three temperature items rank highly.

#### Slippage Measurement-Torquing

<u>Evaluated Items</u>	<u>Score</u>
Optical Indicating System	99
Visual Preload Indicator	86

The optical indicating system is easy to read, is built in, is of low cost, and requires no additional installation work than what is presently performed.

### Slippage and Overtemperature

<u>Evaluated Items</u>	<u>Score</u>
Indicator Label	94
Temperature Indicating Label	90

The indicator label, although a developmental item, rates higher because it is a combined slippage and temperature indicating system.

### Difficult Access Visual Inspection

<u>Evaluated Item</u>	<u>Score</u>
Flexible Fiber Optic Scope	94

Flexible fiber optic scopes are ideally suited to visual inspection in difficult access areas. They are also applicable to surface crack inspections.

### Landing Gear Alignment

<u>Evaluated Item</u>	<u>Score</u>
Shock Indicators	92

A new method for checking landing gear spread and alignment is discussed on page 148. Shock indicators are useful to indicate when to inspect.

### Vibrations (Excessive Flexing/Whipping)

<u>Evaluated Items</u>	<u>Score</u>
Diagnostic Reed Vibration Instrument	81
Vibration Analyzer Dynamic Balancer	73
Reed Vibrometer	72

The diagnostic reed vibration instrument (a developmental item) is highly rated because it is easy to use and provides direct diagnostic information.

### Delaminated/Debonded Structures

<u>Evaluated Items</u>	<u>Score</u>
Eddy-Sonic Tester	64
Low Frequency Ultrasonic Tester	63

### External Leakage

<u>Evaluated Items</u>	<u>Score</u>
Leak Indicating Tape	99
Leak Indicating Powder	94
Leak Indicating Paint	94
Leak Indicating Pads	90
Fluorescent Tracer Additive	88
Ultrasonic Translators	62

### Internal Leakage

<u>Evaluated Item</u>	<u>Score</u>
Ultrasonic Translators	62

### Pitting or Surface Corrosion

<u>Evaluated Items</u>	<u>Score</u>
Fiber Optic Scopes (Remote Areas)	81
Fluorescent Oil	73

Pitting or surface corrosion can be found in difficult access areas with fiber optic scopes.

### Galvanic Corrosion

<u>Evaluated Items</u>	<u>Score</u>
X-Ray	70
Ultrasonic Testers	56

The X-Ray inspection method is superior to ultrasonic test equipment in the detection and assessment of galvanic corrosion.

## Exfoliation Corrosion

<u>Evaluated Items</u>	<u>Score</u>
X-Ray	70
Eddy Current Testers	59
Ultrasonic Testers	56

X-Ray methods are also more effective in the evaluation of exfoliation corrosion than eddy current or ultrasonic test techniques.

## INSPECTION PROBLEM EVALUATION

An evaluation was performed to determine those inspection problems which pose the greatest difficulty for technical inspectors and mechanics. The same 17 application problems used in the candidate feasibility evaluation were evaluated. These problems also stemmed from the requirements analysis work performed earlier. Each problem was simply evaluated utilizing a weighted multiplier scoring form.

### Inspection Problem Evaluation Score Form

The scoring form used is presented in Figure 5. Six multiple-choice evaluation factors were utilized including inspection frequency, inspection time, inspection skill, subjectivity, error rate and resource costs. These topics were selected because they directly relate to the programs objectives and to cost effectiveness considerations. Inspection problems are important from a cost standpoint because their effect is felt continually over the life of the aircraft. Inspection problems can be reduced through the use of inspection aids which result in:

- Reduction of Inspection Time
- Increase in Inspection Subjectivity
- Reduction in False Diagnoses (resultant savings in repair time and spares costs)

INSPECTION PROBLEM:	
40	<input type="checkbox"/> INSPECTION FREQUENCY
	<input type="checkbox"/> HIGH
	<input type="checkbox"/> MODERATE
	<input type="checkbox"/> LOW
20	<input type="checkbox"/> INSPECTION TIME
	<input type="checkbox"/> HIGH
	<input type="checkbox"/> MODERATE
	<input type="checkbox"/> LOW
8	<input type="checkbox"/> INSPECTION SKILL
	<input type="checkbox"/> HIGH
	<input type="checkbox"/> MODERATE
	<input type="checkbox"/> LOW
13	<input type="checkbox"/> SUBJECTIVITY
	<input type="checkbox"/> HIGH
	<input type="checkbox"/> MODERATE
	<input type="checkbox"/> LOW
12	<input type="checkbox"/> ERROR RATE
	<input type="checkbox"/> HIGH
	<input type="checkbox"/> MODERATE
	<input type="checkbox"/> LOW
7	<input type="checkbox"/> RESOURCE COST
	<input type="checkbox"/> HIGH
	<input type="checkbox"/> MODERATE
	<input type="checkbox"/> LOW
<input type="checkbox"/> TOTAL SCORE	
<input type="checkbox"/> ADJUSTED SCORE	

Figure 5. Inspection Problem Evaluation Score Sheet.

- Increase in Fault Detection Capability (reduction in maintenance induced failures)

The scoring form has been designed to assess the severity of the inspection problem as it exists today, with today's inspection methods. The number to the left of the item score box is the weighted multiplier. Numbers used are highest for those items which have the greatest impact on inspection life-cycle costs. Thus, inspection frequency and inspection time have the highest multipliers. Subjectivity and error rate have been given the next highest weights because they rate the problem from the effectiveness of today's inspection methods to finding the problem. Resource cost and inspection skill have been given the lowest weights because they have the least effect on the problem severity evaluation. The three subitems (high, moderate, low) have a score value of 3, 2 and 1 descending in that sequence order. To obtain the score for a given item the subitem number checked (3, 2 or 1) is multiplied by the weighted multiplier. The sum of the evaluation item scores is presented at the bottom of the form in the box identified "Total Score". This number is also "adjusted" to a base of 100 by dividing by 3. Scoring in this manner gives a range of scores for each item as follows:

<u>Item</u>	<u>Minimum</u>	<u>Maximum</u>
Inspection Frequency	40	120
Inspection Time	20	60
Inspection Skill	8	24
Subjectivity	13	39
Error Rate	12	36
Resource Cost	7	21
	<u>100</u>	<u>300</u>

### Inspection Problem Scoring Results

The adjusted scores are given on the next page for each specific problem evaluated. Again, the higher the score, the greater the problem severity.

<u>Inspection Problem</u>	<u>Score</u>
1. Wear in rod end bearings	91
2. Depth measurement of surface defects such as nicks and scratches	80
3. External leakage	74
4. Delaminated/debonded	71
5. Internal degradation of ball and roller bearings	71
6. Internal leakage	71
7. Galvanic corrosion	65
8. Surface cracks in major structural forgings, extrusions, or castings	65
9. Loss of torque on bolts	62
10. Landing gear spread measurement	60
11. Flexing or whipping of drive shafts	53
12. Spinning of bearing races	48
13. Pitting or surface corrosion	47
14. Surface cracks in aluminum or magnesium sheet metal	47
15. Surface cracks in nonmetallic material	47
16. Exfoliation corrosion	46
17. Subsurface cracks in major structural forgings, extrusions or castings	45

#### INSPECTION AID EFFECTIVENESS RANKING

The final evaluation performed was an effectiveness ranking of recommended inspection aids. The prime factors used (high

weighted items) were cost effectiveness and inspection system effectiveness. The purpose of this evaluation was to determine those inspection aids which the U.S. Army has the greatest need for.

### Inspection Aid Ranking Results

The inspection aid effectiveness ranking combined the results of the two previous analyses to determine the effectiveness of using the recommended inspection aids (developmental or off-the-shelf) in solving today's inspection problems. This was accomplished by multiplying together the resultant scores of the two previous evaluations on an application or inspection problem basis. This resulted in a ranking of inspection aids based on problem severity. The multiplication result was divided by 100 to again adjust the score to a numerical value lying between 0 and 100. The results follow:

<u>Inspection Aid</u>	<u>Inspection Problem</u>	<u>De-vice Score</u>	<u>Prob-lem Score</u>	<u>Effec-tive-ness Score</u>
1. Bearing Wear Pin	Wear in rod end bearings	98	91	89.2
2. Optical Comparitor	Depth measurement of surface defects such as nicks and scratches	93	80	74.4
3. Leak Indicating Tape	External leakage	99	74	73.3
4. Temperature Indicating Tabs	Internal degradation of ball or roller bearings	87	71	61.8
5. Optical Indicating System	Loss of torque on bolts	99	62	61.4

	<u>Inspection Aid</u>	<u>Inspection Problem</u>	<u>De-vice Score</u>	<u>Prob-lem Score</u>	<u>Effec-tive-ness Score</u>
6.	Fluorescent Penetrant	Surface cracks in major structural forgings, extrusions, or castings	81	65	52.7
7.	Shock Indicator	Landing gear spread measurement	92	60	55.2
8.	X-Ray	Galvanic corrosion	70	65	45.5
9.	Eddy-Sonic Tester	Delaminated/debonded honeycomb structures	64	71	45.4
10.	Indicator Label	Spinning of bearing races	94	48	45.1
11.	Ultrasonic Translator	Internal leakage	62	71	44.0
12.	Diagnostic Reed Vibration Instrument	Flexing or whipping of drive shafts	81	53	42.9
13.	Fluorescent Penetrant	Surface cracks in aluminum or magnesium sheet metal	81	47	38.1
14.	Fiber Optic Scopes (Remote Areas)	Pitting or surface corrosion	81	47	38.1
15.	Fluorescent Penetrant	Surface cracks in nonmetallic material	81	47	38.1
16.	X-Ray	Exfoliation corrosion	70	46	32.2
17.	Eddy Current Testers	Subsurface cracks in major structural forgings, extrusions, or castings	69	45	31.1

The above listing contains three items which supplement current inspection aids and methods (numbers 7, 13 and 15). Two of these do not employ the inspection method judged to be best or most useful today or in the future. As noted previously, shock indicators are useful to indicate when to inspect and as such are an indicator of when to employ a new landing gear spread measurement technique. (See page 149.) Items 13 and 15 list fluorescent penetrant as the inspection aid to solve the problems of surface cracks in aluminum or magnesium sheet metal and nonmetallic material. For these applications, the current inspection methods are judged to be of greater utility and will undoubtedly be used for some time to come. The current methods are static visual checks with the unaided eye sometimes complemented with optical magnification checks.

## INSPECTION PROBLEMS AND APPLICABLE EQUIPMENT

### PROBLEM DESCRIPTIONS, SOLUTIONS AND INSPECTION AIDS

This section provides the detailed data for the investigation of inspection aids. It contains general and specific problem discussions, generic inspection method discussions, and descriptions of the evaluated specific equipment (devices, instruments, and conceptual designs). The organization is centered around the several general problem areas mentioned previously in the aids requirements listing discussion:

- Depth Measurement
- Cracks
- Rod End Bearing Wear
- Bearing Wear
- Slippage Measurement - Torquing
- Slippage - Positional Measurement
- Alignment
- Flexing
- Delaminations/Debonds
- Leakage
- Corrosion

The organization of this section is illustrated in Table VII which is also a page reference chart for the specific inspection aids evaluated. Table VII illustrates the "tree" organization utilized where the general problem areas lead to specific problems; in turn the specific problems are solvable by generic inspection methods utilizing the referenced instruments and devices.

### DEPTH MEASUREMENT - SURFACE DEFECTS

Minute surface defects such as nicks, scratches, or Brinell marks in shafts or wear surfaces are often cause for replacement of a part. In most cases, these defects are impossible to measure with a mechanical depth gage or dial indicator; as a result, the normal technique appears to be repair first and then determine if the repair depth is excessive. Typical applications where depth measurement is required for nicks, gouges and scratches are skid tubes, main rotor blades, main rotor hub assembly, stabilizer bar, engine mount rods/braces,

TABLE VII. PROBLEMS VERSUS INSPECTION AIDS PAGE REFERENCE CHART

General Problems	Specific Problems	General Inspection Method	Specific Equipment	Page
Depth Measurement Pg 54	Surface defects including nicks, scratches and gouges Pg 54	Optical Comparators, Electronic Gages and Plastic Impression P., 59	Bausch and Lomb Scratch Depth Gage	60
Cracks Pg 63	Surface cracks in non-metallic material Pg 65	Flexible Fiberscopes Pg 66	Plastic Impression American Optical #FS 100 American Optical #PS3-18	62 68 69
		Fluorescent Penetrant Inspection Pg 71	MIL-I-25135C Groups IV, V, VI and VII Ultra-Violet Products, Inc., N-16 Blak-Ray	72 75
		Flexible Fiberscopes Pg 66	Ultra-Violet Products, Inc., ML-49 Blak-Ray	77
	Surface cracks in aluminum or magnesium sheet metal Pg 65	Fluorescent Penetrant Inspection Pg 71	American Optical #FS 100 American Optical #PS3-18	68 69
		Eddy Current Testing Pg 79	MIL-I-25135C Groups IV, V, VI and VII Ultra-Violet Products, Inc., N-16 Blak-Ray Ultra-Violet Products, Inc., ML-49 Blak-Ray	72 70 77
			Nortec #NDT-2 Magnaflux #ED-520 Sperry #EM-1500 Sperry #EM-3100 Forster Defectometer #2.164	81 83 85 86 88
		Ultrasonic Test Equipment Pg 93	Parker Research #EC-550 Branson #303 Krautkramer #USM2 Sperry #UVP Sperry #UJ	90 95 97 99 101

TABLE VII - Continued

General Problems Cracks (Cont.) Pg 63	Specific Problems Surface and subsurface cracks in major struc- tural forgings, ex- trusions, or castings Pg 66	General Inspection Method Fluorescent Penetrant Inspection Pg 71	Specific Equipment Device	Page
		Eddy Current Testing Pg 79	MI-1-25135C Groups IV, V, VI, and VII Ultra-Violet Products, Inc., M-16 Blak-Ray Ultra-Violet Products, Inc., ML-49 Blak-Ray Nortec #NDT-2 Magnaflux #ED-520 Sperry #EM-1500 Sperry #EM-3100 Forster Defectometer #2,164 Parker Research #EC-550 Branson #303 Krautkramer #USM2 Sperry #IVP Sperry #IJ Fexitron #846 Sperry #SPX 120KV Sperry #160EA-8 Balteau #140B	72 75 77 81 83 85 86 88 90 95 97 99 101 105 107 109 111
Wear Pg 113	Rod End Bearings Pg 113	Built-in Pins, Linear Transducer, and Fiber Optic Probe Pg 113	Bearing Wear Pin (To be developed) Linear Displacement Sensor (To be developed) Fotonic Sensor (To be modified) Hewlett-Packard #4918A	114 118 121 125
	Ball and collar bear- ing internal degrada- tion Pg 123	Temperature Indicating Labels Pg 128 Temperature Indicating Paint Pg 131 Temperature Indicating Crayon Pg 133	Omega Temp Tabs Series AA, 4A, B, C, and S Omega Temp Sensitive Paint Crayon	129 131 133
	Reed Vibration Monitors Pg 134		Korfund 120-15,000 CPM Vibroscope Co. #NR	135 137

TABLE VII - Continued

General Problems		Specific Problems	General Inspection Method	Specific Equipment	Page
Slippage Measurement Pg 139		Torquing Pg 139	Built-in Bolt Preload Indicators Pg 139	Modulus Corporation	140
				III Research Institute	143
Alignment Pg 148		Positional Measurement (Temperature related) Pg 145	Temperature Indicating Labels, Slippage Labels Pg 128	Visual Preload Indicator	129
				Omega Temp Tabs Temperature Label	146
Flexing Pg 156	Flexing Fault Determination Pg 156	Alignment Measurement Pg 148	Landing Gear Spread Alignment Check Pg 149	Indicator Label (To be developed)	149
				Shock Indicators (when to inspect) Pg 150	149
Delamination/Debonding/Leakage Pg 171	Delaminated/Debonded Honeycomb Structures External Leakage Pg 172		Dynamic and Reed Vibration Monitors Pg 134	New Landing gear check method	152
				Shock Indicator	153
Delamination/Debonding/Leakage Pg 171				Humphrey Inc. Planar Accelerometer	152
				Ariz. G&M Co. Shock Overload Indicator	154
Delamination/Debonding/Leakage Pg 171				IRD Mechanalysis, Inc. Vibration Analyzer	157
				Vibroscope Company, Inc., Davey Vibrometer	137
Delamination/Debonding/Leakage Pg 171				Korfund Dynamics Corp. Reed Vibrometer	135
				Diagnostic Reed Vibration Instrument (To be developed)	159
Delamination/Debonding/Leakage Pg 171				Sperly Sondicator S-2B	166
				Shurtronics Mark II	169
Delamination/Debonding/Leakage Pg 171				American Gas & Chem Jet Tec A and B	173
				American Gas & Chem ODP-110	175
Delamination/Debonding/Leakage Pg 171				American Gas & Chem Bug-It ODP	176
				American Gas & Chem ODP-110 Pads	178
Delamination/Debonding/Leakage Pg 171				Shannon Luminous T-100 Series	181
				Hewlett-Packard #4918A	125
Delamination/Debonding/Leakage Pg 171				Hewlett-Packard #4918A	125
				Internal Leakage Pg 176	125

TABLE VII - Continued

General Problems	Specific Problems	General Inspection Method	Specific Equipment	Page	
Corrosion Pg 182	Pitting or surface corrosion Pg 182	Flexible Fiberscopes Pg 66	American Optical #FS 100	66	
			American Optical #PS3-18	69	
			Sherwin Inc #HM400-Plus	184	
	Galvanic corrosion Pg 182	X-Ray Pg 103	Fexitron #846	105	
			Sperry #SPX 120 KV	107	
			Sperry #160EA-8	109	
	Exfoliation corrosion Pg 183	X-Ray Pg 103	Balteau #140B	111	
			Branson #303	95	
			Krautkramer #USM2	97	
	Corrosion Pg 182	Eddy Current Testing Pg 79	Ultrasonic Test Equipment Pg 93	Sperry #UVP	99
				Sperry #UJ	101
				Fexitron #846	105
				Sperry #SPX 120KV	107
				Sperry #160EA-8	109
				Balteau #140B	111
Branson #303				95	
Krautkramer #USM2				97	
Sperry #UVP				99	
Sperry #UJ				101	
Nortec #NDT-2				81	
Magnaflux #ED-520				83	
Sperry #EM-1500	85				
Sperry #EM-3100	86				
Forster Defectometer #2.164	88				
Parker Research #EC-550	90				

tail rotor drive shaft, tail rotor drive shaft clamps, tail rotor hub assembly and synchronized elevator controls for the UH-1 aircraft. Depth measurements are required on all aircraft. The ideal measurement device must cover a range of 0.001 to 0.250 inch and be accurate to  $\pm 0.005$  inch. Ideally, it should be a noncontact device capable of measuring very narrow surface defects which are difficult or impossible to measure with mechanical indicators (dial indicators are currently used).

A particular application is the rotary-wing head of the CH-47 helicopter. This item is a machined steel forging splined and retained to the rotor drive shaft by a self-locking nut. Inspection of this item illustrates the need for a single device which will work over a wide range. The inspection requirement states - "Damage to the top and bottom surfaces may not exceed a maximum depth of 0.005 inch and a maximum length of 2.5 inches or a maximum depth of 0.010 inch and a maximum length of 1.0 inch. Side surface damage may not exceed a maximum depth of 0.005 inch and a maximum length of 0.625 inch."

Investigation of applicable devices and methods covered such inspection techniques as optical comparitors, dial indicators, electronic indicators and plastic impression.

The optical comparitor provides an accurate and rapid technique for determining indentation depth and width. It operates on the principle of the measurement of a reflected image. The degree of distortion of this image from a reference is proportional to the depth and width of the indentation.

The dial indicator also provides an accurate technique for determining indentation depth and width. A stylus or probe connected to a readout gage or pointer is passed over (in contact with) the surface under examination. A comparison of the deflection of the stylus or probe with the normal surface as a standard provides the depth of the indentation. The measured movement of the stylus holder along a vernier while in the indentation provides the length of the indentation.

The electronic gage provides the most accurate technique for determining indentation surface under examination. Small changes in the surface to probe distance are reflected in changes in capacitance or resistance which when fed through electronic circuitry produce a direct readout on a calibrated meter.

The plastic impression is the simplest technique for determining indentation depth. A hot melt plastic caulking compound is applied to the surface under examination. After solidifying, the compound is removed and the impression measured with a vernier gage or dial indicator.

Of the devices and techniques investigated, two best meet the basic objectives of this study: the optical scratch gage and the plastic impression technique.

Item Name: Scratch Depth Gage

Manufacturer: Micro-Line Division of Bausch and Lomb  
Jamestown, New York 14701

Part/Model No.: 38-19-14

Figure No.: 6

Size: 4 in. x 2 in. x 10 in.

Weight: 2 lb

Power Requirements: Batteries

Cost: \$350.00

Current Users: Present model now obsolete

FSN: None

MIL Spec: None

Operating Environment: Temperature limited to operator tolerance. Operates on battery power.

Method of Operation: The operational principle utilizes a small wire illuminated from behind and projected as an image onto the surface under examination. The image is projected at a sufficient angle of incidence so that it becomes elongated and distorted as a result of a surface blemish. The elongated distortion shadow is enlarged by an objective lens and focused onto a calibrated reticle. Both the depth and width of the enlarged item can be read directly on the scale.

To use this instrument, place it over the indentation in question with the indentation between and parallel to the nylon base pads. Slide the lamp button on to illuminate the indentation and the surrounding surface.

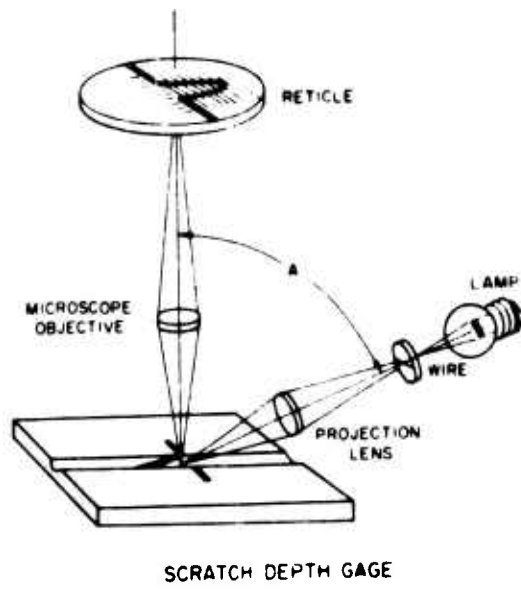
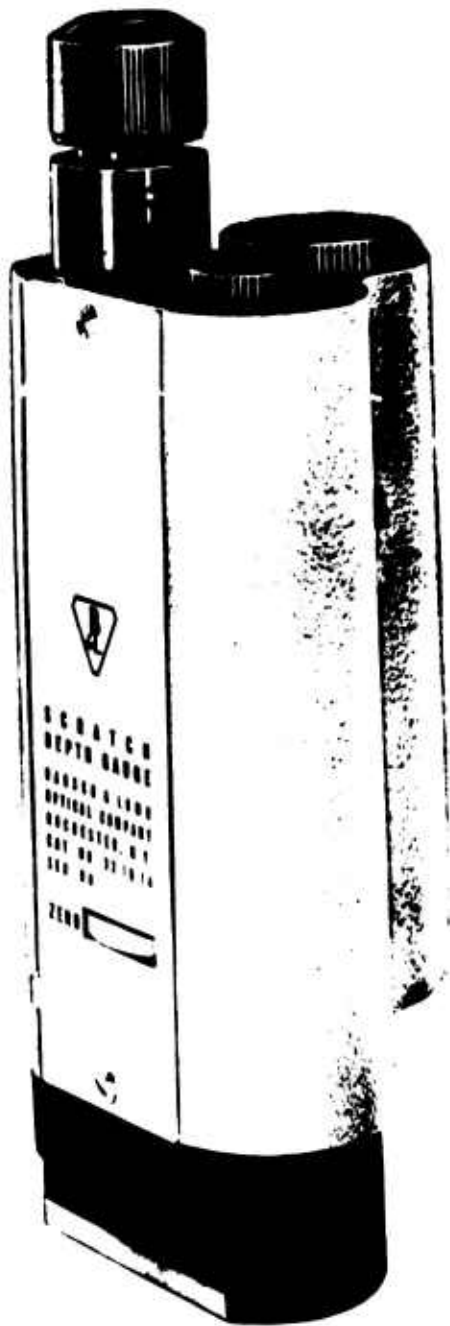

Figure 6. Scratch Depth Gage.

The instrument is then shifted until the image crosses the indentation. By moving the zero control wheel, the straight portion of the shadow image will become centered at the zero mark on the scale. The width and depth may be read directly.

Capabilities/Limitations: This device is capable of measuring indentations on all flat or plane surfaces and with base adapters curved on tabular surfaces. Readout is direct both for width and depth. This device is portable, lightweight and battery powered.

The standard device can measure indentation depths from 0.0002 to 0.016 inch with an accuracy of  $\pm 0.0001$  or 5 percent of the depth, whichever is larger, and it can measure indentation widths from 0.001 to 0.050 inch with an accuracy of  $\pm 0.001$  inch.

This device can be designed with a special calibrated reticle to enable depth and width measurements into an extended range.

Skill/Training Requirements: Operation of this depth gage is simple and straightforward. The indentation image is displayed directly to the viewer, and a readout is obtained by reading a scale. The indentation image must be centered manually; however, the procedure is quite simple.

No specialized knowledge or training is required.

Item Name: Plastic Impression

Manufacturer: USM Corporation, Chemical Division  
Boston Street  
Middleton, Massachusetts 01949

Part/Model No.: Injection Gun: Model 260  
Thermogrip Adhesive: 6368 and 6367

Size: 10 in. x 6 in. x 2 in. (packaged size)      Weight: 0.5 lb

Power Requirements: 60 Hz, 115 volts

Cost: Less than \$15

Current Users: For this application - none

FSN: None                      MIL Spec: None

Operating Environment: Temperature limited to the range of 32°F to 100°F. AC power source must be available.

Method of Operation: The technique heats a cylinder of the polyethylene adhesive to a plastic condition in an electric pistol grip gun. The plastic is then injected onto the area under examination. A hard object such as a block of metal is then pressed against the cooling plastic.

The plastic fills the indentation and cools or solidifies in about 15 seconds. Upon removal from the indentation, this impression is then measured using a dial caliper or dial indicator.

The measured results will give the width and depth of the indentation.

Capabilities/Limitations: This technique is capable of measuring any small blemish, and it is readily removable from the area being examined. It provides a permanent record of the indentation under consideration.

The area being examined must be clean and the metal surrounding the blemish must be at a temperature of 100°F or less in order to prevent the plastic from adhering to the metal.

A 60 Hz, 115 volt power source must be available.

The inaccuracy of the measurement will run as high as 3 percent of the measurement value due to shrinkage of the polyethylene plastic.

Skill/Training Requirements: The performance of this technique requires no specialized training.

## CRACKS

Cracks which develop in the structural and mechanical components of aircraft may, if allowed to progress to the point of critical failure, cause substantial secondary damage and jeopardize the safety of the aircraft and its crew. The problem of cracks is especially acute in helicopters because of the heavy cyclical stress loads and high vibration levels under which major dynamic systems of the aircraft operate. The

magnitude of the problem, in terms of both its frequency and potential consequences, is such that a considerable amount of aircraft inspection time is devoted to searching for cracks in their incipient stages.

Cracks may generally be classified as one of two principal types: (1) fatigue cracks originating from repeated applications of stress, or (2) static cracks developing from one or several exposures to extremely high stress. Both types of cracks often originate from fabrication or processing discontinuities in the material. Of the two, fatigue cracks occur with greatest frequency and are the object of most inspection requirements.

Fatigue cracks normally develop in or adjacent to areas of stress concentration. These may include oil holes, fillets, keyways, splines, and threads, among others. Usually these areas are designed to easily withstand the stresses imposed. Faulty design or manufacture such as oil holes with sharp edges and poorly finished or insufficient fillets often result in a concentrated stress much higher than expected. The presence of any discontinuities in an area of stress concentration greatly increases the possibilities of fatigue failure. The rate of progress of fatigue cracks will vary with the stress conditions. In some cases, crack progression will be quite slow. In others, where high stress loads are repeatedly sustained, particularly in brittle materials, progression of cracks may be virtually instantaneous.

The problems associated with inspection for cracks in aircraft are influenced by such considerations as the material composition of the part, its criticality and location, the frequency and magnitude of stress loads, the origin of the defect (surface or subsurface) and its point of inception. From the standpoint of examining the techniques and devices applicable to inspection for cracks in aircraft, three general problem areas have been established:

1. Surface cracks in nonmetallic materials.
2. Surface cracks in aluminum or magnesium sheet metal structure.
3. Surface or subsurface cracks in major structural forged, extruded or cast components.

## Surface Cracks in Nonmetallic Materials

Surface cracks in nonmetallic materials such as fiberglass, plastic and composites are generally inspected for visually. Since materials of this type are used most often in low-stress, nonstructural applications such as fairings and covers, it is usually acceptable to allow cracks to progress to the point of visual evidence without risk. In applications where the material is structural, i.e., load-carrying, the inspection requirement may be more stringent, extending frequently to an examination for fine microscopic surface cracks.

The skin of the CH-47 main rotor blade is an example of a load-carrying, nonmetallic material for which visual enhancement techniques such as dye penetrant or fluorescent penetrant may be desirable for inspection of cracks in critical locations. Devices which aid visual examination in areas of restricted access may be useful in either application.

## Surface Cracks in Sheet Metal Structure

Surface cracks in aluminum or magnesium sheet metal structure are usually inspected for visually. In areas where sheet metal is used as secondary structure (such as cowling or fairing) or where the structure is not heavily stressed (such as most sections of the fuselage skin), it is usually acceptable to allow cracks to progress to the point of visual evidence without risk. Infrequently, it may be desirable to augment visual inspection with such methods as eddy current or ultrasonics when known points of crack development are concealed by fasteners or protective coatings. Visual enhancement via dye penetrant or fluorescent penetrant may be useful in such applications as well.

Inspection for cracks is much more critical when the sheet metal is used as primary structure such as stringers, stiffeners and frames. Here again, however, visual inspection techniques are most often employed and are generally adequate. Because of the redundant nature of such structure, the first visual evidence of a crack usually provides ample warning and allows repairs to be made long before any significant weakening of the structure occurs. In fact, defects occurring simultaneously in several such members would normally not impair structural integrity significantly.

Visual inspection techniques may not be adequate, however, in certain critical locations, especially those where high stress concentrations develop such as the structure comprising or surrounding major fuselage fittings and attachment points. Because cracks in such areas may propagate very rapidly, it is frequently desirable to detect them before they have progressed to the point of visual evidence. Cleaning and magnification of the area will usually reveal the presence of microscopic surface cracks adequately. Dye penetrant or fluorescent penetrant may also be used effectively in applications of this type. Inspection techniques such as eddy current or ultrasonics may be useful when the area to be inspected is concealed or not accessible to a visual examination, particularly in the proximity of fasteners, rivets, etc.

### Surface and Subsurface Cracks in Major Structural Components

Inspection for surface cracks in major structural (high load-carrying) forged, extruded or cast components of aluminum, steel or magnesium construction is normally accomplished visually or via dye penetrant technique. Fittings, beams and landing gear wheels are common components of this type. In highly critical components subject to heavy stress loads, it is often necessary to inspect for microscopic or submicroscopic cracks emanating at or below the surface of the part. For less critically loaded parts, inspection for microscopic surface cracks is usually acceptable.

Some of the techniques which may be employed for detecting minute surface and subsurface cracks are eddy current, ultrasonics and x-ray. Fluorescent penetrant may be effective where examination for surface cracks alone is required.

### Flexible Fiberscopes

Fiber optics is based on (1) the ability of smooth fibers of transparent materials, such as glass, to conduct light with high efficiency by means of multiple internal reflections, and (2) the ability of each fiber in any array or bundle to conduct this light independently of its neighbors.

In principle, the conditions for total reflection exist at any smooth interface between two transparent media having different indices of refraction, for example, between glass and air. Thus, a smooth glass fiber in air should conduct light efficiently. In practice, however, minute defects and contamination by grease, dust, etc., at the fiber surfaces interfere with the total reflection phenomenon by absorbing or scattering a fraction of the incident light. In the case of prisms, which depend on total internal reflection, this is not generally a problem since, at most, only a few reflections are involved. In a fiber, however, each ray of light may be reflected thousands of times in its passage through it so that the minute losses at each reflection can accumulate to a substantial portion of the total input light. Thus, freshly drawn, uncoated glass fibers rapidly lose their initial transmission efficiency because of surface contamination.

Even if it were possible to adequately protect uncoated fibers from contamination, they would still prove unsuitable for most applications because of the leakage of light from one fiber to the next. This form of light leakage is sometimes called "optical cross-talk".

Only through the use of a transparent dielectric coating of lower refractive index did it prove possible to avoid cross-talk and retain high transmission qualities. Today glass fibers are coated with a layer of lower refractive index glass. The use of glass coating, or "cladding" as it is often called, not only produces a fiber with good optical properties, but it also makes possible fiber optic devices in which fibers are fused together by heating, the glass coating serving as the bonding cement.

Flexible fiberscopes are one of the many devices spawned by the development of glass "cladding". Fiberscopes offer a solution to problems of viewing remote and inaccessible areas. Typically, they are used to inspect the interiors of boilers, castings, pumps, engines, etc.

A fiberscope consists of thousands of glass fibers with an objective lens at one end and a magnifying eyepiece at the other. The objective lens focuses the image on the far end of the fiber bundle. Internal reflections then transmit the image to the eyepiece where it is magnified for viewing.

A special fiber bundle transmits light to the viewing area. And this is cold light because a fiberscope brings neither heat nor electrical connections to the viewing area.

Item Name: Fiberscope

Manufacturer: American Optical Corporation, Southbridge, Massachusetts 01550

Part/Model No.: FS-100

Figure No.: 7

Size: 18 in. x 14 in. x 6 in. (packaged size) Weight: 3.5 lb

Power Requirements: Two each "C" size batteries

Cost: Approximately \$300.00

Current Users: Commercial companies including:

Pratt and Whitney Aircraft  
Avco Lycoming  
McDonnell Douglas

FSN: None

MIL Spec: Unknown

Operating Environment: Temperature limited only to operator tolerance. Power and light sources are self-contained. Does not introduce heat or electrical connections in area being inspected.

Method of Operation: Fiberscope gooseneck is fed through small openings and manipulated to alter the field of view. A switch for the self-contained light source is located on the operator's hand grip. When switched on, light travels via glass fibers, illuminates the area being inspected, is reflected and carried back to operator's eyepiece via still other glass fibers. The eyepiece offers seven-power magnification of the area being viewed.

Capabilities/Limitations: Capable of being inserted into areas as small as 0.315 inch in diameter and 34 inches deep. Goose-neck is flexible and may be bent into desired shape provided inside bend radii are no less than 1.750 inches. Field of view is 60 degrees with fixed focus. Depth of focus is 0.750 inch to infinity. The device is hand held and extremely portable.

Skill/Training Requirements: The area being viewed is displayed directly to the viewer, and no interpretation of the display is required. Focal length of the device is fixed, and no adjustments are required. Use of the device requires no specialized training. The operator, however, must have knowledge of the hidden areas being viewed to aid in aiming the flexible gooseneck.

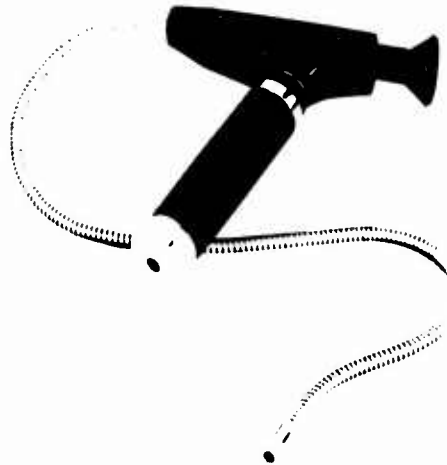

Figure 7. FS-100 Fiberscope.

Item Name: Peeperscope

Manufacturer: American Optical Corporation, Southbridge, Massachusetts 01550

Part/Model No.: PS-3-18

Figure No.: 8

Size: 13 in. x 9 in. x 1 in. (packaged size) Weight: 0.5 lb

Power Requirements: None

Cost: Approximately \$40.00

Current Users: Commercial companies including:

Pratt and Whitney Aircraft  
Avco Lycoming  
McDonnell Douglas

FSN: None

MIL Spec: Unknown

Operating Environment: Temperature limited to operator tolerance. Uses no electrical power. May be safely used in hazardous gas environments.

Method of Operation: Peeperscope gooseneck is fed through small openings and manipulated to alter field of view. The area being inspected must be lighted by an independent source. The viewed image is transmitted to the operator's eyepiece via flexible glass fibers. Proper focus is achieved by adjusting (rotating) the objective lens. The eyepiece offers seven-power magnification of the area being viewed.

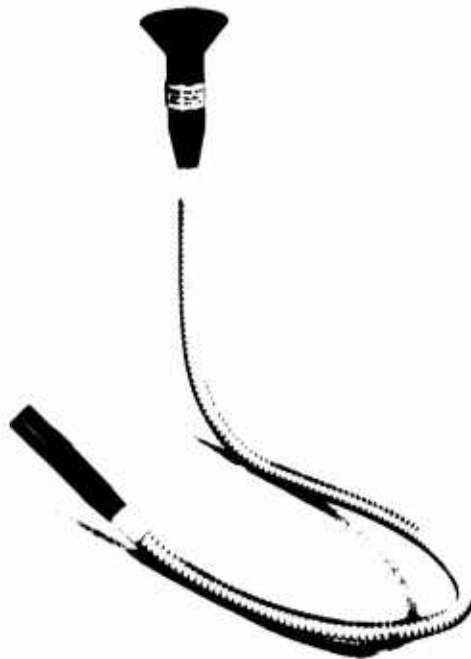

Figure 8. Peeperscope, Model PS-3-18.

Capabilities/Limitations: Capable of being inserted into areas as small as 0.500 inch in diameter and 18 inches deep. Gooseneck is flexible and may be bent into desired shape provided inside bend radii are no less than 1.750 inches. Areas being viewed must be lighted by independent light source. The device is hand held and is extremely portable.

Skill/Training Requirements: The area being viewed is displayed directly to the viewer, and no interpretation of the display is required. Focal length must be adjusted; however, procedure is same as with widely used binoculars, cameras, etc. No specialized training is required; however, operator must have knowledge of hidden areas being viewed to aid in aiming the flexible gooseneck.

### Fluorescent Penetrant Inspection

Liquid penetrant inspection is a process for locating defects that are open to the surface in solid, essentially nonporous materials by observing the presence of entrapped highly visible liquids. These liquids penetrate surface openings, remain there during a rinsing operation, and then emerge to the surface after a thin coating of absorbent material, which acts as a developer, is applied to the article under test. The visibility of the trace amount of liquid withdrawn from a defect into the developer is greatly enhanced by a special additive in the penetrant. The additive may be either a very bright dye, the color of which contrasts with that of the absorbent coating, or a compound that strongly radiates visible light under invisible ultraviolet illumination.

Liquid penetrant inspection has become popular throughout the aerospace industry, and today is probably the single most widely employed nondestructive testing method. It is popular because it has a wide range of applications, is comparatively easy to employ, and requires only a moderate amount of special training or technical ability for its routine use. Within its normal application, penetrant inspection has proved to be both sensitive and reliable in the hands of properly trained and experienced technicians. Its fundamental limitation is, of course, that it is useless for detecting flaws that are present within the body of an article, but not open to its surface.

Item Name: Water Washable Fluorescent Penetrant

Manufacturers: Sperry Products Division  
Danbury, Connecticut 06810

Belmont Chemicals, Incorporated  
Los Angeles, California 90022

Magnaflux Corporation  
Chicago, Illinois 60656

Met-L-Check Company  
Englewood, California 90310

Shannon Luminous Materials Company  
Hollywood, California 91646

Testing Systems, Incorporated  
Greenside, Pennsylvania 19038

Turco Products Division  
Wilmington, California 90744

Part/Model No.: MIL-I-25135C, Groups IV, V, VI, and VII

Figure No.: 9

Size: Typically, Fluorescent Penetrant is available in 12-ounce spray cans, pint cans, gallon cans, 5-gallon cans, and 55-gallon barrels.

Weight: Unknown

Power Requirement: All fluorescent penetrant inspection systems require use of a long wave ultraviolet light source (black light). Power requirements for these items are presented on pages 76 and 78.

Cost: Typically, the cost per gallon can of water washable fluorescent penetrant ranges from \$6.50 to \$16.00, depending on the sensitivity group number. Group IV is least expensive and Group VII the most expensive. Unit cost is lower if purchased in larger containers.

Current Users: U.S. Air Force  
U.S. Navy  
Commercial Airlines  
Commercial Manufacturing Companies

FSN: Unknown      MIL Spec: MIL-I-25135C

Operating Environment: Recommended temperature for parts being inspected is between 60°F and 90°F. In general, penetrants are not useable below 40°F or above 120°F.

Method of Operation: Water washable fluorescent penetrants are available in several different sensitivity groups: Groups IV through VII. The higher the group number, the greater the sensitivity. For a given inspection situation, the sensitivity performance of the penetrant must be sufficient to do the job, but not excessive so that unwanted and nonsignificant indications are produced. Typically, water washable fluorescent penetrants involve use of a basic six-step process:

1. Cleaning of the article to be inspected.
2. Application of the penetrant.
3. Rinsing away of excess penetrant.
4. Application of developer to the surface of the article.
5. Visual inspection of the article under black light and interpretation of indications.
6. Post-inspection removal of residue materials.

Cleaning is important because any contaminants left on the test object will prevent the penetrant liquid from entering a defect, and the inspection will be ineffective. Some common cleaners are detergents, organic solvents, vapor degreasing, descaling solutions, paint remover, ultrasonic cleaning, and abrasive blasting.

Application of penetrant may be by spraying, brushing, or dipping. The coating must be kept wet for a prescribed minimum time (dwell time), during which the material migrates into

surface flaws. Temperature of the test article affects penetrating action, and the optimum range is 60°F to 90°F.

After the penetrant is allowed to dwell on surface of test object for prescribed time, the excess amount is rinsed away by flushing with water. Failure to remove all excess penetrant will leave a confusing background, which will interfere with accurate defect interpretation. Moreover, overwashing may eliminate legitimate flaw indications. After rinsing, the test surface is dried.

Three types of developers may be used with water washable penetrants. Dry developers are usually applied by dipping the article into a bin of loose fluffy powder, or by gently blowing the powder onto the article with soft hand-squeezed rubber "puff bottles". Wet aqueous developers are applied by dipping or by spraying. After the wet aqueous developer has been applied, the article requires some time to dry. Wet nonaqueous developers are also dipped or sprayed, but they dry very rapidly. The length of time any type of developer is allowed to remain on the test article before inspection begins is called the development time. This may range from a few minutes for large flaws to an hour or longer for very small flaws.

The fluorescent penetrant process reveals flaws as glowing marks under ultraviolet light. These light sources may be highly portable (battery operated) or semiportable (independent AC power source). The former type of lamp is discussed in another section of this report.

After an article has been examined, it is usually necessary to remove all residual inspection materials and restore the original surface protection scheme, i.e., paint, plating, etc.

Capabilities/Limitations: The most important advantage of fluorescent penetrant inspection is its relative simplicity and economy. The method will accommodate articles of many sizes and shapes. Many penetrant materials (with varying sensitivity) are available to suit a wide range of special purposes. There is less of a tendency to give false indications than many competing techniques. The principal limitation of fluorescent penetrant is that it can detect only those discontinuities having an opening to the surface. Surface treatments such as paint or plating may conceal flaws in the test

object's basic material. Porous surfaces tend to absorb penetrants, thus producing an undesirable background which will mask defect indications. The process is somewhat more messy than most others.

Skill/Training requirements: The inspector must be aware of the capabilities and limitations of penetrants, and he must have knowledge of the article to be inspected. He must know the kinds of flaws to expect, their likely locations, and the likelihood that an unusual flaw may occur. Moreover, he must be able to discriminate between a genuine flaw indication and any spurious, or false, indications which may occur due to improper prior treatment, or peculiarities in either geometry or surface properties of the inspection object. Both formal instruction and on-the-job training are necessary.

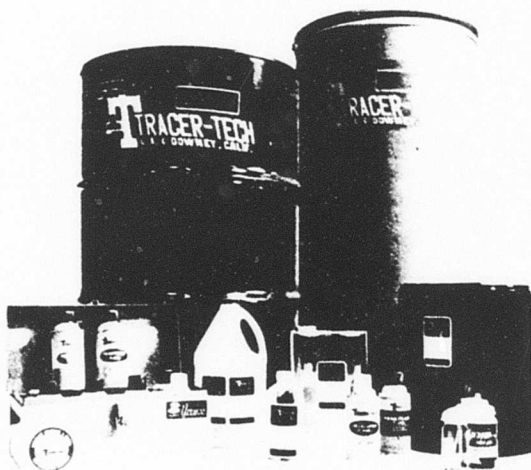

Figure 9. Typical Fluorescent Penetrant Containers.

Item Name: Cordless 4-Watt Black Light

Manufacturer: Ultra-Violet Products, Incorporated  
San Gabriel, California 91778

Part/Model No.: M-16 Blak-Ray

Figure No.: 10

Size: 6.75 in. x 4.125 in. x 1.875 in. Weight: 1.5 lb (with battery)

Power Requirements: Operates from nickel cadmium battery pack. Standard recharger operates on 115 volt AC. Can special order 220 volt AC or 12 volt DC recharger.

Cost: Approximately \$80.00

Current Users: U.S. Air Force  
Commercial Companies

FSN: 6635-760-5448

MIL Spec: None

Operating Environment: Limiting factors are fluorescent penetrant requirements, not ultraviolet light environmental capabilities. Penetrant requires temperature of 60°F to 90°F and relatively low humidity.

Method of Operation: The M-16 lamp is a hand-held cordless black light source used to illuminate areas suspected of having defects after the areas have been treated with fluorescent penetrant, fluorescent oil, or fluorescent tracer additive. These processes are more fully described elsewhere in this report.

When defects are present, the black light will cause them to be seen as glowing marks. For best results, visible light should be minimized in the test area.

Capabilities/Limitations: The M-16 Blak-Ray is a long wave lamp having a wave length of 366 nanometers. Typical intensity measurement is 230 microwatts per square centimeter at 6 inches distance (with filter). The filter absorbs visible light and transmits ultraviolet. The tube is rated at 4,000-6,000 hours of use. A self-contained battery operates for approximately 45 minutes between recharges. Fourteen to sixteen hours are required to fully charge a discharged battery.

Skill/Training Requirements: The cordless ultraviolet lamp does not require great skill or experience to operate. However, the lamp is only part of complete inspection systems

which are much more demanding in this regard. Skill and training requirements are given elsewhere in this report for systems involving fluorescent penetrants, fluorescent oils, and fluorescent tracer additives.



Figure 10. Cordless Black Light, M-16 Blak Ray.

Item Name: Cordless 6-Watt Black Light

Manufacturer: Ultra-Violet Products, Incorporated  
San Gabriel, California 91778

Part/Model No.: ML-49 Blak-Ray

Figure No.: 11

Size: 8.5 in. x 7.25 in. x 2.375 in.

Weight: 4.5 lb (including  
batteries)

Power Requirements: 2 each 6 volt lantern batteries (replaceable)

Cost: Approximately \$50.00 (including batteries)

Current Users: Commercial Companies

FSN: None

MIL Spec: Unknown

Operating Environment: Limiting factors are a fluorescent penetrant temperature of 60°F to 90°F and relatively low humidity.

Method of Operation: The ML-49 lamp is a hand-held cordless black light source used to illuminate areas suspected of having defects after the areas have been treated with fluorescent penetrant, fluorescent oil, or fluorescent tracer additive. When defects are present, the black light will cause them to be seen as glowing marks. For best results, visible light should be minimized in the test area.

Capabilities/Limitations: The ML-49 Blak-Ray is a long wave lamp having a wave length of 366 nanometers. Typical intensity measurement is 440 microwatts per square centimeter at 6 inches distance (with filter). The filter absorbs visible light and transmits ultraviolet. Two self-contained batteries will provide approximately 10 hours of life. When discharged, batteries are discarded and replaced. The ML-49 incorporates a built-in flash light (visible light). The single control switch prevents simultaneous illumination of the visible light and ultraviolet light lamps.

Skill/Training Requirements: The cordless ultraviolet lamp does not require great skill to operate. However, the lamp is only part of complete inspection systems which are much more demanding in this regard. Skill and training requirements are commensurate with systems involving fluorescent penetrants, fluorescent oils, and fluorescent tracer additives.

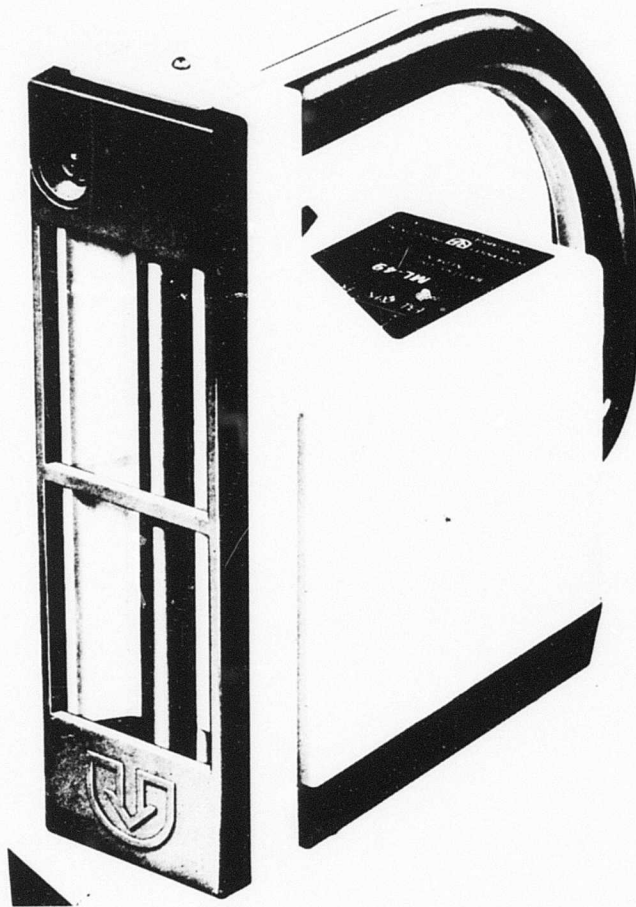

Figure 11. Cordless Black Light, Blak-Ray ML-49.

### Eddy Current Testing

Eddy current inspection is a method of locating surface or sub-surface flaws in electrically conductive materials, and evaluating such material characteristics as hardness, heat-treat condition, and other metallurgical conditions.

Essentially, eddy current testing consists of observing the interaction between electromagnetic fields and metals. In a basic scheme, currents are induced to flow in the piece being tested by a coil of wire carrying an alternating current.

As it enters the part, the electromagnetic energy produced by this coil is partially absorbed and converted into heat through the effects of resistivity (and hysteresis as well if the conductor is magnetic). Part of the remaining energy is "reflected" back to the test coil, its electrical characteristics having been changed in a manner determined by the properties of the specimen being tested. Consequently, the current flowing through the probe coil is the source of the information describing a part's quality, properties, and characteristics. These currents are compared with those flowing in a "standard" or acceptable sample. If there is a deviation which exceeds an established limit (determined by theoretical and experimental considerations of the particular test), an undesirable condition is indicated.

Eddy currents are also interrupted by discontinuities or boundaries. As a consequence, the detection of defects (cracks, holes, lumps, seams, or porous areas) in metal parts of relative uniform shape has been one of the principal applications for the technique.

As a nondestructive testing tool, eddy-current inspection complements the other standard methods for detection of (1) surface and subsurface flaws, (2) irregularities in material structure, and (3) variation in chemical composition in metallurgy. Compared with liquid penetrants, eddy-current methods are not as sensitive to small, open flaws; however, they have the advantage over liquid penetrants in that they are faster, they do not require a cleanup operation, and, especially, they can respond to subsurface flaws. Compared with the magnetic-particle method, eddy-current methods are not as sensitive to small flaws, but they have the advantage of being effective with both ferromagnetic and nonferromagnetic metals. Ultrasonic methods are superior to eddy-current methods for resolving small flaws and detecting flaws located well below the surface; however, eddy-current methods do not require mechanical coupling to the specimen as does ultrasonics. Compared with radiographic methods, eddy-current techniques are faster but generally not as sensitive to small, deep subsurface flaws.

Some of the inherent limitations of eddy-current test methods are (1) depth of inspection below the material surface is limited depending upon the test frequency, (2) eddy currents

are influenced by many material variables, which often yield ambiguous test results, and (3) most test instruments must be manned by well-trained operators.

Eddy current instruments present defects via meter readout and/or audible alarm. A certain amount of reliance on operator experience, skill, and judgement is necessary for interpretation of meter readout and for adjusting the threshold circuitry that triggers the alarm. The operator's experience must allow him to differentiate between signals that represent an unacceptable deviation from a normal specimen and those that do not. Specialized training is required for persons expected to make varied and unique inspections (not repetitive). Once a setup is developed and proven for a repetitive application, however, eddy current inspection systems do not require highly skilled operators.

Item Name: Eddy Current Crack Detector

Manufacturer: Nortec Corporation  
Richland, Washington 99352

Part/Model No.: NDT-2 Figure No.: 12

Size: 5 in. x 4 in. x 4 in. Weight: 3 lb

Power Requirement: 2 each 6.75 volt mercury batteries

Cost: Approximately \$700.00

Current Users: U.S. Navy  
U.S. Air Force  
Commercial companies

FSN: None MIL Spec: Unknown

Operating Environment: Limits of normal operating environment are 0-120°F and 85 percent relative humidity.

Method of Operation: The sensing element cord is connected to the meter unit and the sensing element is placed on or in close proximity to a specimen of known good quality.

When the instrument is turned on, eddy currents are generated in the specimen by AC current flowing in the sensing element

(or probe). The probe forms one leg of a bridge circuit which is balanced by means of controls on the front of the instrument. Once balanced, the probe is moved to a test specimen and positioned in the same manner as with the standard specimen. If the test specimen contains a discontinuity in the area being inspected, an unbalance of the bridge occurs. This unbalance causes a meter deflection and the amount of deflection indicates relative severity of the discontinuity.

Capabilities/Limitations: Capable of detecting cracks as small as 0.005 inch deep by 0.030 inch long under normal conditions. Search depth is shallow (approximately 0.050 inch) and may be made through paint, plating, etc. No "lift off" (clearance) compensation is possible with the instrument. Results are equally good on steel and nonmagnetic metals (not suitable for use on nonmetallic materials). Crack indications are clearly recognizable even when located at a steel to aluminum interface (doubler). Edge effects have been suppressed. A variety of probe shapes are available for fastener hole inspection in addition to flat surface inspection. The instrument is completely portable, and the inspection process is rapid. Battery life is approximately 80 hours.

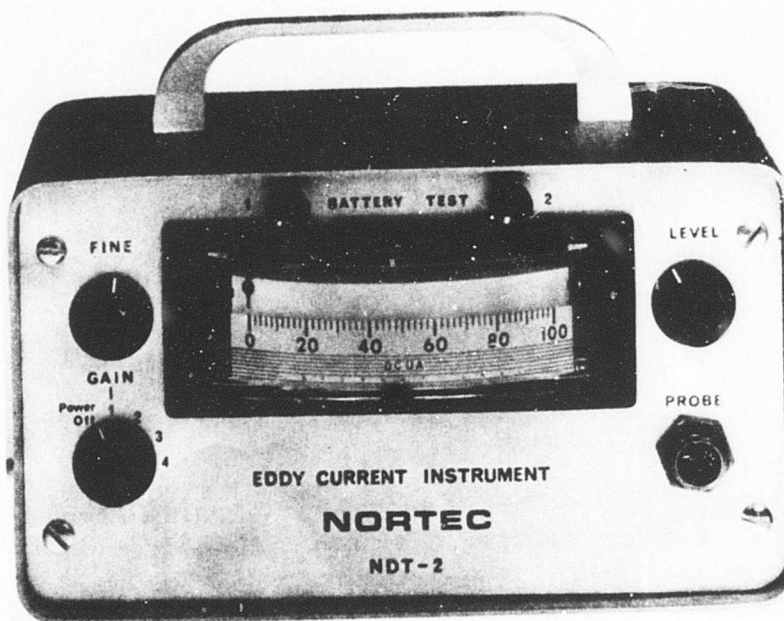

Figure 12. Nortec Eddy Current Instrument.

Item Name: Eddy Current Crack Detector

Manufacturer: Magnaflux Corp.  
Chicago, Illinois 60656

Part/Model No.: ED-520 Figure No.: 13

Size: 9 in. x 6 in. x 4-3/4 in. Weight: 6 lb

Power Requirements: 2 each rechargeable nickel cadmium batteries

Cost: Approximately \$900.00

Current Users: U. S. Air Force  
Commercial companies

FSN: 6635-167-9826 Mil Spec: Unknown

Operating Environment: Limits of normal operating environment are 0-120°F and 85% relative humidity.

Method of Operation: The probe is connected to the front panel of the instrument and the "Mode" switch turned to the "LO" position. "Lift-off/Frequency" and the "Balance" controls are set to zero. Probe is placed on surface of test specimen and "Balance" control adjusted so that the meter pointer is on scale. This calibration process may need to be repeated a number of times with successive advancements of the "Lift-off/Frequency" control until the meter pointer comes on scale. Maximum sensitivity is achieved with the "Lift-off/Frequency" control set at the lowest setting for which lift-off compensation (meter pointer on scale) can be achieved. With the instrument properly calibrated as described, the probe is moved about the surface to be inspected, and cracks, fractures, breaks, or other flaws in nonmagnetic metals will generally be recognized by a downward meter needle deflection. Similar defects in magnetic metals will generally be recognized by an upscale meter deflection.

Capabilities/Limitations: The ED-520 instrument is a highly portable, solid-state device which will locate surface and near surface defects in nonmagnetic materials. Surface defects may also be detected in magnetic materials where permeability is relatively constant throughout the test area. The unit features a probe which is tuned to the specific geometry, conductivity and permeability of the test specimen, through adjustment of the variable "Lift-Off/Frequency" control (55 to 200 KHZ). Limit for continuous battery operation is 24 hours. Batteries may be recharged via built-in transformer type charger.

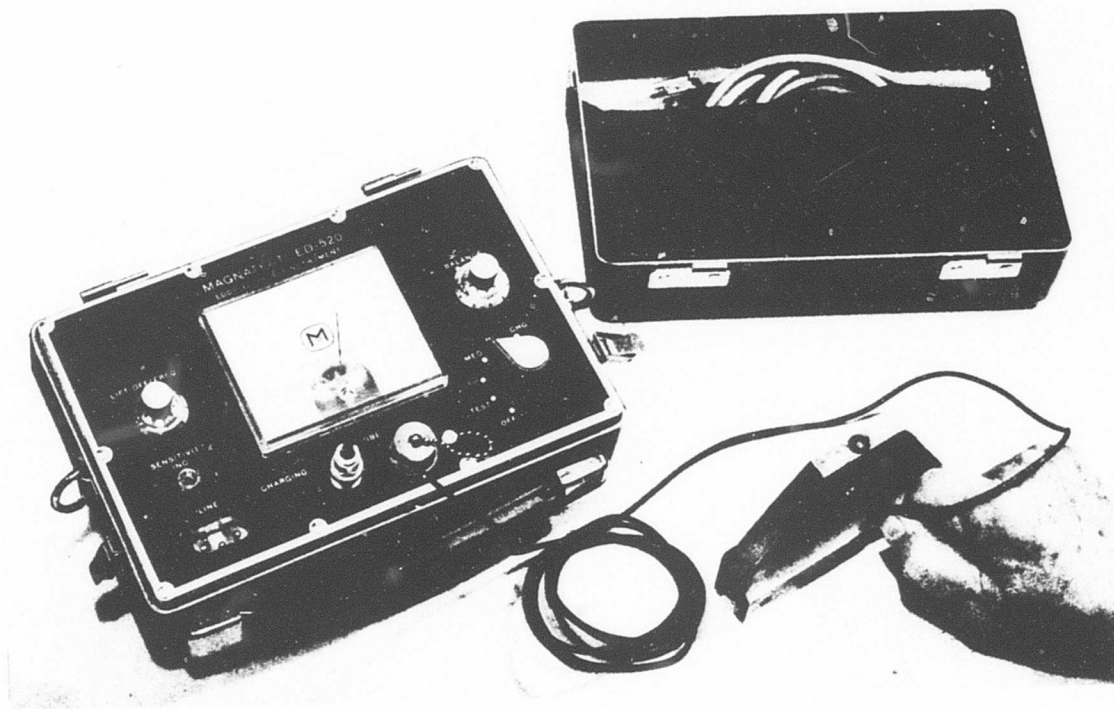

Figure 13. Magnatest ED-520 Eddy Current Instrument.

Item Name: Multi-Purpose Eddy Current Instrument

Manufacturer: Sperry Division  
Automation Industries  
Danbury, Connecticut 06810

Part/Model No.: EM-1500 Figure No.: 14

Size: 11 in. x 7 in. x 7.5 in. Weight: 5 lb

Power Requirements: 6 each "D" size batteries

Cost: Approximately \$1200.00

Current User: U.S. Air Force  
Commercial companies

FSN: None MIL Spec: Unknown

Operating Environment: Limits of normal operating environment are 0-120°F and 85 percent relative humidity.

Method of Operation: The probe is connected to the instrument via a receptacle on the meter panel. Test frequency is determined by plugging an oscillator tank circuit into a front panel connector. Several tank circuits are available within the specified frequency range. Balancing is achieved by plugging in a reference coil (also into front panel) which corresponds to the particular probe or coil being utilized in the inspection. This provides maximum versatility, since probes designed for single probe instruments can be used by plugging in a reference coil which is equal in impedance to the test probe. With this feature, differential or absolute tests can easily be achieved. "Lift-Off" compensation is accomplished with one control without a corresponding change in frequency. A 360° phase control allows setup for optimum lift-off compensation, amplitude or phase sensitive indications. Once setup is complete, the probe is rested upon or in close proximity to the test specimen and meter pointer observed. Any discontinuities in the area being inspected will produce a meter deflection. The amount of deflection indicates relative severity of the discontinuity.

Capabilities/Limitations: Frequency range is from 1 KHZ to 1 MHZ by means of plug-in frequency modules. This wide range and the ability to use virtually any probe design make this instrument practical for many applications. These include crack detection, relative conductivity measurements, heat damage detection, metal separation, corrosion detection, metal thickness measurements, and paint thickness measurements. Battery life is estimated to be in excess of 100 hours for continuous operation.



Figure 14. Multitest EM-1500 Eddy Current Instrument.

Item Name: Portable Eddy Current Crack Detection Instrument

Manufacturer: Sperry Division  
Automation Industries  
Danbury, Connecticut 06810

Part/Model No.: EM-3100

Figure No.: 15

Size: 11 in. x 7 in. x 7.5 in.

Weight: 7 lb

Power Requirement: Two each "D" size batteries

Cost: Approximately \$950.00

Current Users: U.S. Air Force  
Commercial companies

FSN: None

MIL Spec: Unknown

Operating Environment: Limits of normal operating environment are 0-120°F and 85 percent relative humidity.

Method of Operation: The probe cord is attached to the instrument front panel. Instrument is balanced by placing probe on test specimen and successively adjusting the "X" and the "R" control knobs until meter pointer is on scale for each. Next the probe is lifted off the test specimen 0.010 inch to 0.020 inch and rebalanced using the phase control. Lastly, the probe is removed from the specimen and again rebalanced using the lift-off control. Sensitivity may be set at any time by a control calibrated in crack depth for full-scale deflection. When a defect is under the probe, an adjustable threshold circuit triggers an audible alarm if the defect exceeds a preset trigger level.

Capabilities/Limitations: The EM-3100 is designed for the detection of defects open to the surface or burnished over to a depth of 0.002-0.003 inch. Cracks as shallow as 0.005 inch deep can be measured. It also reacts to shallow laminations such as those caused by folds. It can be used on all conductive materials without changing probes. It is battery powered and highly portable. Battery life is approximately 80 hours.

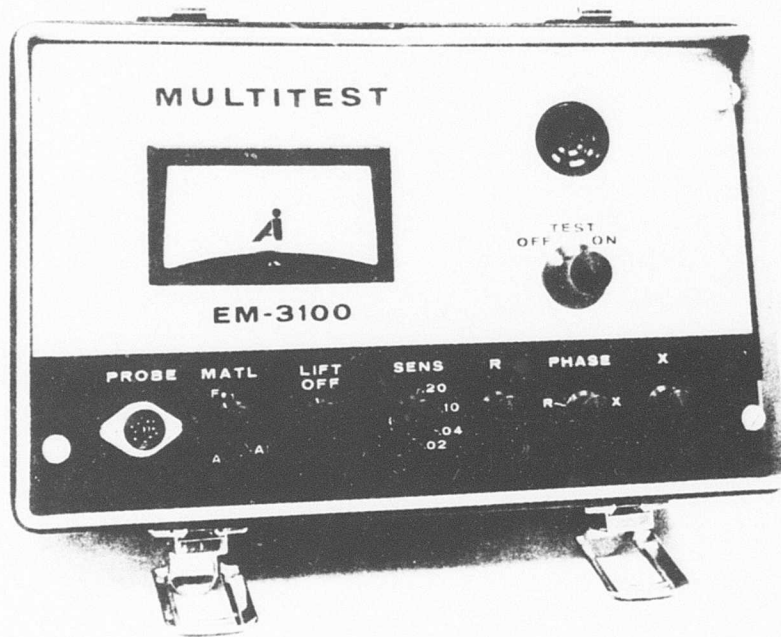

Figure 15. Multitest EM-3100 Eddy Current Instrument.

Item Name: Defectometer

Manufacturer: Institute Dr. Forster  
West Germany

Part/Model No.: 2.164

Figure No.: 16

Size: 11 in. x 8 in. x 5.5 in.

Weight: 6 lb

Power Requirements: 8 each 1.5 volt batteries

Cost: Approximately \$1,200.00

Current Users: Commercial companies including:

Pratt & Whitney Aircraft (USA)  
Snecma (France)  
Rolls Royce (Britain)

FSN: None

MIL Spec: Unknown

Operating Environment: Limits of normal operating environment are 14°F to 104°F.

Method of Operation: The test coil of a probe carries high-frequency alternating current, and the electrical characteristics (impedance) of the coil are influenced by the magnitude of eddy currents produced in the test specimen. When testing, the probe is passed over the surface of a metal specimen. If defects are present, the eddy current distribution is upset at the defective points. This causes a change in coil impedance which, in turn, is a measure of the defect severity. Listed below are devices located on the test set along with a brief description of their function:

- meter - for direct indication of defect depth
- control knob - for "lift-off" compensation
- control knob - for setting electrical zero
- control knob - for setting sensitivity
- push button - for checking battery charge
- 3 push buttons - for selecting respective test frequency for "NFe", "Fe", or "Aust."
- push button - for switching signal lamp and defect response threshold on or off
- control knob - for setting defect response threshold
- red signal lamp - for indicating when defect depth (previously set) is being exceeded
- socket - for attachment of probe cable
- socket - for signal output to peripheral equipment such as recorder, external signal lamp, external acoustical signaling device, etc.

Capabilities/Limitations: The Defectometer is a highly portable device for testing the surfaces of electrically conductive materials having a conductivity between 0.5 and 60 milliohms per square millimeter. The set is suitable for detecting cracks and laps extending up to the surface. Defect presentation via a meter is both qualitative and, subject to certain limitations, quantitative. Test results are good even if the specimen has a thin covering layer such as anodized oxides. Battery life is estimated at 250 hours for continuous service or 500 hours for interrupted.

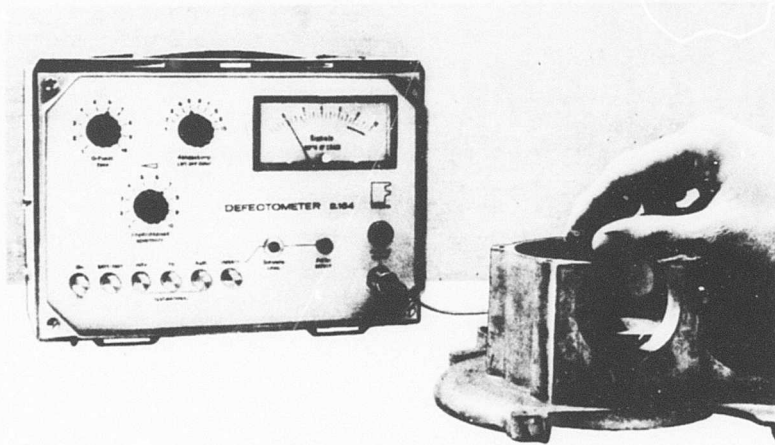

Figure 16. Defectometer Eddy Current Instrument.

Item Name: Audio Probe

Manufacturer: Parker Research  
Dunedin, Florida 33528

Part/Model No.: EC-550

Figure No.: 17

Size: 0.750 in. dia. x 5 in. long  
(less tip)

Weight: 0.5 lb

Power Requirements: One each 9.8 volt mercury battery

Cost: Approximately \$260.00

Current Users: U.S. Navy  
Commercial companies

FSN: None

MIL Spec: Unknown

Operating Environment: Limits of normal operating environment are 0-120°F and 85 percent relative humidity.

Method of Operation: To inspect for cracks in either ferrous or nonferrous material, the earphone is placed in operator's ear and plugged into the instrument. This turns the audio probe on. The sensing tip of the instrument is placed on the material to be inspected. For nonferrous material, the sensitivity control is adjusted to obtain a tone and backed off until the tone is just lost. As the probe is moved over the test area, a crack will produce a loud, positive tone. The readout procedure for ferrous material is just the opposite. The sensitivity control is adjusted to obtain a tone, backed off until tone is lost, then carefully reversed until tone just appears again. As the probe is moved over test specimen, a crack will be indicated by a loss of tone.

Capabilities/Limitations: The Audio Probe is an extremely portable, self-contained eddy current inspection instrument. The probe will detect cracks in both ferrous and nonferrous materials. By the comparative method, it will also identify heat damaged metal, detect heat treat variation, and measure nonconductive coating thicknesses over metal surfaces. The audio probe and sensing tip are quite sensitive to tipping from the position in which the sensitivity control was adjusted. A low charge battery condition is indicated by reduced sensitivity and tone volume. The operator must be experienced enough to recognize this condition for what it is. Battery replacement requires use of a soldering gun.

Skill/Training Requirements: The Audio Probe was designed essentially to provide limited nondestructive testing capabilities to basically nontechnical inspection personnel. Only one control knob must be adjusted to match the electronic circuitry to the material being inspected.

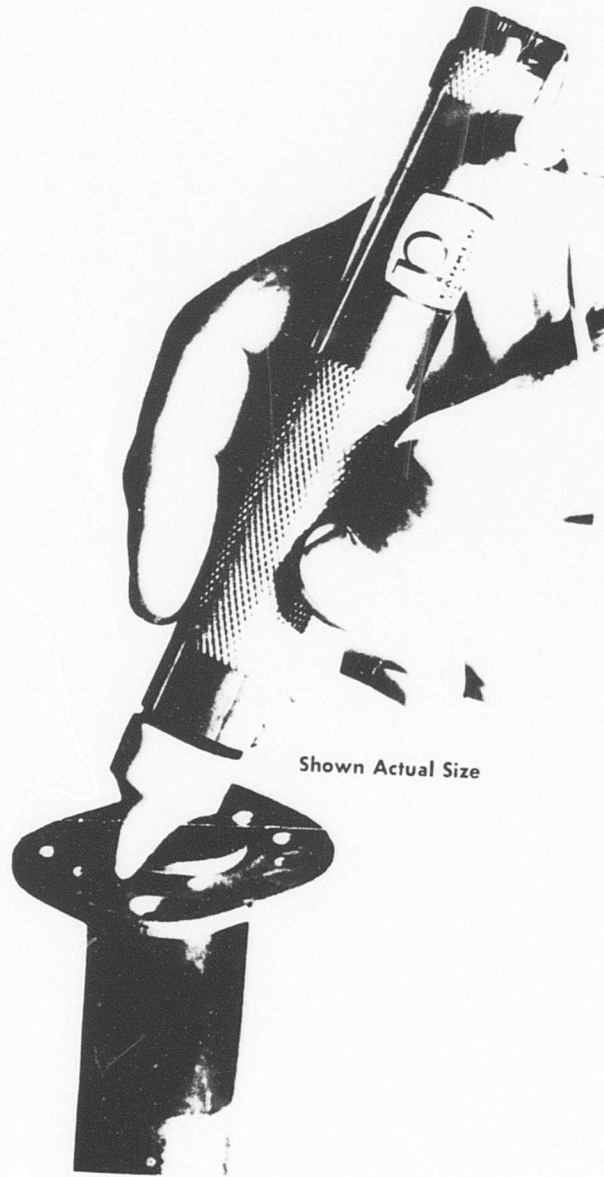

Figure 17. Audio Probe Eddy Current Instrument.

## Ultrasonic Test Equipment

The term "ultrasound" refers to sound waves having a frequency greater than 20,000 cycles per second, roughly the upper limit of sound frequencies to which the human ear responds. "Ultrasonics" refers to the body of scientific knowledge and practical lore associated with the generation, propagation, detection, and use of ultrasound.

Ultrasonic inspection uses a high frequency sound wave as a means of detecting discontinuities in parts. A pulser in the ultrasonic instrument sends an electrical impulse to a transducer in the search unit (piezoelectric material). The transducer changes the electrical impulse into mechanical vibrations and sends them out through the material under test. Any marked change in acoustic properties, such as a flaw or interface in the material, will reflect the sound back to the transducer.

There are two general categories of ultrasonic inspection -- through transmission and reflection. Through transmission requires access to both sides of a part. Reflection techniques are pulse-echo and pitch-catch. These testing techniques usually are both one-sided and depend upon the reflection of incident ultrasonic energy from an interface in a part. If the reflection is received by the transmitting transducer, the inspection is termed "pulse-echo," while if a separate transducer is used, the term "pitch-catch" is pertinent. In the latter case, the transducer spacing is variable.

General-purpose ultrasonic test units comprise the essential modules listed below.

1. A pulsed oscillator, which, when electronically triggered, generates a burst of alternating voltage. The principal frequency of the burst, its duration, the profile of the envelope of the burst, and the burst repetition rate may be either fixed or adjustable depending upon the flexibility of the unit.
2. A sending transducer to which the voltage burst is applied, and which mechanically vibrates in more or less faithful compliance with the applied alternating voltage. When appropriately coupled to an elastic medium, the transducer thus serves to launch ultrasonic waves into the medium.

3. A receiving transducer, which serves to convert ultrasonic waves that impinge upon it into a corresponding alternating voltage. In the "pitch-catch" mode, the sending and receiving transducers are separate units; in the "pulse-echo" mode, a single transducer alternately serves both functions.
4. A receiver that amplifies and (if desired) demodulates the received signal.
5. A display oscilloscope with which the user can observe the wave-form of signal voltages at various points in the system.
6. An electronic clock or timer which serves as a source of logic pulses and reference voltage wave forms. The timer governs the internal operation of the system as a whole.

The unit will also include a power supply. Additional features, which are often included in test units, are electronic compensation for loss of signal amplitude caused by attenuation of the ultrasonic pulse in the medium under test; and electronic gates, which monitor the return signal for pulses of a selected amplitude, and which occur within a selected time delay range (corresponding to flaws of a certain size at a prescribed depth range). Other refinements are available, especially in the areas of signal processing and automatic interpretation, and in the interfacing of the unit with mechanical scanning systems.

Ultrasonic testing is now a primary means of nondestructive evaluation (NDE). Of the big five NDE methods, only ultrasonics and radiography can reveal flaws which are substantially subsurface; the other (penetrant testing, magnetic-particle testing, and eddy-current testing) are restricted to the detection of surface, or slightly subsurface flaws. Because the propagation of ultrasound is essentially a mechanical phenomenon, it is especially suited to determining characteristics of engineering materials. The major NDE applications of ultrasonics include flaw detection, thickness measurement, and characterization of metallurgical structure. The principal advantages of ultrasonics are:

1. Its ability to penetrate to substantial depths in many important materials.

2. Its ability to test from one surface only.
3. Its sensitivity in the detection of minute flaws.
4. Its comparative accuracy in determining flaw size and depth.
5. Its electronic operation which enables rapid and substantially automated inspection.

The chief disadvantages are:

1. Its manual use requires technicians of considerable native ability, training, experience, and motivation.
2. It is intrinsically a small-area-coverage method -- large area coverage requires complex mechanical scanning or the use of numerous transducers in an array.
3. Its use, in general, requires a good, essentially direct mechanical coupling to the article to be tested, a requirement which is often difficult to meet in practice.

Ultrasonic test instruments require a specially trained and experienced operator if varied and unique inspections are to be made. Experience is especially important in distinguishing acceptable test signals from unacceptable signals. If the inspection to be performed is very repetitive, and the controls setup and acceptable signal patterns are tried and proven, the operation of the instrument may be turned over to a lesser skilled person.

Item Name: Sonoray Ultrasonic Flaw/Thickness Tester

Manufacturer: Branson Instruments Company  
Stamford, Connecticut 06904

Part/Model No.: 303

Figure No.: 18

Size: 14 in. x 9.5 in. x 5 in.

Weight: 12 lb

Power Requirements: 5 watts, supplied by NICAD rechargeable batteries, or 115V 50/60 Hz through recharging unit.

Cost: Approximately \$2700.00

Current Users: U.S. Navy  
Commercial companies

FSN: None

MIL Spec: Unknown

Operating Environment: Permissible ambient temperature range is  $-10^{\circ}\text{F}$  to  $150^{\circ}\text{F}$ .

Method of Operation: The model 303 tester is typical of most general-purpose ultrasonic test units. It is comprised of a basic unit containing all controls plus a cathode ray tube for display of test signals, and transducers which plug into the basic unit via coaxial cable. The model 303 can be set up to operate in either the pulse-echo mode in which a single transducer is used, or in the through transmission mode which requires two transducers. Contact or immersion testing is possible. When conducting contact tests, all air between the transducer(s) and the test article must be eliminated. This is accomplished by using a coupling medium, usually water, oil, or other prepared paste. Transmission may be via straight beam, angle beam, or surface wave. Test signals are displayed on the CRT which incorporates an internal graticule. An available optional feature is one which presents a digital thickness measurement or for obtaining the exact depth to a flaw indication. Controls on the front face of the basic unit include frequency selector, gain control switches, pulse delay control, test range selector and damping/gain controls. Pulse rates are automatically adjusted when manual adjustment of the frequency range is made.

Capabilities/Limitations: The model 303 has a frequency range of 1.0 MHz to 15.0 MHz. Selections are 1, 2.25, 5, 10, and 15 MHz. Penetration range is 0.1 inch to 250 inches in steel. Sensitivity is such that a 0.050-inch-diameter defect can be detected in steel, or thickness differences of 0.020 inch in steel can be measured. Batteries provide 10 to 12 hours of continuous service. Battery condition (charge) is monitored and displayed on face of basic unit. Recharge requires 14 hours.

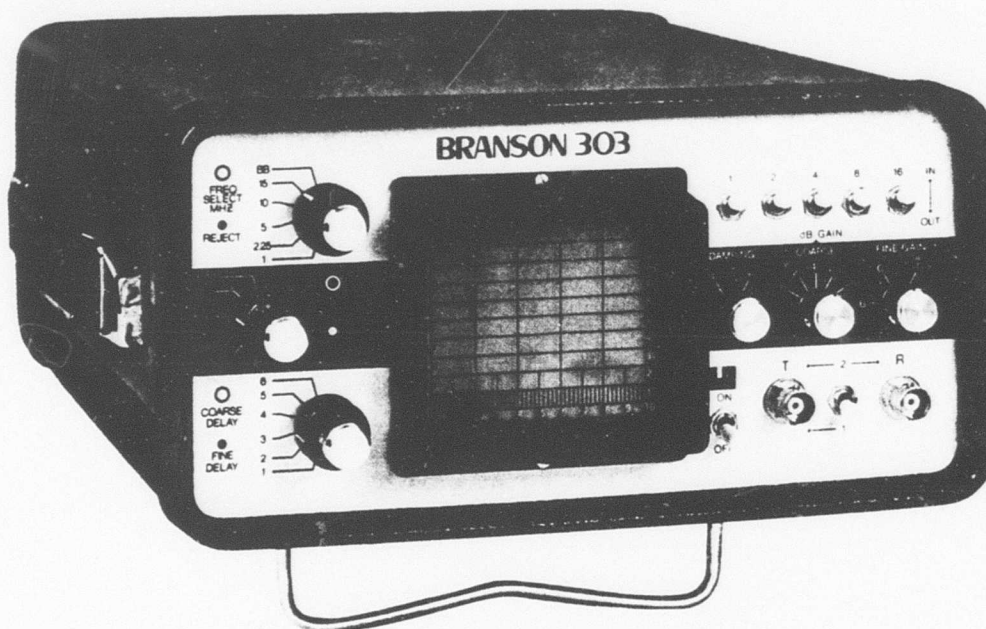

Figure 18. Sonoray Ultrasonic Flaw/Thickness Tester.

Item Name: Ultrasonic Flaw Detector

Manufacturer: Krautkramer Ultrasonics, Incorporated  
Stamford, Connecticut 06904

Part/Model No.: USM2

Figure No.: 19

Size: 10 in. x 5.5 in. x 14 in.

Weight: 12.8 lb (including battery pack)

Power Requirements: 110-240 volts AC or plug-in battery pack with NICAD dry cells.

Cost: Approximately \$2700.00

Current Users: Commercial companies including:  
Pratt & Whitney Aircraft

FSN: None

MIL Spec: Unknown

Operating Environment: Permissible ambient temperature is 5°F to 104°F.

Method of Operation: The USM2 Flaw Detector is capable of both generally used methods of ultrasonic inspection: the pulse reflection method and the through transmission method. The pulse reflection technique is most commonly used for crack detection because only one transducer, simultaneously operating as transmitter and receiver, is required. Coupling paste (water, oil or other preparations) must be used to eliminate air between the probe and the specimen. Test signals are displayed on a cathode ray tube (CRT), and automatic screen monitoring may be used. The CRT screen section to be monitored is selected by means of two controls which define the monitor "gate" in terms of width and position related to the expected flaw indications. If one of the flaw signals exceeds 1/5 of the CRT screen height, the monitor responds by sounding a buzzer or illuminating a signal lamp (worn as a ring on the operator's finger). The USM2 incorporates a selector switch which when set in first position permits testing for high resolution, that is, with narrower echo indications, but with less transmitter power. In the second position, testing is with high sensitivity, that is, with high transmission power, sacrificing some resolution. Other controls include calibrated gain control (used for exact flaw size determination), a test range selector (maximum of 5 meters), and a pulse delay control (to expand a particularly interesting section of material being displayed on CRT).

Capabilities/Limitations: The USM2 has a frequency range of 0.5 to 12 MHz by wide band amplifier. Its test range is continuously variable from 10 mm to 5 meters (in steel). Effectiveness is such that a defect 0.040 inch in diameter may be detected to a depth of 3 ft in steel. It may be used as a bench top instrument, or, when equipped with a battery pack and carrying vest, become an easily portable unit. Batteries provide 8 hours of continuous operation. State of charge of batteries is displayed under CRT. Recharge time is 14 hours for completely run-down batteries.

Skill/Training: Use of the USM2 Ultrasonic Flaw Detector for varied and unique inspections (not repetitive) requires an experienced operator who has had specialized training. The manufacturer offers a 1-week course of instruction designed to make

a person having no previous NDI experience proficient in operation of the USM2.

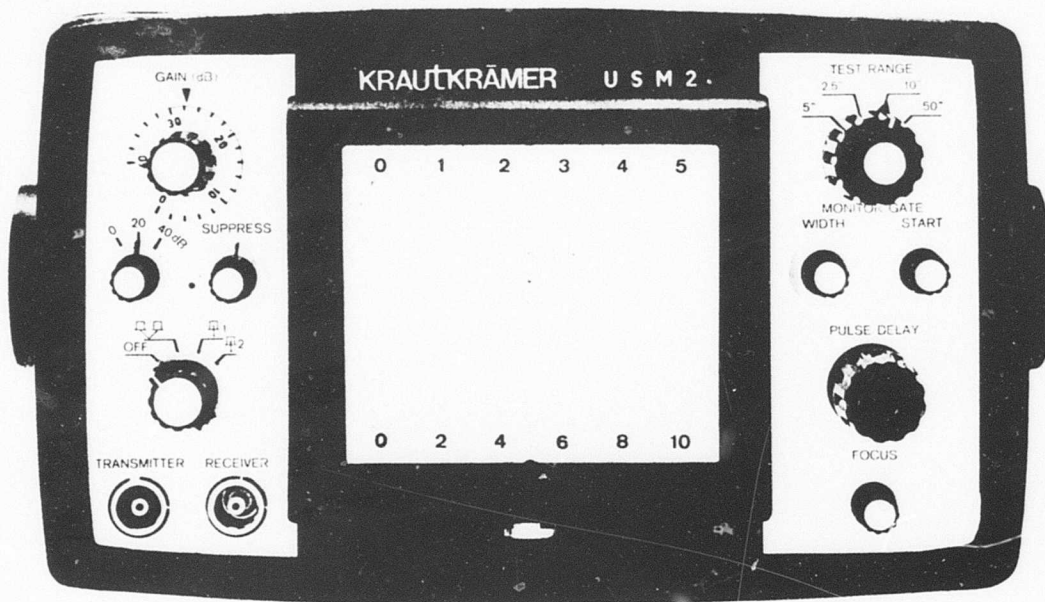

Figure 19. USM2 Ultrasonic Flaw Detector.

Item Name: Ultrasonic Vest-Pack Reflectoscope

Manufacturer: Sperry Division  
Automation Industries  
Danbury, Connecticut 06810

Part/Model No.: UVP

Figure No.: 20

Size: Front Pack - 4.5 in. x 11.25 in. x 11.75 in.  
Back Pack - 2.0 in. x 11.25 in. x 11.75 in.

Weight: Front - 5.5 lb  
Back - 8.5 lb

Power Requirements: Self-contained battery. Charging power requirements are 115 volt AC, 50/60 cycles, single phase, 10 watts.

Cost: Approximately \$650.00

Current Users: Commercial companies

FSN: None

MIL Spec: Unknown

Operating Environment: Permissible ambient temperature is 0°F to 160°F.

Method of Operation: The battery-operated UVP Reflectoscope was designed specifically to be worn by an operator and not restrict his mobility. A set of shoulder straps and elastic waist band allow even distribution of the weight of the front display pack and the rear battery pack. The viewing screen is situated an ideal 18-20 inches from the operator's eyes. The unit is capable of operation in the pulse-echo mode with single and dual search units or in the through-transmission mode. Controls are relatively simple and include sensitivity (attenuation) control, sweep delay, and frequency control. A transigate/audible signal and a distance amplitude correction device are available as optional equipment.

Capabilities/Limitations: The UVP Reflectoscope has a frequency range 1.0 MHz to 10 MHz via a broadband amplifier. The sweep display range is 0.5 inch to 20 inches for steel. Sensitivity (attenuation) control is calibrated to 69 dB and has a digitized display. The unit may be used as a bench top instrument by locking the front and back packages together as one unit. Batteries provide 8 hours of continuous operation. A battery charge level indicator is provided. Recharge time is 16 hours.

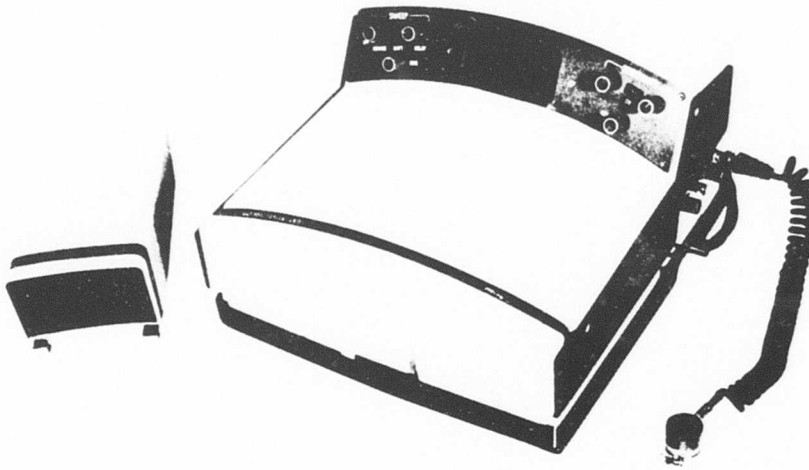

Figure 20. Vest-Pack Ultrasonic Flaw Detector.

Item Name: Ultrasonic Reflectoscope

Manufacturer: Sperry Division  
Automation Industries  
Danbury, Connecticut 06810

Part/Model No.: UJ

Figure No.: 21

Size: 4.625 in. x 9 in. x 12.5 in.

Weight: 12 lb (with  
AC)  
14.5 lb (with  
battery)

Power Requirements: 115 volts AC, 50/60 Hz, or 10 volts DC  
battery pack consisting of five lead dioxide "X" cells.

Cost: Approximately \$2300.00

Current Users: Commercial companies

FSN: None

MIL Specs: Unknown

Operating Environment: Permissible ambient temperature is 0°F  
to 150°F.

Method of Operation: The model UJ Reflectoscope may be used in the pulse-echo mode or in the through-transmission mode. Either contact or immersion tests may be performed. Transmission may be via straight beam, angle beam, or surface wave. The basic instrument provides a CRT display of defects or dimensional variations. Instrument controls include test frequency control, sweep delay, sweep length, and calibrated gain control. Optional plug-in circuit modules can provide additional functions such as gating and alarm operation, sweep markers, distance-amplitude compensation, and digital readout of material thickness.

Capabilities/Limitations: The UJ Reflectoscope has a frequency range of 0.4 to 10 MHz. Its test range is from 0.5 inch to 400 inches in steel. The instrument is small and light enough to be suitable for field inspection work. It may also be used as a bench top instrument in the shop or laboratory. A rack mounted version is available for system installations. Batteries provide 8 hours of continuous operation, and a battery state of charge indicator is located on the front panel. Battery recharge time is approximately 12 hours.

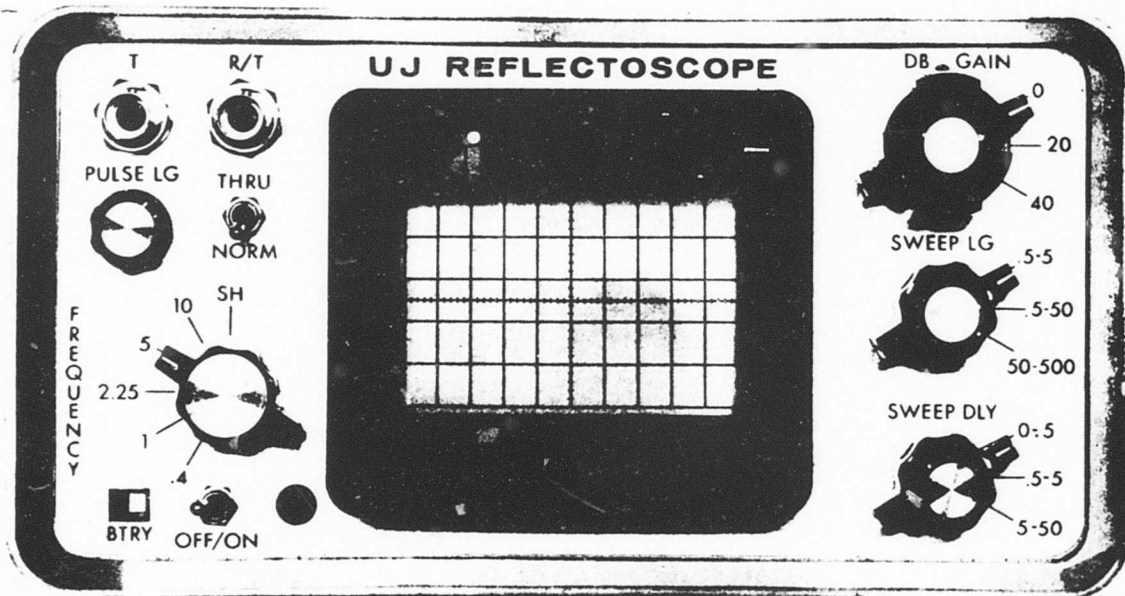

Figure 21. Ultrasonic Reflectoscope.

## X-Ray Inspection

X-radiation is produced when some form of matter is struck by a rapidly moving, negatively charged electron. Three basic requirements must be met to produce this condition:

1. A source of electrons
2. A means of directing and accelerating electrons
3. A target for the electrons to bombard

If a suitable material is heated sufficiently, some of the electrons in the material will become so thermally agitated that they will boil off, escape from the material, and surround it in the form of a cloud. This cloud of electrons will hover about or return to the emitting material (cathode) unless some external force pulls it away. The fundamental law of electrostatics states that like charges repel each other and unlike charges attract each other. Thus, a strong unlike or positive charge (on an anode) is used to produce an attracting force to move the electrons from the cathode to the anode, creating a flow of charge, or current, between them. It is important that this movement be conducted in a good vacuum; otherwise, the electrons would collide with gas molecules, causing ionization and loss of energy.

To create X-rays, it is necessary that the electrons strike some substance. In the X-ray tube, a solid material is used for the target. The higher the atomic number of the target material, the higher the efficiency of X-ray production. Unfortunately, only a small percentage of the kinetic energy available in the electron beam is converted into X-radiation; the remaining energy is converted into heat that must be dissipated by the target material.

The intensity of  $\lambda$ -rays produced in an X-ray tube by the collision of the electrons with the target is directly proportional to the tube current and is, in general, a function of the cathode-to-anode voltage raised to a power greater than 2.5.

In the inspection process, penetrating radiation emitted by the X-ray generator is imposed on a test object. The object transmits or attenuates the radiation as a function of its physical characteristics, i.e., variations in cross section, density, etc. Cracks, voids, inclusions and other flaws in the object's internal structure are revealed and recorded on radiographic

film placed on the side of the test object opposite the side where the radiation source is located.

X-ray beam quality is usually expressed in terms of the thickness of some reference attenuator material (e.g., aluminum, copper, or iron) required to reduce the intensity of the beam to one-half of its original value.

An X-ray film is basically a sheet of transparent, blue-tinted, cellulose derivative material, coated on either one or both sides with a photosensitive emulsion. The emulsion consists of gelatin in which is dispersed very fine grains of silver halide salts, primarily silver bromide. The emulsion is about 0.001 in. thick on either side of the film. When the silver halide grains are exposed to radiation, they become sensitized. When they are subsequently treated with a chemical solution (developer), a reaction takes place causing the reduction of the silver salts to black, metallic silver. This silver, suspended in the gelatin, constitutes the image. The film is left in a developer solution long enough to allow the sensitized grains to be darkened, that is, reduced to metallic silver. After the film has been developed, it is placed in a weak acid solution to stop the action of the developing solution. The film is then placed in a fixing bath, commonly called "hypo," which dissolves all the undeveloped salts and leaves only the metallic silver or dark grains in the emulsion. The hypo also contains agents that harden the emulsion to make it more durable. Finally, the film is thoroughly rinsed in running water to remove all traces of the various solutions, and then dried. When the processed film is viewed in front of a strong light, those areas of the film that were not exposed to light or X-rays are relatively transparent, while those areas exposed to X-rays contain metallic silver and are dark or opaque.

The complexities of X-ray techniques essential for crack detection dictate that a highly trained and experienced operator be employed. Setup of the basic unit, x-ray tube, and film is critical if proper contrast, resolution and density of exposure are to be achieved. Cracks which are not parallel to the X-ray beam are more difficult to detect than those that are, and the operator will need to be resourceful in his setups and skilled in interpreting the exposed film. Once a setup for a repetitive application has been tried and proven, and confid-

ence in results established, the operator's job may be turned over to a lesser skilled person. All operators, skilled or unskilled, must be thoroughly familiar with the safety hazards posed by the equipment and constantly guard against them.

Item Name: Flexitron Portable X-Ray Unit

Manufacturer: Hewlett Packard  
Lexington, Massachusetts 02173

Part/Model No.: 846 Figure No.: 22

Size: 7.5 in. x 20 in. x 9.75 in. Weight: 55 lb

Power Requirements: 110 volts AC, 60 Hz, 1100 watts or 240 volts, 50 Hz or battery/inverter pack.

Cost: Approximately \$4000.00

Current Users: U.S. Navy  
U.S. Department of Transportation  
Law Enforcement Agencies  
Commercial companies

FSN: None MIL Spec.: MIL-STD-453

Operating Environment: 20<sup>o</sup>F to 110<sup>o</sup>F

Method of Operation: A 110-volt AC, 60-Hz power source is connected to the unit. The cord of a remotely operated exposure switch is plugged into the unit. Voltage selector switch is set at 100 KV or 150 KV depending on penetration and contrast required. The unit's pulser is pressurized via an integral hand-operated air pump. Exposure selector is adjusted to select the number of pulses to be used. The X-ray unit is placed in front of the object to be inspected, and film is placed behind the object. Lastly, the remotely operated exposure switch is depressed. When the configuration or location of the test object dictates, the internal X-ray tube may easily be removed, mounted, and operated remotely from the basic unit. Optional equipment includes a beam limiter to adjust rectangular beam area to various conventional film sizes up to 14 inches by 17 inches. A film cassette allows use of 4-inch by 5-inch Polaroid films. A cart and tube stand provides improved mobility

for the basic unit, and support for a remotely mounted X-ray tube. A flashlight size 150 KV "mini" X-ray tube is available for special applications that require small size.

Capabilities/Limitations: The model 846 is a portable, single package X-ray system with integral X-ray tube. The tube may be removed, however, and operated remotely up to 100 feet from the pulse generator in hard to reach or hazardous areas. The inherent filtration of the unit exceeds 2.5 mm aluminum. Pulse duration is 0.05 microsecond. Pulse rate is 25 per second at 100 KV and 14 per second at 150 KV. Access to both sides of test object is required. Density and thickness representations may vary up to 2 percent of actual. X-ray is best suited for evaluating corrosion, porosity, shrink, inclusions, etc. It is not completely reliable in detecting cracks. Its effectiveness in this regard is a function of the operator's skill and experience. Use of Polaroid films reveals results of inspection in only 10 seconds. The X-ray tube is warranted at 10,000 pulses, and the manufacturer reports 30,000 to 100,000 pulse lives are not uncommon. The number of pulses generated for a single radiograph may be from 1 to 99. As with all X-ray equipment, the model 846 inherently poses a radiation problem for operating personnel, and great care must be exercised in its use.

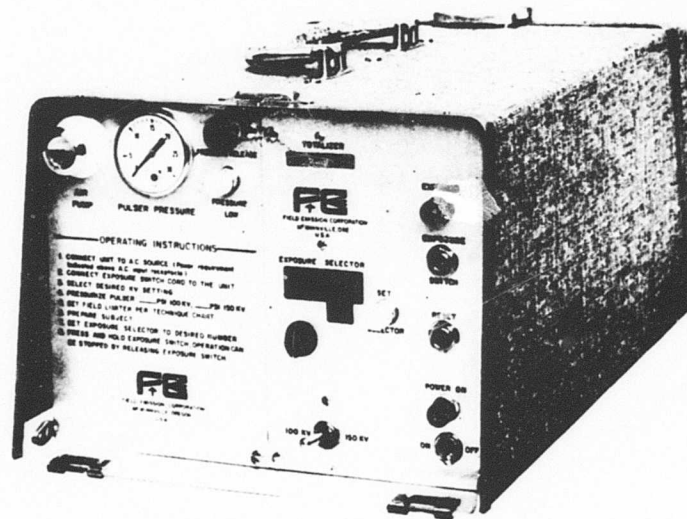

Figure 22. Flexitron Portable X-Ray Unit.

Item Name: Portable X-Ray System

Manufacturer: Sperry Division  
Automation Industries  
Danbury, Connecticut 06810

Part/Model No.: SPX 120 KV Figure No.: 23

Size: X-Ray Head - 6 in. dia. x 18 in.  
Control Unit - 2 in. x 3 in. x 7 in.  
Power Pack - 8 in. x 9 in. x 12 in.

Weight: X-ray Head - 24 lb  
Control Unit - 1.75 lb  
Power Pack - 36 lb

Power Requirements: Rechargeable battery pack.

Cost: Approximately \$4000.00

Current Users: Military field hospitals  
Commercial manufacturing companies  
Veterinarians

FSN: 6525-930-3275 MIL Spec: Unknown

Operating Environment: Operates at temperatures from -30°F to +130°F.

Method of Operation: The SPX 120 KV is a compact, portable, battery-operated X-ray system having three major components: the X-ray head, the control unit and the power unit (battery). A 25 foot cable is provided for remote operation of the control unit. Operating voltage is fixed at 120 KV. In operation, penetrating radiation emitted by the X-ray head is imposed on a test object. Radiation transmitted or attenuated by the test object exposes film forming an image displaying the physical characteristics of the test object. The film must be placed behind the test object, while the X-ray head is placed in front.



Figure 23. SPX 120KV Portable X-Ray System.

Capabilities/Limitations: Main beam filtration is 2 mm aluminum. Effective focal spot size is 1.5 mm by 1.5 mm. Emission cone angle is 40°. Current draw is adjustable to 2 ma. Exposure time is adjustable from 0.125 to 12 seconds. Design duty cycle is 10 percent (12 seconds on, 120 seconds off). Total exposure time without recharging batteries is approximately 1200 seconds. Battery recharge time is approximately 10 hours and recharges from 110/220 volts AC, 50/400 Hz, single phase source.

Item Name: Portable Air Cooled X-Ray Unit

Manufacturer: Sperry Division  
Automation Industries  
Danbury, Connecticut 06810

Part/Model No.: 160EA-8

Figure No.: 24

Size: X-Ray Head - 7 in. dia. x 31 in.  
Control Unit - 9 in. x 12 in. x 14 in.

Weight: X-Ray Head - 33 lb  
Control Unit - 30 lb

Power Requirements: 105-125 Volts AC, 50/60 cycle, single phase

Cost: Approximately \$6300.00

Current Users: Commercial manufacturing companies  
U.S. military

FSN: 6635-018-5835

MIL Spec: Unknown

Operating Environment: Operates at temperatures from -30°F to +130°F.

Method of Operation: All operations of the X-ray tube head are handled from the top panel of the control unit. A green light indicates when power switch is on and a red light when the X-ray switch is activated. Kv and Ma can be preset, but can also be controlled continuously and are indicated on 3-inch meters. A 30-minute timer is provided. It automatically terminates the X-ray exposure at the preset time, but the X-ray "off"

button stops the exposure at any time. An interlock on the panel provides for external connection of warning lights or alarms. The X-ray tube emits a beam from its side at a point about 6 inches from the anode end. Cooling is accomplished by an integral fan pulling air over a finned aluminum radiator. A gage at the bottom indicates internal pressure of the insulating gas in the head. A thermal switch on the anode end prevents operation of the tube head if it should overheat.

Capabilities/Limitations: The duty cycle of the 160EA-8 is continuous (100 percent) with no external cooling required. Its sensitivity is such that a 0.010-inch hole in a 0.010-inch-thick aluminum penetrometer, placed on a 1.0-inch test block, can be detected at a source-to-film distance of 36 inches. Radiation output is 7.6 r/min. through 0.5-inch aluminum at 50 cm distance. Radiation quality is such that half value layer is 0.4-inch aluminum after passing through 0.5-inch aluminum. Inherent filtration is 2.3 mm of beryllium (capable of showing density difference of 2.5 H&D units between aluminum foil 0.003 inch thick and 0.030 inch thick). Range of voltage applied to X-ray tube is 35 KV to 160 KV. Range of current flowing through X-ray tube is 2 Ma to 5 Ma. Both ranges are adjustable and displayed on meters. An external AC power source (single phase) is required. The unit is stabilized against line load fluctuations from 105V to 125V. Source may be either 50 or 60 cycles; however, if 50 cycles is used, then time correction must be made because timer is a 60-cycle unit.



Figure 24. SPX 160 KV Portable Air Cooled X-Ray Unit.

Item Name: Portable X-Ray Unit

Manufacturer: Balteau Electric Corporation  
Stamford, Connecticut 06902

Part/Model No.: 140B

Figure No.: 25

Size: X-Ray Head - 7 in. x 9.5 in. x 13.5 in.  
Frame - 8.375 in. x 12 in.  
Control Unit - 12 in. x 10 in. x 6.5 in.

Weight: X-Ray Head and Frame 53 lb  
Control Unit - 29 lb

Power Requirements: 115 volts (230 volts on request), 50 or 60 cycles single phase, 1200 volt amperes, 800 watts.

Cost: Approximately \$4700.00

Current Users: U.S. Navy  
U.S. airlines  
Commercial manufacturing companies

FSN: Unknown

MIL Spec: Unknown

Operating Environment: Waterproof and dust proof for all weather field use.

Method of Operation: The control unit is connected to a 110-volt AC, 60-Hz power source. A 30-foot-long control cable is used to connect the control unit with the X-ray head. The voltage control is adjusted (max. 140 KV) to produce the desired depth of penetration and contrast. The Ma rating is automatically kept at maximum value for all KV settings. The control unit also contains a line compensator and a push button powered automatic reset timer for controlling exposure time.

Capabilities/Limitations: The 140B is a portable, waterproof, dust-proof X-ray system for all weather field use. Its penetration capabilities are 1.75 inches through steel with tungstate screen, and 0.875 inch through steel with lead screen. Inherent filtration is low. This characteristic, combine with low attainable kilovoltages, enables thin magnesium or plastics to be radiographed with good results. An external AC power source, single phase, 50-60 cycles is required.

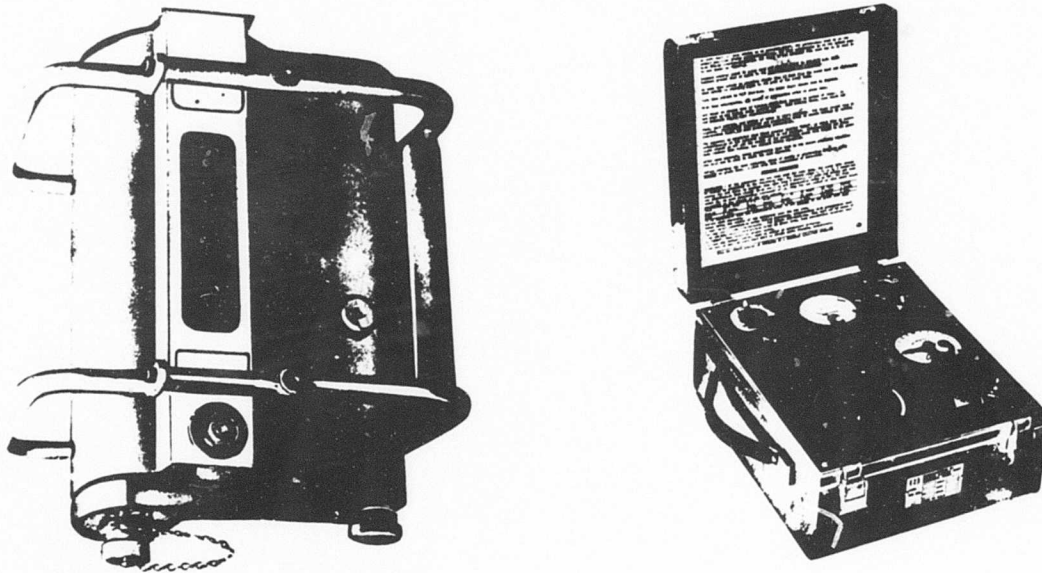

Figure 25. Baltospot Portable X-Ray Unit.

## WEAR - ROD END BEARINGS

Wear manifests itself in different ways on different components, often showing more than one excessive wear symptom. For example, on skid shoes, it is reduced metal thickness on the shoe -- a possible application for an ultrasonic metal thickness detector. On spherical rod end bearings, it is excessive radial or axial play, a condition detectable by relative movement indicators. Rod end bearing wear is often measured by mechanic "feel" while the rod end is installed in the helicopter. The measurement problem is to detect when allowable wear is on the order of 0.020 inch to 0.030 inch. The present method of measurement is by "feel" or "shake" while the rod end is installed in the helicopter, which is exceedingly inaccurate, or by dial indicator measurement after the rod end is removed from the helicopter, which is difficult and time consuming.

Numerous push-pull rods, cranks, levers, arms, etc., are used in helicopters for flight control and other key linkages. Inspection checklists specify a check of excessive looseness for spherical ball rod end bearings. Many times, it is impossible to use a dial indicator due to restricted space and access problems. Maintenance history records indicate that these items are rejected as being worn or chafed 20 percent to 57 percent of the time and improperly adjusted 18 percent to 35 percent of the time. Rod end bearing wear measurements are made on all helicopters. The ideal rod end bearing measurement device or method must have a range of 0.001 to 0.040 inch with an accuracy of  $\pm 0.001$  inch. The device or instrument should also ideally provide a direct readout of axial and radial play for rod end bearings located in limited access areas.

A typical application of the required instrument can be explained from a CH-47 requirement. The CH-47 utilizes a number of connecting links on its flight control mixing linkage. In this case, a corrosion-resistant steel tube is used to which rod ends with dry-type bearings are secured via a turnbuckle. The links transfer control motions to and from the control mixing assembly. Access is via the closet controls access panels. Inspection in this application has the following restrictions. Axial play between rod ends and the bell crank lug should be less than 0.010 inch. Radial play on antifriction bearings should be less than 0.004 inch. Radial play on dry-type bearings should be less than 0.007 inch.

Investigation of wear measurement devices has included an ultrasonic metal thickness detector for skid shoe wear and a built-in measuring pin, linear motion sensor and optical comparator for rod end bearing wear.

The devices and techniques under investigation are all non-subjective indicators of excessive bearing wear. However, the techniques require some degree of developmental work. Figures 26 and 27 illustrate rod end bearing usage. Rod end bearings are used extensively and the resultant maintenance and inspection is time consuming. Any attempt to alleviate the subjectivity of the inspection and the maintenance time will be a decided improvement.

Item Name: Bearing Wear Pin

Manufacturer: None at Present

Part Number: None at Present

Figure No.: 28

Size: 3/8 in. l. by 1/4 in. dia.

Weight: Negligible

Power Requirements: None

Cost: Development costs estimated high.  
Per unit costs low.

Current Users: Not developed yet

FSN: None at Present

MIL Spec: None at Present

Operating Environment: Temperature limited to that of bearing. Uses no electrical power. May be safely used in any environment.

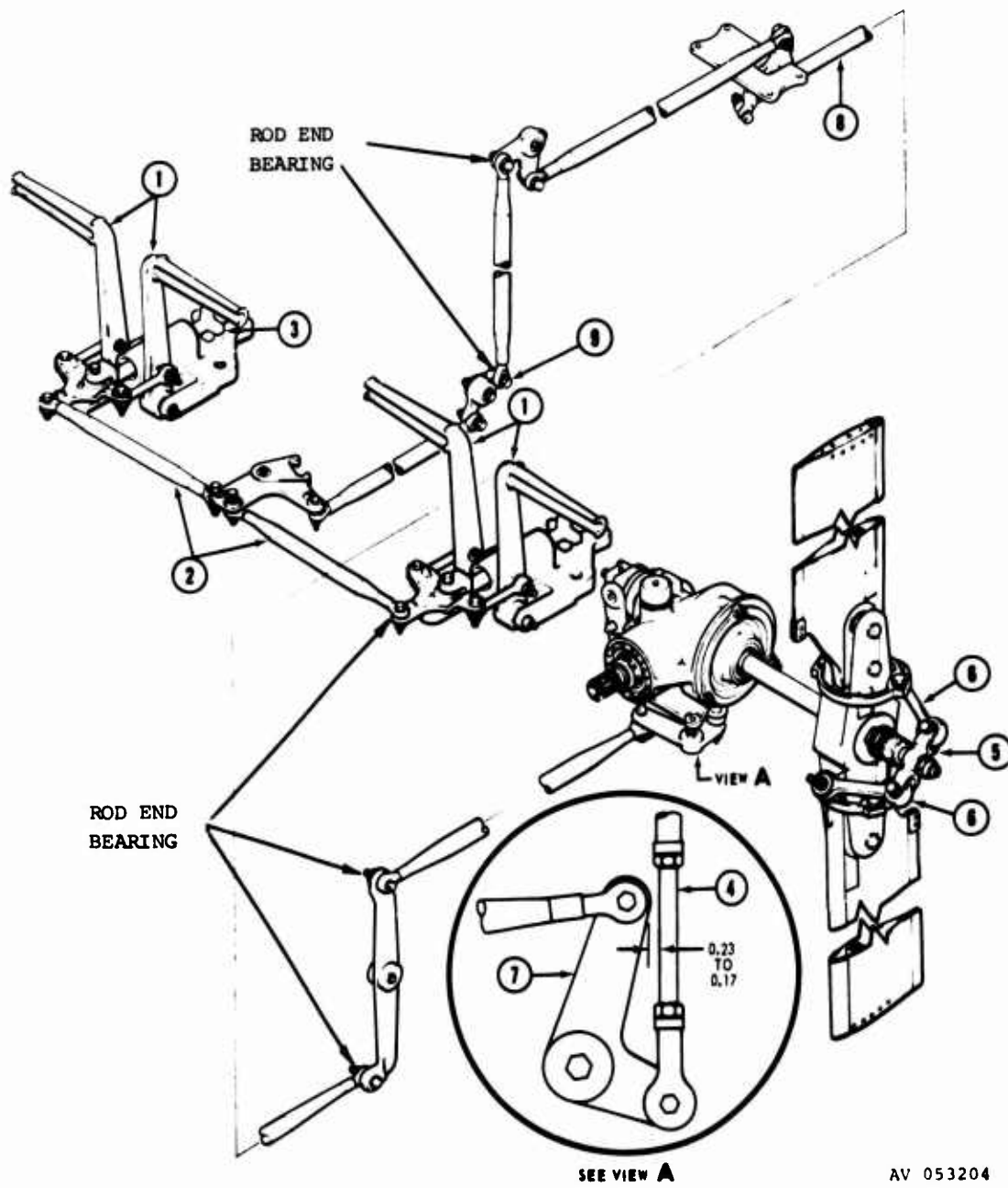

- |                   |                 |         |
|-------------------|-----------------|---------|
| 1. Pedal Assembly | 5. Crosshead    | 9. Bolt |
| 2. Control Tubes  | 6. Pitch Links  |         |
| 3. Adjuster Knob  | 7. Bellcrank    |         |
| 4. Rod Assembly   | 8. Control Tube |         |

Figure 26. OH-58 Tail Rotor Control System.

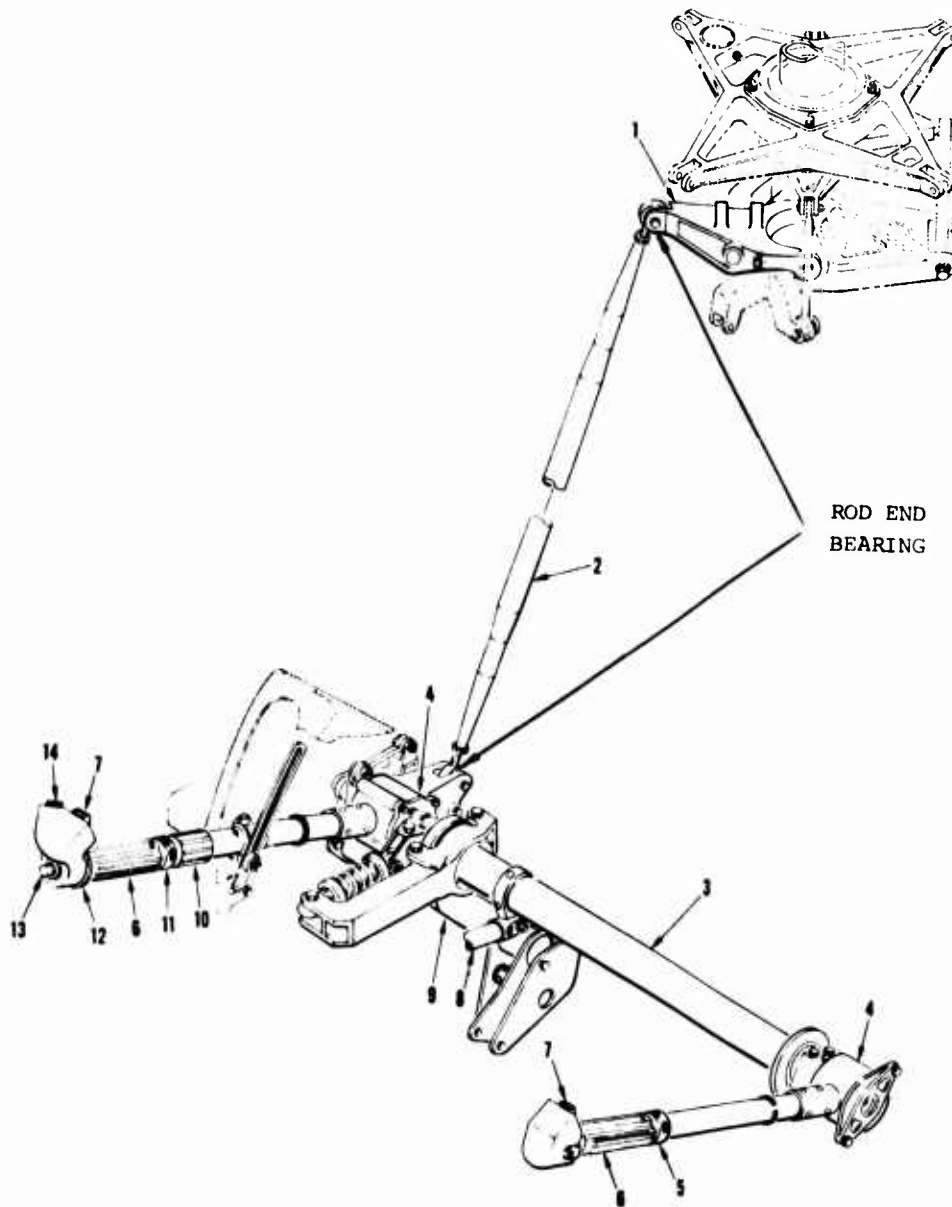

- |   |  |
|---|--|
| <ul style="list-style-type: none"> <li>1. Collective pitch mixer bellcrank</li> <li>2. Tunnel-routed collective mixer control rod</li> <li>3. Collective interconnecting torque tube</li> <li>4. Collective pitch stick housing</li> <li>5. Throttle friction (fixed)</li> <li>6. Throttle grip</li> <li>7. N2 governor switch</li> </ul> | <ul style="list-style-type: none"> <li>8. N2 governor (droop control) override link</li> <li>9. Control support bracket</li> <li>10. Stick friction</li> <li>11. Throttle friction (adjustable)</li> <li>12. Idle stop release ring</li> <li>13. Starter switch</li> <li>14. Landing light switch</li> </ul> |
|---|--|

Figure 27. OH-6 Collective Controls.

Method of Operation: The development of this device should be pursued with bearing manufacturers. It is by far the simplest and least subjective device researched. A pin is permanently trapped in the outer race of the rod end bearing. The pin is restricted from moving outward by a shoulder or tapered surface. The pin is restricted from moving inward by the spherical ball. The pin is free to move between these two limits. (The free motion is greater than the allowable wear.) When one end of the pin is in contact with the spherical ball, the other end protrudes above the outer surface of the rod end bearing. The long axis of the pin coincides with the long axis of the rod end bearing which is the axis of greatest wear.

At the time of manufacture the ball is loaded into intimate contact with its spherical seat on the side opposite the pin. The protruding portion of the pin is machined off until the pin height above the adjacent surface of the rod end bearing is

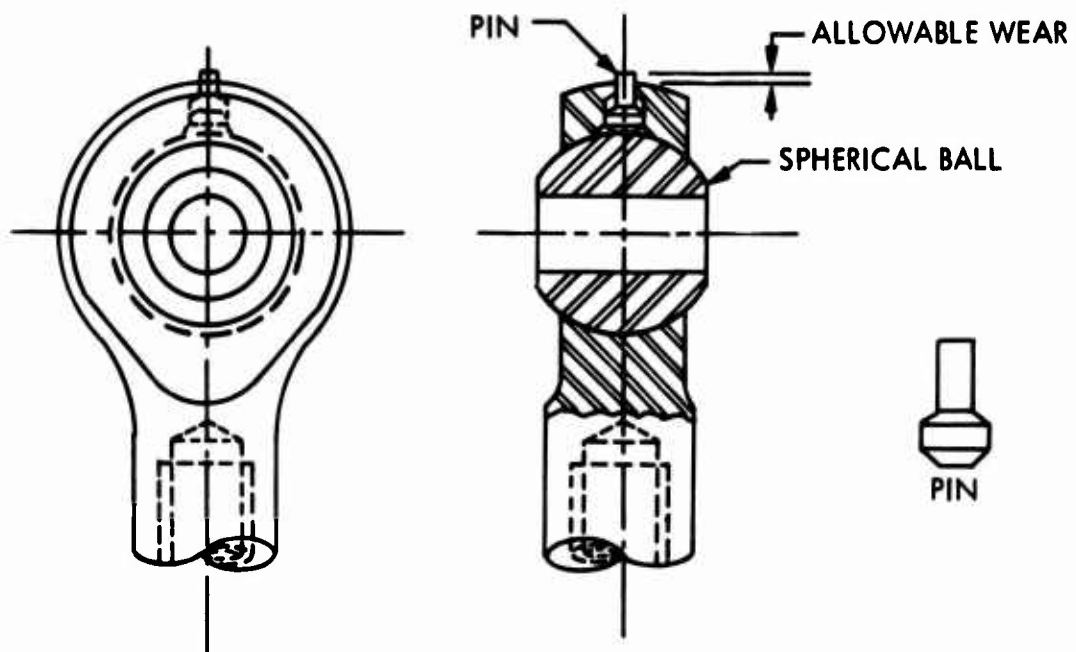

Figure 28. Rod End Bearing Wear Pin Installation.

equal to or slightly less than the allowable wear. As the rod end bearing wears (with the control linkage loaded in compression), the pin is depressed by a mechanic into contact with the spherical ball. Wear will gradually allow the pin to sink

below the adjacent surface of the rod end. When this event occurs, the rod end bearing must be replaced. The method of operation involves only the depression of the pin by the mechanic and the resultant go/no-go indication.

Capabilities/Limitations: The technique is applicable to the indication of radial bearing wear on all rod end bearings. It eliminates the subjectivity in the determination of excessive bearing wear. However, it will require a design effort to develop the concept, and it is applicable only to radial wear.

Skill/Training Requirements: The reading of the bearing wear pin is simple and straightforward. The pin is depressed by a finger while the linkage is loaded in compression. No interpretation of the indication is required. No specialized training is required.

Item Name: Linear Displacement Sensor

Manufacturer: Transducer: Bourns Inc  
Instrument Division  
Riverside, California 92506

System: To be determined.

Model Number: Transducer: 157-1K-.50

Size: Unknown Figures No.: 29, 30

Costs: Development costs low. Weight: Approx. 5 lb  
Per unit costs under \$200 (estimated)

Current Users: Not developed yet.

FSN: None at Present Mil Spec: None at Present

Operating Environment: Temperature limited to operator tolerance. Uses battery power. May be used in all helicopter environments.

Method of Operation: The development of this system should be pursued with potentiometer manufacturers. It is a relatively simple and nonsubjective device. The system consists of a linear transducer mounted in or onto a permanent magnet, clothes-pin clamps, and a meter with a dial calibrated to read displacement.

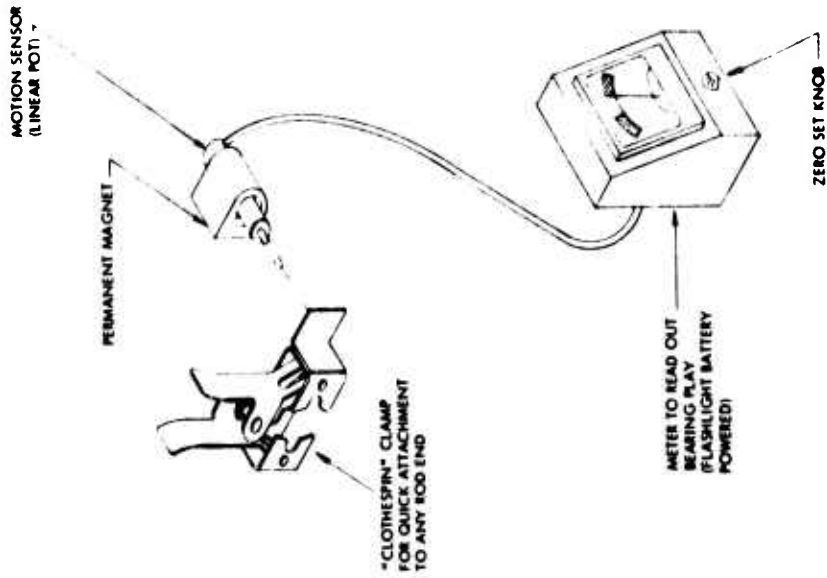

TO CHECK RADIAL PLAY IN ROD END BEARING:

1. PLACE SENSOR ON HEAD OF BEARING BOLT. PERMANENT MAGNET WILL SECURE IT IN PLACE.
2. CLIP THE "CLOTHESPIN" CLAMP ONTO THE BELLCRANK OR MEMBER FORMING THE OTHER SIDE OF THE JOINT, ASSURING THAT IT HAS SENSOR PLUNGER PARTLY DEPRESSED. PLUNGER HAS .50" AVAILABLE TRAVEL.
4. MANUALLY MOVE JOINT TO TAKE UP ALL PLAY IN ONE DIRECTION.
4. ZERO THE METER WITH KNOB.
5. MANUALLY SHAKE JOINT TO WORK BEARING THRU FULL PLAY.
6. READ OUT BEARING PLAY FROM METER.

Figure 29. Linear Displacement Sensor (Rod End Bearing Play).

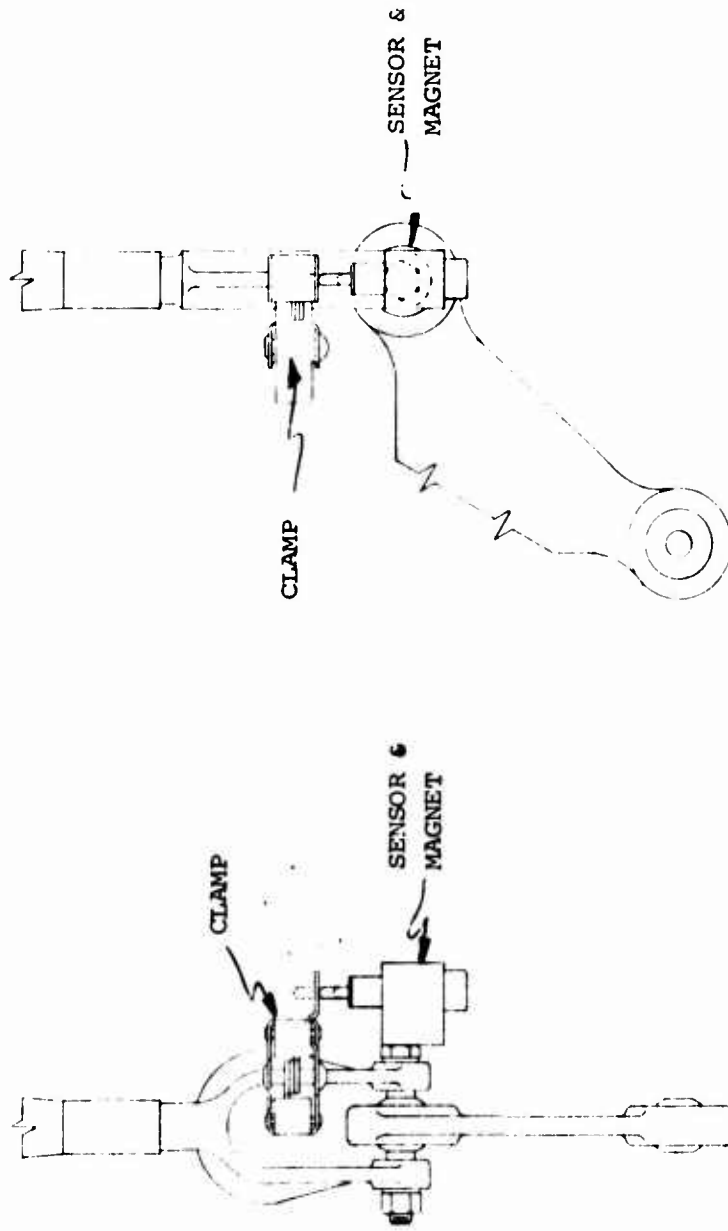

Figure 30. Rod End Bearing Play Sensor - Radial Direction.

The sensor and magnet are secured to the head of the bolt used in all rod end bearing applications (see Figure 30). The spring-loaded clothespin clamp is attached to the bell crank or member comprising the other part of the joint. This clamp is mounted so that the sensor shaft is partly depressed. The sensor is connected to the displacement meter.

The mechanic would load the control linkage under consideration in compression and then zero the meter with the knob on the meter case. He would then load the control linkage in tension and shake joint to work the bearing fully. The bearing play is then read out directly on the meter.

Capabilities/Limitations: The technique is applicable to the indication of bearing wear in all rod end bearings. It eliminates the subjectivity in the determination of excessive bearing wear. It should be used in areas where more inspection accuracy is required than with dial indicators. It should be simpler overall than the dial indicator. This technique will require a design effort to develop the concept. It does require the positioning of the devices on each rod end bearing to be inspected. This is apt to be time consuming and at times awkward. It will require different clamps for measuring radial and axial bearing play.

Skill/Training Requirements: The meter gives a direct readout and no interpretation is required. The adjustment of the meter following the loading of the linkages is simple. No specialized training is required.

Item Name: Fotonic Sensor

Manufacturer: Mechanical Technology, Incorporated  
Instruments Division  
Latham, New York 12110

Model No.: KD-38 (to be modified)

Size: 6 1/2 in. x 4 in. x 3 3/4 in.      Figure No.: 31

Cost: Development costs low      Weight: 2 lb 6 oz  
Per unit costs estimated at \$200

Power Requirements: 115 vac, 60 Hz, 6 watts

Current Users: Not developed yet.

FSN: None at Present

MIL Spec: None at Present

Operating Environment: The probe temperature range exceeds that of the operator's tolerance. The meter range (uncompensated) is 10°F to 150°F. Uses 115 vac power.

Method of Operation: The development of this sensor should be pursued with fiber optics manufacturers. It is a relatively simple and nonsubjective device. The system consists of a fiber optic probe mounted in or onto a permanent magnet, clothespin clamps, and a photo receiver. The sensor and magnet are secured to the head of the bolt used in all rod end bearing applications. The spring-loaded clothespin clamp is attached to the bell crank or control tube comprising the other part of the joint. This clamp is mounted so that a small gap (0.06 inch) exists between the sensor tip and the clamp flange. The sensor is connected to the photo receiver. Any movement causes variations in the amount of light transmitted through the fiber optic probe and reflected by the reference surface. This reflected light is conducted back through the probe to the photo receiver where a meter would indicate displacement.

The mechanic would load the control linkage under consideration in compression and zero the meter. He would then load the control linkage in tension and shake the joint to work the bearing fully. The bearing play is then read out directly on the meter.

The development aspects involve the redesign of the meter to give direct readout in inches, the modification of the circuitry for the zero-adjust feature, and the improvement of the compensated temperature range.

Capabilities/Limitations: The technique is applicable to the indication of bearing wear in all rod end bearings. It eliminates the subjectivity in the determination of excessive bearing wear. It should be used in areas where more inspection accuracy is required than with dial indicators. It should be simpler overall than the dial indicator system. This technique will require a design effort to fully develop the system. It does require the positioning of the sensors on each rod end bearing to be inspected. This is apt to be time consuming and

at times awkward. It will require different clamps for measuring radial and axial bearing play.

The present photo receiver requires 115 vac power. The design effort should endeavor to make it a battery-powered system.



Figure 31. Fotonic Sensor-Optical Proximity Detector.

Skill/Training Requirements: The designed meter should give a direct readout of displacement so that no interpretation is required. The adjustment (zeroing) of the meter following the loading of the linkages should be simple. No specialized training is required.

#### BEARING WEAR

Inspection for excessive wear in major load-carrying ball and roller bearings is usually accomplished by routinely checking for looseness, roughness and noise occurring during operation or manual rotation of the bearing. When any of these symptoms are found, the procedure usually requires a complete disassembly of the bearing for further examination. The method of inspection

is highly subjective and may result in bad bearings being allowed to remain in service while good bearings are needlessly replaced.

Excessive bearing wear or internal failure is invariably accompanied by changes in temperature, noise and/or vibration. If these parameters can be measured accurately and compared in some quantitative manner to those of a good bearing, it is possible to reduce the subjectivity involved in detecting bearing degradation and impending failure. Of the three parameters, temperature sensing has been used most successfully, although there are problems associated with selecting the proper location(s) for temperature pickup and compensating for variations in bearing operating temperatures. Techniques for using noise and vibration as indicators of bearing condition are in the early stages of development and have not yet been widely employed. Both of these parameters are influenced by many factors such as bearing size, number of rolling elements, operating speed, etc. The problem is further complicated by difference in materials, manufacturing tolerances, parts stackups, etc. The failure mode (spalling, Brinelling, cage breakup, etc.) also significantly affects the noise and vibration levels produced.

#### Ultrasonic Translator Detectors

A fluid leak through an orifice produces sonic energy as a result of the transition from laminar to turbulent flow. It has been shown that leaks of this type produce energy in the 30 to 50 khz region although the distribution varies with the leak rate and pressure. Ultrasonic translators use this ultrasonic noise to detect and localize the source of the leak. To isolate the ultrasonic frequencies characteristic of such leaks, the translator uses a band pass filter to remove all sounds below 15,000 hertz, the audio frequency range. An oscillator is used to heterodyne the ultrasonic band, typically 35 to 45 kHz. Through filtering, the ultrasonic frequencies are converted to a group of frequencies between 100 and 4000 hertz, within the range of peak hearing. The relative characteristics are retained to permit analysis of the amplitude and characteristics of the received ultrasonic signals.

Ultrasonic translators are effective for orifice leak detection in both low pressure and high pressure fluid systems. Detection of leaks has been accomplished at distances up to and

beyond 100 feet. Diffused or labyrinth-type leaks do not possess the required turbulence and thus are not detectable ultrasonically. For the leak detection application, the ultrasonic translator is equipped with a general-purpose probe which focuses on ultrasonic energy in the atmosphere. Earphones are generally used, especially in areas where audible hissing sounds are present which could be confused with the instrument output.

Ultrasonic translators can also be used to detect ultrasonic energy generated within metallic structures. The airborne probe is useable in such applications only if the metallic surface is light enough to be oscillated mechanically by the acoustic energy. Thin-wall tubing or sheet metal structures are typical examples. Heavier metallic structures such as cast fluid power components and bearing housings readily conduct ultrasonic energy, but the mass of the structure prohibits sufficient reverberation to transmit the energy through the atmosphere. It is necessary, therefore, to sense the ultrasonic transmissions through direct contact with the structure. A contact-type probe has been developed for this purpose.

The probe stylus responds to infinitesimal mechanical vibration conducted from the ultrasonic source through the structure. This energy is in turn conducted through the stylus to a crystal within the probe housing. The crystal transducer converts the mechanical energy into an electrical signal. Solid-state circuitry within the probe amplifies the signal for introduction into the translator.

Two inspection problems for which the contact probe has application are internal leaks in fluid power and transfer components and wear or deterioration of large ball and roller bearings. This latter application requires repetitive, comparative inspections and considerable skill and experience on the part of the operator.

Item Name: Ultrasonic Translator Detector

Manufacturer: Delcon Division  
Hewlett Packard Corporation  
Mountain View, California 94040

Part/Model No.: 4918A

Figure No.: 32

Size: 9 in. x 8 in. x 7.5 in.

Weight: 9 lb

Power Requirements: 2 each mercury batteries (expected life of 500-700 hours)

Cost: Basic Unit - Approximately \$850.00  
Contact Probe - Approximately \$200.00

Current Users: U.S. Air Force  
U.S. Navy  
Commercial users

FSN: 6635-960-5065

MIL Spec: Unknown

Operating Environment: Basic unit has hermetically sealed power switch and is internally grounded for safe operation in the presence of volatile or explosive gases (hazardous environments). The probe is suitable for temperature 0° to 1350°F.

Method of Operation: The model 4918A Detector may be used to inspect for antifriction bearing deterioration and for fluid or gas leakage.

Bearing Deterioration: The contact probe is used, and in order to obtain reputable data, a normal or standard reference must be established. This is achieved by monitoring the ultrasonic noise produced by a known good bearing and recording meter readings for specific settings of the gain control. A good bearing is characterized by a low dB reading on the meter with a high setting of the gain control. Individual reference readings are required for each bearing when this technique is used in preventive maintenance programs. A log of each bearing reading should be kept and plotted so that progressive wear becomes evident.

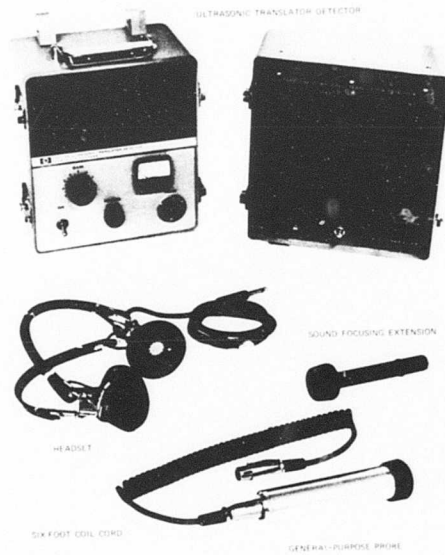

Figure 32. Ultrasonic Translator Detector.

In routine checking for faulty bearings, the need for the standard reference is not necessary. In this case, several readings are taken at intervals of  $90^\circ$  to each other. Equal meter readings in all positions indicate bearing uniformity. The relative amplitude is dependent upon the size and type of bearing. Unequal readings at different points indicate bearing instability, and a fluctuating meter reading indicates the degree of that instability in the bearing. An average or steady meter reading is a measure of friction and bearing wear. Random fluctuations indicate scored or cracked balls, while cycle fluctuations indicate a scored race or shaft.

Leakage: The inspector sequentially pressurizes and actuates various sections of the system during which time individual components are inspected for internal leakage. The component inspection is accomplished by pressing the probe stylus against the pressurized (but non-actuated) component and observing ultrasonic sound emissions, via the meter or earphones, as indicative of internal leakage. The inspector would normally scan the component listening for a perceivable noise, or "hiss". Further isolation of the leak would be accomplished by using the meter and various "GAIN" control settings to reduce the effect of extraneous noise sources.

Capabilities/Limitations: Detects ultrasonic noise in the bandwidth of 36,000 hertz to 44,000 hertz and converts it to an audible frequency in the range of from 100 to 4000 hertz. Relative characteristics are retained so that the characteristics and amplitude of the ultrasonic noise can be analyzed. Two probes are available. The General Purpose Probe is used for detecting ultrasonic energy in the atmosphere such as the sound of escaping gas. The Contact Probe detects ultrasonic energy in metallic structures such as those emitted by internal leaks in fluid systems and those generated by faulty mechanical devices such as bearings. Several adjacent leaks can be singled out because of the directivity of the probe. Minimum field-detectable leak rate is 0.1 cc/sec. Other potential applications include the detection of high-voltage electrical discharges. Calibration limited to a functional check to verify operation.

Skill/Training Requirements: Personnel using the Ultrasonic Translator Detector to inspect fluid systems for internal leaks would require some on-the-job training to familiarize them with the characteristics and magnitude of the sounds emitted by various type of leaks. They would also require a knowledge of the system being inspected in order to develop a thorough and systematic fault isolation procedure.

#### Temperature Indicating Tabs

Temperature indicating tabs are self-adhering plastic labels which consist of one or more heat sensitive indicators sealed under transparent, heat-resistant windows. The centers of the indicator circles are normally white, and turn black at the temperature rating of the tab. When a tab incorporates a multiple number of windows (usually four), each successive window is rated at a progressively higher temperature. In this way, it is possible to determine the actual temperature reached by the test object within a narrow margin. For example -- a label having windows rated at 280<sup>o</sup>, 290<sup>o</sup>, 300<sup>o</sup>, and 310<sup>o</sup>F has the 280<sup>o</sup> and 290<sup>o</sup>F windows darkened. This indicates that maximum temperature experienced by the test article was between 290<sup>o</sup> and 300<sup>o</sup>F.

The change to black is irreversible and registers the temperature history of the workpiece. An exposed tab can be made part of the permanent record by removing it and affixing it to the service report.



Method of Operation: The surface to which the temperature indicating tab is to be applied must first be cleaned of all grease, oil, dirt, etc., to obtain maximum adhesion. A self-adhesive film is on the tab's backside, and one or more heat sensitive indicators are on the front side. The indicators are sealed under transparent, heat-resistant windows. When temperature rises to level of rating printed on face of label, the centers of the indicator circles will turn black. The change to black is irreversible and registers the temperature history of the monitored object.

The label can be attached to a bearing hanger or bearing outer race. In position, it monitors safe operating temperature of the bearing. When the safe operating temperature of the bearing and hanger is exceeded, it provides a nonsubjective indication. The system is then thoroughly inspected for cause; bearing wear, misalignment, etc.

Capabilities/Limitations: Temperature indicating tabs are available to monitor temperatures in a range from 100°F to 550°F. Accuracy is plus or minus 1 percent of the stated temperature value. The tabs are available with one indicator window or four. Those with four allow determination of actual temperature within a narrow range, i.e., between rating of exposed indicator and rating of next indicator not yet exposed. The performance is not affected by transient contact with solvent, gasoline, oil, hot water or steam.

Skill/Training Requirements: No interpretation of the temperature label is required. No specialized training is required.

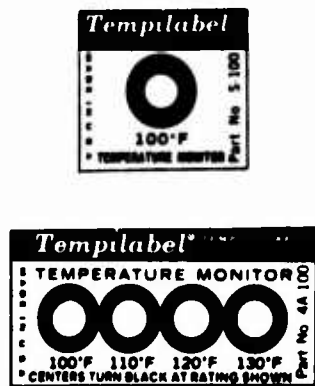

Figure 33. Temperature Indicating Tabs.

## Temperature Indicating Lacquer

Temperature indicating lacquers are compounds specially formulated to melt (after drying) at specified temperature levels and to give permanent evidence of having melted.

The typical process involves first cleaning the surface of the test article to which the lacquer is to be applied. All grease, oil, dirt, etc., must be removed. Lacquer is then applied either by brush or spray (aerosol cans are available). The lacquer dries quickly to a dull, opaque finish. On subsequent heating to the specified temperature, it will melt.

On cooling, it does not revert to its original appearance, but remains glossy-transparent. Periodic visual checks are thereafter made for this condition, indicating the predetermined temperature has been reached.

Currently available lacquers are suitable for monitoring temperatures in a range from 100°F to 2500°F. Several lacquers each with a different rating, may be applied to the same inspection article. This allows determination of the actual temperature indicating tabs.

Item Name: Temperature Indicating Lacquer

Manufacturer: Omega Engineering Incorporated  
Stamford, Connecticut 06907

Part/Model No.: Specify temperature desired. Figure No.: 34

Size: 2 oz bottle, pint can, or 16 oz aerosol can

Weight: Unknown

Power Requirement: Not applicable

Cost: 2 oz bottle - Approximately \$ 2.50  
pint can - Approximately \$15.00  
aerosol can - Approximately \$11.00

Current Users: U.S. Navy  
Commercial companies

FSN: Unknown

MIL Spec: Unknown

Operating Environment: Suitable for monitoring temperature up to 2500°F.

Method of Operation: The surface to which the lacquer is to be applied must first be cleaned to remove all grease, oil, dirt, etc. Shake or stir to ensure uniform dispersion of the suspended solids. Spray or brush on surface to be monitored. A light coat is preferable to a heavy one. The applied lacquer will dry almost instantly to a dull opaque finish. On subsequent heating to the specified temperature, it will melt. On cooling, it does not revert to its original appearance but remains glossy-transparent.

Capabilities/Limitations: Temperature indicating lacquer is available to monitor approximately 100 different temperatures in a range from 100°F to 2500°F. Accuracy is plus or minus 1 percent of the stated temperature value. Color changes take place in the lacquer coating during the heating process. These changes are insignificant, but may be misinterpreted as indicating the specified temperature has been reached.

Skill/Training Requirements: Skill and training requirements are minimal.



Figure 34. Temperature Indicating Lacquer.

## Temperature Indicating Crayons

Temperature indicating crayons perform in much the same manner as temperature indicating lacquers in that they melt when a specific temperature is encountered.

Currently available crayons are suitable for monitoring temperatures in a range from 100<sup>o</sup>F to 2500<sup>o</sup>F. Unlike temperature crayons are normally used to check temperatures on a one-shot, real-time basis. As with tabs and lacquers, crayons are accurate within plus or minus 1 percent of the specified temperature.

Item Name: Temperature Indicating Crayon

Manufacturer: Omega Engineering, Incorporated  
Stamford, Connecticut 06907

Part/Model No.: Specify temperature desired      Figure No.: 35

Size: 0.5 in. dia. x 6 in.      Weight: Several ounces

Power Requirements: Not applicable

Cost: \$2.50 each

Current Users: U.S. Navy  
Commercial companies

FSN: Unknown      MIL Spec: Unknown

Operating Environment: Suitable for measuring temperatures up to 2500<sup>o</sup>F.

Method of Operation: Omega temperature indicating crayons come in an adjustable metal holder. In use, the part being monitored is stroked from time to time with the crayon during the heating process. Below its temperature rating, the crayon leaves a dry (chalky) mark. When its rating is reached, the crayon leaves a liquid smear.

Capabilities/Limitations: Temperature indicating crayons are available to monitor approximately 100 different temperatures in a range from 100°F to 2500°F. Accuracy is plus or minus 1 percent of the stated temperature value. Color changes take place in the chalky mark during heating process. These changes are insignificant, but may be misinterpreted as indicating the specified temperature has been reached. The part to be monitored must be accessible during operation, or immediately upon aircraft shutdown.

Skill/Training Requirements: Skill and training requirements are minimal.



Figure 35. Temperature Indicating Crayon.

### Reed Vibrometers

The tuned reed principal forms the basis for the vibrometer's action. This principal states that a reed, free at one end, will vibrate at a single fundamental frequency, depending upon its length. The vibrometers reported upon on the following pages utilize a steel strip as a reed and incorporate mechanisms which can extend or retract the strip, thus varying the reed's natural frequency.

In one of several possible applications, vibrometers are used to monitor the condition of rotating bearings (ball or roller).

With such items, it is possible to relate frequency changes to specific types of bearing degradation. This is not a simple process and usually involves much experimentation by engineering personnel under laboratory conditions. Once acceptable/nonacceptable signals are established and recorded for a given bearing, vibrometers become a useful inspection device in the hands of an experienced inspector.

The reed vibrometer can be effective as an inspection device only if:

1. Much preliminary work is accomplished to establish acceptable/nonacceptable signals for each item to be inspected, and
2. the inspection task is assigned to an inspector thoroughly familiar with the operation of the vibrometer.

Acceptable/nonacceptable limits are best determined and documented by engineering specialists.

The mechanic assigned to carry out the inspection must be capable of detecting subtle changes in the vibrometer's signals. He must be skilled and experienced enough to relate each signal to a particular operating condition of the test article. Little formal classroom instruction is required, but considerable on-the-job training is desirable to develop skill and experience.

Item Name: Reed Vibrometer

Manufacturer: Korfund Dynamics Corporation  
Westbury, Long Island, New York

Part/Model No.: 120-15,000 CPM Vibrometer Figure No.: 35

Size: 9.25 in. x 1.625 in. x 1.0 in. Weight: 1 lb

Cost: Approximately \$75.00

Current Users: U.S. Navy  
Commercial companies

FSN: Unknown

MIL Spec: Unknown

Operating Environment: Temperature limited by operator's tolerance. Does not introduce heat or electrical connections into areas being inspected. May be used safely in hazardous gas environments.

Method of Operation: The Korfund vibrometer has a reed in the form of a steel strip whose length can be varied by means of a knurled thumb nut (control knob) on the side of the instrument, thus varying the reed's natural frequency.

To determine a vibration's frequency, the probe of the vibrometer is held against the vibrating body and the reed is gradually fed out, starting from the fully retracted position.

When the reed shows a tremor, it is "fine tuned" by slowly turning the control knob back and forth until maximum movement is noted.

The scale marker on the handle directly indicates the frequency; no calculations or intermediate steps are needed. An amplitude comparator scale permits plotting the amplitude variations of the reed for different frequencies.

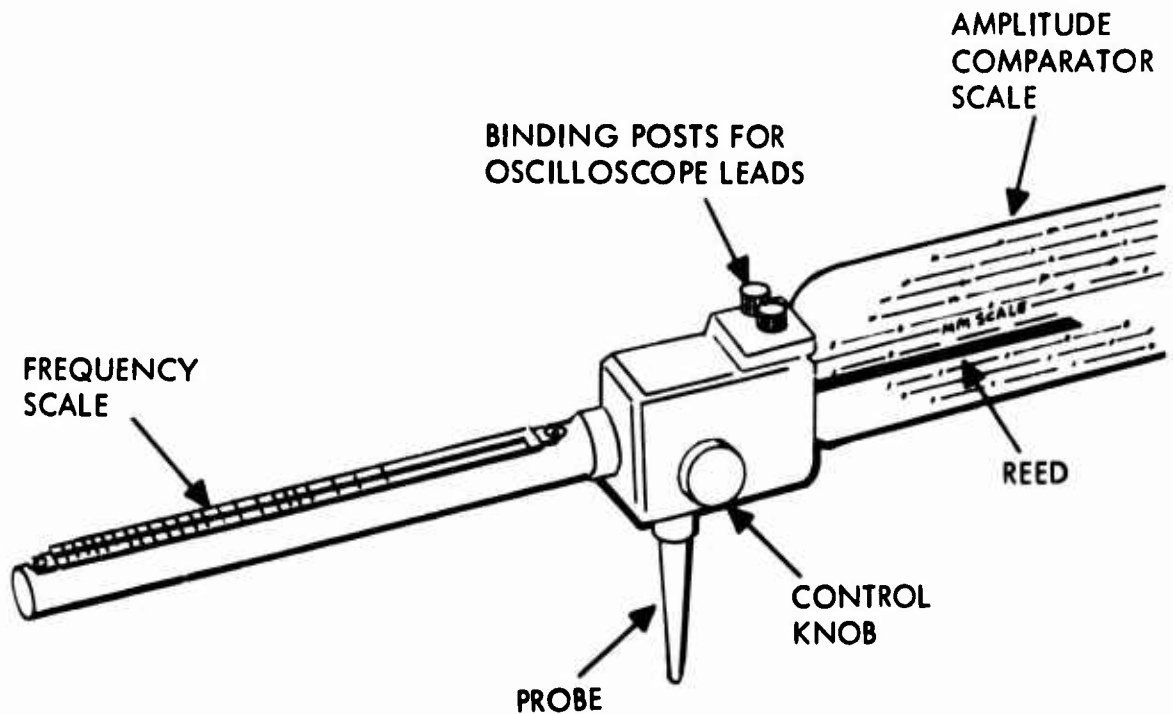

Figure 36. Reed Vibrometer, Korfund Dynamics Corporation.

The vibrometer has a built-in electromagnetic pickup whose output can be easily applied to an oscilloscope or oscillograph by means of two binding posts on the meter, if it is desired to display or permanently record the vibratory phenomena observed.

Capabilities/Limitations: The Korfund Reed Vibrometer has a full frequency range from 120 to 15,000 cpm. This is accomplished by using a weighted reed for frequencies between 120 and 600 cpm, and a free reed for frequencies between 600 and 15,000 cpm. It is accurate within  $\pm 3$  percent with the free reed, and  $\pm 10$  percent at all frequencies with the weighted reed.

For very low frequencies, a calibration chart is provided. A scale marker on the handle indicates the frequency as a direct reading. Visual and manual access to the part to be inspected is required. The instrument is hand-held and is extremely portable.

Item Name: Reed Vibrometer

Manufacturer: The Vibroscope Company, Incorporated  
West Hurley, New York 12491

Part/Model No.: Model-NR with Low Frequency Option

Figure: 37

Size: 2.5 in. x 1.0 in. x 0.5 in.      Weight: 7 oz

Cost: Approximately \$60.00

Current Users: U.S. Navy

FSN: 6680-273-8748

MIL Spec: Unknown

Operating Environment: Temperature limited by operator's tolerance. Does not introduce heat or electrical connections into area being inspected. May be used safely in hazardous gas environments.

Method of Operation: The instrument is operated by holding it in contact with the vibrating body. Turning the knurled knob will feed out a steel reed from the body of the instrument and at the same time rotate the dial which is graduated in frequencies

per minute. As the reed approaches the length where it will vibrate at the same frequency as the machine vibration, there will be a tremor at its end. On slight further adjustment the reed vibration will build up sharply to a maximum amplitude. The vibration frequency per minute is then read directly on the graduated dial.

Capabilities/Limitations: The graduations on the dial run from 450 per minute to 20,000 per minute. The scale is logarithmic in nature, which means that it is wide at the low end and narrows down as the frequency increases.

A vibration of 0.001 inch double amplitude will produce a vibration of approximately 1/2 inch double amplitude at the end of the reed. Above 6000 cycles per minute, this response diminishes gradually. At 20,000 cycles per minute, it is approximately 3/16 inch per 0.001 inch. The reed amplitude produced by a given vibration will repeat with absolute reliability. A double amplitude of 0.0001 inch may be detected clearly.

The vibrometer may be provided with a small weight which may be clipped to the end of the reed. With this in place, the lower range of the instrument is extended down to 225 per minute. When the weight is in use, the frequency reading as shown on the dial must be divided by 2.

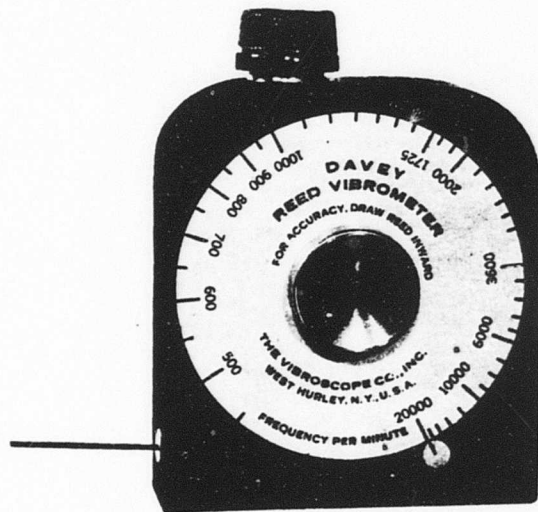

Figure 37. Reed Vibrometer.

## SLIPPAGE MEASUREMENT - TORQUING

The current inspection methods for structural fasteners (tail boom attachment fittings) are time consuming and inconclusive. The object of the inspection is to determine if the structural fasteners have the proper preload. Present inspection methods rely on indirect indicators such as torque loads and/or slippage marks to denote proper bolt tension. Maintenance history records indicate that 34 percent of failures are from inadequate bolt preload.

All aircraft inspections check fittings and bolts for slippage. Requirements indicate that a broad range of torque specifications must be met. This also indicates that several different torque wrenches are required. Their accuracy should be  $\pm 10$  percent of final torque value. Currently, the concept utilizes a visible indicator (slippage mark) which shows if relative motion has occurred between the fastener and its joint and/or directly determines bolt torque (retorquing with a torque wrench).

A typical application of slippage measurement is the tail boom attachment fittings for the UH-1 aircraft. The upper bolts are torqued to 770-950 inch-pounds and the lower bolts are torqued to 240-270 inch-pounds.

Investigation of slippage measurement (torque condition) has included marking paints, labels using ultraviolet light inspection, and torque strip indicators built into the head of bolts. The latter are based on a photoelastic strip which turns color when in the appropriate torque range or can be interpreted via fringe order in polarized light. A type of bolt known as torque-set was also investigated.

These techniques or devices do not provide the solution to the whole problem. The area of consideration is not slippage, relative motion or torque level, but bolt preload or tension.

In most torquing situations, resistance is met. The elements comprising this resistance are burrs, damaged threads, rust, washer or surface hardness and misalignment of joint elements. These elements permit the fastener torque requirements to be met while the joint is not tight.

These elements detract from the key indicator, namely, bolt tension or preload. Hence, the bolt can be tight according to the specification while the joint is loose.

Due to the vibration and shock levels encountered in helicopter inspection, it is essential that all joints be tight. The primary indication of tightness is proper bolt tension. When this level is achieved, the joint is considered tight even if slippage does occur. The technique resolving joint tightness is to utilize a bolt preload indicator in all critical bolts.

Item Name: Tell-Torq Bolt

Manufacturer: Modulus Corporation  
1000 Modulus Road  
Mount Pleasant, Pennsylvania 15666

Part/Model No.: Dependent on bolt to be replaced.

Figure Nos.: 38, 39

Size: Same as bolt to be replaced      Weight: Same as bolt  
to be replaced

Power Requirements: None

Cost: Approximately double that of present bolt

Current Users: Unknown

FSN: None

MIL Spec: None

Operating Environment: The temperature is limited to the range of  $-10^{\circ}\text{F}$  to  $175^{\circ}\text{F}$  due to the fluid indicator. A special extended temperature device is available with a range of  $-60^{\circ}\text{F}$  to  $400^{\circ}\text{F}$ . The device may be used in hazardous environments.

Method of Operation: Replace all bolts in question with Tell-Torq bolts of the same type, size and strength.

When this bolt is tightened to a prescribed stress load, the optical color indicator located in the head of the bolt changes to black.

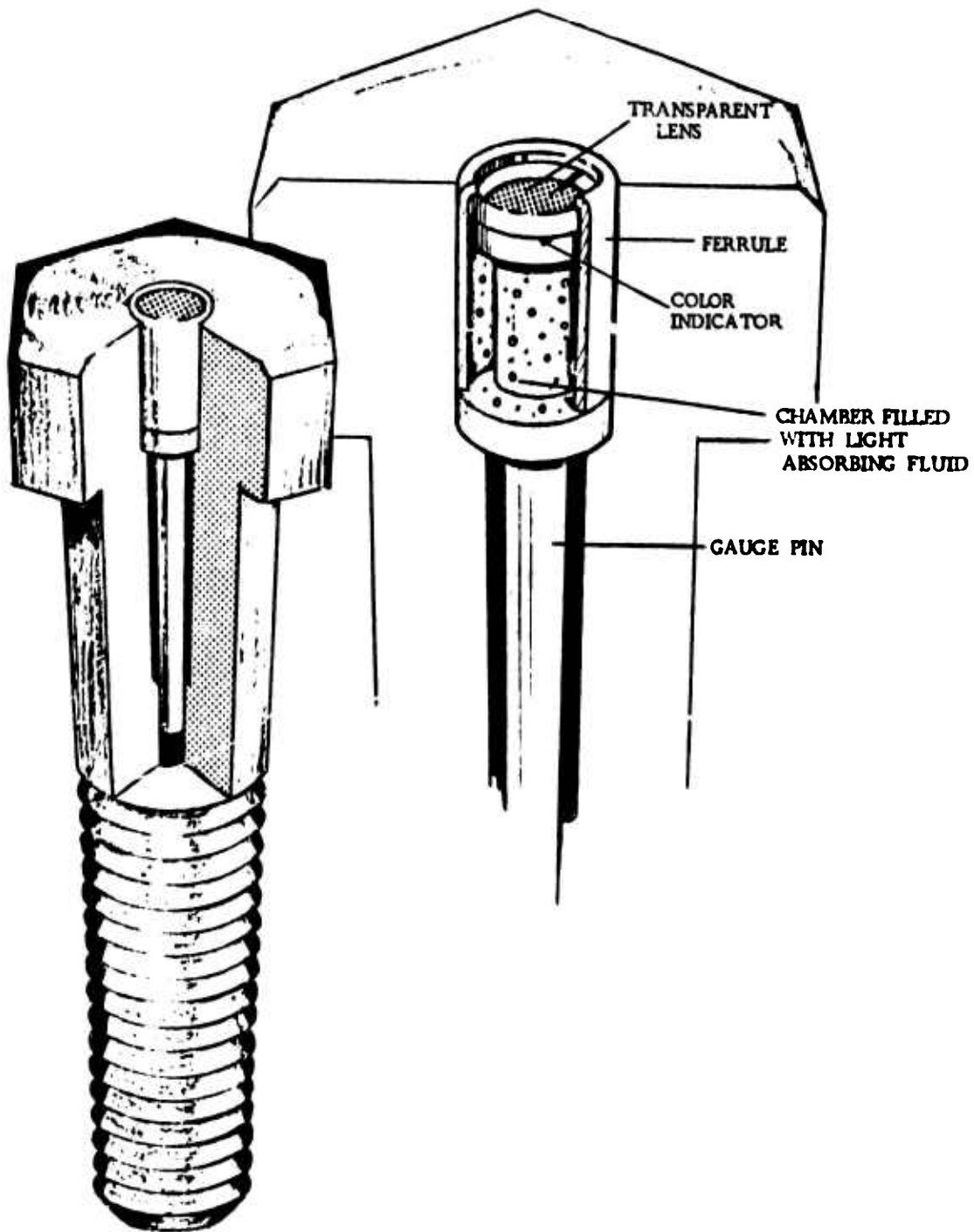
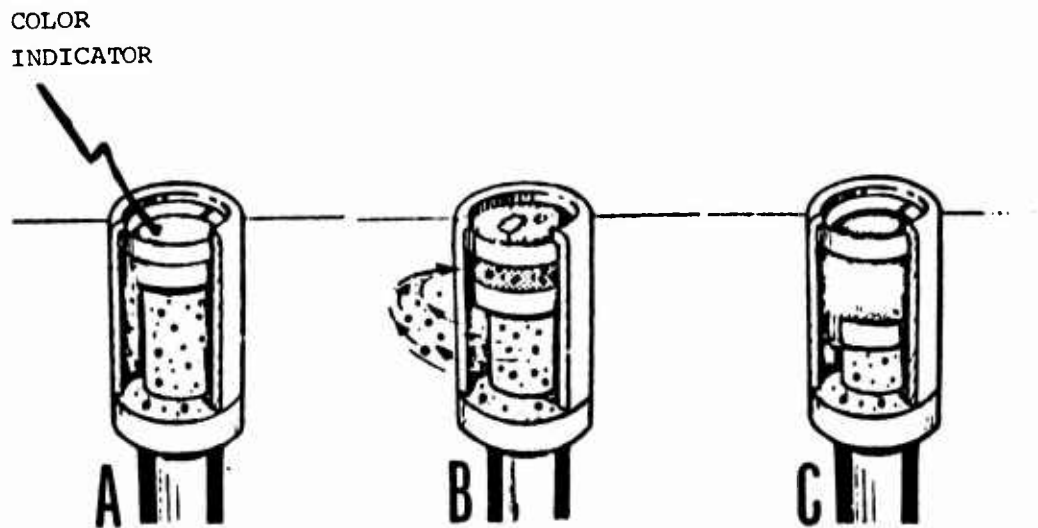

Figure 38. Major Elements of Tell-Torq Bolt.



A. Loose Condition (Bright Red Center)

Observer sees bright reflective red color, clearly visible when the head of the gauge pin rests flush against the inner surface of the tempered plastic viewplate.

B. Partially Tightened Condition (Dark Red Center)

Observer sees darkening of the red color. This occurs when gauge free at both head and tip, moves away from the lense as the bolt elongates under tightening. As the clamp load increases, increasing amounts of dark blue fluid in the chamber comes between the lense and the red-headed pin.

C. Fully Tightened Condition (Black Center)

Observer sees dark blue or almost black color. When the fastener is tightened to its full design load, threads fully engaged along its grip length, the fluid completely obscures the red top of the gauge pin.

Figure 39. Tell-Torq Indicator - Inspection Conditions.

Inspection of the bolt to ensure tightness is visual and therefore rapid. The inspector would retighten only those bolts in which the optical indicator is red. See Figure 39.

The Tell-Torq bolt is reusable as long as it is not stretched beyond its elastic limit.

Capabilities/Limitations: The Tell-Torq bolt is a simple, durable and reliable indicating system adaptable to an extensive variety of fasteners. It can be easily incorporated into aircraft type hardware covering a wide range of size and materials.

The efficient way of tightening a Tell-Torq bolt is with an open end or box end wrench and not with the more readily usable socket-ratchet wrench.

Using a box wrench enables the individual to view at all times the optical indicator.

Skill/Training Requirements: The installation, inspection and adjustment of the Tell-Torq fastener system is simple and straightforward. The bolt head indicator is displayed directly to the viewer, and no interpretation of the indicator is required. No specialized training is required.

Item Name: Visual Preload Indicator

Manufacturer: IIT Research Institute of Chicago (under laboratory development)

Part/Model No.: N/A

Figure No.: 40

Size: All standard bolt sizes accommodated

Power Requirements: Polarized Light Source

Cost: Not available

Current Users: N/A as product is under development

FSN: None

MIL Spec: None

Operating Environment: The temperature range of the Photoelastic Strip Tension Bolt will be limited by the operating range of the reflective cement and the photoelastic material utilized. Firm figures are not currently available.

Method of Operation: Bolt preload or tension can be indicated via a photoelastic fringe system under development by IIT Research Institute of Chicago. Their system involves fastening a thin strip of photoelastic material to the bolt head with a reflective cement as illustrated in Figure 40. When the bolt is under tension, the inspector shines a polarized light source on the bolt head and views the pattern or fringe order. The fringe order seen on the strip is directly related to bolt tension through a simple calibration curve. Accuracy is 2 to 5 percent. Inspection of the bolt to ensure tightness is visual and therefore fairly rapid. The inspector need only retighten those bolts which indicate a lesser tension than required. A bolt of this type is reusable as long as it is not stretched beyond its elastic limit.

Capabilities/Limitations: The Visual Preload Indicator Bolt appears difficult to use in many aircraft applications where limited access occurs. The inspector must shine a polarized light source on the bolt while torquing and viewing the fringe pattern. This will either require the use of a box wrench or an open end wrench or a multistep tightening process. The latter process would utilize incremental tightening with removal of the socket ratchet wrench each step to view the fringe pattern. The visual preload indicator does not detract from the overall bolt strength. The cross-sectional area is not affected. This is a distinct advantage over the Tell-Torq system.

Skill/Training Requirements: Matching the indicated fringe pattern on a bolt with the one desired will require some on-the-job training. The difficulty of performing this task will be related to the ease of viewing the fringe pattern in the final developed pattern.

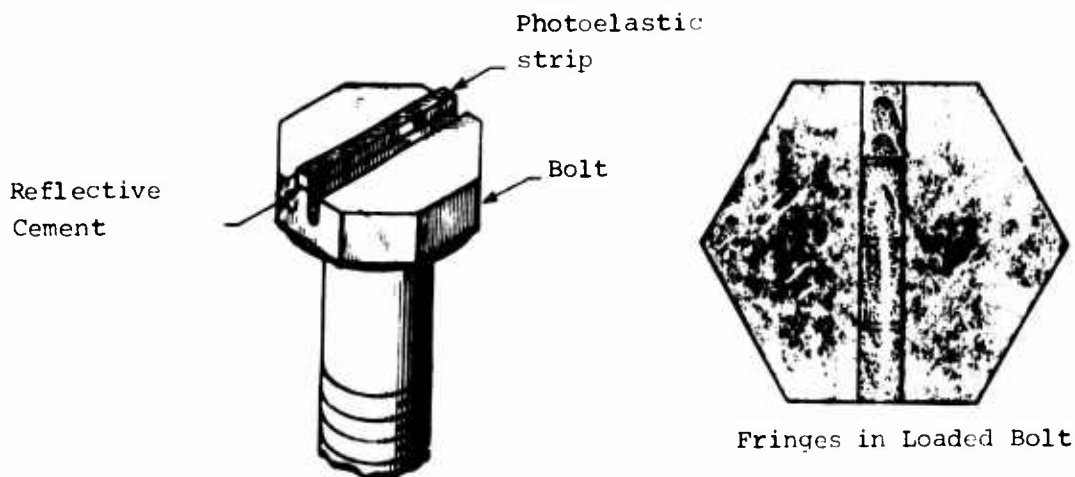

Figure 40. Photoelastic Strip Tension Bolt.

### SLIPPAGE-POSITIONAL MEASUREMENT

Slippage marks show relative movement between parts which should normally be stationary with respect to one another, such as a bearing outer race and its hanger or a nut or bolt head and the surface it is bearing against. In the former case, slippage is an indication that the internal bearing friction force is larger than the force retaining the outer race in the hanger. This could indicate imminent bearing seizure, loss of hanger preload or excessive shaft speed. The latter condition indicates complete loss of fastener preload which could result in a structural failure.

Other uses for slippage marks include marking gages and field calibrated adjustments. Here slippage is a failure mode not an indicator of some other failure mode.

All aircraft require inspection of fittings and joined assemblies for slippage. Requirements indicate a need for a clearly visible and easy to spot (simple to interpret) indicator which will show if relative motion has occurred between the two parts of an assembly (as in the case of hanger bearing preload mentioned above).

Investigation of positional slippage indicators has included felt tip ink marking, tear-apart quality control labels, marking paints, and labels using ultraviolet light for inspection.

The difficult detection of slippage in concealed bearing supports, hangers or in fasteners is compounded due to obscurity

of the locations or difficulty of reaching the positions.

One instrument that facilitates the examination of slippage in addition to other uses (such as the detection of corrosion in inaccessible areas, i.e., between the stringers and skin in the tail boom and between the bulkhead and skin) is a fiber optics device known as a peeperscope. This instrument enables a mechanic to remotely inspect bearing hangers or fasteners.

One of the characteristics of bearing-hanger slippage is friction. An increase in friction in any bearing results in the generation of heat. This could indicate imminent bearing seizure. One sample indicator of imminent bearing seizure is a temperature sensitive label that changes color with a temperature increase. This is a nonsubjective, go/no-go device that could be attached to every bearing hanger.

It is recommended that the development of a device with broad application and nonsubjective interpretation be initiated. This would be a simple, low-cost label that would indicate if slippage load occurred or if bearing seizure is imminent. One device would suffice for both applications.

Item Name: Indicator Label (Developmental Item)

Manufacturer: None

Part Number: None

Size: 1 in. x 1/2 in.

Figure No.: 41

Power Requirements: None

Weight: Negligible

Cost: Approximately \$3.00 each

Current Users: None. Part not designed.

FSN: None

MIL Spec: None

Operating Environment: This label would have an upper temperature limit of 350°F, the operational limit of a bearing hanger. The labels would have no practical lower limit. These labels would use no electrical power and could be used in hazardous gas environments. The performance would not be affected by transient

contact with contaminants such as solvents, gasoline, fuel oil, lubricants, hot water and steam.

Method of Operation - Development Discussion: The development of a multiple usage, go/no-go label applicable to many types of slippage problems is needed. Two problems not resolved by the presently available designs are:

1. Slippage can occur without the overheating of a bearing hanger or race. Detection is difficult.
2. Nighttime and daytime inspection and maintenance requires high visibility of the indicator located in relatively hard-to-reach places.

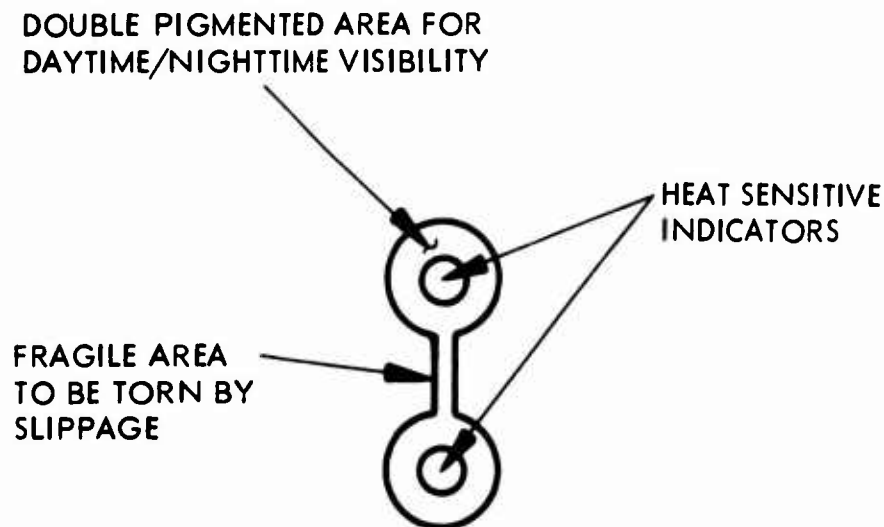

Figure 41. Temperature/Slippage Indicator Label.

The design of the indicator would encompass the following areas:

1. Adhesive - peelable back, pressure sensitive, high initial tack, permanent, wide temperature range.
2. Facing - paper and/or plastic readily torn by a small shift in adjacent parts such as bearing race and hanger.
3. Facing Color and Sensitivity - double pigmented in di-  
glo orange or yellow and fluorescent yellow and contain-

ing two heat sensitive indicators sealed under transparent, heat-resistant windows.

This device would be inexpensive, extremely versatile, and easily mass produced.

Capabilities/Limitations: Capable of indicating in a nonsubjective manner slippage and overtemperature. This device also would be readily discernible in nighttime as well as daylight. It would be inexpensive and easy to install.

Skill/Training Requirements: Installation and interpretation of this label is simple. No specialized training is required; however, the user must know the location of the areas utilizing these devices.

### ALIGNMENT MEASUREMENT

Telescopes, optical viewers and borescopes are used for many alignment checks. Variation of the borescope can be designed to solve a specific alignment problem. However, alignment requirements in the aircraft TM's appear to be adequately met by existing tools. Where alignment procedures such as loose fit run-in or tail rotor shaft bearings are used, subsequent misalignment can be rapidly detected by the vibrometers described in the section on flexing.

Specialized alignment problems such as landing gear alignment/spread measurement techniques can be simplified and improved. An example of this is the alternative measurement technique described below for the UH-1 landing gear spread check.

The alignment of tail rotor shaft and gearboxes on the UH-1 and AH-1 aircraft uses numerous fixtures and adapters (42° and 90° gearboxes). However, a simple technique replacing some of these fixtures does not appear practical from an economic standpoint. The instrument accuracy required is noted to be +0.007 DIA.

The real issue is the subjectivity involved in ascertaining just when or if alignment inspections are really needed. The two categories discussed below are simple and nonsubjective and consume much less time than present methods.

## Landing Gear Spread Alignment Check

The periodic inspection checklist for OH-58, UH-1, and AH-1 requires that the landing gear spread and alignment be checked. This requires that the aircraft be jacked off the ground, one man working under the aircraft and one next to the skid; the procedure requires approximately 90 minutes per aircraft.

A less time-consuming method which would tend to yield more accurate results is described below:

1. Roll aircraft, fully fueled, to a smooth, hard level surface and remove ground handling wheels.
2. With a plum bob and a tape measure with a hook end, measure distances A, B and C per Figure 42 at front and rear cross tubes.

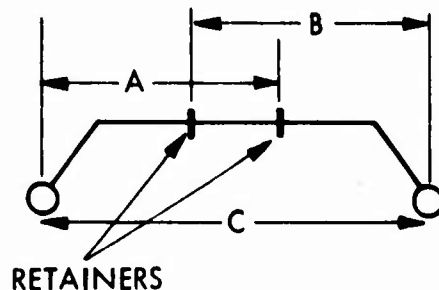

Figure 42. Landing Gear Spread Measurements.

3. "C" must be greater than S minimum but less than S maximum. (See Table VIII.)
4. The magnitude of A-B must be less than, or equal to  $D - |S_{AV}| - C$

TABLE VIII. LANDING GEAR SPREAD SPECIFICATIONS			
Aircraft*	OH-58	UH-1	AH-1
S Minimum	74.5	96	80
S Maximum	76.5	100	82
S <sub>AV</sub>	75.5	98	81
D	1.0	2.0	1.0

\*Data shown is for unloaded condition; new data will be required for loaded condition. Differences of A front and A rear or B front and B rear show the amount of nonparallelism between the aircraft axis and the gear.

### Shock Indicators

The most subjective area of aircraft maintenance involves the issue of when to inspect the aircraft for possible damage due to a hard landing. Investigation shows that some landing gear inspections need not be performed as frequently as recommended as long as normal aircraft use is maintained. However, field and war use conditions make "normal use" all the time improbable. Hard landings can easily be detected via installation of a latchable shock indicator. Whenever the shock indicator is energized, a thorough landing gear inspection can be performed.

Investigator shock indicators included a number of latching accelerometers of the following types: a spring loaded weight, a magnetic ball and a recording cantilevered weight. All of the devices operate on a similar principle. A weight is suspended via a mechanism with a certain spring constant. When a shock pulse exceeds the rating of the spring constant, the indicator trips and denotes this excess.

It is recommended that in considering a location for the mounting of these devices, a central location be found sensitive to all shock forces directly (with a minimum of damping) from the cross tubes. The recommended place for OH-58, UH-1 and AH-1 aircraft is on the canted center post. (See Figure 43.) It is also recommended that indicators be used sensitive to the four shock directions indicated. It should be noted that some investigation must be accomplished to ascertain just what "safe" or "excessive" shock levels are to be considered as limitations. Once this factor is established the shock indicator can be completely specified.

Direction of shock pulses  
to be sensed

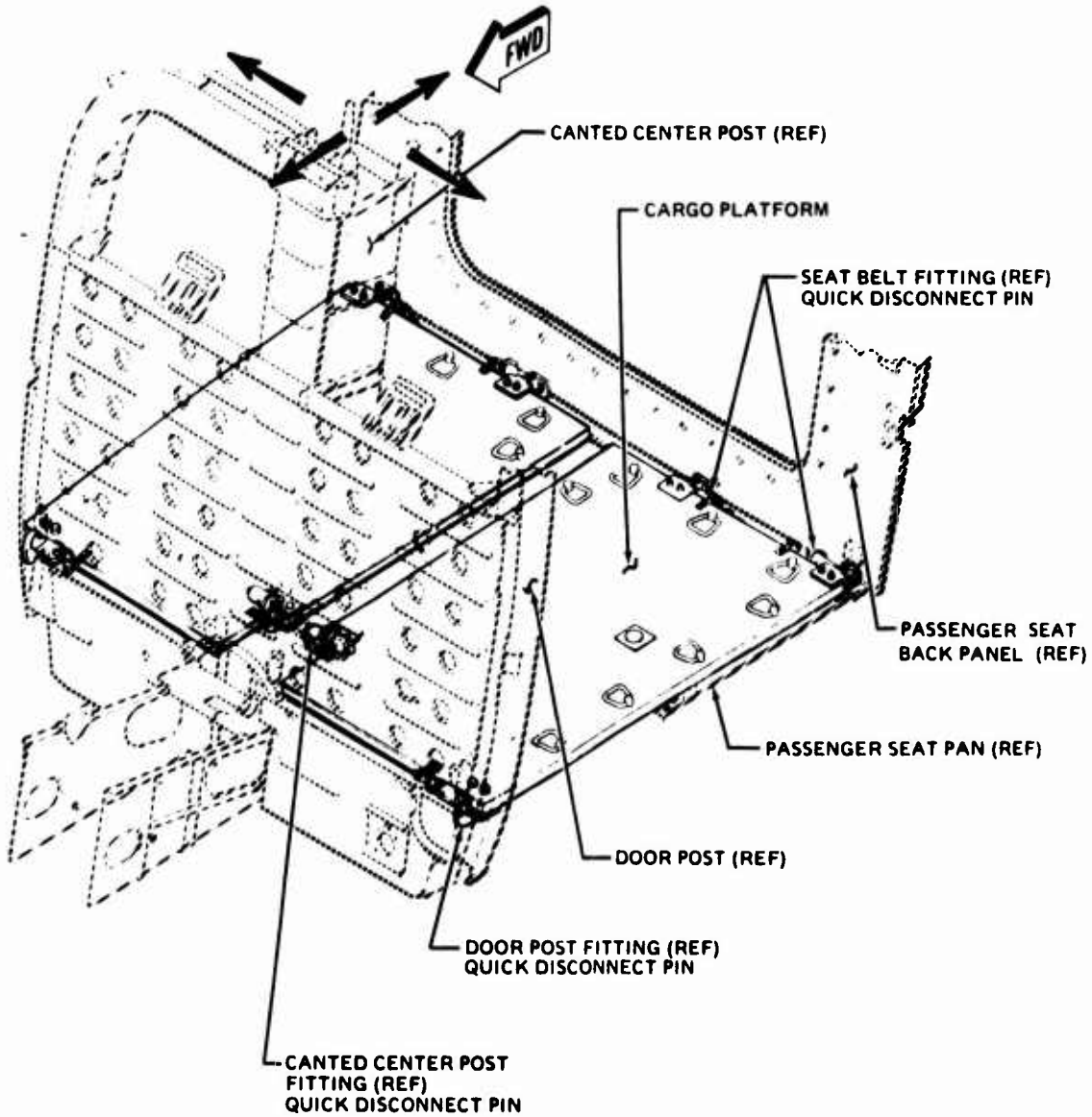

Figure 43. Shock Indicator Location.

The shock indicator instruments which are presented on the following pages are capable of recording and readily indicating whether or not the "safe" shock loading of the cross tubes has been exceeded. They require no pilot attention. They can easily be read by helicopter maintenance personnel to determine when pre-established "G" levels have been exceeded.

Item Name: Planar Accelerometer

Manufacturer: Humphrey Incorporated  
San Diego, California 92106

Model No.: PA03-0102-1 Figure No.: 44

Size: 4.62 in. x 4.25 in. x 2.31 in. Weight: 0.5 lb

Power Requirement: None

Cost: \$50.00 each

Current Users: Unknown

FSN: None

MIL Spec: Unknown

Operating Environment: The temperature range is limited to -30°F to +160°F. It may be used anywhere a helicopter can travel.

Method of Operation: Two of these units would monitor the shock pulses indicated in Figure 43. The accelerometer consists of a seismic mass suspended from a cantilevered wire spring. This type of suspension allows sensitivity to all directions of accelerations in a given plane. A stylus traces the magnitude of the acceleration or shock pulse on a replaceable recording disc.

This unit requires no manipulation once it is installed and provides a direct recording of shock level with immediate visual indication.

Capabilities/Limitations: The Planar Accelerometer can be over-ranged (overshocked) by five times full-scale input without damage. One limitation is an inconvenience. The recording disc must be resurfaced with a liquid after the accelerometer has been used to "reset" the instrument.

Skill/Training Requirements: No specialized training is required for either reading the instrument or for resurfacing the recording disc.

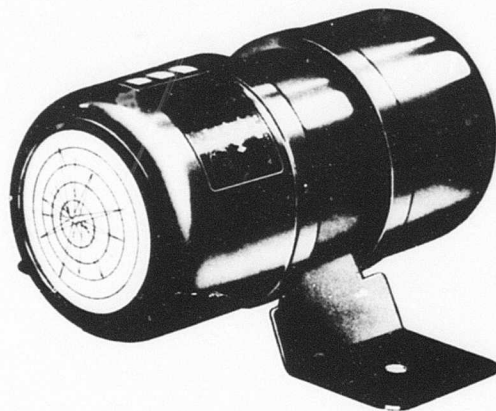

Figure 44. Humphrey Incorporated Accelograph - Planar Accelerometer.

Item Name: Dot Shock Indicator

Manufacturer: Inertia Switch Incorporated  
New York, New York 10036

Part No.: SR 345-V or H

Figure No.: 45

Size: 1-1/2 in. diameter by 1-3/8 in. length

Weight: 0.25 lb (Estimated)

Power Requirements: None

Cost: \$25.00 each

Current Users: Unknown

FSN: None

MIL Spec: Unknown

Operating Environment: The temperature range is limited to -65°F to +200°F. It may be used anywhere a helicopter can travel.

Method of Operation: Two of these units would monitor the shock pulses indicated in Figure 43. The accelerometer consists of a small ball held in place by a magnet. The ball is clearly visible under a transparent plastic cap. When an applied shock or acceleration is greater than the holding force of the magnet, the ball is forced out of its initial position and is no longer visible. This unit requires no manipulation once it is installed and provides a direct indication of excessive shock level.

Capabilities/Limitations: The Dot Shock Indicator can be obtained in a sealed tamper-proof version. It may be reset by simply unscrewing the transparent cover and repositioning the ball in the magnet with nonmagnetic tweezers. The device can be used over and over again.

Skill/Training Requirements: The reading of the shock indicator is straightforward. No specialized training is required for either reading the device or for resetting the displaced ball.



**INERTIA SWITCH MODEL SR - 355**

Figure 45. "G" Dot Shock Indicator, Inertia Switch Inc.

Item Name: Shock Overload Indicator - "Shock Master"

Manufacturer: Arizona Gear and Manufacturing Company  
Tucson, Arizona 85716

Model No.: TA280-018---C5

Figure No.: 46

Size: 1.50 in. Diameter by 1.9 in. Height nominal

Weight: 0.3 lb (Approximately)

Power Requirement: None

Cost: Approximately \$20.00 each

Current Users: Unknown

FSN: None

MIL Spec: Unknown

Operating Environment: The temperature range is limited to -40°F to +180°F. It may be used anywhere a helicopter could travel.

Method of Operation: Two of these units can monitor the shock pulses indicated in Figure 43. The accelerometer consists of a spring-loaded weight with an integral trigger which engages with a spring-loaded sleeve. When an applied shock or acceleration is greater than the restraining force of the spring, the trigger is disengaged from the sleeve, which in turn is forced by its spring to move along a rod, exposing a red warning band. This unit requires no manipulation once it is installed and provides a direct indication of excessive shock level.

Capabilities/Limitations: The Shock Master can be obtained in a sealed tamper-proof version. It may be reset by inserting a wire or straightened paper clip into a hole on the side of the dome and pushing the black sleeve back to its cocked position. The device can be used over and over again.

Skill/Training Requirements: No specialized training is required for either reading the device or for resetting the black sleeve.



Figure 46. Shock Overload Indicator, Arizona Gear and Manufacturing Company.

#### FLEXING FAULT DETERMINATION

Determination of excessive flexing or whipping in mechanical components is often difficult because the flexing occurs under operational stress conditions. Vibration sensors are suited for the indirect detection of flexing or whipping of rotating components such as the tail rotor drive shaft. Available units enable the mechanic to isolate the source and measure its amplitude and frequency.

Detection of drive shaft flexing or whipping in fully assembled aircraft is applicable to OH-6, OH-58, UH-1 and AH-1 aircraft. Currently the tail rotor drive shaft of the OH-6 is inspected during PE for obvious damage, deformation or twisting and excessive wear in the damper area. Supplementing this inspection with a simple vibrational check will, in most cases, detect a problem before obvious damage occurs.

Vibration analysis can be used to assess tail rotor drive shaft condition as well as the condition of other mechanical systems.

Under normal conditions all rotating mechanical systems acquire a characteristic vibration pattern. With usage, defects such as misalignment looseness, wear, bad bearings and deformed shafts can occur and cause excessive vibration. As these defects occur, the vibration pattern changes. The examination of the pattern change while the helicopter is operational can be used to determine if corrective maintenance is needed.

Investigation of vibration analysis has encompassed vibration meters and vibrometers. These devices solve or analyze one problem at a time (e.g., a noisy bearing) and require some interpretation. Additionally, there is a need to develop a device that can be centrally located (as on the floor of the cockpit) and give direct readouts of troublesome frequencies and directions. This simple instrument is discussed on page 158 in detail. The proposed device would indicate problems but would not measure them directly. Thus, it would not supplant the other listed vibration devices but would complement them.

Item Name: Vibration Analyzer/Dynamic Balancer

Manufacturer: IRD Mechanalysis, Incorporated  
Columbus, Ohio 43229

Model No.: 330

Figure No.: 47

Size: 8 in. x 20 in. x 15-1/1 in.

Weight: 30 lb (with  
carrying case)

Power Requirement: Battery powered (6 Mallory TR-136R)

Cost: \$4630

Current Users: Commercial companies including:

Beech Aircraft Corporation  
Boeing Company  
Timkin Roller Bearing Company

FSN: None

MIL Spec: Unknown

Operating Environment: Temperature limited to operator tolerance; may be safely used in all environments.

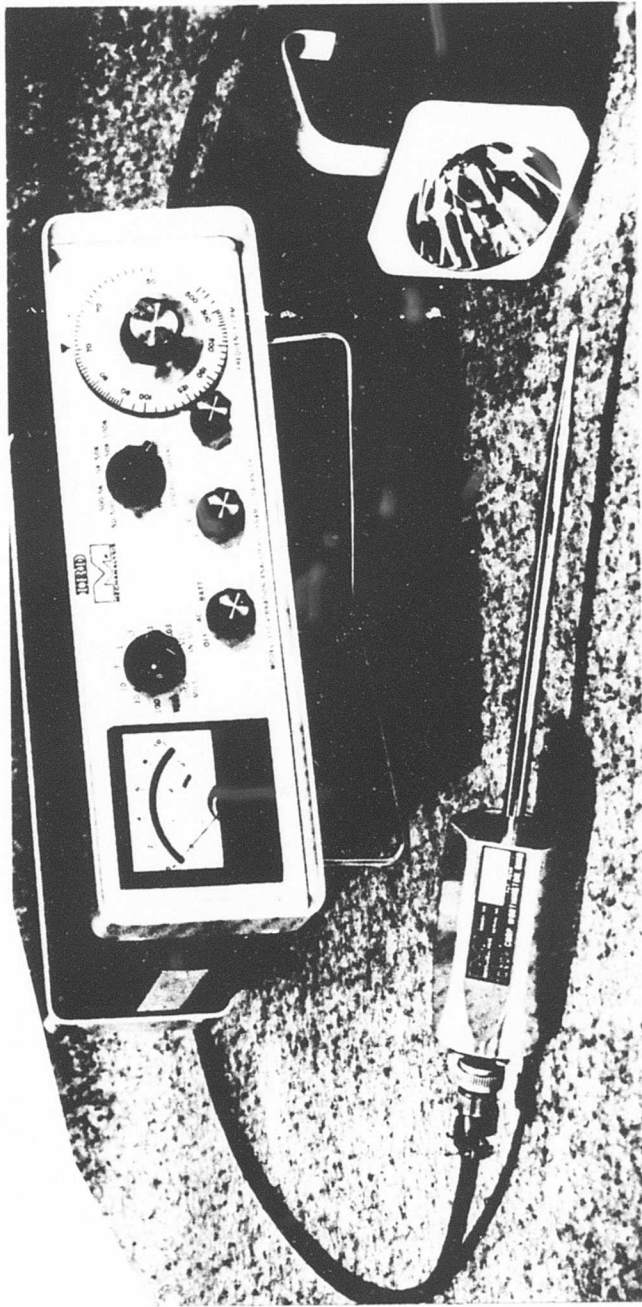

Figure 47. Model 330 Vibration Analyzer Dynamic Balancer - IRD Mechanalysis.

Method of Operation: A vibration pickup is placed against or on a component to be analyzed. The frequency of vibration is read directly out on a meter. A distinct variation from the RPM of the component indicates trouble. Displacement, the distance the vibrating part travels back and forth, is read out on another meter. The greater the reading, the more serious the mechanical trouble. A stroboscopic light is then used to illuminate the suspect area. It is automatically tuned to the setting in the frequency meter. It will visually pin-point the source of the vibration and the direction of the unbalance. Fine tuning and range selection must be adjusted on the analyzer to obtain the proper information.

Capabilities/Limitations: The vibration analyzer is capable of locating and determining the cause and magnitude of the unbalance of any rotating mechanical part on helicopters. It provides a direct readout of vibration data, and is portable and battery powered. However, the analyzer is expensive and has many components that have to be handled and positioned in order to obtain data.

Skill/Training: The operation of the vibration analyzer requires some skill and knowledge of vibration. The location of the pickup is critical and the position of the strobe light is also critical. Several switches and dials have to be manipulated. In some cases, filters have to be employed in order to select the individual vibration to be analyzed.

Item Name: Diagnostic Reed Vibration Instrument

Manufacturer: Reed Manufacturer Recommended. (Instrument is conceptual design)

Part/Model No.: N/A

Figure No.: 48

Size: Approximately 4 in. x 4 in. x  
2 in.

Weight: Approximately 2 lb

Power Requirements: None

Cost: Less than \$100

Current Users: N/A

FSN: N/A

MIL Spec: N/A

Operating Environment: Temperature limited to operator tolerance. Uses no electrical power. May be used in hazardous gas environments.

Method of Operation - Conceptual Discussion: This instrument would require a minimum of time for fault isolation and could be placed in position whenever the need arose for vibration analysis.

The structure of most helicopters is stiff and therefore readily transmits vibration without attenuation. The instrument, if mounted on the cockpit floor or vertical stiffener, would adequately reflect vibration pulses transmitted from the main rotor, main rotor blades, tail rotor assembly, tail rotor drive shaft, etc.

The instrument would consist of three cylindrical modules secured to a mounting plate (see Figure 48). Each module would consist of a balanced and weighted reed free at one end and sensitive to a particular frequency of vibration. Enclosing each reed would be a cylindrical or hemispherical, plastic, transparent dome. The dome or cover would be engraved with concentric circles. Each circle would represent a "G" load experienced by the reed while vibrating at its natural frequency. As the incident pulses cause the reed to vibrate, the displacement or excursion of the balanced reed would reflect the "G" load. The concentric circles could be calculated to read levels such as 1 "G", 2 "G", 3 "G" and thus indicate the magnitude of the vibration problem.

The first tuned reed would be designed to vibrate at the rotational speed of the main rotor shaft. The second tuned reed would be designed to vibrate at twice the frequency or rotation of the main rotor shaft. The third tuned reed would be designed to vibrate at five times the frequency of rotation of the main rotor shaft which approximates the rotation of the tail rotor and tail rotor drive shaft.

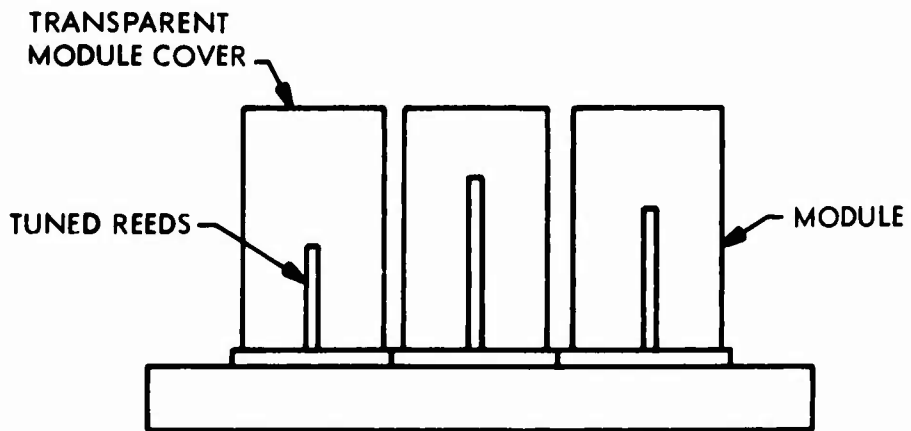
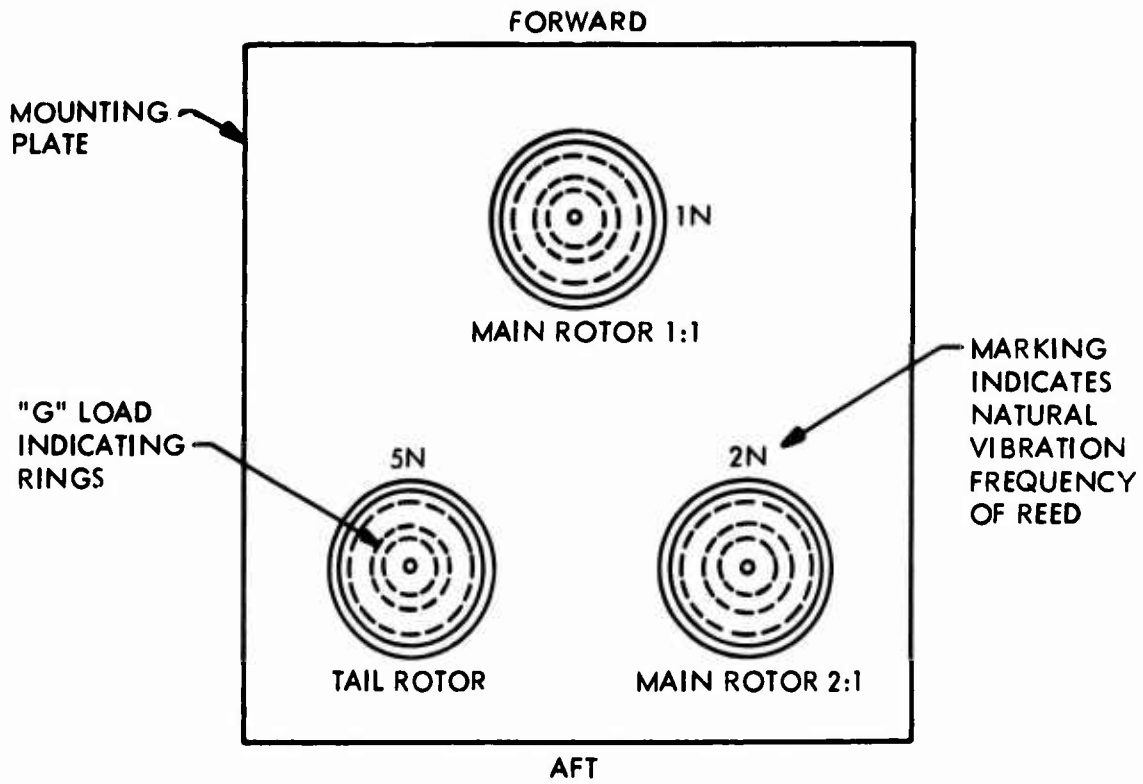

Figure 48. Reed Vibration Instrument.

The following examples (Figures 49 through 51) are indicative of the diagnostic capabilities of the proposed instrument.

Capabilities/Limitations: The conceptual reed vibration instrument would be designed to indicate vibrational peculiarities with the major drive components of a particular model helicopter. It is a small, portable instrument to be used by mechanics and inspectors to troubleshoot drive train problems. To increase its usable life, it is recommended that it be used only during maintenance periods. During equipment inspections and checkouts it can be secured to the cockpit floor or a vertical stiffener.

Skill/Training Requirements: Operation of the reed vibration instrument is simple as conceptually envisioned. However, interpretation of reed action will be difficult for problems other than the classical handbook variety. Therefore, some on-the-job training will be required.

#### DELAMINATIONS/DEBONDS

Bonded honeycomb structures are being used in a variety of applications in Army aircraft. Structures of this type are comprised of a honeycomb core to which face sheets are bonded with layers of adhesive to form a sandwich construction. The honeycomb core is usually aluminum, although nonmetallic materials such as fiberglass and Nomex are being introduced. Both metallic and nonmetallic skins (aluminum, titanium, fiberglass) are in current usage. Core and skin thickness vary considerably depending upon the application. Structures with variable cross sections are encountered in such applications as rotor blades.

Inspections of bonded honeycomb structures are performed to detect the presence of delaminations or debonds which can impair structural integrity. Typical of the flaws which can develop through manufacturing irregularities or service stress are bond voids, crushed core, adhesive-to-core separations and face sheet-to-adhesive separations.

The current inspection technique usually involves a visual examination for obvious surface indications of delamination or debond. This is often augmented by a requirement to tap a coin over the skin to detect sound variations indicative of voids or delaminations below the surface. The coin-tapping procedure

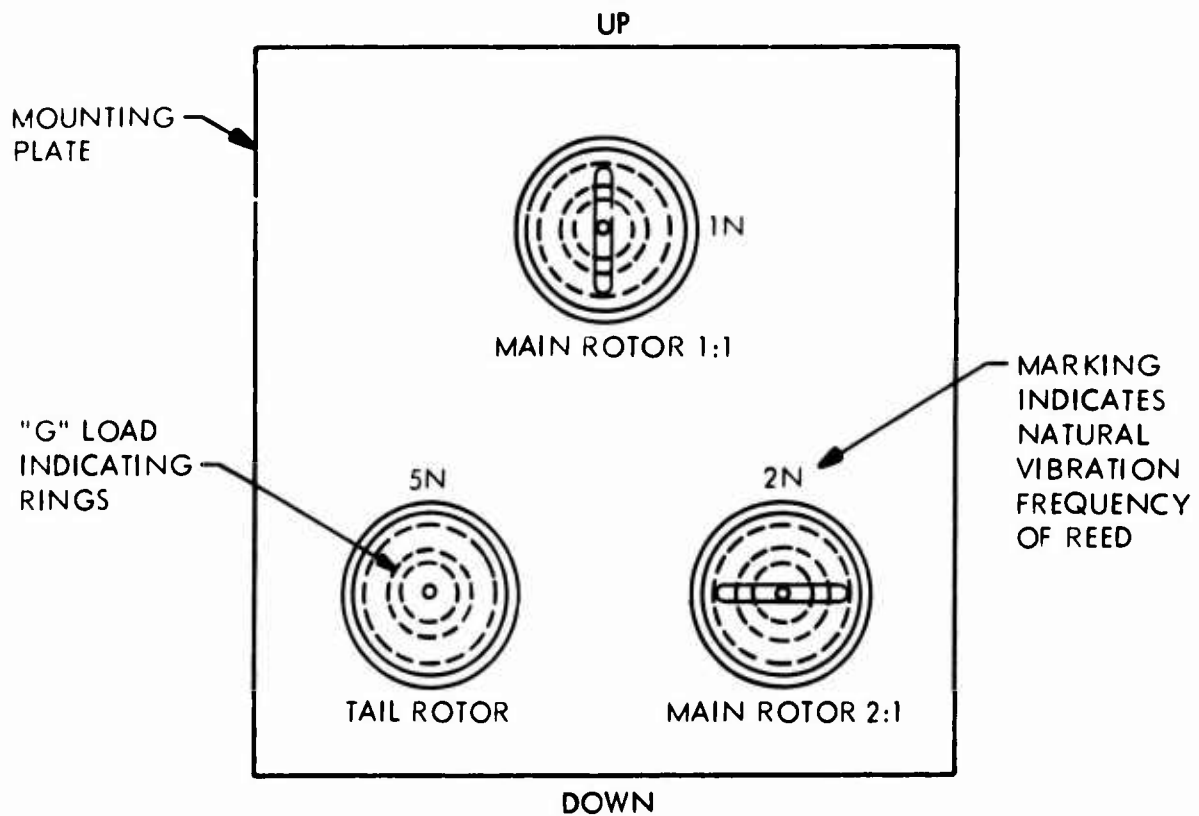

DIAGNOSIS: Excessive 1:1 Vertical and 2:1 Lateral - Main Rotor Blades out of track and sweep  
(Instrument Mounted Vertically)

Figure 49. Reed Instrument Diagnosis - Main Rotor.

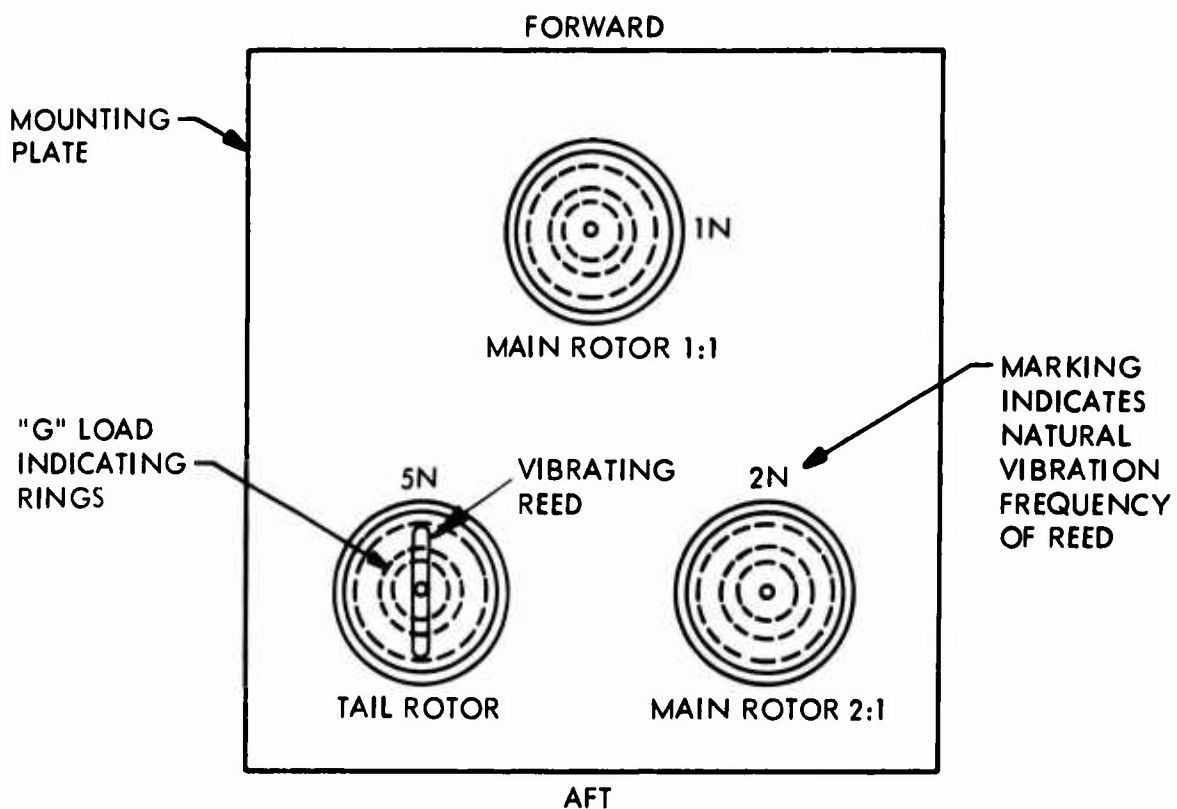

DIAGNOSIS: Tail Rotor Assembly not in balance. (Instrument Mounted Horizontally)

Figure 50. Reed Instrument Diagnosis - Tail Rotor.

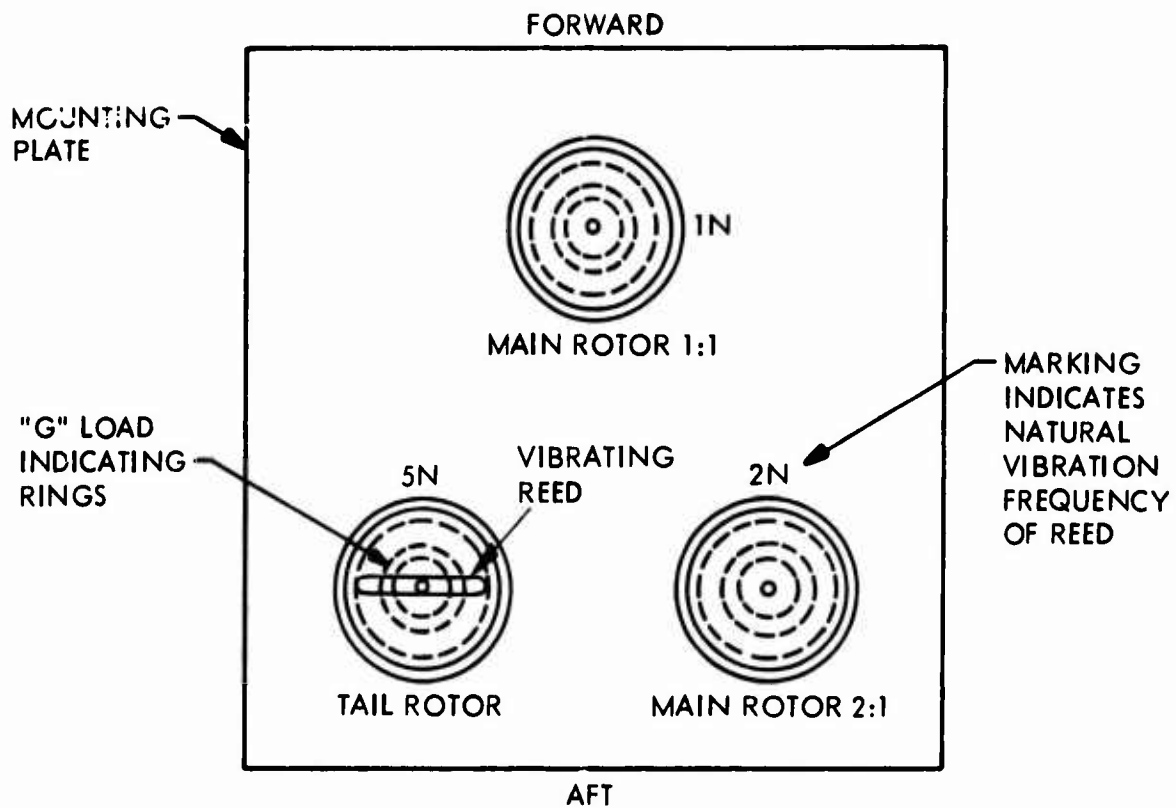

DIAGNOSIS: Tail Rotor Drive Shaft flexing or whipping.  
(Instrument Mounted Horizontally)

Figure 51. Reed Instrument Diagnosis - TR Drive Shaft.

requires an experienced inspector and involves a great deal of subjective judgement. When the inspector is able to discriminate between sounds emitted by coin-tapping, a delamination or debond very often has progressed to a serious state.

A method is needed to reduce the subjectivity involved in the inspection of bonded honeycomb structures for delaminations and debonds. Eddy-sonic and ultrasonic techniques offer two potential solutions.

#### Low Frequency Ultrasonic Tester

Devices operating in the lower range of the ultrasonic spectrum (20 to 500 KHz) are used to inspect for voids and delaminations in bonded structures. The operating principles of these low frequency devices are basically the same as the ultrasonic testers which operate in the "pitch-catch" or "pulse-echo" sending-receiving modes (see discussion on Ultrasonic Test Equipment). They are, however, somewhat less sensitive in this application and cannot determine flaw size as accurately as ultrasonic testers used for crack inspection for example. Alternatively, probe manipulation is less critical and inspection speed is generally greater.

Item Name: Sondicator

Manufacturer: Automation Industries, Incorporated, Sperry Division, Danbury, Connecticut 06810

Part/Model No.: S-2B

Figure No.: 52

Size: 12 in. x 8 in. x 9 in.

Weight: 13lb

Power Requirements: 10-hour rechargeable battery or AC 50/60 cycle

Cost: Approximately \$2700

Current Users: U.S. Air Force, Commercial

FSN: 6635-432-1540

MIL Spec: Unknown

Operating Environment: Ambient temperature 0°F to 150°F approximately.

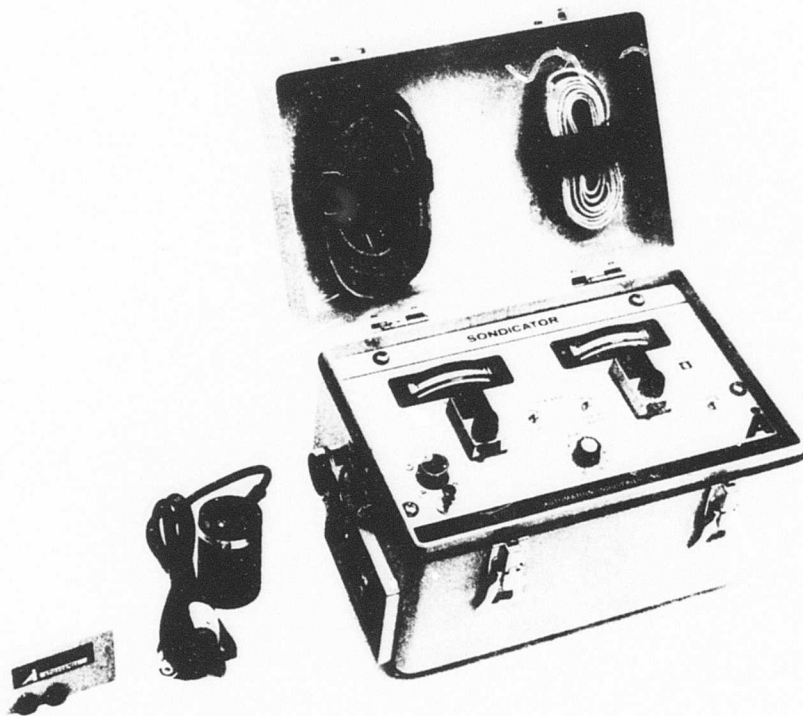

Figure 52. S-2B Sondicator.

Method of Operation: The S-2B Sondicator uses a transmitting sensor to apply repeated pulses of low frequency energy to the component being inspected. The energy propagated through the material is received by a similar sensor contained in the single probe assembly. The amplitude and/or phase displacement experienced by these propagated vibrations is measured continuously as the probe is scanned across the surface of the structure.

The Sondicator is initially calibrated using a test specimen of known quality. The surface to be inspected is cleaned to permit good contact with the probe while allowing free movement. The surface is inspected, using linear or circular, overlapping motion, while monitoring the amplitude and phase meters on the instrument panel. When a flaw causes a sound transmission variation equivalent to those to which the device is calibrated, an audible buzzer sounds and a light located on the probe

illuminates. The inspector marks the area of the defect and continues the examination.

Capabilities/Limitations: The S-2B Sondicator is a portable, solid state, low frequency ultrasonic nondestructive testing instrument operated by rechargeable batteries or line voltage. Designed to evaluate the integrity of bonded and composite materials, the instrument is suited to field inspection of structures for freeze damage, fatigue or adhesive failures. The Sondicator can operate with a wide variety of probes and sensors. These probes do not require fluid couplants to propagate sound energy from the search unit to the test piece. The probe supplied with the instrument can be used on both metallic and nonmetallic surfaces. The instrument will detect unbonded areas of at least 1/2 inch in diameter. Effective range for aluminum face sheet is 0.020 to 0.125 inch; composites to 1/2 inch thick; laminates totaling 0.125 inch, any bond line. Maximum scan speed at 20 Hz pulse repetition rate is 5 inches per second (1/4 inch resolution per pulse). Operating frequency is 20 KHz and pulse repetition rate is 20 Hz. The 10-hour battery is rechargeable.

Skill/Training: The S-2B Sondicator requires a somewhat lesser skill and experience level for the repetitive inspection tasks than other ultrasonic test devices which are used for detection of small, localized defects. Like these other devices, however, the Sondicator requires an initial setup to establish the accept/reject limits for a given component or structure and this initial calibration necessitates a skilled and experienced operator.

### Eddy-Sonic Inspection

Eddy-sonic is a nondestructive method of inspection used primarily for detection of voids and delaminations in bonded honeycomb structures of metal face and/or metal core construction. It is also used for inspection of bonded metal skins. Eddy-sonic operates on the principle that mechanical or sonic vibration induced in a test object by electromagnetic coupling with a transducer will produce sonic emissions indicative of flaws in the bonded joint. Excitation of the panel is induced by eddy currents. The sonic resonance or chatter characteristic of the test object is monitored by a special sensitive microphone. The signal level is displayed on a visual meter or

oscillograph trace and is usually combined with some type of visual or audible alarm.

Eddy-sonic applications include metals and nonconductors joined to metals, preferably of regular and uniform shape. In use, the inspection probe must accommodate the part and must be in close contact with the surface being inspected. Large surface areas can be inspected rather quickly. Flaw indications are coarse but generally reliable.

Item Name: Harmonic Bond Tester (Eddy-Sonic)

Manufacturer: Shurtronics Corporation, Santa Ana, California 92711

Part/Model No.: Mark IIB

Figure No.: 53

Size: 8 in. x 12 in. x 12 in.

Weight: 22 lb  
(with batteries)

Power Requirements: 120V/60 cycles or  
240V/50 cycles and  
12VDC internal battery

Cost: Approximately \$4500

Current Users: U.S. Air Force  
U.S. Navy  
Commercial Airlines

FSN: VX6635-148-9396  
VX6635-038-4312

MIL Spec: Unknown

Operating Environment: The instrument is mechanically designed to withstand moderate shock, vibration, and other extremes of environment associated with portability. Ambient temperatures range from 0°F to 150°F approximately.

Method of Operation: The Mark IIB operates by exciting pulsed, high frequency vibrations into bonded materials and structures so that the resulting acoustical response can be detected and used to distinguish a sound, reliable structure from a defective one.



Figure 53. Harmonic Bond Tester.

In a loosely bonded conductive material, or in the areas of "voids", these vibrations will cause an ultrasonic "rattle" with amplitude and phase characteristics that are dependent on the size and type of the defect. An ultrasensitive microphone in the probe detects this "rattle", which is then compared to an established threshold for determination of the acceptable quality level. Any irregularity that falls outside the selected level will trigger a red warning light, and at the operator's option, an audible alarm.

For use on nonmetallic structures, a direct-coupled probe is used to excite these high frequency vibrations. The pickup in this probe is also mechanically coupled to the structure.

Capabilities/Limitations: The Mark IIB is effective on the full range of today's structural materials--aluminum, titanium, boron graphite, stainless steels (both conductive and nonconductive), fiberglass, and graphite composites. All adhesively bonded structures, including honeycomb and fusion bonded materials, and resistance welded assemblies can be examined for voids, delamination and corrosion. No couplant between probe and structure is required. Curved as well as flat surfaces can be checked. Will "read" through painted surfaces. Scanning speed is relatively fast--up to 5 square feet per minute. The unit provides a reliable indication of the presence of a flaw, but given only a coarse indication of its size. The self-contained battery provides over 8 hours of continuous use before recharging. Charging time from completely discharged state is approximately 14 hours. Battery life is estimated at 500 charge-discharge cycles.

Skill/Training: The Mark IIB requires a trained operator for initial calibration and setup. For routine inspection, sufficient experience is needed to differentiate between real defects and false indications produced by surface discontinuities, improper probe positioning, etc. This skill can be acquired generally without formal training.

### LEAKAGE

The time required to inspect aircraft for leaks in the fuel, oil and hydraulic systems varies considerably depending upon the complexity of these systems in the aircraft. For the small, light aircraft, fluid systems are relatively simple while larger aircraft tend toward substantial complexity. The principal

methods of inspecting fluid systems for leakage are visual examination and fluid level checks. In most cases, these inspections are effective in determining the presence of external system leaks. The problems associated with inspection for leakage are involved mainly with isolating source of leakage, whether internal or external.

### External Leakage

Inspection for localized leaks in fuel, oil and hydraulic systems requires pressurization of the system and a visual inspection of lines, hoses, connections and components. In areas of limited access or areas where many lines and components are present, especially if the size of the leak is small and escaping fluid is distributed over a wide area, locating the source may be difficult and time-consuming. The inspection often involves a laborious, step-by-step process of wiping and examining components until the leak is isolated. Two techniques which may facilitate the inspection are the use of dye penetrants and the application of liquid sensitive tape or coatings in areas where leaks frequently develop.

### Internal Leakage

Internal system leakage in fluid and pneumatic supply and transfer components such as valves, actuators, regulators, etc., in the fuel, oil and hydraulic systems of the aircraft normally develops at seals and valve seats through routine wear or fluid contamination. Internal leaks are often evidenced by a loss of system operating pressure or a degradation in system performance such as slow actuation, poor response, etc.

Detecting internal system leaks usually involves a step-by-step procedure of blocking off each hydraulic section, opening lines to check leak rates and replacing suspected components. Although tests of this type are usually effective in locating faulty components, they are extremely time consuming. A troubleshooting check of this type would be required at the scheduled inspection interval if routine functional tests indicated the presence of internal system leakage.

An alternative method of detecting internal system leaks which reduces inspection time substantially uses the ultrasonic noise generated by an internally leaking valve as the test criterion.

Leak Indicating Tape

The typical leak indicating tape is composed of thin metal foil (usually aluminum) bonded to thin asbestos paper with a coloring material dispersed between. On contact with hydrocarbons and other organic liquids, the white asbestos is stained red. The red stain remains after all liquid has evaporated, thus giving permanent record even of a pressure leak which occurs only during operation.

Two types of tape are currently being marketed, those with perforated foil and those with nonperforated foil. The perforated type permits passage of leaking fluids through the foil and thus allows installation with the asbestos paper out-board. This greatly facilitates subsequent visual checks for tell-tale red stains. The perforated type, when installed as described, has the added advantage of shielding the asbestos paper from residual surface contamination which may give false leak indications. The nonperforated tape must be installed with the asbestos toward the line or fitting being monitored, and therefore is more difficult to check for stains. This type is used in areas subject to spray or splash from sources other than that being checked.

Application of either type of tape is simple and involves only the task of cutting to size and crimping around the suspect line or fitting using finger pressure. If additional restraint is necessary, for instance on large flat areas or where test conditions include strong vibrations or wind, adhesive tape may be used.

Item Name: Jet-Tec Leak Indicating Tape

Manufacturer: American Gas and Chemicals, Incorporated, New York, New York 10021

Part/Model No.: JET-TEC Type A  
JET-TEC Type B

Figure No.: None

Size: Strip 2.5 in. x 4 ft.

Weight: Negligible

Power Requirement: Not Applicable

Cost: Approximately \$2.00 per strip

Current Users: U.S. Air Force  
Commercial Airlines

FSN: 4940-954-6516

MIL Spec: Unknown

Operating Environment: The tape is composed of thin metal foil bonded to thin asbestos paper with red coloring material dispersed between. The organic matter chars and blackens the tape at excessive temperatures, but the foil and asbestos cannot burn. The tape can be applied to fuel lines close to the hot section of engines.

Method of Operation: Jet-Tec tape is foil backed; therefore, it can easily be crimp-fitted around line connections or other fittings by applying hand pressure. Special heat and cold resistant adhesive tape is also supplied for fastening the Jet-Tec tape more securely on flat surfaces or when test conditions include strong vibrations or high velocity wind streams. Two types of Jet-Tec tape are available. Type A has the foil perforated so that fuel or oil can penetrate, thereby allowing the asbestos side to be exposed for easy visibility. Placing the foil side towards the line fitting has the additional advantage of protecting the asbestos paper from surface contamination. In those cases where oil or fuel spray from another source might interfere, Type B with unperforated foil is used. Type B is wrapped with the asbestos side inward. On contact with hydrocarbons and other organic liquids, the white asbestos paper of either type tape stains red. The red stain remains after the liquid has evaporated. When Type B tape is used, obviously it must be removed for inspection.

Capabilities/Limitations: Jet-Tec tape is capable of detecting minute leaks of engine fuels, hydraulic fluids, oils, and organic solvents. Sensitivity is such that leakage of only 0.05 cc is detectable. It is possible to identify the type of fluid which has leaked by the color of the stain on the white asbestos paper. JP-4 turns the paper pink, hydraulic fluid turns it red, and jet engine oil dark red. The tape is non-toxic, will not stain the part being monitored, and does not promote corrosion.

Skill/Training Requirements: Skill and training requirements are minimal.

## Leak Detecting Paint

Leak detecting paints are specially formulated to react by color change when contacted by fluids such as lubricating oil, fuel, or hydraulic fluid. The color change is usually from white to red in the affected area. This provides good contrast and eases subsequent visual checks.

To be effective, the paint must be applied to an area which has been cleaned of all residual oil or grease. Application is usually by brushing, and drying time is normally no more than 30 minutes. The color change which occurs as previously described is irreversible even if the leaked liquid evaporates.

One characteristic of leak detecting paint is that it also reacts to external sources of fluids such as splash or spray. This could be a serious disadvantage in some applications. Another undesirable aspect of its use is that much cleanup must be accomplished after the inspection.

Item Name: Leak Detecting Paint

Manufacturer: American Gas and Chemicals, Incorporated  
New York, New York 10021

Part/Model No.: ODP-110

Figure No.: None

Size: 4 ounce bottle

Weight: several ounces

Power Requirements: Not Applicable

Cost: Approximately \$2.00 per bottle

Current Users: Commercial companies

FSN: None

MIL Spec: None

Operating Environment: Suitable for use at temperatures up to 300°F.

Method of Operation: The test area must be cleaned to remove all oil or grease. The paint is stirred and applied to test area with a brush. Drying time is normally about 30 minutes.

but can be accelerated with a drying lamp or fan. The white paint (water base) will develop a red stain when contacted by oil, hydraulic fluid, or liquid fuels. The color change is irreversible even if the oil or fuel evaporates.

Capabilities/Limitations: ODP-110 paint is used to locate fluid leaks in locations not directly observable during aircraft operation, or where suspected leaks are too small to be self-evident. Its sensitivity is such that a very small oil droplet or very thin oil film will be indicated by a change in paint color from white to red. The color change is irreversible. The inspection area should be cleaned after each test use.

Skill/Training Requirements: Skill and training requirements are minimal.

#### Leak Indicating Powder

Leak indicating powders react to contact by oils, fuels, etc. in the same manner as do leak indicating paints previously described--namely, the powder changes color (usually white to red).

As with paints, powders must be applied only to areas which have been cleaned of all residual grease or oil. Most manufacturers supply powder in aerosol cans to simplify its application. The powder is suspended in a liquid vehicle which evaporates rapidly upon application. Once stained by contact with a leaked liquid, the stain remains even if the liquid subsequently evaporates.

Again, as with paints, leak detecting powders react to external sources of fluids such as splash or spray; this could be a disadvantage in some applications. Powder is somewhat easier to remove from the test article during post-inspection cleanup than is paint.

Item Name: Oil Detecting Powder

Manufacturer: American Gas and Chemicals, Incorporated, New York, New York 10021

Part/Model No.: Bug-It ODP

Figure No.: 54

Size: 12 oz. Aerosol Can

Weight: Approximately  
1 lb

Power Requirements: Not Applicable

Cost: Approximately \$3.00 per can

Current Users: Commercial companies

FSN: None

MIL Spec: None

Operating Environment: Suitable for use at temperatures up to 300°F.

Method of Operation: The test area must be cleaned to remove all oil or grease. The aerosol can is shaken well and then sprayed onto the suspected leak area. The liquid vehicle dries almost immediately leaving a white powder surface coating. A clearly visible stain appears when the powder comes in contact with oil, fuel, or hydraulic fluid.

Capabilities/Limitations: Bug-It ODP Powder is used to locate oil, hydraulic, or fuel leaks in locations not observable during aircraft operation, or where suspected leaks are too small to be self-evident. The color change that occurs when any of the above liquids contact the powder is irreversible. The inspected area should be cleaned after test use.

Skill/Training Requirements: Skill and training requirements are minimal.

#### Leak Indicating Pads

Leak indicating pads are available in several sizes and made from different materials. A typical pad, however, is simply a foam disc 1-1/2 inches in diameter and approximately 1/2 inch thick. Both flat surfaces are coated with an oil sensitive paint.

In use, the pad is wiped lightly over a suspect area. If oil, fuel or hydraulic fluid is present even as a thin film, the pad will develop a red stain. The time required for development is usually from 30 to 60 seconds.



Figure 54. Oil Detecting Powder (Aerosol Can).

The big advantage that pads have over paints or powders is that no post-inspection cleanup is required. As with these other oil detectors, however, pads make no distinction between liquids leaked from within the test object and liquids sprayed or splashed on the test object from an external source. This can be a severe disadvantage in some applications.

Unlike tapes, paints and powders which can be applied and remain on a test article for long periods of time for continual monitoring, pads are used on a one-shot, real-time basis when checking for leaks.

Item Name: Oil Sensitive Pads

Manufacturer: American Gas and Chemicals, Incorporated, New York, New York 10021

Part/Model No.: ODP-110 Pads

Figure No.: None

Size: 1.5 in. diameter x 0.5 in. thick

Weight: Negligible

Power Requirements: Not Applicable

Cost: Approximately \$9.00 per 100 pads (lower unit cost in larger quantities)

Current Users: Commercial companies

FSN: None

MIL Spec: None

Operating Environment: Temperature of test area limited to operator's tolerance. Pads are suitable for use at temperatures up to 300°F.

Method of operation: A pad is wiped lightly over the surface where a thin film of oil, hydraulic fluid, or fuel is suspected. If either of these liquids is present, the pad will develop a red stain within 30 to 60 seconds. Each pad has two oil detecting surfaces (two tests).

Capabilities/Limitations: The ODP-110 Pads are foam discs coated on both sides with oil sensitive ODP-110 paint. The sensitivity of the paint is such that a very small droplet of oil or very thin oil film will be indicated by a color change from white to red. The color change is irreversible. Using wipe pads instead of applying paint directly to the inspection article has the advantage of eliminating the need for post-inspection cleanup of paint. Pads are not effective on parts subject to splash or spray from external sources.

Skill/Training Requirements: Skill and training requirements are minimal.

### Fluorescent Tracer Additives

As the name implies, a tracer is a material which permits the detection, in trace quantities, of the presence of a substance, such as a liquid which has been "tagged" with the tracer. The tracer is simply one ingredient in the compound. Tracers may take a variety of forms, as for example radioactive indicators, pH indicators, flame test indicators, visible color dyes, or fluorescent dyes. This discussion is concerned with fluorescent tracers.

The principles underlying the usage of fluorescent tracers are basically the same as are found in the usage of fluorescent inspection penetrants, with perhaps some slight variations due

to the fact that some tracer usages involve materials which dry to solid form.

A fluorescent tracer consists of two parts, or two different kinds of dyes. One part, known as the "sensitizer" component, provides a desired level of dimensional sensitivity. Since most sensitizers yield a blue or bluish white fluorescence, a second part known as a "color former" component is often included to shift the fluorescent color from blue to a bright green, yellow, or red, as desired.

Color former dyes, used alone, usually do not provide usable levels of dimensional sensitivity. This means that solutions of color former dyes, even when employed in relatively high concentrations, fail to yield fluorescence response when the dye solution is applied in relatively thin films.

In many tracer applications, liquids are tagged with appropriate sensitizers at concentrations in the range of 2 to 10 grams per pint, although where high levels of dimensional sensitivity are required, the sensitizer may be employed at concentrations in excess of 15 grams per pint.

Microscopic liquid leaks in fuel tanks, pipelines, flotation systems for gyro compass apparatus, and various pressurized containers can be detected by use of suitable tracers which are selected according to their compatibility with the liquid material which is contained in the system.

The brightness response of a fluorescence-tagged material depends on the fluorescence efficiency of the tracer and the level of ultraviolet illumination on the fluorescent trace. With typical fluorescent tracers, and under conditions where a black light lamp can be operated fairly close to the inspection area, it is not difficult to obtain fluorescent brightness levels in the range of 50 footlamberts.

As a rule-of-thumb, it can be said that good seeability of a tracer indication will be obtained if the background brightness level is less than the tracer brightness by a factor of ten or more. In other words, the inspection area should have a subdued level of ambient illumination, below about five foot-candles, for average inspection conditions. In cases where the tracer brightness is reduced for any reason, a corresponding reduction in the ambient illumination is called for. Alterna-

tively, the tracer brightness can be increased by increasing the level of black light illumination.

Item Name: Fluorescent Tracer Additive

Manufacturer: Shannon Luminous Materials Company, Los Angeles, California 90046

Part/Model No.: T-100 Series

Figure No.: None

Size: Gallon Can

Weight: 7 lb

Power Requirements: Use of fluorescent tracers requires use of ultraviolet light source (black light). Power requirements for these items are presented in the section of this report which discusses black light lamps.

Cost: Approximately \$60.00 per gallon

Current Users: U.S. Air Force  
Commercial Companies

FSN: Unknown

MIL Spec: Unknown

Operating Environment: Tracer additives are introduced directly into the liquid stored in the system suspected of leaking. Additives have been developed which are compatible with oil, fuel, and hydraulic fluid.

Method of Operation: Tracer additives are supplied in highly concentrated form. They are mixed with the liquid contained in the system suspected of leaking. Recommended dilution ratio is 200 to 1. In some cases, a tracer may be diluted 500 to 1 and still provide satisfactory results.

The system or container to be inspected is filled with the properly diluted tracer and is pressurized if required. After an appropriate standby period, which may range from a few minutes to a few hours, the area of potential leaks is examined using a black light lamp to illuminate the area. Even an extremely minute leak will show as a bright fluorescent indication. Shannon Luminous offers tracer additives in two colors: blue/blue-white and green.

Capabilities/Limitations: The sensitivity of tracer additives is such that detection of microscopic leaks in liquid containers is possible. Visual and physical access to the suspected leak area is required. Two different colors are available. This is useful when attempting to isolate a source of trouble where more than one liquid phase is present.

Skill/Training Requirements: Skill and training requirements are minimal.

## CORROSION

The problems associated with inspection of Army aircraft for corrosion are obviously influenced greatly by the environment in which the aircraft operate. Those operating in arid climates experience little problem while those in proximity to salt water sustain significant corrosion damage. The inspection time involved varies accordingly. There are three major types of corrosion for which aircraft are inspected:

1. Pitting or surface corrosion
2. Galvanic corrosion
3. Exfoliation corrosion

### Pitting or Surface Corrosion

Visual inspection is usually specified for pitting or surface corrosion, commonly found on aluminum, steel or magnesium alloy parts. It is evidenced by a white or gray powdery deposit on the surface of the part.

Visual inspection to determine the presence and areas of corrosion is usually adequate, but sometimes the inspection areas are obscured by structural members, equipment installations or for other reasons and are awkward to check visually. Mirrors, borescopes or similar devices may be required in such areas. Magnifying glasses are useful for determining whether all corrosion products have been removed after the cleanup operation. Fluorescent oil may be useful for inspection of pitting or surface corrosion in certain specialized applications.

### Galvanic Corrosion

Galvanic corrosion or corrosion that occurs where dissimilar metals are in contact is recognizable by the presence of a

corrosion buildup at the joints or mating surfaces between the metals. The electrical potential difference between the metals in the presence of an electrolyte (condensation from a salt-air atmosphere) establishes an electrochemical cell and corrosion occurs.

Magnesium and aluminum skins riveted together or aluminum hinges with steel pins are examples of items susceptible to this type of corrosion. A strictly visual inspection for this type of corrosion is generally inadequate. When the corrosion is visible at the joints or mating surface, considerable damage has already been done.

Ultrasonics and X-ray are two methods for detection of corrosion between the mating surfaces of metal parts.

### Exfoliation Corrosion

Exfoliation corrosion is a severely destructive form of corrosion characterized by the actual leafing-out of corroded sections of metal away from the rest of the part. This type of corrosion usually starts on the surface of the part around rivet holes and progresses under the surface of the metal where it attacks the boundaries of ferrous and nonferrous metal grain. The corrosive attack on the grain boundary material produces corrosion products which take up more volume than that originally occupied by the unaffected grain boundaries, causing the part to swell. Exfoliation corrosion is found most often on extruded parts because the forming process elongates the grains of the metal.

Visual inspection, the method commonly used for this type of corrosion, is generally inadequate. By the time the corrosion is detected visually, the intergranular attack is so advanced that the static strength of the part is impaired due to the reduction of its effective cross-sectional area. Some more effective inspection methods that might be considered include eddy current, ultrasonics, and X-ray.

### Fluorescent Oil Method of Corrosion Detection

Fluorescent oil used for corrosion detection is a water-miscible compound basically similar to the fluorescent oil used for penetrant inspection. The main differences are: corrosion

detecting oil has a lower level of detergent quality; and the washability properties are only sufficiently high enough to permit rinsing from smooth, chemically clean, nonporous metal surfaces.

The oil will cling to a soiled spot on an otherwise clean, insoluble surface and it will cling to a blemish, such as corrosion, on an otherwise smooth surface.

The inspection process involves chemically cleaning and thoroughly drying the area to be inspected. Fluorescent oil is then applied either by spraying, flowing, brushing, or dipping. The oil is allowed to penetrate for at least 5 minutes and is then rinsed away preferably using an aerated water spray. Following the rinse, the surface is dried by natural evaporation, with or without the aid of warm, gentle air currents.

After drying and before a developer is applied, the more severe corrosion spots will be exposed as glowing marks under black light illumination. Less severe blemishes will normally require the application of a thin coat of nonaqueous developer before they will be revealed.

Item Name: Fluorescent Oil

Manufacturer: Sherwin Incorporated, Los Angeles, California 90022

Part/Model No.: HM400-PLUS

Figure No.: None

Size: Pint Can

Weight: 1 lb

Power Requirement: All fluorescent oil inspection systems require use of a long wave ultraviolet light source (black light). Power requirements for these items are presented in the section of this report which discusses black light lamps.

Cost: Approximately \$4.00 per pint can

Current Users: U.S. Air Force  
Aircraft Manufacturers

FSN: Unknown

MIL Spec: MIL-I-8963  
MIL-I-  
25135C

Operating Environment: Recommended temperature for parts being inspected is between 60°F and 90°F. Flash point of HM400-Plus is over 200°F.

Method of Operation: The area to be inspected must be cleaned chemically and dried thoroughly. HM400-Plus is applied by spraying, flowing, brushing or dipping. The HM-400-Plus is allowed to remain on the surface for 5 minutes or longer to allow penetration of corrosion. Excess penetrant is then flushed off with water spray. Following the rinse, the surface is dried by natural evaporation, with or without aid from warm, gentle air currents. After drying, the more severe corrosion spots will be exposed as glowing marks under black light. Less severe blemishes will require the application of a thin coat of non-aqueous developer before they will be revealed.

Capabilities/Limitations: HM400-Plus reveals areas where corrosion is present but not obvious visually. It can also be used to determine if all traces of corrosion have been removed after cleanup (rework). HM400-Plus is usable on any type of metal but requires an ultraviolet light source and is somewhat messy to use.

Skill/Training Requirements: The fluorescent oil method of corrosion inspection is a demanding process which is best accomplished by a skilled and experienced inspector. The reliability of the inspection is directly proportional to the expertise of inspecting personnel assigned to the task. False indications are possible if the cleaning process was inadequate (HM400-Plus will cling to soiled spots). On the other hand, true areas of corrosion may not be revealed because of excessive flushing of the penetrant prior to black light illumination. Little formal classroom instruction is necessary, but much on-the-job training is desirable to develop skill and experience.

## CONCLUSIONS AND RECOMMENDATIONS

This report represents a combined survey and design effort of locating inspection aids which will provide a more effective inspection on today's and future Army helicopters. Conceptual design efforts were made in areas where off-the-shelf inspection aids do not provide an adequate solution. The most promising conceptual aids are:

1. Bearing Wear Pin
2. Indicator Label
3. Diagnostic Reed Vibration Instrument

These aids are recommended for engineering development. In addition to these aids, several aids ranked highly in the cost and inspection effectiveness evaluations:

1. Optical Comparitor
2. Leak Indicating Tape
3. Temperature Indicating Tabs
4. Optical Indicating System for Bolt Torque

These aids are simple, low-cost solutions to inspection problems. All of the inspection aids presented in this report are applicable to the aircraft inspection problems presented. One of them may be more suitable than another for a specific aircraft application.

## SELECTED BIBLIOGRAPHY

1. Gardner, Gerald C., NONDESTRUCTIVE TESTING, Southwest Research Institute; NASA Technical Report SP-5113, Technology Utilization Office, National Aeronautics and Space Administration, Washington, D. C., 1973.
2. Vary, Alex, NONDESTRUCTIVE EVALUATION TECHNIQUE GUIDE, Lewis Research Center; NASA Technical Report SP-3079, Scientific and Technical Information Office, National Aeronautics and Space Administration, Washington, D. C., 1973.
3. Neuschaefer, Robert W. and Beal, James B., ASSESSMENT OF AND STANDARDIZATION FOR QUANTITATIVE NONDESTRUCTIVE TESTING, Applied Technology Branch, Analytical Operation Division, Quality and Reliability Laboratory, NASA Technical Memorandum TMX-64706, National Aeronautics and Space Administration, Washington, D. C., 30 September 1972.
4. Kranska, I. R., and Prusinski, R. G., EVALUATION OF COMMERCIALLY AVAILABLE EDDY CURRENT EQUIPMENT, General American Research Division; Air Force Materials Laboratory Technical Report AFML-TR-69-221, Air Force Systems Command, Wright-Patterson Air Force Base, Ohio, May 1970.
5. Kranska, I. R., and Kamm, H. W., EDDY CURRENT INSPECTION OF TURBINE BLADES, General American Research Division; Air Force Materials Laboratory Technical Report AFML-TR-70-266, Air Force Systems Command, Wright-Patterson Air Force Base, Ohio, October 1971.
6. Kranska, I. R., and Kamm, H. W., EVALUATION OF SONIC METHODS FOR INSPECTING ADHESIVE BONDED HONEYCOMB STRUCTURES, General American Research Division; Air Force Materials Laboratory Technical Report AFML-TR-69-283, Air Force Systems Command, Wright-Patterson Air Force Base, Ohio, August 1970.
7. Kamm, H. W., and Kranska, I. R., A REVIEW OF NONDESTRUCTIVE METHODS FOR THE DETECTION OF CONCEALED CRACKS, General American Research Division; Air Force Materials Laboratory Technical Report AFML-TR-71-120, Air Force Systems Command, Wright-Patterson Air Force Base, Ohio, July 1971.

8. Siegmund, Walter P., FIBER OPTICS, PRINCIPLES, PROPERTIES AND DESIGN CONSIDERATIONS, American Optical Corporation, Fiber Optics Division, Southbridge, Mass., November 1970.
9. THE ULTRASONIC DETECTION HANDBOOK, Instruction Manual DC-201, Hewlett Packard, Delcon Division, Mountain View, California, 1968.
10. AEROSPACE NONDESTRUCTIVE INSPECTION (NDI) AND SPECTROMETRIC OIL ANALYSIS PROGRAM (SOAP), Equipment Maintenance, U. S. Air Force, Tactical Air Command Manual TACM 66-1, 1 June 1973.
11. NONDESTRUCTIVE INSPECTION METHODS, U. S. Air Force Technical Manual, T.O. 33B-1-1, 1 February 1966, revised 1 June 1971.
12. NONDESTRUCTIVE INSPECTION, USAF SERIES UH-IN HELICOPTER, U. S. Air Force Technical Manual, T.O. IH-1(U)N-36, 1 October 1973.
13. EDDY CURRENT TEST SET, MODEL NO. ED-500, INSTRUCTIONS AND PARTS BREAKDOWN, U. S. Air Force Technical Manual, T.O. 33B2-7-1, 15 July 1967.
14. ULTRASONIC LEAK DETECTOR, TYPE A/E24T-56, A/E24T-55, OPERATION AND MAINTENANCE, U. S. Air Force Technical Manual, T.O. 33D9-84-30-1, 15 September 1964, revised 15 March 1965.
15. CORROSION PREVENTION AND CONTROL FOR AEROSPACE EQUIPMENT, U. S. Air Force Technical Manual, T.O. 1-1-2, 1 January 1973, revised 5 April 1973.
16. HELICOPTER INSPECTION AIDS AND TECHNIQUES, Volume I & II, Computer Search 203-1246, Western Research Application Center, University of Southern California, Los Angeles, California, September 1973.