

UNCLASSIFIED

AD NUMBER

AD800083

LIMITATION CHANGES

TO:

Approved for public release; distribution is unlimited.

FROM:

Distribution authorized to U.S. Gov't. agencies and their contractors;
Administrative/Operational Use; OCT 1966. Other requests shall be referred to National Aeronautical Space Administration, Arnold AFB, TN.

AUTHORITY

AE DC, USAF ltr, 4 Apr 1973

THIS PAGE IS UNCLASSIFIED

AEDC-TR-66-170

cy!

**ARCHIVE COPY
DO NOT LOAN**

**THERMAL AND DYNAMIC INVESTIGATION OF THE
HUGHES ATS SPACECRAFT AND APOGEE MOTOR SYSTEM
AT SIMULATED HIGH ALTITUDE
(S/S SYNCHRONOUS SPACECRAFT THERMAL MODEL S/N T-4)**

**A. F. Domal
ARO, Inc.**

October 1966

This document has been approved for public release
its distribution is unlimited. *Per A. J. Letter
dated April 73
Signed by William
O. Cole*

This document is subject to special export controls
and each transmittal to foreign governments or foreign
nationals may be made only with prior approval of
NASA, Goddard Space Flight Center.

**LARGE ROCKET FACILITY
ARNOLD ENGINEERING DEVELOPMENT CENTER
AIR FORCE SYSTEMS COMMAND
ARNOLD AIR FORCE STATION, TENNESSEE**

PROPERTY OF U. S. AIR FORCE
AF 40(600)1200

AEDC-7966-



AEDC TECHNICAL LIBRARY



025E TE000 0210 5

NOTICES

When U. S. Government drawings specifications, or other data are used for any purpose other than a definitely related Government procurement operation, the Government thereby incurs no responsibility nor any obligation whatsoever, and the fact that the Government may have formulated, furnished, or in any way supplied the said drawings, specifications, or other data, is not to be regarded by implication or otherwise, or in any manner licensing the holder or any other person or corporation, or conveying any rights or permission to manufacture, use, or sell any patented invention that may in any way be related thereto.

Qualified users may obtain copies of this report from the Defense Documentation Center.

References to named commercial products in this report are not to be considered in any sense as an endorsement of the product by the United States Air Force or the Government.

THERMAL AND DYNAMIC INVESTIGATION OF THE
HUGHES ATS SPACECRAFT AND APOGEE MOTOR SYSTEM
AT SIMULATED HIGH ALTITUDE
(S/S SYNCHRONOUS SPACECRAFT THERMAL MODEL S/N T-4)

A. F. Domal

ARO, Inc.

This document has been approved for public release
its distribution is unlimited.

*Per A.F. Letter
dated 4 April 73.
Signed by William
O. Cole*

This document is subject to special export controls
and each transmittal to foreign governments or foreign
nationals may be made only with prior approval of
NASA, Goddard Space Flight Center.

FOREWORD

The test program reported herein was sponsored by the National Aeronautics and Space Administration (NASA), Goddard Space Flight Center (GSFC), Greenbelt, Maryland, under Air Force Systems Command (AFSC), System 920E, Project 0393. Technical liaison was provided by Hughes Aircraft Company (HAC). The structural model of the Applications Technology Satellite (ATS) spacecraft was constructed and instrumented by HAC. The Jet Propulsion Laboratory (JPL) SR-28-3 solid-propellant, apogee rocket motor was manufactured by JPL.

Testing was conducted by ARO, Inc. (a subsidiary of Sverdrup & Parcel and Associates, Inc.) in Propulsion Engine Test Cell (J-5) of the Large Rocket Facility (LRF), Arnold Engineering Development Center (AEDC), AFSC, Arnold Air Force Station, Tennessee, under Contract AF40(600)-1200. The results reported herein were obtained on June 2, 1966 under ARO Project No. KB1603, and the manuscript was submitted for publication on August 5, 1966.

This technical report has been reviewed and is approved.

John W. Hitchcock
Major, USAF
AF Representative, RTF
Directorate of Test

Leonard T. Glaser
Colonel, USAF
Director of Test

ABSTRACT

A NASA/Hughes Aircraft Company, Applications Technology Satellite (ATS) spacecraft, modified for captive testing, was used in an investigation at near vacuum conditions to determine if various spacecraft components would overheat following operation of the apogee "kick" motor. The apogee motor system, a Jet Propulsion Laboratory solid-propellant rocket motor (S/N SR-28-3), was installed in ATS spacecraft (S/N T-4) and fired in a "soft stand" (nonspinning) which isolated the motor/spacecraft thermally and dynamically. The motor was ignited and operated at a pressure simulated altitude of 110,000 ft. The thermal data were recorded for 3600 sec after ignition at an average altitude of 125,000 ft. The highest temperature recorded was 935°F and was sensed on the apogee motor nozzle. The highest temperature recorded on the spacecraft was approximately 400°F and was sensed on the thermal barrier at 250 sec after apogee motor ignition. The highest spacecraft structural temperature was approximately 240°F, which was sensed 750 sec after apogee motor ignition. The spacecraft electronic component temperatures did not exceed 150°F throughout the entire 3600-sec heat soak period. The vibration data analysis indicated that the motor operation was relatively smooth, and no large power spectral density levels were found.

CONTENTS

	<u>Page</u>
ABSTRACT	iii
I. INTRODUCTION	1
II. APPARATUS	2
III. PROCEDURE	6
IV. RESULTS AND DISCUSSION	7
V. SUMMARY OF RESULTS.	10
REFERENCES.	11

ILLUSTRATIONS

Figure

1. ATS Flightweight Spacecraft	13
2. ATS Apogee Motor	16
3. S/A Igniter Assembly	18
4. Soft Stand Assembly	20
5. Isometric Schematic of Test Cell and Installation	22
6. Spacecraft Thermocouple Locations	23
7. Motor Case Thermocouple and Strain-Gage Locations	29
8. Accelerometer Locations.	30
9. Motor/Spacecraft Assembly Operations	32
10. ATS Installation in Test Cell	33
11. Temperature Data.	35
12. Power Spectral Density	59
13. Motor Case Strain and Test Cell Pressure Plots	60
14. Post-Firing View of ATS with Thermal Barrier Removed	61
15. Interior of Apogee Motor with Nozzle Removed	62
16. Nozzle Post-Firing Condition.	63

<u>Figure</u>		<u>Page</u>
17.	Post-Firing Head-On View of ATS with Thermal Barrier Removed	64
18.	Solar Panel Comparison	65

TABLES

I.	Physical Characteristics of the ATS Apogee Motor	67
II.	Summary of Instrumentation	68

SECTION I INTRODUCTION

The Applications Technology Satellite (ATS) provides a relatively large, adaptable, payload capability designed to achieve long life in circular, medium-altitude orbits (S/G version) or in a circular, synchronous, equatorial orbit (S/S version). The ATS S/S spacecraft is a spin-stabilized vehicle incorporating telemetry, propulsion, and orientation control elements (Ref. 1).

The ATS S/S version was tested at LRF-AEDC and was equipped with a Jet Propulsion Laboratory (JPL) solid-propellant rocket motor (apogee motor), which will provide the necessary velocity increment to the flight spacecraft, at the apogee of the transfer ellipse, to achieve a circular, synchronous, equatorial orbit. The basic apogee motor system requirement is to deliver sufficient total impulse at such a thrust level as to impart a nominal 6100-ft/sec velocity increment to the spacecraft at less than 9-g acceleration (Ref. 1). Once this is accomplished, the retained (hot) spent apogee motor must not create a thermal environment which will cause the spacecraft active electronic components to exceed operating temperature limits.

The ATS development and launch program provides for the fabrication of basic spacecraft and system test equipment using the techniques and subsystems developed under the Advanced Technological Development Program (NAS 5-2797). The program includes vehicle and subsystem developmental design verification testing and acceptance testing of each flight vehicle (Ref. 1).

As a part of this acceptance testing, a structural model of the ATS-S/S configuration, with a normal complement of electronic packages replaced by dummy units of comparable thermal characteristics, was tested at LRF-AEDC at pressure simulated altitude to determine the thermal environment and motor-induced vibration that the spacecraft will experience during ignition and burning of the apogee motor. The thermal investigation required definition of the post-ignition temperature stabilization period.

SECTION II APPARATUS

2.1 TEST ARTICLE

2.1.1 ATS Spacecraft

The spacecraft used for this test is a structural full-scale model of the synchronous altitude, spin-stabilized version of the ATS (S/S version). The spacecraft tested was a flightweight structure (Fig. 1) composed of two main subassemblies, the aft structure assembly and the center structure assembly. The aft assembly is composed of a circular thrust tube, 13 in. long and 29 in. in diameter, an intermediate bulkhead, aft ring frame, and eight radial ribs. The center structure includes a sheet metal center thrust tube, 19 in. long and 29 in. in diameter. The spacecraft is a right circular cylinder with a nominal diameter of 57.82 in. and is equipped with a single cylindrical forward solar panel and eight aft, 45-deg segmented panels. The phased array communications antenna mounted on the aft end of the spacecraft was not installed for this test. The length of the basic spacecraft, excluding the apogee motor nozzle and any antennas, is 53.2 in. The overall length of the spacecraft from the separation plane to the apogee motor nozzle is 60.5 in. (Fig. 1b).

An annular ring honeycomb shelf (forward shelf) attaches by screws to the forward end of the center thrust tube and provides a mounting surface for electronic units (Fig. 1a). For this test, the normal complement of electronic packages was replaced by dummy units which possess thermal characteristics comparable to those of the flight spacecraft.

The apogee motor was mounted in the spacecraft with its thrust axis coincident with the spacecraft spin axis.

2.1.2 Apogee Motor

The ATS apogee motor (Fig. 2) is a full-scale, flightweight, solid-propellant rocket motor with a 6A1/4V titanium alloy case and an aluminum thrust attachment ring brazed to the forward hemisphere. This ring provides a mounting attachment to the spacecraft and a means to transmit the motor thrust to the spacecraft. The nozzle is partially submerged and incorporates a graphite throat insert which extends to the divergent portion of the exhaust nozzle to an area ratio of 1.15. From an area ratio of approximately 1.15 to 7.2, the nozzle is

fabricated of carbon cloth phenolic, and from an area ratio of 7.2 to the exit plane, it is fabricated of silica cloth phenolic. The slightly contoured nozzle has a nominal area ratio of 35 and an 11-deg half-angle at the nozzle exit. The nozzle contains the throat closure to prevent foreign matter and moisture from entering the motor. The motor diameter is 28 in. with an overall length slightly more than 54 in. ; with the igniter safety and arming (S/A) device, this dimension increases to approximately 57 in.

The motor case is insulated with Gen Gard V-52 material and loaded with a nominal 760 lb of JPL 540 solid propellant. The total motor weight is approximately 850 lb.

The ignition system for the motor consists of a basket-type igniter manufactured by JPL, a S/A device manufactured by Harry Diamond Laboratory (HDL), and two single-bridge Hi-Shear PC-37 electric squibs. The squibs initiate burning in the JPL basket-type igniter loaded with aluminum-potassium perchlorate pyrotechnic (ALCLO) pellets and slugs (Fig. 3).

The ATS spacecraft apogee motor is manufactured by JPL and is designated as JPL-SR-28-3. The motor has performance characteristics identical to the two JPL-SR-28-1 motors fired for ballistic performance evaluation in the Propulsion Engine Test Cell (T-3) in May 1965 (Ref. 2). The motor is a 3:1 progressive burner with a nominal maximum thrust of 6350 lb at a chamber pressure of 263 psi. Burn time at the nominal loading is 44 sec. Specific physical characteristics for motor JPL-SR-28-3 are presented in Table I.

2.1.3 Separation System

A separation system (Fig. 4) was used to physically disconnect the spacecraft from its attachment to the test cell along the longitudinal axis. This action eliminated any conductive heating from the spacecraft to the test cell through the thrust abutment during the post-burn heat soak period. A separation clamp holds the spacecraft in place at the separation interface along the thrust axis; when a separation is desired, a signal is sent to the separation clamp squib (PC-10) which shears a nonfragmentary separation bolt and releases the clamp; compressed springs between the spacecraft and the thrust abutment side of the interface force the spacecraft away, and inertia carries the soft mount stand (on wheels) downstream from this hard point. A latching device, which is part of the soft mount, will engage and retain the spacecraft approximately 2 in. away from the thrust abutment side of the interface.

2.2 TEST CELL AND INSTALLATION

The motor/spacecraft was tested in Propulsion Engine Test Cell (J-5) (Ref. 3), a horizontal test cell designed for testing solid-propellant rocket motors with up to 100,000-lb thrust and at simulated pressure altitudes in excess of 100,000 ft. The cell is a cylindrical section 16 ft in diameter and 50 ft long (Fig. 5).

Axial thrust was reacted by the thrust abutment which is mounted on two 33-in. I-beams, which are anchored to the cell foundation (approximately 600,000 lb of reinforced concrete). The yaw, pitch, and roll restraints were reacted directly to the same two beams.

The test cell is equipped with a temperature conditioning system designed to maintain the test cell and motor at any prescribed temperature between 60 and 100°F from motor installation until pre-fire pump-down.

The spacecraft apogee rocket motor discharged into a 36-in. -diam exhaust diffuser duct which has a 15-deg conical inlet. The exhaust-gas mixture flowed through a diffuser duct to a spray cooler which reduced the temperature and volume of the exhaust gases, which were then pumped to atmospheric pressure by rotating exhaust machinery.

2.3 FORCE MEASURING HARDWARE

The force measuring system, a single-component thrust stand (soft stand), was designed, fabricated, and assembled by Hughes Aircraft Company (HAC) to fit the size and performance specifications of the ATS apogee solid-propellant rocket motor. The soft stand was inspected to ensure critical dimensions which would allow alignment in the test cell to a tolerance of $\pm 1/64$ in.

The soft stand device (Fig. 4) consists of an ethafoam cradle and restraint pads in which the spacecraft rests with its spin axis parallel to the local horizontal. Upon ignition of the motor, the soft mount precluded the normal vibration accompanying hard attachments to fixed test cell interfaces or attachment points.

2.4 INSTRUMENTATION

Instrumentation was provided to measure motor and spacecraft component temperatures, test cell pressure, spacecraft motor-induced vibration, motor case strain, and plume heat flux.

Pressures were measured with bonded strain-gage-type transducers; the temperatures were sensed by copper-constantan and iron-constantan thermocouples; the motor-induced vibration was sensed with crystal accelerometers; the motor case strain was measured with motor case bonded strain gages; and the exhaust plume heat flux was sensed by narrow and wide view (water-cooled) radiometers. The pressure channels were spanned using values from laboratory calibrations, whereas the thermocouples were connected to a 150°F reference junction and spanned with a National Bureau of Standards (NBS) temperature table as a basis (Ref. 4). The accelerometer channels were standardized using a shaker and a standard accelerometer, and then they were spanned by the voltage substitution method. The motor case strain and the exhaust plume radiometer was spanned using the full-scale output voltage supplied by the manufacturer. The locations of the data sensing elements are given in Figs. 6 and 7 (thermocouples) and Fig. 8 (accelerometers).

The thermocouples, pressure transducers, strain gages, and radiometer outputs were recorded on digital data acquisition systems with a nominal error from input to output tape of ± 0.1 -percent full range. The vibration data was recorded on an FM system with a 5000-cps flat response.

A multi-input, analog-to-digital converter (Micro SADIC[®]) was used to record the primary data (spacecraft component temperatures) on a magnetic tape system which stored the time-shared channels for reduction at a later time by a digital computer. The remaining data were recorded in analog form on a digital tape system (Vidar[®]) and on a 54-kc FM tape system. The digital data system recorded in the following manner: A magnetic tape system, recording in frequency form, stored the signals from the converter for reduction at a later time by an electronic digital computer or by a Honeywell 9300 Automatic Wave Analyzer in the case of the vibration data. The digital computer complex provided a printed tabulation of absolute values and total integrals at time intervals of 0.01 sec, whereas the wave analyzer provided power spectral density plots in g^2/cps versus frequency.

The Vidar digital data system is equipped with an adjustable full-scale resolution for various input voltages. This feature allows the voltage outputs associated with various transducers to be associated with a full-scale digital resolution.

The oscillograph, recording with a paper speed of 40 in./sec, provided an independent backup of all operating instrumentation channels except the temperatures. Selected channels of motor case strain, test cell temperature, test cell pressure, and motor/spacecraft temperatures

were also recorded on null-balance strip charts for immediate analysis following the test firing.

Visual observation of the motor firing was provided by a closed-circuit television monitor. High speed (nominal 5000-frames/sec) optical recorders were used to provide a permanent visual record of the test firing.

2.5 INSTRUMENTATION CALIBRATION

The pressure transducers were physically calibrated and certified with NBS secondary standards in a laboratory before installation in the test cell. After installation of the various transducers in the test cell, the pressure, the vibration, and the temperature instrumentation systems were calibrated at sea-level and then at pressure simulated altitude conditions using the voltage substitution method. This means the data recording systems were calibrated by a laboratory-devised, electrical step calibration which simulated a known input signal level. These calibrations were automatically selected from the control room. This procedure allowed calibration of the complete instrumentation systems at pressure simulated altitude conditions immediately before the test firing.

The vibration data system at LRF was standardized end-to-end with a shaker and standard accelerometer. The accelerometers used were calibrated and certified by the user (HAC), whereas the charge amplifiers were calibrated and certified in the secondary standards laboratory at AEDC.

The spacecraft thermocouples were connected directly to the reference temperature junction, and NBS standard thermocouple curves were the basis of the temperature data calibrations. The reference junctions were calibrated and certified by the secondary standards laboratory at AEDC.

The strain-gage and radiometer instrumentation systems were not calibrated. The data were recorded and transmitted in millivolts versus time.

SECTION III PROCEDURE

Upon arrival at AEDC, the JPL-SR-28-3 motor assembly was stored in a temperature-controlled bunker at $70 \pm 10^\circ\text{F}$. A physical and

radiographic inspection was made of the ATS apogee motor grain to determine if any damage had been caused in transit and to ensure that the motor was acceptable for firing at LRF.

The motor was assembled and installed in the spacecraft according to approved procedures at the LRF rocket preparation area (Fig. 9) in a 70°F temperature environment. Before firing, the motor nozzle was measured (throat and exit diameters), and the assembled motor was weighed.

The motor/spacecraft system was installed (Fig. 10) in the test cell where the internal temperature was 70°F during the pre-firing installation, alignment, and calibration procedures.

When the instrumentation hookup, checkout, and sea-level calibrations were completed, the test cell was sealed, and the pressure was reduced to the desired pressure simulated altitude conditions using rotating exhaustor machinery; at this time, the altitude pre-firing calibrations were performed at a nominal test cell pressure of 0.3 psia.

After the altitude calibrations were performed and the calibrations reduced (to engineering units) and found to be satisfactory, the firing circuit resistance was adjusted to give the desired firing current of 5 amp/squib at 28 vdc.

A countdown procedure was initiated which operated the cell support functions, activated the entire data recording-measuring complex, and fired the motor. Immediately after the motor firing, the separation system was activated, and the data complex was used to record spacecraft temperatures to 3600 sec after motor ignition. Then the post-firing altitude calibrations were performed and recorded, and the test cell pressure was returned to sea-level conditions. The expended motor and spacecraft were removed and thoroughly inspected to document the post-firing conditions.

SECTION IV RESULTS AND DISCUSSION

A HAC, ATS spacecraft (S/N T-4) was tested at simulated altitude primarily to determine the thermal environment which was created by the fired apogee motor retained within the spacecraft and to record the motor-induced vibration. Documentation of the motor altitude ignition capability and structural integrity at near vacuum conditions was also

accomplished. A careful investigation of the motor internal conditions was made as soon as practical after the firing.

4.1 SPACECRAFT THERMAL DATA

The testing in Test Cell J-5 was primarily concerned with the thermal environment created by the solid-propellant apogee motor which is retained within the ATS spacecraft. The measured temperatures are an indicator of the thermal environment the electronic components will encounter in space. These data also indicate the time which must elapse (after apogee motor operation) before it is safe to activate the electronic components. The temperatures were sensed with 89 thermocouples, and these data are presented graphically in Fig. 11.

4.1.1 Peak Temperatures

A study of the thermal data indicates that the highest temperature recorded anywhere was 935°F. The thermocouple which sensed this temperature on the motor nozzle (Fig. 11c) became unbonded at 60 to 61 sec after ignition.

The highest temperature recorded on the spacecraft was approximately 400°F and was sensed on the thermal barrier (Fig. 11l) at about 250 sec after motor ignition. The highest spacecraft structural temperature was 240°F (Fig. 11q) and was sensed on the thrust tube approximately 750 sec after motor ignition.

4.1.2 Spacecraft Electronic Temperatures

Generally, it may be stated that all temperatures were within anticipated ranges; however, the thermal barrier and the downstream solar panel (forward solar panel) temperatures were probably affected by the light recirculating reverse flow of the rocket exhaust gases which occurred during apogee motor tailoff. The full influence of these gases upon the electronic components cannot be determined without a free plume test, where there is no exhaust diffuser; however, if the component temperatures measured are within the temperature limits of the spacecraft system, then no serious problem exists because the heating experienced within the test cell is greater than that which would be expected in outer space at hard vacuum.

The spacecraft electronic component temperature data indicate that none of the units exceeded 150°F throughout the entire 3600-sec heat soak period.

4.1.3 Temperature Stabilization

The time at which the various temperatures reached a peak value and began to recede is of interest to those who must determine when each unit may begin safe operation. The apogee motor generally reached a peak temperature at approximately 100 to 800 sec after ignition. The majority of the spacecraft components (excluding thermal barrier or downstream solar panels) reached a peak temperature at about 1500 sec after motor ignition. However, some temperatures barely reached a peak at 3600 sec after motor ignition (Fig. 11r). All peak temperatures which occurred after 1500 sec were clearly less than 200°F.

4.2 SPACECRAFT VIBRATION

Measurement of the motor-induced vibration data was accomplished with accelerometers and with the use of a "soft stand", which was designed to isolate from the spacecraft all ground or test-cell-induced vibrations above 10 cps. The soft stand exhibited a natural frequency of 7 cps along the thrust axis.

The data were recorded on FM tape, and the tapes were transmitted to HAC. These tapes will be used in an extensive study program in which the combined effects of vibration and centrifugal force on spacecraft life will be investigated.

Preliminary analysis of the oscillograph data indicated that maximum accelerations from 10 to 15 g were recorded during motor ignition transient. However, power spectral density (PSD) analysis indicated that the motor operation was smooth, and the levels measured were less than 1 g²/cps. Figure 12 presents an example of the PSD reduced data.

In general, the motor operation was relatively smooth, and the vibration data indicate that during motor burning, no large acceleration forces were detected.

4.3 ALTITUDE IGNITION AND STRUCTURAL INTEGRITY

The apogee motor was ignited at a pressure altitude of 0.10 psia, which corresponds to 110,000 ft (geometric altitude, Z, Ref. 5). The motor operated normally and had a total burning time (t_B) of 43 sec (Fig. 13). The nozzle closure was punctured to demonstrate altitude ignition capability.

The structural integrity of the apogee motor and the spacecraft was excellent following a heat soak period of 3600 sec at an altitude of 125,000 ft (Fig. 14). An investigation of the interior of the apogee motor was made (Fig. 15), and no propellant was found. The insulation condition and nozzle flow erosion will be compared to motors which will be spun (during test firing) at the normal orbital spin speed. The titanium motor case and phenolic nozzle sustained the firing in excellent condition. The nozzle throat experienced a 1.67-percent flow area increase (erosion) (Fig. 16). This is excellent and is a result of the low combustion chamber operation pressure rather than specialized graphite density control.

The spacecraft structure and components exhibited excellent structural integrity (Fig. 17). The pre- and post-firing conditions of the solar panels and thermal barrier are presented in Fig. 18.

SECTION V SUMMARY OF RESULTS

The results of firing one JPL apogee motor within a Hughes ATS spacecraft may be summarized as follows:

1. The highest temperature recorded was on the motor nozzle and was 935°F. This occurred at 61 sec after motor ignition, at which time the thermocouple became unbonded from the nozzle surface.
2. The highest temperature recorded on the spacecraft was approximately 400°F and occurred at 250 sec after ignition. This temperature was located on the thermal barrier. The highest spacecraft structural temperature was 240°F and was sensed 750 sec after ignition.
3. Spacecraft electronic component packages did not exceed 150°F throughout the 3600-sec heat soak period.
4. The motor was ignited at a simulated altitude of 110,000 ft and burned for 43 sec. The thermal data were recorded for 3600 sec after ignition at a simulated altitude of 125,000 ft.
5. The motor and spacecraft vibration data indicate that the motor operation was relatively smooth and did not have any large acceleration transients.
6. The motor and spacecraft exhibited excellent structural integrity throughout the motor firing and post-firing heat soak period.

REFERENCES

1. Applications Technology Satellite, ATS System Summary -- NAS 5-3823, Hughes Aircraft Company, SSD 60028R. (Revised February 1, 1966).
2. Stevenson, C. W. and Nelius, M. A. "Results of Testing Two JPL-SR-28-1 (S/N's P-14 and P-15) Solid-Propellant Rocket Motors under the Combined Effects of Simulated Altitude and Rotational Spin." AEDC-TR-65-186 (AD470354), September 1965.
3. Test Facilities Handbook (5th Edition). "Rocket Test Facility, Vol. 2." Arnold Engineering Development Center, July 1963.
4. National Bureau of Standards, Circular No. 561 (Equivalent MIL-W-5846-A).
5. Minzer, R. A., Champion, K. S. W., and Pond, H. L. The ARDC Model Atmosphere. AFCRC-TR-59-267, 1959.

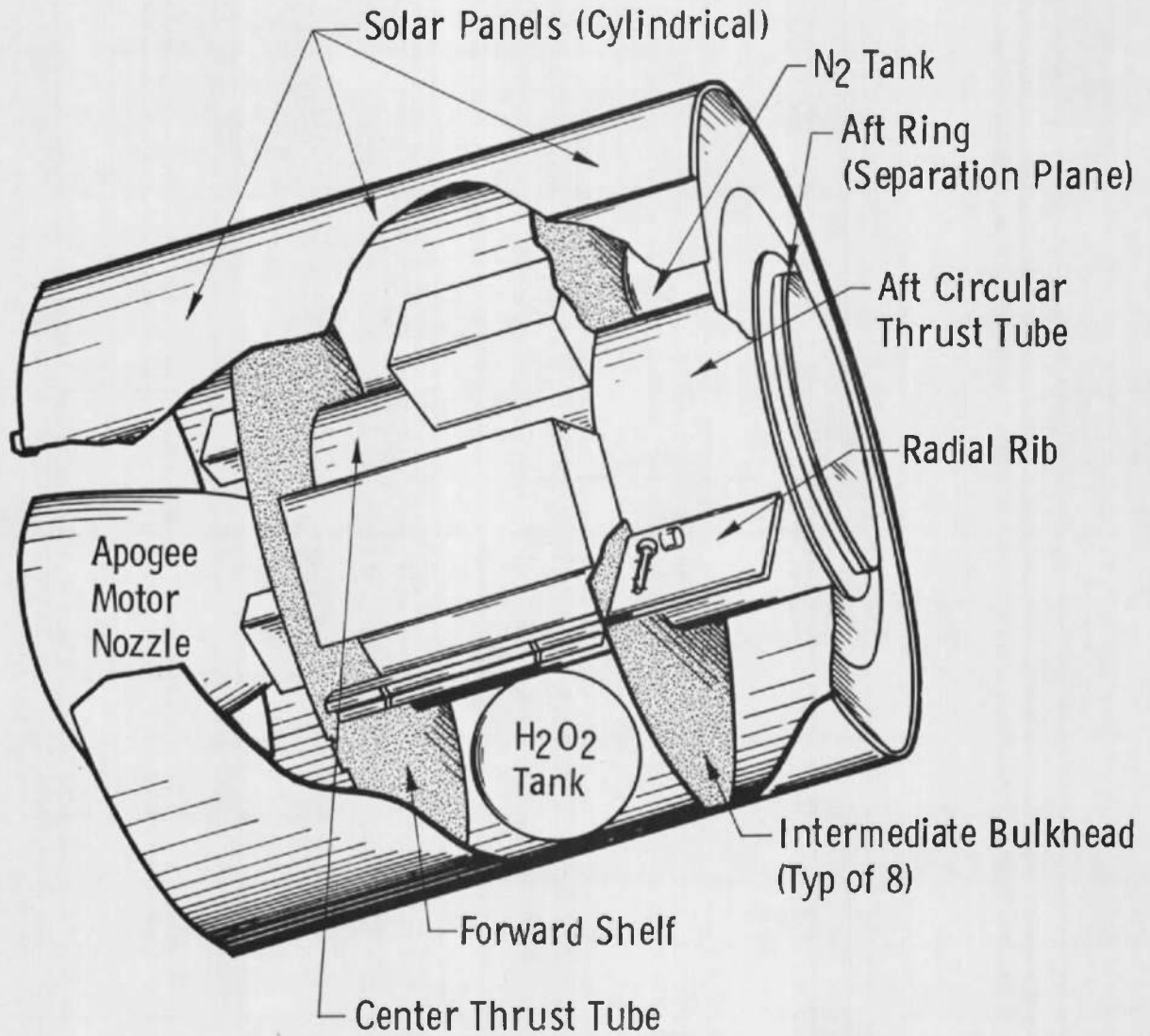

a. Cutaway View

Fig. 1 ATS Flightweight Spacecraft

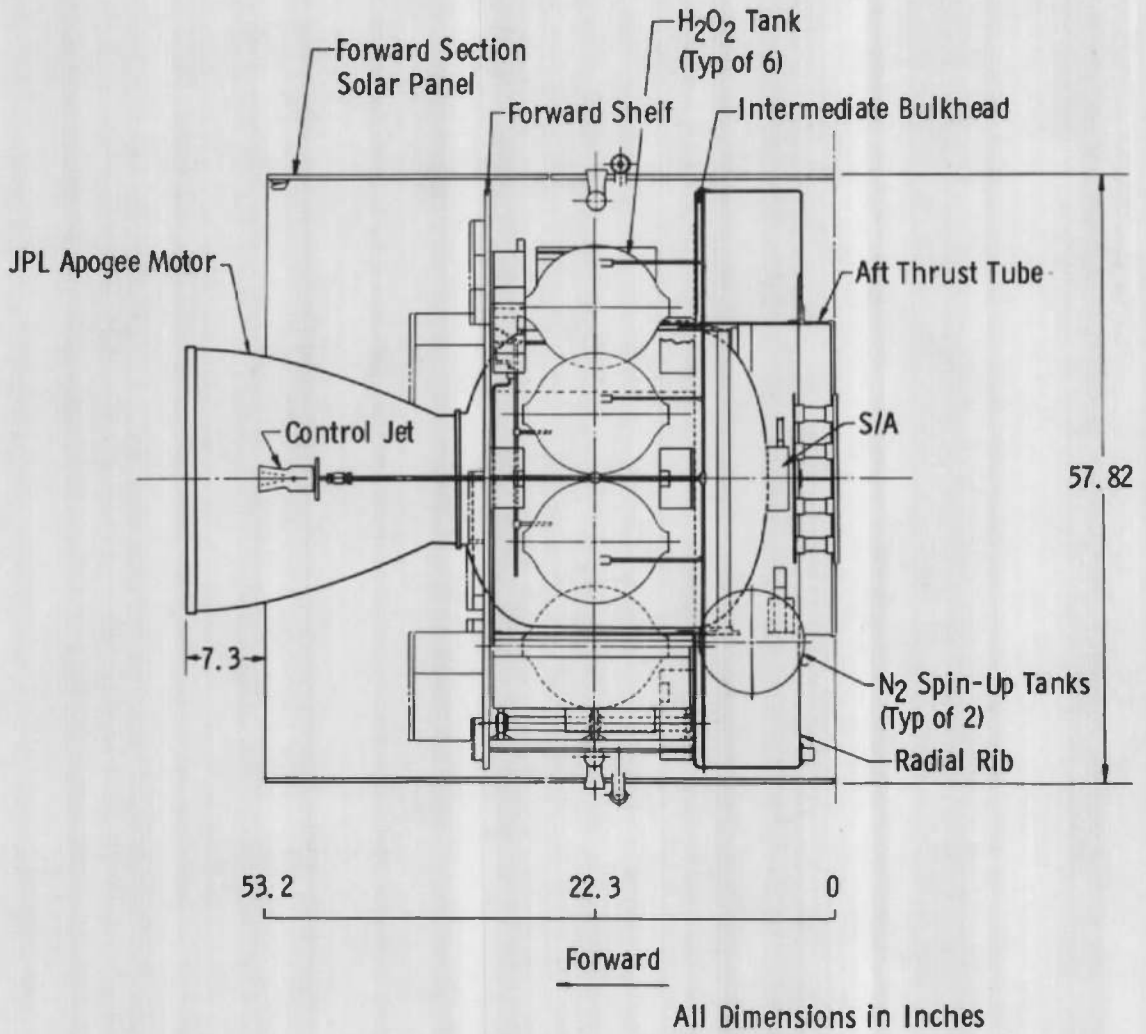

b. Elevation View
Fig. 1 Continued

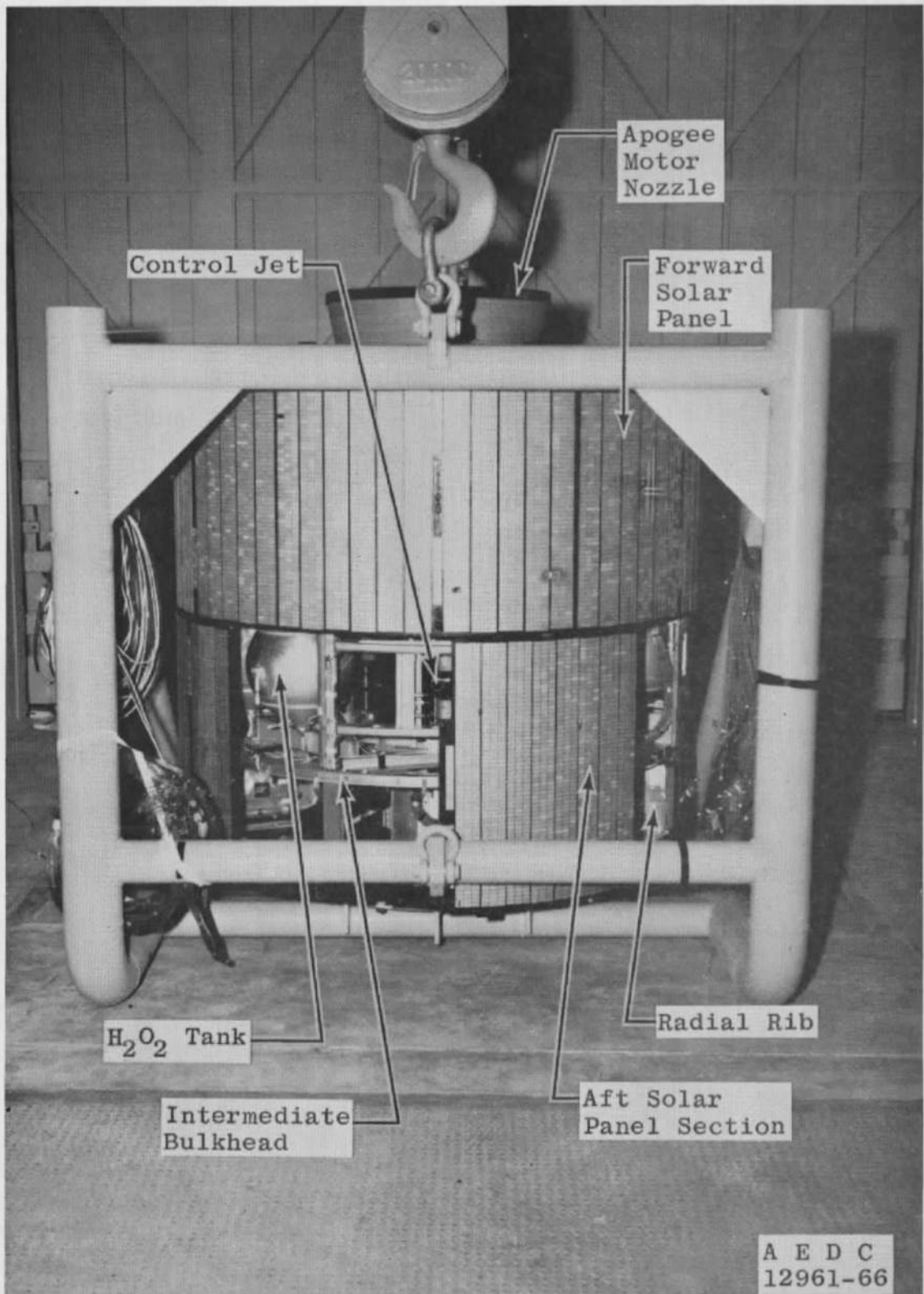

c. Photograph of Solar Panel Section Removed

Fig. 1 Concluded

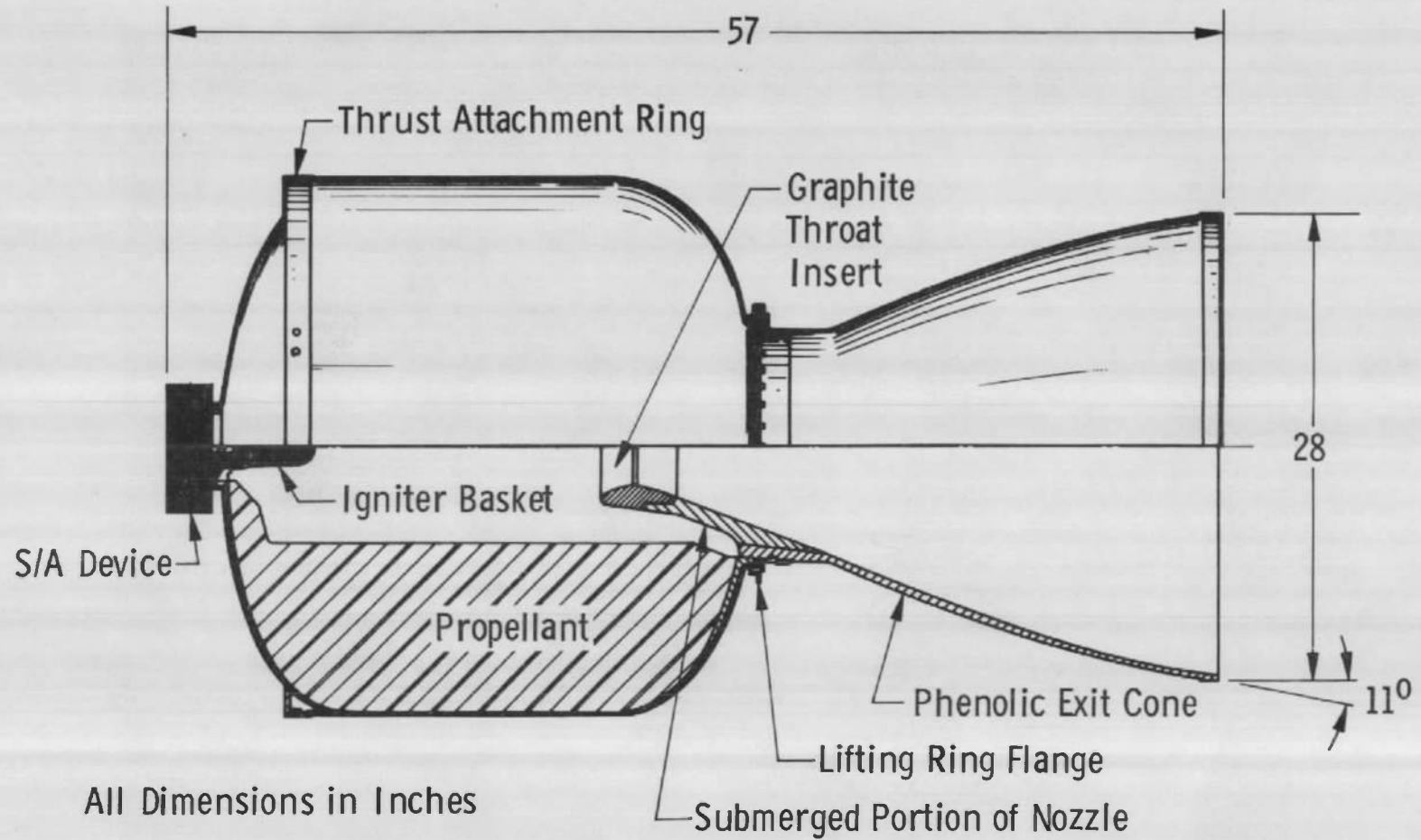

a. Cutaway Schematic
 Fig. 2 ATS Apogee Motor

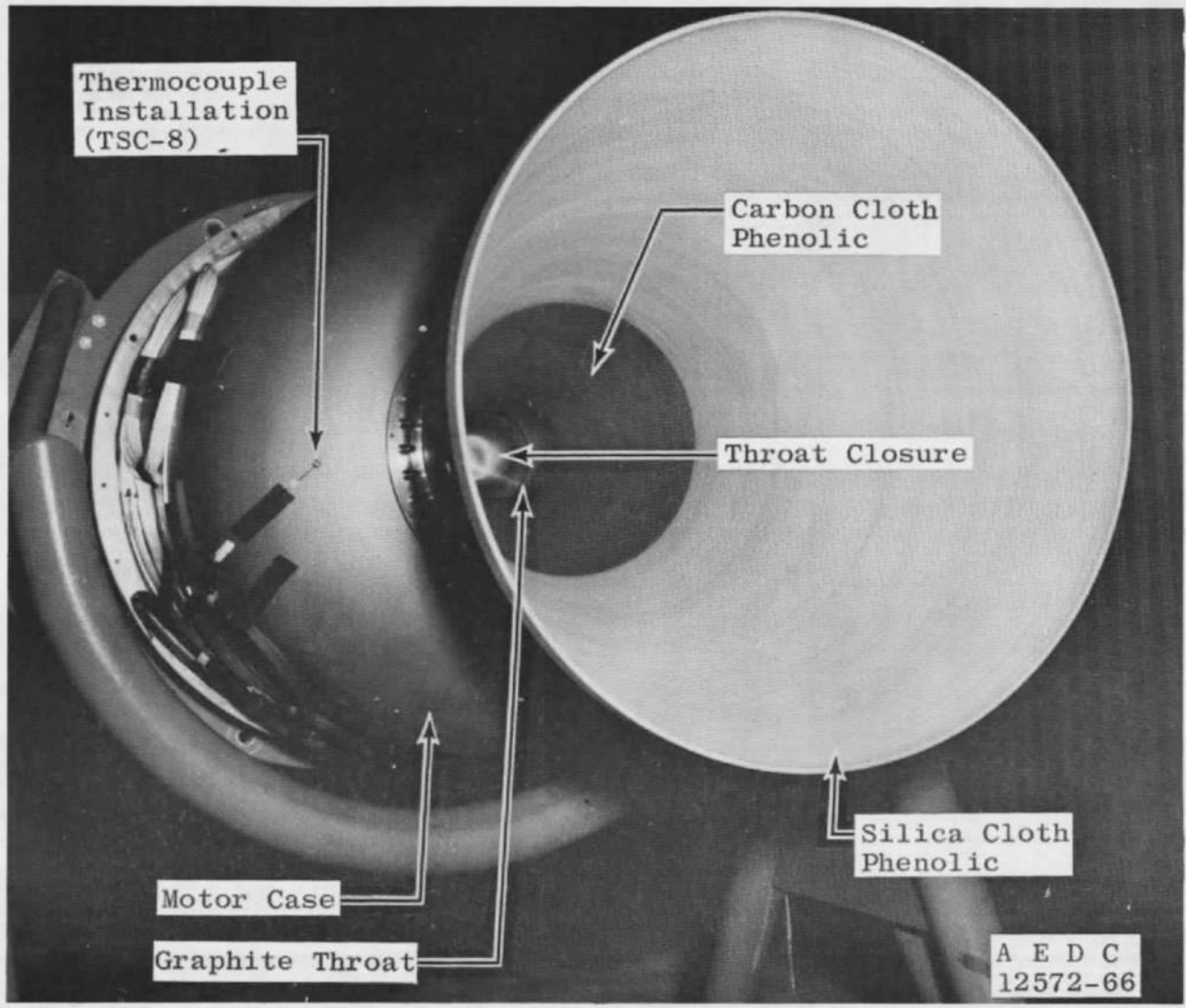

b. Photograph of Nozzle
Fig. 2 Concluded

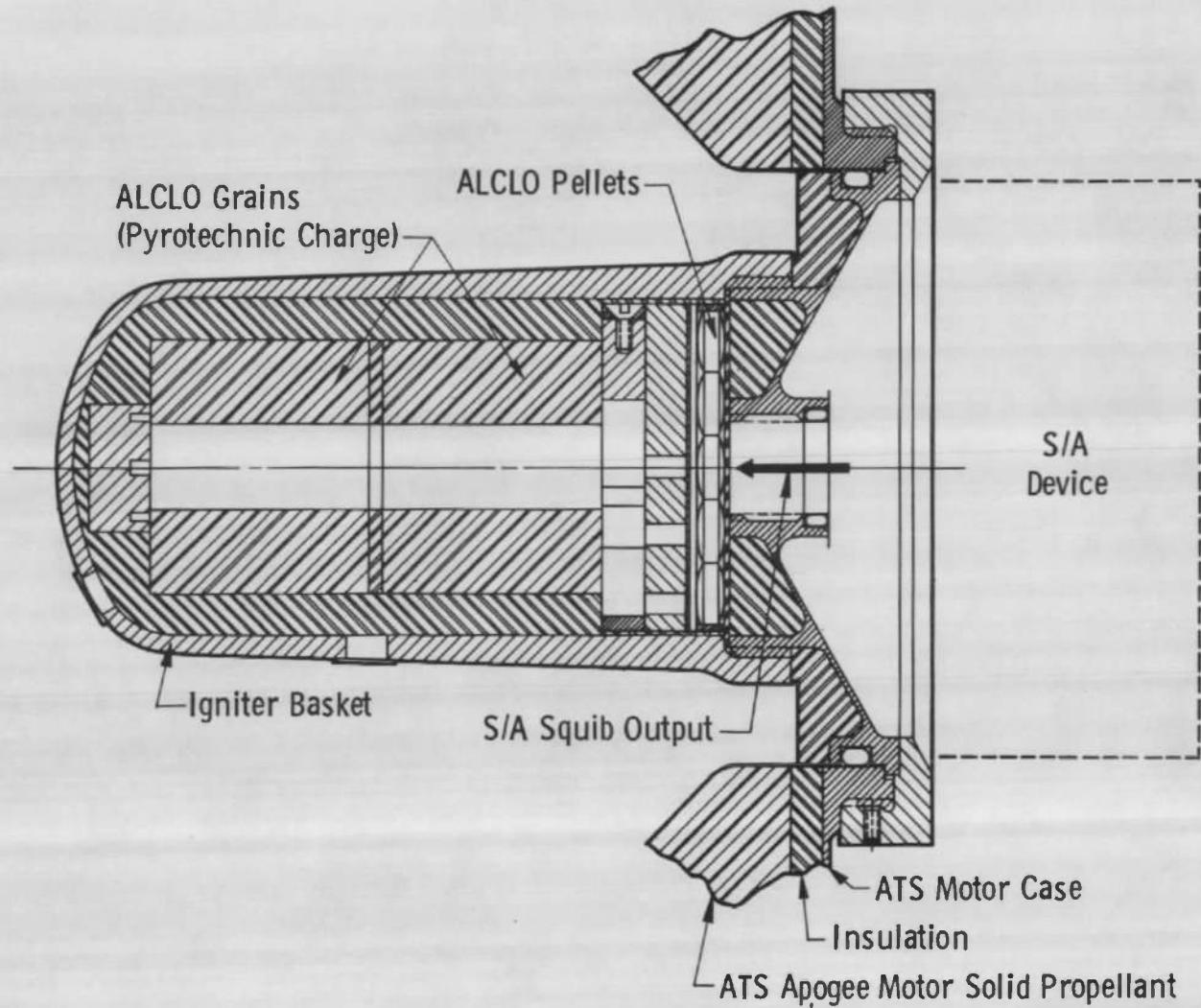

a. Cutaway Schematic

Fig. 3 S/A Igniter Assembly

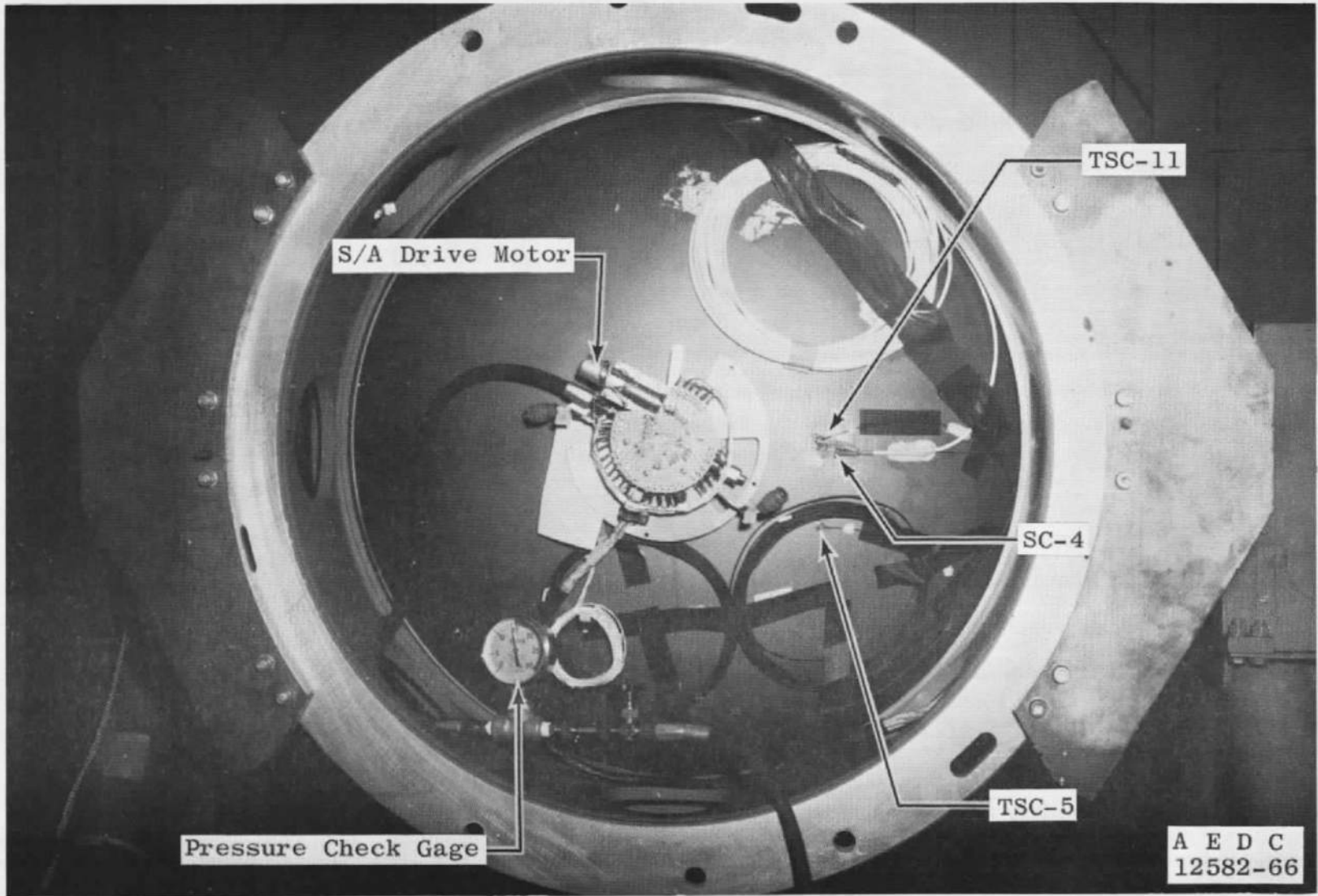

b. Installed into Motor without Cover Plate

Fig. 3 Concluded

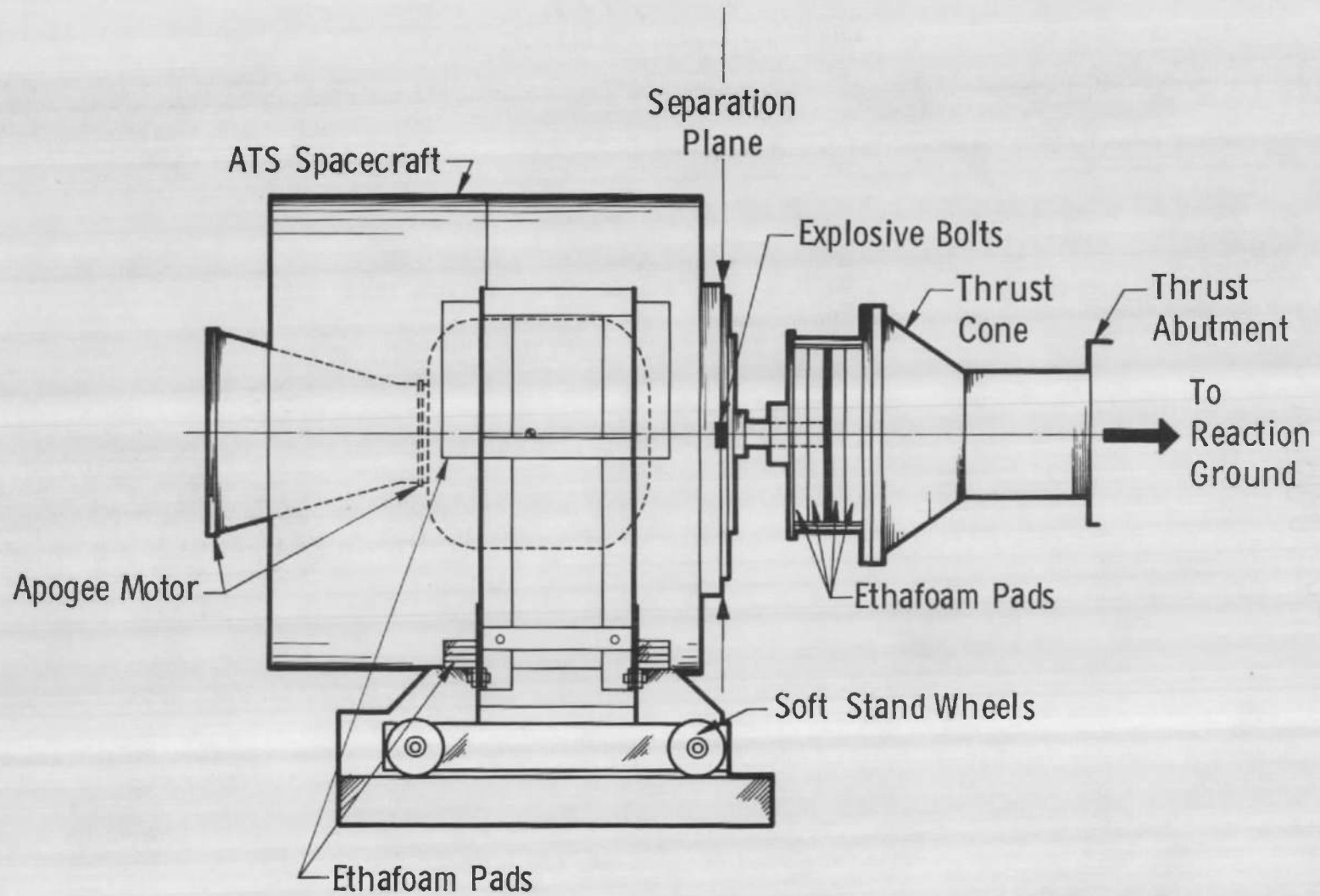

a. Separation System Schematic

Fig. 4 Soft Stand Assembly

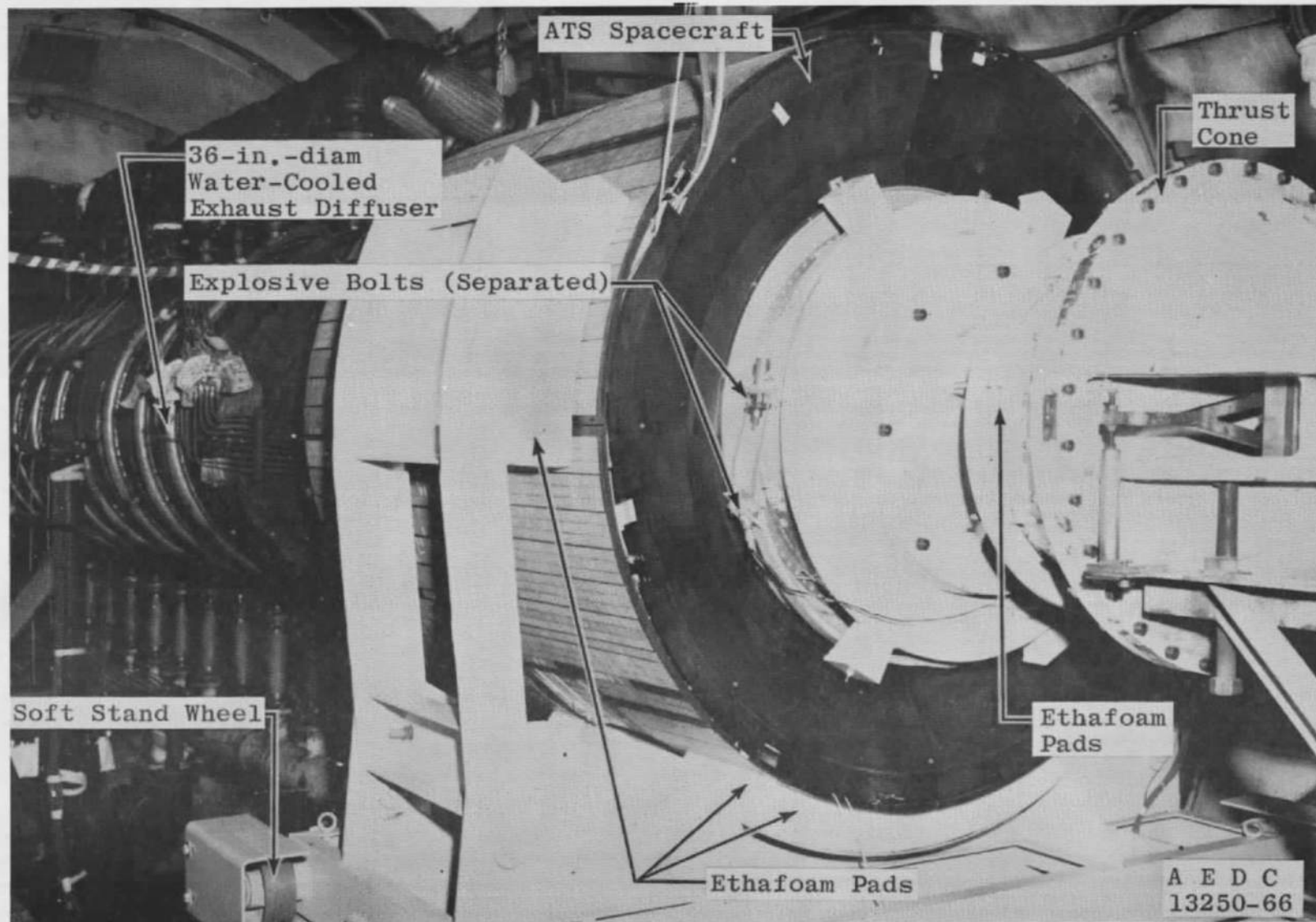

b. Photograph of Explosive Bolts Separated
Fig. 4 Concluded

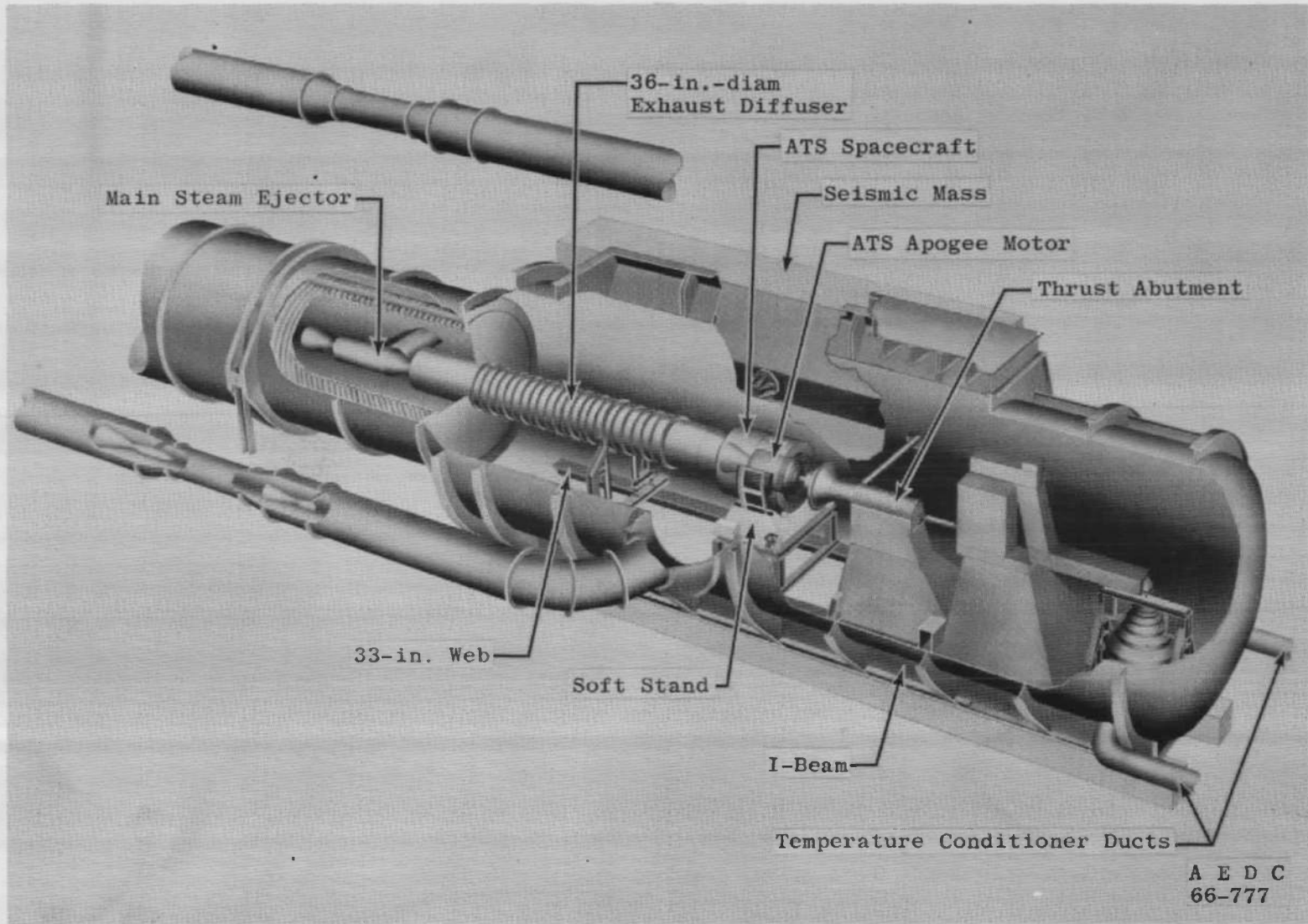
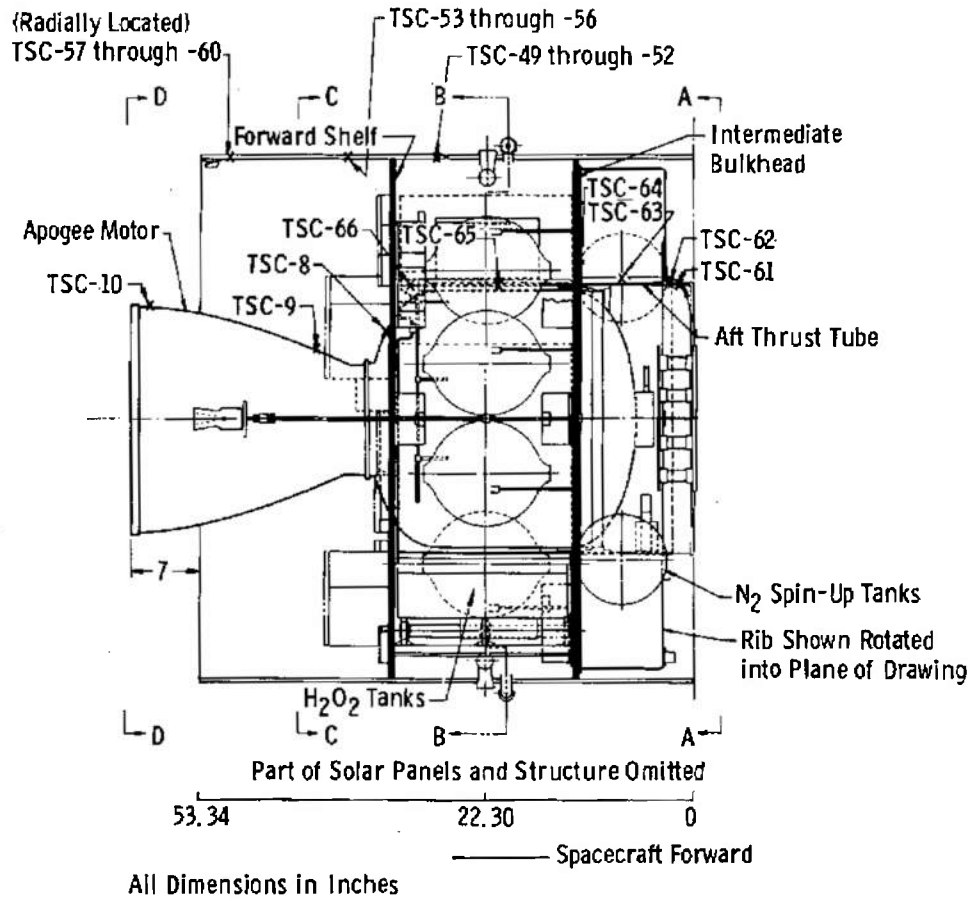
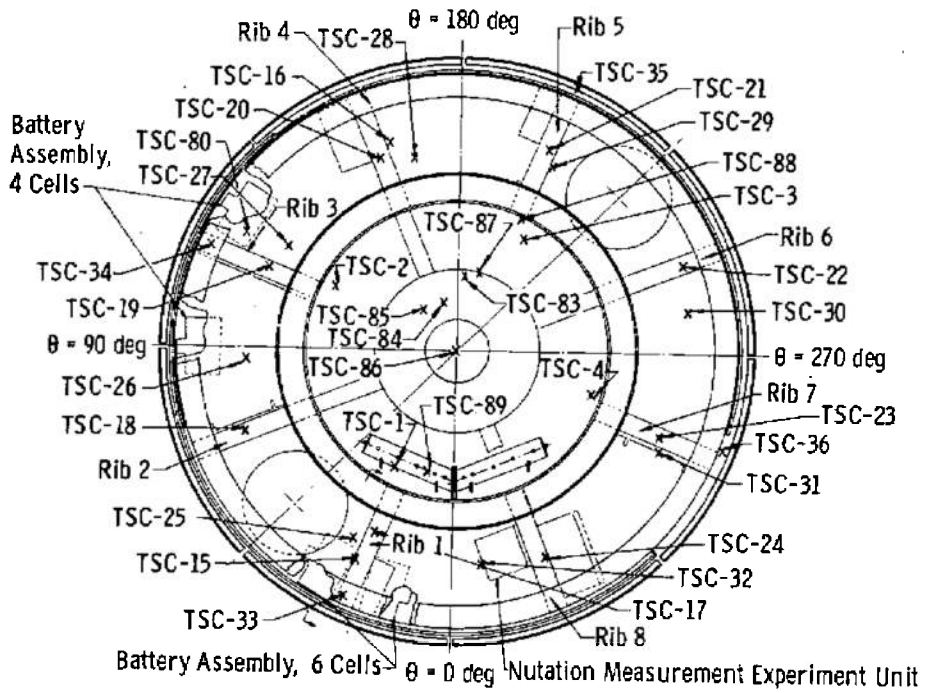

Fig. 5 Isometric Schematic of Test Cell and Installation



a. Elevation View

Fig. 6 Spacecraft Thermocouple Locations



Looking Forward

Section A-A

b. View A-A

Fig. 6 Continued

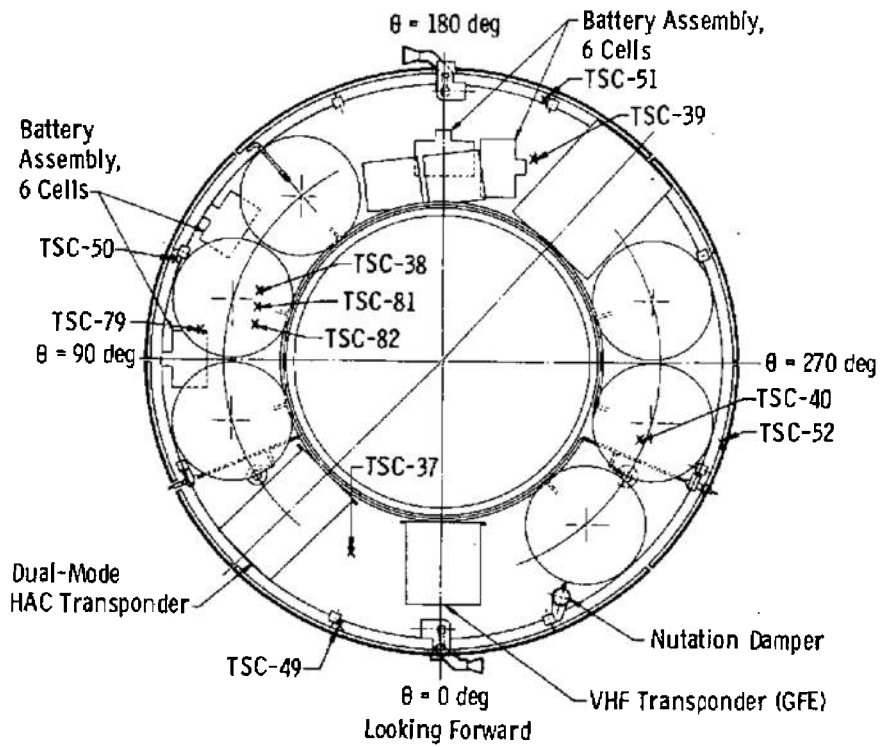

Section B-B

c. View B-B

Fig. 6 Continued

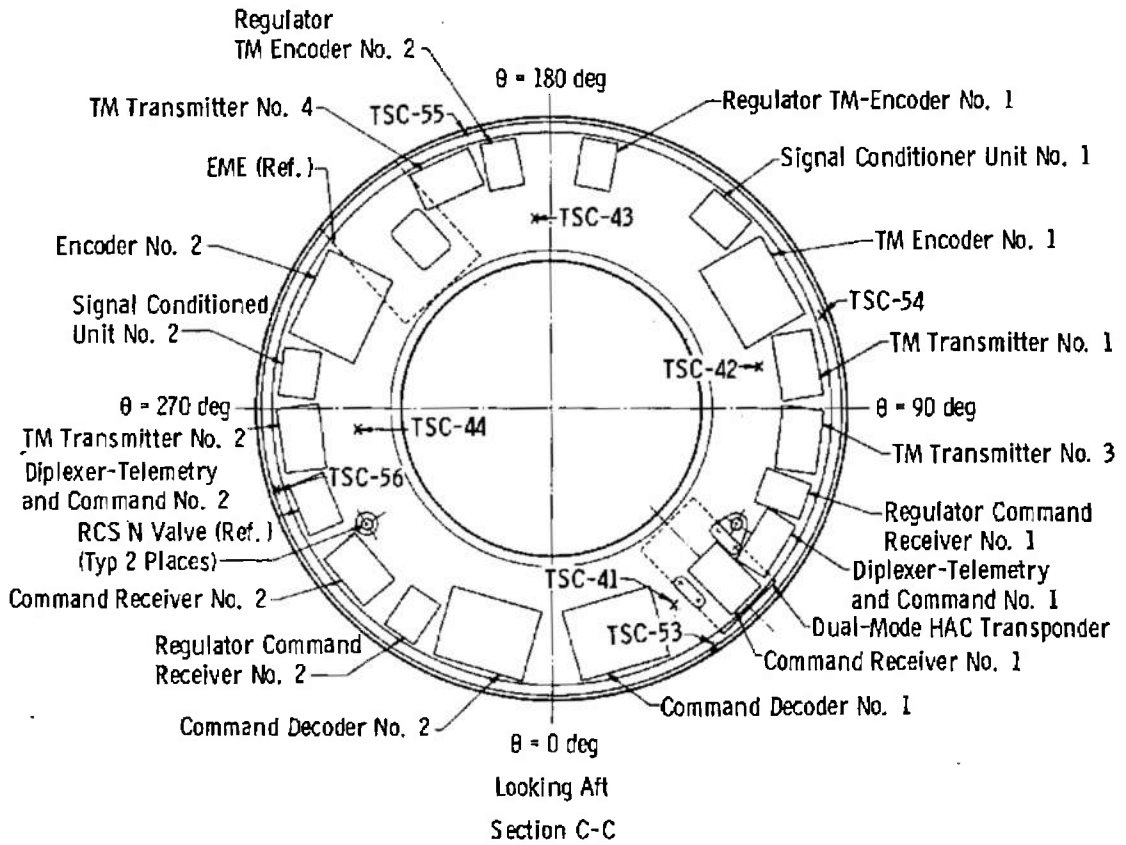

d. View C-C

Fig. 6 Continued

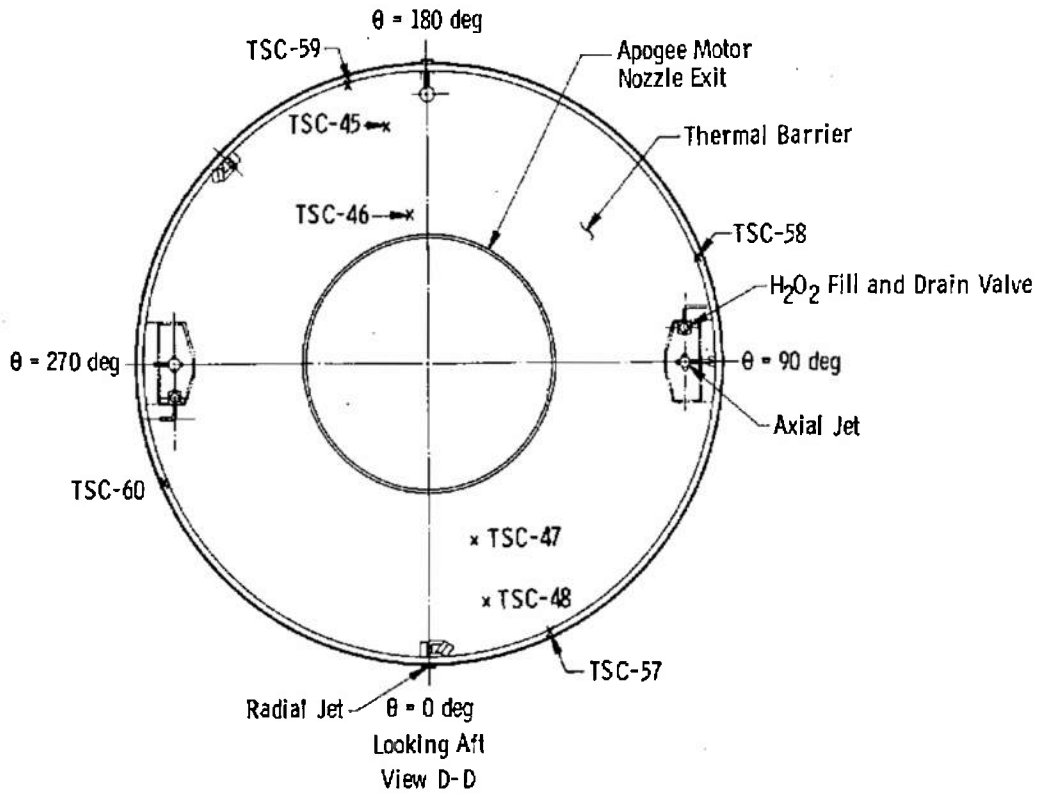

e. View D-D

Fig. 6 Continued

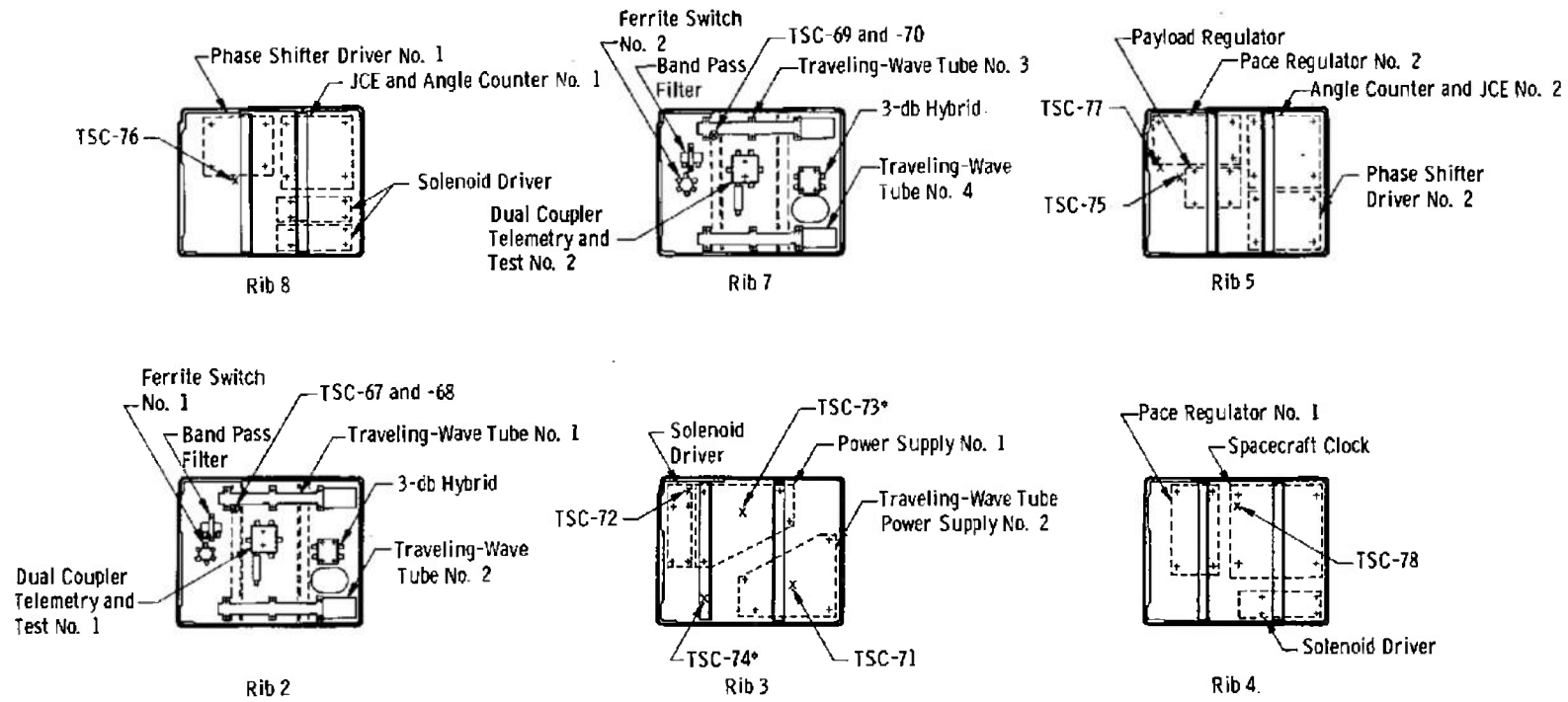

*TSC-73 and -74 are located on transmitter not shown.

f. Rib Instrumentation
Fig. 6 Concluded

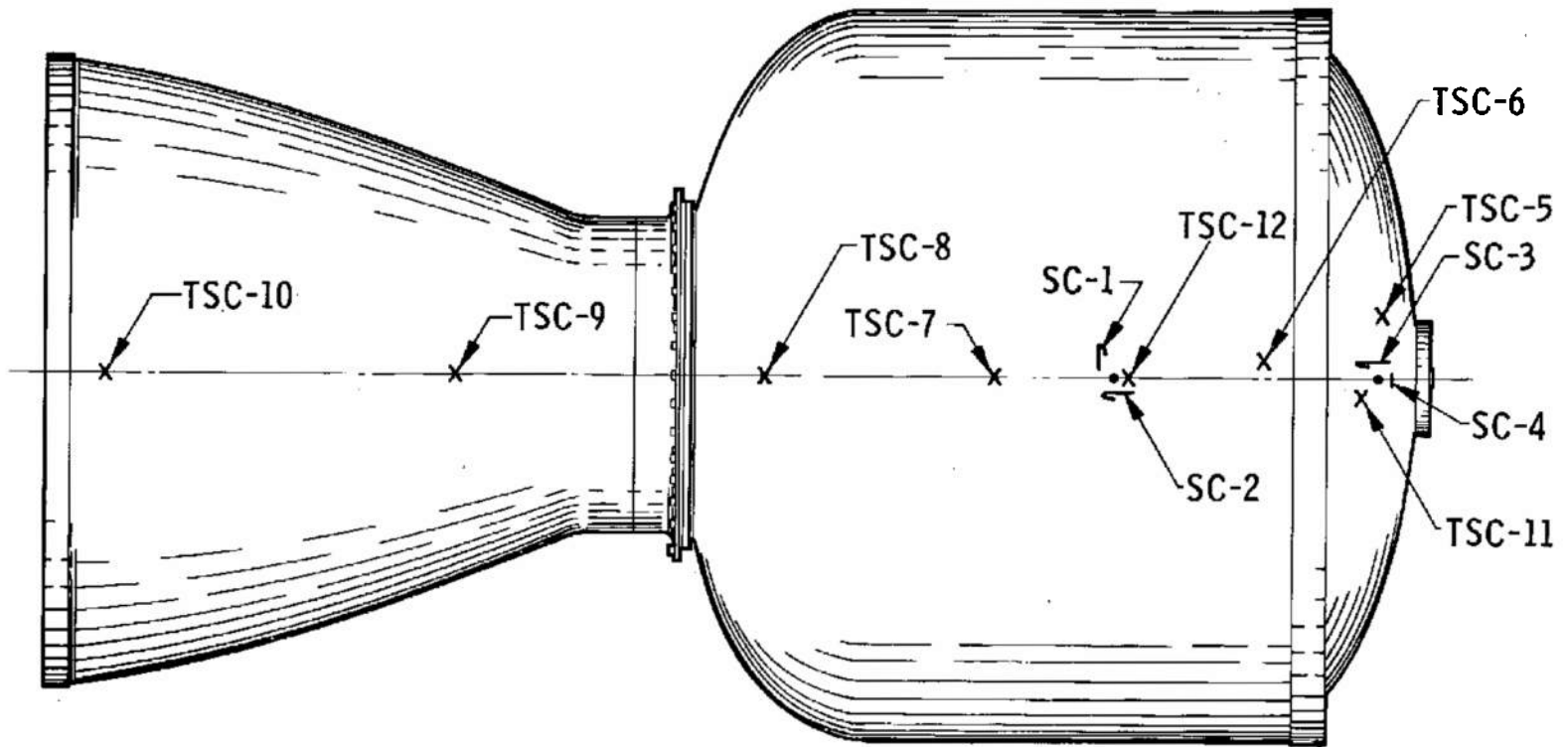
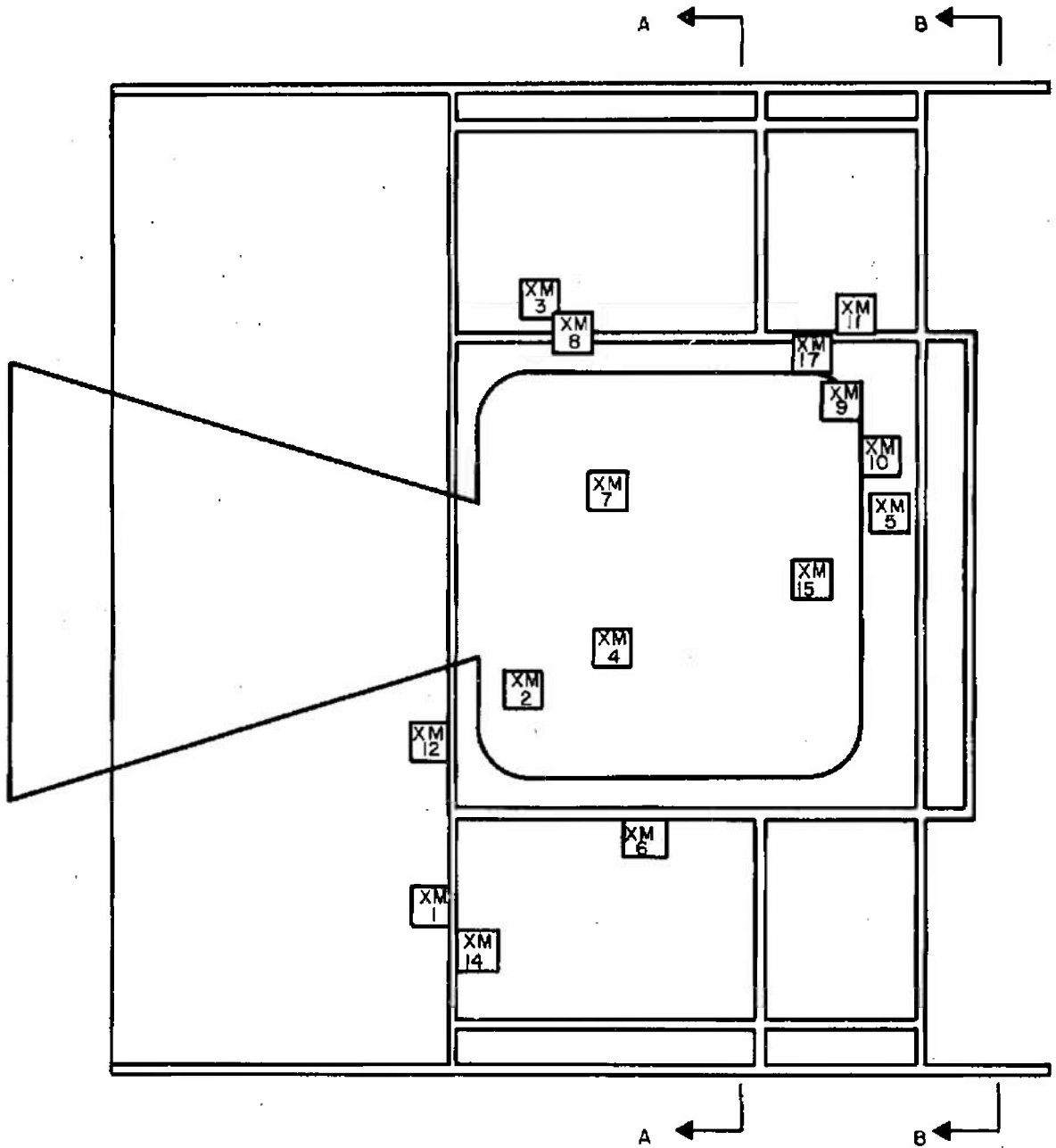

Fig. 7 Motor Case Thermocouple and Strain-Gage Locations



ACCELEROMETER LOCATIONS

NOTE: XM16 AND XM18 LOCATED ON MOTOR MOUNTS
XM16: $\theta=202.5$ DEG, XM18: $\theta=292.5$ DEG

a. Elevation View

Fig. 8 Accelerometer Locations

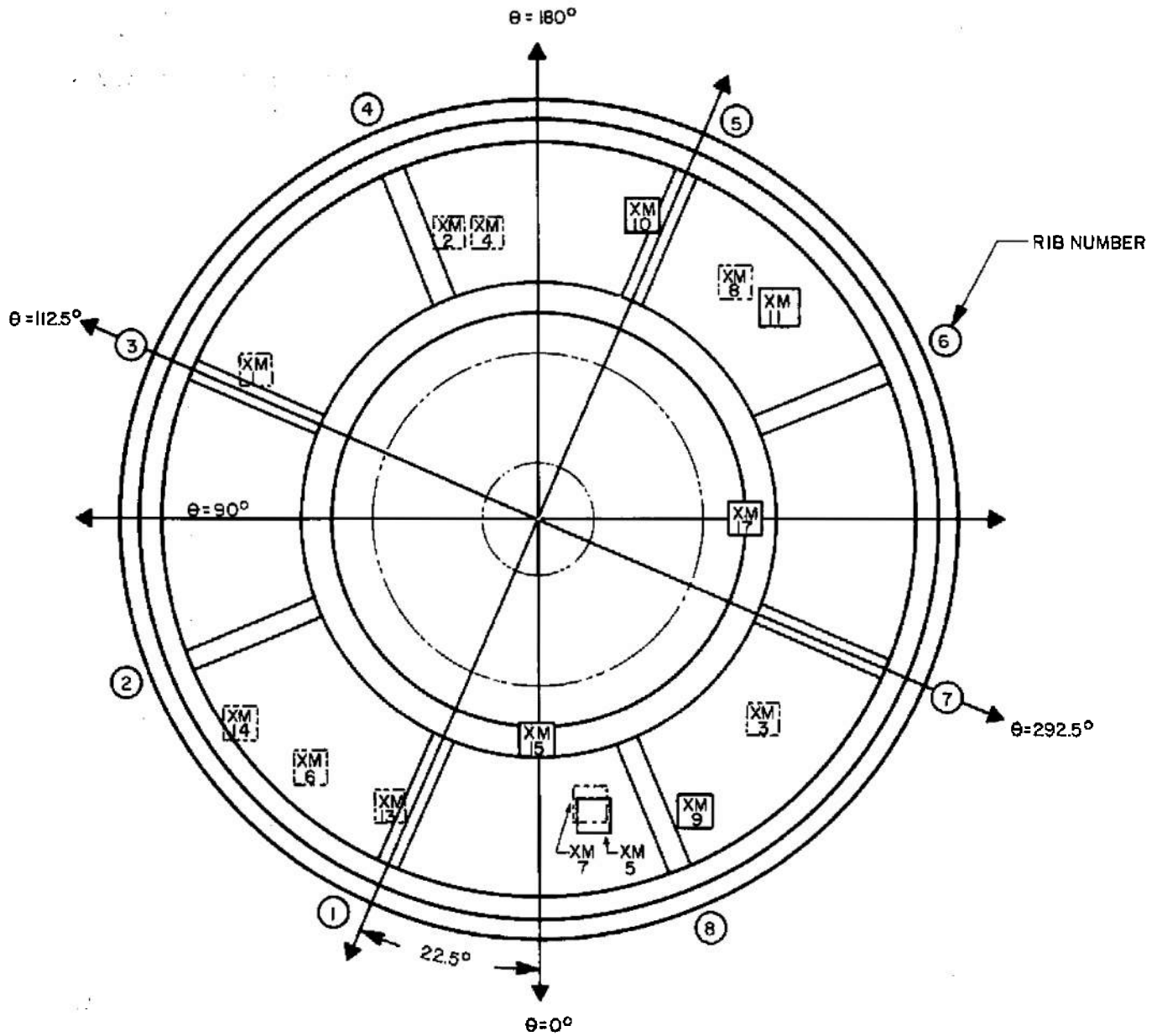

LOOKING FORWARD

VIEW A-A -----

VIEW B-B _____

b. End View

Fig. 8 Concluded

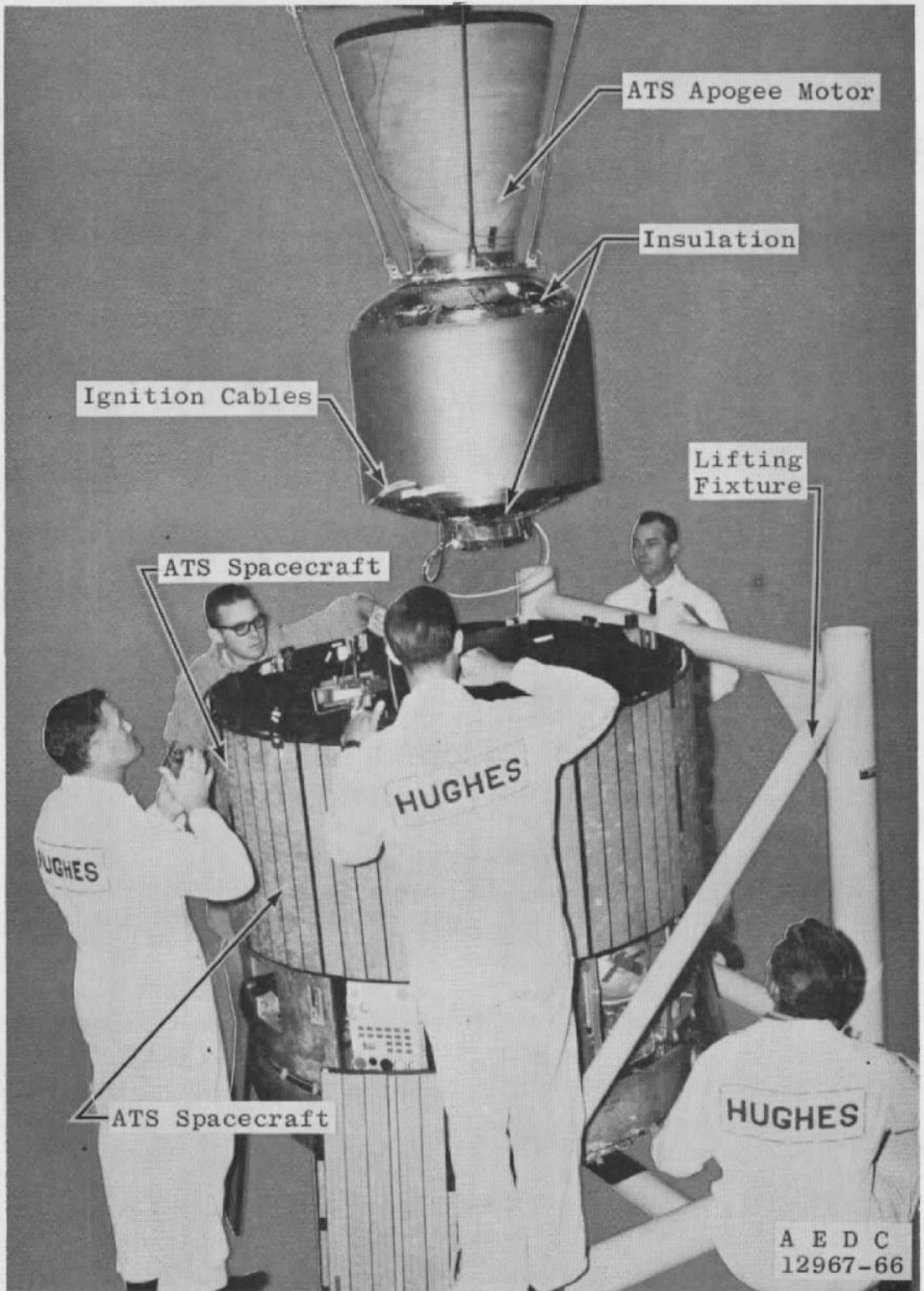
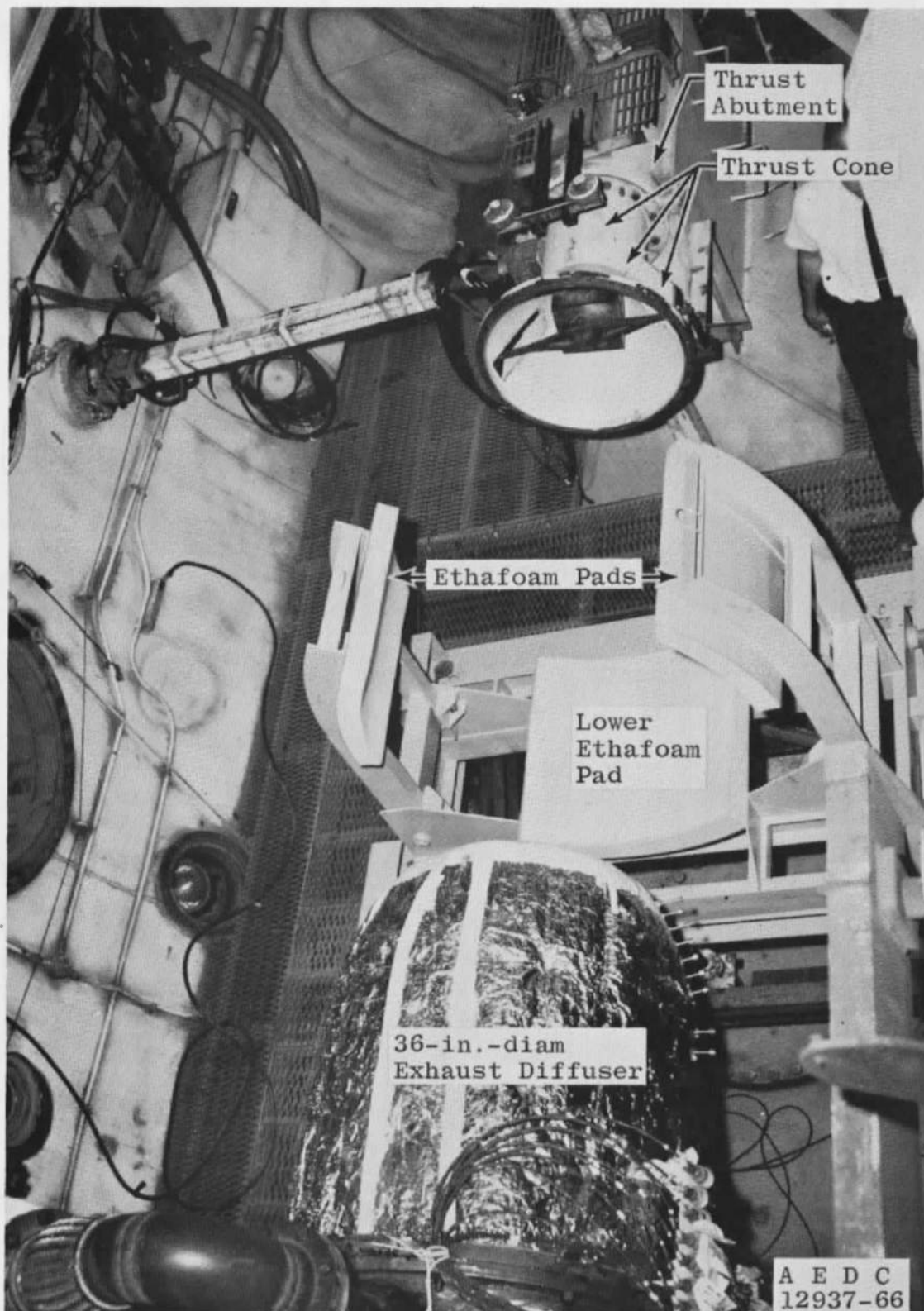
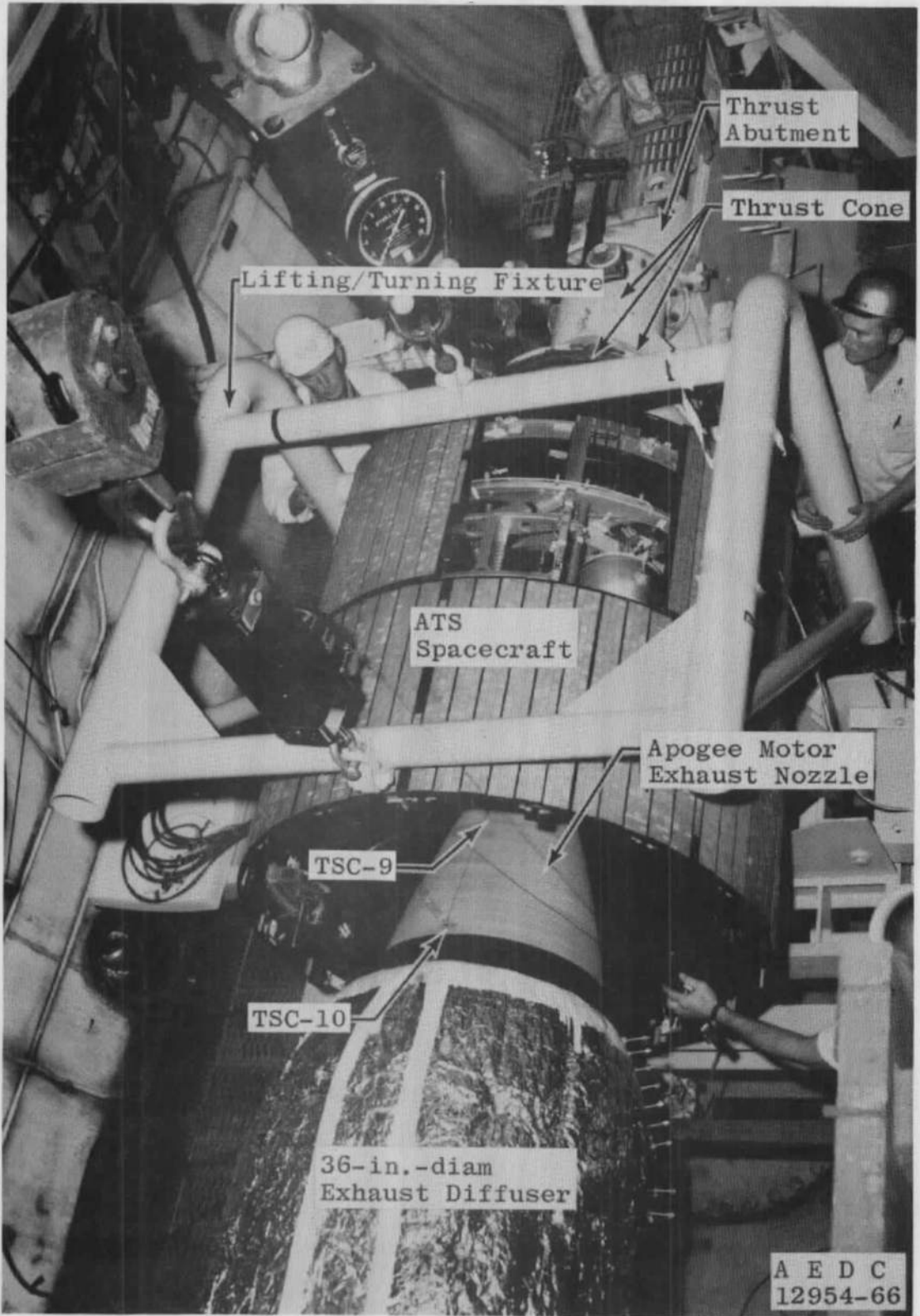

Fig. 9 Motor/Spacecraft Assembly Operations



a. Empty Soft Stand

Fig. 10 ATS Installation in Test Cell



b. Spacecraft Lowered into Place

Fig. 10 Concluded

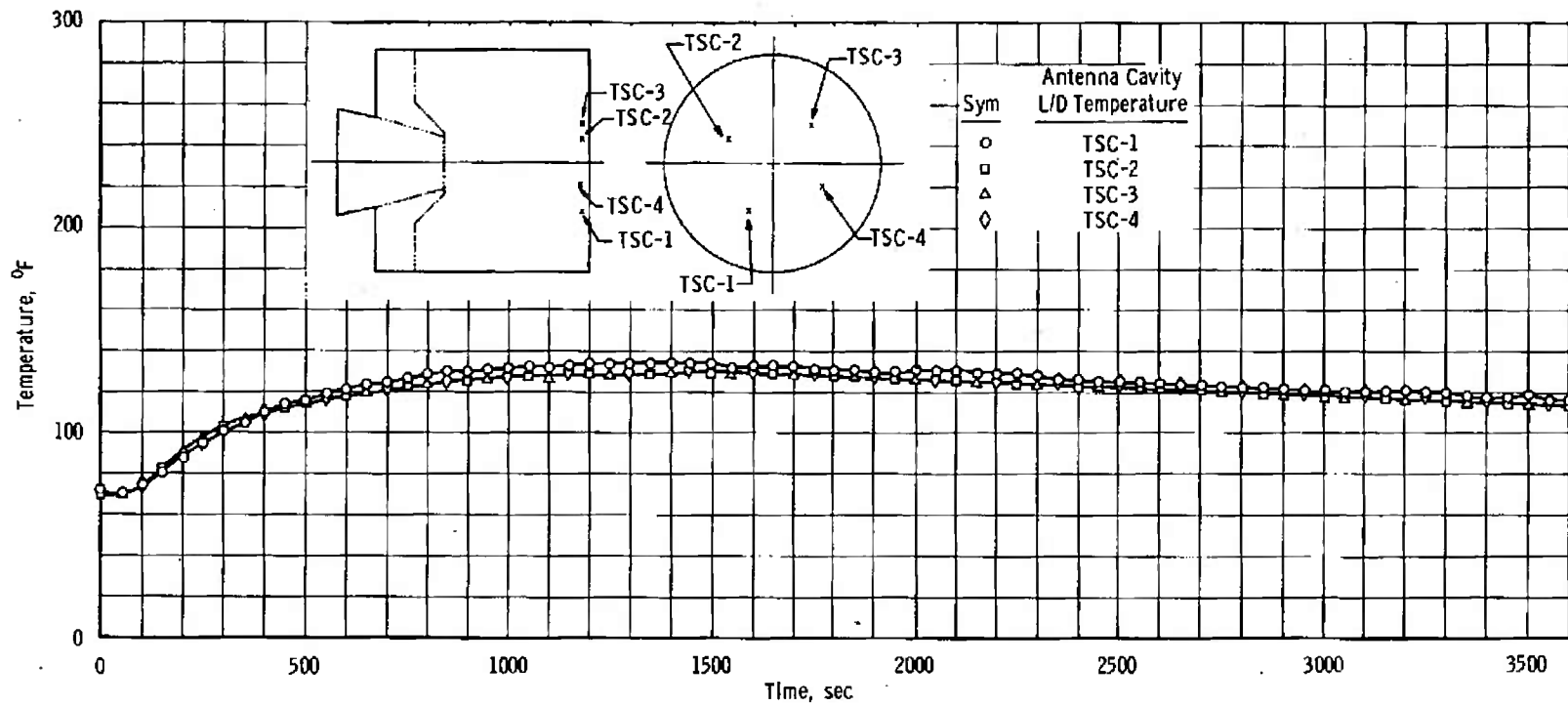

a. TSC-1 through -4
 Fig. 11 Temperature Data

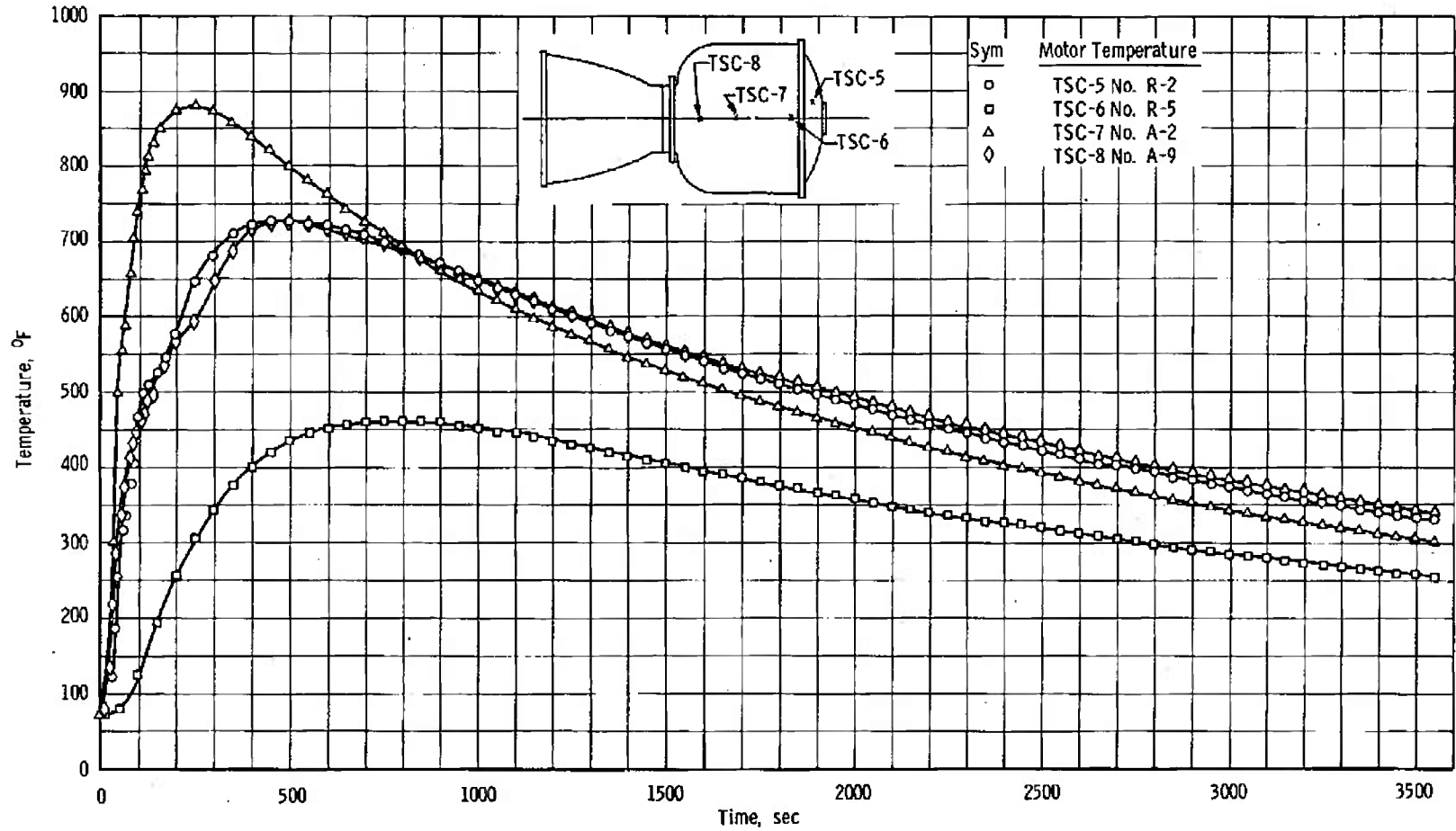

b. TSC-5 through -8

Fig. 11 Continued

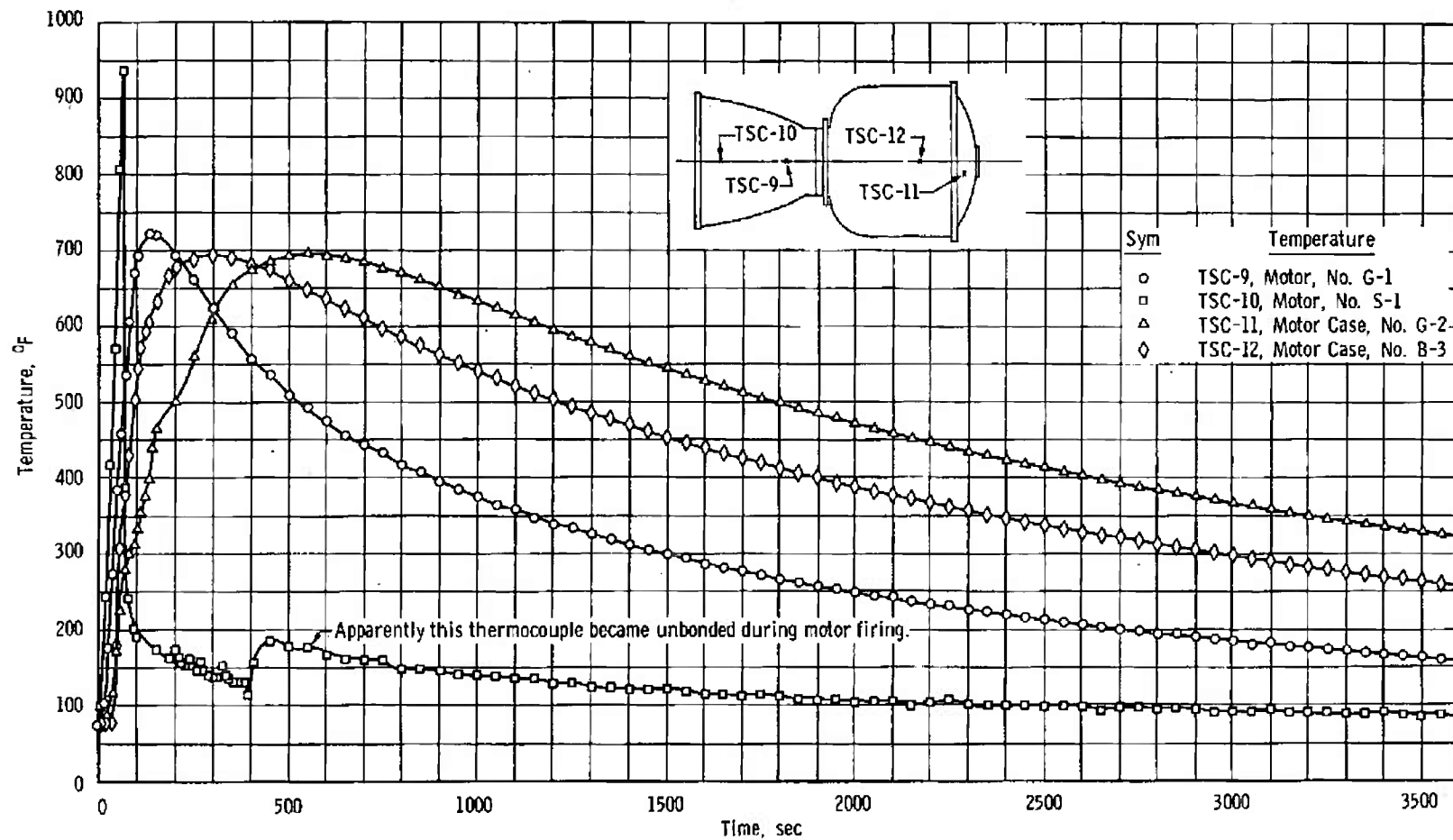

c. TSC-9 through -12

Fig. 11 Continued

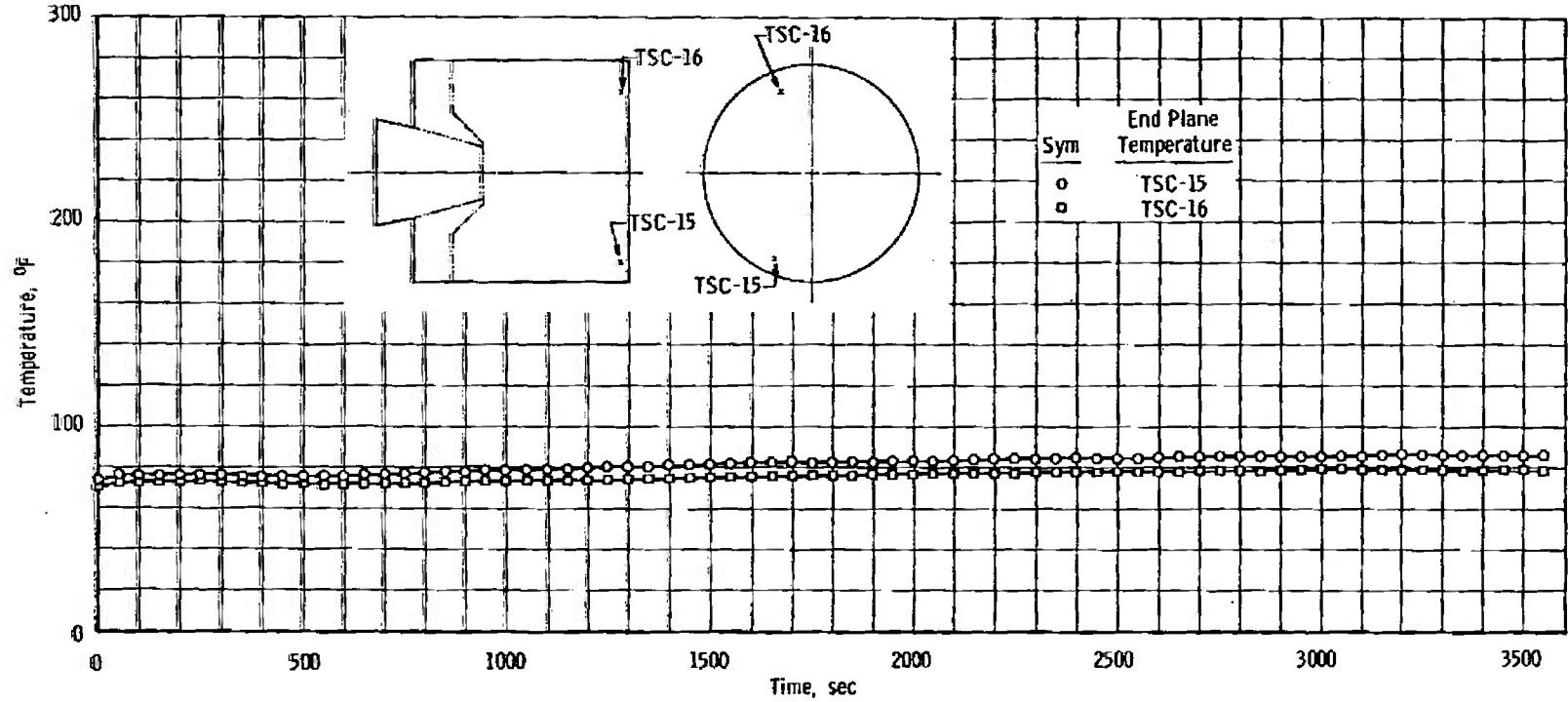

d. TSC-15 through -16

Fig. 11 Continued

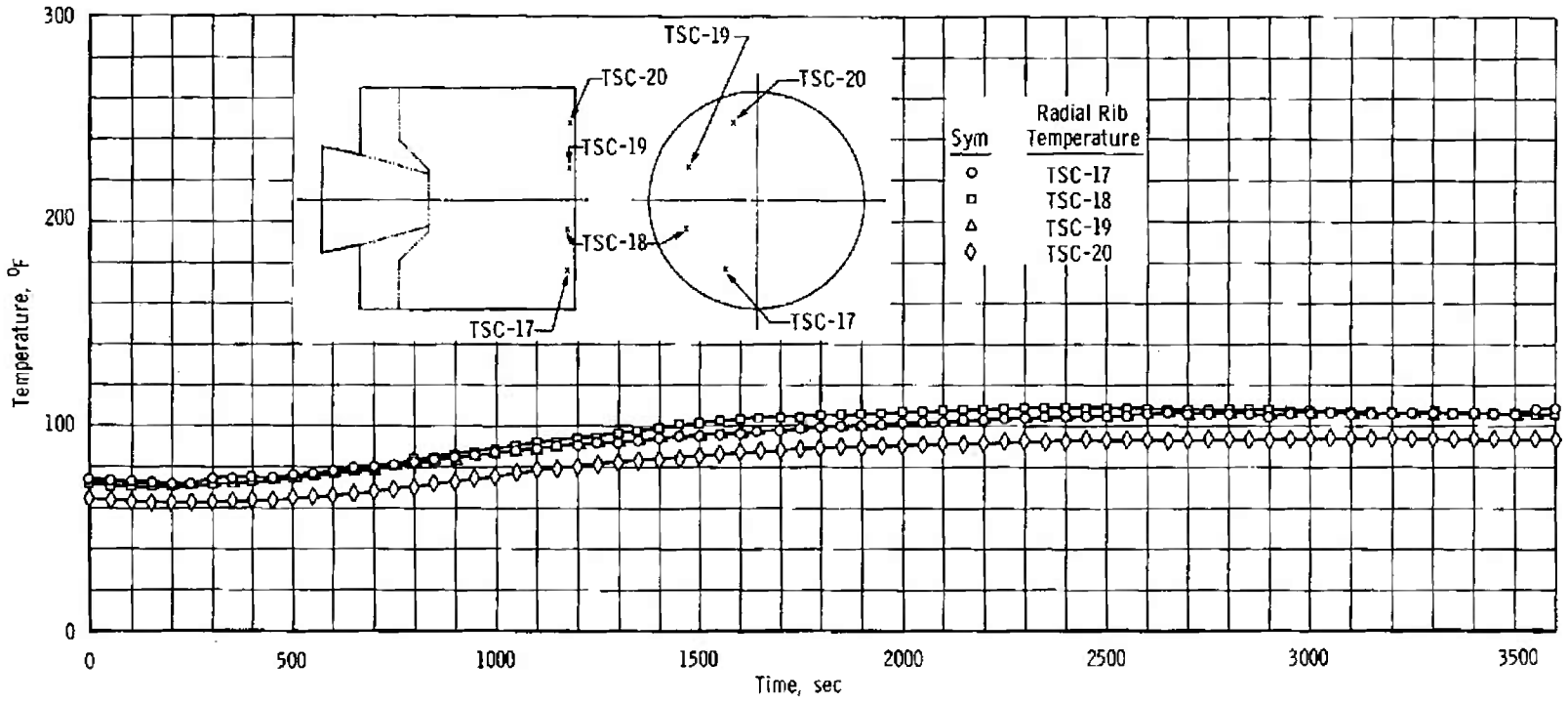

e. TSC-17 through -20
 Fig. 11 Continued

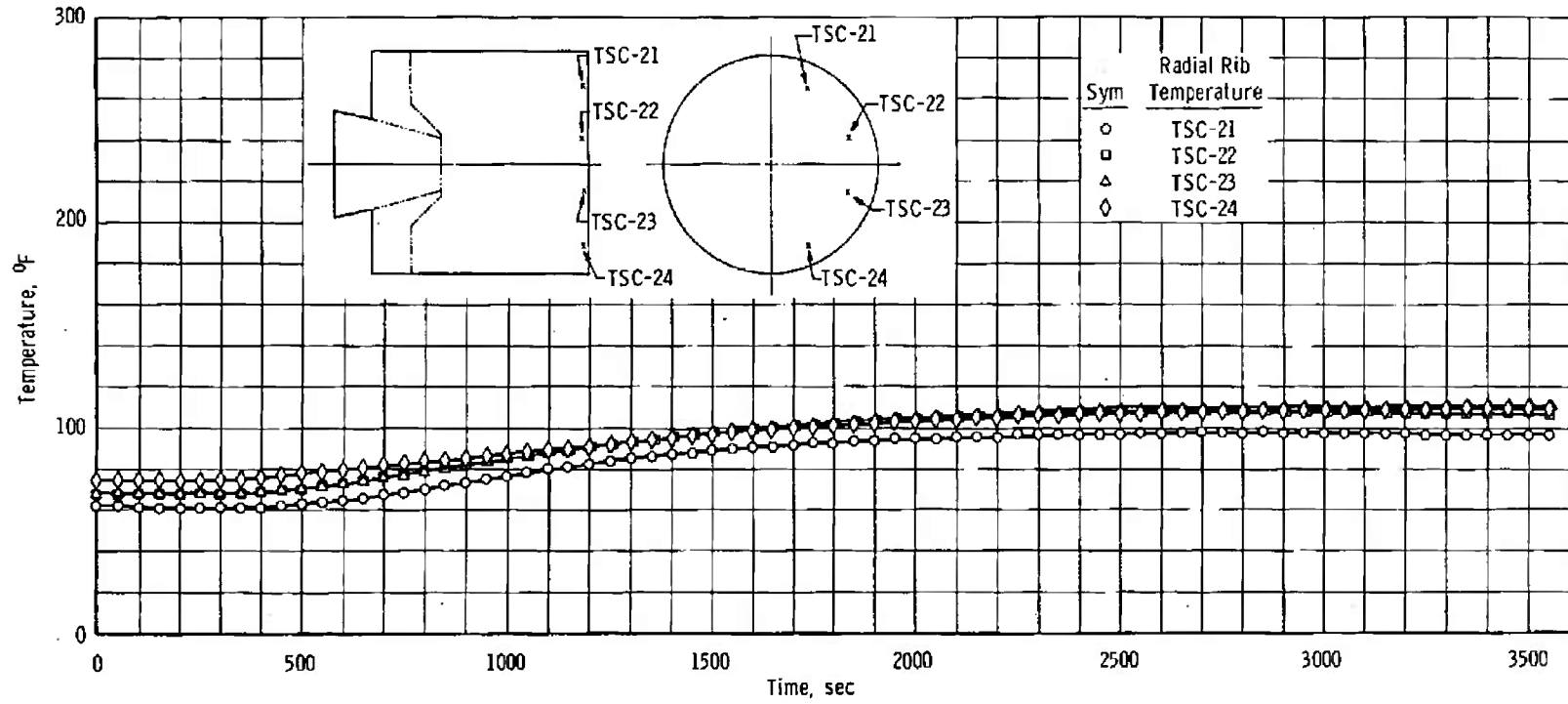

f. TSC-21 through -24

Fig. 11 Continued

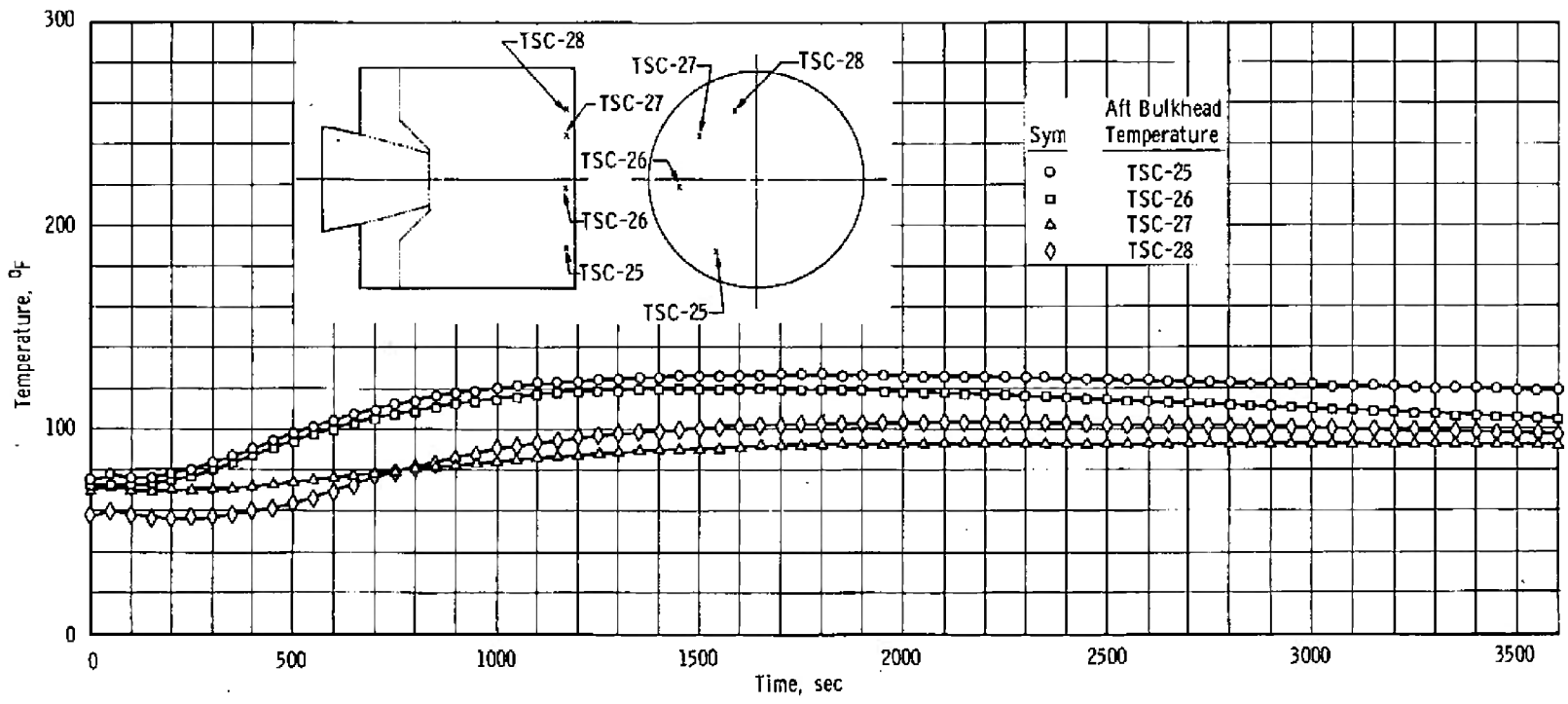

g. TSC-25 through -28
 Fig. 11 Continued

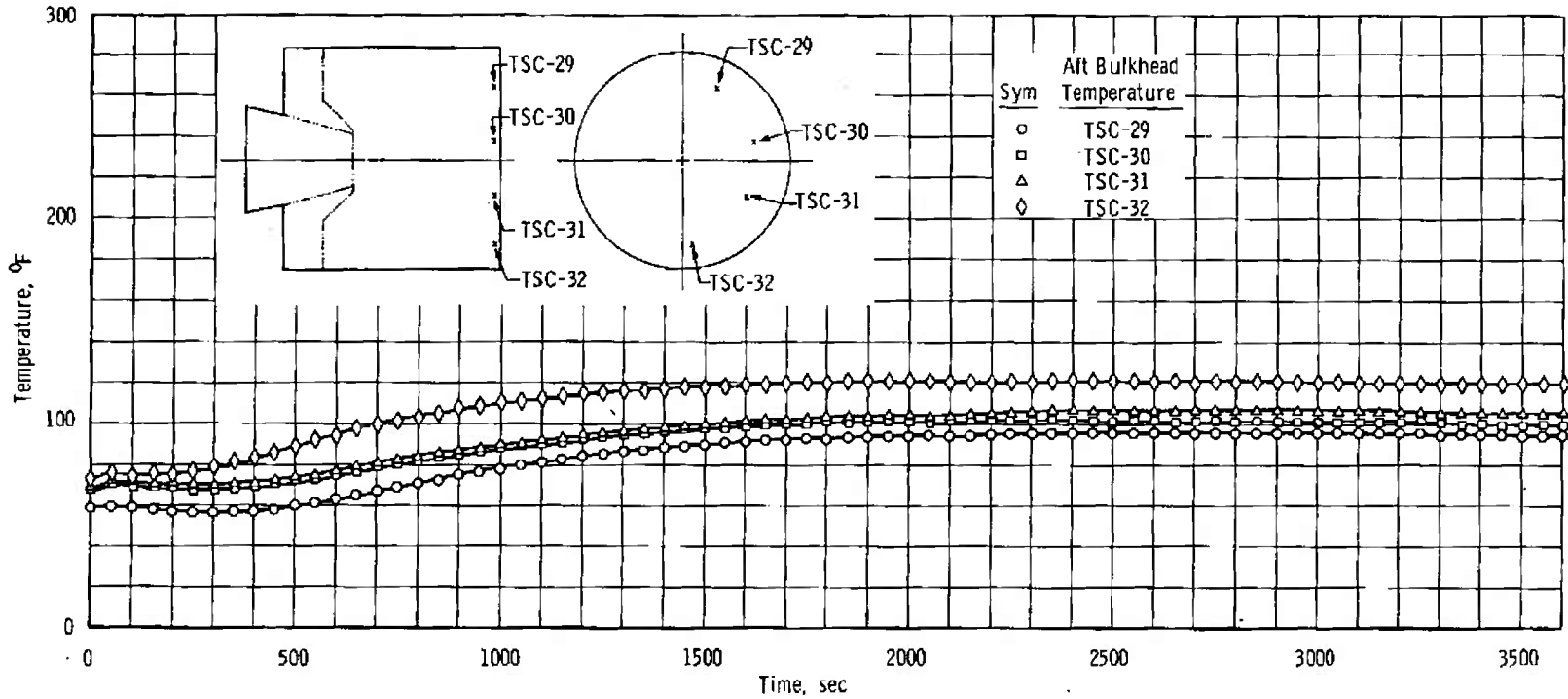

h. TSC-29 through -32
Fig. 11 Continued

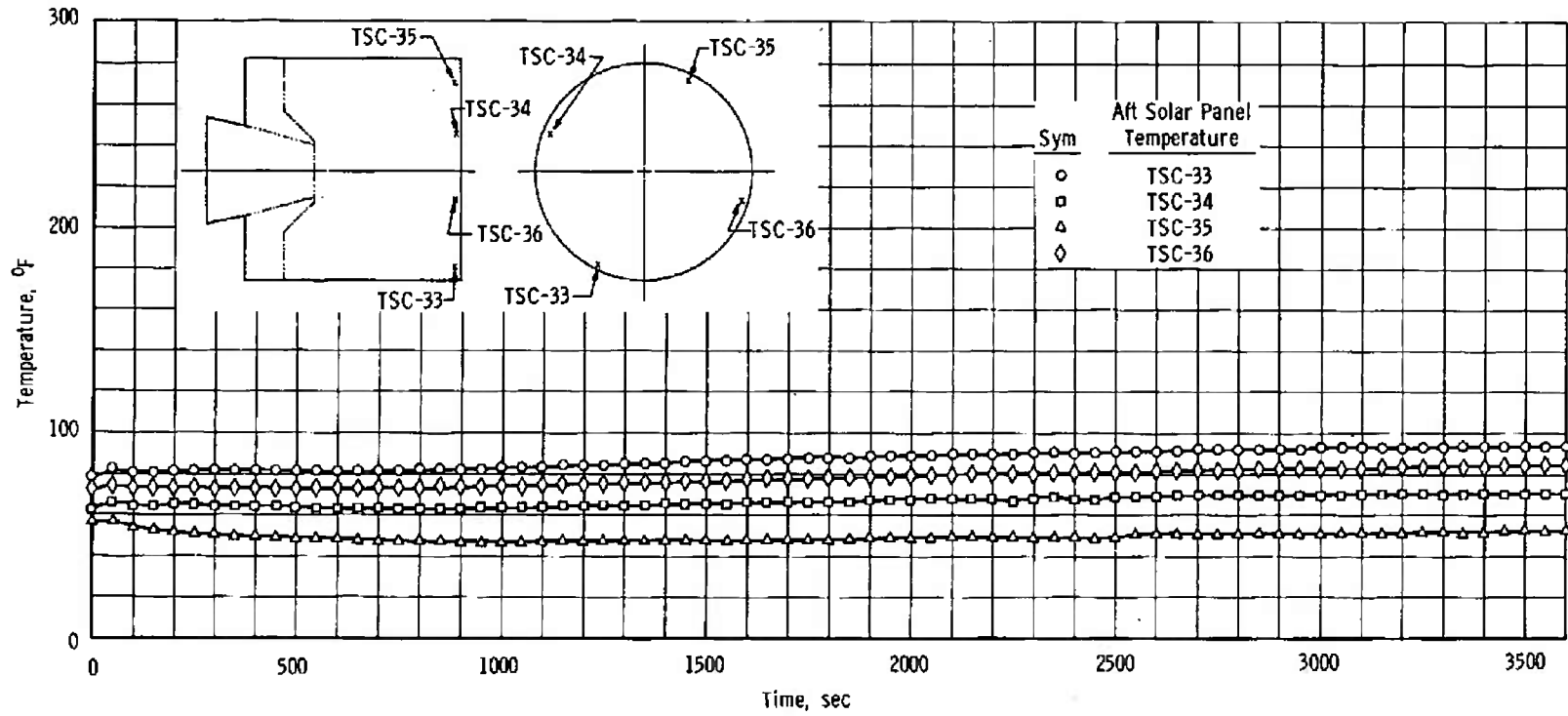

i. TSC-33 through -36

Fig. 11 Continued

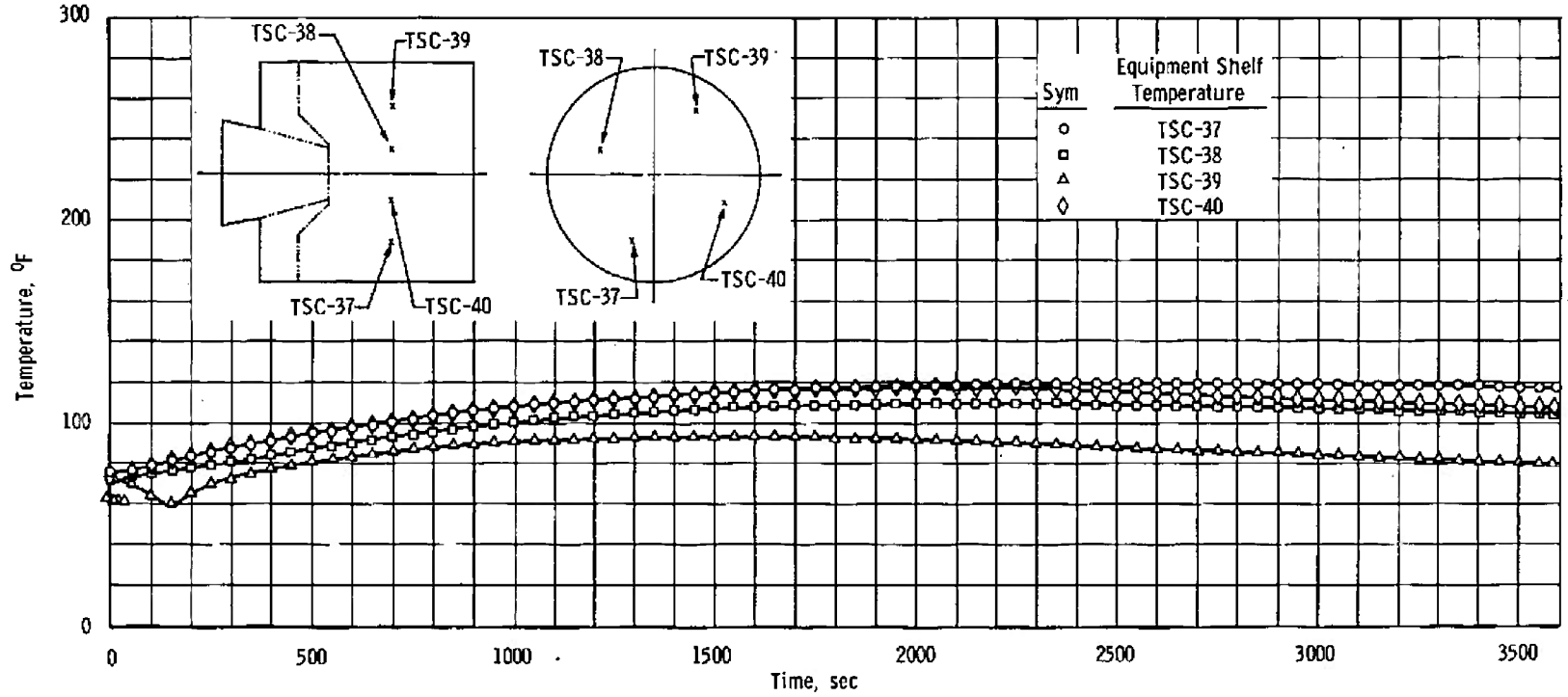

j. TSC-37 through -40
Fig. 11 Continued

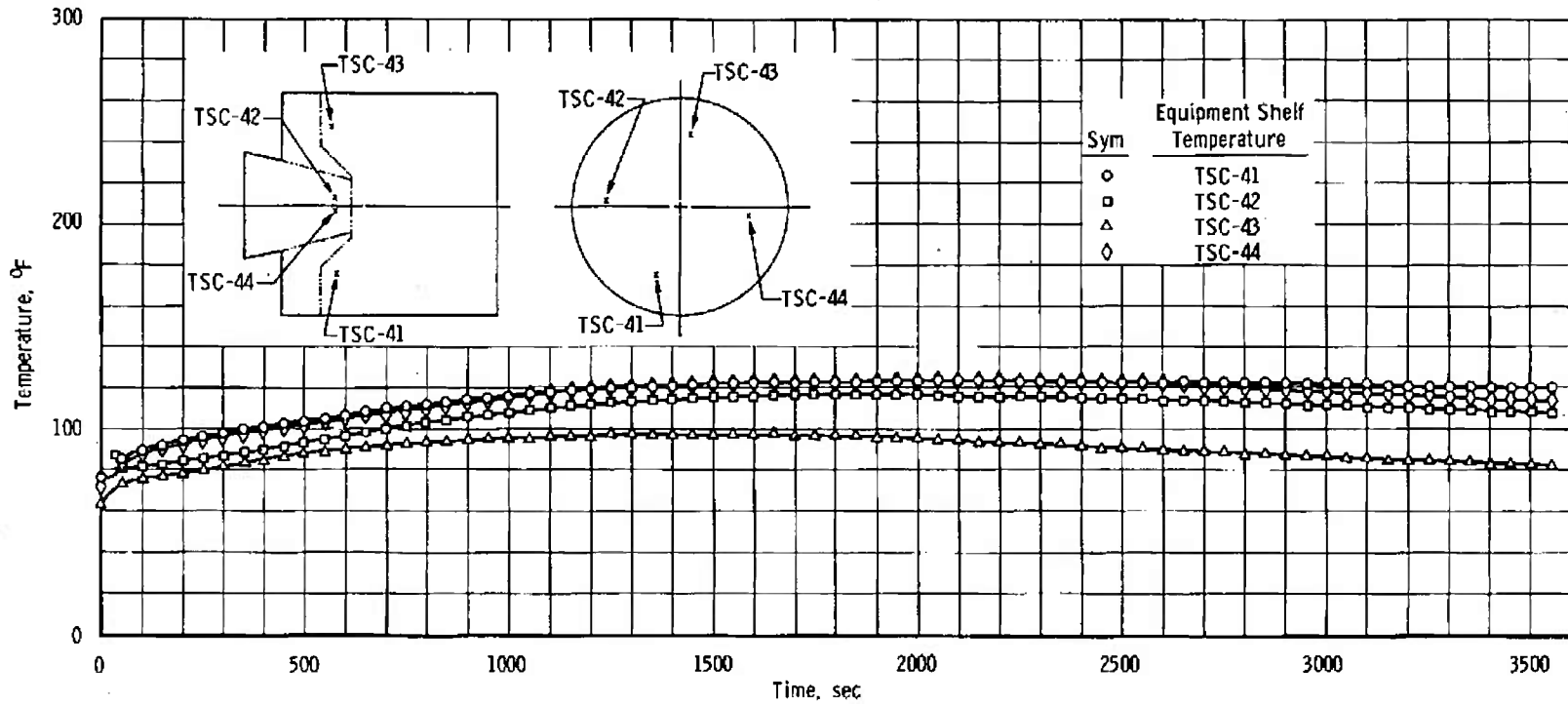

k. TSC-41 through -44

Fig. 11 Continued

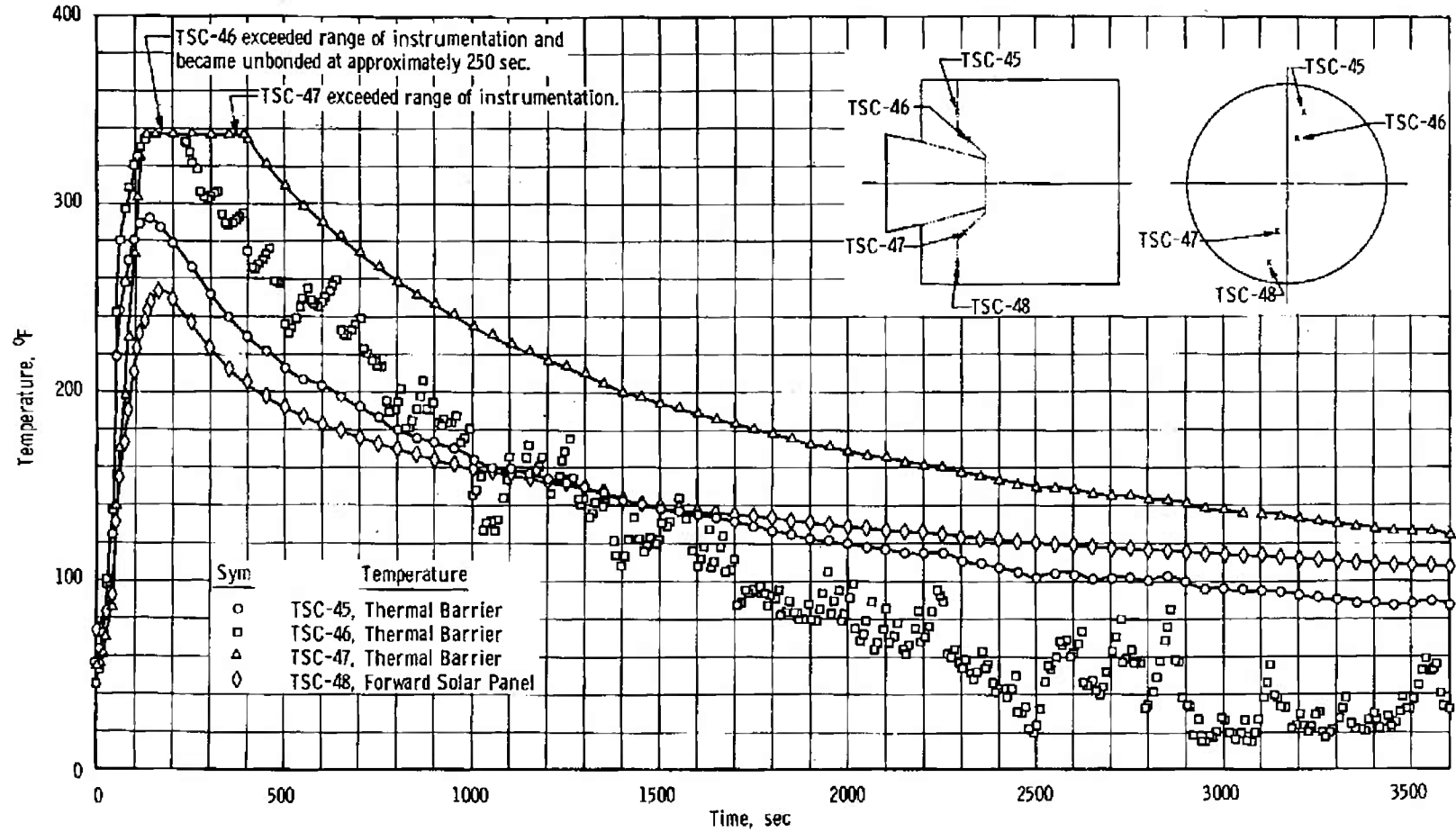

I. TSC-45 through -48

Fig. 11 Continued

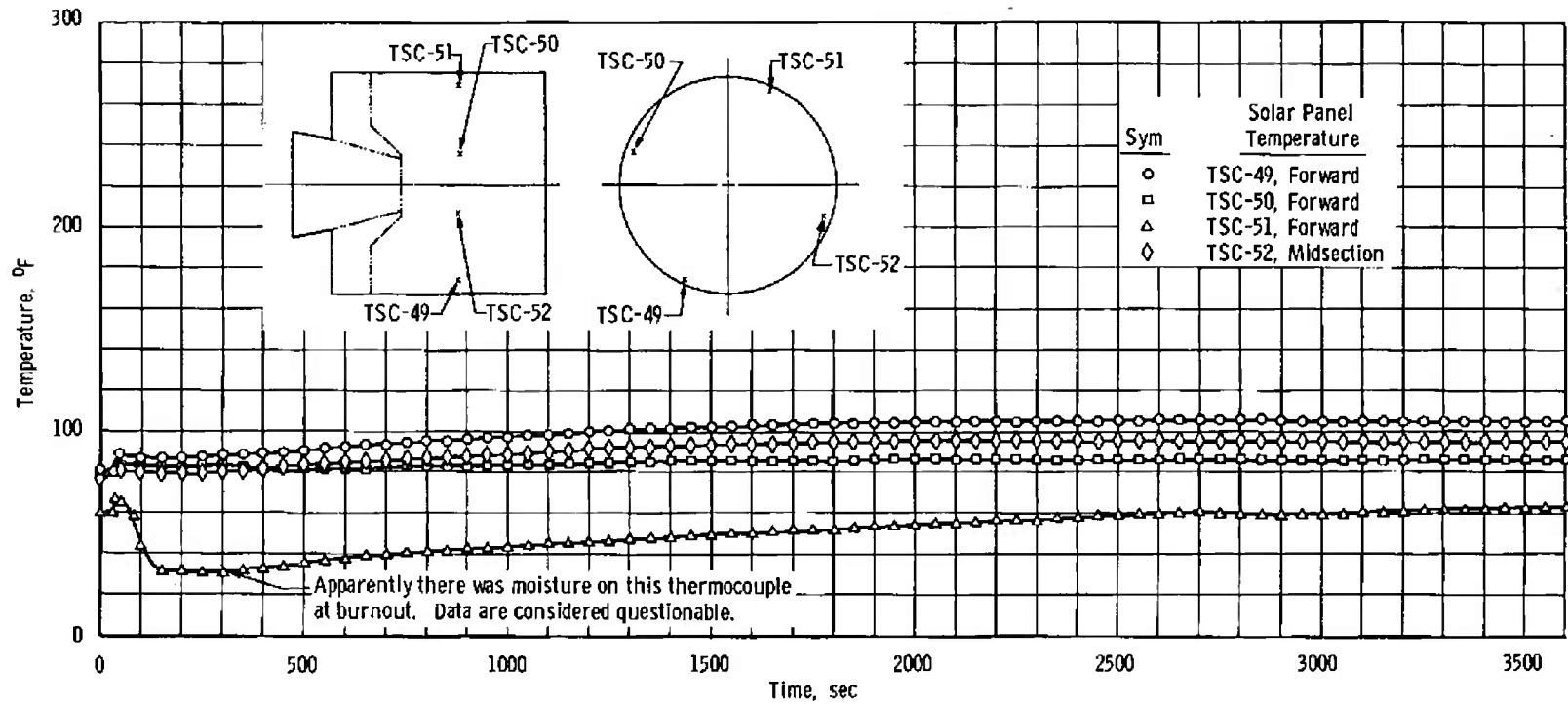

m. TSC-49 through -52
Fig. 11 Continued

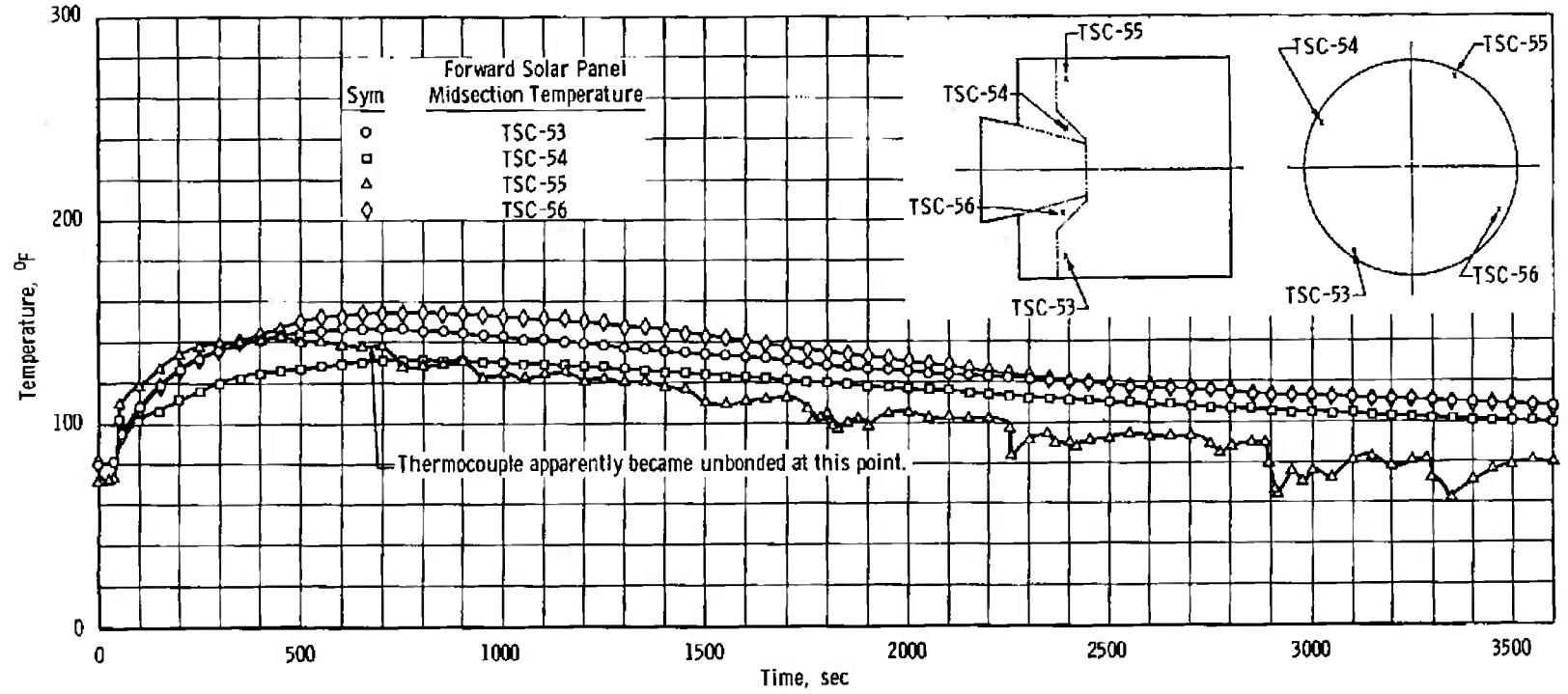

n. TSC-53 through -56

Fig. 11 Continued

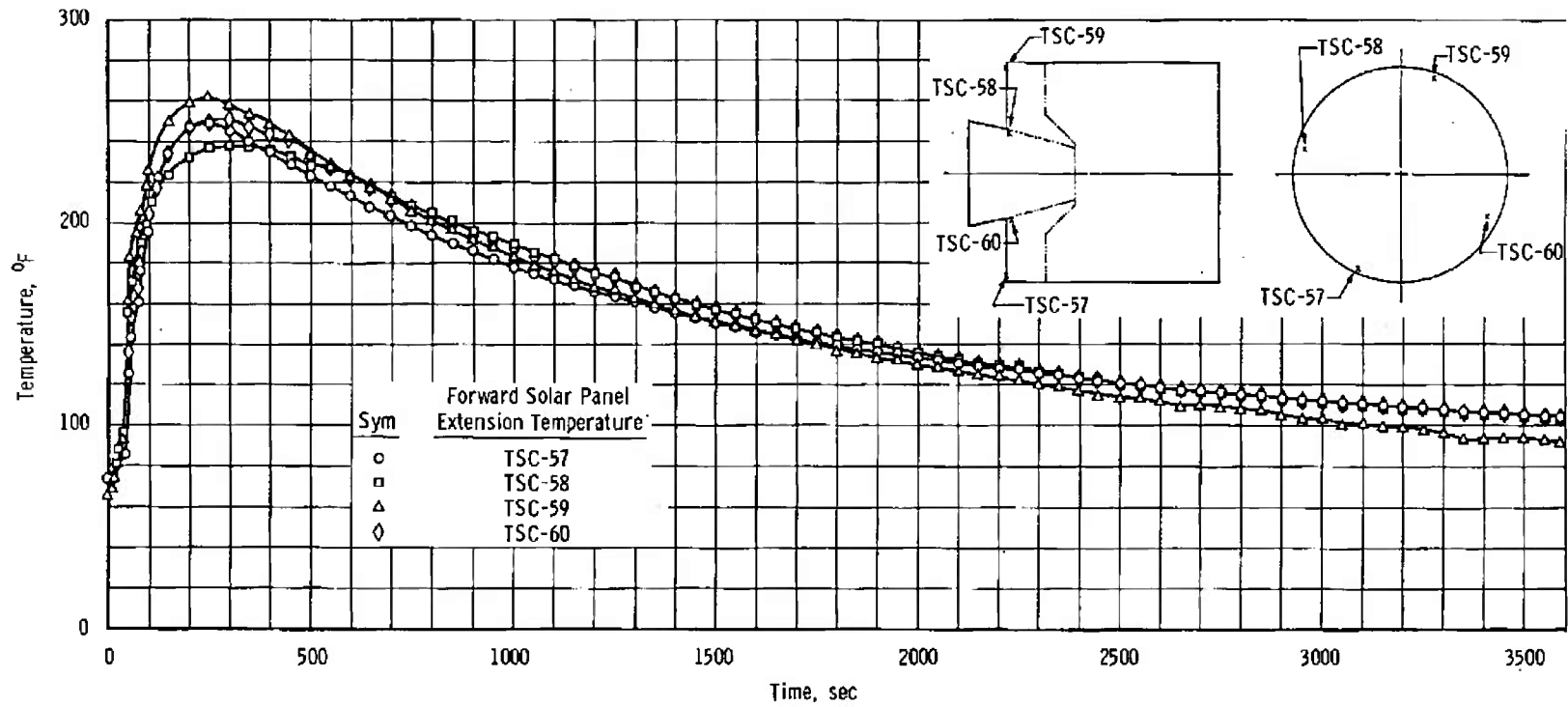

o. TSC-57 through -60

Fig. 11 Continued

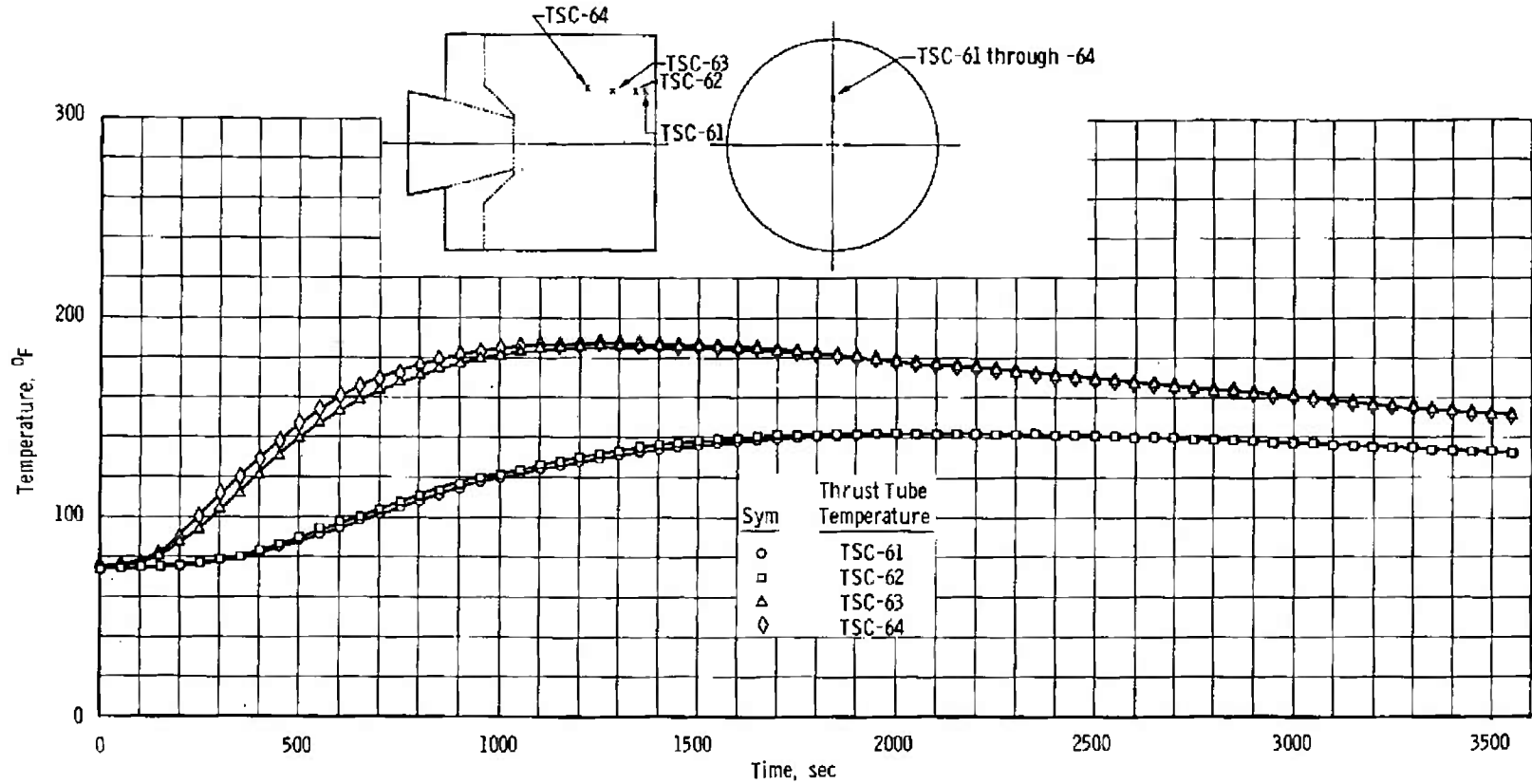

p. TSC-61 through -64
 Fig. 11 Continued

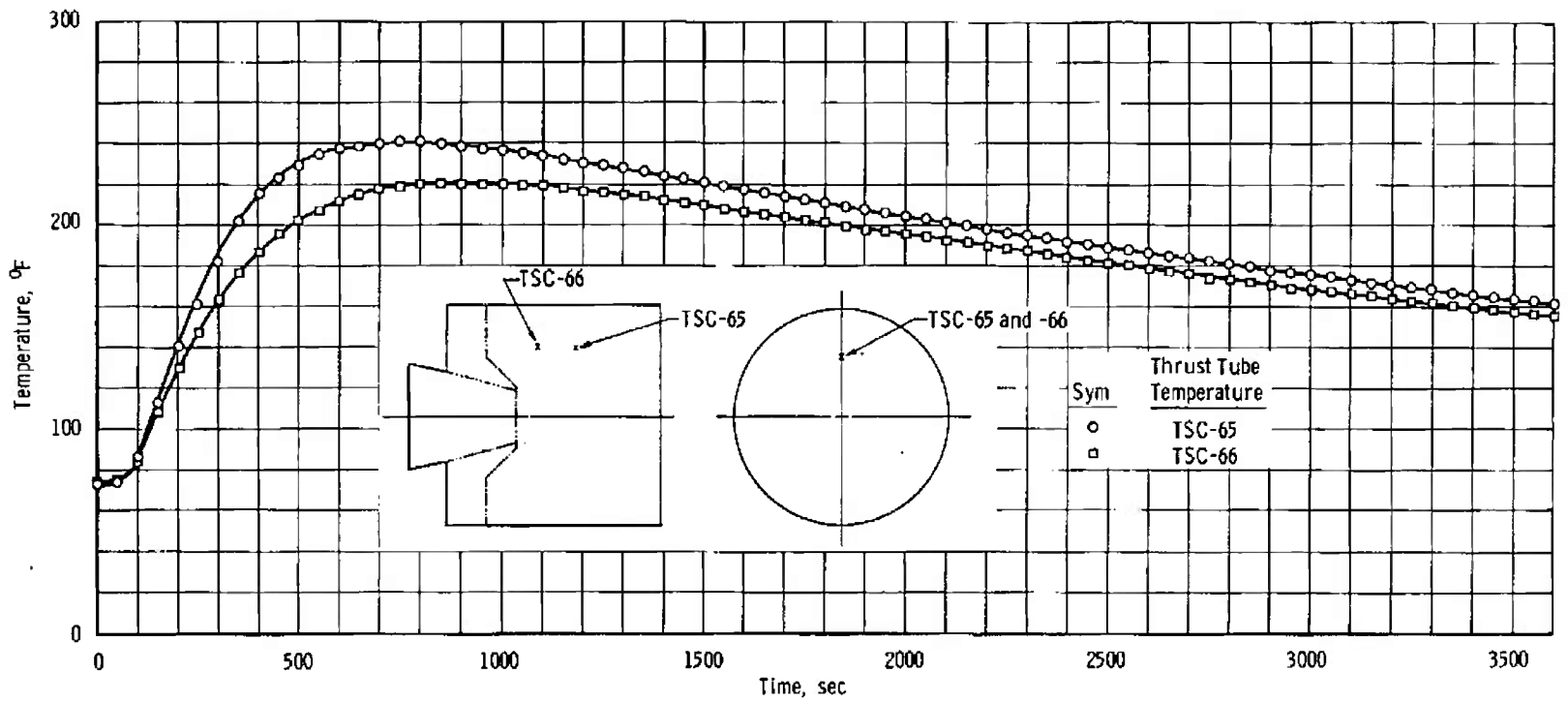

q. TSC-65 through -66
 Fig. 11 Continued

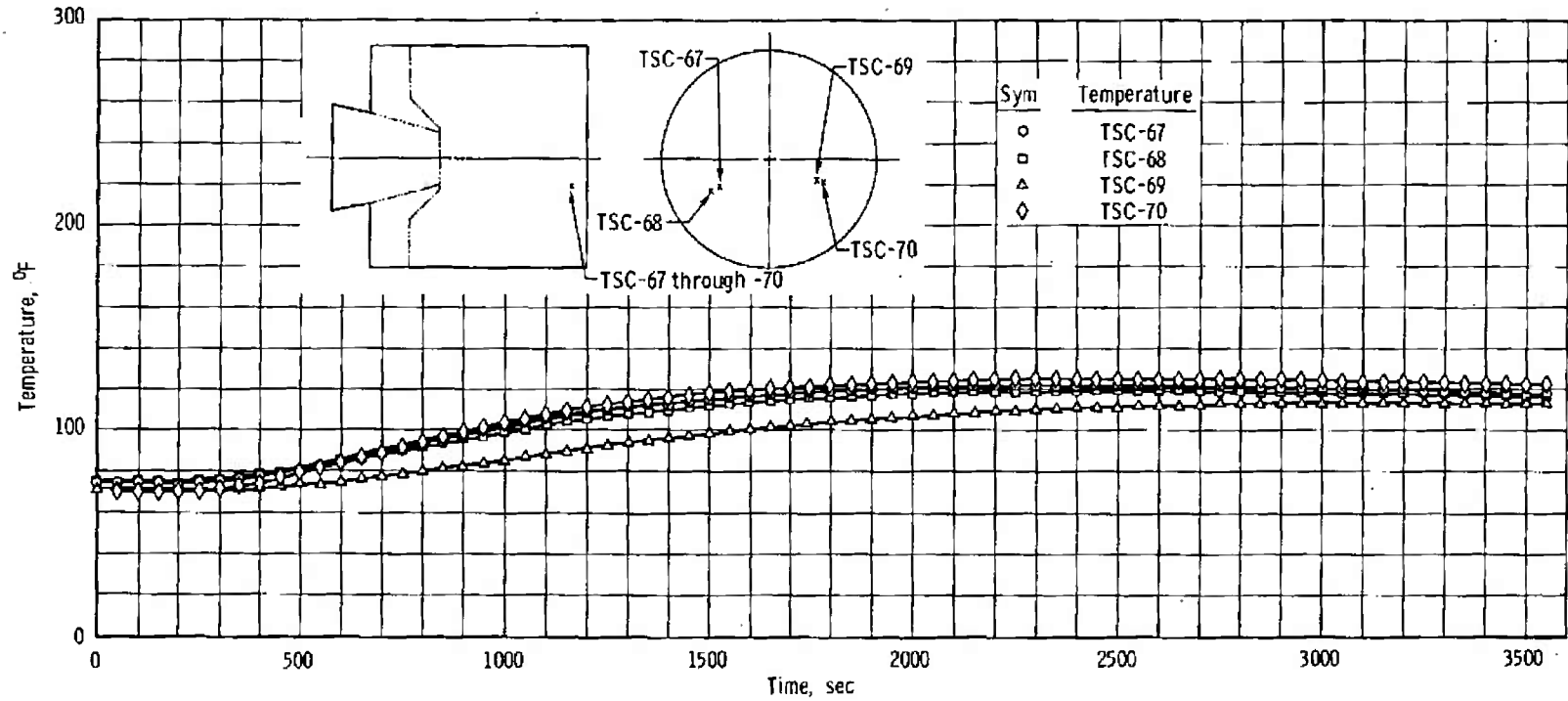

r. TSC-67 through -70

Fig. 11 Continued

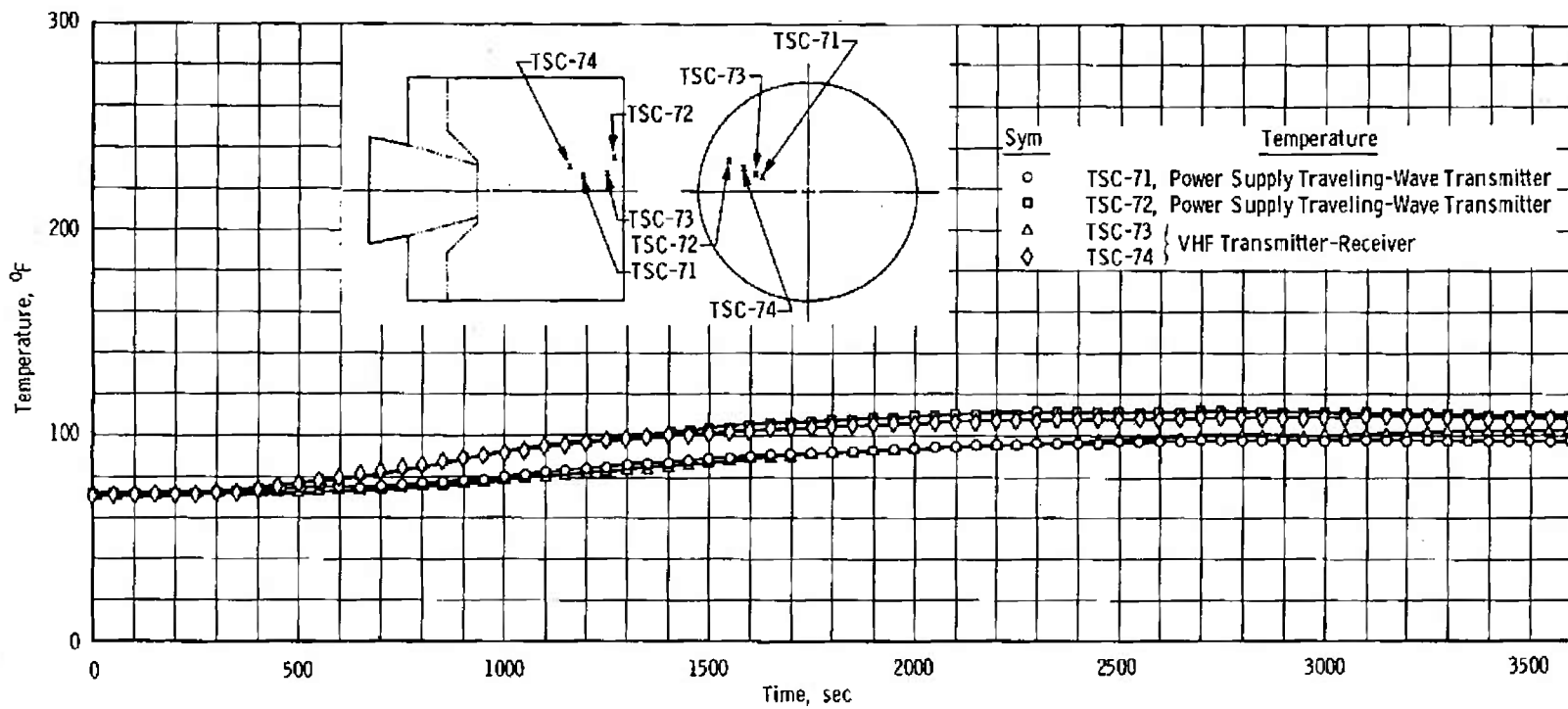

s. TSC-71 through -74
 Fig. 11 Continued

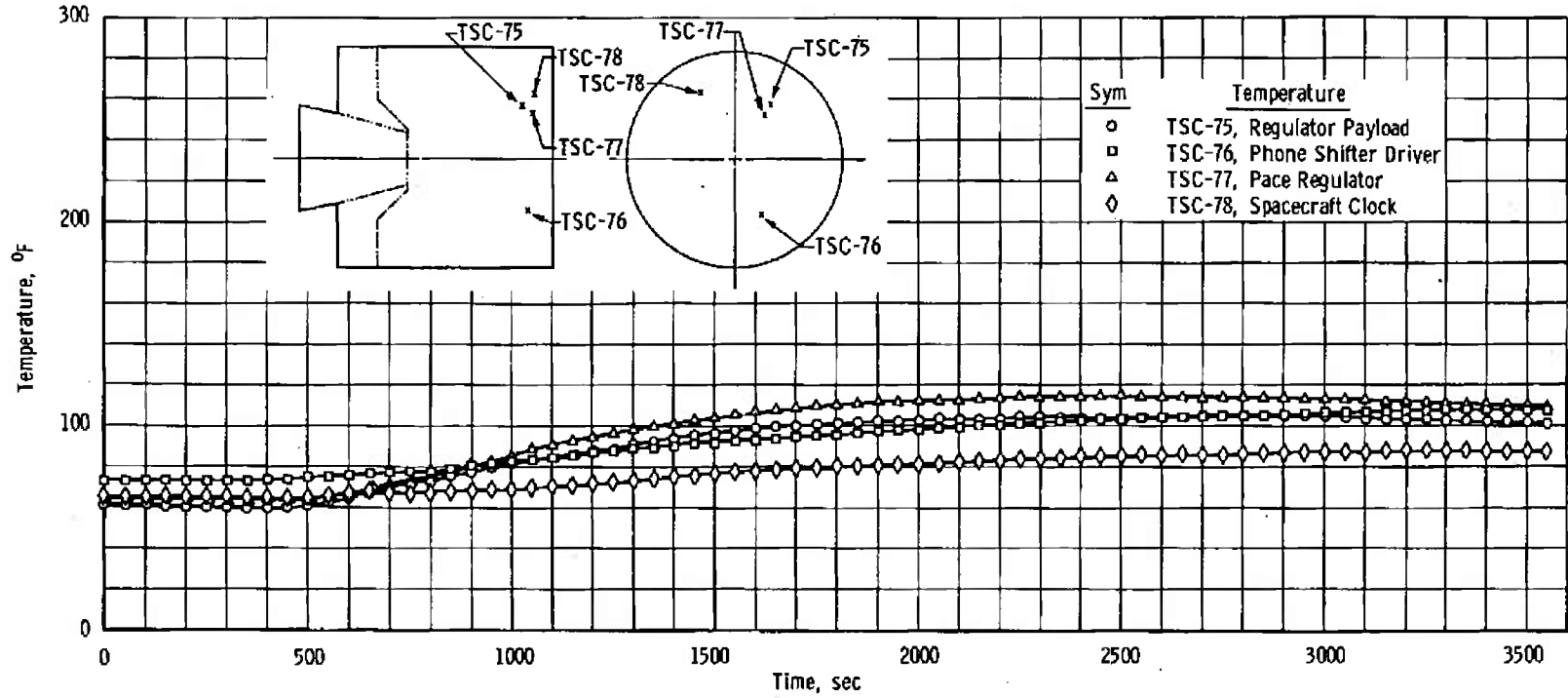

1. TSC-75 through -78
Fig. 11 Continued

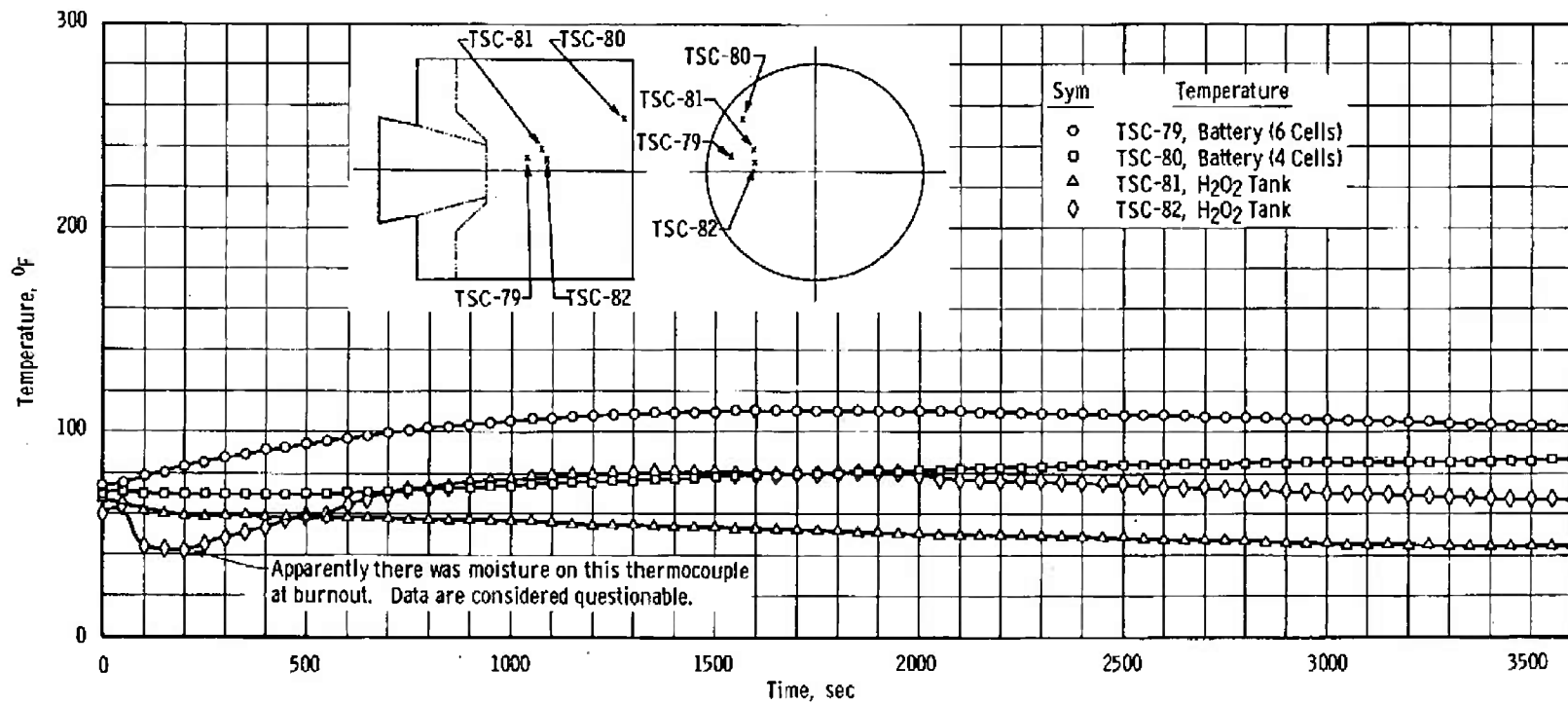

v. TSC-79 through -82

Fig. 11 Continued

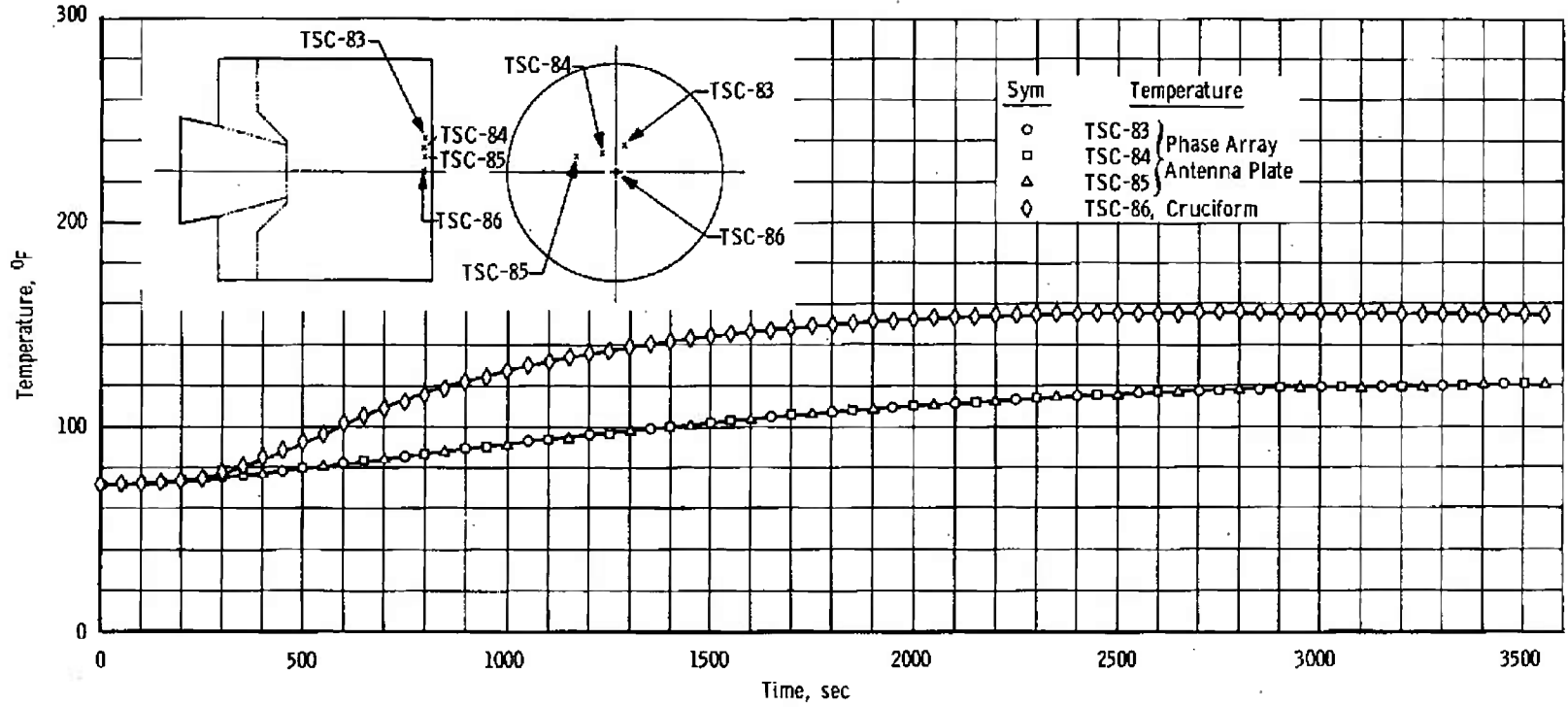

v. TSC-83 through -86
Fig. 11 Continued

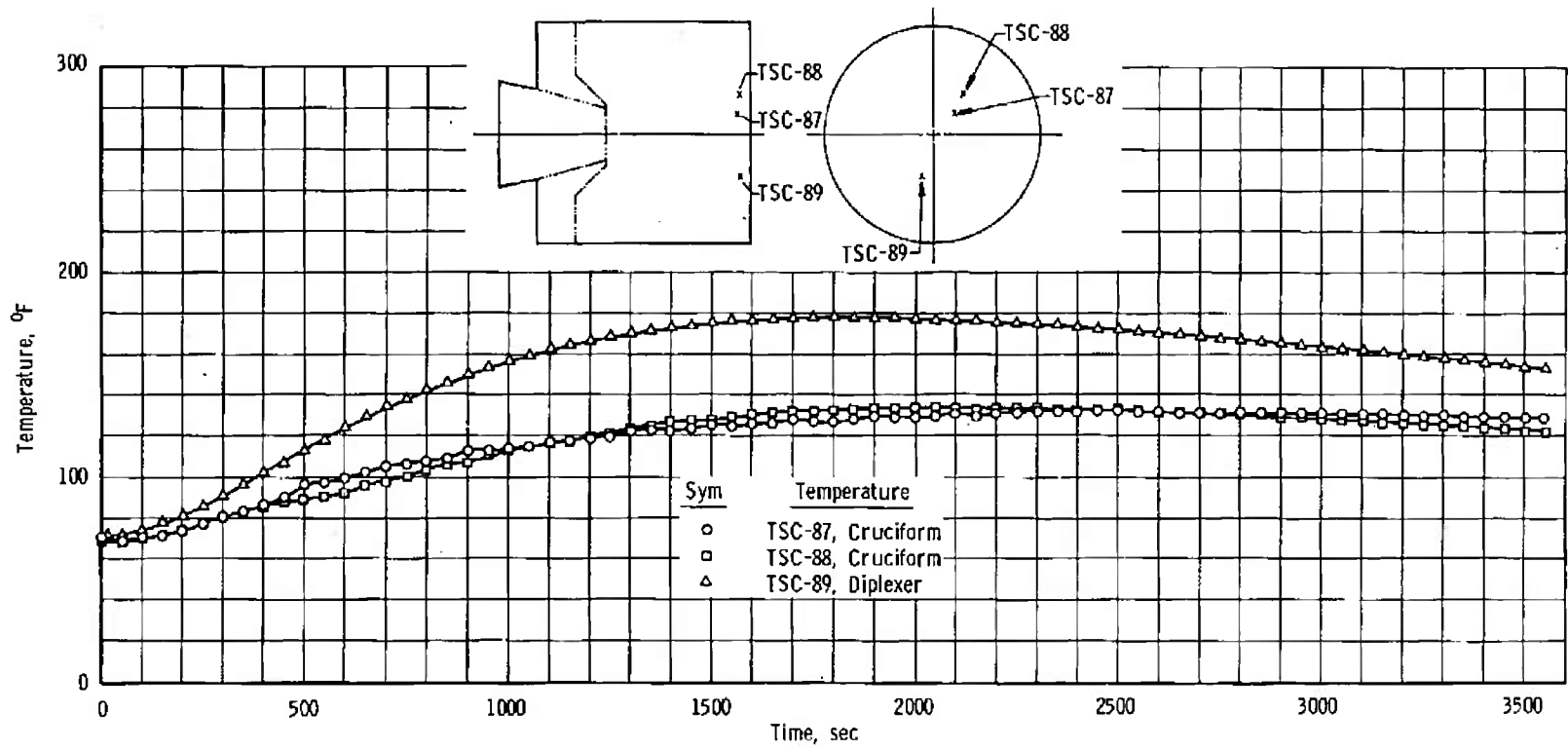

w. TSC-87 through -89

Fig. 11 Continued

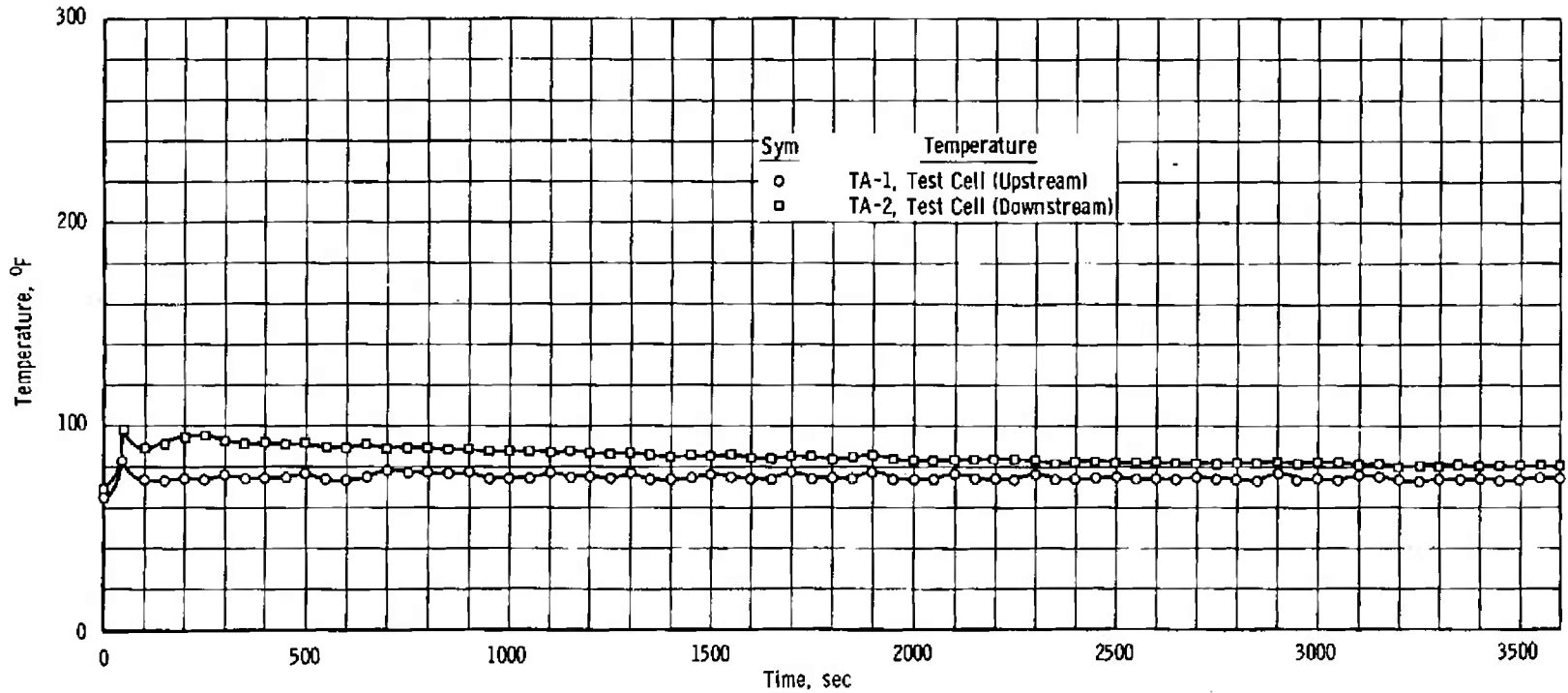

x. TA-1 and -2
Fig. 11 Concluded

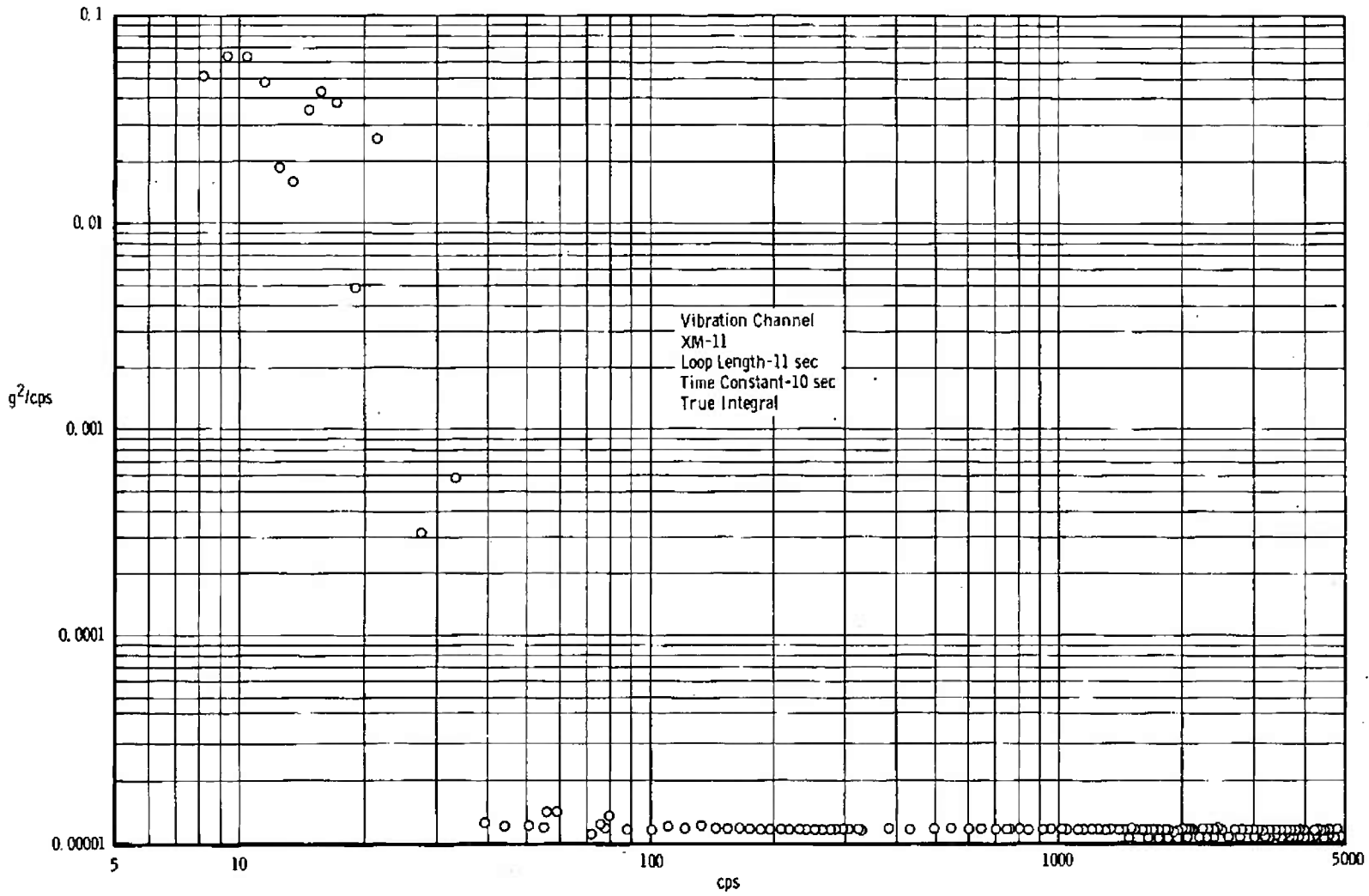

Fig. 12 Power Spectral Density

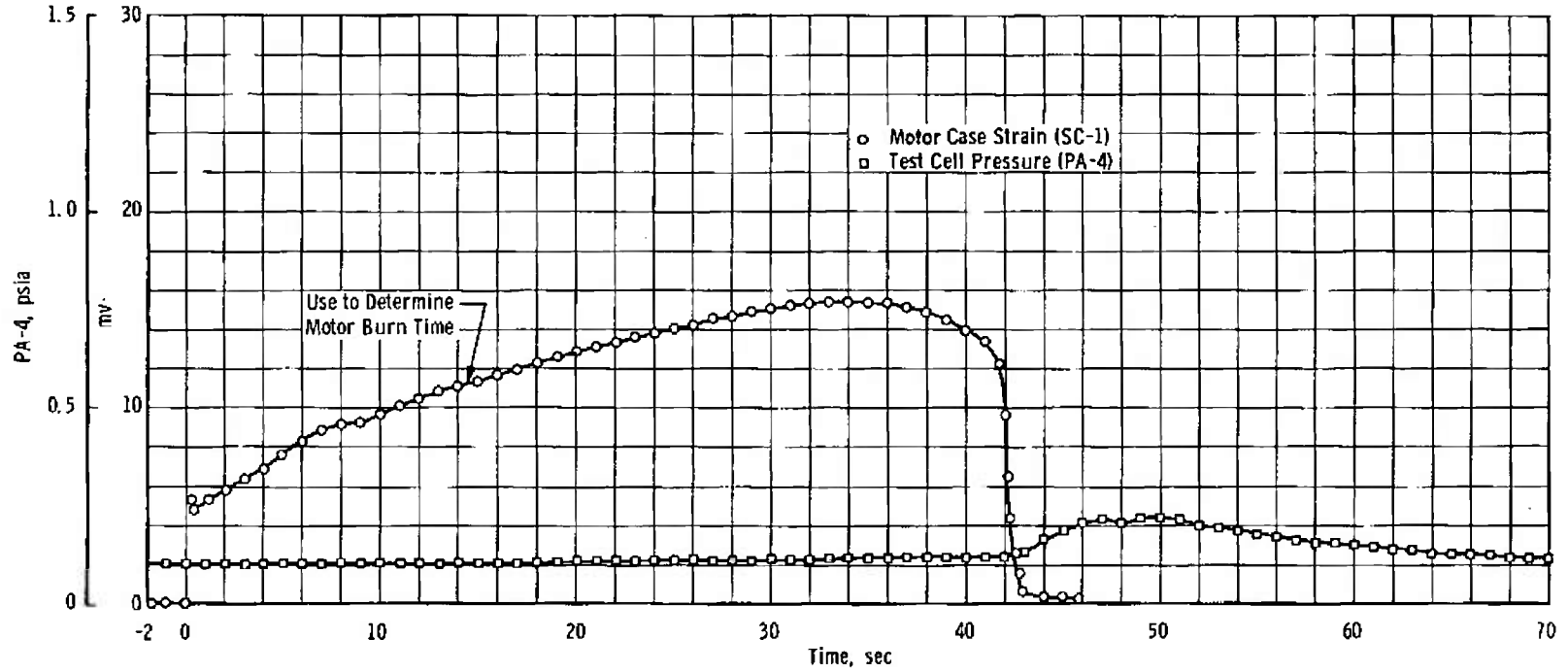

Fig. 13 Motor Case Strain and Test Cell Pressure Plots

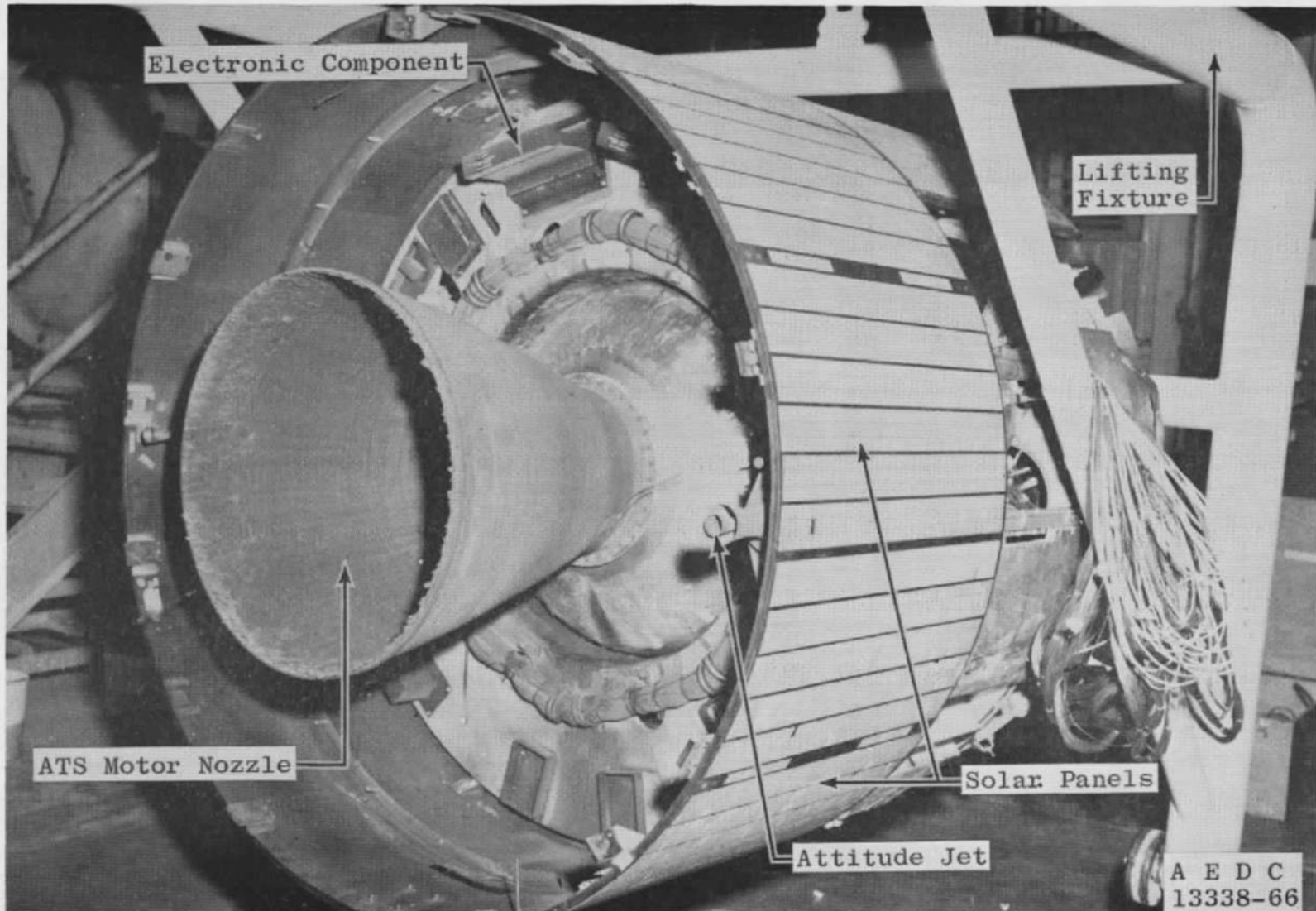

Fig. 14 Post-Firing View of ATS with Thermal Barrier Removed

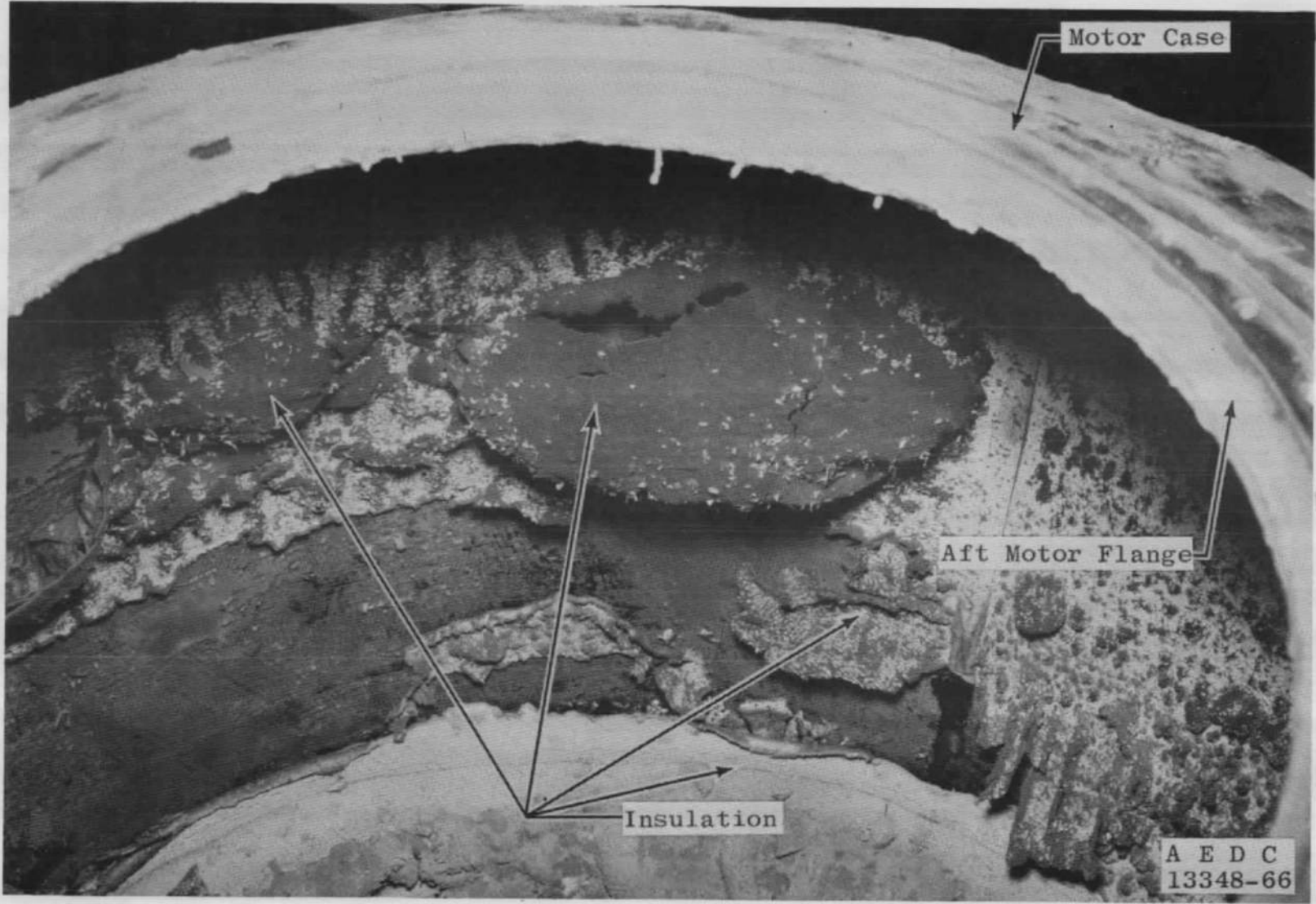
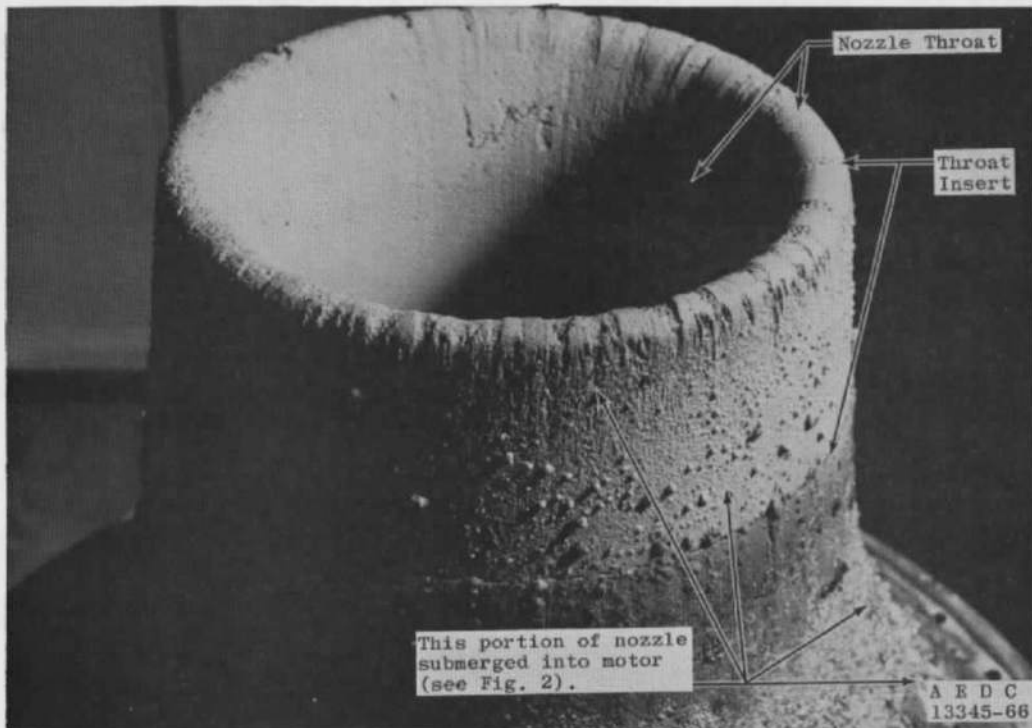
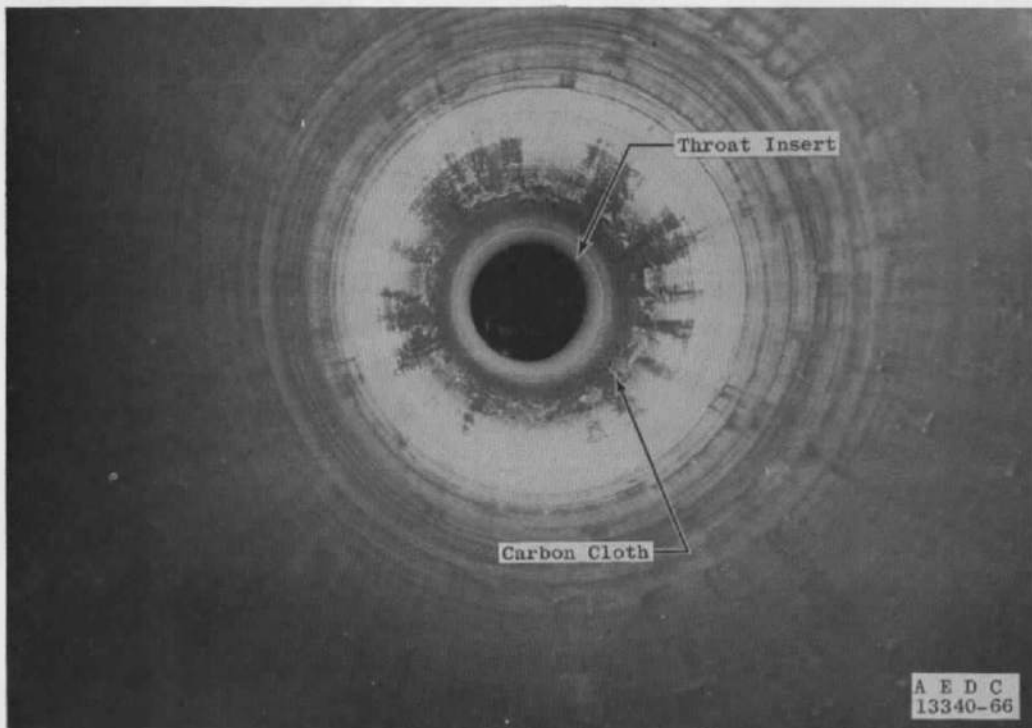

Fig. 15 Interior of Apogee Motor with Nozzle Removed



a. Throat Upstream Entrance



b. Throat Downstream Exit

Fig. 16 Nozzle Post-Firing Condition

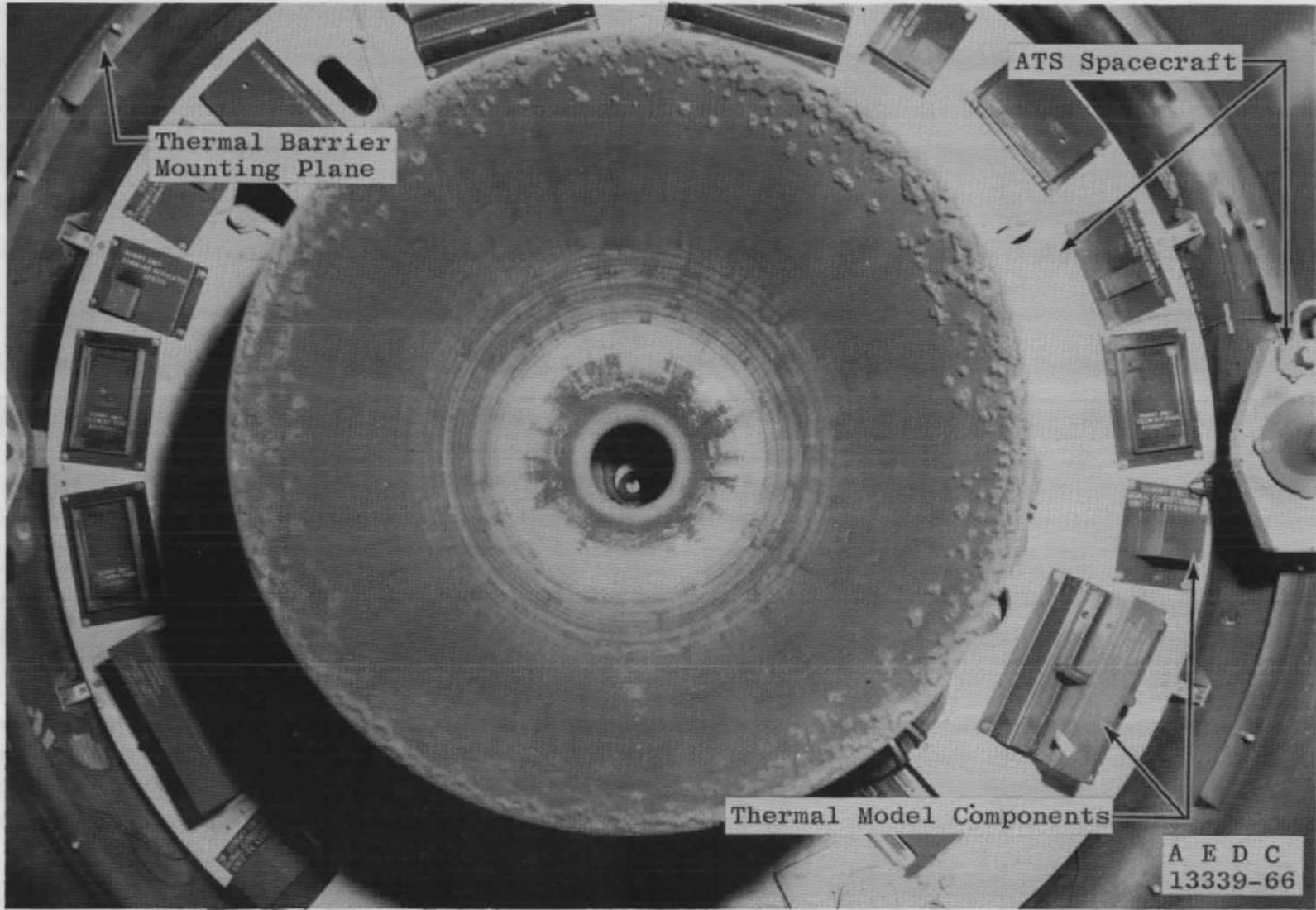
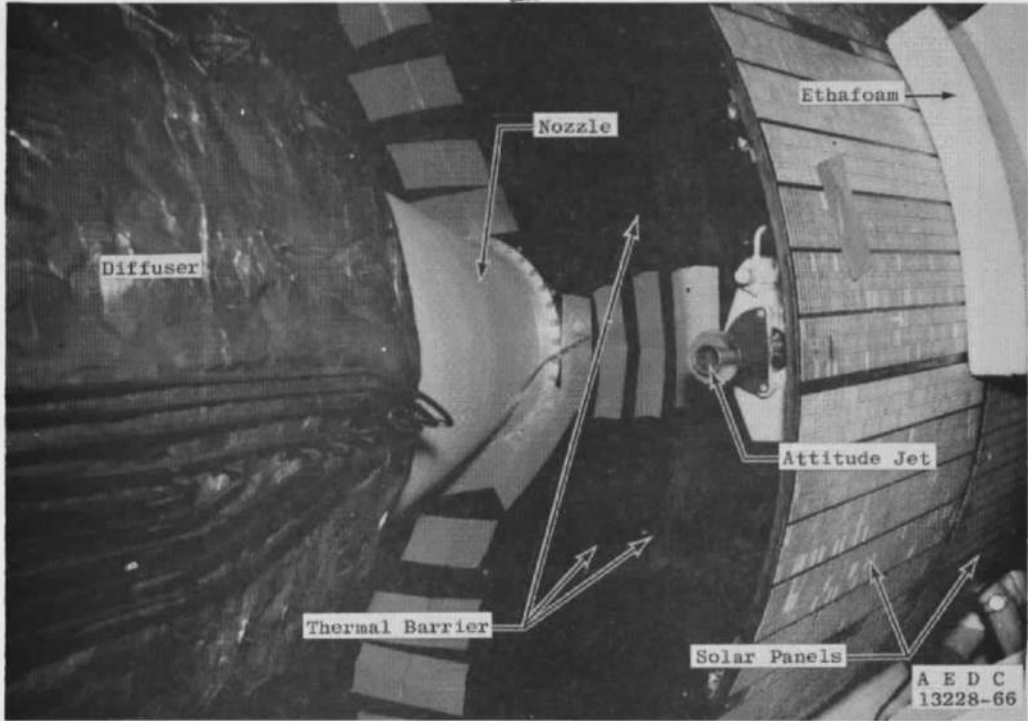
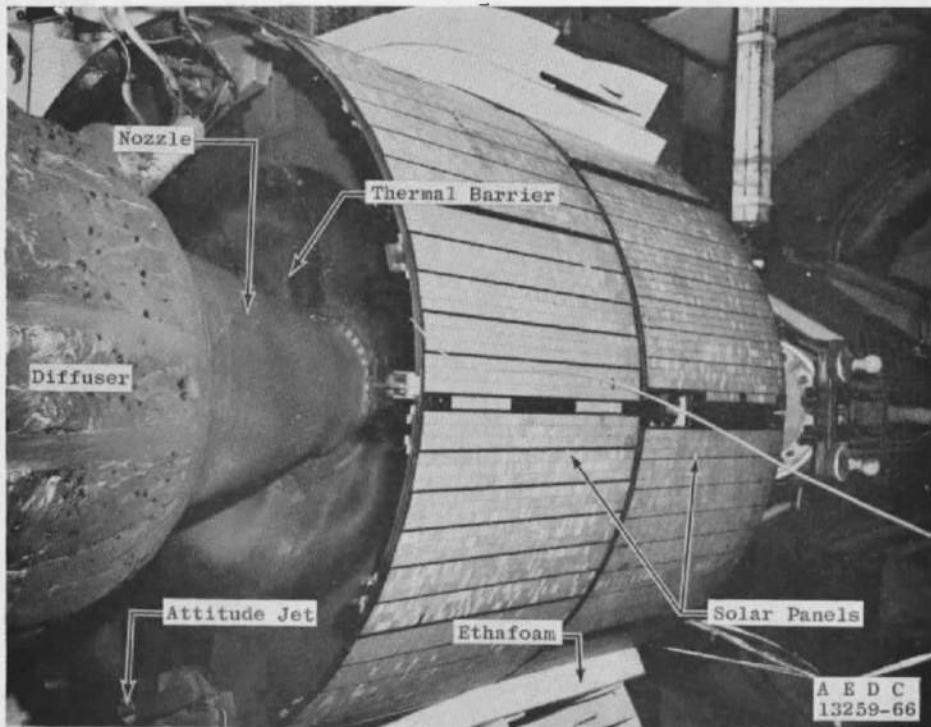

Fig. 17 Post-Firing Head-On View of ATS with Thermal Barrier Removed



a. Pre-Firing



b. Post-Firing

Fig. 18 Solar Panel Comparison

TABLE I
PHYSICAL CHARACTERISTICS OF THE ATS APOGEE MOTOR

Test Number	KB1603-01
Motor Serial Number	JPL-SR-28-3
Motor Designation	ATS Apogee Motor
Total Weight (As Tested)	891.78 lb
Motor Weight Difference (Based on Pre- and Post-Firing Weight)	764.08 lb
Inert Weight (Motor Only)	79.0 lb
Diameter	28 in.
Length (Head End to Nozzle Exit, Including S/A Device)	54 in.
Explosive Classification	ICC Class B
Storage Temperature Limits	20 to 130°F
Storage Life	1 yr at 80°F
Physical Measurements	
Nozzle	
Throat Area	
Pre-Firing	13.11 in. ²
Post-Firing	13.33 in. ²
Average	13.22 in. ²
Exit Area	
Pre-Firing	456.55 in. ²
Post-Firing	455.56 in. ²
Average	456.05 in. ²
Erosion	
Throat Area	+1.67 percent
Exit Area	-0.21 percent
Area Ratio	
Pre-Firing	34.83
Post-Firing	34.19
Average	34.51
Center of Gravity (Manufacturer Supplied)	
Pre-Firing	11.4 in. Aft of Attach Plane
Post-Firing	20.7 in. Aft of Attach Plane

TABLE II
SUMMARY OF INSTRUMENTATION

<u>Parameter Symbol</u>	<u>Parameter</u>	<u>Location</u>
PA-3	Cell Pressure	East Side Test Cell
PA-4	Cell Pressure	East Side Test Cell
PA-5	Cell Pressure	East Side Test Cell
SC-1	Strain Gage	On Motor Case
SC-2	Strain Gage	On Motor Case
SC-3	Strain Gage	On Motor Case
SC-4	Strain Gage	On Motor Case
XM-1	Vibration	ION Eng A-1
XM-2	Vibration	H ₂ O ₂ SB QII
XM-3	Vibration	H ₂ O ₂ , Sub. System BQIV
XM-4	Vibration	Spin Scan Camera
XM-5	Vibration	Nutation Experiment
XM-6	Vibration	Transponder
XM-7	Vibration	VHF Transponder
XM-8	Vibration	EME Package
XM-9	Vibration	Rib No. 8 $\theta = 337.5$ deg
XM-10	Vibration	Rib No. 5 $\theta = 202.5$ deg
XM-11	Vibration	Spin-Up Tank Quadrant II
XM-12	Vibration	Thrust Stand
XM-13	Vibration	Forward Shelf-Mount Electronics, Quadrant I
XM-14	Vibration	Forward Battery Pack
XM-15	Vibration	Motor Mounts $\theta = 0$ deg
XM-16	Vibration	Motor Mounts $\theta = 202.5$ deg
XM-17	Vibration	Motor Mounts $\theta = 270$ deg
XM-18	Vibration	Motor Mounts $\theta = 292.5$ deg
QR-1	Radiometer 6 deg	At Exhaust Diffuser Inlet
QR-2	Radiometer 60 deg	At Exhaust Diffuser Inlet
TSC-1	Temperature	Antenna Cavity Lid
TSC-2	Temperature	Antenna Cavity Lid
TSC-3	Temperature	Antenna Cavity Lid
TSC-4	Temperature	Antenna Cavity Lid
TSC-5	Motor Temperature R-2	On Motor Case
TSC-6	Motor Temperature R-5	On Motor Case
TSC-7	Motor Temperature A-2	On Motor Case
TSC-8	Motor Temperature A-9	On Motor Case
TSC-9	Motor Temperature C-1	On Motor Case
TSC-10	Motor Temperature S-1	On Motor Case
TSC-11	Temperature, Motor Case G-2	On Motor Case

TABLE II (Continued)

<u>Parameter Symbol</u>	<u>Parameter</u>	<u>Location</u>
TSC-12	Temperature, Motor Case B-3	On Motor Case
TSC-13	Temperature, Motor Case	Deleted
TSC-14	Temperature, Motor Case	Deleted
TSC-15	Temperature	End Plane
TSC-16	Temperature	End Plane
TSC-17	Temperature	Rib (Radial)
TSC-18	Temperature	Rib (Radial)
TSC-19	Temperature	Rib (Radial)
TSC-20	Temperature	Rib (Radial)
TSC-21	Temperature	Rib (Radial)
TSC-22	Temperature	Rib (Radial)
TSC-23	Temperature	Rib (Radial)
TSC-24	Temperature	Rib (Radial)
TSC-25	Temperature	Aft Bulkhead between Ribs
TSC-26	Temperature	Aft Bulkhead between Ribs
TSC-27	Temperature	Aft Bulkhead between Ribs
TSC-28	Temperature	Aft Bulkhead between Ribs
TSC-29	Temperature	Aft Bulkhead between Ribs
TSC-30	Temperature	Aft Bulkhead between Ribs
TSC-31	Temperature	Aft Bulkhead between Ribs
TSC-32	Temperature	Aft Bulkhead between Ribs
TSC-33	Temperature	Aft Solar Panel
TSC-34	Temperature	Aft Solar Panel
TSC-35	Temperature	Aft Solar Panel
TSC-36	Temperature	Aft Solar Panel
TSC-37	Temperature	Equipment Shelf
TSC-38	Temperature	Equipment Shelf
TSC-39	Temperature	Equipment Shelf
TSC-40	Temperature	Equipment Shelf
TSC-41	Temperature	Equipment Shelf
TSC-42	Temperature	Equipment Shelf
TSC-43	Temperature	Equipment Shelf
TSC-44	Temperature	Equipment Shelf
TSC-45	Temperature	Thermal Barrier
TSC-46	Temperature	Thermal Barrier
TSC-47	Temperature	Thermal Barrier
TSC-48	Temperature	Thermal Barrier
TSC-49	Temperature	Forward Solar Panel
TSC-50	Temperature	Forward Solar Panel
TSC-51	Temperature	Forward Solar Panel
TSC-52	Temperature	Forward Solar Panel
TSC-53	Temperature	Forward Solar Panel Midsection
TSC-54	Temperature	Forward Solar Panel Midsection
TSC-55	Temperature	Forward Solar Panel Midsection
TSC-56	Temperature	Forward Solar Panel Midsection
TSC-57	Temperature	Forward Solar Panel Extension
TSC-58	Temperature	Forward Solar Panel Extension

TABLE II (Concluded)

<u>Parameter Symbol</u>	<u>Parameter</u>	<u>Location</u>
TSC-59	Temperature	Forward Solar Panel Extension
TSC-60	Temperature	Forward Solar Panel Extension
TSC-61	Temperature	Thrust Tube
TSC-62	Temperature	Thrust Tube
TSC-63	Temperature	Thrust Tube
TSC-64	Temperature	Thrust Tube
TSC-65	Temperature	Thrust Tube
TSC-66	Temperature	Thrust Tube
TSC-67	Temperature	Traveling-Wave Transmitter
TSC-68	Temperature	Traveling-Wave Transmitter
TSC-69	Temperature	Traveling-Wave Transmitter
TSC-70	Temperature	Traveling-Wave Transmitter
TSC-71	Temperature	Power Supply TWT
TSC-72	Temperature	Power Supply TWT
TSC-73	Temperature	VHF Transmitter-Receiver
TSC-74	Temperature	VHF Transmitter-Receiver
TSC-75	Temperature	Regulator Payload
TSC-76	Temperature	Phone Shifter Driver
TSC-77	Temperature	Pace Regulator
TSC-78	Temperature	Spacecraft Clock
TSC-79	Temperature	Battery 6 Cell
TSC-80	Temperature	Battery 4 Cell
TSC-81	Temperature	H ₂ O ₂ Tank
TSC-82	Temperature	H ₂ O ₂ Tank
TSC-83	Temperature	Phase Array Antenna Plate
TSC-84	Temperature	Phase Array Antenna Plate
TSC-85	Temperature	Phase Array Antenna Plate
TSC-86	Temperature	Cruciform
TSC-87	Temperature	Cruciform
TSC-88	Temperature	Cruciform
TSC-89	Temperature	Diplexer
TSC-90	Temperature	Diplexer
TA-1	Temperature	Test Cell (Upstream)
TA-2	Temperature	Test Cell (Downstream)
V-1	Motor Fire Switch	In Ignition Circuit
V-2	Motor Fire Switch	In Ignition Circuit
I-1	Ignition Circuit	To S/A Squibs
I-2	Ignition Circuit	To S/A Squibs

DOCUMENT CONTROL DATA - R&D

(Security classification of title, body of abstract and indexing annotation must be entered when the overall report is classified)

1. ORIGINATING ACTIVITY (Corporate author) Arnold Engineering Development Center, ARO, Inc., Operating Contractor, Arnold AF Station, Tennessee		2a. REPORT SECURITY CLASSIFICATION UNCLASSIFIED	
		2b. GROUP N/A	
3. REPORT TITLE THERMAL AND DYNAMIC INVESTIGATION OF THE HUGHES ATS SPACECRAFT AND APOGEE MOTOR SYSTEM AT SIMULATED HIGH ALTITUDE (S/S SYNCHRONOUS SPACECRAFT THERMAL MODEL S/N T-4)			
4. DESCRIPTIVE NOTES (Type of report and inclusive dates) N/A This document has been approved for public release its distribution is unlimited.			
5. AUTHOR(S) (Last name, first name, initial) Domal, A. F., ARO, Inc.			
6. REPORT DATE October 1966		7a. TOTAL NO. OF PAGES 76	7b. NO. OF REFS 5
8a. CONTRACT OR GRANT NO. AF40(600)-1200		9a. ORIGINATOR'S REPORT NUMBER(S) AEDC-TR-66-170	
b. PROJECT NO. 0393			
c. System 920E		9b. OTHER REPORT NO(S) (Any other numbers that may be assigned this report) N/A	
d.			
10. AVAILABILITY/LIMITATION NOTICES Qualified users may obtain copies of this report from DDC, and re- lease to foreign governments or foreign nationals must have prior approval of NASA, Goddard Space Flight Center.			
11. SUPPLEMENTARY NOTES N/A		12. SPONSORING MILITARY ACTIVITY National Aeronautics and Space Ad- ministration, Goddard Space Flight Center, Greenbelt, Maryland	
13. ABSTRACT A NASA/Hughes Aircraft Company, Applications Technology Satellite (ATS) spacecraft, modified for captive testing, was used in an inves- tigation at near vacuum conditions to determine if various spacecraft components would overheat following operation of the apogee "kick" motor. The apogee motor system, a Jet Propulsion Laboratory solid- propellant rocket motor (S/N SR-28-3), was installed in ATS space- craft (S/N T-4) and fired in a "soft stand" (nonspinning) which isolated the motor/spacecraft thermally and dynamically. The motor was ignited and operated at a pressure simulated altitude of 110,000 ft. The thermal data were recorded for 3600 sec after ignition at an average altitude of 125,000 ft. The highest temperature recorded was 935°F and was sensed on the apogee motor nozzle. The highest temperature recorded on the spacecraft was approximately 400°F and was sensed on the thermal barrier at 250 sec after apogee motor igni- tion. The highest spacecraft structural temperature was approximately 240°F, which was sensed 750 sec after apogee motor ignition. The spacecraft electronic component temperatures did not exceed 150°F throughout the entire 3600-sec heat soak period. The vibration data analysis indicated that the motor operation was relatively smooth, and no large power spectral density levels were found.			

14. KEY WORDS	LINK A		LINK B		LINK C	
	ROLE	WT	ROLE	WT	ROLE	WT
satellites (artificial)						
payloads						
solid propellants						
heat-transfer testing						
simulated altitude testing						
performance						

1. apogee motors

2 SPR motors - Heat transfer

2 " " " " Performance

INSTRUCTIONS

1. ORIGINATING ACTIVITY: Enter the name and address of the contractor, subcontractor, grantee, Department of Defense activity or other organization (*corporate author*) issuing the report.

2a. REPORT SECURITY CLASSIFICATION: Enter the overall security classification of the report. Indicate whether "Restricted Data" is included. Marking is to be in accordance with appropriate security regulations.

2b. GROUP: Automatic downgrading is specified in DoD Directive 5200.10 and Armed Forces Industrial Manual. Enter the group number. Also, when applicable, show that optional markings have been used for Group 3 and Group 4 as authorized.

3. REPORT TITLE: Enter the complete report title in all capital letters. Titles in all cases should be unclassified. If a meaningful title cannot be selected without classification, show title classification in all capitals in parenthesis immediately following the title.

4. DESCRIPTIVE NOTES: If appropriate, enter the type of report, e.g., interim, progress, summary, annual, or final. Give the inclusive dates when a specific reporting period is covered.

5. AUTHOR(S): Enter the name(s) of author(s) as shown on or in the report. Enter last name, first name, middle initial. If military, show rank and branch of service. The name of the principal author is an absolute minimum requirement.

6. REPORT DATE: Enter the date of the report as day, month, year; or month, year. If more than one date appears on the report, use date of publication.

7a. TOTAL NUMBER OF PAGES: The total page count should follow normal pagination procedures, i.e., enter the number of pages containing information.

7b. NUMBER OF REFERENCES: Enter the total number of references cited in the report.

8a. CONTRACT OR GRANT NUMBER: If appropriate, enter the applicable number of the contract or grant under which the report was written.

8b, 8c, & 8d. PROJECT NUMBER: Enter the appropriate military department identification, such as project number, subproject number, system numbers, task number, etc.

9a. ORIGINATOR'S REPORT NUMBER(S): Enter the official report number by which the document will be identified and controlled by the originating activity. This number must be unique to this report.

9b. OTHER REPORT NUMBER(S): If the report has been assigned any other report numbers (*either by the originator or by the sponsor*), also enter this number(s).

10. AVAILABILITY/LIMITATION NOTICES: Enter any limitations on further dissemination of the report, other than those

imposed by security classification, using standard statements such as:

- (1) "Qualified requesters may obtain copies of this report from DDC."
- (2) "Foreign announcement and dissemination of this report by DDC is not authorized."
- (3) "U. S. Government agencies may obtain copies of this report directly from DDC. Other qualified DDC users shall request through _____."
- (4) "U. S. military agencies may obtain copies of this report directly from DDC. Other qualified users shall request through _____."
- (5) "All distribution of this report is controlled. Qualified DDC users shall request through _____."

If the report has been furnished to the Office of Technical Services, Department of Commerce, for sale to the public, indicate this fact and enter the price, if known.

11. SUPPLEMENTARY NOTES: Use for additional explanatory notes.

12. SPONSORING MILITARY ACTIVITY: Enter the name of the departmental project office or laboratory sponsoring (*paying for*) the research and development. Include address.

13. ABSTRACT: Enter an abstract giving a brief and factual summary of the document indicative of the report, even though it may also appear elsewhere in the body of the technical report. If additional space is required, a continuation sheet shall be attached.

It is highly desirable that the abstract of classified reports be unclassified. Each paragraph of the abstract shall end with an indication of the military security classification of the information in the paragraph, represented as (TS), (S), (C), or (U).

There is no limitation on the length of the abstract. However, the suggested length is from 150 to 225 words.

14. KEY WORDS: Key words are technically meaningful terms or short phrases that characterize a report and may be used as index entries for cataloging the report. Key words must be selected so that no security classification is required. Identifiers, such as equipment model designation, trade name, military project code name, geographic location, may be used as key words but will be followed by an indication of technical context. The assignment of links, rules, and weights is optional.