

UNCLASSIFIED

AD NUMBER
AD800542
NEW LIMITATION CHANGE
TO Approved for public release, distribution unlimited
FROM Distribution authorized to U.S. Gov't. agencies and their contractors; Administrative/Operational Use; MAY 1966. Other requests shall be referred to Supersonic Transport Program, Federal Aviation Agency, Washington, DC.
AUTHORITY
FAA notice, 2 Jul 1973

THIS PAGE IS UNCLASSIFIED

# SUPERSONIC TRANSPORT PROGRAM PHASE II-C

## BIMONTHLY TECHNICAL PROGRESS REPORT

CONTRACT FA-SS-66-5

D6-18110-5

MAY 1966

AD 800-542



PREPARED FOR  
FEDERAL AVIATION AGENCY  
Supersonic Transport Development Program

PREPARED BY Robert E. Oestrich

APPROVED BY Hans Bethe

THE **BOEING** COMPANY  
SUPERSONIC TRANSPORT DIVISION

ISSUE NO. \_\_\_\_\_

## NOTICES

When Government drawings, specifications, or other data are used for any purpose other than in connection with a definitely related Government procurement operation, the United States Government thereby incurs no responsibility nor any obligation whatsoever; and the fact that the Government may have formulated, furnished, or in any way supplied the said drawings, specifications, or other data, is not to be regarded by implication or otherwise as in any manner licensing the holder or any other person or corporation, or conveying any rights or permission to manufacture, use, or sell any patented invention that may in any way be related thereto.

Copies have been placed in the DDC collection. U.S. Government agencies may obtain copies from DDC. Other qualified DDC users may request, by submission of a DDC Form 1, through:

Director of Supersonic Transport Development  
Federal Aviation Agency  
Washington, D.C. 20553

Defense Documentation Center release to the Clearinghouse for Federal, Scientific, and Technical Information (CFSTI) and foreign announcement and dissemination are not authorized. The distribution of this report is limited because it contains technology identifiable with items excluded from export by the Department of State (U.S. Export Control Act of 1949 as amended).

## CONTENTS

SECTION		Page
I	SUMMARY OF PROGRESS . . . . .	1
II	PROBLEM REPORT . . . . .	3
III	DESCRIPTION OF TECHNICAL PROGRESS . . . . .	5
10	AIRFRAME - GENERAL . . . . .	5
	1001 System Integration . . . . .	5
	1002 Design Analysis . . . . .	19
	1003 Maintainability . . . . .	34
	1004 Reliability . . . . .	37
	1005 Value Engineering . . . . .	40
	1007 Product and System Safety . . . . .	43
	1008 Materials and Processes . . . . .	43
	1009 Mockups . . . . .	71
	1010 Airframe Test, General . . . . .	72
	1012 Flight Test Program . . . . .	72
	1013 Standardization . . . . .	73
	1014 Quality Assurance . . . . .	73
11	AIRFRAME STRUCTURE . . . . .	74
	110C Airframe Structure, General . . . . .	74
	1101 Wing . . . . .	94
	1104 Fuselage . . . . .	100
	1106 Landing Gear . . . . .	101
	1107 Power Plant Structure . . . . .	102
	1108 Empennage . . . . .	102
12	AIRFRAME SYSTEMS . . . . .	102
	1202 Environmental Control System (ECS) . . . . .	102
	1203 Hydraulic Systems . . . . .	103
	1204 Flight Control System . . . . .	104
	1205 Electrical Systems . . . . .	105
	1206 Accessory Drive System (ADS) . . . . .	114
	1207 Automatic Flight Controls . . . . .	114
	1208 Flight Deck Installations and Systems . . . . .	115
	1209 Communications . . . . .	116
	1210 Navigation . . . . .	117
	1211 Electronics - General . . . . .	118
	1212 Fire Detection and Protection . . . . .	119
	1213 Passenger and Cargo Provisions . . . . .	120

CONTENTS (Concluded)

SECTION		Page	
III	13	PROPULSION SYSTEMS. . . . .	122
	1300	Propulsion Systems, General . . . . .	122
	1301	Performance (Installed) . . . . .	123
	1302	Air Induction System . . . . .	124
	1303	Air Induction Control . . . . .	135
	1305	Propulsion Installation . . . . .	153
	1306	Fuel System . . . . .	153
	1307	Exhaust/Reverser System . . . . .	154
	1308	Noise . . . . .	154
	1309	Engine Coordination . . . . .	154
	14	PRODUCT SUPPORT . . . . .	158
	1401	Data and Handbook . . . . .	158
	1402	Spares . . . . .	159
	1403	Training and Training Equipment . . . . .	159
	1404	Ground Support Equipment. . . . .	160
IV		AIRLINE COORDINATION. . . . .	163
V		RELATED BOEING RESEARCH AND DEVELOPMENT . . . . .	165

## ILLUSTRATIONS

Figure		Page
1	General Arrangement, Model B-2707 (GE) . . . . .	7
2	Inboard Profile Model B-2707 (GE) . . . . .	9
3	Balance Diagram and Fuel Tank Arrangement . . . . .	11
4	B-2707 (GE) Payload - Range . . . . .	12
5	B-2707 Engine Sizing Range. . . . .	14
6	B-2707 Engine Sizing Takeoff Performance. . . . .	15
7	B-2707 Engine Sizing Landing Performance. . . . .	16
8	Takeoff Noise Cntours. . . . .	17
9	Takeoff Noise Contours - Power Cut-Back . . . . .	18
10	Aerodynamic Center Locations - Wind Tunnel Data (Rigid Airplane). . . . .	20
11	Flexible Airplane, Static and Maneuver Neutral Points	21
12	Longitudinal Stability, Landing Configuration . . . . .	24
13	Strake Modification to Improve Flaps-Down Stability .	25
14	Transonic Longitudinal Stability Characteristics, ^ LE = 42. . . . .	26
15	Longitudinal Stability Characteristics, ^ LE = 72 . . . . .	27
16	Aerodynamics Wind Tunnel Test Schedule . . . . .	28,29
17	Low-Speed Configuration Development Model WS = 30° . .	31
18	Transonic Configuration Development Model WS = 42 . . .	32
19	Supersonic Configuration Development Model WS = 72 Degrees . . . . .	33
20	Flexural Strength, Skybond 700-High Polar Solvent . . .	52
21	Flexural Strength, Skybond 700-Butanol Solvent+ . . . .	53
22	Flexural Strength, Amoco Al-11. . . . .	54
23	Shear Modulus of HRH-324 Polyimide Honeycomb Co . . . .	57
24	Shear Strength of HRH-324 Polyimide Honeycomb Core. . .	58
25	Polyurethane Foam Heat Aging Characteristics. . . . .	59
26	Effect of Explosive Stress Relief on Residual Stress in Welded Ti 8Al-1Mo-1V . . . . .	61
27	Effect of Explosive Stress Relief on Residual Stress in Welded Ti 6Al-4V . . . . .	62
28	Effect of Residual Stress on Fatigue Life of Riveted Ti 6Al-4V . . . . .	63
29	Heading Force Study for Ti 6Al-4V Rivets. . . . .	64
30	Cycles of Fatigue Loading Hole Size Study for A286 Rivets . . . . .	65
31	Hole Size Study for Ti 6Al-4V Rivets. . . . .	67
32	Cycles of Fatigue Loading Heading Study (Gun Versus Compression) for A286 Rivets . . . . .	68
33	Effect of Temperature on Joining Fatigue Life . . . . .	69
34	Sustained Loading Behavior in Salt Water of 0.250 Inch Mill Annealed Ti 6Al-4V Weld . . . . .	70
35	Tensile and Fracture Toughness Data from Three Heats of Each Alloy . . . . .	76
36	Average Stress Intensity Factors for Three Heats of Each Alloy . . . . .	77
37	Typical Shear Panel and Test Setup. . . . .	79

ILLUSTRATIONS (Continued)

Figure		Page
38	Honeycomb Panel Test Allowables . . . . .	81
39	Final Crack Configuration . . . . .	83
40	Final Crack Configuration . . . . .	84
41	Final Crack Configuration . . . . .	86
42	Final Crack Configuration . . . . .	87
43	Fail Safe Panels. . . . .	88
44	Static Aeroelasticity . . . . .	90
45	Exceedances of Incremental Body Accelerations Elastic Structure (Full Dynamics) SAS Inoperative . .	91
46	RMS Values of Fuselage Acceleration . . . . .	92
47	733-414 Wind Tunnel Installation . . . . .	93
48	733-414 Wing Stiffness Effects on Flutter . . . . .	95
49	733-414 Wing Fuel Effects on Flutter. . . . .	96
50	Supersonic Flutter Test . . . . .	97
51	Supersonic Wing Flutter Test 733-390 Wing Configuration . . . . .	98
52	733-362 Fin Test Envelope BSWT - SA894D-2 . . . . .	99
53	Power Distribution and Busses . . . . .	107
54	Fuel Pump Power Source Schematic. . . . .	109
55	Electrical Panel Diagram. . . . .	110
56	Electrical Panel Diagram. . . . .	111
57	Inlet Performance, One-Fifth-Scale Inlet. . . . .	125
58	One-Fifth Scale Inlet, Distortion Data. . . . .	126
59	Mockup of One-Third-Scale SST Inlet-Engine. . . . .	128
60	Inlet Flow Field Rakes Installed on B-2707 Configuration . . . . .	129
61	Variation of Inlet Flow Angles with Airplane Angle of Attack . . . . .	130
62	Variation of Inlet Local Mach Number with Airplane Angle of Attack . . . . .	131
63	Propulsion Testing Schedule . . . . .	132
64	Full-Scale Test Centerbody, Expanded Position . . . .	133
65	Full-Scale Test Centerbody, Contracted Position . . .	134
66	Full-Scale Inlet Mockup . . . . .	136
67	Full-Scale Inlet Mockup . . . . .	137
68	Augmentor Blowout, GE Engine and Inlet. . . . .	138
69	Control Sensor Bench Test Block Diagram . . . . .	139
70	Centerbody Loop Test with Hamilton Standard Sensor, $M_L = 1.8$ . . . . .	141
71	Centerbody Loop Test with Hamilton Standard Sensor, $M_L = 2.55$ . . . . .	142
72	Centerbody Loop Test with Hamilton Standard Sensor, $M_L = 2.55$ , Optimized. . . . .	143
73	Pneumatic Line Response Characteristics, Center- body Loop . . . . .	144
74	Hamilton Standard Centerbody Sensor Response Characteristic . . . . .	145
75	Centerbody Actuator Response Characteristics. . . . .	146

ILLUSTRATIONS (Concluded)

Figure		Page
76	Electronic Centerbody Controller Hysteresis Test . . .	147
77	Electric Centerbody Controller Hysteresis Error. . .	148
78	Boeing Electronic Centerbody Sensor. . . . .	149
79	Centerbody Controller Dynamic Test . . . . .	150
80	Bypass Control Signal Characteristics. . . . .	152
81	Symmetrical Reverser with Steam. . . . .	155
82	Unsymmetrical Reverser with Steam. . . . .	156
83	Noise Suppressor Models. . . . .	157
84	Wind Tunnel Model Planform . . . . .	172
85	Leading Edge Flap Geometry . . . . .	173
86	Effect of Blowing BLC at Strake Leading-Edge on Lift . . . . .	175
87	Effect of Blowing BLC at Strake Leading-Edge on Drag . . . . .	176
88	Effect of Blowing BLC at Strake Leading-Edge on Pitching Moment. . . . .	177

TABLES

Table		Page
A	B-2707 (GE) Performance Summary . . . . .	13
B	High Temperature Grease Evaluation. . . . .	47
C	Average Wear Lives of Commercially Available Solid Film Lubricants at 450°F and 10,000 PSI Load Conditions. . . . .	49
D	Wear Life of Anti-Galling Lubricant Coatings for Titanium. . . . .	51
E	Stability Exposure Data . . . . .	74
F	Properties of 9Ni-4Co-0.45C Bainitic-Treated Steel. . .	78
G	Shear Strengths in Diffusion Welded and Brazed Ti-6Al-4V . . . . .	166

## I. SUMMARY OF PROGRESS

### A. CONFIGURATION DEVELOPMENT

Although the 733-414 configuration established in March eliminated virtually all of the basic deficiencies of the 733-390 configuration, additional improvements were considered desirable. Therefore, evolutionary changes to the Mach configuration were investigated. As a result, a new proposal baseline configuration was established in mid-May, identified as the Model B-2707. The distinguishing characteristics of this configuration are:

- (1) Enlarged horizontal tail, with tail-mounted engines.
- (2) Horizontal tail and movable wing arranged with only a small gap between with wing in swept back position. They function as a single airfoil during supersonic cruise.
- (3) Increased span flaps that also serve as landing gear debris deflectors on landing and takeoff.
- (4) Four-post landing gear arrangement that utilizes both the fixed wing and the body for stowage ~~on~~ retraction.
- (5) Increased passenger space and gross weight.

This new configuration achieves several notable improvements over the 733-414 configuration. Some of the more important ones include:

- (1) Lowered wave drag, resulting in improved supersonic cruise aerodynamic efficiency.
- (2) Elimination of airframe problems associated with engine exhaust.
- (3) Improved stability and control characteristics in all flight regimes.
- (4) Improved subsonic performance.
- (5) Improved flap efficiency.
- (6) Improved structural efficiency.
- (7) Improved economic characteristics.

The model B-2707 (GE) will carry 50,000 pounds of payload over a 4000 statute mile range, with a climb sonic boom overpressure value of 2.5 psf.

## I. Summary of Progress (continued)

### B. DESIGN SUPPORT

The strengthening of the design support organization has continued. The following new supervisory appointments were recently made:

J. E. Huffington - Safety Staff Manager, L. J. Onewein - Maintainability Staff Manager, and A. L. Paxhia - Standardization Staff Manager.

Increased manpower staffing of the design support groups since March is as follows: Safety - From 5 to 9, Maintainability - From 6 to 20, Standardization - From 2 to 4, Reliability - From 6 to 29, Data Central - From 12 to 17, and Maintenance Engineering - From 7 to 10.

### C. HONEYCOMB PANEL DEVELOPMENT

There has been a progression of improvements in polyimide honeycomb core materials during the past few months. One of the improved materials is HRH-324, a standard-weave reinforced polyimide material reported earlier. More recently, Hexcel Products Inc. has developed a new bias-weave reinforced polyimide honeycomb core material, HRH-327, that has demonstrated properties far superior to all other core materials investigated to date. At low exposure durations, HRH-327 has demonstrated nominally 25 percent greater shear strength and 300 percent greater shear rigidity than the HRH-324 material. These improvements are expected to result in higher panel allowables.

Lightning strike tests have been carried out at the Joslyn Electronic Systems laboratories to investigate puncture resistance of several types of honeycomb panels. Where plain titanium panels were punctured easily, a polyimide core titanium honeycomb panel was not punctured by the 400-coulomb charges.

### D. WING PIVOT BEARING DEVELOPMENT

Testing of bearings 11 and 12, the three-piece bearings of the "-5 modified" configuration referred to in the March Bimonthly Technical Progress Report, is in progress in the 1/4-scale test program. As of now, 255,000 cycles have been successfully completed.

Testing on the full-scale test rig is continuing. As of now, 27,500 airplane flight load cycles have been successfully completed. Assuming 1-1/2 hours per SST airplane flight, this is equivalent to 40,000 flight hours. The SST service life objective is 50,000 flight hours.

### E. ENGINE INLET DEVELOPMENT

One-tenth scale wind tunnel model tests are being conducted to verify satisfactory low-speed inlet operation for the B-2707

D6-18110-5

### E. Engine Inlet Development (continued)

configuration. The first runs were satisfactory; expected inlet recovery and distortion values were obtained.

Assembly of the full-scale structural test centerbody has been completed. Several actuation cycles were demonstrated for General Maxwell during his visit on May 16, 1966. The centerbody will be installed in the test tank in early June.

The full-scale mockup of the complete inlet assembly was completed in late May. The outer cowl incorporates operating bypass doors and centerbody bleed air exit louvers.

A digital simulation of the inlet and the GE and P&W engines has been made to investigate transient operation of the propulsion system when subjected to various disturbances. Preliminary analysis indicates that the inlet control system maintains satisfactory operation during upstream disturbances.

Dynamic bench testing of a complete inlet centerbody control loop employing the Hamilton-Standard hydromechanical sensor has been completed. Tests with conditions corresponding to 1.8 and 2.55 inlet local Mach numbers were conducted. The results of the bench testing were encouraging. Although the overall loop time constant at the higher Mach number was unacceptable, acceptable results are expected in future testing when more accurate values of the aerodynamic loop gain function are available. The latter data will be derived from 1/5-scale inlet tests.

Bench testing of a Boeing-developed electronic inlet centerbody control sensor has also been completed. Early results show this unit has faster response and is more accurate than the Hamilton-Standard unit.

## II. PROBLEM REPORT

### HONEYCOMB PANEL CHARACTERISTICS NOT YET SUBSTANTIATED FOR LONG LIFE AT HIGH-TEMPERATURE AND HIGH-SONIC-FATIGUE ENVIRONMENT (1101-1)

The design requirements associated with sonic resistance to fatigue have been greatly reduced on the latest configuration as a result of relocation of the engines to the aft end of the airplane. Although the exposed area subjected to high sound levels is greatly reduced on the Model B-2707, the current test program on sonic testing of polyimide honeycomb sandwich panels will be continued. This test program proceeds slowly because of the large amount of panel exposure test time involved. Therefore, further results will not be obtained and reported until the July, 1966, Bimonthly Technical Progress Report.

D6-18110-5

### III. DESCRIPTION OF TECHNICAL PROGRESS

#### 10. AIRFRAME - GENERAL

##### 1001. System Integration

##### 10011. CONFIGURATION DEVELOPMENT

The March 1966 Bimonthly Technical Progress Report gave details of a model 733-414 study configuration which eliminated all of the basic deficiencies of the 733-390 configuration. Also, that report stated that other configurations were under investigation. All of this activity culminated in the selection of the Phase III baseline configuration in mid-May, which has been designated the Model B-2707. A general arrangement drawing of this configuration is shown in Fig. 1.

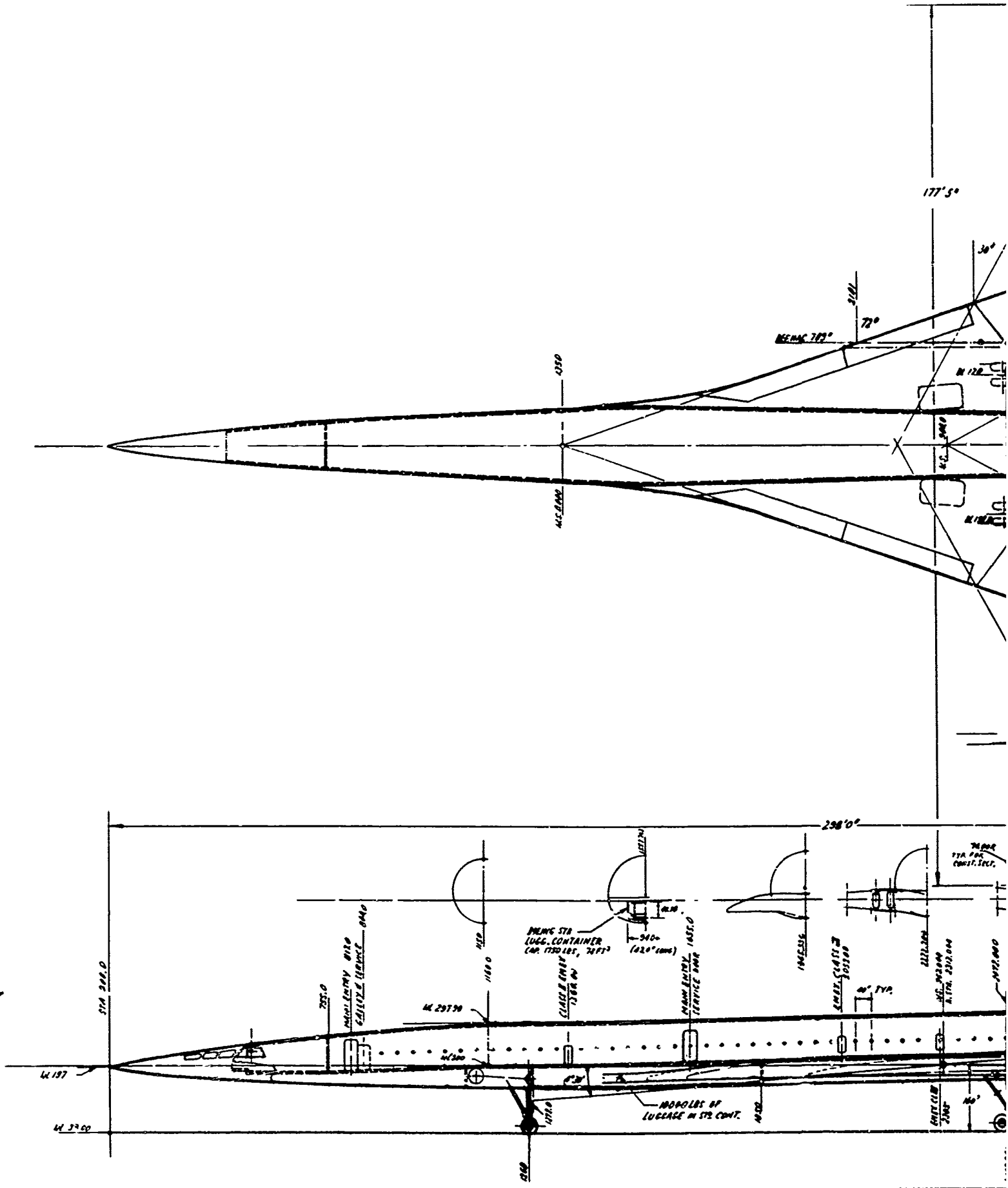
Although the 733-414 configuration basically eliminated the deficiencies of the 733-390 configuration, it was apparent that further improvements would be desirable. For example, the "close-coupled" tail arrangement of the 733-414 resulted in a more outboard location of the wing pivots and less wings-forward span. Low-speed stability and control characteristics were unacceptable, and low-speed range capabilities were reduced.

The enlarged horizontal tail of the B-2707 permitted movement of the engines to that location, thereby eliminating all of the engine exhaust problems associated with previous configurations. The enlarged horizontal tail and the swept-back wings are so positioned as to allow them to function as a single airfoil. The most significant result is reduced wave drag. Also, this arrangement permitted increases in spar depth for both the wing and the horizontal tail, thereby improving structural efficiency and permitting an improved flap arrangement. The relocation of the engines permits greater flap span. The flaps will protect the engine inlets from foreign object ingestion during takeoff and landing.

There is a small gap between the wing and tail in the supersonic cruise configuration. Testing has shown that the drag associated with the slot and mismatch due to normal flight deflection is small. Testing is continuing in the wind tunnel to tailor the slot and tail leading edge to obtain as much benefit as possible from this arrangement.

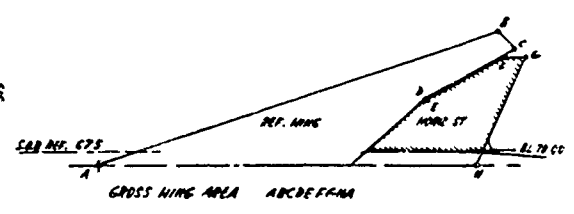
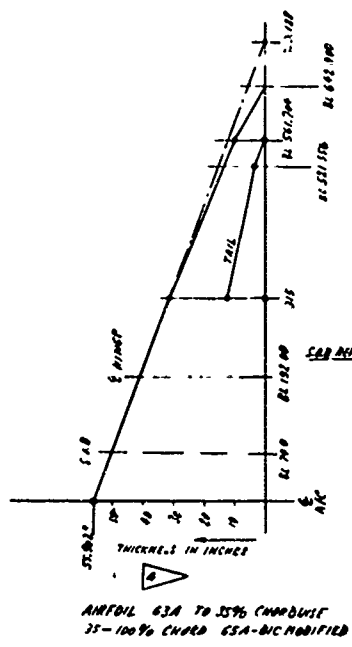
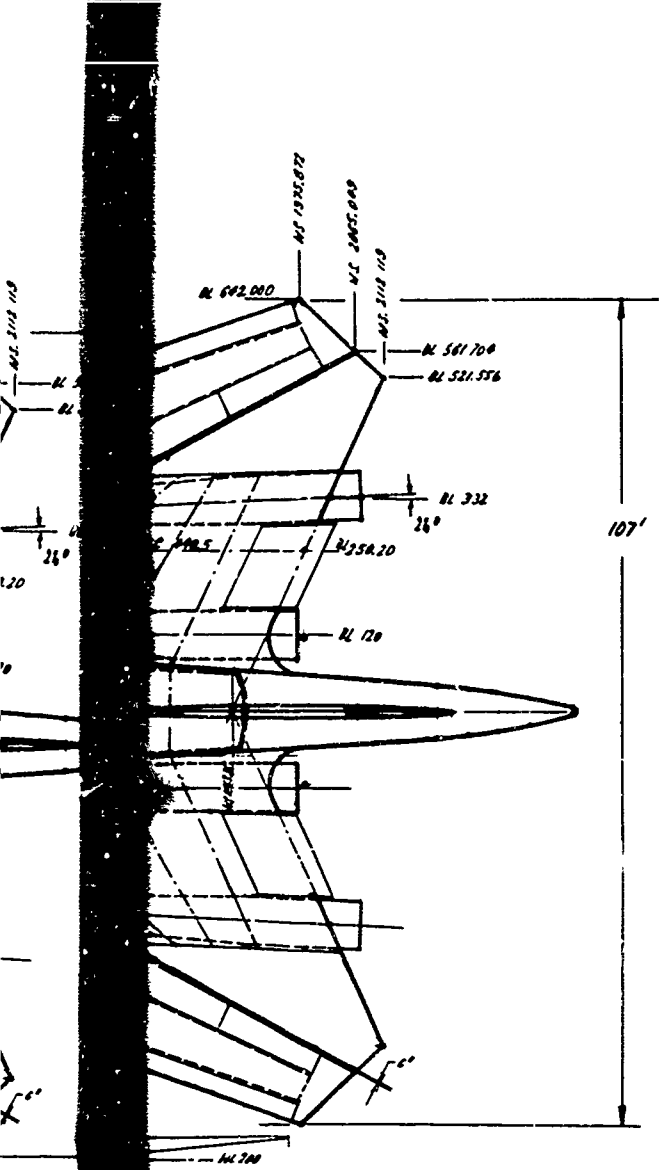
The gross weight and payload were increased to improve the payload-weight fraction. The increase in payload to 277 passengers permitted the utilization of a six-abreast body, 298 feet long. Lower forward cargo bays are designed to accept 10,000 pounds of palletized cargo, using 727 type pallets.

Directional control is provided from the single rudder, actuated from within the body. Wings-forward lateral control is by outboard ailerons and spoilers on the movable wing. The wings aft lateral control is by the elevons on the horizontal tail. Longitudinal control is by the elevons for all flight conditions.



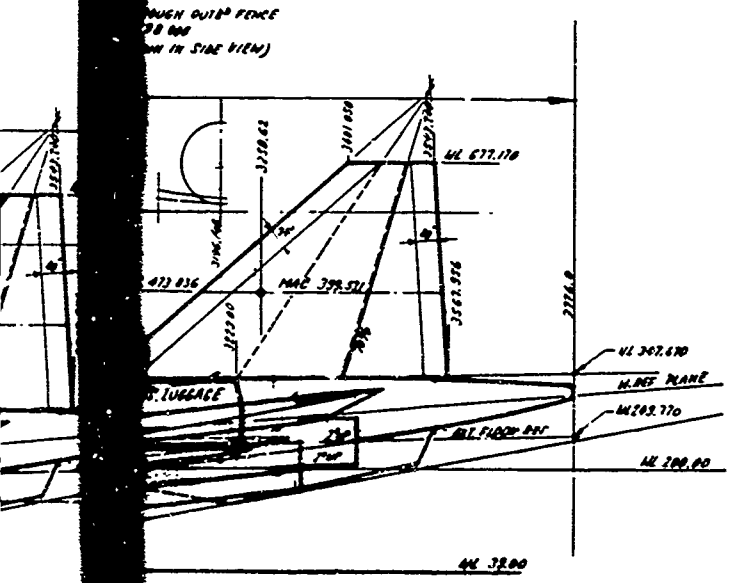
A





- 1 ALLOWABLE PAYLOAD 75000 LBS
- SPACE LIMITED PAYLOAD 67075 LBS
- INTERM ECON PAYLOAD (90-10) 55000 LBS
- MISSION PAYLOAD (4000 MI) 50000 LBS
- MAX. RANGE PAYLOAD 15000 LBS
- 2 FWD GEAR 50% MAC
- AFT GEAR 66% MAC

TITANKUM M.2.7			
GROSS WEIGHT	PAYLOAD	90-10 PAYLOAD	
600000	75000	275 MISS	
SURFACES			
AREA	REF. AREA	MONO. ST. AREA	VERTICAL
3850	8900	3400	800
LE SLOPE	72°	57°42'	58°
TAPER RATIO	—	.2	.25
ASPECT RATIO	1.96	2.89	.95
THICKN. RATIO	—	—	3%
VOLUME COEFF	—	.312	.078
DIBEDRAL	0°	0°	—
PIVOT LOCATION			
29.3% SPAN WISE			
42.3% CHORDWISE			
BODY			
WING	277	6'10"	230'
HEIGHT	15000	15000	15000
POWER PLANT			
NUMBER	4	TYPE	AT-100
LANDING GEAR	3	TYPE	AT-100
HEIGHTS			
WING	38000	311500	
C.G. LIMITS			

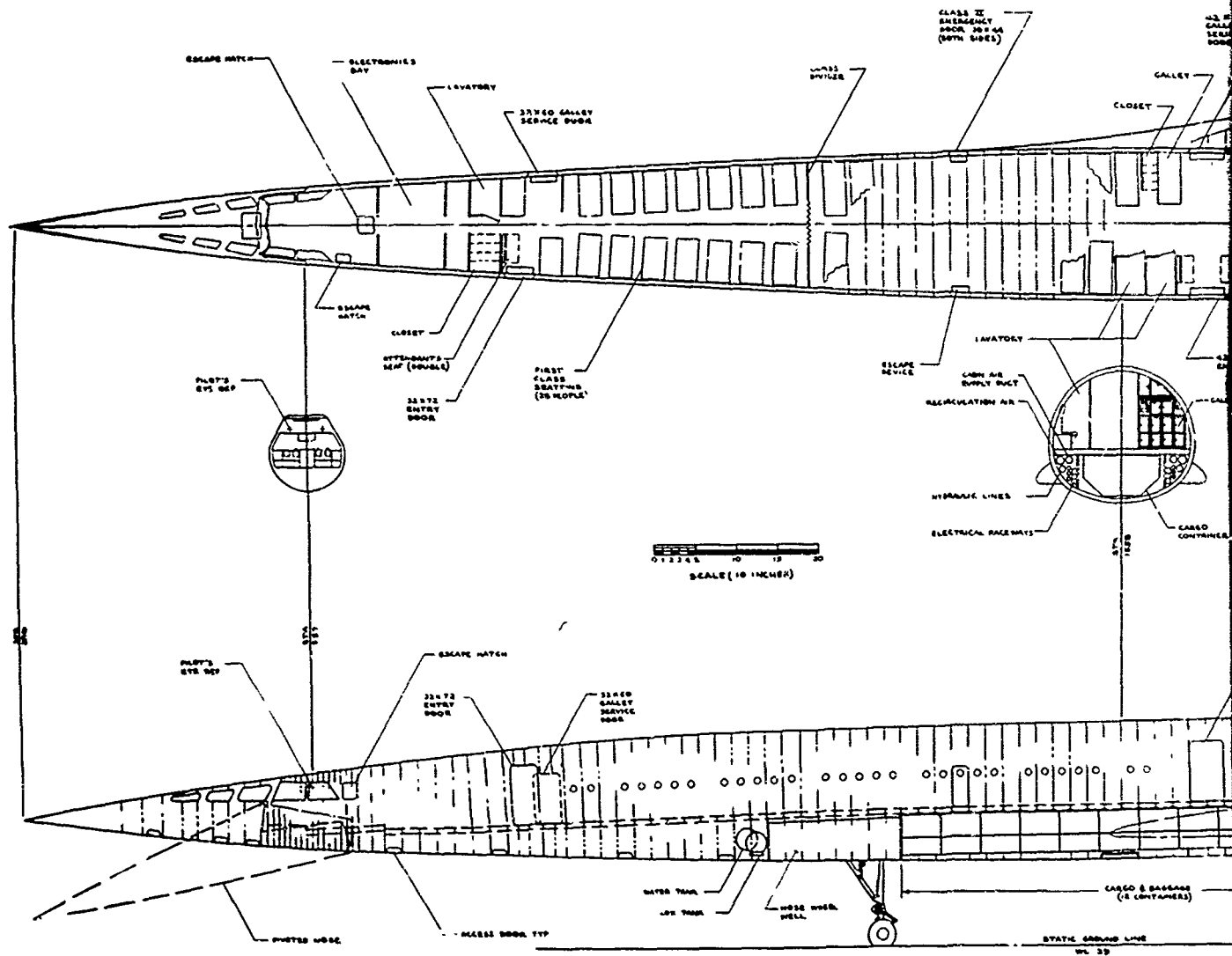


3 C.G. LOCATION:  
 PAY AFT OME 25% MAC (72)  
 PAY G.M.T. WINGS AFT 87% 257000 @ 25% MAC (54-58)  
 PAY 247000 @ 25% MAC (42-48)  
 LANDING G.M.T. CG 247000 @ 25% MAC (42-48)

DESIGN	DATE	THE BOEING COMPANY AIRPLANE DIVISION BENTON WASHINGTON
CHECKED		
STRUCT		GENERAL ARRANGEMENT MODEL B2707 (GE)
REVISION		
DATE	1-12-46	CODE 10811 NO 81205
SCALE	1/100	
		65A10191

THE Boeing Company assumes no liability for the use of this drawing in connection with any project without the specific approval of the Chief Engineer.

Figure 1. General Arrangement, Model B-2707 (GE)



A

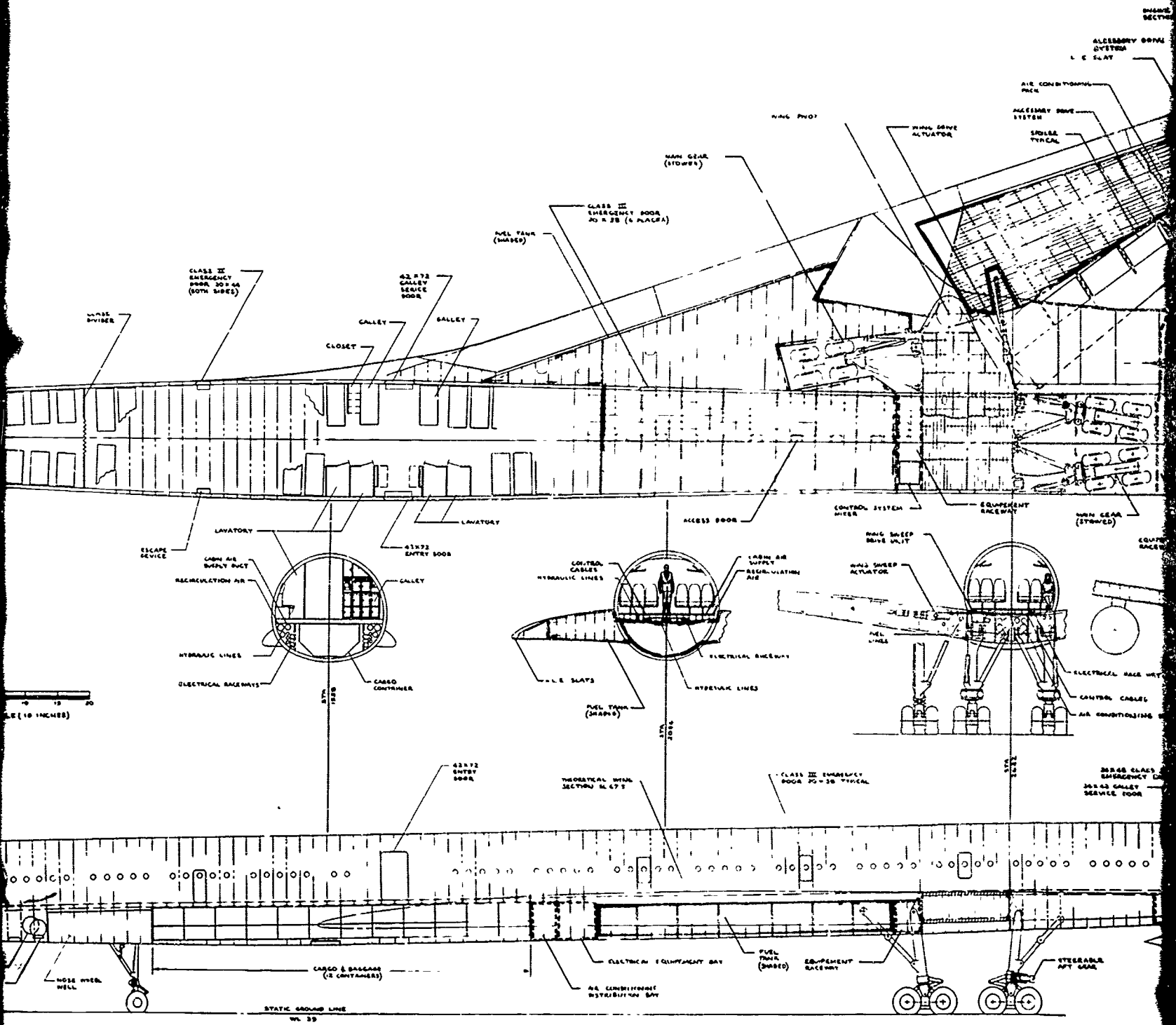


Figure 2. 1

B

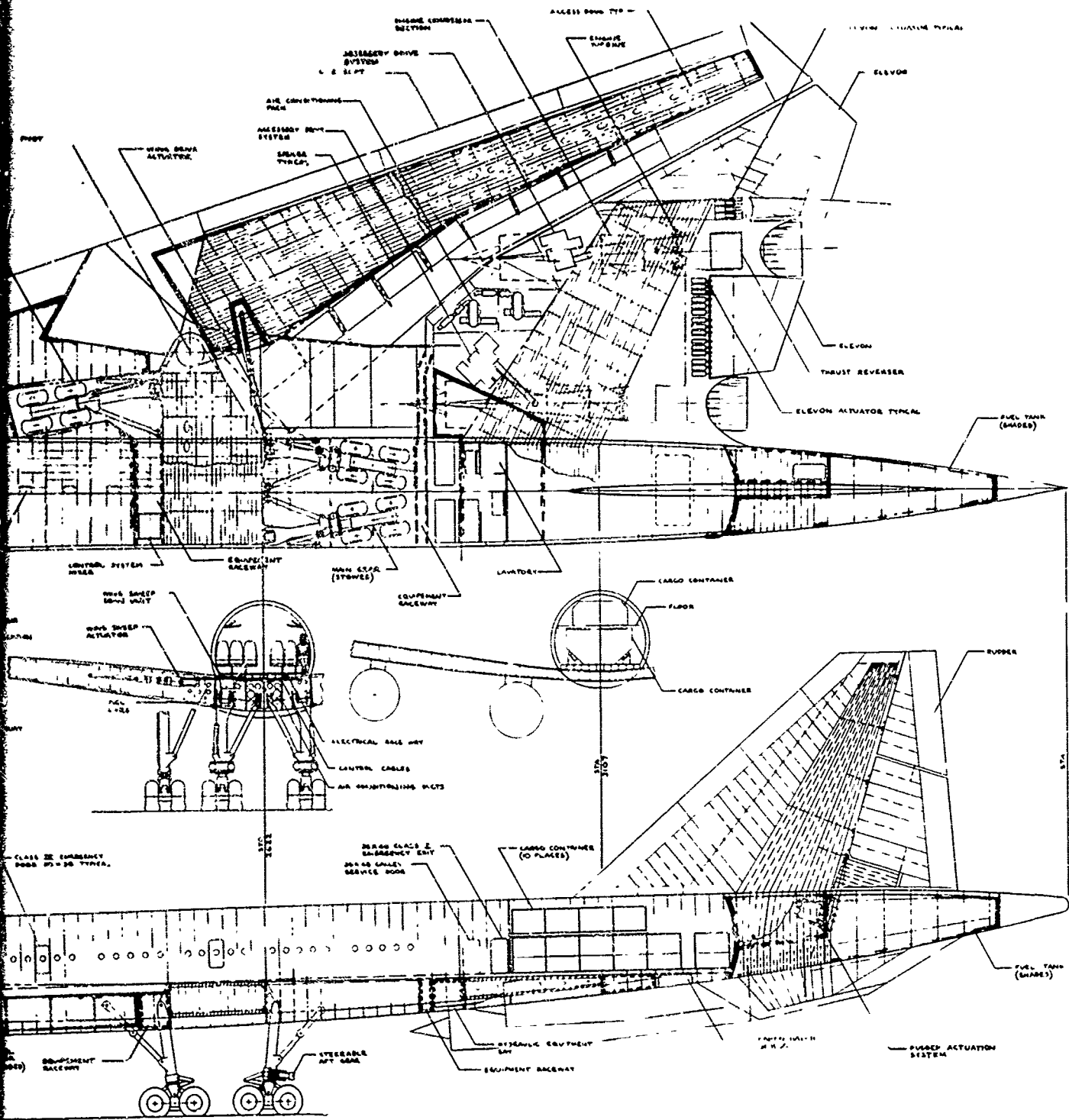


Figure 2. Inboard Profile Model B-2707 (GE)

### III. Description of Technical Progress (continued)

#### 10013. Weight and Balance Control Analysis (continued)

The results of the preliminary balance analysis are shown in Fig. 3. Airplane c.g. control is accomplished by simple fuel management which utilizes low fuel transfer rate from main tanks 1 and 4 to main tanks 2 and 3 during the initial cruise. For normal payloads, the reserve fuel for engines 1 and 4 is located in main tanks 1 and 4. For low payloads some or all of this reserve fuel is located in reserve tanks 1 and 4.

The prototype weight control program has been initiated as noted in the detail work plan. The outline will be submitted as Boeing document D6A10170-1, SST Prototype Weight and Balance Control Plan.

#### 10014. PERFORMANCE ANALYSIS

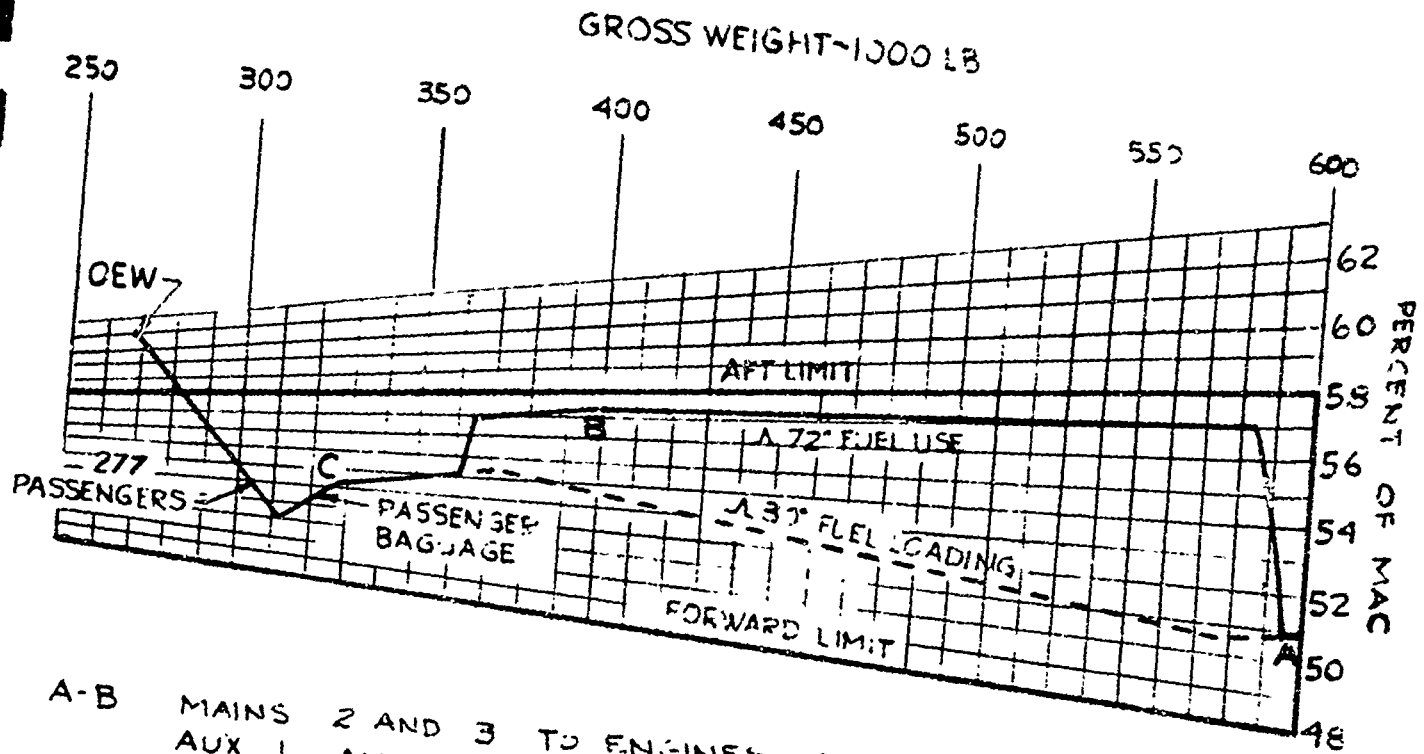
The payload-range of the Boeing Model B-2707 (GE) is shown in Fig. 4. It shows that a payload of 67,000 pounds (the space limit) can be transported over a range of 3500 statute miles. A climb overpressure of 2.85 psf was used in the mission calculations which is only slightly higher than the objective.

Table A summarizes the performance characteristics of the Boeing Model B-2707 (GE). A payload of 50,000 pounds can be transported 4000 statute miles with a climb sonic boom overpressure of 2.5 psf, meeting the established objectives.

The basic performance data presented for the B-2707 (GE) utilizes the GE4/J5P2 study engine at 600 pounds per second airflow. Figures 5 through 7 show the other engines offered and study engines versus airflow. Circles on the plots denote engine sizes. See Par. 1301 for more information on relative thrust, SFC, and powerplant weight of the various engines.

Range data are presented in Fig. 5 for all of the offered and study engines. The Pratt and Whitney engines could be utilized to power the B-2707 but a slight increase in gross weight would be required to meet the same payload-range objectives as the GE4/J5P2 powered version. Takeoff and landing data are presented in Figs. 6 and 7.

Lateral noise contours for the B-2707 (GE) are shown in Fig. 8 where maximum dry power has been used throughout the climb to the 3 mile point. Figure 9 shows the noise reduction which is possible by a change in power setting at the 100 foot altitude point. The rate of climb is about 1200 feet per minute until the 3 mile point is reached. It is noted that, at 10,000 feet from brake release, the 110 PNdb noise contour is reduced about 2500 feet, a very significant reduction.



- A-B MAINS 2 AND 3 TO ENGINES 2 AND 3  
AUX 1 AND 4 TO ENGINES 1 AND 4  
TRANSFER FROM MAINS 1 AND 4 TO MAINS 2 AND 3
- B-C MAINS 1, 2, 3 AND 4 TO ENGINES 1, 2, 3 AND 4

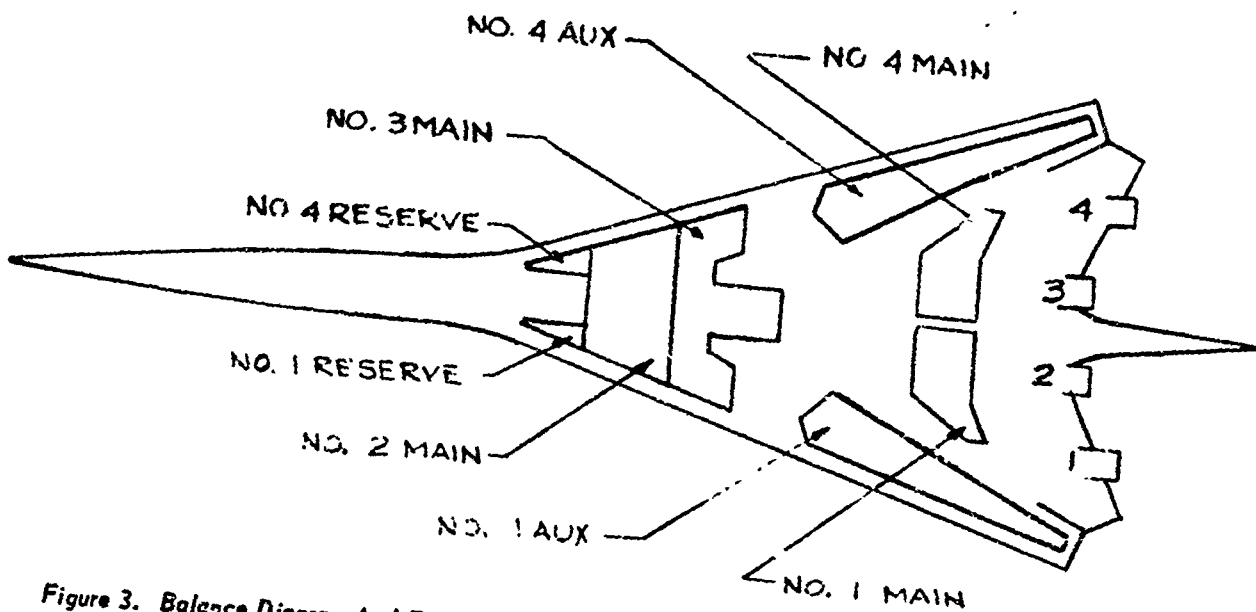


Figure 3. Balance Diagram And Fuel Tank Arrangement

D6-18110-5

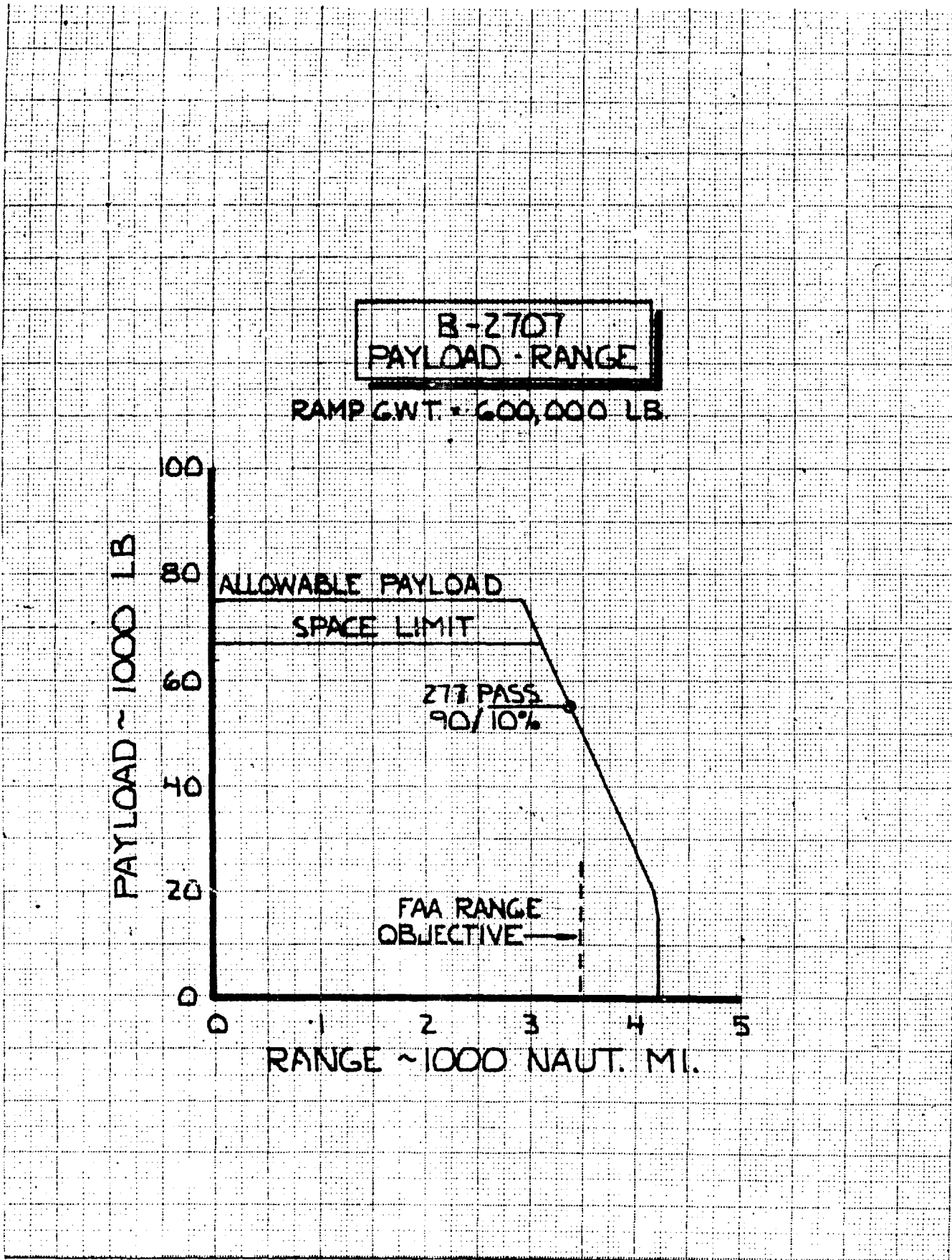


Figure 4. B-2707 (GE) Payload - Range

Table A. B-2707 (GE) Performance Summary

		F.A.A. Objective	
Ramp Gross Weight lb.		600,000	
Payload ~ lb.		47,900	
Range ~ Statute Miles		4,000	4,000
O.E.W. ~ lb.		268,500	
Space-Limited Payload ~ lb.		67,065	
Thrust Margin	1.0 < M < 2.0	.514	
( $\frac{T-D}{D}$ ) Std. Day	2.0 < M < 2.7	.49	
Sonic Boom Overpressure ~ PaF	Climb Max.	2.5	2.5
	Initial Cruise	1.8	1.7
	Descent Max.	1.6	1.5
Reserves ~ Lb.	5% Block Fuel	11,940	
	Missed Approach	2,090	
	Alternate Field	19,150	
	Hold at 15,000 Ft.	9,130	
	Total	42,310	
Takeoff: Sea Level Std. Day  Std + 15°C. →	F.A.R. Field Length ~ ft.	7,250	
	Flap Setting ~ deg.	30	
	Power Setting	Max. Dry	
	Airport Noise ~ PNdb	117	116
	Comm. Noise ~ PNdb	103	105
	Lift-Off Speed ~ kt.	158	
	F.A.R. Field Length ~ ft.	8,900	10,500
Normal Landing Weight ~ lb.		359,000	
Approach: Θ <sub>Body</sub> = 6.8°	Speed ~ kt.	133.5	
	Noise ~ PNdb	109	109
	Flap Setting ~ deg.	30	
Landing: Sea Level	F.A.R. Field Length ~ ft.		
	- Dry Runway ~ ft.	6,380	
	- Wet Runway ~ ft.	4,650	8,000

# B-2707 ENGINE SIZING RANGE

R.G.Wt. = 600,000 LB

P.L. = 50,000 LB

S.W. = 5900 FT<sup>2</sup>

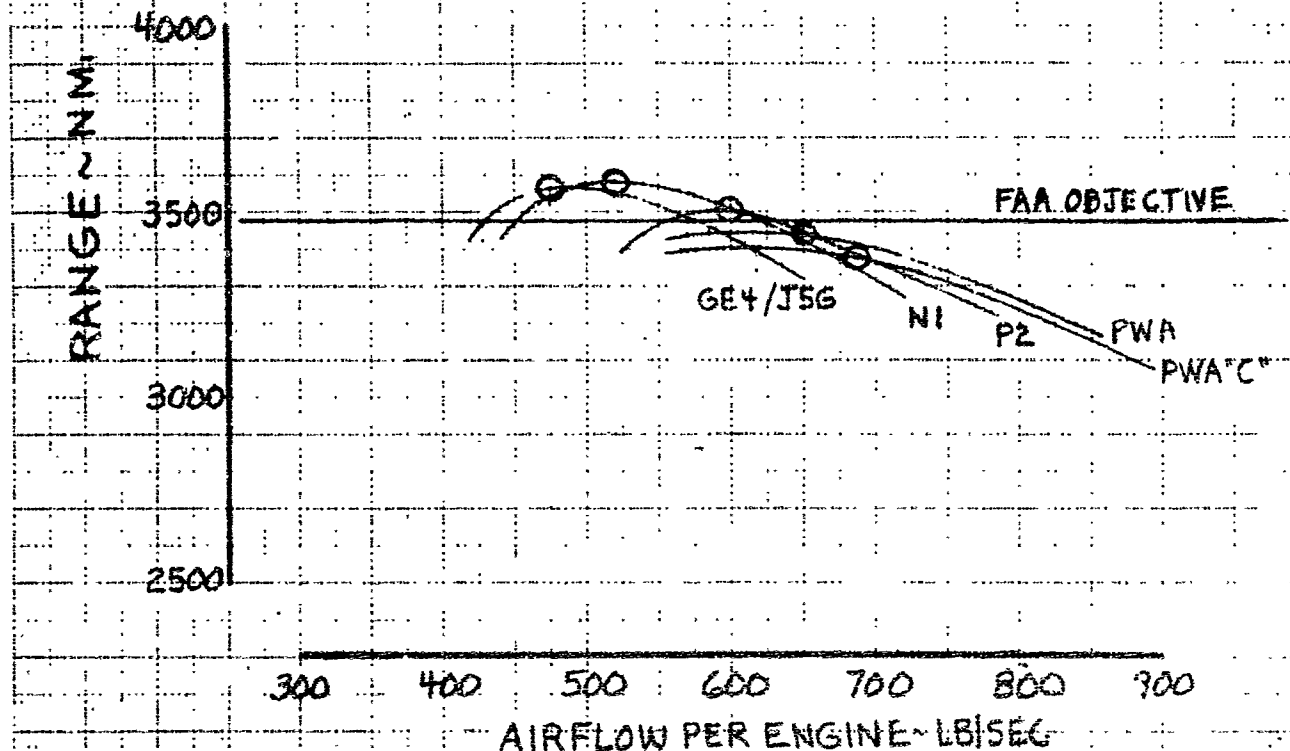


Figure 5. B-2707 Engine Sizing Range

D6-18110-5

# B-2707 ENGINE SIZING

## TAKEOFF PERF

Sw = 8900 FT<sup>2</sup>

R<sub>G</sub> NT = 600000 LB

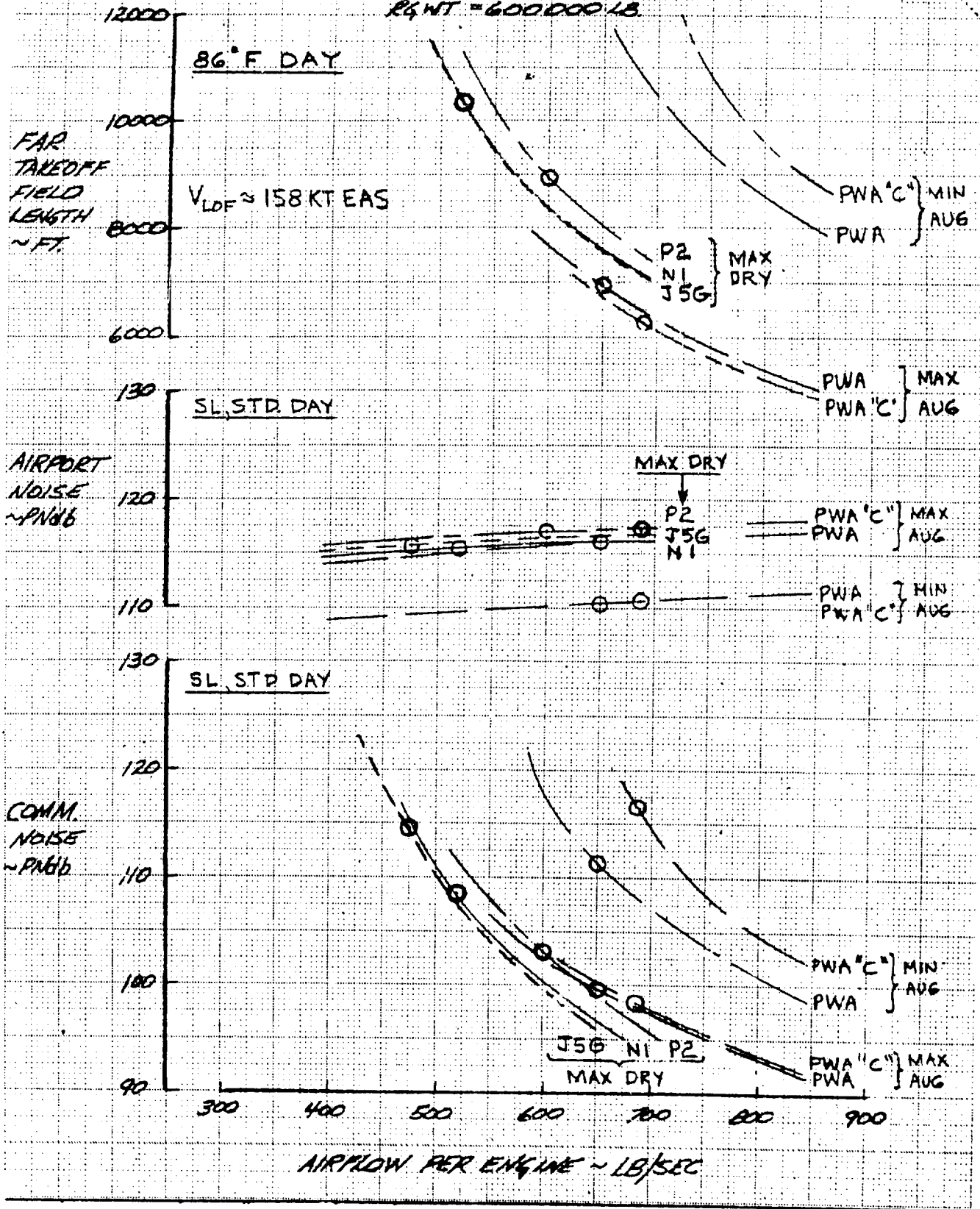


Figure 6 B-2707 Engine Sizing Takeoff Performance

# B-2707 ENGINE SIZING LANDING PERF.

RW<sub>T</sub> = 600,000 LB.  
 PL = 50,000 LB  
 S<sub>w</sub> = 8900 FT<sup>2</sup>  
 30° FLAPS

NORMAL LANDING WT.

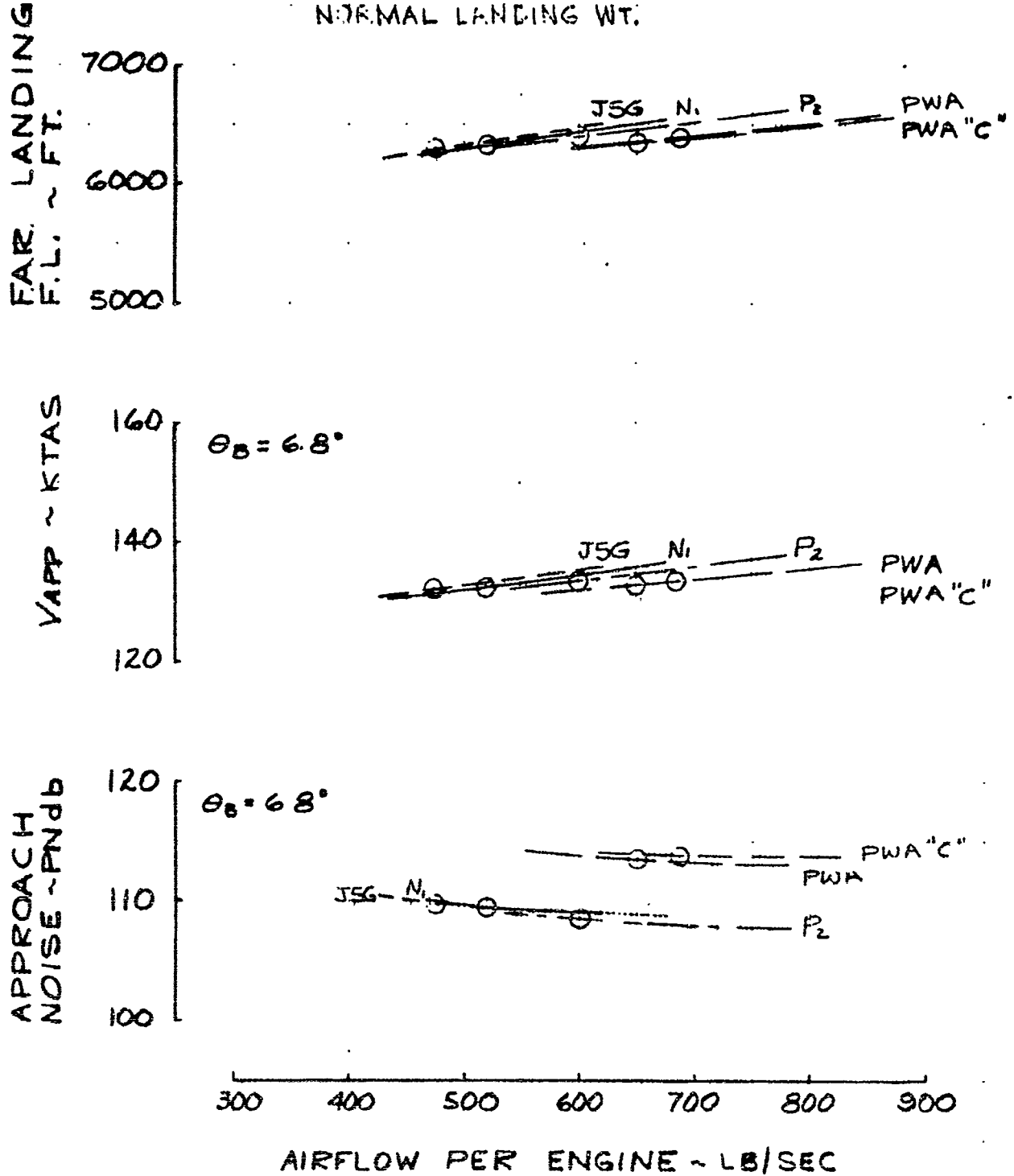
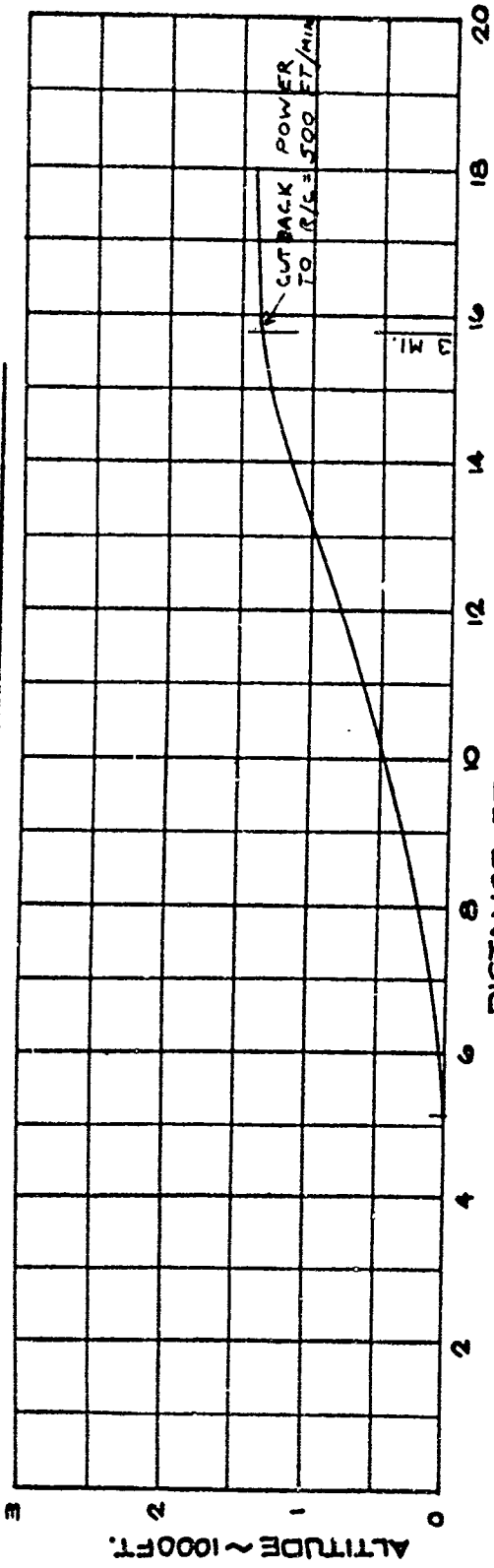


Figure 7. B-2707 Engine Sizing Landing Performance

D6-18110-5

# MAX. DRY POWER TAKEOFF



B-2707  
 R.G.W. = 600,000 LB  
 STD. DAY

DISTANCE FROM BRAKE RELEASE ~ 1000 FT.  
 GE4/JSP2 ENGINES  
 NO PUMP LIMIT  
 W<sub>0</sub> = 600 LB/SEC.

FLAPS 30° FOR TAKEOFF  
 RETRACT TO 20° AT 400 FT.

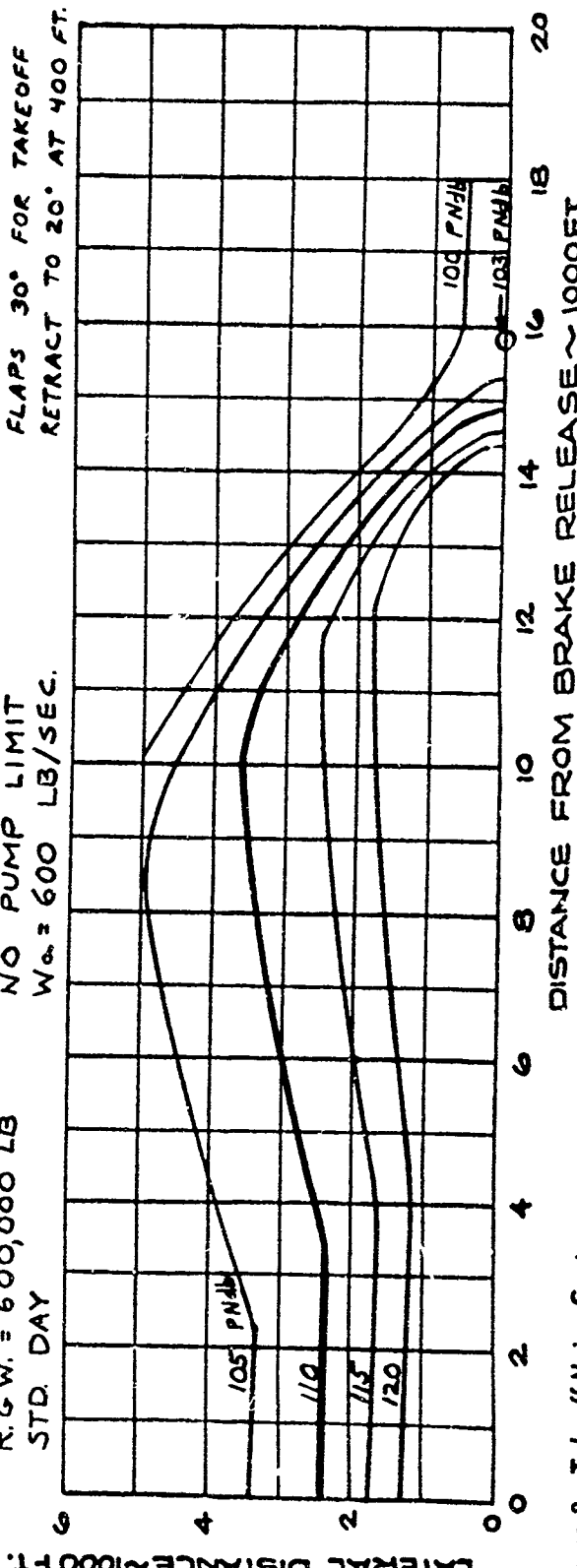


Figure 8. Takeoff Noise Contours

LOW LATERAL NOISE TAKEOFF PROCEDURE

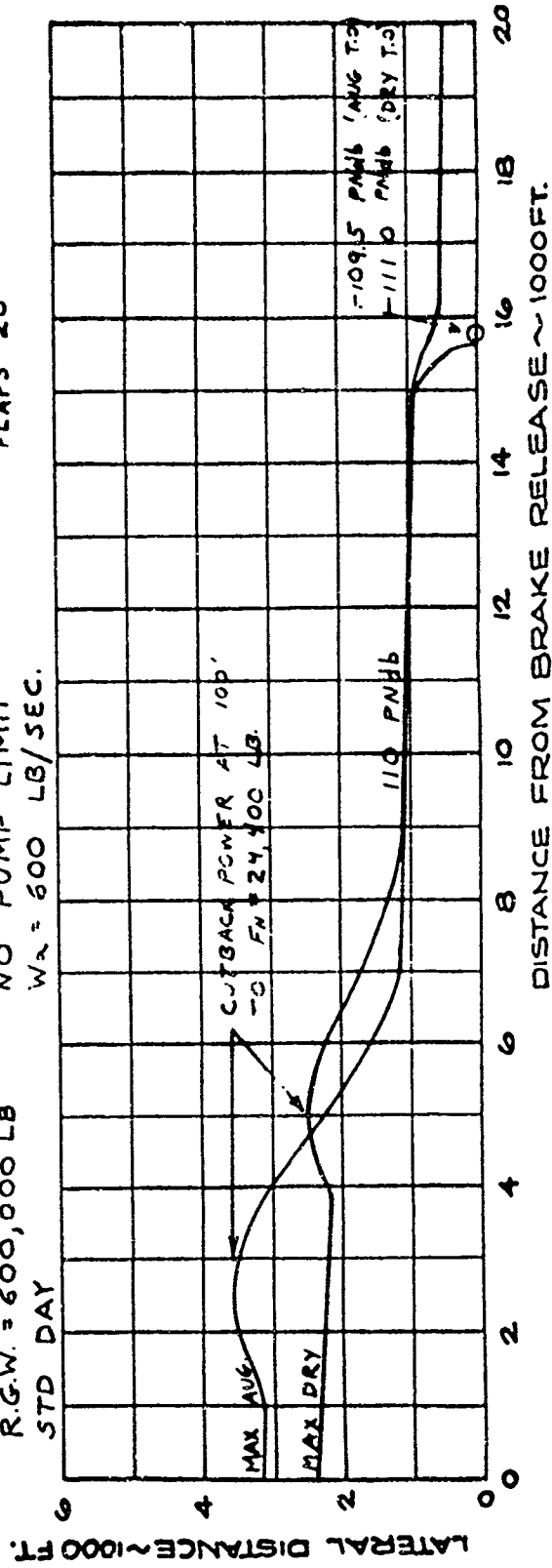
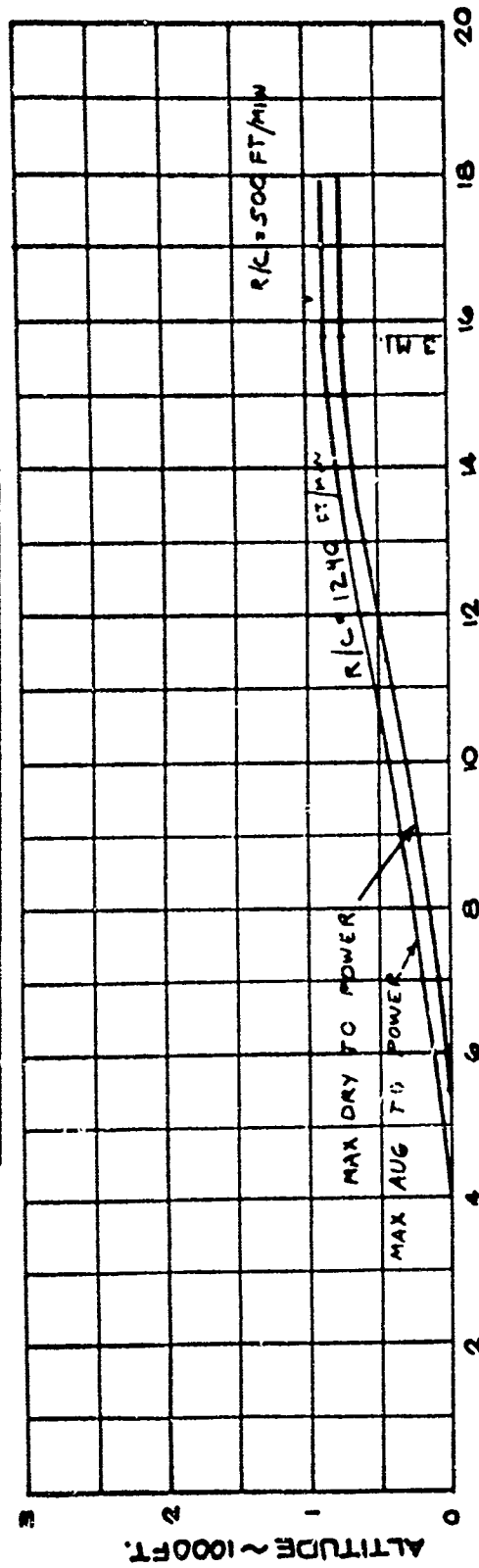


Figure 9. Takeoff Noise Contours - Power Cut-Back

### III. Description of Technical Progress (continued)

#### 1002. Design Analysis

##### Flight Simulation

During May progress has been made toward making the full mission profile simulation operational. Work is also continuing on this simulation to update the aerodynamic, mass, and geometric data to be consistent with the B-2707 configuration. The effects of inlet unstarts are also being included for flight simulator evaluation.

##### Flight Dynamics Analysis

During April and May an analog computer study was made of the takeoff rotation maneuver to determine pitch control power requirements for an integrated wing-tail configuration. The computer was reprogrammed during May to include the effects of extensible landing gear oleos and evaluate a configuration with a four-post, gear arrangement. Work in this area is continuing in an effort to establish control power requirements for the various landing-gear arrangements under consideration.

#### 10023. STABILITY AND CONTROL

The large horizontal tail of the B-2707 configuration provides longitudinal stability characteristics which are greatly improved over those of past small-tail configurations.

Large trimmable elevons replace the all-movable horizontal tail of the 733-414 longitudinal control system. The B-2707 lateral control system consists of conventional ailerons and spoilers mounted on the wing for low-speed roll control, wings forward. At maximum wing sweep the aileron-spoiler system is phased out, and the tail-elevons provide the wings-back, high-speed roll control. The conventional slab rudder control system of the 733-414 has been retained.

A summary of the rigid airplane aerodynamic center variation with Mach number is presented in Fig. 10. The aerodynamic centers shown were obtained from wind tunnel test data of models closely approximating the B-2707 airplane. The large horizontal tail has resulted in a further aft longitudinal balance. This is shown in Fig. 11 by the center-of-gravity relation to the critical (most forward a.c.) stability neutral points for the flexible airplane. The aft center-of-gravity limit has initially been set at 58 percent of the mean aerodynamic chord of the

**AERODYNAMIC CENTERS  
OBTAINED FROM  
WIND TUNNEL TEST DATA**

DATA OBTAINED FROM: UWAL 857  
BTWT 965 & 967  
BSWT 349 & 353

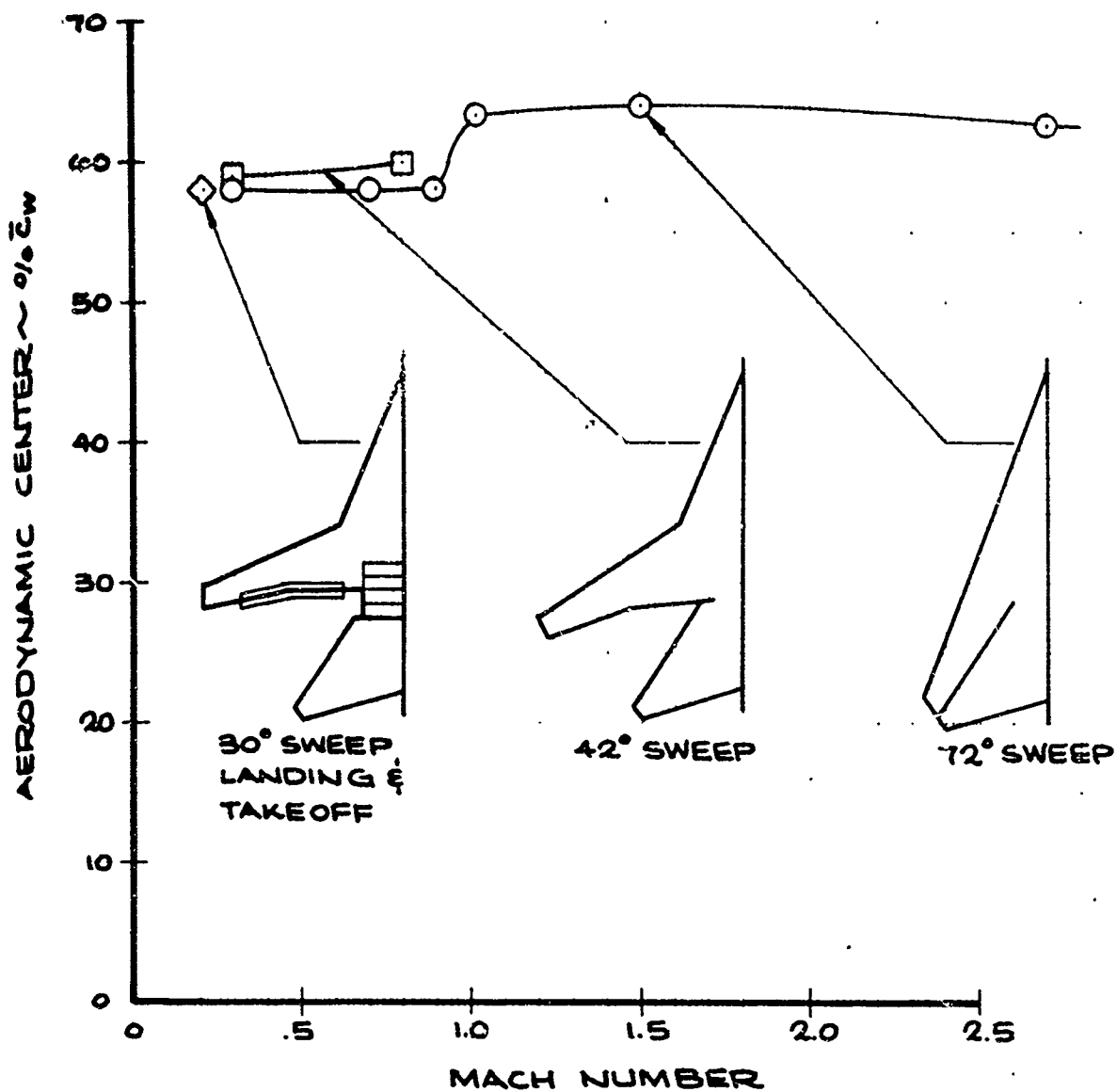


Figure 10. Aerodynamic Center Locations - Wind Tunnel Data (Rigid Airplane)

D6-18110-5

**CRITICAL STABILITY  
NEUTRAL POINTS,  
ELASTIC AIRPLANE**

DATA OBTAINED FROM: UVAL 857  
 FSWT 965 & 467  
 BSWT 349 & 353

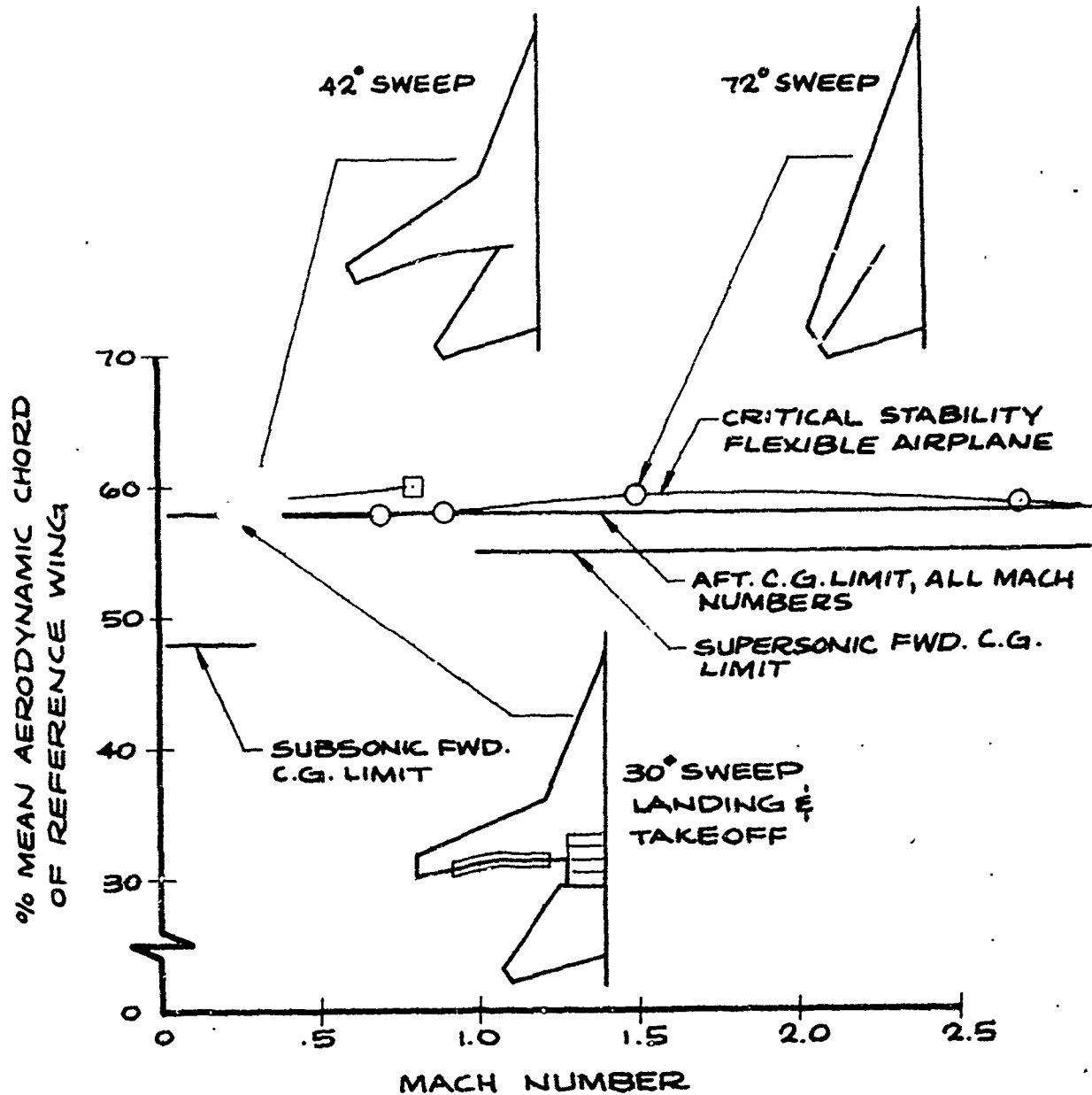


Figure 11. Flexible Airplane, Static and Maneuver Neutral Points

### III. Description of Technical Progress (continued)

#### 10023. Stability and Control (continued)

reference wing for all operating conditions. This appears to be warranted by the preliminary analyses of the flexible airplane critical stability conditions. Initial wind tunnel test data and structural aeroelastic analyses indicate that maneuver stability will be critical at maximum dive speeds at supersonic conditions, and that static stability will be critical at subsonic, wings-aft conditions. In maneuvering flight at supersonic dive speeds, the maneuver neutral point of the flexible airplane is about 4 percent M.A.C. forward of the rigid airplane static neutral point. In this case the destabilizing forward shift of the aerodynamic center of the flexible wing is greater than the stabilizing effect of tail damping and tail angle-of-attack increase with load factor due to aft body bending (tail  $d\alpha/d\dot{\alpha}$ ). At subsonic speeds the tail stabilizing effect with damping and the tail  $d\alpha/d\dot{\alpha}$  characteristics predominate over the destabilizing effect of wing bending during maneuvering, resulting in the maneuver neutral point being aft of the static neutral point, and therefore not critical in the selection of the aft C.G. limit. As shown in Fig. 11, these differences in the elastic airplane stability characteristics between subsonic and supersonic conditions result in little variation of the critical stability neutral points with Mach number, permitting a single aft C.G. limit for all conditions.

It may also be seen in Fig. 11 that neutral static stability has been selected as a criterion for determining the aft center-of-gravity limit. Flight simulator experiments and analyses have shown no deterioration in the handling qualities of the unaugmented airplane as the stability margin is reduced from about +4 percent M.A.C. to -2 percent M.A.C. Thus provision of a 3 or 4 percent static margin offers no improvement in airplane handling over that provided with zero static margin. These characteristics have been found to be typical of large, high-inertia configurations which are characterized by sluggish longitudinal response characteristics. Stability augmentation is required to improve the airplane response in the longitudinal mode. The stability augmentation system being developed for the B-2707 airplane will provide good longitudinal handling qualities with quick response and proper variations of stick force with speed and g variations from trim.

### III. Description of Technical Progress (continued)

#### 10023. Stability and Control (continued)

Figures 12 through 15 show longitudinal stability characteristics typical for the B-2707 configuration as measured in preliminary low-speed, transonic, and supersonic wind tunnel tests. Landing configuration characteristics are shown in Fig. 12 for the basic flap and leading-edge slat arrangements (wing sweep 30 degrees). Nearly linear stability exists up through the wing-body stall ( $\alpha$  about 19 degrees and  $C_L$  near 1.8, uncorrected for scale effects), with strong pitch-down occurring after stall for angles-of-attack up to 33 degrees. An unstable  $dC_m/dC_L$  slope exists for angles-of-attack between 33 and 40 degrees, or 14 to 21 degrees above the wing stall angle-of-attack. Improvements in these stall and high angle-of-attack stability characteristics are desired and will be developed in future wind tunnel testing. Figure 13 shows the excellent stability characteristics attainable with modification of the strake (fixed portion of wing). Here the tip (outer 1/3) of the strake was folded up 90 degrees, simulating a hinged portion interconnected with the wing flaps. This configuration provided linear stability through the stall followed by strong pitch-down for angles-of-attack above stall up to the highest angle tested, 40 degrees.

Figures 14 and 15 show transonic and supersonic stability characteristics measured at 42 degrees and 72 degrees wing sweep with a model which closely approximated the B-2707 airplane. In all cases stability is seen to be essentially linear with no evidence of pitch-up problems throughout the operational range of lift coefficients through and beyond structural limits.

#### 10024. AERODYNAMIC WIND TUNNEL TESTS

Selection of the B-2707 configuration has resulted in changes in the aerodynamic wind tunnel test schedule. Several model test programs have been cancelled and construction has been initiated on new high-speed and low-speed configuration development models. Tests completed during April and May and tests planned for June and July are shown on the schedule chart, Fig. 16.

Three low-speed wind tunnel tests were completed during March, April, and May. Two were preliminary investigations of the stability, control, and performance characteristics with large horizontal tail surfaces, in a landing configuration with a wing sweep angle of 20 degrees. Tail size, vertical, and fore-and-aft location studies (with respect to the wing) were made. These showed that an integrated wing-tail concept for high-speed flight is compatible with good stability and performance at low-flight speeds.

LONGITUDINAL STABILITY  
 CHARACTERISTICS  
 LANDING CONFIGURATION  
 $\alpha_{L.E.} = 30^\circ$

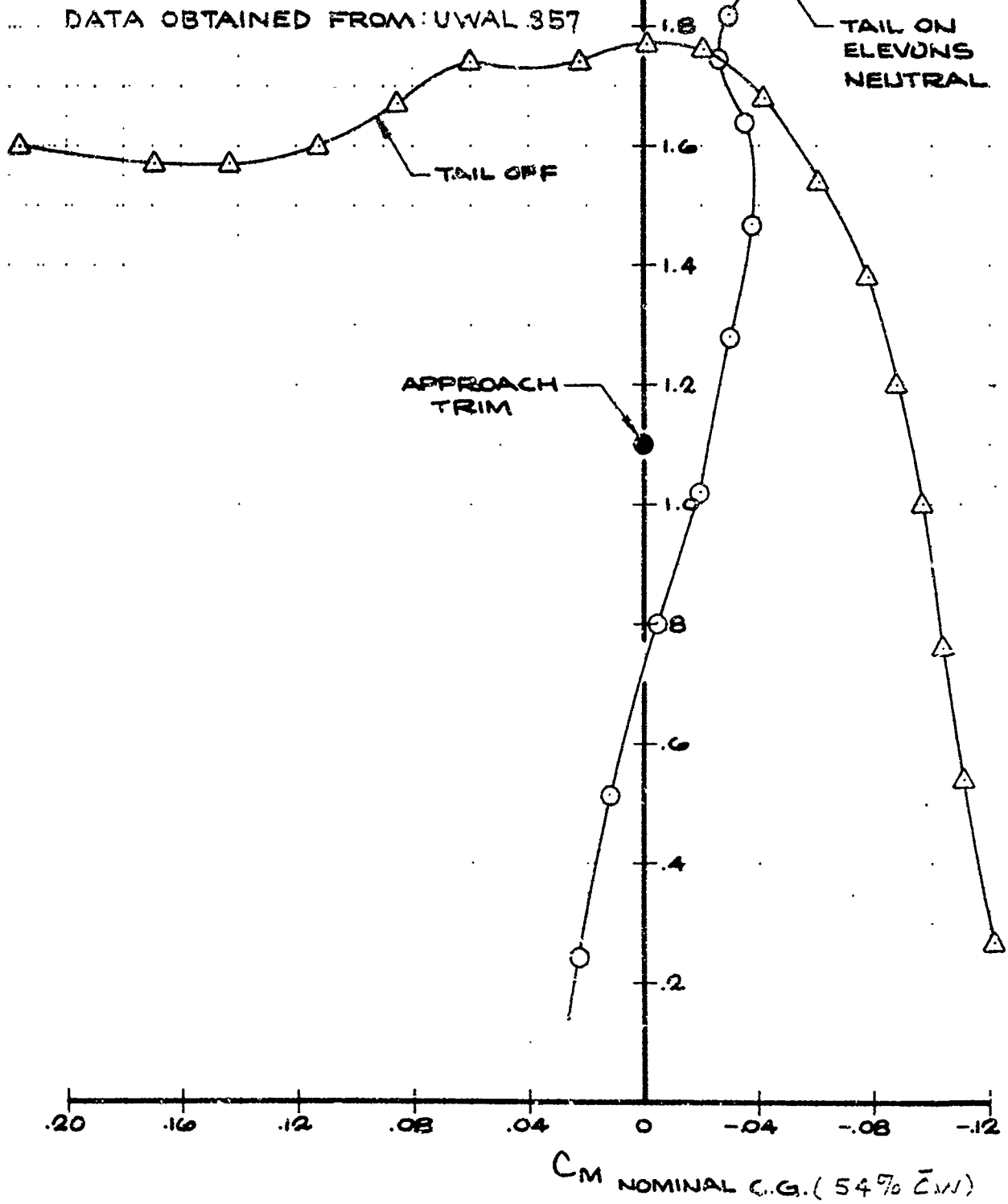


Figure 12. Longitudinal Stability, Landing Configuration

D6-18110-5

EFFECT OF STRAKE TREATMENT  
LANDING CONFIGURATION

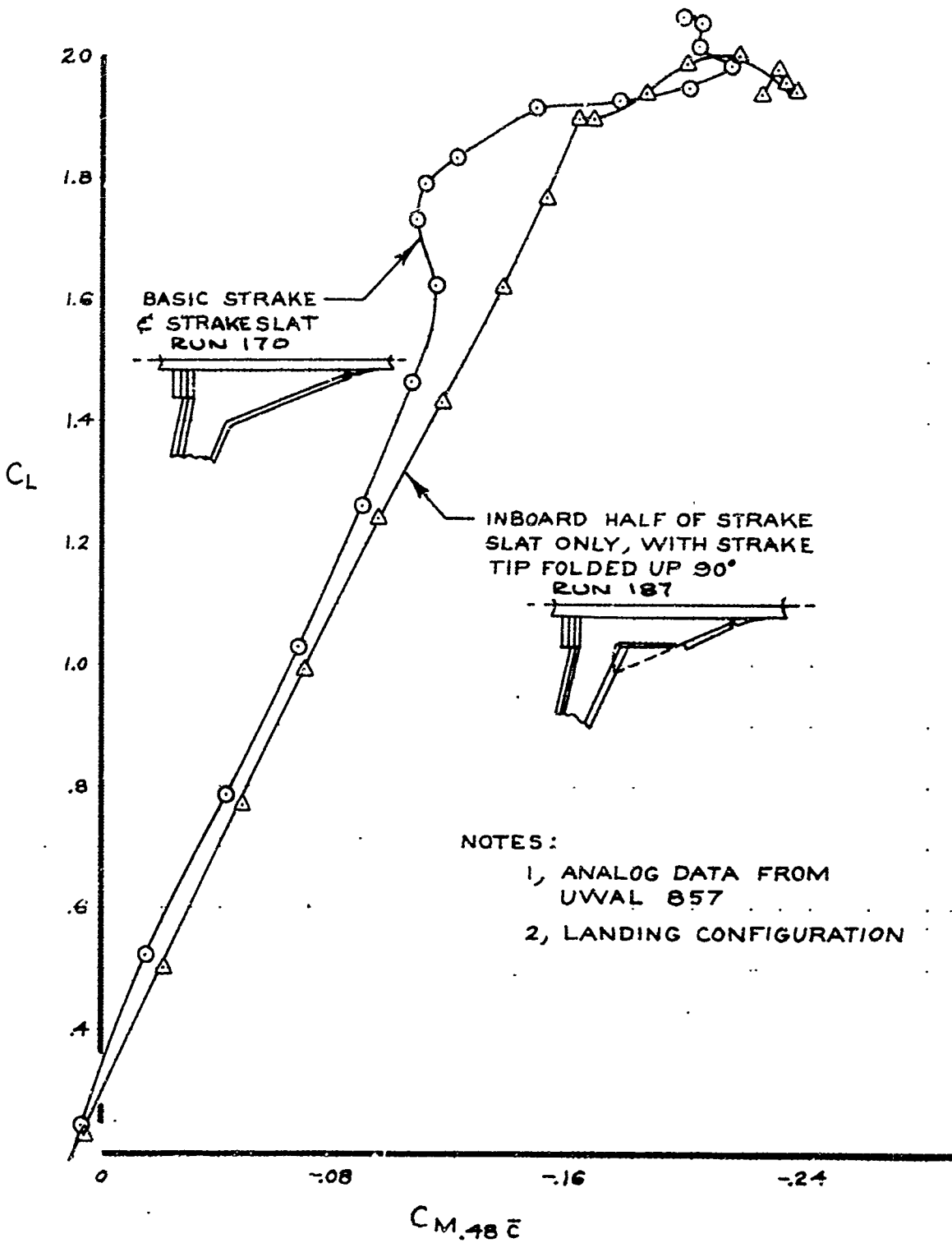


Figure 13. Strake Modification to Improve Flaps-Down Stability

D6-18110-5

LONGITUDINAL STABILITY  
 CHARACTERISTICS  
 CLEAN CONFIGURATION  
 $\Lambda_{LE} = 42^\circ$   
 $M = .90$

DATA OBTAINED FROM  
 BTWT. 965 & 967

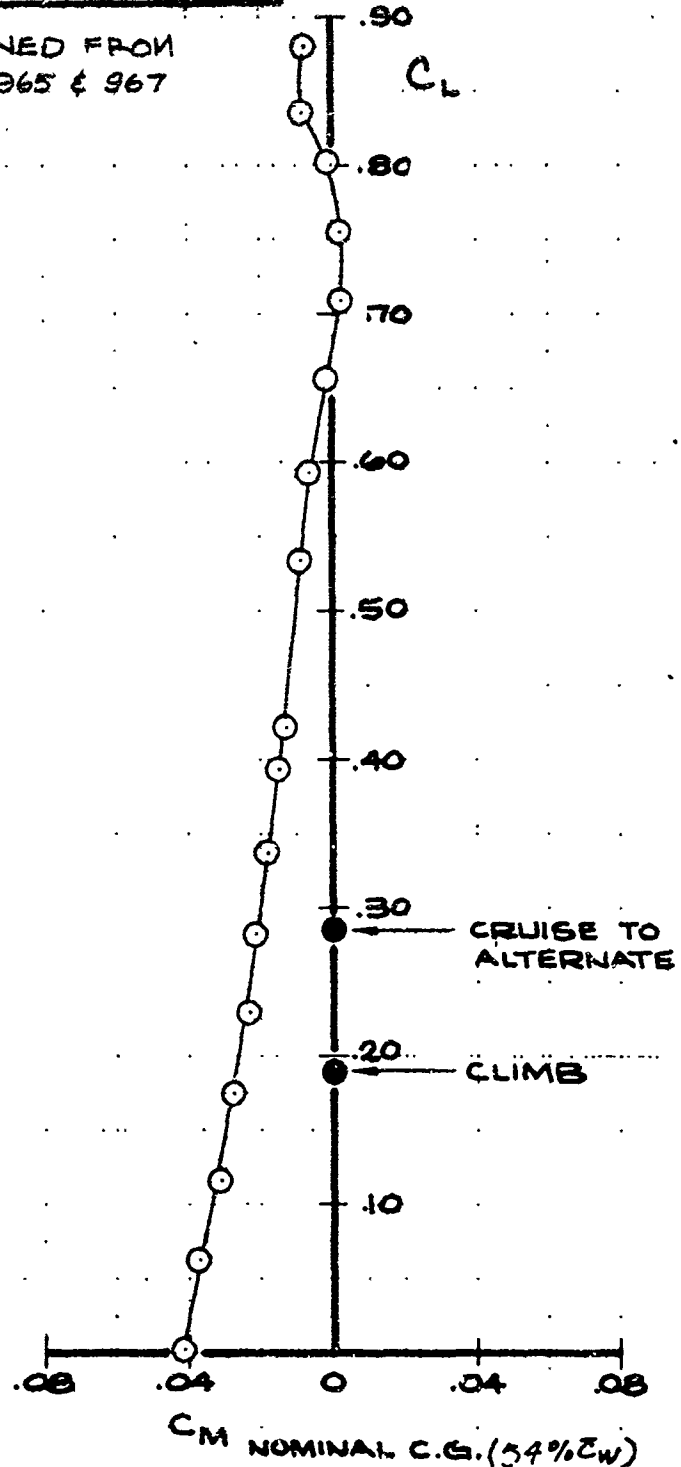


Figure 14. Transonic Longitudinal Stability Characteristics,  $\Lambda_{LE} = 42$

D6-18110-5

LONGITUDINAL STABILITY  
 CHARACTERISTICS  
 CLEAN CONFIGURATION  
 $\Lambda_{LE} = 72^\circ$

DATA OBTAINED FROM  
 BTWT 965 & 967  
 BSWT 349 & 353

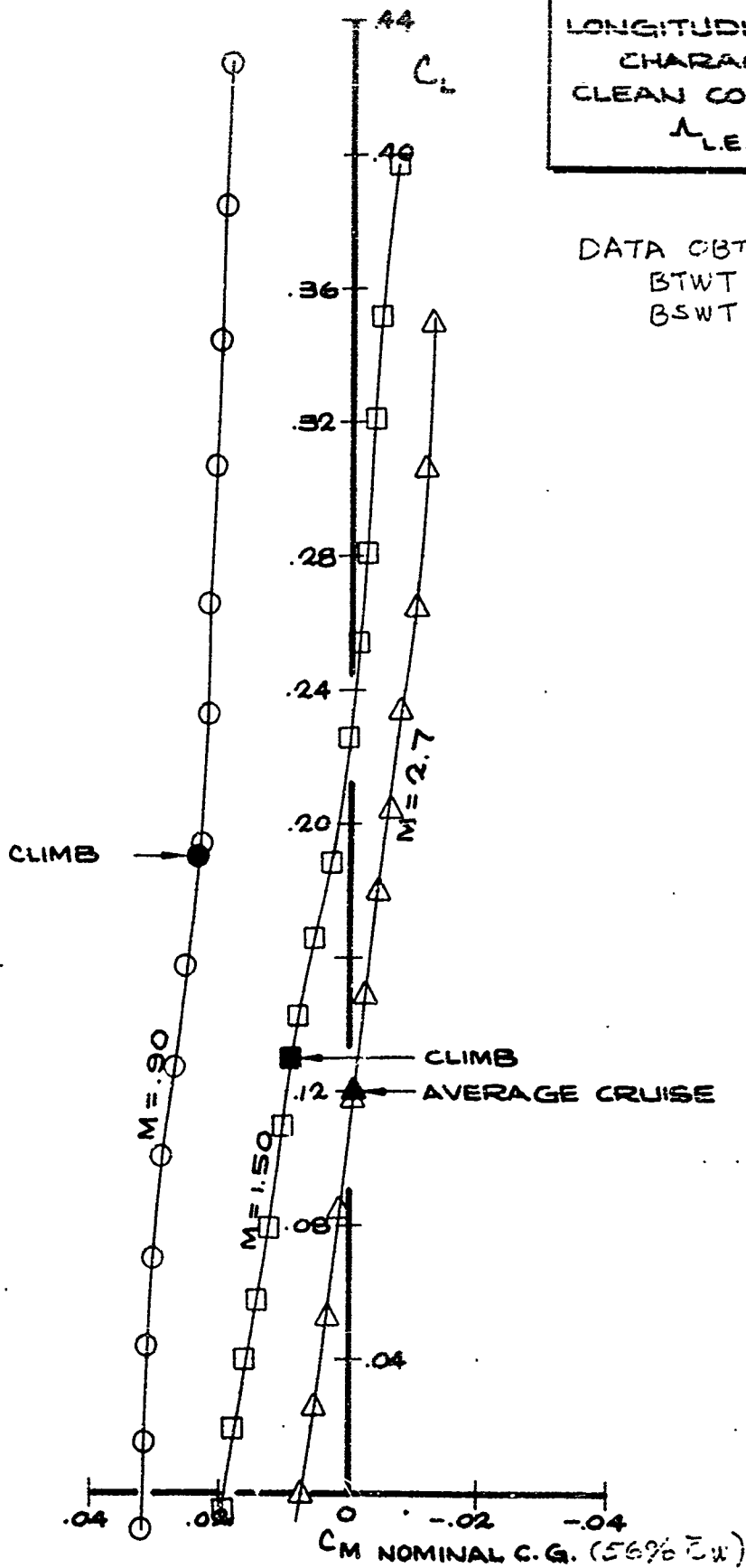


Figure 15. Longitudinal Stability Characteristics,  $\Lambda_{LE} = 72$

D6-18110-5

WIND TUNNEL MODEL		APRIL	MAY	JUNE	JULY	
NUMBER AND DESCRIPTION						
LOW SPEED	SA 857 E-8 Initial B-2707 Configuration Tests		■ UWAL 857			
	SA-868 M-4 Strake L.E. Blowing Tests		■ BIWT 970			
	SA 857 E-10 B-2707 Configuration Development Tests. Takeoff and Landing Configurations			□	□	
	SA 967 E-1 New Low Speed Model of B-2707 for Takeoff and Landing Performance, Stability and Control Testing				□	
	SA 868 M-4 Second L.E. Blowing Test, Strake and Outboard Wing. Integrated Wing-Tail Configuration				□	
TRANSONIC	SA-948 I-1 733-414 and Alternate Planform Evaluation	■ BIWT	961			
	SA 840 D-2 Elastic Wing Model Tests	■ Cornell				
	SA 841 I-19 Initial B-2707 Drag and Stability Tests = 72°	BIWT		965		
	SA 840 I-3 Initial B-2707 Drag and Stability Tests with Wing Sweep Angles of 30° and 42°	■ BIWT		967		
	SA 856 I-11 B-2707 Drag, Stability and Control Tests for Three Wing Sweep Angles			□	□	
			Tests Completed		Tests Scheduled	

Figure 16. Aerodynamics Wind Tunnel Test Schedule

D6-18110-5

WIND TUNNEL MODEL		APRIL	MAY	JUNE	JULY	
NUMBER AND DESCRIPTION						
SUPERSONIC	SA-948 I-1 733-414 and Alternate Plan- form Evaluation	.0173 Scale	■ BSWT	345B		
	SA-841 I-18 Close-Coupled Tail Tests	.0164 Scale	■ ■	BSWT 347, 350		
	SA-945 I-1 Yoke Sting, Body Closure Tests	.0164 Scale	■	BSWT 348		
	SA-841 I-19 Initial B-2707 Drag and Stability Tests	.0162 Scale	■ ■	■ BSWT 349, 353		
	SA-449 I-7 Canopy Frag Tests	.05 Scale	■	BSWT 351		
	SA-945 I-1 Yoke Sting, Body Closure Tests	.0164 Scale		■ BSWT 355		
	SA-841 I-21 B-2707 Nacelle Shape, Position and Integration Tests	.0164 Scale		■ □ BSWT 356		
	SA-841 I-20 Longitudinal and Directional Stability and Control Tests	.0164 Scale		■ □ BSWT 357		
SA-966 I-1 New B-2707 Configuration Development Model	.015 Scale			□ □ □		
			Tests Completed		Tests Scheduled	

Figure 16. Aerodynamics Wind Tunnel Test Schedule (continued)

D6-18110-5

### III. Description of Technical Progress (continued)

#### 10024. Aerodynamic Wind Tunnel Tests (continued)

The wind tunnel model, SA 857 E-8, represents the B-2707 airplane configuration. Triple and double slotted flaps were tested at a wing sweep of 30 degrees. Pitch control power and performance was evaluated in free air and in ground effect. A photograph of the model with ground board is shown in Fig. 17.

High speed tests to complete the evaluation of the 733-414 configuration were completed in early April. Since that time transonic and supersonic testing has focused on investigations of the stability and control characteristics of large integrated tail configurations. Results of these tests have shown excellent high speed stability characteristics and a substantial drag advantage at cruise for the integrated wing-tail concept. The two most recent transonic and the three most recent supersonic test periods have used revised existing models for evaluation of the B-2707 configuration at wing sweep angles of 30, 42, and 72 degrees. Photographs of two of these models are shown in Figs. 18 and 19.

In addition an initial supersonic aft body closure drag test using a "yoke" sting was completed as was a series of transonic tests on the elastic wing model. The elastic wing tests were carried out in the Cornell variable-density transonic wind tunnel facility.

The total aerodynamics wind tunnel test time for April and May amounted to 1009 hours. The following test programs were completed:

UWAL Test Number 857, SA-857 E-8, 0.036 scale model. Tested May 5 through 11. Purpose: Evaluate double and triple slotted flap systems and obtain longitudinal stability and control power data in free air and in ground effect.

BTWT Test Number 970, SA-868 M-4, 0.055 scale model. Tested May 11 through 13. Purpose: Evaluate the use of leading edge strake blowing for improving low speed stability and performance.

BTWT Test Number 961, SA-948 I-1, 0.0173 scale model. Tested March 31 through April 4. Purpose: Evaluate the transonic performance of the 733-414 configuration and an alternate wing planform.

Cornell Aero Laboratory Test, SA-840 D-2, 0.0164 scale elastic wing model. Tested April 4 through 7. Purpose: Evaluate wing aero-elastic effects at transonic speeds.

BTWT 965 A and B, SA-841 I-19, 0.0162 scale model. Tested April 21 through 22 and April 30. Purpose: Evaluate transonic stability and performance characteristics of integrated wing-tail configurations with wing sweep of 72 degrees.

D6-18110-5



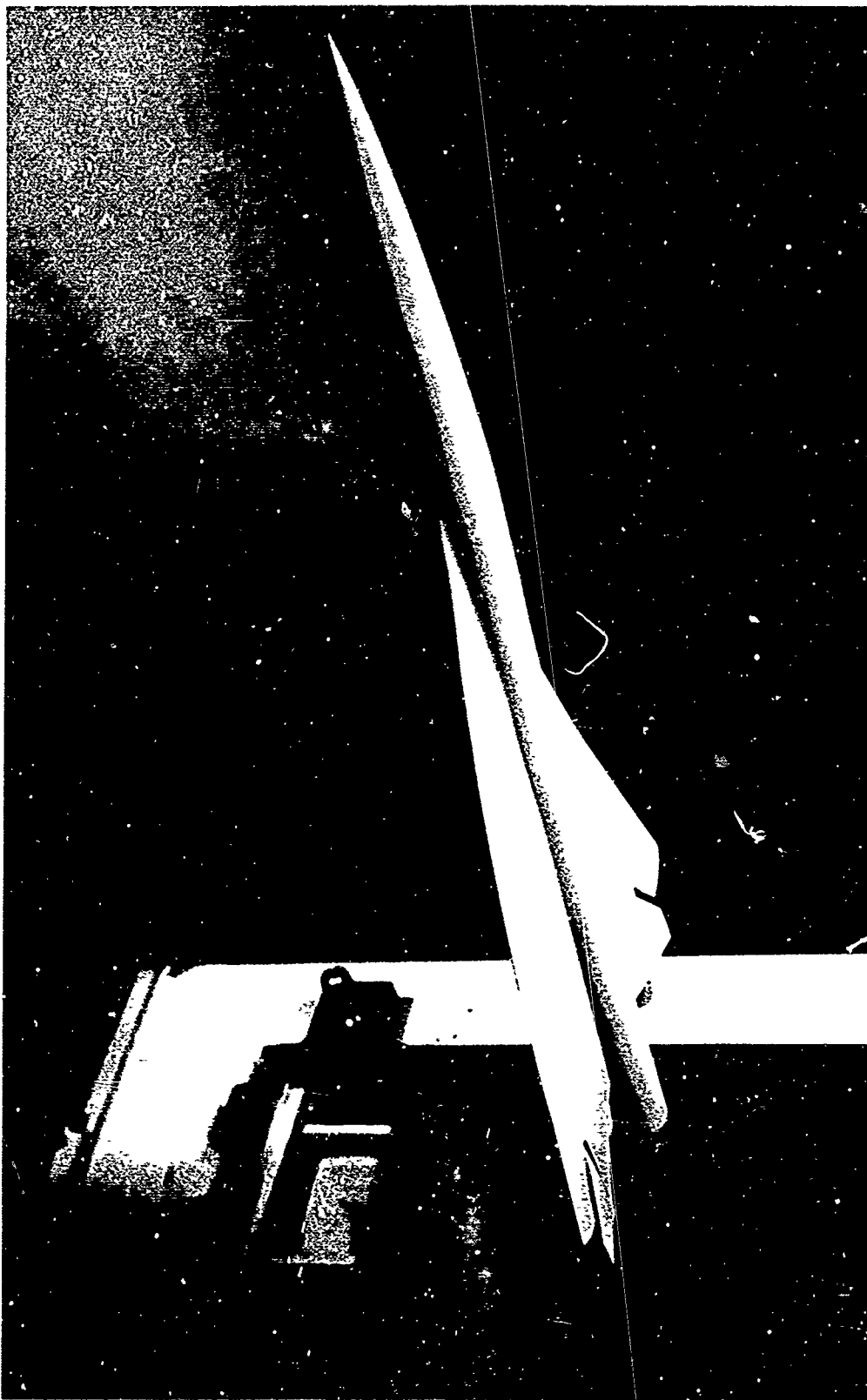
Figure 17. Low-Speed Configuration Development Model WS = 30°

D6-18110-5



Figure 18. Transonic Configuration Development Model WS = 42

D6-18110-5



*Figure 19. Supersonic Configuration Development Model,  $WS = 72^\circ$*

D6-18110-5

### III. Description of Technical Progress (continued)

#### 10024. Aerodynamic Wing Tunnel Tests (continued)

BTWT 967, SA-840 I-3, 0.0156 scale model. Tested April 30 through May 2. Purpose: Evaluate the transonic stability and performance of the B-2707 type configuration with wing sweeps of 30 and 42 degrees.

BSWT 345B, SA-948 I-1, 0.0173 scale model. Tested April 5 through 7. Purpose: Evaluation of supersonic performance of the 733-414 configuration and an alternate wing planform.

BSWT 347 and 350, SA-841 I-18, 0.0164 scale model. Tested April 13 through 14 and April 21 through 23. Purpose: Evaluation of large integrated tail configurations.

BSWT 349 and 353, TA-841 I-19, 0.0162 scale model. Tested April 18 through 27 and May 4 through 6. Purpose: Evaluation of the supersonic performance and stability characteristics of B-2707 type configuration.

BSWT 348 and 355, TA-945 I-1, 0.0164 scale yoke sting mounted model. Tested April 15 through 16 and May 19 through 20. Purpose: Develop a model support system for measuring aft body closure drag at supersonic speeds.

BSWT 351, SA-449 I-7, 0.05 scale canopy model. Tested April 23 through 25. Purpose: Canopy drag evaluation.

BSWT 356, TA-841 I-21, 0.0164 scale model. Tested May 23 through 27. Purpose: Nacelle drag studies for the B-2707 configuration.

BSWT 357, TA-841 I-20, 0.0164 scale model. Tested May 31 through June 1. Purpose: Longitudinal and directional stability and control effectiveness tests for B-2707 configuration.

Aerodynamic testing during June and July will continue to employ existing models revised to refine and develop the B-2707 configuration. New high-speed and low-speed models of the B-2707 are under construction. First supersonic tests with the new supersonic model SA-966 are scheduled for late June. Construction of the evaluation wind tunnel models to be supplied to the FAA will start about July 1.

#### 1003. Maintainability

The maintainability organization has been reorganized and expanded to provide more emphasis on design support. Mr. L. J. Onewein has been appointed by the Maintainability Unit Chief. Currently, the unit manpower stands at 20 personnel, including 10 personnel assigned to and located with each of the subsystems design groups.

D6-18110-5

### III. Description of Technical Progress (continued)

#### 10030. GENERAL

An improved maintainability section has been prepared for the model specification. Included are the design objectives, maintainability goals for the through service and turnaround services, unscheduled maintenance check goals for daily checks, intermediate checks, periodic checks and basic checks and maintenance cost estimates and basic test and checkout philosophy.

Maintainability sections for the following subsystems specifications have been prepared: aircraft integrated data, accessory drive, starter, passenger and cargo accommodations, environmental control, and windshield anti-icing and anti-fogging subsystems. Inputs included maintenance philosophy, quantitative and qualitative design objectives, and basic test and checkout philosophy.

Preliminary SST maintenance cost and maintenance manhour allocations have been established to the subsystem level, based on commercial 707 and 720 cost and manhour data. Maintenance cost, not including burden, was divided between labor and material. Maintenance manhours per flight hour have been calculated using labor cost. These data are being used as the basis for quantitative inputs to subsystem specifications.

The airline operations and maintenance simulation model has been completely checked out. Data is now being developed to allow the evaluation of overall SST system maintainability.

Trips to Pan American, American and United were made to discuss maintenance requirements for the SST with their maintenance executives and lead personnel.

A trip was conducted to review the General Electric and Pratt and Whitney AIDS studies, the onboard test and checkout research program being conducted by IBM and Eastern Airlines, and the status and results of the TWA engine monitoring system.

Both the Reliability, Safety and Maintainability Plan, D6-17612, and the Product Controls Management System Information, D6-18250, have been updated.

A series of one page test plan summaries has been prepared to establish maintainability test and data requirements. These test plans included the following data requirements: time of occurrence of the maintenance action, a description of the work accomplished, the test time to accomplish the actual work, number and skill of personnel required, tools required, test and checkout equipment or other GSE required, and additionally in the case of failure, the test and checkout time and the part or parts replaced.

### III. Description of Technical Progress (continued)

#### 10031. DESIGN SUPPORT

Maintainability reviews have been accomplished and requirements have been prepared for 26 procurement specifications. These reviews consisted of comments on technical requirements in addition to the definition of maintainability design objectives, maintenance concept, maintainability analysis, maintainability goals, reporting requirements, and test and checkout requirements.

The maintainability group is participating in the evaluation of vendor proposals. These proposals are evaluated against the requirements of the procurement specification and supporting documentation. Evaluation scores and substantiating comments are recorded.

During this reporting period, trade studies have been accomplished on the fire detection system, the auxiliary drive system, lubricating oil system, the airplane ground contact indicator system, the location of the external power receptacle, and the heat exchanger module package concept.

#### 10032. MAINTENANCE ANALYSIS

The design support engineers assigned to and located physically with the subsystem design groups are accomplishing a maintainability analysis. Procedures and formats have been established which, when the final iteration has been completed, will result in a systematic analysis of each line replaceable unit (LRU) for maintainability and support requirements. The LRU analysis results in the determination of satisfactory maintainability characteristics, defines support requirements, and provides design guidance and requirements to the designer.

The maintainability analysis is organized into three prime efforts: ground handling and servicing, scheduled maintenance, and unscheduled maintenance. The functional flow diagrams governing the analysis have been completed. Requirements allocation sheets providing design requirements and task-time analyses for the ground handling and servicing effort are nearly completed.

General requirements for the schedule maintenance effort have been completed and will be expanded by the unscheduled, detailed maintenance sheets and associated requirements allocation sheets.

#### 10033. MAINTAINABILITY STUDIES

The AIDS feasibility and requirements study is progressing as planned. The AIDS studies have been carried to the point of listing all presently known subsystems and LRU's. A preliminary indication of those systems requiring AIDS monitoring has been made, utilizing failure rate information on current commercial aircraft. A further study of the sampling frequency necessary, as well as the total test points to be monitored, has been made to determine the capabilities required in the AIDS.

D6-18110-5

### III. Description of Technical Progress (continued)

#### 10033. Maintainability Studies (continued)

These data have been tabulated and transmitted to the project groups concerned for their comments and for updating to the latest configuration.

#### 1004. Reliability

##### 10040. RELIABILITY GENERAL

The reliability organization is presently staffed at a level of 29, which includes 27 technical personnel. A manpower level of 34 is expected during June, July, and August.

The following completions are noted for the reporting period, April - May:

- Review and revision of the Phase II-C Reliability, Safety, and Maintainability Plan, D6-17612.
- Review and revision of the Reliability Task Lists contained in the Product Controls Management System Information document, D6-18250.

During this reporting period a trade study was made of equipment configurations that are believed to provide capability for landing under Category II, IIIA, and IIIB weather conditions. Factors considered in the study were: (1) the probability of occurrence of such weather at North Atlantic gateway destinations served by Pan American World Airways; (2) the reliability of the equipment; (3) acquisition costs; (4) maintenance costs; and (5) diversion penalty costs. Results of the study have been presented to Pan American World Airways on May 5, and to Maj. E. R. Highfield, FAA, on May 27. An interim report on this study is scheduled for June 20, 1966.

A reliability presentation was made to SST supervision during the reporting period covering:

- Identification of reliability commitments
- Description of responsibilities and working relationships in reliability activities
- Technical and management documentation planned to provide uniform guidance.

##### 10041. RELIABILITY DESIGN SUPPORT

The following reliability analysis documents have been released during the reporting period:

- D6A10064-4 - Automatic Flight Control System - SST, Reliability Analysis
- D6A10064-7 - Environmental Control System - SST, Reliability Analysis

D6-18110-5

### III. Description of Technical Progress (continued)

#### 10041. Reliability Design Support (continued)

These are initial releases. They will be updated as required to support the design and development of the respective system elements. They have been prepared by project design personnel with direct assistance from reliability design support specialists.

The following subsystem specification drafts were reviewed for adequacy of the reliability inputs:

- D6A10107-1 - Airframe Subsystem
- D6A10108-1 - Landing Gear Subsystem
- D6A10089-1 - Accessory Drive Subsystem
- D6A10111-1 - Propulsion Subsystem
- D6A10115-1 - Fire Detection-Extinguishing
- D6A10116-1 - Fuel Subsystem
- D6A10118-1 - Air Induction Control Subsystem
- D6A10117-1 - Engine Inlet Anti-Icing Subsystem
- D6A10121-1 - Environmental Control Subsystem

Reliability inputs were made to the following procurement specifications:

- 60A10016 - Wing Sweep Actuator
- 60A10026 - Wheel and Brake Assembly
- 60A10027 - Hydraulic Reservoir
- 10-61080 - Glide Slope and Localizer Receiving System
- 10-60977 - Displays, Integrated Flight Instruments
- 10-60980 - Automatic Flight Control System
- 10-60975 - Inertial Navigation System
- 10-60978 - Air Data Computer

Four supplier proposals each for the engine driven hydraulic pump and the lateral master servo control were evaluated and ranked with respect to the adequacy of technical and program reliability approaches.

#### 10042. RELIABILITY ANALYSIS

##### (a) Reliability Apportionment

The airplane reliability objectives have been reapportioned to Work Breakdown Structure level 3 descriptions. These values will be used in subsystem specifications.

D6-18110-5

### III. Description of Technical Progress (continued)

#### 10042. Reliability Analysis (continued)

##### (b) Failure/Error Mode Effect and Criticality Analysis

The forms for these analysis have been revised and instructions have been developed for their preparation. These instructions have been prepared for release by the Chief Engineer at an early date.

##### (c) Mathematical Models

Evaluation of existing Boeing reliability models has been completed and the maintainability and reliability cost effectiveness program (MARCEP) model, with modification, has been selected as being capable of producing the results necessary for optimizing SST inflight reliability. Data inputs are being assembled and initial results will be available soon.

Efforts are continuing on development of a fleet reliability simulation model based on expected airline route structures, schedules, ground time, maintenance task completion distributions, and fleet sizes. The purpose of this model is to evaluate and determine the reliability capabilities of the SST as used in typical airline operations. The model will provide inputs to and accept outputs of the maintainability simulation model.

##### (d) Test Plan Review

Approximately 1700 one-page test plan summaries have been reviewed for adequacy of coverage for reliability data purposes. Recommended changes were provided for approximately 1000 of these summaries where the coverage was considered inadequate for reliability.

##### (e) Critical Item List

The initial listing of critical items was prepared and distributed. This list is preliminary and considered "in-flight reliability criticality" for items the failure of which could either alone or in a reasonable, logical combination with other failures, result in a flight deviation or turnback.

##### (f) Minimum Equipment List

Tentative Minimum Equipment Lists are being assembled. These list the quantity of an item on the airplane, and the minimum quantity required for dispatch for various flight conditions as well as the minimum quantity required to continue various flights.

(g) The initial release of Reliability Analysis Document D6A10064-1 for the System and Air Vehicle occurred during this period.

### III. Description of Technical Progress (continued)

#### 1004. DESIGN SUPPORT DATA CENTRAL

The Design Support Data Central Staff has continued to collect, analyze, and disseminate airplane service data in support of reliability, maintainability, and safety analyses.

Documentation of aircraft service failure rate standards and historical problem summaries is continuing. Preliminary release was made of the document "Aircraft Historical Problem Analysis." The hydraulic, pneumatic, navigation and landing gear systems have been analyzed to determine the subsystems and/or components which caused flight delays, flight cancellations or flight turnbacks in the 727 aircraft. The remaining aircraft systems are being investigated. This information was distributed to reliability analysts and designers so that design steps may be taken to prevent recurrence of similar problems on the SST.

Coordination with the Quality Assurance and Operations Organizations is continuing in the development of the failure and problem reporting and corrective action system for the SST Program. Inputs were made to the Phase II-C revised reliability, maintainability, and safety program plan released in May.

Three people were added to the SST Design Support Data Central staff in April, two in May, and four more are providing full time support from the Space Division Data Central. This increases the number of personnel in the Data Support effort to 17.

#### 1005. Value Engineering

Cost analyses have been completed on the following Value Engineering studies:

##### VE 733 H6

A comparison of two design concepts for nose-gear steering: mechanical-hydraulic, and electro-hydraulic. The cost analysis indicated that the mechanical-hydraulic system is less costly by approximately \$500,000 for 100 airplanes.

##### VE 733 E10

A comparison of two design concepts for the landing gear indicating and warning circuit, one employing solid-state circuitry, and the other employing microminiature relays. The cost analysis indicated that the solid-state circuitry method is less costly by approximately \$4000 for 100 airplanes.

D6-18110-5

III. Description of Technical Progress (continued)

1005. Value Engineering (continued)

VE 733 B18

An estimate of various component costs concerning airplane survivability and crew escape for two prototype airplanes:

Instrumentation, telemetry and TV monitoring	\$ 54,600
Flight deck pressure integrity	257,300
Drogue parachute system	704,300
Manual bailout	503,200
Open ejection seat	3,513,000
Encapsulated seat	9,452,000

VE 733 LG2

A comparison of alternative materials and fabrication methods for the outer cylinder of the main-landing-gear telescopic-tube assembly:

<u>Description</u>	<u>Cost per 2 Prototype Airplanes</u>	<u>Cost per 100 Production Airplanes</u>
Two 4340 M Steel forgings, flash welded 270-300 KSI heat treat	\$198,000	\$3,465,000
Two Ti-6Al-6V-2Sn forgings, flash welded 160-180 KSI heat treat	344,600	10,985,000
Two 4340 M steel forgings, pressure welded 270-300 KSI heat treat	198,000	3,465,000
Two Ti-6Al-6V-2Sn forgings, pressure welded 160-180 KSI heat treat	344,600	10,985,000
One-piece forging, 4340 M steel, forged solid and rough bored to 16.25 inch dia.; final heat treat 270-300 KSI	153,600	2,641,000

Additional Value Engineering studies now in progress include:

VE 733 B19

A comparison of two fuselage shapes, in which respectively 20 percent and 75 percent of the surface is generated from straight-line elements.

### III. Description of Technical Progress (continued)

#### 1005. Value Engineering (continued)

##### VE 733 E5

An evaluation of the savings by use of minimum electrical ground leads.

##### VE 733 E6

An evaluation of the savings from deletion of the forward electrical buses.

##### VE 733 EM8

A cost comparison of five structural sections--tees, angles, zees, hats, and channels---each fabricated, where applicable, by five alternative methods: fully machined extrusion, fusion welding, cold-formed sheet, hot-formed sheet, or hot-sized cold-formed sheet.

##### VE 733 H5

A comparison of two methods of fabricating hydraulic tube ends:

- (1) Upset tube-ends and machine.
- (2) Machine separate end fittings and weld to tube.

##### VE 733 W13

A comparison of outboard wing ribs:

- (1) Conventional webs and stiffeners.
- (2) Electron beam welding of corrugated webs to flanges.
- (3) TIG welding of corrugated webs to flanges.

The final draft of the SST Design Cost Objectives Document D6A10127-1 has been prepared. For its initial release, the document will consist of cost information obtained from the Cost Baseline Report (D6-14034 and D6-14034-1). This information will be presented in barcharts and graphs and amplified by text. The charts were shown to Mr. J. J. Gwiazdowski of the FAA, together with an oral presentation on April 26. The comments were useful in improving the final draft.

D6A10127-1 is scheduled for publication in early June, 1966, in brochure format and will be distributed to all design engineering personnel. A combined oral-viewgraph Design Cost Objectives presentation has been prepared and will be given to design supervisors.

A standard Value Engineering Incentive Agreement, 6M673, has been prepared for inclusion in all procurement contracts in excess of \$100,000.

D6-18110-5

### III. Description of Technical Progress (continued)

#### 1005. Value Engineering (continued)

Requests for Proposal SST-1 and SST-6 being forwarded to sub-contractors and suppliers will include requests for a Value Engineering program definition. The inputs will be used to establish overall sub-contractor and supplier Value Engineering programs.

The third of eight scheduled 32-hour value engineering training seminars was conducted in April. The seminar, under the direction of Value Analysis, Inc., was attended by 59 persons assigned to the SST program from Engineering, Manufacturing, Materiel, Finance and Quality Control. The Value Engineering Plan, D6-17611, for Phase II-C is being revised. The revised document will be released in June, 1966.

#### 1007. Product And System Safety

##### 10070. SAFETY GENERAL

Mr. J. E. Huffington has been assigned as the Safety Engineering Unit Chief. In addition, three safety engineers have been added to the safety unit, bringing the organizational strength to nine.

##### 10071. DESIGN SUPPORT

Safety requirements were established for five preliminary procurement specifications. These requirements include detailed design requirements as well as specific safety management plans.

Safety evaluation of subcontractor proposals was begun with the review of four proposals for hydraulic pumps. These evaluations are documented in summary form and transmitted to the appropriate design organization.

The evaluation considers the proposal from two standpoints: (1) the management plan proposed to ensure that safety is given due consideration in design and manufacture; (2) the technical design details and their effect on safety.

#### 1008. Materials And Processes

##### Integral Fuel Tank Insulation

Dynamic testing of the prime candidate material for insulating the wing integral fuel tanks is in progress. Minnesota Mining's XA 5910 low density insulation coating has been applied to titanium panels simulating the applicable structure. Panels now in test have been subjected to approximately 48,000 cycles of tension-compression loading without any cracking, loss of adhesion or evidence of physical change

### III. Description of Technical Progress (continued)

#### 1008. Materials and Processes (continued)

in the insulation. Both working loads and design limit loads have been applied. Testing will continue in order to establish the fatigue life of the insulation at service temperature extremes under the influence of cyclic fuel and heat exposure.

A backup material, a Boeing formulated polyurethane foam (of 10 pounds per cubic foot density) is being subjected to cyclic aging in fuel at 250°F for three days and in a nitrogen-fuel vapor mixture at 400°F for four days. After two cycles the volume loss was 12 percent and the weight loss 14 percent. Eight more aging cycles then caused no visible change.

#### Fuel Containment

Functional testing to establish the service life of proposed integral fuel tank sealants is continuing. A test plate sealed with 3M's EC-2332 faying surface sealant was leak free after 3360 hours of cyclic environmental exposure and 140 shear loading cycles. A second test plate sealed with Dow Corning's Q94-002 fillet sealant failed the leak test after the same conditioning and testing listed above. A third test plate sealed with Dow Corning's Q94-508 faying surface sealant was leak free after 1000 hours of cyclic exposure and 80 shear loading cycles. The two leak free test plates are currently accumulating additional exposure time. A new fluorocarbon type elastomer coded XA-5407 by 3M is under test for a fuel fillet sealant.

#### Exterior Paint

Five top ranked exterior paint candidates (determined by screening studies) are being subjected to final qualification tests. Painted panels will be exposed four months (equivalent to about one year of SST service) in a test facility now being constructed. The test facility will simulate the cyclic variations of temperature, pressure, and ultraviolet radiation encountered during SST flight. Panels will be subjected to extensive tests of paint properties at the completion of the exposure period.

Eight additional exterior paint candidates have been given a screening evaluation. Painted panels representing each candidate were subjected to (1) heat aging under 430°F, 30 torr conditions for 168 hours and (2) water immersion for 168 hours to simulate extreme conditions expected in SST service. Paint properties evaluated were:

- Bend adhesion
- Emittance
- Emittance change after heat aging
- Change in appearance after heat aging
- Change in appearance after water immersion
- Pencil hardness at 430 - 450°F
- Change in pencil hardness at 430 - 450°F

D6-18110-5

### III. Description of Technical Progress (continued)

#### 1008. Materials and Processes (continued)

None of the eight candidates demonstrated marked improvement in paint properties over the 23 candidates screened initially. One of the new candidates is a clear silicone. This material exhibited an emittance 25 percent lower than the average emittance of pigmented materials, thus substantiating the predicted need for pigmented films.

#### Heat Treat Protective Coatings for Titanium

Several additional heat treat protective coatings have been compared with the coatings currently used (Turco Pretreat and Everlube T-50).

The coatings were evaluated at temperatures of 1000, 1250, 1725, and 1900°F. The results were as follows:

<u>Material</u>		<u>Effectiveness of Scale Prevention and Ease of Scale Removal</u>
Pretreat	(Turco)	Looks good even at 1900°F
T-50	(Everlube)	Looks good even at 1900°F
RA-536	(Glidden)	Looks good even at 1900°F
RA-537	(Glidden)	Good, but not at 1900°F
RA-538	(Glidden)	Not acceptable
A 498	(Glidden)	Not acceptable
HD 205	(Kerns)	Not acceptable
Covington	(deTimet)	Not acceptable

The coatings that appear acceptable in the screening tests will be subjected to a thorough testing program. This testing will include metallographic examination and gas analysis for oxygen penetration.

#### Materials Compatibility Studies

Deflection screening tests performed on two sealants, Dow Corning 94-002 and General Electric RTV-106, indicated a slight embrittlement of the titanium alloys. Fatigue tests and environmental crack propagation tests will be performed to quantitatively determine the extent of this surface effect. The effect is apparently due to acetic acid released as a by-product of the sealant cure mechanism. Dow Corning 94-002 was selected for further testing because, being more impervious to the acetic acid than General Electric RTV-106, it concentrates more corrosive liquid on the metal-sealant interface. Tension fatigue specimens, fabricated from Ti-6Al-4V sheet stock, are to be coated with 94-002 and elastically stressed for extended periods of time at room temperature and 450°F prior to fatigue testing. Fatigue cracked Charpy specimens fabricated from Ti-6Al-4V and Ti-8Al-1Mo-1V are to be coated with 94-002 sealant and cured until the acetic acid rich liquid concentrates in the crack. The stress intensity factor (Kc) at which rapid crack extension occurs will then be determined.

### III. Description of Technical Progress (continued)

#### 1008. Materials and Processes (continued)

##### Compatibility of Manufacturing and Materials

Testing has continued to establish compatibility with titanium alloys of additional materials proposed for manufacturing use. Tests for stress corrosion cracking of titanium alloys (4Al-3Mo-1V, 6Al-4V, and 8Al-1Mo-1V) were performed using a glass "kettle" with a vented lid. Titanium alloy specimens were bent and restrained in the form of a U (100% yield stress) and placed in the kettle. The assembly was then placed in a preheated oven. The specimens were then examined for evidence of cracking.

The following materials were tested with the following results:

Conditions	450°F, 16 Hrs. Material	Titanium Alloy		
		6Al-4V	8Al-1Mo-1V	4Al-3Mo-1V
	NH <sub>3</sub>	OK	OK	OK
	XF 1-0294 (Hydraulic Fluid)	OK	OK	OK
	ZL-2 Penetrant Fluid	OK	OK	OK
	ZL-22 Penetrant Fluid	OK	OK	OK
	ZE-4 Penetrant Emulsifier	OK	(Slight evidence of etching) OK	OK
	Dy-Chek Penetrant	OK	OK	OK
	Dy-Chek Developer	OK	OK	OK
	Dy-Chek Emulsifer	OK	OK	OK
	Rapid Tap Tapping Fluid	OK	Cracked	--
	Methyl Chloroform	Cracked	Cracked	--
	Habcool 318	Cracked	Cracked	OK
	175-K-14 (Fuller) Temp. Protect. Coating	Cracked	Cracked	OK

##### Evaluation of Extreme Temperature (ET) Greases for Use in Supersonic Aircraft

Twenty-four greases submitted by grease manufacturers and recommended for high temperature service were evaluated for load carrying capacity at 400°F. A four ball wear and friction test machine was employed for all tests with loads of 4, 10 and 50 kg. A scar diameter in excess of 1.00 mm on the 440C stainless steel test balls after testing is considered to be excessive.

Wear and friction data is presented in Table B for the three most promising greases. Further evaluation of these materials will be conducted in actual bearing tests.

##### Solid Film Lubricant Evaluations for Journal Bearing Applications

Fifteen commercially available solid film lubricants have been evaluated for wear life under the following conditions:

D6-18110-5

**Table B. High Temperature Grease Evaluation**

Test Conditions:

Speed: 600 RPM  
 Temperature: 400°F  
 Duration: 1 Hour  
 Ball Material: 440C Stainless Steel

Grease	Scar Dia., mm at 4kg Load	Friction Coefficient	Scar Dia., mm at 10kg Load	Friction Coefficient	Scar Dia., mm at 50kg Load	Friction Coefficient
Dow Corning E-4-3025	0.21	0.05-0.08	0.57	0.08-0.3	0.59	0.08-0.18
duPont 240AB	0.31	0.10-0.15	0.31	0.10-0.13	0.66	0.10-0.13
Marlin Rockwell Corp. EG 551	0.21	0.05-0.08	0.25	0.05-0.08	0.42	0.05-0.08

### III. Description of Technical Progress (continued)

#### 1008. Materials and Processes (continued)

- (1) Materials - 440C stainless steel rubbing against 17-7PH steel
- (2) Load - 10,000 psi
- (3) Temperature - 450°F
- (4) Speed - 5.67 ft/min
- (5) Motion - reciprocating at 34 cpm and 1.0 inch stroke

Four runs were made with each coating and a total of 59 tests were conducted. The best solid film lubricant found among those tested was an inorganic glass bonded MoS<sub>2</sub>-graphite-silver composition designated by the trade name, "Vitrolube," and supplied by National Process Industries. The average wear life of this coating was 83,027 cycles (13,900 feet total travel). This wear life is at least 4 times longer than other lubricant coatings tested and indicates that Vitrolube is one of the best solid film lubricant coatings commercially available today for use at temperatures up to 450°F.

The average wear life of each solid film lubricant tested is given in Table C.

#### Evaluation of Self Lubricating Movable Seal and Rub Strip Materials

Friction and wear tests on the Boeing lubricant compact material Number 108, consisting of MoS<sub>2</sub> and tantalum sintered under high pressures demonstrate that this material will meet the movable seal application requirements of the SST engine inlet centerbody. The test conditions and specimen configuration simulating engine inlet centerbody application were as follows:

First	1,200,000 cycles or 40,000 ft of travel: Load - 15 lb normal to rubbing surface Temp. - 535°F Motion - reciprocating at 29 cpm and 0.20 inch stroke
Final	200,000 cycles or 6,700 ft of travel: Load - 25 lb normal to rubbing surface Temp. - 600°F Speed and motion - same as above

The contacting surface of the lubricant compact was machined to a 0.5 inch radius prior to test and wear was measured as the distance between the crown on the radiused surface and the back side of the compacts. The coefficient of friction did not exceed 0.25 (0.50 allowed)

Table C. Average Wear Lives of Commercially Available Solid Film Lubricants  
at 450°F and 10,000 PSI Load Conditions

Lubricant	Vendor	Binder Type	Lubricant Pigments	Life Cycles Average Wear
Vitrolube	National Process Ind.	Inorganic Glass	MoS <sub>2</sub> , Graphite, Silver	83,027
Modified Vitrolube	National Process Ind.	Inorganic Glass	MoS <sub>2</sub> , Graphite, Gold	50,475
Everlube 811	Everlube Corp.	Sodium Silicate	MoS <sub>2</sub> and others	18,891
Ecoalube	Everlube Corp.	Silicone Resin	MoS <sub>2</sub> and others	15,999
Fel-Pro C-300	Fel-Pro, Inc.	Silicone Resin	MoS <sub>2</sub> , Graphite, Lead Oxide	11,787
NPI-14	National Process Ind.	Organic Resin	MoS <sub>2</sub> , Graphite	6,852
MRC DF 700	Marlin Rockwell Corp.	Sodium Silicate	MoS <sub>2</sub> , Graphite	6,629
Everlube 620	Everlube Corp.	Organic Resin	MoS <sub>2</sub> , Graphite	5,226
Electrofilm 77S	Precision Engr.	Organic Resin	MoS <sub>2</sub> and others	3,410
Electrofilm 4396	Precision Engr.	Organic Resin	MoS <sub>2</sub> , Graphite	2,216
Spraymix #1A	Industrial Plating	Organic Resin	MoS <sub>2</sub> , Graphite	2,369
Electrofilm 4856	Precision Engr.	Organic Resin	Graphite and Metals	1,006
Electrofilm 4253	Precision Engr.	Resin	Graphite, Indium, Silver	687
Electrolize	Electrolize, Inc.	Electric Deposit	Dense Chromium Plate	72
Microseal 100-1	Microseal Corp.	Impingement Process	Graphite	1

### III. Description of Technical Progress (continued)

#### 1008. Materials and Processes (continued)

throughout the test, and total wear of the Boeing compact No. 108 was 0.011 (0.30 allowed) inches after traveling a total distance of 46,700 feet under the conditions outlined above.

Friction and wear evaluation of other self lubricating rub strip materials made from carbon, PTFE, MoS<sub>2</sub>, and others is continuing.

#### Evaluation of High Temperature Inorganic Lubricants

Improvements in lubricant application techniques through use of special pretreatments, flame spray, and plasma spray methods are being investigated. Adequate adhesion has been obtained between a MoS<sub>2</sub>-PTFE lubricant and 6Al-4V titanium alloy specimens pretreated with an aluminum based protective coating per EMS 14-4. The friction and wear properties of this coating are being measured. Coatings to be evaluated are listed in the following table:

<u>Coating</u>	<u>Manufacturer</u>	<u>Remarks</u>
MoS <sub>2</sub>	Teleflex Inc.	Phosphate Binder
MoS <sub>2</sub>	Plasmadyne	Plasma Spray
Ni coated MoS <sub>2</sub>	Plasmadyne	Plasma Spray
Ni coated graphite	Cerac	Plasma Spray

#### Development of Anti-Galling Coatings for Titanium Under Light Loads

Evaluation is continuing of anti-galling coatings to protect titanium from galling when rubbing against itself under light loads at 450°F. Five different coatings were applied to 6Al-4V titanium alloy and tested under conditions of 200 psi load, and a reciprocating sliding speed of 4 ft/min. and 60 cpm.

Wear life of these coatings ranged from 1,200 cycles or 79 feet total travel (Watervliet Hardcoat) to 13,000 cycles or 860 feet total travel (Lubeco 2123). A general description of the anti-galling coatings and their respective wear life is given in Table D.

#### Elevated Temperature Resistant Laminates

Skybond 700 - Butanol solvent system shows no significant improvement over Skybond 700 - High Polar solvent system. The Skybond 700 - Butanol solvent system also has a shorter shelf life. Therefore, further development work will be concentrated on the High Polar solvent system.

Amoco AI-11 offers no advantages with a Butanol solvent system, more development work using a different solvent system is contemplated.

Actual test data is summarized in Figs. 20, 21, and 22.

D6-18110-5

Table D. Wear Life of Anti-Galling Lubricant Coatings for Titanium

<u>Lubricant</u>	<u>Vendor</u>	<u>Binder Type</u>	<u>Lubricant Pigments</u>	<u>Wear Life</u> <u>Cycles</u>	<u>Feet</u>
Vitrolube	National Process Ind.	Inorganic Glass	MoS <sub>2</sub> , Ag Graphite	117,000	7,730
Bemol 120	Bemol, Inc.	Organic Resin	MoS <sub>2</sub> , Graphite	4,700	311
Spraymix #1A	Industrial Plating	Organic Resin	MoS <sub>2</sub> , Graphite	6,500	429
Electrofilm 4396	Precision Engr.	Organic Resin	MoS <sub>2</sub> , Graphite	5,100	336
Lubeco 2123	Lubeco, Inc.	Inorganic Phosphate	MoS <sub>2</sub> , PbS, Graphite	13,000	860
Watervliet Hardcoat	Watervliet Arsenal	Anodize	---	1,200	79

DC-18110-5

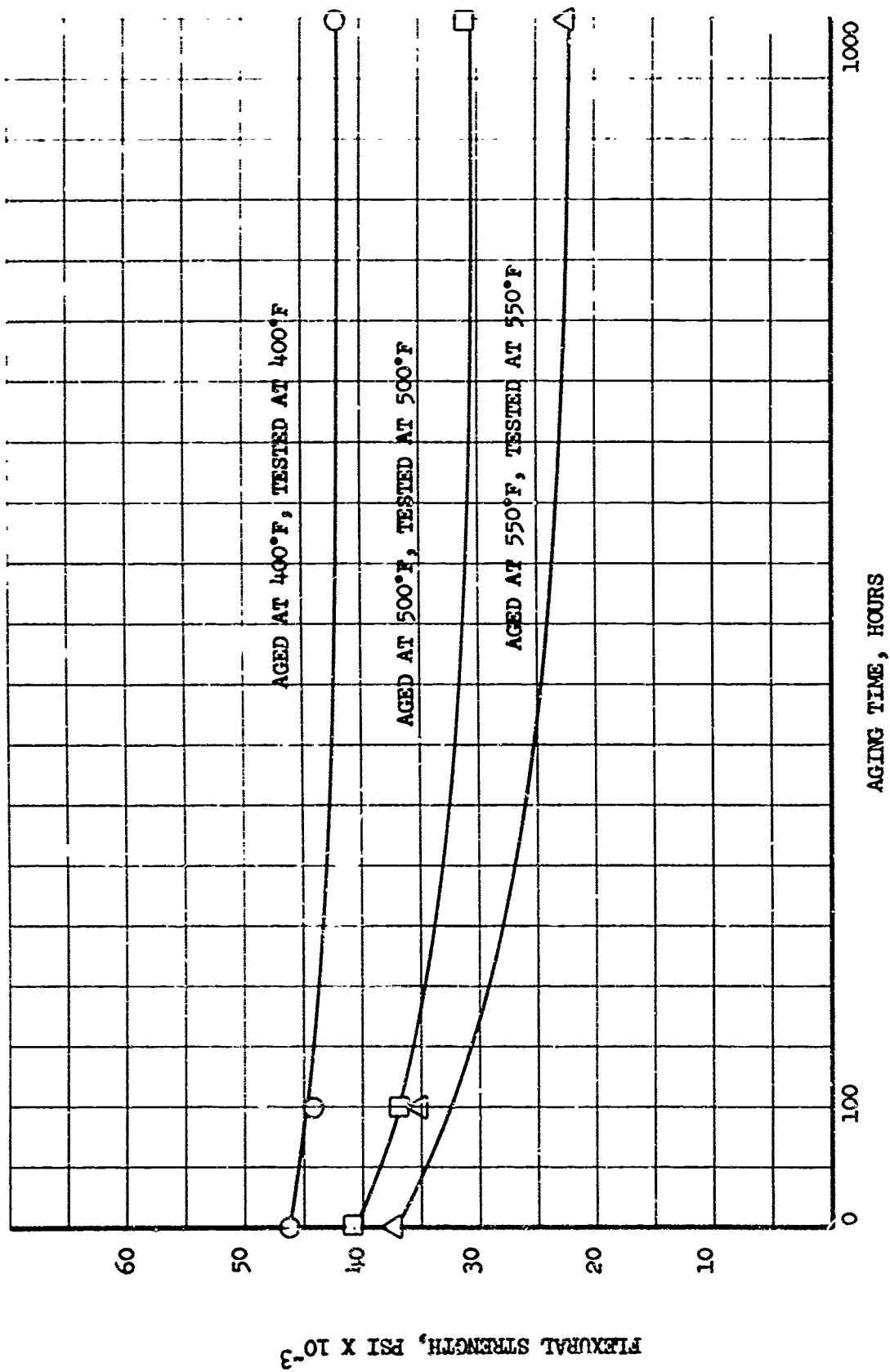


Figure 20. Flexural Strength, Skybond 700-High Pol.r Solvent

D6-18116-5

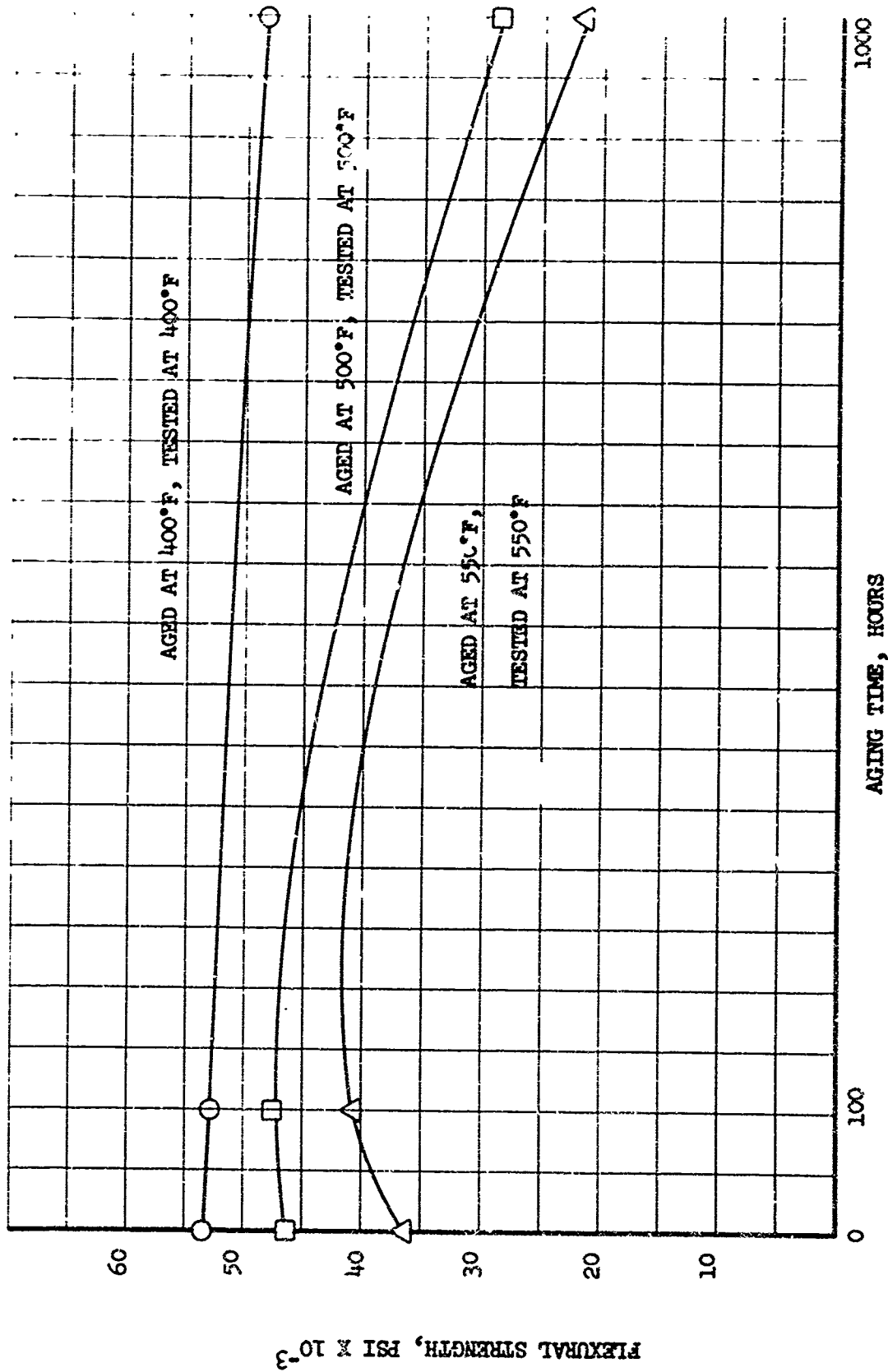


Figure 21. Flexural Strength, Skybond 700-Butanol Solvent

D6-18110-5

D6-18110-5

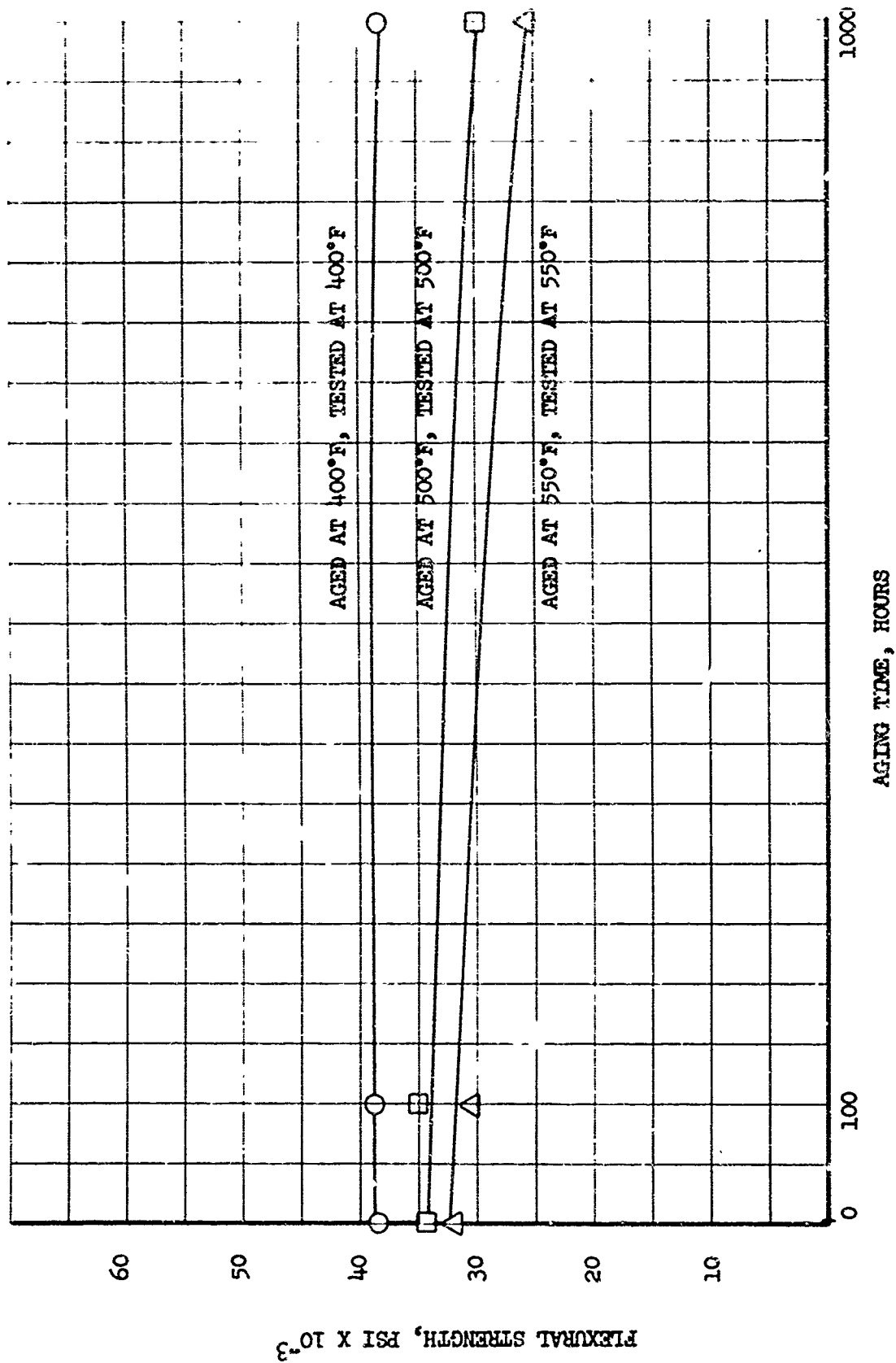


Figure 22. Flexural Strength, Amoco Al-11

### Wing Pivot Two-Inch Bearing Program

Materials evaluation for the wing pivot bearings and similar applications is continuing. The effects of heat, contaminants, and manufacturing process variables on bearing life are currently being evaluated. Adhesives other than Epon 957 are also being evaluated for comparison and life improvement purposes.

The following tests have been completed since the March 1966 report:

SPECIMEN NUMBER	TEST CONDITIONS		SOAK FLUID USED PRIOR TO TEST	SOAK CONDITIONS	ADHESIVE USED	BOND-LINE THICKNESS (mils)	WEAR LIFE	
	LOAD ksi	TEMP. °F					CYCLES	FEET
292	20	300	heat only	100 hrs @ 300°F	Epon 957	16.3	510,735	100,000
267	3		none	---	Epon 957	13.5	413,175	81,600
268	3		none	---	Epon 957	12.6	89,625	17,700
291B			EPO 5251	10 days @ 300°F	Epon 957	16.0	1,072,989	197,400
275			Delco E-Z Strip	4	Epon 957	14.7	343,072	60,500
284			Jet Fuel JP-5	10 days @ 200°F	Epon 957	14.1	328,100	58,300
283B			XP 1-0294	10 days @ 300°F	Epon 957	13.7	236,389	43,100
274B			XP 1-0294	10 days @ 200°F	Epon 957	14.0	220,394	42,400
272			MIL-C-15074 Anti-icing	10 days @ 200°F	Epon 957	14.3	567	101
269	3		none	---	Reichold A5900	12.5	203,292	36,400
270	3		none	---	Reichold A5900	10.0	98,164	17,600
290			none	---	FXM-34B-34 Polyimide	13.3	101,476	20,000
289			none	---	FXM-34B-34 Polyimide	13.3	76,342	15,100
280			none	---	FXM-34B-25A Polyimide	13.2	252	45
279	20	300	none	---	FXM-34B-25A Polyimide	13.3	78	14

- 1 Specimens with "B" suffix are same bearings without "B" but were rotated 180° prior to test. Bearings without "B" were reported on in the March report.
- 2 Failure occurs when shaft wears through fabric-adhesive liner to the metal ring.
- 3 Manufactured by Transport Dynamics, Inc., Santa Ana, Calif.
- 4 Soaked for 22 hours at room temperature then dried for 2 hours at 300°F. Cycles repeated 10 times.

### III. Description of Technical Progress (continued)

#### 1008. Materials and Processes (continued)

##### High Temperature Resistant Reinforced Plastic Honeycomb Core

Significant improvement in quality and mechanical strength of reinforced polyimide honeycomb core has been achieved by the supplier (Hexcel Products Inc.) in recent months. Bias weave polyimide core, designated HRH-327, demonstrates properties far superior to previous developmental core materials of this type.

Mechanical properties of the original polyimide core received for the SST program have been determined after 5,000 hours aging at 400, 500 and 550°F. These values have been used to predict the mechanical properties of more recently developed HRH-324 (standard weave polyimide) core after 5,000 hours thermal aging. Testing following aging at 450°F has been completed at 100 hours on HRH-327 and 1,000 hours on HRH-324.

Thermal stability studies of the polyimide seal coat used to eliminate polyimide core porosity are being conducted.

Figures 23 and 24 compare the "L" direction shear strength and modulus of HRH-324 and HRH-327 core. Testing was conducted at the temperature of thermal aging.

##### Heat Resistant Foams

Three additional candidate polyurethane foams (one formulated in Boeing's laboratory and the other two procured from the Upjohn Co.) have been heat aged for an extended period of 500 hours at 350 and 375°F and the weight loss and dimensional change determined. Results are summarized and graphically presented in Fig. 25. Although no significant difference in weight loss was observed between the Boeing formulated foam (MRH-20) and the two Upjohn foams (CPR21-10 and CPR23-10) at 350°F, a marked difference can be seen at 375°F. In addition, severe distortion was observed on the two commercial foams after 100 hours at 375°F. Foam formulations (B) and (2), two of the more thermally stable foams previously tested and reported in March Bi-Monthly FAA Progress Report, are included in this report for comparison.

Fuel resistance of CPR21-10 and 23-10 was determined after immersion in JP-5 for 100 hours at ambient room temperature. Foam specimens showed no dimensional change after fuel immersion. However, a weight increase of 33.7 percent and 39.0 percent for CPR21-10 and CPR 23-10 was obtained. Presently, the Boeing formulated foam specimens are undergoing fuel soaking-thermal aging cycling tests.

##### Adhesives

Heat stability studies of XBMS 5-53 adhesive are continuing. 500°F exposure in air at atmospheric pressure has passed the 6,000 hour mark. The adhesive is maintaining lap shear strength of 2,000 psi when tested at 500°F. Recent supplier data shows retention of this strength

D6-18110-5

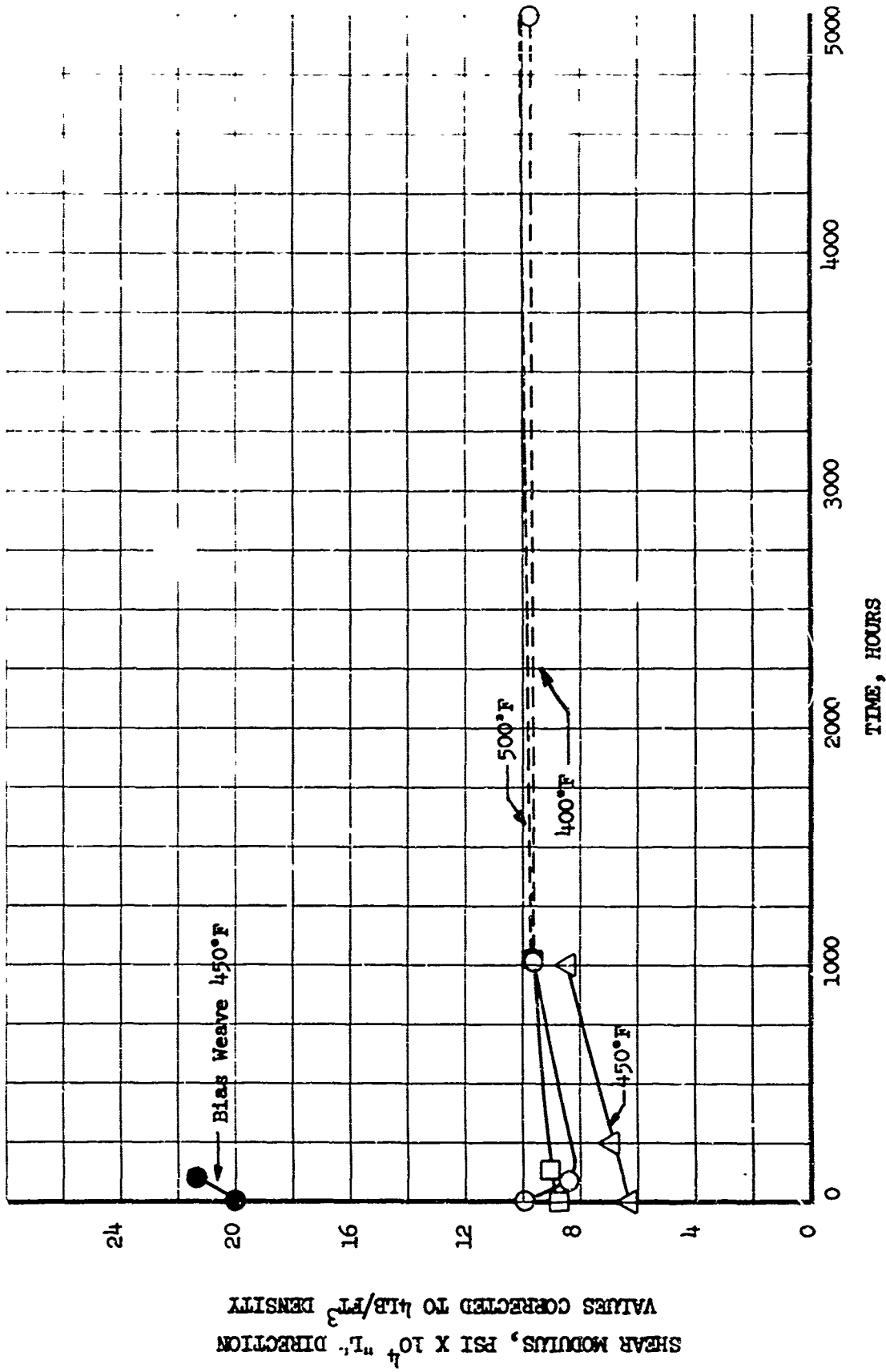


Figure 23. Shear Modulus of HRH-324 Polyimide Honeycomb Core

D6-18110-5

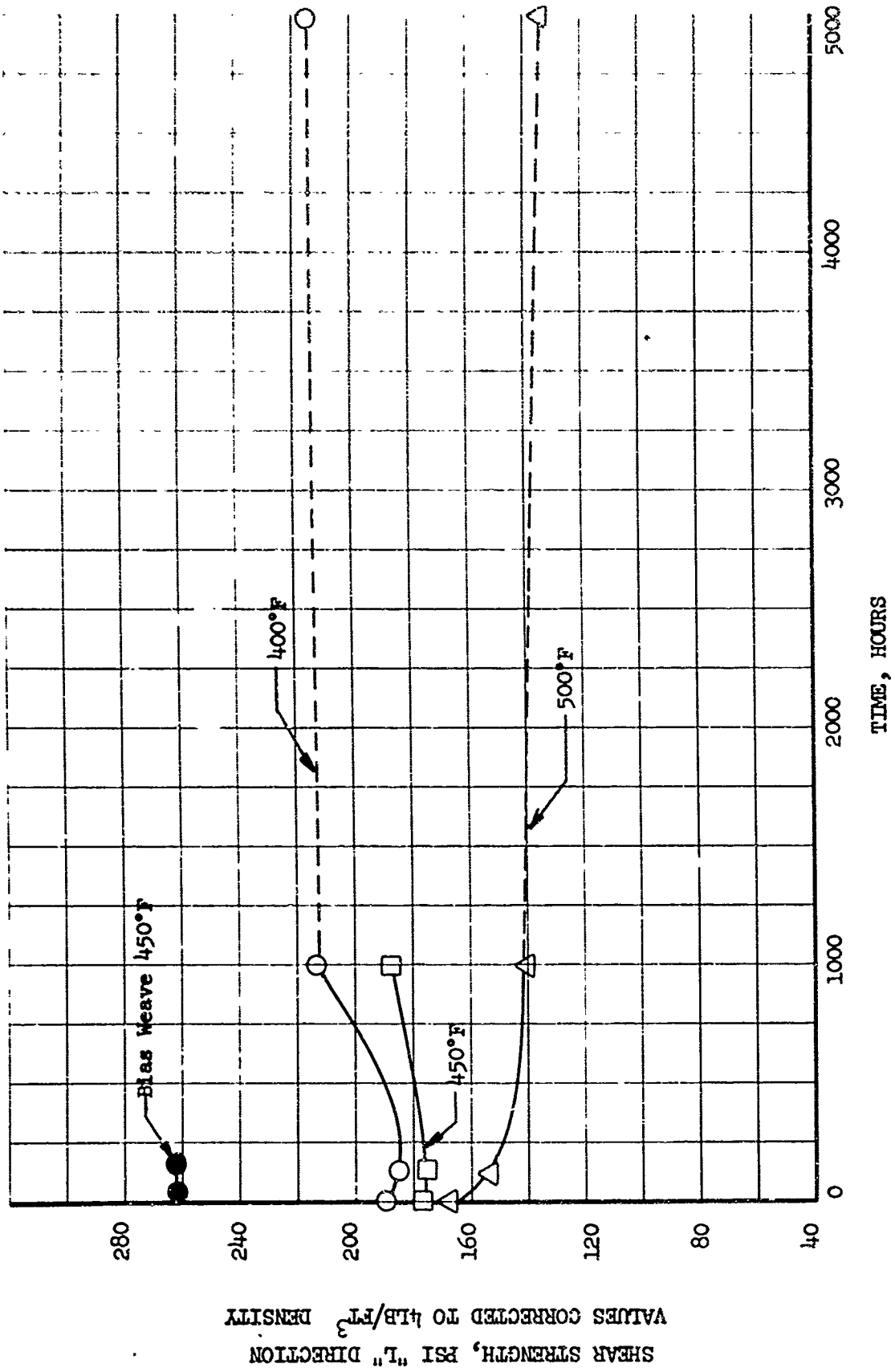


Figure 24. Shear Strength of HRH-24 Polyimide Honeycomb Core

D6-18110-5

NOTE: FORMULATION (B) & (2) PREVIOUSLY REPORTED IN MARCH PROGRESS REPORT

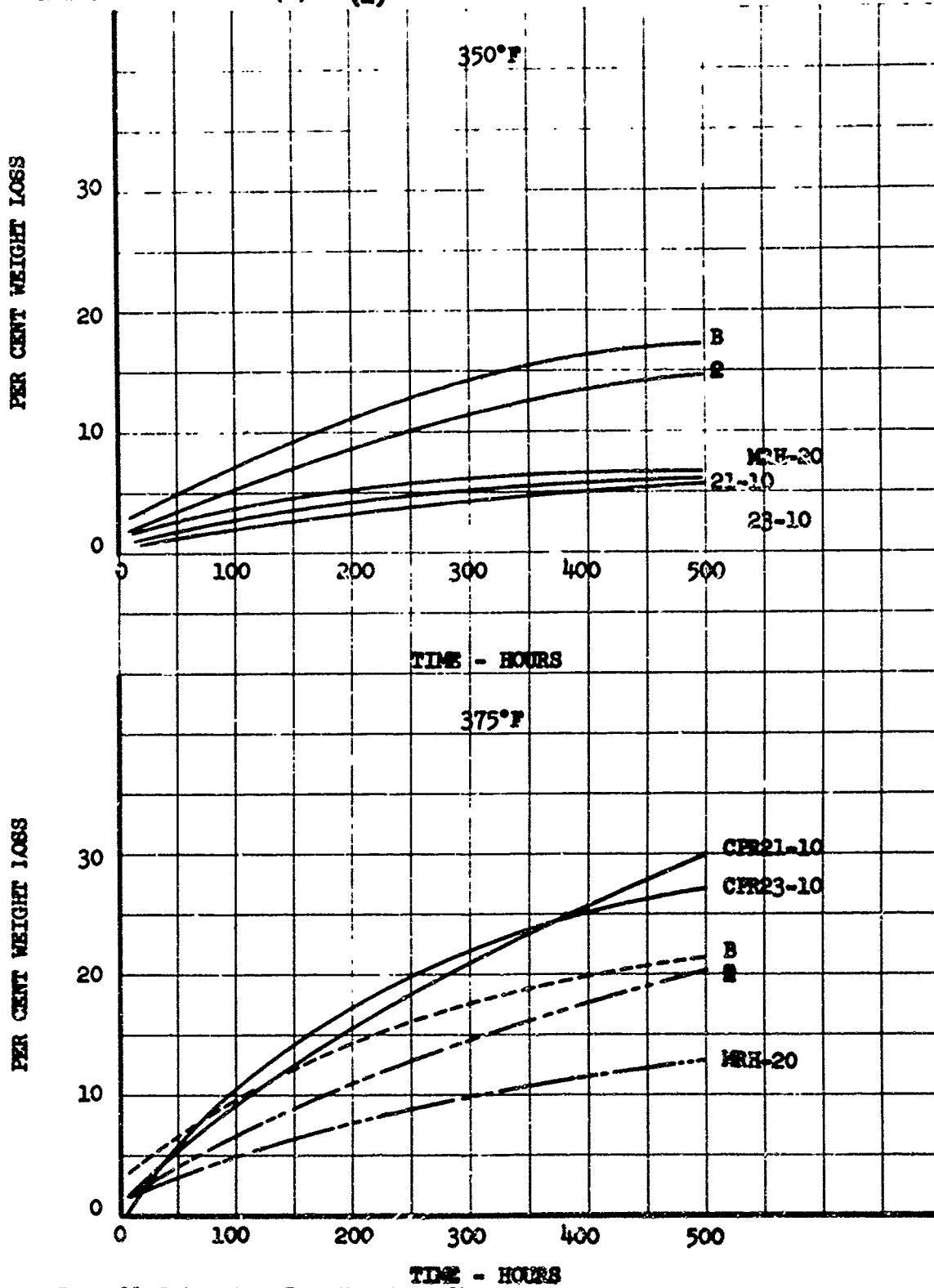


Figure 25. Polyurethane Foam Heat Aging Characteristics

D6-18110-5

### III. Description of Technical Progress (continued)

#### 1008. Materials and Processes (continued)

extends to 15,000 hours. Preliminary data from process improvement studies indicates that these values can be exceeded.

Recent process improvements in the fabrication of polyimide face, HRH-324 honeycomb core, titanium face sandwich panels have resulted in flatwise tensile strengths averaging 700 psi with no values below 600 psi. Twenty specimens were tested.

#### Residual Stress in Titanium Alloys

Fusion welded 0.500 inch thick Ti-8Al-1Mo-IV panels with approximately 70 ksi residual tensile stress were stress relieved using a high pressure pulse generated by an explosive charge. Figure 26 shows the residual stress distribution in the panels before and after stress relief. The flatness of the panels was improved by the stress relief process. Tensile properties of specimens machined from the stress relieved panels showed no significant change from those of the as-welded panels.

Dual gas-tungsten-arc welded 0.250 inch thick Ti-6Al-4V panels were stress relieved at various explosive pressure levels. Figure 27 shows a comparison of the residual stress level parallel to the weld before and after stress relief.

Hot roller planishing of fusion welds was effective in stress relieving the welds. The planishing process was effective when weld geometry was uniform, the weld was flush with the base metal, and the area planished was larger than the high stress region. Tensile and yield strengths of specimens from hot roller planished Ti-6Al-4V fusion welded panels were approximately the same as those from the as-welded specimens. However, the elongation was somewhat less.

The residual tensile stress measured in an electron beam weld in titanium was nearly 90 ksi.

The residual stresses were measured in Ti-6Al-4V joints fastened with A286 rivets with various heading forces. Figure 28 shows the correlation found between fatigue life at 40 ksi, heading force and residual compressive stress.

#### Mechanical Joint Fatigue Life Improvement

The effect of heading force of lap joint specimens fastened with Ti-6Al-4V rivets on fatigue life is indicated in Fig. 29. The fatigue life was found to increase with increase in heading force.

A study of the effect of hole size on lap joint fatigue life was conducted with Ti-6Al-4V specimens fastened with A286 and Ti-6Al-4V rivets. Figure 30 shows fatigue curves for A286 rivets installed in holes varying from 0.002 inch interference fit to 0.010 inch clearance.

D6-18110-5

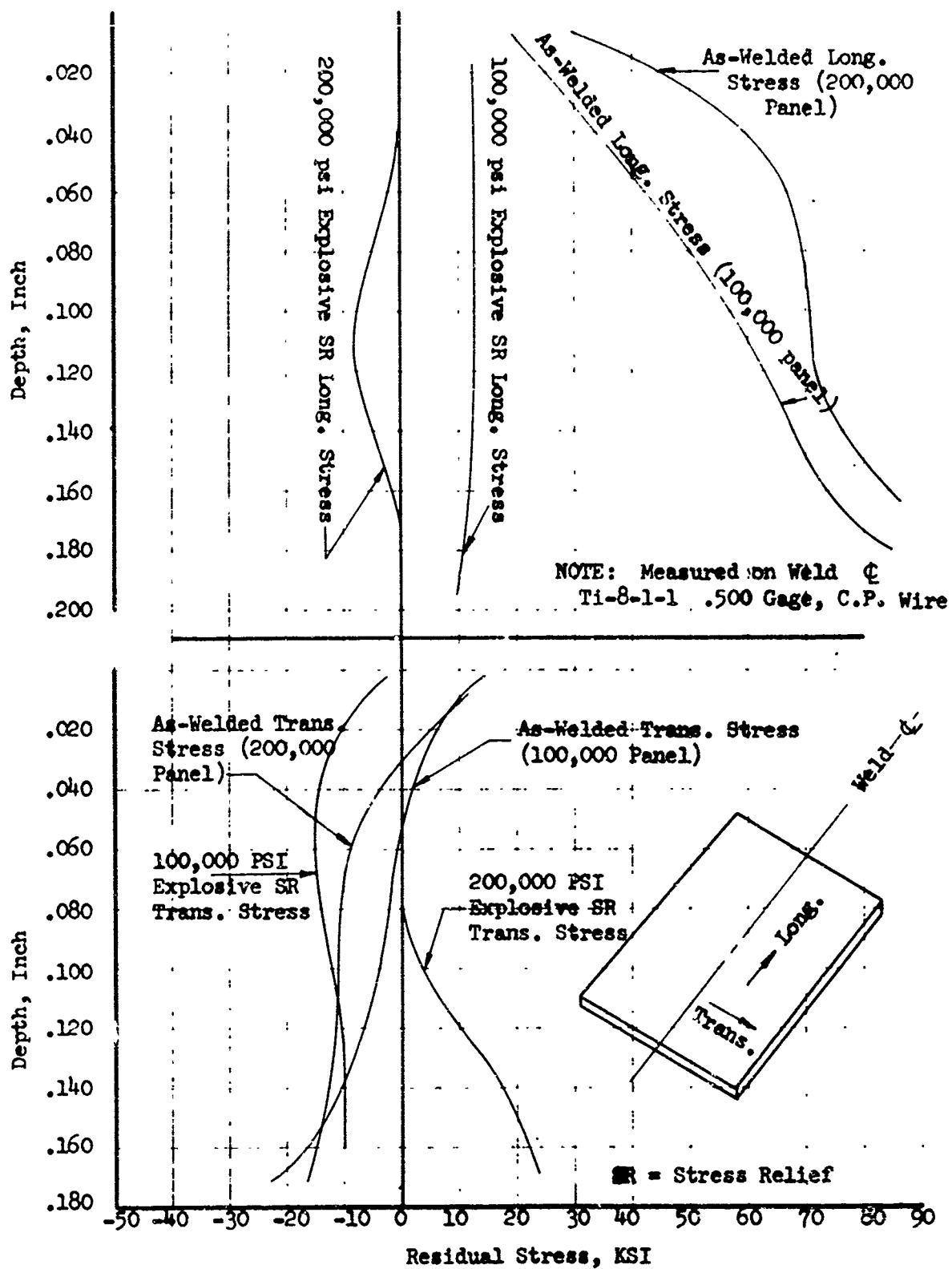


Figure 26. Effect of Explosive Stress Relief on Residual Stress in Welded Ti 8Al-1Mo-1V

D6-18110-5

MAXIMUM RESIDUAL STRESS, KSI

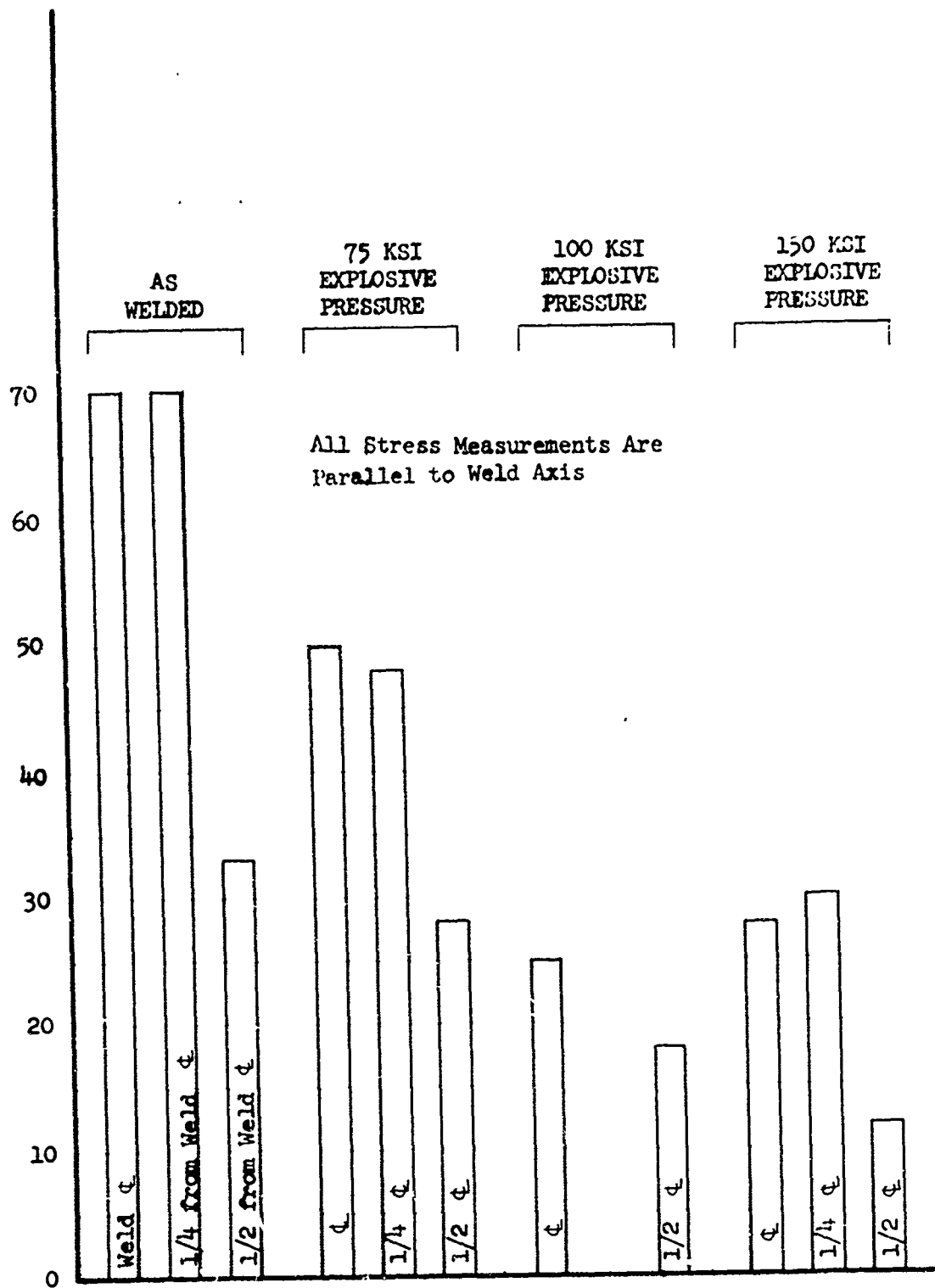


Figure 27. Effect of Explosive Stress Relief on Residual Stress in Welded Ti 6Al-4V

D6-18110-5

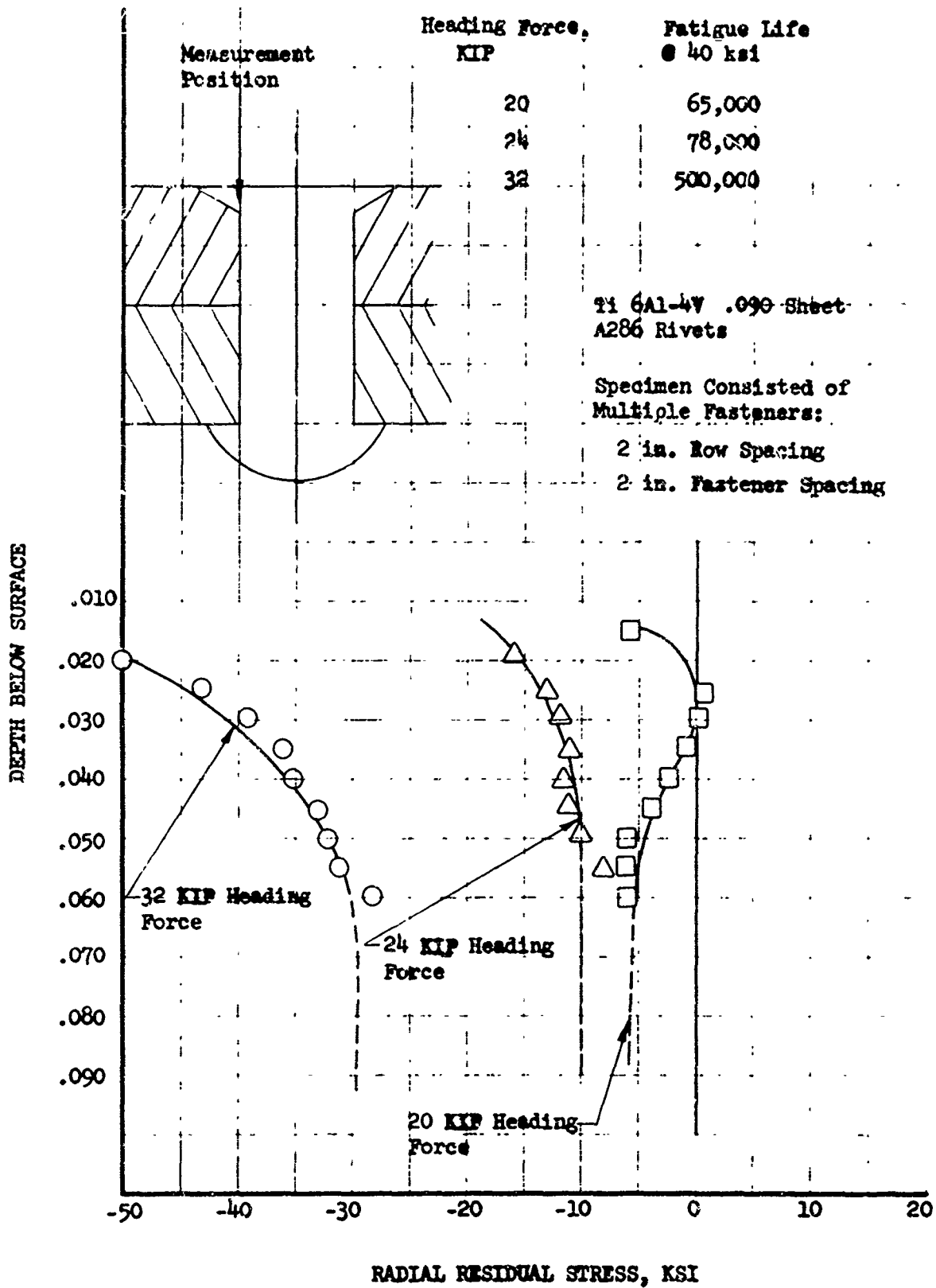


Figure 28. Effect of Residual Stress on Fatigue Life of Riveted Ti 6Al-4V Sheet

Do-18110-5

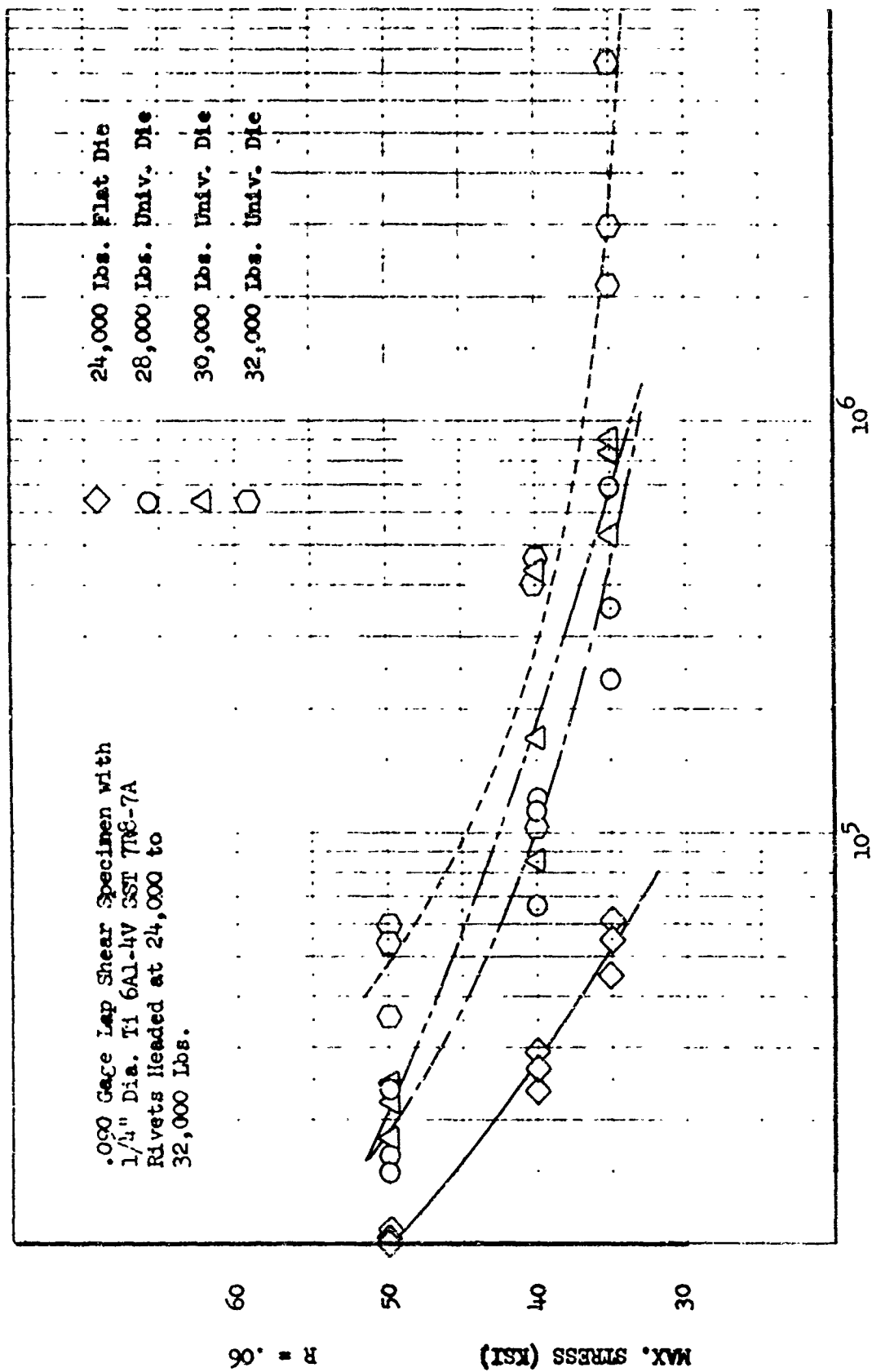


Figure 29. Heading Force Study for Ti 6Al-4V Rivets

.090 Gage Lap Shear Specimen  
 with 1/4" Dia. Ti 6Al-4V SST 7R8-7A  
 Rivets Headed at 32,000 lbs. with a  
 Universal Head Die

.001-.002 Interference  
 .002 Clearance  
 .006 Clearance  
 .010 Clearance

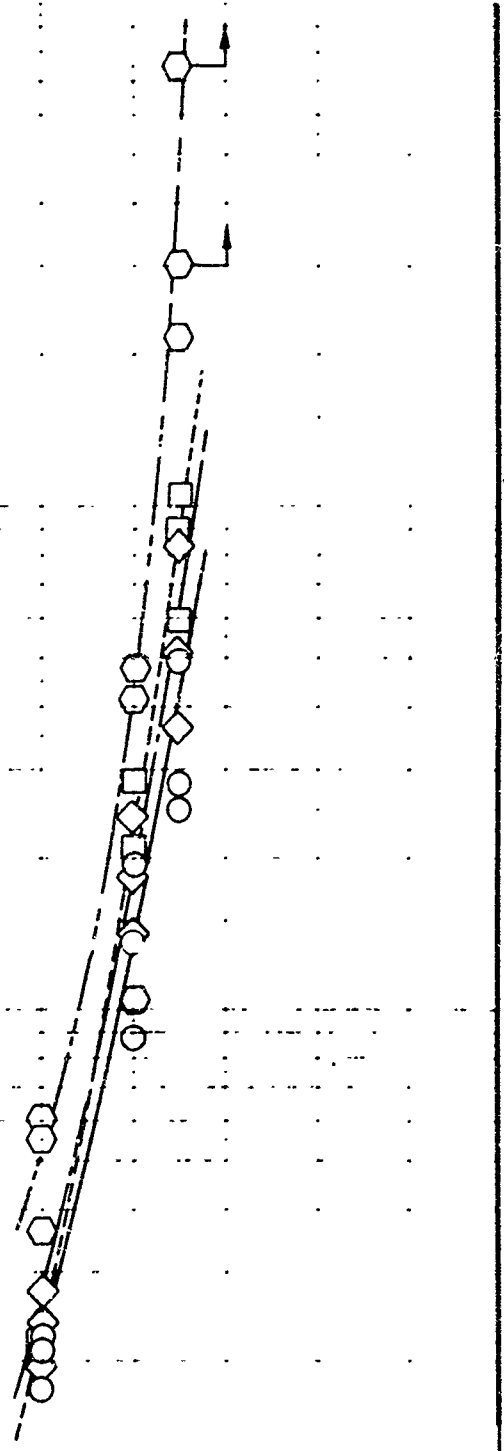
□  
 ○  
 ◇  
 ○

R = .06

MAX. STRESS (KSI)

60  
 40  
 20

D6-18110-5



10<sup>5</sup> 10<sup>6</sup>

CYCLES OF FATIGUE LOADING

Figure 30. Cycles of Fatigue Loading Hole Size Study for A286 Rivets

### III. Description of Technical Progress (continued)

#### 1008. Materials and Processes (continued)

Figure 31 shows similar data for Ti-6Al-4V rivets. The increase in the spread of the data for Ti-6Al-4V rivets is believed to be caused by heading force insufficient to produce the compressive stress needed for the larger holes.

Lap joints fastened with gun driven 0.250 inch diameter A286 rivets headed to 0.40 and 0.45 inch head diameter were evaluated. Figure 32 compares the fatigue life of these joints with compression headed rivets at 32,000 pounds. The gun driven rivets show a lower fatigue life than the compression headed rivets.

Additional installation procedures and tools will be investigated to improve the fatigue life of the gun driven rivets. Strain gages will also be used to measure residual stresses produced by rivet installation.

#### Effect of Testing Temperature on Riveted Joint Fatigue Life

Fatigue tests were performed at room temperature and at elevated temperature on Ti-6Al-4V sheet joined with A286 and Ti-13V-11Cr-3Al rivets. The results shown by Fig. 33 indicate a substantial reduction of fatigue life at 500°F. Since low squeezing pressures (24,000 pounds) were used on these specimens, additional specimens with rivets squeezed to 32,000 pounds will also be evaluated.

#### Interstitial Effects

Fracture toughness and environmental crack growth resistance in air were determined on beta rolled and STA-1250 treated Ti-6Al-4V 0.500 inch plate with various hydrogen and oxygen contents. Oxygen was introduced during melting while hydrogen was introduced into specimens after heat treatment by a Sieverts Apparatus. The results indicate that increasing hydrogen level to 175 ppm has little effect on crack growth resistance within a six hour test period. Preliminary data also indicates that there is no significant effect of 150 ppm hydrogen content on the crack growth resistance in air after a 600 hour test period.

The results also show that oxygen has a significant effect on toughness and crack growth resistance. The fracture toughness level drops from 95 ksi  $\sqrt{\text{in}}$  to about 35 ksi  $\sqrt{\text{in}}$  as the oxygen content increases from 1160 to 1870 ppm.

#### Fusion Welding

Slow bend precracked charpy impact tests were conducted on dual gas-tungsten-arc welded 0.250 inch thick Ti-6Al-4V. Figure 34 shows the fracture toughness ( $K_{Ic}$ ) in air and the environmental crack growth resistance ( $K_{Ii}$ ) in 3-1/2 percent NaCl solution of the weld, heat affected zone and base metal. The material at the weld centerline shows the highest toughness and crack growth resistance. The heat affected zone has less resistance to crack growth and the base metal shows the least resistance. Note: Ti-6Al-4V alloy will not be used

D6-18110-5

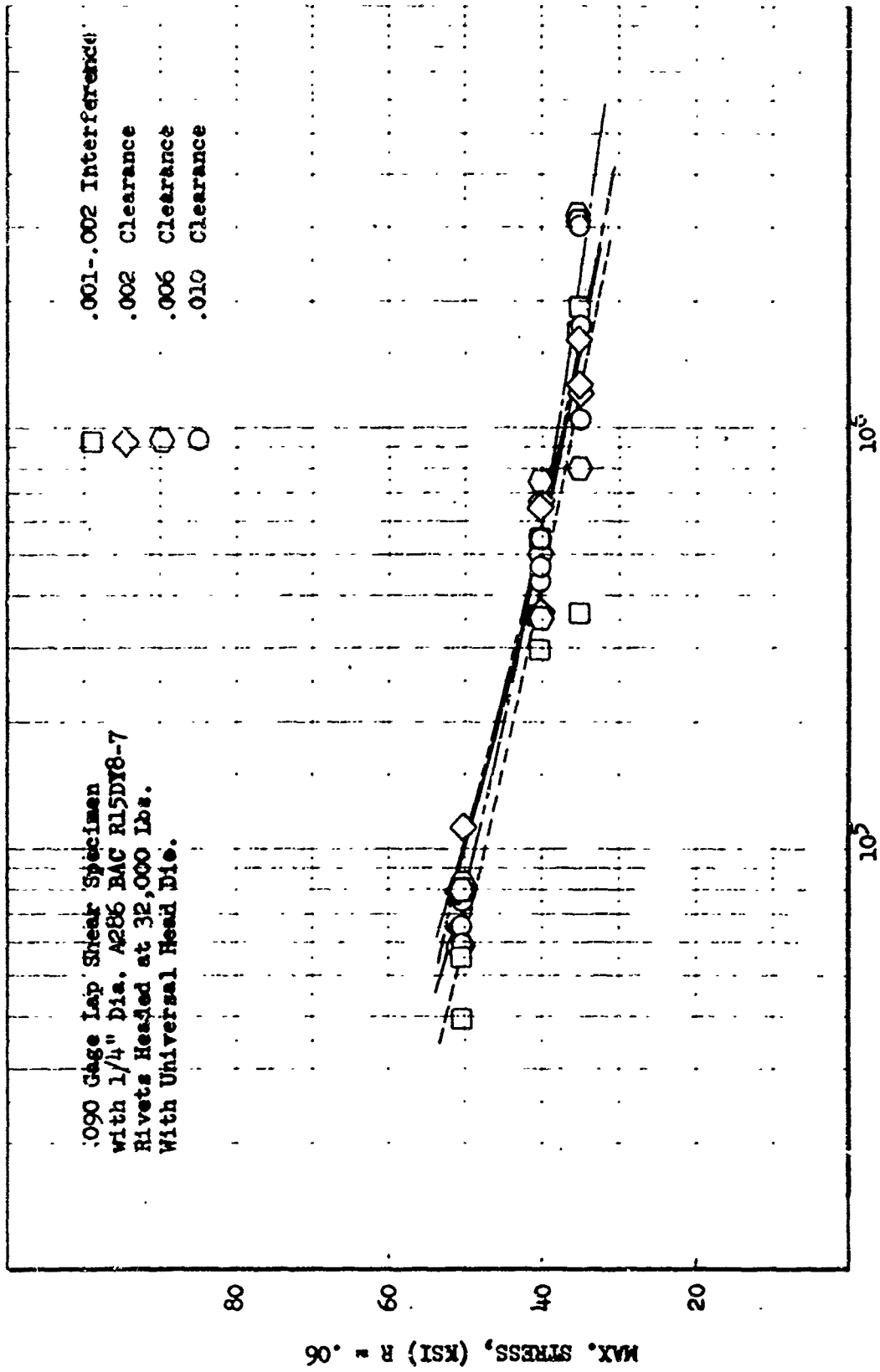


Figure 31. Hole Size Study for Ti 6Al-4V Rivets

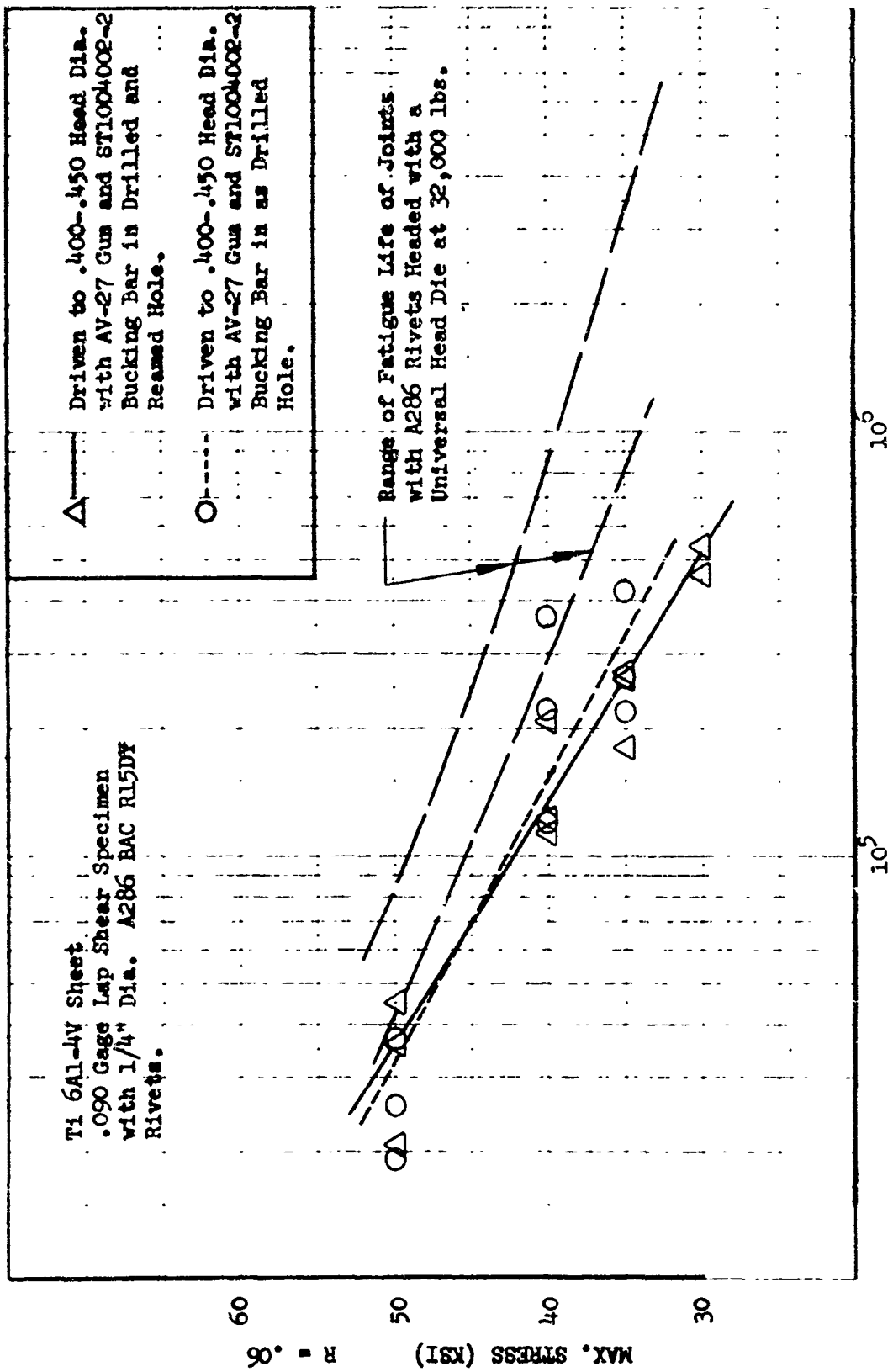
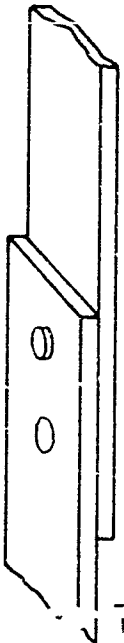
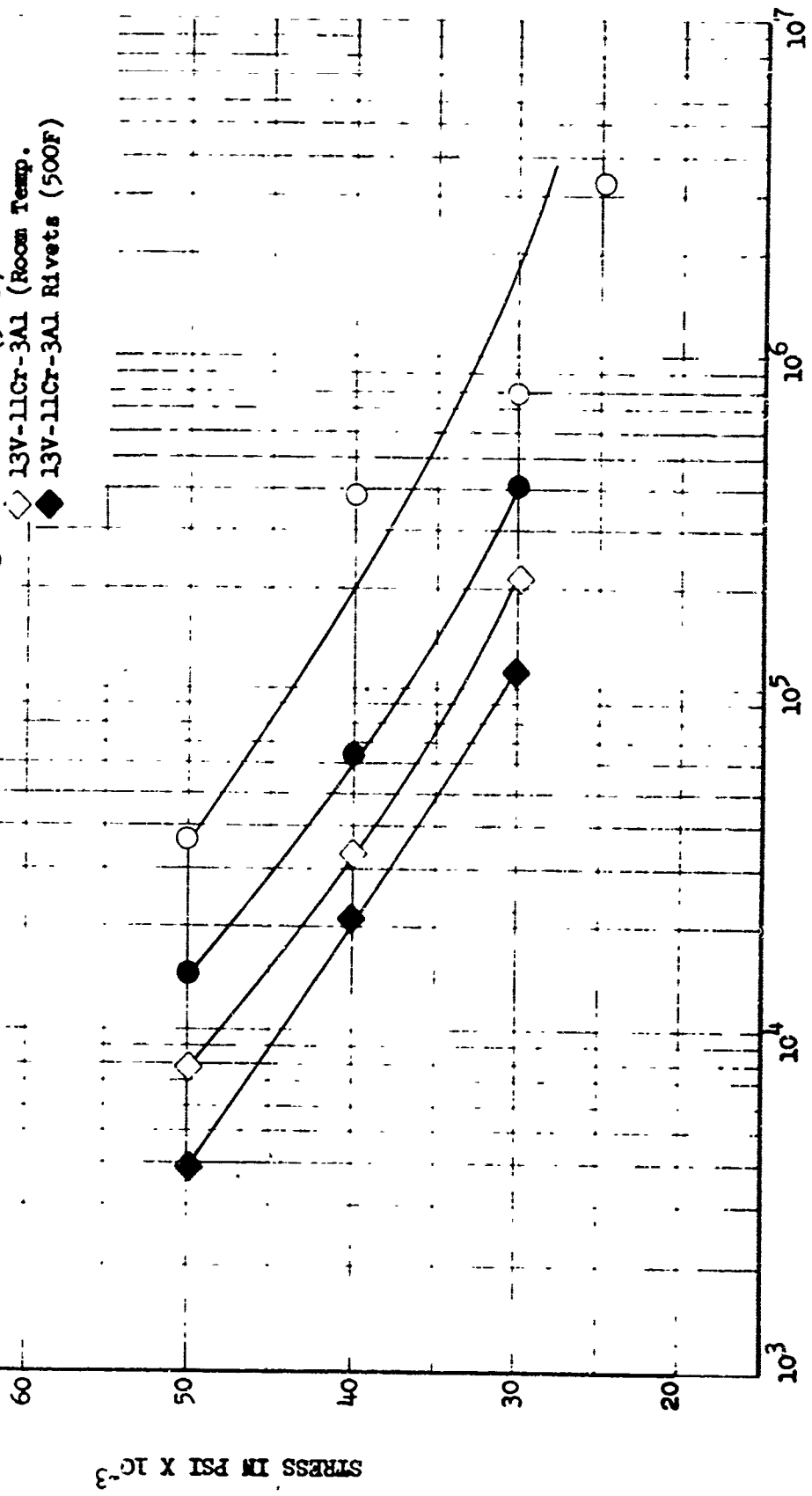


Figure 32. Cycles of Fatigue Loading Heading Study (Gun Versus Compression) for A286 Rivets

Rivets Squeezed to 24,000  
Lbs. with Flat Dies



- A286 Rivets (Room Temp.)
- A286 Rivets (500F)
- ◇ 13V-11Cr-3Al (Room Temp.)
- ◆ 13V-11Cr-3Al Rivets (500F)



CYCLES TO FAILURE

Figure 33. Effect of Temperature on Joining Fatigue Life

D6-18110-5

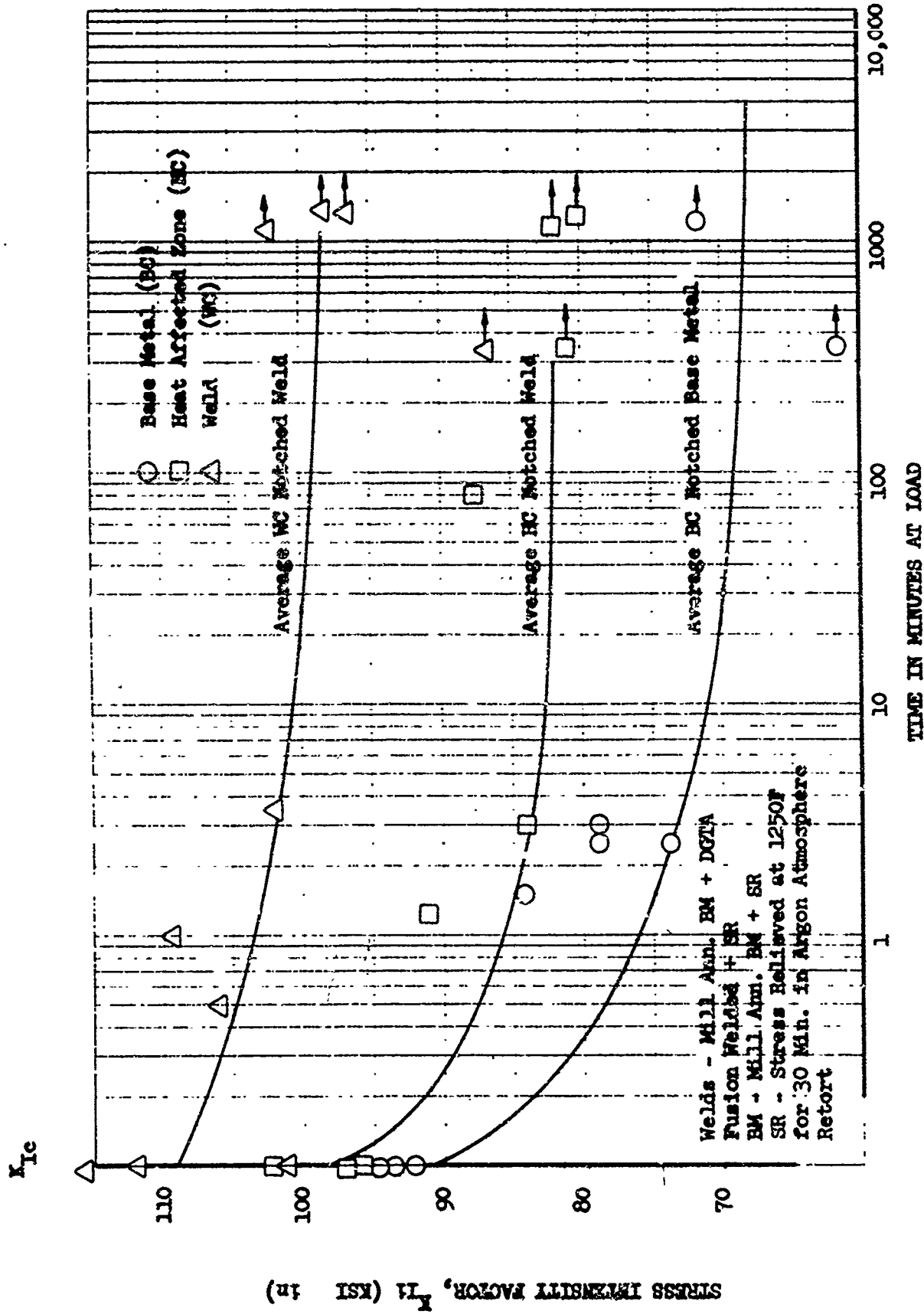


Figure 34. Sustained Loading Behavior in Salt Water of 0.250 In. Mill Annealed Ti 6Al-4V Weld

D6-16110-5

### III. Description of Technical Progress (continued)

#### 1008. Materials and Processes (continued)

in the mill annealed condition for 0.25 gage material. The weld data is valid.

#### 1009. Mockups

The Mockup Plan, Document D6A10008, is being revised to reflect changes in the Phase II-C program. The revised plan will be sent to the FAA early in June 1966.

Progress on the following mockup activities is reported in the applicable sections of this report, as follows:

<u>Mockup</u>	<u>Section</u>
Full-size inlet system	1302
Flight deck installations	1208
Preliminary electrical rack mounted components	1205
Preliminary electronic rack mounted components	1205
Cargo provisions	1213
Partial cabin interior	1213
Power plant	1300

#### 10092. DEMONSTRATION MOCKUPS

The Class I mockup and demonstration area plan has been approved and work has been initiated in all areas necessary to support program completion schedules.

The Class I mockup will be a complete full scale simulation of the proposal configuration. The outboard wings and the nose section will be movable. The landing gear will be fixed in the down position. The vehicle interior will include a finished passenger cabin with a full complement of seats.

The mockup and demonstration area will include other full scale mockups as follows:

- One P&W and one GE engine installation
- A lower baggage compartment which will demonstrate loading
- A complete flight deck
- A full size inlet
- A movable wing pivot showing systems routing
- An 8-foot wing section with movable surfaces.

As available space and time schedule permits, other mockup components will be included.

### III. Description of Technical Progress (continued)

#### 1010. Airframe Test General

Systems Test efforts during the past two months have been concentrated on the complete updating of the test and certification plan (detail work item 2070), a revision to the test management plan (detail work item 2130), and the accumulation of detail one-page test plans.

Approximately 2000 individual one-page test plans have been generated to date by technical personnel indicating the need for a laboratory, a ground, or a flight test. These plans are being reviewed for duplication and/or overlap and are being evaluated for possible omissions. The plans are forming the basis for the updating of the test and certification plan. Once evaluation and updating are completed, the test and certification plan and the one-page test plans will be used as guides in establishing cost baselines for the integrated test program.

#### 1012. Flight Test Program

Preliminary drafts of the following flight test documents have been prepared and are under in-house review. These documents will be used as support data for the test and certification plan:

- Engineering ground tests - describing all system testing to be accomplished from airplane rollout to first flight.
- Prototype development (flight) test plan - describing the flight testing and related ground testing to be accomplished on the two prototype airplanes after completion of the first 100 hours of flight testing.
- Precertification test plan - describing the flight testing considered necessary on the production airplanes to ensure that the airplanes are capable of meeting the FAA certification requirements for airworthiness.
- FAA certification demonstration plan - describing the flight test approach to obtaining airplane type certification.
- Production airplane acceptance test plan - covering the ground checkout and flight acceptance tests to be performed on each production airplane during company acceptance, FAA acceptance, and customer acceptance.
- Computing subsystem requirements - containing the requirements for the computing subsystem of the Flight Test Data System.
- Computer programs - defining the computer programs to be used during the Flight Test Program.

Preparations are under way for conducting a preliminary design review on the flight test data system airplane installation. The intent of the PDR is to uncover installation and design problems early enough so that they can be corrected before affecting production schedules of the airplanes. Data prepared for the presentation includes two-dimensional drawings of the flight test instrumentation system installation, the water ballast installation, the trailing bomb installation, and test wire routing information.

D6-18110-5

### III. Description of Technical Progress (continued)

#### 1013. Standardization

Mr. A. L. Paxhia has been appointed Standardization Manager of the Design Support Staff. Mr. Paxhia's experience within Boeing includes management of material and process staffs and divisional standards responsibility.

The Supersonic Transport Division operational manuals (policy, division directives, office instruction, administrative procedures, organization, and operating procedures) were completed. The manuals were published and distributed during May, as described by D6-17610, "SST Standardization Plan."

The SST Structural Allowables document was completed and distributed.

#### 1014. Quality Assurance

##### Test and Analysis

##### (1) Design Allowable Panels

Approximately 300 test panels of varying gage, material and design are being fabricated in the developmental bonding shop. Quality Control will inspect these panels prior to engineering testing, using nondestructive methods. The following systems will be used to evaluate panels and correlated in order to produce the optimum quality detection system:

- Liquid crystal
- Eddy current
- Sonic resonator
- Ultrasonic tester (C-Scan)
- Fokker bond tester

##### (2) Percussive Welding Development

Percussive welding is being investigated because of a need for a simple method to produce connections for wire terminals where high reliability, low electrical resistance, and high density wiring is required. Such connections must be resistant to vibration, shock, and temperature variation. The percussive welder was designed for high density, point-to-point wiring applications. Percussive welding provides connections stronger than the tensile strength of the wire joined, which are resistant to vibration, shock and temperature variation. This technique allows a high packing density, which permits more connections in less space at reduced weight. It also reduces heat transfer and the possibility of damage to heat sensitive components and eliminates most problems of surface contaminants.

This activity started in late April, with expected completion in December, 1966.

III. Description of Technical Progress (continued)

II. AIRFRAME STRUCTURE

1100. Airframe Structure, General

11001. TITANIUM ALLOY DEVELOPMENT

Tensile properties after exposure to 450°F and 550°F at 25 ksi for 1000 hours are shown in Table E for duplex annealed Ti-6Al-4V, beta-STA-1150 treated Ti-4Al-3Mo-1V, beta-STA-1050 treated Ti-4Al-3Mo-1V and duplex annealed Ti-4Al-3Mo-1V. Future data will include results from exposure of these heat treated specimens to the tabulated conditions for 2,500 hours.

Table E. Stability Exposure Data

Exposure	UTS (ksi)	Y.S. (ksi)	R.A. %	% El.
Ti-6-4 Duplex Annealed				
none	148.8	142.1	38	14
450°F 1000 hr	151.0	142.9	38	15
550°F 1000 hr	156.5	145.2	35	12
Ti-4-3-1 Beta-STA-1150°F				
none	154.8	137.2	16	7
450°F 1000 hr	161.7	140.7	17	7
550°F 1000 hr	163.0	141.2	15	5
Ti-4-3-1 Beta-STA-1050°F				
none	175.0	154.5	10	4
450°F 1000 hr	181.5	156.3	10	4
550°F 1000 hr	177.9	150.3	10	4
Ti-4-3-1 Duplex Annealed				
none	138.0	126.0	54	18
450°F 1000 hr	133.5	124.0	53	17
550°F 1000 hr	133.1	124.0	51	16

11002. HIGH-STRENGTH STEEL EVALUATION

Forged billets of 4330M, 4340M, H-11, 9Ni-4Co (0.30 and 0.45C), and maraging (18 percent Ni) 250 steels are being evaluated to provide alloy selection data. Document D6A10093-1 describes the test results obtained in these steels using various heat treatment. Fracture toughness in air and environmental crack growth resistance in 3-1/2 percent

D6-18110-5

### III. Description of Technical Progress (continued)

#### 11002. High-Strength Steel Evaluation (continued)

NaCl solution for several heats of selected heat treatment of the above steels are shown in Figs. 35 and 36. Future testing will include fatigue and round notched specimen hydrogen embrittlement tests.

Main landing gear torsional links have been forged from 9Ni-4Co-0.45C steel billets from Republic Steel Corporation by the Steel Improvement and Forge Company. One of the forgings was sectioned at the Steel Improvement and Forge Company. Table F shows the tensile and hardness properties obtained when specimens were Bainitic treated at 465°F. Two remaining forgings will be sectioned and tensile, charpy, and fracture toughness tests will be made at Boeing.

#### 11003. STRUCTURAL ALLOWABLES

##### (1) Shear Webs

Three light gage shear panels have been life tested to evaluate the effect of repeated web buckling on the spotwelded attachments of web stiffeners. The panels had .020 Ti 6-4 Condition I webs spotwelded to Ti 6-4 Condition III extruded zee stiffeners. The panels were tested in a picture frame test jig with loads applied at two diagonally opposite corners. A typical shear panel and test setup are shown by Fig. 37.

Cyclic tension loads varying from 2000 to 150 pounds were applied to the first panel. Panel shear flows resulting from the maximum tension load approximates maximum one factor loading on a typical wing rib. After 100,000 cycles produced no damage, the loads were increased to approximately a 3.1 factor loading of 6200 and 450 pounds. After an additional 35,000 cycles, several small cracks were noted in the web near the spotwelds. Panel failure occurred at a total of 152,000 cycles.

Small cracks in the web near spotwelds were found in the second panel after 36,000 cycles of 6200-450 pound loading. Panel failure occurred at 75,000 cycles.

Small cracks began in the third panel at 153,000 cycles for a 2.05 factor condition of 4100-300 pound loading and failure occurred at 380,000 cycles.

The results of these tests indicate that spotwelded attachments of web stiffeners are adequate for repeated applications of shear produced buckling loads.

Manufacturing of the panels for verification of Ti 6-4 shear allowables have been completed. These panels are similar in design to those of D6-17488-4. Start of test on this program has been rescheduled to early June.

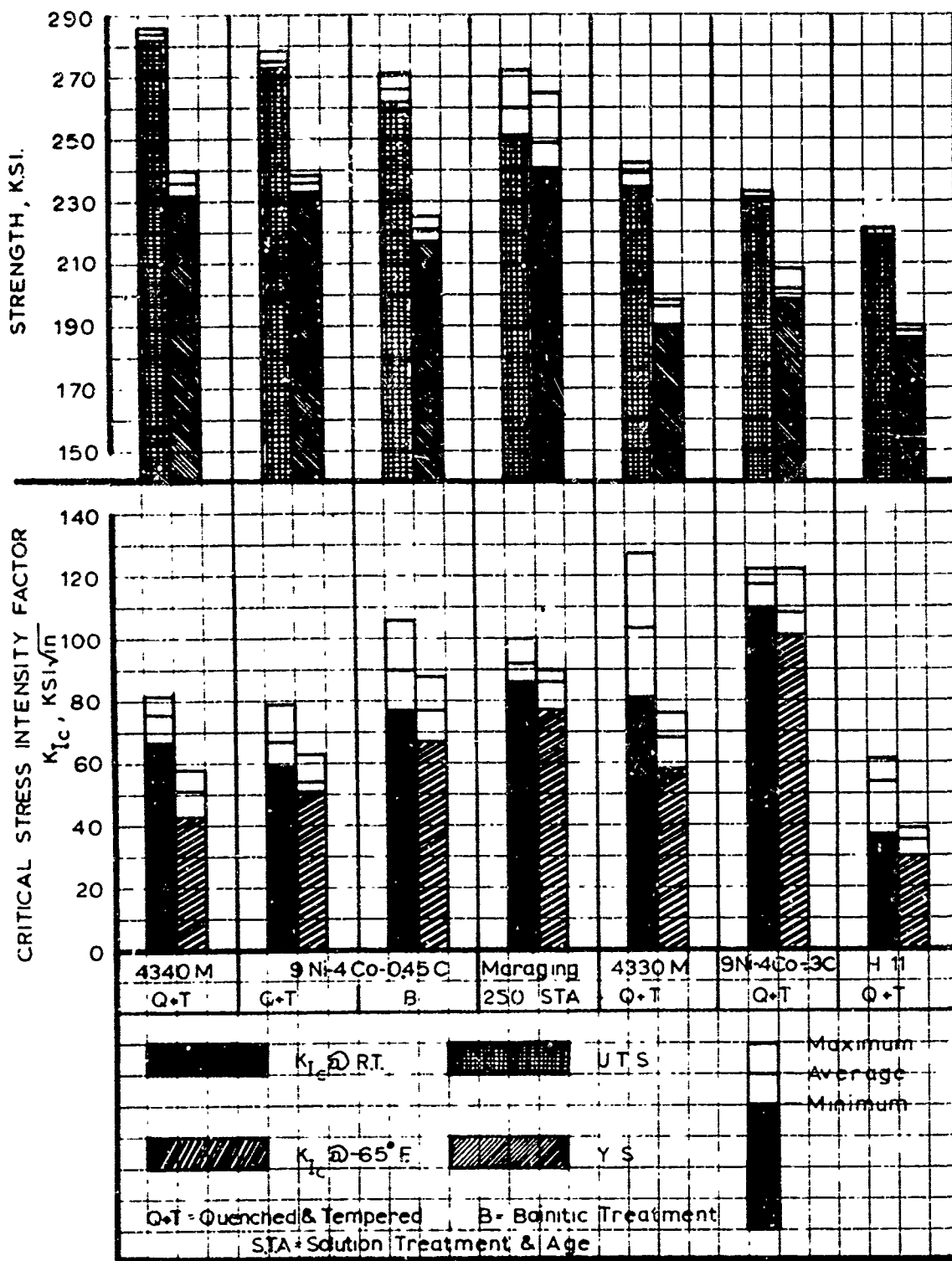


Figure 35. Tensile and Fracture Toughness Data from Three Heats of Each Alloy

D6-18110-5

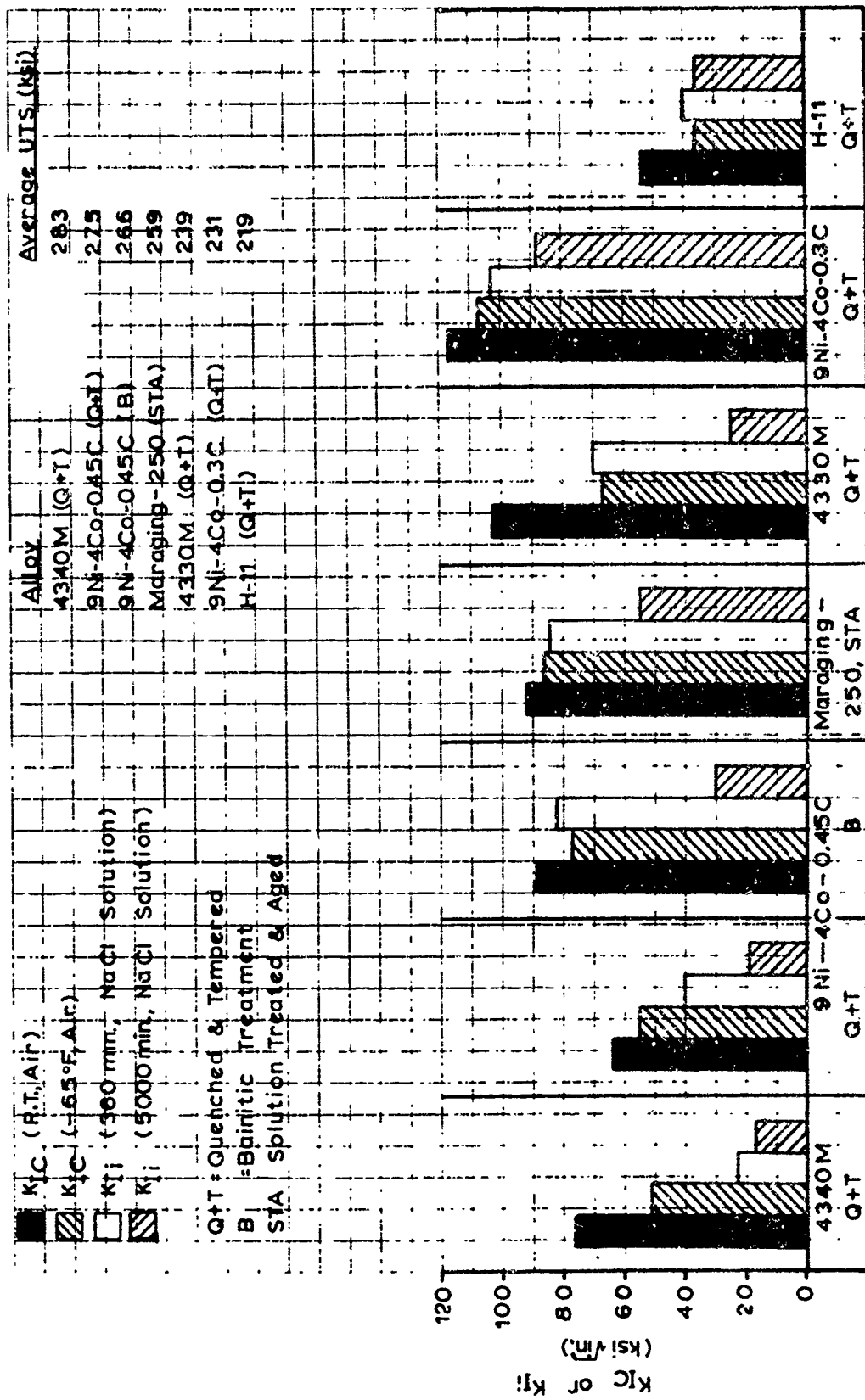


Figure 36. Average Stress Intensity Factors for Three Heats of Each Alloy

Table F. Properties of 9Ni-4Co-0.45C Bainitic-Treated Steel

Grain Direction	Spec. No.	F <sub>tu</sub> , ksi	F <sub>ty</sub> , ksi	% Elong. in 4D	% R.A.	Hardness R <sub>c</sub>
Long Transverse	1	267	---	12.0	53.5	50
	1-1	265	217	12.0	50.3	50
	1-2	267	225	12.0	51.1	50
Longitudinal	2	267	221	13.0	62.4	51.5
	2-1	267	221	13.0	60.7	51.5
	2-2	277	231	13.0	43.7	51.5
Short Transverse	3	279	233	10.0	41.2	51
	3-1	279	229	10.0	47.6	51
	3-2	277	231	10.0	42.9	51
Longitudinal	4	279	236	13.0	59.7	51.5
	4-1	277	234	12.0	58.7	51.5
	4-2	279	236	12.0	60.1	51.5
Short Transverse	5	273	228	10.0	45.9	51
	5-1	277	231	10.0	32.8	51
	5-2	275	228	10.0	45.0	51

D6-18110-5



Figure 37. Typical Shear Panel and Test Setup

D6-18110-5

### III. Description of Technical Progress (continued)

#### 11003. Structural Allowables (continued)

##### (2) Compression Panels

Column and crushing tests for verification of T1 6-4 allowables have been completed on four panels of a program similar to that of D6-17488-5, Page 71. These panels were similar to the Type 1 panels of D6-17488-1. Test results are shown below:

<u>Panel Length, in.</u>	<u>Test Temperature</u>	<u>Column Load kips</u>	<u>Crushing Load kips</u>
46.5	70°F	498	717
46.5	200°F to 500°F	402	586
73.5	70°F	319	766
73.5	500°F	300	552

Basic material property tests for these panels are being conducted. Comparison of test versus predicted loads will be made when results of material property tests are available.

Manufacturing has been completed on the remaining panels of this program with testing scheduled upon completion of test instrumentation.

##### (3) Honeycomb Allowables Testing

Seven polyimide honeycomb sandwich panels have been tested in compression and developed up to 88KS1. Test results and the panel configuration are shown in Fig. 38.

Preliminary test of a bias weave honeycomb fiberglass core show a 25 percent increase in shear strength and a 300 percent increase in shear rigidity over a normal weave core. These improvements in core properties are expected to develop higher panel allowables. Bias weave core is being incorporated into current test panel designs.

#### 11004. STRUCTURAL DESIGN CRITERIA

##### (1) Surface Waviness

Testing on the honeycomb panel mounted on the thermal box was resumed on schedule. The panel had been reinforced around the inside edges and the supporting ribs had been modified to give the same degree of torsional stiffness as corrugated ribs. Although the panel was able to sustain higher spanwise compressive or chordwise compressive loads than before, local edge instability remained the limiting factor. Rib chord rotation, however, was virtually eliminated. The box is currently being modified externally in a manner that simulates the effect of a thicker outer skin in the tapered edge areas of the honeycomb panel. Testing was resumed in late May.

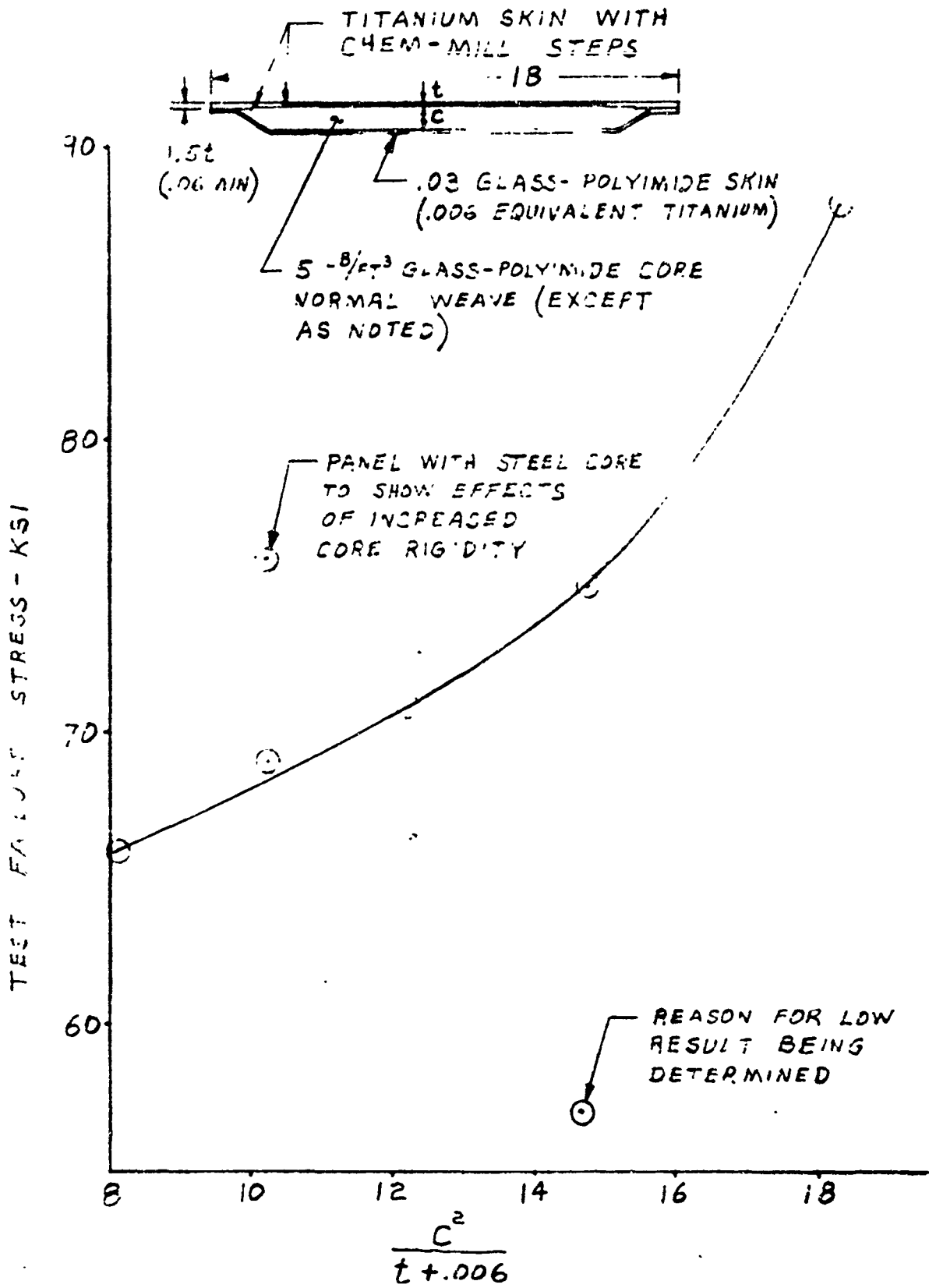


Figure 38. Honeycomb Panel Test Allowables

D6-18110-5

### III. Description of Technical Progress (continued)

#### 11004. Structural Design Criteria ( continued)

The detail design of the horizontal stabilizer test structure was completed on schedule. It utilizes some components of the thermal box. A formal stress analysis of the structure is in preparation. The engineering fabrication and assembly of the test fixture and the manufacture, assembly and installation of the test structure are scheduled to support a start of test date in early October.

#### (2) Fail-Safe Tests

Two additional tests have been completed on the formed stiffener panel configuration representative of typical fuselage structure (Ref. D6-18110-1, page 54 and D6-18110-4, page 121).

The first configuration tested was a completely severed stiffener with an initial skin crack 1.14 inches in length. The panel was cycled at a maximum gross area stress of 40 ksi and  $R = .05$ . At 93 cycles the left side of the crack grew into a fastener hole at the adjacent stiffener and crack growth was arrested. The right side extended between fasteners at the adjacent stiffener. The test was stopped at 101 cycles with a crack 11.13 inches in length. The final crack configuration is shown by Fig. 39.

The panel was repaired and a second configuration of a partially severed stiffener with an initial skin crack .96 inches in length was tested. Only the skin flange of the stiffener was cut leaving the webs and outstanding flange intact. The panel was cycled at a maximum gross area stress of 40 ksi and  $R = .05$ . At 1508 cycles the partially cut stiffener failed. Crack extension due to stiffener failure was approximately .35 inches. The crack length after stiffener failure was 4.38 inches. At 1529 cycles a static load condition of 40 ksi was held, during which the left hand side grew into a stiffener fastener hole. No slow growth occurred on the right hand side. Another 40 ksi static load condition was applied producing slow crack growth on the right hand side. After approximately five minutes of slow crack growth, the crack had extended 1.56 inches and testing was discontinued. Both sides of the crack had extended past the adjacent stiffeners to a length of 19.57 inches. The final crack configuration is shown by Fig. 40.

Two additional tests have been completed on the zee skin-stiffener panel with intermediate straps (Ref. D6-18110-1, page 54 and D6-18110-4, page 121).

The first configuration tested was a completely severed stiffener with an initial skin crack 1.36 inches in length. The panel was cycled at a maximum gross area stress of 25 ksi and  $R = .05$ . After 4781 cycles the lefthand side of the crack grew into a fastener hole at the adjacent strap. After another 1019 cycles had produced no additional crack growth, the maximum gross area cycling stress was increased to

D6-18110-5

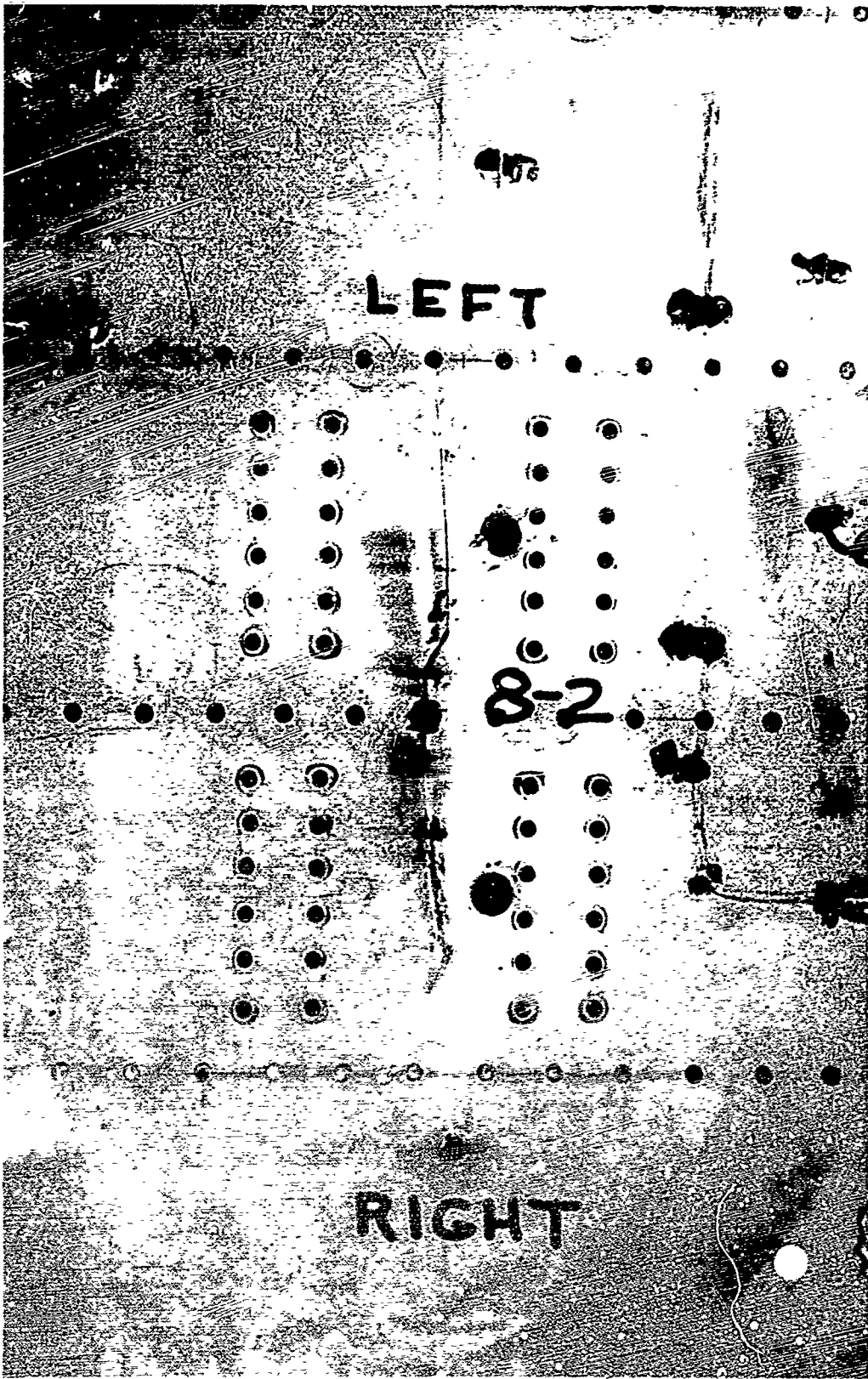


Figure 39. Final Crack Configuration

D6-18110-5

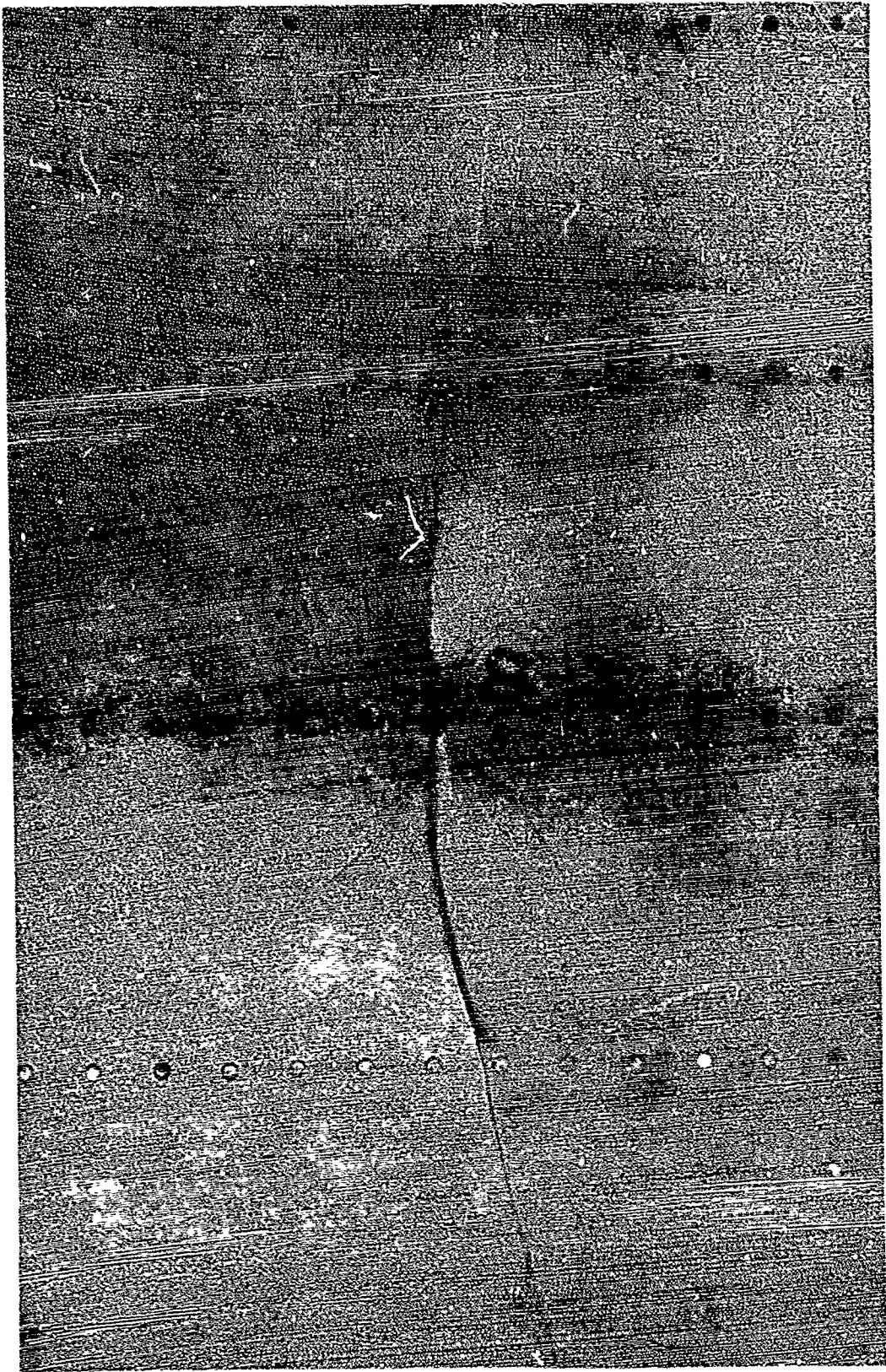


Figure 40. Final Crack Configuration

D6-18110-5

### III. Description of Technical Progress (continued)

#### 11004. Structural Design Criteria (continued)

40 ksi. At 6173 cycles a crack started at the fastener hole on the left-hand side and grew into a fastener hole at the adjacent stiffener at 6260 cycles. No growth occurred on the righthand side during this time. The test was discontinued at this point. The final crack configuration is shown by Fig. 41.

The second configuration tested was a partially severed stiffener with a 1.22 inch starter crack in the skin. Only the skin flange of the stiffener was cut leaving the web and outstanding flange intact. The panel was cycled at a maximum gross area stress of 40 ksi and  $R = .05$ . After 1436 cycles the partially cut stiffener failed. The skin crack was 10.90 inches in length at the time of stringer failure. No additional crack extension occurred due to stiffener failure. After 1460 cycles the righthand side of the crack had grown past the adjacent strap and into a fastener hole at the stiffener. The final crack configuration is shown by Fig. 42.

Designs have been released for three panel configurations to be used for validation testing of Ti 6-4 structure. Two panels of each configuration shown by Fig. 43 will be tested. Baseline crack growth and fracture toughness data will be obtained for the skins of each panel type.

#### 11005. STRUCTURAL LOADS AND TEMPERATURES

##### (1) Thermal Analysis - Titanium Wing Box

Work is progressing on the release of Document D6A10154-1, "Comparison of Theoretical and Experimental Results for a Titanium Wing Box Subjected to Thermal and Applied Stresses." This document will be released soon. At the present time, the effect of high temperatures and stress on the strain gage readings is being evaluated. There appeared to be significant creep in the strain gage and/or bond, in the first few excursions to 500°F and high stress levels. The individual contributions of stress and temperature to the creep effect have not been evaluated independently, and further investigation is planned. The creep encountered under these conditions has a direct bearing not only on the results of the wing box test, but possibly on several other high temperature tests.

##### (2) Load Analysis

Detail load distribution and static aeroelasticity analyses are currently being conducted on the B-2707 configuration. Wing design bending moments are lower than for previous comparable configurations due to the following major effects:

(a) A more inboard center of pressure for "flaps down" condition exists since more effective inboard flaps were made possible by removing the engines from the wing.

D6-18110-5

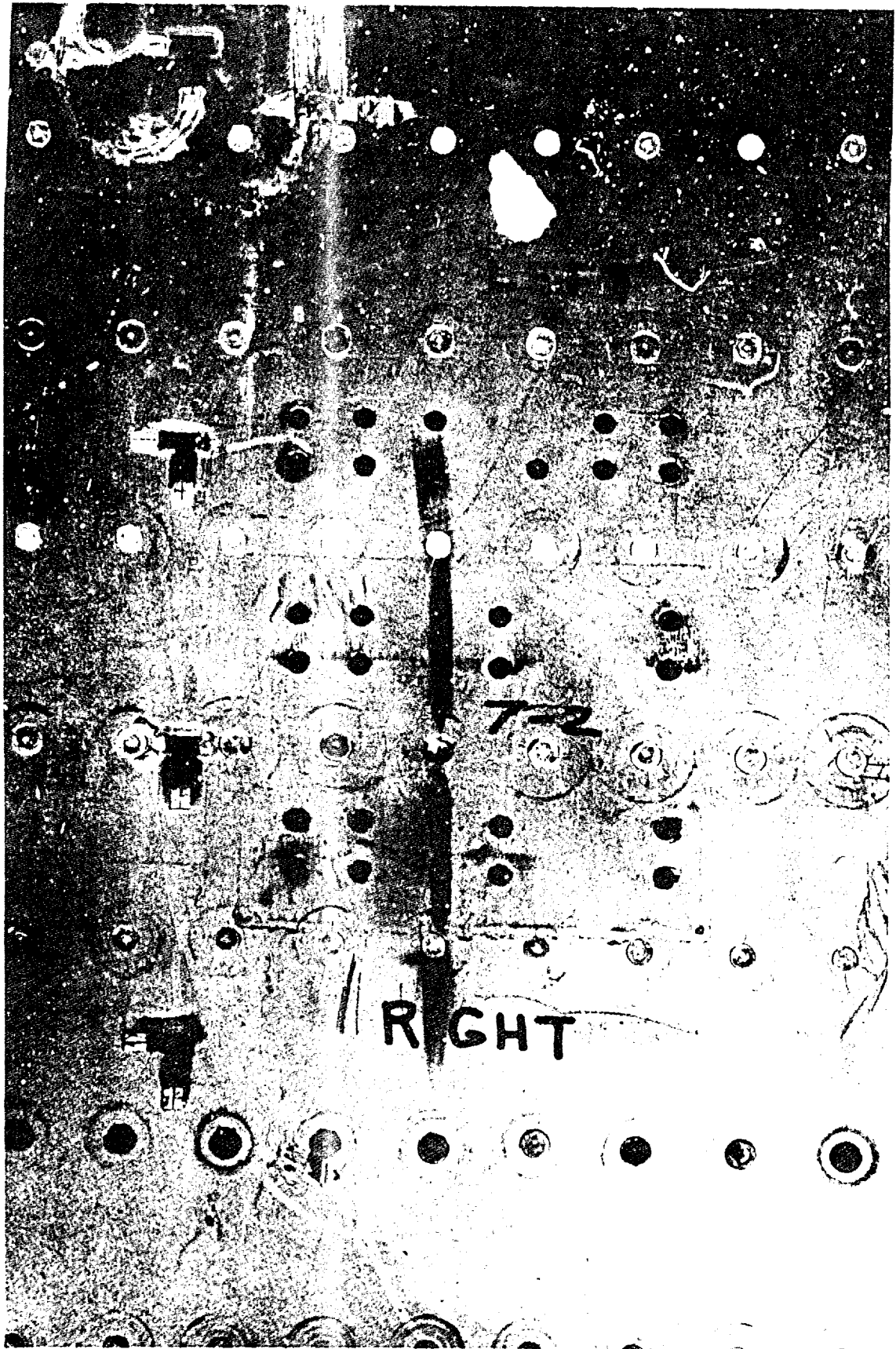


Figure 41. Final Crack Configuration

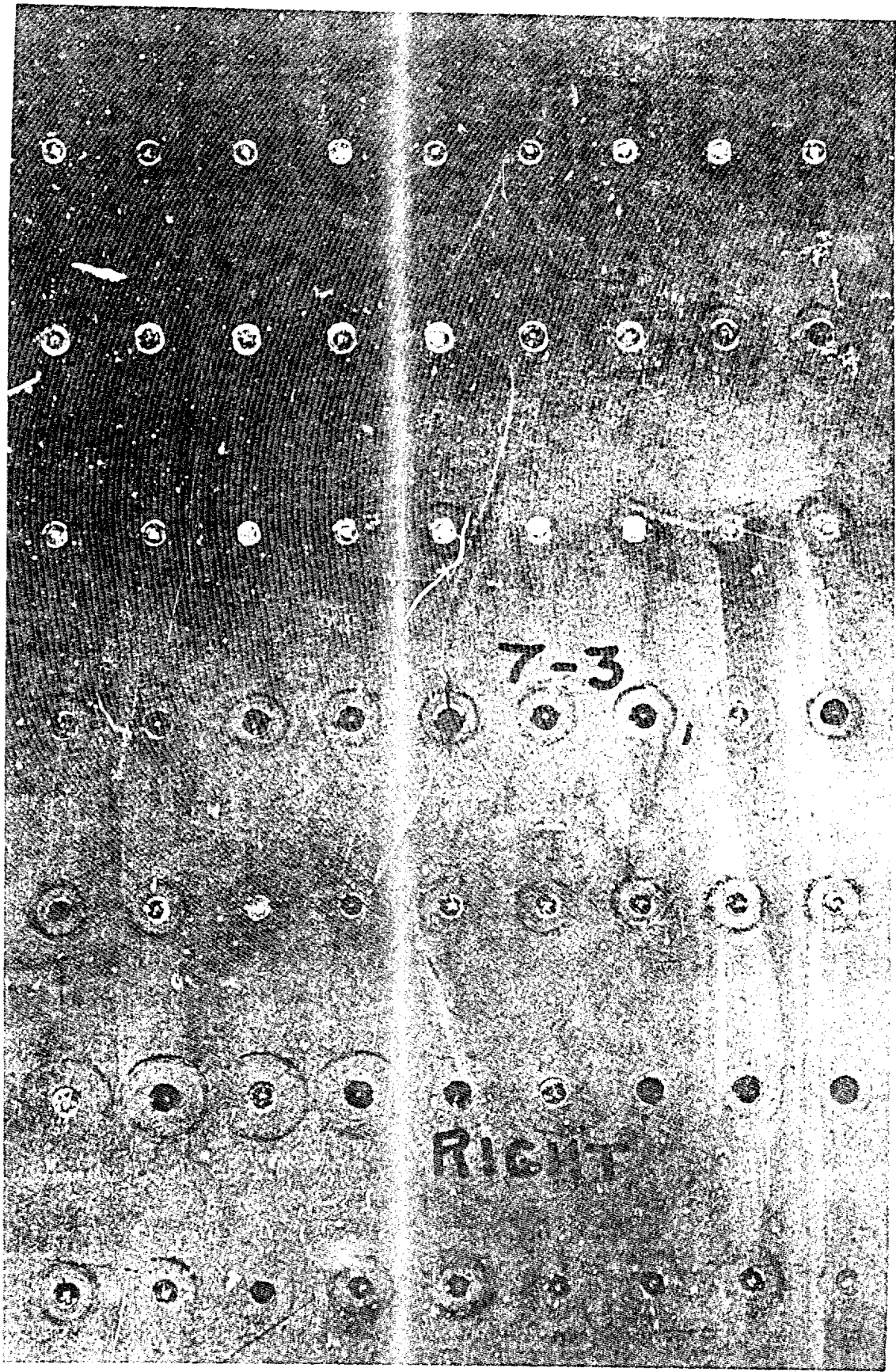


Figure 42. Final Crack Configuration

D6-18110-5

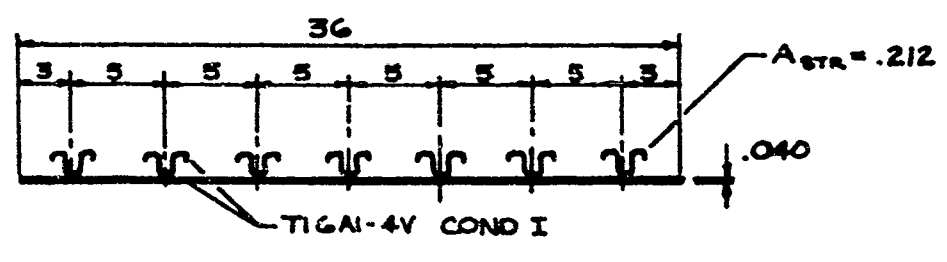
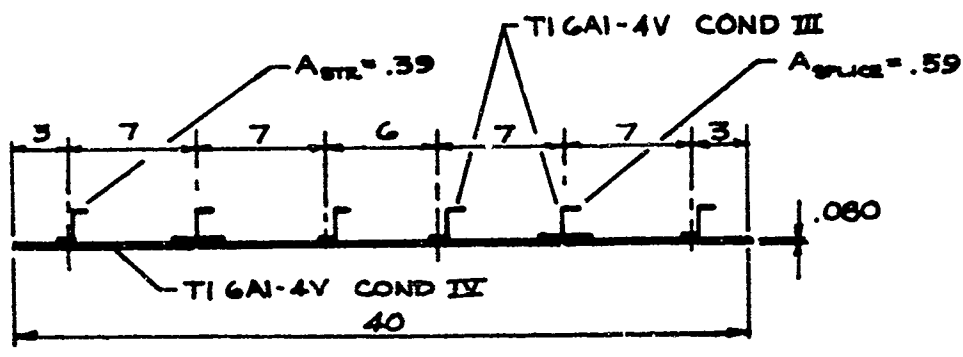
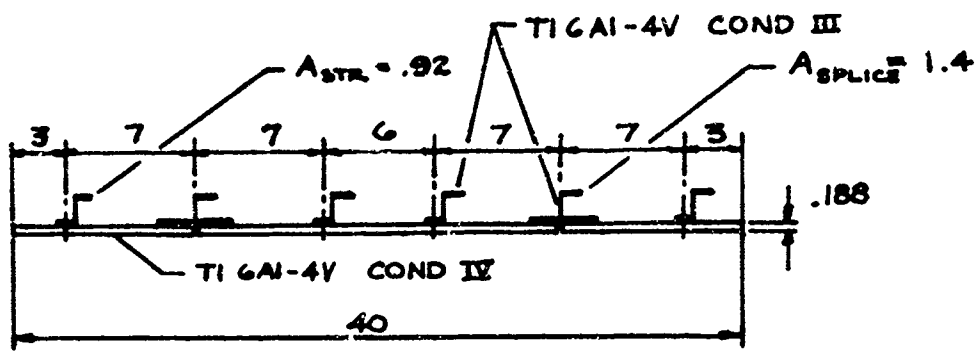


Figure 43. Fail Safe Panels

D6-18110-5

### III. Description of Technical Progress (continued)

#### 11005. Structural Loads and Temperatures (continued)

(b) The airplane center of gravity is further aft with respect to the wing center of pressure requiring less negative balancing horizontal tail loads. As a result, the wing carries less total load.

(c) More structural depth allows increased fuel volume in the outboard wing.

Wing fatigue loads, expressed in terms of percent of design loads, will also be reduced significantly due to the more favorable flap arrangement.

Results of preliminary static aeroelastic analyses indicated that the total airplane aerodynamic center shift due to flexibility for the B-2707, is considerably less than in the 733-390 type configuration as shown in Fig. 44. This effect is due primarily to inertia load relocation (engines and fuel). A stabilizing increment in aerodynamic center location is provided by the aft body and horizontal tail flexibility.

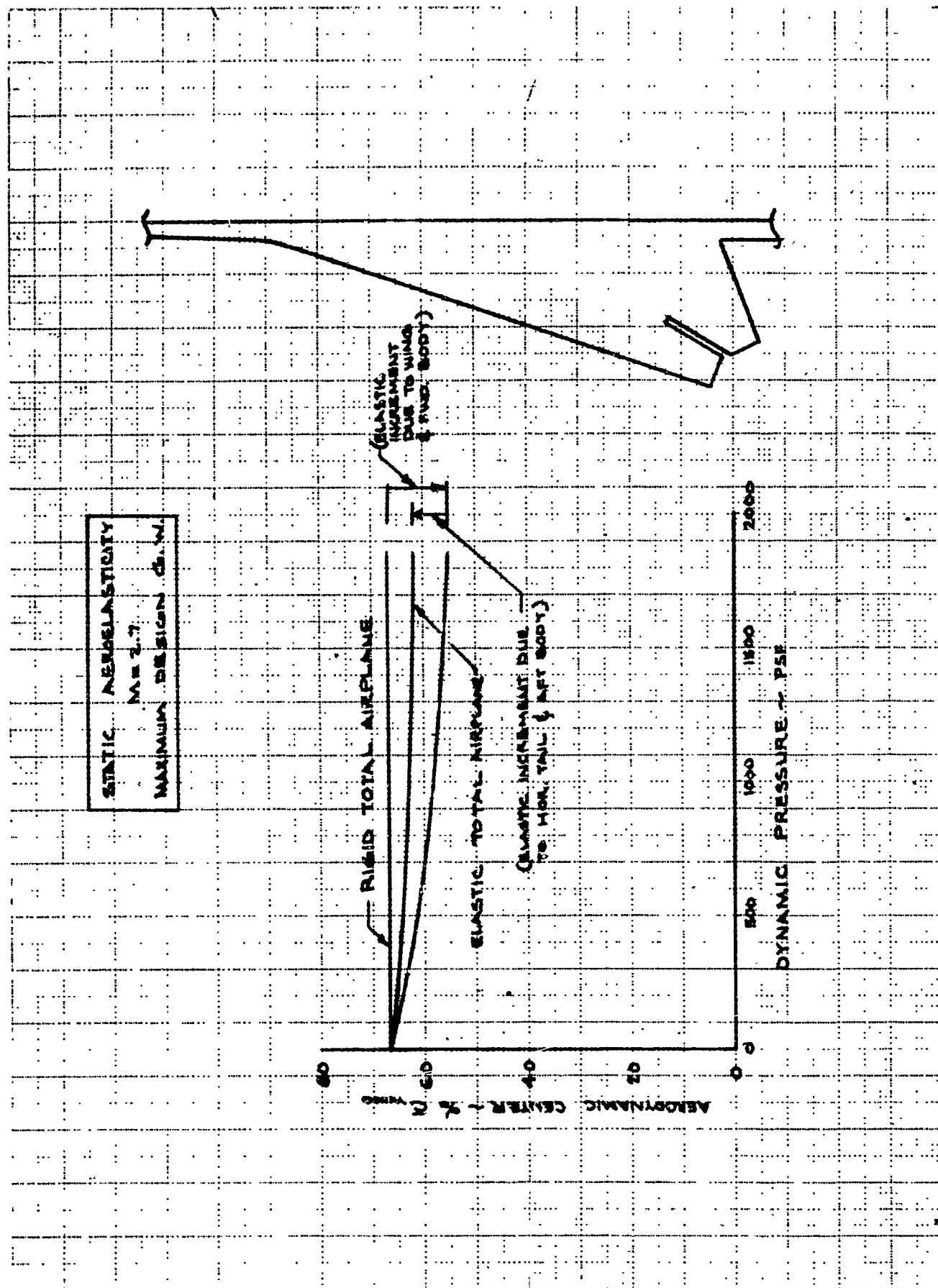
#### (3) Dynamic Loads

The ride comfort study of the Boeing 733-390 SST configuration has been completed. The results of these power spectral analyses are presented in Fig. 45 as vertical load factor exceedance curves calculated for the pilot station, the airplane center of gravity, and the aft passenger compartment. For comparison with a current jet transport aircraft, data calculated for the center of gravity position (no other location analyzed) of the Boeing 720B is also shown. These results for both the 733-390 SST and the 720B represent turbulence exposure while flying their respective typical mission profiles with the SST SAS considered inoperative. In the case of the 733-390, load magnification due to flexibility is evident at the fore and aft fuselage positions. A reasonable accounting for similar body flexibility effects on the subsonic 720B will give statistical load levels at the pilot station of essentially the same magnitude as those anticipated for the 733-390 SST.

Additional ride comfort information is presented in Fig. 46 in RMS magnitude form. Fuselage distributions of the RMS vertical acceleration on the 733-390 airplane are shown for the most severe portions of subsonic climb and descent and for the midpoint of supersonic cruising. Comparative RMS values established during cruising are included for two current subsonic civil jet aircraft. This data emphasizes the favorable cruising ride qualities expected for the Boeing 733-390 airplane.

#### 11006. FLUTTER

A preliminary flutter evaluation test of the 733-414B wing, using a 1/20-scale semispan model (Fig. 47), was completed at the UWAL subsonic tunnel on April 15, 1966.



STATIC AEROELASTICITY  
 MAX 2.7  
 MAXIMUM DESIGN Q

RIGID TOTAL AIRPLANE  
 ELASTIC TOTAL AIRPLANE  
 (ELASTIC INCREMENT DUE TO WING & FUSELAGE)  
 (ELASTIC INCREMENT DUE TO WING & FUSELAGE)

DYNAMIC PRESSURE - PSE

AERODYNAMIC CENTER - % MAC

Figure 44. Static Aeroelasticity

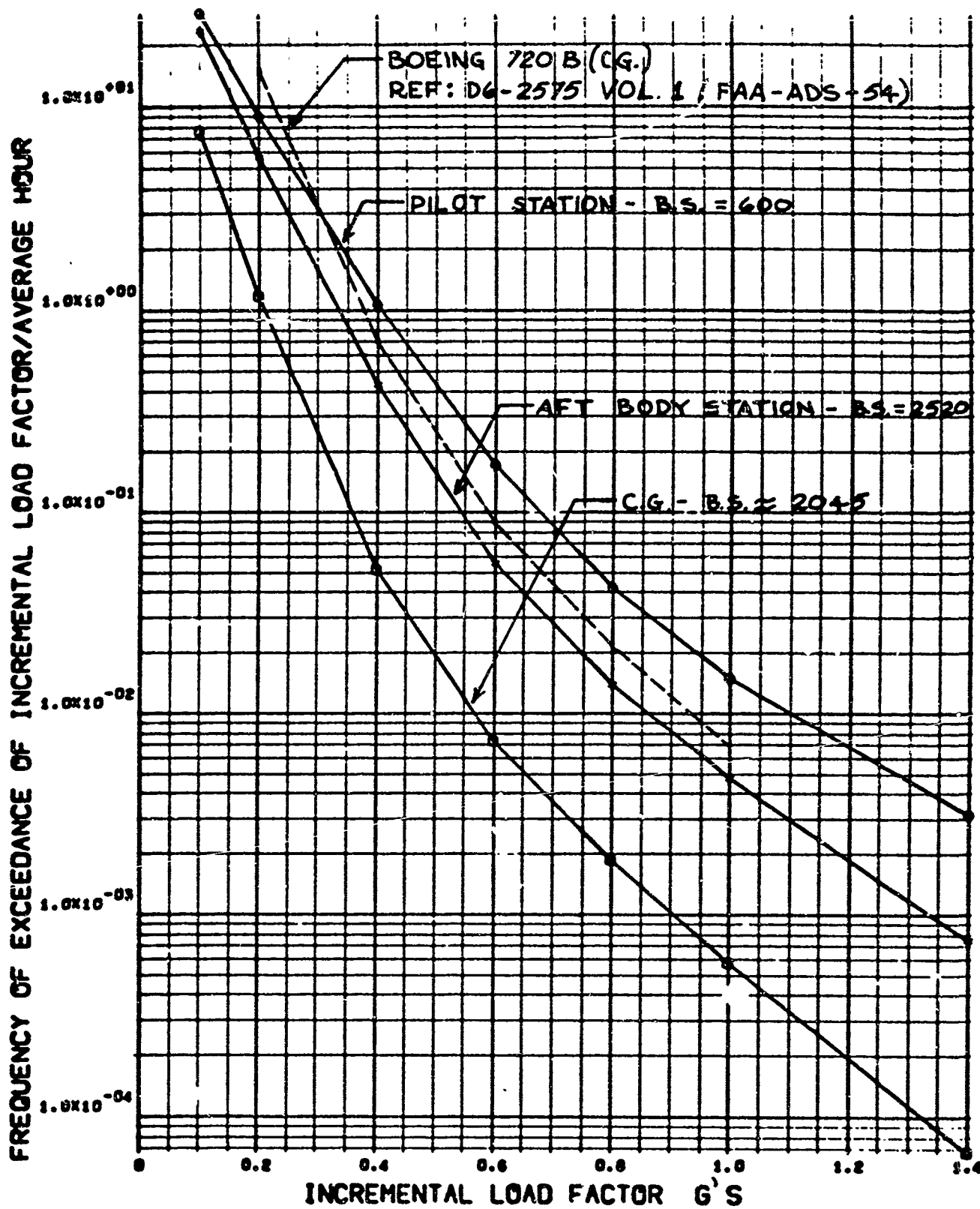


Figure 45. Exceedances of Incremental Body Accelerations Elastic Structure (Full Dynamics) SAS Inoperative

D6-18110-5

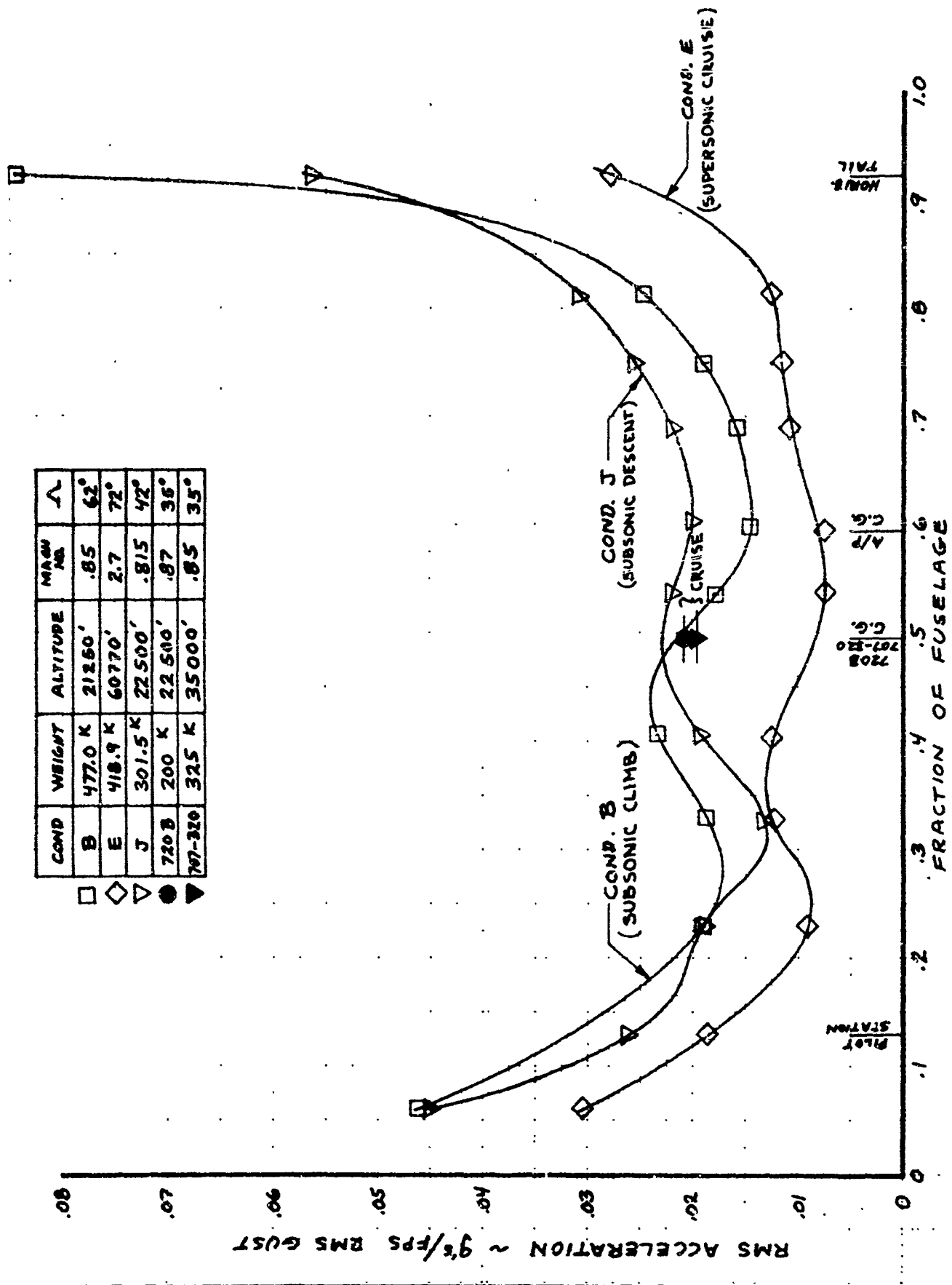
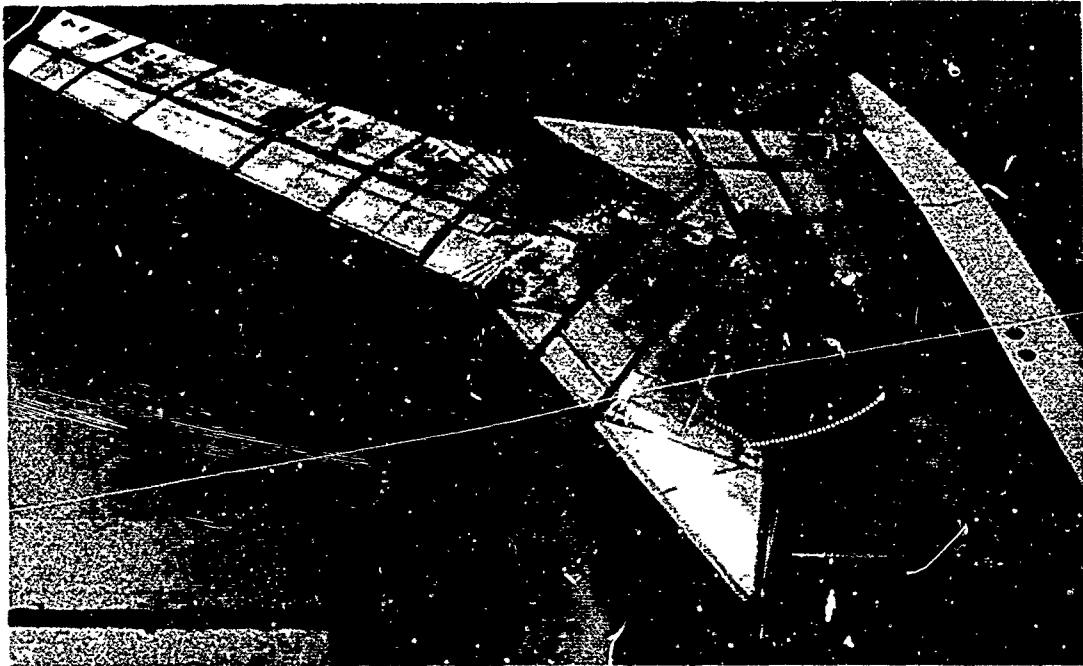
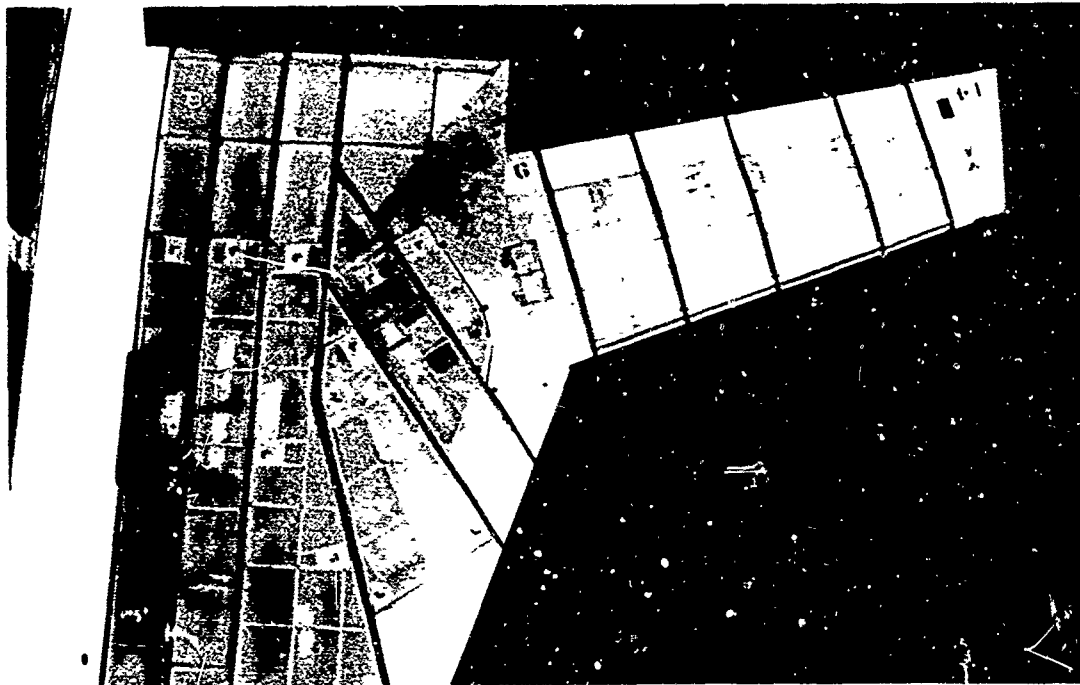


Figure 46. RMS Values of Fuselage Acceleration



Flutter Model



Test Installation

**Figure 47. 733-414 Wind Tunnel Installation**

D6-18110-5

### III. Description of Technical Progress (continued)

#### 11006. Flutter (continued)

Results indicate negative flutter margins for the strength-design wing (Fig. 48). Tests of a wing with a 50-percent increase in stiffness from the side of the body to the tip yielded satisfactory flutter speeds. Flutter speeds were lowest for wing fuel conditions of 50 percent of capacity or less (Fig. 49).

A supersonic flutter test of 733-390 type semispan wings and 733-362 fin was completed in the Boeing supersonic wind tunnel May 3, 1966 (Fig. 50). This was a follow-on test to the run last November.

The wing models were tested at sweep angles of 45, 60 and 72 degrees with outboard wing stiffnesses of 50, 75, and 100 percent of nominal -390 values. The results, shown in Fig. 51, indicate that:

- (1) At Mach numbers above 1.9 all wings were flutter free.
- (2) At 72 degrees of sweep, only wings with 50 percent of nominal stiffness showed flutter tendencies.
- (3) The wing is most critical for flutter in the vicinity of 60 degrees of sweep.

The fin, scaling the nominal stiffness and mass of the 733-362 design, was tested to  $q$ 's in excess of  $1.2V_D$  from Mach 1.4 to 3.5 without encountering flutter (Fig. 52). A low-damped flapping oscillation was present in the shaded region of Fig. 52.

#### 1101. Wing

##### (a) Design

Configuration design development work has progressed principally in the areas of leading edge slats, trailing edge flaps, landing gear support structure and wing-to-body attachment details.

##### (b) Tests

(1) For the 100-inch full-scale inboard and outboard wing pivot test section, the final engineering production drawing was released to Manufacturing on April 27. Fabrication is on schedule.

(2) For the 140-inch section of outboard wing fatigue box, final engineering production drawings were released to Manufacturing on April 15. Fabrication is on schedule.

(3) The 12-foot wing box, on which thermal and load tests were completed in February, is in the process of being fitted with a new

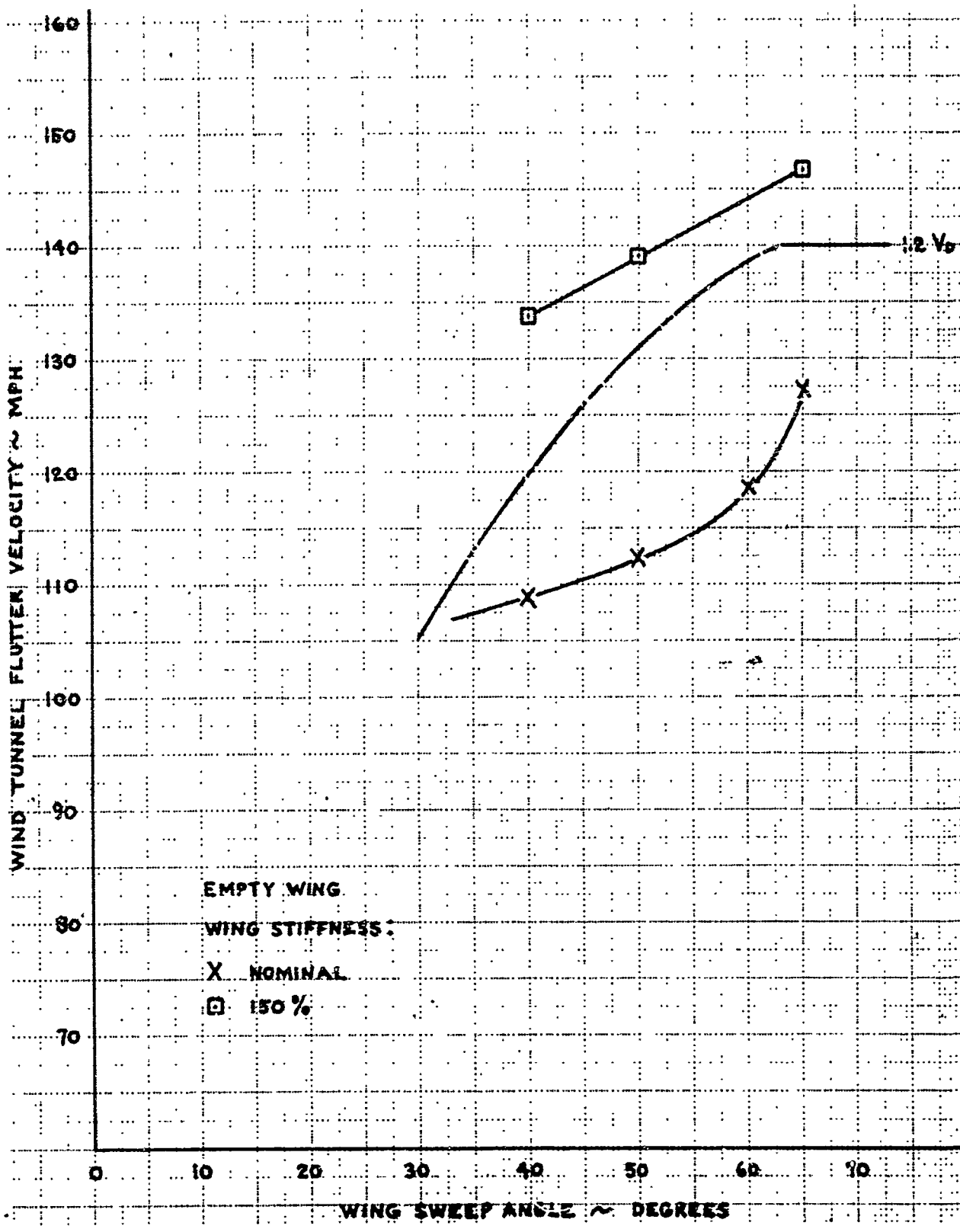


Figure 48. 733-414 Wing Stiffness Effects On Flutter

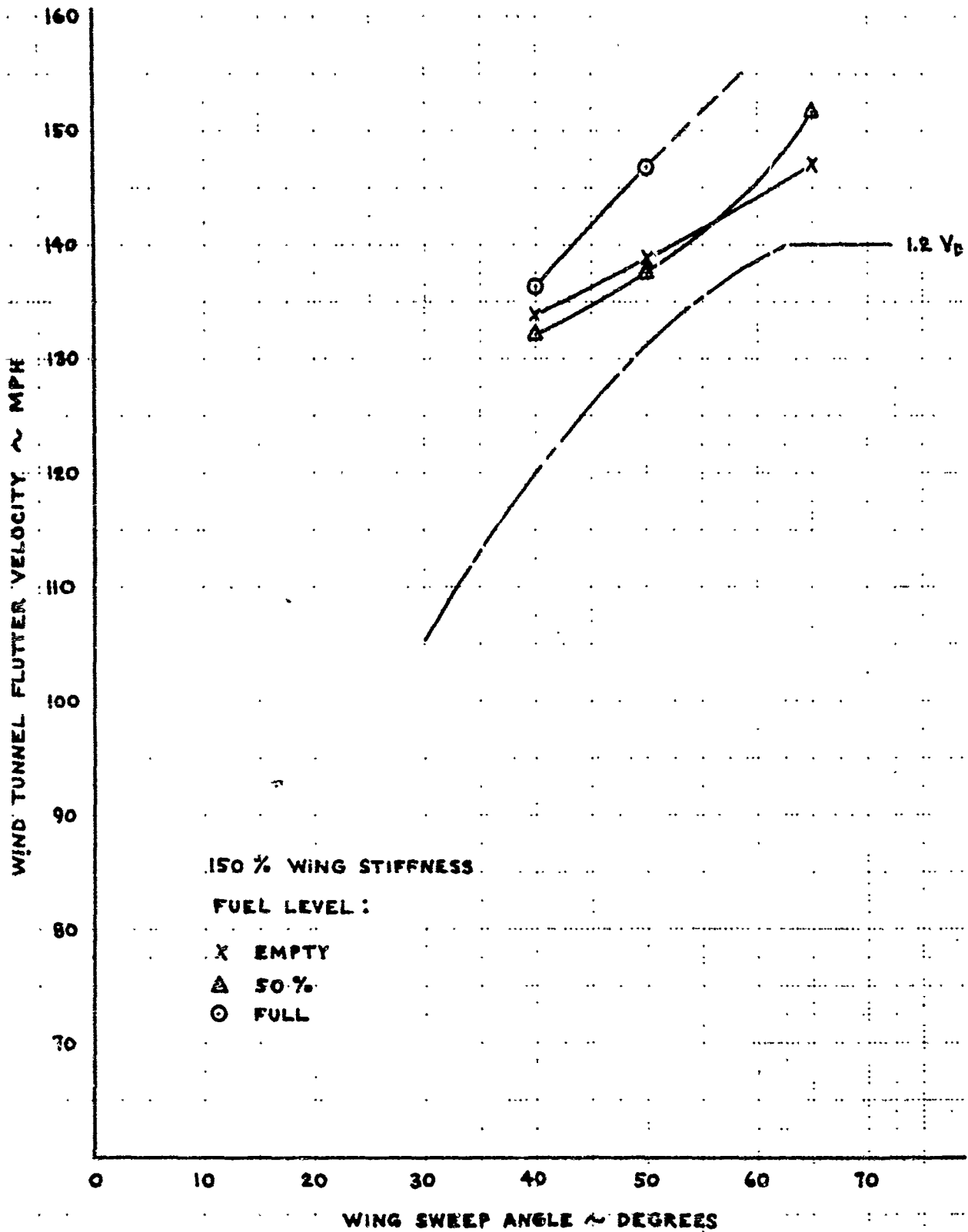
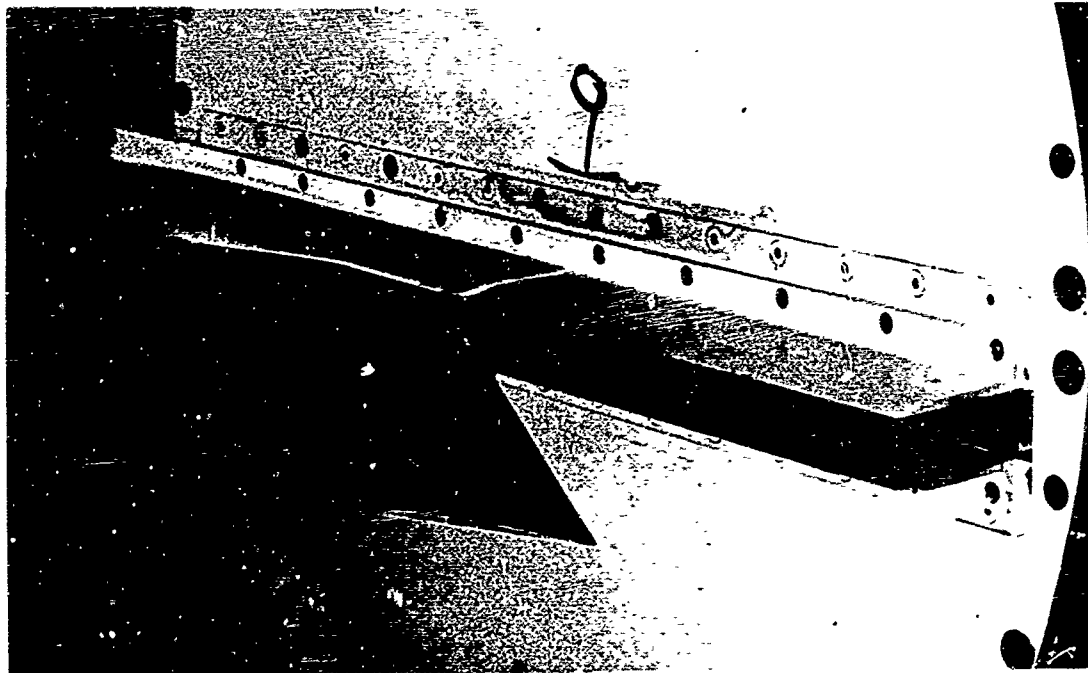
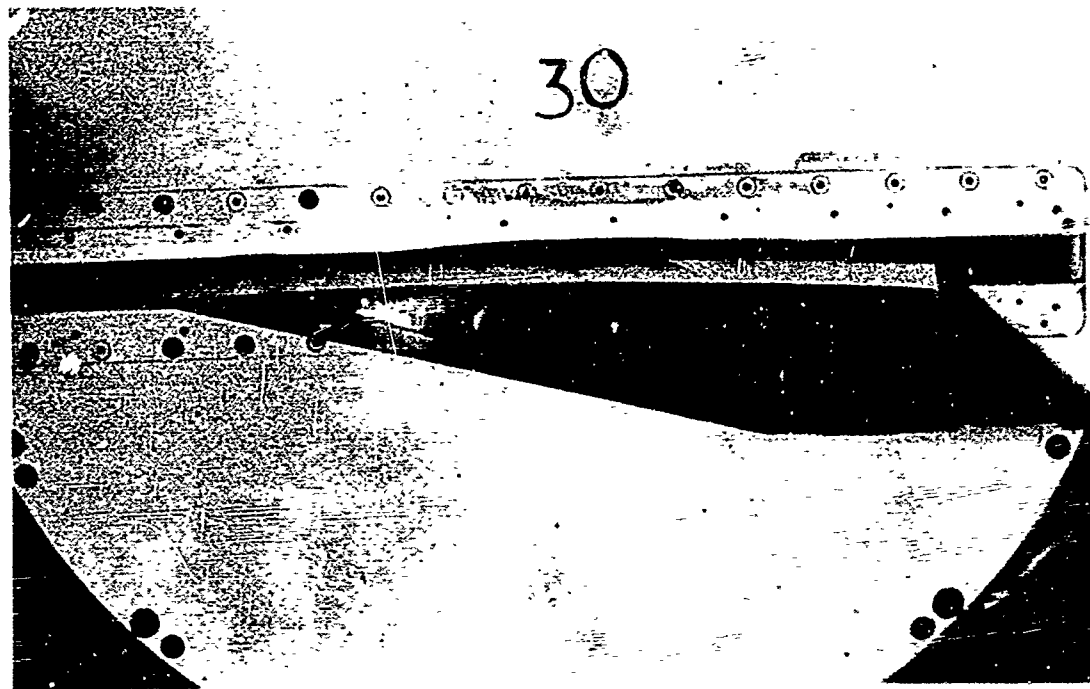


Figure 49. 733-414 Wing Fuel Effects On Flutter

D6-18110-5



Wing Installation



Fin Installation

Figure 50. Supersonic Flutter Test

D6-18110-5

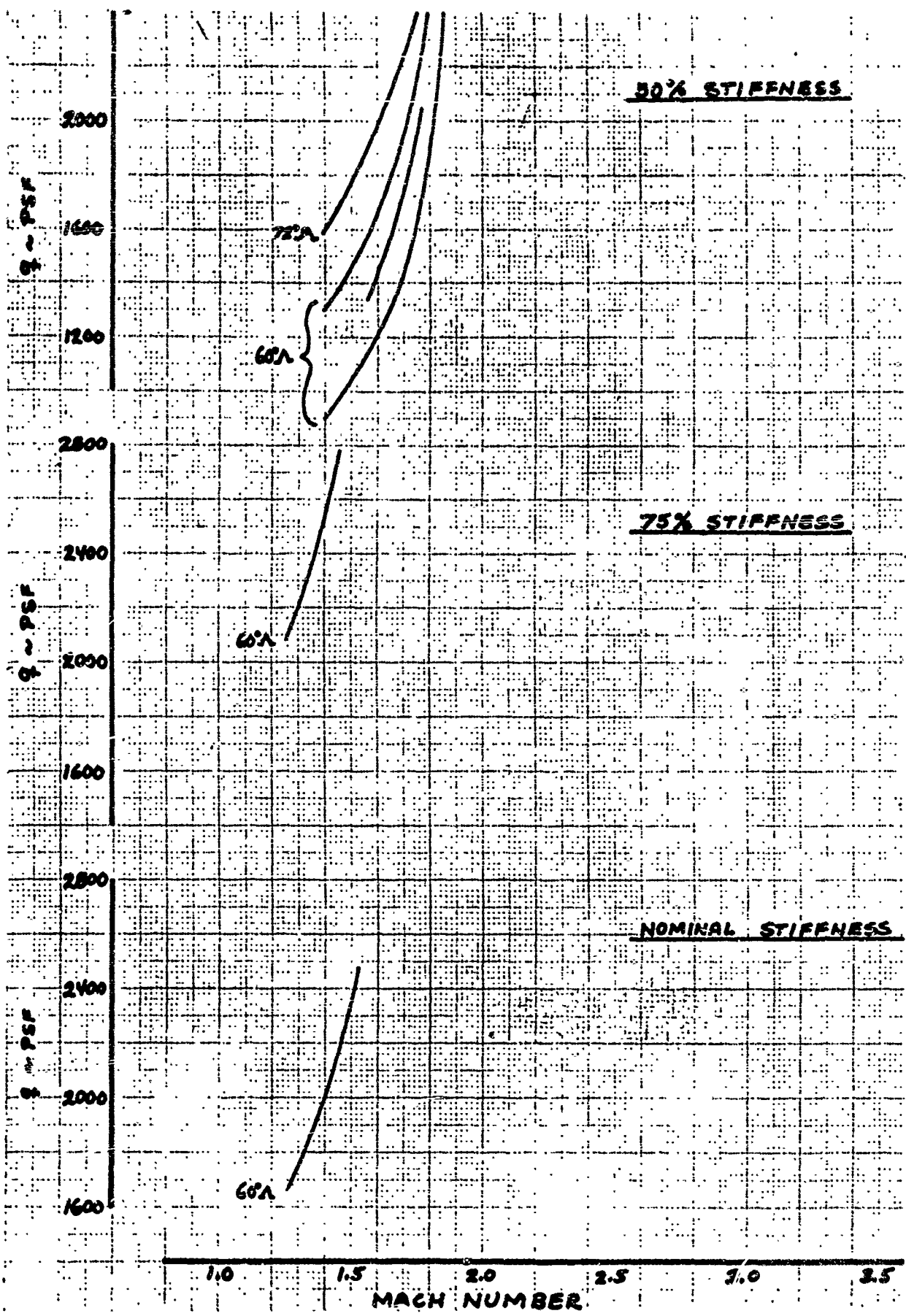


Figure 51. Supersonic Wing Flutter Test 733-390 Wing Configuration

D6-18110-5

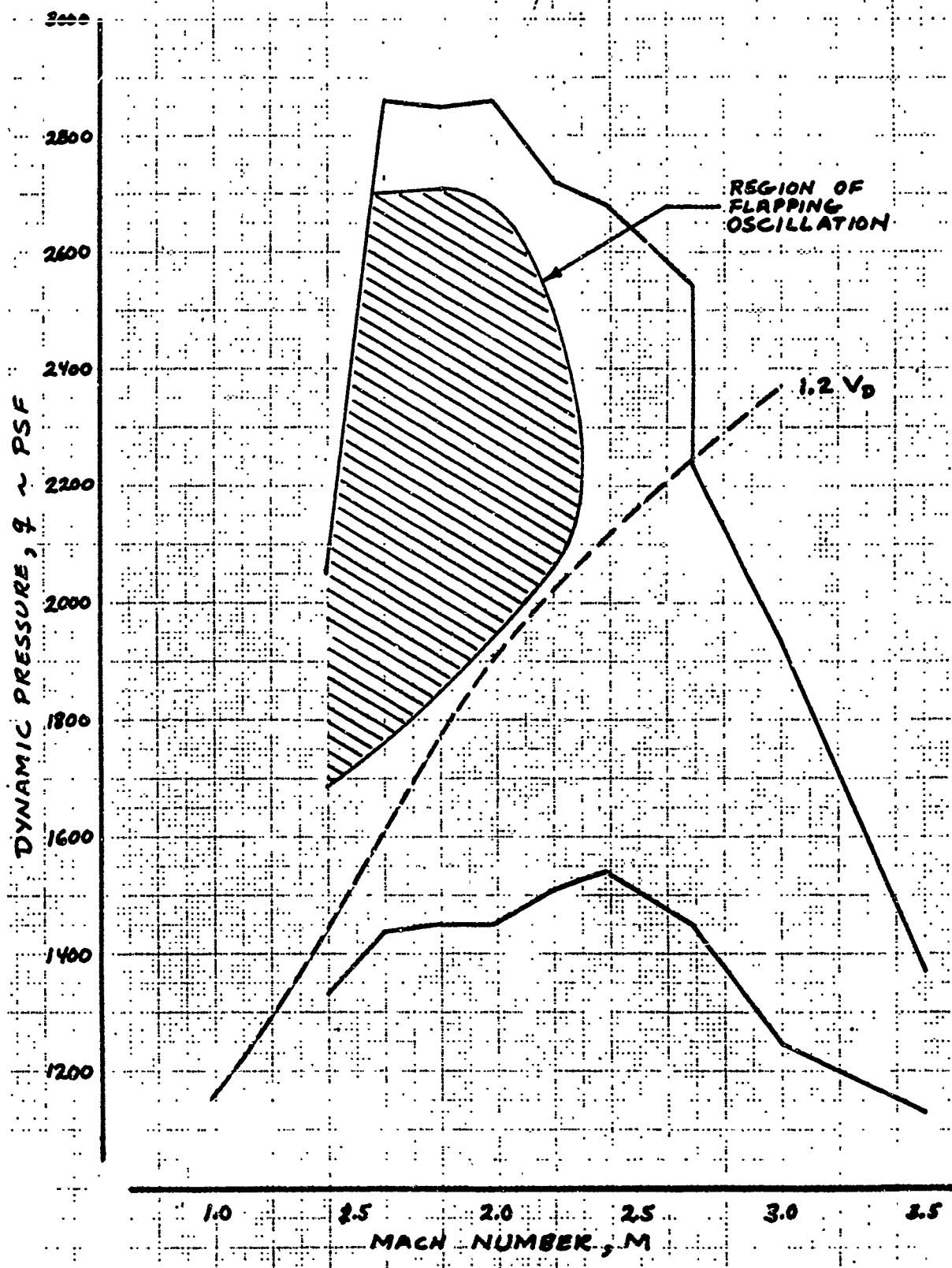


Figure 52. 733-362 Fin Test Envelope BSWT - SA894D-2

D6-18110-5

### III. Description of Technical Progress (continued)

#### 1101. Wing (continued)

6A1-4V lower surface for fail-safe testing. The installation is approximately 60 percent complete.

(4) The life-test program for the full-scale pivot bearing is continuing. Currently, 27,500 airplane flight load cycles have been applied. At 1-1/2 hours per flight this is equivalent to 40,000 flight hours.

At 26,808 cycles, a fatigue crack appeared in the titanium lug bearing support fitting, near the area of a previous crack. A stop-hole was drilled and crack detection wires installed in this local area; then the test was continued.

Several months ago, it became apparent that the existing titanium lug component part housing the test bearing had insufficient reserve fatigue life to life-test more than one wing pivot bearing. At that time, additional material was ordered for a replacement lug; this material is scheduled for delivery on June 6. Engineering drawings for a new pivot lug, incorporating several local detail design changes, were released to Manufacturing on May 2.

(5) In the quarter-scale wing pivot bearing development program, testing of bearings 11 and 12 (three-piece bearing of the "-3 modified configuration", referred to in the March Progress Report) is in progress. Bearing test pressure is 8,850 psi with a cyclic rate of 6 cpm; test temperature is 300°F. Two-hundred-fifty-five thousand cycles have been accumulated without failure and the test is continuing.

#### 1104. Fuselage

The nose configuration selected for the B-2707 uses a single fixed pivot in lieu of pivot plus visor to obtain approach and landing vision. This feature reduces complexity of nose and follows a Boeing filed patent disclosure 2,778,586 of May 2, 1955.

Other features of the nose design provide flat seal planes between the rotating surfaces resulting in efficient environmental seals. The grooved area of the forebody fades out at the aft end of the nose radome to simplify the radome construction. Windows in the forebody ahead of the pressure section are reduced in size and are located to provide optimum cruise vision in agreement with data being derived from extensive testing in the Boeing aerospace simulator at Kent, Washington.

The lower location of the wing strake on the body provides for more efficient use of transverse body floor and skin structure for carrying strake loads at the strake-body connection.

### III. Description of Technical Progress (continued)

#### 1104. Fuselage (continued)

The latest arrangement providing body storage of the main landing gear has resulted in a re-evaluation of the structural configuration of the aft lower lobe of the fuselage between the wing and stabilizer. The body skin in this area is vertical between the maximum half breadth and the keel line forming a deep vertical beam on each side. The lower chord of the beam is stabilized approximately every sixty inches by a body bulkhead. This bulkhead also distributes the pressure loads from longitudinal floor beams to the side-beams. The wing and stabilizer ribs at the side of the body are shear connected at both upper and lower surface. This arrangement provides uninterrupted structure for body bending and shear. The overall aft body lower lobe arrangement also provides good space clearances for systems installations.

Section 41 full size cab test structure program is on schedule. All planning of part fabrication has been released to Norair, and Norair is completing tools for detail part fabrication and has just started detail part fabrication.

#### 1106. Landing Gear

The B-2707 airplane utilizes a main landing gear arrangement different from those shown on previous configurations.

Four-four wheel truck gear units are used in a staggered arrangement forward and aft of the wing center section box.

The two forward gears which are attached to the front spar of the wing box are located approximately 28 feet apart to provide turning and side load stability. These two gears retract forward and are stowed in the wing strake.

The two aft gears are attached to the wing box rear spar and retract aft to a stowed position within the body below the floor. To enable the airplane to be steered in a conventional manner, with a minimum of tire scrubbing, the aft-main gears are provided with steering actuators which are integrated with the nose gear steering system. This steering system is designed to operate during all ground handling cycles.

The use of four-wheel trucks (similar in concept to those used on current subsonic jet) allows for maintenance procedures basically the same as those now used, with little change in standard equipment.

The separation distance between the main gears and distribution of the load provides for a flotation capability better than that of the DC-8-55 (328,000 pounds) on both rigid and flexible pavements. This capability can be achieved for airplane weights substantially above 600,000 pounds.

### III. Description of Technical Progress (continued)

#### 1107. Power Plant Structure

The prototype power plant structural design was started on May 26, 1966, by releasing approved design data diagrams as required by the Detail Work Plan. These design data diagrams established the design loads for the power plant structure for both the B-2707 (GE) and the B-2707 (P&WA).

#### 1108. Empennage

As a result of the choice of B-2707 model, structural studies of the horizontal stabilizer have been initiated in many areas. Location of the auxiliary drive system and the environmental control system have become major considerations in these studies. Structural support of the engines and of the elevon and its actuation system, in addition to fuel tank provisions, are other considerations.

Attachment of stabilizer to body is being studied to determine the most feasible attachment compatible with manufacturing requirements, weights and design requirements.

The vertical and ventral fins on model B-2707 are similar to previous models and the structural arrangements developed are therefore similar. Designs of body attachments, actuator supports, and rudder support structure are being developed.

The design and drawings of the composite stabilizer structure test component which is planned for hot and cold testing have been completed and released to Manufacturing.

Design and drawings have been prepared and released for fifty-nine additional honeycomb panels to be used in the allowables test program. Variations in detail design have been incorporated to evaluate their effect on allowables.

## 12. AIRFRAME SYSTEMS

### 1202. Environmental Control System (ECS)

#### (1) Compressor Development Program

The program for development studies and hardware testing of the cabin air boost compressor is proceeding on schedule. Coordination meetings were held on April 13 and 14 and May 26 and 27. The development unit configuration was fixed and design approval given on April 14. The design analysis and configuration report No. 66-0316(2) was received from AiResearch.

### III. Description of Technical Progress (continued)

#### 1202. Environmental Control System (ECS) (continued)

##### (2) System Optimization Studies

A trade study was completed on a system arrangement where the primary and secondary air to air heat exchangers is replaced by a fuel to air heat exchanger located in the fuel recirculation line. The study indicated that the installation would be simplified but an unacceptable system weight increase of approximately 600 pounds resulted.

Investigations of a modular packaging approach for the cooling units was continued. Studies to date indicate that airplane takeoff weight can be reduced by approximately 275 pounds.

(3) In accordance with the detailed work plan, the following has been accomplished:

(a) Flight deck air supply and exhaust requirements have been fixed. Air supply requirements are 33.2 lb/min. for ground operation and 26.6 lb/min. for operation during supersonic cruise.

(b) Release of drawings for Class I mockup has been initiated with the release of drawings of the boost compressor.

(c) Document D6A10064-7, "Environmental Control-Reliability Analysis" was completed and transmitted to F.A.A.

##### (4) Vendor Coordination

Updated technical proposals were requested from potential suppliers for the prototype airplane ECS equipment and are expected to be received the first week in June.

##### (5) F.A.A. Coordination

Discussions were held with Mr. L. Trenary on status of the system development. Boeing recommendations on the F.A.A.-sponsored cosmic radiation research program were presented. He was also informed of the decision to maintain installation space provisions for a radioactive debris filter and to develop the filter package in Phase III.

#### 1203. Hydraulic Systems

The 125 gpm hydraulic pump proposals have been received from American Brake Shoe, Bendix-Utica, Sundstrand, and Vickers. Source selections are scheduled for June 1.

The flight control master servo vendor proposals evaluation will be completed May 27. The vendor selected will complete a detail unit design by the end of Phase II-C.

The tubing and fitting test programs have been re-oriented to place greater emphasis on titanium alloy re-connectable fittings

### III. Description of Technical Progress (continued)

#### 1203. Hydraulic System (continued)

and 6Al-4V and 3Al-2.5V tubing. The use of 6Al-4V machined sleeves welded to 3Al-2.5V tubing is being investigated because 3Al-2.5V bar stock is not available.

In order to expedite the fitting and tubing fabrication test programs, 6Al-4V welded tubing has been ordered in lieu of seamless tubing. This tubing will be delivered June 23rd.

Because of excessive leakage, the second phase of the swivel seal test program was terminated at 19,000 cycles at 425°F. The excessive leakage was caused by worn high-pressure seals which had experienced 200,000 cycles at an average temperature of 400°F in the previous phase. This phase of the program is being revised to include a new swivel using piston type seals to alleviate the seal installation problem encountered on the first swivel. This program plan will be completed by mid-June.

The fluid loop pump test program has been reactivated with Dow Corning XF-10294 fluid in the system. This system has accumulated 269 hours with no problems. An identical system filled with Castrol B88BY-64 is scheduled to start running by early June. Completion dates are mid-August and mid-September, respectively.

The actuator environmental test program and analysis has been completed.

A second phase of the program has been initiated to obtain detailed information on the effect of rod seal leakage rates on seal temperature at null and with the actuator cycling. The data analysis completion date is mid-August.

#### 1204. Flight Control System

Preliminary block diagrams of the flight control system on the proposed configuration have been prepared and are being reviewed.

Preliminary procurement specifications for the wing sweep actuator and the wing sweep power control unit have been completed and released. Copies are being sent to prospective suppliers for cost quotations.

The flight controls and hydraulics subsystem specification (D6A10120-1) outline was completed. This specification replaces the hydraulic subsystem specification (D6-17854) and the automatic flight control subsystem specification (D6-17855). The inputs to this new specification are approximately half completed.

D6-18110-5

### III. Description of Technical Progress (continued)

#### 1204. Flight Control System (continued)

A tentative list was compiled of flight controls and hydraulics subsystem equipment required for dispatch and for flight continuation.

A preliminary equipment failure and human error analysis was completed for the wing sweep subsystem; directional control subsystem and speed brake subsystem. This comprises 20 percent of the failure analysis task for the flight controls subsystems.

A design coordination review of the Bertea horizontal stabilizer servo development indicated no desired changes in the program. Detail design is being completed and components are in manufacturing, with a few parts completed. Arrangements were made to incorporate instrumentation provisions.

#### 1205. Electrical Systems

##### 12052. ELECTRICAL POWER SYSTEMS

A proposal has been received from one vendor for a variable speed, constant frequency (VSCF) system meeting the revised system specification 10-61114. This specification defines components of either a 40 kva or 60 kva system capable of isolated or parallel operation with minimum frequency and voltage transients and high operating efficiency. The system has the capability of synchronized in-step operation even when isolated and can deliver significant amounts of windmilling power. Transfer of power between ground units and airplane generators occurs with no power interruption to loads. A second vendor's proposal is expected by June 1, 1966.

Developmental contracts have been awarded to General Electric Company and Lear Siegler, Inc. to develop prototype aircraft generators for the VSCF system. The G.E. contract is funded as part of the SST Phase IIC Program and the Lear Siegler contract is funded as a Boeing research item. The generator will be a variable speed, oil cooled and lubricated device with a system rating of 60 kva. Although the contract award has been delayed, the program is now being accelerated to compensate for the delay. The Lear Siegler generator features high voltage generation, 480 volts L-N, speed range of 9000 to 18,000 rpm, and carbon face magnetic seals. The General Electric generator features 160 volt L-N generation and a speed range of 10,000 to 20,000 rpm. It will require development of bearing and oil transfer seals. Both generators will contain non-resetting type disconnects and permanent magnet generators.

A trade study has been made to select the VSCF generator cooling oil system configuration from four choices:

- (1) Integrated accessory drive system (ADS) and generator oil circuit,

### III. Description of Technical Progress (continued)

#### 12052. ELECTRICAL POWER SYSTEMS (continued)

with common pumps and reservoirs

- (2) Generator pump mounted inside the ADS, but generator and ADS oil circuits isolated from each other
- (3) Generator oil pump mounted externally on and driven by the ADS with oil circuits isolated
- (4) Generator oil pump mounted within the generator housing, driven by gearing from the generator shaft, with the oil circuit isolated from that of the ADS.

Preliminary results indicate that configuration (3) is the best choice on the basis of technical confidence, system complexity, reliability, and maintainability.

Interest continues in a constant speed generating system as backup for the VSCF system. Based on the revised CS-CF generation system specification, 10-61115, two vendors have submitted proposals for generating systems of 40 and 60 kva capacity. The proposed systems feature the latest advances in generator design and solid state control circuitry. Based on the revised constant speed drive specification, 10-61117, one vendor submitted a proposal for an axial geared constant speed drive (AGD) in 40 and 60 kva rating. The AGD drive system features improved efficiency and reliability and lower operating cost. The system will provide precise frequency control through use of a frequency reference unit.

The power distribution and bus configuration, recently revised, is shown in Fig. 53. The system may be operated fully paralleled, split paralleled (two sets of paralleled generators), or isolated. Split parallel operation is considered normal. At the option of the crew, the system can be operated in parallel or in two independent halves, by operation of the synchronizing bus isolation breaker (SBIB). This is expected to allow realization of some of the advantages of both operating modes.

Parallel operation provides the following advantages:

- (a) Total electrical load divides equally among all generator systems.
- (b) Failure of one channel does not interrupt power to all loads.
- (c) Motor starting and peak load capability is better than with split or isolated operation.
- (d) Clearing of faults by thermal circuit breakers is faster than with split or isolated operation.

D6-18110-5

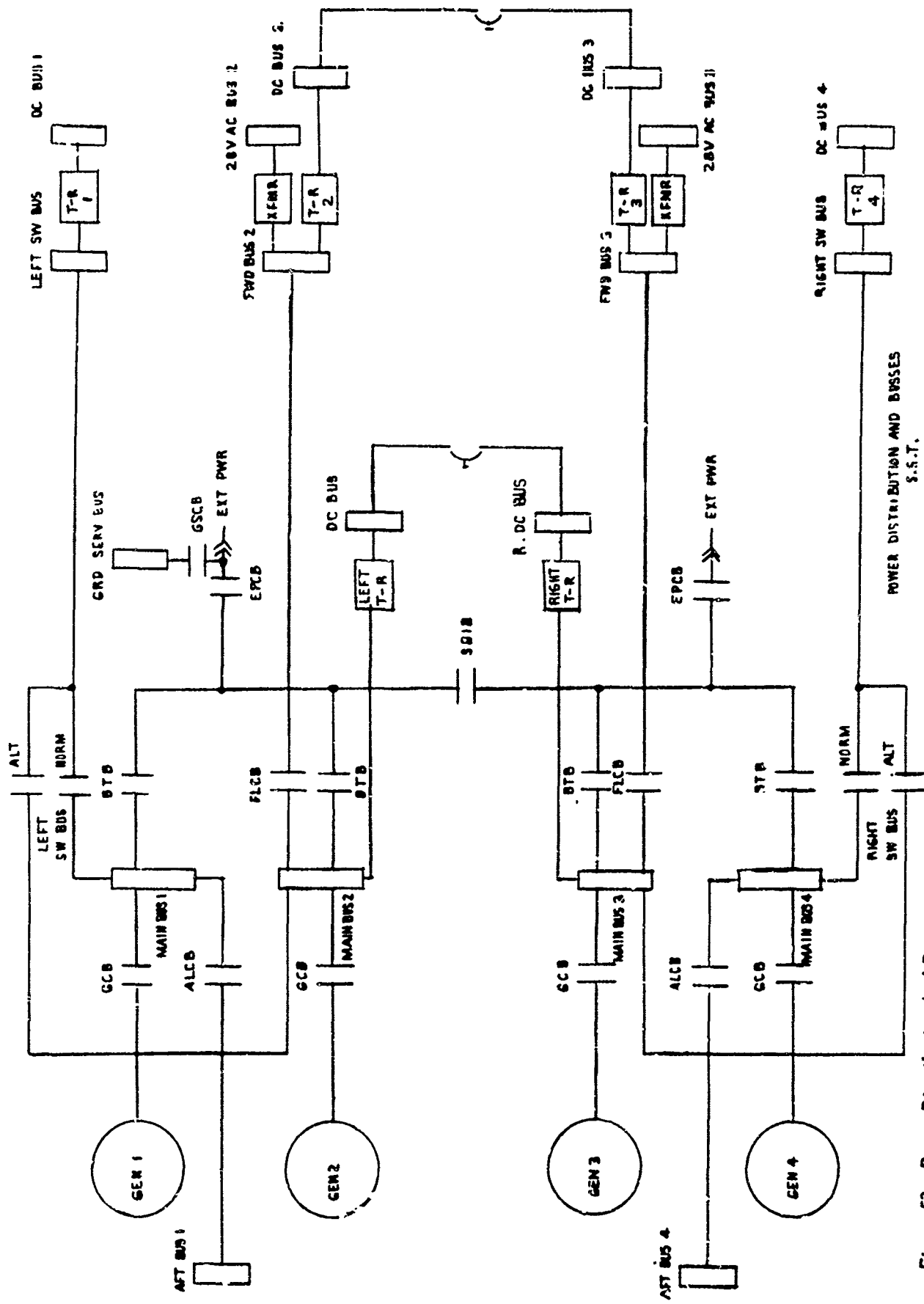


Figure 53. Power Distribution And Buses

D6-18110-5

### III. Description of Technical Progress (continued)

#### 12052. Electrical Power Systems (continued)

Split operation provides the following advantages:

- (a) A failure in one half does not propagate into or affect the functioning of the other half.
- (b) In systems where redundancy is provided to ensure continuous functioning, one branch is connected to each half.
- (c) Electrical and physical separation of the two halves is provided.

Two switchable aft busses (Generators 1 and 4) and two switchable forward busses (Generators 2 and 3) are provided. Also six 28 vdc busses are provided, four forward (28 vdc busses 1, 2, 3 and 4) and two in the mid section (right and left vdc busses). Redundant load systems are connected to different busses to ensure system operation. A typical example is shown in Fig. 54. Busses 1 and 2, or 3 and 4 may fail, but still there will be one fuel pump in each tank operating.

The standby power system consists of a battery, battery charger, and dc-to-ac inverter. It supplies electrical power for selected ground functions and emergency functions during flight in the event the main ac or dc source is inoperative. Two vendor proposals have been submitted in response to specification 60A10006 and will be reviewed. Information from the proposals will be used to complete trade studies, update the specification, and finalize the standby power system configuration.

An electrical control panel configuration for the VSCF generating system has been designed. The detailed arrangement of the panel, Figs. 55 and 56, has been made to meet the electrical system and human factors requirements.

The electrical control system is an automatic system with a manual override, designed to simplify and reduce the work load of the flight engineer. The generating system controls on the panel are separated from the load controls. The pattern concept is maintained throughout the panel. An automatic transfer onto and off of ground power is provided through one of the mode selectors. During transfer airplane power is momentarily paralleled with ground power so that supply to airplane loads will not be interrupted. The bus tie breakers are controlled during flight by the second mode selector switch, which selects the generating system operating configuration: parallel, split parallel, or isolated. Individual bus tie breaker control is provided to override the automatic system in an abnormal operation of the system. The required metering circuits and a check-out system are provided.

A trade study to evaluate various techniques for protecting heavy load circuits against damage due to overload or fault currents has been initiated. Preliminary results indicate solid state control offers

D6-18110-5

# FUEL BOOST PUMPS

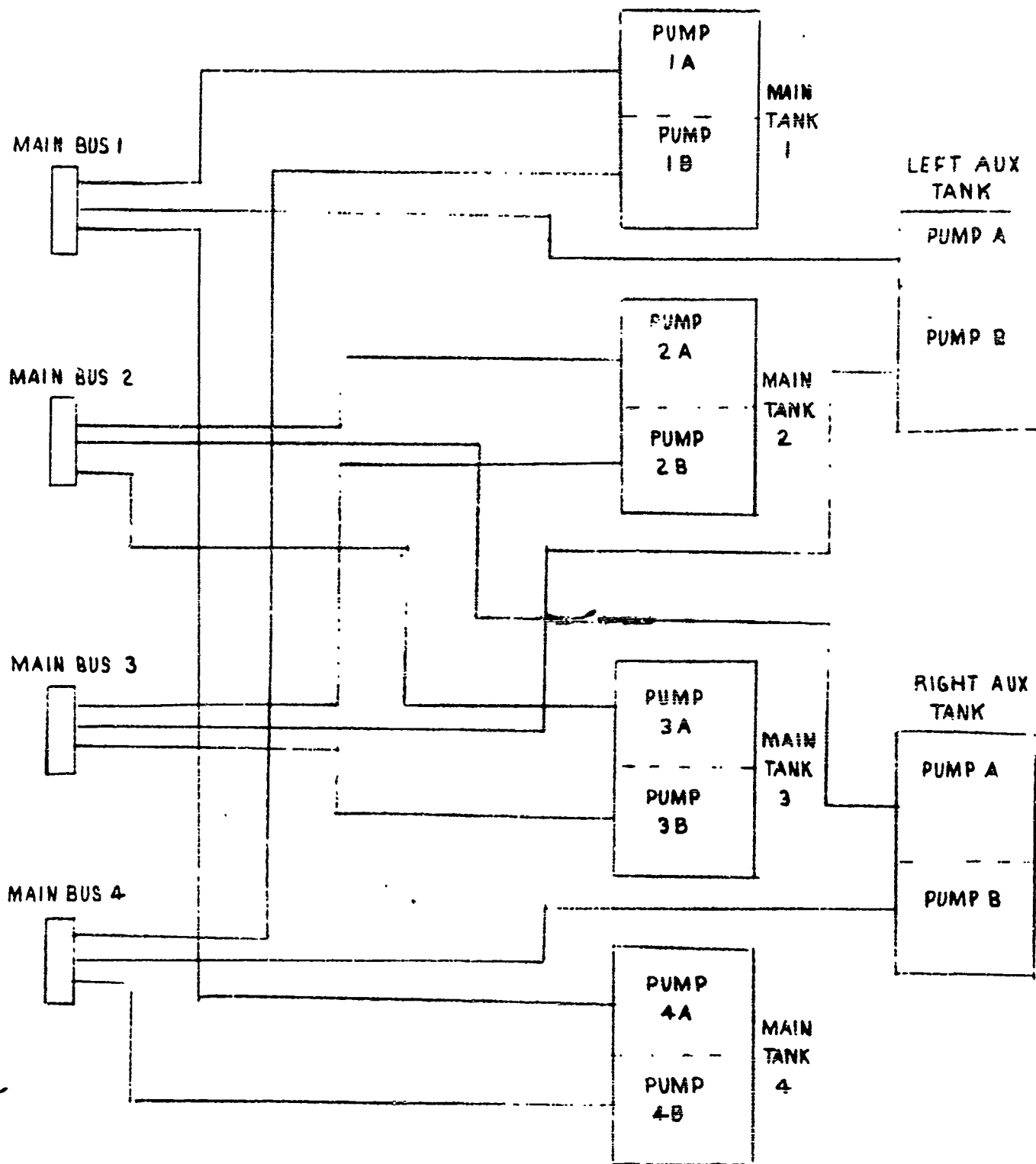


Figure 54. Fuel Pump Power Source Schematic

D6-18110-5

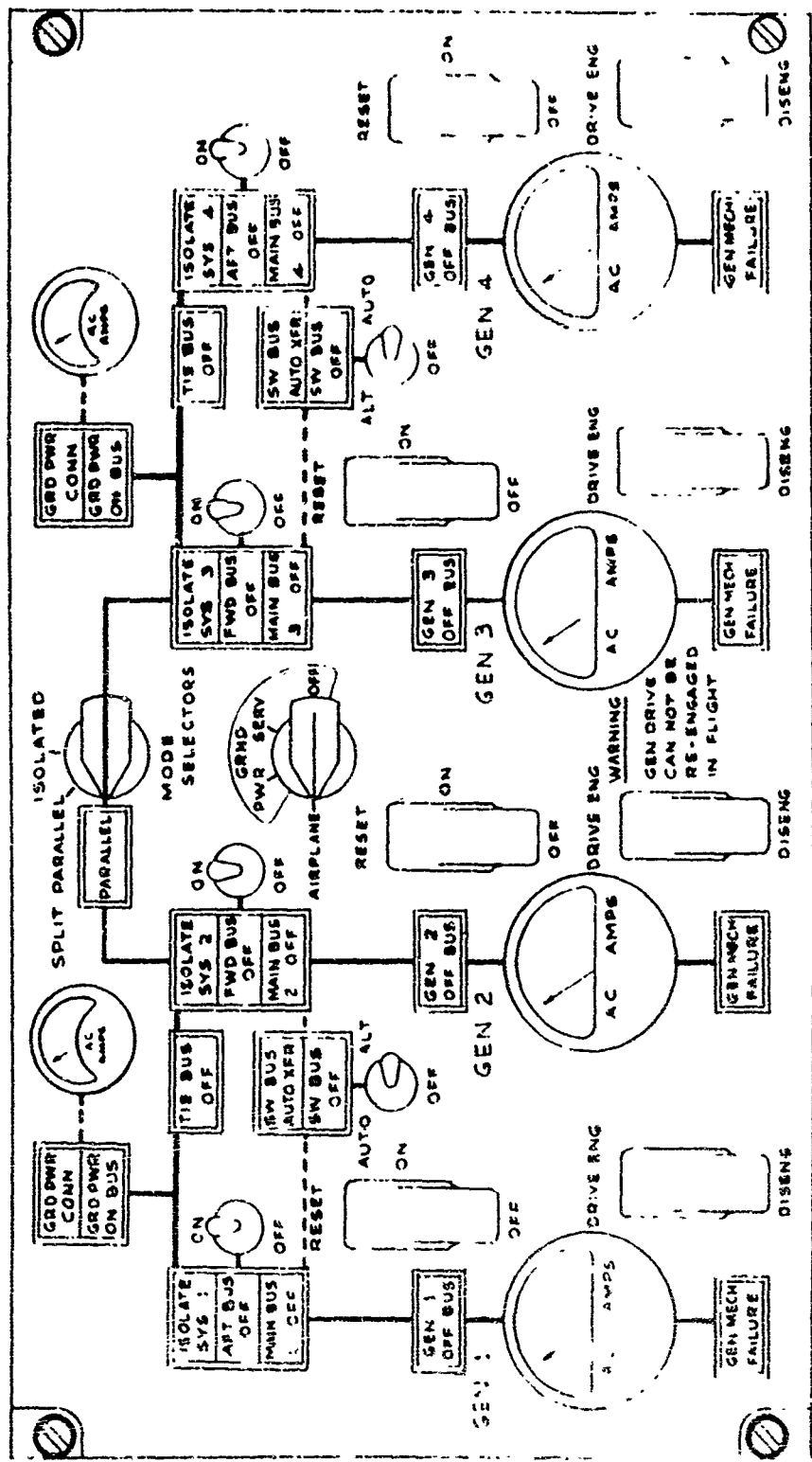


Figure 55. Electrical Panel Diagram

D6-18110-5

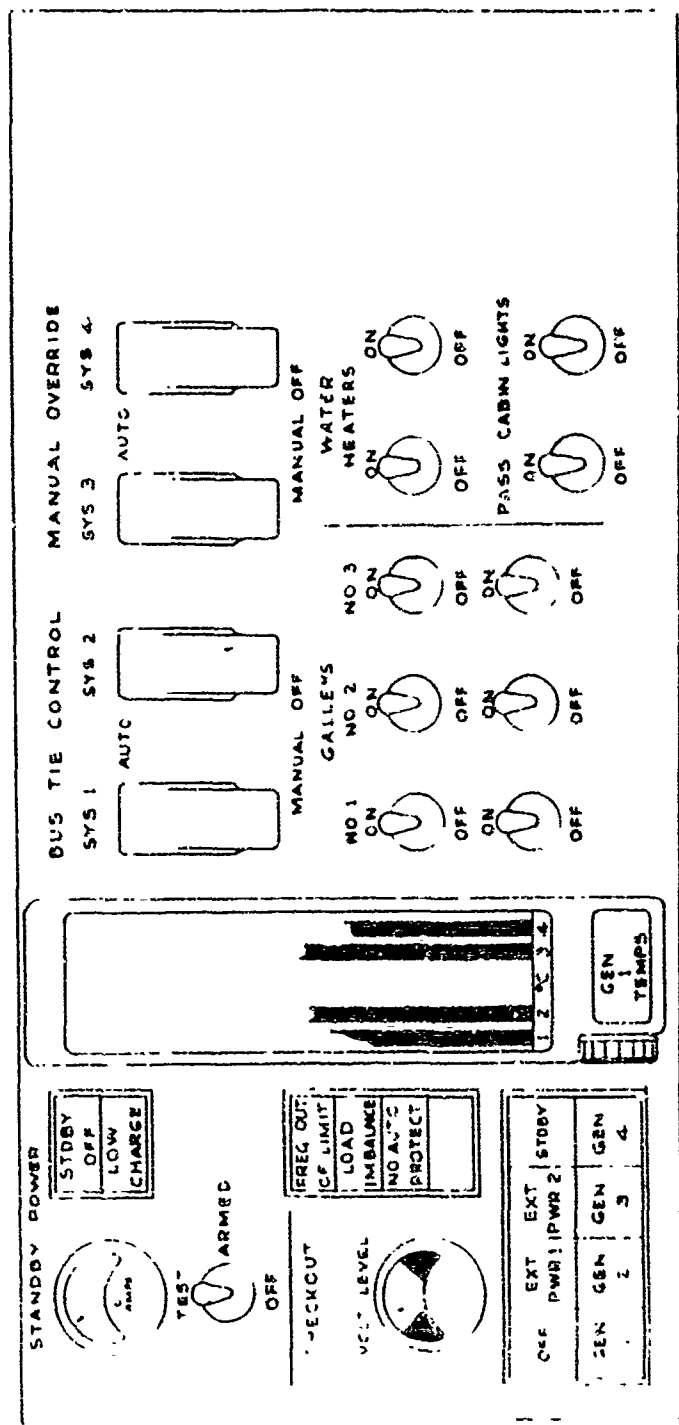


Figure 56. Electrical Panel Diagram

D6-18110-5

### III. Description of Technical Progress (continued)

#### 12052. Electrical Power Systems (continued)

significant advantages in performance, reliability, maintainability, and weight reduction. Availability, however, requires additional development. Electromechanical devices employing direct line current sensing offer better protection than conventional methods, are more economical than solid state control, but exhibit low reliability, and require more maintenance. Use of differential current sensing appears to be inadequate, particularly for 3-phase loads. Final recommendations await completion of this study.

Document D6-16328, "Electrical Requirements for Items of Equipment Installed in the Model 733 Airplane", was revised on May 2. Revisions included addition of component wiring, grounding, and bonding information. The maximum duration of undervoltage was reduced to five seconds. Insulation resistance, leakage current, and corona requirements and product assurance tests were added. The limits for abnormal ac voltage transients are being determined, with completion scheduled for August 1.

#### 12053. AUXILIARY ELECTRICAL SYSTEMS

Proposals in response to the release of 10-61118, Remote Circuit Breaker Specification, were received during the latter part of May. Proposal evaluation will be made during the first part of June.

Electrically driven fuel pumps make up approximately one-half of the electrical load on the power system during some part of the flight profile. Preliminary review of available information indicates that the fuel pumping loads and consequent generator capacity allocated to pumping can be reduced if a variable speed pumping system is developed. The variable speed pumping characteristic would present low electrical demand during a low flow condition as opposed to a constant high electrical demand for all flow conditions. A study is planned to determine the feasibility of this concept. Upon completion of the study, a follow-on program will be developed if justified.

In line with electrical load reduction studies, the estimated input power to the environmental control system ground fans has been increased and trade studies are being instituted to replace the electrically driven fans with turbofans, in part or total, for a reduction in the generating system capacity.

#### 12054. ELECTRICAL POWER UTILITY AND UTILIZATION EQUIPMENT REQUIREMENTS

Progress on activities associated with new equipment items, previously reported, is summarized as follows:

(a) Procurement specification 10-60981, "Multichannel Control and Indicating System", was released to industry with a request for

D6-18110-5

### III. Description of Technical Progress (continued)

#### 12054. Electrical Power Utility and Utilization Equipment Requirements (continued)

proposals. Proposals are expected to be received in the first half of June 1966.

(b) The potential reliability of solid state proximity switches being far greater than mechanical switches, are proposed for extensive use as position indicators in both pressurized and unpressurized zones. A preliminary procurement specification, 60A10001, for a proximity switch compatible with the natural temperature environment of the SST, has been released and to date five vendor proposals have been received.

One proposal appears very promising. The sensor utilizes the variable reluctance principle as now used on the 737 airplane but is temperature compensated to permit satisfactory operation at 500°F ambient. Cost and complexity are high, however, and additional vendor proposals are being requested.

(c) A preliminary trade study to evaluate cost, reliability, weight, and maintainability advantages of solid state discrete components vs. solid state integrated circuits vs. miniature 1/2 size crystal can relays has been completed. The results show relays have a very slight advantage over integrated circuitry. Because of the very large potential improvement in reliability and cost of integrated circuits, there is a good possibility that the advantages of this type of solid state device may be combined with the best features of relays to perform all logic and medium level switching functions of landing gear and flight control systems.

#### 12056. WIRING AND TERMINATIONS

Design layouts to provide data for the installation of major wire raceways are in work. Present design provides for a floor raceway through the center aisle, from front to rear, accessible from the passenger compartment. In addition, two raceways are provided in the ceiling for the lighting and passenger accommodations. Wiring will be installed into the raceways using plug-to-plug interwiring concept. Where practical and to reduce volume and weight, ribbon cables of standard stranded conductors will be utilized. Environmental constraints, electro-magnetic interference, and maintainability have been considered and will be reflected in the final raceway design.

Parameters have been established and a test program started on a simulated installation of electrical wires across the wing pivot. The test results will define the configuration of the wire routing across the wing pivot. To be included in the test will be various types of flexible conduit, rope lay cables, and high temperature clamping devices. The test will be run to simulate temperature variation and wing sweep. Results of these tests will also be used for the definition of the wiring concept on landing gear and other movable portions of the aircraft.

### III. Description of Technical Progress (continued)

#### 12056. Wiring and Terminations (continued)

A trade study of copper versus aluminum wire for galley busses and forward power feeders disclosed that considerable weight will be saved by use of the aluminum wires. Proportional weight savings may be gained by use of aluminum wire in sizes 8 through 4/0 for other installations within the pressurized section. The weight savings may be gained without degradation to safety, performance, reliability, or maintainability.

#### 12057. ELECTRICAL EQUIPMENT - General

A mockup of rack-mounted components is required for determining wire routing and general clearances. Although the electrical and electronic equipment is planned for rack mounting in forward, central, and aft locations, a detailed floor mockup of a representative section of the forward rack is planned. This will show unit arrangement, plan of wiring including interface (junction) box concept, and general access. Drawings have been released and the rack mockup is scheduled for completion by mid-June.

#### 1206. Accessory Drive System (ADS)

##### (1) Development Program

Coordination meetings were held at Hamilton-Standard on April 21 and 22 and Sundstrand on April 25 and 26. Both contractors were directed to proceed with the design. Mr. R. Novotny of FAA participated in these reviews.

Developmental testing has been conducted by Hamilton-Standard to demonstrate the shaft oil scavenge concept and the capability of a lube pump to deliver sufficient head when operated with an unpressurized gearbox.

Both subcontractors expect to meet the initial demonstration run dates in late September and early October.

In accordance with the detail work plan, Class I mockup drawings of the ADS and air turbine-starter were released.

##### (2) Gas Turbine Starter

Investigations of the gas turbine were continued. A technical proposal (Gt-7720-4, Rev. 1) was received from AiResearch.

#### 1207. Automatic Flight Controls

The specification control drawing (SCD) for the AFCS was submitted to the vendors on April 25, 1966. A revision "A" to the SCD covering Stability Augmentation System requirements was released on

### III. Description of Technical Progress (continued)

#### 1207. Automatic Flight Controls (continued)

April 29, 1966 and submitted to the vendors. A vendor briefing (question/answer session) was held May 11, 1966. Vendors proposals are due 6 June 1966.

The AFCS preliminary block diagrams (65A10140) have been released and forwarded to the FAA May 13. The diagrams will be revised during the course of design.

The preliminary reliability analysis document (D6A10064-4) was released and forwarded to the FAA May 13.

The SAS Authority Requirements determination detail work plan Item 2170 will be completed in early July to be compatible with the new configuration.

#### 1208. Flight Deck Installations and Systems

The Phase II-C development Class II mockup interior furnishings and equipment releases are 95 percent complete and on schedule. The structural frames for the captain's, first officer's and flight engineer's seats are on order. Delivery of the first seat is scheduled for 5-21-66 and the other two for 6-1-66. Since some rework of the seat structure plus upholstery is to be done at Boeing, any delay by the vendor in meeting these dates will have an impact on the mockup schedule.

#### 12081. INSTRUMENTATION AND CONTROL ARRANGEMENTS AND DISPLAYS

Updating of pilot's copilot's and flight engineer's instrument and control modules in accordance with requirements of B-2707 configuration is in progress. The primary effort is to ensure that the latest information is reflected in the flight deck mockup, scheduled for air-line and FAA review on June 23, 1966.

#### 12083. RAIN REMOVAL SYSTEMS

A design investigation of the SST rain removal system was initiated per event 2125 of the detailed work plan. This investigation includes a review of the present design concept for meeting rain removal requirements for the takeoff and approach configuration windshield and the cruise fairing windows.

#### 12084. PITOT-STATIC SENSORS

A preliminary specification for pitot and static pressure sensors (10-61079) has been prepared and released to equipment manufacturers. The specification covers a number of different types of pitot and static pressure sensors being considered for the SST, including compensated nose-mounted pitot-static probes, body mounted pitot-static probes, and body mounted pitot probes.

D6-18110-5

### III. Description of Technical Progress (continued)

#### 12084. Pitot-Static Sensors (continued)

A meeting was held with Aero Research to discuss their work in the area of air data sensors. Specific items covered included reliability and design of anti-icing elements of external sensors, design requirements for compensated pitot-static probes, and pitot-static sensing installations of operational supersonic aircraft.

#### 12085. AIRPLANE SURVIVABILITY/CREW ESCAPE SYSTEM STUDY

The study has been completed and a report is in rough draft. The document is scheduled for Boeing management review starting in early June and completion by mid-June.

#### Flight Simulation Vision Studies

The cruise vision portion of these studies has been completed. Data is being analyzed, and a final report is in preparation.

The approach and landing under VFR conditions portion of the studies will be in operation in early June. The series will employ a landing field model with a scale factor of 500:1 (approximately 90 feet long, including approach).

#### Flight Tests Using Onboard TV as a Vision Aid

Test flights have been made with a closed circuit TV system installed in a 707 airplane. Results to date in the cruise phase are not conclusive, but as an aid in approach, landing, and taxiing the method shows promise.

#### Forebody Mockup Environment

Three ways of displaying scenes in front of the mockup cab for simulation of flight vision have been evaluated. Work is proceeding using the selected method.

#### 1209. Communications

Preliminary proposals for the VHF antenna were received during May from interested companies.

The preliminary procurement specification 10-60991, HF notch antenna coupler, has been revised in preparation for requesting pricing information from vendors.

A report was issued describing the proposed electrical configuration for the Boeing-designed VHF communication antenna.

Radiation patterns were made on a ventral fin HF antenna. A report describing the progress to date in the development of an HF antenna system is being prepared and will soon be released.

D6-18110-5

### III. Description of Technical Progress (continued)

#### 1209. Communications (continued)

A test report describing an experimental satellite communications antenna has been released.

A trade study has been performed on the interphone system. Based on this trade study, the results of the evaluation of the breadboard mockup of the solid state switching system, and evaluation of vendor equipment, the decision was made to design the interphone system using remote switching concepts.

#### 1210. Navigation

A meeting with Autonetics Division of North American during April and one with RCA in May were held for the purpose of reviewing their respective programs in the field of radar design. Autonetics has designed, built, and tested a microminiaturized K-band radar system for military application which was reported to have demonstrated a significant increase in operational reliability over today's equipment. Autonetics suggested that the basic design of their system could be adapted to meet the requirements of the SST weather radar.

Information received from RCA indicates that an increase in performance and reliability compatible with SST weather objectives is possible with new X-band and C-band equipment designs.

Meteorological activities in support of the weather radar studies have included a visit to the National Severe Storms Laboratory (NSSL), Norman, Oklahoma. Information on the nature, distribution, and radar properties of severe storms was obtained. This information is being integrated into the overall meteorological model and the dependent analysis of the radar system requirements.

A design progress review meeting was held at the Brunswick Corporation, Marion, Virginia, on April 19 and 20, 1966. The sub-contracted nose radome program schedule is proceeding satisfactorily. A technical problem of a higher than expected loss tangent in the material has arisen. The cause of and the solution for this problem are being investigated.

A report was released updating published data on all dielectrics testing to date.

Technical problems in the lightning protection system and in the basic radome material were identified. Action to obtain material for further investigation of these problems was initiated.

### III. Description of Technical Progress (continued)

#### 1210. Navigation (continued)

Brunswick's electrical qualification and acceptance test procedure release for the Boeing SST full-scale radome assemblies was reviewed.

Radiation patterns were made of a horizontal loop antenna examined as a possible retractable localizer antenna with the antenna installed on (1) top centerline of airplane and (2) bottom centerline of airplane.

Radiation patterns were made of a nose gear-mounted, glide slope antenna. A slot array, glide slope antenna system using a hybrid ring for sum and difference patterns is currently being examined.

Proposals for SST antennas have been received from interested companies.

A preliminary failure mode and effect analysis and trade study has been prepared on the radic altimeter and VOR/localizer.

Responses to the RFP on Boeing specification 10-60975 were due toward the end of the month. The inertial navigation specification (10-60975) was revised to specify that the basic inertial navigation system, (i.e. control, display, navigation and battery units) conform to the packaging and interunit wiring requirements of the proposed ARINC characteristic number 561 which is being generated by the AEEC subcommittee on inertial navigation. (Boeing corresponds with, and supports this subcommittee as required).

The following preliminary procurement specifications have been released to obtain cost and technical data from suppliers:

10-60972 Radar, Weather and Ground Mapping

10-61069 Flight Data Recorder.

#### 1211. Electronics - General

Lightning strike tests were conducted at Joslyn Electronic Systems, Santa Barbara, to investigate the puncture resistance of several types of honeycomb panels. A titanium panel was easily punctured while a titanium panel with a polyimide core could not be punctured with 400-coulomb discharges. Tests were also made to investigate methods of protecting a polyimide-fiberglass panel which has a fiberglass outer skin and a titanium inner skin. The tests indicated that

### III. Description of Technical Progress (continued)

#### 1211. Electronics - General (continued)

the panel could be completely protected with an aluminum wire mesh tape. A titanium tape was unsuccessful and an aluminum tape was partially successful in protecting the panel. A test report will be submitted by Joslyn on June 1.

Preparation of a specification for the external type of static dischargers was initiated. A passive rod and blade-type discharger will be used in this specification for the tail surfaces and the wing tips.

A state-of-the-art report on clear air turbulence was completed. In-flight detection of clear air turbulence was demonstrated using the Boeing-developed VHF system.

A summary of the existing government and industry sponsored programs concerned with collision avoidance systems was prepared.

Wire coupling tests were accomplished in a model 727 fuselage, built for structural test purposes. The data obtained demonstrated very favorable correlation with laboratory data obtained with aluminum sheets. Confidence was established that valid EMC design data could, in fact, be generated in the laboratory using titanium sheets.

Cost and technical data requested from suppliers for 10-60976, aircraft integrated data system (AIDS), are expected on June 9th.

Layouts detailing electronic racks were released for mockup.

#### 1212. Fire Detection and Protection

##### 12121. FIRE EXTINGUISHING SYSTEM

The design and test requirements for the fire extinguishing system have been established and documented. The bottle assembly size and shape and amount of extinguishing agent required have been determined as well as the configuration of the gage and pressure switch, the discharge valve, and the swing check valve. The environmental requirements for the system have also been defined.

##### 12122. FIRE DETECTION SYSTEM

Proposals in response to Revision "A" of 10-61291, Fire Detection System Specification, were received during the first part of May.

A trade study was initiated during the last part of April on seven fire detection system concepts.

### III. Description of Technical Progress (continued)

#### 12122. Fire Detection System (continued)

Concept I is a heat sensitive, continuous dual element, shrouded system. This system requires a signal from each element before an alarm is actuated in the cockpit. Concept II is the same as Concept I except a meter readout of fire zone temperature has been added.

Concept III is a flame sensitive, spectral radiation type system. This system senses radiation from a flame and through appropriate controls actuates an alarm in the cockpit.

Concept IV is a flame sensitive television system. This system senses a fire by the presence of light and actuates an alarm in the cockpit. In addition this system will allow fire zone surveillance by the flight crew.

Concept V is a combination system using Concepts I and III. This concept is being evaluated on the basis that only the flame sensitive system, Concept III, has priority in reporting a fire.

Concept VI is a heat sensitive, continuous single element, shrouded system. This system receives a signal from the element when the element is heated and actuates the alarm in the cockpit.

Concept VII is the same as Concept VI except the shroud has been removed.

These seven concepts are being evaluated against safety, performance, and reliability criteria.

#### 1213. Passenger and Cargo Provisions

##### 12130. PASSENGER AND CARGO PROVISIONS, GENERAL

Items which are in the process of being detailed and/or installed in the full sized SST mockup include the following:

Air Conditioning System

Attendant's Stations

Class Dividers

Coat Closets

Cabin Lighting

Emergency Equipment

Lights, signs, extinguishers, life raft containers escape slide stowage, first aid kits

D6-18110-5

III. Description of Technical Progress (continued)

12130. Passenger and Cargo Provisions, General (continued)

Galleys

Conventional, dispersed and overhead track carrier service

In-flight entertainment

Television sets installed in seat backs

Overhead television and cinema

Taped music

Lavatories

Linings

Magazine Racks

Passenger entry and service doors

Passenger Seats

9 triples of "SST Concept"

Balance "Conventional"

Passenger Services for Seats

SST Seats - Reading lights, oxygen masks, service switches

Conventional Seats - Standard overhead passenger service units

Rear Cargo Compartment

Windows

Consists of a 5 opening module arrangement - 8-5/8 diameter window opening with a reveal design which permits smaller openings

12131. OXYGEN SYSTEM

Preliminary specification 60A10003 Pressure Breathing Demand Oxygen Mask and miniature Regulator System was released.

12133. PASSENGER WATER SYSTEMS

Preliminary specifications, 60A10022 Toilet, Flushing and 60A10023, Indicator System, Water Quantity were released.

The water system diagram LOPA-733-1276 was released.

12135. PASSENGER FURNISHINGS AND EQUIPMENT

A study was initiated on a food service system based on the principle of separating food tray items into hot, dry, and cold categories. The concept affects both galley arrangement and food

### III. Description of Technical Progress (continued)

#### 12135. Passenger Furnishings and Equipment (continued)

tray configurations and reduces space and refrigeration requirements in the galley. Study models were constructed. The result of this arrangement is a galley depth which enables aisle loading of a unitized service package solving the problem of (1) over-the-wing loading and (2) the proper spacing of the galleys, giving each stewardess "area" responsibility.

A passenger seat has been designed and mocked up based on the following concepts:

- A maintenance of comfort appropriate to the SST's projected 2-1/2 hours flight time.
- A reflection of the progressive trends in passenger comfort by a seat design capable of individualizing itself to each successive passenger, no matter what his dimensions.
- A seat of substantially reduced cross section profile from existing aircraft seats to minimize weight and provide more passenger room at standard seat pitches.
- The inclusion of passenger service units (emergency oxygen, reading lights, convenience table, literature pocket, individual television and breakover) towards additional passenger comfort.

#### 12136. CARGO PROVISIONS

A separate lower lobe mockup section is being constructed to demonstrate a preloaded container system. A feature of the installation is the integral hoisting and traversing of the containerized load.

### 13. PROPULSION SYSTEMS

#### 1300. Propulsion System General

##### 13002. ENGINE MOCKUP

On May 12 and 13, 1966, a meeting was held with GE at their Evendale plant for the purpose of defining the mockup engine. In preparation for the meeting Boeing prepared 10 layouts, during this reporting time period, that defined the mockup requirements. These layouts were used during the meeting to establish the configuration for the September 1, 1966, demonstration mockup at Boeing. Agreement was reached and the engine mockup configuration was settled.

On May 17 and 18, 1966, a meeting was held with Pratt & Whitney at their Florida research center to define the P&WA mockup engine. During this reporting time period Boeing prepared 11 layouts defining the mockup engine requirements. These layouts were used during the meeting to establish the configuration of the P&WA engine for the September 1, 1966, demonstration mockup. As a result of the meeting,

III. Description of Technical Progress (continued)

13002. Engine Mockup (continued)

agreement was reached on the definition of the mockup engine configuration.

On May 18, 1966, work was begun on details of the engine mockup as scheduled in the Detail Work Plan.

13003. POD SHAPE AND LOCATION

A tentative pod shape was selected for the P&WA and GE engines as scheduled in the Detail Work Plan. Thirteen layouts were made during this reporting time period as part of the development effort on the tentative pod shape for the B-2707 (GE) and B-2707 (P&WA).

1301. Performance (Installed)

Additional preliminary engine performance data have been received from General Electric and Pratt & Whitney. The following table summarizes the significant performance differences between the engines under study. All percent changes shown are referenced to the basic GE4/J5G and JTF17A-20B engines.

	<u>GE4/J5 A/B Turbojet</u>			
	GE4/J5G	GE4/J5 St	GE4/J5 Study P <sub>1</sub>	GE4/J5 Study P <sub>2</sub>
Static Airflow lbs/scc	475	520	600	600
Takeoff Thrust	---	+8%	+15%	+21%
Transonic Thrust	---	+4%	+ 9%	+17%
Supersonic Airflow	---	0%	0%	+10%
Supersonic Thrust	---	0%	0%	+ 5%
Weight	---	+6%	+16.5%	+16.5%
	Basic	Increased RPM	Increased RPM & Compression	Increased RPM & Compression

III. Description of Technical Progress (continued)

1301. Performance (Installed) (continued)

<u>P&amp;WA JTF 17A-20B C/E Turbofan</u>				
	JTF17A-20B	Study A	Study B	Study C
Static Airflow lb./sec	650	663	687	687
Takeoff Thrust	---	+3%	+7%	+7%
Transonic Thrust	---	+3%	+6%	+6%
Supersonic Airflow	---	0%	0%	+8%
Supersonic Thrust	---	0%	0%	+8%
Weight	---	+1%	+5%	+3.5%
	Basic	Increased RPM	Increased RPM & Variable Nozzle	Increased RPM & Resized Nozzle

The General Electric GE4/J5G, N<sub>1</sub> and P<sub>1</sub> engines and the Pratt & Whitney JTF17A-20B Study C engines were evaluated for airplane performance and noise characteristics. These results are presented in Sec. 10021. Range differences between engines studied are small. Noise reductions are potentially available in the study engines having increased takeoff airflow. These performance and noise results have been coordinated with each engine manufacturer. Cycle modifications that would improve the engine-airplane matching characteristics for the study engines have been requested from each engine manufacturer.

1302. Air Induction System

(1) Inlet Test and Analysis

(a) One-fifth Scale Model Testing

Boundary layer bleed and vortex generator locations have been determined for the smooth, fixed geometry Mach 2.6 centerbody. The inlet operating recovery (2-percent supercritical) is 89.5 percent with 6.5 percent boundary layer bleed. The corresponding distortion is 5.3 percent NDI or 10 percent  $\frac{P_{T_{max}} - P_{T_{min}}}{P_{T_{ave}}}$ .

Tests were run with two off-design centerbodies (M = 1.8 and 2.2) using the boundary layer bleed and vortex generator locations selected for the Mach 2.6 design case. The critical operation data for all three centerbodies are shown in Fig. 57. The distortion versus supercritical margin data for the Mach 2.6 case are shown in Fig. 58.

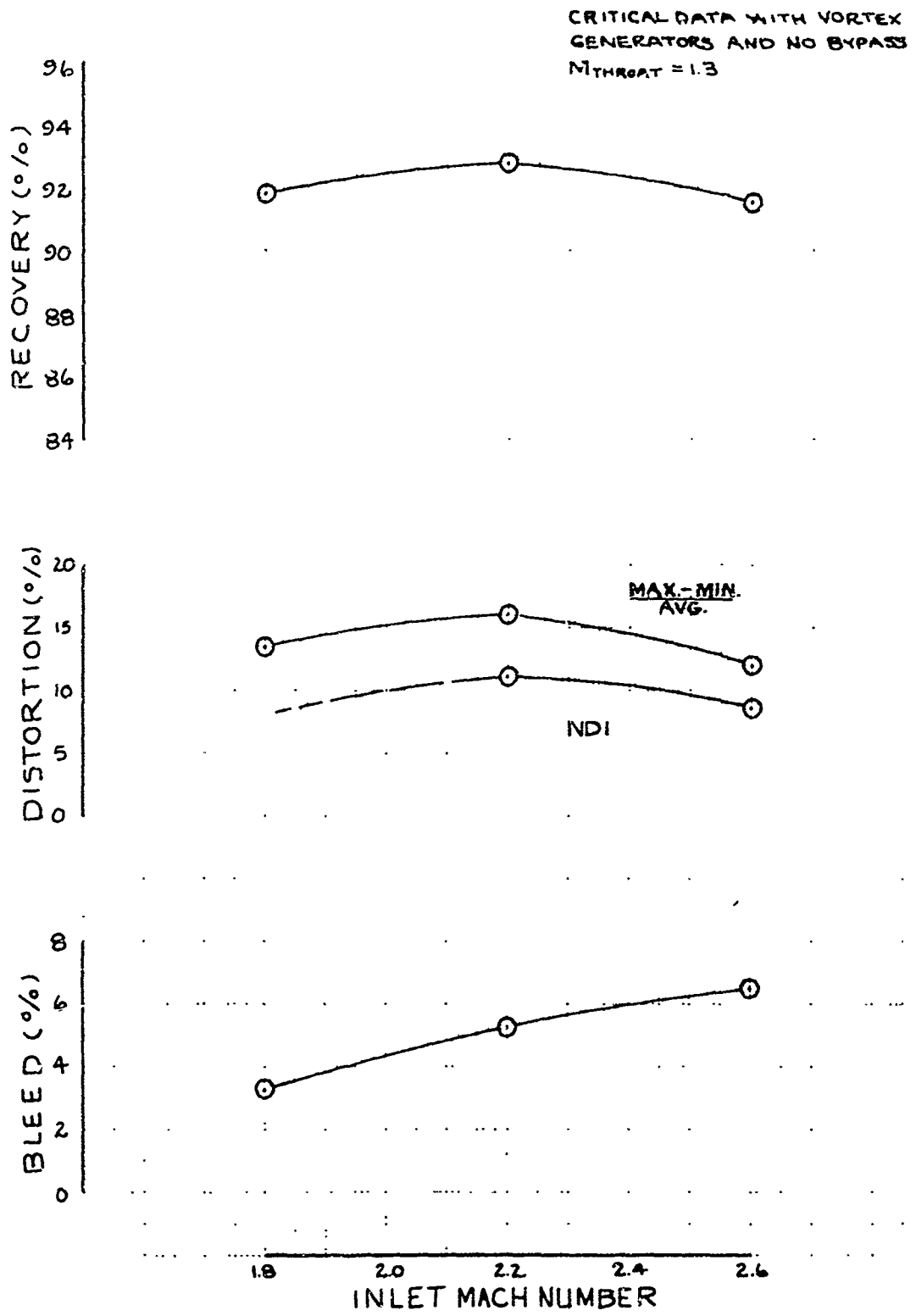


Figure 57. Inlet Performance, One-Fifth-Scale Inlet

D6-18110-5

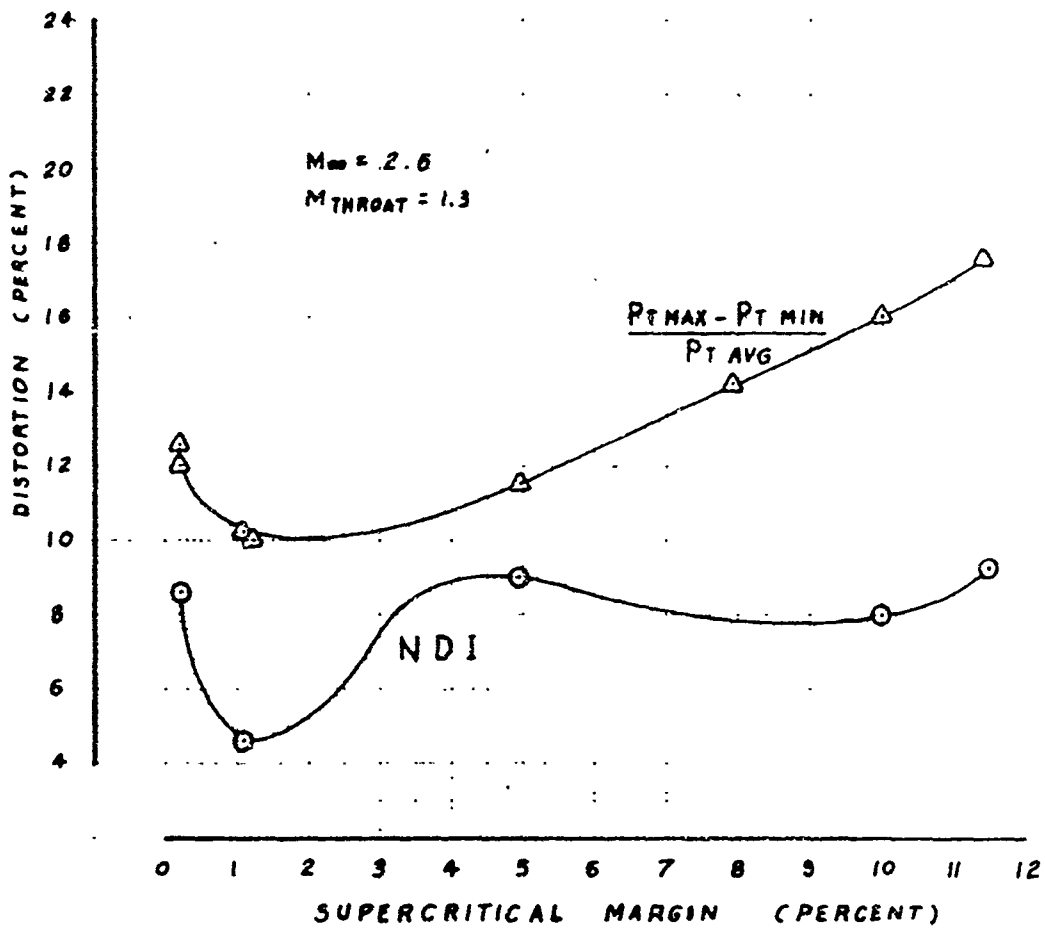


Figure 58. One-Fifth Scale Inlet, Distortion Data

D6-18110-5

### III. Description of Technical Progress (continued)

#### 1302. Air Induction System (continued)

Testing is underway to determine the effects of centerbody circumferential surface irregularities formed by the overlapping leaf segments.

##### (b) One-tenth Scale Low-Speed Testing

One-tenth scale tests are being conducted to verify satisfactory low-speed inlet operation on the B-2707 airplane configuration. These tests are also being performed to check out the takeoff door system design prior to starting the 1/3-scale low-speed tests with an operating engine (J85). The first runs have shown satisfactory model operation with expected inlet recoveries and distortions. Additional testing is to be done during June to map the operating envelope of the 1/3-scale test.

##### (c) One-third Scale Model Testing

The model design for the 1/3-scale test is nearly completed. The general arrangement of the engine, inlet, wing, and nozzle exhaust in the 9 by 9 foot test section of the Boeing low-speed wind tunnel is shown in the pictures of the 1/10-scale mockup (Fig. 59). Testing is scheduled in late July.

##### (d) Inlet Flow Field Testing

The inlet flow field environment for the B-2707 configuration was measured experimentally in the 4 by 4 foot BSWT during May. The inlet local Mach number and flow direction were obtained with a conical probe flow field rake. The boundary layer heights at each inlet were determined with two boundary layer rakes. Figure 60 shows the rakes installed on the model. The local inlet flow conditions were measured over a large range of angles of attack, angles of yaw, and freestream Mach number. Test results are shown in Figs. 61 and 62. The local Mach number and flow angles are very uniform for both inboard and outboard inlets. With the inlets located far aft on the wing for this configuration, the local inlet Mach No. is higher than on previous configurations. Studies are being made to determine the wing contour changes required to achieve a lower inlet Mach number.

(e) Figure 63 shows the schedule of various propulsion testing through August 1966.

#### (2) Analysis, Design, and Test of Engine-Size Inlets

##### (a) Full-Scale Test Hardware

The assembly of the structural test centerbody is now complete. Figures 64 and 65 are photographs of the assembly. The assembly was demonstrated through several actuation cycles to General Maxwell during his visit to Boeing on May 16, 1966.

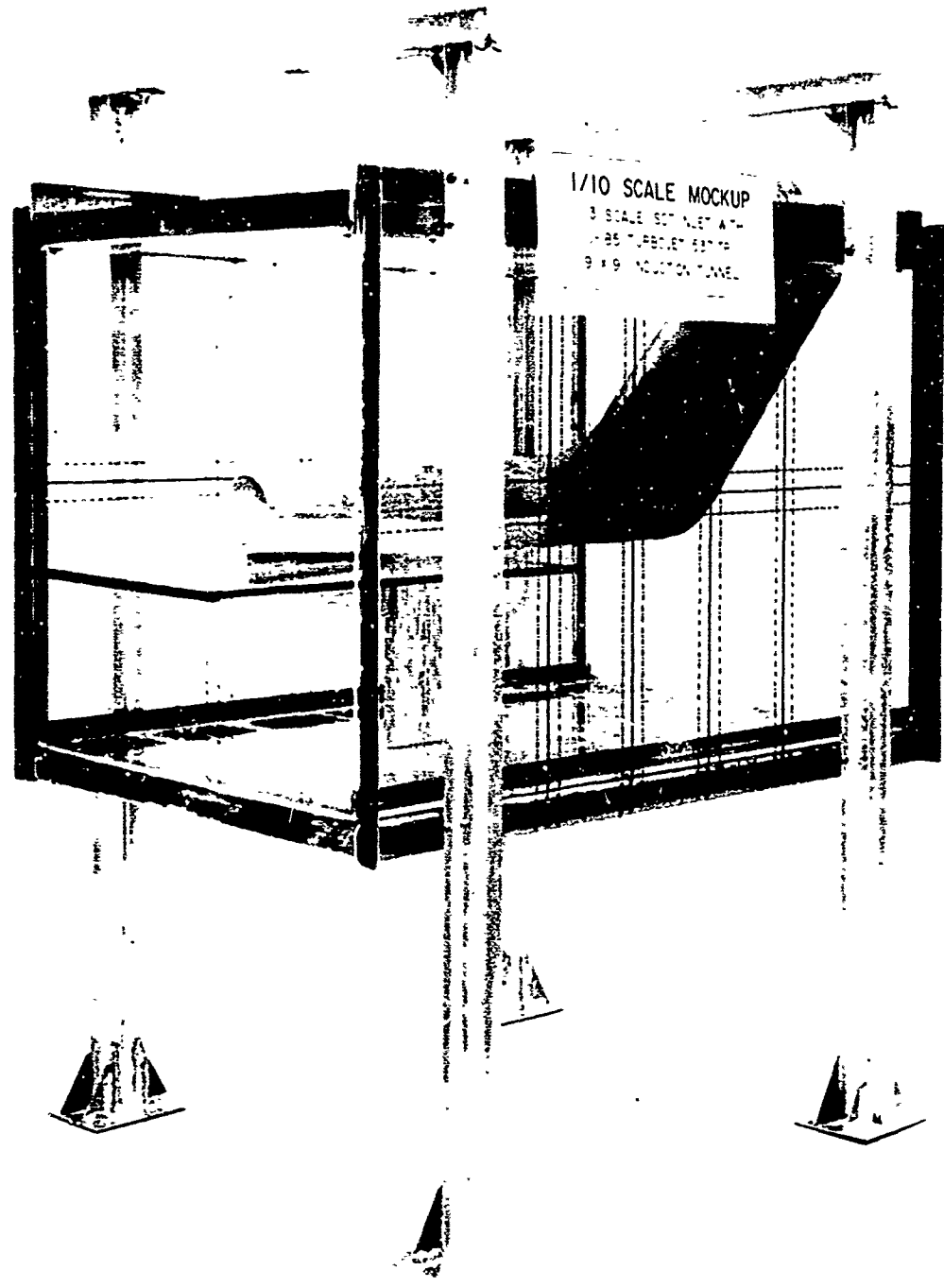
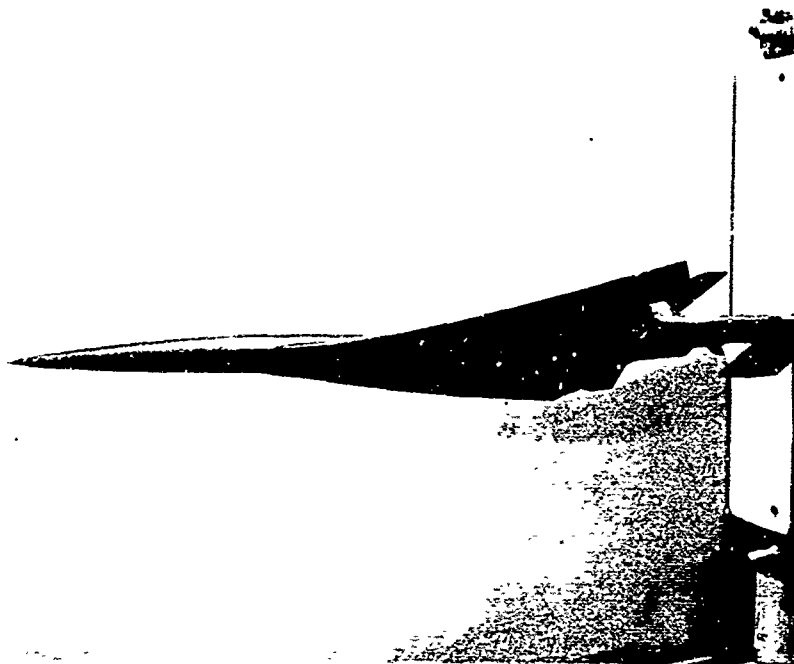


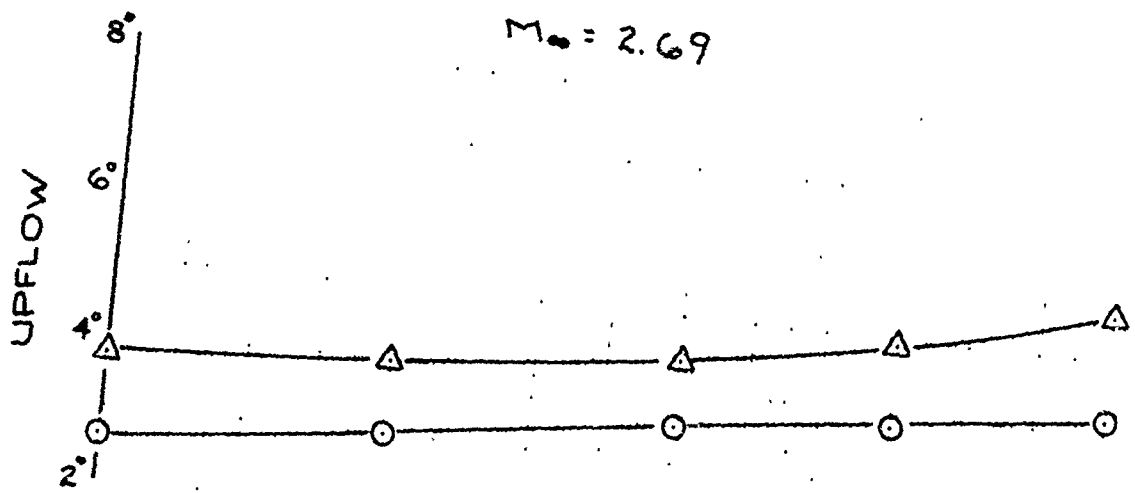
Figure 59. Mockup of One Third-Scale SST Inlet-Engine

D6-18110-5

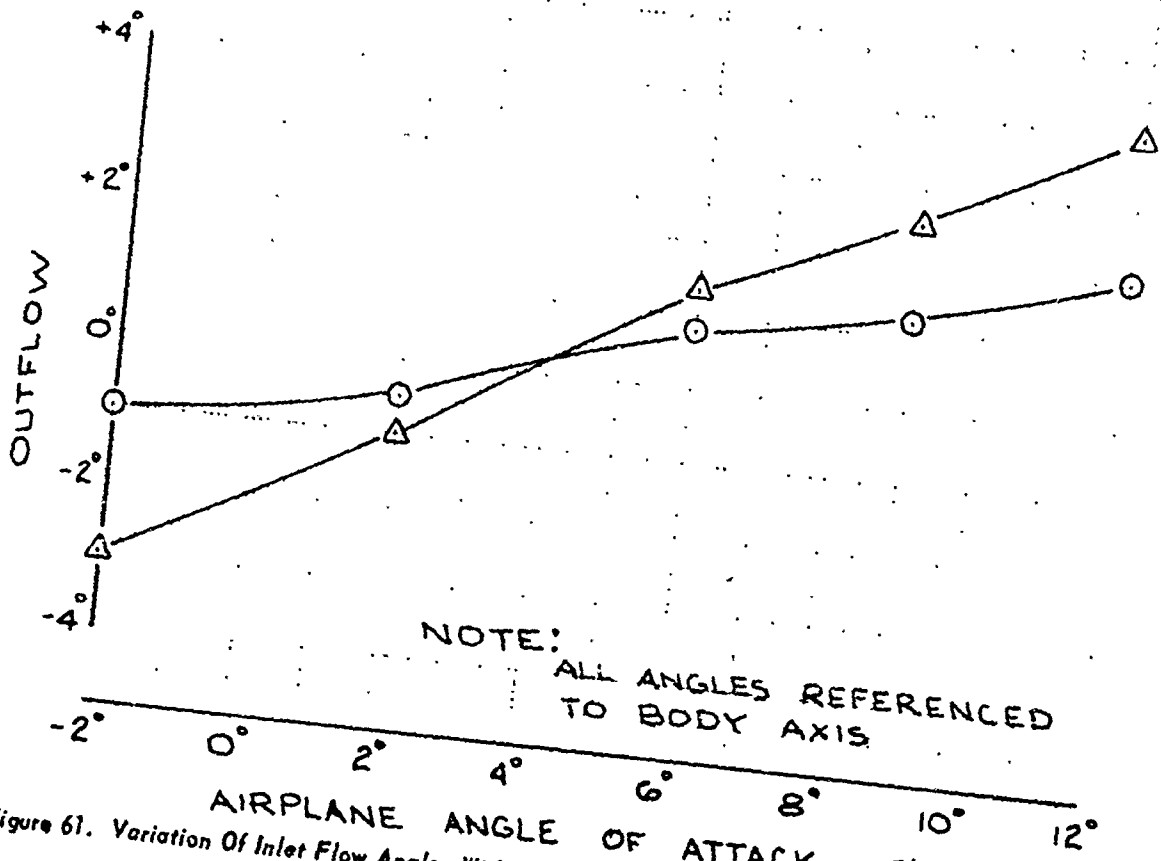


*Figure 60. Inlet Flow Field Rakes Installed on B-2707 Configuration*

D6-18110-5



○ INBOARD INLET  
 △ OUTBOARD INLET



NOTE:  
 ALL ANGLES REFERENCED  
 TO BODY AXIS

Figure 61. Variation Of Inlet Flow Angles With Airplane Angle Of Attack.

$M_{\infty} = 2.69$

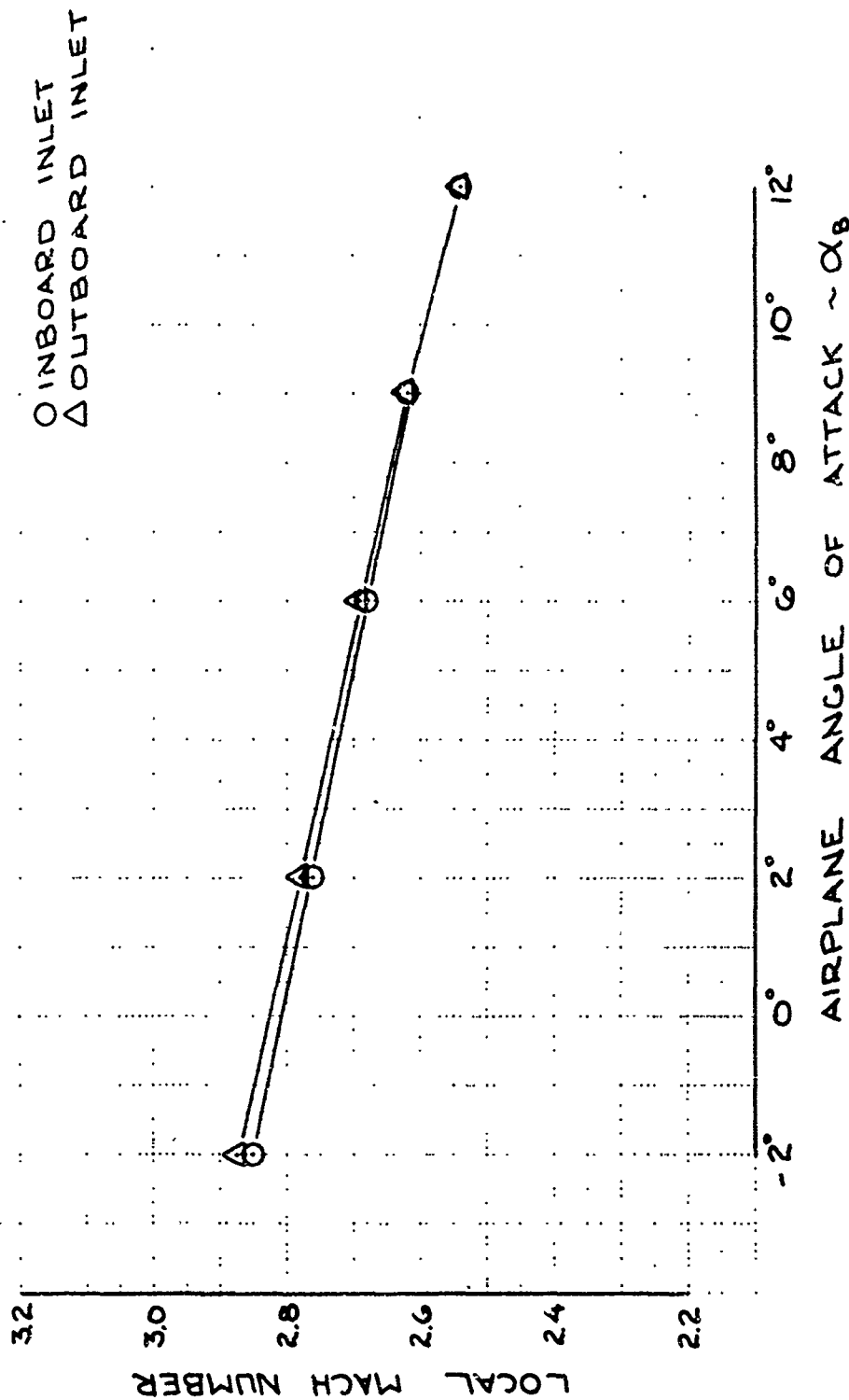


Figure 62. Variation Of Inlet Local Mach Number With Airplane Angle Of Attack

D6-18110-5

**MODEL DESCRIPTION**

**TEST COMPLETED**

**TEST PLANNED**

April May June July August

Fluid Control for Stability Bleed Augmentation  
 Facility: Bench Test

Effects of Subsonic Diffusor/Bypass Plenum Contours on Recovery and on Distortion  
 3-Inch Inlet  
 Facility: 6 x 0 Inch VN Tunnel

Inlet Performance and Control System Evaluation  
 1/5-Scale Model  
 Performance and Control Signals. Fixed Geometry Performance  
 Variable Diameter Centerbody Performance and Control Signals. Variable Centerbody and Bypass System  
 Control Signal Study and analog Controller Operation  
 Control dynamics Test  
 Facility: 18 x 18 Inch VN Tunnel

Inlet Control Pressure Signal Test in the Unstarted Mode,  $M = 1.2 - 1.6$   
 3-Inch Inlet  
 Facility: 18 x 18 Inch VN Tunnel

Inlet Rear Bypass Door Effectiveness Evaluation (Internal Flow Only)  
 1/10-Scale Model  
 Facility: Special Setup

Reverser Ingestion Test  
 1/20-Scale Airplane Model  
 Facility: 9 x 9 Foot Low Speed Tunnel

Nozzle Performance Test  
 5-Inch Models  
 GE & P&W Nozzles  
 Facility: Static Rig  
 4 x 4 Foot BSWT  
 8 x 10 Foot BSWT

Reverser Performance Test  
 1/10 Scale  
 Facility: Static Rig

Static Jet Wake Test  
 3-Inch Nozzle and Burner  
 Facility: Mechanical Labs

Tanconi; Inlet Choked Mode Testing and Inlet-Airframe Low-Speed Compatibility Test:  
 1/10-Scale - Tanconi, Heine, B-270; Cont. 1  
 1/3-Scale Inlet - Jop Engine Test  
 Facility: 9 x 9 Foot Low-Speed Tunnel

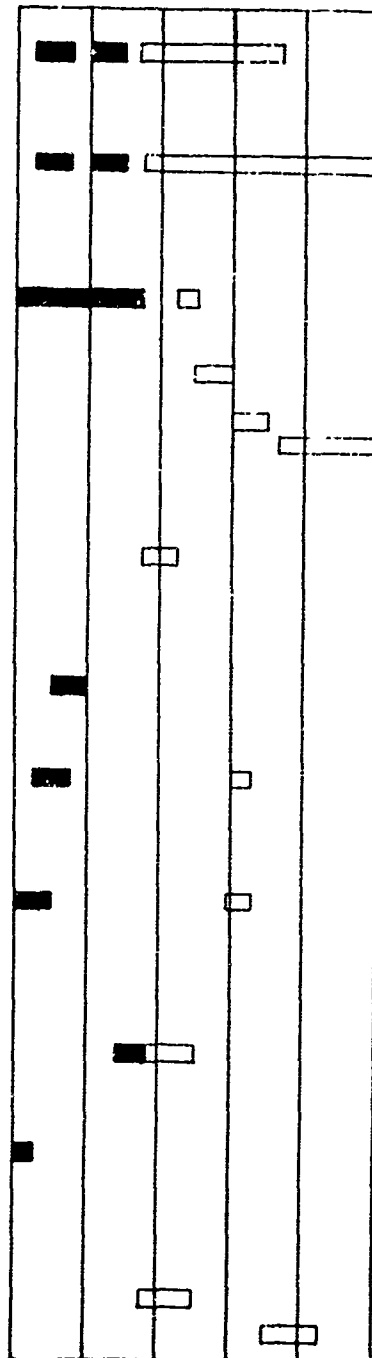


Figure 63. Propulsion Testing Schedule

D6-18110-5



*Figure 64. Full-Scale Test Centerbody, Expanded Position*

D6-18110-5

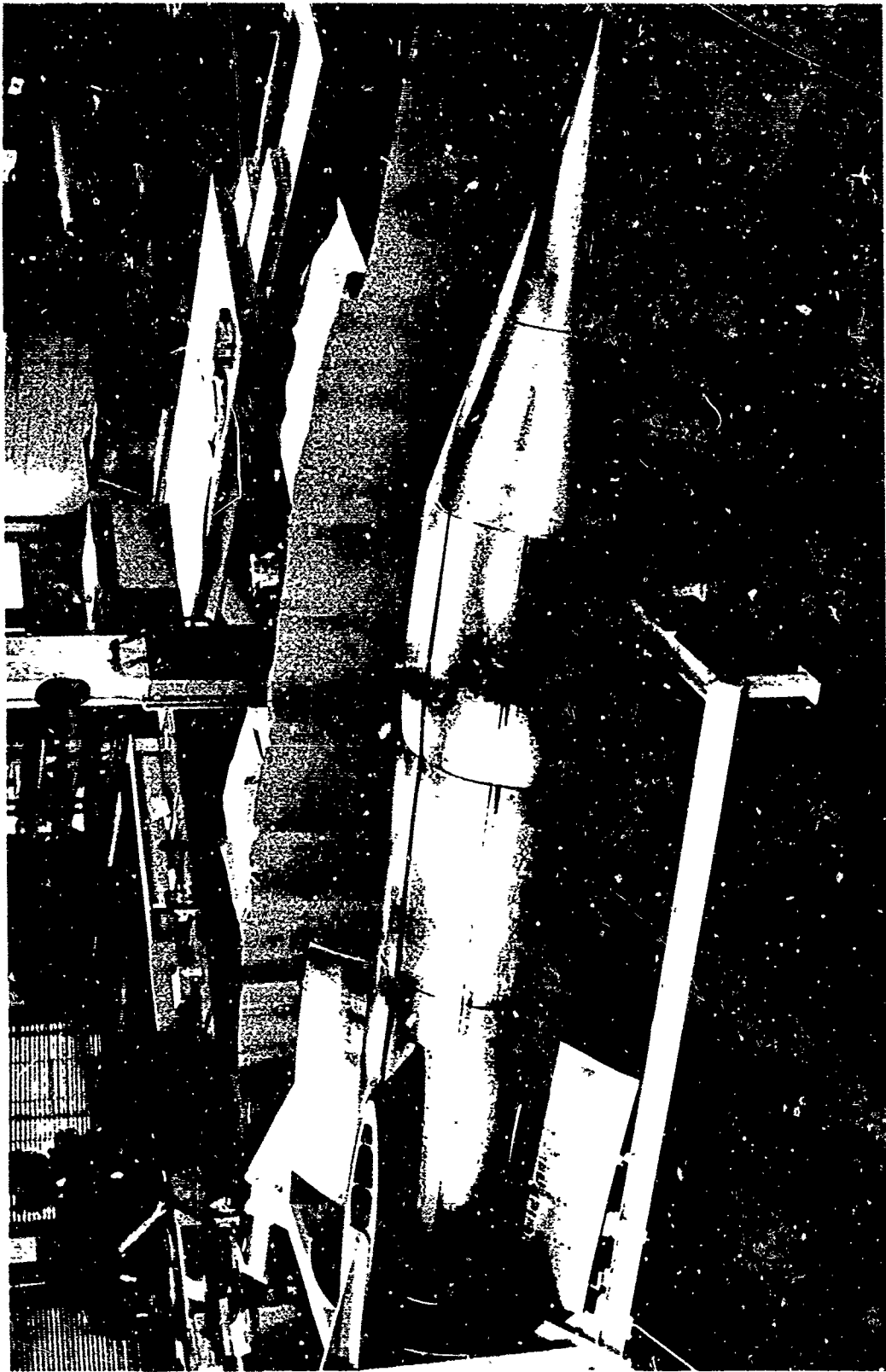


Figure 65. Full-Scale Test Centerbody, Contracted Position

D6-18110-5

### III. Description of Technical Progress (continued)

#### 1302. Air Induction System (continued)

The test tank fixture is also being completed on schedule. Installation of the test centerbody into the tank is scheduled for the week starting May 30, 1966.

##### (b) Mockup

The full scale mockup of the complete inlet assembly was completed on May 25. The outer cowl of the mockup incorporates operating bypass doors and centerbody bleed air exit louvers. This is a developmental mockup and will be updated as required. Figures 66 and 67 are photographs of the completed assembly.

#### 1303. Air Induction Control

##### (1) Inlet-Engine Simulation

The digital simulation of the inlet and GE engine has been used to determine transient operation of the propulsion system when subjected to various disturbances. Figure 68 shows the effect of augmentor blow-out during climb at maximum augmented power. The blowout was triggered at time = 0.3 seconds. The loss in tailpipe temperature caused the back pressure on the turbine to be relieved, thus allowing the engine rpm and weight-flow to increase momentarily. The engine fuel control sensed the increase in rpm and changed fuel flow and nozzle area to restore engine rpm. The inlet bypass loop controlled the normal shock satisfactorily, thus maintaining distortion within allowable limits.

Several runs were made on the hybrid computer simulation to determine compatibility of the inlet with the P&W engine. Freestream Mach number, ambient pressure, ambient temperature, and angle of attack were varied at Mach 2.7 cruise to simulate tail and vertical gusts (several magnitudes and rates), effect of passing airplane, ambient temperature increase, and airplane maneuver. Preliminary analysis shows that the control system maintains satisfactory operation for these upstream disturbances. The tracings are being prepared for use in future documentation.

A simplified inlet simulation was prepared and sent to P&W for use with their engine simulation. The equations were linearized and are valid for small changes around the cruise condition ( $M = 2.7$ ).

##### (2) Inlet Control Sensor Bench Test

Dynamic bench testing of the entire centerbody control loop has been completed using the Hamilton Standard centerbody control sensor. The control loop was tested at conditions corresponding to local Mach numbers of 1.8 to 2.55. The inlet aerodynamic feedback gains were programmed on the analog computer included in the bench test setup. (A block diagram of the bench test setup is presented in Fig. 69.) The tests were conducted with both Hamilton Standard and Moog servo-valves.

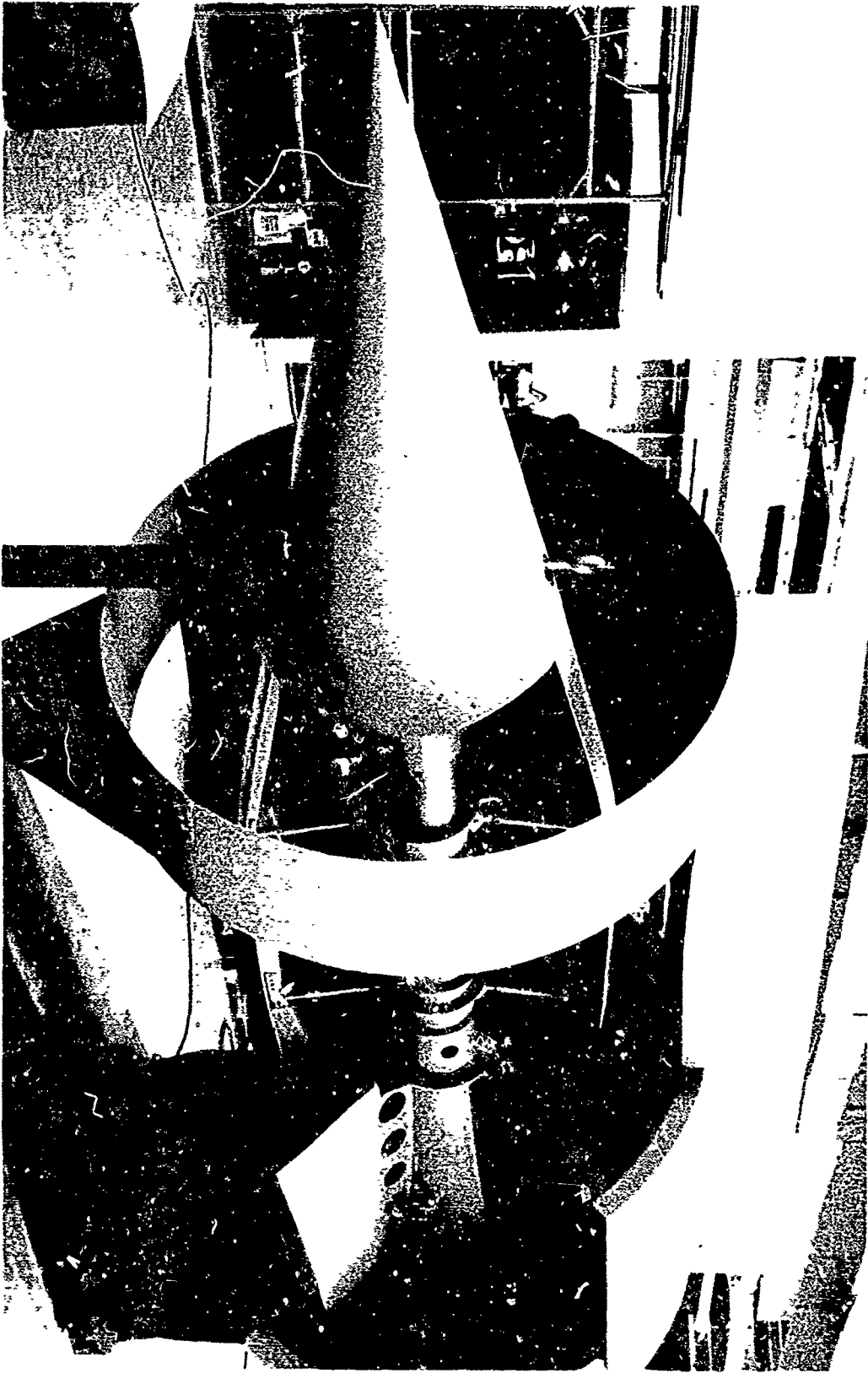


Figure 66. Full-Scale inlet Mockup



*Figure 67. Full-Scale Inlet Mockup*

D6-18110-5

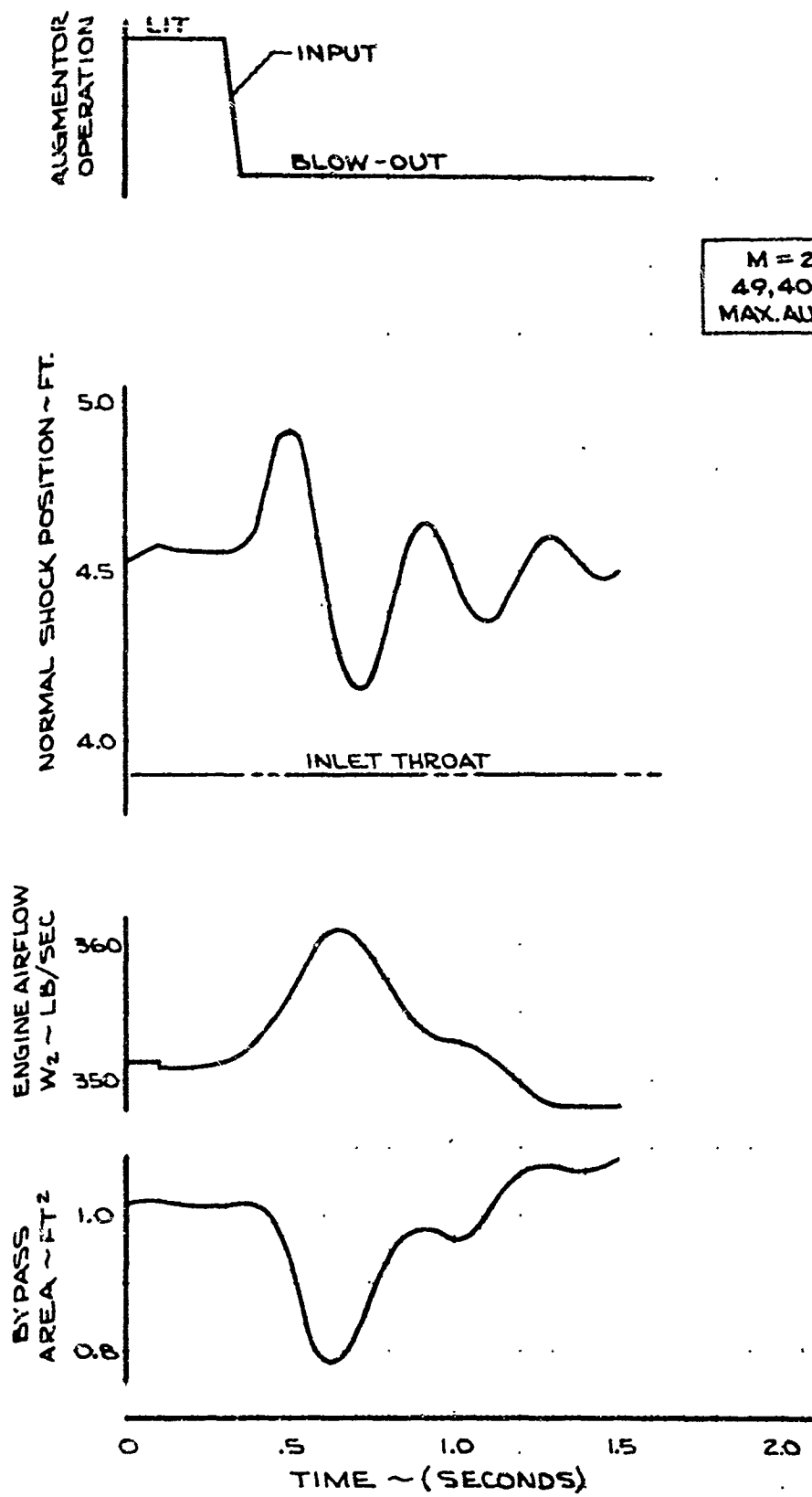


Figure 68. Augmentor Blowout, GE Engine and Inlet

D6-18110-5

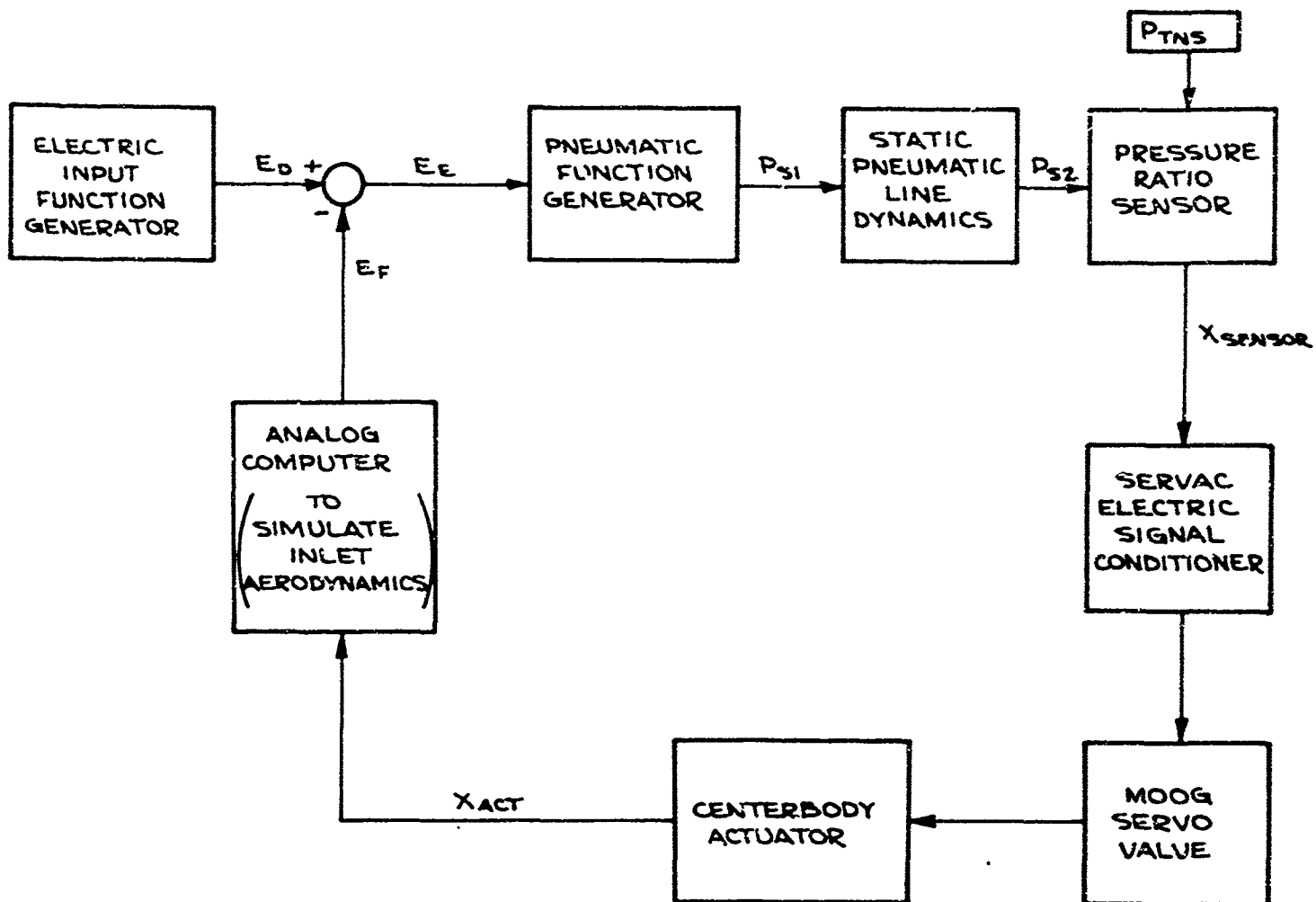


Figure 69. Control Sensor Bench Test Block Diagram

### III. Description of Technical Progress (continued)

#### 1303. Air Induction Control (continued)

The Moog valve was operated by an electrical signal generated by the translation of the sensor linkage and passed through a Servac electric signal conditioner. The Servac signal conditioner permitted variation of the loop gain to any desired value.

The testing was conducted with the loop gain optimized for the Mach 1.8 condition, since the transfer function that simulates the inlet aerodynamics had the largest gain at this Mach number. The aerodynamic loop gain function was based on inlet test data, which exhibited considerable scatter and variation from the theoretical values. New data will be obtained on the 1/5-scale inlet and the bench test results will be adjusted. Results of this series of tests at Mach 1.8 and 2.55 are shown in Figs. 70 and 71.

The approximate overall loop time constants calculated from Figs. 70 and 71 are 0.08 seconds for Mach 1.8 and 0.24 seconds for Mach 2.55. Boeing-inlet-engine mathematical simulation studies indicated that the centerbody loop time constant required for an inlet Mach number disturbance with  $d M_T/d_t = 1$  Mach/sec. was approximately 0.08 seconds. The bench test results thus indicate that the loop response at the Mach 1.8 condition is satisfactory but that for Mach 2.55 is not. However, if the new aerodynamic loop gain function is found to approach the theoretical values, satisfactory response would be achieved over the entire range.

To investigate the loop response when the overall loop gain is optimized at each local Mach number, a series of tests were run selecting optimum Servac gain for each local Mach number condition being tested. An example of test results in this test series is presented in Fig. 72. The figure shows the loop response is now as good as that of Mach 1.8 condition shown in Fig. 70. If improvements are not found in the aerodynamic loop gain function, the centerbody loop gain may have to be scheduled as a function of the local Mach number.

During the loop dynamic tests data were taken to study the response characteristics of components included in the centerbody loop. Figures 73 through 75 show the Bode plots across the pneumatic line, the centerbody sensor, and the Moog valve, respectively. It is apparent that the pneumatic line and the sensor response are sufficiently fast in relation to the actuator response (which includes the effect of the inlet aerodynamic feedback). The Bode plots are being curve-fitted to derive the component transfer functions.

To study the electronic inlet control system concept, Boeing has been developing electronic control sensors. Some of the test results of the electronic centerbody sensor under development are presented in Figs. 76 through 79.

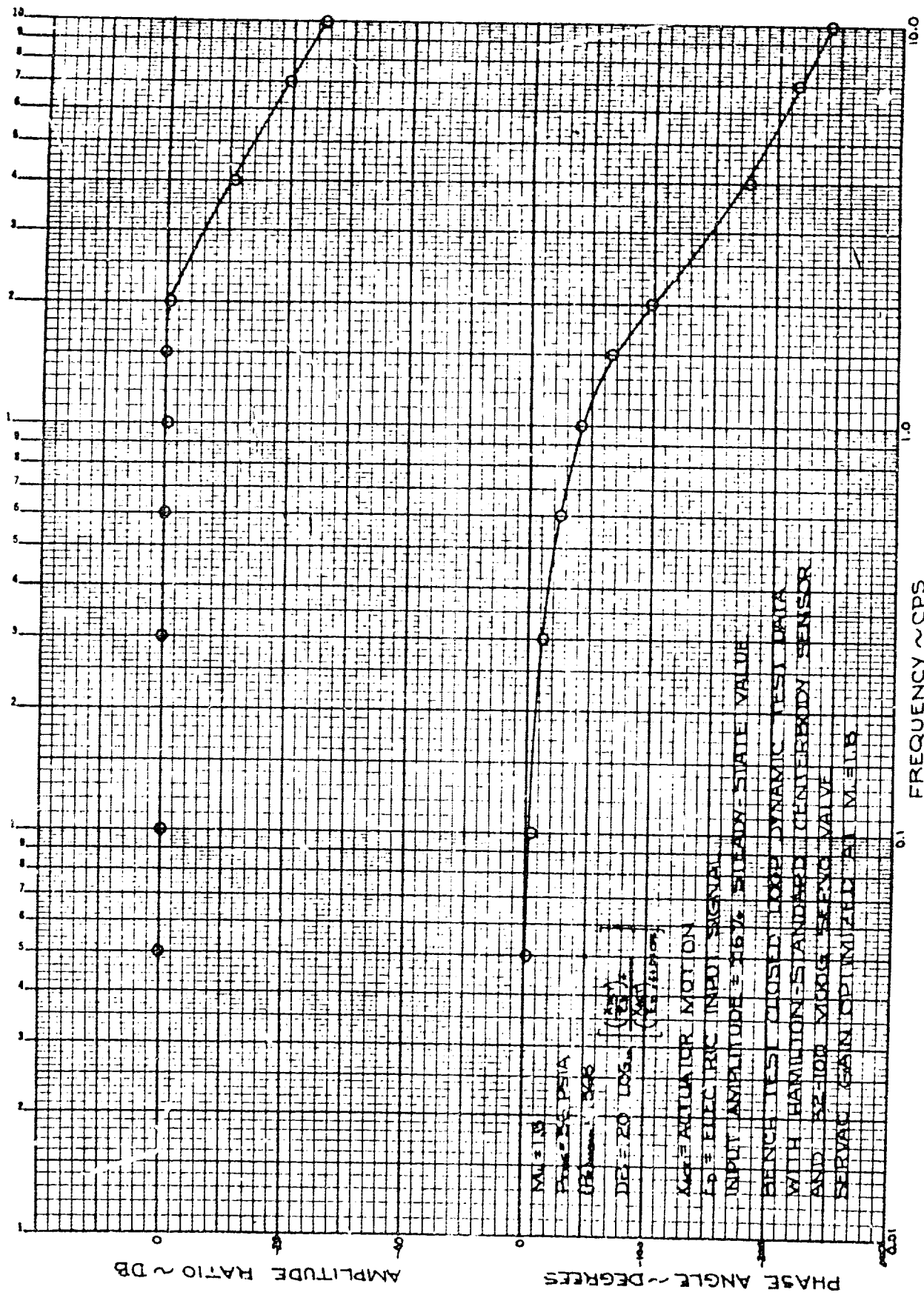


Figure 70. Centerbody Loop Test with Hamilton Standard Sensor, M<sub>L</sub> = 1.8

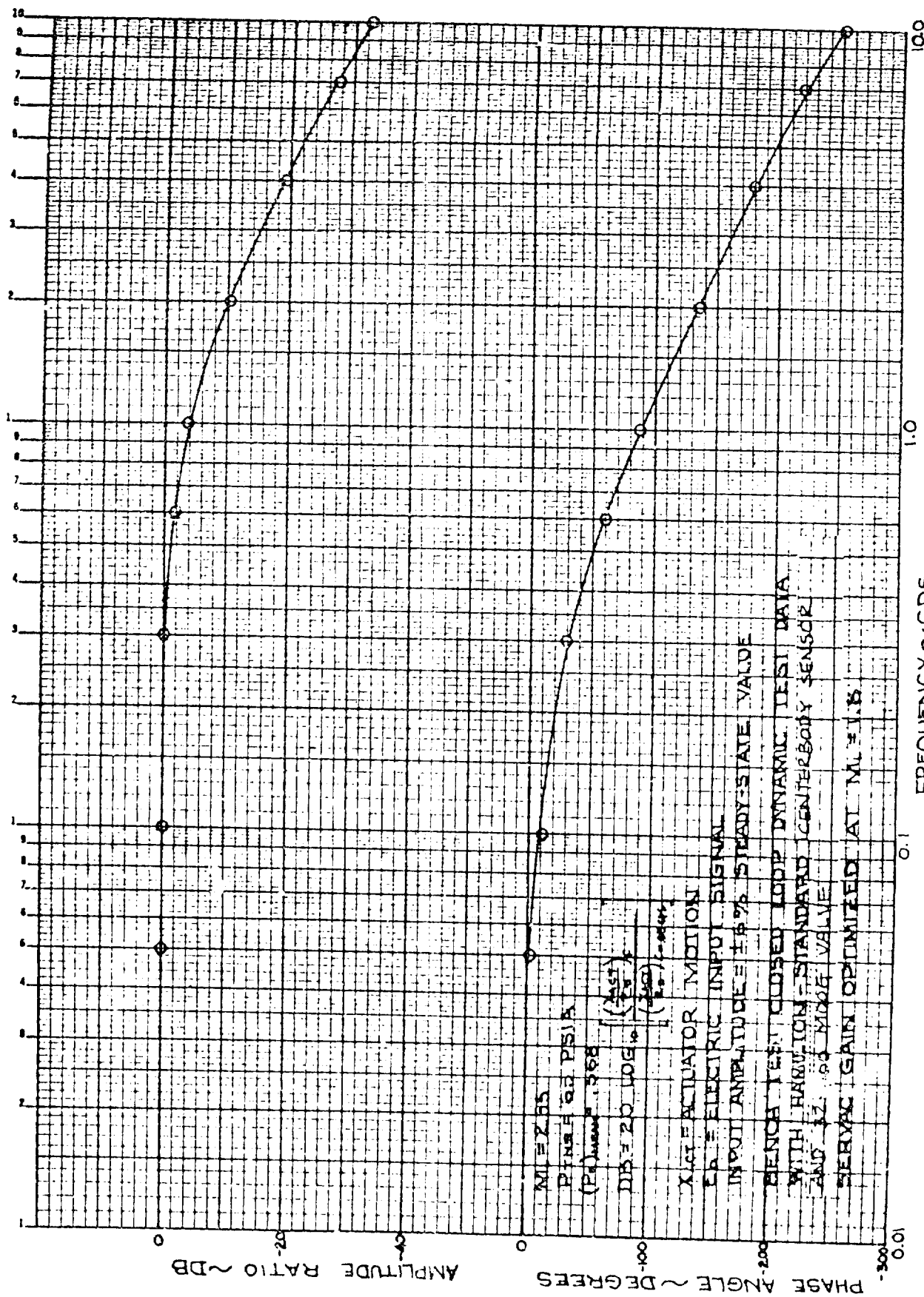


Figure 71. Centerbody Loop Test with Hamilton Standard Sensor,  $M_L = 2.55$

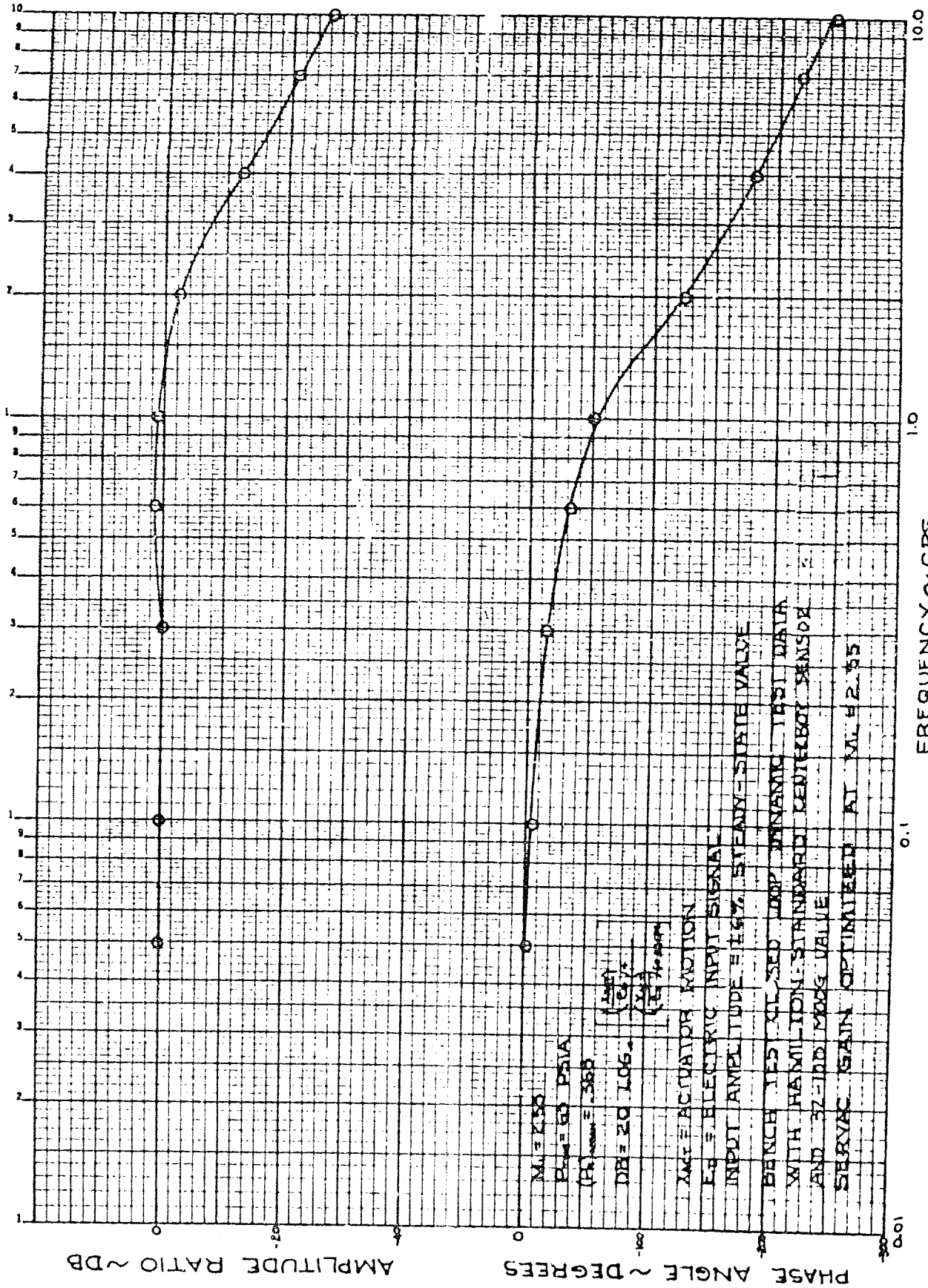


Figure 72. Centerbody Loop Test with Hamilton Standard Sensor,  $M_L = 2.55$ , Optimized

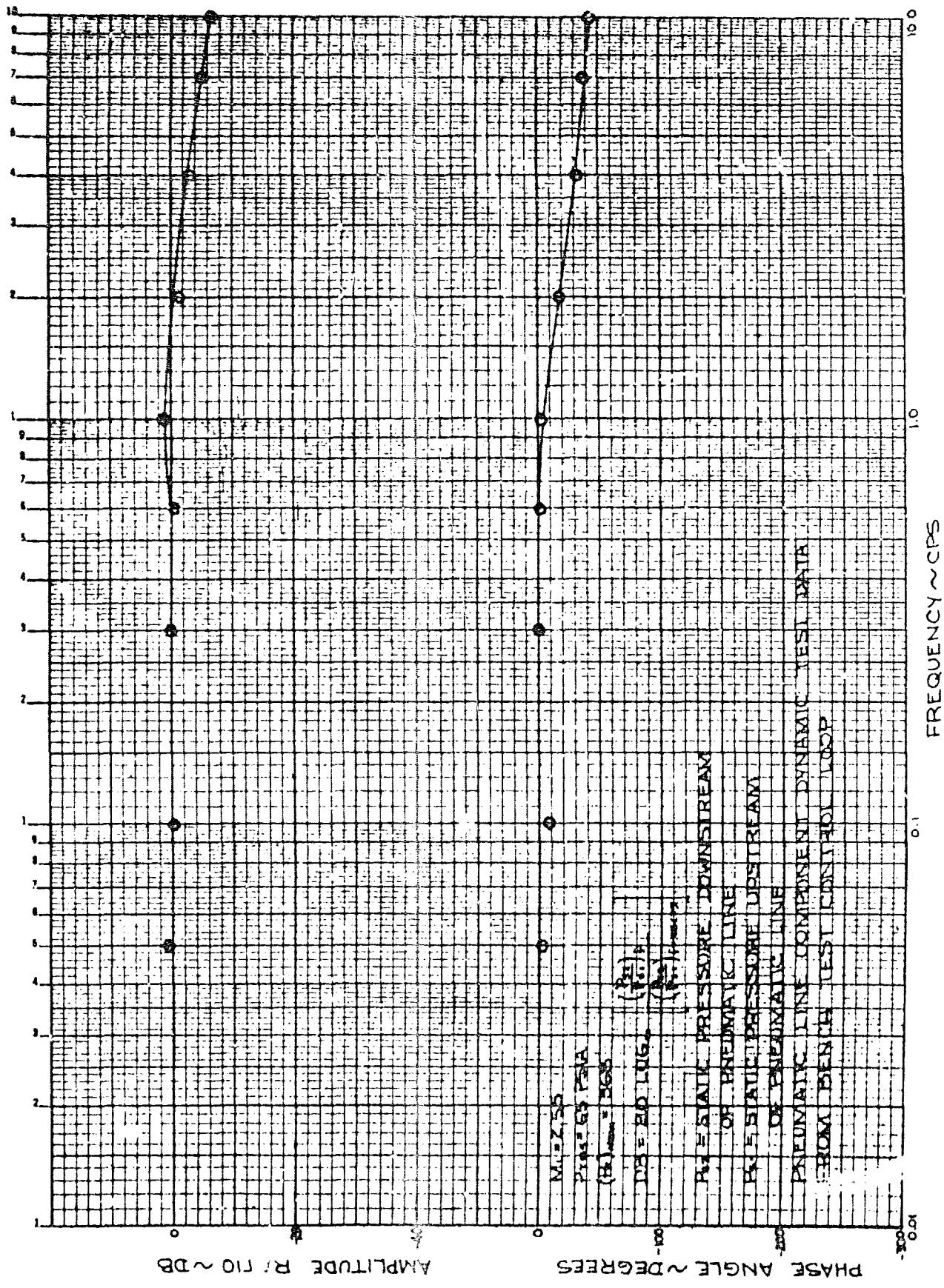


Figure 73. Pneumatic Line Response Characteristics, Centerbody Loop

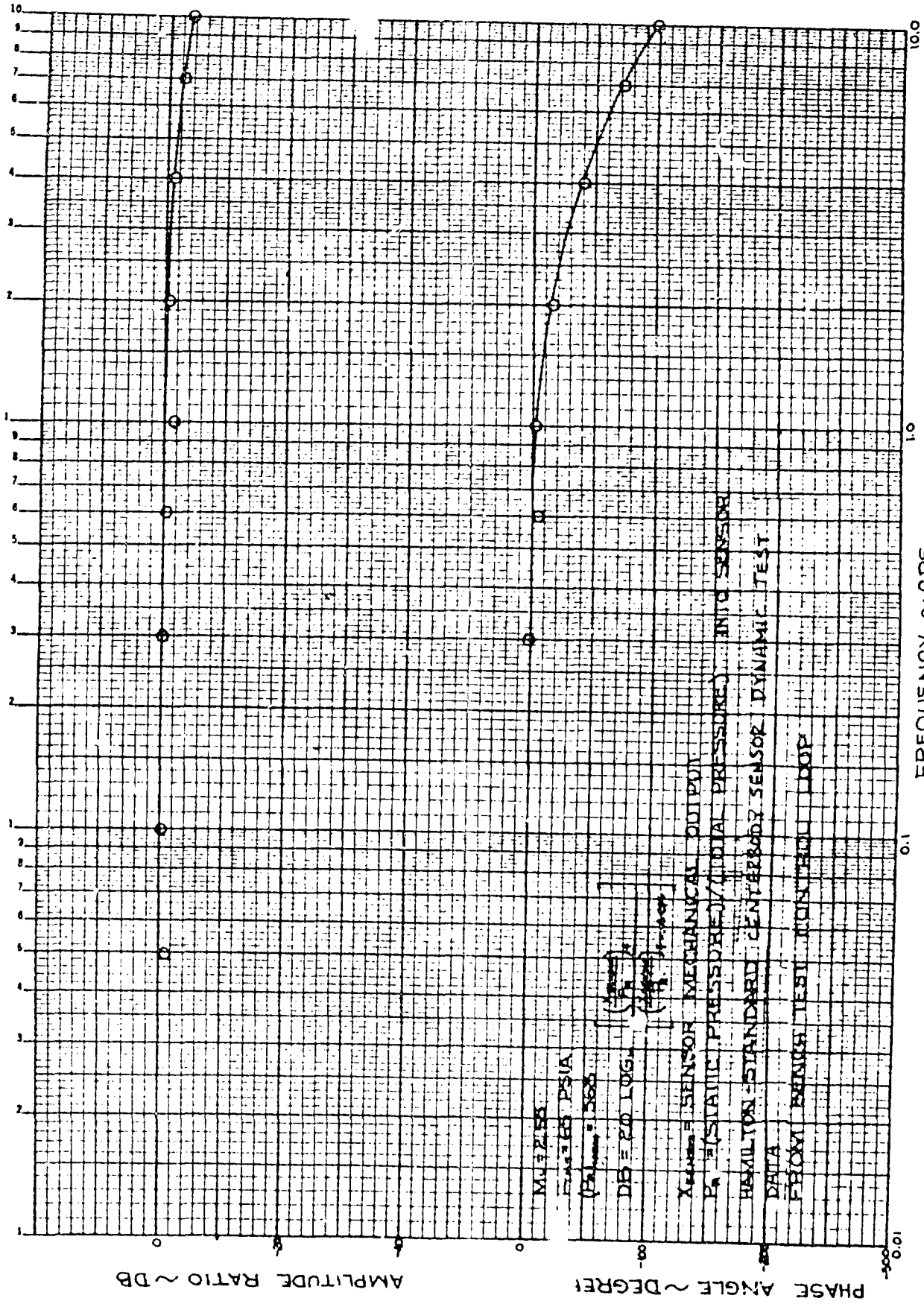


Figure 74. Hamilton Standard Centerbody Sensor Response Characteristics

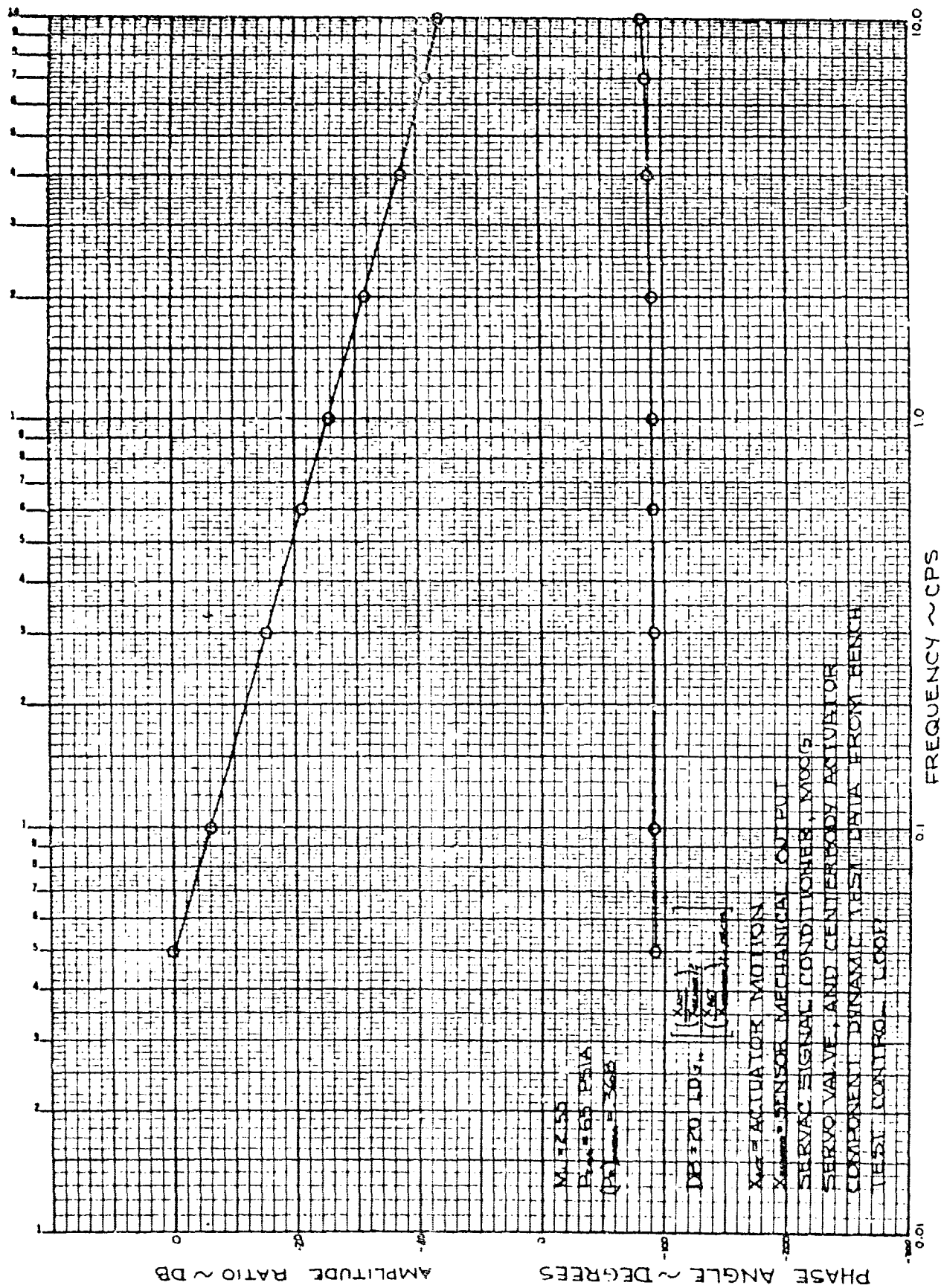


Figure 75. Centerbody Actuator Response Characteristics

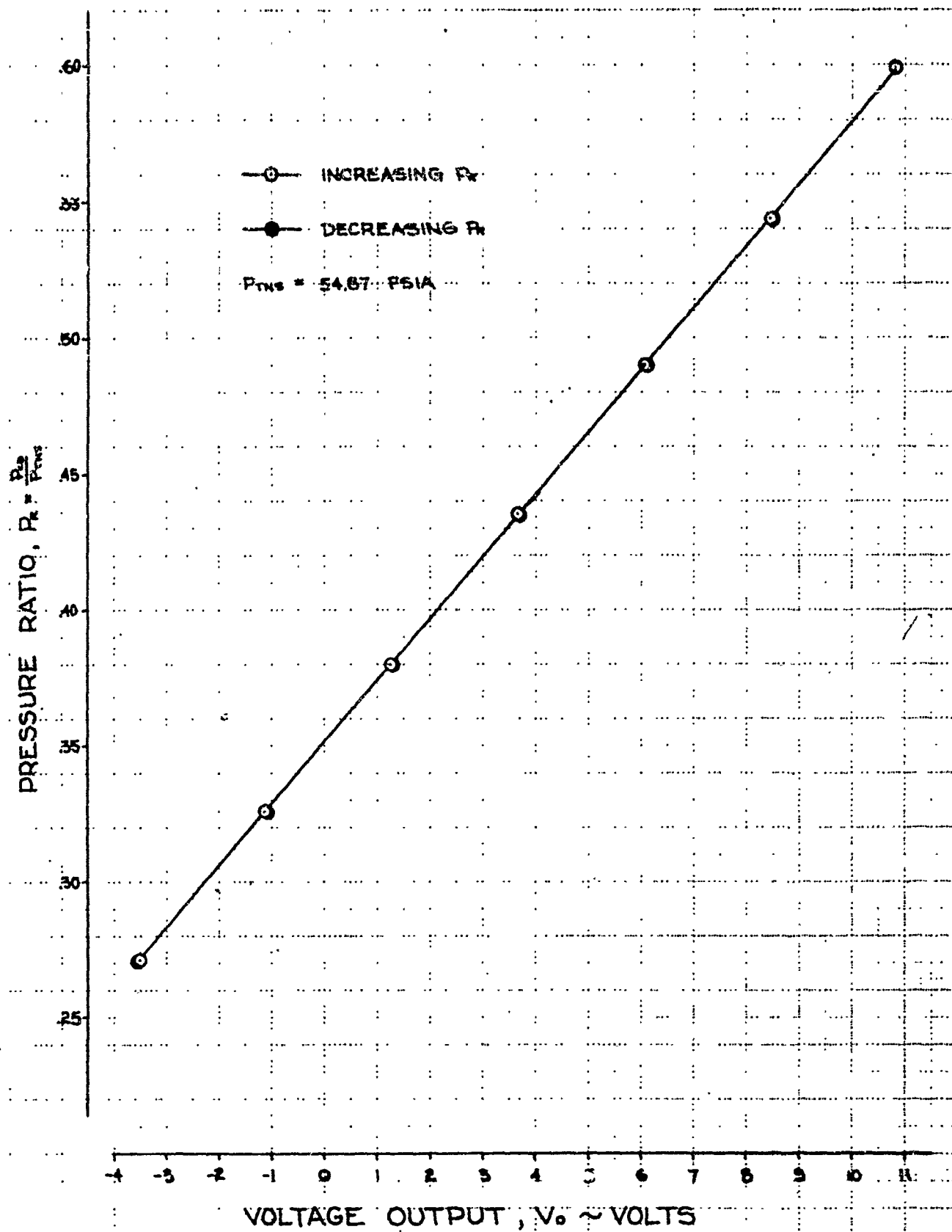


Figure 76. Electronic Centerbody Controller Hysteresis Test

D6-18110-5

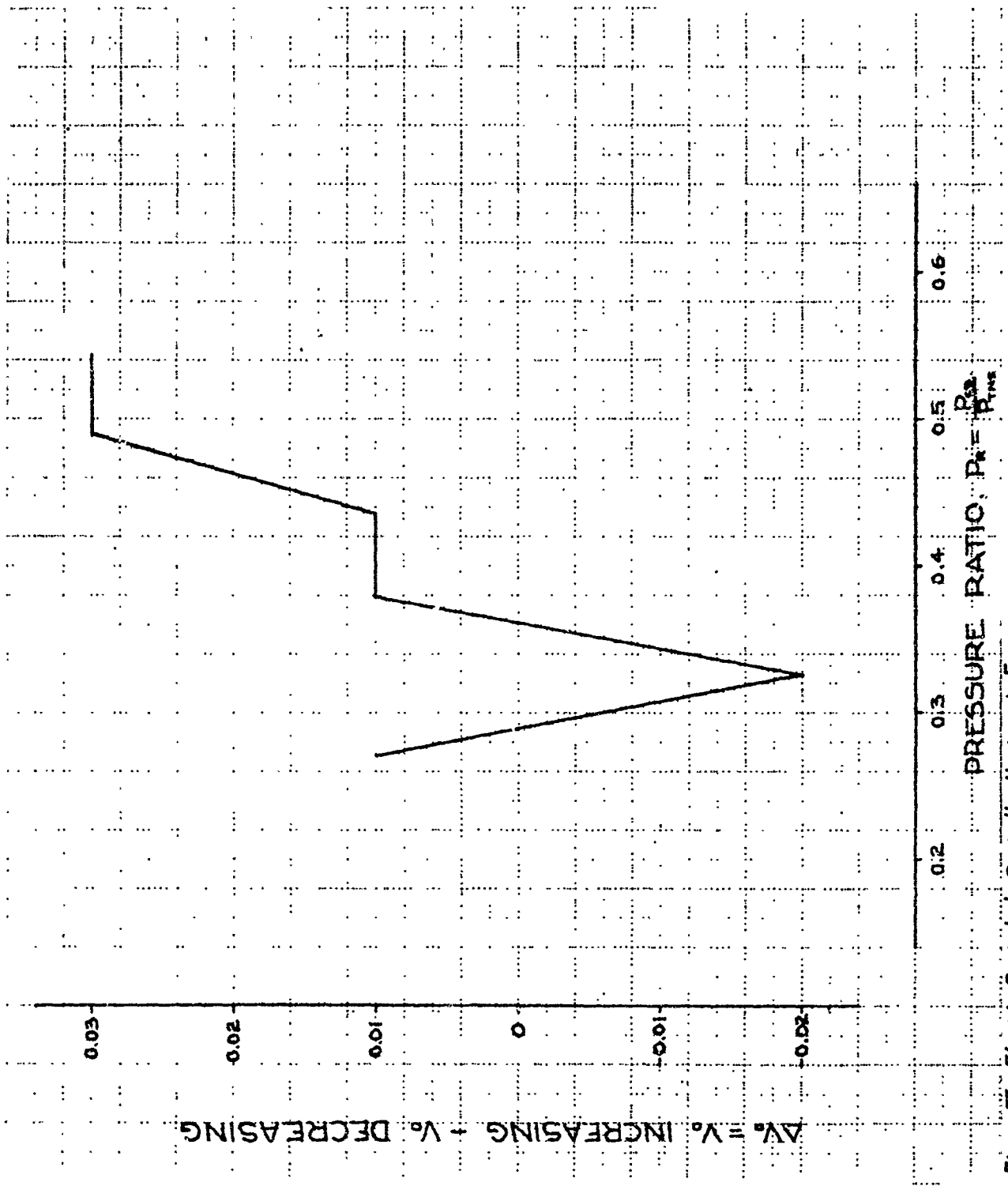


Figure 77. Electric Centerbody Controller Hysteresis Error

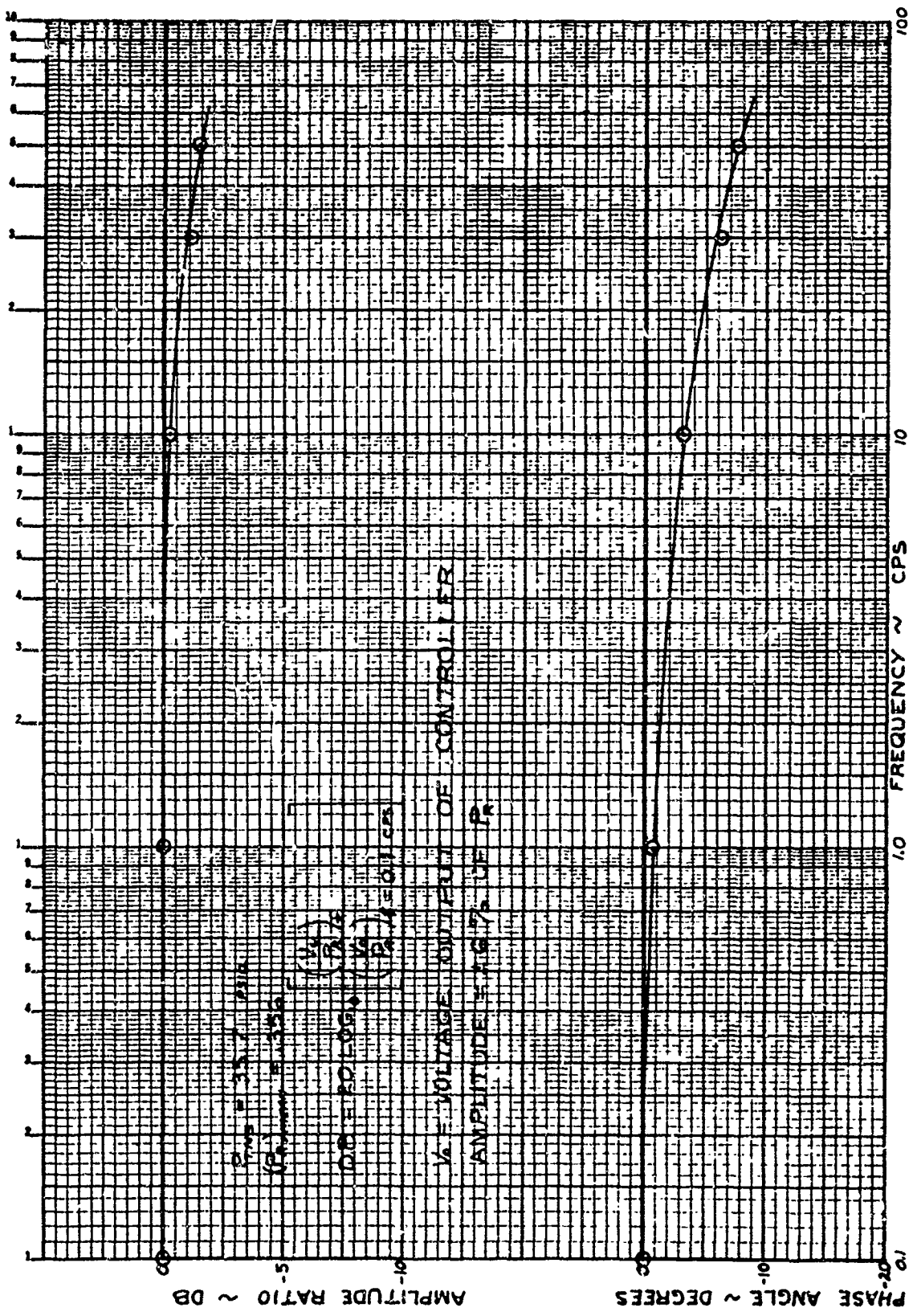


Figure 78. Boeing Electronic Centerbody Sensor

D6-18110-5

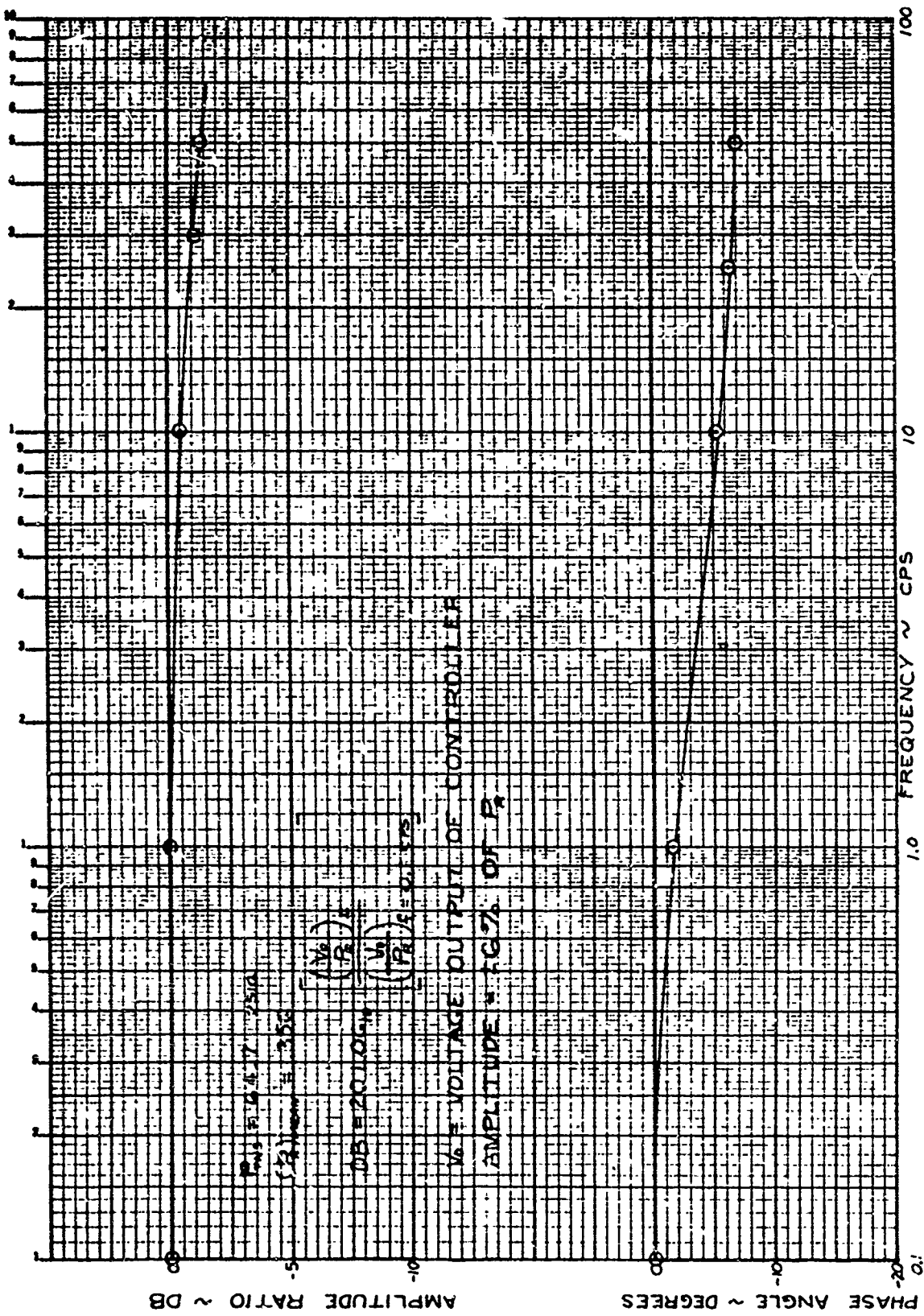


Figure 79. Centerbody Controller Dynamic Test

D6-18110-5

### III. Description of Technical Progress (continued)

#### 1303. Air Induction Control (continued)

Figure 76 shows the result of hysteresis test, and Fig. 77 shows the hysteresis error calculated from the hysteresis test. The maximum hysteresis error, which includes the error of test equipment, was approximately 0.2 percent in terms of  $P_R/P_R$ .

Figures 78 and 79 are two Bode plots of the results of the dynamic testing of the electronic sensor alone at two extreme pressure levels at room temperature. As expected, the sensor was found to be much faster than the hydromechanical Hamilton Standard centerbody sensor (Ref. February and March Technical Progress Report for the Hamilton Standard sensor Bode plot).

#### (3) Inlet Model Wind Tunnel Test

A 3.184 inch lip diameter inlet model was tested in the Boeing 6 by 6 inch variable Mach supersonic wind tunnel to investigate the influence of rear bypass doors on external compression mode control pressure signals. The model consisted of a cowl with variable area bypass doors at the compressor face and a fully contracted centerbody.

Tests were run at Mach numbers from 1.34 to 1.8. The airflow discharged through the bypass doors was varied while the inlet capture airflow was held constant. The test indicated that rear bypass flow does not significantly influence the forward cowl static pressures from which the control pressure signals will be selected.

The 1/5-scale inlet (11.24-inch lip diameter) control signal test with the fixed geometry centerbodies is now in progress. Preliminary test results confirm the control signal pressure tap locations for the centerbody control and normal shock control determined from the 3-inch lip diameter inlet model tests. Figure 80 shows the variation in the normal shock control signal at several Mach numbers during supercritical operation of the 1/5-scale inlet. These test results indicate the feasibility of using constant reference signals.

Preparation for the inlet control system test with the variable geometry 1/5-scale inlet and an analog computer is on schedule. Control sensor and pneumatic line transfer functions have been determined and the analog system is being assembled. The final details of the order of testing are being determined.

#### (4) Control Vendor Coordination

A preliminary procurement specification for the inlet control and flight deck display system was prepared and the copies were issued to control vendors on May 2. Proposals on the procurement specification are expected by June 10.

A number of meetings were held between vendors and Boeing to discuss the advanced control pressure ratio sensors being developed by the vendors.

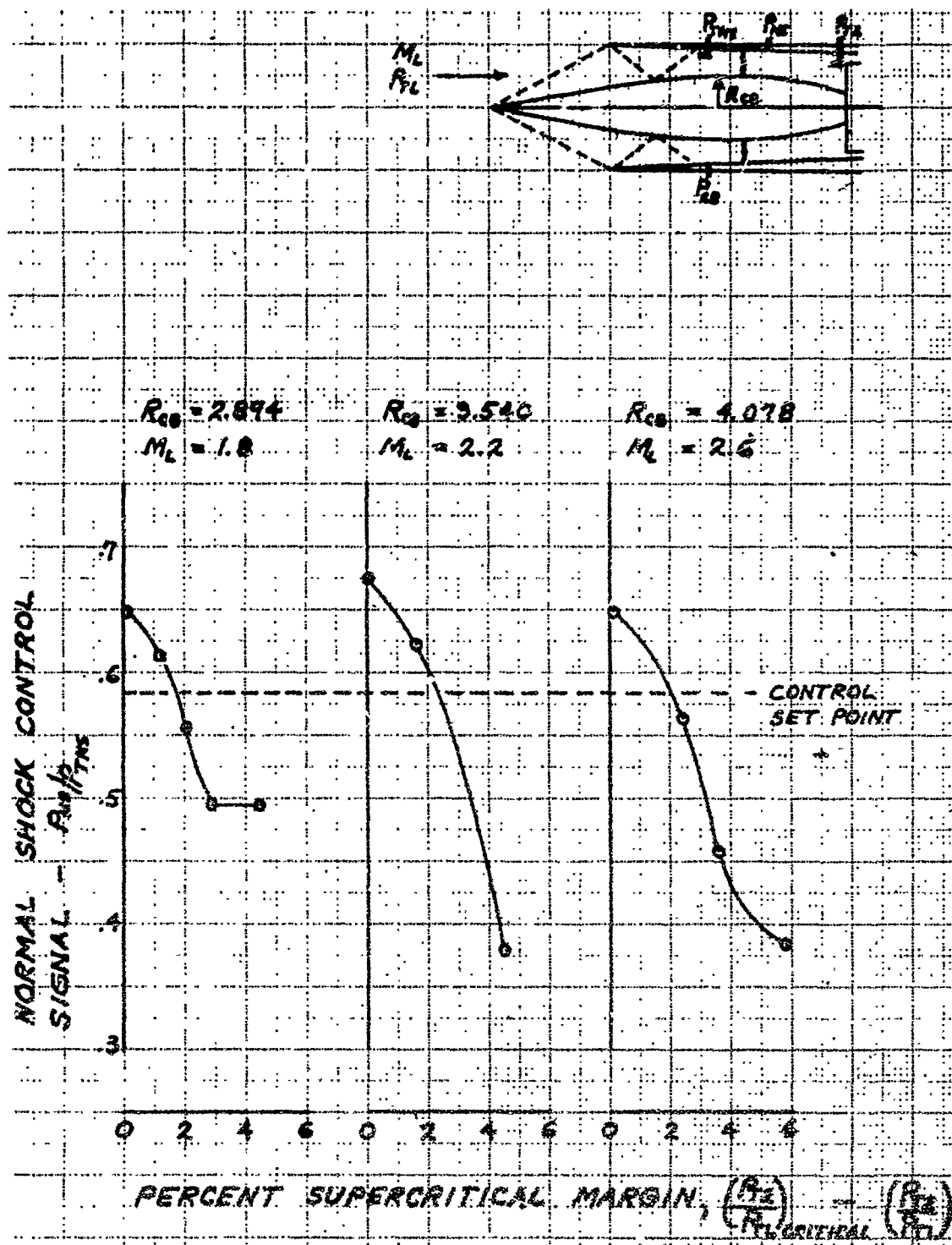


Figure 80. Bypass Control Signal Characteristics

D6-18110-5

### III. Description of Technical Progress (continued)

#### 1305. Propulsion Installation

##### 13054. ENGINE INSTRUMENTATION

The essential instrumentation for the engine has been coordinated and agreed upon with both GE and P&WA. This instrumentation is comprised of nine instruments that are required to operate the engine properly and include those required to fulfill FAR requirements. However, the complete instrumentation list, which will include approximately 28 items, is still under negotiation because of three items that are affected by possible changes in engine configuration. These instruments are: (1) secondary air valve position indicator; (2) thrust reverser cascade cover position indicator; and (3) exhaust nozzle total pressure indicator.

The completion of the first draft of the thrust measuring system procurement specification will be completed in mid-June. Tentative requirements for the thrust indicating system for the B-2,07 have been established as well as a preliminary work plan for development of the thrust indicating system. Preliminary requirements for an EPAR system for thrust indication has been sent to vendors. To date three proposals have been received, two of which are essentially refinements of previously submitted proposals. One vendor has, however, offered a completely solid state computer and an improved indicator movement in addition to their previously proposed capacitance pressure transducer. This proposal appears to be a significant improvement in thrust indicating systems and is applicable with either the EPAR system or the PPAR system proposed by General Electric. It may also have application to a direct thrust indicating system. A design study has been completed on a direct thrust measuring system.

#### 1306. Fuel System

Ten additional flight cycles using FAS-1 fuel have been completed in the environmental test tank. Laboratory analysis indicates that the insulation stains (see March report) may be partially oxidized fuel. Testing was stopped to apply a diffusion barrier over the insulation. This is being done to improve the insulation efficiency and to determine whether or not the stains are caused by fuel. Test cycling will be resumed in early June.

Cell and panel fabrication for United States Rubber Company fuel bladder cells was delayed to improve fitting pull strength. Testing is expected to start by mid June. High temperature cycling of Goodyear cube and panels started May 24, 1965.

Thompson Ramo Wooldridge has been selected as the fuel booster pump supplier. Purchase orders were issued on May 17, 1966.

### III. Description of Technical Progress (continued)

#### 1306. Fuel System (continued)

Fuel system tank arrangement and CG control are shown in section 10013.

#### 1307. Exhaust/Reverser System

##### (1) Thrust Reverser Ingestion Test

A further series of thrust reverser exhaust gas ingestion tests was conducted during April in the 9 by 9 foot tunnel at the Boeing mechanical laboratories. Various cascade locations and vane angles were tested; in each case 50 percent of the gas was exhausted over the wing. Flow was visualized by exhausting steam in some runs; in others ingestion was measured by detecting the presence of heated reverser flow with thermocouples in the inlets.

"Symmetrical" cascade arrangements, in which the underwing flow was discharged evenly to each side, gave reingestion at speeds around 80 knots. However, several "nonsymmetrical" arrangements, in which all the underwing flow was directed outboard and down, were run down to very low speeds without ingestion.

Typical flow patterns, as a function of cascade configuration and speed, are shown in Figs. 81 and 82.

#### 1308. Noise

A series of tests has been conducted in the Boeing model jet facility to aid in developing jet noise suppressors for the SST. These tests have included both General Electric turbojet and Pratt & Whitney turbofan exhaust nozzle simulation. Other configurations tested have included redesign of the ejector section of the nozzle as well as of the primary nozzle itself (see Fig. 83). Noise suppression up to 8 PNdb has been measured.

#### 1309. Engine Coordination

A technical status review of the General Electric GE4/J5 engine development was held at Boeing on April 12, 1966. Discussions covered component development analysis and test experience, inlet-engine compatibility, and noise. Technical data was received from GE for further study by Boeing.

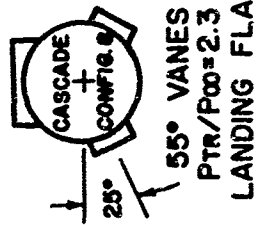
Engine airflow sizing, matching, and noise characteristics were reviewed with Pratt & Whitney on May 12, 1966, and with General Electric on May 20, 1966.



AIRSPED 90 KNOTS



AIRSPED 70 KNOTS (INGESTION)



AIRSPED 120 KNOTS



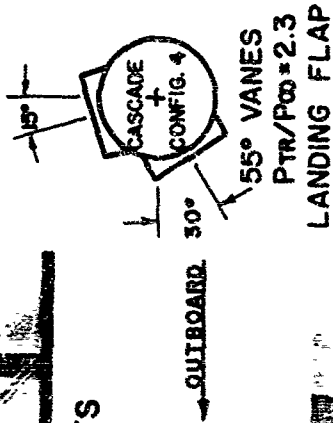
AIRSPED 80 KNOTS

Figure 81. Symmetrical Reverser with Steam

D6-18110-5



AIRSPEED 85 KNOTS



AIRSPEED 50 KNOTS



AIRSPEED 65 KNOTS



AIRSPEED 40 KNOTS

Figure 82. Unsymmetrical Reverser with Steam

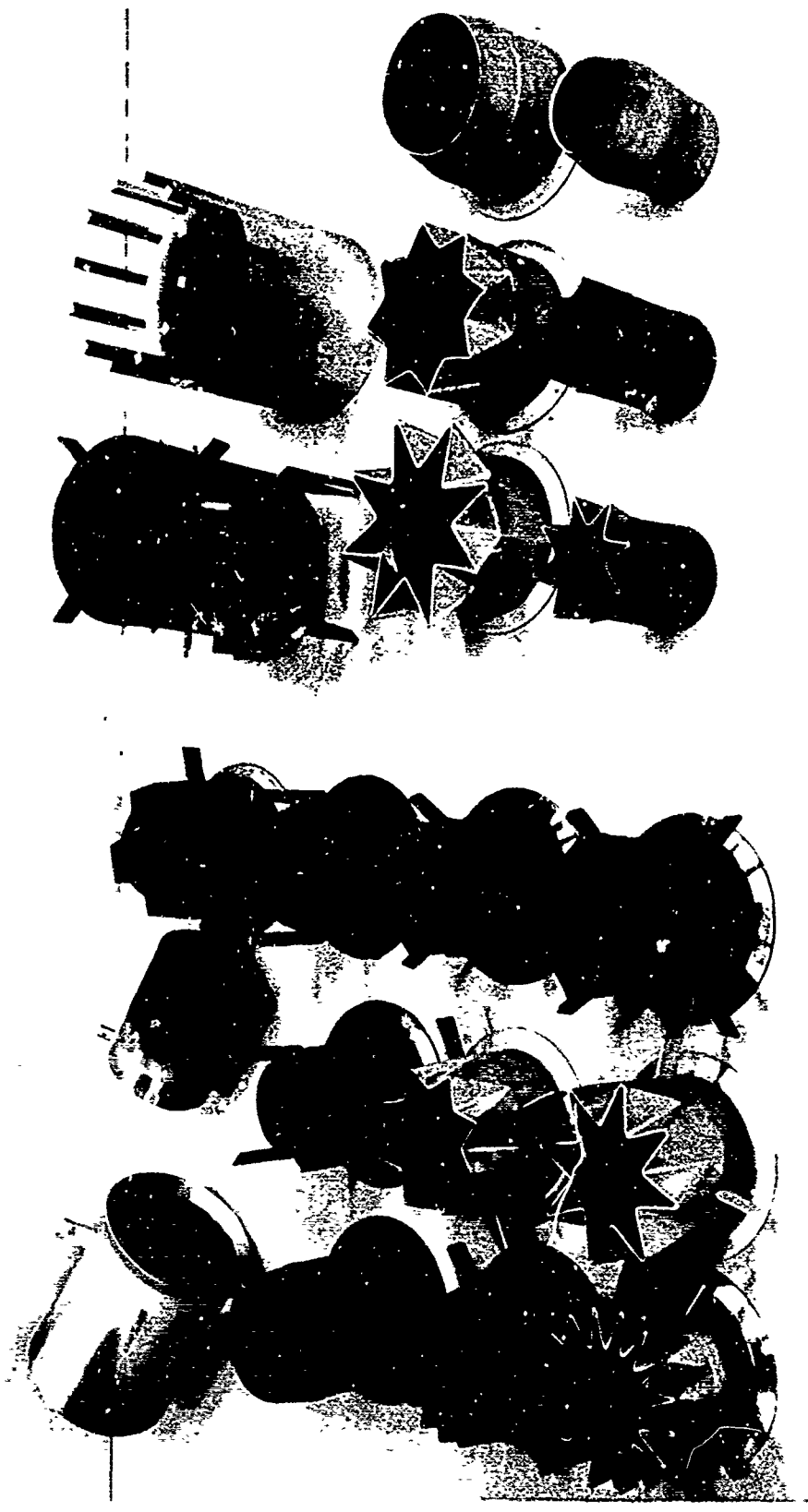


Figure 83. Noise Suppressor Models

D6-18110-5

### III. Description of Technical Progress (continued)

#### 1309. Engine Coordination (continued)

On May 12 and 13, 1966, a meeting was held with GE at Evendale to discuss the Engine/Airframe Agreement. The format for the agreement was presented by Boeing and discussed in detail. Accord was reached on the format for the agreement.

On May 16 and 17, 1966, a meeting was held with P&WA at their Florida Research Center for the purpose of establishing the format for the Engine/Airframe Agreement format. Accord was also reached with P&WA on the format for the agreement.

#### 14. PRODUCT SUPPORT

In the current reporting period, three engineers, with extensive commercial airline experience, were added to the maintenance engineering staff. This addition brings the staff complement to a total of 10 highly qualified engineers with sufficient experience and skill-mix to assist in all aspects of design development. Formal procedures and formats have been developed to incorporate design requirements into the design, based on direct airline liaison and past experience. These procedures will be worked in concert with design requirements emanating from the formal maintenance analyses, to preclude duplication and conflict.

Other activities included trips as follows:

- (1) A team visited Continental Airlines on April 14, to discuss Spares and Product Support concepts for the SST.
- (2) On April 28, a trip was made to Edwards AFB, California, to attend a B-70 briefing by NAA at the invitation of the FAA.
- (3) On April 29, a trip was made to tour United's maintenance base and discuss United's maintenance and overhaul philosophy.
- (4) During the week of May 23 to 27, a trip was made to American Airlines, Tulsa, to assist in the development of the model specification.

#### 1401. Data and Handbooks

##### Preliminary Flight Crew Operating Procedures

Preliminary flight crew operating procedures are being prepared by a working committee consisting of Technical Publications, Crew Accommodations, Human Engineering, and Flight Test personnel. The procedures identify responsibilities assigned to each crew member; i.e., captain, first officer, and engineer, by system breakdown. All operational phases; i.e., "Preflight," "Engine Start/Taxi," "Takeoff/Climb/Cruise/Descend," "Land/Taxi/Park," are being covered. Schematic diagrams for system flow, panel, and cockpit illustrations will accompany

D6-18110-5

### III. Description of Technical Progress (continued)

#### 1401. Data and Handbooks (continued)

the procedures, as applicable. System descriptions and procedures have been completed for the following:

Air Conditioning and Pressurization System

Electrical System

Main Hydraulic System

The engine and inlet controls are in preparation. Continuous updating will be required for each system throughout engineering development.

#### Technical Publications Specifications

Technical publications specifications are being prepared by the Publications Group. These specifications will be used during the preparation of the following preliminary and formal publications for prototype and production aircraft, respectively:

FAA Approved Airplane Flight Manual

Operations Manual

Maintenance Manuals

Any deviations required to ATA Specification 100 will also be prepared and presented with the specifications.

Upon completion of the specifications and deviations, it is desirable that rough draft copies be coordinated with certain major airlines; e.g., TWA, UAL, AA, and PAA. Each airline is being contacted during the week of 23 May 1966 to determine their interest in reviewing the specifications and deviations prior to finalization.

#### 1402. Spares

A provisioning team, composed of representatives from Engineering, Materiel, Production Engineering, Field Operations, Quality Control, Spares, and other affected organizations have been reviewing, during regularly scheduled meetings, the airplane and systems to define Phase III flight test support requirements and select spare parts for lay-in.

#### 1403. Training and Training Equipment

##### Training Analyses

A system analysis team was established for the purpose of participating in the determination and documentation of the SST training and training equipment requirements. Data that will be required

### III. Description of Technical Progress (continued)

#### 1403. Training and Training Equipment (continued)

for flight training simulator development were identified and procedures that will ensure timely availability of simulator developmental data were drafted.

A study was performed to analyze job titles, work practices, and work distribution in commercial aviation operations and maintenance organizations. Resultant data were prepared for use in parts of the system analysis process related to personnel and training. Current Federal Aviation Regulations were reviewed for applicability to SST training. Meetings were held with the Boeing Industrial Relations and Industrial Engineering Departments to discuss job titles, work practices, and related activities for personnel who will maintain and otherwise support the flight test programs.

#### Planning

The SST Engineering Flight Simulator and the SST Continuous Flight Simulator were reviewed to identify their potential use for pilot training for the prototype airplane. Computer storage and iteration frequency requirements caused by SST flight characteristics and display problems were studied.

Meetings were conducted to discuss and plan use of latest programmed learning techniques in the SST activities. Meetings were held with Flight Test Engineering and Flight Training Groups to prepare procedures for flight personnel training plan preparation.

#### Trips

Three members of the Training and Training Equipment Group visited Trans World Airlines, Pan American Airlines, American Airlines, and United Air Lines to discuss SST training and training equipment requirements.

#### 1404. Ground Support Equipment

##### 14040. GROUND SUPPORT EQUIPMENT GENERAL

From analysis of the SST and its subsystems a GSE list with program planning information has been developed and released as a document for internal coordination of requirements. This document contains a list of required standard and special GSE; estimated quantities required for Phase III, IV, and V; descriptions; work breakdown structure item numbers; and possible suppliers' names, to serve as the basis for GSE cost estimating and requirements definition. A ground support equipment requirements document is being prepared based on the GSE list, with requirements analysis sheets being drawn up for all standard and special GSE.

### III. Description of Technical Progress (continued)

#### 14040. Ground Support Equipment General (continued)

A "General Performance and Test Requirements Specification for SST Ground Support Equipment" has been released. This specification documents the general performance, design and test requirements applicable to all special GSE item performance specifications. Performance specifications for major items of special, mechanical and electronic GSE are currently in development.

#### 14041. SERVICE GROUND SUPPORT EQUIPMENT

An initial engineering analysis of the airplane ground handling and service requirements was completed in order to define the Service GSE to be entered in the GSE list. This analysis is continuing, to provide detail definition of requirements based on the latest configuration.

#### 14042. MAINTENANCE GROUND SUPPORT EQUIPMENT

Methods of installation and removal of the engine inlet have been investigated and it currently appears that a "bootstrap" method similar to that used for the basic engine change can be employed.

Engineering studies are being conducted to develop optimum methods of removal/replacement for various components such as accessory drive system, control surfaces, control surface actuators and wing pivot bearings and plug. A general usage type platform incorporating hoists is being considered which could be employed during component removal/replacement or for on-board maintenance of items such as engines, inlets, control surfaces, actuators or wing pivot bearing. Work has continued on ground handling of the airplane, including towing and jacking. A jacking concept has been worked out which employs three main jacks for raising the airframe while performing maintenance on items such as the landing gear. Additional stabilizing jacks, one at each wing tip are utilized when performing maintenance on the wing pivot bearing.

A preliminary analysis of the SST was completed to define the Maintenance GSE requirements to be entered in the GSE list.

#### 14051. AIRLINE SUPPORT FACILITIES

Evaluation is continuing of updated aircraft configurations regarding suitability with airfield pavements, passenger loading devices, and ground maneuvering. To the extent that data is becoming available regarding foreign airport pavements, these are also being evaluated to ensure compatibility. A scale model of the current configuration has been made up to assist in demonstrating rolling turn capability on turns with standard fillet radii.

#### IV. AIRLINE COORDINATION

A meeting with the Airline SST Specialist Team on Electrical Systems was held on April 19 and 20. Additional Specialist Team Meetings are scheduled for June.

A comprehensive Specification Review was conducted with Qantas at their Engineering Base at Sydney, Australia on May 9 through May 13.

A series of proposal configuration briefings were conducted for the management of AAL, EAL, PAA TWA and UAL at New York and San Francisco on May 20, 24 and 25.

Personnel from the following airlines were given mockup tours and technical briefings:

United Air Lines, Inc.	Trans World Airlines, Inc.
American Airlines, Inc.	Northwest Airlines, Inc.
Irish International	Deutsche Lufthansa A. G.
Pan American World Airways	New Zealand National Airways

A copy of the Airline Coordination Record pertaining to the Irish International follows.



AIRLINE COORDINATION RECORD

cc: S. N. Weiner  
W. C. Becker  
H. L. Adams  
A. Burdo  
E. J. Osolt  
R. Sawhill

AIRLINE: Irish International Airlines DATE: 4/18/66

HELD AT: Boeing Developmental Center - Seattle

PARTICIPANTS: <u>Captain Peter Little</u>	<u>Boeing</u>
<u>Captain C. Smith</u>	<u>S. N. Weiner</u>
<u>Dermat Walls - Resident Representative</u>	

GENERAL:

received general airplane and program updating and mockup tour.

SPECIFIC COMMENTS BY AIRLINE:

1. Requested information on the requirement for crew use of oxygen during normal cruise on SST.
2. Asked about highest temperature of fuel within any tank.
3. Suggested vertical "g" meter be installed in flight deck to advise flight and ground crews of magnitude of turbulent air and hard landing loads.
4. Questioned whether life of 100 hours at 166 db was satisfactory for aft body structure.

BOEING POSITION ON AIRLINE COMMENTS:

1. Were advised that use of crew oxygen during normal cruise was considered unnecessary if quick donning mask was readily available to each pilot. This item will be reviewed with regulatory branch of FAA.
2. Were advised that trapped fuel could reach temperature of 180°F. Temperature of useable fuel within tank will not exceed 125°F.
3. Recognized time problem in obtaining flight recorder data. Will review merits of such instrument.
4. Were advised 166 db is design point representing sound level considerable above that resulting from maximum dry takeoff power. Considering this and that the highest noise level exists for approximately 15 seconds only on takeoff, the design life objective is considered satisfactory.

D6-18110-5

## V. RELATED BOEING RESEARCH AND DEVELOPMENT

### A. PROCESS DEVELOPMENT

#### Diffusion Welding and Brazing

Shear strength results from Ti-6Al-4V specimens that were copper plated prior to diffusion brazing were similar to those that were brazed with copper foil.

Small voids in diffusion welded Ti-6Al-4V, with and without zirconium foil at the interface, had no appreciable effect on the joint static shear strength. The voids were not detected by ultrasonic inspection.

Table G shows the shear strengths and process parameters for Ti-6Al-4V specimens copper plated on one faying surface, specimens with a zirconium foil interface, and specimens with no interface material.

A preliminary specification, BAC 5960, "Copper Diffusion Brazing of Ti-6Al-4V," has been released.

#### Conventional Brazing

Bent beam Ti-6Al-4V lap joints brazed with Ti, V and Ti-32V were exposed for six weeks to alternate room temperature salt spray and 550°F without failure. Metallurgical examination of the brazed joint cross section showed no evidence of corrosive attack or corrosion products.

### B. MANUFACTURING DEVELOPMENT

#### Elevated and Room Temperature Sheet Metal Forming




Aero-Cal Metal Fabricators of Los Angeles work on a cold compression section rolling process has been authorized. Necessary tooling is being fabricated and test material is being shipped from Boeing. Start of tooling is scheduled for the second week in June.

Hot and cold joggling tools on Ti-6Al-4V annealed brake formed sections have been completed. Manufacturing limits for cold material in gages up to .063 have been established. Hot testing indicates that limits of joggle depths for various material gages are determined by press capacity and tool material capability.

#### Welding

A joint development program between Boeing and the Linde Division of Union Carbide Corp. has been conducted on plasma arc welding to Ti-6Al-4V. Welding techniques and schedules were developed for welding 0.500 inch thick plate, in one pass, using a square butt edge preparation. Visual and radiographic inspection of all welded test plates indicate that excellent weld quality with no measurable porosity was obtained. Static and fatigue specimens are being fabricated for determining joint ductility and fatigue life.

Table G. Shear Strengths in Diffusion Welded and Brazed Ti-6Al-4V

Interface Material	Shear Strength (ksi) 	Temperature (°F)	Pressure (psi)	Time (min.)
Copper	74 (failed outside bond)	1900	15	60
Copper	79	1900	15	60
Copper	81	1900	15	60
Zirconium	82	1900	15	60
Zirconium	84	1900	15	60
None	80	1900	15	60
None	84	1900	15	60
Copper	73 	1800°F	15	15
Copper	75 	1800°F	15	15



Ultrasonics showed poor bond areas



Based on 3/8-inch overlap, 1/2-inch wide specimen (3/16-square inch shear area)

V. Related Boeing Research and Development (continued)

B. Manufacturing Development (continued)

A technique was developed to fusion weld long butt joints in thin titanium sheet. Commercially pure titanium panels .040 gage by 6" x 240" were successfully welded by the gas tungsten arc process. Waviness in the panels, resulting from the welding stresses, was reduced from 0.15 to 0.50 inch high frequency amplitude deflection to gradual deflections of 0.018 to 0.045 inch by cold roll planishing. Porosity (from x-ray data) ranged from 0.002 to 0.012 inch in diameter.

Factory checkout of a new Sciaky numerically-controlled spot welder has been completed. The machine complied to manufacturing requirements, meeting the intent of the Boeing specification. Shipment to Boeing is scheduled for June 6.

Test samples of sine wave (corrugated) web structure were successfully machine welded using the gas tungsten-arc process and a magnetic tracing device. The melt-through technique, with no filler wire addition, was used. Good quality welds with adequate underbead fillets were obtained. Radiographic inspection indicates minimum porosity is present.

C. RELATED BOEING FUNDED DEVELOPMENT HARDWARE

Sketch No. 31

Creep forming of a 3 x 30-foot sculptured and tapered wing skin in an integrally heated matched ceramic die was basically successful. Two localized areas had deviation from contour of approximately 1/2 inch. This was due to an uneven temperature gradient in the corresponding area of the die during cooldown. It is being corrected by refinements of the dies electrical temperature controllers, installation of an air cooling system, and rework of the die peripheral edge heaters. The part will then be re-cycled.

Sketch No. 32R1

Processing being exercised to form a 30 x 36-foot Ti-6Al-4V lower inboard wing skin is: surface to 0.7 thickness, cold form to contour, stress relieve, and chemical mill to specified drawing dimensions. A localized hot size operation may be necessary to form the part in two areas.

Sketch No. 34

Seventy-eight percent of the details for the 110-inch long leading edge slat assembly are complete. Significant progress has been made in welding, stress relieving and hot sizing the aft slat spar assembly. This is a weldment composed of 29 different details. It is currently being machined to the inner skin mold line preparatory to the honeycomb core bonding sequence. With the exception of two bonding fixtures all tools required are complete.

V. Related Boeing Research and Development (continued)

C. Related Boeing Funded Development Hardware (continued)

Sketch No. 36

All details for the wing strake body attachment assembly are complete except for the body frames. These are being final contoured. Completed subassemblies include two skin-stringer panels and the bulk-head including the attachment fitting. Assembly completion is scheduled for July.

Sketch No. 38

The 60 x 200-inch strake panel has been successfully bonded. It requires post curing and trimming to complete. Expected completion is the first week in June.

D. MATERIAL DEVELOPMENT

The following is a description of SST related research covering material development.

Transparencies

Purchase orders for test windshields have been placed with two companies, Libbey-Owens-Ford and Goodyear Aerospace. Delivery is expected on the required schedule of November 1, 1966.

Polyimide Honeycomb

Preliminary specification 8-125 was sent to two potential suppliers and replies have been received from both and forwarded to the Material Technology Staff. Meetings were held with Hexcel on April 12, 1966, and May 18, 1966, in which both polyimide and titanium core were discussed.

Hexcel, during their May 10, 1966 meeting submitted a sample of diffusion bonded titanium core which looks very promising. The core is now being tested and results should be known around June 1, 1966.

Hydraulic Fluid

Humble Oil has submitted a sample of a new fluid; namely, WSX68-85, which they feel has an improvement in oxidative stability over their 52-51 fluid. Also, Castrol has submitted a new fluid; namely, B88 BY/64 which they predict to be more thermally and oxidatively stable than the B/64 fluid. Tests have begun and the results should be complete by early June.

Dow Corning has a fluid in contention for SST requirements; however, improvements must be made in the bulk modulus and density. They are constantly working on these problem areas and more data is expected in the near future. Monsanto has submitted samples of their MCS 4542 fluid and tests are now being run.

D6-18110-5

## V. Related Boeing Research and Development (continued)

### D. Material Development (continued)

The preliminary specification for the hydraulic fluid is scheduled for release in early June. Industry will be requested to respond by July 1, 1966.

#### Adhesives

Continuing efforts are being made to qualify Bloomingdale's FM-34 adhesive to XBMS 5-53. It is anticipated that specification approval will now be accomplished no later than November, 1966 due to the long aging tests involved. Bloomingdale is close to qualifying as a supplier; however, tests are constantly being run on DuPont, Narmco and 3M material to broaden the source base. Preliminary results indicate that DuPont may qualify as a second source to this specification.

#### Diffusion Bonding - Titanium Honeycomb

Northrop has predicted production airplane costs ranging from a low of \$500 a square foot for flat panels to a high of \$2,000 a square foot for complex double-curvature; with an average of approximately \$800 per square foot. This compares to an estimated cost of under \$100 per square foot for polyimide fiberglass honeycomb. The high panel cost of diffusion bonding makes this process questionable in production.

#### Diffusion Bonding - Integral Stiffeners

The North American proposal for a diffusion bonding study of integral skin stiffeners for the wing structure is still being reviewed.

#### Projected Pricing - Titanium Raw Material

Pre-pricing inquiries have been released to all major titanium sources for the purpose of establishing forward pricing on all mill products.

This information will assist the major subcontractors in their pricing effort and provide information in advance of the release of firm bill of materials.

#### Extrusions

All Phase II-C extrusion orders have been completed with the exception of several remake items. All suppliers have experienced a moderate rejection rate and continuous follow-up is being maintained to ensure meeting remake schedule commitments. A noticeably high recovery rate was obtained by Harvey Aluminum in their initial production of titanium extrusions to the XBMS 7-44B specification. This excess over purchase order requirements was purchased to support additional test requirements.

## V. Related Boeing Research and Development (continued)

### D. Material Development (continued)

#### Sheet and Plate

A limited number of program orders remain open with Reactive Metals. These are scheduled for completion during early June, 1966. This period will also signify the commencement of delivery for major program requirements from Titanium Metals Corporation of America.

A meeting was held with TMCA's West Coast Representative on May 12, 1966 to discuss production and schedule problems relating to current orders. As a result TMCA was requested to review their present position and to ensure they have sufficient visibility to meet existing schedule commitments.

#### Bladder Fuel Cell Development - P/N 10-60970

Start of cube cell testing by U.S. Rubber has been further delayed. Additional pull tests have been accomplished in order to obtain data on strength differences between bladder cell material and their improved fitting biscuit buildup. Fabrication of their test cube cell is currently scheduled for completion on 6-1-66.

Goodyear has completed cube cell fabrication. Flight pattern cycle testing of the first 1000 cycles commenced on May 13, 1966.

#### Oversized Titanium Plate

A purchase order has been awarded to Titanium Metals Corporation of America for five (5) titanium plates .250" x 72" x 500" in the solution treated and aged condition. Titanium Metals Corporation of America will use Bethlehem Steel Co., located at Burns Harbor, Indiana, for the rolling operation. Coordination is now in process to enable Boeing personnel to witness initial rolling processes at the Bethlehem facility. Delivery will be completed by September of this year.

#### Net Extrusions

H. M. Harper Company has been awarded an order to provide net extrusion to Class A tolerances. This program will demonstrate industry capability in producing extrusion requiring little or no machining. Delivery is expected during early June 1966.

#### Tapered Extrusion Development

A development program for a tapered extrusion has been awarded to Nuclear Metals of West Concord, Massachusetts. Initial parts will be available for evaluation by mid-June 1966.

#### Hot Size Dies

A source survey was conducted to ascertain if there is sufficient capability and capacity to cast hot sizing dies, using the modified Shaw or similar process. Results of the survey revealed that the four sources visited are very interested in performing this type of work and, assuming the R & D process is successful, they would have adequate capacity to meet requirements.

D6-18110-5

## V. Related Boeing Research and Development (continued)

### D. Material Development (continued)

Orders have been placed with Waukesha Foundry for the casting of 10 die sets under production conditions. An order has also been placed with IIT Research Institute to monitor and evaluate this program. Pouring of the first lot of castings is anticipated by early June.

### E. AERODYNAMICS DEVELOPMENT

Wind tunnel tests were run to determine the effects of strake leading-edge blowing boundary-layer-control (ELC). The tests covered Mach numbers 0.3, 0.4, and 0.5 for a 30-degree swept wing with strake and a 50-degree swept horizontal tail. No trailing-edge flaps were used. The strake leading-edge was equipped with a continuous slot nozzle of 0.01 inch width to provide blowing from three separately controlled plenums on each side of the wing for spanwise blowing variation. Model and leading edge configurations are indicated in Figs. 84 and 85.

It was found that the blowing ELC reduced the wing downwash at the tail, improving the tail effectiveness. Blowing quantities required to maintain favorable pitching moments were mainly a function of how well strake and outboard leading-edges were protected with flaps.

With full span optimized leading-edge flaps, strake leading-edge blowing quantities required were minimum and resulted in essentially linear pitching moments up to the test limit of 27.5-degree angle-of-attack. Three vertical positions of the horizontal tail were run with similar results.

In the absence of the strake leading edge flap, strake blowing quantities had to be increased to match the stability of the full span leading-edge flap configuration. Pitchup appeared at 26-degree angle-of-attack.

Oil flow pictures of the outboard wing suggest outboard leading-edge blowing for further improvements.

Representative results are shown in Figs. 86, 87, and 88.

### F. ELECTRICAL DEVELOPMENT

#### Corona Tests

Tests are being run to establish the corona onset and extinction voltages for various SST twisted-pair wire samples of 20 AWG. Values are being determined between 25°C (77°F) to 260°C (500°F) and from 1 to 150 torr. Report of results is scheduled for early June.

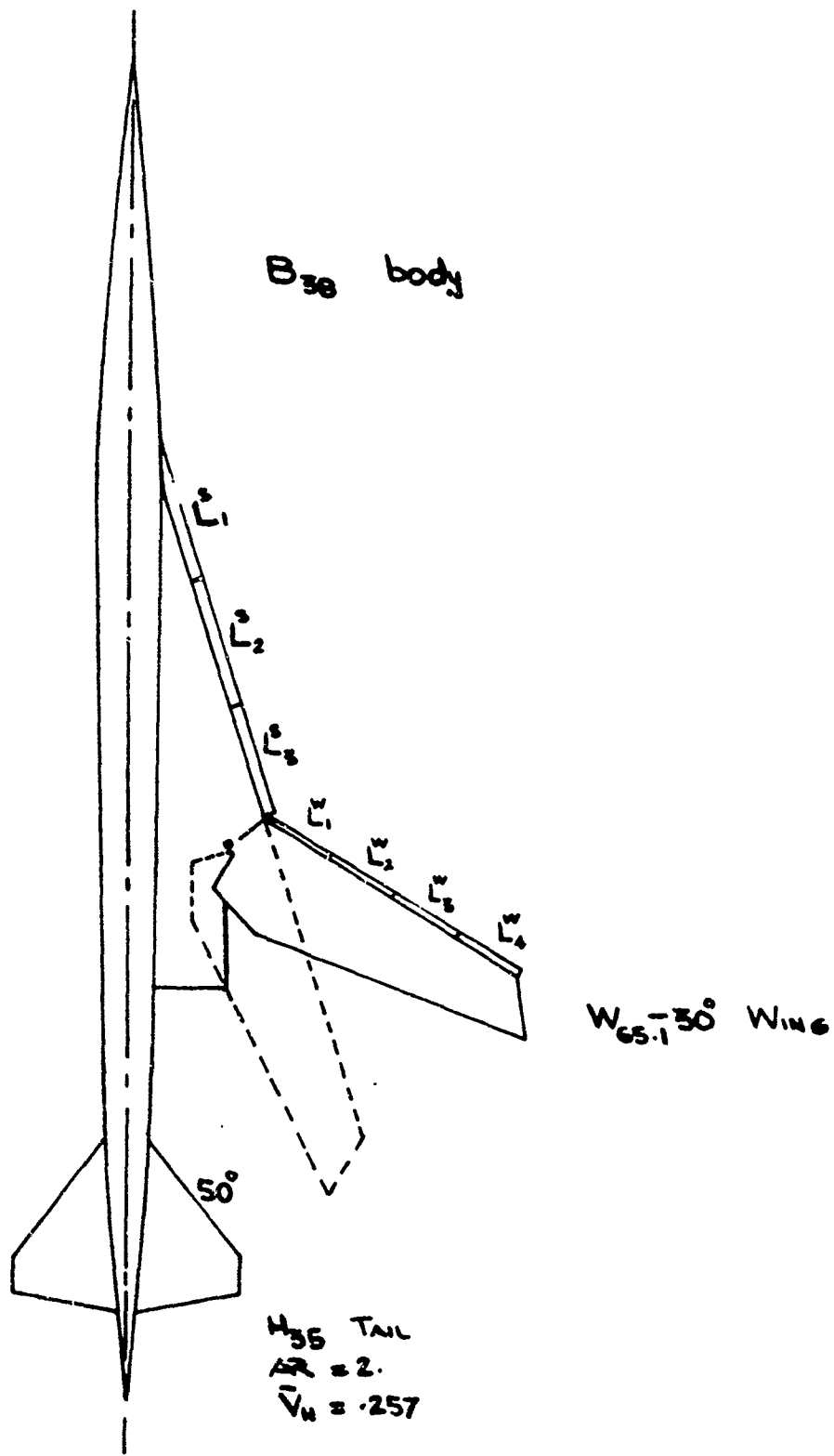
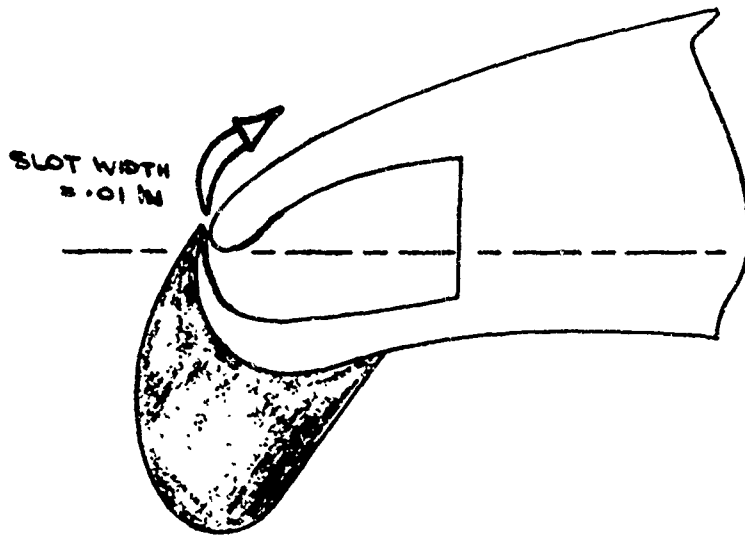


Figure 84. Wind Tunnel Model Platform

D6-18110-5



TYP. STRAKE L-E FLAP  
SECTIONAL VIEW

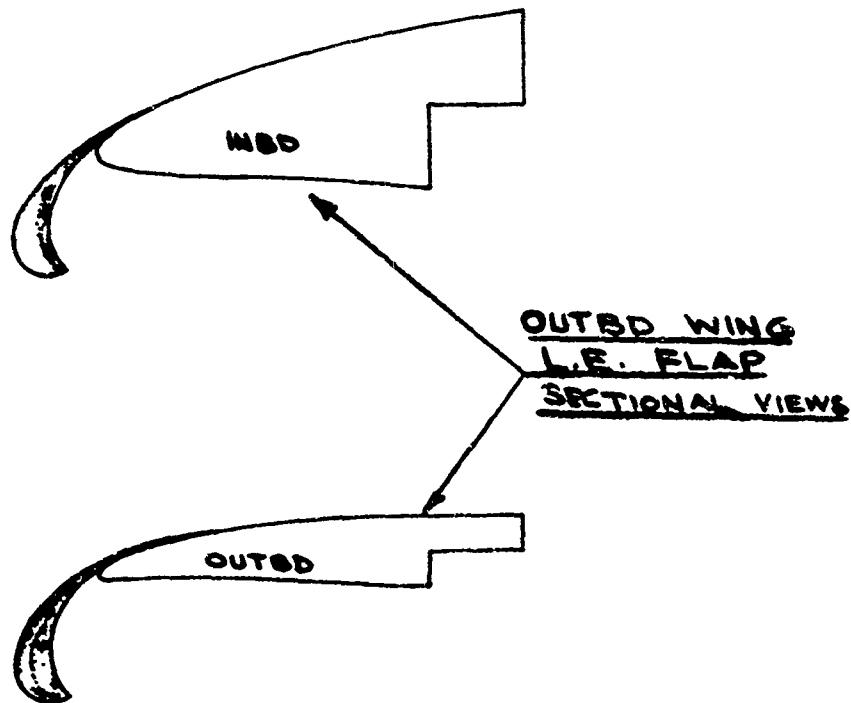
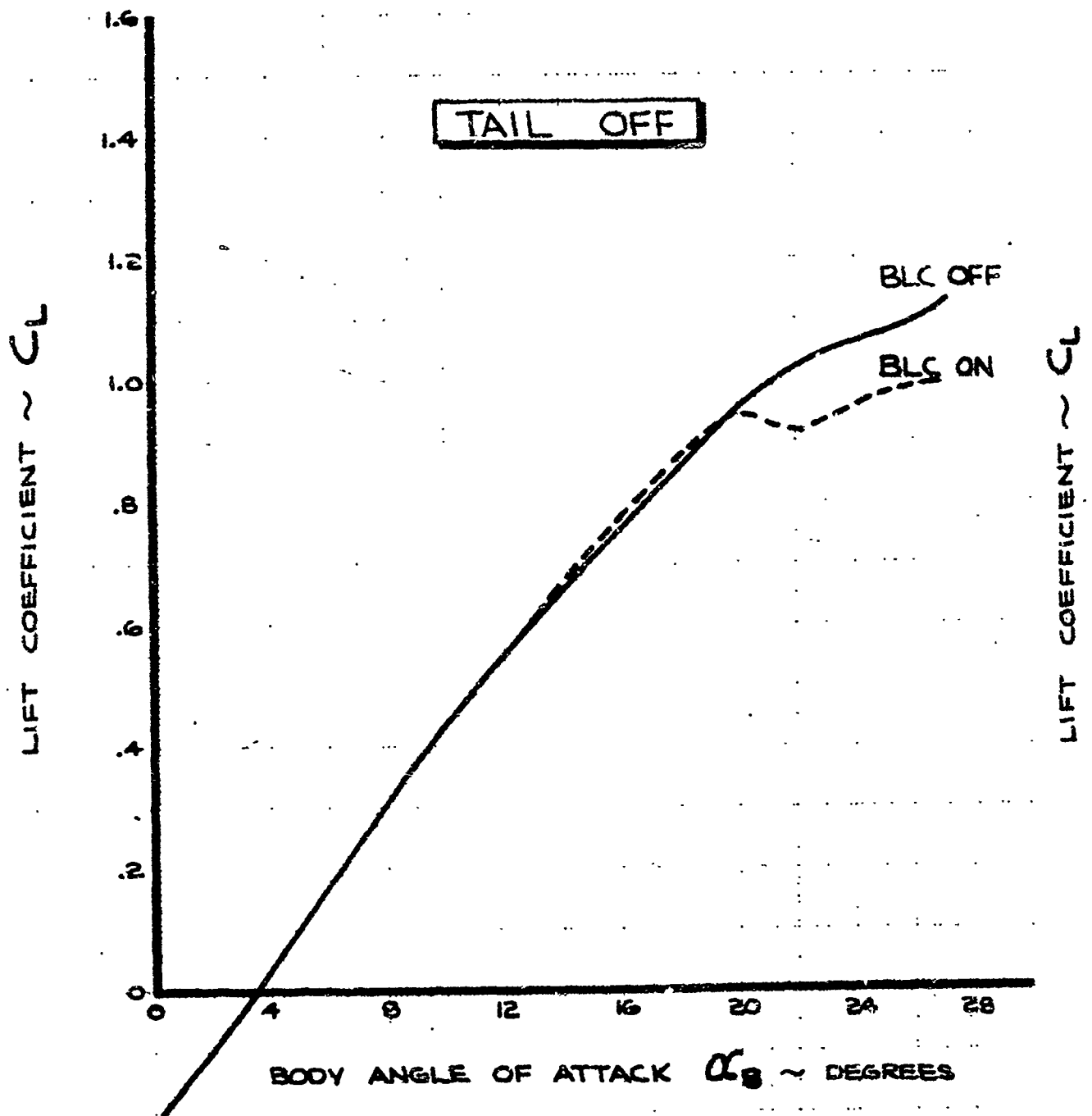


Figure 85. Leading Edge Flap Geometry

D6-18110-5

NOTES:

- 1. MACH NO. = .30
- 2. BLC AT STRAKE L.E.,
- 3. LEADING-EDGE FLAPS ON
- 4. OUTER WING SWEEP = 30°



A

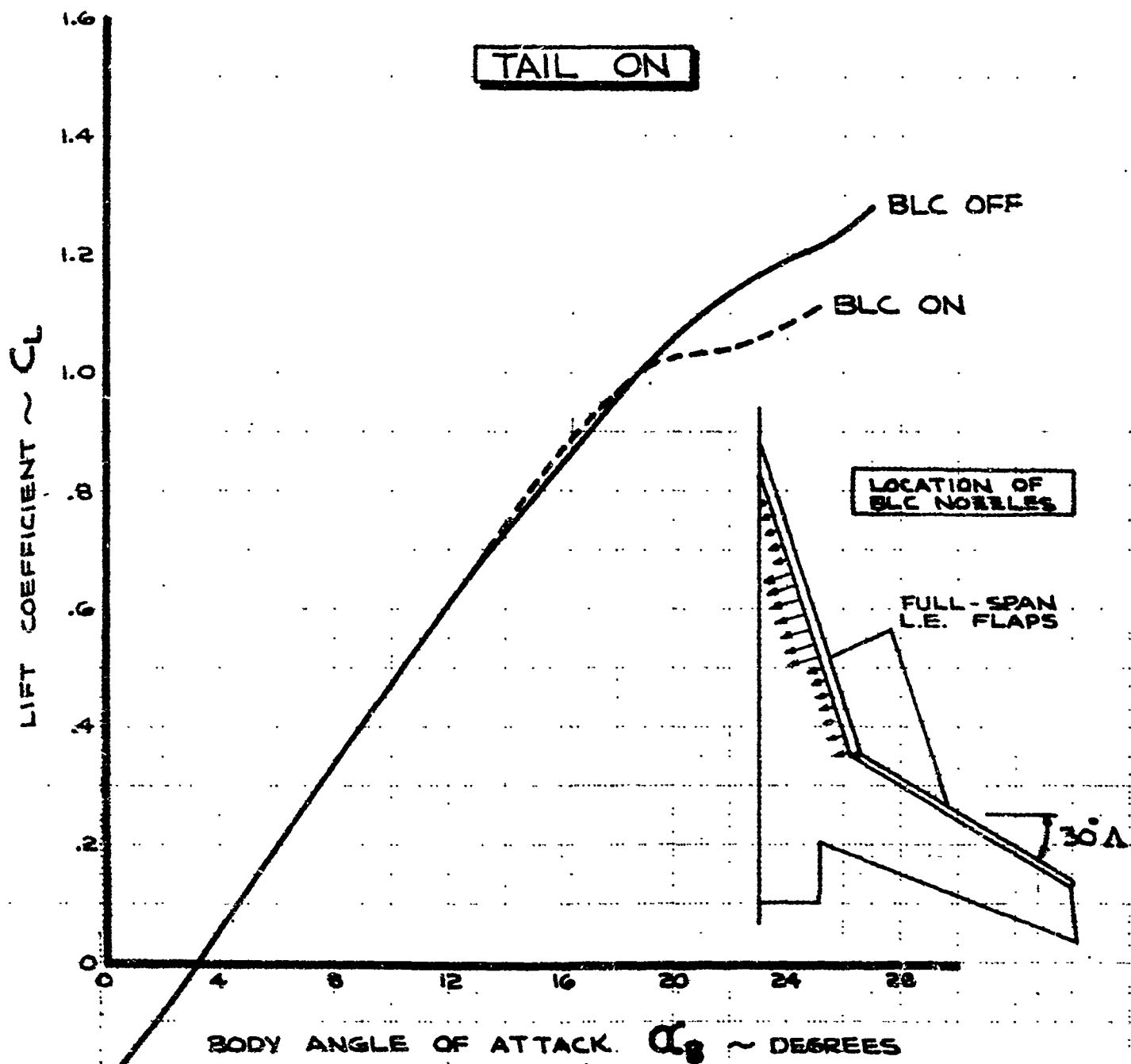
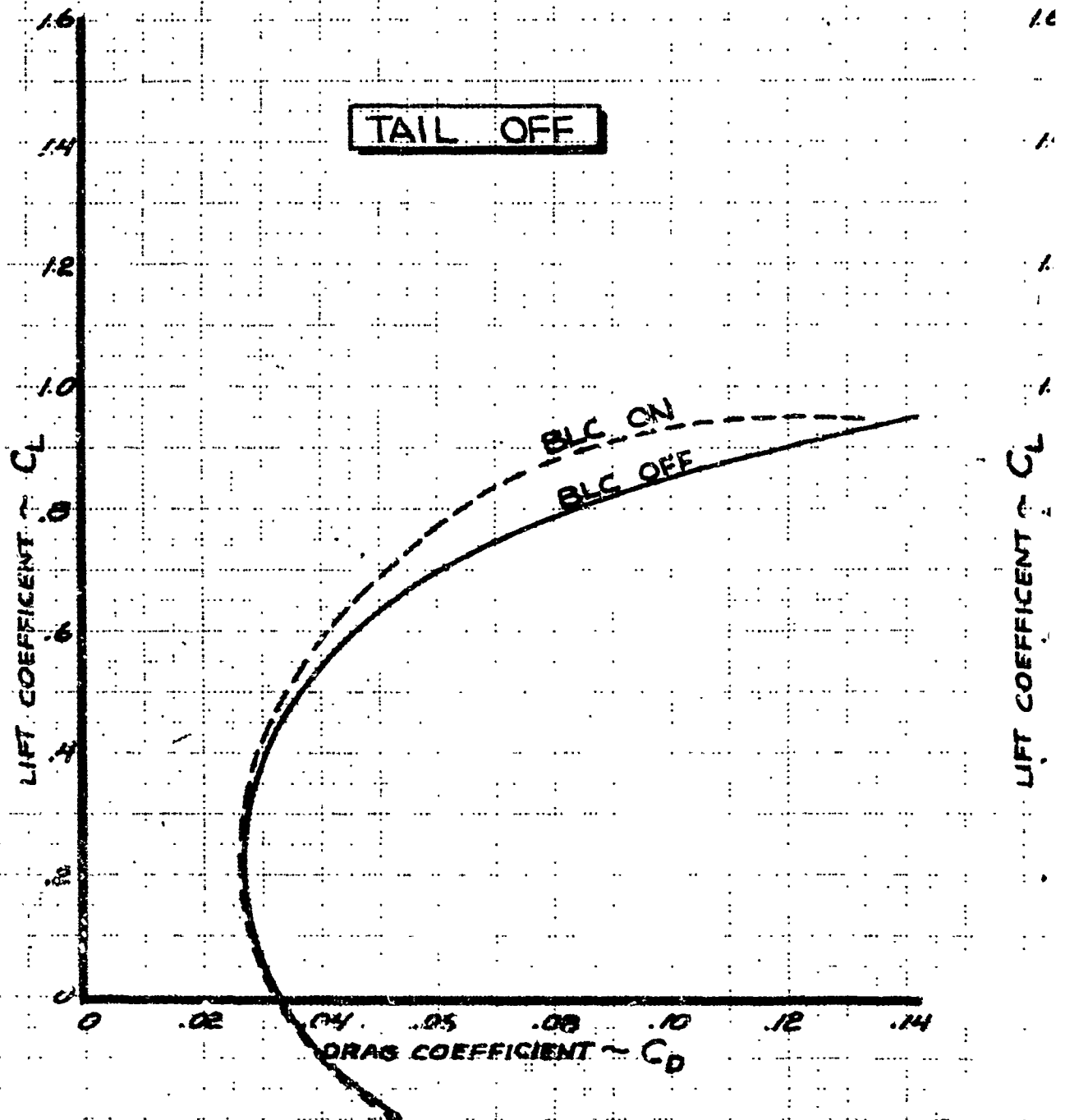


Figure 86. Effect Of Blowing BLC At Strake Leading-Edge On Lift

NOTES :

1. MACH NO. = .30
2. BLC AT STRAKE L.E.
3. LEADING-EDGE FLAPS ON
4. OUTER WING SWEEP = 30°



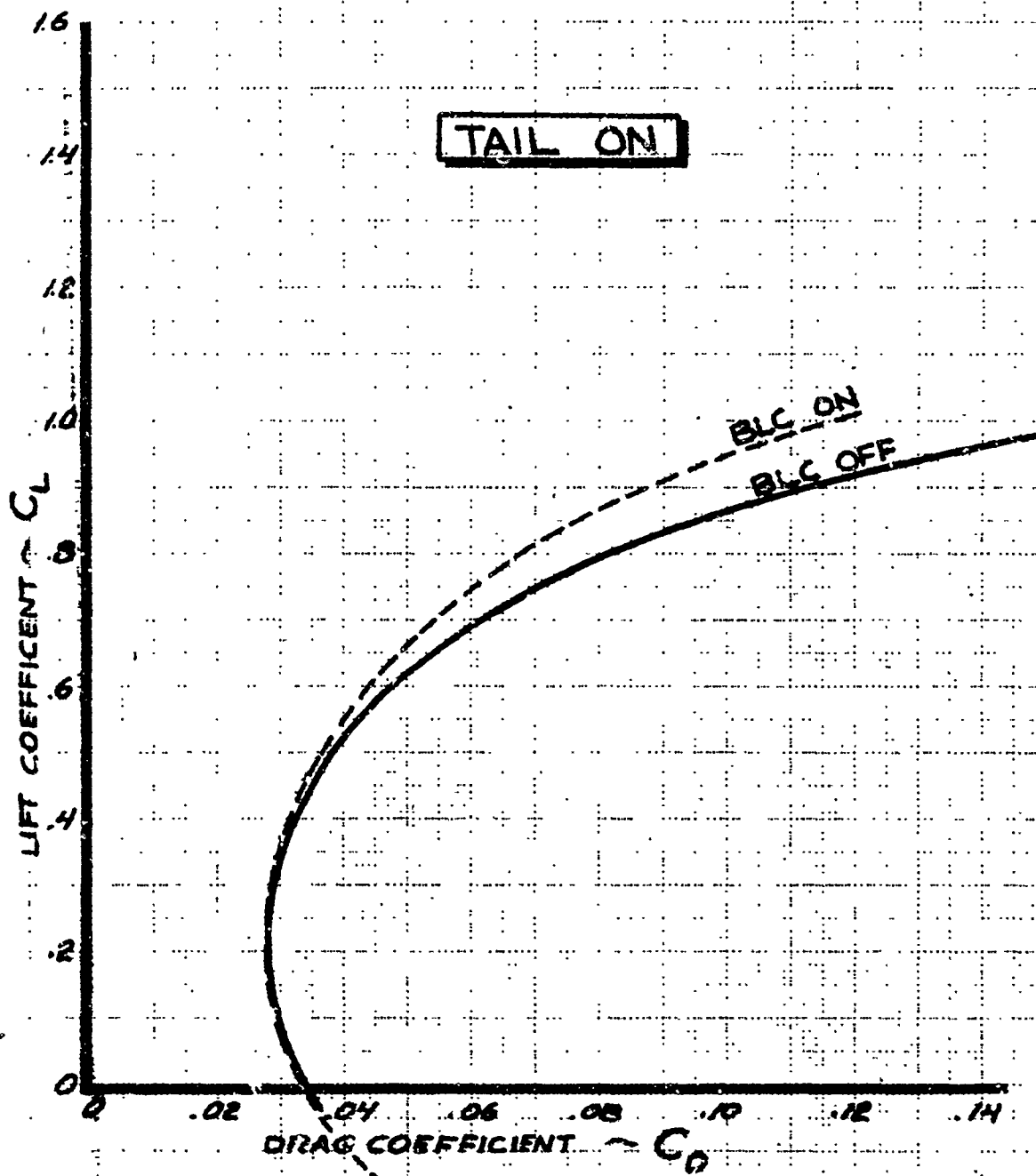
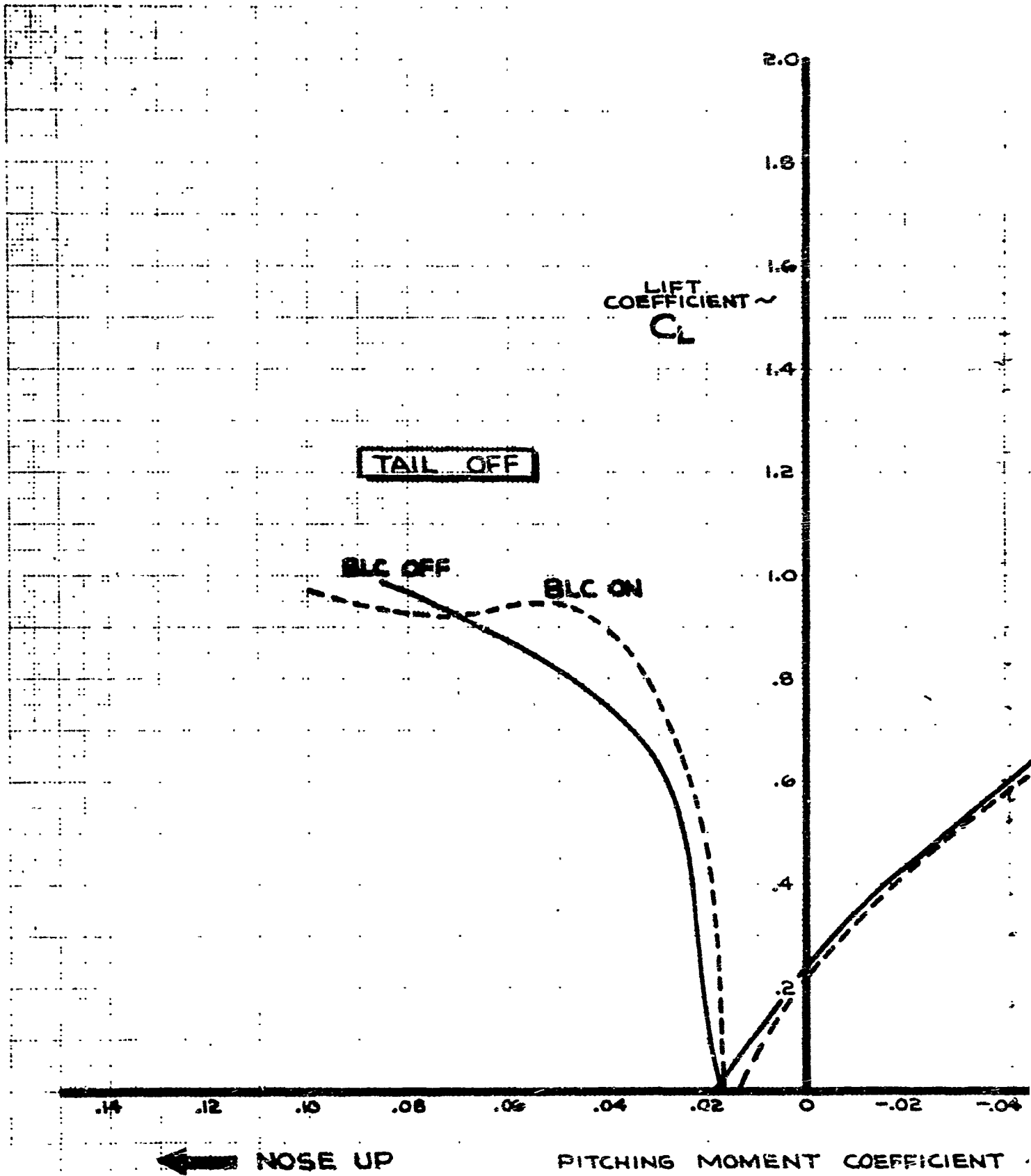


Figure 87. Effect Of Slowing BLC At Strake Leading-Edge On Drag



A

NOTES :

- 1. MACH NO. = .30
- 2. L.E. FLAPS ON. (FULL-SPAN)
- 3. BLC AT STRAKE / L.E.
- 4. OUTBOARD WING SWEEP = 30°

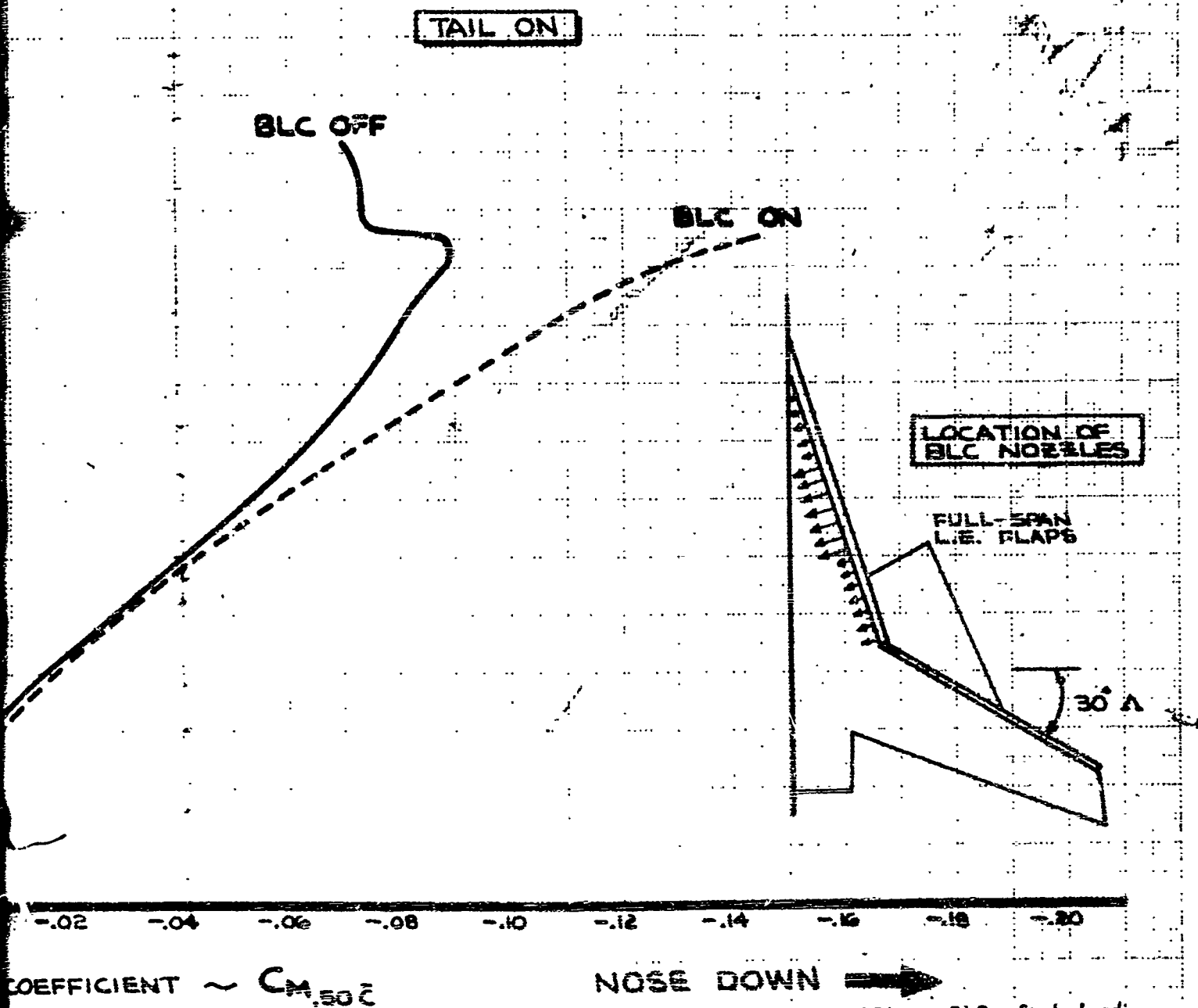


Figure 88. Effect of Blowing BLC at Strake Leading-Edge on Pitching Moment

V. Related Boeing Research and Development (continued)

F. Electrical Development (continued)

Thermal Aging, Life, and Cut-Through Tests

U.S. Marine Engineering Lab., Annapolis, Maryland, reported the following: DuPont 20 AWG samples 99A and 99B insulated with H-film have completed the following thermal aging/life tests to May 16, 1966 without failure:

Time (Hours)	Temperature
1512	260°C (500°F)
1344	280°C (536°F)
672	300°C (572°F)
408	320°C (608°F)

Also thermal cut-through tests being run continuously at 320°C (608°F) have produced no failures for 800 hours on samples DuPont 99A, 99B and Prestolite SST-1 and SST-2.

Electrical Systems

Five VSCF generation system shielded feeder configurations were tested. The results indicate that electromagnetic interference requirements may be attainable with only a single copper close-braid overall shield.