

UNCLASSIFIED

AD NUMBER
AD800592
NEW LIMITATION CHANGE
TO Approved for public release, distribution unlimited
FROM Distribution authorized to U.S. Gov't. agencies and their contractors; Administrative/Operational Use; SEP 1966. Other requests shall be referred to Department of the Army, Fort Detrick, Frederick, MD 21701.
AUTHORITY
Army Biological Defense Research Lab ltr dtd 28 Sep 1971

THIS PAGE IS UNCLASSIFIED

AD800592

DEPARTMENT OF THE ARMY
Fort Detrick
Frederick, Maryland 21701

TECHNICAL MANUSCRIPT 318

AN AUTOMATED METHOD FOR PERIOD
MEASUREMENT OF A TORSIONAL PENDULUM

Jesse L. Stup, Jr.

Munition Development Division
COMMODITY DEVELOPMENT AND ENGINEERING LABORATORY

Project 1B522301A030

September 1966

DISCLAIMER NOTICE

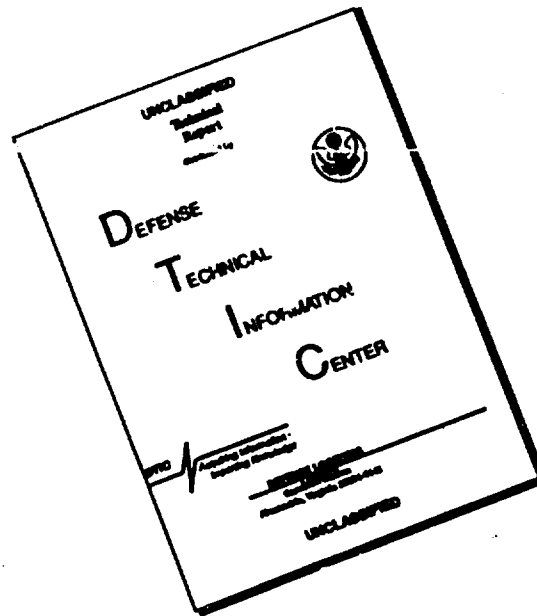

**THIS DOCUMENT IS BEST
QUALITY AVAILABLE. THE COPY
FURNISHED TO DTIC CONTAINED
A SIGNIFICANT NUMBER OF
PAGES WHICH DO NOT
REPRODUCE LEGIBLY.**

ACKNOWLEDGMENT

I wish to express my thanks to John Templeton for his assistance in circuit design, assembly, and testing.

ABSTRACT

A pulse recognition circuit has been devised that enables it, when used in conjunction with a digital counter and printer, to determine the period of a torsional pendulum even though the amplitude of the pendulum is variable and exceeds 360 degrees. This method is easier to use, saves time, and is more accurate than a mechanical-electro method previously used.

I. INTRODUCTION

When the period of a torsional pendulum system containing a body whose mass moment of inertia can be calculated is compared with the period of the same system containing a body of equal mass, but irregularly shaped, it is possible to determine the mass moment of inertia of the irregularly shaped body. This method has been used quite successfully by this agency for several years.

Although the period of the system should be unaffected by variation in the amplitude of the torsional pendulum under constant mass loading, slight discrepancies from period to period do occur because of bearing misalignment and bandwidth of the time sensing element (variation in time for the intensity of the light from the source to build up to trigger sensitivity of the sensing element). This error is minimized by averaging the results of several periods.

Until very recently, data were acquired by a combination of manual-electro-optical methods that allowed loss of data during the readout period. This report deals with a method by which all time periods can be recorded without losing data that may be significant.

II. THE TORSIONAL PENDULUM

The torsional pendulum consists of a platform suspended on a length of steel wire. The platform is free to rotate in a bearing; the other end of the wire is fixed. The body under study is placed on the platform (Fig. 1).

When a measurement is to be made, the pendulum is wound, usually three to five revolutions, and then released. Thus, the amplitude of rotation of the platform will range from a minimum of approximately 1,000 degrees to perhaps as much as 1,500 degrees depending on the tightness of the wind. Of course, the fixed end of the wire does not rotate. Consequently, the amplitude of rotation around the wire axis is constantly increasing as the distance from the fixed end to the platform end increases (Fig. 1). Likewise, the velocity of points at equal radii and perpendicular to the rotational axis increases as the distances of the planes of rotation from the fixed end increase.

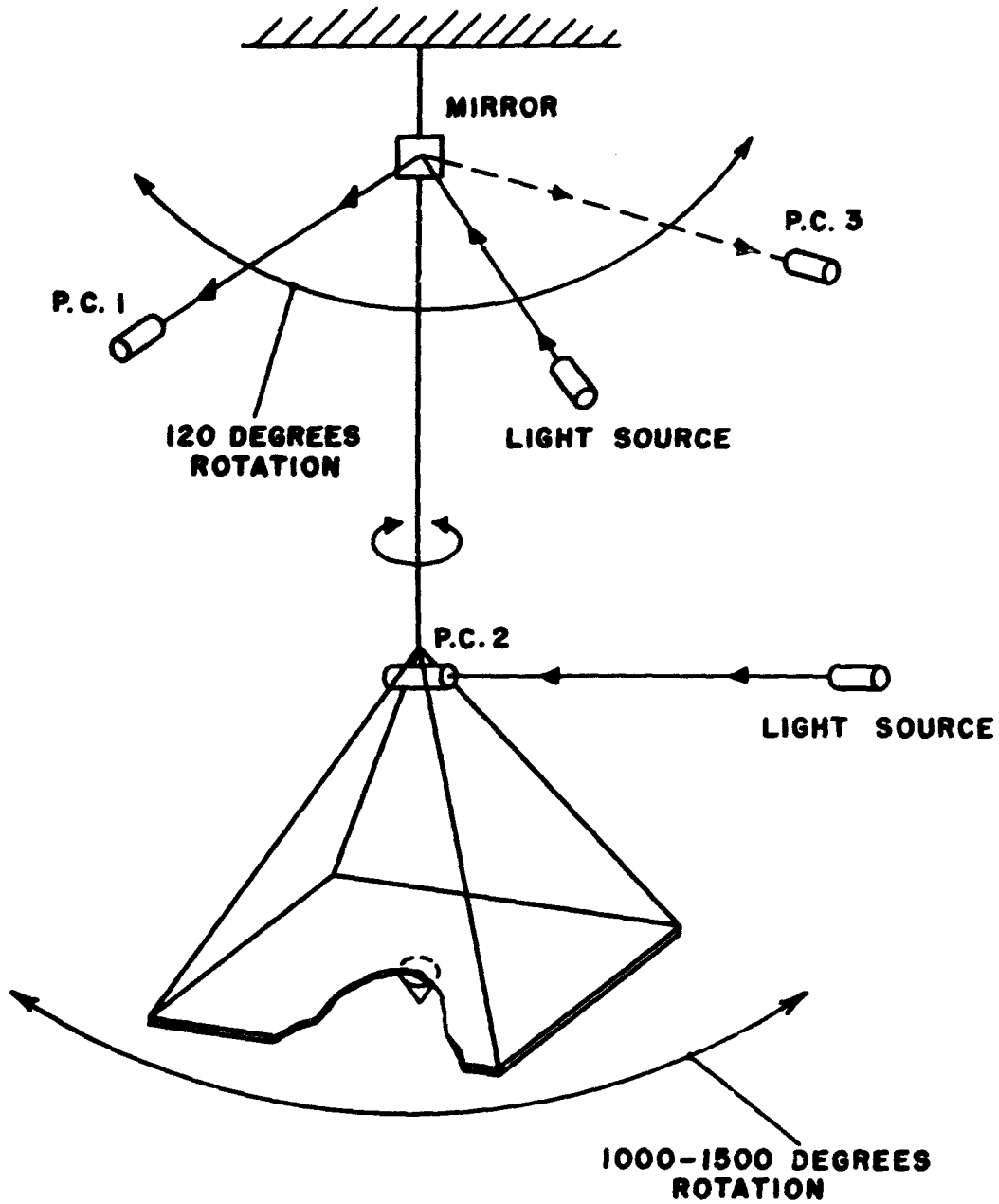

Figure 1. Arrangement of Trigger Sensitive Elements on Torsional Pendulum.

III. THE MEASUREMENT SYSTEM

Approximately 5 inches from the fixed end of the wire a mirror is attached to the wire. At this point, the angular rotation of the wire is approximately 120 degrees when the pendulum is normally wound. Two light-sensitive elements and a light source are placed in the plane of rotation at this point. These elements form a right angle to one another with the mirror at the apex. The light source is placed midway between the sensitive elements at nearly equal radius. The amplitude of rotation at this point is great enough to allow reflected light from the mirror to trigger either of the sensitive elements, which serve as parts of a logic circuit described later. Ideally, it would be desirable to place the light-sensitive elements at the peak amplitudes of the pendulum, but since the amplitudes are variable, the peak positions cannot be determined. Therefore, it is necessary to place the elements at positions less than peak to insure triggering. This causes two triggering pulses, one as the pendulum approaches the peak, the other as it leaves. The logic circuit must determine which pulse of light to accept. Furthermore, since the slopes of the light pulses to the sensing elements are not step inputs but rather functions of the velocity of the mirror, and since the mirror at this position is moving relatively slowly compared with a position on the platform, this position is not desirable as a time period pick-up.

The platform, which rotates at the highest velocity, is the most desirable location for placing the time period element because its velocity reduces the effect of the bandwidth of the light pulse and provides a more accurate period measurement. However, as mentioned above, the platform rotates several revolutions, an equal number in both clockwise and counter-clockwise directions, causing several triggering pulses per cycle as the sensing element passes the light source. To make a period measurement it is necessary for the platform to be exactly in the same position on successive cycles when the time pulse is accepted. A specific pulse out of many generated must be selected. This is achieved by the use of the circuit shown in Figure 2. P.C.1 and P.C.3 are mounted as described above near the fixed end of the wire. P.C.2 is mounted on the platform and a light source in the plane of rotation of P.C.2 is placed to trigger P.C.2. Q1 requires a positive pulse to turn it on and a negative pulse to turn it off. P.C.1 and P.C.3 provide these pulses respectively. P.C.2 provides the positive pulse to turn on Q2. However, Q2 cannot be turned on unless Q1 is on. The output pulse from the Q2 emitter when Q2 comes on is the timing pulse. When Q1 is turned off Q2 goes off, also.

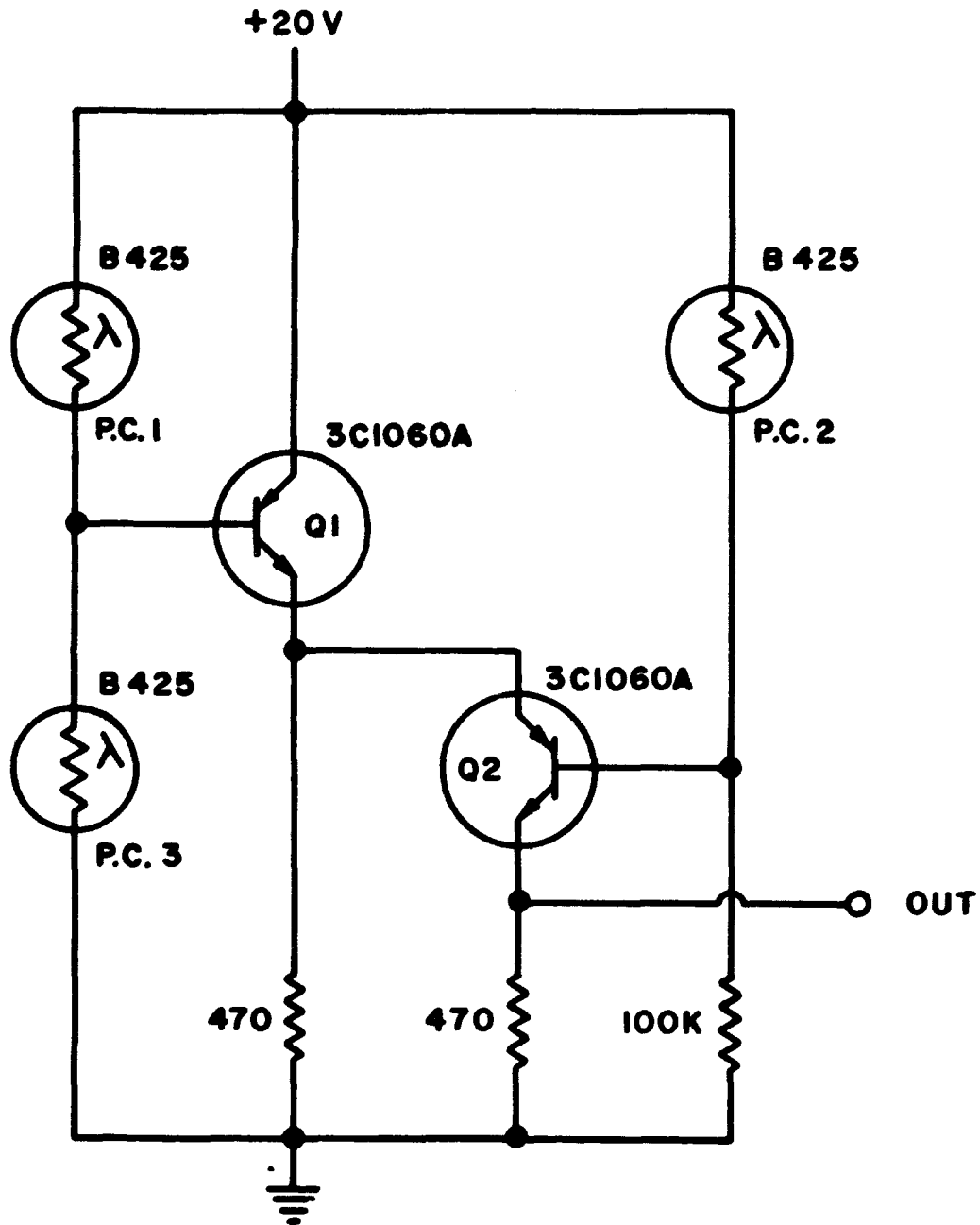

Figure 2. Schematic Diagram of Pulse Recognition Circuit.

Assume Q1 and Q2 are off when the pendulum begins to rotate. If P.C.2 or P.C.3 receives the first pulse, the circuit will not change state because Q1 is already off and P.C.3 can only turn it off. Furthermore, Q2 cannot come on because Q1 must be on first. However, if P.C.1 receives the first pulse, Q1 is turned on. Subsequent pulses from P.C.1 have no effect. Now, either P.C.2 or P.C.3 can have control. However, because of the physical arrangement of P.C.2 and P.C.3, with P.C.2 on the platform, P.C.2 must receive several pulses before P.C.3 receives a pulse. The first pulse on P.C.2 turns on Q2 and subsequent pulses from P.C.2 have no effect. Therefore, a logical, sequential arrangement exists where P.C.1, P.C.2, and P.C.3 control in that order. The timing pulse from Q2 emitter drives a Hewlett Packard Model 5233L Electronic Counter set in the "Period" mode. Thence, the signal is fed into a Hewlett Packard Model 562A Digital Printer, which prints the time period of each cycle of the pendulum.

IV. CONCLUSIONS

When only one period of the pendulum is measured the accuracy of the system described above is no better than that of the system used previously. However, because of the ability of the described system to record every period of the pendulum, and because all the periods are available for an average result, its statistical accuracy is better. Furthermore, all data are automatically recorded, eliminating operator error in reading and recording.

Unclassified
Security Classification

DOCUMENT CONTROL DATA - R&D		
<i>(Security classification of title, body of abstract and indexing annotation must be entered when the overall report is classified)</i>		
1 ORIGINATING ACTIVITY (Corporate author) DEPARTMENT OF THE ARMY Fort Detrick Frederick, Maryland 21701		2a REPORT SECURITY CLASSIFICATION Unclassified
		2b GROUP
3 REPORT TITLE AN AUTOMATED METHOD FOR PERIOD MEASUREMENT OF A TORSIONAL PENDULUM		
4 DESCRIPTIVE NOTES (Type of report and inclusive dates)		
5 AUTHOR(S) (Last name, first name, initial) Stup, Jesse L., Jr.		
6 REPORT DATE September 1966	7a TOTAL NO OF PAGES 10	7b NO OF REFS None
8a CONTRACT OR GRANT NO	8a. ORIGINATOR'S REPORT NUMBER(S)	
8 PROJECT NO 1B522301A080	Technical Manuscript 318	
c	8b OTHER REPORT NO(S) (Any other numbers that may be assigned this report)	
d		
10 AVAILABILITY/LIMITATION NOTICES Qualified requesters may obtain copies of this publication from DDC. Foreign announcement and dissemination of this publication by DDC is not authorized. Release or announcement to the public is not authorized.		
11 SUPPLEMENTARY NOTES	12 SPONSORING MILITARY ACTIVITY DEPARTMENT OF THE ARMY Fort Detrick Frederick, Maryland 21701	
13 ABSTRACT <p>A pulse recognition circuit has been devised that enables it, when used in conjunction with a digital counter and printer, to determine the period of a torsional pendulum even though the amplitude of the pendulum is variable and exceeds 360 degrees. This method is easier to use, saves time, and is more accurate than a mechanical-electro method previously used.</p>		
14. Key Words *Pendulums Mass Optical instruments Count *Torsion Moment Pulsation Sensors Measurement Inertia Light Rotation Period		

DD FORM 1473
1 JAN 64

Unclassified
Security Classification