

UNCLASSIFIED

AD NUMBER

AD803968

LIMITATION CHANGES

TO:

Approved for public release; distribution is unlimited.

FROM:

Distribution authorized to U.S. Gov't. agencies only; Administrative/Operational Use; 31 OCT 1966. Other requests shall be referred to Office of Naval Research, Arlington, VA 22203.

AUTHORITY

ONR ltr 27 Jul 1971

THIS PAGE IS UNCLASSIFIED

803968

EVALUATION OF OXIDE LASER HOSTS

FINAL TECHNICAL SUMMARY REPORT

(For the Period Ending 31 October 1966)

Contract No. Nonr 4660(00)

ARPA Order No. 306-62

Project Code No. 4730

Perkin-Elmer Engineering Report No. 8587

Robert C. Linares
Principal Investigator

The Perkin-Elmer Corporation
Optical Group - Research
Norwalk, Connecticut 06850

EVALUATION OF OXIDE LASER HOSTS

FINAL TECHNICAL SUMMARY REPORT
(For the Period Ending 31 October 1966)

Contract No. Nonr 4660(00)
ARPA Order No. 306-62
Project Code No. 4730

Perkin-Elmer Engineering Report No. 8587

Robert C. Linares
Principal Investigator

Reproduction in whole or in part is permitted for any purpose of the United States Government. This research is part of Project DEFENDER under the joint sponsorship of the Advanced Research Project Agency, the Office of Naval Research and the Department of Defense.

The Perkin-Elmer Corporation
Optical Group - Research
Norwalk, Connecticut 06852

TABLE OF CONTENTS

| <u>Section</u> | <u>Title</u> | <u>Page</u> |
|----------------|---------------------|-------------|
| | ABSTRACT | iv |
| I | INTRODUCTION | 1 |
| II | DIVALENT RARE EARTH | 2 |
| | 2.1 History | 2 |
| | 2.2 Stability | 2 |
| | 2.3 Results | 5 |
| | 2.4 Conclusions | 13 |
| III | TRANSITION METALS | |
| | 3.1 Background | 17 |
| | 3.2 Results | |
| | 3.3 Conclusions | 33 |

LIST OF ILLUSTRATIONS

| <u>Figure</u> | <u>Title</u> | <u>Page</u> |
|---------------|--|-------------|
| 1 | Apparatus for Applying Electric Field During Czochralski Growth | 9 |
| 2 | Transmission of Vacuum Annealed Y_2O_3 | 11 |
| 3 | $Ca_{12}Al_{14}O_{33}:1\%$ Sm Grown in an Electric Field | 12 |
| 4 | Transmission of $CaF_2:Eu^{2+}$ and $Y_2Al_5O_{12}:Eu^{2+}$ | 14 |
| 5 | Transmission of Cobalt in YAG | 19 |
| 6 | Transmission of Manganese in YAG | 23 |
| 7 | Emission of Chromium in $ZnWO_4$ | 24 |
| 8 | Dependence of Intensities of 1.04μ Emission on Concentration and Charge Compensation | 25 |
| 9 | Transmission of Undoped and Chromium-doped $ZnWO_4$ | 27 |
| 10 | Czochralski-Grown $ZnWO_4:Cr, Li .15\%$ | 28 |
| 11 | Emission of Rhodium in Al_2O_3 | 30 |
| 12 | Transmission of Rhodium in Al_2O_3 | 31 |

ABSTRACT

The optical spectra and crystal growth of a wide number of hosts were studied to determine their potential usefulness as laser materials. Two types of ions were studied because of their known broad, efficient, absorption and emission bands: divalent rare earths and transition metals.

The stabilization of divalent rare earths in a large number of oxide crystals was studied with the emphasis on Sm^{2+} . The host crystal cations were selected because of their theoretical stability with divalent rare earths, however, only the combination of Eu^{2+} in $\text{Y}_3\text{Al}_5\text{O}_{12}$ was found to be stable. The transition metals (Sb^{3+} , Bi^{3+} , Co^{2+} , Ni^{2+} , Mn^{2+} , Cr^{3+} and Rh^{3+}), were studied in divalent and trivalent hosts. The emission spectra were measured on all samples at room temperature and at liquid nitrogen temperature, and, in cases where good crystals were available, transmission measurements were made. Fluorescent lifetime and excitation spectra were measured where samples had sufficient intensity. Of the materials measured only $\text{ZnWO}_4:\text{Cr}$ had good spectral properties and could be grown easily. Large crystals of $\text{ZnWO}_4:\text{Cr}$ were grown and fabricated for laser testing.

SECTION I

INTRODUCTION

The purpose of this program is to study potential crystalline laser host-ion combinations for application as efficient, high-energy-storage lasers. In order to achieve high efficiency, broadband absorbers must be used and, to obtain high energy storage, one must have long fluorescent lifetimes and/or broad emission lines. These characteristics might be met in suitable crystals containing divalent rare earths or transition metal ions. Since any eventual device must be capable of mechanical and optical stability, only oxide crystal hosts were studied. Studies included preparation of ceramic and crystal samples, measurement of emission spectra from 0.4 μ to 4.0 μ , absorption spectra, excitation spectra, and fluorescent lifetime.

SECTION II

DIVALENT RARE EARTH

2.1 HISTORY

The divalent rare earths, Sm, Tm, and Dy, incorporated in the alkaline earth fluorides have been successfully used as lasers^{1, 2, 3}. These devices have been exploited primarily for low power and continuous-wave applications because of their narrow linewidth. Specific limitations to the use of these particular materials for high-pulse-power applications are:

1. Narrow linewidth
2. Instability of Re^{2+}
3. Fragility of the host

If successful, the incorporation of divalent rare earths into oxide hosts would be expected to solve the stability and fragility problems.

2.2 STABILITY

Since the trivalent state of the rare earth ion is usually the preferred oxidation state, numerous investigations have searched for a method to prepare and stabilize the rare earths in a divalent state. In the alkaline earth halides divalent rare earths are usually made by conversion of trivalent rare earth in the crystal to divalent by radiation,⁴ high temperature electrolysis,⁵ vapor reduction,⁶ or, in the case of samarium and europium, direct reduction in the crystal growing melt.

In choosing a new host for incorporation of divalent rare earths, it soon becomes evident that ions of the host are largely responsible for the allowed oxidation states of the rare earth ion. If we write the oxidation reduction reaction of a divalent rare earth ion with a typical host cation, it is seen that if the reaction to the left is favored, the divalent rare earth is stable.

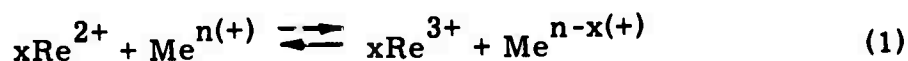

To predict the direction of the reaction, we need only to sum the oxidation potentials, E° , of the two separate reactions (equations 2 and 3).



If $E^\circ_1 - E^\circ_2 < 0$, the divalent rare earth will be stable; if $E^\circ_1 - E^\circ_2 > 0$, the divalent rare earth will not be stable.

This dependence has been shown to be true by Weller⁷ in a study of the divalent rare earths and trivalent uranium in CaF_2 and CdF_2 . Therefore, we have a tool to determine if a divalent rare earth will be stable. Unfortunately, while the oxidation potentials of most of the common elements have been determined, the oxidation potential of only three rare earth elements has been measured. These are the most easily reduced: samarium, europium, and ytterbium. A selected list of oxidation-reduction couples in acid solutions is given in Table I^{8,9}. The rare earths are underlined. We see by inspection of the list that Sm^{2+} , for instance, will not be stable in zirconates, stanates, silicates, germinates, gallates, etc. It also shows that the flux technique cannot be used for these materials since the

TABLE I

OXIDATION REDUCTION COUPLES IN ACID SOLUTION

| <u>COUPLE</u> | <u>E°</u> |
|--|-----------|
| Li = Li ⁺ + e ⁻ | 3.045 |
| K = K ⁺ + e ⁻ | 2.925 |
| Ba = Ba ⁺⁺ + 2e ⁻ | 2.90 |
| Sr = Sr ⁺⁺ + 2e ⁻ | 2.89 |
| Ca = Ca ⁺⁺ + 2e ⁻ | 2.87 |
| Na = Na ⁺ + e ⁻ | 2.714 |
| La = La ⁺⁺⁺ + 3e ⁻ | 2.52 |
| Nd = Nd ⁺⁺⁺ + 3e ⁻ | 2.44 |
| Gd = Gd ⁺⁺⁺ + 3e ⁻ | 2.40 |
| Mg = Mg ⁺⁺ + 2e ⁻ | 2.37 |
| Y = Y ⁺⁺⁺ + 3e ⁻ | 2.37 |
| H(g) = H ⁺ + e ⁻ | 2.10 |
| Th = Th ⁺⁴ + 4e ⁻ | 1.90 |
| Be = Be ⁺⁺ + 2e ⁻ | 1.85 |
| Hf = Hf ⁺⁴ + 4e ⁻ | 1.70 |
| Al = Al ⁺⁺⁺ + 3e ⁻ | 1.66 |
| <u>Sm²⁺ → Sm³⁺ + e⁻</u> | 1.55 |
| Zr = Zr ⁺⁴ + 4e ⁻ | 1.53 |
| <u>Yb²⁺ → Yb³⁺ + e⁻</u> | 1.15 |
| B + 3H ₂ O = H ₃ BO ₃ + 3H ⁺ + 3e ⁻ | 0.8 |
| Ga = Ga ⁺⁺⁺ + 3e ⁻ | 0.53 |
| <u>Eu⁺⁺ = Eu⁺⁺⁺ + e⁻</u> | 0.43 |
| Pb = Pb ⁺⁺ + 2e ⁻ | 0.126 |

common fluxes contain Pb^{2+} , Bi^{3+} , Mo^{6+} , etc. From this chart, we can bracket the oxidation potential of some of the other divalent rare earths with the aid of recent results on divalent rare earth systems. The following is known about dysprosium, thulium and holmium:

1. Dy^{2+} is stable in CaF_2 but not in LaF_3 .
2. Tm^{2+} is stable in LaF_3 but is not formed with H_2 .
3. Ho^{2+} is slowly formed by the action of H_2 on Ho^{3+} .

From this information and that given in Table I, we show in Table II the hosts cations that are potentially most suitable for the various ions. While no reports have been made of fluorescence of divalent rare earths in oxides, we know divalent rare earths are stable in oxides by the formation of compounds such as EuO , SmO , Eu_2SiO_4 , EuGd_2O_4 and $x\text{EuO} \cdot y\text{Al}_2\text{O}_3 \cdot z\text{SiO}_2$ glasses.

2.3 RESULTS

2.3.1 Ceramics

For the initial work, hosts which would be representative of the entire range above Sm^{2+} were studied using Sm^{2+} since it was considered the most easily stabilized ion of useful spectral properties. As it was desirable to introduce the Re^{2+} without charge compensation, alkaline earth ions were considered, as well as trivalent cations. A number of known compounds, solid solutions, and potential new compounds were prepared by vacuum sintering at 1400-1900°C depending on the material. These were doped with 1 atom percent samarium. The materials were tested for atmospheric stability and studied for Sm^{2+} emission at room temperature and at liquid nitrogen temperature. The result of this study is given in Table III, which lists the compound, the stability in air, the formation of compounds, color (all of these materials are white when prepared in air), and valence as determined from emission spectra. It was evident from this work that few

TABLE II

HOST CATIONS SUITABLE FOR VARIOUS DIVALENT RARE EARTHS*

| | | |
|--------------------|---|---|
| | Li^{1+} K^{1+} Ba^{2+} Sr^{2+} Ca^{2+} | |
| Dy^{2+} | Na^{1+} | |
| | | La^{3+} Nd^{3+} Gd^{3+} Mg^{2+} Y^{3+} |
| Tm^{2+} | | |
| | | H(g) Sc^{3+} |
| † Ho^{2+} | | |
| | | Th^{4+} Be^{2+} Hf^{4+} Al^{3+} |
| Sm^{2+} | | |

* Host Cations Above Line are Suitable for Divalent Rare Earth on Line

† Recent work indicates Ho^{2+} should be above Dy^{2+} in this series.

J. Corbett, D. Pollard, and J. Mee, Inorganic Chemistry, 5, 761 (May 1966)

TABLE III

PROSPECTIVE OXIDE HOSTS FIRED IN VACUUM

| <u>MATERIAL</u> | <u>STABILITY IN AIR</u> | <u>COMPOUND FORMATION</u> | <u>COLOR</u> | <u>Smⁿ⁺</u> |
|---|-----------------------------|-------------------------------|--------------|------------------------|
| Y ₂ O ₃ | S | N | Blue | 3+ |
| CaY ₂ O ₄ | S | Cp | White | 3+ |
| SrY ₂ O ₄ | S | Cp | White | 3+ |
| BaY ₂ O ₄ | S | Cp | White | 3+ |
| CaLa ₂ O ₄ | U | ? | White | 3+ |
| SrLa ₂ O ₄ | U | ? | White | 3+ |
| BaLa ₂ O ₄ | U | ? | White | 3+ |
| CaMgO ₂ | U | SS | White | 3+ |
| SrMgO ₂ | U | SS | White | 3+ |
| BaMgO ₂ | U | SS | White | 3+ |
| BaThO ₃ | S | C | White | 3+ |
| Y ₃ Al ₅ O ₁₂ | S | C | Blue | 3+ |
| Ca ₁₂ Al ₁₄ O ₃₃ | S | C | Blue | 3+ |

S = Stable
 N = No Compound
 Cp = Compound

U = Unstable
 SS = Solid Solution

compounds with the desired cations would be useful from a stability point of view, and that vacuum annealing alone did not produce detectable amounts of divalent rare earth, even though the samples were discolored as though reduced. Accordingly, experiments were conducted to study samarium in single crystals, notably Y_2O_3 , $Ca_{12}Al_{14}O_{33}$, and CaY_2O_4 .

2.3.2 Single Crystals

2.3.2.1 Preparation

Single crystals for this study were prepared only by melt methods in order to avoid the inclusion of foreign ions into the host crystal. The flame fusion and Czochralski techniques were used. An argon atmosphere was used in the Czochralski growth chambers in an attempt to prevent oxidation of the divalent rare earth.

Several experiments were made in which electrolytic reduction of the rare earth was attempted during crystal growth. In these experiments platinum or iridium electrodes were immersed in the melt and a current was passed over the face of the crystal as it grew (Figure 1). The current was varied from 1 to 150 milliamperes during growth.

2.3.2.2 Yttrium Oxide (Y_2O_3)

Crystals of Y_2O_3 were prepared by the flame fusion technique using power prepared by calcining five 9's pure yttrium oxalate. Three types of samples were prepared:

1. Y_2O_3
2. Y_2O_3 : 1% Sm
3. Y_2O_3 : 1% Sm + 1% Th^{4+}

These crystals ranged from colorless to light straw yellow and gave strong fluorescence characteristic of Sm^{3+} . Exposure to 40KeV X-rays for eight

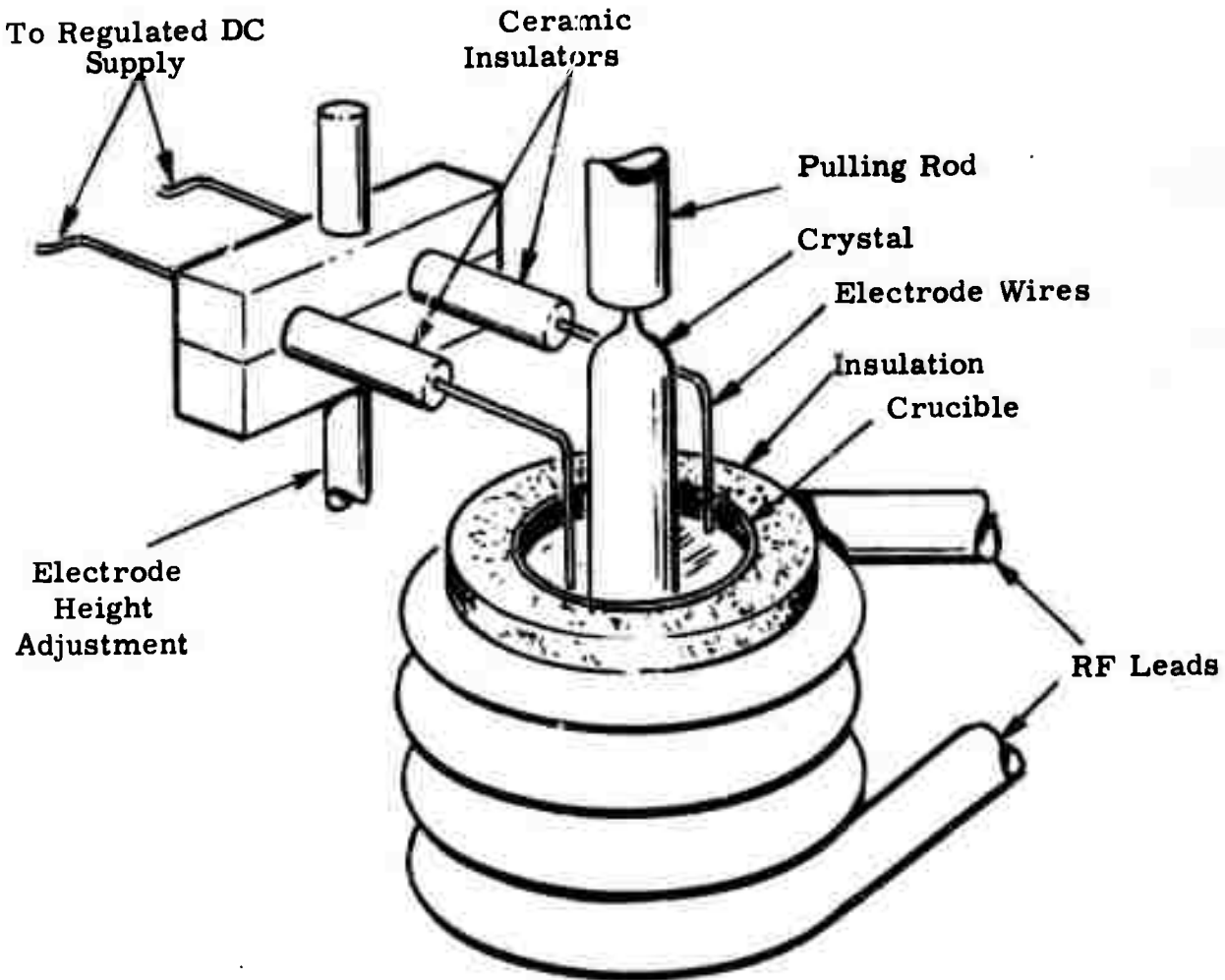
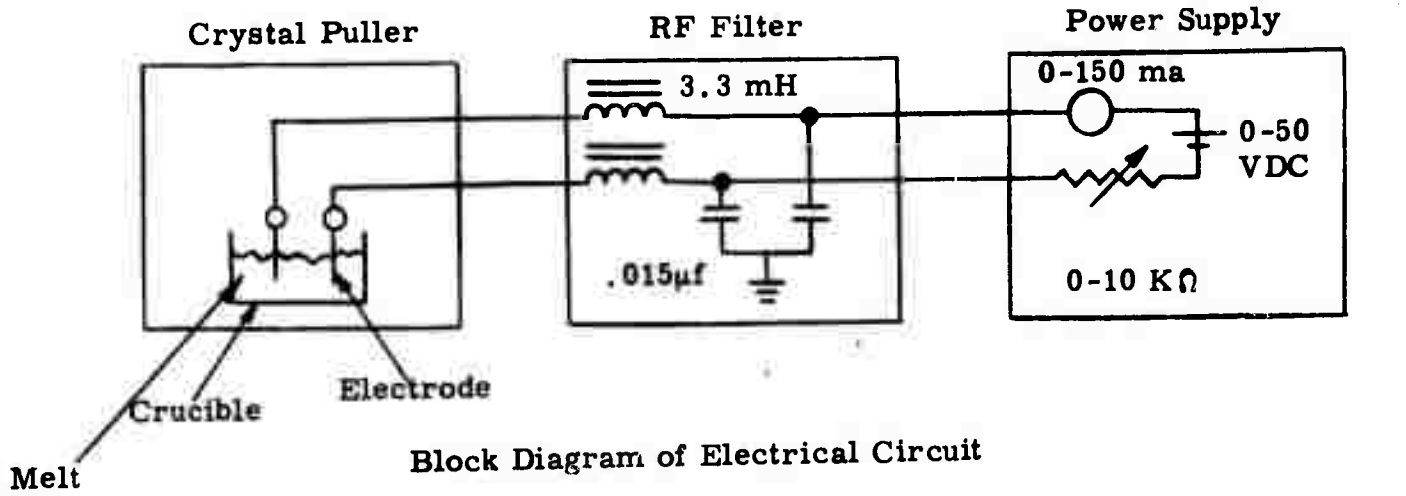

Figure 1. Apparatus for Applying Electric Field During Czochralski Growth.

hours did not produce discoloration or a change in spectra. Annealing at 1900°C for four hours at 10^{-5} torr, caused the crystals to turn anywhere from dark blue to black (including the undoped one). However, only fluorescence attributable to trivalent samarium was observed. Study of the transmission spectra showed an absorption in the visible (Figure 2), which was identical for the doped and undoped crystals. This coloration, therefore, appears to be a color center associated with the Y_2O_3 host rather than the Sm. A difference was seen in the infrared transmission of the sample containing samarium and thorium. New lines appear in this sample at 2.22μ and 2.45μ which are not present when the sample is oxidized and which are not attributable to Sm^{3+} . However, no emission was found at any wavelength which was attributable to Sm^{3+} .

2.3.2.3 Calcium Aluminate ($Ca_{12}Al_{14}O_{33}$)

Crystals of this compound have been grown by the Czochralski technique. It is a particularly attractive host since it is cubic and melts at only 1450°C¹⁰. Crystals grown in an oxidizing atmosphere range from colorless to yellow and give a typical Sm^{3+} emission. Crystals grown in a neutral atmosphere are pale blue, but give no emission other than that attributed to Sm^{3+} . Discoloration occurred with X-radiation but no change in emission was seen. Transmission spectra on these crystals showed no change which might suggest the presence of Sm^{2+} . Attempts were made to stabilize Sm^{2+} by annealing the crystals at 1350°C at 10^{-5} torr for 24 hours. No Sm^{2+} was formed.

Electrolysis during growth produced distinct color changes in the crystal with currents as low as 10 milliamperes. Currents in excess of 50 milliamperes resulted in bubbling and gradual erosion of one electrode and plating on the other. The crystal obtained when various currents are passed through the melt is green as Sm^{2+} should be (Figure 3). However, no emission attributable to Sm^{2+} was seen, and the crystal did not become colorless when annealed in oxygen. The green color is believed to be due to platinum which was incorporated as a result of the electrolysis.

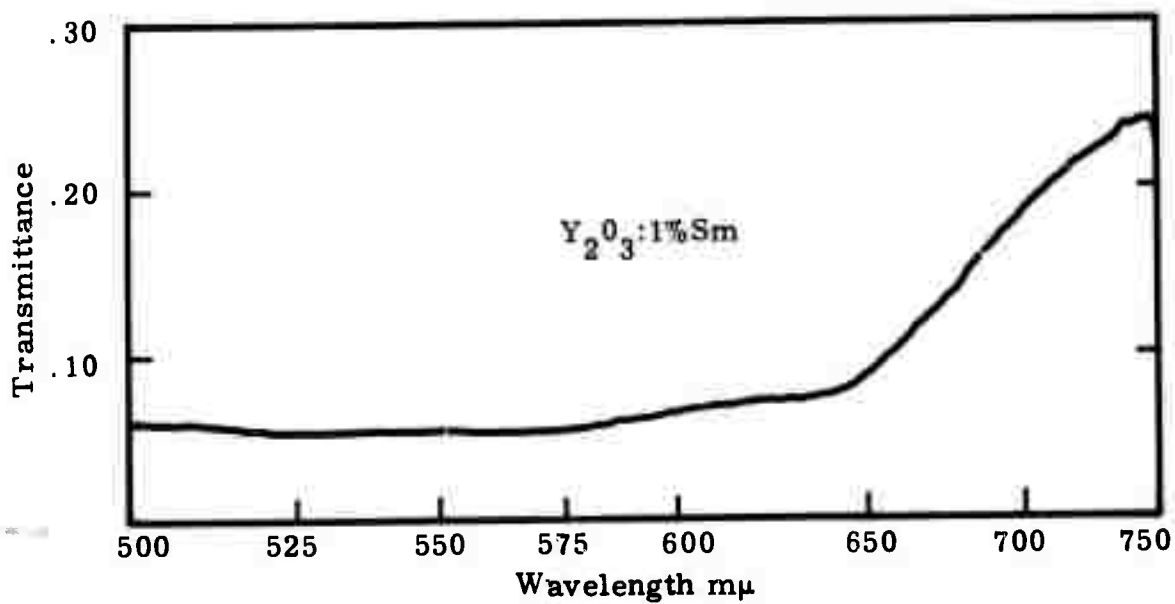
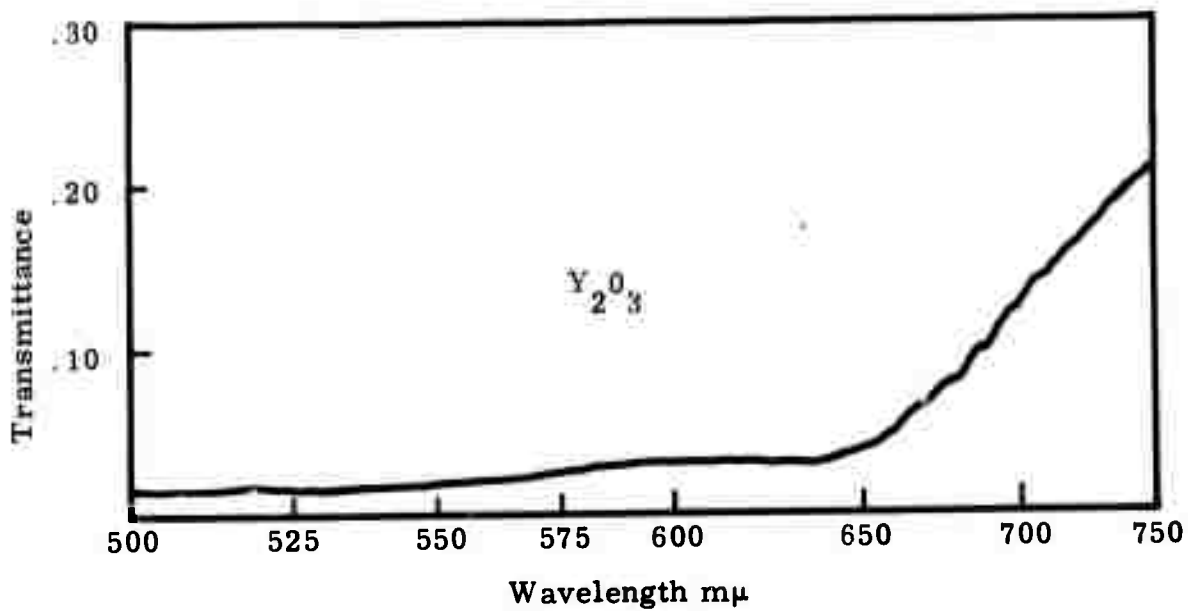

Figure 2. Transmission of Vacuum Annealed Y₂O₃



Figure 3. $\text{Ca}_{12}\text{Al}_{14}\text{O}_{33}:1\% \text{Sm}$ Grown in an Electric Field

2.3.2.4 Calcium Yttrium Oxide (CaY_2O_4)

Apparently, CaY_2O_4 is a new compound. The structural details, melting point, and physical properties are not known, however, it is probably similar to CaGd_2O_4 which is orthorhombic.¹¹ Preliminary X-ray data on CaY_2O_4 are given in Table IV. We grew small crystals by the flame fusion method, and tried to grow it by the Czochralski technique, however, the compound appeared to be incongruently melting.

Flame fusion crystals doped with 1% samarium showed only Sm^{3+} fluorescence even after vacuum annealing and X-ray exposure. X-ray damage produced considerable coloration but no change in fluorescence.

2.3.2.5 $\text{Y}_3\text{Al}_5\text{O}_{12}$

Single crystals of $\text{Y}_3\text{Al}_5\text{O}_{12}$ were grown from the melt with samarium or europium dopings. No evidence of divalent samarium was seen in crystals which were as grown, vacuum annealed with electrolysis, or X-ray damaged. No change was observed in YAG:Sm when currents up to 150 milliamperes were passed through the melt during growth.

Melt-grown $\text{Y}_3\text{Al}_5\text{O}_{12}$ doped with europium was purple as one might expect from Eu^{2+} . The absorption spectra of YAG:Eu and that of $\text{CaF}_2:\text{Eu}^{2+}$ are similar except for the relative intensity of the bands (Figure 4). A search for emission from europium in $\text{Y}_3\text{Al}_5\text{O}_{12}$ showed no emission other than weak lines of Eu^{3+} . Both X-ray and mercury emission were employed for excitation at room and liquid nitrogen temperatures.

2.4 CONCLUSIONS

Attempts to stabilize Sm^{2+} in a number of oxide hosts were all unsuccessful. Divalent europium appeared to be stabilized in $\text{Y}_3\text{Al}_5\text{O}_{12}$,

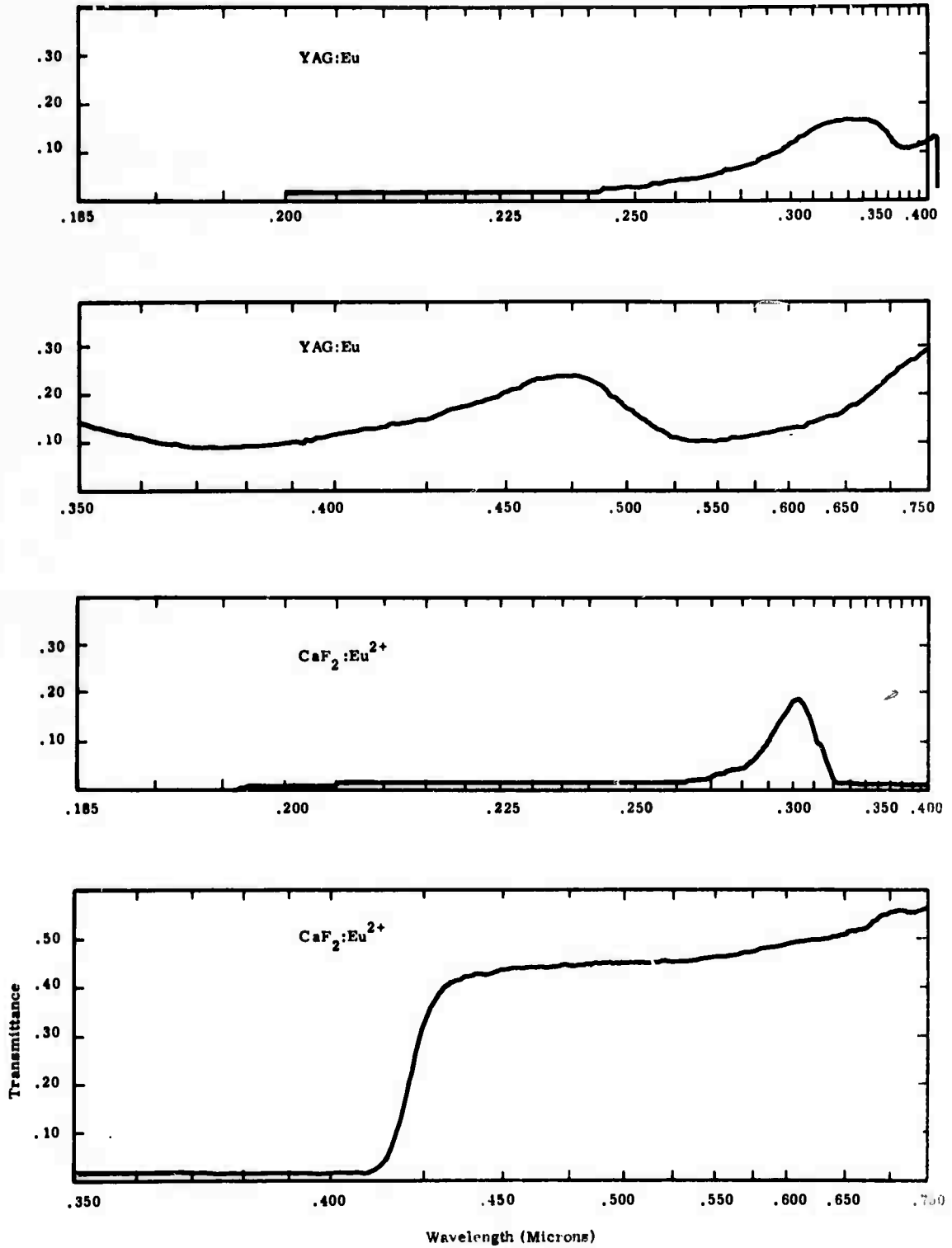

Figure 4. Transmission of CaF₂:Eu²⁺ and Y₂A1₅O₁₂:Eu²⁺

TABLE IV

POWER X-RAY DIFFRACTION DATA ON CaY_2O_4

$(\lambda = 1.54\text{\AA})$

| <u>d</u> | <u>I/I₀</u> |
|----------|------------------------|
| 4.36 | 7 |
| 3.13 | 10 |
| 3.07 | 100 |
| 2.92 | 4 |
| 2.73 | 3 |
| 2.65 | 19 |
| 2.50 | 4 |
| 2.34 | 5 |
| 2.26 | 8 |
| 2.13 | 4 |
| 2.07 | 5 |
| 2.03 | 15 |
| 1.87 | 34 |
| 1.72 | 3 |
| 1.68 | 3 |
| 1.60 | 16 |
| 1.57 | 3 |
| 1.53 | 3 |

however, no emission was seen from the ion. It does not appear from this study that oxides are suitable hosts for any divalent rare earths because the two easily stabilized ions (Sm^{2+} and Eu^{2+}) either do not reduce readily or do not have desirable spectral properties.

SECTION III

TRANSITION METALS

3.1 BACKGROUND

The transition metal ions (Cr^{3+} , Ni^{2+} , Co^{2+} , and V^{2+}) have been successfully used in lasers¹²⁻¹⁵. These ions have very broad absorption bands enabling them to efficiently absorb pump light. While Cr^{3+} is operated in an oxide host, the other transition metals operate in a fluoride host which is subject to the fragility mentioned previously. These ions have reasonably narrow electronic emission transitions in many hosts. The goal of this study was to find relatively broad emissions which could store large amounts of energy. The ions studied initially were Mn^{2+} , Co^{2+} , Ni^{2+} , Co^{3+} , Rh^{3+} , Bi^{3+} , and Sb^{3+} . The hosts studied were prepared as single crystals, fusions, or ceramics depending on the material.

3.2 RESULTS

3.2.1 Trivalent Bismuth and Antimony (Bi^{3+} and Sb^{3+})

Bismuth and antimony were incorporated at 0.1% level into Y_2O_3 , In_2O_3 , and Gd_2O_3 . Of these, only the Y_2O_3 : Bi was found to exhibit detectable fluorescence. This was a weak emission centered at 4000Å.

3.2.2 Divalent Nickel and Cobalt (Ni^{2+} and Co^{2+})

Nickel and cobalt were incorporated into YAG ($\text{Y}_3\text{Al}_5\text{O}_{12}$) at 1.0%, 0.1%, and 0.01% levels. No emission was seen from these from 1.0μ to 4.0μ at room or liquid nitrogen temperature.

Transmission studies were made of uncompensated and zirconium-compensated Co^{2+} in YAG. Figure 5 shows two spectra observed in the different samples. Shifts have also been observed in cobalt-doped yttrium gallium garnet by Pappalardo.¹⁶ This band contains the level from which fluorescence (and laser action) originates in the fluoride.¹⁴ Therefore, the 500\AA shift seen in the peak might be expected to cause a similar shift in the emission peak.

Other hosts to be studied should not have had multiple sites for Co^{2+} or Ni^{2+} . These were MgO , ZnO , and ZnAl_2O_4 , and other garnets including materials synthesized under this contract, such as $\text{Ca}_3\text{Al}_{3.5}\text{Nb}_{1.5}\text{O}_{12}$. However, due to late delivery of an InAs detector, time did not permit a full study of these materials.

3.2.3 Divalent Manganese (Mn^{2+})

Divalent manganese was studied in $\text{Y}_3\text{Al}_5\text{O}_{12}$, $\text{Ca}_{12}\text{Al}_{14}\text{O}_{33}$, CaGa_2O_4 , and CaGa_4O_7 . Emission was seen in all of these. Some properties of these materials are given in Table V.^{10, 17} From the melting points we can see that all of these materials can be grown by the Czochralski technique.

Table VI shows the position, width, and relative intensity of these emission lines. Note that the $\text{Y}_3\text{Al}_5\text{O}_{12}:\text{Mn}^{2+}$ with zirconium compensation is much brighter than the uncompensated or fluorine-compensated manganese. Also, the $\text{Ca}_{12}\text{Al}_{14}\text{O}_{33}$ grown in H_2 is brighter than that grown in argon or air. The compound grown in H_2 is pink and the air grown compound is muddy orange. The difference is attributed to mixed valence states in the air grown samples. The argon grown sample is also pink but possibly mixed valence because of its low fluorescence. The CaGa_2O_4 and CaGa_4O_7 are very bright compared to the others yet do not have the broadest linewidths. No fluorescent lifetime data were obtained as most samples did not have sufficient fluorescence intensity.

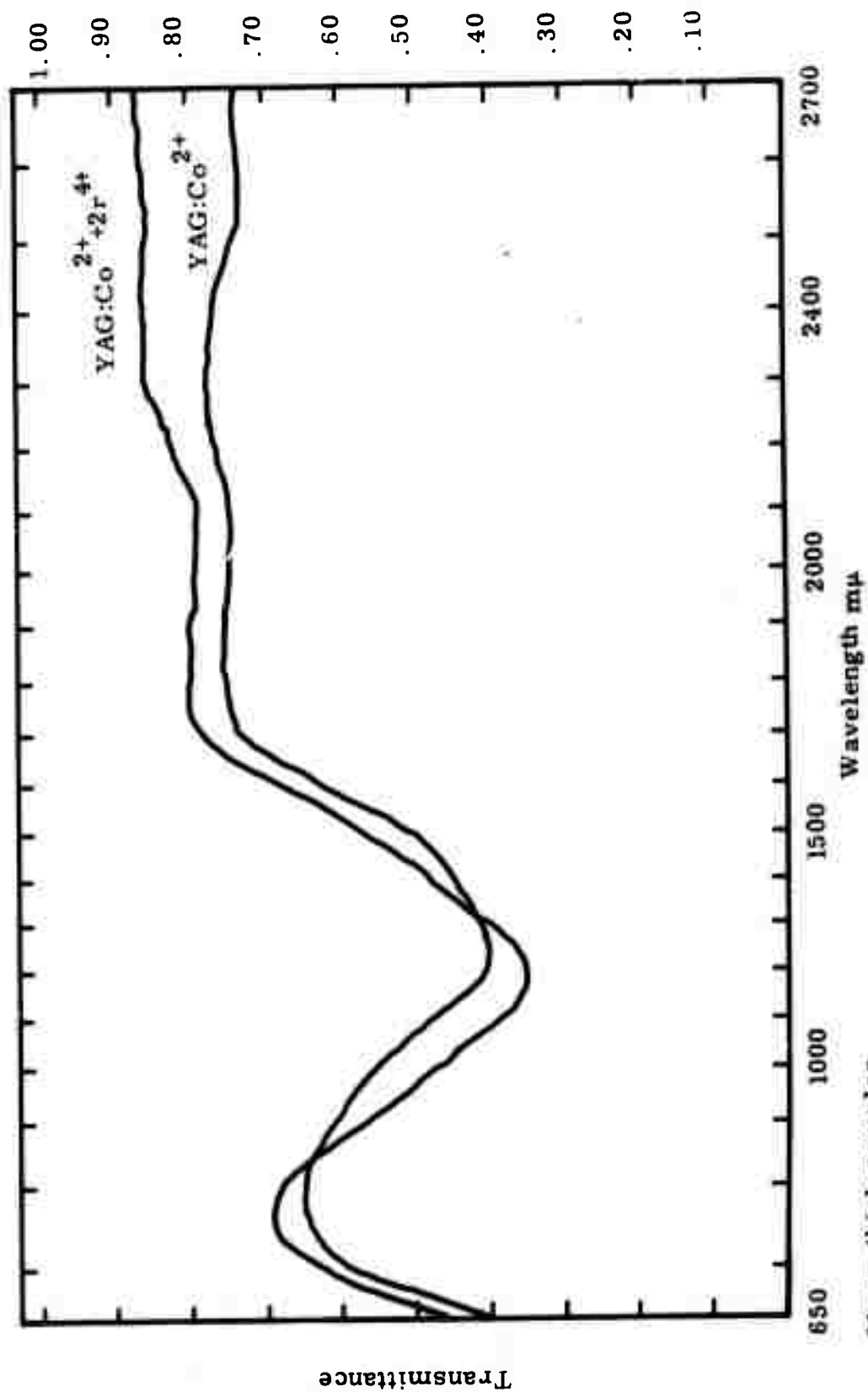

*1mm thick samples

Figure 5. Transmission of Cobalt in YAG

TABLE V

PROPERTIES OF SOME HOSTS FOR Mn²⁺

| <u>HOST</u> | <u>STRUCTURE</u> | <u>INDEX OF REFRACTION</u> | <u>MELTING POINT (°C)</u> |
|---|------------------|------------------------------------|-------------------------------|
| $\text{Y}_3\text{Al}_5\text{O}_{12}$ | Cubic | 1.83 | 1950 |
| $\text{Ca}_{12}\text{Al}_{14}\text{O}_{12}$ | Cubic | | 1450 |
| CaGa_2O_4 | Orthorhombic | > 1.77 | 1369 |
| CaGa_4O_7 | Orthorhombic | 1.74 | 1504 |

TABLE VI

EMISSION OF Mn²⁺ IN VARIOUS HOSTS

| <u>COMPOUND</u> | <u>λ (Å)</u> | <u>Δλ (Å)</u> | <u>RELATIVE INTENSITY</u> |
|---|--------------|---------------|---------------------------|
| Y ₃ Al ₅ O ₁₂ : 1% Mn | 5900 | 490 | 150 |
| Y ₃ Al ₅ O ₁₂ : 1% Mn + F | 5900 | 490 | 450 |
| Y ₃ Al ₅ O ₁₂ : 1% Mn + Zr | 5900 | 490 | 520 |
| Ca ₁₂ Al ₁₄ O ₃₃ : 0.1% Mn (Air) | 6050 | 610 | 200 |
| Ca ₁₂ Al ₁₄ O ₃₃ : 0.1% Mn (Argon) | 6050 | 610 | 200 |
| Ca ₁₂ Al ₁₂ O ₃₃ : 0.1% Mn (H ₂) | 6050 | 610 | 740 |
| CaGa ₂ O ₄ : 1% Mn | 5715 | 570 | 1600 |
| CaGa ₄ O ₇ : 1% Mn | 5785 | 500 | 1000 |

The transmission spectra of $Y_3Al_5O_{12}:1\% Mn^{2+} + F^{1-}$, grown from a flux, are shown in Figure 6. These spectra are less complex than the uncompensated Mn^{2+} spectra reported by Olhmann¹⁸ probably because only one manganese valence is present.

3.2.4 Trivalent Chromium (Cr^{3+})

Trivalent chromium was incorporated into Y_2O_3 , Gd_2O_3 , and $ZnWO_4$; only $ZnWO_4$ exhibited emission. The emission spectra of 0.13% Cr^{3+} in $ZnWO_4$ are shown in Figure 7. The emission is at 1.04μ and the line is 1240\AA wide. This band has also been observed by Johnson,¹⁹ and is attributed to emission from the chromium 4T_2 level to the vibrational band. The large shift in wavelength occurs because the energy of the 4T_2 level is very sensitive to changes in the crystal field of its host. The electronic transitions are apparently buried in this band, and have not been observed by Johnson or in this work at temperatures down to $77^\circ K$.

The linewidth and brightness were studied as a function of concentration, charge compensation, and temperature. These three variables were found to have no effect on linewidth. This is not surprising at our temperatures of measurement ($77^\circ K$ and $300^\circ K$) since this is a vibrational band. Brightness was strongly dependent on these variables. Figure 8 shows the dependence of brightness on concentration and charge compensation. The brightest composition is obtained when 0.13 At% Cr^{3+} replaces Zn^{2+} and 0.13 At% Nb^{5+} replaces W^{6+} . As in the case of Nd^{3+} in $CaMoO_3$, the Nb^{5+} compensation is superior to no compensation or monovalent compensation.²⁰ Brightness is found to increase by a factor of 2.5 upon cooling to liquid nitrogen.

The fluorescence lifetime is found to be $20\ \mu\text{sec}$ at room temperature and $80\ \mu\text{sec}$ at liquid nitrogen temperature. Within the precision of the experiment, no dependence of lifetime on concentration or charge compensation was observed.

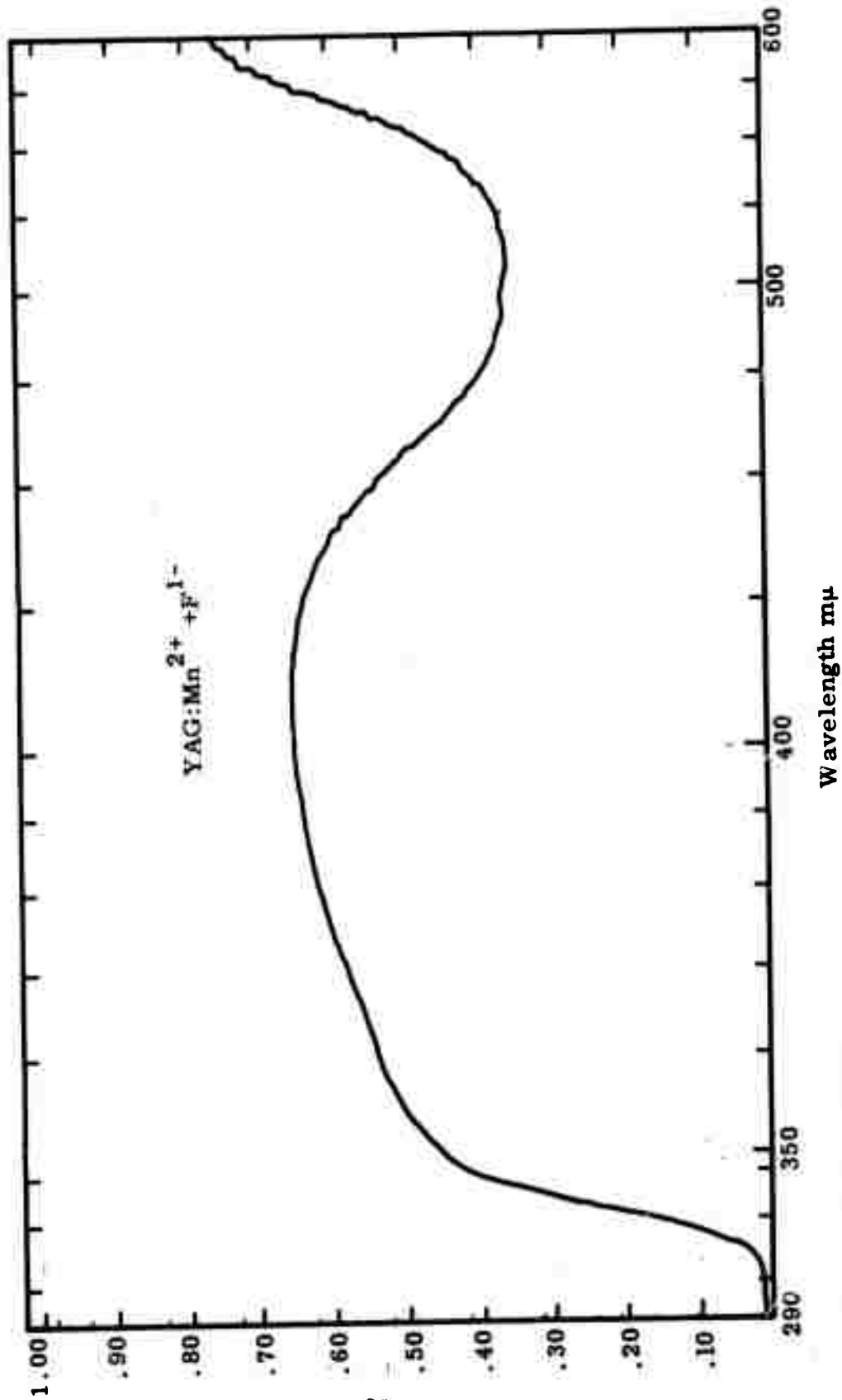

* 1mm thick sample

Figure 6. Transmission of Manganese in YAG

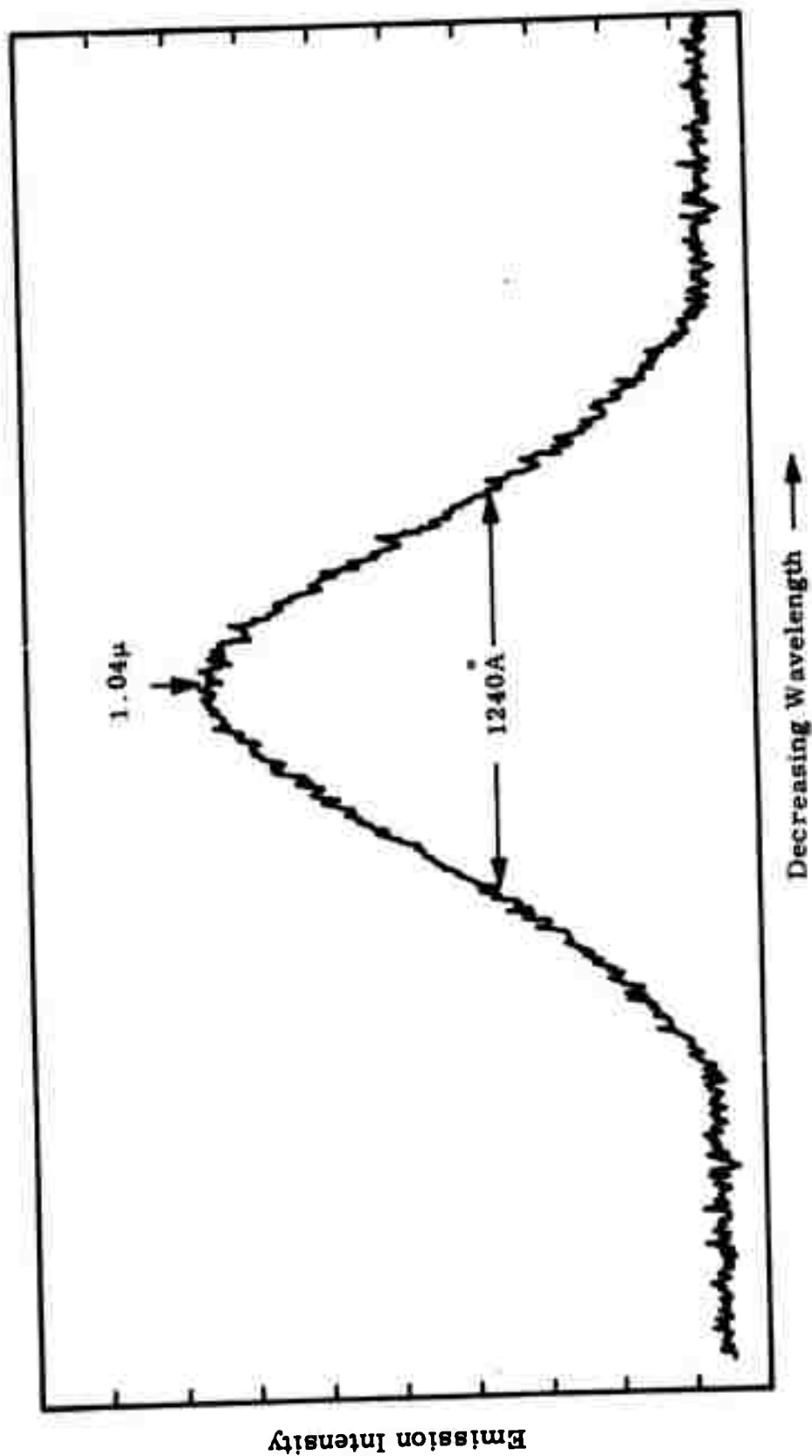

Figure 7. Emission of Chromium in ZnWO₄

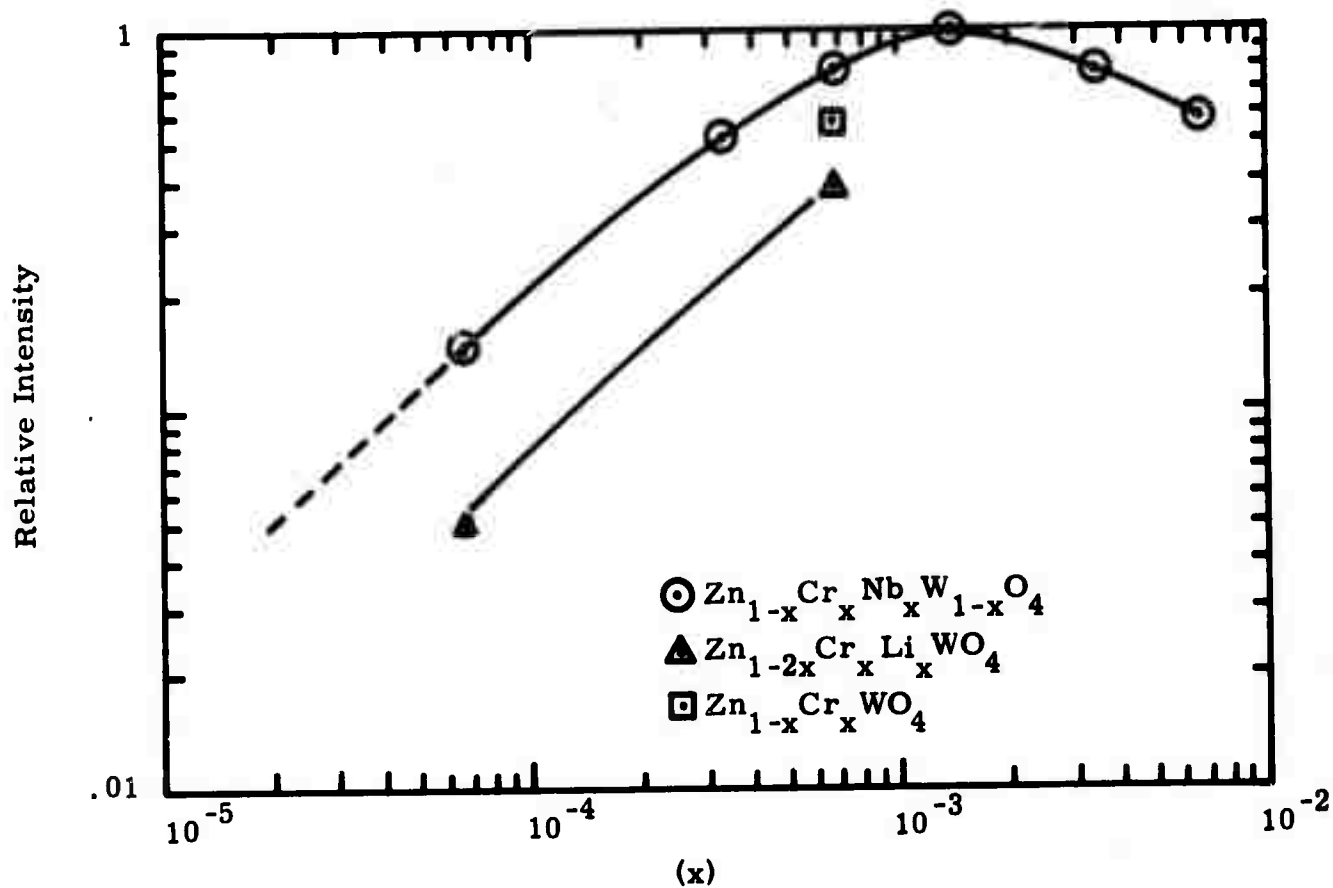

Figure 8. Dependence of Intensities of 1.04μ Emission on Concentration and Charge Compensation

The overall brightness of the optimum sample was compared with that of neodymium glass (type Corning 0580). Using a tungsten lamp for illumination, the brightness of $\text{ZnWO}_4:0.13\% \text{ Cr}$ fluorescence was found to be 21% of the glass. It was observed that $\sim 1/6$ of the fluorescence intensity could be attributed to pumping the green Cr^{3+} bands where the tungsten lamp had little output. Therefore, it appears that when pumping with a xenon flash lamp, the fluorescence intensity may be equal to neodymium glass.

The absorption spectra of pure and chromium-doped ZnWO_4 is shown in Figure 9. The absorption edge was found to vary greatly with different sources of raw materials. Colorless undoped crystals could only be grown from ZnO and WO_3 from City Chemical Co., New York, New York. An excitation spectra showed that the absorptions at 5250\AA and 7300\AA contribute to fluorescence at 1.04μ .

The crystal structure of ZnWO_4 is monoclinic,²¹ and has a melting point of 1206°C . It can be readily prepared as quite large crystals by the Czochralski technique.²² Large crystals of $\text{ZnWO}_4:\text{Cr}$ were grown with Li^{1+} , Nb^{5+} , or Ta^{5+} as charge compensation for Cr^{3+} . Crystals containing Nb^{5+} or Ta^{5+} could never be grown free of gross twinning and cracking while twin-free crystals of $\text{ZnWO}_4:\text{Cr}^{3+} + \text{Li}^{1+}$ could be grown 5 inches long by $1/2$ inch diameter. Figure 10 shows a typical crystal grown at $1/4$ inch per hour. From this crystal a rod for laser testing was fabricated which was $1/4$ inch diameter by $3-3/4$ inches long. This rod was sent to V.O. Nicolai at O.N.R.

Work was continued on chromium fluorescence in materials of the ZnWO_4 structure. Emission at 1μ was detected in MgWO_4 and AlNbO_4 host, but not in ZnMoO_4 or MgMoO_4 . MgWO_4 appears to have a destructive phase change just below its melting point and AlNbO_4 is incongruently melting which makes conventional melt growth of these materials impossible.

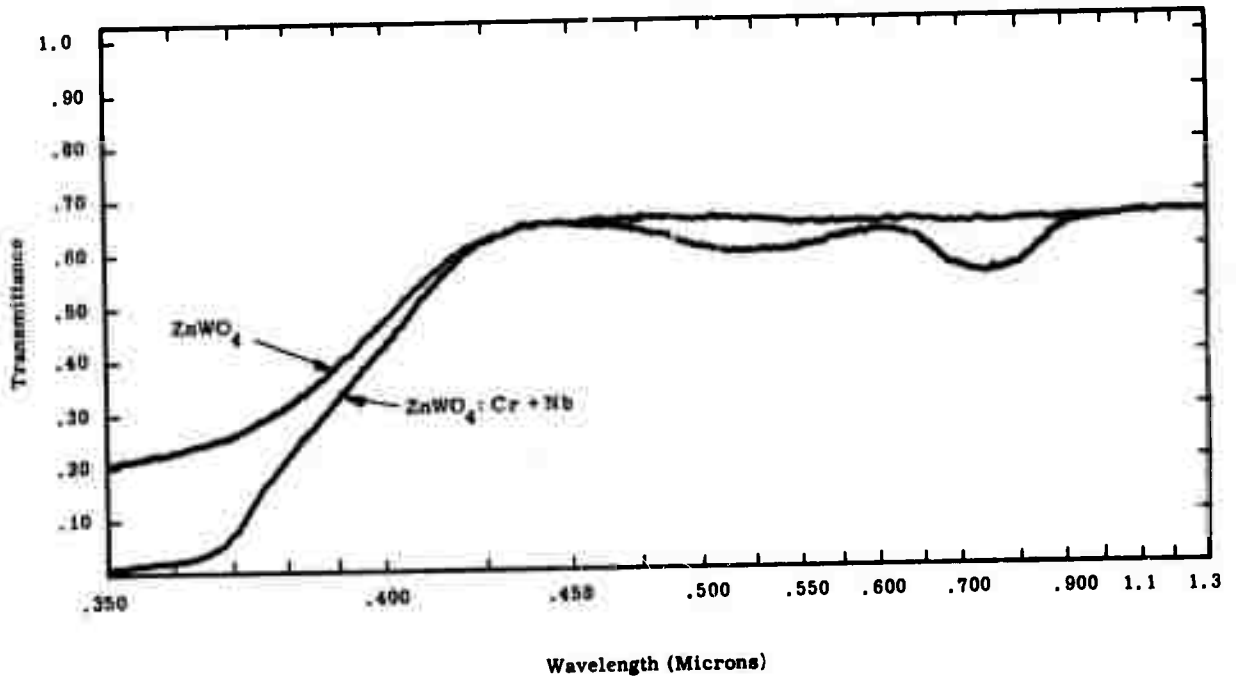

Figure 9. Transmission of Undoped and Chromium-doped ZnWO₄

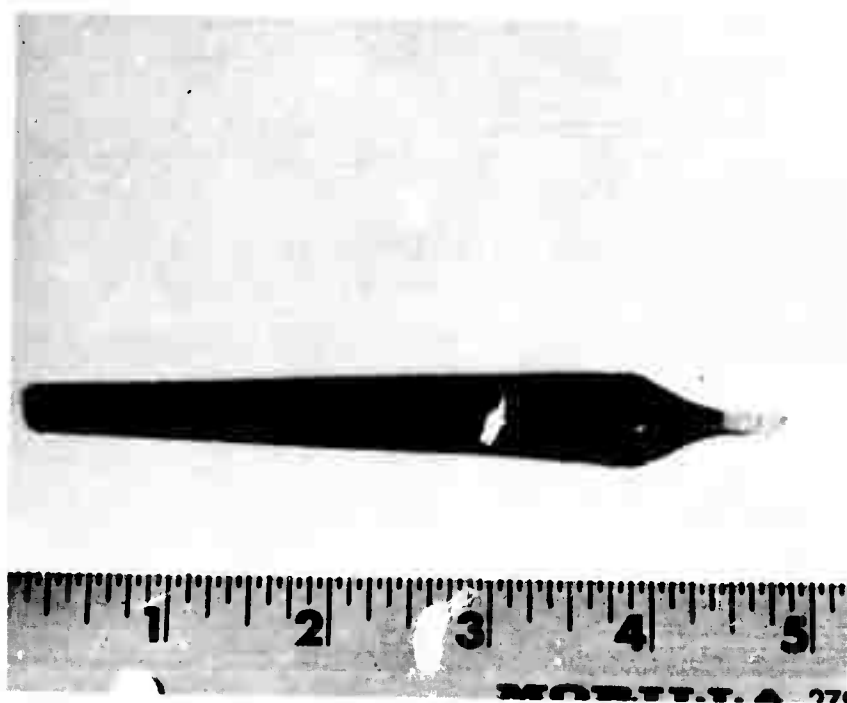

Figure 10. Czochralski-Grown ZnWO₄: Cr, Li .15%

3.2.5 Trivalent Rhodium (Rh³⁺)

Trivalent rhodium was incorporated into Al_2O_3 by growing sapphire from PbO-PbF_2 flux²³ in Pt 13% Rh crucibles. Using this technique at temperatures of 1000-1250°C, dopings of 0.25 At% Rh³⁺ were obtained. The fluorescence spectra of Rh³⁺ in sapphire at room temperature are shown in Figure 11. The line is at 6290Å at room temperature and 770Å wide. At liquid nitrogen temperature the peak shifts to 6320Å, remains 770Å wide, but is a factor of 2.5 brighter. The room temperature brightness is equal to that of ruby under similar pumping. The fluorescent lifetime is 0.24 msec at room temperature, and 0.58 msec at liquid nitrogen temperature.

The visible/ultraviolet transmission spectra of $\text{Al}_2\text{O}_3:0.25\% \text{Rh}^{3+}$ are shown in Figure 12. This shows three wide bands at 3150Å, 3920Å, and ~4850Å. All of these bands have been found to excite fluorescence at the 6290Å band. Weak absorptions were found at 3.2μ and 3.5μ; neither is a good match as a terminal level even considering the uncertainty in position of the 4850Å band. Because of these uncertainties, a tentative energy level diagram cannot be drawn at this time. However, it appears that the 6290Å fluorescence is a four level system and terminates at least 3000 cm⁻¹ above the ground state.

Because of these interesting results, other methods of incorporating Rh³⁺ into sapphire were considered so that larger samples could be studied. These included melt, vapor and diffusion techniques.

In the flame fusion experiments, boule powder was prepared by firing a mixture of alum and RhCl_3 powder. Boules grown from this powder were perfectly colorless and did not fluoresce. It was found that heating a rhodium-doped flux-grown crystal to 1950°C resulted in the precipitation of the metal in the crystal. It is known that Rh_2O_3 disassociates to rhodium metal at elevated temperatures. Presumably in the flame fusion torch, the rhodium oxide disassociates to metal and either does not enter the crystal or enters the crystal as metal.

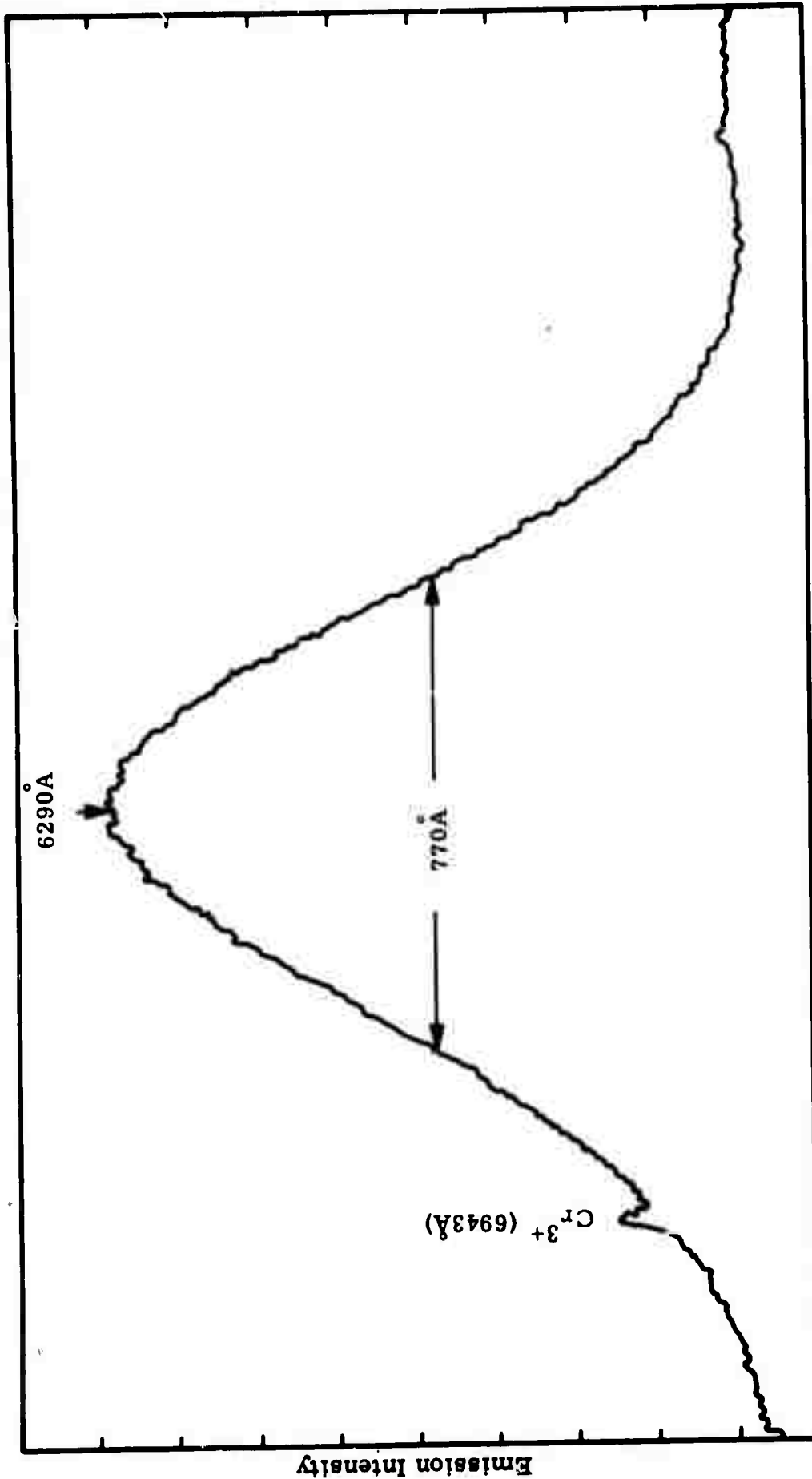

Figure 11. Emission of Rhodium in Al_2O_3

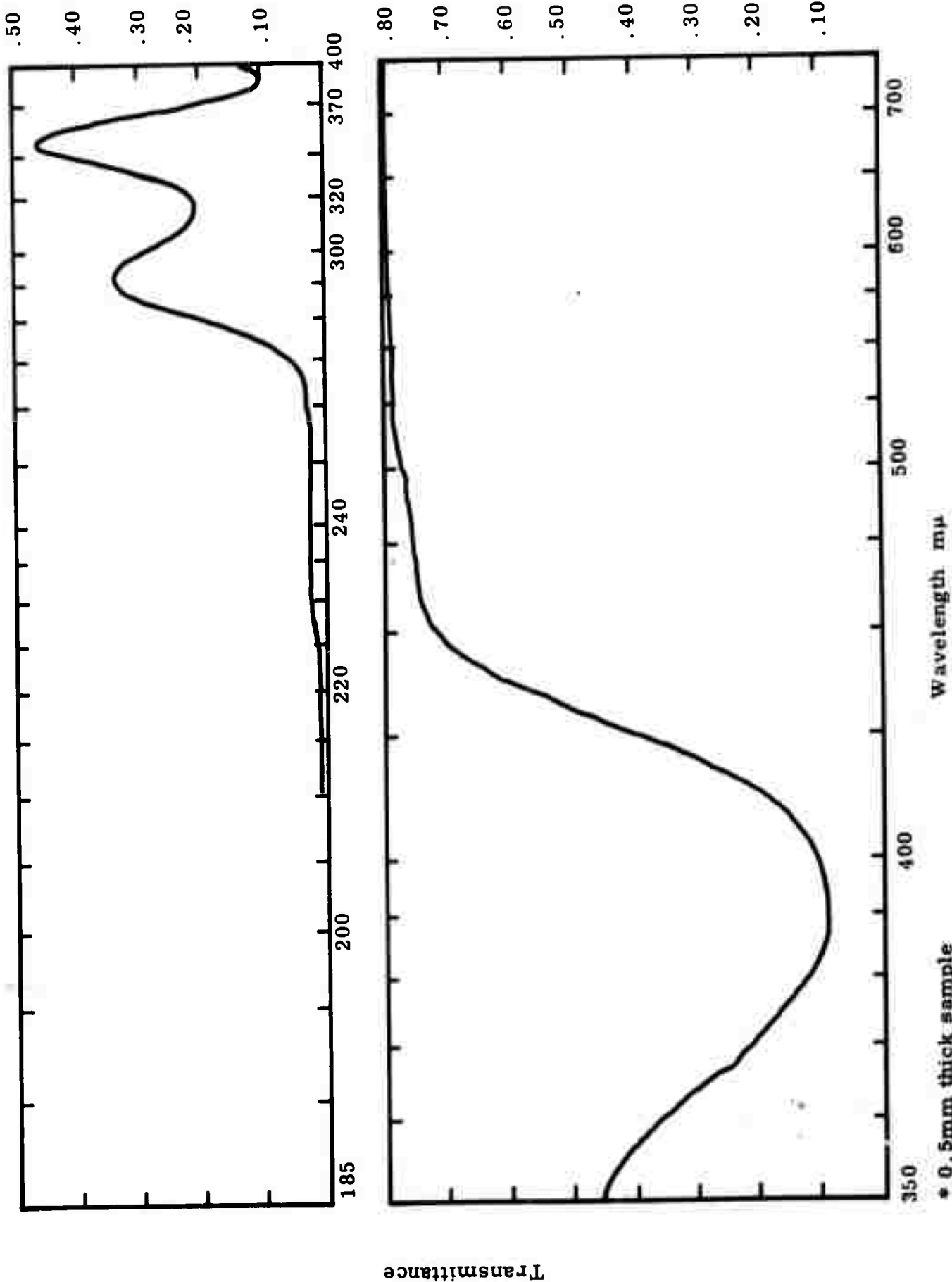

Figure 12. Transmission of Rhodium in Al_2O_3

Diffusion of rhodium into sapphire was accomplished by heating a ceramic Al_2O_3 rod in contact with rhodium metal to 1800°C for several hours. When taken apart, the ceramic piece fluoresced the band typical of Rh^{3+} . No estimate was made of the depth of the rhodium diffusion because this will be affected by the presence of ceramic grain boundaries. A similar experiment was conducted using a single crystal rod of sapphires. In this case no fluorescence was observed indicating that the diffusion of rhodium into the ceramic was a grain boundary or impurity phenomena.

In order to determine if rhodium could be incorporated into Czochralski sapphire, Rh_2O_3 was mixed with Al_2O_3 powder and the mixture was melted in an iridium crucible in a semi-oxidizing atmosphere. No fluorescence was seen from the cooled frozen melt. It appears that Rh^{3+} dissociates to metal even in the sapphire melt under moderate oxygen pressures.

Since it appears that Al_2O_3 : Rh can only be prepared at temperatures below 1300 - 1400°C , methods other than melt growth were considered. Vapor growth was considered using the method of Schaffer²⁴ which relies on the oxidation of AlCl_3 , however, this technique must operate at 1800 - 1900°C . We have grown sapphire sheets by the oxidation of AlF_3 at temperatures from 1000 to 1400°C . The Al_2O_3 was grown at the mouth of crucible containing Al_2O_3 - PbF_2 mixtures by the reaction $\text{Al}_2\text{O}_3 + 3\text{PbF}_2 \longrightarrow 2\text{AlF}_3 + 3\text{PbO} \xrightarrow{202} \text{Al}_2\text{O}_3 + 6\text{F}$. We know that the reaction $2\text{AlF}_3 + 3\text{PbO} \rightarrow \text{Al}_2\text{O}_3 + 3\text{PbF}_2$ does not occur because attempts to grow sapphire in sealed platinum tubes by this method did not produce transport and growth of sapphire.

Sapphire was vapor grown from Al_2O_3 - PbF_2 mixtures to which Rh_2O_3 had been added. Despite the fact that RhF_3 has a sublimation point²⁵ of 600°C no rhodium was found in the vapor grown sapphire.

Trivalent rhodium was incorporated into GdAlO_3 , ZnAl_2O_4 , and $\text{Gd}_3\text{Ga}_5\text{O}_{12}$ grown by the flux method. Emission was seen at 5680\AA in the

GdAlO₃ and at 6450Å in ZnAl₂O₄. The linewidths of these bands were measured to be 3000 cm⁻¹ and 2200 cm⁻¹ respectively. The fluorescent lifetime of rhodium was not measured because the fluorescence was very weak. Other hosts for rhodium were explored, some of which included larger ions. These were In₂O₃, Ga₂O₃, LaGaO₃, Ca₁₂Al₁₄O₃₃, CaGa₂O₄ and Ba₂YNbO₆. None of these fluoresced with rhodium doping.

3.2.6 V⁴⁺

Attempts were made to introduce V⁴⁺ into sapphire by charge compensating with Mg²⁺. A crystal grown by flame fusion containing 0.1% vanadium and 0.1% magnesium showed absorptions typical of both V³⁺ and V⁴⁺. Emission was seen at 1.22μ (1600 cm⁻¹ wide). Other hosts for V⁴⁺ which were explored were: ZrSiO₄, Gd₃Ga₅O₁₂, Y₃Al₅O₁₂, TiO₂ and SrTiO₃. The latter is a symmetric host which might be expected to give longer fluorescent lifetime. However no fluorescence was observed from vanadium in these hosts in the infrared.

3.3 CONCLUSIONS

The spectra of a number of transition metals have been studied in the visible and near infrared. Those exhibiting interesting fluorescence properties for high energy storage are Mn²⁺, Rh³⁺, and Cr³⁺. The emission wavelength, linewidth, and fluorescent lifetime (where determined), are summarized in Table VII. The manganese hosts and the ZnWO₄:Cr can be obtained by the Czochralski technique. The Al₂O₃:Rh³⁺ can only be grown by the flux technique and is available in small crystals only.

TABLE VII

FLUORESCENT PROPERTIES OF SOME TRANSITION METAL IONS

| <u>ION</u> | <u>HOST</u> | <u>$\lambda(\text{\AA})$</u> | <u>$\Delta\lambda(\text{\AA})$</u> | <u>$\tau$ (msec)</u> |
|------------------|---|---|---|---------------------------------|
| Mn ²⁺ | Y ₃ A1 ₅ O ₁₂ | 5900 | 490 | |
| | Ca ₁₂ A1 ₁₄ O ₃₃ | 6050 | 610 | |
| | CaGa ₂ O ₄ | 5715 | 570 | |
| | CaGa ₂ O ₇ | 5785 | 500 | |
| Rh ³⁺ | Al ₂ O ₃ | 6290 | 770 | 0.24 |
| | Al ₂ O ₃ (77°K) | 6320 | 770 | 0.58 |
| Cr ³⁺ | ZnWO ₄ | 1.04 μ | 1240 \AA | 0.020 |
| | ZnWO ₄ (77°K) | 1.04 μ | 1240 \AA | 0.080 |

REFERENCES

- ¹P. P. Sorokin and M. J. Stevenson, "Advances in Quantum Electronics II," Columbia University Press (1961).
- ²R. C. Duncan and Z. J. Kiss, Appl. Phys. Letters, 3, 23 (1963).
- ³Z. J. Kiss and R. C. Duncan, Jr., Proc. IRE, 50, 1531 (1962).
- ⁴F. K. Fong, J. Chem. Phys., 41, 245 (1964).
- ⁵H. Guggenheim and J. U. Kane, Appl. Phys. Letters, 4, 172 (1964).
- ⁶Semiannual Progress Report for Contract AF 33(657)11221, January 21, 1964.
- ⁷P. F. Weller, Inorganic Chemistry, 4, 1545 (1965).
- ⁸W. M. Latimer, "The Oxidation States of the Elements and Their Potentials in Aqueous Solutions," Prentice-Hall, Inc. (1952).
- ⁹T. Moeller, "The Chemistry of the Lanthanides," Reinhold Publishing Corp., (1963).
- ¹⁰L. H. Brixner, J. Am. Cer. Soc., 112, 625 (1965).
- ¹¹V. H. Schwarz and D. Bommert, Zeit fur Nat. 19b, 955, (1964)
- ¹²T. H. Maiman, Nature, 187, 493 (1960).
- ¹³L. F. Johnson, R. E. Dietz, and H. J. Guggenheim, Phys. Rev. Letters, 11, 318 (1963).
- ¹⁴L. F. Johnson, R. E. Dietz and H. J. Guggenheim, Appl. Phys. Letters, 5, 21 (1964).
- ¹⁵L. F. Johnson, and H. J. Guggenheim, 1966 International Quantum Electronics Conference Paper 6C-1, April 13, 1966.
- ¹⁶R. Pappalardo, D. L. Wood and R. C. Linares, J. Chem. Phys. 35, 2041 (1962).
- ¹⁷J. Jeevartam and F. P. Glasser, J. Am. Cer. Soc., 44, 564 (1961).

REFERENCES (Continued)

- ¹⁸R.C. Ohlmann, Final Technical Summary Report for Contract Nonr-4658(00). October, 1965
- ¹⁹L.F. Johnson, (unpublished data).
- ²⁰L.H. Brixner, J. Electro. Chem. Soc., 111, 690 (1964).
- ²¹S.E. Kurtz and W.G. Nilsen, Phys. Rev., 128, 1586 (1962).
- ²²L.G. Van Uitert and S. Preziosi, J. Appl. Phys., 33, 2908 (1962).
- ²³R.C. Linares, J. Appl. Phys., 33, 1747 (1962).
- ²⁴P.S. Schaffer, Evaluation of Vapor Deposition Growth of Oxide Single Crystals from Metal Halides, Final Report, Contract No. Nonr 4574(00), May 1965.
- ²⁵N.V. Sidwick; The Chemical Elements and Their Compounds, Oxford Press, 1950, p. 1518.

| DOCUMENT CONTROL DATA - R&D | | |
|---|--|-----------------------|
| <i>(Security classification of title, body of abstract and indexing annotation must be entered when the overall report is classified)</i> | | |
| 1. ORIGINATING ACTIVITY (Corporate author) The Perkin-Elmer Corporation Electro-Optical Division Norwalk, Connecticut | 2a. REPORT SECURITY CLASSIFICATION Unclassified | |
| | 2b. GROUP | |
| 3. REPORT TITLE EVALUATION OF OXIDE LASER HOSTS | | |
| 4. DESCRIPTIVE NOTES (Type of report and inclusive dates) Final Technical Summary Report (For the Period Ending 31 October 1966) | | |
| 5. AUTHOR(S) (Last name, first name, initial) Linares, Robert C. | | |
| 6. REPORT DATE 30 November 1966 | 7a. TOTAL NO. OF PAGES 36 | 7b. NO. OF REFS 25 |
| 8a. CONTRACT OR GRANT NO. Nonr 4660(00) | 9a. ORIGINATOR'S REPORT NUMBER(S) 8587 | |
| b. PROJECT NO. ARPA Order No. 306-72 | | |
| c. TASK Project Code No. 4730 | 9b. OTHER REPORT NO(S) (Any other numbers that may be assigned this report) | |
| d. | | |
| 10. AVAILABILITY/LIMITATION NOTICES Qualified requestors may obtain copies of this report from the Defense Documentation Center, Cameron Station Building, Alexandria 14, Virginia | | |
| 11. SUPPLEMENTARY NOTES | 12. SPONSORING MILITARY ACTIVITY Department of the Navy, Office of Naval Research, Washington, D.C. 20360 | |
| 13. ABSTRACT The optical spectra and crystal growth of a wide number of hosts were studied to determine their potential usefulness as laser materials. Two types of ions were studied because of their known broad, efficient, absorption and emission bands: divalent rare earths and transition metals. The stabilization of divalent rare earths in a large number of oxide crystals was studied with the emphasis on Sm^{2+} . The host crystal cations were selected because of their theoretical stability with divalent rare earths, however, only the combination of Eu^{2+} in $\text{Y}_3\text{Al}_5\text{O}_{12}$ was found to be stable. The transition metals (Sb^{3+} , Bi^{3+} , Co^{2+} , Ni^{2+} , Mn^{2+} , Cr^{3+} and RH^{3+}), were studied in divalent and trivalent hosts. The emission spectra were measured on all samples at room temperature and at liquid nitrogen temperature, and, in cases where good crystals were available, transmission measurements were made. Fluorescent lifetime and excitation spectra were measured where samples had sufficient intensity. Of the materials measured only $\text{ZnWO}_4:\text{Cr}$ had good spectral properties and could be grown easily. Large crystals of $\text{ZnWO}_4:\text{Cr}$ were grown and fabricated for laser testing. | | |

| 14. KEY WORDS | LINK A | | LINK B | | LINK C | |
|---|--------|----|--------|----|--------|----|
| | ROLE | WT | ROLE | WT | ROLE | WT |
| <p>Efficient Absorbers</p> <p>High Energy Storage Emitters</p> <p>Divalent Rare Earths</p> <p>Transition Metals</p> | | | | | | |

INSTRUCTIONS

1. ORIGINATING ACTIVITY: Enter the name and address of the contractor, subcontractor, grantee, Department of Defense activity or other organization (*corporate author*) issuing the report.

2a. REPORT SECURITY CLASSIFICATION: Enter the overall security classification of the report. Indicate whether "Restricted Data" is included. Marking is to be in accordance with appropriate security regulations.

2b. GROUP: Automatic downgrading is specified in DoD Directive 5200.10 and Armed Forces Industrial Manual. Enter the group number. Also, when applicable, show that optional markings have been used for Group 3 and Group 4 as authorized.

3. REPORT TITLE: Enter the complete report title in all capital letters. Titles in all cases should be unclassified. If a meaningful title cannot be selected without classification, show title classification in all capitals in parenthesis immediately following the title.

4. DESCRIPTIVE NOTES: If appropriate, enter the type of report, e.g., interim, progress, summary, annual, or final. Give the inclusive dates when a specific reporting period is covered.

5. AUTHOR(S): Enter the name(s) of author(s) as shown on or in the report. Enter last name, first name, middle initial. If military, show rank and branch of service. The name of the principal author is an absolute minimum requirement.

6. REPORT DATE: Enter the date of the report as day, month, year, or month, year. If more than one date appears on the report, use date of publication.

7a. TOTAL NUMBER OF PAGES: The total page count should follow normal pagination procedures, i.e., enter the number of pages containing information.

7b. NUMBER OF REFERENCES: Enter the total number of references cited in the report.

8a. CONTRACT OR GRANT NUMBER: If appropriate, enter the applicable number of the contract or grant under which the report was written.

8b, 8c, & 8d. PROJECT NUMBER: Enter the appropriate military department identification, such as project number, subproject number, system numbers, task number, etc.

9a. ORIGINATOR'S REPORT NUMBER(S): Enter the official report number by which the document will be identified and controlled by the originating activity. This number must be unique to this report.

9b. OTHER REPORT NUMBER(S): If the report has been assigned any other report numbers (*either by the originator or by the sponsor*), also enter this number(s).

10. AVAILABILITY/LIMITATION NOTICES: Enter any limitations on further dissemination of the report, other than those imposed by security classification, using standard statements such as:

- (1) "Qualified requesters may obtain copies of this report from DDC."
- (2) "Foreign announcement and dissemination of this report by DDC is not authorized."
- (3) "U. S. Government agencies may obtain copies of this report directly from DDC. Other qualified DDC users shall request through _____."
- (4) "U. S. military agencies may obtain copies of this report directly from DDC. Other qualified users shall request through _____."
- (5) "All distribution of this report is controlled. Qualified DDC users shall request through _____."

If the report has been furnished to the Office of Technical Services, Department of Commerce, for sale to the public, indicate this fact and enter the price, if known.

11. SUPPLEMENTARY NOTES: Use for additional explanatory notes.

12. SPONSORING MILITARY ACTIVITY: Enter the name of the departmental project office or laboratory sponsoring (*paying for*) the research and development. Include address.

13. ABSTRACT: Enter an abstract giving a brief and factual summary of the document indicative of the report, even though it may also appear elsewhere in the body of the technical report. If additional space is required, a continuation sheet shall be attached.

It is highly desirable that the abstract of classified reports be unclassified. Each paragraph of the abstract shall end with an indication of the military security classification of the information in the paragraph, represented as (TS), (S), (C), or (U).

There is no limitation on the length of the abstract. However, the suggested length is from 150 to 225 words.

14. KEY WORDS: Key words are technically meaningful terms or short phrases that characterize a report and may be used as index entries for cataloging the report. Key words must be selected so that no security classification is required. Identifiers, such as equipment model designation, trade name, military project code name, geographic location, may be used as key words but will be followed by an indication of technical context. The assignment of links, rules, and weights is optional.