

UNCLASSIFIED

AD NUMBER

AD805095

LIMITATION CHANGES

TO:

Approved for public release; distribution is unlimited.

FROM:

Distribution authorized to U.S. Gov't. agencies and their contractors; Critical Technology; OCT 1966. Other requests shall be referred to Office of Naval Research, ATTN: 468, Arlington, VA 22217. This document contains export-controlled technical data.

AUTHORITY

ONR ltr dtd 9 Nov 1977

THIS PAGE IS UNCLASSIFIED

THIS REPORT HAS BEEN DELIMITED
AND CLEARED FOR PUBLIC RELEASE
UNDER DOD DIRECTIVE 5200.20 AND
NO RESTRICTIONS ARE IMPOSED UPON
ITS USE AND DISCLOSURE.

DISTRIBUTION STATEMENT A

APPROVED FOR PUBLIC RELEASE;
DISTRIBUTION UNLIMITED.

AD No. _____

UNCLASSIFIED

805095



NAVSO P-970

REPRINTED FROM

U.S. NAVY JOURNAL of

UNDERWATER ACOUSTICS

Volume 16, No. 4

October 1966

This document is subject to special export controls, and each transmittal to foreign governments or foreign nationals may be made only with prior approval of Office of Naval Research (Code 468), Washington, D.C. 20360.

UNCLASSIFIED

When this article is referenced in unclassified reports or articles or listed in unclassified bibliographies (except TAB), indexes, etc., the citation should give the author and title followed by: In "Unpublished Report," Office of Naval Research, Code 468, and date (month and year) of the particular issue involved.

BLANK PAGE

UNCLASSIFIED

THE SOUND VELOCIMETER AT SEA—PERFORMANCE AND LIMITATIONS*

Ants T. Piip

Columbia University Geophysical Field Station
St. David's, Bermuda†

ABSTRACT

The design and operation of a precision in situ depth-temperature-sound-speed measurement system containing two velocimeters is described, including procedures used to ensure reliability and accuracy of results. Two instruments side-by-side make any irregularities in the operation of the velocimeters evident. Using different pairs out of three instruments at successive stations identifies both the error and its source. The individual readings can then be corrected to improve accuracy and confidence in the final result, the average of the two instruments. Extensive field use has shown the velocimeters to be reliable 90-95 percent of the time the two instruments have been tracking to within 15 cm/sec. Occasionally erratic behavior is observed; some cases are undetectable using only one instrument. Among the irregularities in the operation of a velocimeter are the following: changes in calibration after field use; the "15-cycle jump"; persistent, pressure-dependent calibration errors in some instruments; and sporadic short periods of instability when submerged in regions of rapid temperature change. An analysis of error sources and magnitudes shows the susceptibility of delay time to thermal transients. A comparison between Nansen bottles and velocimeters shows the accuracies of derived sound speeds to be similar, the velocimeter yielding continuous data and being more suitable for surveys, or microstructure work. It is estimated that present-day velocimeters results can be accurate to ± 10 cm/sec in properly interpreted multi-instrument systems.

INTRODUCTION

In the past few years, we have been involved in a rather extensive acoustics-oriented program investigating the fine structure and stability of the deep oceanic waters. We have been using sound velocimeters for this purpose since sound speed is a parameter that can be measured rapidly and accurately, and depends strongly on temperature and salinity. Initially our main emphasis was on variability. Figure 1 illustrates this point: It is a composite of three multi-profile sound-speed stations taken at 2-week intervals at the same site. The changes, even during one station, are seen to be so large that a slight, but stable uncertainty in absolute values is immaterial.

From the beginning we used two velocimeters side-by-side to make sure that the variations and fine structure we saw were not caused by erratic instrument behavior.¹ Over 3-4 years, during which we have made over 90 stations and 400 profiles around Bermuda, the

*Presented at the ONR Workshop on "The Direct Measurement of Sound Speed in Sea Water," 21-22 June 1966, Washington, D.C. 20360. (Lamont Geological Observatory Contribution No. 946.)

†Navy SOFAR Station, APO New York 09856.

¹A. Piip, "Fine Structure and Stability of the Sound Channel in the Ocean," J. Acoust. Soc. Am. 36, 1948-53 (1964).

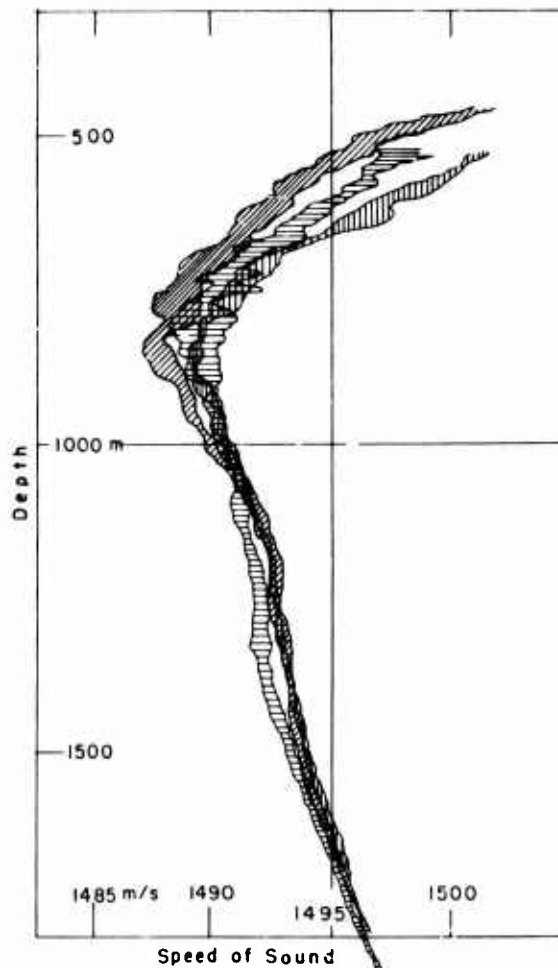

Fig. 1. Composite of three multiple-profile sound velocity stations at 2-week intervals, at the same location 100 miles NE of Barbuda

Bahamas, the Lesser Antilles² and from the Canaries to England, our system has evolved through several equipment generations, our methods have been refined and improved, and our accuracy is approaching the limit of the instruments. We now get a continuous sound-speed-temperature-depth profile to over 2000 meters depth in less than an hour, with readings about every 3 meters, and good to ± 10 cm/sec from the standard used in calibrating the instruments.³

INSTRUMENTATION

Figure 2 is a simplified block diagram of our system. The underwater package contains two NBS-type velocimeters⁴ (channels 2 and 3), a precision pressure gauge with FM output

²A. Piip, "Precision Sound Velocity Profiles in the Ocean; Vol. I -- The Sound Channel in the Bermuda-Barbados Region, November-December 1963," Lamont Geological Observatory Technical Report No. 3, CU-3-66 (1966).

³M. Greenspan and C. E. Tschigg, "Speed of Sound in Water by a Direct Method," J. Res. Nat. Bur. Stds. 59, 249 (1957).

⁴C. E. Tschigg and E. E. Hays, "Transistorized Velocimeter for Measuring the Speed of Sound in the Sea," J. Acoust. Soc. Am. 31, 1038 (1959).

UNCLASSIFIED

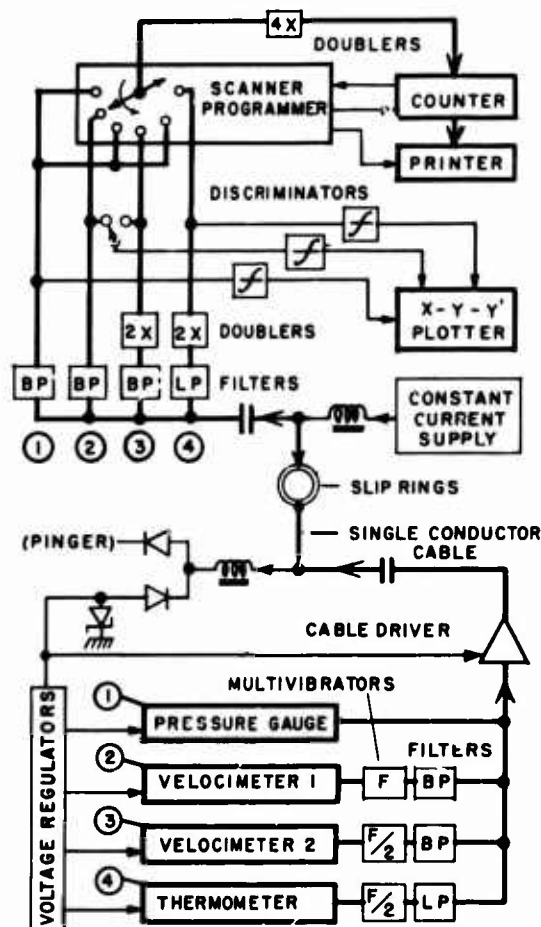

Fig. 2. Simplified block diagram of two-velocimeter depth-sound-speed-temperature system (channel numbers in circles)

(channel 1) and a FM-output platinum resistance thermometer (channel 4). Each instrument is fed by an individual voltage regulator. Our basic velocimeter is a modified TR-2. We take the output pulses from the pulse generator, at about 7 kHz pulse repetition frequency (prf), without going through the frequency halving square wave generator usually provided, and use these as our signal. The output of velocimeter 1 goes to a monostable multivibrator and is converted to a square wave at the basic pulse repetition frequency. The output frequencies of velocimeter 2 and the thermometer are first halved, to eliminate any frequency overlap in the telemetering channels. The square waves are filtered, and the outputs of all four channels are mixed in a low-distortion summing amplifier and sent up the cable.

On shipboard, the composite signal is separated into its component channels and multiplied by means of push-push doublers to four times the basic instrument frequencies. The channels are scanned, a second for each, in a 1-2-1-3-1-4 sequence and the frequency counts are printed on paper tape.

A constant-current supply supplies power to the underwater instrument package via the same single-conductor double-armoured cable that takes the instrument outputs topside and serves as the suspension line.

Provision is made in the system to operate a pinger, for periodic checks on the pressure gauge. When a pinger is used, it is activated by reversal of line polarity.

DATA: VALIDATION AND PROCESSING

The two-pen X-Y plotter in the instrument system serves as a quick-look device, recording temperature and either of the two velocimeter outputs versus pressure.

As a check of the proper operation of the two velocimeters, short sections from the numerical printout of each profile are handplotted for the surface, sound channel and deep regions. The separation of the two traces is compared to the separation of the calibration curves for each instrument. Normally, when both instruments are operating properly, they track to within 10-15 cm/sec. Any abnormal deviations in trace separation indicate a malfunction in one of the instruments. Sometimes the bad one can be identified just by inspection of its behavior. If not, using different pairs of three or more available velocimeters at successive stations makes it possible to identify both the type of irregularity and the offending instrument. In this fashion we have found cases of erratic instrument behavior which could cause serious errors in results, but would have been impossible to detect using just one velocimeter.

After the velocimeter outputs have been validated and any necessary corrections to their readings or calibrations determined, the data are prepared for computer reduction and processed both for numerical output printout and machine-drawn plots of temperature and the two sound-speed profiles. The two sound-speed profiles are averaged visually, with minor corrections where required, to yield a single profile as a final result. The final accuracy is estimated to be about ± 10 cm/sec, resolution and precision ± 5 cm/sec.

We standardize our velocimeter data to $+10^\circ\text{C}$ ambient, mainly because (1) this is a physically common temperature in the middle of the normal range of operations, and (2) applying direct corrections according to the instantaneous ambient temperature is not always justified in fast lowerings or raisings: the effective instrument temperature lags behind the ambient. (The time constant of an airfilled instrument is close to 10 minutes. This could be reduced by filling the pressure case with a suitable, inert insulating liquid, which also would make an accidental pressure leak relatively harmless.)

VELOCIMETERS

Calibration

Our velocimeters are normally calibrated before and after each cruise, if possible. During calibration runs the velocimeters are totally immersed in a distilled water bath. In each run, several 10-second counts are taken at approximately every 2°C , first making sure that the temperature and velocimeter readings have reached a steady state at each point. The extreme bath temperatures are chosen so that they range from below the lowest temperature encountered in the sea to one giving a sound-speed in distilled water higher than the highest at sea. In this interval, the instruments must operate without any sign of abnormality. The calibration values are referred to the last previous calibration and the difference plotted. This procedure hugely magnifies any changes in calibration and gives an immediate idea of the instrument's performance. If the calibration is satisfactory, a least squares fit is obtained and new calibration figures are determined.

The calibration history of three velocimeters over 2 years is illustrated in Table I. Between each of the several calibration runs the instruments had seen field use. The table gives the amounts by which the readings would have been in error if the initial calibrations had been used all the time. The observed shifts are random in character.

The table is based on calibration figures as used in the field, where we measure frequencies to ± 0.25 Hz. This makes the errors appear quantized in 5.2-cm/sec steps.

UNCLASSIFIED

TABLE I. Calibration History of Three TR-2
Velocimeters Referred to Initial Calibrations
(Selected calibration runs over 2 years)

| Instrument | Calibration | 1490 m/sec | 1520 m/sec |
|------------|-------------|------------|------------|
| 2 | 1 | ±00 | ±00 |
| | 2 | +21 cm/sec | +36 cm/sec |
| | 3 | +21 | +21 |
| | 4 | +10 | +21 |
| | 5 | +36 | +52 |
| | 6 | +10 | +21 |
| 3 | 1 | ±00 | ±00 |
| | 3 | + 5 | +16 |
| 8 | 1 | ±00 | ±00 |
| | 2 | - 5 cm/sec | ± 0 cm/sec |
| | 3 | - 5 | - 5 |
| | 4 | -31 | -31 |

It might be mentioned that we do not try to determine the instrument "constants" (path length and delay time) in our calibrations. The effective delay time seems to depend too much on the points selected for its determination. We believe a direct sound-speed frequency calibration is more accurate and reliable.

Performance at Sea

Our usual procedure at sea is to take several consecutive profiles at each station. Below the thermocline, we try to keep winch speed around 1 m/sec, somewhat slower in the sound channel and the surface layers.

We have never observed any significant differences between down and upgoing profiles that could be attributed to the instruments or the system, when operating properly: the differences can always be explained by the actual variations inherent in the sea. Our velocimeters are entirely open to the surrounding water, with no chance of pocket formation.

In addition to profiles, we have taken a number of constant depth recordings around the foot of the thermocline of up to over 30 hours duration, keeping the depth of the instruments constant to within a few meters. Tracking of the two velocimeters has been excellent under these conditions of nearly constant temperature, an order of magnitude better than the fluctuations of the medium. A very high degree of correlation has been observed between the temperature and sound speed traces, completely overriding any effect from depth variations.

About 90-95 percent of the time our velocimeters have been well-behaved and tracking normally. Occasionally, one of the two instruments has been observed to behave strangely.

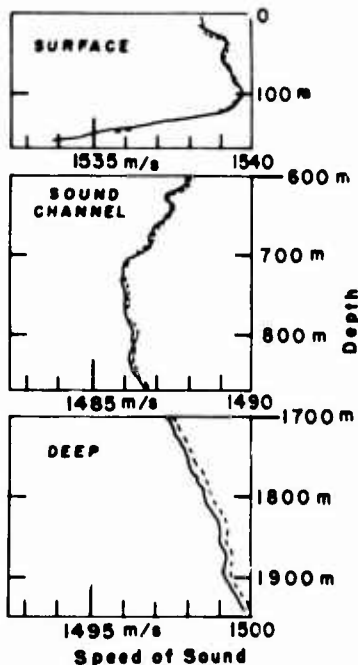

Fig. 3. Deterioration of tracking of two velocimeters because of abnormal pressure sensitivity of one instrument

Types of Instrument Error

The "15-cycle jump," caused by the trigger point sliding from one hf cycle to the next, has been observed only once or twice. Proper adjustment of the sound path and electronics virtually eliminates its occurrence. If it should occur, it can be easily detected by inspection of the complete sound speed profile, even in the case of a single velocimeter.

More disturbing are two other types of erratic behavior that we have observed; these would be undetectable in a single-instrument installation.

Figure 3 illustrates the case of an excessively pressure-sensitive velocimeter. Near the surface, tracking of the two instruments is normal, but at greater depths the traces gradually begin to separate, until at around 2000 m depth they differ by about 30 cm/sec. This effect is persistent and reversible, appearing on all down-and-up profiles of this combination of velocimeters. A plausible explanation for this behavior is that the transducers proper exhibit properties under pressure which are different in the two instruments. The two mechanically identical velocimeters track perfectly on the bench, and pressure corrections due to bowing of the sound path as mounted on the endcap of the instrument case amount only to 6 cm/sec for a depth of 2000 m.

Figure 4 shows the top 500 meters of a series of consecutive profiles taken to nearly 2000 m depth. The heavy arrows indicate the direction of motion of the instrument package. Profile 2 is normal in all respects, the two velocimeters track satisfactorily coming through the top of the thermocline into constant-temperature surface waters. Profile 3, following immediately afterwards, starts out with one of the instruments suddenly reading nearly 2 m/sec too high. This separation persists until the instruments are back in deeper and colder waters, and then it diminishes gradually. Although not shown, the instruments regain good tracking at greater depth, and track well until they again arrive close to the surface, through the thermocline (profile 4). This curious behavior did persist thereafter for several consecutive lowerings and raisings, until it was detected and the offending instrument replaced with a good one.

This is not a case of a "15-cycle jump," as can be seen from the top 100 meters of profile 4. It is a smooth drift over about 2 minutes, between 0055 and 0057 in profile 4 (this must also have happened between 2305 and 2309, during the turnaround between profiles 2 and 3, when no recordings were made). Also, the gradual drift back to normal calibration does not agree with the quantized character of the instrument trigger point jumping from one hf cycle to the next. It could be caused by transient differential thermal effects in the electronics: although the instrument might retain its calibration under steady-state thermal conditions, its different parts and components still exhibit different thermal time constants. Until thermal equilibrium has been reached, transient effects show up.

To prove this point, we have made a few crude attempts to observe the velocimeters under thermal shock conditions (Fig. 5). Three instruments were cooled overnight in a refrigerator to about $+6^{\circ}\text{C}$ and quickly immersed (with the sound paths in a vertical plane) in an underground water tank containing several thousand gallons of rainwater at 25°C (a typical Bermuda water tank). Two instruments, known to be in good operating condition, after a short but large initial transient reached steady-state in less than 20 minutes; in a poorly aligned instrument, operating at very low signal level, the transient lasted nearly 2 hours. A similar situation probably

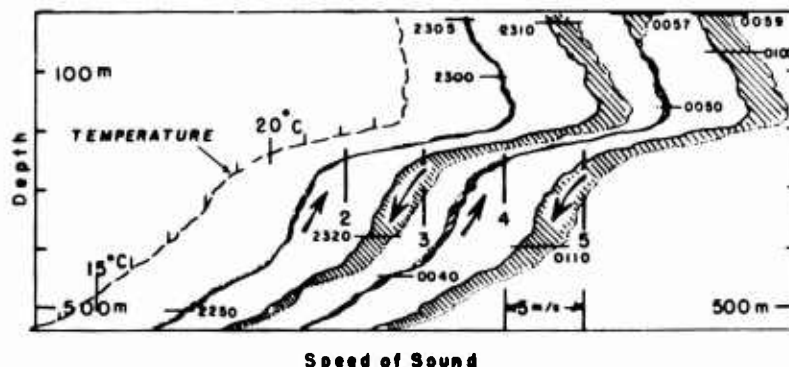

Fig. 4. Erratic functioning of a velocimeter in a region of high temperature gradients (solid line: good instrument, dotted line: erratic instrument. Heavy vertical bars on profiles: 1525 m/sec. Small numbers at horizontal ticks: time)

caused the malfunction of one instrument illustrated in Fig. 4. This instrument, although operating normally in a calibration run, also had hf amplitudes much lower than normal.

We have not been able to pinpoint the specific reason for the effect just described. After replacement of several suspect components in the circuitry, repacking of transducers and a thorough alignment process, the instruments were back to normal, and never have exhibited this behavior again.

Sources of Error

Table II is an attempt to explain the sources of some observed errors. Most of these probably are due to changes in the delay time.

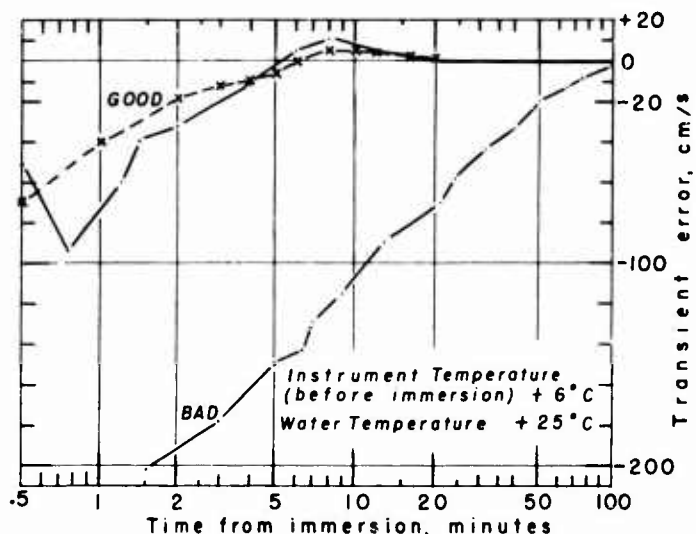

Fig. 5. Transient thermal effects in velocimeters after 19°C thermal shock

The total delay time in the instrument is determined partly by the transient behavior of the transmitting and receiving transducers and partly by electronic delays in the circuitry, again depending largely on transient pulse characteristics. All of these can be temperature-sensitive, each component to a different degree. The assumption of a constant delay time under all temperature and pressure conditions is hardly justified.

TABLE II. Instrument Error Parameters
in Terms of Sound-Speed

| | |
|--|------------|
| 1 hf period | 350 cm/sec |
| delay time | 600 |
| 1 Hz prf | 22 |
| 1° phase shift, hf | 1 |
| <u>10 percent amplitude change:</u> | |
| 15 percent overdrive (trigger at 60° hf) | 12 cm/sec |
| 1.5X overdrive (trigger at 45° hf) | 6 |
| 2 X overdrive (trigger at 30° hf) | 3 |
| 10 X overdrive (trigger at 6° hf) | 0.5 |
| <u>Ambient conditions:</u> | |
| 1°C Temperature (sound path) | 2 cm/sec |
| 1°C Temperature (electronics) | ? |
| 1000 m depth (sound path flat on endcap) | 3 |

The table pertains to an NBS-type instrument, model TR-2, with a path length of 20 cm, pulse repetition frequency of 7 kHz, and pulse frequency 3 MHz. The instrument is mounted in an airfilled pressure case, with the sound path folded flat on an enlarged endcap made of stainless steel.

In an instrument of this type a jump of the trigger point from one hf cycle to the next ("15-cycle jump") would introduce an error of 3.5 m/sec in the indicated sound speed. A 1-degree phase shift in the hf part causes a 1-cm/sec change in indicated sound speed. In simple semiconductor electronics, phase shifts of several degrees can be caused by quite small changes in temperature or operating point of the transistors. Likewise, ceramic transducer elements can exhibit changes of the same order of magnitude due to temperature or pressure changes.

The hf-pulse amplitude also has a considerable effect on the stability of the instruments. Depending on the amount of overdrive (ratio of effective actual hf amplitude to triggering amplitude), a minor amplitude change in the hf pulse can cause inordinately large errors. These errors become larger as the amplitudes get smaller, i.e., the trigger point slides upwards on the leading hf cycle, and can culminate in a jump across the peak of the wave. On the other hand, the trigger point cannot be set so low that it might run into the noise level.

The amplitude sensitivity of the instrument could also be decreased by using a higher transducer frequency to pulse repetition ratio.

The temperature and pressure dependence of the sound path, as listed in Table II, depend only on the choice of materials and mechanical design, and can easily be reduced to an insignificant amount.

VELOCIMETER VERSUS NANSEN BOTTLES

It might be instructive to compare the accuracy obtained in a well-interpreted multi-instrument velocimeter system to that obtained from high-quality Nansen bottle casts.

From Wilson's equation,⁵ the following (approximate) influences on sound speed can be obtained:

10 m depth \approx 17 cm/sec

0.1°C temperature \approx 36 cm/sec

0.1‰ S, salinity \approx 14 cm/sec

Assuming perfect sound speed tables and a depth determination uncertain by ± 5 m, temperature by $\pm 0.01^\circ\text{C}$, and salinity by $\pm 0.01\text{‰}$, the computed sound speed will be uncertain to $8.5 + 3.6 + 1.4 = 13.5$ cm/sec. This is no better than a good velocimeter reading.

In both cases, there is an additional source of uncertainty in determining the sound speed: in the case of a velocimeter, the sound-speed tables used to calibrate the instrument — in the case of bottle casts, the tables used in calculating sound speed from pressure, temperature, and salinity. Determination of accurate sound-speed values in distilled water, under controlled laboratory conditions, should be easier and more accurate than the construction of an equation or table for sea water under variable pressure, temperature, and salinity: all quantities whose determination is subject to some error, in addition to the difficulty of determining the sound speed under these conditions. The uncertainties in the readout of a well-behaved, state-of-the-art-velocimeter (or multi-instrument system) arising from pressure and temperature effects in the sea are believed to be smaller than those encountered in constructing sound speed tables for sea water. Consequently, a velocimeter in the sea cannot but give a truer measure of sound speed in the ocean than bottle data, provided its calibration is true: i.e., the calibration tables are accurate. In addition, the velocimeter is capable of giving continuous, rapid, repeated readings in a fraction of a time it takes to determine sound speeds at selected depths from bottle casts. It is a most convenient tool for fine structure determination of the oceanic waters, and for rapid surveys of the gross features of the oceans. With a good present-day depth-temperature-sound speed system salinity determination to $\pm 0.1\text{‰}$ S is quite realistic on an absolute basis. Microstructure, at reduced accuracy, can be resolved to smaller amounts.

SUMMARY AND CONCLUSIONS

The sing-around sound velocimeter remains a very useful oceanographic tool. In addition to purely acoustical uses, it seems to be the best available instrument for at least qualitative microstructure and stability investigations at sea. Good and reliable accuracies can be obtained by careful maintenance and alignment procedures. Regular calibrations and keeping the instruments in good working order are more important for good results than extremely accurate initial calibrations.

Properly interpreted multi-instrument systems can yield consistent accuracies to better than ± 10 cm/sec. This is better than what can be calculated from Nansen bottle casts.

Nearly as accurate results can be obtained from a single velocimeter, but there is hardly any way of telling whether the instrument has performed properly all the time. Thus, the reliability of single-instrument data is much lower, compared to multi-instrument systems.

Although the present-day sound velocimeter is trustworthy to a good degree most of the time, it sometimes behaves erratically without any apparent reason. It is to be hoped that

⁵W. D. Wilson, "Equation for the Speed of Sound in Sea Water," J. Acoust. Soc. Am. 32, 1357 (L) (1960).

future designs will be much more reliable, have electronics immune to thermal transients, and will not need so much constant care for good performance. It is by no means certain that the sing-around principle is the best approach.

ACKNOWLEDGMENTS

This paper is based on work performed under contract Nonr 266(65), sponsored by the Acoustics Branch (Code 468) of the Office of Naval Research.