

UNCLASSIFIED

AD NUMBER

AD805693

LIMITATION CHANGES

TO:

Approved for public release; distribution is unlimited.

FROM:

Distribution authorized to U.S. Gov't. agencies and their contractors; Critical Technology; DEC 1966. Other requests shall be referred to Rome Air Development Center, Griffiss AFB, NY 13440. This document contains export-controlled technical data.

AUTHORITY

RADC ltr, 14 Oct 1971

THIS PAGE IS UNCLASSIFIED

805693

RADC-TR-65-534, Volume II
Final Report



**INVESTIGATION OF PRECISION ANTENNA PATTERN
RECORDING AND DISPLAY TECHNIQUES, PHASE II**

Jack Chastain
Rexin E. Pidgeon, Jr.
Scientific-Atlanta, Inc.

**TECHNICAL REPORT NO. RADC-TR-65-534
December 1966**

**This document is subject to special
export controls and each transmittal
to foreign governments, foreign na-
tionals or representatives thereof may
be made only with prior approval of
RADC (ENLI), GAFB, N.Y. 12140**

**Rome Air Development Center
Research and Technology Division
Air Force Systems Command
Griffiss Air Force Base, New York**

When US Government drawings, specifications, or other data are used for any purpose other than a definitely related government procurement operation, the government thereby incurs no responsibility nor any obligation whatsoever; and the fact that the government may have formulated, furnished, or in any way supplied the said drawings, specifications, or other data is not to be regarded, by implication or otherwise, as in any manner licensing the holder or any other person or corporation, or conveying any rights or permission to manufacture, use, or sell any patented invention that may in any way be related thereto.

Do not return this copy. When not needed, destroy

BLANK PAGE

INVESTIGATION OF PRECISION ANTENNA PATTERN
RECORDING AND DISPLAY TECHNIQUES, PHASE II

Jack Chastain
Rezin E. Pidgeon, Jr.
Scientific-Atlanta, Inc.

**This document is subject to special
export controls and each transmittal
to foreign governments, foreign na-
tionals or representatives thereto may
be made only with prior approval of
RADC (EMLI), GAFB, N.Y. 13440**

FOREWORD

This technical report was prepared by Scientific-Atlanta, Inc., Atlanta, Georgia 30324 under contract AF30(602)-3425, project 4506, task 450604. The Rome Air Development Center Project Engineer is Mr. Martin Jaeger, EMATA. Secondary report number is J234-FR-II.

This technical report has been reviewed and is approved.

Approved: *Martin Jaeger*
MARTIN JAEGER
Project Engineer
Antenna & Coherent Optical Section

Approved: *Thomas S. Bond, Jr.*
THOMAS S. BOND, JR.
Colonel, USAF
Chief, Surveillance & Control Division

FOR THE COMMANDER

Irving J. Gabelman
IRVING J. GABELMAN
Chief, Advanced Studies Group

ABSTRACT

Volume II of the Final Report on equipment developed by Scientific-Atlanta, Inc., for RADC under Contract AF30(602)-3425 is presented. The contract was for development of equipment to enhance the antenna measurement capability of ground-based antenna test ranges, and for continuation of theoretical studies initiated under Contract AF30(602)-2737. The equipment developed and reported herein includes an amplitude- and frequency-stabilized signal source for the frequency range of 2 to 4 GHz and a precision, high-data-rate receiver system with logarithmic readout of data in digital and analog form. The theoretical studies reported in Volume I include an investigation of environmental effects and an analysis of parallax errors as related to high-accuracy antenna measurements; an investigation of antenna-positioning techniques and angle-measuring equipment; and a determination of optimum techniques for a high-speed precision recording system.

BLANK PAGE

TABLE OF CONTENTS

SECTION		PAGE NO.
1	INTRODUCTION	1-1
2	TRANSMITTER	2-1
	2.1 Design Objective	2-1
	2.2 Design Approach	2-1
	2.3 General Description	2-3
	2.4 Extension of Frequency Range	2-7
3	PRECISION AMPLITUDE MEASUREMENT RECEIVER SYSTEM	3-1
	3.1 Design Objectives	3-1
	3.2 Design Approach	3-1
	3.3 General Description	3-4
4	SYSTEM PERFORMANCE	4-1
	4.1 Transmitter	4-1
	4.2 Receiver	4-4
	4.3 Application of Measuring System	4-15
5	CONCLUSIONS AND RECOMMENDATIONS	5-1

LIST OF ILLUSTRATIONS

FIGURE		PAGE NO.
1	Technical Goals for RADC Precision Antenna Pattern Measurement Program	1-2
2	Photograph of Stabilized Signal Source	1-3
3	Photograph of Precision Amplitude Measurement Receiver System	1-4
4	Phase II Equipment Incorporated into RADC Antenna Pattern Measurement System	1-5
5	Block Diagram of Stabilized Signal Source	2-5
6	Principle of Digital Logarithmic Conversion	3-3
7	Block Diagram of Precision Amplitude Measurement Receiver System	3-6
8	Monitor Power Meter Indication for Rear RF Output of 0.5 Watt	4-2
9	Typical Maximum Output Power	4-3
10	Transmitter Power Stability Measured Over a Two-Hour Period	4-5
11	Typical Mean Error for IF Signal Levels Below (A) -41 dbm, (B) -35 dbm, and (C) -32 dbm	4-7
12	Typical RMS Count Fluctuation for IF Signal Levels Below -35 dbm A = Normal Mode; B = Average Mode	4-9
13	Typical Mean Error for 20 MHz to 1.95 GHz Signal Levels Below -22 dbm	4-10
14	Typical Mean Error for 1.95 GHz to 4.0 GHz Signal Levels Below -25 dbm	4-11
15	Typical Mean Error for 4.0 GHz to 8.0 GHz Signal Levels Below -25 dbm	4-12
16	Typical Mean Error for 8.0 GHz to 12.0 GHz Signal Levels Below -25 dbm	4-13
17	Typical Mean Error, 20 MHz to 12.0 GHz	5-2

9 Nov 66

1. The intent of this continuation effort was to investigate and develop advanced antenna test range instrumentation techniques applicable to the measurement of large narrow beamwidth antenna systems and to verify these techniques for use in a 0.2 to 12 GHz high speed precision antenna pattern measuring and recording system. The technical goals of the program included a substantial improvement in existing amplitude and angular measurement accuracies and a faster means of collecting and reducing accurate data. Experimental equipment developed was integrated into the USAF Antenna Proving Range, Newport, NY, to demonstrate operational feasibility under field conditions.

2. Three items were developed under this effort. The first item is an experimental model of a 2 to 4 GHz, half watt, frequency and amplitude stabilized transmitter approaching the performance of laboratory standards (frequency stability, one part per million per day; amplitude stability, 0.01 db per hour). The system employs phase locking and amplitude leveling to maintain the required frequency and amplitude stability for receiving system compatibility. The design of the 2 to 4 GHz transmitter is representative of the type of system which can be used at other bands in the 0.2 to 12 GHz frequency range with a minimum amount of additional development.

3. The second item developed is a 0.2 to 12 GHz amplitude measurement receiver system which represents a significant advancement in the art of precision antenna pattern measurement techniques (linearity approximately 0.04 db from 0 to -50 db and 0.3 db from -50 to -60 db). This represents an improvement of at least one order of magnitude over existing antenna pattern receivers. The superheterodyne receiver system employs harmonic mixing and up conversion techniques to achieve broad frequency coverage and a new logarithmic conversion technique to provide direct high speed decibel data readout in digital or analog form.

4. The third item developed is a one axis breadboard model of an antenna pattern recorder for providing three dimensional plots of an antenna radiation pattern at increased accuracy resolution and speed. The device fabricated which proved the basic feasibility of displaying character information at the rate of 100 samples per second is reported in RADC-TR-66-534, Vol I, Final Report, entitled, "Investigation of Precision Antenna Pattern Recording and Display Techniques", dated Feb 1966.

5. The results obtained from this effort met the minimum requirements and in many respects exceeded the specified design objectives. The techniques developed can be used for high precision measurements by both Government and commercial antenna development organizations.

Martin Jagger

MARTIN JAGGER
Project Engineer
RADC, GAFB, NY

1. INTRODUCTION

Contract AF 30(602)-3425 encompasses work by Scientific-Atlanta, Inc., for Rome Air Development Center, continuing work accomplished under Contract AF 30(602)-2737.* The contract is for development of equipment to enhance the antenna measurement capability of ground-based antenna test ranges, and for continuation of theoretical studies initiated under the prior contract. Figure 1 is a graphical presentation in system-block-diagram form of the technical goals for the overall RADC precision antenna pattern measurement program.

This report, which is Volume II of a two-volume final report, describes the equipment developed under Phase II and summarizes results of performance tests. The equipment developed includes an amplitude- and frequency-stabilized signal source for the frequency range of 2 to 4 GHz and a precision, high-data-rate receiver system with logarithmic readout of data in digital and analog form. The receiver system incorporates new logarithmic conversion techniques, which were investigated for feasibility under Phase I. Although the receiver system was designed primarily for the frequency range of 2 to 4 GHz, additional subunits were designed in the system to allow experimental evaluation over the frequency range of 0.2 to 12 GHz by using harmonic mixing and up-conversion techniques.

Photographs of the stabilized signal source (transmitter) and the precision amplitude measurement receiver system** (receiver) are given in Figures 2 and 3, respectively. A block diagram showing the equipment supplied under Phase II and incorporation of this equipment into the antenna measurement system is shown in Figure 4.

Included in Volume I of the final report are results of an investigation of environmental effects and an analysis of parallax errors as related to high-accuracy antenna measurements; an investigation of antenna-positioning and angle-measuring equipment; and a determination of optimum techniques for a high-speed precision recording system.

*In this report Contract AF 30(602)-3425 is referred to as Phase II; work under Contract AF 30(602)-2737 is referred to as Phase I.

**The precision amplitude measurement receiver system includes contract items designated as amplitude measurement receiver system, panoramic display unit, and digital-to-analog converter: for brevity, it is referred to in this report as receiver.

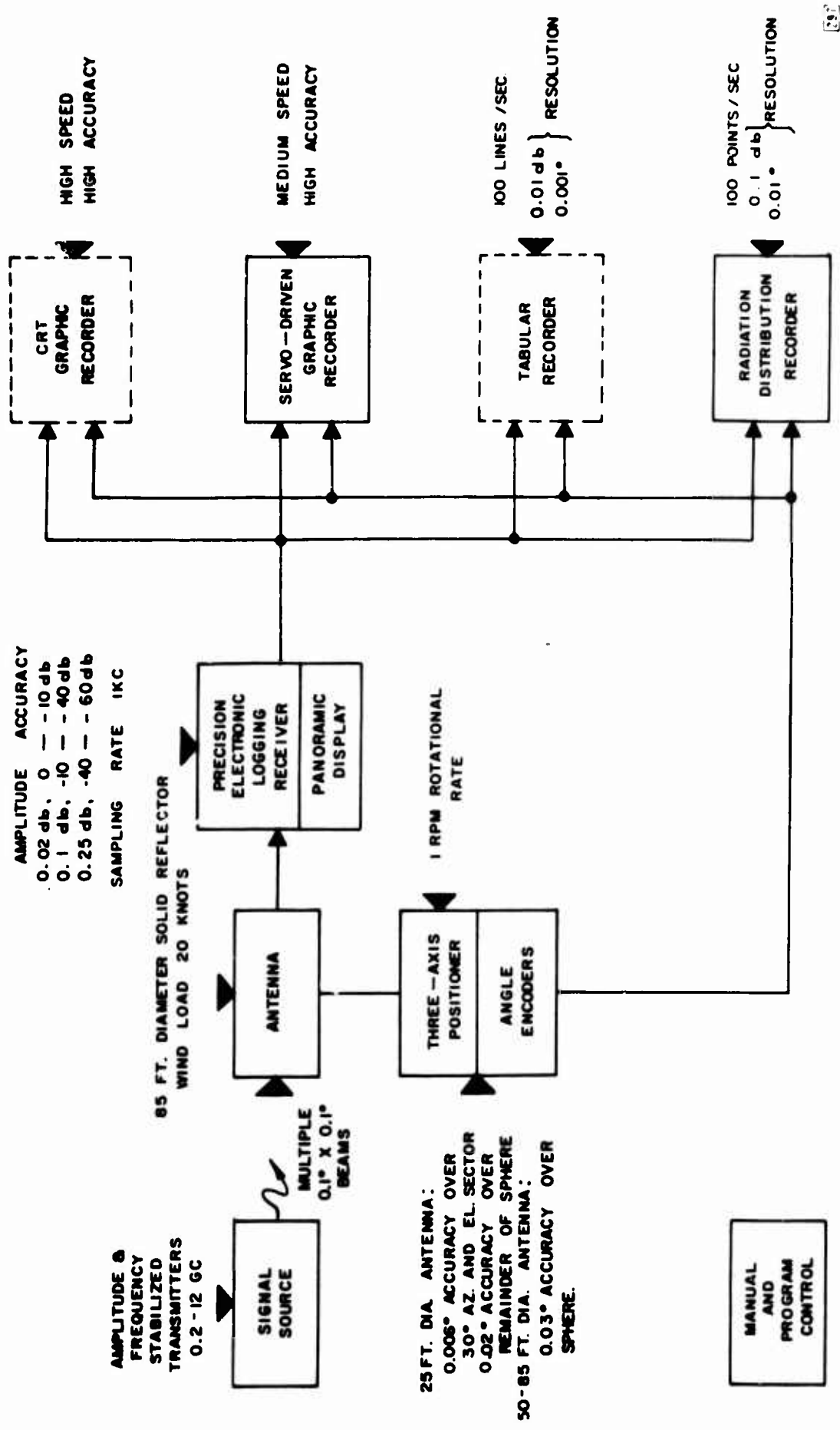

NOTE: EQUIPMENT ENCLOSED IN DASHED LINES INCLUDED IN BLOCK DIAGRAM FOR FUTURE CAPABILITIES.

Figure 1
Technical Goals for RADDC Precision Antenna Pattern Measurement Program

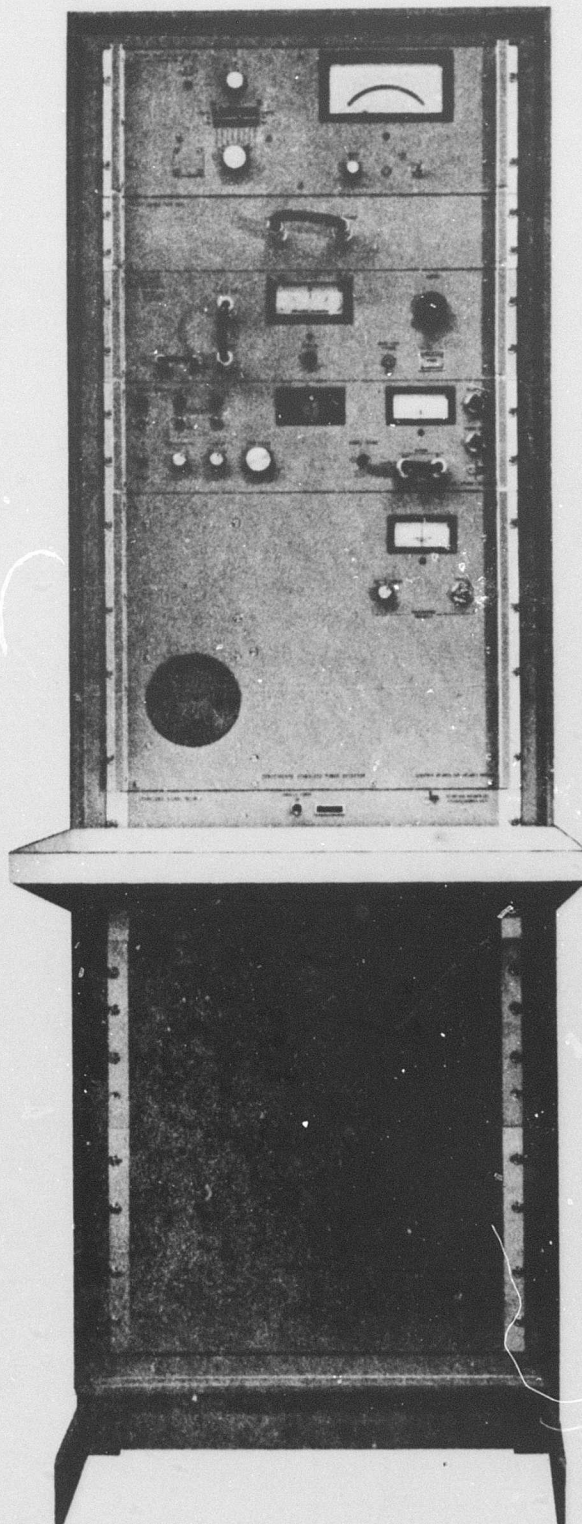

P2303

Figure 2
Photograph of Stabilized Signal Source

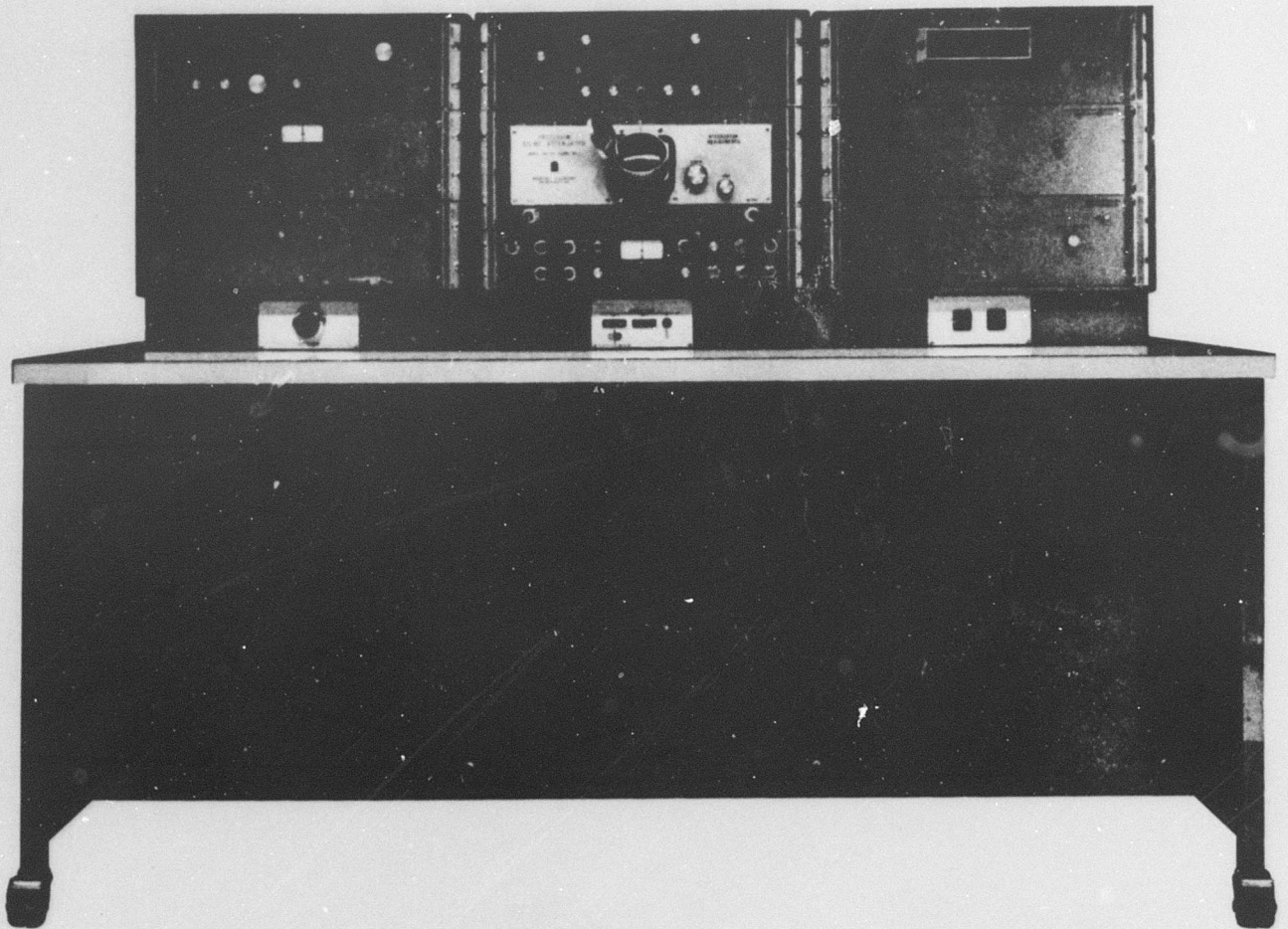

P2302

Figure 3
Photograph of Precision Amplitude Measurement Receiver System

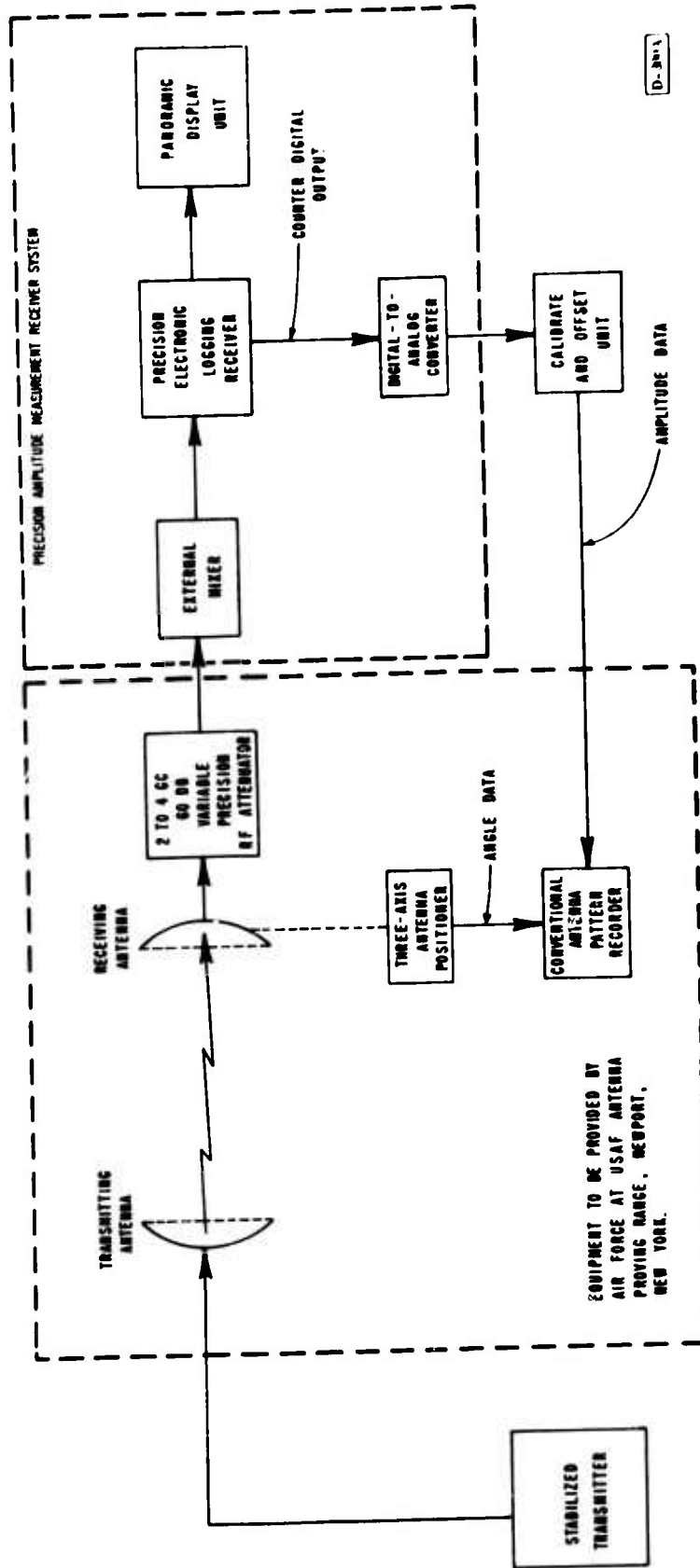

Figure 4
Phase II Equipment Incorporated Into RADC Antenna Pattern Measurement System

Work accomplished under Phase I was reported in the following reports:

Investigation of Precision Antenna Pattern Recording and Display Techniques, First Quarterly Report, 1 April 1962 to 30 June 1962, RADC-TDR-62-365.

Investigation of Precision Antenna Pattern Recording and Display Techniques, Second Quarterly Report, 1 July 1962 to 30 September 1962, RADC-TDR-62-560.

Investigation of Precision Antenna Pattern Recording and Display Techniques, Third Quarterly Report, 1 October 1962 to 31 December 1962, RADC-TDR-63-53.

Investigation of Precision Antenna Pattern Recording and Display Techniques, Final Report, 1 April 1962 to 29 March 1962, AD 415-912.

Work under Phase II has been reported in the following reports:

Precision Antenna Pattern Recording Techniques, Phase II, First Quarterly Report, 1 June 1964 to 28 August 1964, RADC-TDR-64-420.

Precision Antenna Pattern Recording Techniques, Phase II, Second Quarterly Report, 31 August 1964 to 6 November 1964, RADC-TR-64-541.

Precision Antenna Pattern Recording Techniques, Phase II, Third Quarterly Report, 9 November 1964 to 29 January 1965, RADC-TR-65-85.

Investigation of Precision Antenna Pattern Recording and Display Techniques, Phase II, Final Report, Volume I, Project 4506, Task 450604, December 1965.

2. TRANSMITTER

2.1 Design Objective

The general technical goals for the RADC precision antenna pattern measurement program are illustrated in Figure 1. Under Phase II of this program, the stabilized transmitter for the frequency range of 2 to 4 GHz was developed in accordance with these advanced objectives for the USAF Antenna Proving Range at Newport, New York.¹ The techniques employed in the equipment furnished under this program are applicable over the frequency range from 0.2 to 12 GHz as required by the RADC program. Additional equipment can be obtained for other frequency bands without an extensive development program. Techniques for extending the frequency coverage are discussed in paragraph 2.4.

The specific requirements for the stabilized transmitter are summarized in Table 1. In addition, it was required that the system be designed with consideration for the normal antenna-range application and environment and with attention to the ease of operation, alignment, and calibration. The transmitter was designed to meet the technical objectives when operated from an auxiliary motor-generator set in the event commercial power is not available at the transmitter site.

Table 1
Transmitter Design Specifications

Characteristic	Specification	
	Minimum	Objective
Frequency	2-4 GHz	2-4 GHz
Power Output	0.5 watt	1.0 watt
Amplitude Stability	0.01 db/hour	0.002/db/hour
Frequency Stability	1/10 ⁶ /week	1/10 ⁶ /week

2.2 Design Approach

The major design problem for both the transmitter and receiver was to ensure reasonable long-term amplitude stability. It is desirable to eliminate antenna range measurement errors as far as practical, and since the resolution of the

¹Jaeger, Martin, The USAF Antenna Proving Range (Interim Report), Technical Memorandum No. RAL-TM-62-5; November 1962.

measuring system is set by the receiver as 0.01 decibel, the transmitter power stability was specified as 0.002 decibel per hour. To achieve this objective, methods of stabilizing signal sources to a high degree of precision were investigated. Engen^{2,3} has reported on a self-balancing, dc, bolometer bridge with a power stability on the order of a few parts in 10^4 per hour. To achieve this high degree of stabilization, the temperature of the detector element was controlled to approximately $\pm 0.005^\circ\text{C}$ by immersing the detector in a temperature-regulated water bath. Although these results are obtainable under laboratory conditions, and where a 5- to 8-hour warm-up time is practical, it is not reasonable to require very high temperature stabilization for an operational piece of field equipment.

The temperature susceptibility of a bolometer or thermistor detector can be reduced by temperature compensating the RF detector. Power detectors are commercially available which contain two identical thermistors, one sensitive to absorbed RF power, and one sensitive to ambient temperature only. With this configuration, the sensitivity of the detector to ambient temperature variations can be reduced to about one percent of that of an uncompensated detector. Private communications indicate that a temperature unbalance of 2 to 4 mw per degree centigrade can be expected for a detector with an RF operating range of 10 mw. In this case, the detector stability should be approximately 0.002 decibel per degree centigrade provided proper care is given to the heat transfer through the RF cable and support structure. Other factors, such as thermistor bias supply stability and design of the audio bridge circuit, would have to be carefully considered in order not to introduce appreciable errors.

The power detector selected for the amplitude-stabilization loop is a Model N420 manufactured by General Microwave Corporation. This unit contains a thermoelectric detector⁴ consisting of a thin film metallic load that absorbs the incident RF power. Bismuth and antimony films are vacuum-deposited on a thin

² Engen, Glen F., "A Self-Balancing Direct-Current Bridge for Accurate Bolometer Power Measurements," Manual of Research of the National Bureau of Standards, Vol. 59, No. 2, August 1957.

³ Engen, Glen F., "Amplitude Stabilization of a Microwave Signal Source," IRE Transactions on Microwave Theory and Techniques, MTT-6, No. 2, pp. 202-206; April 1958.

⁴ "Thin-Film Calorimeter Measures 0.3 Microwatt Full Scale," Microwaves, March 1964; pp. 114-115.

Mylar substrate in a configuration that produces a number of thermoelectric junctions. Incident RF power increases the temperature of these junctions, causing an emf to be generated which is proportional to the power absorbed. A reference junction is maintained in thermal contact with the detector housing. The manufacturer states that the temperature stability of the detector without compensation by external circuitry is approximately one percent (or 0.004 decibel) per degree centigrade.

In order to further reduce detector errors in the operating system, the output directional coupler, power detector, and amplifier input circuitry were mounted in a shielded, insulated, and temperature-controlled chamber. The design of the chamber and regulator, and the stated characteristics of the detector appear sufficient to provide long-term stability of the signal source of 0.002 decibel. The stability of the signal source is rated at 0.01 decibel per hour, however, because of the impracticality of measuring and proving greater accuracy (see Chapter 4).

Transmitter frequency stability of 1 part in 10^6 was specified in order to reduce measurement errors caused by the frequency-dependence of received signal level on antenna characteristics, transmission lines, antenna range characteristics, etc. This degree of stabilization was readily achieved by employing conventional phase-lock techniques and a commercial phase-lock synchronizer. A brief discussion of the principle of operation is given in paragraph 2.3.1.

2.3 General Description

The stabilized signal source is composed of five units, all of which are mounted in an Optima equipment rack as shown in Figure 2. The basic unit, designated as "signal source, 2-4 GHz," is a modified Scientific-Atlanta Series 2160 RF Oscillator Unit with provisions for phase locking and amplitude leveling. The temperature-stabilized power detector unit contains the reference RF power detector and leveler amplifier employed for maintaining the output power constant. The temperature of the power detector is held constant by a temperature regulator in order to reduce power variations caused by changes in ambient temperature. A Model KS-123 Klystron Synchronizer, manufactured by Frequency Engineering Laboratories, is employed to phase-lock the signal source to a crystal reference. A Model 454AR Thermoelectric Power Meter, manufactured by General Microwave Corporation, is provided to monitor RF output power. Connections to the power meter are made through the RF connector panel.

Detailed information concerning operating procedures and theory of operation for the transmitter is given in the instruction manuals for the signal source.

2.3.1 Principles of Operation

A block diagram of the stabilized signal source is shown in Figure 5. Microwave power is obtained from a triode oscillator in a mechanically-tuned triaxial cavity covering the frequency range of 2 to 4 GHz. The frequency of the oscillator is varied electronically to phase lock the source to an external reference by varying the voltage applied to two varactor diodes, which form a coupling loop in the oscillator cavity. Voltage applied to the varactors varies the reactance of the coupling loop and therefore affects the oscillator frequency. The voltage applied to the varactors is controlled by the phase-lock synchronizer to reduce frequency modulation of the signal source.

The microwave oscillator is mechanically tuned by a servo system to keep the output of the phase-lock synchronizer balanced. Input to the servo system is obtained from a chopper that compares the output of the phase-lock synchronizer with the dc varactor bias voltage. The error signal from the chopper is fed to a servo amplifier connected to the tuning motor; the tuning motor causes the oscillator frequency to change in the direction to reduce the dc output of the phase-lock synchronizer to zero. Thus the oscillator is retuned to automatically compensate for drift in oscillator frequency, and frequency modulation of the source is suppressed by the electronic phase loop employing the varactor diodes. The tracking servo is disabled while the oscillator is being set manually to the desired frequency; it is disabled automatically if the system drops out of phase lock.

Amplitude stabilization of the signal source is achieved by varying the plate voltage of the triode oscillator to maintain the output power constant. Two feedback loops are employed: (1) a dc feedback loop containing the temperature-stabilized power detector unit, and (2) a high-frequency loop employing a crystal detector and wide-band leveler amplifier. The dc loop holds the average output power constant. The temperature environment of the RF detector in the temperature-stabilized power detector unit is regulated to reduce errors caused by changes in ambient temperature. Because the response time of the RF power detector is approximately one second, a high-frequency loop employing a crystal detector is necessary to stabilize the system and to reduce high-frequency noise-modulation components.

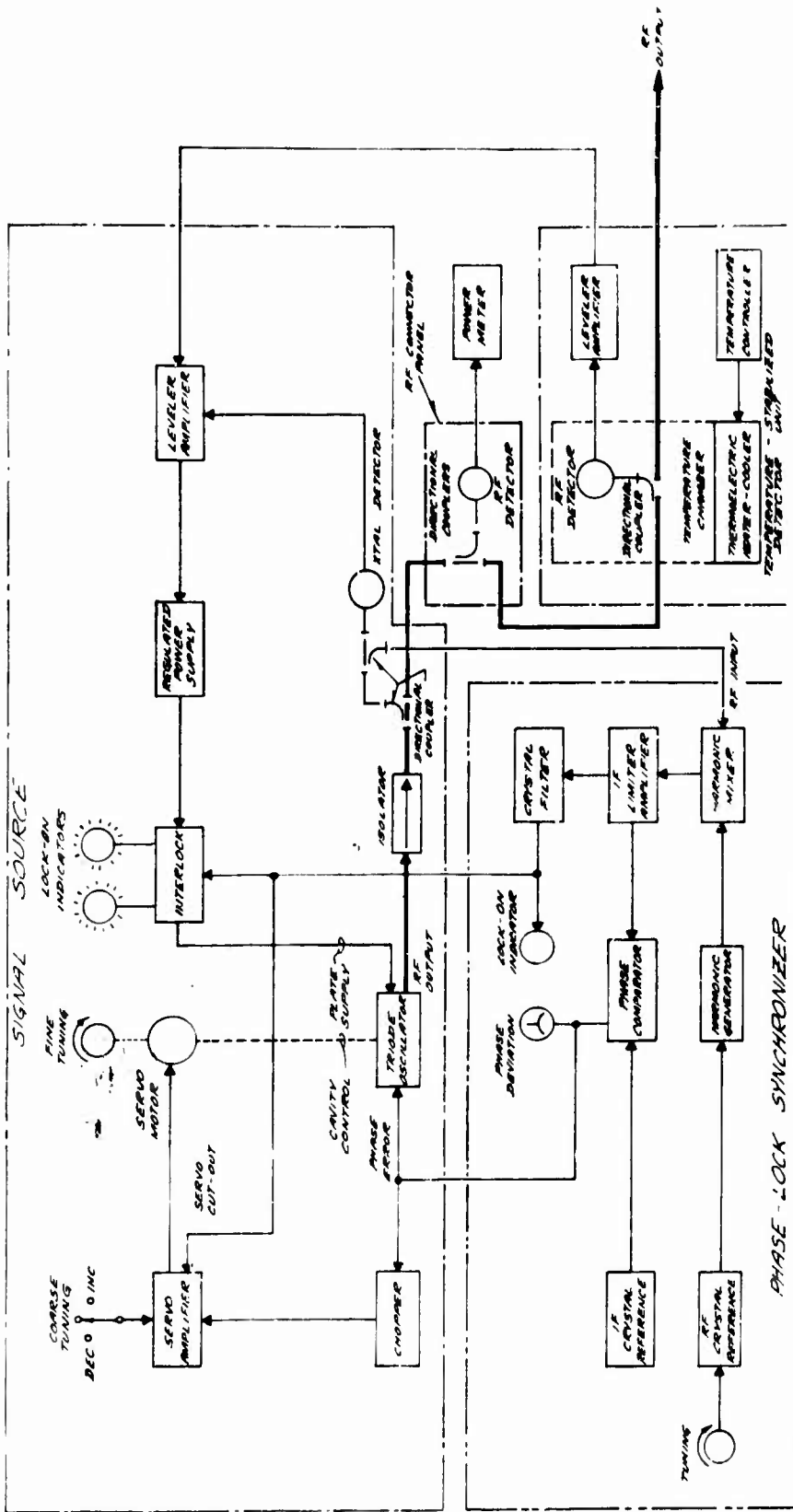

Figure 5
Block Diagram of Stabilized Signal Source

The temperature-stabilized power detector unit contains the RF detector and directional coupler in a thermally insulated compartment. The inside compartment is maintained at normal room temperature by thermoelectric cooling modules, which operate on the Peltier effect. By reversing the polarity of voltage applied to the thermoelectric modules, the direction of heat flow is reversed; thus the modules can either heat or cool the insulated compartment. A proportional-control regulator maintains the temperature within approximately 0.5°C of the set point for ambient temperature changes of $\pm 20^{\circ}\text{C}$ from normal room temperature. The set point is usually set equal to the ambient temperature at the time the equipment is turned on, in order to reduce the time required to reach thermal balance.

The output of the phase-lock synchronizer is connected to the varactor diodes and tracking servo previously described. The RF input to the synchronizer is obtained from a directional coupler on the output of the signal source. The input signal is heterodyned against a harmonic of the RF crystal reference to generate an intermediate frequency, which is amplified in a limiter amplifier to a level suitable for phase comparison with the IF crystal reference. When the IF and IF-reference signals are in phase quadrature, zero output voltage is developed by the comparator. When the phase differs from 90 degrees, voltage is developed and applied as an error signal to the varactors in the oscillator cavity.

The RF reference for the phase-control loop is obtained from a crystal oscillator that is switched to any one of eight quartz crystals operating at approximately 8 to 9 MHz. To achieve continuous tuning of the transmitter, the crystal oscillator is pulled slightly in frequency. The output of the crystal oscillator is multiplied to obtain the RF reference for the transmitter. The front-panel tuning control pulls the crystal frequency and automatically switches between crystals.

In operation, the signal source is first tuned to the desired frequency as indicated by the tuning dial, or by an external wave meter, and the amplitude leveler is adjusted. The synchronizer is then adjusted to phase-lock the signal source with the tracking servo disabled. Finally, the tracking servo is turned on to keep the phase-lock synchronizer balanced as the oscillator warms up. Alarm circuits may be energized to indicate if the system drops out of lock range of the phase- or amplitude-stabilization loop.

2.3.2 Specifications

Frequency Range	2.0 to 4.0 GHz
Power Output	0.5w into 50-ohm load (Figure 9)
Source Impedance	50 ohms
RF Output Connector	Type N, female
Stability	
Amplitude	0.01 db/hr
Frequency	1 part per 100 million per second 1 part per million per day at constant ambient temperature 2 parts per million per degree centigrade ambient temperature
Frequency Tuning	Continuous
Tuning Dial Accuracy	±0.5%
Temperature Regulator Control Range	Set point adjustable from 17°C to 38°C
Temperature Regulator Cooling or Heating Capacity	±20°C from set point
Alarm Interlock Outputs	Latched relay output if either phase alarm or level alarm circuit is tripped.
Power Requirements	115v ±10%, 50/60 Hz, 350w
Overall Dimensions	
Height	67-3/4 in
Width	22 in
Depth	46-1/4 in (includes 18-inch writing shelf)

2.4 Extension of Frequency Range

The contract for the development of the transmitter specified that the techniques employed for the 2- to 4-GHz frequency range be applicable to the 0.2- to 12-GHz range so that additional equipment can be obtained at a minimum development cost. The following paragraphs describe ways by which the frequency of the present system can be extended. Maximum benefit of the existing 2- to 4-GHz

system is obtained by adding to or duplicating items already developed. Many of the components are standard items in the Scientific-Atlanta Signal-Source line.

Phase locking in the 0.2- to 12-GHz range can be accomplished with the existing phase-lock synchronizer, except as noted for the 0.2- to 1-GHz range. The power detector and leveler amplifier contained in the temperature-stabilized detector unit can be used, since the frequency range of the detector is 10 MHz to 12.4 GHz. Directional couplers for the particular band will have to be added to feed the power detector and power monitor. It is suggested that for convenience the directional coupler feeding the leveler detector be mounted external to the temperature-controlled chamber. Experience with the 2- to 4-GHz system indicates sufficient stability can be expected without mounting the coupler inside the chamber, provided the coupler is in a reasonably constant ambient environment.

2.4.1 Frequency Range 0.2 to 1.0 GHz

A number of RF sources will furnish 1 watt in the 0.2- to 1.0-GHz frequency range. These include solid-state, vacuum-tube, and voltage-tuned magnetron devices. A major factor to be considered in selecting the type of signal source is the ease with which the source can be phase-locked and leveled.

To phase-lock the signal source, the oscillator must be voltage-tunable over a range great enough to allow for compensation of incidental FM and long-term drift. Some of the oscillators, such as voltage-tuned magnetrons, naturally have this capability. Others, such as vacuum-tube oscillators, can be adapted to tune over a small range by adding a varactor across the tuning element.

The output of the phase synchronizer will feed a high-input-impedance device such as a varactor. If current must be furnished to the control element, an amplifier will be required. The existing phase synchronizer will operate, but not tune, continuously over the frequency range of 0.2 to 1.0 GHz. For continuous tuning, a stable, external RF reference is required.

Signal source leveling can be accomplished by feeding a control voltage to an internal, dc-coupled modulation amplifier or to an external diode modulator. The output of the leveler amplifier in the temperature-stabilized detector unit may be used as the control voltage. A high-frequency feedback loop is required to stabilize the system. Additional directional couplers for the UHF range are required to feed the power monitor and high- and low-frequency detectors.

2.4.2 Frequency Range 1 to 2 GHz

This frequency range can be covered by adding to the system a Scientific-Atlanta Signal Source identical with the 2- to 4-GHz source, except with a 1- to 2-GHz oscillator. The oscillators for both frequency ranges are of similar construction; both contain a microwave triode in a triaxial cavity with varactors in a coupling loop for tuning the oscillator over a small frequency range. The major difference between the units is that the cavities are tuned to $1/4$ - and $3/4$ -wavelength for the low- and high-frequency octave bands.

Phase-locking and leveling can be accomplished in the same manner as for 2 to 4 GHz. The signal source would contain the high-frequency amplitude-stabilization loop and the necessary circuitry for use with the existing phase-lock synchronizer.

2.4.3 Frequency Range 4 to 12 GHz

Power for this frequency range can be obtained by adding harmonic generators and TWT amplifiers to the existing system. The 2- to 4-GHz signal source would be employed to furnish fundamental power. The signal source would feed an octave-bandwidth doubler, filter, and 4- to 8-GHz TWT amplifier. For the 8- to 12-GHz range, the signal source would feed a tripler, filter, and TWT amplifier. Scientific-Atlanta has developed and packaged in a single unit multipliers, filters, TWT amplifiers, and band-switching circuitry for the 4- to 12-GHz range. The unit will deliver 1 watt output when operated with a Scientific-Atlanta 2- to 4-GHz Signal Source.

One advantage of employing multipliers to generate the higher frequencies is that no additional circuitry is required for phase-locking the transmitter. Furthermore, the existing high-frequency amplitude-stabilization loop can be used, assuming the noise generated by the harmonic multipliers is not excessive. The existing low-frequency leveler detector and amplifier can be used to close the loop around the TWT amplifier to reduce output-power drifts caused by changes in multiplier conversion loss and amplifier gain.

BLANK PAGE

3. PRECISION AMPLITUDE MEASUREMENT RECEIVER SYSTEM

3.1 Design Objectives

The general technical goals for the RADC precision antenna pattern measurement program are illustrated in Figure 1. Under Phase II of this program, the precision amplitude measurement receiver system was developed in accordance with these advanced objectives for the USAF Antenna Proving Range at Newport, New York.

The specific design specifications under which the receiver system was contracted are summarized in Table 2.

Table 2
Receiver System Design Specifications

Characteristic	Specification	
	Minimum	Objective
Frequency Coverage	2-4 GHz	0.2-12 GHz
Dynamic Range	50 db	60 db
Sampling Rate	1000 Hz	1000 Hz
Resolution	0.01 db	0.01 db
Amplitude Accuracy		
0 to -15 db	0.05 db	
-15 to -30 db	0.10 db	
-30 to -50 db	0.25 db	
0 to -10 db		0.02 db
-10 to -40 db		0.10 db
-40 to -60 db		0.25 db
Receiver Sensitivity	-80 dbm	-90 dbm
Receiver Noise Figure	15 db	10 db

3.2 Design Approach

In Scientific-Atlanta Technical Proposal SP-146, a new logarithmic-conversion technique operating at IF frequencies was described as a solution to the high-speed, high-accuracy, decibel-readout requirements of the RADC program. This system appeared capable of overcoming the inertia problem of electro-mechanical logarithmic-conversion systems and the inaccuracy problem of

conventional conversion circuits such as logarithmic IF amplifiers. Further investigations during Phase I of the RADC program confirmed that the feasibility of obtaining the data rate and accuracy objectives of the RADC program appeared to depend on the capabilities of the new logarithmic-conversion system.

The basic principle of this system is presented in Figure 6. If an LCR circuit is pulsed at its resonant frequency, $\omega_0 = 1 / \sqrt{LC}$, to a peak voltage V_0 and is allowed to ring down beginning at t_0 , the envelope of the voltage at t_1 is

$$V_1 = V_0 \exp \frac{-\omega_0 (t_1 - t_0)}{2Q} \quad (1)$$

where

$$Q = \frac{\omega_0 L}{R} .$$

The power of V_1 relative to V_0 expressed in decibels is

$$P_{db} = 20 \log \frac{V_1}{V_0} = K(t_1 - t_0) \quad (2)$$

where

$$K = -10 \frac{\omega_0 \log e}{Q} .$$

Thus, time $(t_1 - t_0)$ is linearly proportional to the logarithm of the ratio V_1/V_0 . Coincidence is established between the amplitude of the envelope of the signal and the envelope of the exponentially decaying reference voltage at t_1 . The time interval $(t_1 - t_0)$ is a measure of the signal level in decibels with respect to a signal V_0 . The time interval can be measured by means of a digital counter.

The constant K can be chosen to make a time interval of 300 microseconds represent 60.00 decibels, as is the case in the receiving system reported herein. For a clock frequency of 20 megacycles, a count of 6000 represents a level of 60.00 decibels below a reference level of 0 decibel, which is represented by a count of 0000.

The LCR circuit is actually a re-entrant cavity resonant at the intermediate frequency. For an IF of 65 MHz, the loaded Q of the cavity must be 8875 for a 60-decibel exponential decay in 300 microseconds. For the system developed,

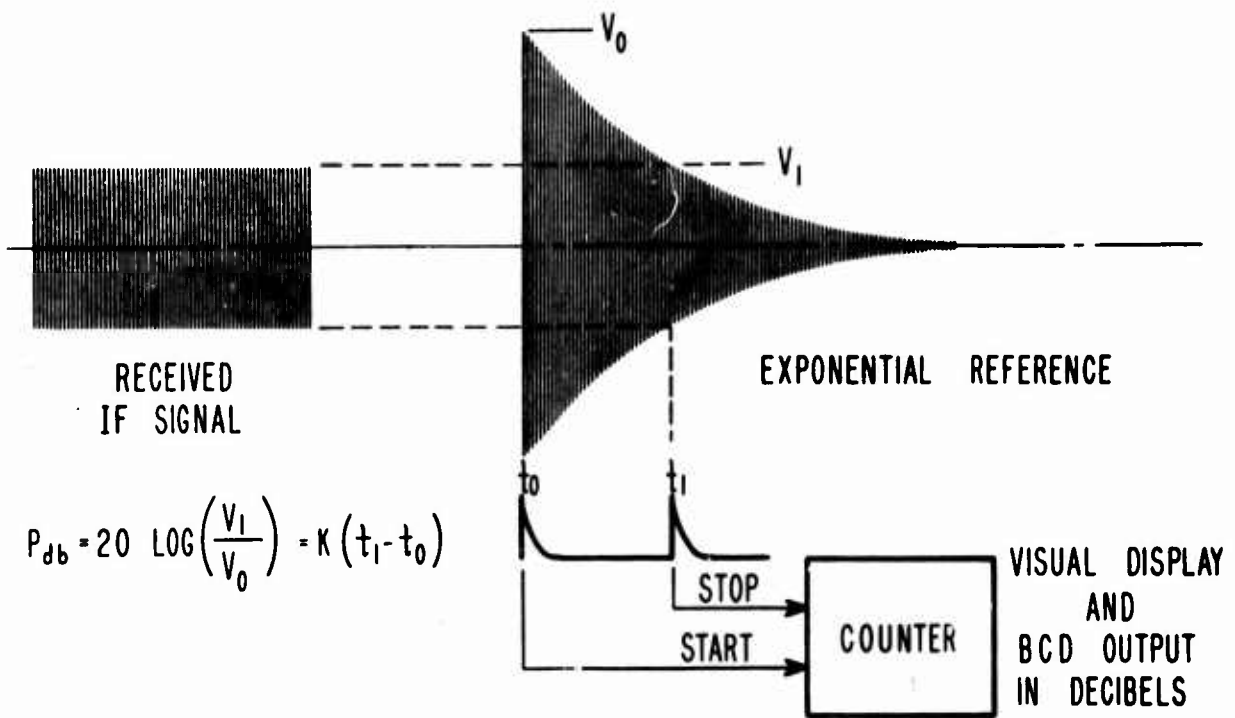

D 987

Figure 6
Principle of Digital Logarithmic Conversion

the outside dimensions of the cavity, including support structure, are 22 by 57 inches.

During the previous study contract, the most promising method of implementation of the above principle was selected for further study to determine overall system feasibility. The method selected provides for time-sharing of a common IF amplifier by the exponentially decaying reference and the signal. The following advantages are derived from this technique:

- (a) Virtual elimination of video-detector errors, since the AGC action of the system maintains the signal amplitude at the detector approximately constant over a wide dynamic range of measurement.
- (b) Achievement of the same accuracy of time-interval measurement over the complete dynamic range, since the slope of the exponential reference at the coincidence level is constant for a constant signal level out of the video detector.
- (c) Direct high-speed conversion of power ratios to decibels in analog or digital form.

Results from the previous study and experimental work demonstrated the feasibility of the method above as reported in the final report of Phase I. These results and application of existing receiver techniques essentially set the basic design approach for the receiver system furnished under this contract. The major design problem was to ensure reasonable long-term amplitude stability in all subunits ahead of the time-sharing common IF amplifier.

3.3 General Description

The precision amplitude measurement receiver system is a superheterodyne receiving system for precision automatic logarithmic measurement of relative input RF levels. This high-resolution system has exceptional linearity over a wide dynamic range and provides direct high-speed decibel data readout in digital and analog form. The system allows remote high-frequency operation of external mixers, through the use of a single coaxial cable, without a loss in system sensitivity. Through harmonic mixing and up-conversion techniques, a wide RF range is covered without additional plug-in units.

The receiver system is contained in a console, as shown in Figure 3. The 65-MHz cavity is mounted under the desk top at the rear of the console. The cabinets, which are removable to facilitate movement or placement of the system, are resting on a cabinet base mounted on the console desk top.

Detailed information concerning operating procedures and theory of operation for the receiver system is given in the instruction manuals for the system.

3.3.1 Principles of Operation

A block diagram of the system is shown in Figure 7.

The broad tuning range of the receiver is achieved by the use of two separate RF systems. A first local oscillator, used with both RF systems, is a precision, tunable triode oscillator. This oscillator can be continuously tuned over a frequency range of 2.0 to 4.0 GHz with a mean output of one watt.

From 1.95 to 12 GHz the 2.0 to 4.0 GHz oscillator output is fed through an isolator and adjustable attenuator to the local-oscillator arm of a frequency-selective tee. The tee couples the local-oscillator signal through a coaxial cable to an external crystal mixer. Here, fundamental or harmonic mixing takes place and the resulting 65-MHz IF signal is conducted back through the same coaxial cable and frequency-selective tee to a 65-MHz IF preamplifier. The use of a single coaxial cable between the external mixer and the receiver is important in an antenna pattern range receiver because it permits use of single-channel, coaxial-line rotary joints in the antenna positioner. Although the coaxial cable connecting the receiver and the mixer attenuates the local-oscillator signal, its effect on the receiver sensitivity is negligible because the cable attenuation at the intermediate frequency is small.

The low-frequency RF system employs double conversion in the frequency range from 20 MHz to 1.95 GHz using the triode oscillator as a tunable first local oscillator. The low-frequency input RF signal is connected by 50-ohm coaxial cable to the internal first mixer through the low-frequency input connector. Signals from 20 MHz to 1.95 GHz fed into the first mixer are converted to a 2145-MHz first-IF signal by tuning the local oscillator to a frequency 2145 MHz higher than the received signal. A 2145-MHz, four-section cavity and a low-pass filter, located in the second-mixer unit, provide the first-IF selectivity. The crystal-controlled 2080-MHz second local-oscillator signal is fed into a second mixer for conversion of the 2145-MHz first-IF signal into a 65-MHz second-IF signal, which is fed to the IF preamplifier.

Automatic tracking of the first local-oscillator to maintain a constant 65-MHz intermediate frequency is achieved by an automatic phase control (APC) system. A portion of the 65-MHz IF signal is coupled from the IF preamplifier and amplified in an IF limiter amplifier to a level suitable for phase comparison in the phase detector with a reference signal from the 65-MHz crystal oscillator. For a departure of the input and reference signals from phase quadrature, the phase detector produces a dc error voltage which is connected to a varactor mounted in the local-oscillator cavity so that its output frequency is corrected to maintain a constant 65-MHz intermediate frequency. Under lock conditions, RF signal or local-oscillator drifts can cause only phase shifts, not frequency shifts, in the 65-MHz intermediate-frequency signal. In addition, the APC error voltage is coupled through a 60-Hz chopper to a servomotor amplifier for correction of long-term frequency drifts by motor tuning the local oscillator.

The IF preamplifier provides an output for the panoramic display unit. The CRT display of this unit facilitates receiver tuning and provides a visual check on APC operation and RF signal purity.

A logarithmic time analog of the relative amplitude of the received signal is obtained by memorizing and comparing the received signal level with an exponentially-decaying reference signal as explained in paragraph 3.2. To accomplish this, the time-shared IF amplifier is switched between an output of the IF preamplifier and the 65-MHz exponential reference. The exponential reference is generated by gating the gate reference oscillator on with a 360 microsecond signal, so that the 65-MHz cavity is charged to a constant energy level and allowed to decay. The loaded Q of the cavity is adjusted so that the reference signal decays 60 decibels in 300 microseconds.

The signal and the exponential reference are alternately amplified by the 65-MHz IF amplifier. The detected envelope of the composite amplified signal is fed to the automatic gain control (AGC) and comparator circuits. Both circuits are controlled by timing signals triggered by the stop pulse from the last measurement. First, the AGC amplifier is gated on to control the IF amplifier gain for a constant video signal output. Next, the comparator is gated on to store the amplitude of the video signal as a reference level for the comparator. At the next sampling-command trigger internal or external, the AGC amplifier is gated off to hold the gain of the IF amplifier constant until a stop pulse is generated. After 100 microseconds the comparator storage circuit is disconnected to memorize the signal level. When the amplitude of the exponential-reference

envelope decays to the memorized amplitude of the signal, a stop pulse is generated by the comparator.

The start pulse, which is generated at the start of the decay of the reference signal, and the stop pulse are connected to the time analog-to-digital converter. The converter counts the number of cycles of a 20-MHz internal clock which occur between start and stop pulses. This count provides a linear measurement of the level of the received signal in decibels below a reference-signal level which produces a visual and rear BCD digital output of 00.00 decibel. Each period of the 20-MHz clock (50 nanoseconds) corresponds to an amplitude change of 0.01 decibel.

A digital-to-analog converter is incorporated in the system to convert the digitized output of the time analog-to-digital converter to an analog voltage output for operating a conventional antenna pattern recorder with linear pen response. This converter provides a dc output of 1.0 volt per 10.0 decibel.

A calibrate and offset unit was constructed as an accessory to the receiver to adapt a Scientific-Atlanta Series APR 20 Rectangular Recorder for recording the analog voltage output of the receiver system. With this unit, full scale travel on the recorder may be switched in five ranges from 5 to 60 decibels. A continuously variable voltage added to the analog output of the receiver provides up to 60 decibels suppression for making high-resolution recordings over any portion of the dynamic range of the receiver.

3.3.2 Specifications

Receiver Type	Superheterodyne
Input Signals	CW
Frequency Coverage*	200 MHz to 12 GHz
Tuning	
Coarse	Motor drive
Fine	Manual knob
Tuning Dial	
Function	Linear versus frequency
Accuracy, 20 MHz to 1.95 GHz	±1% of local oscillator frequency
Accuracy, 1.95 GHz to 24 GHz	±1% of received signal

*Useful frequency coverage is not sharply defined. Useful operation extends down to 20 MHz, but with points where very low-level spurious responses can affect APC operation and the accuracy of the system. Useful operation extends above 12 GHz, but with reductions in system dynamic range or accuracy.

APC System	Electronic and servo tracking	
APC IF Dynamic Range (typical)		
Electronic	85 db	
Servo Tracking	75 db	
APC Electronic Action (typical)		
	<u>Harmonic Number</u>	<u>Capture Range</u> <u>Lock Range</u>
	1	±22 kHz ±100 kHz
	2	±34 kHz ±200 kHz
	3	±47 kHz ±300 kHz
Maximum IF Input*	-32 dbm	
IF Preamplifier Gain Range	22 db to 31 db	
IF Bandwidth	350 kHz	
IF Noise Figure (typical)	4 db	
Mixer Conversion Loss (typical)		
20 MHz to 1.95 GHz	-19 db	
1.95 GHz to 4.0 GHz	-7 db	
4.0 GHz to 8.0 GHz	-11 db	
8.0 GHz to 12.0 GHz	-15 db	
Maximum RF Input (typical)**		
20 MHz to 1.95 GHz	-13 dbm	
1.95 GHz to 4.0 GHz	-25 dbm	
4.0 GHz to 8.0 GHz	-21 dbm	
8.0 GHz to 12.0 GHz	-17 dbm	
System Noise Figure (typical)		
20 MHz to 1.95 GHz	22 db	
1.95 GHz to 4.0 GHz	10 db	
4.0 GHz to 8.0 GHz	14 db	
8.0 GHz to 12.0 GHz	18 db	
Visual Readout Display		
Type	4 decades, in-line Nixie	
Decimal Point	Fixed between second and third digits	
Readout Title	DECIBELS	
Rear Digital Output		
Type	4 decades, 4-line BCD	
Logic Levels	Zero: 0 to -0.5v One: -10 ±1v, R _g = 1.5k	

*Maximum IF input level for which the system can be adjusted to give a digital output of 00.00 decibel and provide a system linearity without measurable high-level IF preamplifier nonlinearity.

**Considering typical mixer conversion losses, RF input level for maximum IF input level of -32 dbm. See paragraph 4.2 for discussion of mixer non-linearity.

Converter Function	
Normal	Digital output of single amplitude sample
Average	Average digital output of ten 1-kHz amplitude samples
System Data Rate	
Auto--Normal	1 kHz
Auto--Average	100 Hz
Ext--Normal	1 kHz max
Ext--Average	100 Hz max
Ext Trigger Requirements	
Level and Polarity	-7v into 3.3k
Rise Time	1 μ sec max
Width	5 μ sec min
Amplitude Resolution	0.01 db
Amplitude Accuracy*	\pm 0.01 db plus variable mean error shown in Figure 11 and Figures 13 through 16
Dynamic Range	See Figure 11 and Figures 13 through 16
Error Alarm Indicators	
Phase Lock	Latching panel light (indication of failure to maintain lock conditions)
Crystal Current Leveling	Latching panel light (indication of improper leveling conditions)
Panoramic Display	
Display	CRT
Type Display	Amplitude versus frequency
Sweep Rate	1000 Hz
IF Bandwidth	100 kHz
Display Range	
Narrow	400 kHz
Wide	800 kHz
Digital-to-Analog Converter	
Digital Input	Four decades parallel four-line BCD (1248), not logic
Analog Output	0 to 8.999v for digital input of 0000 to 8999. Zero volts for digital input of 9000 to 9999.

* The accuracy of the system depends on the accuracy of the exponential reference signal, which is limited to the accuracy of the cavity Q adjustment, depending in turn on the accuracy of the 65-MHz reference attenuator.

Conversion Accuracy	
Static	$\pm 0.001\text{v}$ (includes long-term stability, $\pm 10\%$ line variation, and $\pm 15^\circ\text{C}$ about 25°C)
Dynamic	Settles to within 0.01% of final value in $10\ \mu\text{sec}$
Output Impedance	Less than $0.1\ \text{ohm}$
Additional Outputs	
Start Pulse	-5v into $93\ \text{ohms}$
Stop Pulse	-5v into $93\ \text{ohms}$
20-MHz Clock	0.5v square wave into $93\ \text{ohms}$
Print Command	-12v pulse, 1k source
Programmer Interlock	Inhibit: -0.5v , low source impedance Noninhibit: -15v , 2.2k source
Bolometer Output	1000-Hz swept panoramic IF response ($4\ \text{ma}$ bias required)
Power Requirements	$115\text{v} \pm 10\%$, $60\ \text{Hz}$, 500w
Dimensions	$66\ \text{in.}$ wide, $49\ \text{in.}$ high, $36\ \text{in.}$ deep

BLANK PAGE

4. SYSTEM PERFORMANCE

The performance specifications given in sections 2.3.2 and 3.3.2 are the results of an evaluation of data obtained from tests conducted at Scientific-Atlanta and RADC. Because of the exceptional accuracy requirements of the system under test and the large number of variables that can affect precise measurements of this nature, it was not possible to determine the ultimate characteristic of the system with test equipment on hand and in the length of time available. A complete determination of accurate specifications, including environmental dependency, would require the use of environmental facilities and the most accurate measuring equipment and standards available today. Furthermore, a considerable length of time would be required for making the tests and resolving any discrepancies. However, the data obtained showed remarkable stability and accuracy for the transmitter and receiver systems, and indicated that, in general, the objective specifications were met.

4.1 Transmitter

The power output of the signal source can be leveled at 0.5 watt from 2 to 4 GHz as measured at the output connector at the rear of the equipment rack. Figure 8 shows the reading of the internal monitor power meter as a function of frequency for 0.5 watt output. The difference in the monitor power reading and measured output power is due to losses in the RF cabling and components and inherent errors in the power meters.

A typical plot of maximum output power as a function of frequency is given in Figure 9. The maximum output power obtainable depends on the alignment of the signal source and aging of the RF triode, and, therefore, will deviate from the typical curve shown. Figure 9 indicates, however, that approximately 1 watt output can be obtained except at the high end of the band.

The frequency stability of the signal source is determined essentially by the stability of the Frequency Engineering Laboratory Model KS 123 Klystron Synchronizer employed to phase lock the signal source. The short-term stability specified for the signal source, 1 part in 10^8 per second, is the short-term stability specified by the manufacturer of the synchronizer. The long-term stability is dependent on the stability of the RF reference crystal oscillator in the synchronizer. The crystals are not temperature controlled,

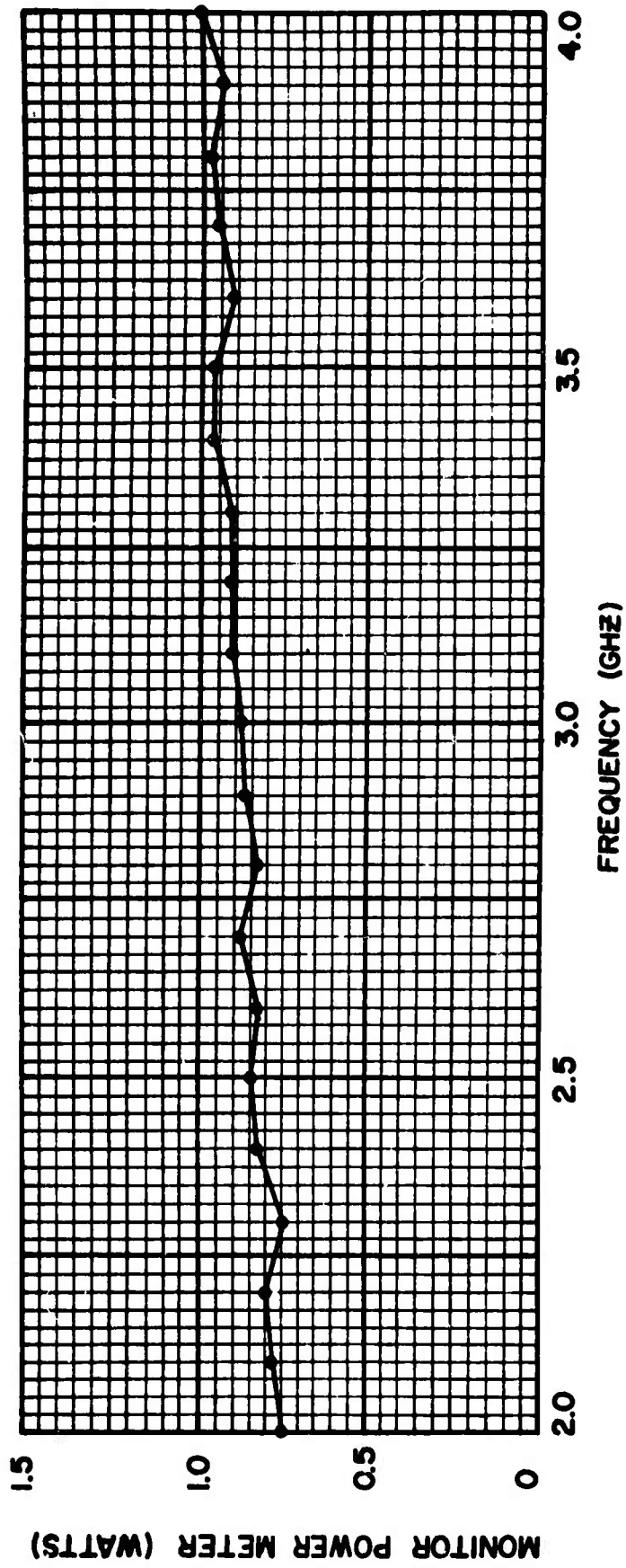

Figure 8
Monitor Power Meter Indication for Rear RF Output of 0.5 Watt

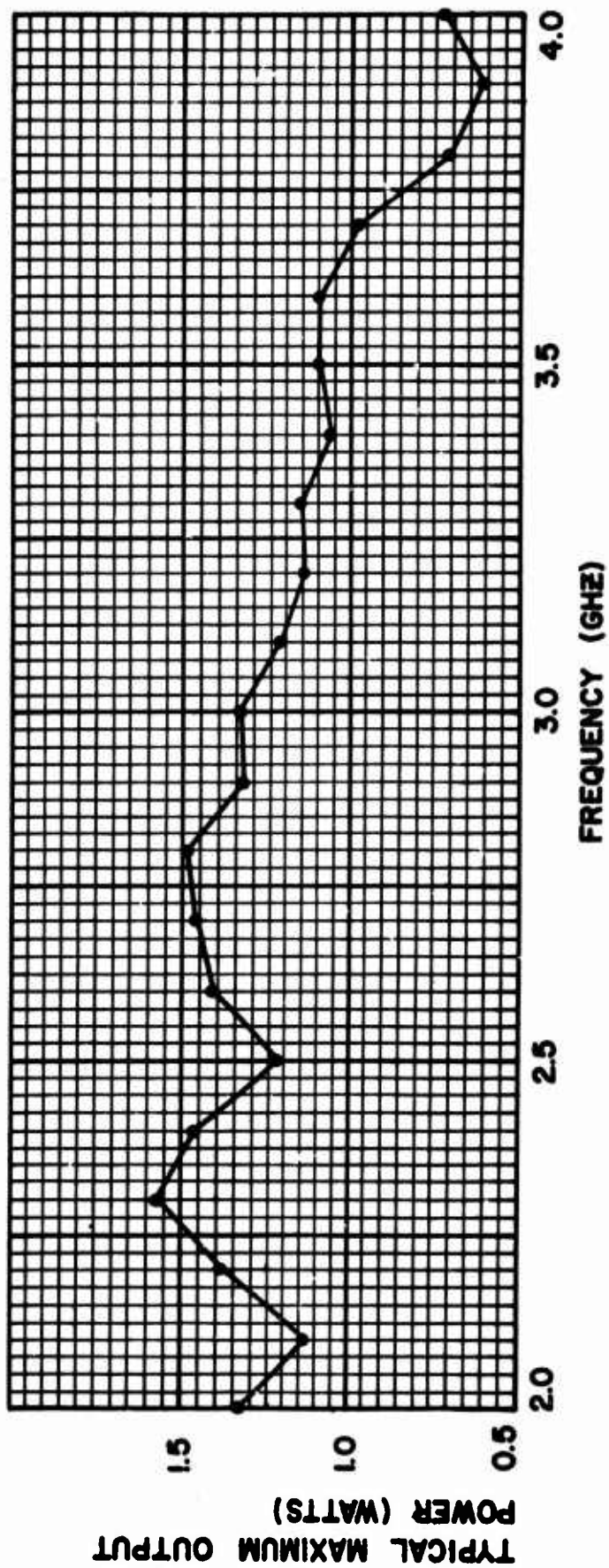

Figure 9
 Typical Maximum Output Power

and, as a result, stability is a function of warm-up time and ambient temperature. Tests indicate a frequency-temperature dependency approaching 2 ppm per degree centigrade.

The long-term power stability of the transmitter was measured by recording output power change employing a General Microwave Corporation Model 454A Power Meter modified for power-offset control. A continuous two-hour record of the power stability measured at a relatively constant laboratory temperature is given in Figure 10. The data contain measurement errors introduced by the offset power meter which are possibly greater than errors in the transmitter leveler itself. Although a quantitative measure of the transmitter stability under varying ambient conditions could not be obtained, the data indicate that the transmitter long-term stability is adequate for the intended application.

Short-term power stability was measured by observing the power output with a broadband video detector. Noise amplitude modulation appears on the output of the signal source primarily because of noise in the high-frequency detector and leveler amplifier. The peak noise modulation appears to be less than approximately 0.002 decibel.

4.2 Receiver

The receiver system tests were concerned primarily with determining the system stability, repeatability, and accuracy or logarithmic conformity. Stability tests were made at the receiver intermediate frequency with the internal 65-MHz crystal oscillator as the source, and at RF from 2 to 4 GHz by employing the stabilized transmitter as the source. For these tests, the receiver visual readout was observed and recorded as a function of time. An attempt was made to isolate the major sources of drift. However, because of the precise nature of the measurements, correlation of the various factors was difficult, if not impossible. Some trends were noted, however, with reasonable agreement with theoretical calculations as discussed later.

The receiver generally exhibited exceptional stability considering the number of factors that can directly affect system stability. It was not uncommon for the receiver output to remain constant within 0.01 or 0.02 decibel over a period of an hour for the tests at the intermediate frequency. Comparable stability was observed for the RF tests. It was difficult, however, to obtain an accurate

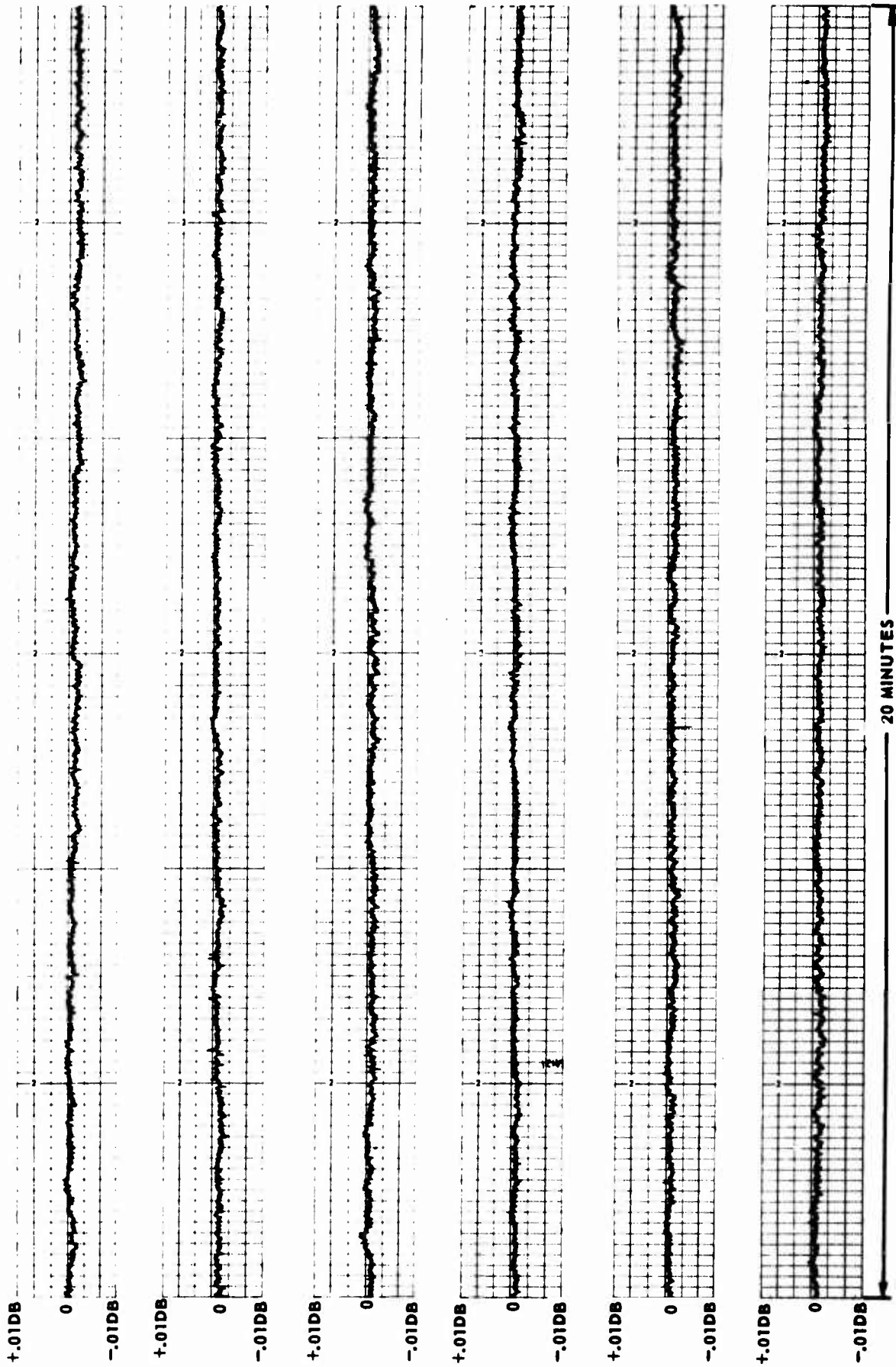

D-981

Figure 10
Transmitter Power Stability Measured Over a Two-Hour Period

stability measurement for the RF tests because of the 0.039 db/°C temperature coefficient of the attenuators connecting the transmitter to the receiver and the temperature sensitivity of the RF mixer.

Data obtained from the stability tests indicate a correlation between changes in the digital readout of the system and ambient temperature. Theoretical calculations were made to determine the effect of temperature changes in the structure of the 65-MHz reference cavity. These calculations indicate that the readout error caused by a change in cavity temperature is caused primarily by the change in resistivity of the cavity walls. The calculated readout error as a function of temperature change is

$$\text{Readout error} \approx 0.01\Delta T(1 - R/10)$$

where R is the readout in decibels, ΔT is the temperature change in degrees centigrade, and the readout error is in decibels. For a signal level that produces zero-decibel readout, the calculated change in readout is approximately 0.01 decibel per degree centigrade change in cavity temperature.

The measured data fit the above readout error approximation exceptionally well considering the accuracy with which the measurement could be made. The relationship was checked by measuring the long-term receiver stability and conformity error and correlating the data with the ambient temperature.

The accuracy, or conformity error, was measured at the receiver intermediate frequency at Scientific-Atlanta and at 3 GHz at RADC. For the measurements at the intermediate frequency, the internal 65-MHz crystal oscillator output was fed through the Weinschel precision reference attenuator to either the IF preamplifier input or the low-frequency RF input to the receiver. For these and other similar tests, the Q of the reference cavity was adjusted to produce readouts of 10.00 and 30.00 decibels for a 20-decibel change of the reference attenuator. The accuracy was then measured by comparing the readout with the change in attenuation of the reference attenuator relative to the zero-decibel value. The rated accuracy of the precision reference attenuator is 0.005 decibel per 10 decibels.

A typical plot of the mean error versus input level to the IF preamplifier is given in Figure 11. The readout was recorded with the system in the average mode of operation, and the mean value of the count fluctuation ascertained by observing the readout display (for low count fluctuation) and by recording and

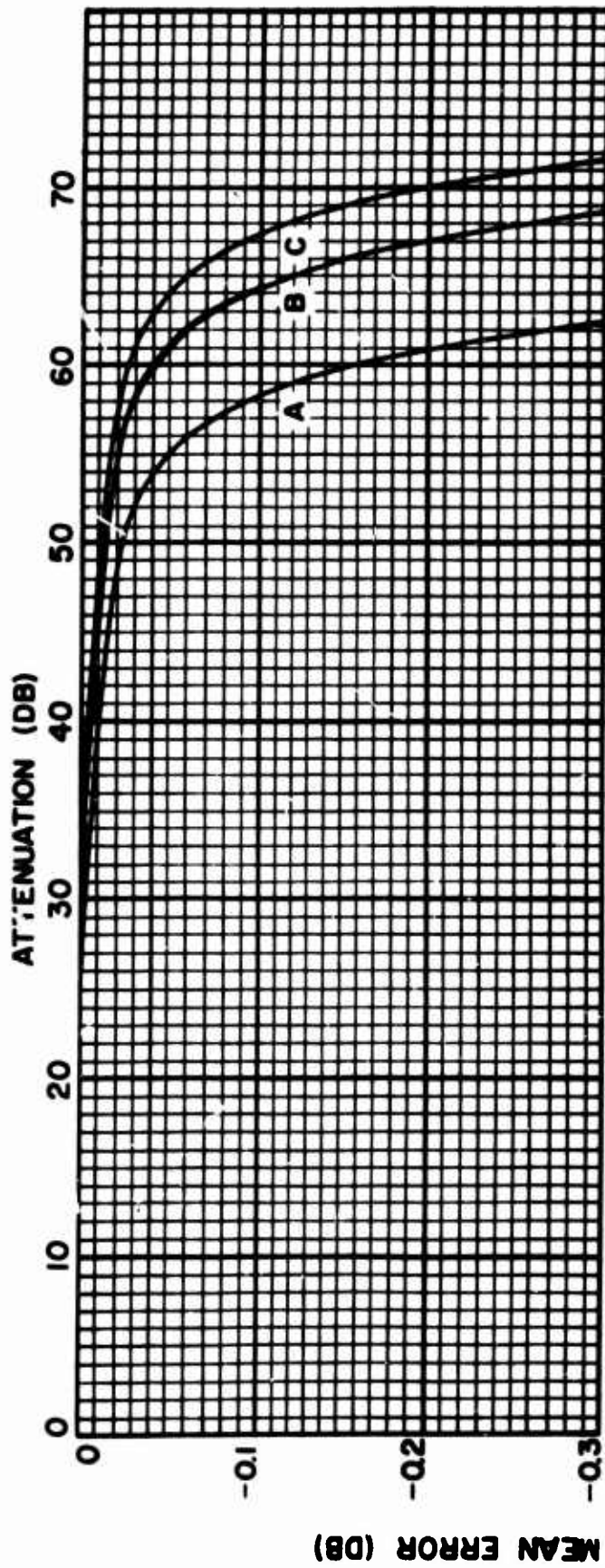

Figure 11
 Typical Mean Error for IF Signal Levels
 Below (A) -41 dbm, (B) -35 dbm, and (C) -32 dbm

averaging single readings with the receiver interrogated at a slow rate. The measurements were performed at several gain levels.

As shown in Figure 11 and all other error curves, amplifier and mixer noise cause an apparent increase in signal level for low signal-to-noise ratios. This effect is caused primarily by rectification of input noise by the video detector. Other factors influence the mean-error curve; it is a function of the relative noise level of the signal and exponential reference in the time-shared IF amplifier, and time constants of the video detector, AGC circuit, and sampler and comparator. These factors were optimized for greatest accuracy at the start of the dynamic range (zero decibel), minimum output noise, and smallest dynamic error for a changing input signal level. To illustrate the effect of system parameters on the mean error curve, the bread-board model constructed during the Phase I study program exhibited a positive error⁵ (instead of a negative error as in Figure 11) for low signal-to-noise ratios. Since the noise output of the common IF amplifier is much greater during the signal interval than during the decay of the exponential reference because of the additional preamplifier gain, the mean error curve could possibly be improved at the expense of increased count fluctuation by injecting noise into the time-shared IF amplifier while the exponential reference is being amplified. However, the additional design effort needed and circuit complexity required to compensate for any IF gain setting, mixer noise, and conversion loss would not be justified.

A plot of the RMS count fluctuation is given in Figure 12 for the normal and average modes of operation. (In the average mode the count displayed is the average of 10 samples taken at a 1000-Hertz rate. Additional filtering in the AGC and sampler circuits when in the average mode further reduces the count fluctuation.) The RMS count fluctuation was measured by measuring the output of the digital-to-analog converter with an ac-coupled, RMS voltmeter. The count fluctuation shown is for a 65-MHz signal input to the IF preamplifier. For an RF input, the count fluctuation will be increased from that shown by the conversion loss and excess noise of the RF mixer.

Typical RF error curves for the frequency range 20 MHz to 12 GHz are shown in Figures 13 through 16. The curve in Figure 13 was plotted from data taken

⁵ Investigation of Precision Antenna Pattern Recording and Display Techniques, Third Quarterly Report, op cit, pp. 31-33.

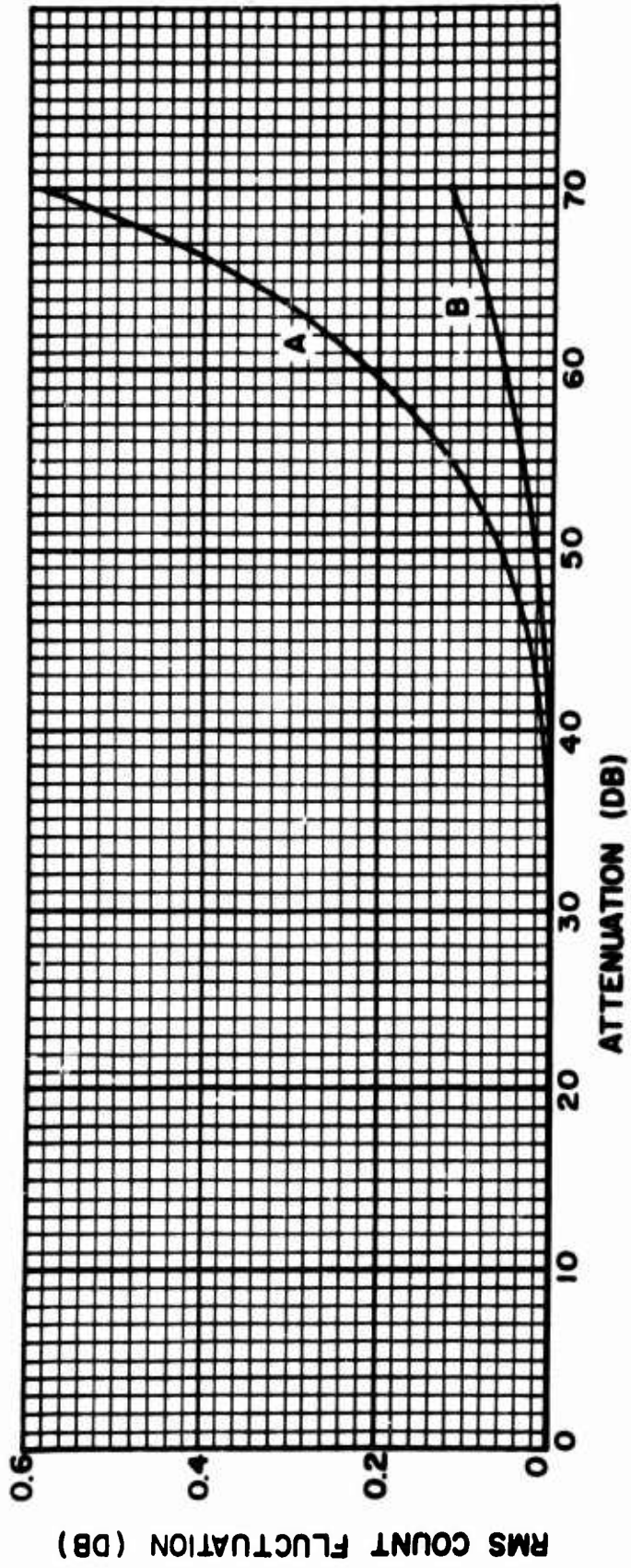

Figure 12
 Typical RMS Count Fluctuation for IF Signal Levels Below -35 dbm
 A = Normal Mode; B = Average Mode.

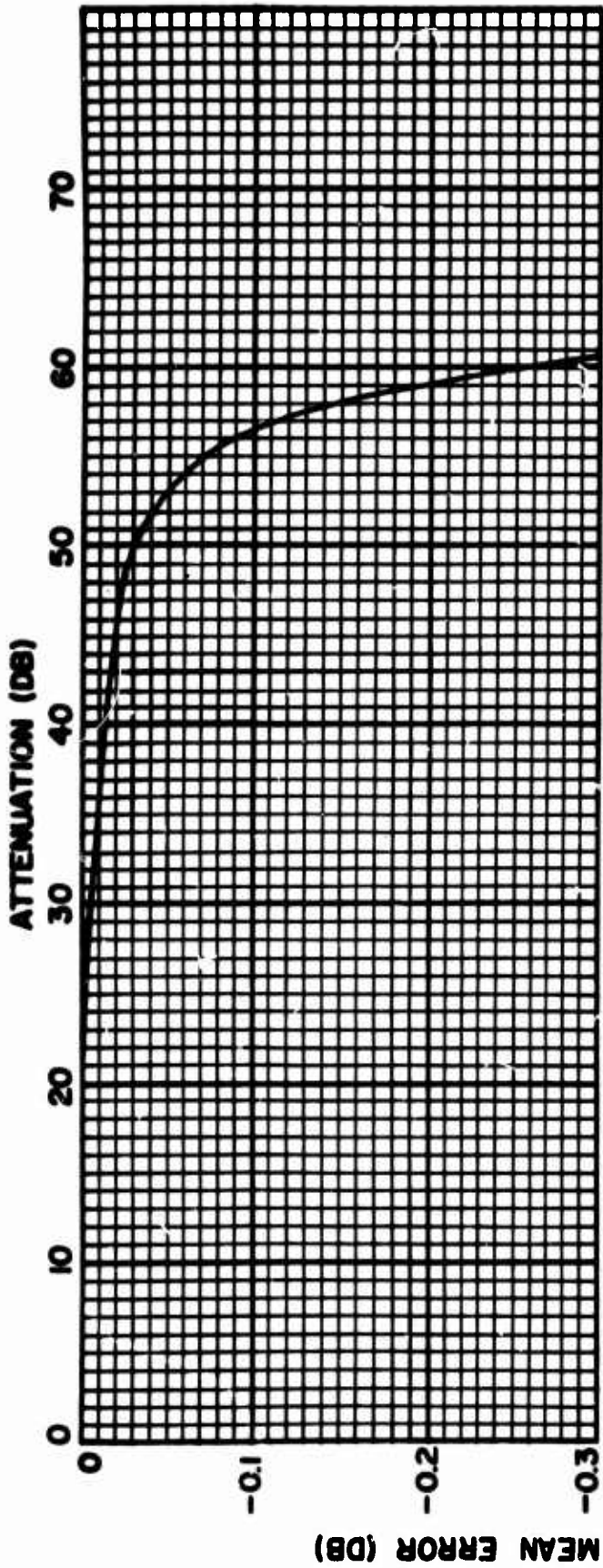

Figure 13
 Typical Mean Error for 20 MHz to 1.95 GHz Signal Levels Below -22 dbm

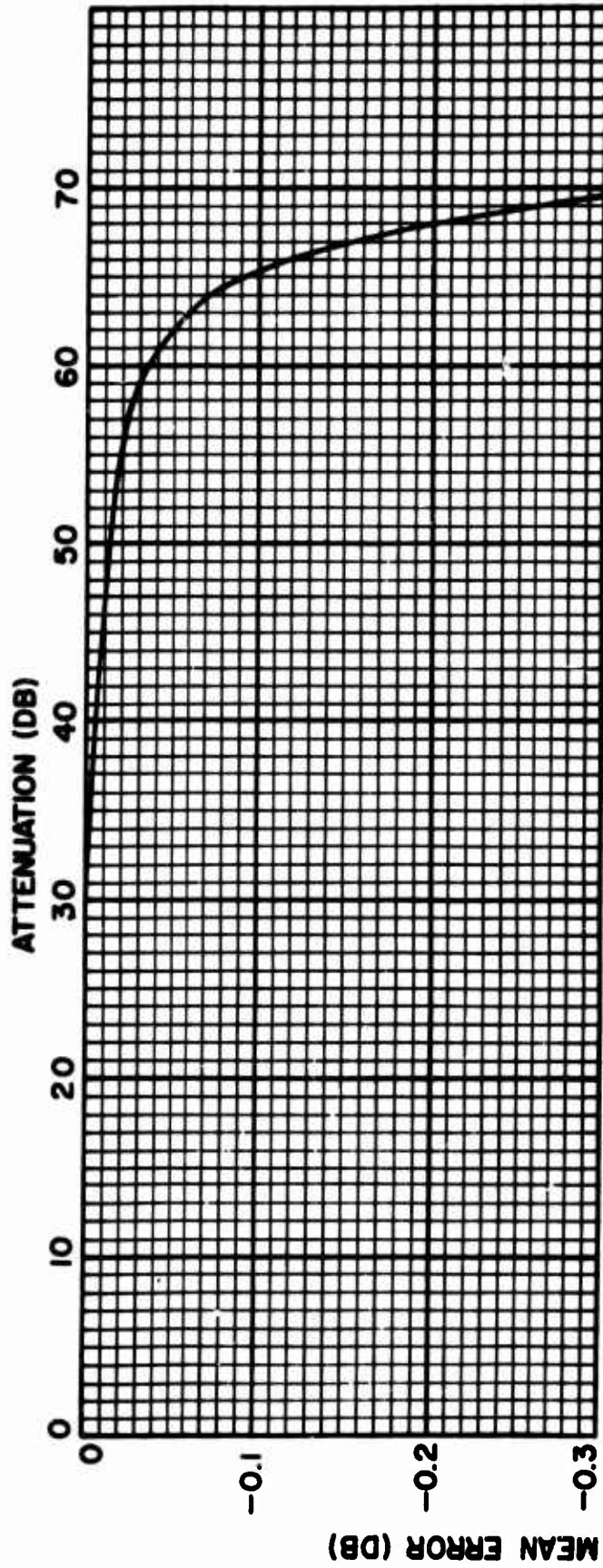

Figure 14
 Typical Mean Error for 1.95 GHz to 4.0 GHz Signal Levels Below -25 dbm

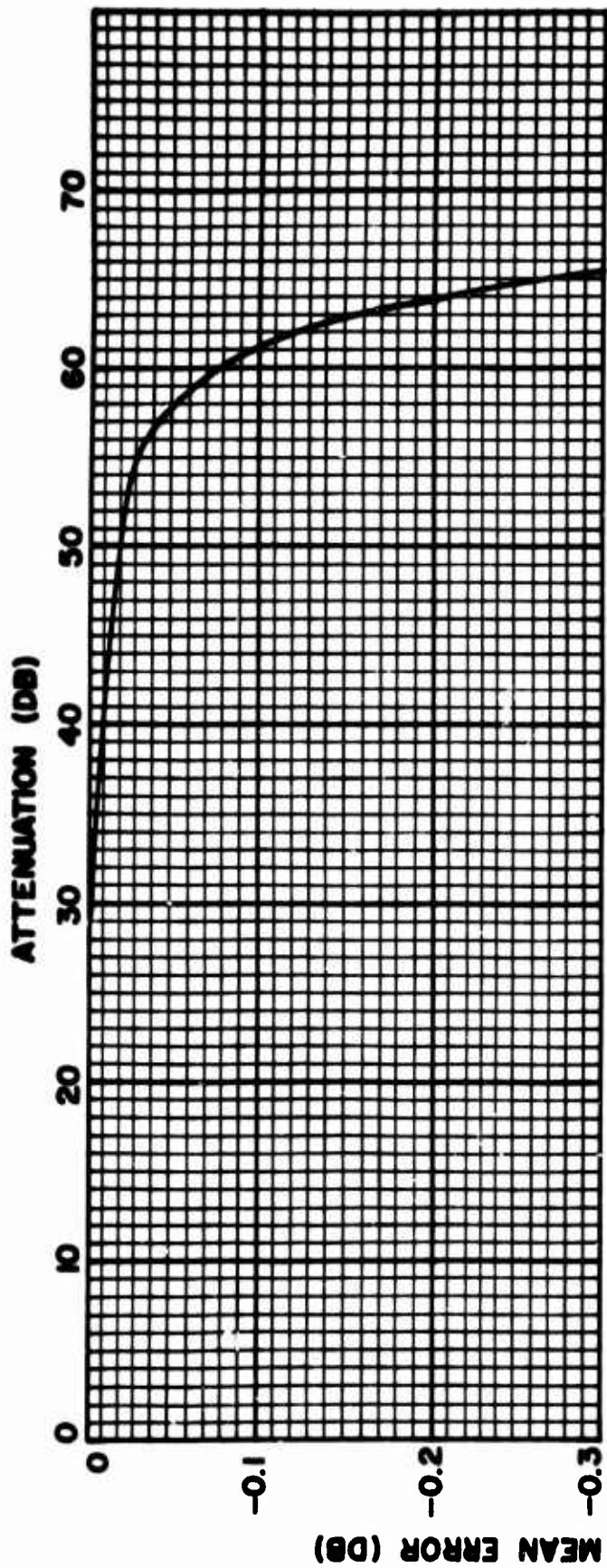

Figure 15
 Typical Mean Error for 4.0 GHz to 8.0 GHz Signal Levels Below -25 dbm

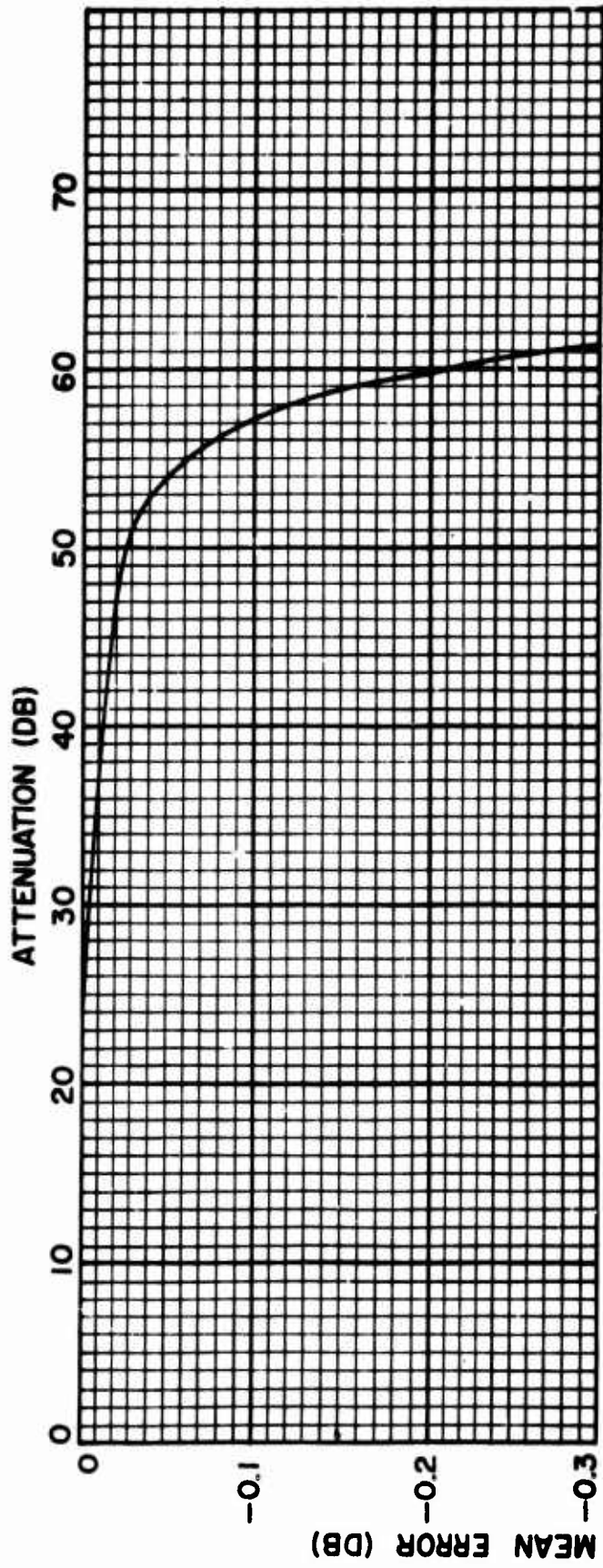

Figure 16
 Typical Mean Error for 8.0 GHz to 12.0 GHz Signal Levels Below -25 dbm

using the internal 65-MHz crystal oscillator as the signal source and the Weinschel 65-MHz reference attenuator to set the signal level. The receiver readout was compared with reference attenuator readings to obtain the error curve.

Data were taken at RADC at 3.0 GHz by comparing the readout with readings obtained with a Weinschel Model 2151 Power Ratio Measuring System (Model VM-3 Receiver, Model HO-1 Harmonic Mixer-Oscillator, and Model HO-A Mixer) as the inputs to the two systems were varied by a common attenuator. Data from this test indicated that with the cavity Q of the 65-MHz reference oscillator adjusted in the normal manner, a readout error of approximately 0.02 decibel per 10 decibels existed in addition to the error due to the system noise. The reason for the discrepancy was not determined. The error is, however, comparable to the sum of the specified errors for the reference attenuators in the Scientific-Atlanta and Weinschel receivers, which points out that the accuracy of a system is only as good as the standard used to calibrate the system. The 0.02 decibel per 10 decibel readout discrepancy could have been eliminated by readjusting the cavity Q to change the time constant of the exponential reference. The curve plotted in Figure 14 was taken from measurements made at IF with corrections for mixer conversion loss and excess noise at 3.0 GHz. The data are in agreement with data measured at 3.0 GHz after corrections are made for the 0.02 decibel per 10 decibel discrepancy.

Accurate data could not be obtained at other frequencies because of amplitude and frequency drifts in the available (commercial quality) signal sources and the Weinschel test set, and the lack of high precision, temperature stable, RF attenuators and other components. Therefore, the curves shown in Figures 15 and 16 are based on data measured at the intermediate frequency with corrections for mixer conversion loss and excess noise. The data obtained support the general shape and location of the curves shown.

Mixer non-linearities could not be measured because of limited test time and the test equipment limitations referred to previously. For fundamental mixers with a local oscillator level of one milliwatt, investigations elsewhere have found a linearity error of about 0.02 decibel at a signal level of -20 dbm and virtually negligible error at -25 dbm. The RF input level can be increased somewhat above -20 dbm without exceeding a linearity error of 0.01 decibel

by increasing the local oscillator level, but with an increasing loss in system sensitivity due to greater mixer noise. Although comparable investigations of harmonic mixers have not been found, it is expected that a similar relationship exists between fundamental local oscillator levels and high signal levels in harmonic mixers. The curves in Figures 14 through 16 are for a maximum input signal level of -25 dbm, for which it is believed the mixer linearity error is negligible. The input signal level can be increased to give increased dynamic range with some mixer non-linearity provided the IF signal level does not exceed -32 dbm.

4.3 Application of Measuring System

It was recognized from the outset that full utilization of the precision antenna-pattern measuring system would require detailed investigations into the antenna-range problem and great care in performing the measurements. Therefore, theoretical studies were initiated to investigate the major problems encountered in making very accurate measurements of the radiation characteristics of antennas. Specifically, the studies concentrated on antenna range environmental effects, antenna positioning and position-measurement problems, and parallax errors. The results of these studies are given in the reports for the Phase I study and Volume I of the final report for Phase II.

In addition to the antenna range and equipment errors and limitations previously discussed, operational errors can be significant. Some of the major sources of operational errors are:

- (a) Variations in ambient temperature
- (b) Movement of coaxial cables
- (c) Lack of mechanical stability and improper alignment of the transmitting antenna
- (d) Variations in loss of RF tuners, isolators, pads, and variable attenuators
- (e) Interference from other RF sources

A high degree of system accuracy can be expected only if the ambient temperature and humidity are maintained reasonably constant after a sufficient warm-up period. A discussion of the receiver temperature sensitivity is given in paragraph 4.2. In addition, the receiver mixer is susceptible to temperature changes, since it is located at or near the antenna (except for the frequency

range below 1.95 GHz, for which the mixer is located in the receiver), and because of the changes encountered when the antenna is moved. For measurements involving high precision, it will be necessary to insulate and shield the mixer from solar radiation. The temperature effects of the mixer are reduced, but not eliminated, by leveling the local oscillator power to maintain the crystal current constant.

Coaxial cables must be securely supported to avoid changes in cable attenuation due to cable flexing. This is particularly important in the external cables connecting the transmitter and receiver to the antennas. High-quality rotary joints must be employed in the positioner to enable the cables to remain fixed as the antenna is oriented.

It is important that the electrical axis of the transmitting antenna be aligned with the receiving antenna to provide a uniform taper across the receiving aperture. This is necessary not only to simulate proper operating conditions for the antenna under test, but also to reduce the effect of movement of the transmitting antenna on received signal level. For example, if the beamwidth of the transmitting antenna is 1 degree, and the peak of radiation pattern is aligned to a small receiving antenna, 0.03 degree movement of the transmitting antenna will cause 0.01-decibel change in the received signal level. However, if the transmitting antenna is misaligned 0.25 decibel off the peak of the beam, movement of the transmitting antenna by 0.003 degree will cause the received signal level to change by 0.01 decibel. From this example it is evident that the transmitting antenna must be accurately aligned and rigidly supported.

It will be necessary to vary the RF attenuation, either at the output of the transmitter or between the receiving antenna and the mixer, in order to set the signal level for best linearity and maximum dynamic range of the receiver. This attenuator and other RF components that may be used must be very stable in order not to degrade system performance.

It is not intended to imply by the preceding discussion that it is practical or necessary to measure radiation characteristics of antennas with an accuracy of 0.01 decibel. The receiving system was designed to meet the specified accuracy objectives so that the overall system accuracy usually will not be limited by the accuracy of the receiving system. It is often required, for

example, that a measuring instrument be ten times more accurate than the guaranteed accuracy of the device being tested. Furthermore, by advancing the state-of-art of high-speed, high-accuracy receiving and recording systems, it will be possible to make measurements and investigations that have been impractical to accomplish.

BLANK PAGE

5. CONCLUSIONS AND RECOMMENDATIONS

It has been demonstrated in tests at Scientific-Atlanta, Inc., and at Rome Air Development Center that the stabilized transmitter and precision amplitude measurement receiver form a workable system that is simple and convenient to operate, reliable, and exceptionally accurate and stable. It was not possible to determine complete specifications and capabilities, including environmental dependencies, because of the high-accuracy requirements and time and test equipment limitations. However, as far as can be determined from an evaluation of the tests, the objective specifications were met.

The logarithmic-conversion accuracy of the receiver for the low-frequency up-conversion system and for fundamental-, second-, and third-harmonic mixing is summarized by the typical mean-error curves shown in Figure 17. These curves are based on typical values of mixer conversion loss and excess noise, and do not include the linearity error of the internal reference attenuator used as the standard. The system can be adjusted for conformity to an external attenuation standard if desired.

For sampling a constant signal level at a 1-KHz rate, readout accuracy is limited primarily by count fluctuations mainly due to mixer and preamplifier noise. For typical operating conditions at fundamental mixing, the rms count fluctuation is approximately 0.06 decibel at a relative signal level of -50 decibels, and approximately 0.2 decibel at -60 decibels. The count fluctuation is reduced to approximately 0.06 decibel at -60 decibels when sampling at a 100-Hz rate in the AVERAGE mode of operation.

A dynamic error exists when measuring a changing input signal level. Calculations indicate that when sampling at a 1000-Hz rate, the dynamic error in decibels is approximately $2.5 \times 10^{-5} / \Delta S / \Delta T$, where $\Delta S / \Delta T$ is the rate of change of the input signal expressed in decibels per second.

The count fluctuation may be reduced by modifying the time-analog-to-digital converter to display the average of 100 or 1000 samples. The sampling rate would be reduced to 10 Hz and 1 Hz, respectively. This modification would improve the readout accuracy for constant or slowly varying signal levels and make the visual display easier to read.

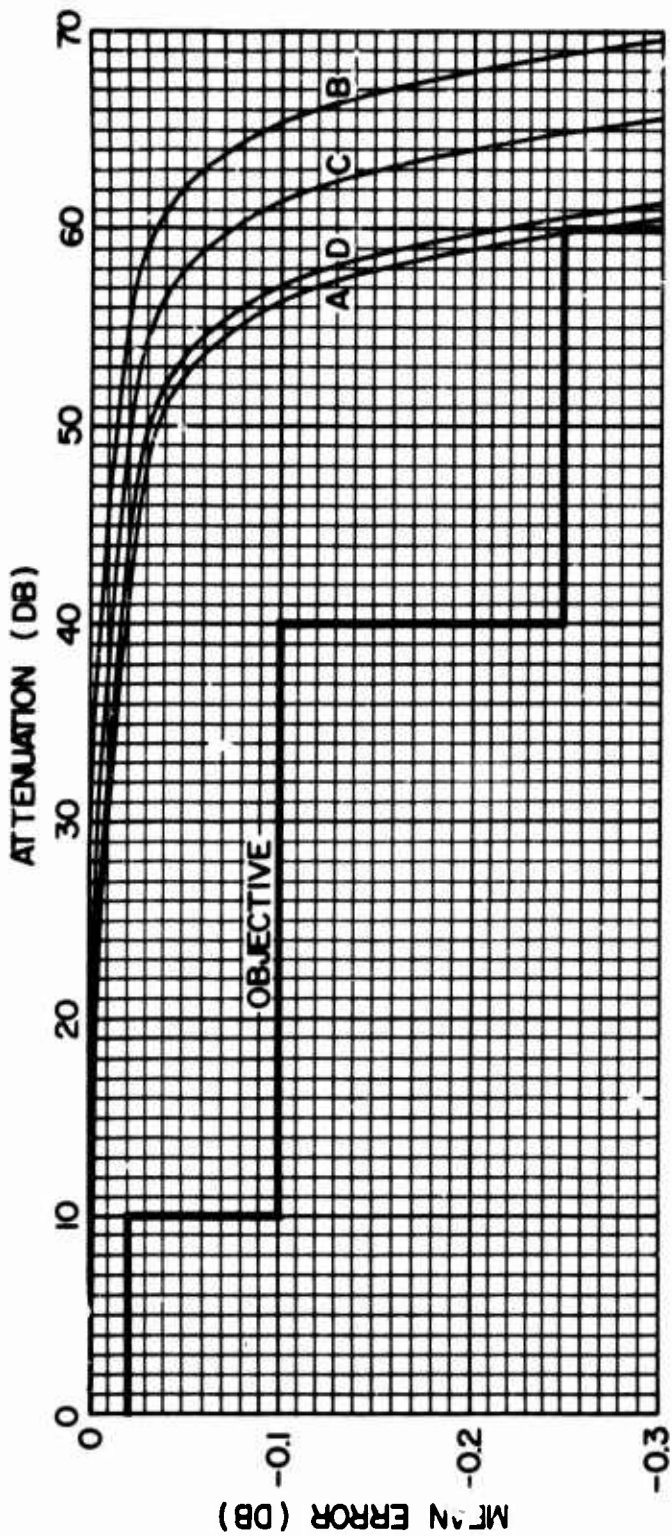

- A -- 20 MHz to 1.95 GHz
- B -- 1.95 GHz to 4.0 GHz
- C -- 4.0 GHz to 8.0 GHz
- D -- 8.0 GHz to 12.0 GHz

Figure 17
Typical Mean Error, 20 MHz to 12.0 GHz

It is recommended that the frequency range of the transmitter be extended from 1 GHz to 2 GHz by obtaining a 1- to 2-GHz RF oscillator unit similar to the 2- to 4-GHz unit, and from 4 GHz to 12 GHz by employing harmonic multipliers and TWT amplifiers. This approach would make the most use of the existing equipment and would cost the least to develop.

BLANK PAGE

Unclassified
Security Classification

DOCUMENT CONTROL DATA - R&D		
<small>(Security classification of title, body of abstract and indexing annotation must be entered when the overall report is classified)</small>		
1 ORIGINATING ACTIVITY (Corporate author) Scientific-Atlanta, Inc. Atlanta, Georgia 30324	2a REPORT SECURITY CLASSIFICATION Unclassified	
	2b GROUP	
3 REPORT TITLE INVESTIGATION OF PRECISION ANTENNA PATTERN RECORDING AND DISPLAY TECH. QUES PHASE II		
4 DESCRIPTIVE NOTES (Type of report and inclusive dates) Final Report		
5 AUTHOR(S) (Last name, first name, initial) CHUBSKA, Jack B. Pidgeon, Rezin E. Jr.		
6 REPORT DATE December 1966	7a TOTAL NO OF PAGES 57	7b NO OF PAGES
8a CONTRACT OR GRANT NO AF30(602)3425 b PROJECT NO 4506 c Task No. 450604 d	9a ORIGINATOR'S REPORT NUMBER(S) J234-FR-II 9b OTHER REPORT NO(S) (Any other numbers that may be assigned this report) RADC-TR-65-534 Vol 11	
10 AVAILABILITY LIMITATION NOTICES This document is subject to special export controls and each transmittal to foreign governments, foreign nationals or representatives thereto may be made only with prior approval of RADC (EMLI), GAFB, N.Y. 13440.		
11 SUPPLEMENTARY NOTES RADC Project Engineer: Martin Jaeger/EMATA/AC 315 330-2443	12 SPONSORING MILITARY ACTIVITY Rome Air Development Center Techniques Branch (EMAT) Griffiss AFB, NY 13440	
13 ABSTRACT <p>Volume II of the Final Report on equipment developed by Scientific-Atlanta, Inc., for RADC under Contract AF30(602)3425 is presented. The contract was for development of equipment to enhance the antenna measurement capability of ground-based antenna test ranges, and for continuation of theoretical studies initiated under Contract AF30(602)2737. The equipment developed and reported herein includes an amplitude- and frequency-stabilized signal source for the frequency range of 2 to 4 GHz and a precision, high-data-rate receiver system with logarithmic readout of data in digital and analog form. The theoretical studies reported in Volume I include an investigation of environmental effects and an analysis of parallax errors as related to high-accuracy antenna measurements; an investigation of antenna-positioning techniques and angle-measuring equipment; and a determination of optimum techniques for a high-speed precision recording system.</p>		

DD FORM 1473
1 JAN 64

Unclassified
Security Classification

Unclassified

Security Classification

14 KEY WORDS	LINK A		LINK B		LINK C	
	ROLE	WT	ROLE	WT	ROLE	WT
Measuring Devices (Electrical and Electronic) Electronic Recording Systems Ranges (Establishments)						

INSTRUCTIONS

1. **ORIGINATING AGENCY:** Enter the name and address of the contractor, subcontractor, grantee, Department of Defense activity or other organization (*corporate author*) issuing the report.

2a. **REPORT SECURITY CLASSIFICATION:** Enter the overall security classification of the report. Indicate whether "Restricted Data" is included. Marking is to be in accordance with appropriate security regulations.

2b. **GROUP:** Automatic downgrading is specified in DoD Directive 5200.10 and Armed Forces Industrial Manual. Enter the group number. Also, when applicable, show that optional markings have been used for Group 3 and Group 4 as authorized.

3. **REPORT TITLE:** Enter the complete report title in all capital letters. Titles in all cases should be unclassified. If a meaningful title cannot be selected without classification, show title classification in all capitals in parentheses immediately following the title.

4. **DESCRIPTIVE NOTES:** If appropriate, enter the type of report, e.g., interim, progress, summary, annual, or final. Give the inclusion date when a specific reporting period is covered.

5. **AUTHOR(S):** Enter the name(s) of author(s) as shown on or in the report. Enter last name, first name, middle initial. If military, show rank and branch of service. The name of the principal author is an absolute minimum requirement.

6. **REPORT DATE:** Enter the date of the report as day, month, year, or month, year. If more than one date appears on the report, use date of publication.

7a. **TOTAL NUMBER OF PAGES:** The total page count should follow normal pagination procedures, i.e., enter the number of pages containing information.

7b. **NUMBER OF REFERENCES:** Enter the total number of references cited in the report.

8a. **CONTRACT OR GRANT NUMBER:** If appropriate, enter the applicable number of the contract or grant under which the report was written.

8b, 8c, & 8d. **PROJECT NUMBER:** Enter the appropriate military department identification, such as project number, subsystem number, system numbers, task number, etc.

9a. **ORIGINATOR'S REPORT NUMBER(S):** Enter the official report number by which the document will be identified and controlled by the originating activity. This number must be unique to this report.

9b. **OTHER REPORT NUMBER(S):** If the report has been assigned any other report numbers (either by the originator or by the sponsor), also enter this number(s).

10. **AVAILABILITY LIMITATION NOTICES:** Enter any limitations on further dissemination of the report, other than those

imposed by security classification, using standard statements such as:

- (1) "Qualified requesters may obtain copies of this report from DDC."
- (2) "Foreign announcement and dissemination of this report by DDC is not authorized."
- (3) "U. S. Government agencies may obtain copies of this report directly from DDC. Other qualified DDC users shall request through _____."
- (4) "U. S. military agencies may obtain copies of this report directly from DDC. Other qualified users shall request through _____."
- (5) "All distribution of this report is controlled. Qualified DDC users shall request through _____."

If the report has been furnished to the Office of Technical Services, Department of Commerce, for sale to the public, indicate this fact and enter the price, if known.

11. **SUPPLEMENTARY NOTES:** Use for additional explanatory notes.

12. **SPONSORING MILITARY ACTIVITY:** Enter the name of the departmental project office or laboratory sponsoring (paying for) the research and development. Include address.

13. **ABSTRACT:** Enter an abstract giving a brief and factual summary of the document indicative of the report, even though it may also appear elsewhere in the body of the technical report. If additional space is required, a continuation sheet shall be attached.

It is highly desirable that the abstract of classified reports be unclassified. Each paragraph of the abstract shall end with an indication of the military security classification of the information in the paragraph, represented as (TS), (S), (C), or (U).

There is no limitation on the length of the abstract. However, the suggested length is from 150 to 225 words.

14. **KEY WORDS:** Key words are technically meaningful terms or short phrases that characterize a report and may be used as index entries for cataloging the report. Key words must be selected so that no security classification is required. Identifiers, such as equipment model designation, trade name, military project code name, geographic location, may be used as key words but will be followed by an indication of technical context. The assignment of links, rules, and weights is optional.

Unclassified

Security Classification