

UNCLASSIFIED

AD NUMBER

AD807312

LIMITATION CHANGES

TO:

Approved for public release; distribution is unlimited.

FROM:

Distribution authorized to U.S. Gov't. agencies and their contractors; Critical Technology; FEB 1967. Other requests shall be referred to National Aeronautics and Space Administration, Marshall Space Flight Center, Huntsville, AL. This document contains export-controlled technical data.

AUTHORITY

AEDC ltr, 29 May 1973

THIS PAGE IS UNCLASSIFIED

AEDC-TR-67-9

ARCHIVE COPY
DO NOT LOAN

ay1



**AEROELASTIC STABILITY
OF AN ARRAY OF FULL-SCALE PANELS
FROM THE SATURN S-IVB STAGE
AT TRANSONIC MACH NUMBERS**

PROPERTY OF U. S. AIR FORCE **T. M. Perkins**
AEDC LIBRARY
AF 40(600)1200
ARO, Inc.

February 1967

This document has been approved for public release
its distribution is unlimited. *Per A. F. Letter
dtg 29 May 73*

This document is subject to special export controls
and each transmittal to foreign governments or foreign
nationals may be made only with prior approval of
National Aeronautics and Space Administration (MSFC),
Huntsville, Alabama.

**PROPULSION WIND TUNNEL FACILITY
ARNOLD ENGINEERING DEVELOPMENT CENTER
AIR FORCE SYSTEMS COMMAND
ARNOLD AIR FORCE STATION, TENNESSEE**

AEDC TECHNICAL LIBRARY



PROPERTY OF U. S. AIR FORCE
AEDC LIBRARY
AF 40(600)1200

NOTICES

When U. S. Government drawings, specifications, or other data are used for any purpose other than a definitely related Government procurement operation, the Government thereby incurs no responsibility nor any obligation whatsoever, and the fact that the Government may have formulated, furnished, or in any way supplied the said drawings, specifications, or other data, is not to be regarded by implication or otherwise, or in any manner licensing the holder or any other person or corporation, or conveying any rights or permission to manufacture, use, or sell any patented invention that may in any way be related thereto.

Qualified users may obtain copies of this report from the Defense Documentation Center.

References to named commercial products in this report are not to be considered in any sense as an endorsement of the product by the United States Air Force or the Government.

AEROELASTIC STABILITY
OF AN ARRAY OF FULL-SCALE PANELS
FROM THE SATURN S-IVB STAGE
AT TRANSONIC MACH NUMBERS

- 1. Project Saturn S-IVB
- 2 Panels -- Flutter
- 3 4 --

T. M. Perkins
ARO, Inc.

*aeroelastic
stability*

This document has been approved for public release
its distribution is unlimited. *Per A.A. Letter
dated 29 May
73.*

1-1

This document is subject to special export controls
and each transmittal to foreign governments or foreign
nationals may be made only with prior approval of
National Aeronautics and Space Administration (MSFC),
Huntsville, Alabama.

FOREWORD

The work reported herein was performed at the request of the National Aeronautics and Space Administration (NASA), Marshall Space Flight Center (MSFC) under System 921E.

The results of the tests presented were obtained by ARO, Inc. (a subsidiary of Sverdrup & Parcel and Associates, Inc.), contract operator of the Arnold Engineering Development Center (AEDC), Air Force Systems Command (AFSC), Arnold Air Force Station, Tennessee, under Contract AF40(600)-1200. The tests were conducted on September 19 and 20 and October 5 through 10, 1966, under ARO Project No. PB1654, and the manuscript was submitted for publication on December 28, 1966.

Information in this report is embargoed under the Department of State International Traffic in Arms Regulations. This report may be released to foreign governments by departments or agencies of the U. S. Government subject to approval of the National Aeronautics and Space Administration, Marshall Space Flight Center, or higher authority. Private individuals or firms require a Department of State export license.

This technical report has been reviewed and is approved.

Richard W. Bradley
Lt Col, USAF
AF Representative, PWT
Directorate of Test

Leonard T. Glaser
Colonel, USAF
Director of Test

ABSTRACT

Flutter characteristics of a 30-deg segment of the full-scale Saturn S-IVB stage were obtained at Mach numbers from 1.10 to 1.40 for various combinations of axial-compressive loads and panel differential pressures. Flutter was encountered when sufficient axial load was applied to either partially or completely buckle the panels. No structural failure occurred on any of the panels during this test. Static-pressure and boundary-layer surveys were made on a rigid panel at tunnel conditions comparable to those of the flutter phase.

CONTENTS

| | <u>Page</u> |
|---|-------------|
| ABSTRACT | iii |
| NOMENCLATURE | vi |
| I. INTRODUCTION | 1 |
| II. APPARATUS | |
| 2.1 Wind Tunnel | 1 |
| 2.2 Test Article | 1 |
| 2.3 Instrumentation | 3 |
| III. TEST PROCEDURES | |
| 3.1 Pressure Phase | 4 |
| 3.2 Flutter Phase | 4 |
| 3.3 Precision of Measurements | 4 |
| IV. RESULTS AND DISCUSSION | |
| 4.1 Pressure Phase | 5 |
| 4.2 Flutter Phase | 5 |
| V. CONCLUSIONS | 6 |
| REFERENCES | 7 |

APPENDIXES

I. ILLUSTRATIONS

Figure

| | |
|--|----|
| 1. Schematic of Tunnel 16T Test Section Showing Model Location | 11 |
| 2. Photograph of Pressure Model Installed in Tunnel 16T, Boundary-Layer Rake in Forward Position | 12 |
| 3. Photograph of Flutter Model Installed in Tunnel 16T. . . | 13 |
| 4. Details of Test Fixture with Flutter Panel Installed . . . | 14 |
| 5. Details of Test Panels | |
| a. Pressure Panel | 15 |
| b. Flutter Panel | 16 |
| 6. Boundary-Layer Rake | 17 |
| 7. Static Buckling of Flutter Panel | 18 |
| 8. Instrumentation Layout for Flutter Phase | 19 |
| 9. Variation of Reynolds Number with Mach Number for Pressure Phase | 20 |

| <u>Figure</u> | <u>Page</u> |
|--|-------------|
| 10. Boundary-Layer Profiles | |
| a. Rake Forward, $x/L = 0.0387$ | 21 |
| b. Rake Center, $x/L = 0.5342$ | 21 |
| c. Rake Aft, $x/L = 0.9358$ | 21 |
| 11. Variation of Boundary-Layer Characteristics with Rake Position and Mach Number | |
| a. Low Reynolds Number Level | 22 |
| b. High Reynolds Number Level | 23 |
| 12. Variation of Pressure Coefficients along the Pressure Panel | |
| a. $M_\infty = 1.10$ | 24 |
| b. $M_\infty = 1.20$ | 25 |
| c. $M_\infty = 1.30$ | 26 |
| d. $M_\infty = 1.35$ | 27 |
| 13. Variation of Maximum Dynamic Pressure with Mach Number for Flutter Phase. | 28 |
| 14. Variation of Dynamic Pressure with Axial-Compressive Panel Load | |
| a. $\Delta p_c = 0.5$ | 29 |
| b. $\Delta p_c = 0.3$ | 30 |
| 15. Oscillograph Trace Showing Panel Flutter | 31 |
| 16. Variation of the Flutter Parameter with Panel Buckling Load Ratio at $M_\infty = 1.40$ | 32 |

II. TABLE

| | |
|--|----|
| I. Summary of Flutter Boundary Results | 33 |
|--|----|

NOMENCLATURE

| | |
|-----------|--|
| BLR | Boundary-layer rake |
| C_p | Pressure coefficient, $\frac{p - p_\infty}{q_\infty}$ |
| E | Young's modulus of elasticity, 10.5×10^6 psi |
| \bar{F} | Flutter parameter, $\left(\frac{144E\sqrt{M_\infty^2 - 1}}{q_\infty} \right)^{1/3} \frac{t}{l}$ |

| | |
|----------------|---|
| f | Panel flutter frequency, cps |
| L | Pressure panel length, in. (Fig. 5a) |
| l | Panel length in each of five bays, in. (Fig. 5b) |
| M_∞ | Free-stream Mach number |
| P_{cr} | Critical buckling load for each bay, lb |
| P_H | Axial-compressive load applied to panels, lb. |
| p | Local static pressure on panel surface, psf |
| p_{47} | Static pressure on rigid access panel, psi (Fig. 5b) |
| p_c | Panel cavity pressure, psi |
| P_{t_∞} | Free-stream total pressure, psf |
| p_∞ | Free-stream static pressure, psf |
| q_∞ | Free-stream dynamic pressure, psf |
| R | Panel radius, 130 in. |
| Re/ft | Reynolds number per foot, U_∞/ν_∞ |
| T_{ta} | Tunnel total temperature, °F |
| t | Panel skin thickness, 0.035 in. |
| U_∞ | Free-stream velocity, ft/sec |
| u | Local velocity, ft/sec |
| w | Width of panel, in. |
| x | Distance from forward edge of pressure panel, in. |
| y | Vertical distance above panel surface, in. |
| Δp_c | Differential pressure across test panel, ($p_c - p_{47}$), psi |
| δ | Boundary-layer thickness to $u/U_\infty = 0.98$, in. |
| δ^* | Boundary-layer displacement thickness, in., $\int_0^\delta \left(1 - \frac{\rho u}{\rho_\infty U_\infty}\right) (1 + y/R) dy$ |
| θ | Boundary-layer momentum thickness, in., $\int_0^\delta \frac{\rho u}{\rho_\infty U_\infty} \left(1 - \frac{u}{U_\infty}\right) (1 + y/R) dy$ |
| ϕ | Angular coordinate of circumferential ray of static pressure orifices on pressure panel, deg |

ρ Local density, slugs/ft³
 ρ_{∞} Free-stream density, slugs/ft³
 ν_{∞} Free-stream kinematic viscosity, ft²/sec

SUBSCRIPTS

1, 2, 5 Bays 1 through 5 on flutter model, Fig. 5b
c Cavity
cr Critical

SECTION I INTRODUCTION

The Saturn S-IVB Panel Flutter test was conducted in the Propulsion Wind Tunnel, Transonic (16T) at Mach numbers from 1.10 to 1.40. The test was divided into a pressure phase and a flutter phase.

The purpose of the pressure phase was to determine the boundary-layer characteristics and static-pressure distributions over a rigid panel for use in interpreting the flutter results.

The objective of the flutter phase was to determine the flutter characteristics of a full-scale 30-deg segment of skin panels for various combinations of panel axial-compressive loads and internal cavity pressures.

SECTION II APPARATUS

2.1 WIND TUNNEL

Tunnel 16T is a variable density wind tunnel. The test section is 16 ft square by 40 ft long with perforated walls to allow continuous operation through the Mach number range from 0.55 to 1.60 with minimum wall interference. A more complete description of the tunnel can be found in Ref. 1.

Details of the perforated walls and the location of the floor-mounted model in the test section are shown in Fig. 1. Photographs of the pressure and flutter models installed are presented in Figs. 2 and 3, respectively.

2.2 TEST ARTICLE

Both the pressure and flutter panels were tested using the same mounting fixture, a detail drawing of which is shown in Fig. 4. This mounting fixture was composed of four basic sections: the 8-deg leading-edge ramp, the two side-support struts, a center section containing a cavity, and a base section. The leading-edge ramp was designed to produce, as nearly as possible, uniform flow over the fixture and test panels and to divert the test section's boundary layer into the opening in the tunnel floor below the fixture (Fig. 3).

The function of the side-support struts and the center section was to support either the rigid pressure or flexible flutter panels. The center section was constructed as a pressure vessel in order to maintain a positive pressure differential across the panels during the flutter phase. The base section was composed of a boattail fairing as shown in Fig. 4 which was designed to reduce the strength of the wake. This boattail fairing was not available for the pressure phase but was utilized during the flutter phase of the test.

Details of the rigid test panel (pressure panel) and the flutter panel are presented in Fig. 5. The pressure panel was constructed from 0.125-in. 4130 steel with three rows of static-pressure orifices equidistant from the external stiffeners which are shown in Fig. 5a. The boundary-layer rake shown in Fig. 6 was placed at three different positions on the rigid panel during the pressure phase.

Details of the flutter panel are presented in Fig. 5b. A 30-deg segment of the forward portion of the S-IVB stage was modified to incorporate a steel bulkhead at each end. Eight remotely controlled hydraulic jacks were placed at each end of the array of panels and connected to the steel bulkheads to apply the axial-compressive loads. The jacks were attached to a manifold line at either end of the segment of panels in order to equalize the pressure in all jacks. The amount of axial-compressive load applied to the array of panels was varied from 0 to 40,000 lb.

A sponge rubber seal was placed along the bottom of each of the two end bulkheads and along the side frames to maintain a pressure seal around the array of flexible panels. An automatic regulator valve was connected to a 1/2-in. nitrogen line in order to control the pressure in the cavity below the flutter panels.

The array of panels was divided into five bays with seven panels per bay as shown in Fig. 5b. All panels were constructed from 0.035-in. -thick 7076-T6 aluminum skin and were riveted to internal ring stiffeners and externally mounted hat sections for longitudinal stiffness.

Figure 7 is a photograph of the flexible array of panels showing the static buckling (wind-off condition) in panels 207, 208, 210, and 211 when the axial-compressive load was approximately 40,000 lb.

2.3 INSTRUMENTATION

2.3.1 Pressure Phase

Forty-three static pressure orifices were uniformly distributed along three rays on the panel, and nine microphones were located elsewhere on the panel as shown in Fig. 5a. All of the pressure orifices were connected to pressure transducers which were located in the tunnel plenum chamber. All transducer outputs were fed into analog-to-digital converters and then to a digital computer.

One boundary-layer rake was used to measure the boundary-layer thickness at three locations on the pressure panel. The 26 total-pressure lines on the rake were connected to similar transducers whose outputs were introduced into the computer in the same manner as the static-pressure outputs from the panel.

2.3.2 Flutter Phase

The 35 flexible flutter panels were instrumented with thirty-one 120-ohm strain-gage bridges, eight accelerometers, and five microphones as shown in Fig. 5b. Four of the microphones were mounted flush with the surface and the fifth one was attached to the floor of the pressure cavity. The rigid access panel just forward of the flutter panels in Fig. 5b was instrumented with a static-pressure orifice, an accelerometer, and a microphone.

The signals from the strain gages, microphones, and accelerometers were amplified and fed into two magnetic tape recorders and an oscillograph with a quick processing magazine. The information obtained from the tape recorders and oscillograph consisted of panel frequencies, noise levels in the boundary-layer and pressure cavity, and acceleration levels of the structure in the vicinity of the microphones.

A transducer was connected between the p_{47} orifice (Fig. 5b) on the rigid access panel and the panel cavity pressure. The transducer's output was fed into an on-line recorder and the automatic regulator valve. This allowed continuous monitoring and control of the pressure differential across the flutter panel.

A schematic of the instrumentation layout for the flutter phase is presented in Fig. 8.

SECTION III TEST PROCEDURES

3.1 PRESSURE PHASE

Static-pressure distributions and boundary-layer profiles were obtained at Mach numbers from 1.10 to 1.35 for Reynolds numbers of approximately 1.63×10^6 to 3.50×10^6 /ft (Fig. 9). Data were obtained with the boundary-layer rake mounted in the forward, center, and aft positions on the pressure panel (Fig. 5a).

3.2 FLUTTER PHASE

The Mach numbers were established at 1.10, 1.20, 1.30, and 1.40 at low dynamic pressures. The dynamic pressure was slowly increased, while maintaining a constant Mach number, until either the maximum value or a designated limit was reached. The pressure differential (Δp_c) across the panels was maintained at 1.0, 0.5, and 0.3 psi with and without axial-compressive loads applied to the array of panels during the flutter investigation.

The flutter boundaries were defined for 0.5- and 0.3-psi pressure differentials across the panels by increasing the axial-compressive loading for different levels of dynamic pressure while maintaining a constant Mach number.

3.3 PRECISION OF MEASUREMENTS

The magnitude of the uncertainties involved in the tunnel conditions is estimated to be as follows:

| | |
|-------------------|-----------------------|
| Mach number | ± 0.005 |
| Total pressure | ± 5 psf |
| Dynamic pressure | ± 0.5 percent |
| Total temperature | $\pm 5^\circ\text{F}$ |

The magnitude of the uncertainties in panel frequency measurements as recorded on oscillograph records is estimated to be 10 percent.

SECTION IV RESULTS AND DISCUSSION

4.1 PRESSURE PHASE

Boundary-layer profiles (Fig. 10) were measured at forward, center, and aft rake locations on the rigid pressure panel at Mach numbers from 1.10 to 1.35 for two Reynolds number levels.

Boundary-layer characteristics were computed from the profile data for both Reynolds number levels and are presented in Fig. 11. The boundary-layer height, displacement, and momentum thicknesses increased with downstream distance from the panel's leading edge. The displacement thickness varied from an average value of 0.65 in. at $x/L = 0.0387$ to 1.32 in. at $x/L = 0.9358$ as shown in Fig. 11b.

The variation in pressure coefficient (C_p) with x/L at Mach numbers from 1.10 to 1.35 is presented in Fig. 12. A reasonably uniform distribution is evident up to $x/L = 0.80$ at $M_\infty = 1.10$ and $x/L = 0.85$ at $M_\infty = 1.20$ to 1.35. The positive increase in C_p at higher x/L values indicates the presence of a shock wave with flow separation just ahead of the external ring frame at the trailing edge of the pressure panel.

4.2 FLUTTER PHASE

The array of 0.035-in. aluminum panels was tested at Mach numbers from 1.10 to 1.40 for various combinations of panel differential pressure and axial-compressive panel loads. A summary of the test results at the flutter boundary is presented in Table I for each Mach number.

Figure 13 presents the maximum dynamic pressure obtained at each test Mach number for the various panel differential pressures with axially unloaded panels ($P_H = 0$). Flutter was not encountered on any of the panels in the array for $P_H = 0$ at the conditions presented in Fig. 13.

Flutter boundaries in terms of free-stream dynamic pressure for panels in the first and second bays are presented in Fig. 14 for a range of panel axial-compressive loads at $\Delta p_c = 0.5$ and 0.3 psi. As axial-compressive load was increased, the dynamic pressure required to initiate flutter of panels in the first bay decreased until a minimum point was reached at approximately twice the value of the wind-off static buckling value (P_{cr1}). An apparent suppression of buckling in the

presence of supersonic flow has been verified theoretically for flat panels in Ref. 2. It is believed that the occurrence of a minimum in the flutter boundary at twice the critical buckling load is an experimental verification of this suppression.

The effect of increasing Mach number from 1.20 to 1.40 is shown in Fig. 14 to reduce the minimum dynamic pressure and axial-compressive load at which flutter begins in the first bay.

Panels 201 and 202 (Fig. 5b) were the first to develop flutter in the first bay and likewise panels 204 and 205 in the second bay. High-speed motion pictures indicated a traveling wave mode of flutter existed and that panel cascading (Ref. 3) occurred since all panels in each bay fluttered after one panel in that bay began to flutter. In all cases the amplitude of the panel flutter varied directly with the applied compressive load and did not yield any structural divergence. Moreover, no evidence of panel fatigue cracks or rivet failures was found during or after the test. Figure 15 presents a typical oscillograph trace showing flutter on the panels in bays one and two with an axial-compressive load of 35,000 lb.

Figure 16 shows the variation of the flutter parameter (\bar{F}) with the ratio of axial-compressive load to buckling load at $M_\infty = 1.40$ for panels in the first bay with differential pressures of 0.5 and 0.3 psi. Reducing the panel differential pressure reduced the dynamic pressure at flutter for a constant Mach number and buckling load ratio. Increasing the buckling load ratio is destabilizing up to a value of approximately two at which point the panels become more stable with increased P_H/P_{cr1} values. The values of \bar{F} compare favorably with those in Ref. 3, which were obtained on a similar segment of panels with external "hat-sections" and internal ring frames.

SECTION V CONCLUSIONS

The following conclusions were derived from this test:

1. The array of panels was flutter free for the test dynamic pressures and Mach numbers with no applied axial-compressive load in the panels for pressure differentials of 1.0, 0.5, and 0.3 psi.
2. A traveling wave mode of flutter occurred on all panels in the first and second bays with axial-compressive loads applied as the result of panel buckling at reduced cavity pressure at

$M_\infty = 1.20, 1.30, \text{ and } 1.40$. The flutter mode was amplitude limited which resulted in no structural failures or fatigue cracks appearing in the array of panels.

3. Increasing the axial-compressive load to approximately twice the panel static buckling value reduced the minimum dynamic pressure at which flutter occurred at Mach numbers of 1.20, 1.30, and 1.40.
4. Decreasing the pressure differential across the panels reduced the minimum dynamic pressure at which flutter occurred.

REFERENCES

1. Test Facilities Handbook (6th Edition). "Propulsion Wind Tunnel Facility, Vol. 5." Arnold Engineering Development Center, November 1966.
2. Dixon, Sidney C. "Applications of Transtability Concepts to Flutter of Finite Panels and Experimental Results." NASA TND-1948, September 1963.
3. Walker, Robert W., Rosecrans, Richard, and DeVeikis, William D. "Flutter Investigation of Streamwise-Oriented Arrays of Curved Panels under Compressive Loading and Aerodynamic Heating." NASA TND-2910, July 1965.

APPENDIXES
I. ILLUSTRATIONS
II. TABLE

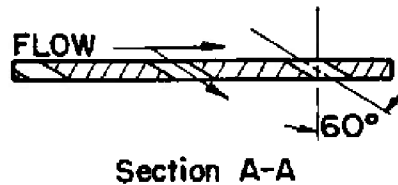
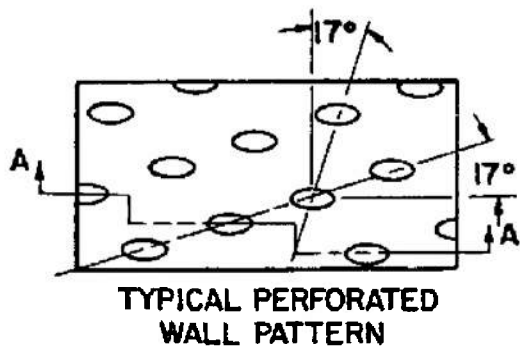

6% Open Area
 Hole Diameter = 0.75 In.
 Plate Thickness = 0.75 In.

11

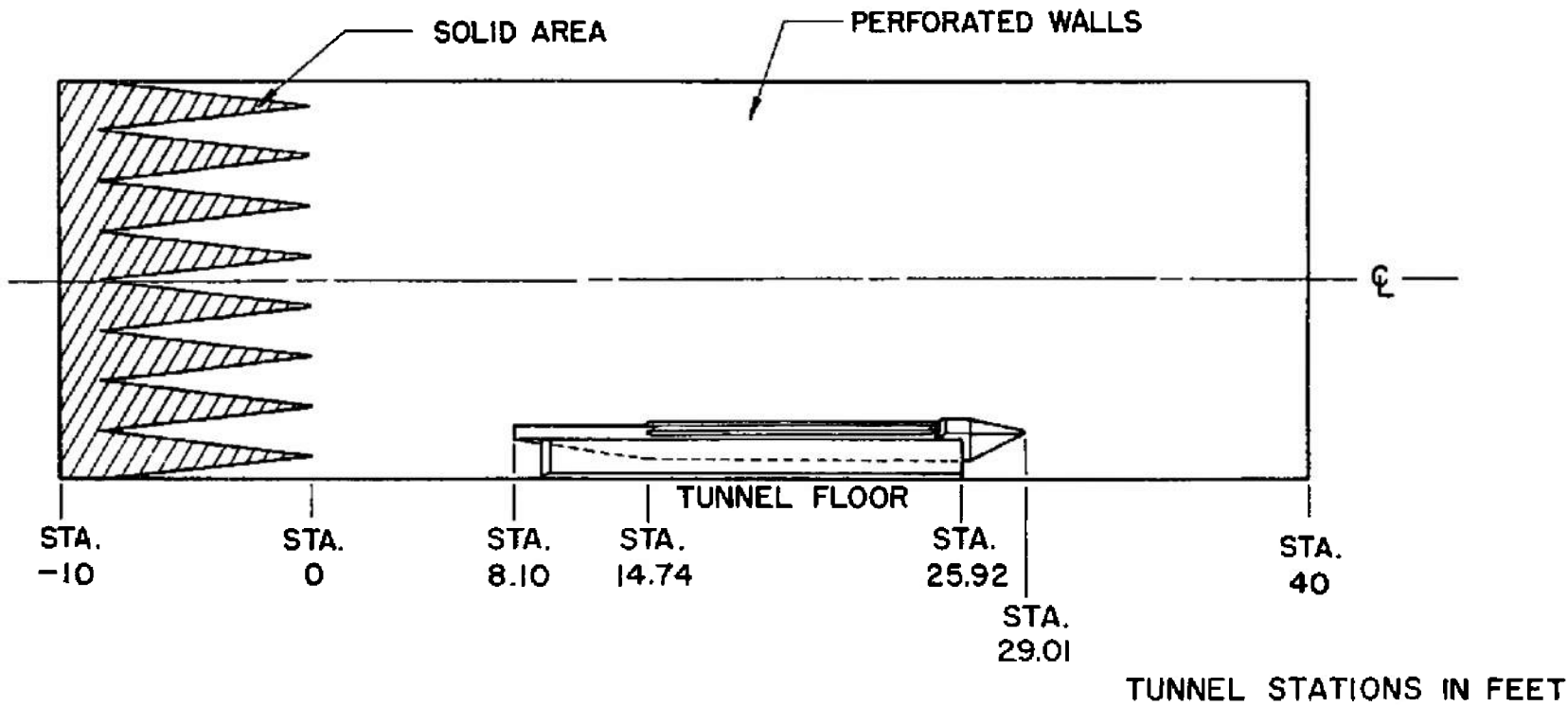

Fig. 1 Schematic of Tunnel 16T Test Section Showing Model Location

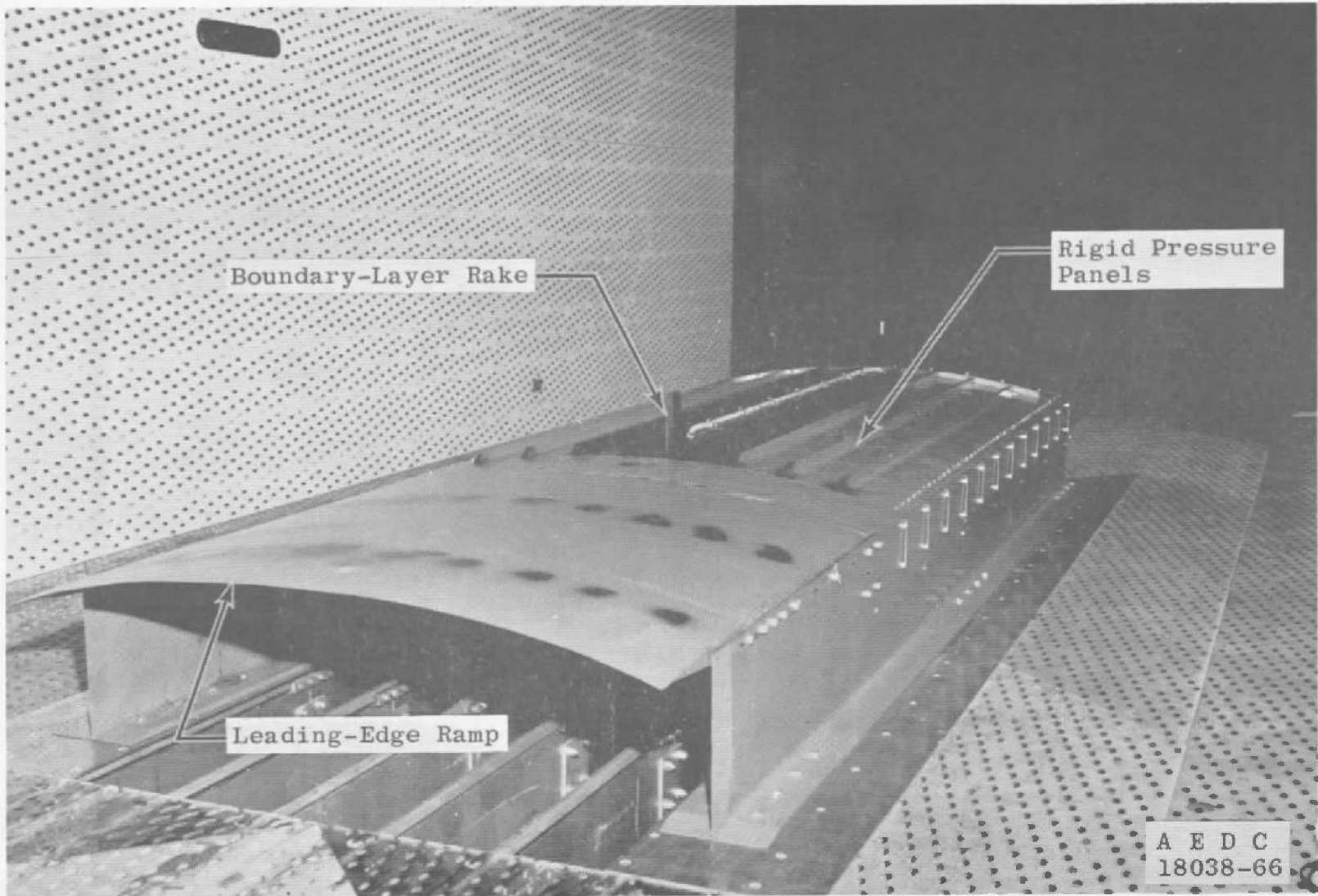

Fig. 2 Photograph of Pressure Model Installed in Tunnel 16T, Boundary-Layer Rake in Forward Position



Fig. 3 Photograph of Flutter Model Installed in Tunnel 16T

14

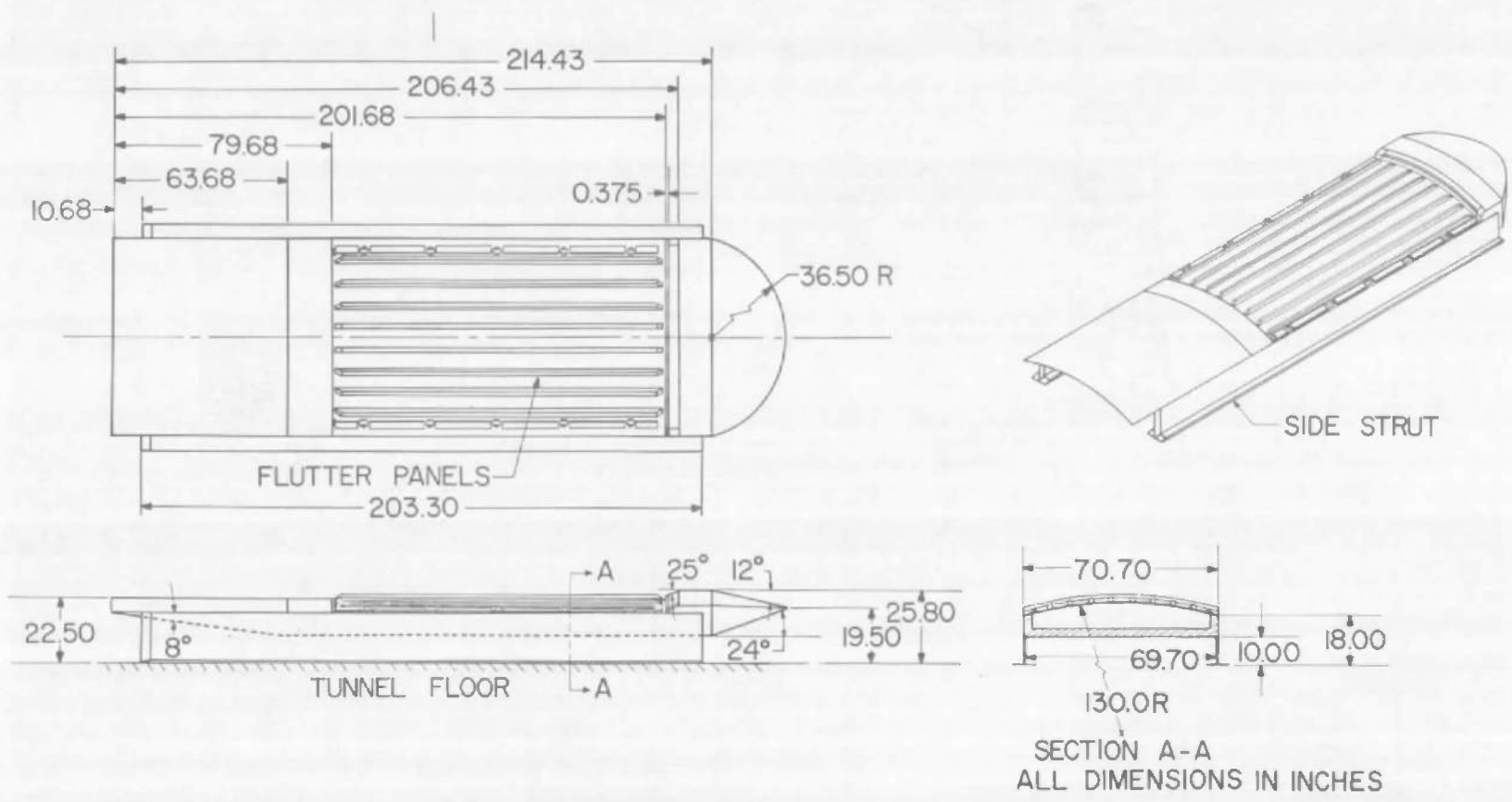
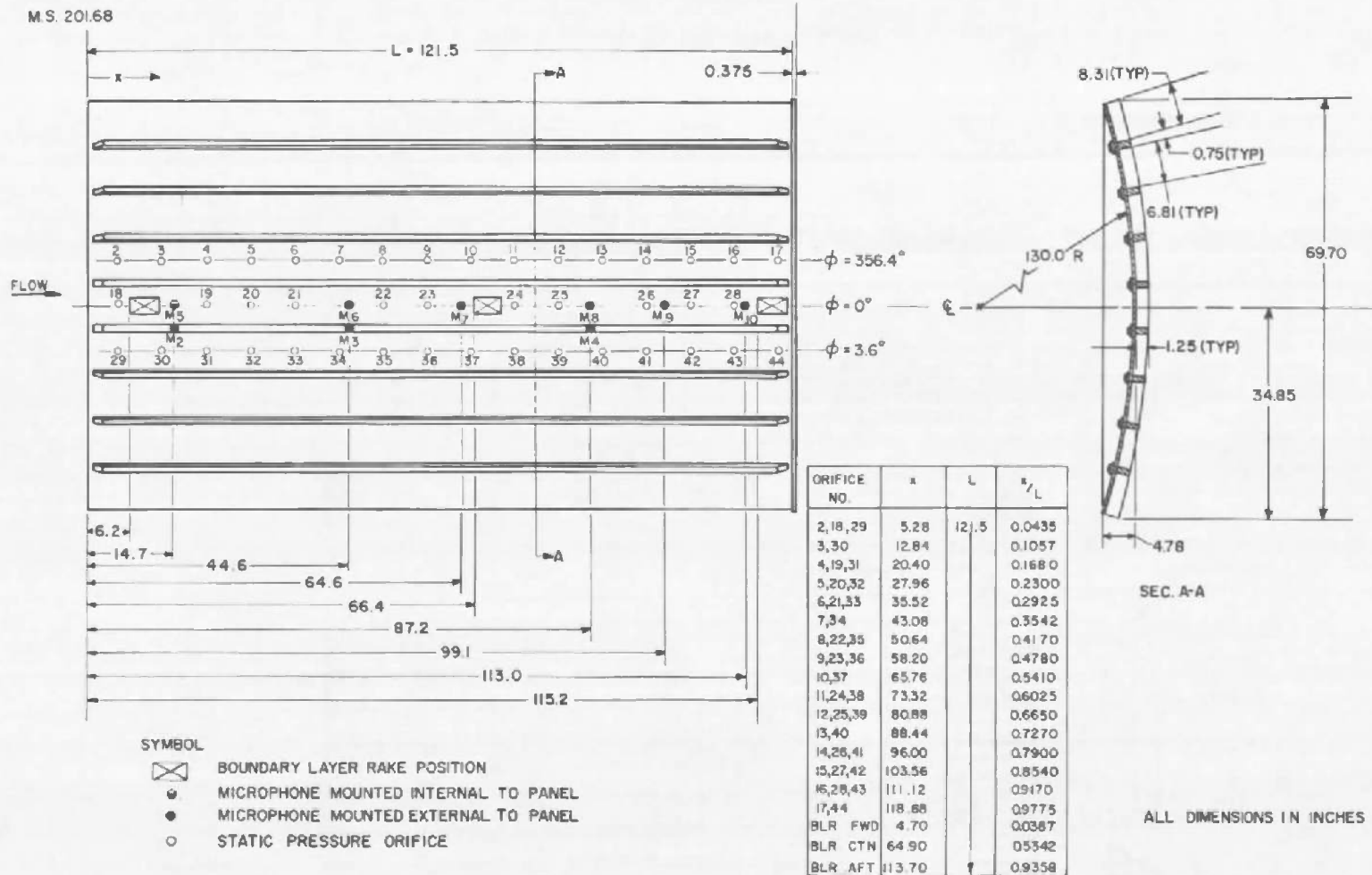
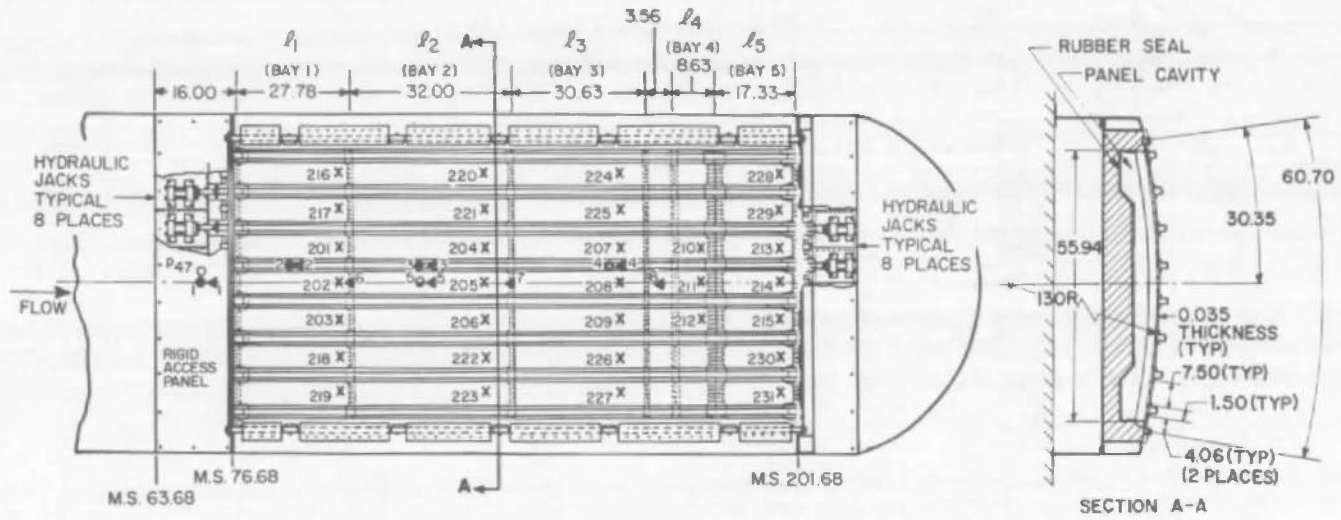

Fig. 4 Details of Test Fixture with Flutter Panel Installed



a. Pressure Panels
 Fig. 5 Details of Test Panels



| SYMBOL NUMBER | LOCATION (M.S.) |
|--|-----------------|
| 1, 1, 47 | 73.68 |
| 2, 2 | 94.38 |
| 201, 202, 203, 216, 217, 218, 219, | 102.96 |
| 6 | 107.46 |
| 3, 3, 5, 5 | 124.28 |
| 204, 205, 206, 220, 221, 222, 223 | 135.46 |
| 7 | 139.46 |
| 207, 208, 209, 224 225, 226, 227, 4, 4 | 166.09 |
| 8 | 171.87 |
| 210, 211, 212 | 179.28 |
| 213, 214, 215, 228, 229, 230, 231 | 198.95 |

- SYMBOL
- X STRAIN GAGE
 - MICROPHONE MOUNTED EXTERNALLY TO PANEL
 - MICROPHONE MOUNTED INTERNALLY TO PANEL
 - ▲ ACCELEROMETER MOUNTED BELOW MICROPHONE
 - STATIC PRESSURE ORIFICE FOR p47

ALL DIMENSIONS IN INCHES

b. Flutter Panel
Fig. 5 Concluded

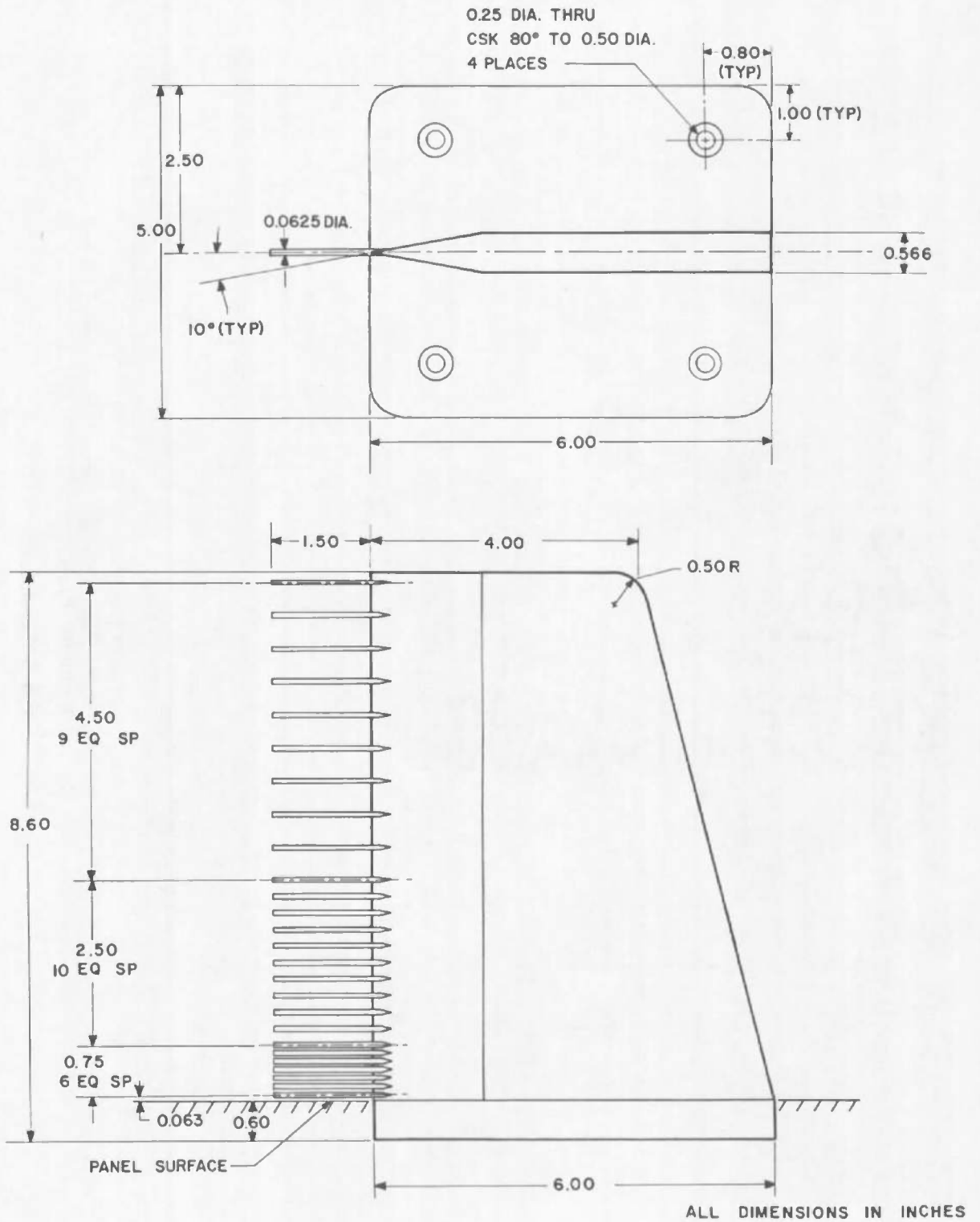

Fig. 6 Boundary-Layer Rake

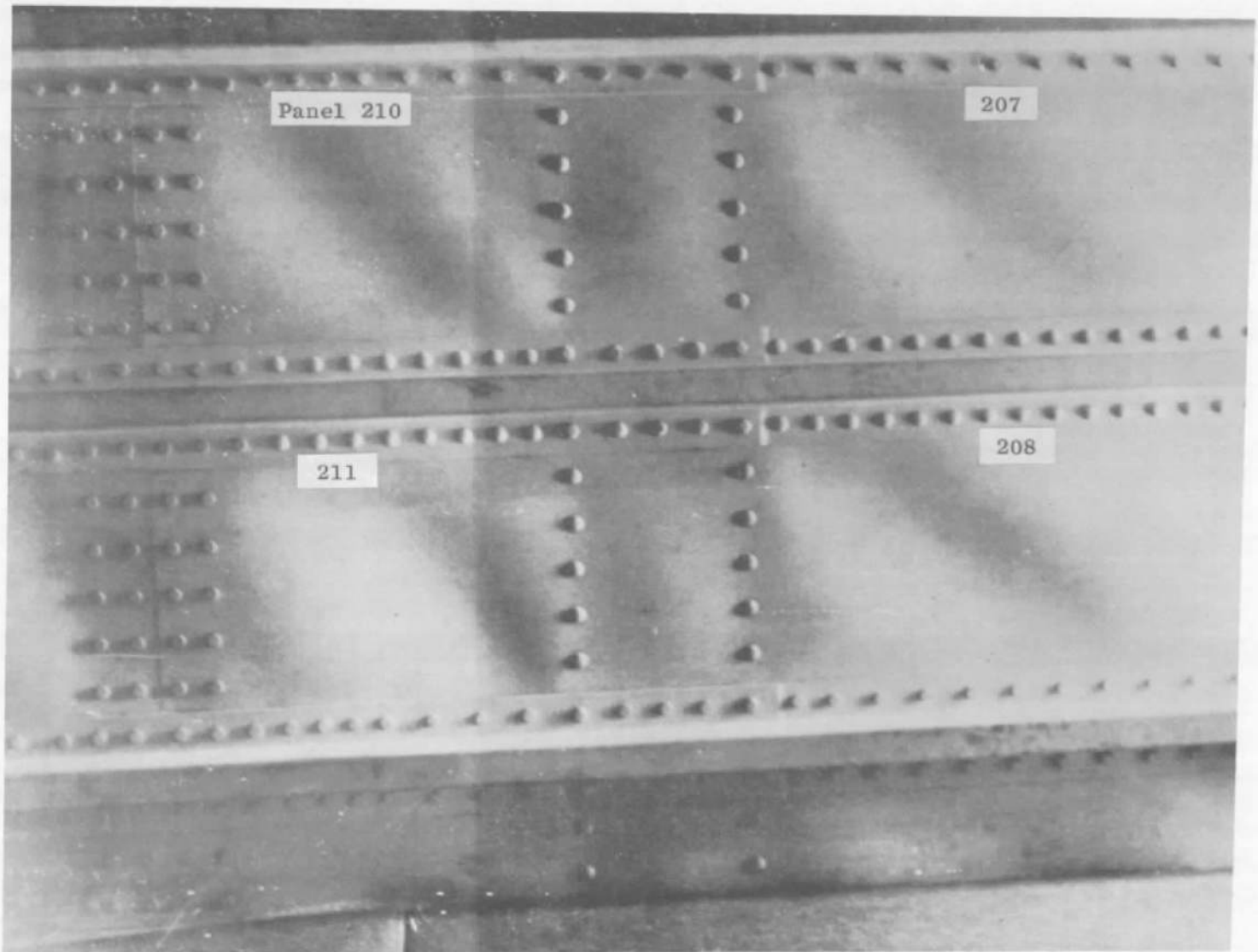

Fig. 7 Static Buckling of Flutter Panel

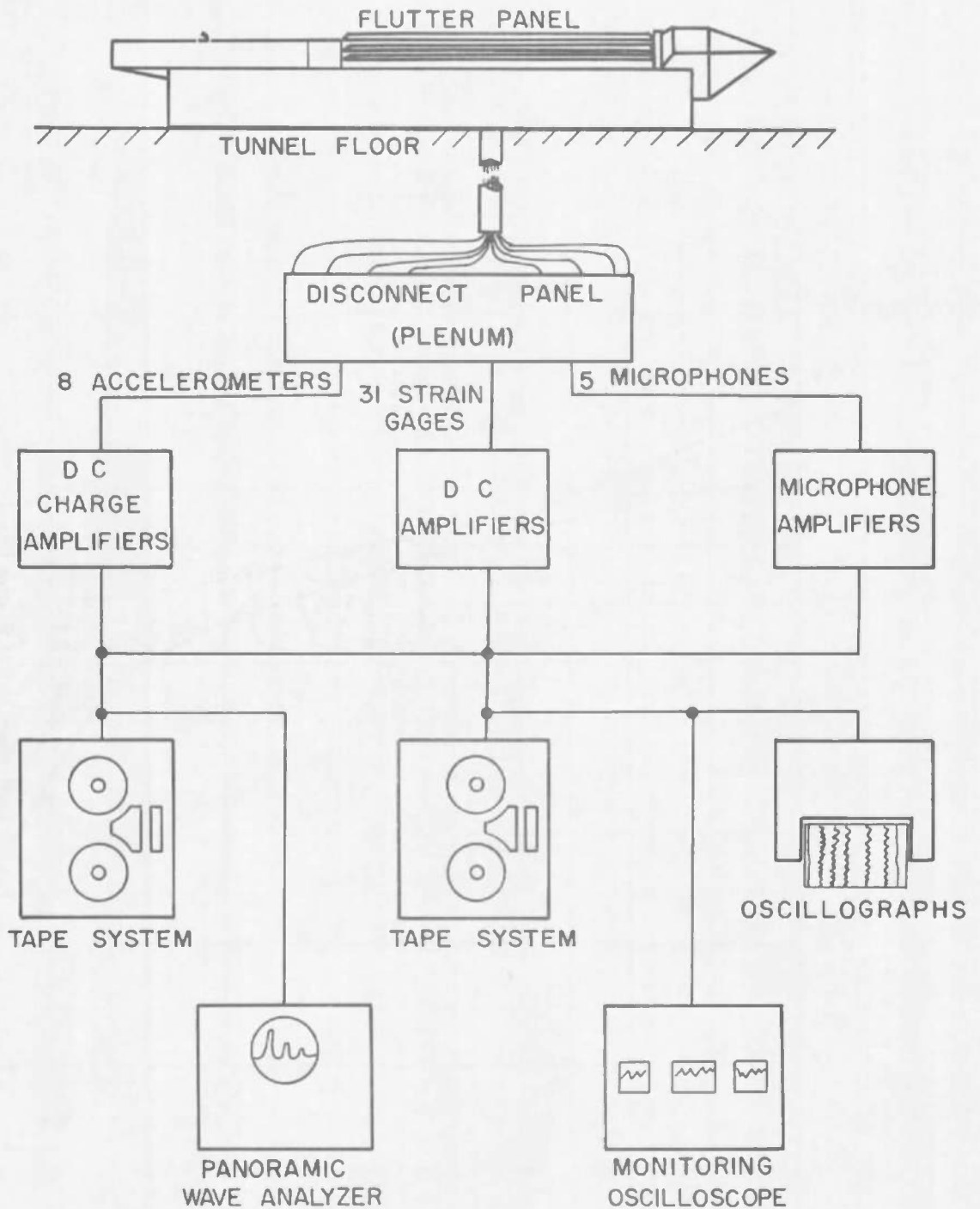

Fig. 8 Instrumentation Layout for Flutter Phase

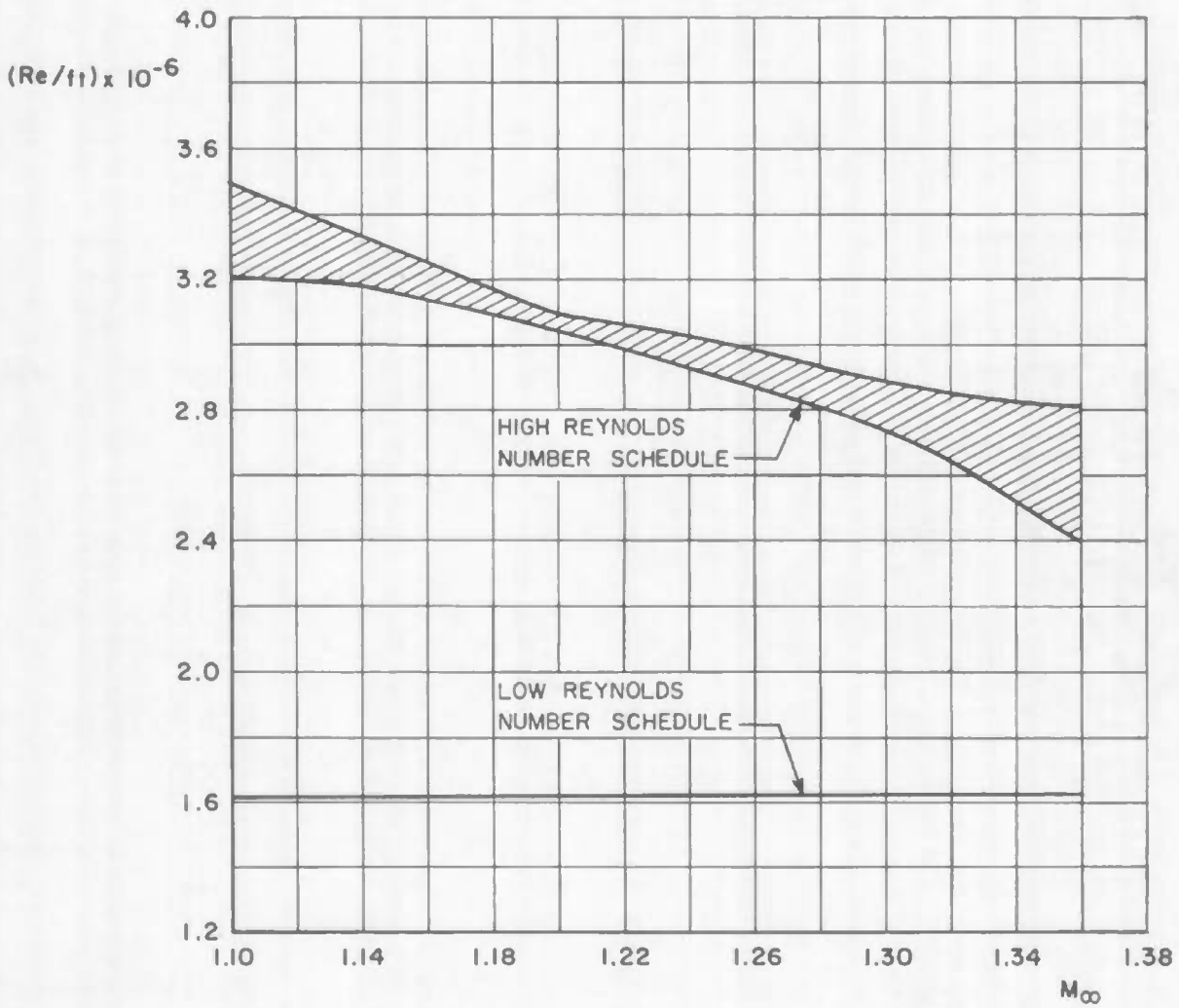

Fig. 9 Variation of Reynolds Number with Mach Number for Pressure Phase

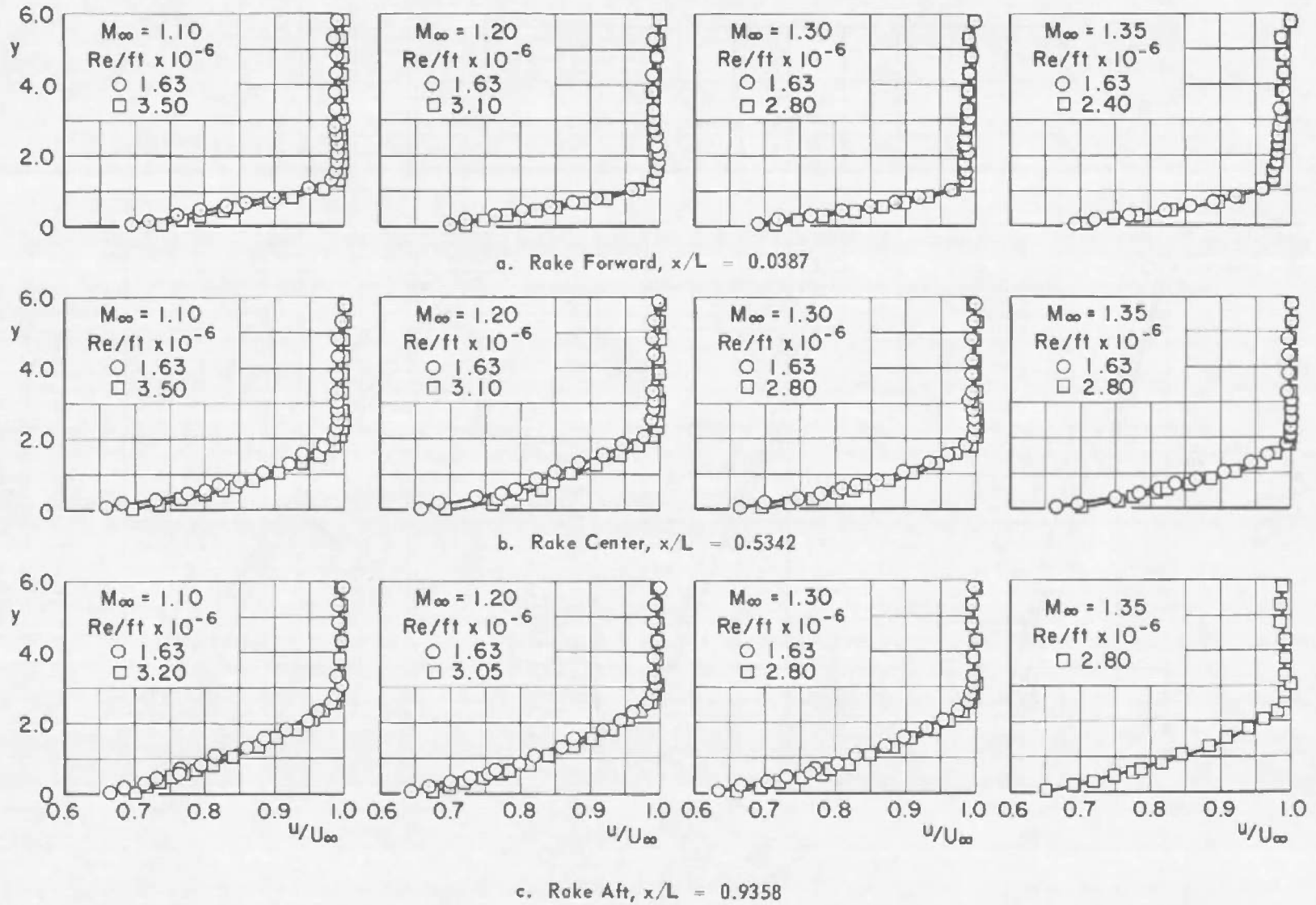

Fig. 10 Boundary-Layer Profiles

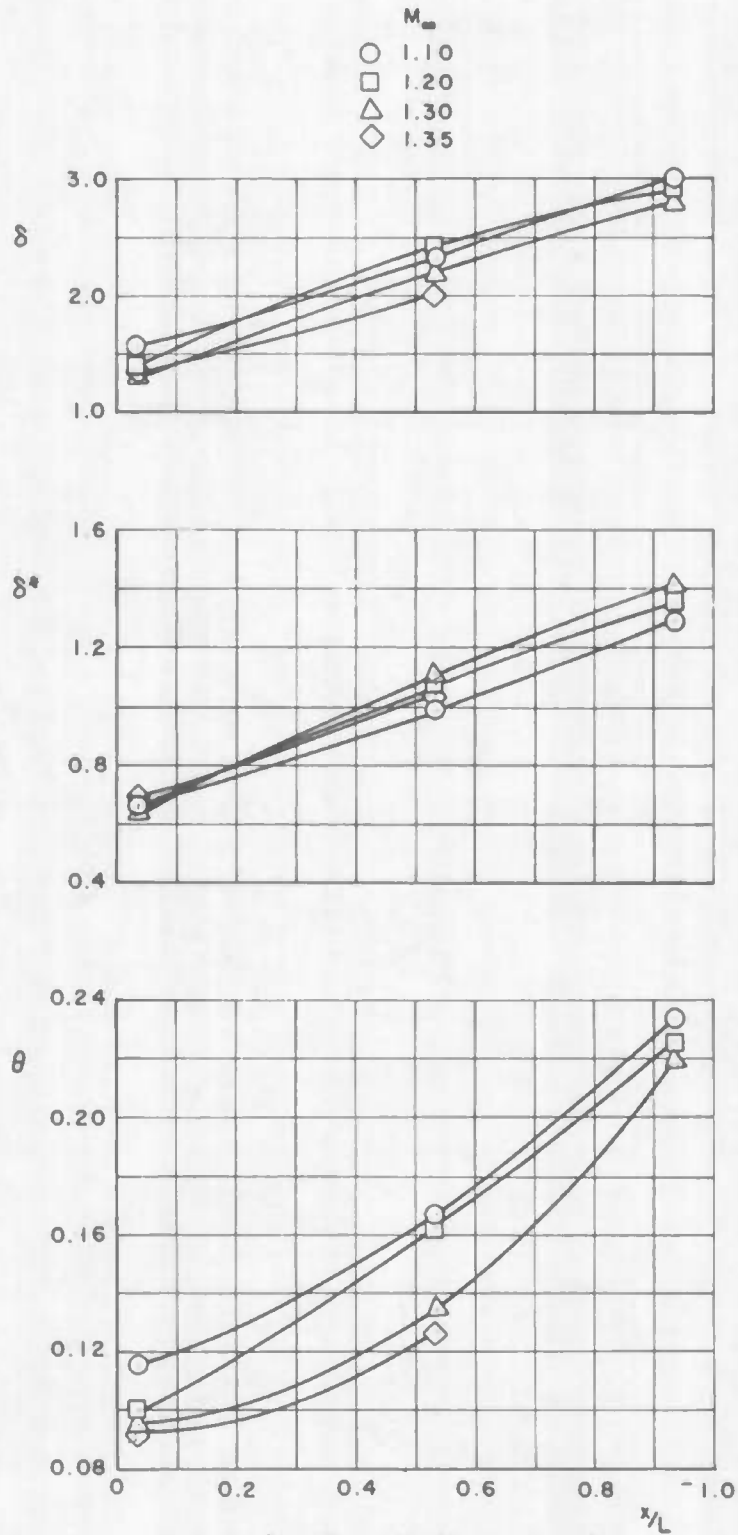
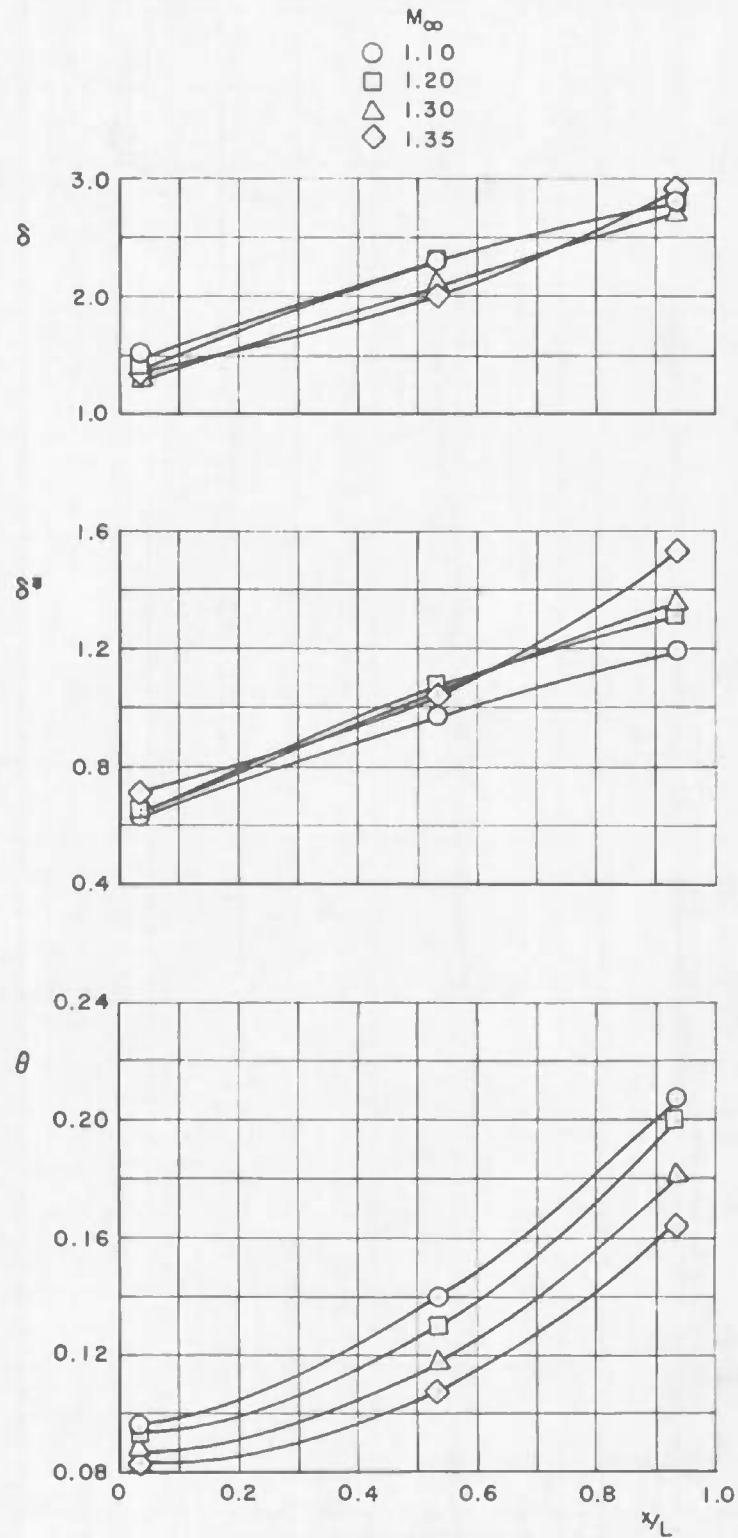

Fig. 11 Variation of Boundary-Layer Characteristics with Rake Position and Mach Number



b. High Reynolds Number Level

Fig. 11 Concluded

$(Re/ft) \times 10^{-6}$

- 1.63
- 3.20

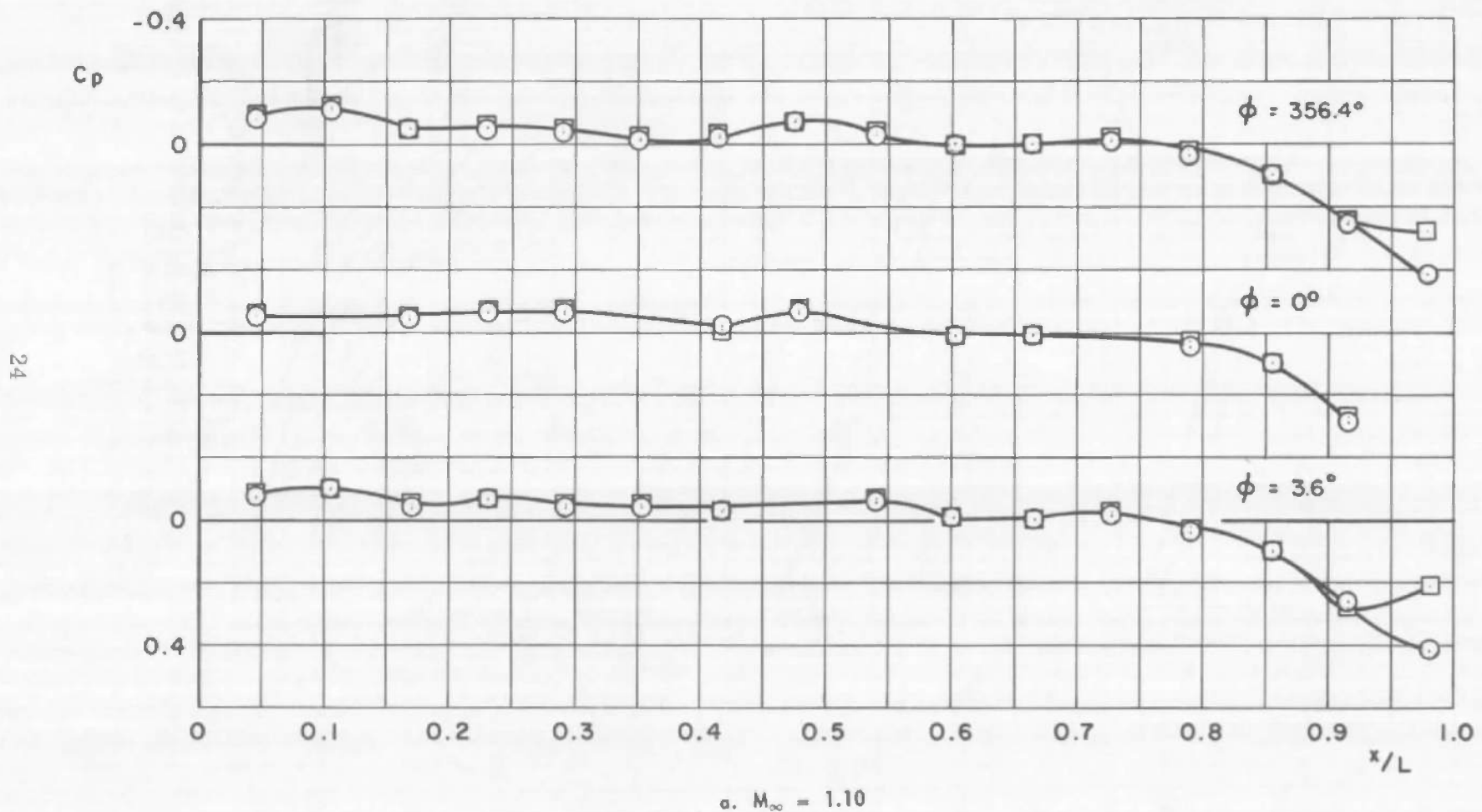

$\alpha. M_\infty = 1.10$

Fig. 12 Variation of Pressure Coefficients along the Pressure Panel

b. $M_\infty = 1.20$

Fig. 12 Continued



$c. M_\infty = 1.30$

Fig. 12 Continued

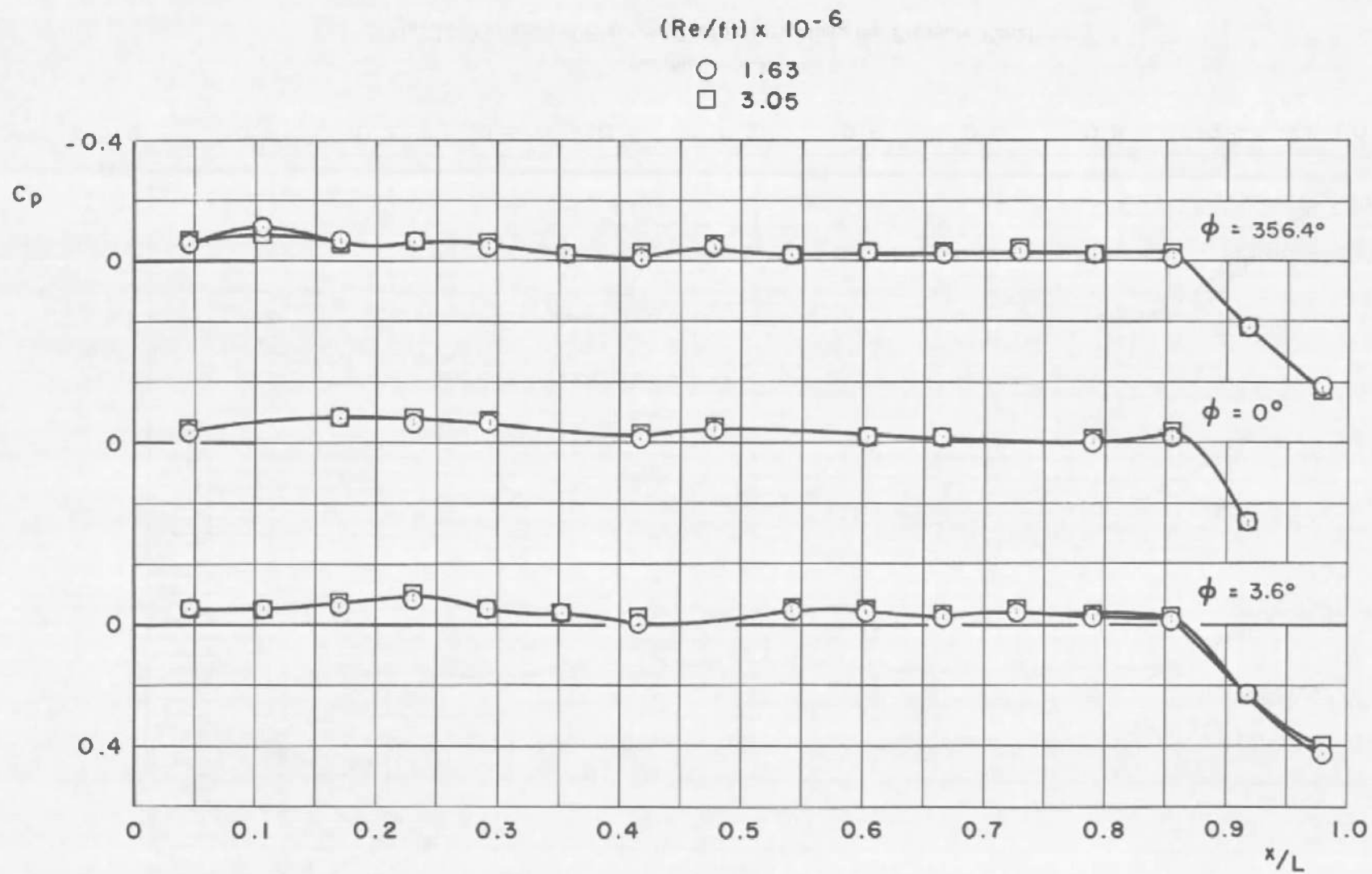
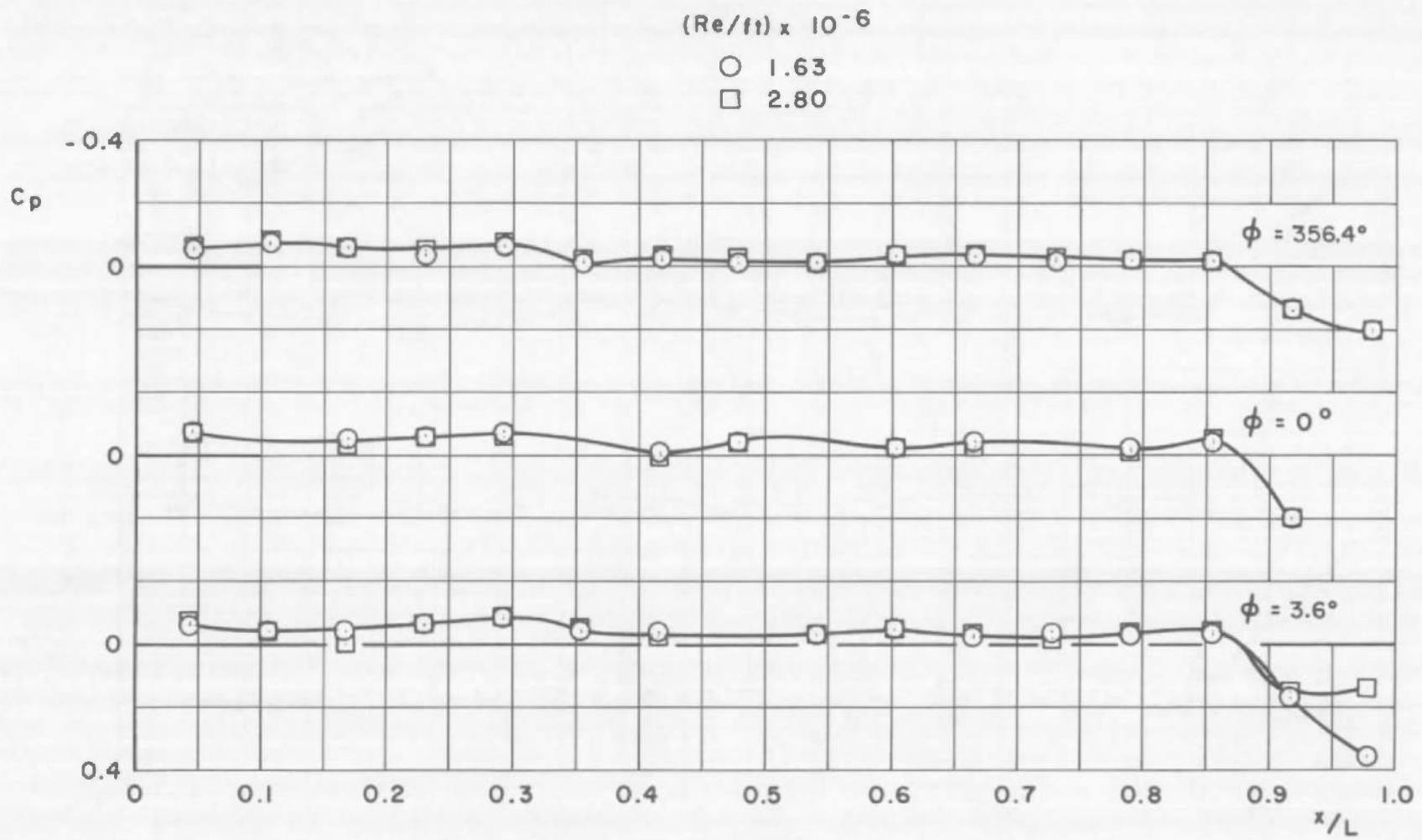
$(Re/ft) \times 10^{-6}$

□ 2.80

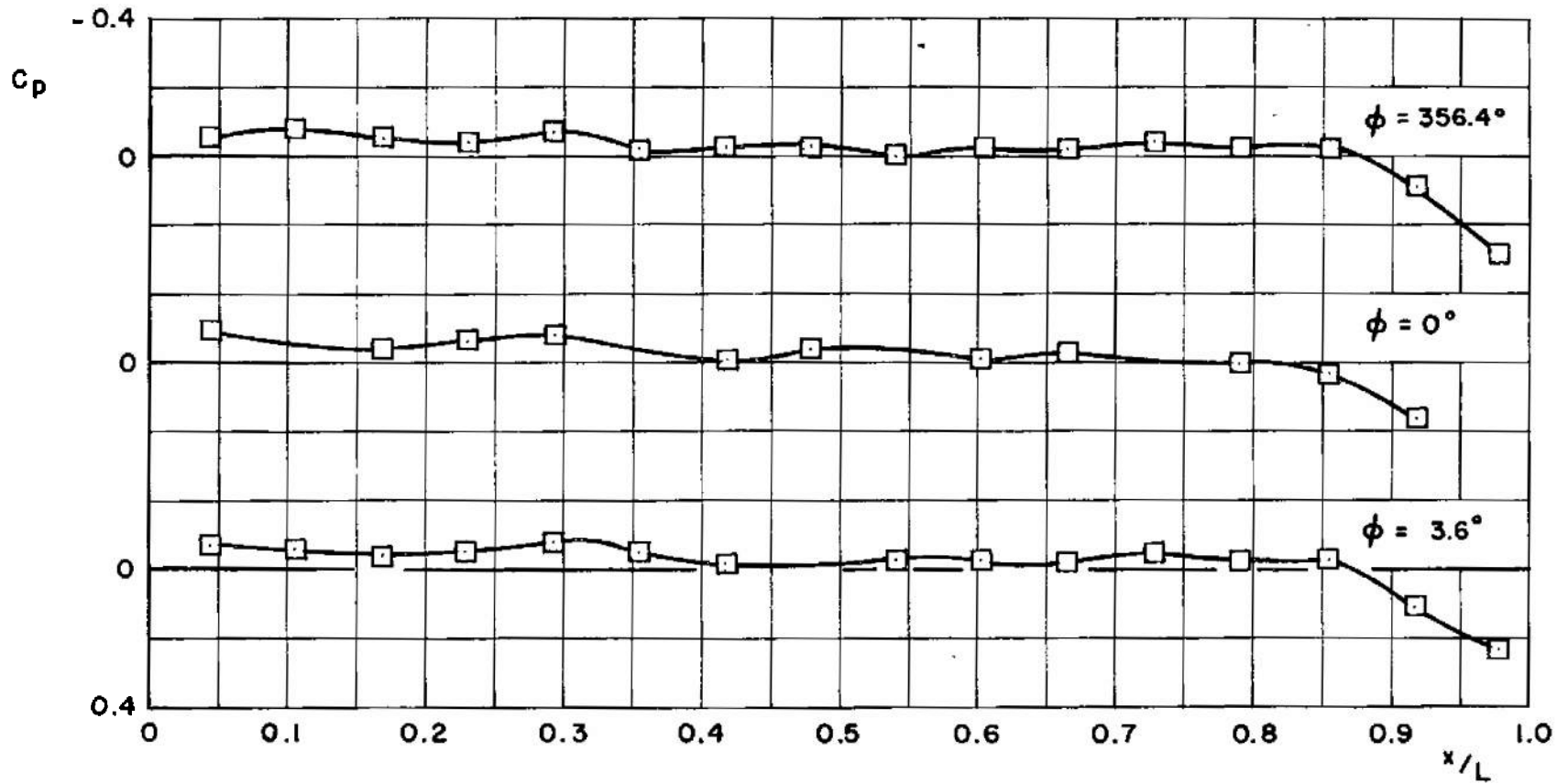

27

d. M_∞ 1.35

Fig. 12 Concluded

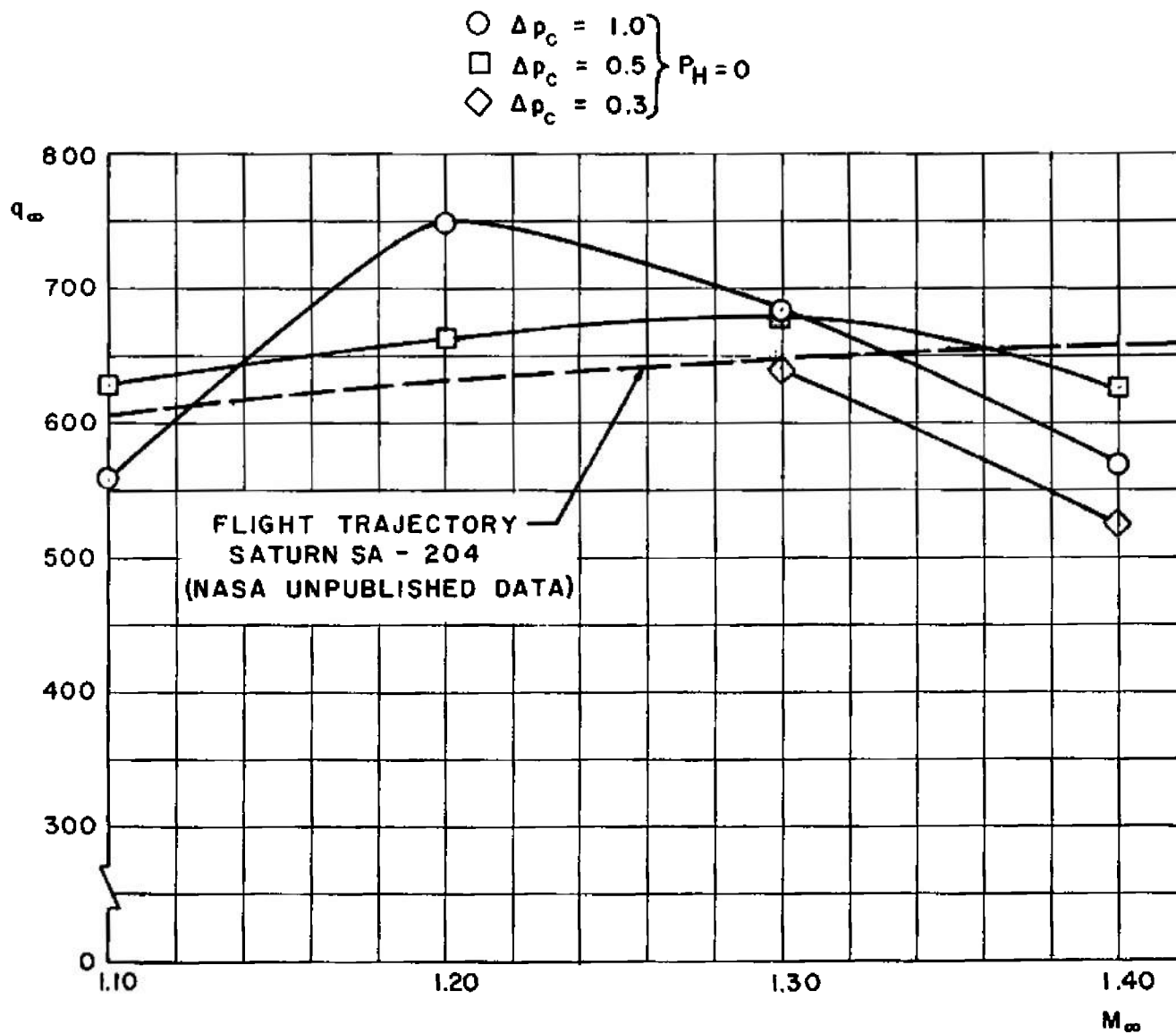
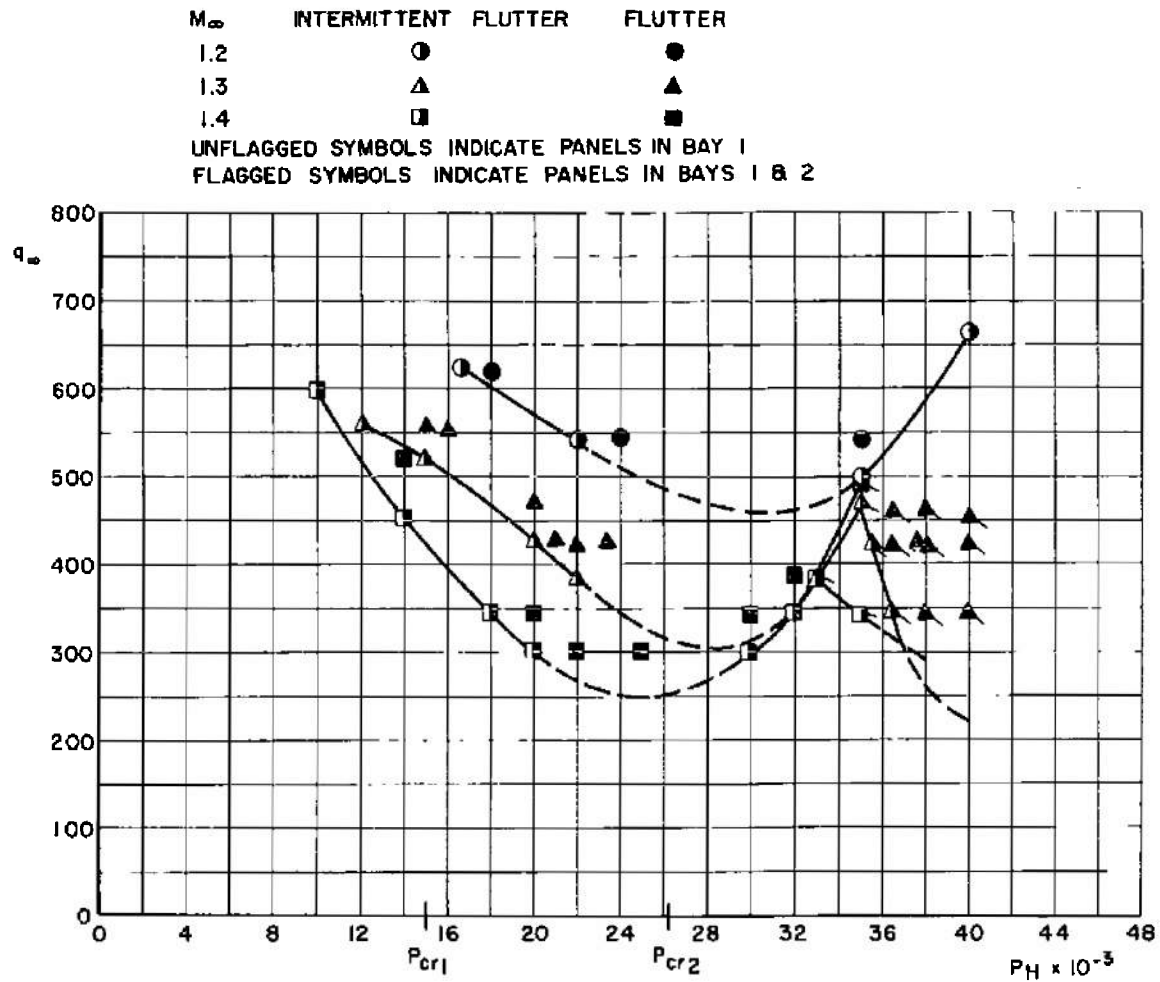

Fig. 13 Variation of Maximum Dynamic Pressure with Mach Number for Flutter Phase



$$a. \Delta p_c = 0.5$$

Fig. 14 Variation of Dynamic Pressure with Axial-Compressive Panel Load

M_∞ INTERMITTENT FLUTTER FLUTTER
 1.3 ▲
 1.4 ■
 UNFLAGGED SYMBOLS INDICATE PANELS IN BAY 1
 FLAGGED SYMBOLS INDICATE PANELS IN BAYS 1 & 2

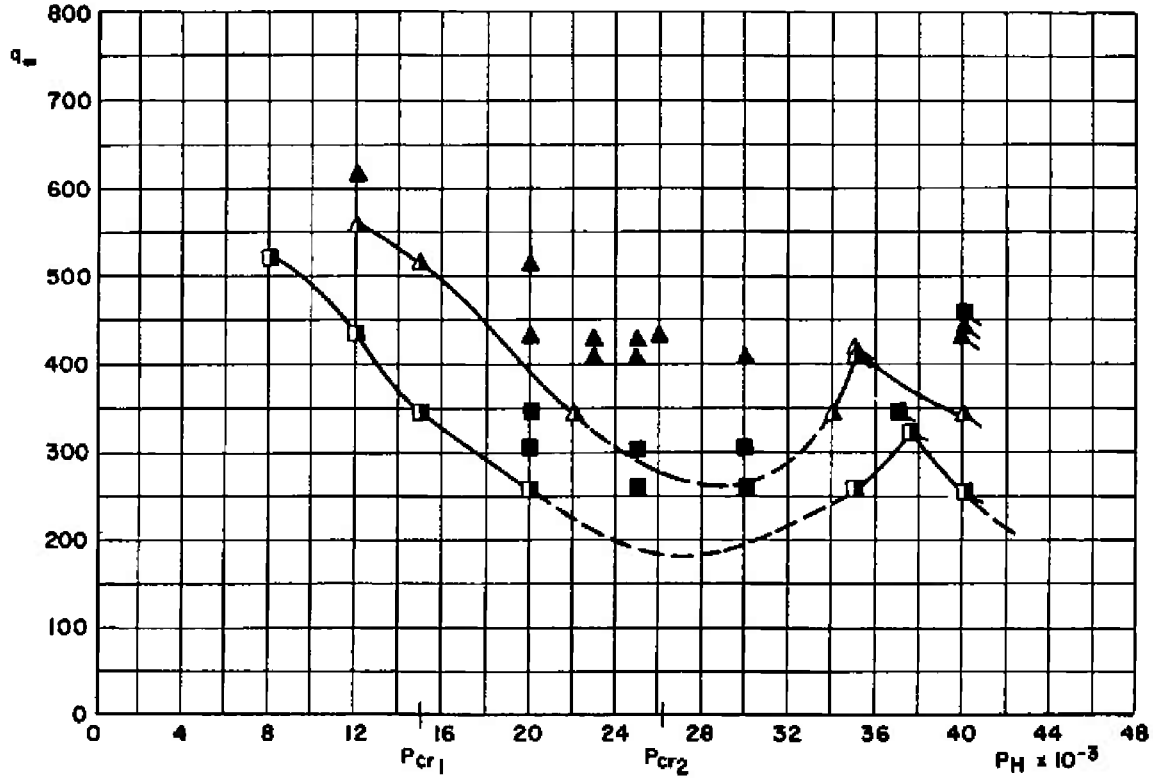

b. $\Delta p_c = 0.3$

Fig. 14 Concluded

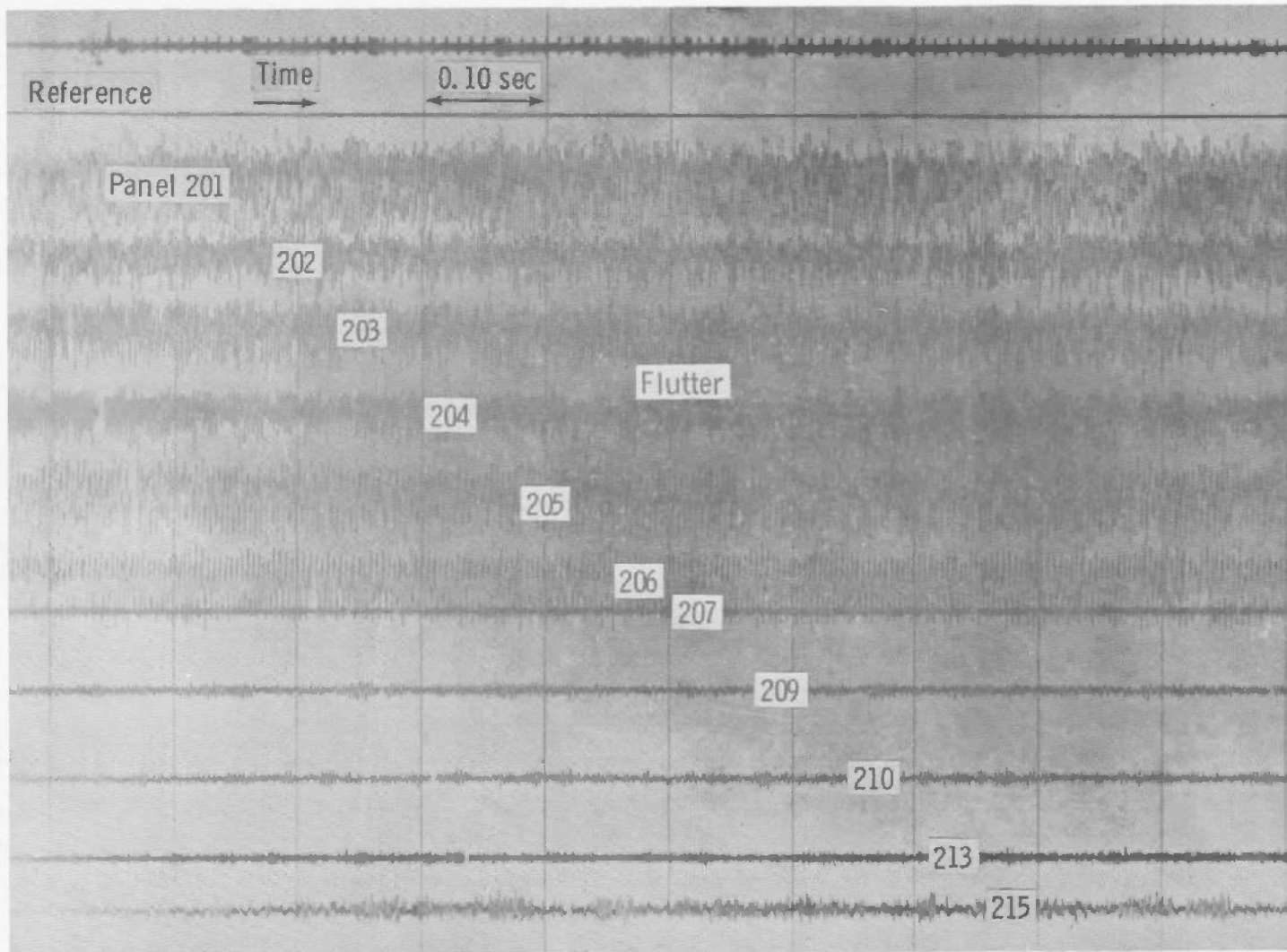

Fig. 15 Oscillograph Trace Showing Panel Flutter

ΔP_c INTERMITTENT FLUTTER FLUTTER
 0.5 ○ ●
 0.3 □ ■
 UNFLAGGED SYMBOLS INDICATE PANELS IN BAY 1
 FLAGGED SYMBOLS INDICATE PANELS IN BAYS 1 & 2

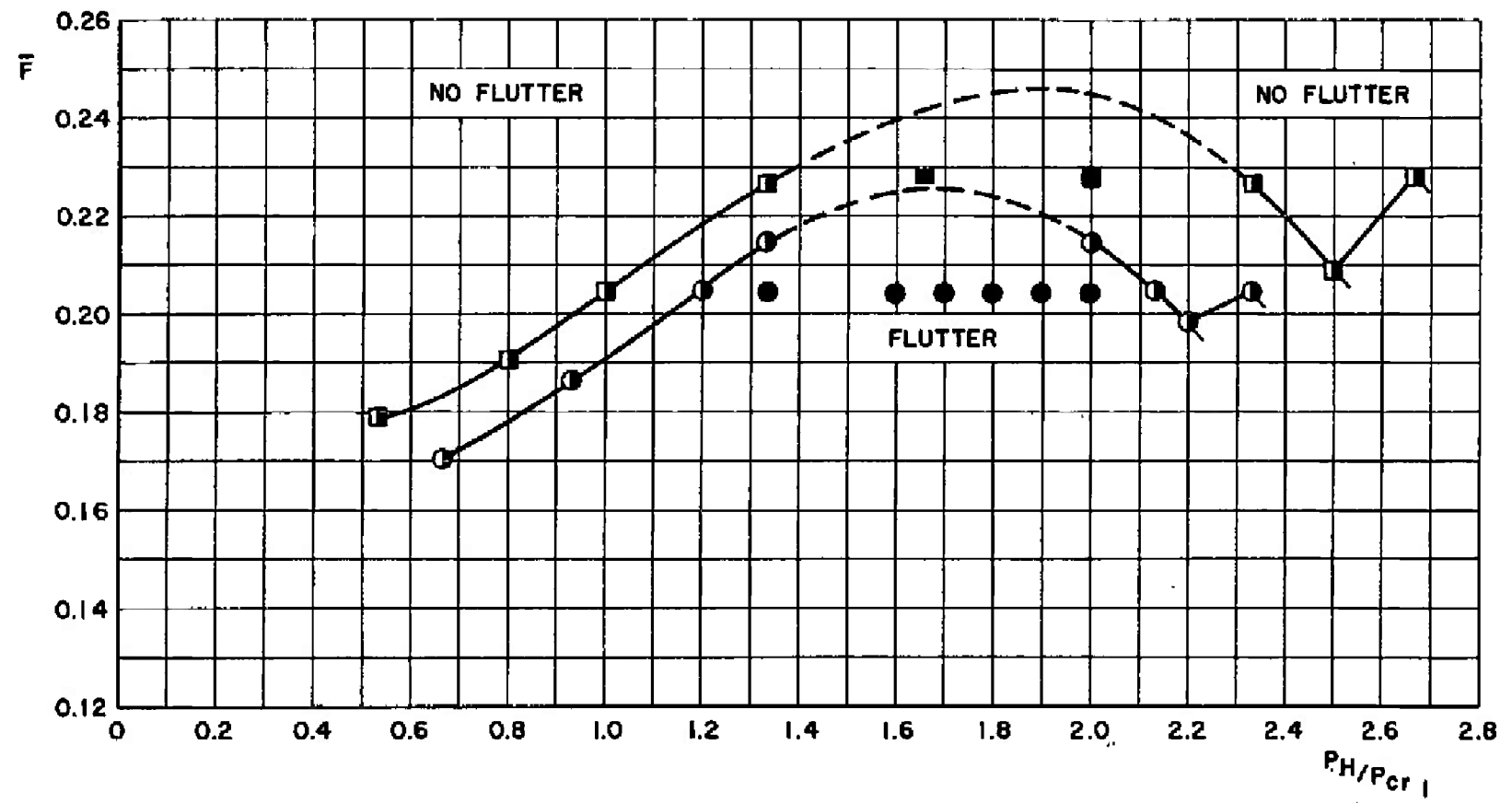

Fig. 16 Variation of the Flutter Parameter with Panel Buckling Load Ratio at $M_{\infty} = 1.40$

TABLE I
SUMMARY OF FLUTTER BOUNDARY RESULTS

| M_∞ | q_∞ , psf | Δp_c , psi | $P_H \times 10^{-3}$, lb | f_{t_1} , cps (panel 202) | \bar{F} |
|------------|--|-----------------------|--|--|--|
| 1.20 ↓ | 625 540 500 665 | 0.50 ↓ | 16.5 22.0 35.0 40.0 | 440 460 490 480 | 0.1475 0.1549 0.1589 0.1445 |
| 1.30 ↓ | 560 520 425 380 380 470 425 345 | 0.50 ↓ | 12.0 15.0 20.0 22.0 33.0 35.0 35.5 36.5 | 500 460 450 480 470 460 490 470 | 0.1649 0.1690 0.1808 0.1877 0.1877 0.1748 0.1808 0.1938 |
| 1.40 ↓ | 600 455 345 300 300 345 380 345 | 0.50 ↓ | 10.0 14.0 18.0 20.0 30.0 32.0 33.0 35.0 | 470 480 490 500 480 480 500 510 | 0.1703 0.1867 0.2048 0.2145 0.2145 0.2048 0.1983 0.2048 |
| 1.30 ↓ | 560 515 340 340 410 340 | 0.30 ↓ | 12.0 15.0 22.0 34.0 35.0 40.0 | 470 470 480 490 490 450 | 0.1649 0.1696 0.1948 0.1948 0.1830 0.1948 |
| 1.40 ↓ | 520 430 345 255 255 325 250 | 0.30 ↓ | 8.0 12.0 15.0 20.0 35.0 37.5 40.0 | 490 520 480 500 510 515 520 | 0.1786 0.1903 0.2048 0.2265 0.2265 0.2089 0.2280 |

DOCUMENT CONTROL DATA - R&D

(Security classification of title, body of abstract and indexing annotation must be entered when the overall report is classified)

| | | | |
|--|--|---|--|
| 1 ORIGINATING ACTIVITY (Corporate author) Arnold Engineering Development Center ARO, Inc., Operating Contractor Arnold Air Force Station, Tennessee | | 2a REPORT SECURITY CLASSIFICATION UNCLASSIFIED | |
| | | 2b GROUP N/A | |
| 3 REPORT TITLE AEROELASTIC STABILITY OF AN ARRAY OF FULL-SCALE PANELS FROM THE SATURN S-IVB STAGE AT TRANSONIC MACH NUMBERS | | | |
| 4 DESCRIPTIVE NOTES (Type of report and inclusive dates) N/A | | | |
| 5 AUTHOR(S) (Last name, first name, initial) Perkins, T. M., ARO, Inc. | | | |
| 6 REPORT DATE February 1967 | 7a TOTAL NO OF PAGES 41 | 7b NO OF REFS 3 | |
| 8a CONTRACT OR GRANT NO. AF 40(600)-1200 | 9a ORIGINATOR'S REPORT NUMBER(S) AEDC-TR-67-9 | | |
| b System 921E | 9b. OTHER REPORT NO(S) (Any other numbers that may be assigned this report) N/A | | |
| 10 AVAILABILITY/LIMITATION NOTICES This document is subject to special export controls and each transmittal to foreign governments or foreign nationals may be made only with prior approval of National Aeronautics and Space Administration, Marshall Space Flight Center.* | | | |
| 11 SUPPLEMENTARY NOTES Available in DDC. | | 12. SPONSORING MILITARY ACTIVITY National Aeronautics and Space Administration, Marshall Space Flight Center, Huntsville, Ala. | |
| 13 ABSTRACT Flutter characteristics of a 30-deg segment of the full-scale Saturn S-IVB stage were obtained at Mach numbers from 1.10 to 1.40 for various combinations of axial-compressive loads and panel differential pressures. Flutter was encountered when sufficient axial load was applied to either partially or completely buckle the panels. No structural failure occurred on any of the panels during this test. Static-pressure and boundary-layer surveys were made on a rigid panel at tunnel conditions comparable to those of the flutter phase. | | | |
| *Huntsville, Ala. | | | |
| This document has been approved for public release | | | |
| This document has been approved for public release its distribution is unlimited. Per A. F. Letter dated 29 May 73 | | | |

| 14 KEY WORDS | LINK A | | LINK B | | LINK C | |
|---|--------|----|--------|----|--------|----|
| | ROLE | WT | ROLE | WT | ROLE | WT |
| liquid propellants rockets SATURN S-IVB transonic flow flutter testing aeroelastic stability testing | | | | | | |

INSTRUCTIONS

1. **ORIGINATING ACTIVITY:** Enter the name and address of the contractor, subcontractor, grantee, Department of Defense activity or other organization (*corporate author*) issuing the report.

2a. **REPORT SECURITY CLASSIFICATION:** Enter the overall security classification of the report. Indicate whether "Restricted Data" is included. Marking is to be in accordance with appropriate security regulations.

2b. **GROUP:** Automatic downgrading is specified in DoD Directive 5200.10 and Armed Forces Industrial Manual. Enter the group number. Also, when applicable, show that optional markings have been used for Group 3 and Group 4 as authorized.

3. **REPORT TITLE:** Enter the complete report title in all capital letters. Titles in all cases should be unclassified. If a meaningful title cannot be selected without classification, show title classification in all capitals in parenthesis immediately following the title.

4. **DESCRIPTIVE NOTES:** If appropriate, enter the type of report, e.g., interim, progress, summary, annual, or final. Give the inclusive dates when a specific reporting period is covered.

5. **AUTHOR(S):** Enter the name(s) of author(s) as shown on or in the report. Enter last name, first name, middle initial. If military, show rank and branch of service. The name of the principal author is an absolute minimum requirement.

6. **REPORT DATE:** Enter the date of the report as day, month, year, or month, year. If more than one date appears on the report, use date of publication.

7a. **TOTAL NUMBER OF PAGES:** The total page count should follow normal pagination procedures, i.e., enter the number of pages containing information.

7b. **NUMBER OF REFERENCES:** Enter the total number of references cited in the report.

8a. **CONTRACT OR GRANT NUMBER:** If appropriate, enter the applicable number of the contract or grant under which the report was written.

8b, 8c, & 8d. **PROJECT NUMBER:** Enter the appropriate military department identification, such as project number, subproject number, system numbers, task number, etc.

9a. **ORIGINATOR'S REPORT NUMBER(S):** Enter the official report number by which the document will be identified and controlled by the originating activity. This number must be unique to this report.

9b. **OTHER REPORT NUMBER(S):** If the report has been assigned any other report numbers (either by the originator or by the sponsor), also enter this number(s).

10. **AVAILABILITY/LIMITATION NOTICES:** Enter any limitations on further dissemination of the report, other than those

imposed by security classification, using standard statements such as:

- (1) "Qualified requesters may obtain copies of this report from DDC."
- (2) "Foreign announcement and dissemination of this report by DDC is not authorized."
- (3) "U. S. Government agencies may obtain copies of this report directly from DDC. Other qualified DDC users shall request through _____."
- (4) "U. S. military agencies may obtain copies of this report directly from DDC. Other qualified users shall request through _____."
- (5) "All distribution of this report is controlled. Qualified DDC users shall request through _____."

If the report has been furnished to the Office of Technical Services, Department of Commerce, for sale to the public, indicate this fact and enter the price, if known.

11. **SUPPLEMENTARY NOTES:** Use for additional explanatory notes.

12. **SPONSORING MILITARY ACTIVITY:** Enter the name of the departmental project office or laboratory sponsoring (*paying for*) the research and development. Include address.

13. **ABSTRACT:** Enter an abstract giving a brief and factual summary of the document indicative of the report, even though it may also appear elsewhere in the body of the technical report. If additional space is required, a continuation sheet shall be attached.

It is highly desirable that the abstract of classified reports be unclassified. Each paragraph of the abstract shall end with an indication of the military security classification of the information in the paragraph, represented as (TS), (S), (C), or (U).

There is no limitation on the length of the abstract. However, the suggested length is from 150 to 225 words.

14. **KEY WORDS:** Key words are technically meaningful terms or short phrases that characterize a report and may be used as index entries for cataloging the report. Key words must be selected so that no security classification is required. Identifiers, such as equipment model designation, trade name, military project code name, geographic location, may be used as key words but will be followed by an indication of technical context. The assignment of links, rules, and weights is optional.