

UNCLASSIFIED

AD NUMBER

AD810372

LIMITATION CHANGES

TO:

Approved for public release; distribution is unlimited.

FROM:

Distribution: Further dissemination only as directed by Army Mobility Command, Attn: Project Manager, AMCPM-GP-TLV. Warren, MI 48090., MAR 1967, or higher DoD authority.

AUTHORITY

CSS memo dtd 22 Mar 2013

THIS PAGE IS UNCLASSIFIED

AD

RDT&E Project No. Not Available
USATECOM Project No. 1-6-4030-12
Report No. DPS-2309



FINAL REPORT ON
PRODUCT IMPROVEMENT TEST
OF
TRUCK, UTILITY, 1/4-TON, 4X4, M151, MODIFIED
WITH SOLID REAR AXLE
BY
C. M. BRYZEK, JR.
MARCH 1967

ABERDEEN PROVING GROUND
ABERDEEN PROVING GROUND, MARYLAND

DDC AVAILABILITY NOTICE

This document may be further distributed by any holder only with specific prior approval of the Project Manager,

ATTN: AMCPM-GP-TLV.

REPRODUCTION LIMITATIONS

Reproduction of this document in whole or in part is prohibited except with the permission of the Project Manager, ATTN: AMCPM-GP-TLV.

DDC is authorized to reproduce this document for United States Government purposes.

DISPOSITION INSTRUCTIONS

Destroy this report in accordance with AR 380-5 when no longer needed. Do not return it to the originator.

DISCLAIMER

The findings in this report are not to be construed as an official Department of the Army position, unless so designated by other authorized documents issued and approved by the Department of the Army.

RDT&E PROJECT NO. NOT AVAILABLE

USATECOM PROJECT NO. 1-6-4030-12

PRODUCT IMPROVEMENT TEST OF
TRUCK, UTILITY, 1/4-TON, 4X4, M151, MODIFIED
WITH SOLID REAR AXLE

FINAL REPORT

BY

C. M. BRYZEK, JR.

MARCH 1967

ABERDEEN PROVING GROUND
ABERDEEN PROVING GROUND, MARYLAND
21005

iii

TABLE OF CONTENTS

	<u>PAGE</u>
ABSTRACT -----	vii
FOREWORD -----	vii
FRONTISPIECE -----	viii
 <u>SECTION 1. INTRODUCTION</u> 	
1.1 BACKGROUND -----	1
1.2 DESCRIPTION OF MATERIEL -----	1
1.3 TEST OBJECTIVES -----	4
1.4 SUMMARY OF RESULTS -----	4
1.5 CONCLUSIONS -----	4
1.6 RECOMMENDATIONS -----	5
 <u>SECTION 2. DETAILS OF TEST</u> 	
2.1 INTRODUCTION -----	6
2.2 INITIAL INSPECTION AND LUBRICATION -----	6
2.3 PRELIMINARY OPERATION -----	7
2.4 WEIGHT DISTRIBUTIONS -----	7
2.5 CENTER OF GRAVITY -----	8
2.6 PHYSICAL DIMENSIONS -----	9
2.7 TURNING RADII -----	9
2.8 GRADEABILITY AND SIDE-SLOPE PERFORMANCE -----	10
2.9 BRAKING -----	11
2.10 STANDARD OBSTACLES -----	12
2.11 DURABILITY -----	12
 <u>SECTION 3. APPENDICES</u> 	
EP SUMMARY SHEETS -----	I-1
PHOTOGRAPHS -----	II-1
CORRESPONDENCE -----	III-1
DISTRIBUTION LIST -----	IV-1

ABSTRACT

A product improvement test was conducted on a truck, utility, 1/4-ton, 4x4, M151, modified with solid rear axle, at Aberdeen Proving Ground (APG) from 12 April to 30 December 1966. The purpose of this test was to determine the engineering performance and durability characteristics of the vehicle. The vehicle was subjected to limited engineering performance tests and a 20,000-mile durability test. It was concluded that the M151 modified with solid rear axle was unsatisfactory due to lack of durability of a majority of the modified components.

FOREWORD

Development and Proof Services was responsible for conducting the test and preparing the test report.



18001-1923-ANC-66-/82: Frontispiece.

ABERDEEN PROVING GROUND
ABERDEEN PROVING GROUND, MARYLAND 21005

USATECOM PROJECT NO. 1-6-4030-12

FINAL REPORT ON PRODUCT IMPROVEMENT TEST OF
TRUCK, UTILITY, 1/4-TON, 4X4, M151,
MODIFIED WITH SOLID REAR AXLE

12 APRIL THROUGH 30 DECEMBER 1966

SECTION 1. INTRODUCTION

1.1 BACKGROUND

Production of the truck, utility, 1/4-ton, 4x4, M151, began in 1960. Since introduction of the vehicle, several accidents have occurred involving turnover of the vehicle and fatalities.

In an effort to reduce the accident rate, an M151 was modified to incorporate a solid rear axle and thus provide better handling characteristics by eliminating oversteer tendencies. This modification would also result in a reduced cost.

One modified M151 was sent to Aberdeen Proving Ground, Maryland to undergo engineering performance and endurance tests.

1.2 DESCRIPTION OF MATERIEL

The test vehicle was a standard truck, utility, 1/4-ton, 4x4, M151, modified in the following areas:

- a. Body - Frame. The unitized body - frame structure was modified in the area behind the driver's and assistant driver's seats. The outer frame rails were increased in strength and simplified in construction. The rear suspension leaf-spring attaching brackets were incorporated into the unitized structure by welding them to the redesigned outer rails. The rear cross member of the frame was redesigned and relocated to provide clearance for the new rear axle assembly and attachment of the rear shock absorbers.

- b. Rear Axle. The rear differential carrier and independent wheel drive shafts were replaced by a solid axle assembly (ref Figure 1.2-1).

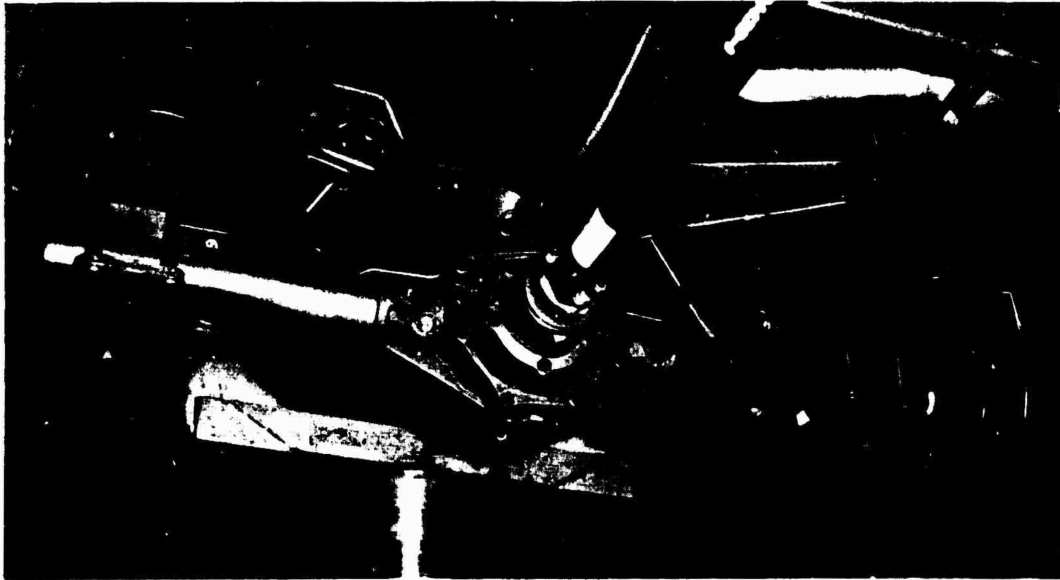

Figure 1.2-1: Solid Rear Axle Installation.

- c. Front Differential Carrier. Since it was desirable to maintain the front independent suspension, an independent differential carrier assembly was incorporated to utilize the maximum number of interchangeable parts with the new rear differential. The differential assembly and pinion-shaft bearing housing are interchangeable from front to rear differential carrier assemblies.
- d. Rear Suspension. The rear suspension coil springs were replaced by 4-leaf half-elliptic springs. Each spring assembly is symmetrical and held together by a center bolt and two clips, retaining three of the four leaves. The springs are attached to the outer frame rail brackets by pins at the front and shackles at the rear.

- e. Rear Shock Absorbers. New rear shock absorbers having approximately double the resistance in rebound of standard units to compensate for the additional unsprung weight were installed. They are mounted at their upper ends by bolts inside the redesigned rear frame cross member and at their lower ends to the back side of solid axle tubes (Figure 1.2-1).
- f. Front Suspension. Coil springs with a wire diameter of 0.647 inch to 0.653 inch replaced the standard spring having a wire diameter of 0.622 inch to 0.628 inch. Thus, the new springs had a higher spring rate.
- g. Front Shock Absorbers. New front shock absorbers using cross pin lower attachment instead of a separate mounting bracket and new designed insulators and washers at their top mountings were installed. Flanged nuts were utilized on the upper control arms to cross member attaching bolts.
- h. Transmission - Transfer Assembly. The transfer incorporates a fixed output flange at its rear output shaft (Figure 1.2-2). This flange prevents axial movement of the transfer output gear and bearings on the shaft when the flange is locked to the shaft by a locknut. Rearward movement of the shaft assembly is prevented by a combination bearing retainer and seal housing that bears against the rear bearing outer race. Forward movement is restricted by a snap ring on the rear bearing outer race that acts against the shoulder of the transfer case bore.



Figure 1.2-2: Transfer Case Rear Output.

- i. Propeller Shafts. The front propeller shaft is similar to the standard shaft, but is one inch shorter. The new rear propeller shaft incorporates a splined slip-joint assembly to provide for the variation in shaft length required by the rear suspension motion (Figure 1.2-2).
- j. Exhaust System. The configuration of the tail pipe between the muffler and the exhaust extension at the rear of the vehicle was revised to allow clearance for the rear axle and suspension components.
- k. Brake System. One flexible hose to the rear axle is used in place of the two hoses on a standard vehicle. The hose connects to a tee fitting attached to the top of the differential carrier. Steel tubes lead from the tee fitting to the rear wheel cylinders (Figure 1.2-1)

1.3 TEST OBJECTIVES

To determine the engineering performance and durability characteristics of a truck, utility, 1/4-ton, 4x4, M151, modified with a solid rear axle.

1.4 SUMMARY OF RESULTS

The outer longitudinal rails of the vehicle frame deformed in the areas of the rear axle bump stops during 9038 durability test miles. At this time reinforcements were added to the rails; however, severe deformation was again encountered during the remaining 11,093 test miles.

The lower durometer rear-axle bump stops installed during the test to reduce the harsh ride failed after 5569 and again at 2003 test miles.

After shallow-water fording of the vehicle, water was found in the rear wheel-bearing cavities.

The snap-ring groove of the the rear-axle pinion-gear shaft pilot failed.

During the final inspection, the endplay of the transfer-case rear-output shaft was found to be excessive at 0.113 inch.

1.5 CONCLUSIONS

It was concluded that the truck, utility, 1/4-ton, 4x4, M151, modified with a solid rear axle, was unsatisfactory because of the following defects:

- a. Frame distortion at the rear axle bump stops (ref par. 2.11.3.7).
- b. Failure of the rear axle bump stops (ref par. 2.11.3.8).
- c. Harsher ride than standard M151A1 (ref par. 2.11.3.8).
- d. Lubricant being forced out of the rear-axle breather assembly (ref par. 2.11.3.5).
- e. Inadequate sealing between the rear-axle brake-backing plates and the axle tubes (ref par. 2.11.3.6).
- f. Failure of the rear-axle pinion-gear shaft pilot bearing (ref par. 2.11.3.5).
- g. Difficulty of replacing rear-axle wheel bearing seals and repacking bearings (ref par. 2.11.3.5).
- h. Excessive endplay of the transfer-case rear-output shaft (ref par. 2.11.3.2).
- i. Distortion of the front propeller shaft (ref par. 2.11.3.3).

1.6 RECOMMENDATIONS

Not applicable.

SECTION 2. DETAILS OF TEST

2.1 INTRODUCTION

The test vehicle (USA Reg No. 2J7110) arrived at Aberdeen Proving Ground on 12 April 1966.

After 9038 miles of durability testing, the test program was suspended for 52 days while the vehicle was returned to the production engineering contractor (PEC) for modification.

Drawbar pull and full-load cooling tests were deleted from the test program in accordance with AMCPM-GP, Teletype 12-4855 (Appendix III).

Upon completion of the test program the vehicle was returned to the PEC.

2.2 INITIAL INSPECTION AND LUBRICATION

2.2.1 Objectives

To assure that the test vehicle is in good mechanical condition, properly serviced, and ready for test.

2.2.2 Method

The vehicle was given an initial inspection and lubrication as prescribed in the technical publications for the vehicle.

2.2.3 Results

The vehicle was in good mechanical condition and only minor adjustments were made during the initial inspection and lubrication.

2.2.4 Analysis

Not applicable.

2.3 PRELIMINARY OPERATION

2.3.1 Objective

To operate the vehicle without payload for a prescribed number of miles to insure the proper seating of mating parts.

2.3.2 Method

The vehicle was operated on the paved course for a total of 500 miles as follows:

- a. Two hundred miles at speeds up to 30 mph.
- b. Three hundred miles at speeds up to 55 mph.

2.3.3 Results

Preliminary operation was completed without incident.

2.3.4 Analysis

Not applicable.

2.4 WEIGHT DISTRIBUTION

2.4.1 Objective

To determine the weight distribution of the vehicle at curb weight, with cross-country payload, and with highway payload.

2.4.2 Method

The weight distribution of the vehicle was obtained by the use of loadometers at each wheel.

2.4.3 Results

The vehicle weight distributions are shown in Table 2.4-I.

Table 2.4-I. Weight Distributions

<u>Wheel Location</u>	<u>Curb Weight, lb</u>	<u>With Cross-Country Payload^a, lb</u>	<u>With Highway Payload^b, lb</u>
Left front	670	750	740
Right front	670	740	770
Left rear	540	880	1050
Right rear	530	880	1060
Total	2410	3250	3620

^aRated cross-country payload including crew - 800 pounds.

^bRated highway payload including crew - 1200 pounds.

2.4.4 Analysis

Not applicable.

2.5 CENTER OF GRAVITY

2.5.1 Objective

To determine the center of gravity of the vehicle at curb weight.

2.5.2 Method

The center of gravity in three planes was determined by the suspension method.

2.5.3 Results

The center of gravity of the vehicle at curb weight was located 46-1/2 inches forward and 6 inches above the centerline of the rear wheel. The lateral location was on the vehicle centerline.

2.5.4 Analysis

Not applicable.

2.6 PHYSICAL DIMENSIONS

2.6.1 Objectives

To determine the minimum ground clearance and angles of approach and departure of the vehicle at curb weight, with cross-country payload, and with highway payload.

2.6.2 Method

The minimum ground clearance and angles of approach and departure were obtained by use of a measuring scale and protractor.

2.6.3 Results

The minimum ground clearances and angles of approach and departure of the vehicle are shown in Table 2.6-I.

Table 2.6-I. Physical Dimensions

<u>Dimension</u>	<u>Curb Weight</u>	<u>With Cross-Country Payload</u>	<u>With Highway Payload</u>
Minimum ground clearance	9-5/8 in.	9 in.	9 in.
Angle of approach	63 deg	62 deg	62 deg
Angle of departure	47 deg	43 deg	41 deg

2.6.4 Analysis

At the time of receipt, the vehicle at curb weight had approximately a 3-degree nose-down trim, which was distinguishable from a distance and which made the vehicle conspicuous in a group of standard M151A1 trucks.

2.7 TURNING RADII

2.7.1 Objective

To determine the minimum turning radii of the vehicle to the right and left.

2.7.2 Method

The minimum turning radii of the vehicle were obtained by measuring the circumferences of the circles described at the centerline of the outer front tire while making full 360-degree left and right turns.

2.7.3 Results

Minimum turning radii were 17.8 feet for both full right and left turns.

2.7.4 Analysis

Not applicable.

2.8 GRADEABILITY AND SIDE-SLOPE PERFORMANCE

2.8.1 Objectives

To determine maximum sustained speeds of the vehicle on longitudinal slopes of 5 through 60 per cent and operational characteristics of the vehicle on a 40 per cent side slope.

2.8.2 Method

The vehicle was operated on the longitudinal slopes at full throttle in the gear that provided maximum sustained speed. Road speed was obtained with a calibrated fifth wheel. Operational characteristics of the vehicle on a 40 per cent side slope were observed.

2.8.3 Results

Maximum sustained speeds of the vehicle on the longitudinal slopes are shown in Table 2.8-I.

Table 2.8-I. Longitudinal Slope Performance

Slope, %	Road Speed, mph	Gear
5	^a 40	3rd, 2-wheel drive
10	39	3rd, 2-wheel drive
15	36	2nd, 4-wheel drive
20	23	2nd, 4-wheel drive
30	15	2nd, 4-wheel drive
40	12	1st, 4-wheel drive
50	10	1st, 4-wheel drive
60	8.9	1st, 4-wheel drive

^aNot a sustained speed.

Operation of the vehicle on a 40 per cent side slope was satisfactory with respect to engine idle, restart, and stability. The fuel tank filler cap leaked when downgrade.

2.8.4 Analysis

Not applicable.

2.9 BRAKING

2.9.1 Objectives

To determine the maximum longitudinal slope on which the parking brake or service brakes would independently hold and control the vehicle in both ascending and descending attitudes.

To determine the distance required to stop the vehicle from a speed of 20 mph on a dry, hard, level road free from loose material.

2.9.2 Method

Vehicle stopping distances were determined by means of a fifth wheel and pousometer with transmission in neutral and maximum pedal effort braking from 20 mph.

2.9.3 Results

The parking brake and service brakes held the vehicle stationary in both ascending and descending attitudes on a 60 per cent longitudinal slope.

The average stopping distance of the vehicle from a speed of 20 mph was 20 feet.

2.9.4 Analysis

Vehicle braking was adequate.

2.10 STANDARD OBSTACLES

2.10.1 Objective

To determine if the vehicle could be operated over various standard obstacles without interferences between vehicle components or the vehicle and obstacle profile.

2.10.2 Method

The vehicle was visually observed while operating over the frame twister and through the simulated ditch.

2.10.3 Results

The vehicle operated satisfactorily over the frame twister and through the simulated ditch.

2.10.4 Analysis

Not applicable.

2.11 DURABILITY

2.11.1 Objective

To determine the durability characteristics of the vehicle.

2.11.2 Method

The vehicle was operated for a total of 20,000 miles by completing the following cycle four times.

Durability Cycle

<u>Course</u>	<u>Mileage</u>
Paved highway	1050
Belgian block	150
Level cross-country (Perryman No. 1)	1900
Hilly cross-country (Churchville)	1900
Total	5000

All operations were conducted with the following rated loads.

- a. Cross-country. Eight hundred pounds including crew.
- b. Highway. Twelve hundred pounds including crew.

Fifty per cent of all operations were with the following rated towed loads.

- a. Cross-country. Fifteen hundred pounds.
- b. Highway. Two thousand pounds.

The vehicle was shallow-water (21 inches) forded prior to starting operation, after 12,000 miles and at the completion of 20,000 miles.

2.11.3 Results

A summary of vehicle operation is shown in Table 2.11-I.

Table 2.11-I. Summary of Operations

<u>Course</u>	<u>Mileage</u>		<u>Total</u>
	<u>Without Towed Load</u>	<u>With Towed Load</u>	
Paved highway	2179	2106	4285
Belgian block	300	301	601
Level cross-country (Perryman No. 1)	3803	3800	7603
Hilly cross-country (Churchville)	3801	3794	7595
Total	10083	10001	20084

The over-all average fuel consumption was 11.0 mpg and average oil consumption was 3080 mpq.

A summary of incidents encountered during the test is contained in Appendix I. The most significant of these incidents are discussed according to functional group.

2.11.3.1 Group 04, Exhaust System. During vehicle operation, the cross-over section of the forward exhaust pipe was rubbing the front propeller shaft, resulting in a hole in the pipe. Upon replacement of the pipe, the static clearance between it and the shaft was 5/16 inch and, although there may have been contact, no holes developed in the pipe during the remaining 13,744 miles of operation.

2.11.3.2 Groups 07 and 08, Transmission - Transfer Assembly. After completion of the durability test, the endplay of the transfer rear output shaft was excessive at 0.113 inch.

2.11.3.3 Group 09, Propeller Shafts. After 7228 test miles, the rear propeller shaft was bent approximately 1/2 inch at the center. During modification by the PEC after 9038 test miles, a newly designed shaft with increased U-joint angularity and tube diameter was incorporated. Also, a rubber windup bumper was installed as shown in Figure 2.11-1 to prevent excessive windup of the rear axle.



Figure 2.11-1: Rear Axle Windup Stop.

During the final inspection after completion of the durability test, it was discovered that the front propeller shaft was slightly deformed (axis offset).

2.11.3.4 Group 10 Front Axle. A 1/2-inch crack developed in the left front lower control arm (Figure 2.11-2). The increased rate of the front springs could have contributed to this crack.



Figure 2.11-2: Crack in Left Front Lower Control Arm.

The front suspension cross member contained cracks at the mounting perch for the left lower control arm (Figure 2.11-3), in the area where the left rear bolt attaches it to the left longitudinal frame rail (Figure 2.11-4) and near both upper spring seats.



Figure 2.11-3: Crack in Front Suspension Cross Member at Front Mounting Perch for Left Lower Control Arm.



Figure 2.11-4: Crack in Front Suspension Cross Member in Area of Left Rear Attaching Bolt.

2.11.3.5 Group 11, Rear Axle. During operation, the rear differential lost lubricant through the differential carrier vent, at the rivets which attach the brake tube bracket to the carrier. After replacement of the vent at 6004 test miles, loss of lubricant through the vent was reduced. However, after 400 miles of operation, it was found that gear oil had been forced past the axle shaft inner seals and was contaminating the lubricant of the rear wheel bearings.

In accordance with directions from ANCPM-GP-TI (Appendix III), rear wheel bearings were not repacked at the normal 12,000 mile interval. However, after 17,801 test miles, rear-differential lubricant was leaking past the left and right rear-axle seals and wheel-bearing outer seals into the brake cavities. Replacement of the rear-axle wheel-bearing outer seals or repacking the bearings required an excessive amount of maintenance time, since the retaining collar must be broken and then the bearing must be pressed off the shaft (Figure 2.11-5). Extreme care must be exercised when pressing the bearing off and on the shaft to prevent bearing damage.

Lubricant leakage was excessive past the pinion-shaft seal after 17,801 test miles. Prior to removal of the pinion-shaft bearings and seal, the shaft endplay was measured and found to be 0.017 inch. Upon replacement of the seal, shaft endplay was adjusted to 0.000 inch.

Examination of the rear axle assembly after completion of the durability test disclosed that the snap-ring groove in the pinion shaft pilot bearing was broken off around the circumference of the bearing (Figure 2.11-6).

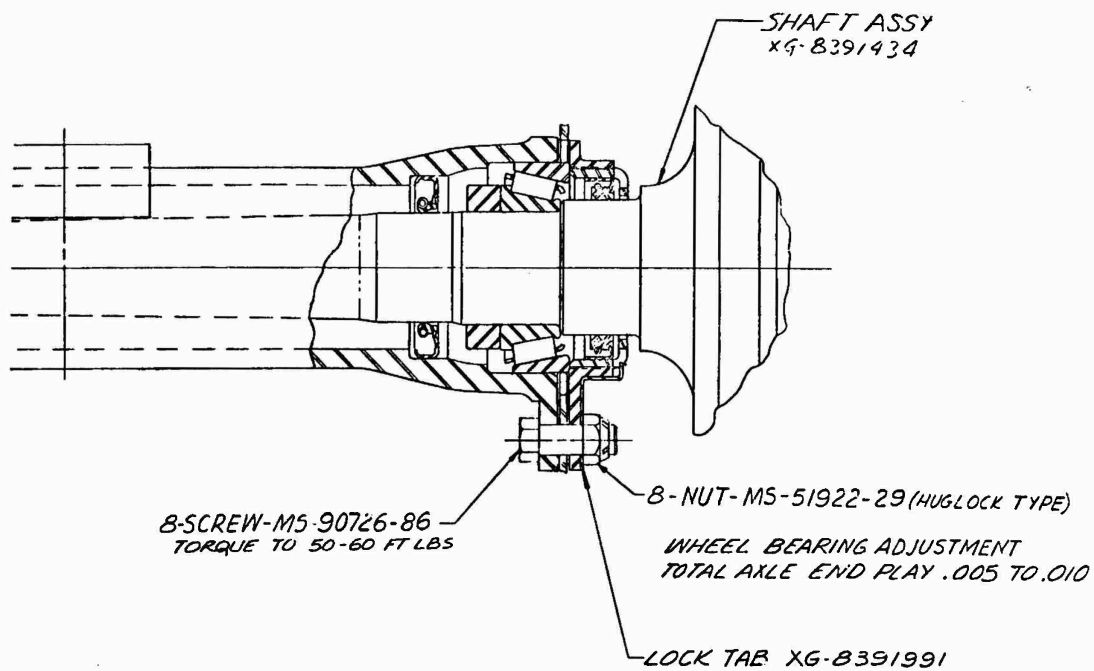

Figure 2.11-5: Axle-Shaft Assembly.

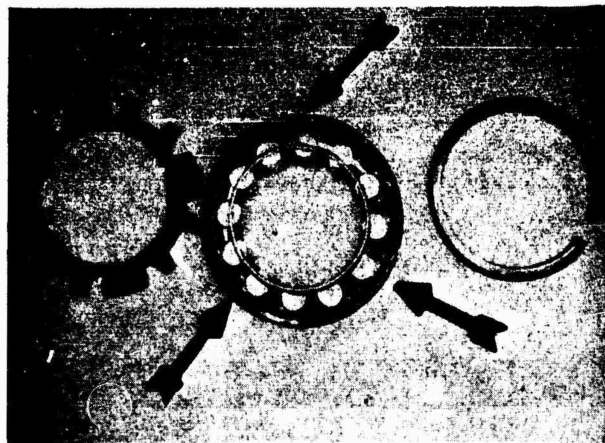

Figure 2.11-6: Snap-Ring Groove Broken Off Pinion-Shaft Pilot Bearing.

The roller ends of the pinion-shaft tapered roller bearing adjacent to the gear were excessively worn although the shaft endplay had not changed from the 0.000 inch adjustment made after 17,801 test miles. The ring gear to pinion gear backlash was 0.016 inch. Gear oil was leaking past the left and right axle-shaft seals and wheel-bearing outer seals which had been replaced at 17,801 test miles.

2.11.3.6 Group 12, Brakes. The gaskets used between the rear wheel brake-backing plates and the axle tubes were inadequate because the surface between the plate and tube is insufficient in the area of the wheel cylinder.

The brakes became very ineffective when gear oil entered the brake cavities.

2.11.3.7 Groups 15 and 18, Frame and Body. The outer longitudinal frame rails became excessively deformed (dented) at the areas where the rear-axle bump stops contact. The test was suspended and the vehicle was returned to the PEC for modification. The modification consisted of straightening the deformed frame rails and adding a reinforcement (Figure 2.11-7) inside each rail.



Figure 2.11-7: Reinforcement of Outer Longitudinal Frame Rail.

During final inspection after completion of the durability test, it was found that the frame rails were again excessively deformed in the areas of the rear-axle bump stops and a crack had developed in the right rail (Figures 2.11-8 and 2.11-9). The inner vertical panel of the right rear wheel well was buckled (Figure 2.11.10), thus indicating that the frame rail reinforcements were unsuccessful in preventing distortion.



Figure 2.11-8: Deformed Left Frame Rail in Contact Area of Rear-Axle Bump Stop.

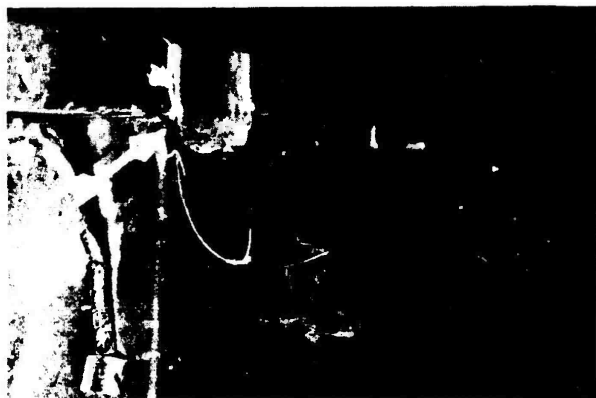

Figure 2.11-9: Deformed Right Frame Rail in Contact Area of Rear-Axle Bump Stop.

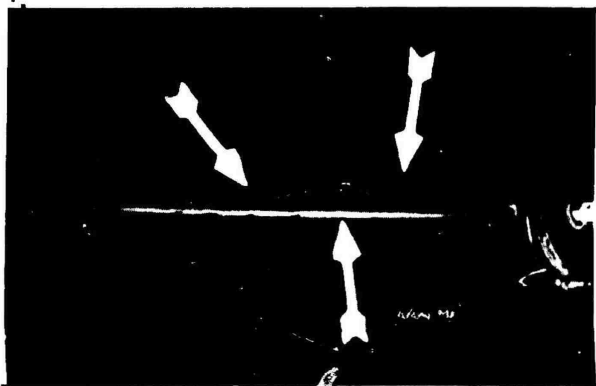

Figure 2.11-10: Buckled Vertical Panel of Right-Rear Wheel Well.

2.11.3.8 Group 16, Springs and Shock Absorbers. The newly designed rear-axle bump stops (lower durometer), installed during vehicle modification to reduce the harsh bump, split in the seam as shown in Figure 2.11-11 after 5569 test miles. A second set of bump stops were installed and had to be replaced after 2003 test miles as a result of deterioration as shown Figure 2.11-12.

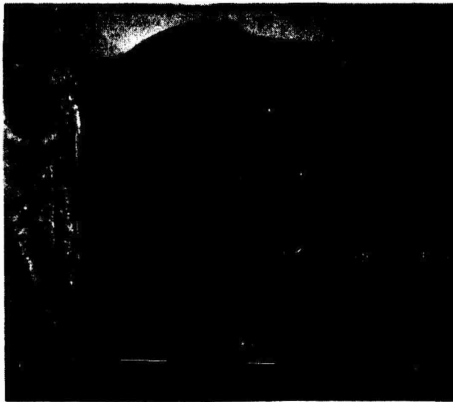

Figure 2.11-11: Split in Seam of Rear-Axle Bump Stop.



Figure 2.11-12: Deteriorated Rear-Axle Bump Stop.

SECTION 3. APPENDICES

APPENDIX I - EP SUMMARY SHEETS

EP SUMMARY SHEET
(TECP 700-700
Interim Pam. 60-20)

TYPES OF INCIDENTS

A - DEFICIENCY D - DESIGN

B - SHORTCOMING M - MANUFACTURING

C - SUGGESTED IMPROVEMENT 0 = Other

PROJECT:

USATECOM PROJECT NO:

SML GRP	VEH NO.	AFC NO.	TYPE	ITEM	PART NO.	PART MILEAGE	VEH ODOM	REMARKS				
									INCIDENT			
01		47	B/M	<u>Engine</u> Right engine-mounting bolt	96906-35298-88	9038	9111	Torque, 5 lb-ft. Tightened to 75 lb-ft.				
									8754320	11109	11199	Leaking at rear.
									9690-	12199	12289	Loose.
									35298-88	15064	15154	Contained seven cracks.
									8754540	20131	20221	Cracked in two places.
									8754623	20131	20221	Contained a crack.
									8754676			
02		54	0	<u>Clutch</u> Clutch pedal	Jnk	-	11199	Installed experimental pedal.				
									57	11444	11534	Seized.
									57-2	8687	20221	Rough and dry.
									86	20131	20221	Packing missing on one end and damaged on other end of shaft.
03		7	B/M	<u>Fuel System</u> Fuel-tank cap gasket	7375020	998	0171	Fuel leaked past gasket				
									63	14607	14697	Stretched and leaking.

EP SUMMARY SHEET
(TECP 700-700
Interim Pam. 60-20)

PROJECT: _____
USATECOM PROJECT NO: _____

TYPES OF INCIDENTS
A - DEFICIENCY D - DESIGN
B - SHORTCOMING M - MANUFACTURING
C - SUGGESTED IMPROVEMENT O - Other

EPL REP	VEH NO.	APC NO.	TYPE	INCIDENT			PART NO.	PART MILEAGE	VEH NO.	REMARKS
				ITEM						
04		28	B/M	<u>Exhaust System</u>		7331256	4542	4615	Hole worn in cross-over pipe due to rubbing front propeller shaft.	
		28-2	O	Exhaust pipe		7331256	6404	6477	Replaced cross-over pipe.	
		36	B/D	Exhaust-pipe clamp		Jnk	7995	8068	Rear clamp on tail pipe loosened.	
		36-2	B/D	Exhaust-pipe clamp		Jnk	20131	20221	Second from rear clamp broke.	
05				<u>Cooling System</u>						
		38	B/M	Upper radiator mount		8754191	8433	8506	Front stud pulled out of rubber body.	
		38-2 85	B/M A/M	Upper radiator mount Engine coolant fan		8754191 8342323	2676 20131	11199 20221	Front stud pulled out of rubber body. Cracked in two places.	

EP SUMMARY SHEET
(TECP 700-700
Interim Pam. 60-20)

TYPES OF INCIDENTS

- A - DEFICIENCY B - DESIGN
- B - SHORTCOMING M - MANUFACTURING
- C - SUGGESTED IMPROVEMENT O - Other

PROJECT: _____

USATECOM PROJECT NO: _____

SRL GRP	VEH FD.	AFC NO.	TYPE	ITEM	PART NO.	PART MILEAGE	VEH ODOM	REMARKS
06				<u>Electrical System</u>				
		5	B/M	Wiring harness	Jnk	677	750	Lower lead to horn loose.
		8	B/M	Alternator cooling fan	Jnk	1431	1504	Loose due to cap screw loosening in end of armature shaft.
		14	B/M	High-beam indicator lamp	454732	3239	3312	Burned out.
		20	B/M	Ignition system	NA	3239	3312	Timing shifted from 6° to 9° BTDC.
		26	B/M	Wiring harness	Jnk	4247	4320	Lead damage by edge of hood.
		32	O	Ignition-point set	7059538	6404	6477	Adjusted point gap from 0.012 inch to 0.020 inch.
		33	O	Spark plugs	83557724	6404	6477	Adjusted plug gaps from 0.037 inch to 0.030 inch.
		14-2	B/M	High-beam indicator lamp	454732	5669	8981	Burned out.
		43	B/M	Turn-signal lamp	Jnk	9038	9111	Left rear lamp burned out.
		32-2	B/M	Ignition-point set	7059538	9038	9128	Replaced.
		33-2	B/M	Spark plugs	83557724	9043	9133	Replaced.
		58	B/M	Turn-signal lamp	Jnk	12202	12292	Right front lamp burned out.
		33-3	B/M	Spark plugs	83557724	3433	12569	Breaking down, replaced.
		59	B/M	Oil-pressure sending unit	MS-24538-1	12530	12620	Replaced.
		60	B/O	Oil-pressure gage	MS-24541-1	12914	13004	Replaced.
		14-3	B/M	High-beam indicator lamp	454732	6807	15788	Burned out.
		32-3	B/M	Ignition-point set	7059538	9011	18139	Replaced.
		14-4	B/M	High-beam indicator	454732	4433	20221	Inoperative.

EP SUMMARY SHEET
(TECP 700-700
Interim Pam. 60-20)

PROJECT:

USATECON PROJECT NO:

TYPES OF INCIDENTS

- A - DEFICIENCY
- B - DESIGN
- C - MANUFACTURING
- D - SUSTAINING
- E - MANUFACTURING
- F - SUGGESTED IMPROVEMENT

SPL. GRP. NO.	VEH. NO.	INCIDENT			PART NO.	PART MILEAGE	VEH. ODOM.	REMARKS
		AVG. NO.	TYPE	ITEM				
07				<u>Transmission</u>				
	30	B/M		Transmission	4662	4735	Hot and seeping lubricant; tightened speedometer drive.	
	56	A/M		Cluster gear	11444	11534	2-1/2 teeth of 3rd gear failed.	
	65	B/D		Parking-brake drum-retaining screw	MS-35306-14513	14603	Loose; tightened to 65 lb-ft.	
	71	B/D		Transmission mounting bolts	MS-35306-17185	17275	Threads damaged due to being loose.	
	82	B/D		Shifter-shaft seal	7979499	20131	Seal was leaking. End play of rear output shaft was 0.113 inch.	
	08				<u>Transfer Assembly</u>			
		49	B/D		Rear output-flange lock nut	9038	9111	Torque, 50 lb-ft; tightened to 100 lb-ft.
61		B/M		Front output-shaft seal	7996802	13004	Leaking, replaced.	
75		B/D		Front and rear output-shaft seals	7996802	18139	Leaking, replaced.	
76		B/D		Front output flange	8359974	18049	Worn excessively.	
09					<u>Propeller Shafts</u>			
	35	A/D		Rear propeller shaft	7288	7361	Shaft was bent approximately 1/2 inch at the center.	
	77	A/D		Front propeller shaft	18049	18139	Rear U-joint cross was brinnelled.	
	35-2	A/D		Rear propeller shaft	11093	20221	Front U-joint cross was brinnelled.	
	77-2	A/D		Front propeller shaft	20131	20221	Deformed.	

EP SUMMARY SHEET
(TECP 700-700
Interim Pam. 60-20)

TITLE OF INCIDENT

A - DEFICIENCY B - DESIGN

C - SUCCESSFUL IMPROVEMENT O - Other

PROJECT:

USATECOM PROJECT NO:

EOL CRP	VER NO.	APC NO.	TYPE	INCIDENT			PART NO.	PART RELEASE	VER ORDN	REMARKS	
				ITEM	ITEM	ITEM					
12		10	A/D	<u>Brakes</u>			7025867	1711	1784	Inadequate gasket surface between plate and axle tube. Cleaned and adjusted.	
		23	0	Service brakes			NA	4027	4100	Adjusted.	
		23-2	0	Service brakes			NA	6404	6477	Adjusted.	
		10-2	B/D	Rear-wheel backing plates			7025867	6404	6477	Backing-plate gaskets deteriorated.	
		34	0	Parking brake			Unk	6404	6477	Adjusted.	
		34-2	0	Parking brake			Unk	9043	9133	Adjusted.	
		55	0	Brake pedal			Unk	-	11199	Installed experimental pedal.	
		56	B/O	Service brakes			Unk	14564	14644	Replaced all brake shoes.	
		56-2	B/O	Service brakes			Unk	3247	17981	Replaced rear-wheel brake shoes.	
	13				<u>Wheels, hubs, Drum</u>						
		13	A/M	Inner tube			MS-35392-8	3005	3073	Slow leak; left front.	
		41	0	Tire, 7.00 x 16, lightweight			MS-35388-93	9036	9109	Rear tires replaced.	
		42	A/M	Tire, 7.00 x 16, lightweight			MS-35388-93	9038	9111	Left front tire cut in tread.	
		41-2	A/O	Left rear tier			MS-35388-93	1771	10897	Punctured by stone; replaced.	
		41-2	0	Left rear tire			MS-35388-93	8433	19430	Replaced due to break.	
		41-3	0	Tire, 7.00 x 16, lightweight			MS-35388-93	10432	19543	Replaced.	
		42-2	0	Tire, 7.00 x 16, lightweight			MS-35388-93	11183	20221	Front tire worn out.	

EP SUMMARY SHEET
(TECP 700-700
Interim Pam. 60-20)

PROJECT: _____

USATRCON PROJECT NO: _____

TYPES OF INCIDENTS

A - DEFICIENCY B - DESIGN

C - MAINTENANCE M - MANUFACTURING

D - MISUSE/STRESS DEPLOYMENT O - Other

SOL GRP	VEN NO.	A/C NO.	TYPE	INCIDENT			PART NO.	PART RELEASE	VEN NOON	REMARKS
				ITEM	ITEM	ITEM				
14				<u>Controls</u>						
	12		B/M	Choke-cable retaining clip		Unk	2433	2506	Missing.	
	84		B/O	Steering-column grommet		Unk	20131	20221	Cracked.	
				<u>Frame and Brackets</u>						
15				Longitudinal frame rails		NA	8761	8834	Deformed in areas of rear axle bump stops.	
	40		B/D	Longitudinal frame rails		NA	9038	9111	Deformation increased and test was suspended.	
	40-2		A/D	Longitudinal frame rails		Unk	3500	13628	Loose.	
				Pintle-mounting bolts						

EP SUMMARY SHEET
(TECP 700-700
Interim Pam. 30-20)

TYPES OF INCIDENTS

A - DEFICIENCY D - DESIGN

B - SHORTCOMING M - MANUFACTURING

C - SUGGESTED IMPROVEMENT

PROJECT:

USATECOM PROJECT NO:

SRL GRP	VEH NO.	ARC NO.	TYPE	INCIDENT			PART NO.	PART MILEAGE	VEH ODOH	REMARKS
				ITEM						
17		37	B/M	Hood and Fenders		96906-35335-18	8201	8274	Front screw broke.	
18		6	B/D	Body and Cab		Unk	677	750	Ineffective.	
		22	A/D	Floor-panel drains		Unk	3854	3927	Panel above muffler too hot.	
		39	B/M	Floor panel		Unk	8511	8584	Cracked and bolt pulled out.	
		67	B/M	Spare-tire mounting bracket		Unk	5554	14682	Sheared off.	
		67-2	B/M	Spare-tire mounting bolt		Unk	-	-	Lug nut could not be used since replacement bolt had standard threads.	
		70	B/D	Spare-tire mounting bolt		Unk	17185	17275	3-inch crack in body at rear of transmission tunnel cover.	
		81	B/D	Floor panel		Unk	20131	20221	Condition was unsatisfactory.	
				Body and frame						

EP SUMMARY SHEET
(TECP 700-700
Interim Pam. 60-20)

TYPES OF INCIDENTS

- A - DEFICIENCY D - DESIGN
- B - SHORTCOMING M - MANUFACTURING
- C - SUGGESTED IMPROVEMENT O - Other

PROJECT: _____

USATECOM PROJECT NO: _____

SRL GRP	VEH NO.	INCIDENT			PART NO.	PART MILEAGE	VEH DOOR	REMARKS
		ARC NO.	TYPE	ITEM				
22				<u>Miscellaneous Accessories</u>				
		11	B/M	Left door	8754975	2433	2506	Vertical zipper stuck open.
		24	O	Vacuum pump	-	4247	4320	Replaced with modified pump (XG-8392431).
		25	O	Vacuum pump to intake-manifold tube	8754551	4247	4320	Replaced with transparent tube.
		45	B/D	Rear-seat assembly	Unk	9038	9111	Legs cracked were they are welded to frame.
		46	B/D	Right rear tie-down shackle	XG-8392	9038	9111	Strikes rear end of spring.
		53	O	Vacuum pump	431	-	11199	Installed experimental pump.
		53-2	B/D	Vacuum pump	XG-8392 431	9022	20221	Oil was found on both sides of diaphragm.
			<u>Miscellaneous</u>					
		1	-	Receipt of vehicle	-	0	73	
		2	-	Start of test	-	0	73	
		3	-	Receipt of vehicle after modifi- cation	-	9038	9128	

APPENDIX II - PHOTOGRAPHS

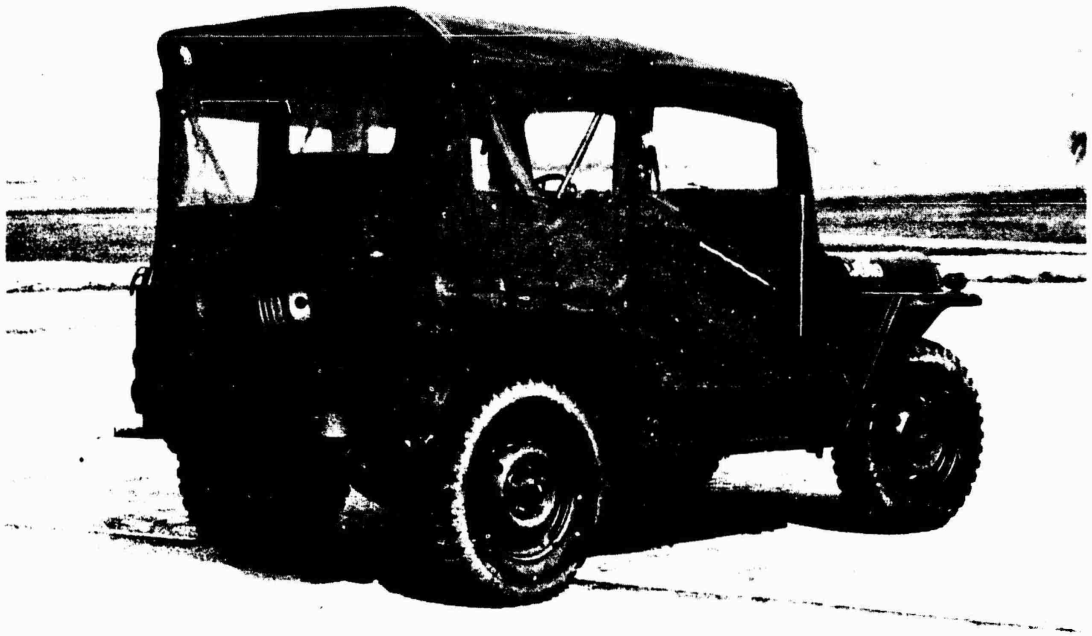

Figure II-1, 1928-66: Three-Quarter Right Rear View.



Figure II-2, 1926/66: TOP: Rear View. BOTTOM: Front View.

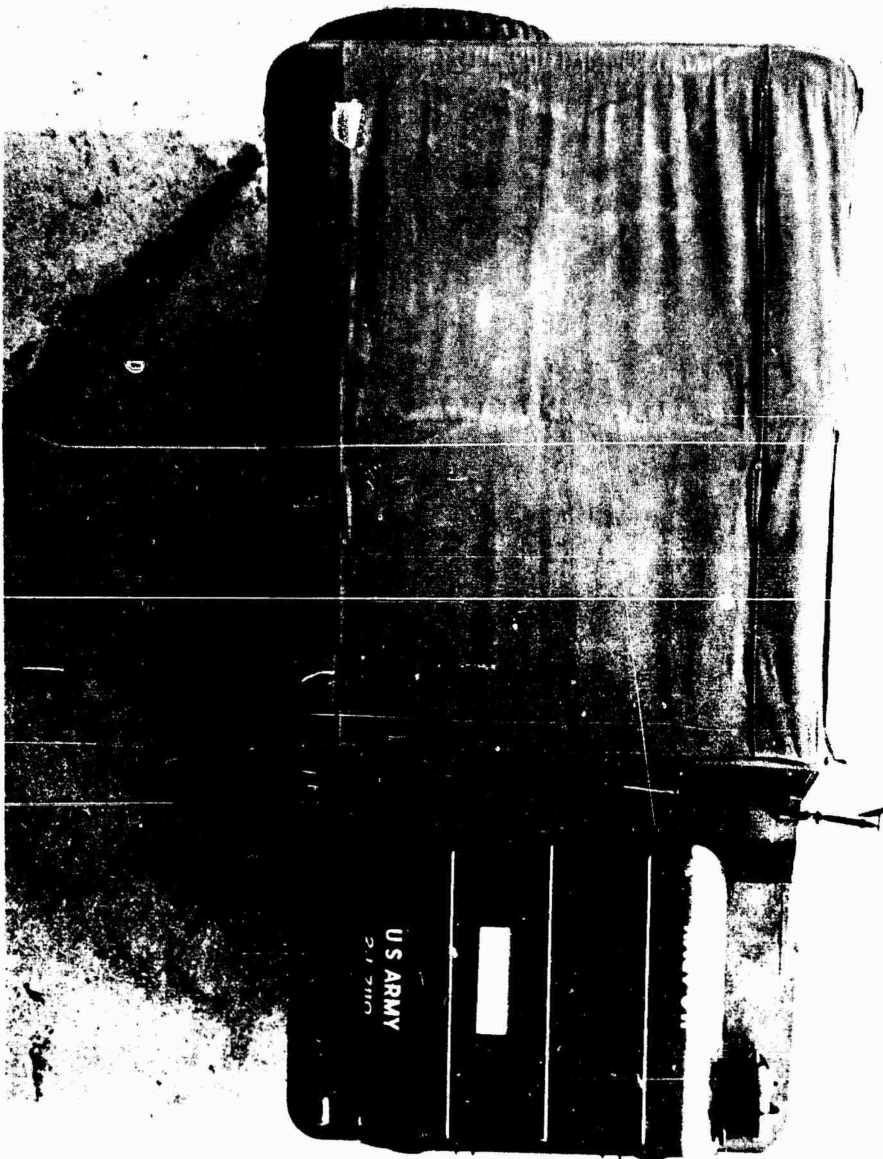

Figure II-3, 1925/66: Top View.

APPENDIX III - CORRESPONDENCE

PROCUREMENT/WORK DIRECTIVE (AMCR 11-13)				1. TRANSMITTAL CONTROL NUMBER K2-09-001	2. PAGE 1 OF 4 PAGES	3. PRIORITY 98
4. TO: USAF/TECOM Aberdeen Proving Ground ATTN: STEAP-DS-TU Aberdeen, Maryland				5. APPROVED BY: <i>[Signature]</i> DENNIS MEDREA, JR. Ch, Prog Mgt Br, GPV	6. BASIC FACT CODE: A31315632	7. DATE 6048
8. FROM: Project Manager, GPV ATTN: AMCPM-GP-MPM Warren, Michigan 48090				9. AUTHORIZED BY: <i>[Signature]</i> C. F. NOWOSIELSKI Ch, Prog Mgt Div, GPV	10. PROJECT NO./CATEGORY CODE: 11E3 001 1	
11. CMS TITLE/ITEM NOMENCLATURE: Truck, Utility, 1/2 Ton, 4x4, M151				12. CUSTOMER ORDER NUMBER: AL-G-13310-A1-30	13. FROM: 30-6-GP794-01-30-K2	
14. AMCHS CODE: 4510.04, 3101.1		15. ACCOUNTING CLASSIFICATION: 21X2030 664-3000 P4510 20-113			16. DATE DISP. CV-2-13353 6 048	
17. QUANTITY ON ORDER:		18. TARGET DATE FOR OBLIGATION:		19. LOCAL USE:		
20. QUANTITATIVE AND CHANGE DATA						
ELEMENT	U/M	QUANTITY	UNIT PRICE	TOTAL PRICE		
a. PRIOR						
b. TOLERANCE USED						
c. INCREASE		N/A				
d. DECREASE						
e. CURRENT		N/A				
f. TOLERANCE				NONE		
21. REPORT CODE: A			22. TYPE OF FINANCING: 6		Funds Certified	
23. DESCRIPTION OF WORK AUTHORIZED/SPECIAL INSTRUCTIONS/ENCLOSURES:						
<p>The purpose of this order is to provide Program and Funding Authority to conduct a Product Improvement Test on one (1) each Truck, Utility, 1/2 Ton, M151 (with solid axle rear suspension) in accordance with the following test program:</p> <p style="text-align: center;"><u>Test Program</u></p> <ol style="list-style-type: none"> 1. Testing shall be conducted as follows: <ol style="list-style-type: none"> a. OPM 60-25 - Vehicle Inspection. b. TECP 700-700 - (Interim Pamphlet 60-30) - Preliminary Operation c. OPM 60-80 - Gradeability and Side Slope Performance <p style="text-align: right;">(Continued on AMC Form 1006A) <i>LD</i></p>						
23-1 This is a <input checked="" type="checkbox"/> Project Order, Fixed Price; <input checked="" type="checkbox"/> Project Order, Cost Reimbursable; <input type="checkbox"/> Intra-Army Order for Reimbursable Work or Service.						
The work or services will be performed as ordered herein. Expiration date of this order: <u>31 December 1966</u>						
23-2 The above terms and conditions are satisfactory and are accepted.						
Typed Name & Title of Accepting Officer			Signature		Date	
24. PACKAGING, PACKING AND MARKING SHALL BE IN ACCORDANCE WITH: Funds cited are available						
25. DISTRIBUTION PATTERN:				BASIC FACT CODE:		STOCK NUMBER:
4. DEPT	DOC IDENT	SI FROM	U/I	QTY	CUST DOC NUMBER	SUPPL ADDRESS
UNIT PACK:			INTER PACK:		CONSIGNMENT:	
P & P LEVEL:			PACKING LEVEL:			
0	0	0	0	0	0	0
0	0	0	0	0	0	0

CONTINUATION OR SUPPORTING SHEET
(AMC REG)

PAGE	2	OF	4	PAGES
PRON	30-6-G	94	AMCMS CODE	
	01-30-K2		4510.04.3101.1	

- d. Weight Distribution
- e. TECP 700-700 (Interim Pamphlet 60-65) - Center of Gravity
- f. Execute a sufficient number of Panic Stops to determine braking stability
- g. TECP 700-700 - (Interim Pamphlet 60-50) - Standard Obstacles
Operate modified vehicle unloaded and with rated payload over standard obstacle courses appropriate for this class vehicle.
- h. Draw Bar Pull and Full Load Cooling
- i. The following test cycle should be repeated four times for a total of 20,000 miles:
 - (1) Paved Highway - 1,050
 - (2) Level Cross-Country - 1,900
 - (3) Hill Cross-Country - 1,900
 - (4) Belgium Block - 150

2. Reporting on tests shall be as follows:

- a. Problems or difficulties will be reported as they occur by telephone and teletype to AMCPM-GP-TLV (ATTN: Mr. M. E. Burcz and/or Mr. E. E. Woessner, Ext 648/492).
- b. Interim reports will be periodically forwarded to the Project Manager on the progress of the testing.
- c. A formal report will be prepared within thirty (30) days after completion of the test.
- d. Distribution list for final report is as follows:

Commanding General
US Army Test and Evaluation Command
Aberdeen Proving Ground, Maryland 21005
ATTN: AMSTE-BE - 1 copy
AMSTE-TA - 1 copy

CONTINUATION OR REPORTING SHEET (AMC REG 11-2)	PAGE	3	OF	4	PAGES
	PRON	30-6-AP794 01-30-K2	AMCMS CODE	4510.04.3101.1	

Project Manager's Office,
General Purpose Vehicles
Michigan Army Missile Plant
Warren, Michigan 48090
ATTN: AMCPM-GP-TLV - 10 copies

Commanding General
US Army Tank-Automotive Center
Warren, Michigan 48090
ATTN: SMOTA-RTT - 20 copies

Commanding Officer
Yuma Proving Ground
Yuma, Arizona 85364 - 1 copy

Commanding Officer
Jefferson Proving Ground
Madison, Indiana 47251 - 1 copy

Commanding Officer
Erie Proving Ground
Port Clinton, Ohio 43452 - 1 copy

Commanding Officer
US Army Arctic Test Center
APO Seattle, Washington 98733 - 1 copy

Commanding Officer
Aberdeen Proving Ground
Aberdeen Proving Ground, Maryland 21005
ATTN: STEAP-TL - 2 copies

Commander
HQ, Defense Documentation Center for Scientific
and Technical Information
Cameron Station
Alexandria, Virginia 22314
ATTN: Document Service Center - 20 copies

Ford Motor Company
Special Military Vehicles Operations
P.O. Box 2053
Dearborn, Michigan
ATTN: Mr. C. Mauch - 10 copies

CONTINUATION OR SUPPLEMENTARY SHEET (AMC REG 1.21)	PAGE 4	OF 4	PAGES
	PRON 30-6-794- 01-30-K2	AMCHS CODE 4510.04.3101.1	

3. Replacement parts for the test vehicles will be obtained through normal supply lines by the testing agencies, with the exceptions of those special test parts which are not in the supply system plus any standard component that cannot be obtained from supply.

4. Testing should be conducted on a 24-hour basis, 7 days a week.

5. It is requested that failed vehicle components be sent to the Ford Motor Company, Special Military Vehicles Operations, ATTN: Mr. H. J. Zaidel, 2001 Beech Daly Road, Dearborn Heights, Michigan, for evaluation and consideration of possible engineering changes. Disposition instructions for the test vehicles will be furnished during or after completion of tests.

PROCUREMENT/WORK DIRECTIVE (AMCR 11-15)		1. TRANSMITTAL CONTROL NUMBER K2-03-0004	2. PAGE 1 OF 1 PAGES	3. PAGES 98
4. TO:	CG, USATECOM Aberdeen Proving Ground ATTN: STEAP-D5-TU Aberdeen, Maryland	5. APPROVED BY <i>[Signature]</i> DENNIS MEDREN, Jr. Ch. ProgMgt Br. GPV	6. BASIC FACT CODE: A31315633	7. DATE 6078
8. FROM:	Project Manager ATTN: AMCPM-GP-MPM Warren, Michigan 48090	9. AUTHORIZED BY <i>[Signature]</i> MOWOSTELSKI Ch. ProgMgt Div, GPV	10. PROJECT NO./CATEGORY CODE: 11E3 001 1	
11. CMS TITLE/ITEM NOMENCLATURE: Truck, Utility, 1/4 T, 4x4, M151	12. CUSTOMER ORDER NUMBER: A1-6-13310-A1-30	13. PRON: 30-6-GP794-02-30-K2		
14. AMCRS CODE: 4510.04.3101.1	15. ACCOUNTING CLASSIFICATION: 21X2030 664-3000 P4510 20-113	16. DATE DISP: 6078		
17. QUANTITY ON ORDER:	18. TARGET DATE FOR OBLIGATION:	19. LOCAL USE:		
20. QUANTITATIVE AND CHANGE DATA				
ELEMENT	U/M	QUANTITY	UNIT PRICE	TOTAL PRICE
a. PRIOR		N/A		
A. TOLERANCE USED				
c. INCREASE		N/C		N/C
d. DECREASE				
e. CURRENT		N/A		
f. TOLERANCE				NONE
21. REPORT CODE: A	22. TYPE OF FINANCING: 6	Funds Certified		
23. DESCRIPTION OF WORK AUTHORIZED/SPECIAL INSTRUCTIONS/INCLOSURES: The purpose of this amendment is to provide the following list of major components applicable to the Product Improvement Test of one (1) each Truck, Utility, 1/4 Ton, M151 (with solid axle rear suspension): <u>List of New Major Components</u> <ul style="list-style-type: none"> (1) Solid Rear Axle Assembly (2) Front Differential Assembly (3) Front Propeller Shaft Assembly (4) Rear Propeller Shaft Assembly (5) Transfer Gear Case Assembly (6) Rear Leaf Springs (7) Muffler Tailpipe (8) Front and Rear Shock Absorbers (9) Front Coil Springs (10) Body Assembly (11) Rear Brake Line 				
23-1 This is a <input checked="" type="checkbox"/> Project Order, Fixed Price; <input checked="" type="checkbox"/> Project Order; Cost Reimbursable; <input checked="" type="checkbox"/> Intra-Army Order for Reimbursable Work or Service. The work or services will be performed as ordered herein. Expiration date of this order: <u>31 DEC 1966</u>				
23-2 The above terms and conditions are satisfactory and are accepted.				
Typed Name & Title of Accepting Officer		Signature		Date
ADDRESS		ADDRESS		DATA
UNIT PAGE	UNIT PAGE	COMMENTS		
UNIT PAGE	UNIT PAGE	PACKING LEVEL		



OFFICE OF THE PROJECT MANAGER
GENERAL PURPOSE VEHICLES
UNITED STATES ARMY MOBILITY COMMAND
WARREN MICHIGAN 48090

AMCPM-GP-TLV

5 April 1966

SUBJECT: Product Improvement Test of Truck,
Utility, 1/4 Ton, 4x4, M151 (Solid
Axle Rear Suspension)

TO: Commanding Officer
Aberdeen Proving Ground
ATTN: STEAP-DS-TU, Mr. D. Liechty
Aberdeen, Maryland

Delete the distribution list for reporting
test results in Work Directive PRON 30-6-GP794-
01-30-K2, and replace it with the following
distribution:

a. Distribution list for formal report:

Project Manager's Office,
General Purpose Vehicles
Michigan Army Missile Plant
Warren, Michigan 48090
ATTN: AMCPM-GP-TLV - 20 copies

Commanding General
U. S. Army Tank-Automotive Center
Warren, Michigan 48090
ATTN: SMOTA-RTT - 2 copies

Commanding Officer
Yuma Proving Ground
Yuma, Arizona 85364 - 1 copy

AMCPM-GP-TLV

5 April 1966

SUBJECT: Product Improvement Test of Truck,
Utility, 1/4 Ton, 4x4, M151 (Solid
Axle Rear Suspension)

Commanding Officer
Aberdeen Proving Ground
Aberdeen Proving Ground, Maryland 21005
ATTN: STEAP-TL - 2 copies

Commander
HQ, Defense Documentation Center for Scientific
and Technical Information
Cameron Station
Alexandria, Virginia 22314
ATTN: Document Service Center - 20 copies

Commanding General
U. S. Army Test & Evaluation Command
Aberdeen, Maryland 21005
ATTN: AMSTE-BB - 1 copy and
ATTN: AMSTE-TA - 1 copy

Commanding Officer
U. S. Army Armor Board
Fort Knox, Kentucky
ATTN: STEBB-GT, Maj. Sterling - 1 copy
Lt. Cole - 1 copy

b. Distribution list for interim and equipment
failure reports:

Project Manager's Office,
General Purpose Vehicles
Michigan Army Missile Plant
Warren, Michigan 48090
ATTN: AMCPM-GP-TLV - 10 copies

AMCPM-GP-TLV

5 April 1966

SUBJECT: Product Improvement Test of Truck,
Utility, 1/4 Ton, 4x4, M151 (Solid
Axle Rear Suspension)

Commanding General
U. S. Army Test & Evaluation Command
Aberdeen, Maryland 21005
ATTN: AMSTE-BB - 1 copy

Commanding Officer
U. S. Army Armor Board
Fort Knox, Kentucky
ATTN: STEBB-GT, Maj. Sterling - 1 copy
Lt. Cole - 1 copy

FOR THE PROJECT MANAGER:

Robert A. Hayden
for LOUIS MORTENSON *mjg/6-5*
Chief, Technical Management Division

Copies furnished:
AMSTE-BB

COPY/es

NNNNZCZCARK784EUA432YEA777

DATE: 10 JUN 66

RR RUEPARA

ACTION: D&PS

DE RUCDGBB 36M 1601916

ZNR UUUUU

R 191900Z

FM PROJ MGR GPV MICH ARMY MISSILE PLANT WARREN MICH

TO RUEPARA/CO ABERDEEN PROVING GROUND MD

INFO RUEPARA/CG US ARMY TEST & EVALUATION COMMAND ATTN AMSTE-NB

COL SNEIDER APC MD

BT

UNCLAS TT6-4887 FOR STEAP-DS-TU, MR. LIECHTY FROM AMCPM-GP-T

SUBJ: PRODUCT IMPROVEMENT TEST OF M151A1 TRUCK MODIFIED WITH
SOLID REAR AXLE

1. IT IS REQUESTED THAT VEHICLE 2J7110 (M151A1) BE SHIPPED TO
FORD MOTOR CO., SPECIAL MILITARY VEHICLES OPERATIONS, 2001 BEECH
DALY RD, DEARBORN HEIGHTS, MICH, ATTN: MR. F. AVEY, AS SOON AS
POSSIBLE. SHIP THE VEHICLE BY COMMERCIAL TRUCK CARRIER COD,
FORD MOTOR CO.

2. THE PURPOSE OF THIS ACTION IS TO PERFORM THE NECESSARY REPAIRS
TO ALLOW CONTINUATION OF DURABILITY TESTING OF THE VEHICLE

BT

NNNNZCZCARK

COPY/es

NNNZCZCARK 377EUA823YEC308

RR RUEPARA

DATE: 9 AUG 66

ACTION: D&PS

DE RUGDGBB 18M 2201816

ZNR UUUUU

R 081735Z AUG 66

FM PROJ MGR GPV MICH ARMY MISSILE PLANT WARREN MICH

TO CO ABERDEEN PROVING GROUND MARYLAND

BT

UNCLAS S-4566 FOR STEAP-DS-TU, D. LIECHTY FROM AMCPM-GP-T

SUBJECT: SOLID AXLE TEST PROGRAM

IT IS REQUESTED THAT NO LUBRICATION OF THE SOLID AXLE WHEEL BEARING BE ACCOMPLISHED FOR THE DURATION OF THE TEST. THIS REQUEST DOES NOT NEGATE REPLACEMENT OF THE WHEEL BEARINGS OR ON THE TEST VEHICLE WHEN NECESSARY.

BT

COPY/es

NNNN0ZCAFA933

RTTU JAW RUCIFDA5224 3361424-UUUU--RUEOFAA.

ZNR UUUUU

DATE: 2 DEC 66

ACTION: D&PS

R 021420Z DEC

INFO: INSTAL SUP
TRANSP

FM PROJ MGR GPV MAMP WARREN MICH

TO RUEOFAA/CO DEVELOPMENT & PROOF SERVICES APG MD

INFO RUEOFFA/CG USATECOM APG MD

BT

UNCLAS TT12-4855 FOR D&PS, STEAP-DS-TU, MR. D. LIECHTY;

USATECOM, AMSTE-BB, MR. C. WATERS

SUBJECT CLN PRODUCT IMPROVEMENT TEST OF TRUCK, UTILITY

1/4 TON, 4X4, M151A1 (MODIFIED WITH SOLID REAR AXLE), VEHICLE NO. 2J7110

1. THIS OFFICE AUTHORIZES DELETION OF THE FULL LOAD COOLING AND THE DRAW BAR PULL TESTS FROM THE TEST DIERCTIVE.

2. AT COMPLETION OF THE TEST, IT IS REQUESTED THAT THE TEST VEHICLE BE SHIPPED TO FORD MOTOR CO., SPECIAL MILITARY VEHICLES OPERATIONS, 2001 BEECH DALY RD, DEARBORN HEIGHTS, MICH., ATTN CLN MR. F. AVEY. ALSO, IT IS REQUESTED THAT THE VEHICLE BE RETURNED IN AN AS IS CONDITION AND NO REPAIRS BE MADE.

3. IN ADDITION, ALL SPARE PARTS PECULIAR TO THE TEST VEHICLE ARE TO BE SHIPPED TO THE ABOVE ADDRESS

BT

AD

Accession No.

Development and Proof Service, Aberdeen Proving Ground, Md. 21005
Final Report of USATECOM Project No. 1-6-4030-12, Product Improvement Test of Truck,
Utility, 1/4-Ton, 4x4, M151, Modified with Solid Rear Axle, March 1967
RDT&E Project No. Not Available, Report No. DPS-2309
Author C. M. Bryzek, Jr.
Secondary distribution controlled by the Project Manager
54 pages, 18 illustrations

Unclassified Report

A product improvement test was conducted on a truck, utility, 1/4-ton, 4x4, M151, modified with solid rear axle, at Aberdeen Proving Ground (APG) from 12 April to 30 December 1966. The purpose of this test was to determine the engineering performance and durability characteristics of the vehicle. The vehicle was subjected to limited engineering performance tests and 20,000-mile durability test. It was concluded that the M151 modified with solid rear axle was unsatisfactory due to lack of durability of a majority of the modified components.

AD

Accession No.

Development and Proof Service, Aberdeen Proving Ground, Md. 21005
Final Report of USATECOM Project No. 1-6-4030-12, Product Improvement Test of Truck,
Utility, 1/4-Ton, 4x4, M151, Modified with Solid Rear Axle, March 1967
RDT&E Project No. Not Available, Report No. DPS-2309
Author C. M. Bryzek, Jr.
Secondary distribution controlled by the Project Manager
54 pages, 18 illustrations

Unclassified Report

A product improvement test was conducted on a truck, utility, 1/4-ton, 4x4, M151, modified with solid rear axle, at Aberdeen Proving Ground (APG) from 12 April to 30 December 1966. The purpose of this test was to determine the engineering performance and durability characteristics of the vehicle. The vehicle was subjected to limited engineering performance tests and 20,000-mile durability test. It was concluded that the M151 modified with solid rear axle was unsatisfactory due to lack of durability of a majority of the modified components.

AD _____ Accession No. _____
Development and Proof Service, Aberdeen Proving Ground, Md. 21005
Final Report of USATECOM Project No. 1-6-4030-12, Product Improvement Test of Truck,
Utility, 1/4-Ton, 4x4, M151, Modified with Solid Rear Axle, March 1967
RDT&E Project No. Not Available, Report No. DPS-2309
Author C. M. Bryzek, Jr.
Secondary distribution controlled by the Project Manager
54 pages, 18 illustrations

Unclassified Report

A product improvement test was conducted on a truck, utility, 1/4-ton, 4x4, M151, modified with solid rear axle, at Aberdeen Proving Ground (APG) from 12 April to 30 December 1966. The purpose of this test was to determine the engineering performance and durability characteristics of the vehicle. The vehicle was subjected to limited engineering performance tests and 20,000-mile durability test. It was concluded that the M151 modified with solid rear axle was unsatisfactory due to lack of durability of a majority of the modified components.

AD _____ Accession No. _____
Development and Proof Service, Aberdeen Proving Ground, Md. 21005
Final Report of USATECOM Project No. 1-6-4030-12, Product Improvement Test of Truck,
Utility, 1/4-Ton, 4x4, M151, Modified with Solid Rear Axle, March 1967
RDT&E Project No. Not Available, Report No. DPS-2309
Author C. M. Bryzek, Jr.
Secondary distribution controlled by the Project Manager
54 pages, 18 illustrations

Unclassified Report

A product improvement test was conducted on a truck, utility, 1/4-ton, 4x4, M151, modified with solid rear axle, at Aberdeen Proving Ground (APG) from 12 April to 30 December 1966. The purpose of this test was to determine the engineering performance and durability characteristics of the vehicle. The vehicle was subjected to limited engineering performance tests and 20,000-mile durability test. It was concluded that the M151 modified with solid rear axle was unsatisfactory due to lack of durability of a majority of the modified components.

Unclassified
Security Classification

DOCUMENT CONTROL DATA - R&D		
<i>(Security classification of title, body of abstract and indexing annotation must be entered when the overall report is classified)</i>		
1. ORIGINATING ACTIVITY (Corporate author)		2a. REPORT SECURITY CLASSIFICATION
Development and Proof Services Aberdeen Proving Ground, Maryland 21005		Unclassified
		2b. GROUP
3. REPORT TITLE		
PRODUCT IMPROVEMENT TEST OF TRUCK, UTILITY, 1/4-TON, 4X4, M151, MODIFIED WITH SOLID REAR AXLE		
4. DESCRIPTIVE NOTES (Type of report and inclusive dates)		
Final Report 12 April through 30 December 1966		
5. AUTHOR(S) (Last name, first name, initial)		
Bryzek, C. M., Jr.		
6. REPORT DATE	7a. TOTAL NO. OF PAGES	7b. NO. OF REFS
MARCH 1967	54	0
8a. CONTRACT OR GRANT NO.	9a. ORIGINATOR'S REPORT NUMBER(S)	
Not applicable	DPS-2309	
b. PROJECT NO.	9b. OTHER REPORT NO(S) (Any other numbers that may be assigned this report)	
USATECOM Project No. 1-6-4030-12		
c.		
d.		
10. AVAILABILITY/LIMITATION NOTICES		
This document may be further distributed by any holder only with specific prior approval of the Project Manager, ATTN: AMCPM-GP-TLV.		
11. SUPPLEMENTARY NOTES	12. SPONSORING MILITARY ACTIVITY	
None	USATACOM	
13. ABSTRACT		
A product improvement test was conducted on a truck, utility, 1/4-ton, 4x4, M151, modified with solid rear axle, at Aberdeen Proving Ground (APG) from 12 April to 30 December 1966. The purpose of this test was to determine the engineering performance and durability characteristics of the vehicle. The vehicle was subjected to limited engineering performance tests and a 20,000-mile durability test. It was concluded that the M151 modified with solid rear axle was unsatisfactory due to lack of durability of a majority of the modified components.		

DD FORM 1473
1 JAN 64

Unclassified
Security Classification

Security Classification

14. KEY WORDS	LINK A		LINK B		LINK C	
	ROLE	WT	ROLE	WT	ROLE	WT

INSTRUCTIONS

1. **ORIGINATING ACTIVITY:** Enter the name and address of the contractor, subcontractor, grantee, Department of Defense activity or other organization (*corporate author*) issuing the report.
- 2a. **REPORT SECURITY CLASSIFICATION:** Enter the overall security classification of the report. Indicate whether "Restricted Data" is included. Marking is to be in accordance with appropriate security regulations.
- 2b. **GROUP:** Automatic downgrading is specified in DoD Directive 5200.10 and Armed Forces Industrial Manual. Enter the group number. Also, when applicable, show that optional markings have been used for Group 3 and Group 4 as authorized.
3. **REPORT TITLE:** Enter the complete report title in all capital letters. Titles in all cases should be unclassified. If a meaningful title cannot be selected without classification, show title classification in all capitals in parenthesis immediately following the title.
4. **DESCRIPTIVE NOTES:** If appropriate, enter the type of report, e.g., interim, progress, summary, annual, or final. Give the inclusive dates when a specific reporting period is covered.
5. **AUTHOR(S):** Enter the name(s) of author(s) as shown on or in the report. Enter last name, first name, middle initial. If military, show rank and branch of service. The name of the principal author is an absolute minimum requirement.
6. **REPORT DATE:** Enter the date of the report as day, month, year; or month, year. If more than one date appears on the report, use date of publication.
- 7a. **TOTAL NUMBER OF PAGES:** The total page count should follow normal pagination procedures, i.e., enter the number of pages containing information.
- 7b. **NUMBER OF REFERENCES:** Enter the total number of references cited in the report.
- 8a. **CONTRACT OR GRANT NUMBER:** If appropriate, enter the applicable number of the contract or grant under which the report was written.
- 8b, 8c, & 8d. **PROJECT NUMBER:** Enter the appropriate military department identification, such as project number, subproject number, system numbers, task number, etc.
- 9a. **ORIGINATOR'S REPORT NUMBER(S):** Enter the official report number by which the document will be identified and controlled by the originating activity. This number must be unique to this report.
- 9b. **OTHER REPORT NUMBER(S):** If the report has been assigned any other report numbers (*either by the originator or by the sponsor*), also enter this number(s).

10. **AVAILABILITY/LIMITATION NOTICES:** Enter any limitations on further dissemination of the report, other than those imposed by security classification, using standard statements such as:
 - (1) "Qualified requesters may obtain copies of this report from DDC."
 - (2) "Foreign announcement and dissemination of this report by DDC is not authorized."
 - (3) "U. S. Government agencies may obtain copies of this report directly from DDC. Other qualified DDC users shall request through _____."
 - (4) "U. S. military agencies may obtain copies of this report directly from DDC. Other qualified users shall request through _____."
 - (5) "All distribution of this report is controlled. Qualified DDC users shall request through _____."

If the report has been furnished to the Office of Technical Services, Department of Commerce, for sale to the public, indicate this fact and enter the price, if known.

11. **SUPPLEMENTARY NOTES:** Use for additional explanatory notes.
12. **SPONSORING MILITARY ACTIVITY:** Enter the name of the departmental project office or laboratory sponsoring (*paying for*) the research and development. Include address.
13. **ABSTRACT:** Enter an abstract giving a brief and factual summary of the document indicative of the report, even though it may also appear elsewhere in the body of the technical report. If additional space is required, a continuation sheet shall be attached.

It is highly desirable that the abstract of classified reports be unclassified. Each paragraph of the abstract shall end with an indication of the military security classification of the information in the paragraph, represented as (TS), (S), (C), or (U).

There is no limitation on the length of the abstract. However, the suggested length is from 150 to 225 words.

14. **KEY WORDS:** Key words are technically meaningful terms or short phrases that characterize a report and may be used as index entries for cataloging the report. Key words must be selected so that no security classification is required. Identifiers, such as equipment model designation, trade name, military project code name, geographic location, may be used as key words but will be followed by an indication of technical context. The assignment of links, rules, and weights is optional.



REPLY TO
ATTENTION OF

DEPARTMENT OF THE ARMY
PROGRAM EXECUTIVE OFFICE
COMBAT SUPPORT & COMBAT SERVICE SUPPORT
6501 EAST 11 MILE ROAD
WARREN, MICHIGAN 48397-5000

SFAE-CSS

22 MAR 2013

MEMORANDUM FOR Defense Technical Information Center (DTIC-OQ), 8725 John J. Kingman Road, Fort Belvoir, VA 22060-6218

SUBJECT: Change of Classification Level to 4M151 Truck Documents

1. Reference Defense Technical Information Center (DTIC) Infosec "RE: M151A2 Documents retrieval and review" direction email of 14 December 2012.
2. In accordance with the above reference, please change the classification and distribution level for the following documents:
 - a. Document.
 - (1) The DTIC AD#: ADB271644
 - (2) Title: M151 Transmission Clutch Hub Insert – P/N 7059129
 - (3) Date of Document: 29 February 1972
 - (4) New Distribution/Classification: Distribution A. Approved for public release; distribution is unlimited.
 - (5) Reason for Change: This document has been reviewed for Operations Security (OPSEC) and has been deemed to contain no OPSEC concerns. The documents are for the M151 Truck that has not been in the military inventory since the early 1980s; the vehicle and associated documents are obsolete.
 - (6) Date of Change: Immediately

b. Document 2.

- (1) The DTIC AD#: AD0474825
- (2) Title: ENGINEER DESIGN TEST OF TRUCK, UTILITY, 1/4-TON, 4X4, M151 (RIDE AND HANDLING CHARACTERISTICS)
- (3) Date of Document: 15 December 1965

SFAE-CSS

SUBJECT: Change of Classification Level to 4M151 Truck Documents

(4) New Distribution/Classification: Distribution A. Approved for public release; distribution is unlimited.

(5) Reason for Change: This document has been reviewed for OPSEC and has been deemed to contain no OPSEC concerns. The documents are for the M151 Truck that has not been in the military inventory since the early 1980s; the vehicle and associated documents are obsolete.

(6) Date of Change: Immediately

c. Document 3.

(1) The DTIC AD#: AD0857240

(2) Title: Product Improvement Test of Truck, Utility, 1/4-TON, 4X4, M151 Series with Modified Independent Rear Suspension System

(3) Date of Document: 27 June 1969

(4) New Distribution/Classification: Distribution A. Approved for public release; distribution is unlimited.

(5) Reason for Change: This document has been reviewed for OPSEC and has been deemed to contain no OPSEC concerns. The documents are for the M151 Truck that has not been in the military inventory since the early 1980s; the vehicle and associated documents are obsolete.

(6) Date of Change: Immediately

d. Document 4.

(1) The DTIC AD#: ADB273320

(2) Title: Bonded vs. Riveted Brake Lining Test

(3) Date of Document: 12 January 1977

(4) New Distribution/Classification: Distribution A. Approved for public release; distribution is unlimited.

SFAE-CSS

SUBJECT: Change of Classification Level to 4M151 Truck Documents

(5) Reason for Change: This document has been reviewed for OPSEC and has been deemed to contain no OPSEC concerns. The documents are for the M151 Truck that has not been in the military inventory since the early 1980s; the vehicle and associated documents are obsolete.

(6) Date of Change: Immediately

e. Document 5.

(1) The DTIC AD#: AD0810372

(2) Title: Product Improvement Test of Truck, Utility, 1/4-TON, 4X4, M151 Modified with Solid Rear Axle

(3) Date of Document: March 1967

(4) New Distribution/Classification: Distribution A. Approved for public release; distribution is unlimited.

(5) Reason for Change: This document has been reviewed for OPSEC and has been deemed to contain no OPSEC concerns. The documents are for the M151 Truck that has not been in the military inventory since the early 1980s; the vehicle and associated documents are obsolete.

(6) Date of Change: Immediately

f. Document 6.

(1) The DTIC AD#: ADB271624

(2) Title: Transmission Cluster Gear (M151 Vehicle)

(3) Date of Document: 06 March 1972

(4) New Distribution/Classification: Distribution A. Approved for public release; distribution is unlimited.

(5) Reason for Change: This document has been reviewed for OPSEC and has been deemed to contain no OPSEC concerns. The documents are for the M151 Truck that has not been in the military inventory since the early 1980s; the vehicle and associated documents are obsolete.

SFAE-CSS

SUBJECT: Change of Classification Level to 4M151 Truck Documents

(6) Date of Change: Immediately

3. The Point of Contact for this action is Robert Anick, Sr, email:
robert.d.anick.civ@mail.mil or COM (586) 282-8448.

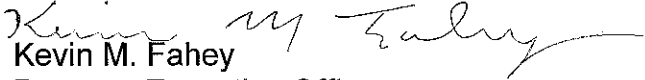
Kevin M. Fahey
Program Executive Officer,
Combat Support & Combat Service Support