

UNCLASSIFIED

AD NUMBER

AD814948

LIMITATION CHANGES

TO:

Approved for public release; distribution is unlimited.

FROM:

Distribution authorized to DoD only; Administrative/Operational Use; MAY 1967. Other requests shall be referred to R & E Division, Rock Island Arsenal, IL.

AUTHORITY

USAWC ltr 26 Jun 1974

THIS PAGE IS UNCLASSIFIED

AD

67-1197

ALTERNATE ARMAMENT COMBINATIONS
FOR THE M551 VEHICLE

FINAL REPORT



TECHNICAL REPORT

By

Robert Rossmiller

May 1967

U. S. ARMY WEAPONS COMMAND
ROCK ISLAND ARSENAL
RESEARCH & ENGINEERING DIVISION

AD814948

DISTRIBUTION

Each transmittal of this document outside the Department of Defense must have prior approval of the R&E Division, Rock Island Arsenal.

The findings in this report are not to be construed as an official Department of the Army position, unless so designated by other authorized documents.

DISPOSITION

Destroy this report when it is no longer needed. Do not return it to the originator.

RESEARCH & ENGINEERING DIVISION

U.S. ARMY WEAPONS COMMAND
ROCK ISLAND ARSENAL
RESEARCH & ENGINEERING DIVISION

TECHNICAL REPORT

67-1197

ALTERNATE ARMAMENT COMBINATIONS
FOR THE M551 VEHICLE

FINAL REPORT

BY

Robert Rosmiller
Development Engineering Branch

May 1967

DISTRIBUTION:

Each transmittal of this document outside the
Department of Defense must have prior approval
of the R&E Division, Rock Island Arsenal.

ABSTRACT

This is a final report of the analysis, design, manufacture, and test of alternate armament fired from the M551 Vehicle. Problem areas are discussed and solutions noted. Four systems were fired. One each of 76mm and 105mm with a hand operated breech, and one each of 76mm and 105mm with a semi-automatic breech. The recoil mechanisms used were the M76 and the one used with the M81E12 Cannon in the M551 Vehicle. All firings were instrumented and a summation of test results are tabulated. Any one of these systems could be optimized to be used in the M551 Vehicle.

FOREWORD

This work was conducted in support of the Army Weapons Command and the Sheridan Shillelagh Project Manager.

Support from outside agencies was vital and promptly executed. The many departments of AWC were especially helpful in furnishing information, drawings, hardware, and other technical data not available at RIA. Watervliet Arsenal furnished information and the XM180 Gun. Picatinny Arsenal manufactured inert warhead 76mm M352A1 rounds on short notice so that test firings could stay on schedule. The author also wishes to acknowledge Jerry Frantz of the Research & Analysis Section for the computer programs and Dick Holzworth of Combat Vehicle Section for the calculations found in the appendix. The work accomplished by Rock Island Arsenal, in the short time required, could not have been completed without the support of the team effort stated above.

TABLE OF CONTENTS

	<u>Page</u>
ABSTRACT	ii
FOREWORD	iii
OBJECT	1
INTRODUCTION	1
PROCEDURE	10
SUPPORTING WORK	16
PROBLEM AREAS & SOLUTIONS	17
HARDWARE	21
RESULTS	23
CONCLUSIONS & RECOMMENDATIONS	23
APPENDICES	
A. COMPUTER RESULTS	24
B. SUMMARY OF CALCULATIONS	31
C. TEST PROGRAM REQUEST & TEST & EVALUATION RANGE REPORT	46
D. TEST DATA	70
E. DRAWINGS	80
DISTRIBUTION	93

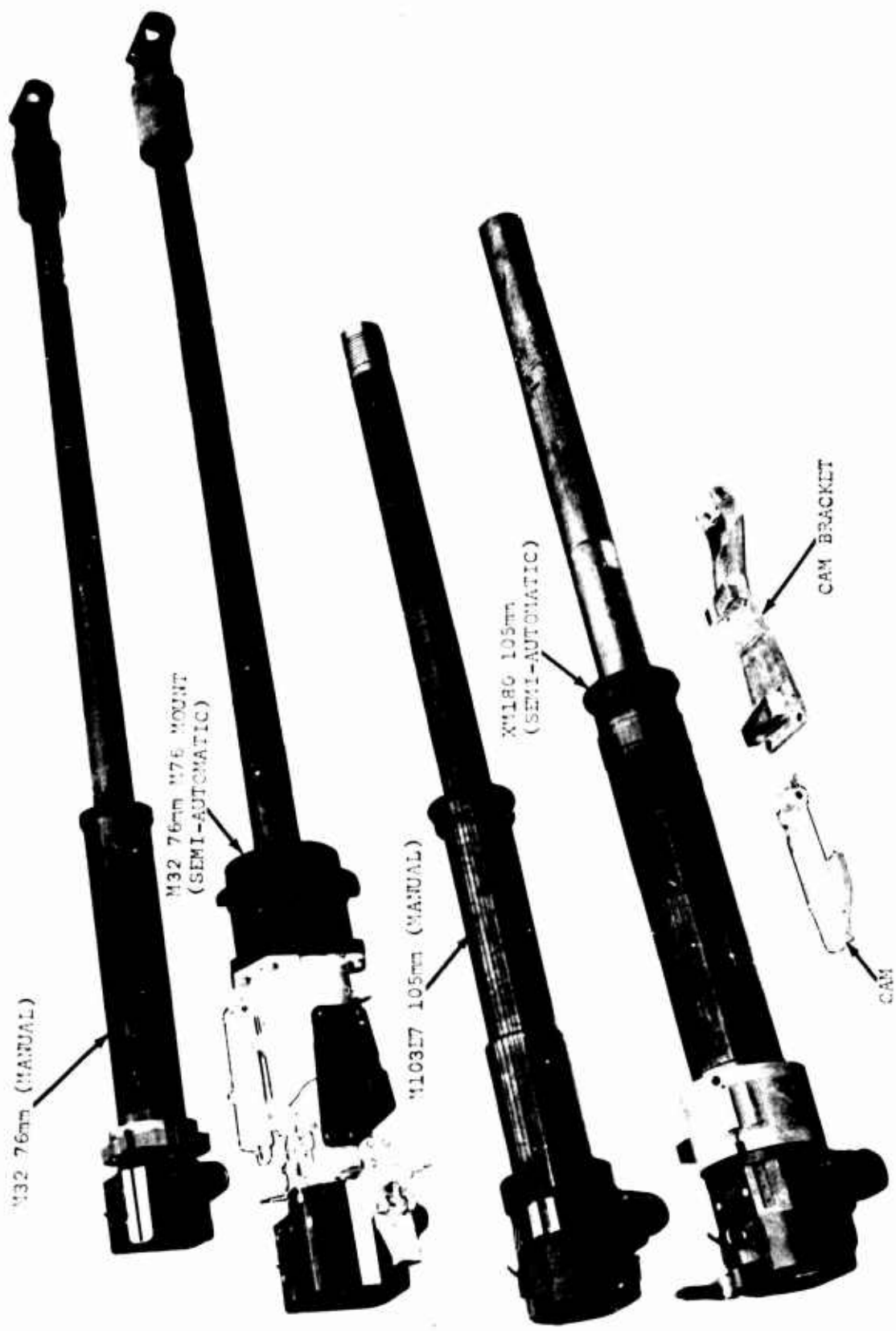

Figure 1

Alternate Hardware Fired From M551 Vehicle

OBJECT

To report on the work completed by Rock Island Arsenal from 24 February 1967 to 3 April 1967 relative to adapting various primary armament systems to the M551 Vehicle.

INTRODUCTION

On 24 February 1967 Rock Island Arsenal was informed of an urgent requirement to develop a back-up primary armament for the M551 Vehicle. This was in support of AWC and the Sheridan Shillelagh project manager. The design and manufacture of the test hardware was accelerated. Material used in the sleeve was made from scrapped 155mm gun tubes. An all-out effort was made to get the first four priority systems manufactured and test fired as soon as possible (See Figure 1). The first configuration was fired 11 March 1967. It consisted of an XM103E7 105mm Cannon with an adapter sleeve and collar made to fit the recoil mechanism for the M81E12 Cannon in the M551 Vehicle (See Figure 2). The second configuration was fired March 20 and 21. This was the M32 76mm Cannon mounted in the M76 recoil mechanism which was adapted to fit the ballistic shield of the M551 Vehicle (See Figure 3). The coaxial M73 machine gun was also adapted to this system and was successfully fired (See Figure 4). The third configuration was fired 24 March. This system consisted of an M32 76mm Cannon adapted to the mount for the M81E12 Cannon (See Figures 5, 6, 7, and 8). The fourth system was the XM180 105mm Cannon mounted in the recoil mechanism for the M81E12 Cannon. This system had a semi-automatic breech actuating mechanism and coaxial mount for the M73 machine gun (See Figures 9, 10, 11, and 12).



Figure 2
M103 Cannon Adapted to M81 Mount



Figure 3
M76 Cannon & Mount In M551 Ballistic Shield

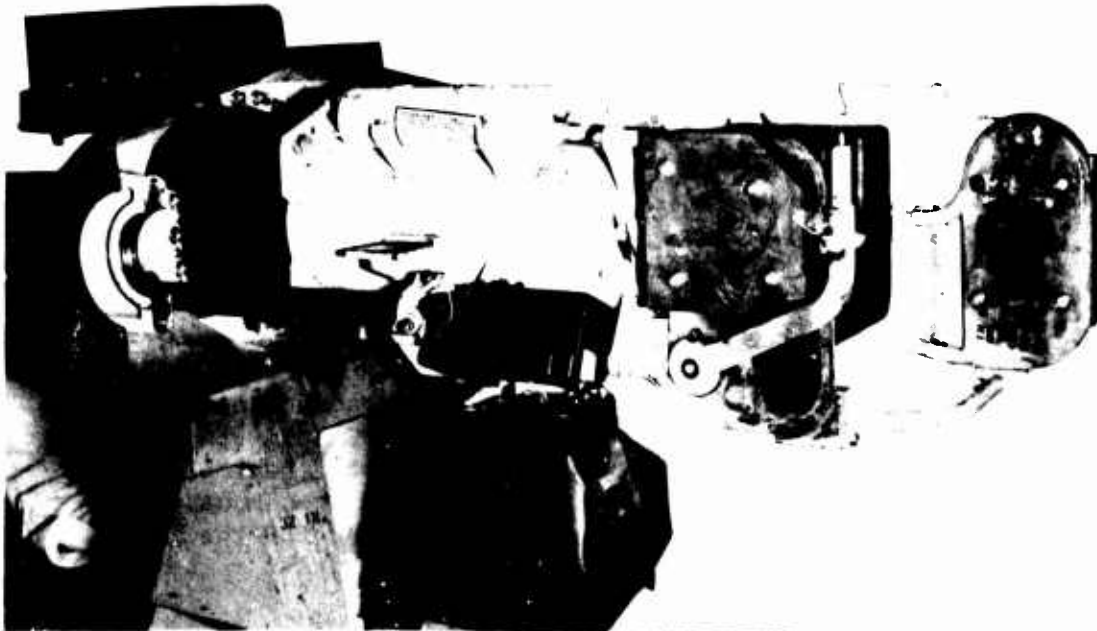

Figure 4
M76 Mount & Cannon With M551 Ballistic Shield & M73
Machine Gun With Brass Catcher

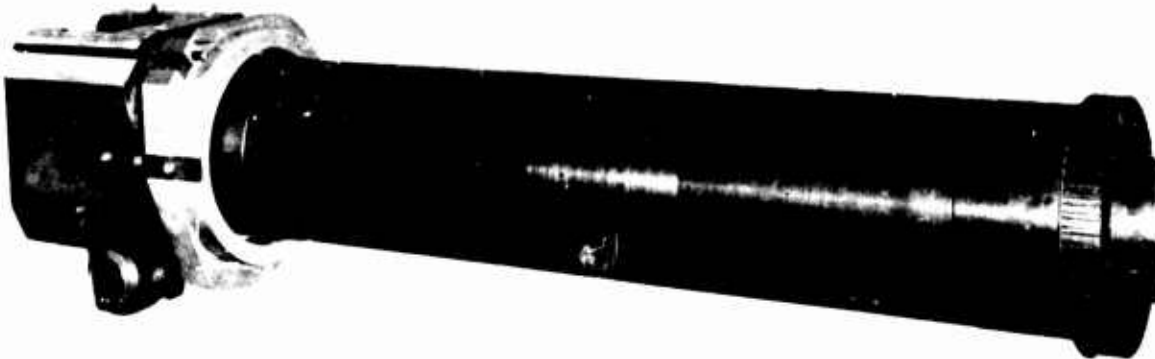

Figure 5
Collar & Sleeve Adapter For The 76mm, M32 Cannon



Figure 6
Adapter & Collar To Mate M32 Cannon With M551 Vehicle

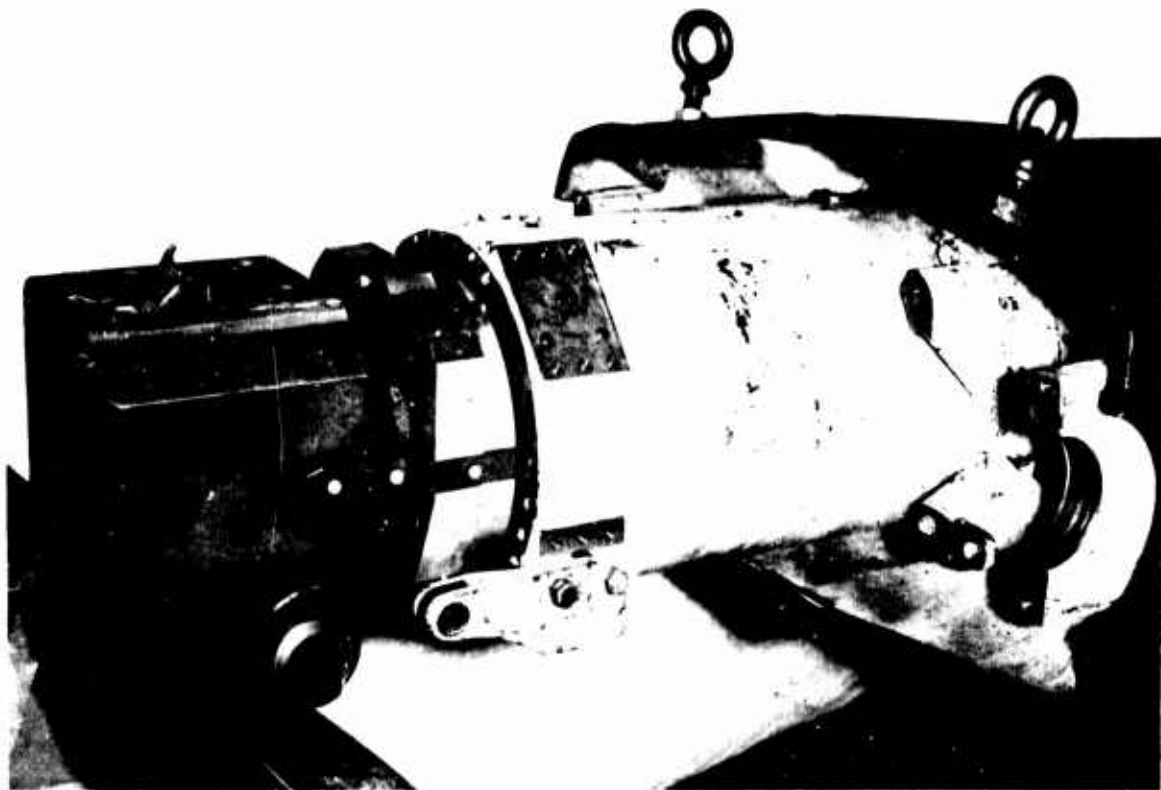

Figure 7
76mm, M32 Cannon Mounted Into The Gun Mount
For The M81E12 Cannon



Figure 8
Breech Block For M32 Cannon
Modified To Clear The Mount For The M81E12

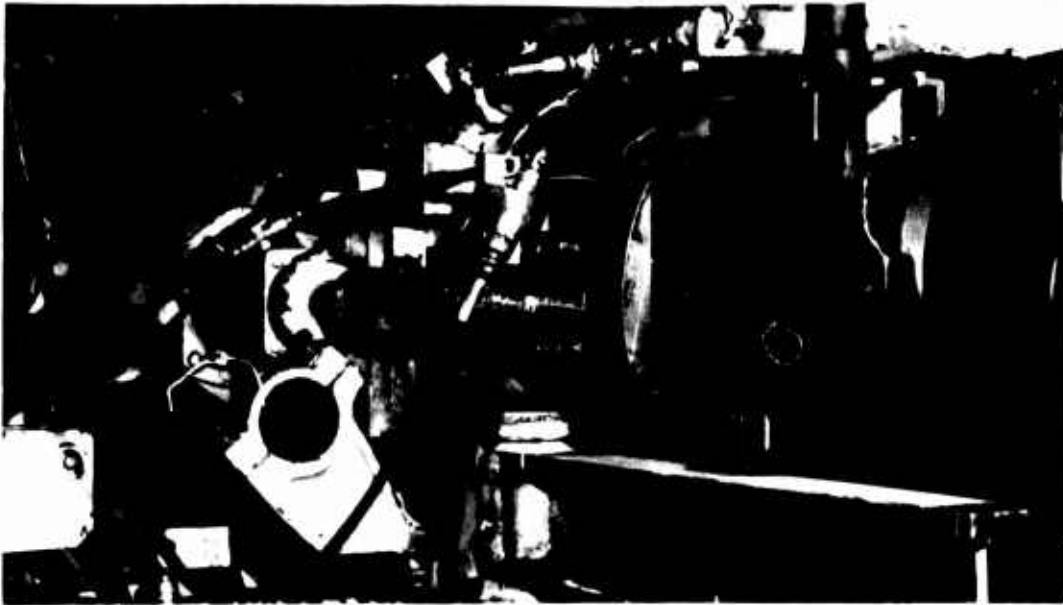

Figure 9
Breech Operating Cam, Cam Bracket, & Buffer Setup
Used With The XM180 Cannon

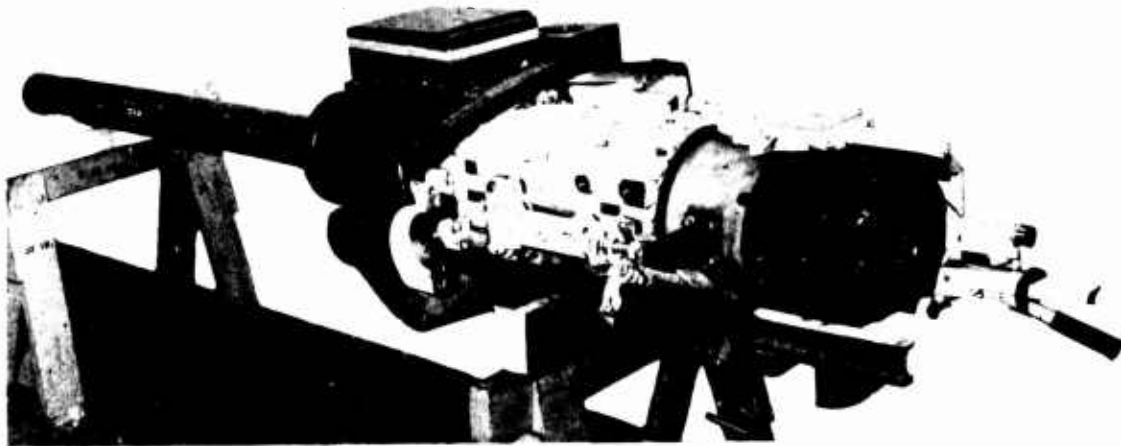

Figure 10
XM180 Cannon In Mount
For The M91E12 Gun Launcher

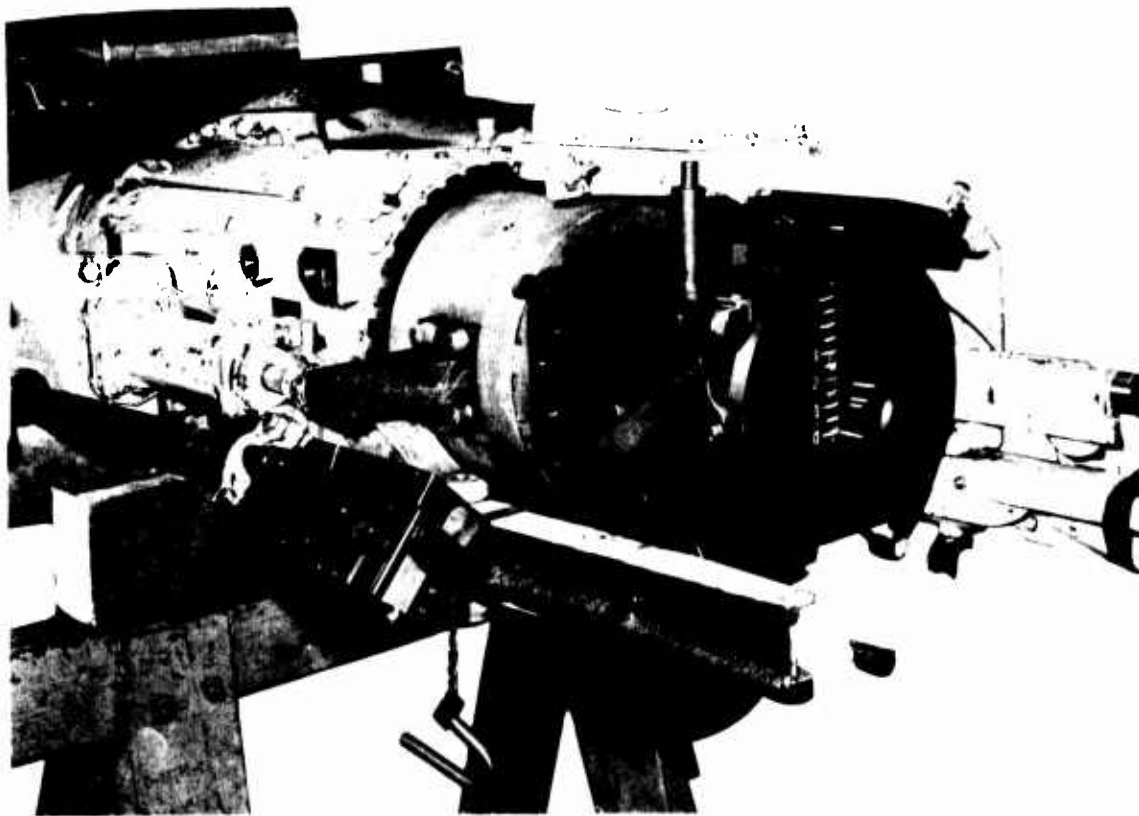

Figure 11
XM180 Configuration For M551 Vehicle

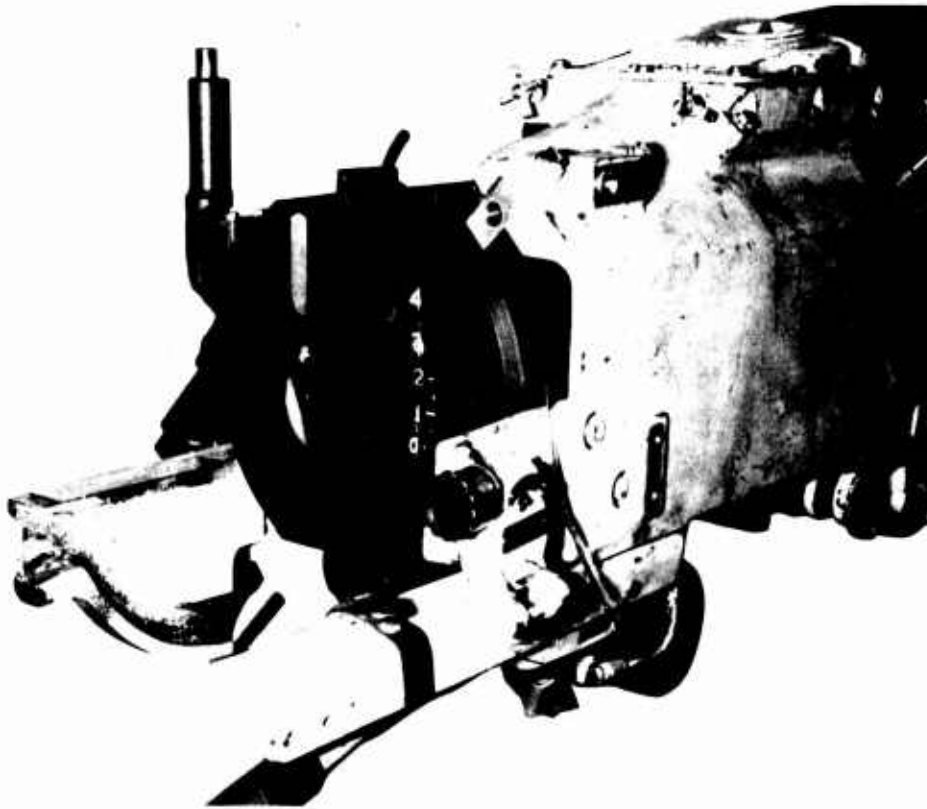

Figure 12
Breech Activating Cam For XM180 System



Figure 13
M103E7 105mm Cannon In M551 Vehicle

Although all systems fired as expected, there will be some changes required before any of them could be used in a tactical situation (See Problem Areas & Solutions in later paragraphs). This report reviews the test data and makes recommendations based on evaluations of this data.

Several gun systems were considered as candidates for alternate armament for the XM551. These were narrowed down to 76mm and 105mm cannons. These were further subdivided into either manual breech opening or semi-automatic breech operation. The four systems and some other systems considered plus supporting activities are tabulated as follows:

1. Mount the 105mm Cannon from the M108 Vehicle in the M551 Vehicle. (Dismissed by AWC before designs were started because the breech cam on the right hand side did not fit in the space).
2. Mount M103 or M137E1 105mm Cannon in M551 (See Figure 13). (This was the first unit completed. It was fired 11 March 1967 using an XM103E7 Cannon that was available at RIA).
3. Mount the 76mm M32 Cannon from the M41 Tank in the M551 Vehicle (See Figure 14).



Figure 14
M32 76mm Cannon In M551 Vehicle

4. Very simple kits have been designed by Rock Island Arsenal to modify existing 152mm ammunition racks to receive either 105mm or 76mm rounds in the M551 Vehicle depending upon which gun is used. This system is reversible in that the original hardware can be replaced and the ammo racks are in servicable condition for the 152mm rounds. This plan is not too desirable as a limited amount of ammunition can be carried. Twenty-three rounds of 105mm ammo was the maximum practical with the kit system.

Other plans were devised so that the maximum amount of ammunition could be carried. There would be no problem getting fifty rounds of 105mm in the vehicle. These plans required that some of the welded-in brackets be cut out and replaced with the new hardware. This system would be better if it were decided that the vehicle would not be reconverted to the 152mm racks again.

Drawings are available of the designs studied by Rock Island Arsenal.

5. Checked to see if the turret on the M41 Tank could be mounted on the M551 Vehicle. (Little time was spent on this before it was decided that Allison Division of General Motors Corporation had studied this portion of the program). Compare Figures 15 and 16.

6. Made computer analysis of each configuration that was fired plus several others that could be considered candidate systems. (See Appendix A).

7. Complete calculations were made on all systems that were fired, plus several other candidate systems. (Results will be summarized in Appendix B).

8. Supplied Watervliet Arsenal with data from the computer studies which applied to Watervliet activities.

9. Besides testing, the Project Manager and AWC were supported by several trips by RIA personnel for report briefings.

10. Photographic and written documentation was made of all activities at RIA on this project. (See references and appendices).



Figure 15
M41 Tank, Front View



Figure 16
M76 Mount & Cannon On M551 Vehicle
(Rear View With Turret Turned 90°)

PROCEDURE

1. The hardware fired 11 March 1967 consisted of the following: (See Figure 17). An adapter sleeve was used to mate the existing gun to the recoil mechanism for the M81E12 Gun. A rifling reaction torque key bracket, buffer bracket, firing mechanism and locking devices were a part of this system. The manufacture of test hardware was expedited by close coordination between the engineers and the prototype shop. Many parts were made from sketches before there was time to make drawings. Component drawings are included on sketch RIA 137132 (See Appendix E). The assembly drawing was RIA 137155. It included the adapter sleeve, the collar, and the torque key bracket as major parts. Minor parts were the triggering mechanism, locking rings, keys, screws, breech operating lug and wrench to fit, buffer bracket, etc. Although 155mm gun barrel stock was being roughed out before drawings were released, it would not be safe to fire without verifying the integrity of the material before it was used. Test samples were sent to the laboratory, and on 3 March a report was received showing that the material was adequate. By this time a complete stress analysis had been completed on all components in the system.



Figure 17
M103E7 105mm Cannon In M551 Vehicle

2. The hardware fired on 20 - 21 March 1967 consisted of the M32 76mm Cannon mounted in the M76 combination mount taken from an M41 Tank (See Figure 18). The assembly drawing was Gun Combination Mount - 67F738. An Adapter (65F655), a Link Assembly (67D716) for elevation and a Bracket (67C740) to hold the standard M73 Machine Gun Mount (K10941850), were the major components. Besides keys, screws, and other small parts, an electrical firing box and cable were manufactured for firing the system. See Figures 19 and 20. A ballistic shield and dust cover (RIA 137167) was designed for this system but not manufactured. (See Appendix E).



Figure 18
M76 Cannon & Mount In M551 Vehicle

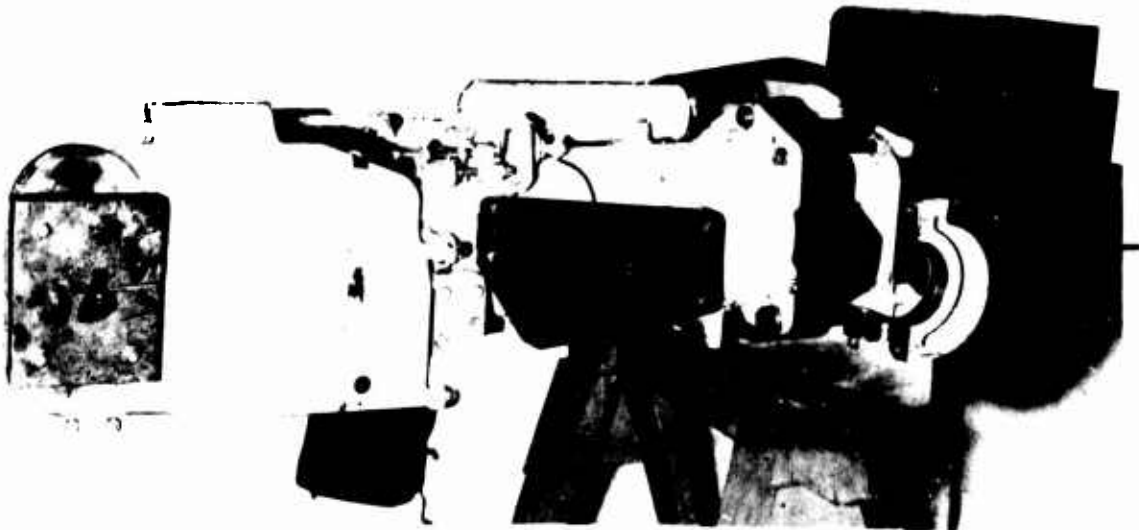

Figure 19
M76 Mount & Cannon In M551 Shield
Showing Adapter & Elevating Link



Figure 20
M76 Mount Showing M73 Machine Gun Mount

3. The hardware fired on 24 March was the M32 76mm Cannon adapted to the mount for the M81E12 Cannon (See Figures 21, 22, and 23). This system required that a corner be machined from the breech ring so that the block would clear the rifling reaction torque key bracket on the mount in the M551. The Adapter Assembly (RIA 137152) included Collar (67F741), Adapter (67K658), two Keys (67B711), Collar (67F671), Key (67B746), Breech Ring Modification (67C719), Buffer Bracket Assembly (67C734), Nut (67B735), Bushing (67B1021), Firing Plunger Assembly (67B789), and various other small parts such as screws, keys, locks, etc.

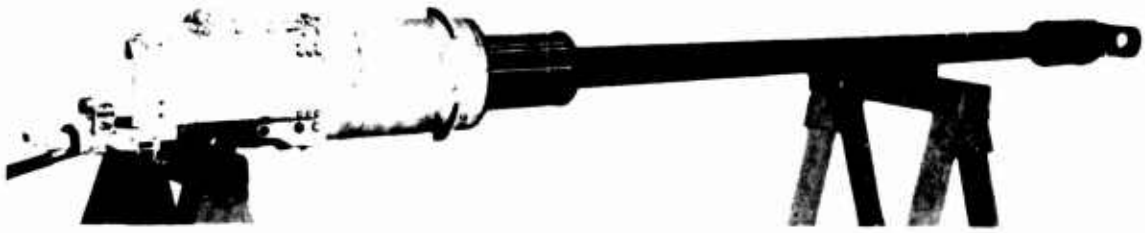

Figure 21
76mm, M32 Cannon In Mount For M81E12 Gun



Figure 22
M32 Cannon Ready For Mounting Into The M551 Vehicle

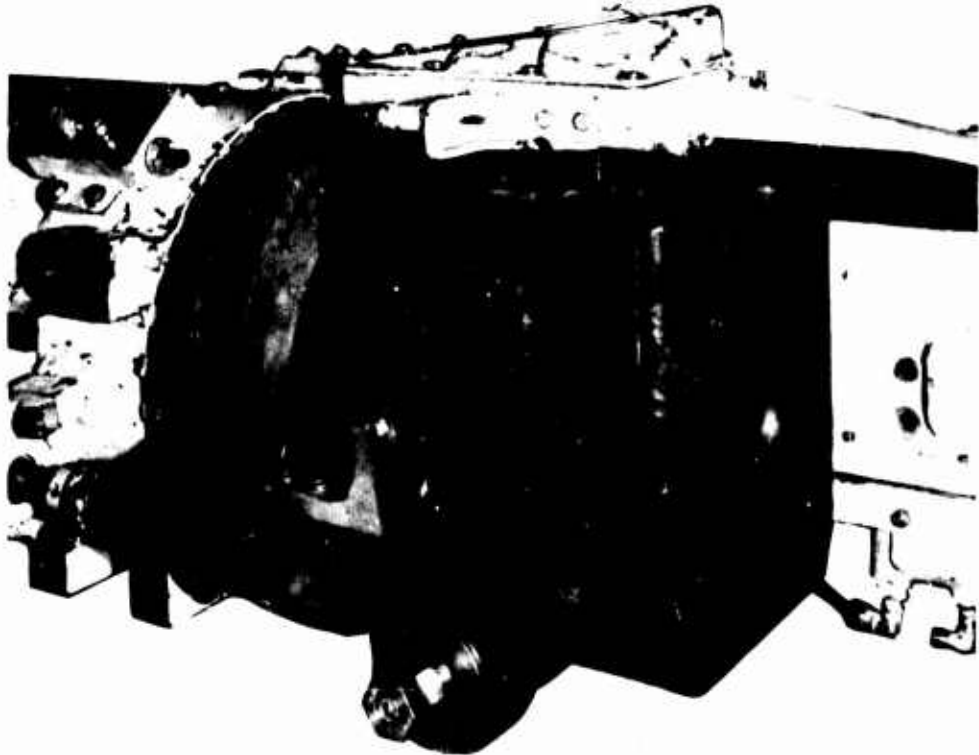

Figure 23
M32 Cannon Mounted In Recoil Mechanism
For The M81E12 Cannon

4. The hardware fired on 1 and 3 April 1967 was the 105mm XM180 Cannon furnished by Watervliet Arsenal with the breech operating handle modified by Rock Island Arsenal so that it would clear the breech actuating cam (See Figures 24, 25, 26, and 27). The XM180 Adapter Assembly (67F885) consisted of Adapter (67D768), Collar (67D791), Plate (67C1030), Wiper (67C881), Retainer (67C880), Collar Assembly (67D808), Bracket Assembly (67F912), Pin (67B998), Lever Assembly (67F1026), Cam Assembly (67D934) (See Figure 28), Stop Assembly (67C1017), Retainer (67A1028), Key (67A882), and assorted screws and triggering hardware.



Figure 24
XM180 Cannon With Sleeve & Collar For Adapting
To M551 Vehicle

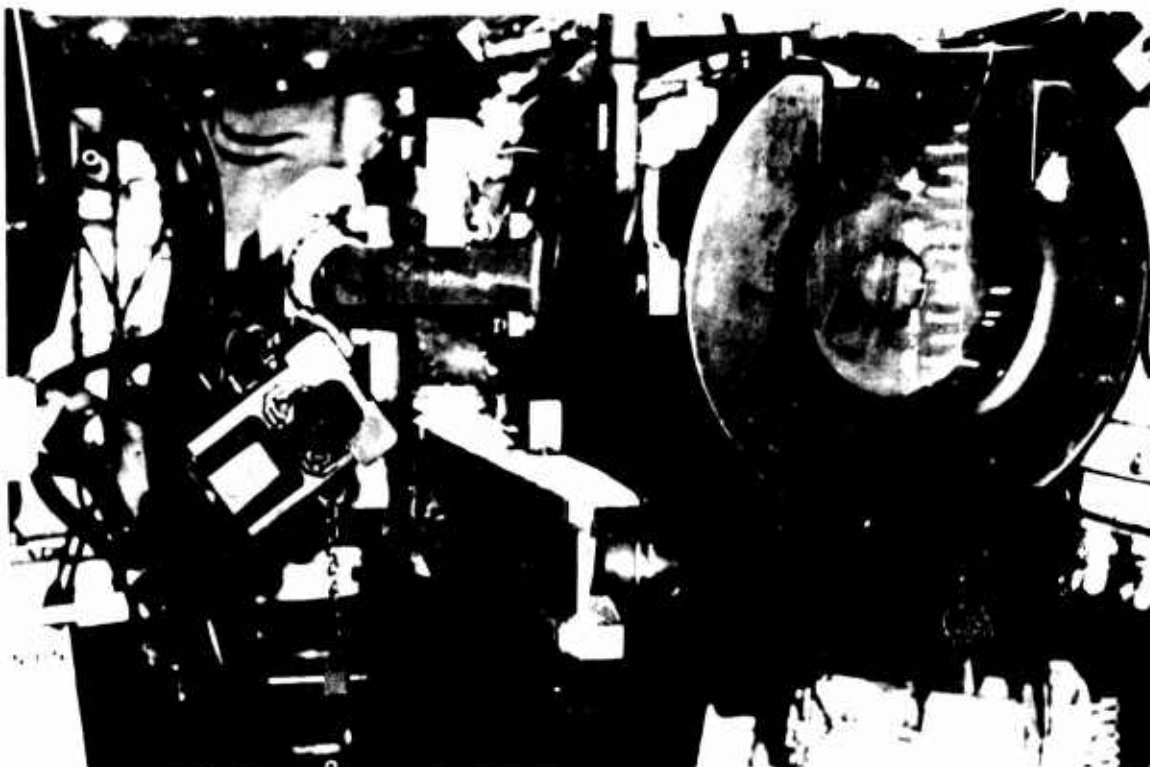

Figure 25
Breech Block Marked For Velocity Of Motion
Due To Cam Action

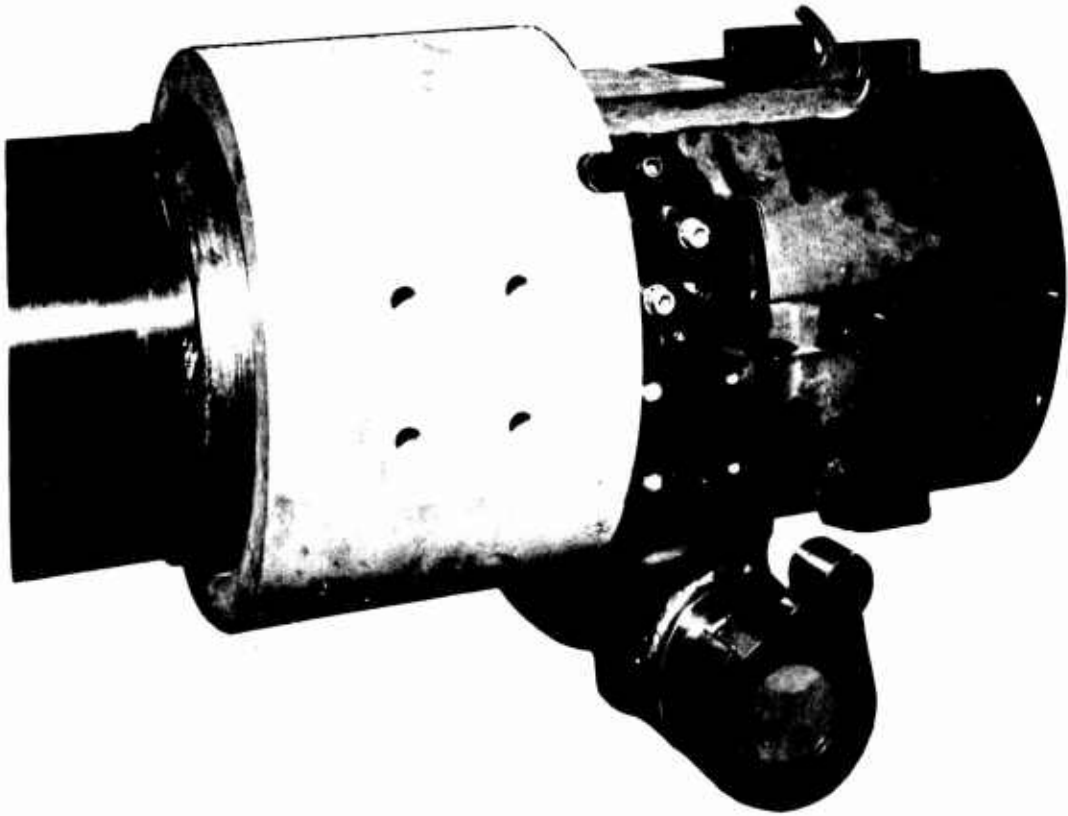

Figure 26
XM180 Cannon In Adapter & Collar With Breech Handle Removed

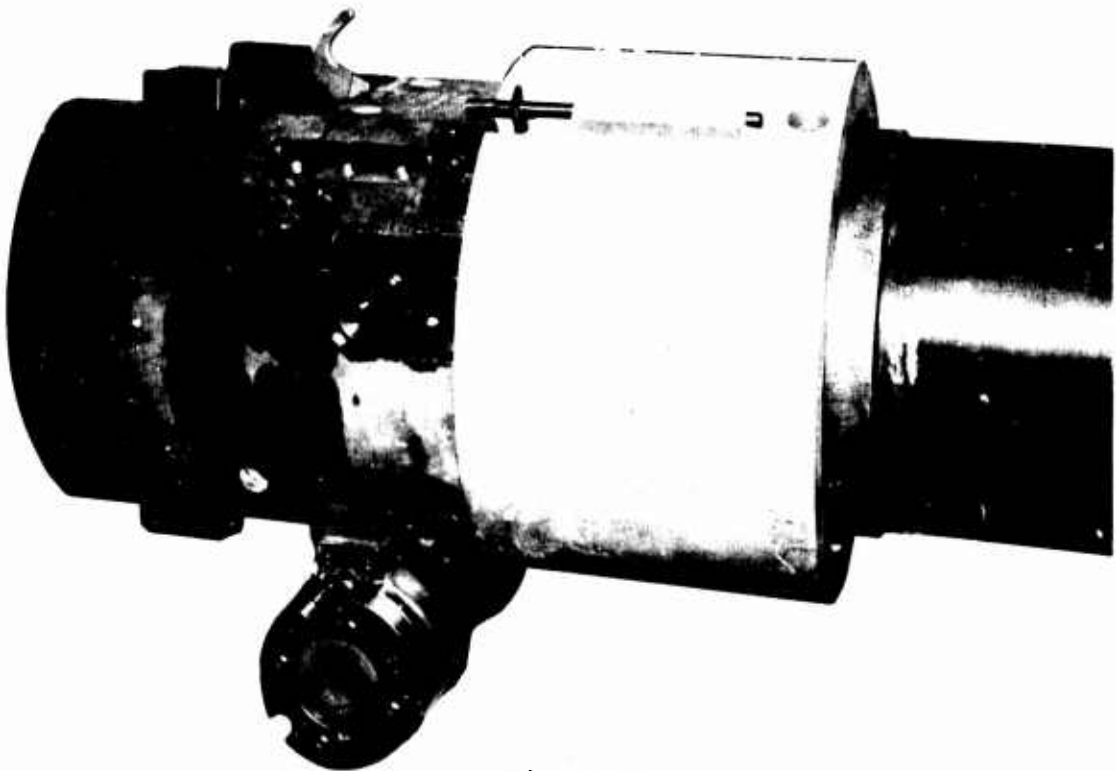

Figure 27
XM180 Cannon With Adapter & Collar For M551 Vehicle

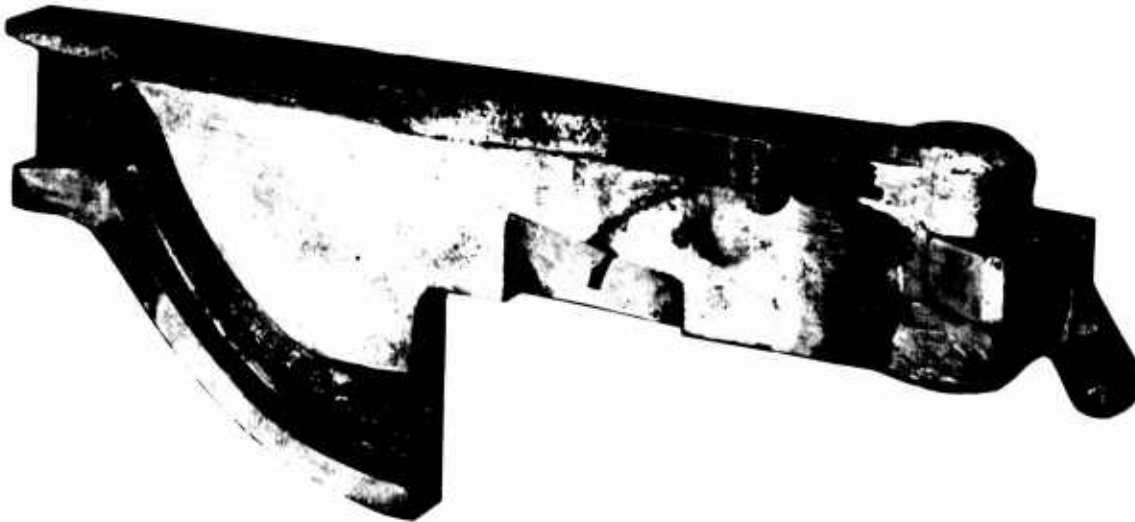

Figure 28
Breech Activating Cam For XM180 Cannon

SUPPORTING WORK

1. Computer programs were being run at the same time hardware was being designed and manufactured. Basic results are included in this report as Appendix A. A technical note is being written that contains all of the work completed. The loads due to the internal ballistics of the different guns and ammunitions fired were applied to the recoil mechanisms parameters in the computer. Instrumentation was designed using the results of the computer studies for each configuration fired. The recoil and counterrecoil velocities were computed so that energy required to operate the breech actuating cam could be calculated. The breech operating cam was designed based on these studies.

The computer was also used to check the feasibility of using the 76mm M32 Cannon to fire a 105mm round after modifying the tube and breech. The M76 recoil mechanism would work well in this environment.

An Oscar data reduction machine was used to reduce instrumentation to a usable form. A summation of computer results and curves made from computer output are in Appendix A.

2. Instrumentation:

Adapting instrumentation to each configuration fired was in process in some cases even before all of the hardware was completed. By the time the assemblies were ready to fire at the proving ground only last minute checks and calibrations were required before the tests started. This saved much valuable time.

3. Calculations:

Stress analysis, weights, and centers of gravity were calculated on components. The results were checked with the actual hardware as it was completed. Particular attention was paid to the unbalanced torque of an entire system in the actual configuration fired. A summation of the results of the calculations is in Appendix B.

PROBLEM AREAS AND SOLUTIONS

Other than problems of getting forging stock on such short notice, there were no fabricating problems. Scrap 155mm gun tubes were used to solve the forging problem.

The major problems stem from the limited space in the turret and the unbalance of the systems that were fired. All interferences and unbalance situations were measured and photographed. A resume of these conditions follows:

Figures 29, 30, and 31 show the area of interference between the breeches and the elevating system.

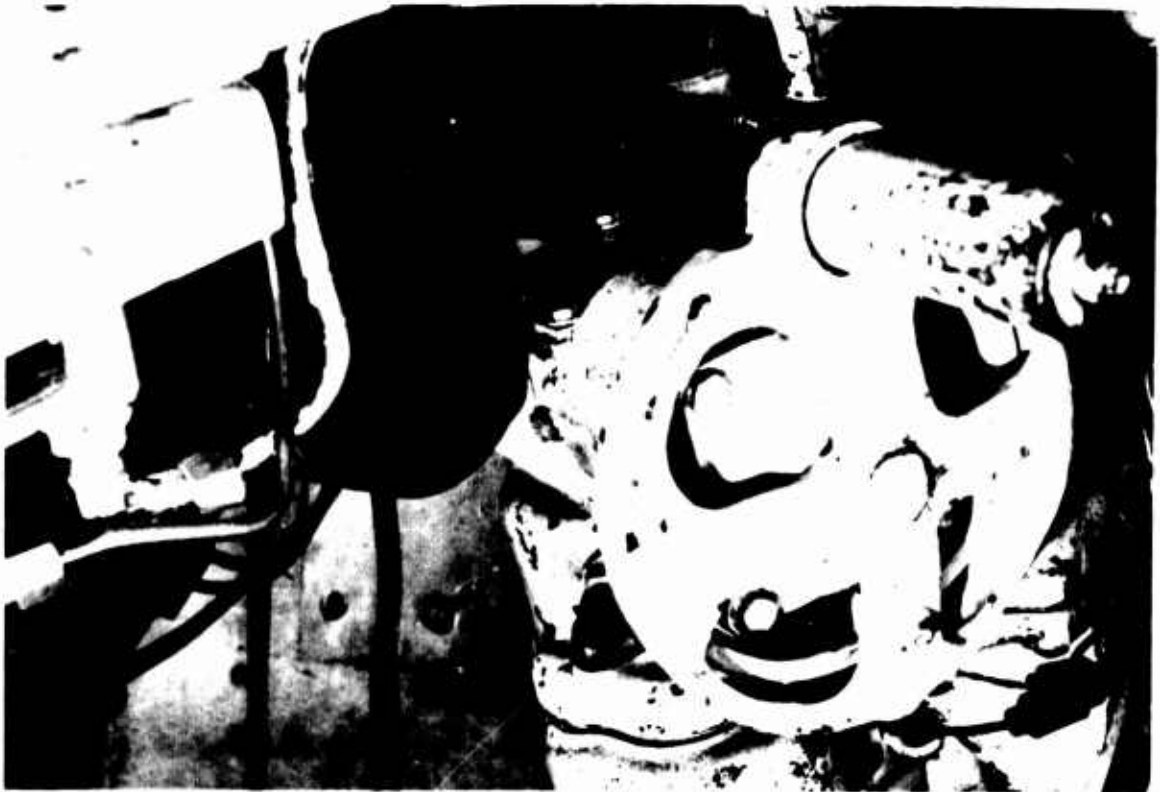

Figure 29
Interference at 259 Mils Q.E.,
With The Breech On The XM180 Cannon



Figure 30
Elevating Link, M551 Vehicle

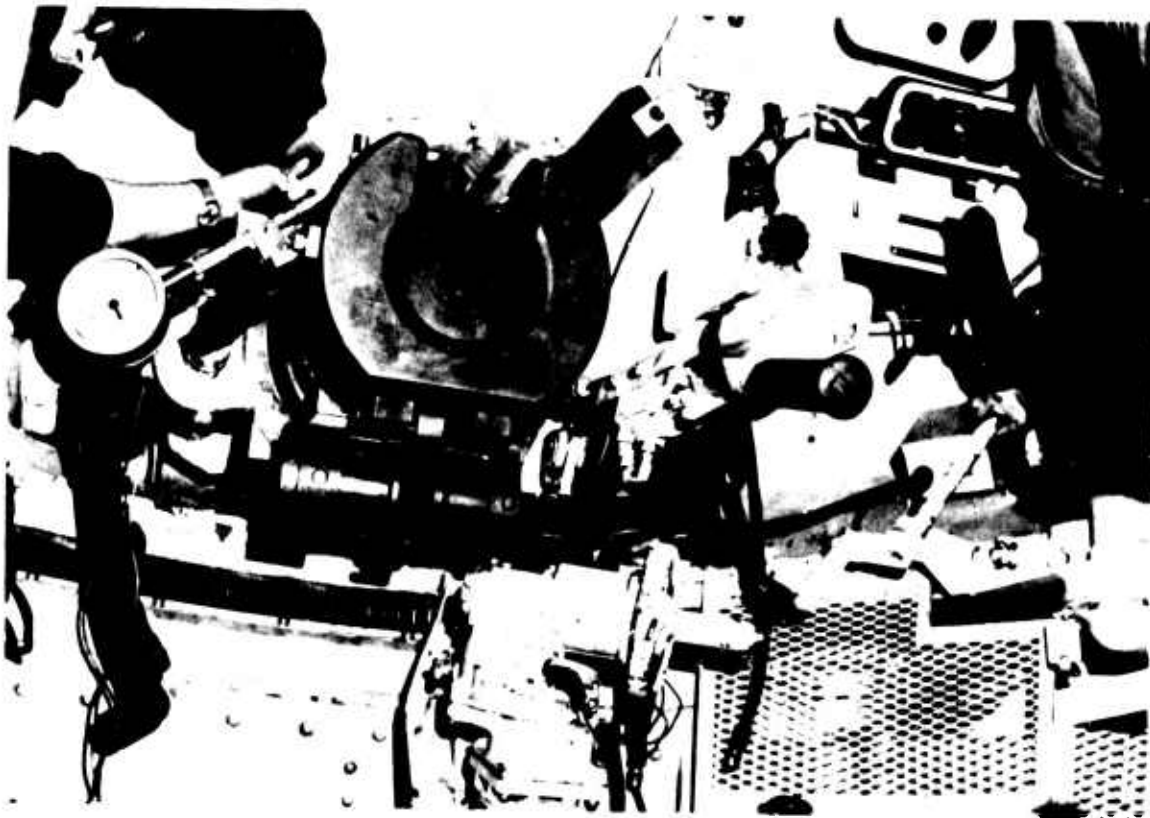

Figure 31
Interference of Breech on XM103E7 Cannon With
Elevating Mechanism Housing
18

The different configurations elevated to different angles, but the basic problem was the same (See Appendix B). There are several ways to solve this interference problem:

1. Move the breech crank bracket two inches to the left. The left side would have to remain in the same location so the breech block spring would have to be shortened.

2. Move the hole forward in the bracket shown in Figure 30. This would move the whole elevating mechanism forward far enough to clear the breech. This reduces the lever arm but with a balanced system this should be no problem.

3. Modify the elevating mechanism casting so that it clears.

4. A combination of the above may solve the problem.

The M73 machine gun can be used with all four systems fired. However, to get proper elimination of the spent brass and links, the M73 gun was turned at an angle of forty-five degrees when using the XM180 gun. In this position the catcher bag can be hung below the gun directly instead of the chute required in the present M551 configurations. No problems with feeding, firing, or servicing were encountered in this position. When mounting the M73 machine gun with the M76 mount, a slight angle was required to use the standard chute and bag for the spent brass and links (See Figure 4).

The longer barrels on the M32 and M103 Cannons will interfere with the swimming kit on the vehicle unless the gun is elevated (See Figures 32, 33, and 34). No attempt was made to determine the overall balance of these systems in the water as the overall floating center of gravity could be changed by many factors beyond the scope of the primary armament itself. Even though the primary armament is unbalanced around its own trunnion, the vehicle could be rebalanced by the position of the ammunition storage and other considerations. Pending a decision on a new primary armament, this determination could not be made.

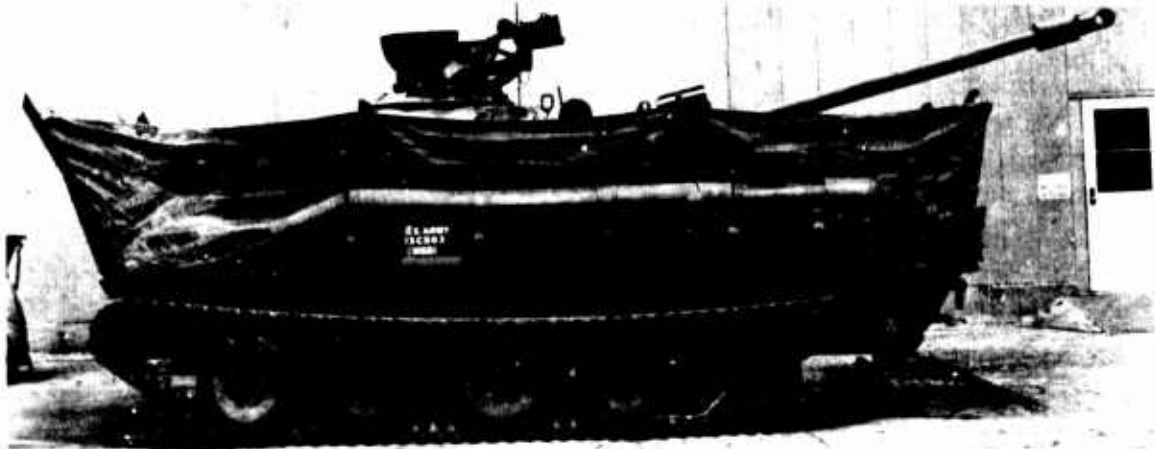

Figure 32
M76 Mount & Cannon In M551 Vehicle, Swim Curtains Up
With Cannon Pointing To Rear & At Max. Q.E. (219 Mils)

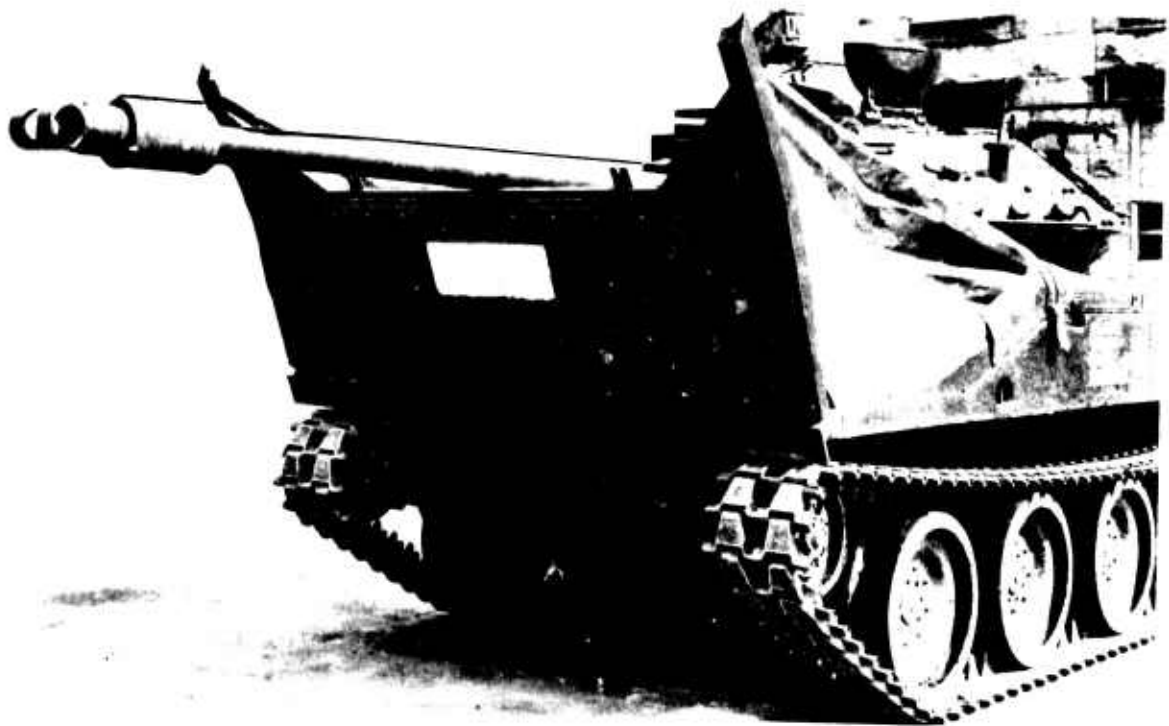

Figure 33
M76 Mount & Cannon In M551 Vehicle,
Half Surfboard Up & Cannon at 34 Mils Q.E.

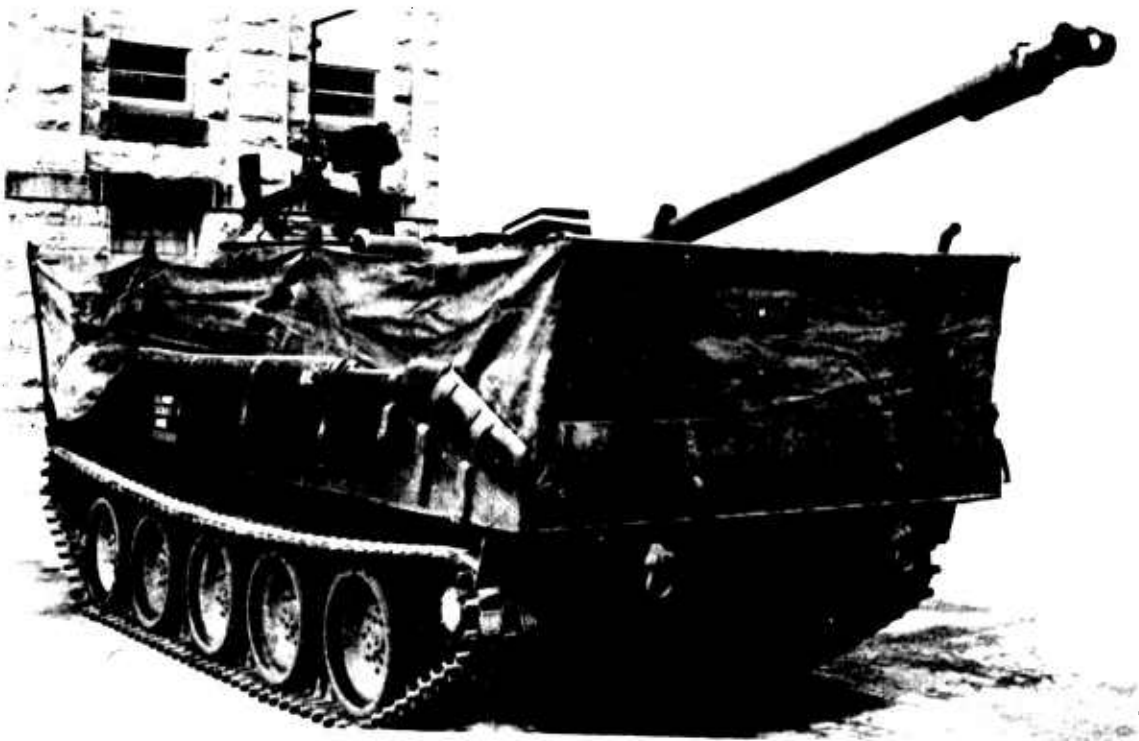

Figure 34
M76 Mount & Cannon In M551 Vehicle
Rear View Showing Swim Curtains Up & Cannon at Max Q.E. (240 Mils)

With the gun resting on the surfboard as shown in Figure 33, the Q.E. was 34.1 mils. With the gate up, the Q.E. was 211 mils. At the maximum Q.E. of 240 mils, the gun barrel cleared the surfboard by eight inches (See Figure 34).

Some problems were encountered with the recoil mechanism for the M81E12 Cannon. Instrumentation indicated a fall-off of recoil oil pressure after each shot. This was more pronounced while firing the TPM340E1 Projectile. On the low zones of the 105mm it was not apparent. Several reasons could account for this fall-off of pressure. An oil leak, belleville springs taking a permanent set, or excessive friction in the piston area ahead of the spring pack could cause reduced pressure under firing conditions. Between the 21 March shoot and the 24 March shoot, the recoil mechanism was checked and new "O" rings were required on the piston. This did not seem to be the total problem, however, because on the 24 March and 1 - 3 April shoots the pressure still fell off after each round. If the mechanism was precharged to 850 psi between each round, the pressure would drop to approximately 750 psi. If the mechanism was fired at 750 psi prepressure, it seemed to hold there. The mechanism was not torn down after the firing program was complete so the reason for the loss of pressure was not determined. The system being fired was a unit with an older style piston ring in it as well as older model belleville spring packs. As the test was not being run to evaluate the existing recoil mechanism, no further evaluations were made.

On the XM180 system, the breech operating cam failed to operate the mechanism on two of twelve rounds. Fastex movies of the area in question indicated that the cam was bouncing during operation. On these two rounds, the cam bounced out of reach of the crank. A stronger spring and a buffer on the cam arm would solve this problem.

HARDWARE

The following hardware was assembled at Rock Island Arsenal for this five week program:

1. M108 Vehicle

It was first thought that the gun from this system would be adapted to the M551. We used the breech operating cam from this vehicle for design work until drawings were available.

2. Two M41 Tanks

The guns and one of the M76 recoil mechanisms were used from these vehicles.

3. M551 Vehicle borrowed from AWC. This is the vehicle that all the configurations were fired from.
4. XM180 Cannon furnished by Watervliet Arsenal.
5. XM103E7 Cannon available at RIA from the XM104 program.
6. A new Shillelagh Mount from the production line at RIA.
7. Special hardware designed and built for this program. See parts list and assembly drawings in Appendix E.
8. Special brackets for adapting instrumentation.
9. The borrowed hardware was reassembled into its original condition, or better, and returned to the lenders.
10. All other hardware was inspected, tagged, and stored. It is ready for immediate use if a decision is made to use one of the systems fired during this program.

RESULTS

Four hardware systems were successfully fired.

With slight modifications two systems could be made to work well in the M551 Vehicle.

Reduced data from typical firings from each system are found in Appendix D.

All systems performed as predicted based on the computer studies.

With minor refinements, the cam is adequate to open the breech on the XM180 Cannon.

Ammunition racks can be modified to accept smaller caliber rounds by kit without modifying the basic vehicle.

The M73 machine gun fires satisfactorily with either systems that have semi-automatic breech actions. No attempt was made to mount the coaxial M73 on the other two systems.

CONCLUSIONS & RECOMMENDATIONS

The best solution of the systems tested, and the one recommended for use if a 105mm cannon is mounted in the M551 Vehicle is the XM180 system that was fired 1 - 3 April 1967.

Although a kit to stow 105mm and 76mm ammunition in the M551 Vehicle without modifying the original 152mm racks is possible, the best solution is to remove the present racks and replace them with new racks. This makes it possible to carry fifty rounds of 105mm ammunition in the turret.

A spent case catcher may not be required with the 105mm system.

Worn out 155mm gun tubes make adequate forging material from which to machine the adapter sleeves.

APPENDIX A

COMPUTER RESULTS

1. Recoil Mechanism Study

The primary purpose of the computer study was to theoretically predict the dynamic behavior and fluid flow reactions of the M103 Cannon with the M551 Vehicle. The procedure was to: (1) derive the equations of motion (2) compile and compute the necessary input data and (3) write the computer program. Then a number of computer runs were made until an actual M551 firing record was analytically matched (See Graph 1). This was done by varying the discharge coefficient from run to run while holding all other parameters constant. Upon determination of the correct discharge coefficient, the XM81E12 ballistics were replaced with the M103 ballistics and the desired run made. The computer prediction was reasonably close to the test firing which was later conducted (See Graph 2).

The data, computer program, and derivation of the equations of motion will not be listed here but published later in a technical note. However, the equations are listed below in their final form. The derivations were based on the following assumptions: (1) uni-directional flow (2) constant friction (3) compressible flow and (4) constant discharge coefficient.

$$M_R \ddot{x} = B(t) + P_2 A_2 + W_R \sin\alpha - P_1 A_1 - F_R \quad (1)$$

$$M_s \ddot{y} = P_2 A_3 - W_s \sin\alpha - F_s - K(y + y_{st}) \quad (2)$$

$$Q_x = A_x C_x \sqrt{\frac{2g}{\sigma} (P_1 - P_2)} \quad (3)$$

$$\frac{d P_1}{dt} = \beta_1 \left[\frac{A_1 \dot{x} - Q_x}{A_1 (L - x)} \right] \quad \text{or} \quad P_1 = (P_1)_0 + \beta_1 \int \frac{A_1 \dot{x} - Q_x}{A_1 (L - x)} dt \quad (4)$$

$$\frac{d P_2}{dt} = \beta_2 \left[\frac{Q_x - A_3 \dot{y} - A_2 \dot{x}}{V_0 + A_3 y + A_2 x} \right] \quad \text{or} \quad P_2 = (P_2)_0 + \beta_2 \int \frac{Q_x - A_3 \dot{y} - A_2 \dot{x}}{V_0 + A_3 y + A_2 x} dt \quad (5)$$

Where	M_R	=	Mass of the recoiling parts
	x	=	Recoil displacement
	\dot{x}	=	Recoiling parts velocity
	\ddot{x}	=	Acceleration of the recoiling parts
	$B(t)$	=	Breech force-time curve
	W_R	=	Weight of recoiling parts
	α	=	Angle of elevation
	F_R	=	Guide and seal friction
	M_S	=	Mass of the belleville spring pack
	y	=	Spring pack displacement
	\dot{y}	=	Velocity of the spring pack
	\ddot{y}	=	Acceleration of the spring pack
	W_S	=	Weight of the spring
	F_S	=	Spring friction
	K	=	Spring rate
	Y_{ST}	=	Static position of the spring
	A_X	=	Orifice area-displacement curve
	C_X	=	Discharge coefficient
	β_1 & β_2	=	Effective bulk moduli of the oil
	V_O	=	Volume available for oil
	L	=	Effective length of the fluid column
	A_1, A_2 & A_3	=	Areas as shown on Figure 1
	S	=	Acceleration of gravity
	σ	=	Density of the oil
	$(P_1)_0$	=	Initial pressure on P_1
	$(P_2)_0$	=	Initial pressure on P_2

COMPARISON OF THEORETICAL VS EXPERIMENTAL
FOR AMBULANCE CANNON WITH MISSILE
DISCHARGE COEFFICIENT = .95

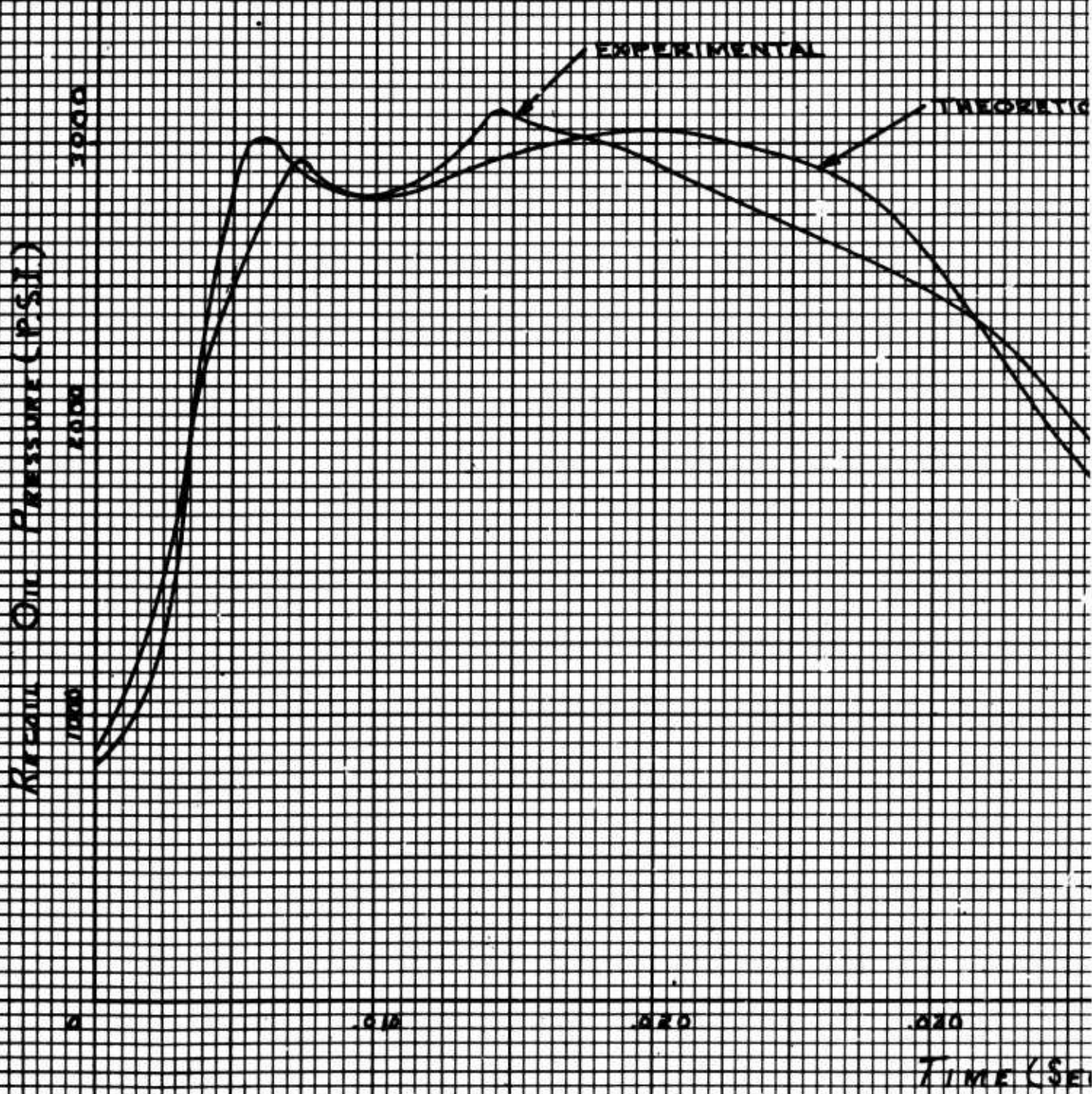

THEORETICAL VS EXPERIMENTAL FIRING
WITH MISSI VEHICLE

EFFICIENCY .95

THEORETICAL

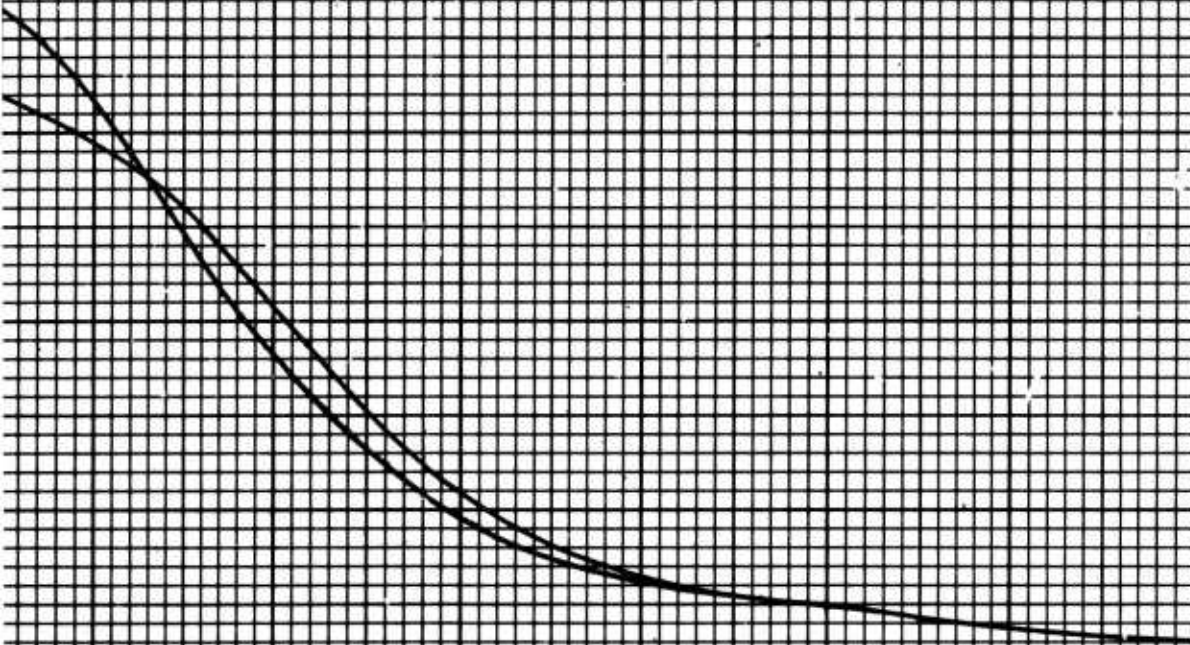

.020

.040

.060

.070

TIME (SEC)

2

GRAPH 1

COMPARISON OF THEORETICAL
FOR M103 CANNON WITH
DISCHARGE COEFFICIENT

MECHANICAL PRESSURE (PSI)

2000

1000

0

0.010

0.020

0.030

0.040

0.050

0.060

0.070

TIME (SEC)

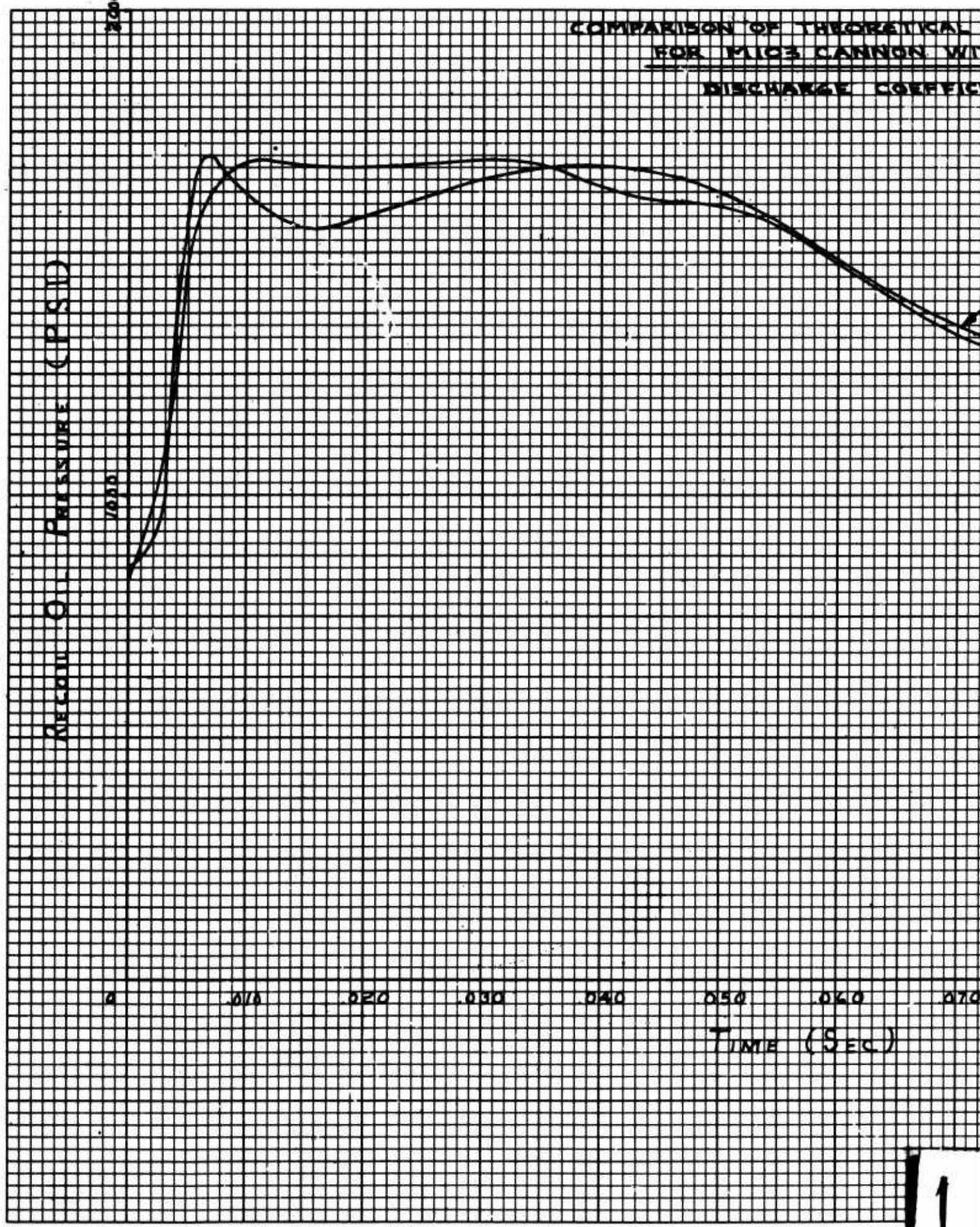

1

THEORETICAL VS EXPERIMENTAL FIRING
3 CANNON WITH M551 VEHICLE
RANGE COEFFICIENT = .85

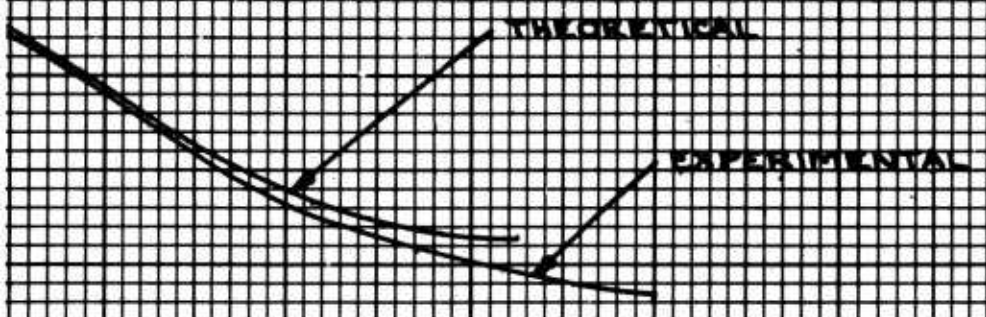

0.60 0.70 0.80 0.90
(SEC)

2

GRAPH 2

2. Cam Study

The counterrecoil time and motion study was required to see if there was enough energy stored in the system to actuate the breech operations through a cam. The cam on the XM180 system was designed based on the following curves. These curves are the result of a computer study using the equation of motion which follow. Some of the input parameters were taken from instrumented data from the 11 March shoot.

The equation of motion for counterrecoil in its final form:

$$\left[M_R + M_S \left(\frac{A_1 - A_2}{A_3} \right)^2 \right] \ddot{x} = - K_x \left(\frac{A_1 - A_2}{A_3} \right)^2 - (A_1 - A_2) P_{2(o)} + W_R \sin \omega t + F_R + A_1 \frac{\sigma}{2g} \dot{x}^2 \left(\frac{A_1}{C_x A_x} \right)^2 + A_{RB} P_B$$

Where $A_{RB} P_{RB}$ is equal to the external buffer force

$$P_2 = M_S \left(\frac{A_1 - A_2}{A_3} \right)^2 \ddot{x} + K_x \left(\frac{A_1 - A_2}{A_3} \right)^2 + P_{2(o)}$$

$$P_1 = P_2 - \frac{\sigma}{2g} \dot{x}^2 \left(\frac{A_1}{C_x A_x} \right)^2$$

$$P_B = \frac{\sigma}{2g} \dot{x}^2 \left(\frac{A_{RB}}{C_B A_B} \right)^2$$

The buffer force comes on at 3 inches out of battery.

Graphs 3 and 4 are the results of the counterrecoil study.

COUNTER RECOIL VELOCITY (IN/ SEC)

-100 -200 -300 -400 -500 -600 -700

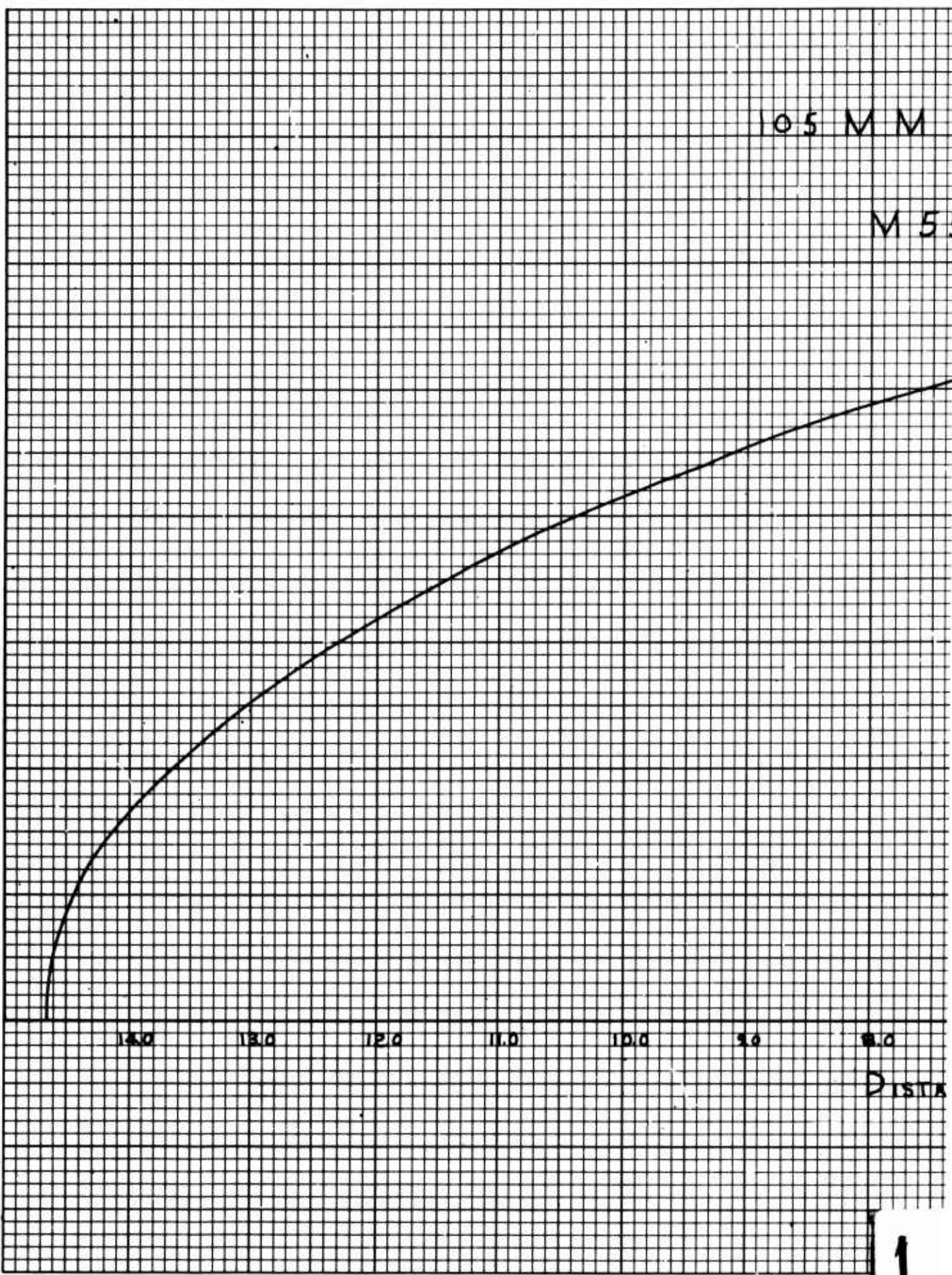

1

5 M M M103 CANNON
IN
M551 VEHICLE

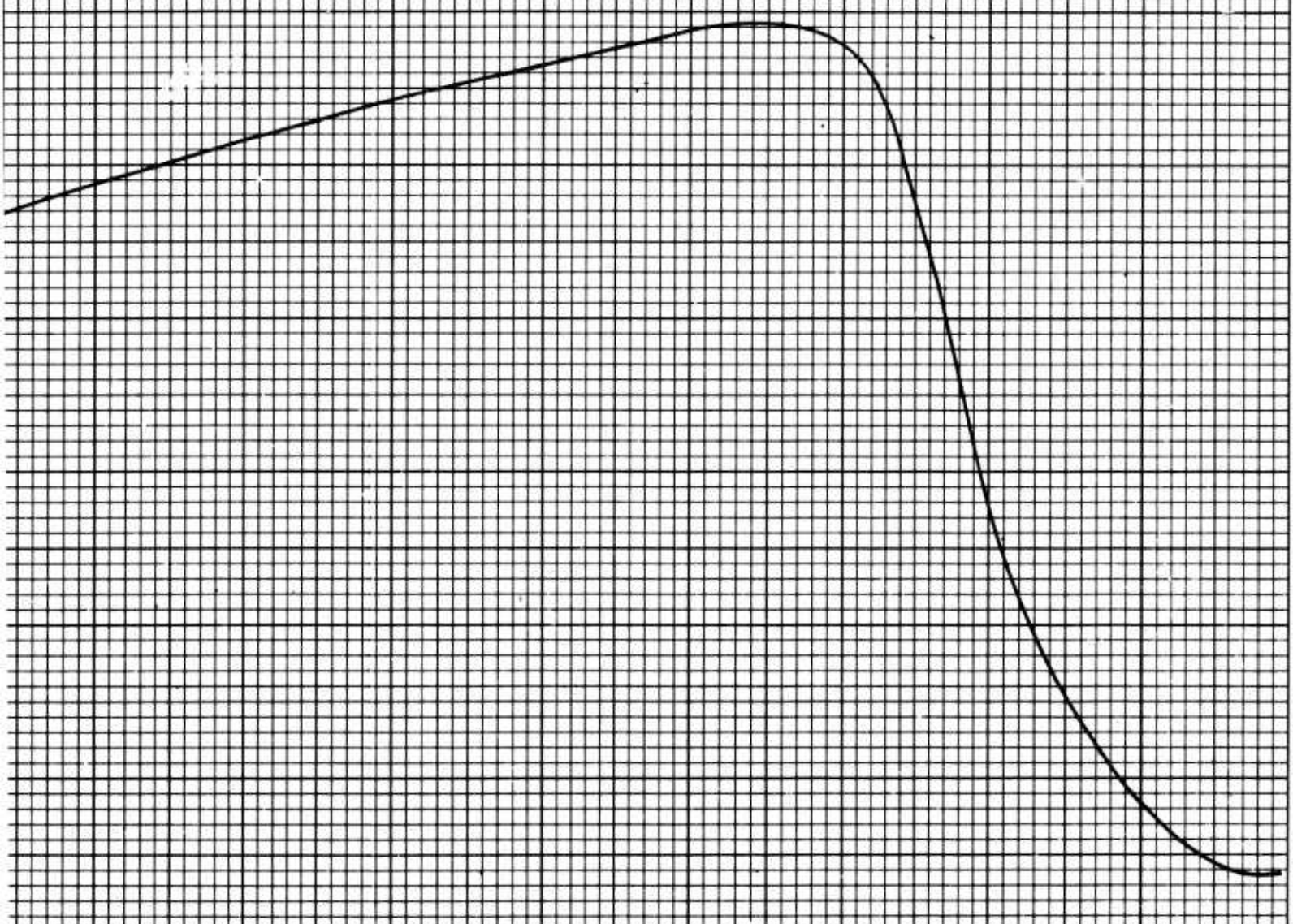

80 70 60 50 40 30 20 10
DISTANCE (IN)

2

GRAPH 3

COUNTER RECOIL VELOCITY (IN/SEC)

0 -10.0 -20.0 -30.0 -40.0 -50.0 -60.0

0

100

150

200

250

300

350

TIME

1

10

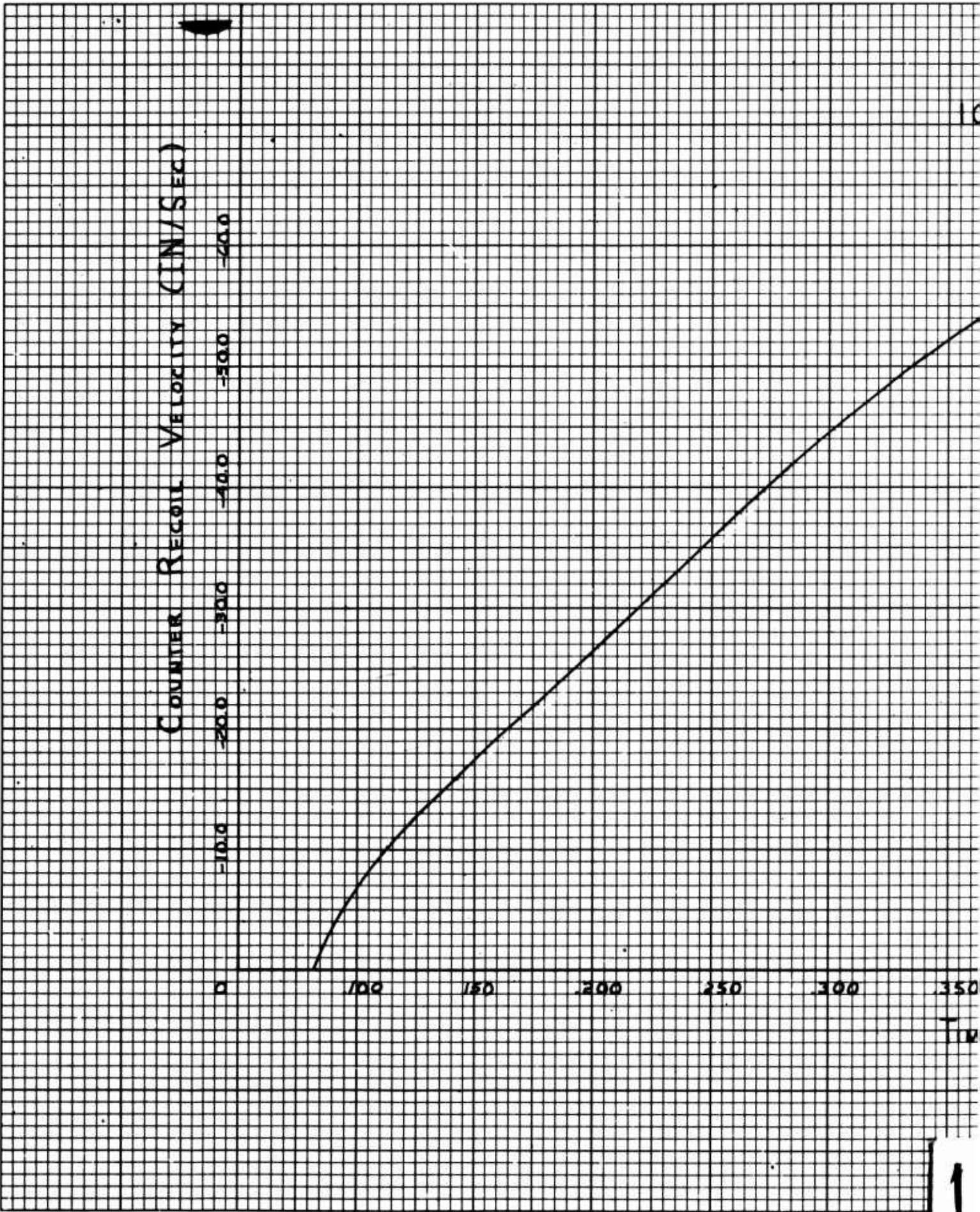

105 MM M103 CANNON
IN
M551 VEHICLE

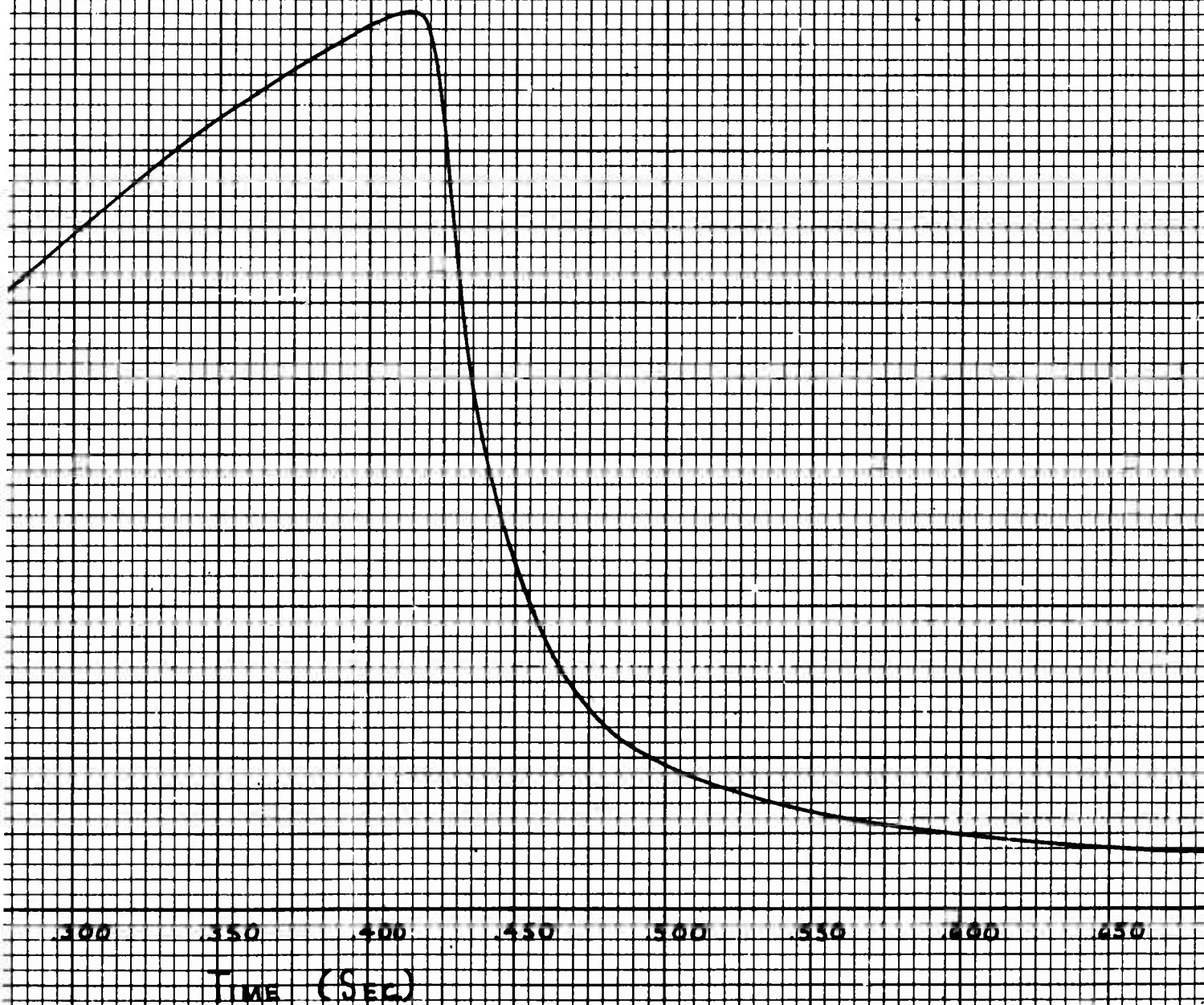

2

GRAPH 4

APPENDIX B
SUMMATION OF CALCULATIONS

Table I - Tabulation of Systems

System	Weight (lbs)	Unbalance (in-lbs)	Type of Breech	Bore Evacuator	Muzzle Brake	Date Fired
M103E7 Cannon in M551 Mount	2750	9780 Muzzle Heavy (Measured)	Manual	No	No	11 Mar 67
XM180 Cannon in M551 Mount	2769	3700 Muzzle Heavy (Measured)	Semi-Automatic	No	No	1-3 Apr 67
M32 Cannon in M76 Mount	2993	13000 Muzzle Heavy (Measured)	Semi-Automatic	Yes	Yes	20-21 Mar 67
M32 Cannon & Mount Modified to 105mm	2673	9890 Breech Heavy	Semi-Automatic	Yes	No	Not Fired
M32 Cannon & M76 Mount, Gun Tube 30 in. shorter	2683	6660 Muzzle Heavy	Semi-Automatic	Yes	No	Not Fired
M32 Cannon in Mount For The M81E12 Cannon	3097	42,560 Muzzle Heavy	Manual	Yes	Yes	24 Mar 67
*M32 Cannon in M551 Mount Gun 40 in. shorter	2985	14,280 Muzzle Heavy	Manual	Yes	No	Not Fired

*NOTE: Cannon also set back 4.0 in. farther into turret

For the first firing (11 March 1967) of a 105mm cannon in the M551 Vehicle, the following components were used:

1. M103E7 Cannon - had threads for a muzzle brake - 852 lb and C.G. was 38.8 in. ahead of rear face of the breech ring.
2. Mount for the M81E12 Cannon in the M551 Vehicle - experimental unbalance of 3230 in. lb. standard Shillelagh configuration.
3. Adapter - M103 Cannon to M551 Mount.

After these parts were assembled and mounted into the M551 Vehicle, the total unbalance (in-lb) around the trunnions was found by setting the end of the gun tube on a scale, taking this weight and multiplying it by the distance to the C of the trunnions. This unbalance was 9900 in. lb.

The maximum unbalance limit around the trunnions was 6000 in. lb. This was based on the elevating mechanism limitations and was quoted by the prime contractor for the system. To get this without actually hanging weights on the breech, it was decided to set the cannon farther back in the recoil mechanism, which amounts to bringing the C.G. of the cannon closer to the trunnions. The results were as follows:

1. Breech 1 in. behind inner recoil sleeve - (First model)
Unbalance = 9900 in. lb.
2. *Breech 4 in. back. Unbalance = 6058 in. lb.
3. *Breech 6 in. back. Unbalance = 3285 in. lb.
4. *Breech 6.5 in. back. Unbalance = 2690 in. lb.

When the first mechanism (M103E7 Cannon) was in the turret it was checked for clearance in the turret and elevation interference. At 160 mils Q.E. the crank bracket on the bottom of the breech interfered with the handwheel elevation housing. Clearance for full elevation was actually gained by jacking the cannon out of battery until the crank bracket cleared the elevation housing.

<u>Cannon (In, Out Of Battery)</u>	<u>Max. Elev. Obtained</u>
3 inches	192 mils
5 "	250
5.5 "	323

*NOTE: Calculated using XM180 Cannon

At 323 mils the elevating mechanism itself bottomed. At minimum Q.E. (-73 mils)(over back of vehicle) for 5.5 in. out of battery, there was 5.0 inches clearance to the top of the turret from the top of the breech, assuming a maximum recoil of 15 in. Also at this distance out of battery there was suitable room left for loading. Since the cannon was already set one in. back in the recoil sleeve, it was decided to set the cannon 6.5 in. (1. + 5.5) back in the recoil sleeve to eliminate all clearance problems, and at the same time help any unbalance problem.

From these facts the system fired on 1 - 3 April 1967 was designed.

XM180 Cannon - new model M103 Cannon, no muzzle brake, breech handle and cam for semi-automatic breech on the left side, weight = 890 lb, C.G. 39.0 forward of the rear face breech ring. Adapter weight 168 lb.

After the XM180 Cannon was mounted in the turret of the M551 Vehicle, the following data was taken.

ELEVATION & DEPRESSION

1. Cannon to Rear Vehicle

Maximum elevation 164 mils before the brackets on the bottom of breech struck handwheel housing. Maximum depression -73 mils, stopped by safety stop on ballistic shield.

2. Cannon to Front Vehicle

Maximum elevation same as to the rear of vehicle. Maximum depression -125 mils, the breech handle interferes with the top of the turret. If the handle is removed, 155 mils depression is achieved.

The total weight of the assembly around the trunnions, including machine gun (M73) is 2769 lb. The measured unbalance is 39 lb @ 95 in = 3700 in-lb muzzle heavy. In the preliminary study wt = 2627 lb and unbalance = 3980 in-lb muzzle heavy. The difference in the two accounted for by the addition of a machine gun and cam and mounting brackets, to the test model, which were not accounted for in the preliminary calculations.

A study was also made to determine whether or not there was going to be any problems with brass flying around inside the turret if a semi-automatic breech was used. This was done by putting an empty brass case in the cannon and manually opening the breech as fast as possible. At 0° Q.E. the brass barely came out of the breech far enough to fall clear. At higher Q.E. it came out faster,

however, it could be caught by hand, therefore, no built-in catcher was needed.

On the M551 Vehicle with the M81E12 Cannon mounted, the assembly around the trunnions is muzzle heavy by 4800 in-lb. The total assembly weighs 2719 lb., therefore the C.G. of the mechanism is \approx

$$\frac{4800 \text{ in-lb}}{2719 \text{ lb}} = 1.76 \text{ in} \leftarrow$$

In front of the trunnions. It is desired to find the C.G. of everything but the tube and breech around the trunnions.

$A_1 = \text{Tube \& breech} = 1120 \text{ lb}$	$\bar{x}_1 = 28.9 \text{ in}$
$A_2 = \text{Rest of Ass.} = 1600 \text{ lb}$	$\bar{x}_2 = ?$
$A_{\text{Tot}} = 2720 \text{ lb}$	$\bar{x}_{\text{Tot}} = 31.7$

All \bar{x} taken from the breech end of round.

$$\bar{x}_{\text{Tot}} = \frac{A_1 \bar{x}_1 + A_2 \bar{x}_2}{A_1 + A_2} \quad \text{or}$$

$$31.7 = \frac{1120(28.9) + 1600(\bar{x}_2)}{2720.}$$

$$\bar{x}_2 = 33.66 \text{ in. from the breech end of round}$$

or 3.8 in. in front of the trunnions

\bar{x}_2 is the X.G. for everything but the tube and breech around the trunnions.

The weight and C.G. of the adapter and collar used with the RIA 137155 assembly (See Drawing in Appendix) is 297.5 lb. at 19.0 in. from the rear of the adapter.

The weight of the adapter alone is 260.2 lb and the C.G. is 21.6 in. measured from the rear of the adapter.

It is desired to get the C.G. of the M103E7 Cannon and adapter assembly together.

A_1 = Gun tube & breech = 852 lb Actual Wt. (exp)

\bar{x}_1 = 38.8 in. from rear of breech Actual C.G. (exp)

A_2 = Adapter & collar = 297.5 lb. - exp

\bar{x}_2 = 30.6 in. in front of back side of breech

$$\begin{aligned}\bar{x}_{\text{Tot}} &= \frac{A_1 \bar{x}_1 + A_2 \bar{x}_2}{A_1 + A_2} \\ &= \frac{852.(38.8) + 298(30.6)}{852 + 298} = 36.68\end{aligned}$$

Therefore for the components to be added to the system

\bar{x}_c = 36.68 in. in front of the rear face of breech

A_c = 1150 lb.

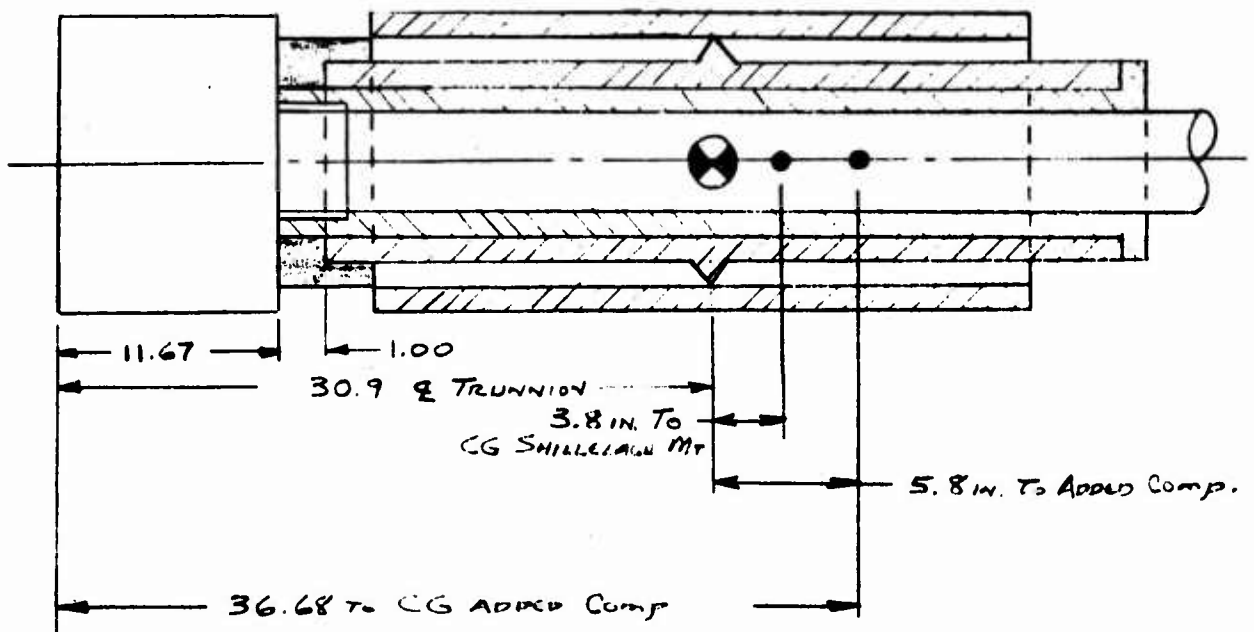

It is now desired to find the C.G. of the XM103E7 tube and breech with added components in the Shillelagh Mount.

$$A_c = \text{added pieces} = 1150 \text{ lb}$$

$$\bar{x}_c = 36.7 \text{ in.}$$

$$A_2 = 1600 \text{ lb.} = \text{Shillelagh Mount}$$

$$\bar{x}_2 = 34.7 \text{ in.}$$

$$\bar{x}_{\text{Tot}} = \frac{1150(36.7) + 1600(34.7)}{1150 + 1600} = 35.54 \text{ in.}$$

or 4.6 in. in front of the trunnions

This gives a muzzle heavy unbalance of

$$4.6 \text{ in.}(2750 \text{ lb}) \approx 12,650 \text{ in. lb.} \longleftarrow$$

Experimental data showed that theoretical unbalance of the M551 Mount to be ≈ 2870 in-lb too great therefore our first firing unbalance was approximately - $12650 - 2870 = 9780$ in. lb.

The 4800 in. lb. figure received over the phone from Allison was evidently in error. These discrepancies can be expected because of the speed with which this job was running.

The unbalance of the Shillelagh Mount with the XM103E7 Cannon and adapter assembly was determined experimentally to be approximately 101. in. in front of the trunnions. The unbalance was 98. lb. This gives a total unbalance torque of $T = 101 \text{ in.}(98 \text{ lb}) = 9900$ in-lb.

WEIGHTS & C.G.'S OF ADDED PARTS

- Collar & Adapter

$$A_1 = 298 \text{ lb.} \quad \bar{x}_1 = 19.0 \text{ in. from end adapter}$$

- XM103E7 Cannon

$$A_2 = 852 \text{ lb.} \quad \bar{x}_2 = 38.8 \text{ in. from rear breech}$$

- C.G. of Added Parts

$$\bar{x}_{\text{Tot}} = \frac{298(30.7) + 852(38.8)}{298 + 852} = \frac{42206.2}{1150} = 36.7 \text{ in.}$$

The unbalance torque these parts contribute to the system is:

$$(36.7 - \text{Dist Trunnion To End of Breech})(1150 \text{ lb})$$

$$(36.7 - 30.9)(1150) = 6670 \text{ in. lb.}$$

Therefore the unbalance of the mount alone must be

$$9900 - 6670 = 3230 \text{ in. lb.} \leftarrow$$

As compared to

$$(33.7 - 29.9) (1600) \approx 6100 \text{ in. lb.} \leftarrow$$

$$\text{Correction for Shillelagh Mount} = 6100 - 3230 = \underline{2870 \text{ in. lb.}}$$

Calculations for the XM180 System which was fired 1 - 3 April 1967

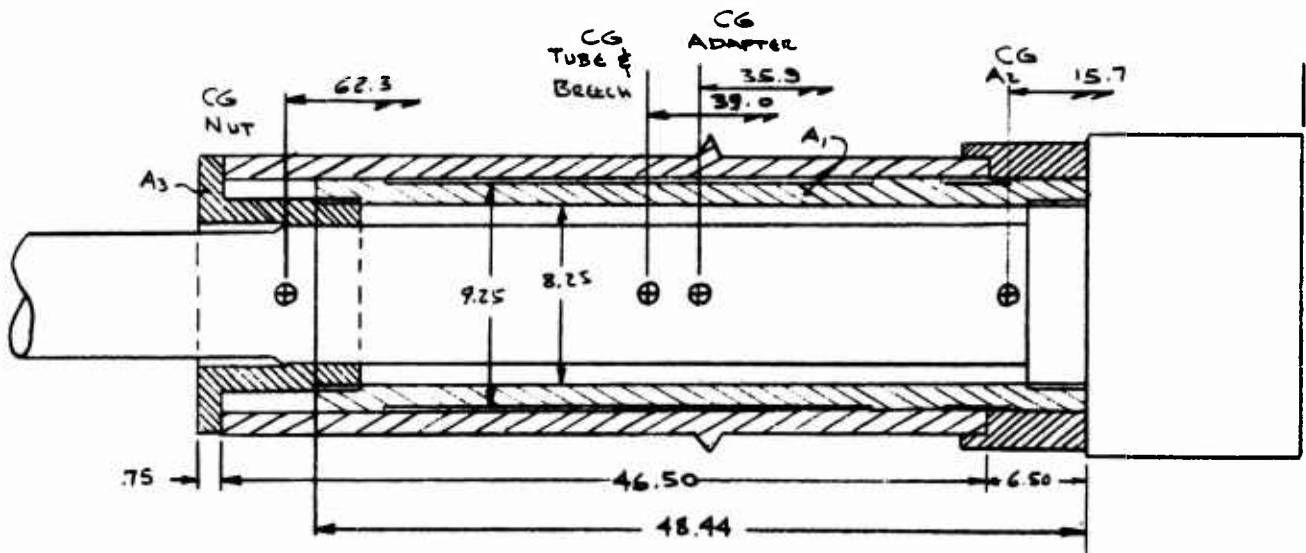

Adapter A_1

$$\text{O.D.} = 9.25 \rightarrow 67.201 \quad \text{Length} = 48.44 \text{ in.}$$

$$\text{I.D.} = 8.25 \rightarrow \frac{53.456}{13.745 \text{ in}^2}$$

$$A_1 = (.283)(13.75)(48.4) = 188.5 \text{ lb.} \quad \bar{x}_1 = 35.9$$

Collar A_2

$$\text{Total Weight} = A_2 = 124.7 \text{ lb.} \quad \bar{x} = 15.7$$

Nut A_3

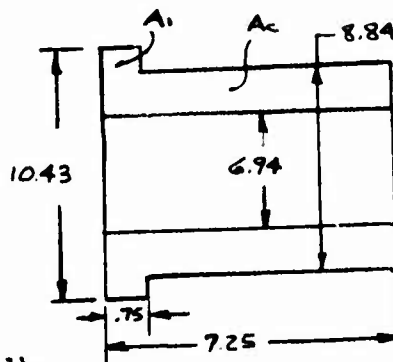

$$A_1 \text{ O.D.} = 10.43 \rightarrow 85.395$$

$$A_1 \text{ I.D.} = 8.44 \rightarrow \frac{55.917}{29.478}$$

$$A_1 = (29.478)(.75)(.283) = 6.26 \text{ lb.}$$

$$\bar{x}_1 = .375 \text{ from left end}$$

$$A_2 \text{ O.D.} = 8.44 \rightarrow 55.917$$

$$A_2 \text{ I.D.} = 6.94 \rightarrow \frac{37.807}{18.110}$$

$$A_2 = (18.110)(7.25)(.283) = 37.16$$

$$\bar{x}_2 = 3.625$$

$$\bar{x}_{\text{Tot}} = \frac{(6.26)(.375) + 37.16(3.625)}{37.16 + 6.26} = \frac{137.05}{43.42} = 3.16 \text{ from left side}$$

$$\bar{x}_2 = 62.3 \text{ in.} \quad A_2 = 43.4 \text{ lb.}$$

Gun Tube & Breech

Wt = 890 lb. C.G. 39.0 in. from end breech

Weight & Total C.G.

$$\bar{x}_{\text{Tot}} = \frac{(188.5)(35.9) + (124.7)(15.7) + 43.4(62.3) + 890(39.0)}{188.5 + 124.7 + 43.4 + 890}$$

$$= \frac{46138.76}{1246.6} = 37.0 \text{ in.} \quad \text{Total Wt.} = 1246.6$$

The trunnions are 36.4 in from the rear of the breech. Unbalance is therefore

$$(37.0 - 36.4)(1246.6) = 748. \text{ in. lb.} \approx 750 \text{ in. lb.}$$

The unbalance of the 551 Mount alone is

3230 in. lb. Muzzle Heavy

The total unbalance of the system is

3230 + 750 \approx 3980 in. lb.

Experimental unbalance was 3700 in. lb.

Weight of Recoiling Parts:

Gun Tube & Breech	890. lb.
Adapter	189.
Collar	125.
Nut	43.
1/2 Wt. Recoil Spring	28.
Inner Recoil Sleeve	183.
	<hr/>
Total Wt Recoiling Parts	1458. lb.

This was needed for the computer studies

The following parts were used to make up the first test rig of the M32 Cannon and M76 Mount in the M551 Vehicle.

System Component Weights

Recoil Mechanism & Oil	292. lbs.
Replenisher	21.
Machine Gun w/Mount & Brass Catcher	59.
Elevation Link	25.
Lead Weight	160.
Guards	129.
Lead Weight in Guards	144.
Cannon w/Muzzle Brake & Bore Evacuator	1337.
Ballistic Shield	548.
Adapter	253.
Instrumentation & Fasteners	25.
	<hr/>
Total	2993. lbs.

The following tests were conducted to determine any clearance problems for elevation, depression, and loading.

For elevation at 240.6 mils the bottom nut on the right gunners guard mount interferes with the elevation handwheel housing. This nut and mount can easily be moved back to clear. The mount was actually removed and a maximum elevation of 320 mils (18°) was achieved. Maximum Q.E. for the Shillelagh was 323 mils.

At minimum Q.E. the replenisher interfered with the top of the turret at -7 mils. If it was moved back a couple of inches or attached to the turret full depression could be attained.

The minimum clearance for loading at any Q.E. is 38.0 in., and the round is 34.0 in. so there is actually 4 in. of clearance.

The problems in unbalance were also found. The unbalance around the trunnions was taken experimentally, while the assembly was still in the turret and was found to be about 13,000 in. lb. This figure is including all the lead weight added for counter-balance. It was noted that by setting the cannon approximately 2.0 in. farther back in the turret, clearance problems for elevation and depression would be eliminated and at the same time the unbalance around the trunnions would be reduced.

The amount of unbalance gained is equal to the total weight minus the weight of the ballistic shield and the adapter times the two inches moved back or $(2993 - 253 - 548)(2) = 4384$ in. lb. gained. The unbalance left: $13,000 - 4384 = 8616$ in. lb. (Muzzle Heavy). The desired unbalance is 6000 in. lb.

It doesn't seem to be practicable to move the cannon any farther into the turret, since the M76 ammunition is 34.0 in. long, and the clearance between the back of the breech and the turret is 36.0 in. leaving only 2 in. clearance for loading.

Another possible armament for the M551 Vehicle was the M32 Cannon cut off to 125.9 in. and bored out to 105mm, and set in the M76 recoil mechanism.

1. Modified M32

Breech Weight	380.0 lb
Gun Tube	<u>637.0</u>
Total	1017.0 lb.

C.G. 37.4 in. forward the rear face of the breech ring, contributes *3050 in-lb of unbalance around the trunnions (breech heavy).

2. M32 Cannon

Breech Weight	338.0 lb.
Gun Tube	952.0
Bore Evacuator &	
Muzzle Brake	<u>47.0</u>
Total	1337.0 lb.

*C.G. 61.6 in forward of the rear face of breech ring, *contributes 28,344 in-lb. of unbalance around trunnions (muzzle heavy).

The unbalance of the complete M76 mount (including ballistic shield) without the M76 Cannon is:

$$28,340 - 13,000 = 15,340 \text{ in-lb. } \underline{\text{Breech Heavy}}$$

*Note: All based on the M76 Mount where the distance from the rear face breech ring to trunnions is 40.4 in.

Removing the lead weights added for balance to the previous M76 system 203 lb. @ 8500 in-lb leaves a lone mount with:

$$15,340 - 8500 = 6840 \text{ in-lb. (Breech Heavy)}$$

of unbalance.

By adding in the unbalance of the new cannon:

$$6840 + 3050 = 9890 \text{ in-lb. (Breech Heavy)}$$

the total unbalance of the new system is found.

For determining any clearance problems for this system, the notes for the M32 Cannon in the M76 Mount are to be used.

The 9890 in-lb. breech heavy condition does not include the bore evacuator from the 90mm Cannon which would bring the system into a balance within the prescribed limits.

Another possibility considered was cutting off the M32 Cannon until it balanced correctly about the trunnions in the M551 Vehicle. From the calculations in the back of this section, it was found that if approximately 30.0 in. of the gun tube was cut off, it would have an unbalance of 6660. in-lb muzzle heavy.

This figure is for the M76 Mount and all clearance problems will be the same as those for the M32 Cannon in the M76 Mount. This figure is very good since it does not include any attached lead weights. Cutting off the gun tube does effect such things as muzzle velocity, overpressure, stability of projectile, and possible excessive erosion at the muzzle end of the gun tube. The graph on the following page shows the relationship of the travel in bore to the muzzle velocity of the M352A1 Projectile for the M32 Cannon.

It is desired to cut the M32 gun tube off to make it balance in the trunnions of the M76 Mount in the M551 Vehicle. The balance is desired without any lead weights. The unbalance of this system now is 13,000 in. lb. muzzle heavy (+) with added lead weights on the breech side of the trunnions.

Wts to be removed or added	Distance from trunnion	Unbalance
75.5 lb. Left Ballast	35.0	+ 2642.5
65.5 lb. Right Ballast	48.0	+ 3144.0
160.0 lb. Bottom	20.0	+ 3200.0
26.5 lb. Muzzle Brake	146.3	- 3877.0
20.5 lb. Bore Evacuator	134.4	- 2755.2

MUZZLE VELOCITY VS. TRAVEL OF PROJECTILE IN BORE
76 MM - M352 AT ROUND
R. HOLZWORTH
27 MARCH 1967

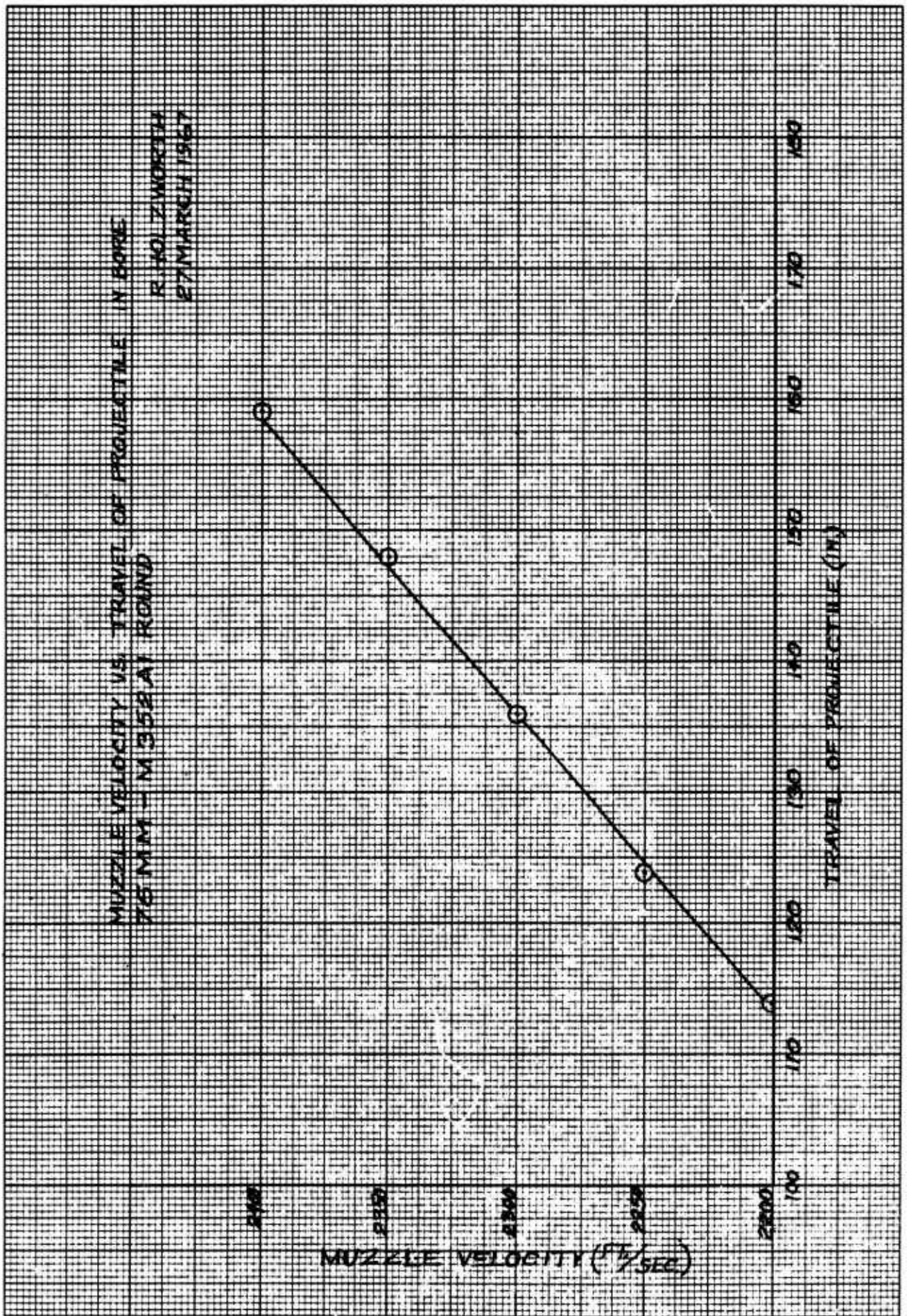

(Continued from page 41)

Total Negative - 6632.2
Total Positive - 8986.5
Net Gain - 2354.3

New Unbalance

$$13,000 + 2354.3 = 15,354.3$$

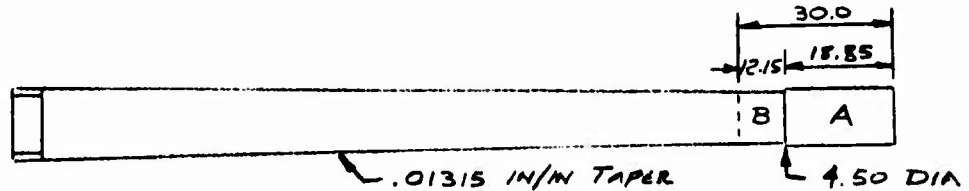

Section B

Bore = 3 in.

Conic Sect $V_T = .2618 h (D^2 + Dd + d^2)$

$$C = 4.50 \quad D = 4.50 + .01315(12.15) = 4.66$$

$$h = 12.15$$

$$V_T = .2618(12.15) [4.66^2 + (4.50)(4.66) + 4.50^2]$$
$$= 200.19$$

Cylin Sect $\pi/4 d^2 L = .7854(3)^2 (12.15) = 85.88$

$$\text{Total Wt} = (200.19 - 85.88)(.283) = 32.35 \text{ lb}$$

$$\bar{x} \text{ from trunnion} = 122.40$$

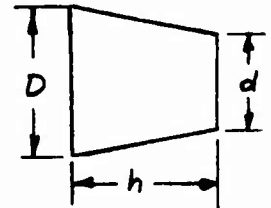

Section A

Assume	O.D. - 4.65	Wt = .7854(4.65 ² - 3.0 ²)(17.85)(.283)
	I.D. - 3.00	= 50.08 lb.
	L - 17.85	

$$\bar{x} \text{ from trunnion} = 137.32$$

Cutting off this much of the gun tube and adding the bore evacuator again

Weight (on or off)	C.G. to Trunnion	Unbalance
32.4 lb.	- 122.4 in.	- 3965.8
50.1 lb.	- 137.3 in.	- 6878.7
20.5 lb.	+ 105.0 in.	+ 2152.5

Net Gain = -8692.0

New Unbalance = 15354.3 - 8692.0 = 6662.3 in-lb.

The component parts used for the M32 Cannon in the M551 Mount are:

1. M32 Cannon

Breech partly modified to clear torque key on the M551 gunners guard. All manual breech, wt = 1305 lb., C.G. 61.7 in. forward rear face of breech ring.

2. Mount - from M551 Vehicle

3. Adapter Assembly - M32 Cannon to M551 Mount.

The total unbalance of all these components assembled into the M551 Vehicle was taken experimentally around the trunnions and found to be 42,560 in-lb. No attempt to balance this was made, since it could be fired this way by locking out the elevating mechanism and not enough lead could reasonably be added and yet balance it correctly.

While in the turret the mechanism was checked for clearance during elevation and depression. At +222 mils the bottom of the breech interfered with the handwheel elevation housing. By moving the cannon back in the mount approximately 4 in., the breech could be made to clear. This would also help to balance the mechanism around the trunnions by approximately: 4 in. (1305 lb) = 5220 in-lb. Maximum depression was achieved with the mechanism as it was. The clearance between the rear of the breech and the turret was 46.0 in.

It is desired to cut the M76 gun tube off approximately 40.0 in to help the unbalance.

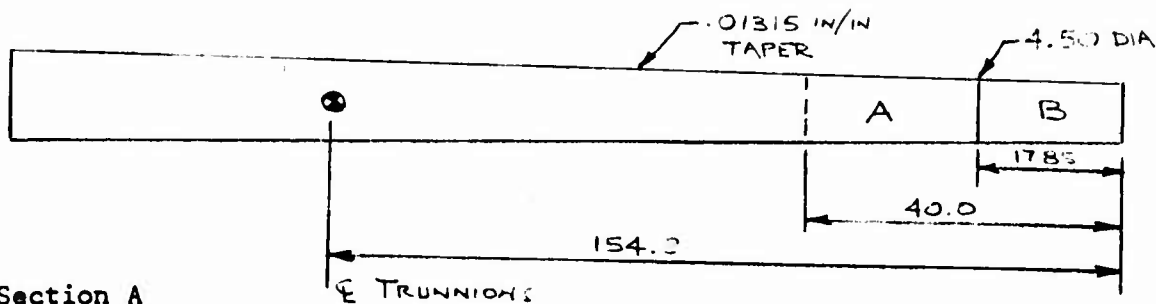

Section A

$$\begin{aligned}
 n &= 22.15 & D &= 4.79 & d &= 4.50 \\
 W_A &= .2618h(D^2 + dD + d^2) .283 - \pi/4(3)^2 .283 \\
 &= 106.26 - 44.31 \\
 &= 61.95 \text{ lb.}
 \end{aligned}$$

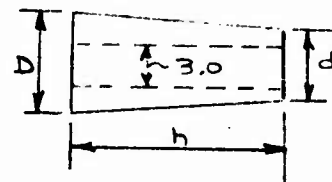

Section B

Assume O.D. = 4.65 in.
I.D. = 3.0 in.

$$\begin{aligned}
 W_B &= .7854(4.65^2 - 3.00^2)(17.85)(.283) \\
 &= 50.08 \text{ lb.}
 \end{aligned}$$

New Unbalance:

Muzzle Brake	26.5 lb	@	154.2 in	4086.3
Bore Evacuator	20.5 lb	@	143.0 in	2931.5
Part B	50.1 lb	@	145.2 in.	7274.5
Part A	62.0 lb	@	125.2 in.	<u>8764.0</u>

Unbalance Gained: 23,056.3 in-lb.

$$\text{Unbalance} = 37340 - 23060 = 14,280 \text{ in-lb.}$$

This mechanism this way should be able to achieve maximum elevation and depression. There is approximately 42.0 in. between the rear face of the breech and the turret. Since the 76mm round is 34.0 in. there is enough room to load and possibly enough to move the cannon back another 4.0 in. to help the unbalance.

APPENDIX C
TEST PROGRAM REQUESTS &
TEST & EVALUATION RANGE REPORTS

1. Test Program Requests

The following test program requests are included for reference purposes:

<u>Number</u>	<u>Title</u>
RIA-9310-CV-200-1	M103 Cannon & Recoil Mechanism For The M81E12 Cannon
RIA-9310-CV-200-2	M32 Cannon In M76 Recoil Mechanism
RIA-9310-CV-200-3	XM180 Cannon With Adapter Assembly (67F885) & Recoil Mechanism For The M81E12 Cannon
RIA-9310-CV-200-4	M32 Cannon & Recoil Mechanism For The M81E12 Cannon

TEST PROGRAM REQUEST

DATE:

9 March 1967

1. MATERIAL FOR TEST:

See below

2. TEST PROGRAM REQUEST NO.
RIA-9310-CV-200-13. EX ORDER NO:
547104. TESTING INSTALLATION:
T&E Range, Rock Island Arsenal**1. Material for Test:**

M103 Cannon adapted to an XM551 vehicle. The adaptation uses the recoil mechanism for the M81E12 Cannon.

3. Project Authority:**6. Object of Development:**

To obtain instrumented data to be used to evaluate the characteristics of the recoil mechanism in its new environment, and to measure counterrecoil forces that may be used to actuate a semi-automatic breech.

7. History:

This is a new development.

8. Description of Equipment:

- a. M551 Vehicle with Mount for M81E12 Cannon.
- b. M103 Cannon Auxiliary Gun Mount (RIA 137155).
- c. Hand operating breech handle and lock.
- d. XM103E7 Cannon for the XM104 Vehicle. (This cannon was originally designed for the XM104 vehicle).
- e. Photographic equipment.
- f. Instrumentation equipment.
- g. Zone 7 105mm ammunition with the M1 Projectile (Zones 3, 4, 5, and 6 for warm-up only).

9. Recommended Test Program:

- a. Inspection. Upon receipt of the vehicle at the proving ground, the location of the adapter nut and its locking ring should be noted. The locking ring should be checked after each round. A visual inspection should be made of the gun and recoil system between each round.
- b. Instrumentation should be taken on all rounds including the warm-up rounds. After verification of some parameters, some of the instrumentation can be discontinued on later rounds at the discretion of the project engineer in charge from 9310-CV.

TEST PROGRAM REQUEST		DATE:
1. MATERIAL FOR TEST:		2. TEST PROGRAM REQUEST NO. RIA-9310-CV-200-1
3. EX ORDER NO:	4. TESTING INSTALLATION:	
<p>c. The recoil mechanism will be pumped up to its 850 psi by gage instead of using the safe-to-fire indicator only. The pressure gage will be connected with a quick disconnect and removed before firing.</p> <p>d. The breech operating handle must be removed before each firing and before the round is entered into the chamber. The breech block must be locked in position before firing. This is a manual lock positioned with a thumb screw on the right side of the breech operating mechanism. (This is a test rig only and normal proving ground safe testing procedures apply).</p> <p>e. The lanyard to fire the gun should be pulled to the outside of the tank and fired from a protected position. No personnel should be in an exposed position.</p> <p>10. <u>Instrumentation:</u></p> <p>a. Full camera coverage. Fastex and standard movies should be taken inside the turret focused on the recoil mechanism and breech from the left rear. A fastex sequence should be taken of an empty cartridge ejection and where it bounces in the turret. Sixteen millimeter colored movies should be taken of the whole vehicle during firing. Still shots of the whole instrumentation complex and other items may be required during the test. Adequate film should be available for this type activity.</p> <p>b. The following instrumentation other than photographic will be required:</p> <p>(1) Time displacement of the recoil mechanism through fifteen (15) inches of travel.</p> <p>(2) Time displacement through three (3) inches of buffer travel.</p> <p>(3) Time displacement through one (1) inch travel of the belleville spring pack.</p> <p>(4) Acceleration in recoil and counterrecoil of the recoiling parts. Traces should be reducible to recoil velocities.</p> <p>(5) Oil pressure versus time from two (2) locations. One gage should be connected in front of the recoil piston and one at the rear of the mechanism. Expected pressures are from the 850 psi pressure to a maximum of 2700 psi.</p> <p>(6) Copper gage maximum chamber pressure.</p> <p>(7) Muzzle velocity.</p>		

TEST PROGRAM REQUEST

DATE:

1. MATERIAL FOR TEST:

2. TEST PROGRAM REQUEST NO.
RIA-9310-CV-200-1

3. EX ORDER NO:

4. TESTING INSTALLATION:

(8) The above instrumentation may be altered or deleted as results from the first firings progress. This will be at the discretion of the project engineer from 9310-CV.

11. Firing Sequence:

- a. Four instrumented warm-up rounds will be fired using zones 3, 4, 5, and 6.
- b. At least three (3) rounds of zone seven (7) ammunition will be fired with full instrumentation. If some data is lost during this sequence, additional rounds will be fired so that recorded data will be reproducible for three rounds.

12. Precautions in Handling and Testing:

- a. The usual care in handling and testing will be required.
- b. Particular attention should be paid to laying the lanyard. It should not be connected to the gun until the area has been cleared.
- c. The locking ring on the adapter should be checked between each round. A trap door in the dust cover can be opened for this check.
- d. Other safety requirements may be required by the firing director or the safety officer.

13. Remarks:

14. References:

- a. DF from SWERI-RDD-CV-9310 dated 2 March 1967.
- b. RIA Sketch Number 137155 and associated drawings.
- c. TM's and drawings on the M551 vehicle and the M103 gun.

TEST PROGRAM REQUEST

DATE:

16 March 1967

1. MATERIAL FOR TEST:

See below

2. TEST PROGRAM REQUEST NO.

RIA-9310-CV-200-2

3. EX ORDER NO:

54710

4. TESTING INSTALLATION:

T&E Range, Rock Island Arsenal

1. Material for Test:

76mm, M32 Cannon in M76 Recoil Mechanism adapted to the M551 Vehicle by Adapter 67F655.

3. Project Authority:6. Object of Development:

To obtain instrumented data to be used to evaluate the characteristics of the M32 Cannon in the M76 Recoil Mechanism in its new environment, and to measure the ejection velocity of the empty case as it is ejected semi-automatically by the breech operating cam.

7. History:

This is a new development.

8. Description of Equipment:

a. M551 Vehicle with an M32 Cannon mounted in the M76 Recoil Mechanism. The recoil mechanism is adapted to the M551 ballistic shield by Adapter 65F655.

b. Shell case catcher in the turret.

c. Photographic equipment.

d. Instrumentation equipment.

e. Ammunition:

(1) 76mm, M352A1

(2) 76mm, TPM 340

(3) 7.62mm machine gun ammunition

f. M73 Machine Gun

9. Recommended Test Program:

a. Inspection: Before the gun is fired, clearances must be checked in all positions. If necessary, gymnasticating the recoil mechanism in the vehicle may be required.

TEST PROGRAM REQUEST		DATE:
1. MATERIAL FOR TEST:		2. TEST PROGRAM REQUEST NO. RIA-9310-CV-200-2
3. EX ORDER NO:	4. TESTING INSTALLATION:	
<p>b. All radio and other equipment that can be damaged by flying brass in the turret <u>must</u> be protected by padding of some sort.</p> <p>c. An empty case catcher is required. This can be a wire framework covered by canvas with a canvas bag on the bottom. Shell ejection velocity should be measured. This could be accomplished by a grid board and fastex camera looking into the turret through a hatch. Records should be made of three (3) rounds each of the M352A1 and TPM 340 rounds.</p> <p>d. Instrumentation should be taken on all rounds. After verification of some parameters, some of the instrumentation can be discontinued on later rounds at the discretion of the project engineer from 9310-CV.</p> <p>e. The lanyard to fire the gun, or the wire if fired electrically, should be activated from a remote protected position. No personnel should be in an exposed position.</p> <p>10. <u>Instrumentation:</u></p> <p>a. Full camera coverage. Fastex through hatch in turret to check velocity of the ejected shell case. Colored movies of the overall vehicle during firing. Fastex for two (2) rounds each of the M352A1 and TPM 340 rounds aimed at the dust cover on the ballistic shield. Color slides and 8 x 10 stills as required for recording the set-ups and any changes that may occur during testing.</p> <p>b. The following instrumentation other than photographic will be required:</p> <p>(1) Recoil velocity versus time.</p> <p>(2) Muzzle velocity.</p> <p>(3) Time displacement of recoil and counterrecoil through a maximum of twelve (12) inches.</p> <p>(4) Acceleration of recoiling parts.</p> <p>(5) Recoil oil pressure versus time from rear of recoil mechanism.</p> <p>(6) Vehicle hop.</p> <p>(7) The above instrumentation may be altered or deleted as results of the first firings progress. This action will be at the discretion of the project engineer from 9310-CV.</p>		

TEST PROGRAM REQUEST		DATE:
1. MATERIAL FOR TEST:		2. TEST PROGRAM REQUEST NO. RIA-9310-CV-200-2
3. EX ORDER NO:	4. TESTING INSTALLATION:	
<p>11. <u>Firing Sequence:</u></p> <ul style="list-style-type: none"> a. Fire six (6) rounds of M352A1 ammunition. The first three will be considered warm-up rounds, but instrumentation is still required. Picatinny Arsenal has been asked to put breech force pressure copper gages into several of the rounds and mark them. The rounds with gages inside should be used for the warm-up rounds. Full charges only will be fired because this is fixed ammunition. b. Additional rounds may be required if some of the test data is not satisfactory. c. Fire six (6) rounds of TPM 340 ammunition. The instrumentation should be made on the quick development paper and the last three on the permanent type. d. After the warm-up rounds have been fired in paragraph 11a above, permanent type recording paper should be used. e. Additional rounds may be fired as needed at the discretion of the project engineer from 9310-CV. f. After firings of the main armament are completed, the M73, 7.62mm machine gun should be fired to check the coaxial mount. The rounds will be fed from the standard M551 ready round storage. The M551 brass catcher will be used with the new mount. If one-hundred (100) rounds feeds through and fires satisfactorily, the test can be terminated. If they will not feed through and fire adequately, a determination will be made by the project engineer from 9310-CV for a continuation of the test. <p>12. <u>Precaution in Handling and Testing:</u></p> <ul style="list-style-type: none"> a. The usual care in handling and testing will be required. b. Particular attention should be paid to laying the firing cable or lanyard to a protected area outside the vehicle. c. The safety director will determine whether the M73 machine gun should be fired from inside or outside the vehicle. d. Other safety measures may be required by the firing director or the safety director. e. The TPM 340 round is a tracer round. There is a possibility of fire in the sand pit. Adequate fire fighting apparatus should be available. 		

TEST PROGRAM REQUEST

DATE:

1. MATERIAL FOR TEST:

2. TEST PROGRAM REQUEST NO.
RIA-9310-CV-200-2

3. EX ORDER NO:

4. TESTING INSTALLATION:

13. Remarks:

- a. If radio equipment cannot be adequately protected inside the vehicle from flying empty cases, the delicate equipment should be removed from the turret before the test.
- b. The empty case catcher is still required even if the radio equipment is removed.

14. References:

- a. Assembly Drawing 67F738
- b. TM on M73 Machine Gun
- c. TM on M76 Recoil Mechanism
- d. TM on M551 Vehicle

TEST PROGRAM REQUEST		DATE: 20 March 1967
1. MATERIAL FOR TEST: See below		2. TEST PROGRAM REQUEST NO. RIA-9310-CV-200-3
3. EX ORDER NO: 54710	4. TESTING INSTALLATION: T&E Range, Rock Island Arsenal	
<p>1. <u>Material for Test:</u></p> <p>105mm Cannon XM180 mounted with Adapter Assembly 67F885 in the M81E12 recoil mechanism in the M551 vehicle.</p> <p>3. <u>Project Authority:</u></p> <p>6. <u>Object of Development:</u></p> <p>To obtain instrumented data to be used to evaluate the characteristics of the XM180 Cannon in its intended environment, check empty case ejection velocity, develop a breech actuating cam, and to see if the M73 Machine Gun operates satisfactorily in this application.</p> <p>7. <u>History:</u></p> <p>This is a new development.</p> <p>8. <u>Description of Equipment:</u></p> <p>a. An M551 Vehicle with an XM180, 105mm Cannon mounted into the recoil mechanism for the M81E12 Gun by Adapter Assembly 67F885.</p> <p>b. Empty case catcher in the turret.</p> <p>c. Photographic equipment.</p> <p>d. Instrumentation equipment.</p> <p>f. Ammunition:</p> <p>(1) Zones 3, 4, 5, and 6 warm-up rounds.</p> <p>(2) Zone 7 M1 rounds.</p> <p>(3) Equivalent zone 7 rounds using disintegrating projectiles for high angle fire.</p> <p>(4) 7.62mm machine gun ammunition.</p> <p>9. <u>Recommended Test Program:</u></p> <p>a. <u>Inspection:</u> Before either gun is fired, clearances must be checked around the guns at all quadrant elevations. Fifteen (15) inches must also be allowed for the recoiling mass during this check. If necessary, setting the gun out-of-battery the maximum distance may be required at zero prepressure to check clearances at full recoil.</p>		

TEST PROGRAM REQUEST

DATE:

1. MATERIAL FOR TEST:

2. TEST PROGRAM REQUEST NO.
RIA-9310-CV-200-3

3. EX ORDER NO:

4. TESTING INSTALLATION:

- b. All radio and other equipment that can be damaged by flying brass in the turret must be protected by padding of some sort. Otherwise delicate equipment must be removed from the turret.
- c. An empty case catcher is required. This can be the same one that was used with the test in TPR RIA-9310-CV-200-2.
- d. Instrumentation should be taken on all rounds. After verification of some parameters by test, some of the instrumentation can be discontinued on later rounds at the discretion of the project engineer from 9310-CV.
- e. The lanyard to fire the gun should be activated from a remote protected position. No personnel should be in an exposed position.

10. Instrumentation:

- a. Full camera coverage. Fastex through hatch in turret to check velocity of the ejected shell case on semi-automatic operated breech firings only. Fastex through the hatch of M73 machine gun while it is being fired. Colored movies of the overall vehicle during firing. Fastex of three (3) rounds of the ejection of the empty case to check shell velocity. This can be taken through the hatch with a grid board under the shell opposite of the camera. The distance from the grid board to the centerline of the shell and to the lens of the camera is required for accurate measurement of the shell velocity. Color slides and 8 x 10 stills are required for set-ups and any changes that may occur during testing.
- b. The following instrumentation other than photographic will be required:
 - (1) Recoil velocity versus time.
 - (2) Muzzle velocity.
 - (3) Time displacement of recoil and counterrecoil through a maximum of fifteen (15) inches.
 - (4) Acceleration of recoiling parts.
 - (5) Recoil oil pressure versus time in two places.
 - (6) Vehicle hop.
 - (7) Time displacement of buffer travel.

TEST PROGRAM REQUEST

DATE:

1. MATERIAL FOR TEST:

2. TEST PROGRAM REQUEST NO.
RIA-9310-CV-200-3

3. EX ORDER NO:

4. TESTING INSTALLATION:

(8) Time displacement of the belleville spring pack.

(9) Copper gage maximum chamber pressure.

(10) The above instrumentation may be altered or deleted as results from the first firings progress. This will be at the discretion of the project engineer from 9310-CV.

11. Firing Sequence:

- a. Fire 1,000 rounds of 7.62mm ammunition through the M73 machine gun. If the gun malfunctions other than a simple jam, cease fire but record all causes of malfunctions if known. (There seems to be a history of vibrations of the gun in this mount that can cause malfunctions.)
- b. Four (4) instrumented warm-up rounds will be fired using zones 3, 4, 5, and 6.
- c. At least three (3) rounds of zone seven (7) ammunition will be fired with full instrumentation. If some data is lost during this sequence, additional rounds will be fired so that recorded data will statistically be valid for three rounds.
- d. The rounds in paragraph 11b and c above will be fired with no breech operating cam attached. After the cam is attached the same firing sequence will be repeated.
- e. If the breech cam operates the breech adequately at zero Q.E., the gun should be fired at maximum elevation using disintegrating projectiles. Three (3) reproducible rounds should be fired using fastex film aimed at the breech operating cam area. Oil pressure in two places and time displacement should be recorded during the high elevation rounds.
- f. Additional firings may be required based on the data acquired from the above firings.

12. Precautions in Handling and Testing:

- a. The usual care in handling and testing will be required.
- b. Particular attention should be paid to laying the lanyard. It should not be connected to the gun until the area has been cleared.
- c. Other safety requirements may be required by the firing director or the safety officer.

TEST PROGRAM REQUEST

DATE:

1. MATERIAL FOR TEST:

2. TEST PROGRAM REQUEST NO.
RIA-9310-CV-200-3

3. EX ORDER NO:

4. TESTING INSTALLATION:

13. Remarks:

After verifying instrumented data by the rapid developing paper, permanent type paper should be used for the three reproducible rounds.

14. References:

- a. DF from SWERI-RDD-CV-9310 dated 2 March 1967.
- b. Drawing 67F885
- c. TM's and drawings on the M551 vehicle and the M103 series gun including the TM on the M108 vehicle.

TEST PROGRAM REQUEST		DATE: 21 March 1967
1. MATERIAL FOR TEST: See below		2. TEST PROGRAM REQUEST NO. RIA-9310-CV-200-4
3. EX ORDER NO: 54710	4. TESTING INSTALLATION: T&E Range, Rock Island Arsenal	
<p>1. <u>Material for Test:</u></p> <p>76mm, M32 Cannon mounted in the recoil mechanism for the M81E12 gun by Adapter 67K658. This mechanism is adapted to the M551 Vehicle.</p> <p>3. <u>Project Authority:</u></p> <p>6. <u>Object of Development:</u></p> <p>To obtain instrumented data to be used to evaluate the characteristics of the recoil mechanism in its new environment.</p> <p>7. <u>History:</u></p> <p>This is a new development.</p> <p>8. <u>Description of Equipment:</u></p> <p>a. M551 Vehicle with Mount for the M81E12 Cannon.</p> <p>b. M32 Cannon modified by cutting clearance on the upper right hand of the breech block.</p> <p>c. Hand operated breech handle and lock.</p> <p>d. Adapter assembly RIA 137152.</p> <p>e. Photographic equipment.</p> <p>f. Instrumentation equipment.</p> <p>g. 76mm, M352A1 ammunition.</p> <p>h. 76mm, TPM 340 ammunition.</p> <p>9. <u>Recommended Test Program:</u></p> <p>a. <u>Inspection:</u> Upon receipt of the vehicle at the proving ground, the adapter nut lock should be checked. This lock should be checked after each of the first three rounds as they are fired. If no change in position is noted after the first three rounds, no further checks will be required.</p> <p>b. Instrumentation should be taken on all rounds.</p>		

TEST PROGRAM REQUEST

DATE:

1. MATERIAL FOR TEST:

2. TEST PROGRAM REQUEST NO.
RIA-9310-CV-200-4

3. EX ORDER NO:

4. TESTING INSTALLATION:

- c. The recoil mechanism will be pumped up to its 850 psi pressure by gage instead of using the safe-to-fire indicator only. The pressure gage will be connected with a quick disconnect and removed before firing.
- d. The breech operating handle must be removed before each firing and before a round is entered into the chamber.
- e. The lanyard to fire the gun should be pulled to the outside of the tank and fired from a protected position. No personnel should be in an exposed position.

10. Instrumentation:

- a. Full camera coverage. Fastex coverage is required on the first three rounds only. The camera should be focused on the breech area through a turret hatch. Sixteen millimeter colored movies should be taken of the whole vehicle during firing. Still shots of the whole instrumentation complex and other items may be required during the test.
- b. The following instrumentation other than photographic will be required:
 - (1) Time displacement of the recoil mechanism through 15 inches of travel.
 - (2) Time displacement through one (1) inch travel of the belleville spring pack.
 - (3) Acceleration in recoil and counterrecoil of the recoiling parts.
 - (4) Recoil velocity versus time.
 - (5) Recoil oil pressure versus time from two (2) locations.
 - (6) Copper gage maximum chamber pressure on the first two rounds only.
 - (7) Muzzle velocity.
 - (8) Vehicle hop.
 - (9) The above instrumentation may be altered or deleted as results from the first firing progress at the discretion of the project engineer from 9310-CV.

<h1>TEST PROGRAM REQUEST</h1>	DATE:
-------------------------------	-------

1. MATERIAL FOR TEST:	2. TEST PROGRAM REQUEST NO. RIA-9310-CV-200-4
-----------------------	--

3. EX ORDER NO:	4. TESTING INSTALLATION:
-----------------	--------------------------

11. Firing Sequence:

- a. Fire one (1) round of 76mm, M352A1 ammunition with chamber pressure gage inside.
- b. Fire two (2) rounds without gage.
- c. The fourth round should have pressure gages inside.
- d. The above rounds will be fired using quick developing paper in the recording machine.
- e. The next three (3) rounds will be fired using a permanent type recording paper.
- f. Refirings of "e" above will be made only if the instrumented data is lost on some rounds. This will be at the discretion of the project engineer from 9310-CV.
- g. Fire three (3) 76mm TPM 340 rounds as warm-up with instrumentation. If these rounds are fired immediately after the rounds in "e" above, only one warm-up round will be required using quick readout paper.
- h. Fire three reproducible rounds of TPM 340 ammunition.
- i. The above is the total requirement unless instrumented data is lost on some rounds. A decision to fire additional rounds will be at the discretion of the project engineer from 9310-CV.

12. Precautions in Handling and Testing:

- a. The usual care in handling and testing will be required.
- b. Particular attention should be paid to laying the firing lanyard. It should not be connected to the gun until the area has been cleared.
- c. Other safety requirements may be required by the firing director or the safety officer.

13. Remarks:

The TPM 340 round is a tracer round. There is a possibility of fire in the sand pit. Adequate fire fighting apparatus should be available.

14. Reference:

- a. Assembly drawing RIA 137152.
- b. TM on M551 Vehicle.

2. Range Reports

The following test and evaluation range reports are included for reference purposes:

<u>Number</u>	<u>Date</u>
67-115	11 Mar 67
67-144	22 Mar 67
67-145	22 Mar 67
67-151	24 Mar 67
67-178	3 Apr 67
67-194	8 Apr 67

ROCK ISLAND ARSENAL
TEST AND EVALUATION RANGE REPORT NR. 67-115

DATE PREPARED: 11 March 1967	EX. ORDER NR: 54710-9003	TEST AUTHORIZED BY/COST CENTER/DATE: Memorandum/9310 CV/9 March 1967	PAGE 1	OF 1
--	------------------------------------	--	------------------	----------------

MATERIEL TESTED:
M103 Cannon adapted to an XM551 vehicle. The adaption uses the recoil mechanism for the M81E12 Cannon.

PURPOSE OF TEST:
To obtain instrumented data to be used to evaluate the characteristics of the recoil mechanism in its new environment, and to measure counterrecoil forces that may be used to actuate a semi-automatic breech.

FIXTURE AND/OR MATERIEL USED IN TEST:
M551 Vehicle with Mount for M81E12 Cannon
M103 Cannon Auxiliary Gun Mount (RIA 137155)

AMMUNITION COMPONENTS:
Primer, Percussion M28E2 (300 Grain)
Case, Cartridge, 105mm Howitzer M-14
Charge, Propelling M-67 Dualgran Ammunition Log S.P.IA - 61271
MP Lot IA-BR-61371
Projectile, Inert M-1 (33 lbs)

TEST PROCEDURE:
Test Program Request No. RIA-9310-CV-200-1 dated 9 March 1967

TEST DATA: Date of Test: 11 March 1967
Recuperator Pressure Direct 850 psi @48° Pin in from face 3/32

Round No.	Time	Charge-Prop (Zone-Type)	Recoil Length (Inches)	Chamber Pressure (psi)
1	10:20	3 - M67	9 1/4	Not Taken
2	10:38	4 - M67	11 1/8	Not Taken
3	10:55	5 - M67	13 1/4	17,400
4	12:28	6 - M67	14	22,900
5	1:11	7 - M67	14 5/8	36,500
6	1:13	7 - M67	14 5/8	37,400
7	1:26	7 - M67	14 5/8	38,400
8	1:40	7 - M67	14 5/8	38,400

This concluded the firing of this test per Mr. Rossmiller of 9310 CV.

Test was conducted by: D. J. Somers
Proof Director: D. H. Harksen

ROCK ISLAND ARSENAL
TEST AND EVALUATION RANGE REPORT NR. 67-144

DATE PREPARED: 22 March 1967	EX. ORDER NR: 54710-9003	TEST AUTHORIZED BY/COST CENTER/DATE: Memorandum/9310 CV/16 March 1967	PAGE 1	OF 2
---------------------------------	-----------------------------	--	-----------	---------

MATERIEL TESTED:
76 mm, M32 Cannon in M76 Recoil Mechanism adapted to the M551 Vehicle
Adapter 67F655

PURPOSE OF TEST:
To obtain instrumented data to be used to evaluate the characteristics of the M32 Cannon in the M76 Recoil Mechanism in its new environment, and to measure the ejection velocity of the empty case as it is ejected semi-automatically by the breech operating cam.

FIXTURE AND/OR MATERIEL USED IN TEST:
76 mm, M32 Cannon in M76 Recoil Mechanism adapted to the M551 Vehicle by
Adapter 67F655

AMMUNITION COMPONENTS:
Fixed ammunition 76 mm. M352 Lot PA-E-55922
Fixed ammunition 76 mm. M340A1 Lot I. O. P. 2-6-X

TEST PROCEDURE:
Test Program Request No. RIA-9310-CV-200-2 dated 16 March 1967

TEST DATA: Date of Test: 20 March 1967

Round No	Time	Recoil Length (Inches)	Type Ammunition	Chamber Pressure (psi)
1	3:32	8 1/4	M352	32,600
Date of Test: 21 March 1967				
2	9:57	8 9/16	M352	Not Taken
3	10:22	8 9/16	M352	Not Taken
4	10:29	8 5/16	M352	Lost
5	10:40	8 9/16	M352	Not Taken
6	10:52	8 9/16	M352	Not Taken
7	11:00	8 5/8	M352	Not Taken
8	11:10	8 5/8	M340A1	Not Taken
9	12:38	8 5/8	M340A1	Not Taken
10	12:45	8 5/8	M340A1	Not Taken

(Continued)

TEST AND EVALUATION RANGE REPORT NO. 67-144

Page 2 of 2

<u>Round No.</u>	<u>Time</u>	<u>Recoil Length (Inches)</u>	<u>Type of Ammunition</u>	<u>Chamber Pressure (psi)</u>
11	12:57	8 11/16	M340A1	Not Taken
12	1:04	8 5/8	M340A1	Not Taken
13	1:12	8 9/16	M340A1	Not Taken

Test conducted by: D. J. Somers
Proof Director: D. H. Harksen

ROCK ISLAND ARSENAL
TEST AND EVALUATION RANGE REPORT NR. 67-145

DATE PREPARED:	EX. ORDER NR:	TEST AUTHORIZED BY/COST CENTER/DATE:	PAGE	OF
22 March 1967	54710-9003	Memorandum/9310 CV/16 March 1967	1	1
MATERIEL TESTED: 7.62 mm. Machine Gun M-73 fired from M551 Vehicle				
PURPOSE OF TEST: Function fire weapon				
FIXTURE AND/OR MATERIEL USED IN TEST: 7.62 mm. Machine Gun M-73 Serial #2041 Mfr. Springfield Armory Fired from M551 Vehicle				
AMMUNITION COMPONENTS: Nato 7.62mm., Ball M-80 Lot L.C.L. 12367 linked				
TEST PROCEDURE: Test Program Request No. RIA-9310-CV-200-2 dated 16 March 1967.				
TEST DATA: Date of Test: 21 March 1967 One hundred rounds were fired at 4:33 Date of Test: 22 March 1967 Nine hundred rounds were fired between 8:05 and 8:45. The above firings were fired with controlled stoppages. Test was conducted by: C. Calhoun Proof Director: D. H. Harksen (DJS)				

ROCK ISLAND ARSENAL
TEST AND EVALUATION RANGE REPORT NR. 67-151

DATE PREPARED: 24 March 1967	EX. ORDER NR: 54710-9003	TEST AUTHORIZED BY/COST CENTER/DATE: Memorandum/9310 CV/21 March 1967	PAGE 1	OF 1
MATERIEL TESTED: 76 mm., M32 Cannon mounted in the recoil mechanism for the M81E12 gun by Adapter 67K658. This mechanism is adapted to the M551 Vehicle.				
PURPOSE OF TEST: To obtain instrumented data to be used to evaluate the characteristics of the recoil mechanism in its new environment.				
FIXTURE AND/OR MATERIEL USED IN TEST: 76 mm., M32 Cannon in M76 Recoil Mechanism adapted to the M551 Vehicle by Adapter 67K658.				
AMMUNITION COMPONENTS: Fixed ammunition 76 mm. M352 Lot PA-E-55922 Fixed ammunition 76 mm. M340A1 Lot I.O.P. 2-6-X				
TEST PROCEDURE: Test Program Request No. RIA-9310-CV-200-4, dated 21 March 1967				
TEST DATA: Date of Test: 24 March 1967				
Round No.	Time	Recoil Length (Inches)	Type Ammunition	Chamber Pressure (psi)
1	11:08	13 1/2	M352	Lost
2	1:14	13 7/8	M352	Not Taken
3	1:25	14 1/4	M352	Not Taken
4	1:32	14 1/4	M352	31,300
5	1:41	14 1/2	M352	Not Taken
6	1:47	14 1/2	M352	Not Taken
7	1:55	14 5/8	M340A1	Not Taken
8	1:58	14 11/16	M340A1	Not Taken
9	2:05	14 3/4	M340A1	Not Taken
10	2:12	14 7/8	M340A1	Not Taken
11	2:23	14 7/8	M340A1	Not Taken
12	2:30	14 7/8	M340A1	Not Taken
Test was conducted by: D. J. Somers Proof Director: D. H. Harksen (DJS)				

ROCK ISLAND ARSENAL
TEST AND EVALUATION RANGE REPORT NR. 67-178

DATE PREPARED: 3 April 1967	EX. ORDER NR: 54710-9003	TEST AUTHORIZED BY/COST CENTER/DATE: Memorandum/9310 CV/20 March 1967	PAGE 1	OF 2
MATERIEL TESTED: 105 mm. Cannon XM180 mounted with Adapter Assembly 67F885 in the M81E12 Recoil Mechanism in the M551 Vehicle.				
PURPOSE OF TEST: To obtain instrumented data to be used to evaluate the characteristics of the XM180 Cannon in its intended environment, check empty case ejection velocity, develop a <u>breech actuating cam.</u>				
FIXTURE AND/OR MATERIEL USED IN TEST: M551 Vehicle with an XM180, 105 mm. Cannon mounted into the recoil mechanism for the M81E12 Gun by Adapter Assembly 67F885.				
AMMUNITION COMPONENTS: Primer, Percussion M28B2 (300 Grain) Case, Cartridge, 105 mm. Howitzer M-14 Charge, Propelling M-67 Dualgran Ammunition Lot S.P. IA-61271 MP Lot IA-BR-61371 Projectile, Inert M-1 (33 lbs) Projectile, Disintegrating (S.S. 38 lbs)				
TEST PROCEDURE: Test Program Request No. RIA-9310-CV-200-3, dated 20 March 1967				
TEST DATA: Date of Test: 1 April 1967 Recuperator Nitrogen Pressure Direct 850 psi @ 68°F.				
<u>Round No.</u>	<u>Time</u>	<u>Charge-Prop (Zone-Type)</u>	<u>Recoil Length (Inches)</u>	<u>Chamber Pressure (psi)</u>
1	1:37	M-67 3	11 1/4	Not Taken
2	1:47	M-67 4	12 5/8	Not Taken
3	1:55	M-67 5	13 5/8	17,200
4	2:01	M-67 6	14 3/8	24,400
5	2:08	M-67 7	14 3/4	38,400
6	2:33	M-67 7	14 3/4	Not Taken
7	2:45	M-67 7	14 3/4	Not Taken
8	3:17	M-67 5	13 3/4	Not Taken
Installed automatic breech operating cam.				
(Continued)				

TEST AND EVALUATION RANGE REPORT NO. 67-178

Page 2 of 2

<u>Round No.</u>	<u>Time</u>	<u>Charge-Prop (Zone-Type)</u>	<u>Recoil Length (Inches)</u>	<u>Chamber Pressure (psi)</u>
9	3:24	M-67 6	14 3/8	Not Taken
10	3:31	M-67 6	14 3/8	Not Taken
11	3:33	M-67 7	14 5/8	37,400

Date of Test: 3 April 1967

Recuperator Nitrogen Pressure Direct 850 psi @ 58°F.

12	8:37	M-67 5	13 1/4	Not Taken
13	8:50	M-67 6	13 3/4	Not Taken
14	10:00	M-67 7	13 7/8	Not Taken
15	10:15	M-67 7	14 7/8	Not Taken
16	10:39	M-67 7	14 7/8	Not Taken

The following rounds were disintegrating projectiles fired at 258 mils elevation.

17	12:42	M-67 7	14 1/8	Not Taken
18	12:53	M-67 7	14 7/8	Not Taken
19	1:04	M-67 7	14 7/8	Not Taken

This concluded the firing of this test.

Test conducted by: D.J. Somers
 Proof Director: D. H. Harksen (DJS)

ROCK ISLAND ARSENAL
TEST AND EVALUATION RANGE REPORT NR. 67-194

DATE PREPARED:	EX. ORDER NR:	TEST AUTHORIZED BY/COST CENTER/DATE:	PAGE	OF
8 April 1967	54710-9003	Memorandum/9310 CV/20 March 1967	1	1
MATERIEL TESTED: 7.62 mm. Machine Gun M-73, Serial #2041, Manufacture Springfield Armory. Fired in this application from M551 Vehicle.				
PURPOSE OF TEST: To determine if weapon fires satisfactorily in this application.				
FIXTURE AND/OR MATERIEL USED IN TEST: 7.62 mm. Machine Gun M-73, Serial #2041, Manufacture Springfield Armory. M551 Vehicle				
AMMUNITION COMPONENTS: Nato 7.62 mm., Ball M-80 Lot FC-1869				
TEST PROCEDURE: Test Program Request No. RIA-9310-CV-200-3, dated 20 March 1967				
TEST DATA: Date of Test: 3 April 1967 Weapon mounted 45° clockwise from normal position for worst feed condition. Weapon fired with one hundred round belt straight through. Test was conducted by: J. Gelvin Proof Director: D. H. Harksen (DJS)				

APPENDIX D

TEST DATA



ROUND 8 ZONE 7, M3
 105 MM M103E7 GUN ADAPTED TO THE
 RECOIL MECHANISM FOR THE 152 MM M101E2
 WEAPON
 17 MAR 1967

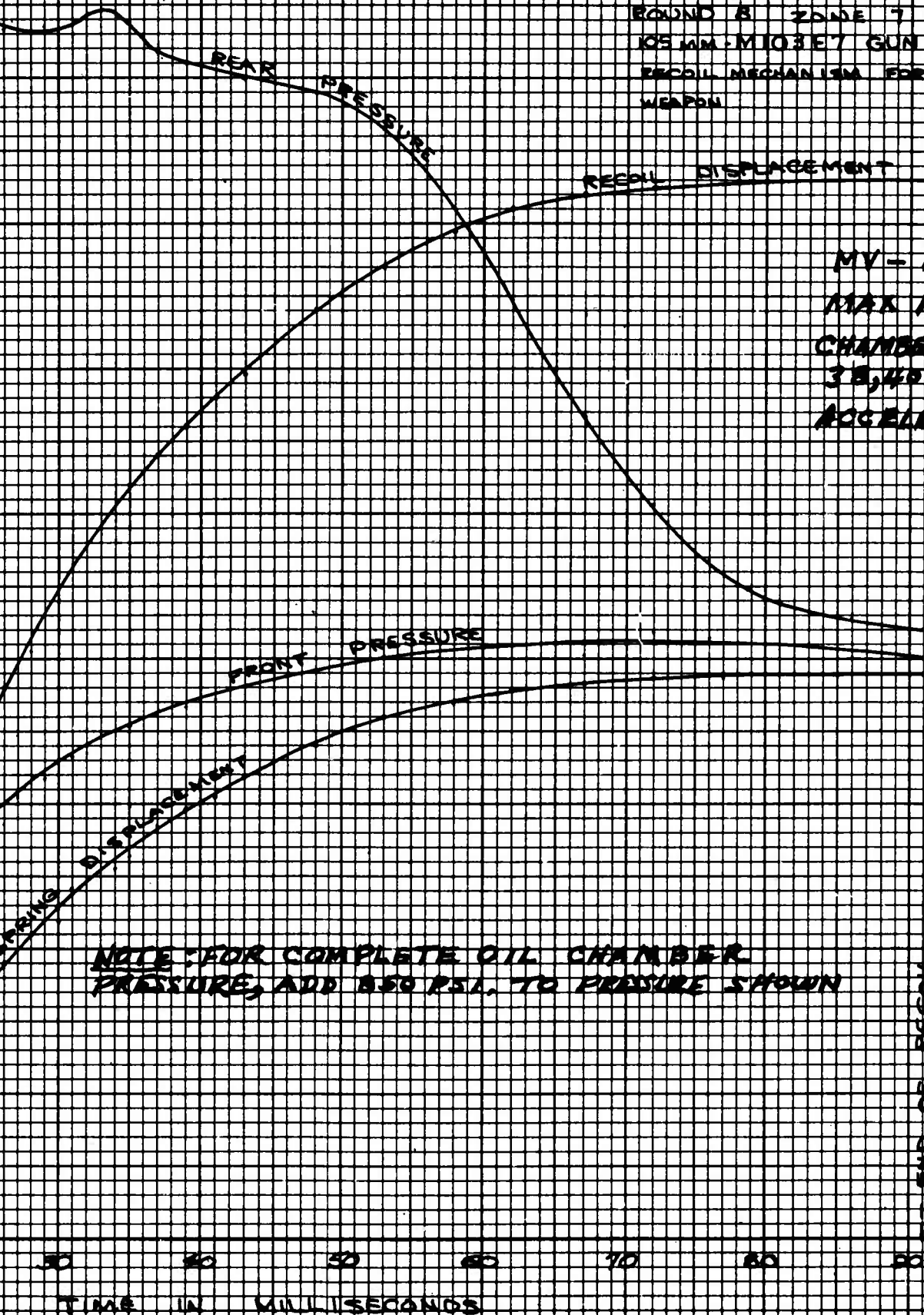

MV = 1538 $\frac{ft}{sec}$
 MAX HOP 4 $\frac{1}{16}$ IN.
 CHAMBER PRESSURE
 38,400 PSI.
 ACCELERATION 500 G

NOTE: FOR COMPLETE OIL CHAMBER
 PRESSURE, ADD 850 PSI. TO PRESSURE SHOWN

RECOIL

50 60 70 80 90 100
 TIME IN MILLISECONDS

2

RECORD OF M137E1 CANNON IN AUX. GUN MT.

ROUND NO. 8

ZONE-7

DATE- 11 MAR. 67

FRONT OIL PRESSURE

REAR OIL PRESSURE

500 GS

ACCELERATION

BUFFER MOTION

SPRING MOTION

T-D OF RECOILING PARTS

VELOCITY- MUZZLE

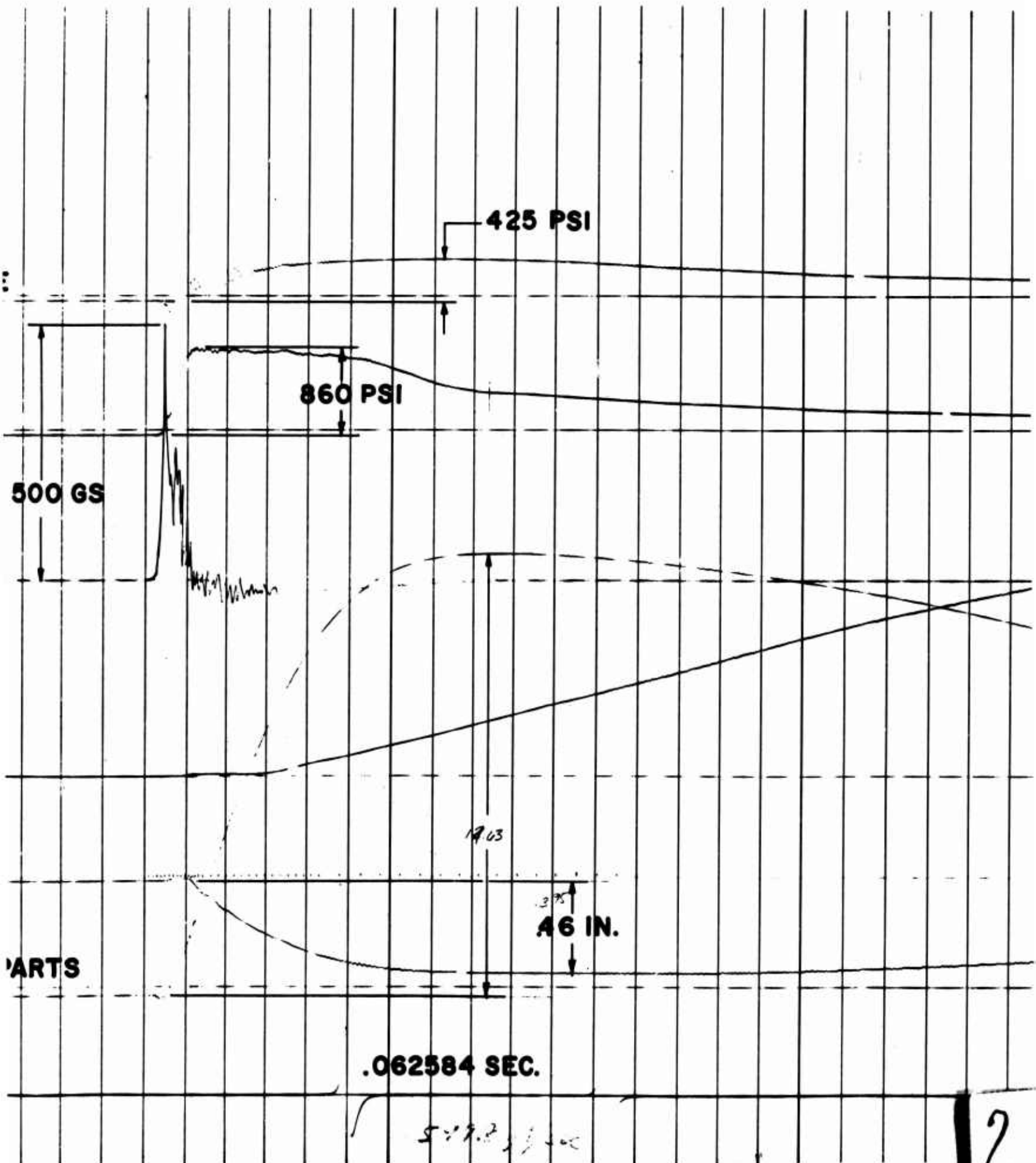

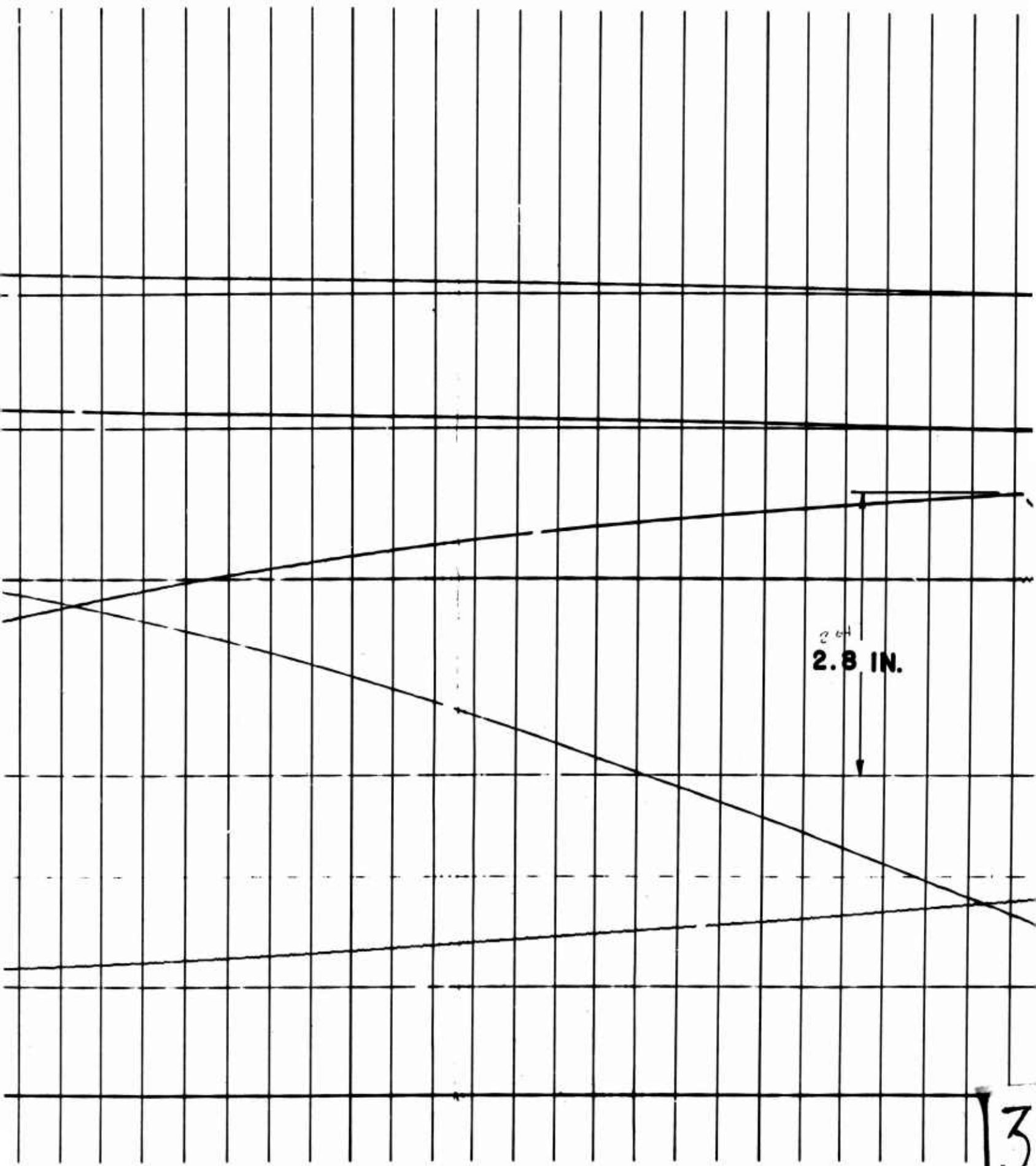

^{e h}
2.8 IN.

3

A hand-drawn diagram on graph paper. The graph has a grid of 20 vertical lines and 10 horizontal lines. A curve is drawn, starting from the left edge, rising to a peak at approximately the 10th vertical line, then falling to a minimum at approximately the 15th vertical line, and finally rising again towards the right edge. A vertical dimension line is drawn between the 10th and 11th horizontal lines, with a downward-pointing arrow at the bottom. The text "2.8 IN." is written next to the dimension line. There is a small handwritten mark above the "2".

^{2.64}
2.8 IN.

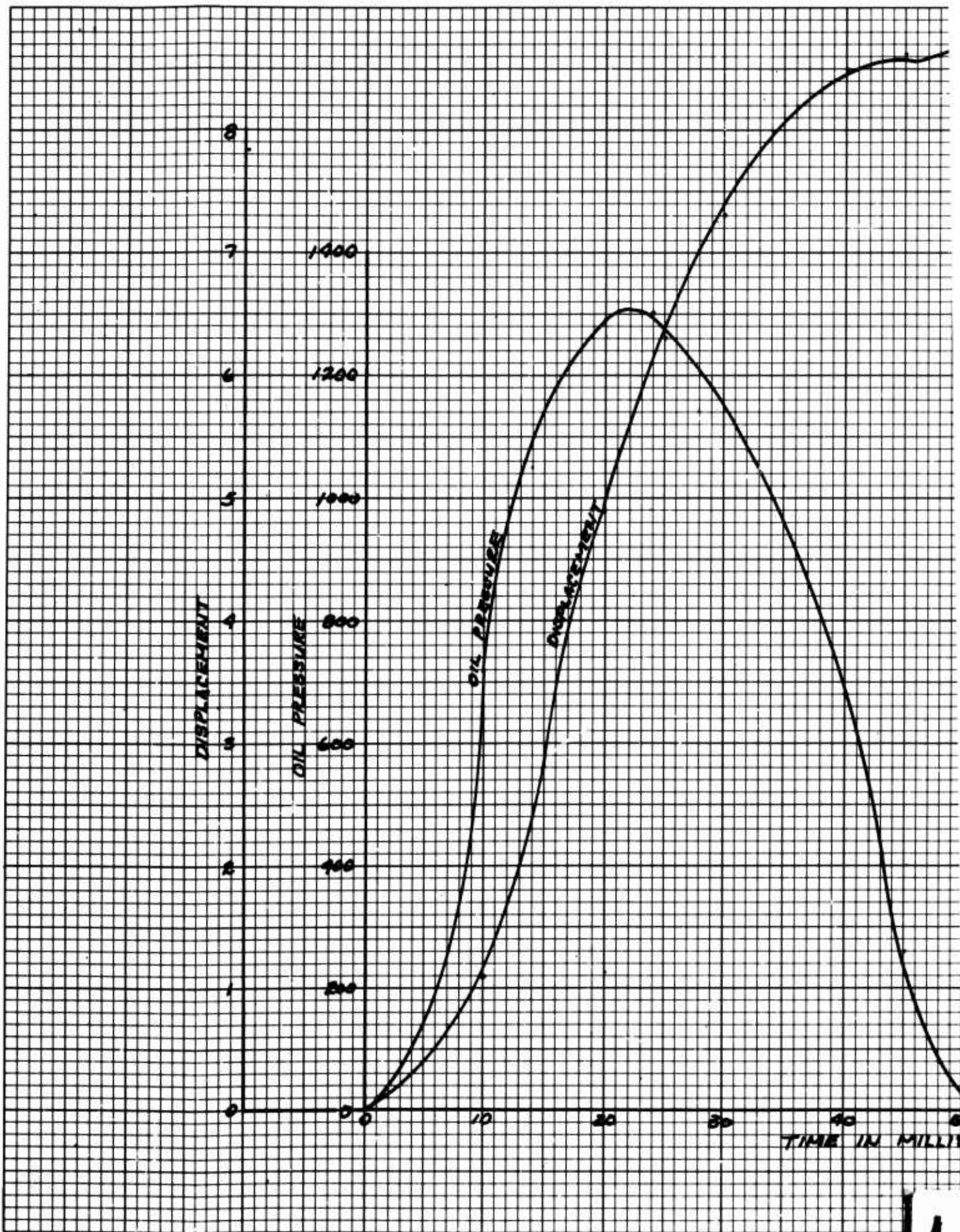

ROUND # 3-21-67
M52 CANNON, M76 MOUNT
76 MM SEMI-AUTO BREACH
RD. TPT340A1

CHAMBER PRESSURE
ESTIMATED 4-4,800 PSI.
MAX HOP = 6 1/2 IN.
ACCELERATION = 240 G

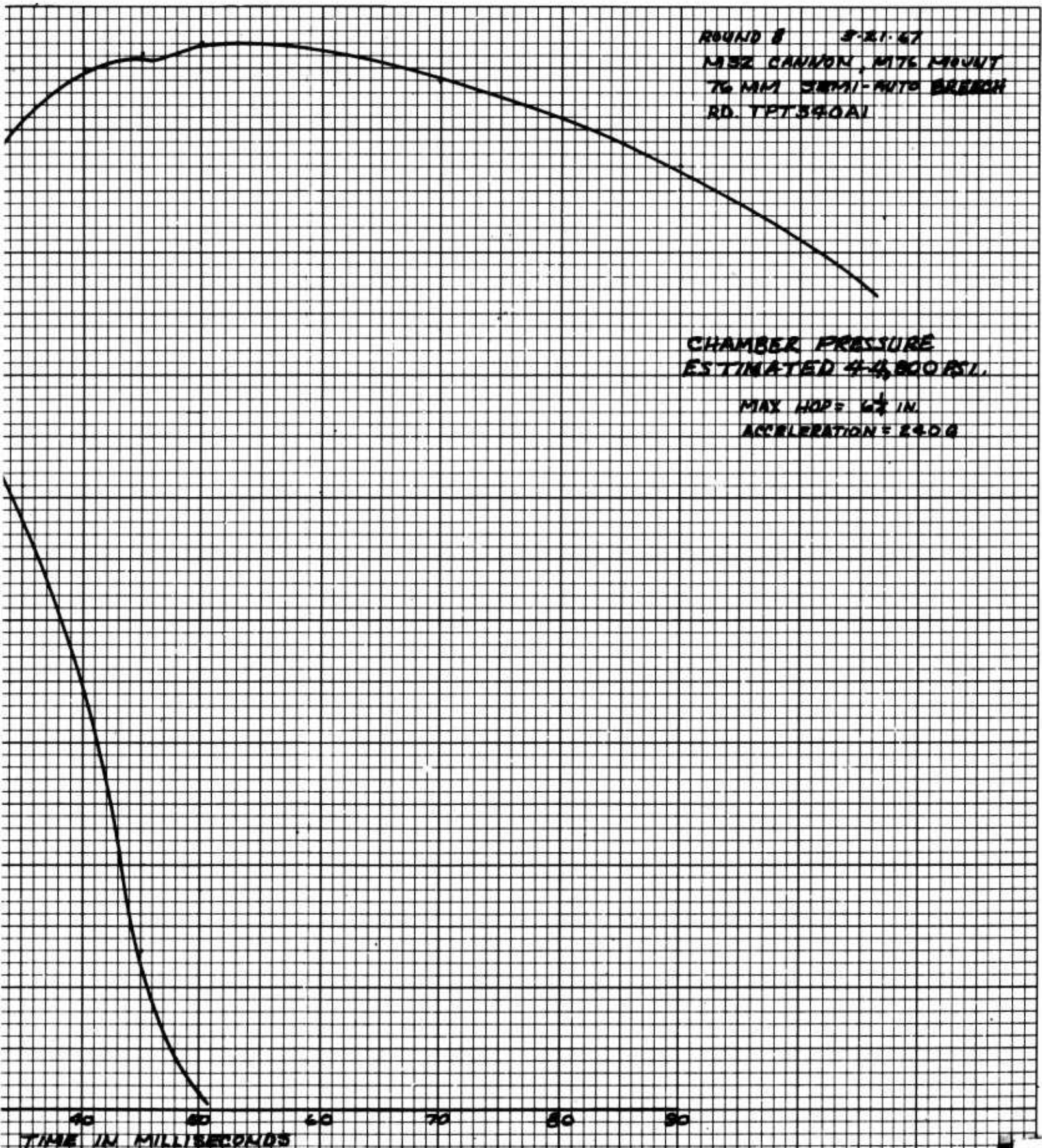

40 50 60 70 80 90
TIME IN MILLISECONDS

2

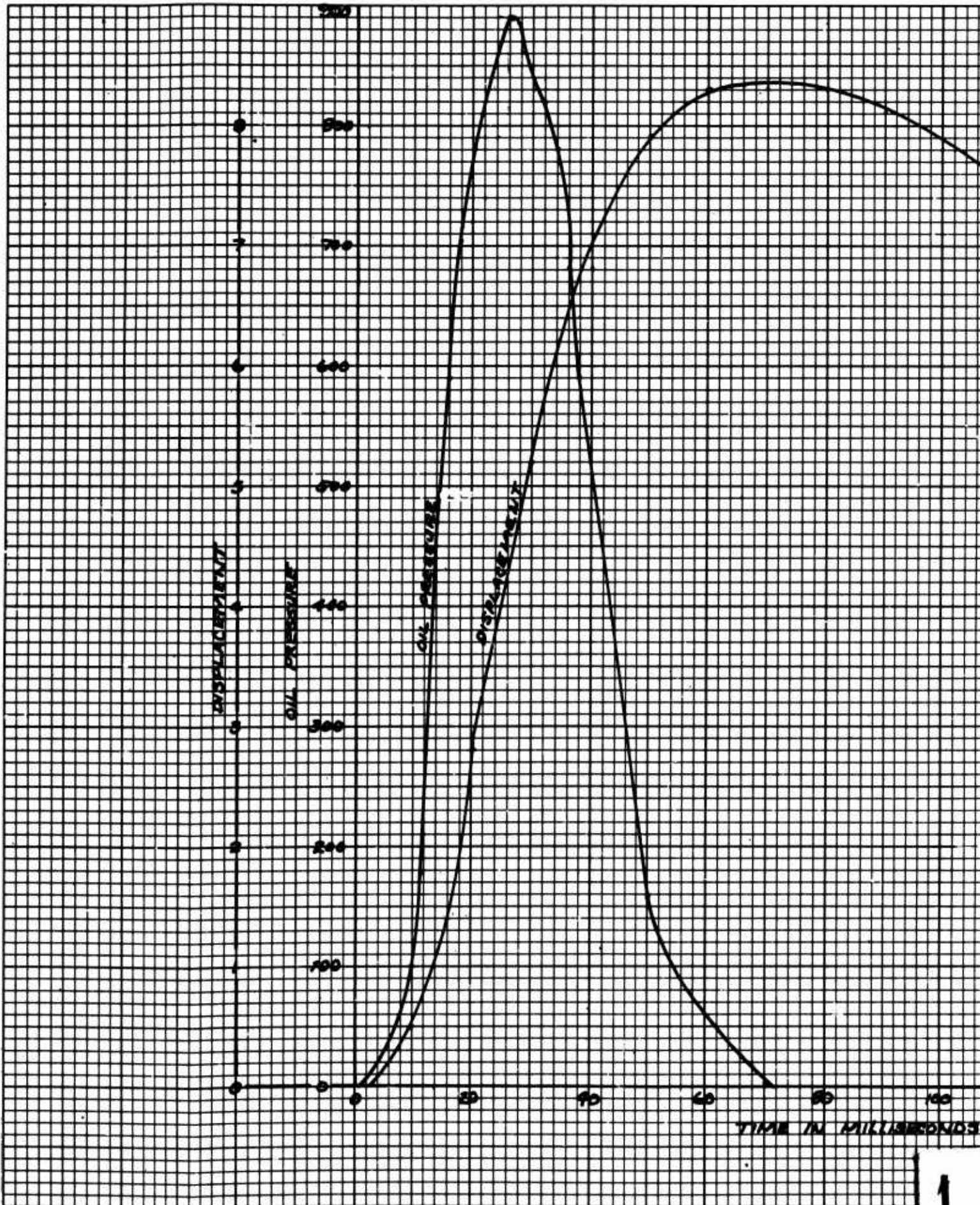

ROUND # 3-21-67
M152 CANNON, M176 MOUNT
7/8 M14, SEMI-AUTO BRNCH
RD: M152

MV = 2901 FT/SEC.
MAX HOP = $5\frac{1}{8}$ IN.

CHAMBER PRESSURE
ESTIMATED 28,500 PSI.

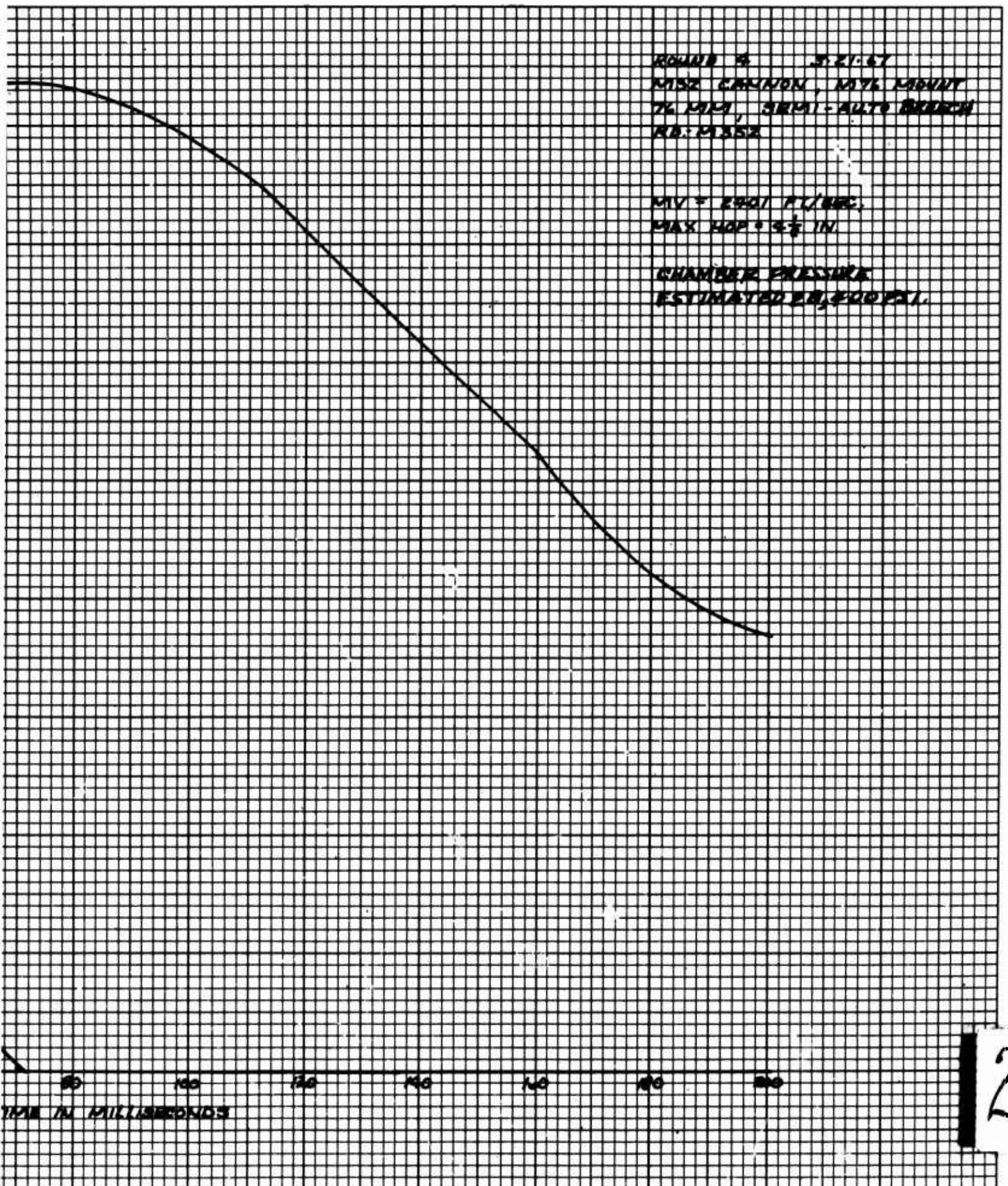

2

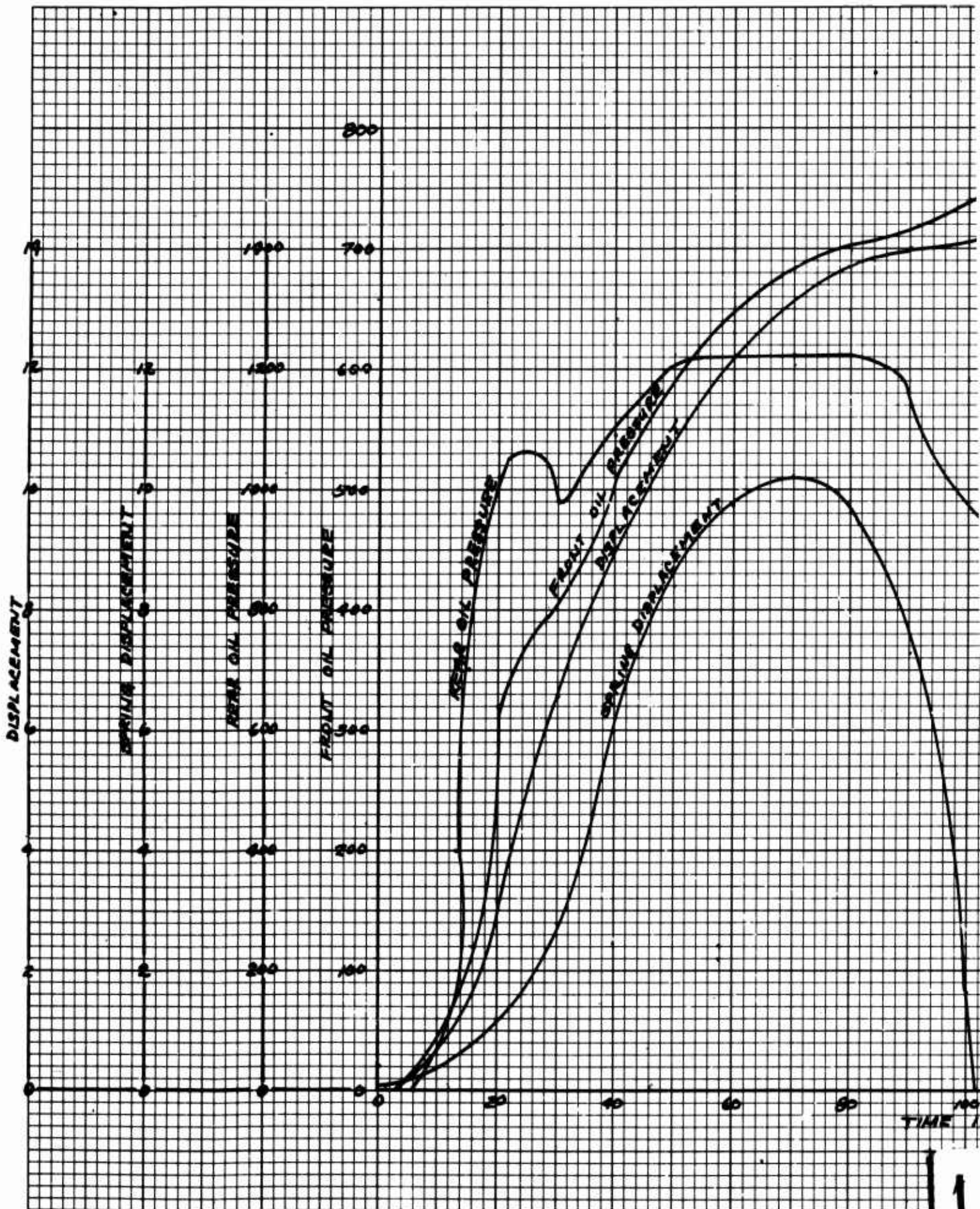

ROUND 11 3-29-67
H BE CANNON, SHILLERSON MT.
76 MM, MANUAL BRUSH

MV = 5125 FT./SEC.
MAX HOPE = 5 1/2 IN.
EST. CHAM. PRESSURE 44,000 PSI.

NOTE: FOR COMPLETE OIL PRESSURE, ADD THE
850 PSI. PREPRESSURE

90 100 110 120 130 140 150 160 170 180 190
TIME IN MILLISECONDS

2

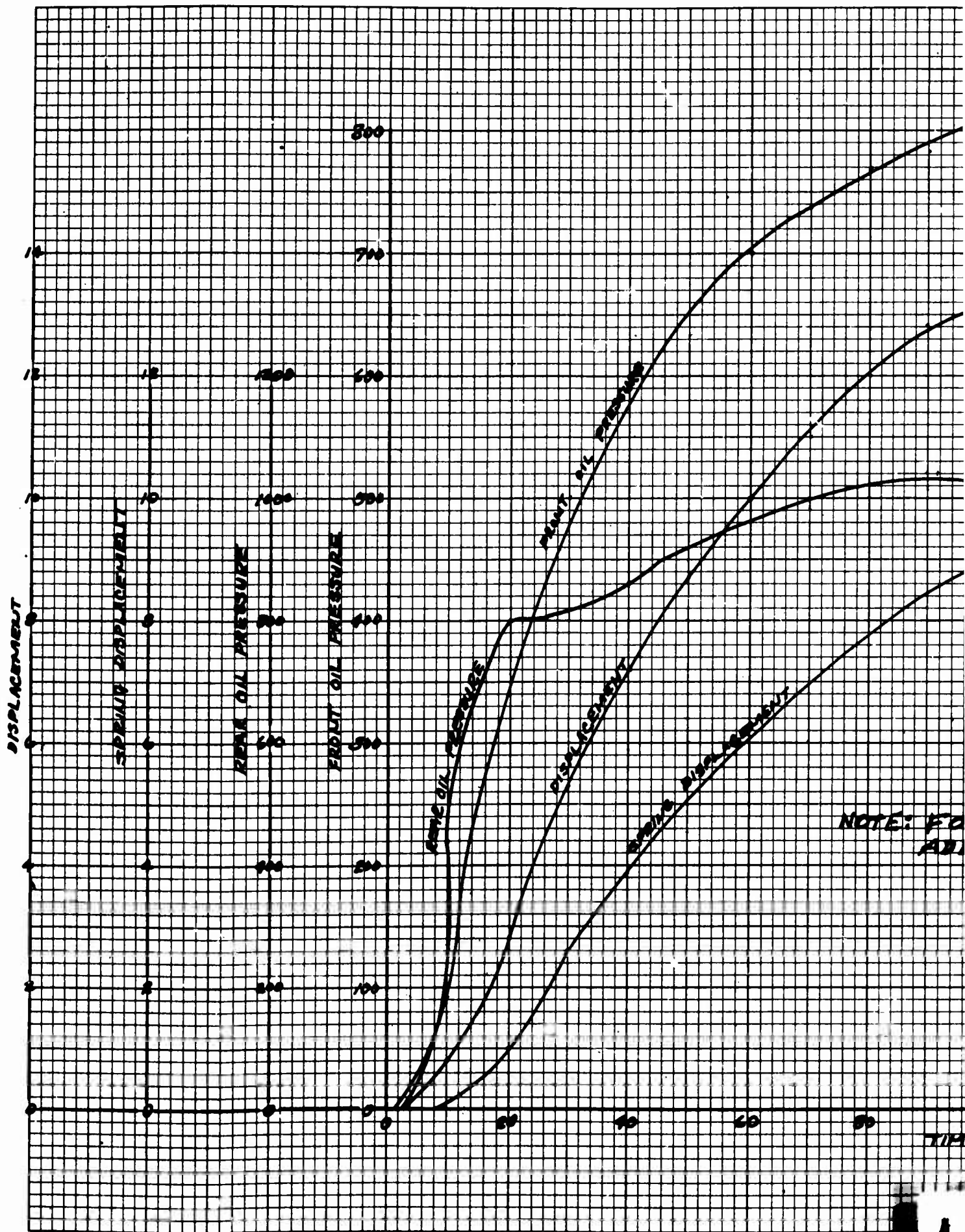

FIGURE 6 3-24-67
M32 CANNON, SHILLINGHAM AT
76 MM, MANUAL BURSTON
EST. CHAM. PRESSURE 20,000 PSI.

MVE 2880 FT./SEC.
MAX HOPE 3 7/8 IN.

NOTE: FOR COMPLETE OIL PRESSURE,
ADD THE 850 PSI. PREPRESSURE

2

50 100 150 200 250 300 350 400
TIME IN MILLISECONDS

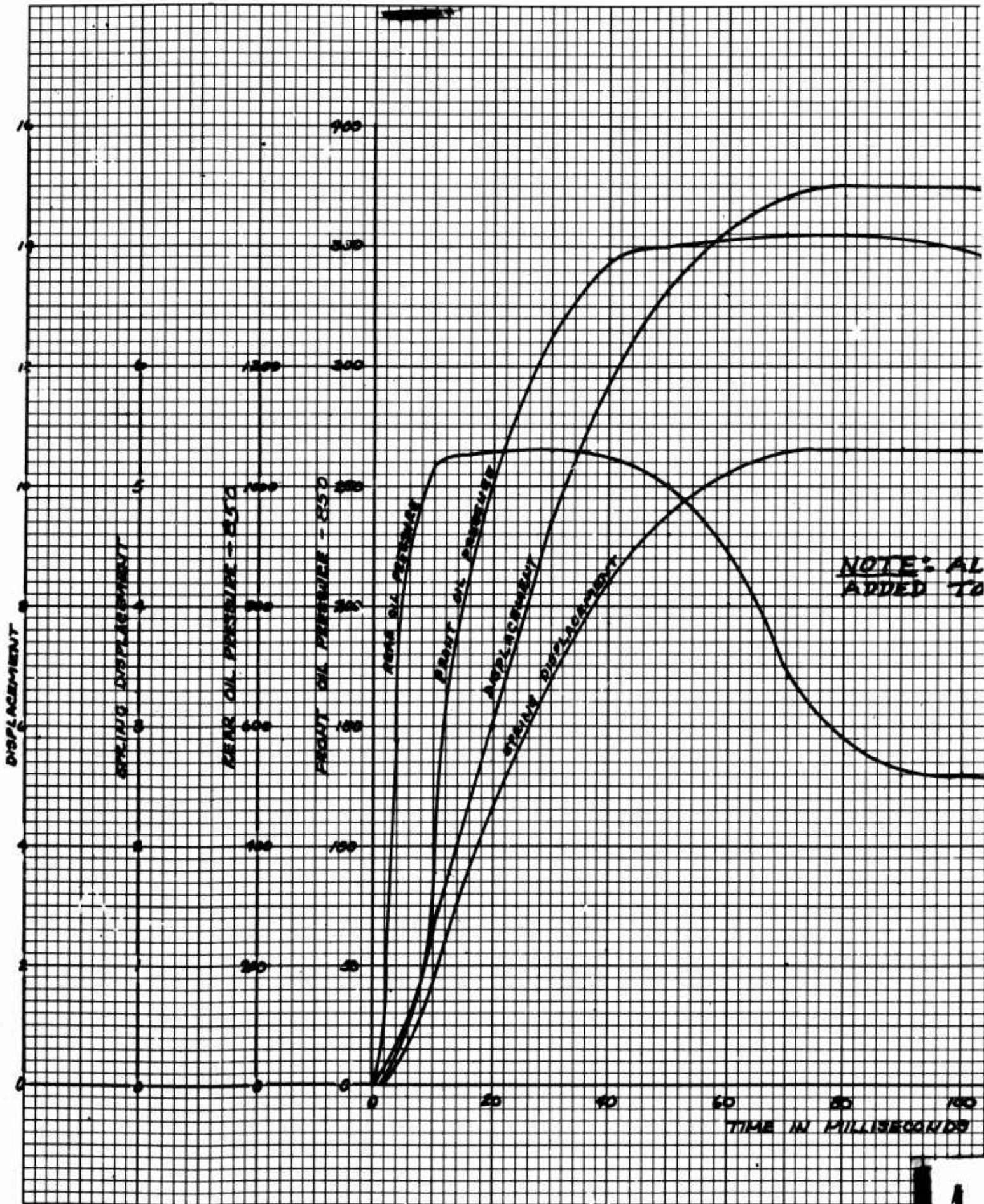

ROUND 16 4.3.67
XMIED CANALON
105MM ZONE 7
SEMI-AUTO BENCH

MY=1602 FT. 1580.

NOTE: ALL OIL PRESSURES MUST BE
ADDED TO THE 650 P.S.I. PREPRESSURE

20 100 120 140 160 180 200
MILLISECONDS

2

RD #16
Z-7
105MM CANNON
M551 VEHICLE
4-3-67

E. OIL

3000

2000

R. OIL

ACCEL

SPRING MOTION

T-D

MAG

1000 Hz

VELOCITY

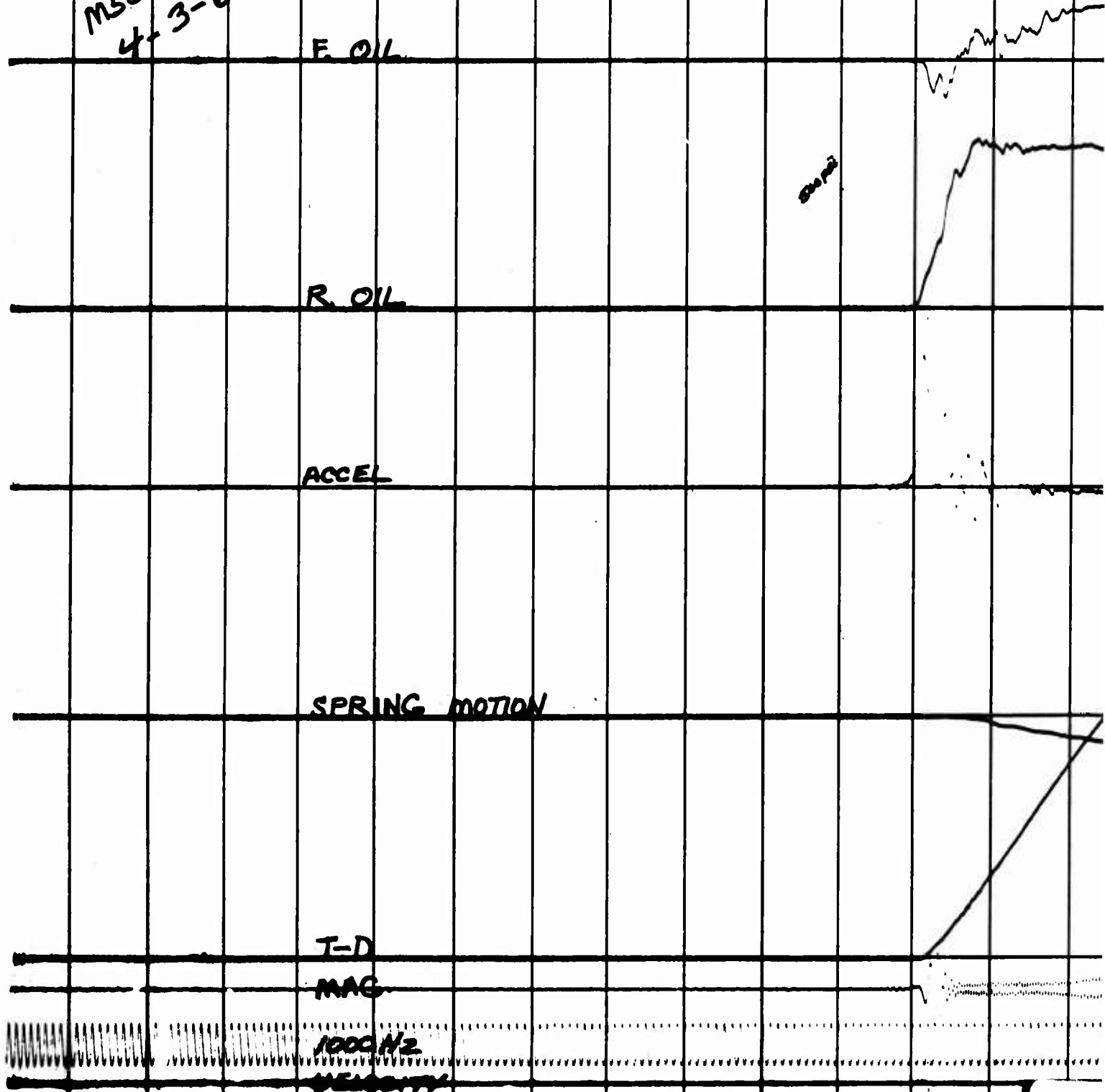

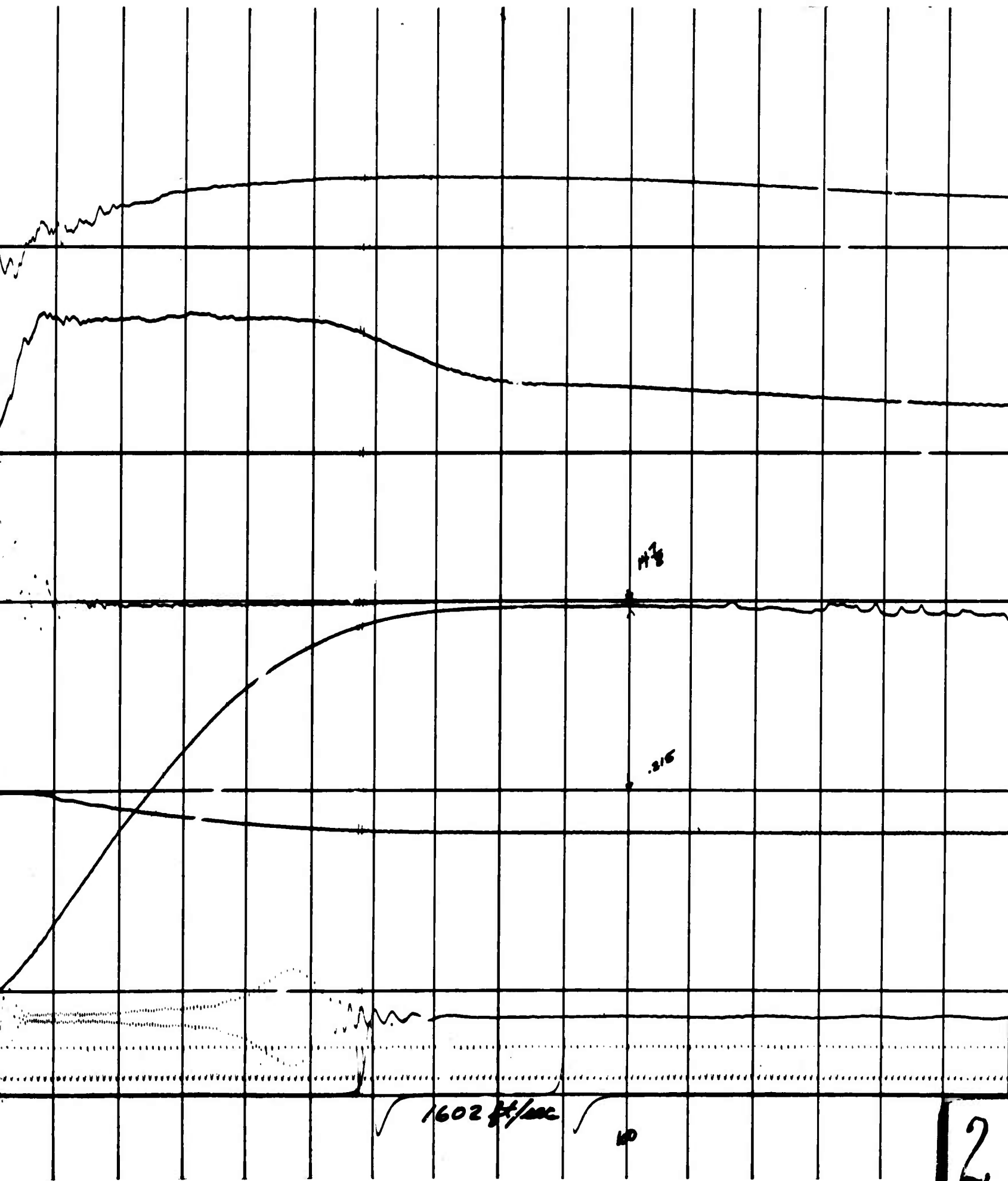

S
P
LE

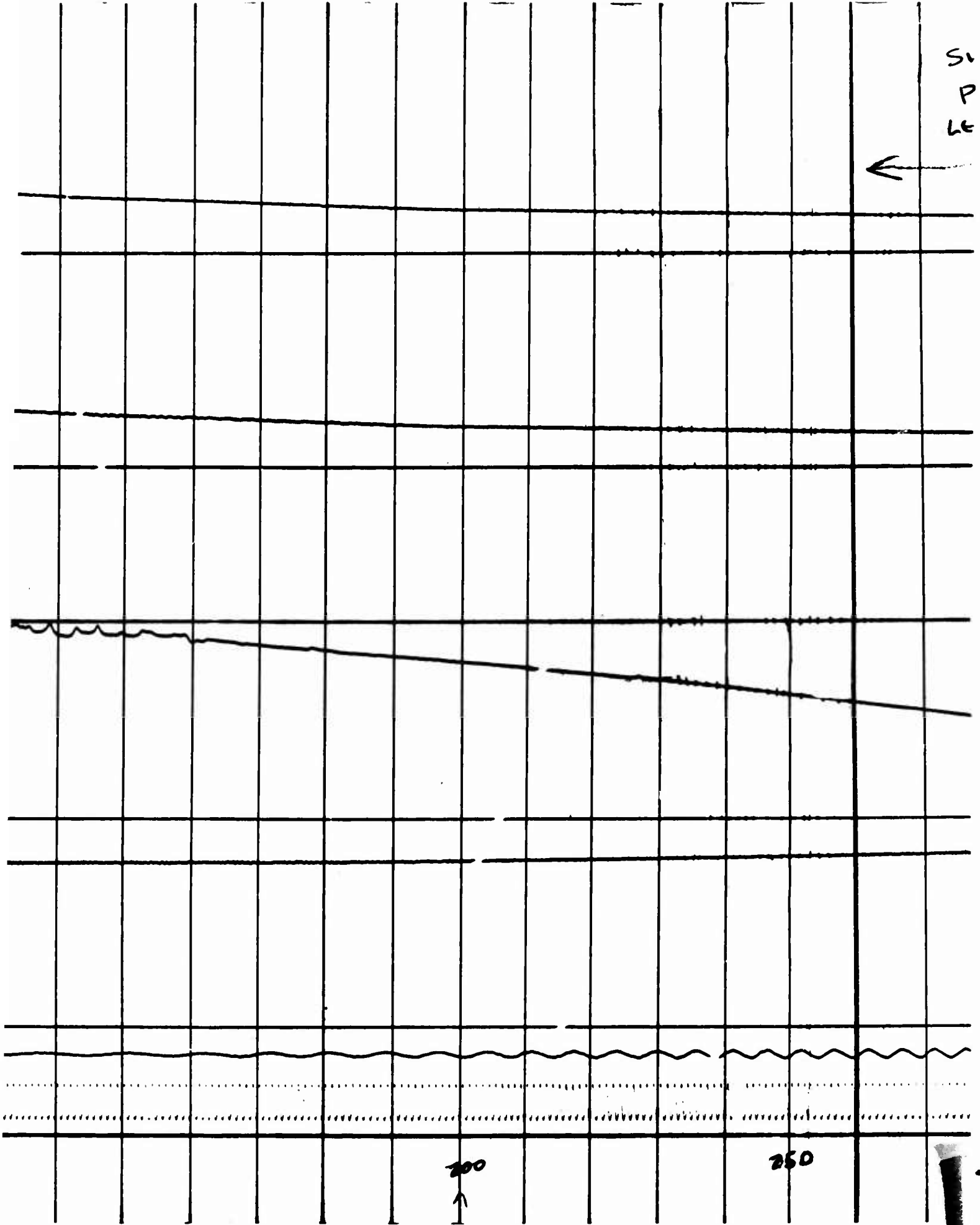

200
↑

250

3

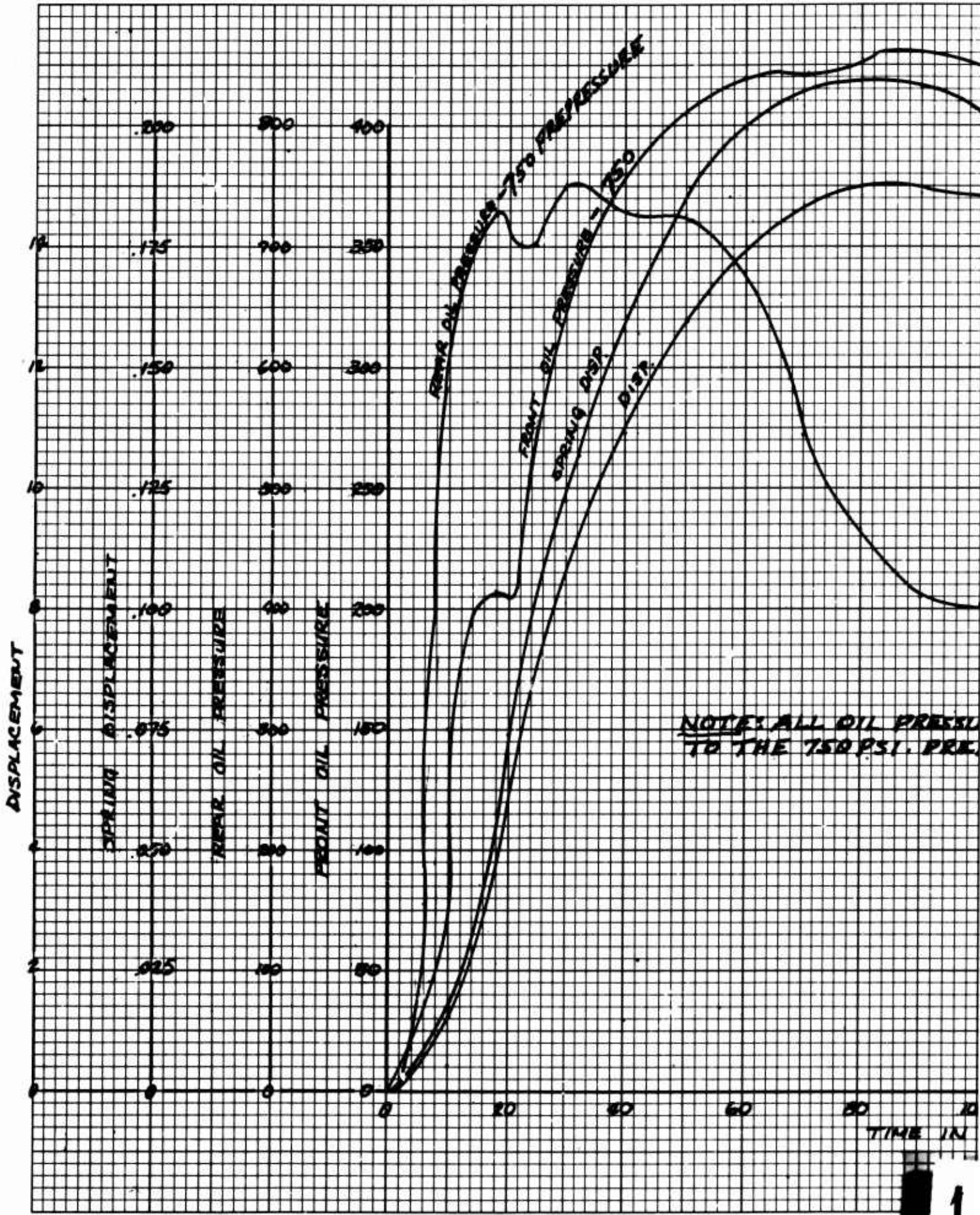

NOTE: ALL OIL PRESSURE TO THE 750 PSI. PRE.

ROUND 13 3 APRIL 67
XM/80 GAJAHN
705 MPN SEMI-HYD BEECH
DISINTEGRATING RD. = ZONE 7

$14\frac{1}{2}^{\circ}$ QUADRANT ELEVATION
MAX. HOP $\frac{4}{8}$ IN.

L OIL PRESSURES MUST BE ADDED
150 PSI. PREPRESSURE FOR ACTUAL PRESSURE

80 100 120 140 160 180 200 220 240
TIME IN MILLISECONDS

APPENDIX E

DRAWINGS

The following drawings are included for reference purposes:

<u>Drawing No.</u>	<u>Title</u>
RIA 137132 (Sheet 1)	Adapter
RIA 137152	Adapter Assembly
RIA 137155	M103 Cannon Auxiliary Gun Mount
RIA 137167	Shield, Gun
67K658	Adapter
67F655	Adapter
67F738	Gun Combination Mount
67D768	Adapter
67F885	XM180 Adapter Assembly
67F912	Bracket Assembly
67D934	Cam Assembly
67F1026	Lever Assembly

REV 1005 BRECH

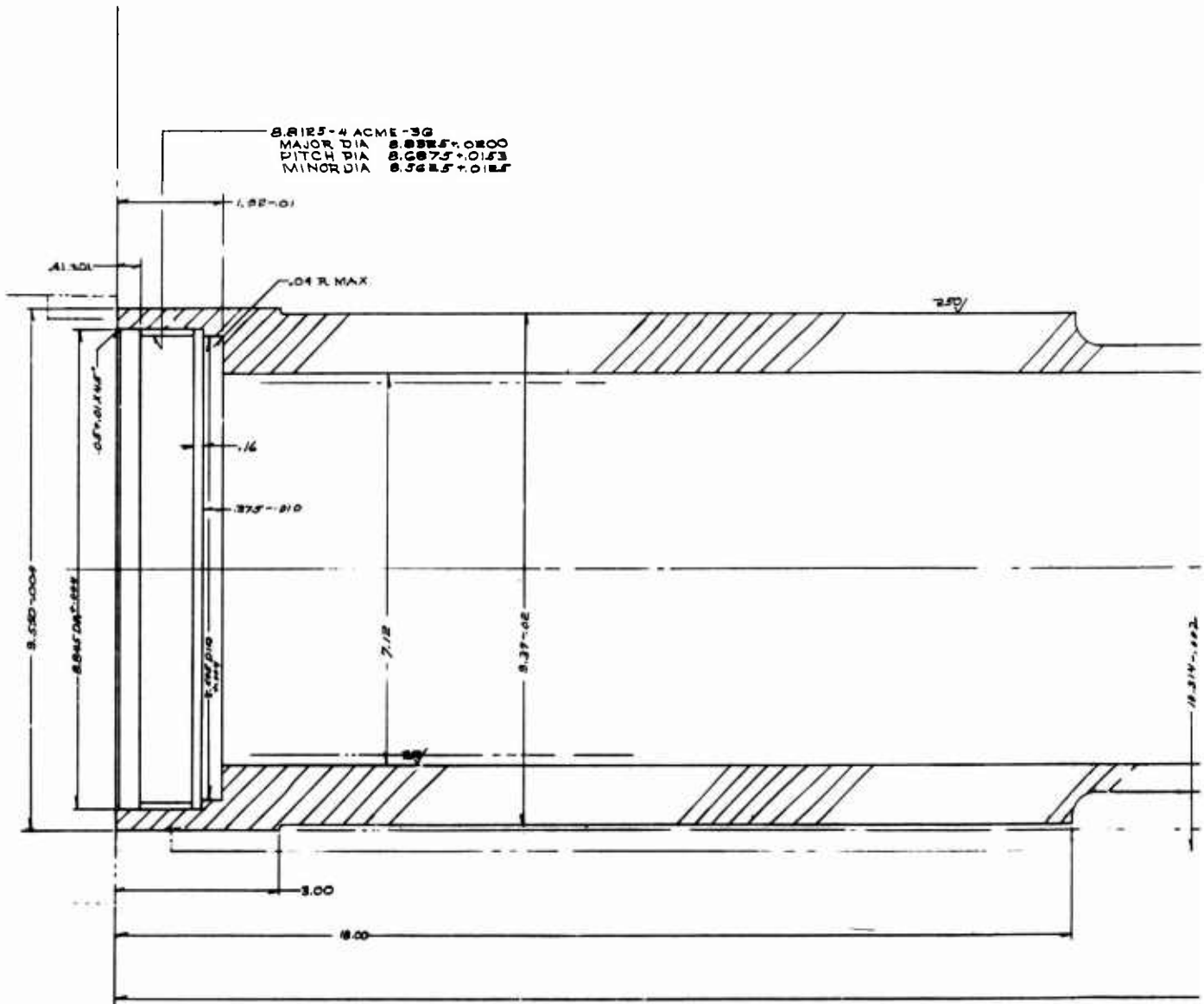

1

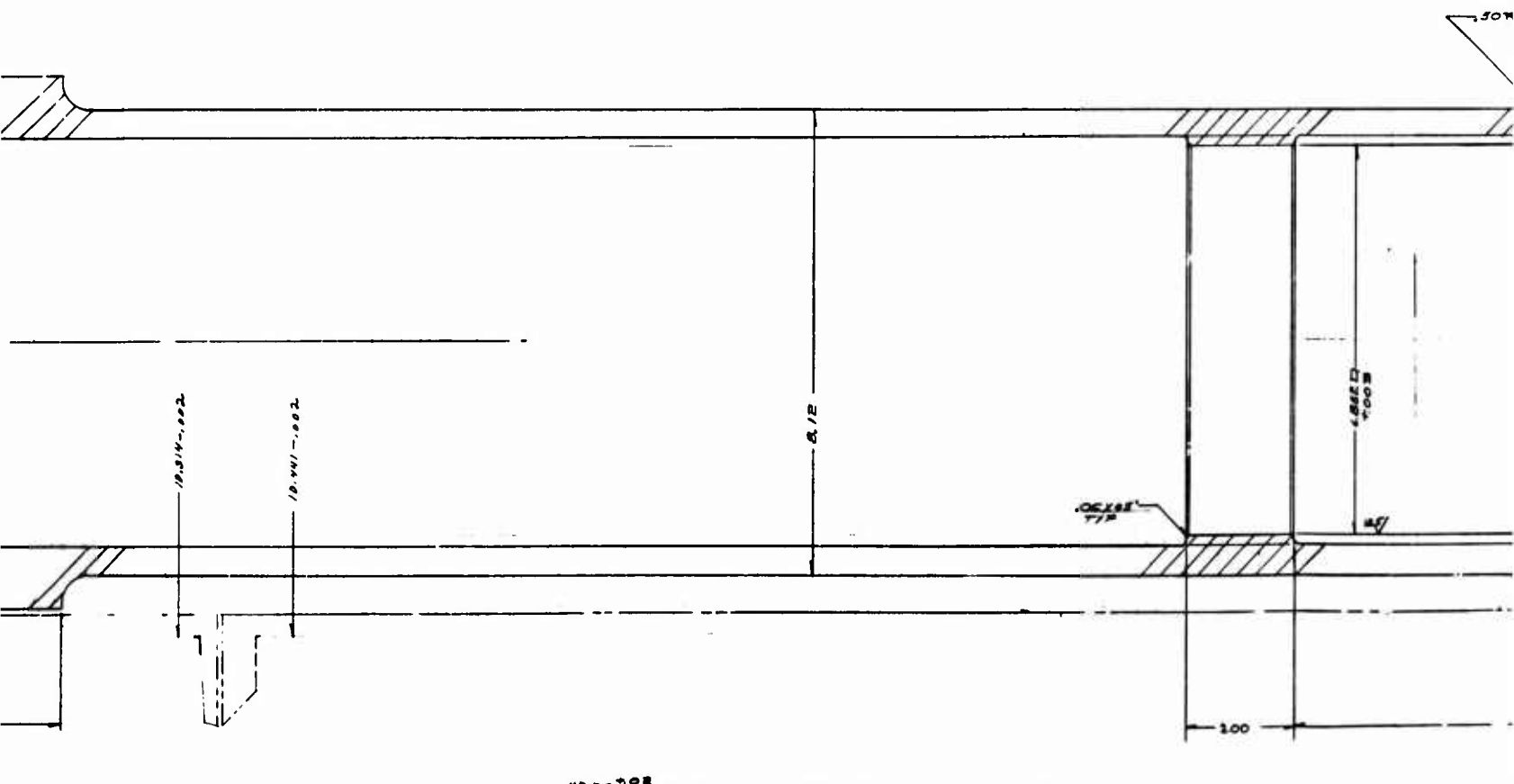

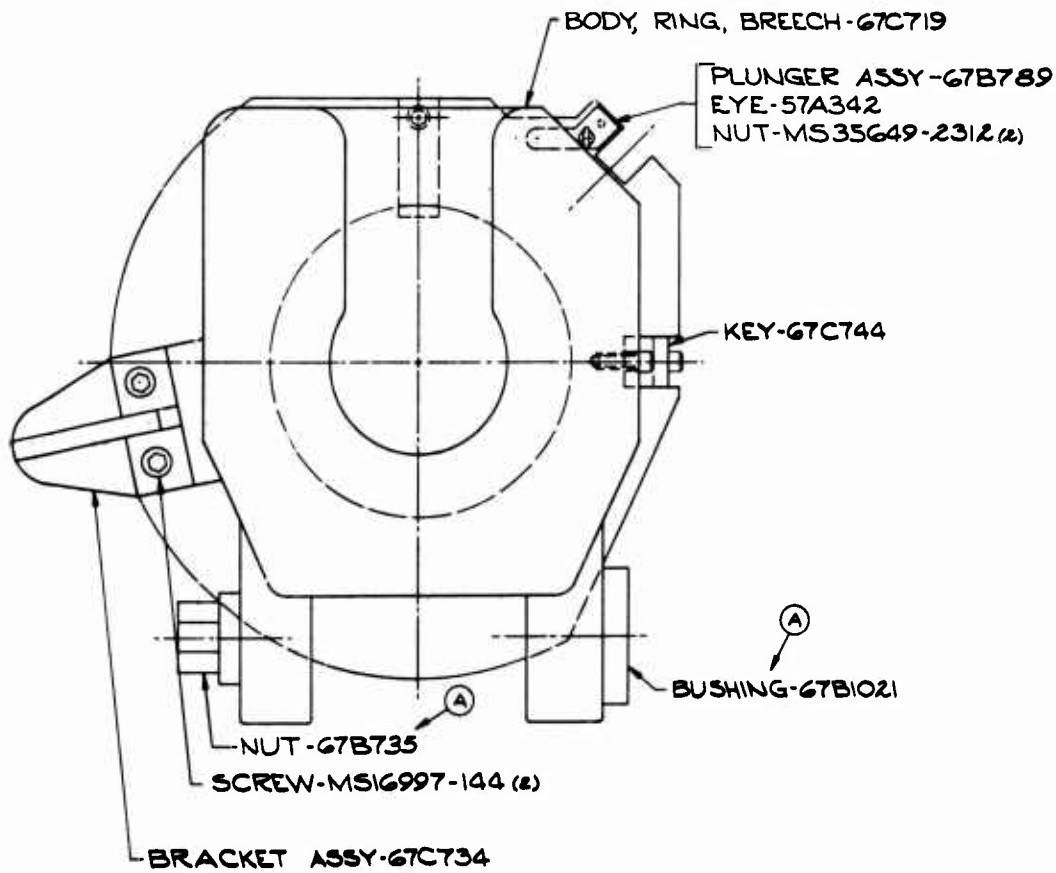
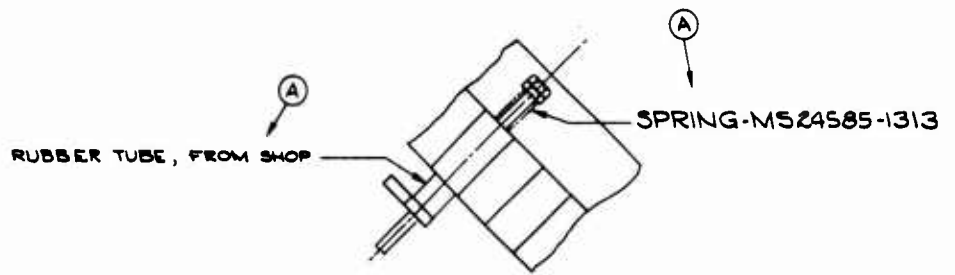

SCREW-MS1699

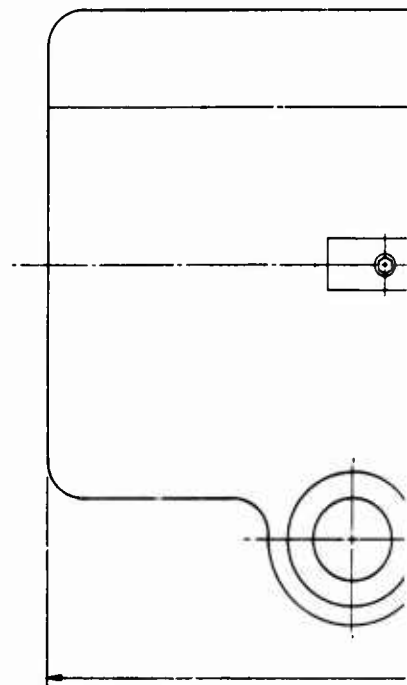

35-1313

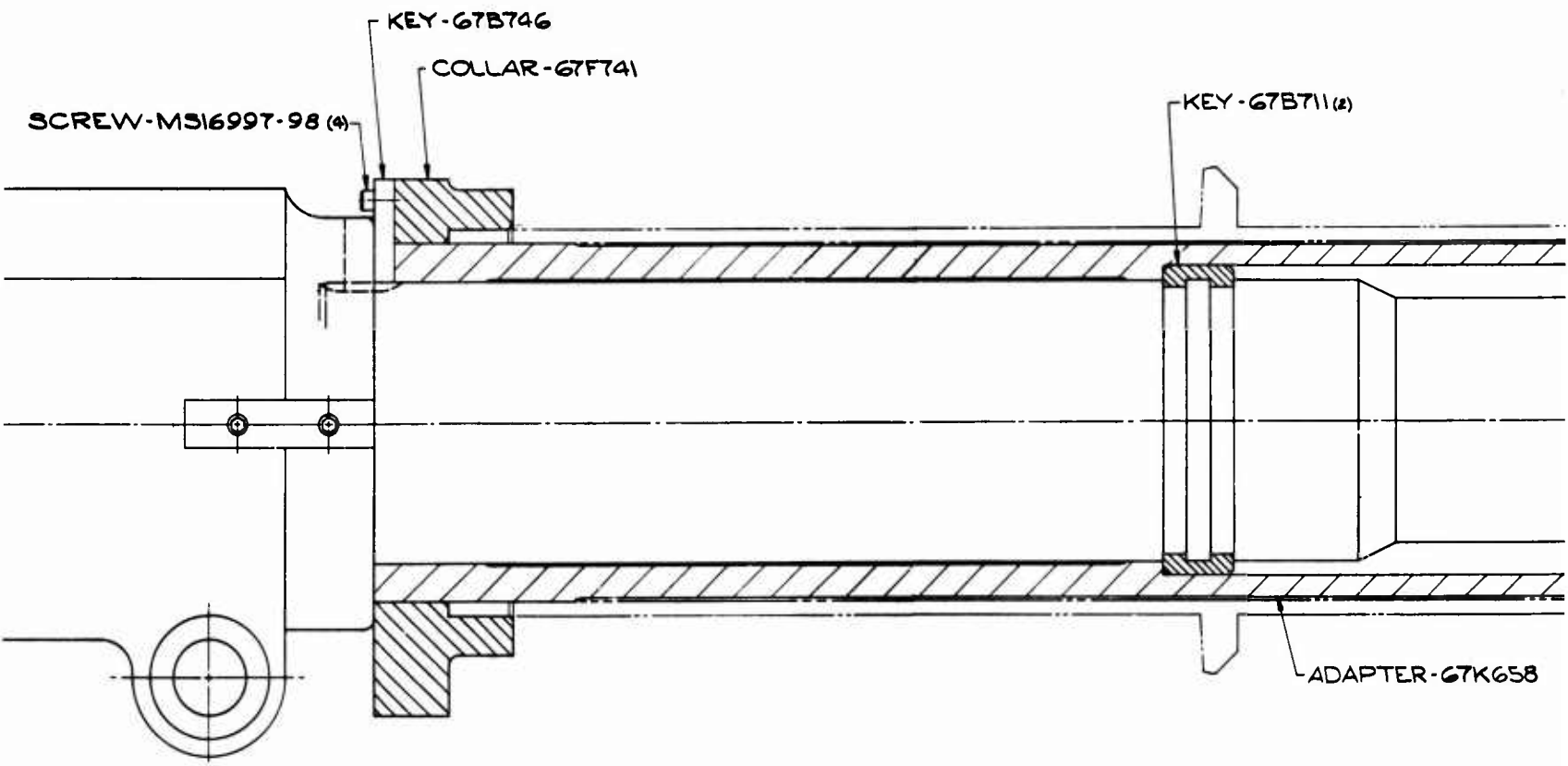

54.112

2

67B711(2)

LOCK - C8769612

COLLAR - 67C671

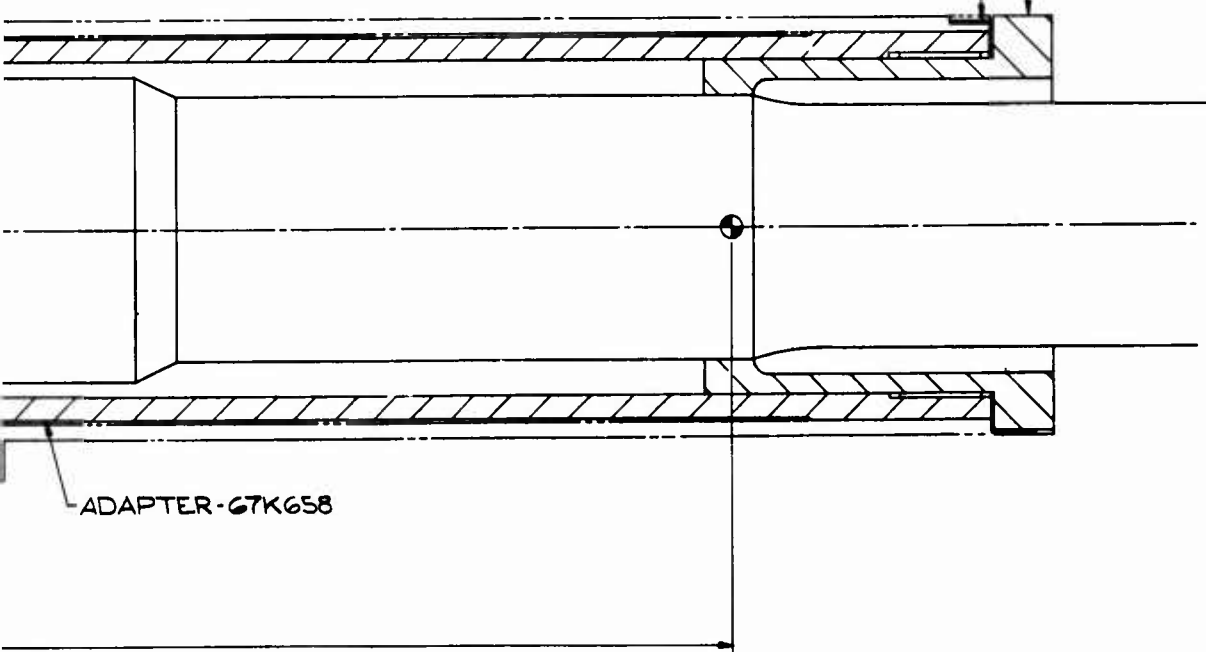

ADAPTER - 67K658

13

ADAPTER ASSY			
MAR 10, 1967	REFERENCE	M32 ADAPTER ASSY	
A	MAR 27, 1967	DRAFTER AND CHECKER	APPROVED
		<i>[Signature]</i>	<i>[Signature]</i>
SCALE 1/2	SKETCH NUMBER	SHEET OF SHEETS	
	RIA 137152	3	
ROCK ISLAND APPROVAL			

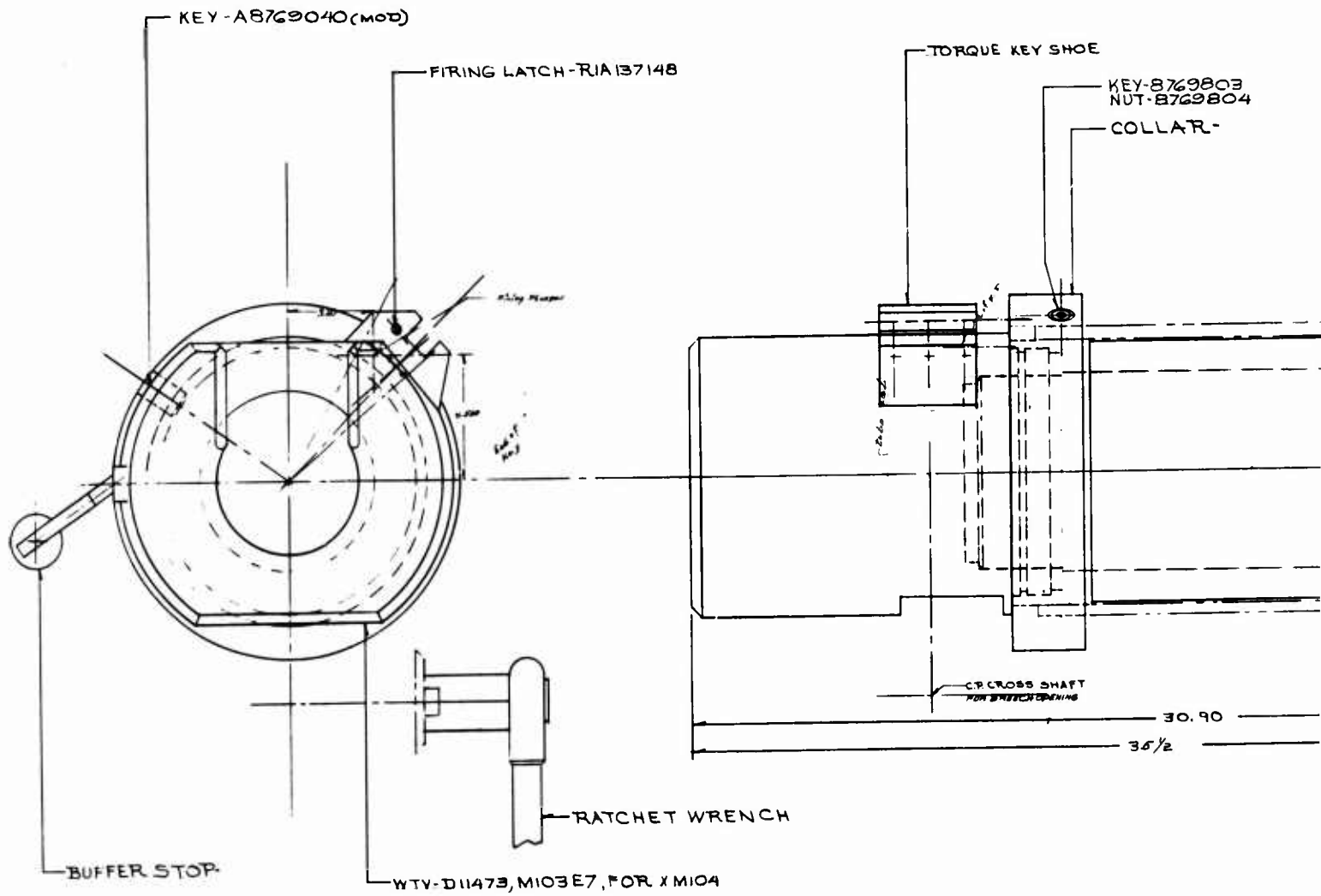

1

E

- KEY-8769803
- NUT-8769804
- COLLAR-

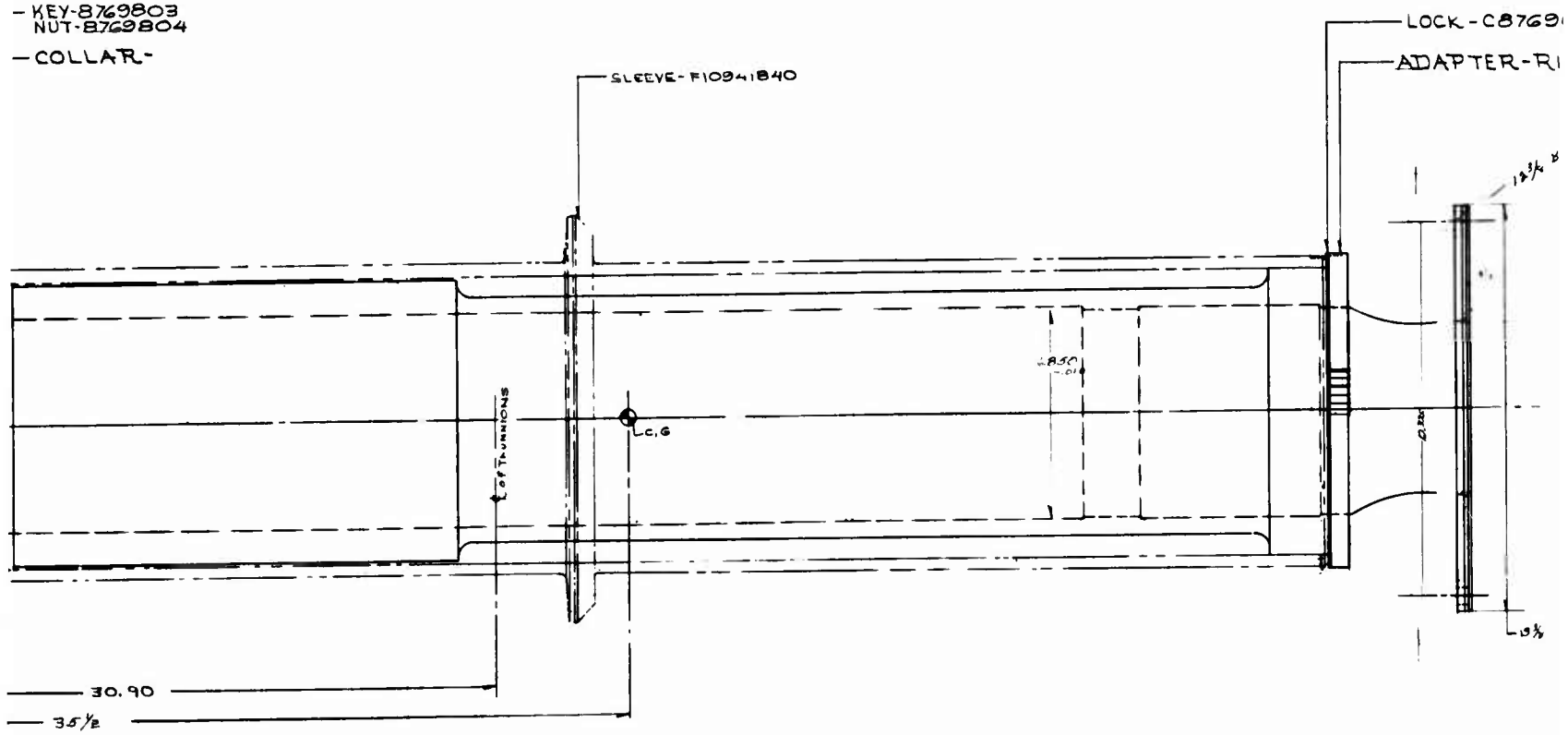

12

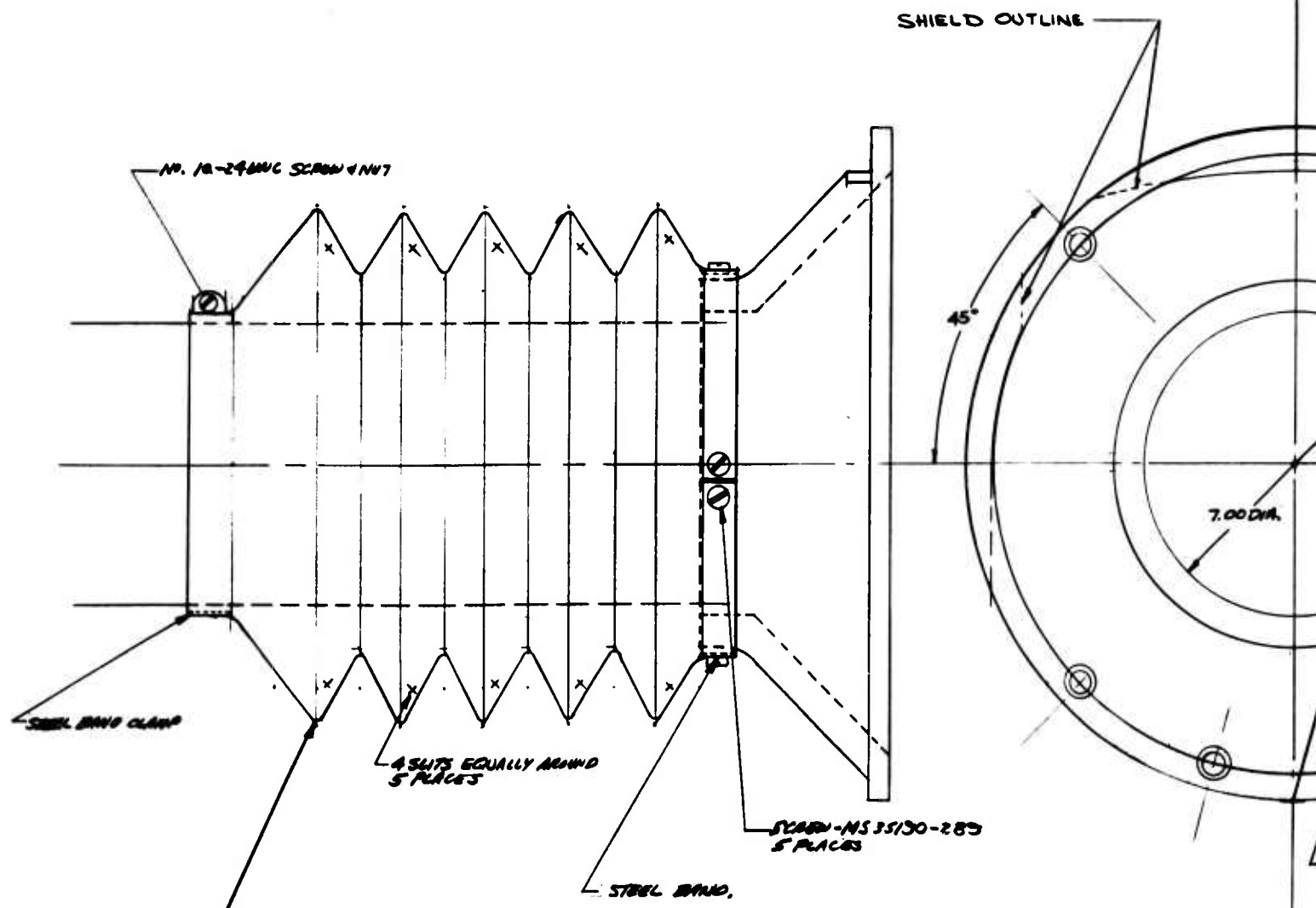
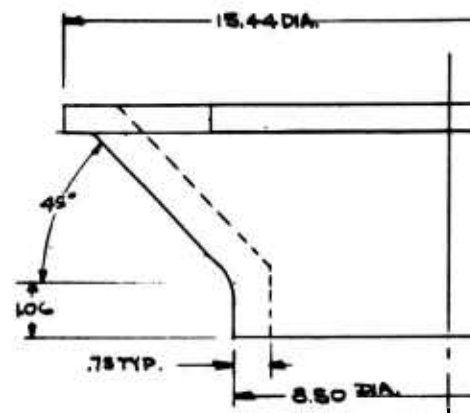

DUST COVER
 - CLOTH, COATED, NYLON, WATER PROOF
 TYPE II, CLASS 3, .1702/50. YA
 MIL-C-20696 & 62A 1GAA
 MACHINE STITCHING TO BE
 SEWED WITH SIZE FF NYLON
 THREAD, MIL-T-7807, 7 STITCHES
 TO THE INCH, IN ACCORDANCE
 WITH DDD-8-751.

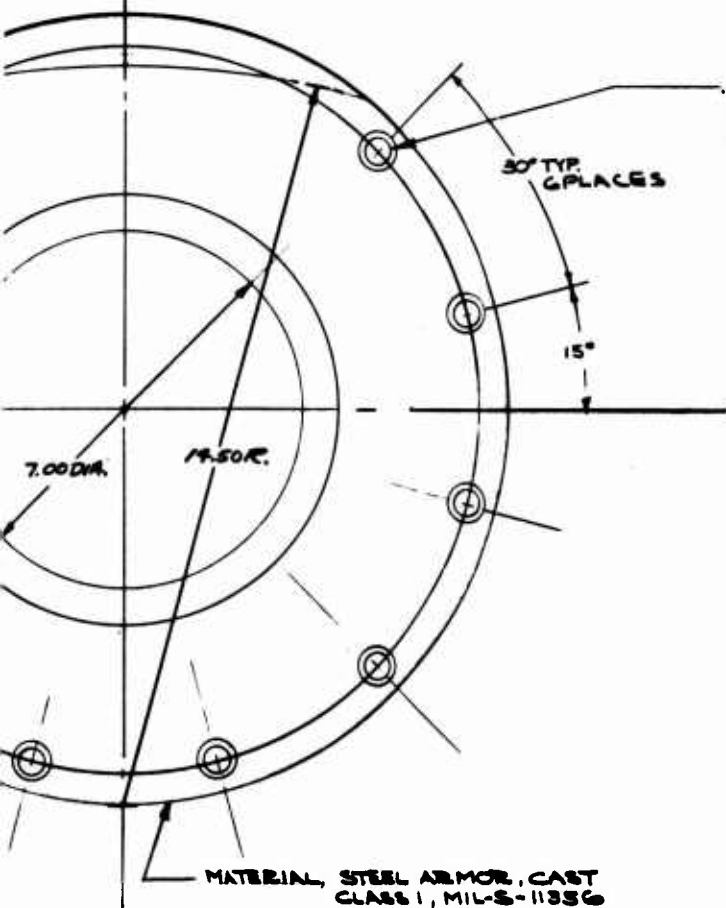
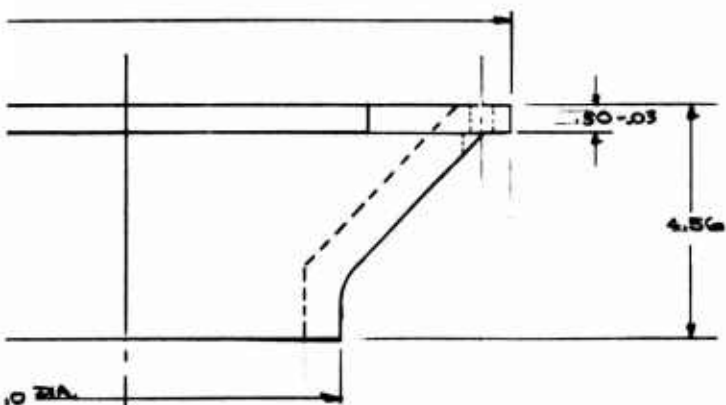

.53 DIA. 53 DIA. S'FACE
 HOLE'S. ON A 14.575 DIA. B.C.
 SCREW-MS16997-141(B)
 THROUGH TO GOFT/LB

30° TYP.
 G PLACES

15°

7.00 DIA.

14.50 DIA.

MATERIAL, STEEL ARMOR, CAST
 CLASS 1, MIL-S-11356

2

SHIELD, GUN FOR 76MM GUN IN XM851 SHIELD			
MAR 25, 1967		REFERENCE	
DRAFTSMAN SUNDBER	CHECKER G.S.	APPROVED M	
SCALE -	SKETCH NUMBER RIA137167	SHEET OF THREE	
FOOT INLAND AIRMAIL			

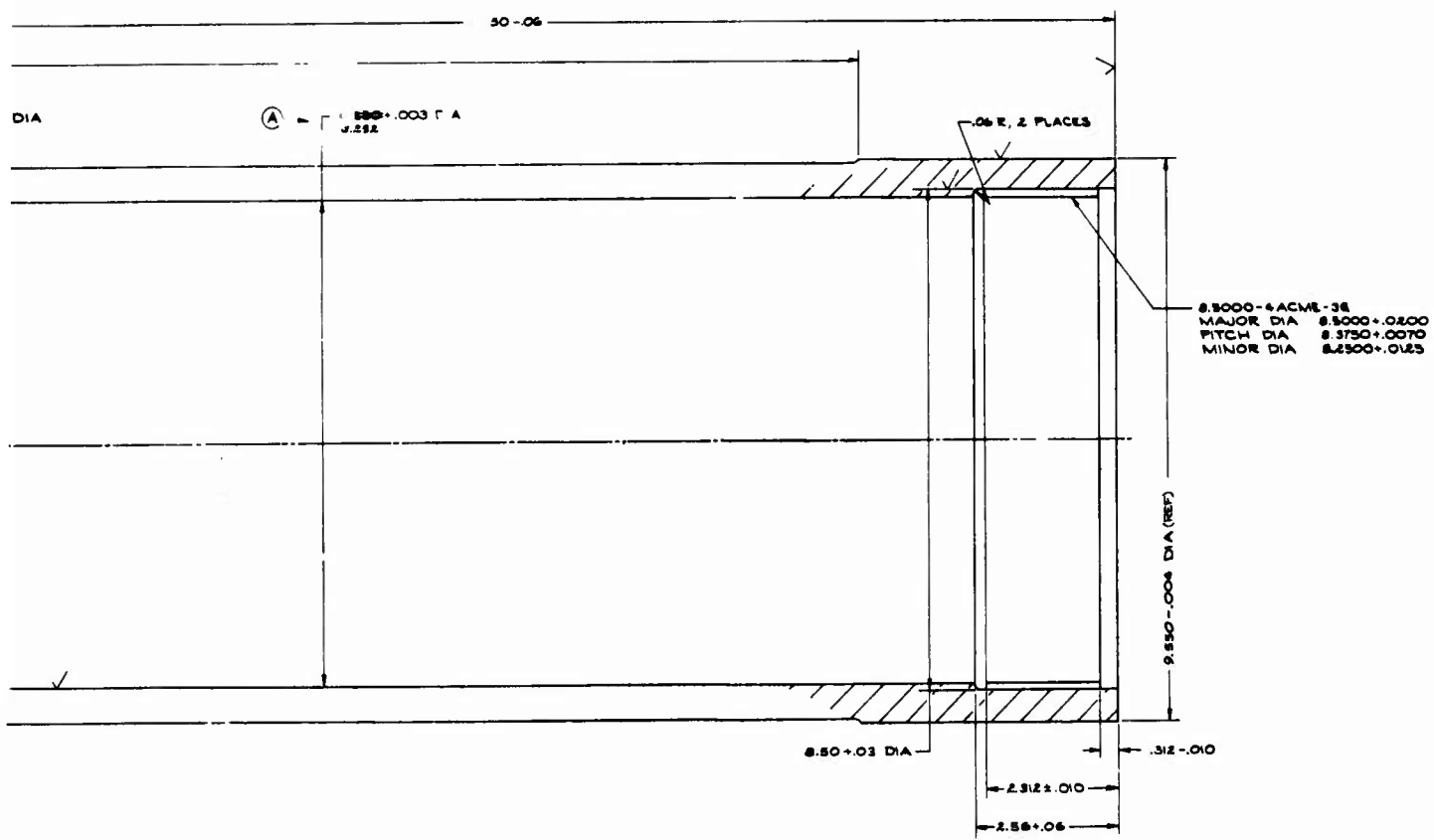

PART NUMBER		NEW PART NUMBER		QUANTITY		DATE	
MATERIAL		FINISH		TOLERANCES		DRAWN BY	
SPECIFICATION		TREATMENT		INSPECTED BY		DATE	
APPROVED BY		DATE		DRAWN BY		DATE	
CHECKED BY		DATE		INSPECTED BY		DATE	
REVISIONS		REVISIONS		REVISIONS		REVISIONS	
1		2		3		4	
5		6		7		8	
9		10		11		12	
13		14		15		16	
17		18		19		20	
21		22		23		24	
25		26		27		28	
29		30		31		32	
33		34		35		36	
37		38		39		40	
41		42		43		44	
45		46		47		48	
49		50		51		52	
53		54		55		56	
57		58		59		60	
61		62		63		64	
65		66		67		68	
69		70		71		72	
73		74		75		76	
77		78		79		80	
81		82		83		84	
85		86		87		88	
89		90		91		92	
93		94		95		96	
97		98		99		100	
101		102		103		104	
105		106		107		108	
109		110		111		112	
113		114		115		116	
117		118		119		120	
121		122		123		124	
125		126		127		128	
129		130		131		132	
133		134		135		136	
137		138		139		140	
141		142		143		144	
145		146		147		148	
149		150		151		152	
153		154		155		156	
157		158		159		160	
161		162		163		164	
165		166		167		168	
169		170		171		172	
173		174		175		176	
177		178		179		180	
181		182		183		184	
185		186		187		188	
189		190		191		192	
193		194		195		196	
197		198		199		200	
201		202		203		204	
205		206		207		208	
209		210		211		212	
213		214		215		216	
217		218		219		220	
221		222		223		224	
225		226		227		228	
229		230		231		232	
233		234		235		236	
237		238		239		240	
241		242		243		244	
245		246		247		248	
249		250		251		252	
253		254		255		256	
257		258		259		260	
261		262		263		264	
265		266		267		268	
269		270		271		272	
273		274		275		276	
277		278		279		280	
281		282		283		284	
285		286		287		288	
289		290		291		292	
293		294		295		296	
297		298		299		300	
301		302		303		304	
305		306		307		308	
309		310		311		312	
313		314		315		316	
317		318		319		320	
321		322		323		324	
325		326		327		328	
329		330		331		332	
333		334		335		336	
337		338		339		340	
341		342		343		344	
345		346		347		348	
349		350		351		352	
353		354		355		356	
357		358		359		360	
361		362		363		364	
365		366		367		368	
369		370		371		372	
373		374		375		376	
377		378		379		380	
381		382		383		384	
385		386		387		388	
389		390		391		392	
393		394		395		396	
397		398		399		400	
401		402		403		404	
405		406		407		408	
409		410		411		412	
413		414		415		416	
417		418		419		420	
421		422		423		424	
425		426		427		428	
429		430		431		432	
433		434		435		436	
437		438		439		440	
441		442		443		444	
445		446		447		448	
449		450		451		452	
453		454		455		456	
457		458		459		460	
461		462		463		464	
465		466		467		468	
469		470		471		472	
473		474		475		476	
477		478		479		480	
481		482		483		484	
485		486		487		488	
489		490		491		492	
493		494		495		496	
497		498		499		500	
501		502		503		504	
505		506		507		508	
509		510		511		512	
513		514		515		516	
517		518		519		520	
521		522		523		524	
525		526		527		528	
529		530		531		532	
533		534		535		536	
537		538		539		540	
541		542		543		544	
545		546		547		548	
549		550		551		552	
553		554		555		556	
557		558		559		560	
561		562		563		564	
565		566		567		568	
569		570		571		572	
573		574		575		576	
577		578		579		580	
581		582		583		584	
585		586		587		588	
589		590		591		592	
593		594		595		596	
597		598		599		600	
601		602		603		604	
605		606		607		608	
609		610		611		612	
613		614		615		616	
617		618		619		620	
621		622		623		624	
625		626		627		628	
629		630		631		632	
633		634		635		636	
637		638		639		640	
641		642		643		644	
645		646		647		648	
649		650		651		652	
653		654		655		656	
657		658		659		660	
661		662		663		664	
665		666		667		668	
669		670		671		672	
673		674		675		676	
677		678		679		680	
681		682		683		684	
685		686		687		688	
689		690		691		692	
693		694		695		696	
697		698		699		700	
701		702		703		704	
705		706		707		708	
709		710		711		712	
713		714		715		716	
717		718		719		720	
721		722		723		724	
725		726		727		728	
729		730		731		732	
733		734		735		736	
737		738		739		740	
741		742		743		744	
745		746		747		748	
749		750		751		752	
753		754		755		756	
757		758		759		760	
761		762		763		764	
765		766		767		768	
769		770		771		772	
773		774		775		776	
777		778		779		780	
781		782		783		784	
785		786		787		788	
789		790		791		792	
793		794		795		796	
797		798		799		800	
801		802		803		804	
805		806		807		808	
809		810		811		812	
813		814		815		816	
817		818		819		820	
821		822		823		824	
825		826		827		828	
829		830		831		832	
833		834		835		836	
837		838		839		840	
841		842		843		844	
845		846		847		848	
849		850		851		852	
853		854		855		856	
857		858		859		860	
861		862		863			

REVISIONS				
MP	SYMBOL	DESCRIPTION	DATE	APPROVAL
	A	ADDED	8-8-67	
	B	DISC HOLED	8-23-67	

.G56

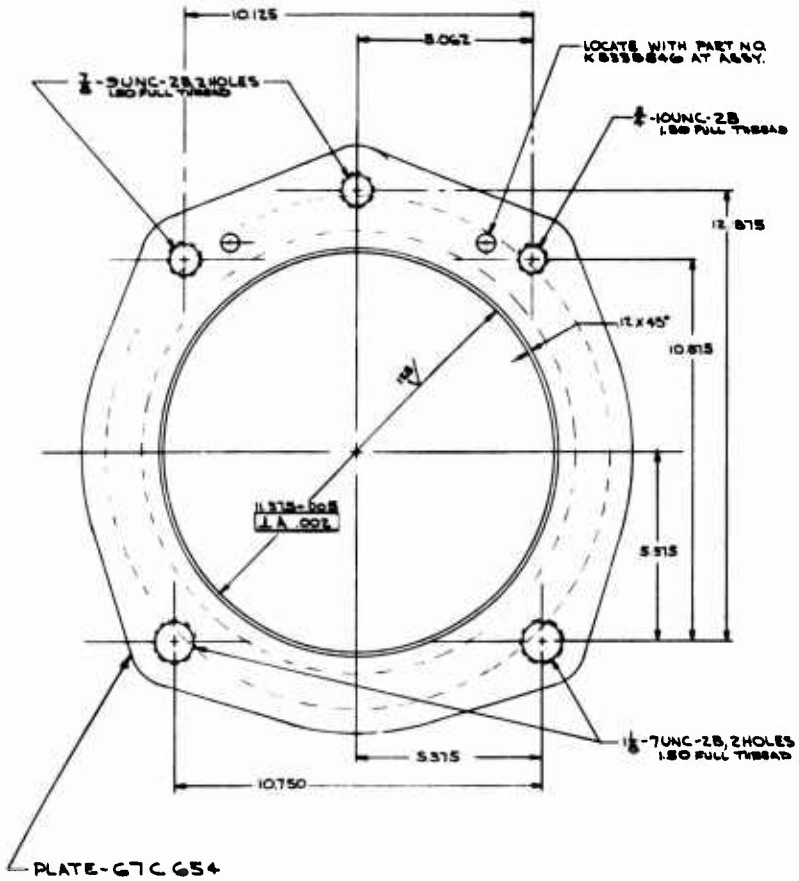
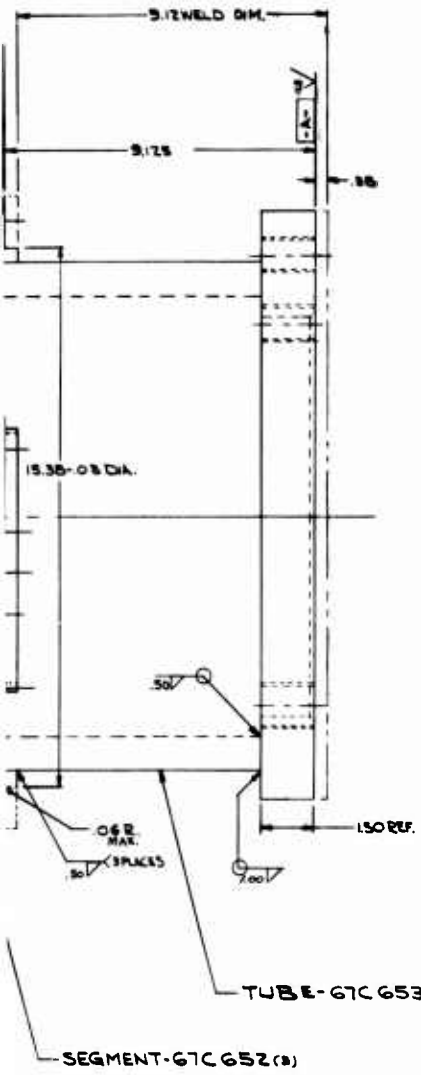

E
D
C
B
G1F655
TECHNICAL ROOM
W/R/W

MECHANICAL PROPERTIES		UNLESS OTHERWISE SPECIFIED DIMENSIONS ARE IN INCHES		ORIGINAL DATE OF DRAWING MAR 8, 1967		PART NO. 67F655		ROCK ISLAND ARSENAL, ROCK ISLAND, ILLINOIS U.S. ARMY WEAPONS COMMAND	
YP		TOLERANCES ON .XX ± .01		DRFTSMAN	CHECKER	1- ADAPTER ASSY			
TS		ANGLES ± 0°30' .XXX ± 005		SCHUBER	CHECKER				
EL 2	G1F736	76MM	MATERIAL	TRACER	CHECKER	CODE IDENT NO. 67F655			
RA	SEE DIMENSIONS		HEAT TREATMENT	ENGINEER	ENGINEER				
BH	NEXT ASSY USED ON		FINAL PROTECTIVE FINISH	SUBMITTED		SCALE 1/2" = 1"			
RH	APPLICATION		NB: 5.8.2.3.0	APPROVED					
DO		AS SPECIFIED	MIL-STD-171	APPROVED		UNIT WT SHEET OF			

2

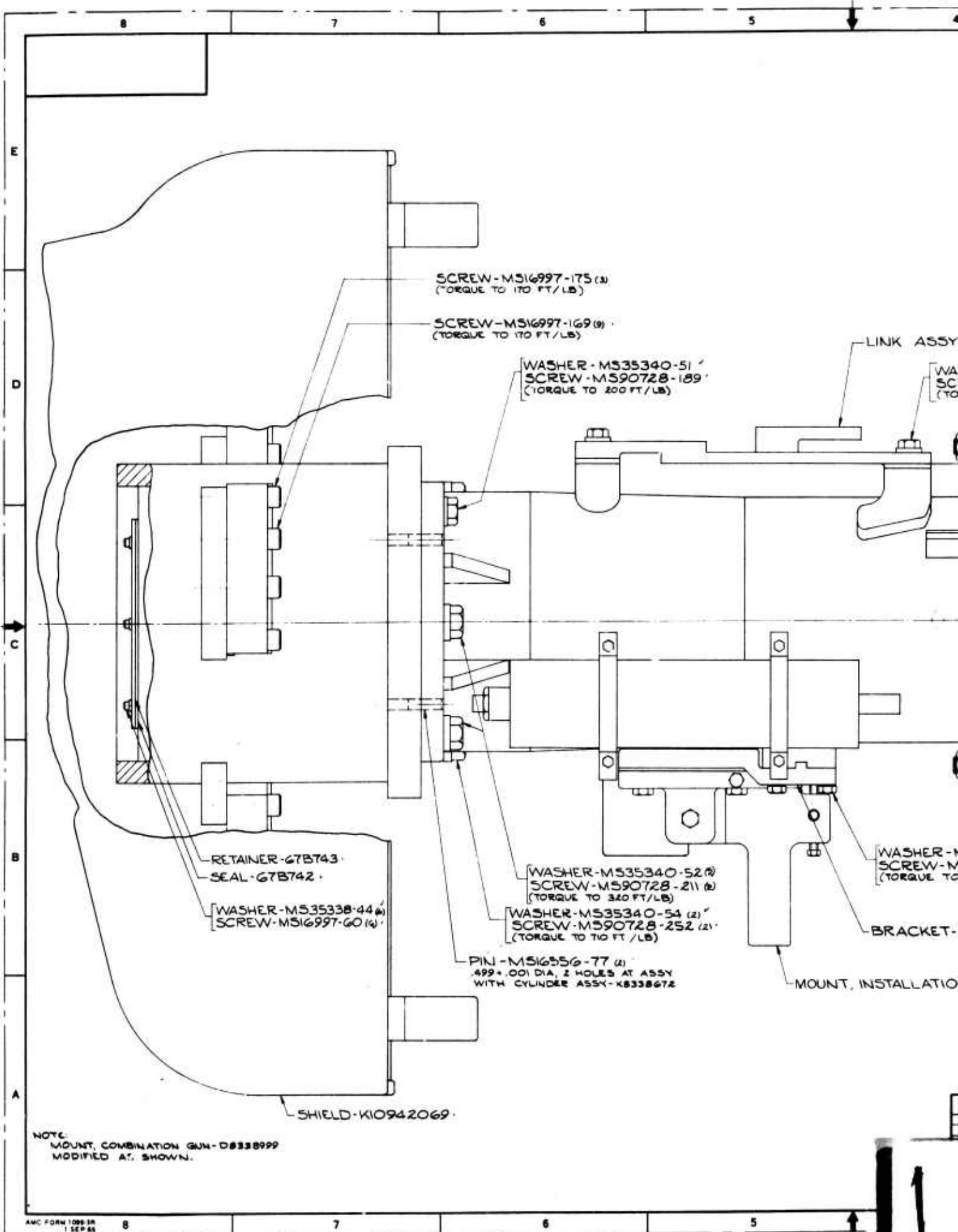

REVISIONS				
NO	SYMBOLS	DESCRIPTION	DATE	APPROVAL

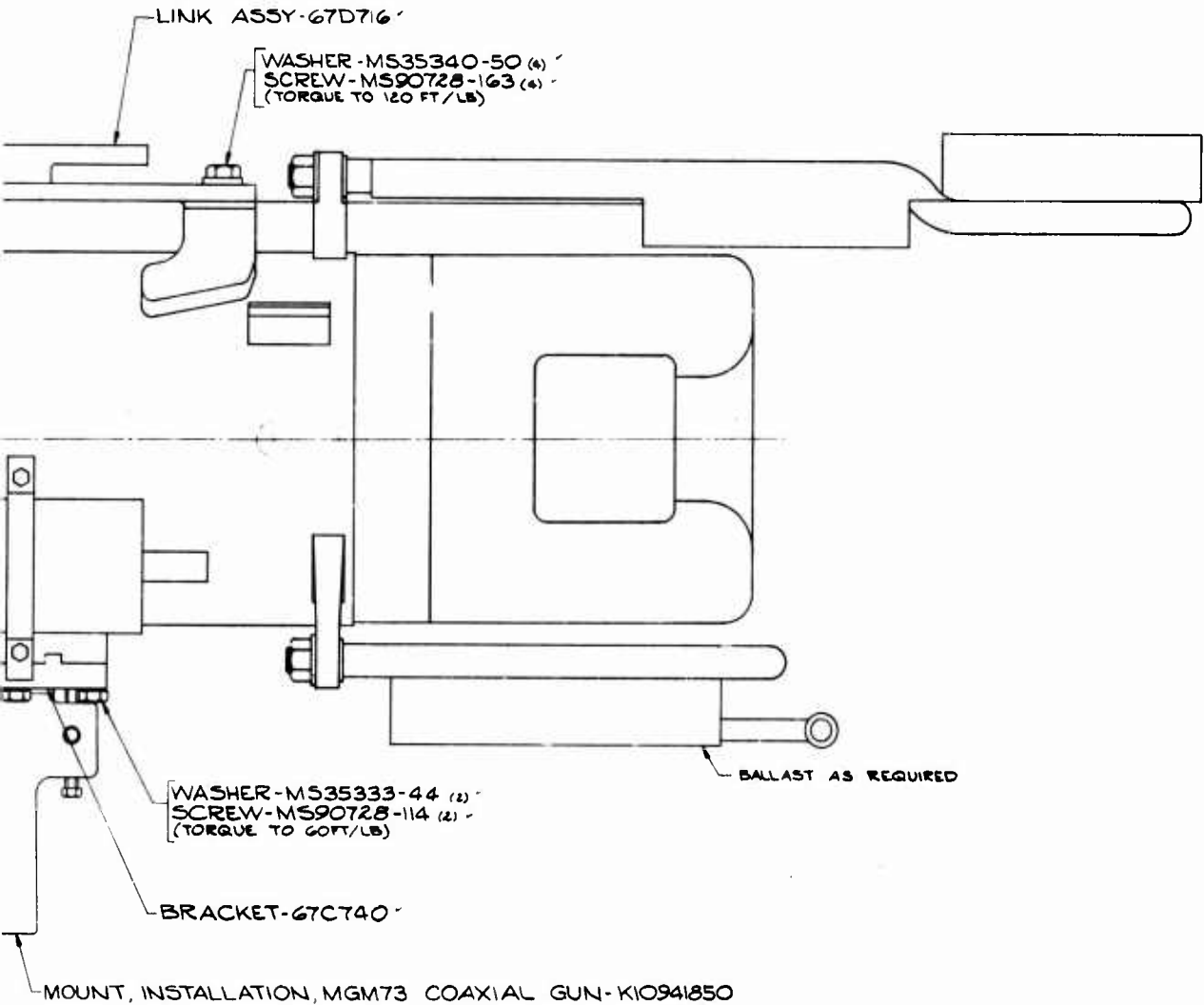

E
D
C
B
A
67F738

PART NO. 67F738

MECHANICAL PROPERTIES		UNLESS OTHERWISE SPECIFIED DIMENSIONS ARE IN INCHES		ORIGINAL DATE OF DRAWING MAR 23, 1967		ROCK ISLAND ARSENAL ROCK ISLAND, ILLINOIS U.S. ARMY WEAPONS COMMAND	
YP		TOLERANCES ON	.XX ±	DRAFTSMAN	CHECKER	GUN, COMBINATION MOUNT	
TS		ANGLES	± .XXX ±	TRACER	CHECKER		
EL 2		76 MM		ENGINEER	ENGINEER	CODE IDENT NO. <input checked="" type="checkbox"/> 67F738	
RA	SEE ENGINEERING RECORDS	MATERIAL		SUBMITTED			
BH	NEXT ASSY USED ON	HEAT TREATMENT		APPROVED		SCALE 1/2	
RH	APPLICATION	FINAL PROTECTIVE FINISH		1 KIT WT		SHEET OF	
DO	APPLY PART NO. AD-5284P00						

12

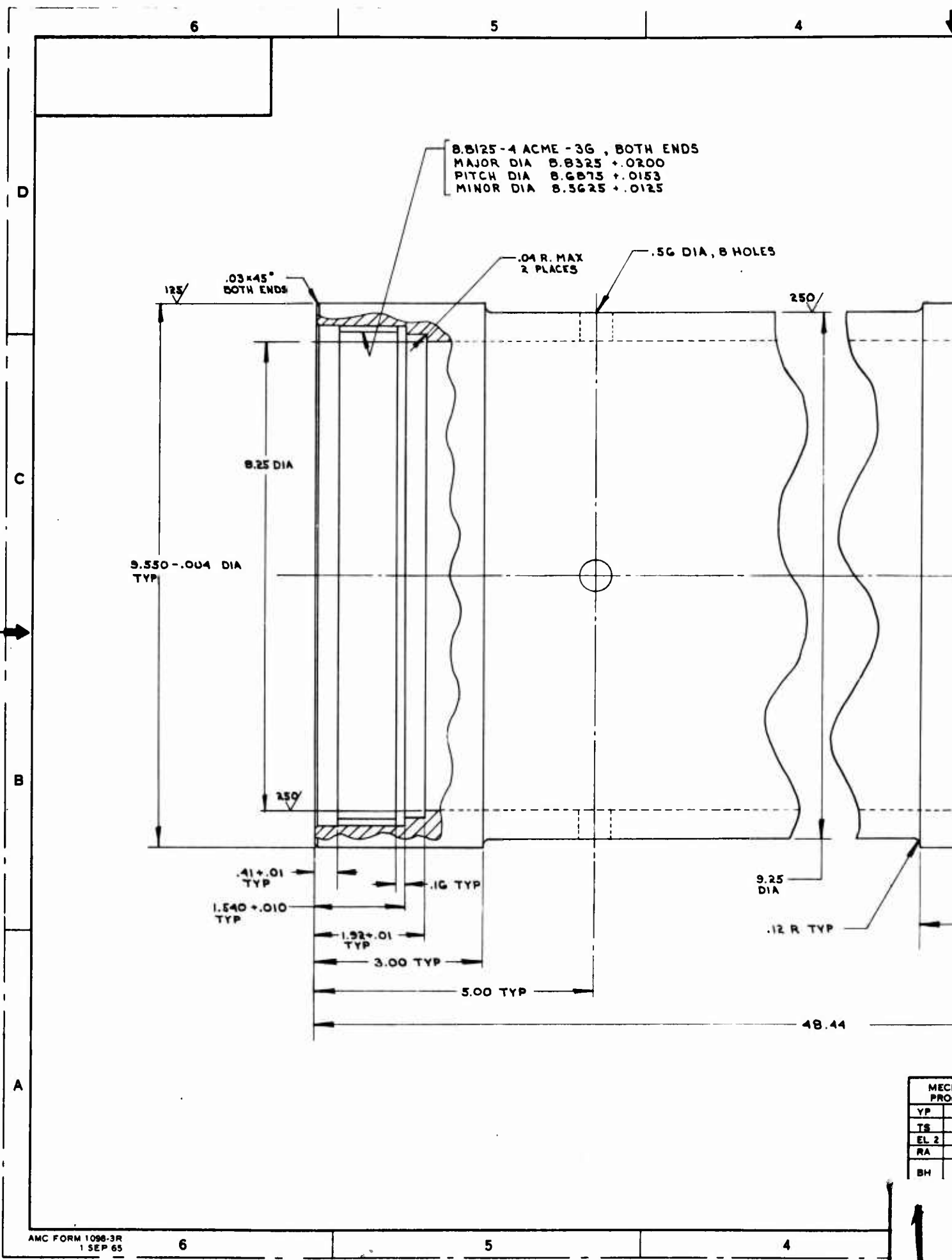



3

2

1

REVISIONS				
NO	SYMBOL	DESCRIPTION	DATE	APPROVAL

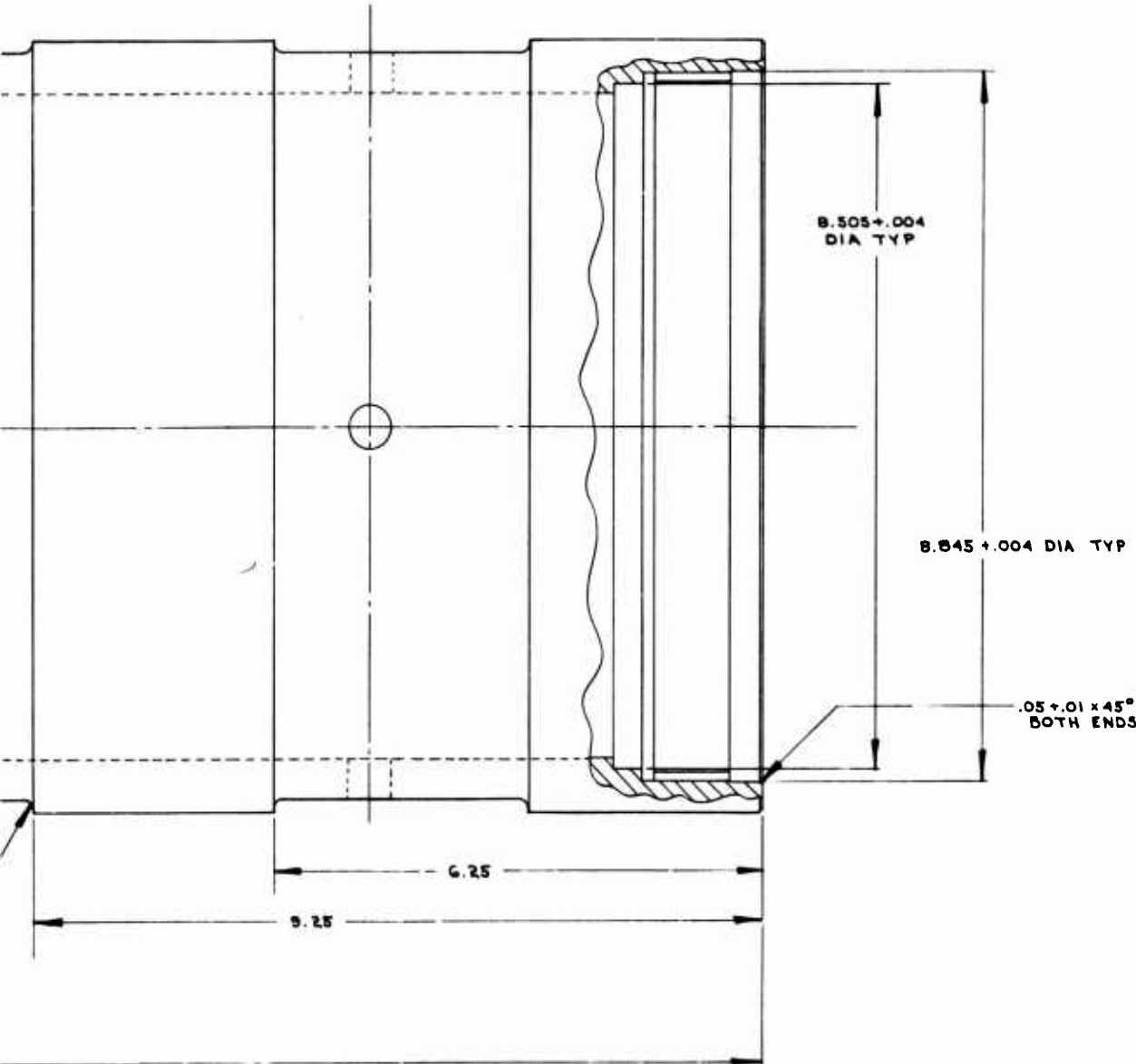

D

C

B

12

67D768

A

XM180 ADAPTER

PART NO. 67D768

ROCK ISLAND ARSENAL, ROCK ISLAND, ILLINOIS
U.S. ARMY WEAPONS COMMAND

1- ADAPTER

CODE IDENT NO. DIMS SIZE
67D768

SCALE 1/1 UNIT WT SHEET OF

MECHANICAL PROPERTIES		UNLESS OTHERWISE SPECIFIED DIMENSIONS ARE IN INCHES	ORIGINAL DATE OF DRAWING
YP			MARCH 14, 1967
TS		TOLERANCES ON .XX ± .02	DRAFTSMAN
EL 2		ANGLES ± 2° .XXX ± —	CHECKER
RA	SEE ENGINEERING RECORDS	MATERIAL STEEL 4130	TRACER
BH	NEXT ASSY USED ON	QA-T-825	ENGINEER
RH	APPLICATION	HEAT TREATMENT	ENGINEER
	DO-NONE APPLY PART NO	FINAL PROTECTIVE FINISH	SUBMITTED
	DO	NO. 3.3.1 OF MIL-STD-171	APPROVED

3

2

1



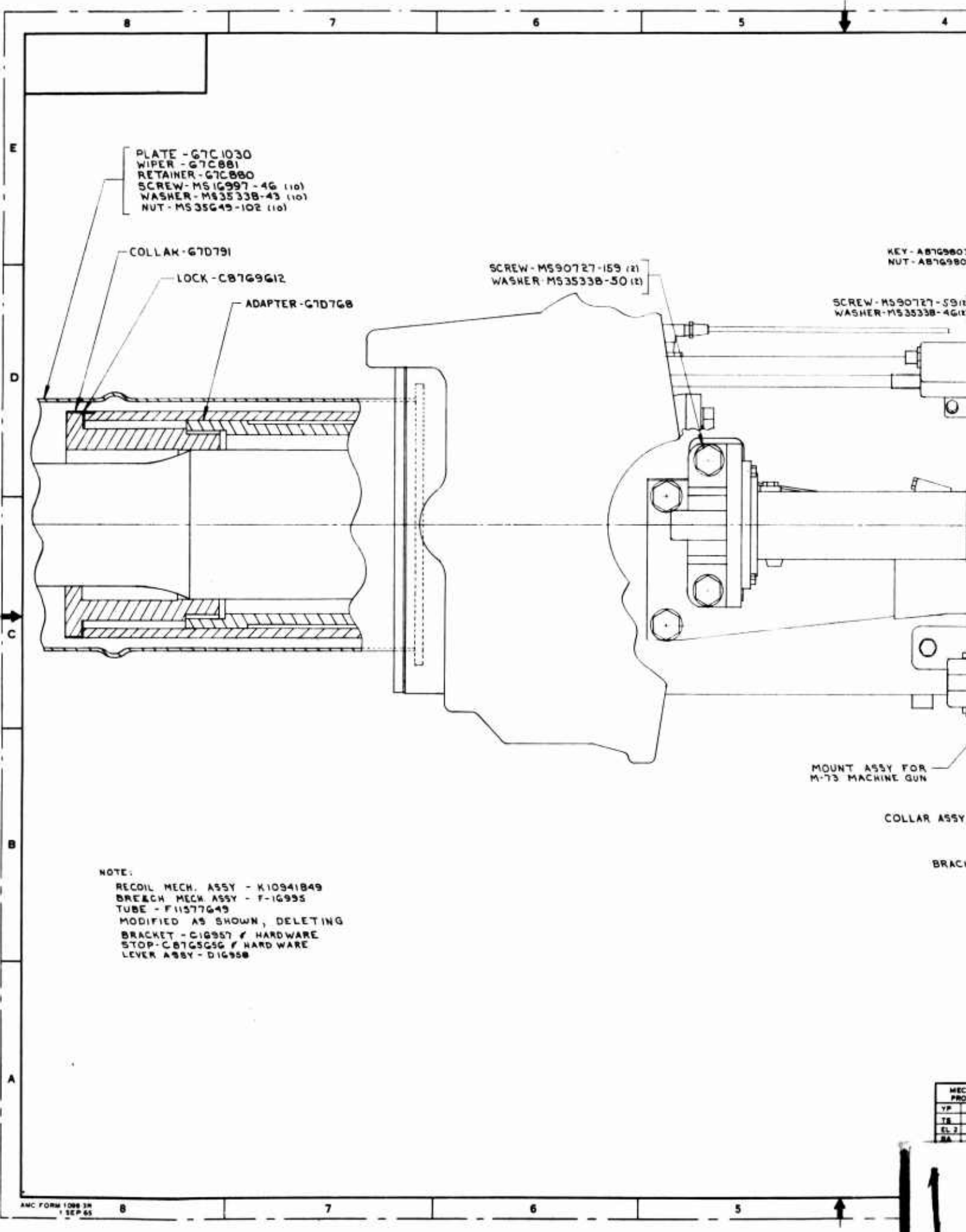

PLATE - G7C1030
 WIPER - G7C881
 RETAINER - G7C880
 SCREW - MS1G997 - 4G (10)
 WASHER - MS3533B-43 (10)
 NUT - MS35G45-102 (10)

COLLAR - G7D791
 LOCK - CB7G9G12
 ADAPTER - G7D7G8

SCREW - MS90727-159 (2)
 WASHER MS3533B-50 (2)

KEY - AB7G9803
 NUT - AB7G9804

SCREW - MS90727-59 (1)
 WASHER - MS3533B-46 (1)

MOUNT ASSY FOR M-73 MACHINE GUN

COLLAR ASSY -

BRACK

NOTE:
 RECOIL MECH. ASSY - K10941B49
 BRE&CH MECH. ASSY - F-1G995
 TUBE - F11577G49
 MODIFIED AS SHOWN, DELETING
 BRACKET - C1G957 / HARDWARE
 STOP - CB7G5G5G / HARDWARE
 LEVER ASSY - D1G958

MECH PROP	
YP	
TR	
EL 2	
BA	

4	3	2	1
---	---	---	---

REVISIONS			
MP	SYM	ZONE	
DESCRIPTION	DATE	APPROVAL	

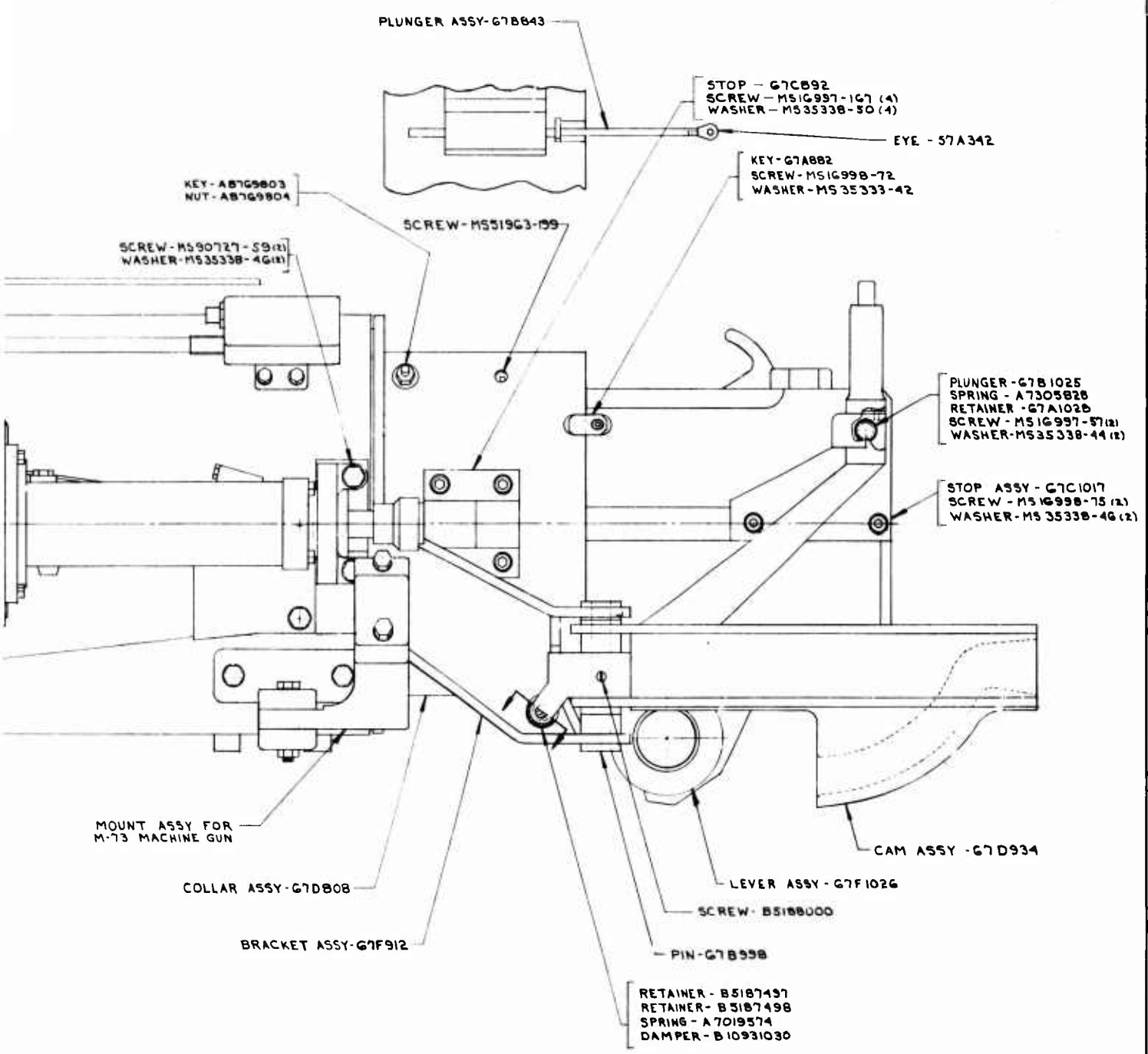

E
D
C
B
A
G7F885
XM180 ADAPTER

MECHANICAL PROPERTIES		UNLESS OTHERWISE SPECIFIED DIMENSIONS ARE IN INCHES		ORIGINAL DATE OF DRAWING MAR 30, 1967		PART NO. G7F885	
YP		TOLERANCES ON	XX ±	DRAFTSMAN	CHECKER	ROCK ISLAND ARSENAL, ROCK ISLAND, ILLINOIS	
TS		ANGLES	XXX ±	TRACER	CHECKER	U.S. ARMY WEAPONS COMMAND	
EL 2	XM180 ADP	MATERIAL		ENGINEER	ENGINEER	XM180 ADAPTER ASSY	
RA	SEE ENGINEERING RECORDS	HEAT TREATMENT		SUBMITTED	APPROVED	CODE IDENT NO	QWG SIZE
BH	NEXT ASSY USED ON	FINAL PROTECTIVE FINISH		[Signature]		G7F885	
RH	APPLICATION			[Signature]		SCALE 1/2	UNIT WT
	APPLY PART NO					SHEET	OF
	DO						

2

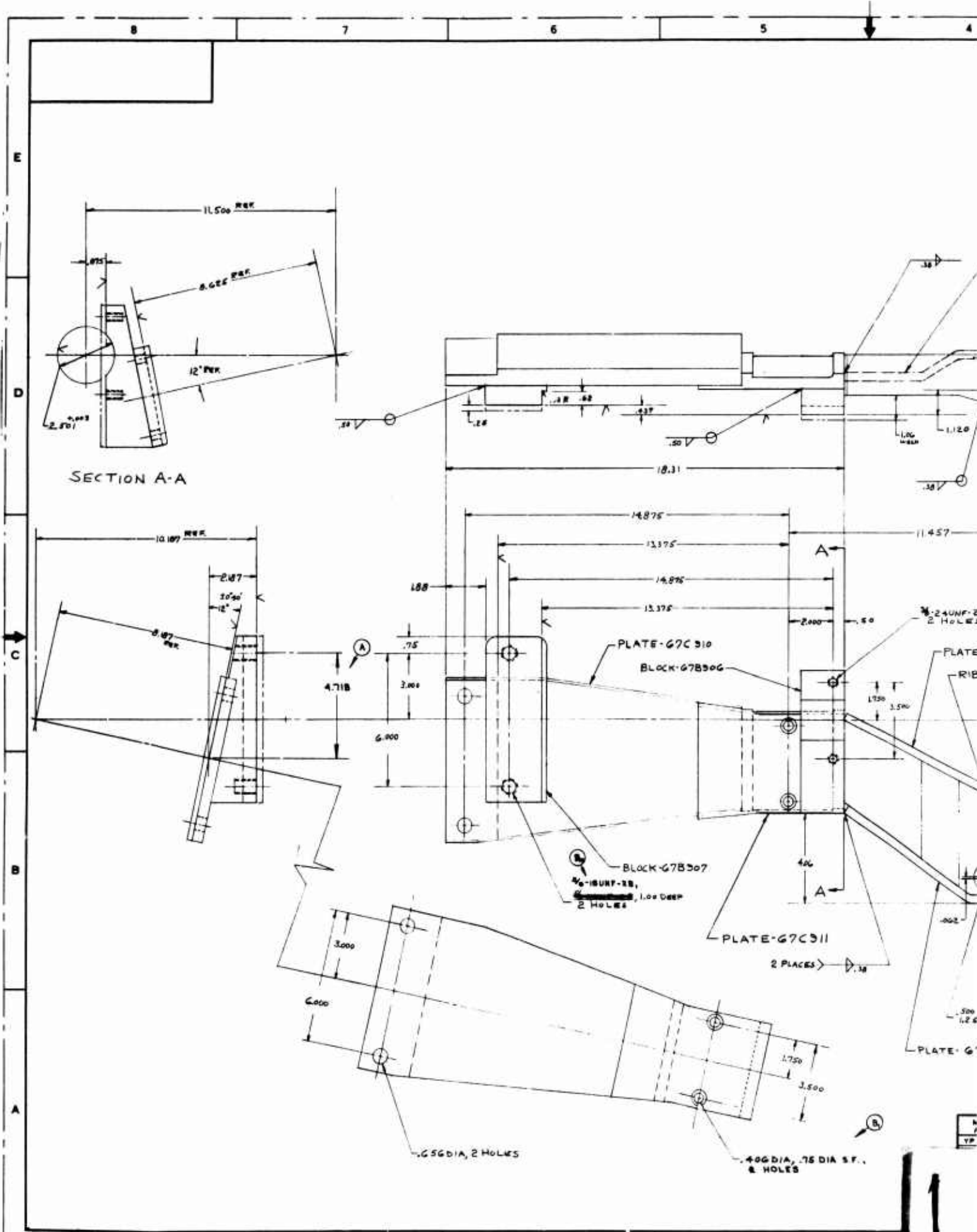

REVISIONS					
MP	SYM	ZONE	DESCRIPTION	DATE	APPROVAL
A*	①	—	⑤ ADDED	3-31-67	<i>[Signature]</i>

3

2

1

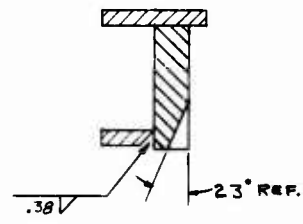
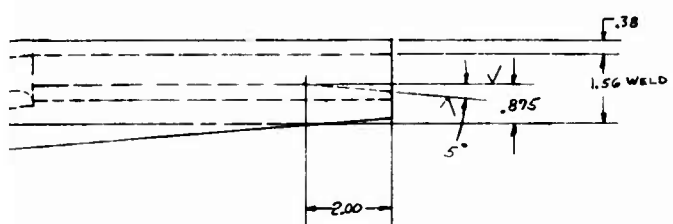

SECTION B-B

C BORE, .38 DEEP
UNF-2B

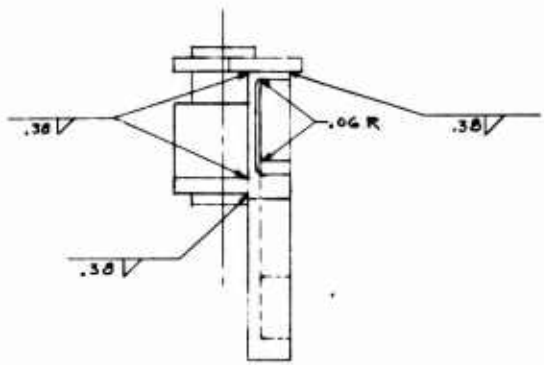
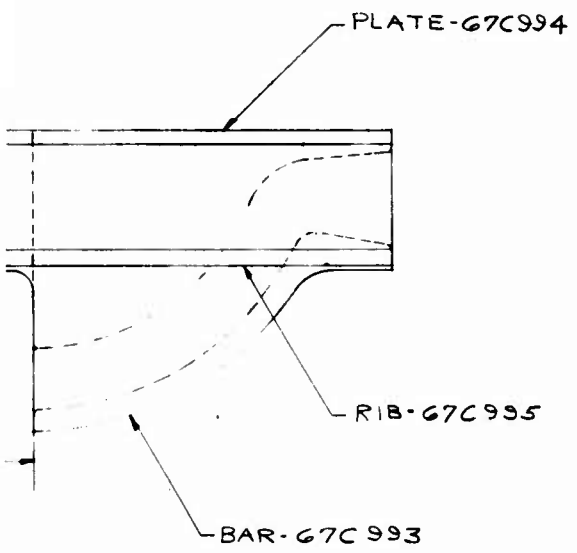

SURFACES MARKED \checkmark TO HAVE \checkmark ¹²⁵

PART NO. 67D934

MECHANICAL PROPERTIES		UNLESS OTHERWISE SPECIFIED DIMENSIONS ARE IN INCHES		ORIGINAL DATE OF DRAWING <u>MAR. 24 1967</u>		ROCK ISLAND ARSENAL, ROCK ISLAND, ILLINOIS U.S. ARMY WEAPONS COMMAND	
YP		TOLERANCES ON .XX ± .02		DRAFTSMAN <u>GEJ</u>	CHECKER	1-CAM ASSY.	
TS		ANGLES ± 1° .XXX ± .025		TRACER	CHECKER		
EL 2	<u>67E885 XM180 ADAPTOR</u>	MATERIAL		ENGINEER <u>GEJ</u>	ENGINEER		
RA		HEAT TREATMENT		SUBMITTED <u>[Signature]</u>		CODE IDENT NO. DWG SIZE	
BH		APPLICATION		APPROVED <u>[Signature]</u>		D <u>67D934</u>	
RH		NEXT ASSY USED ON		FINAL PROTECTIVE FINISH		SCALE <u>1/2</u> UNIT WT SHEET OF	
DO		APPLY PART NO. <u>AS ORDERED</u>		No. 5-3.2.3 OF MIL-STD-171			

D

C

B

67D934

A

XM180 ADAPTOR

2

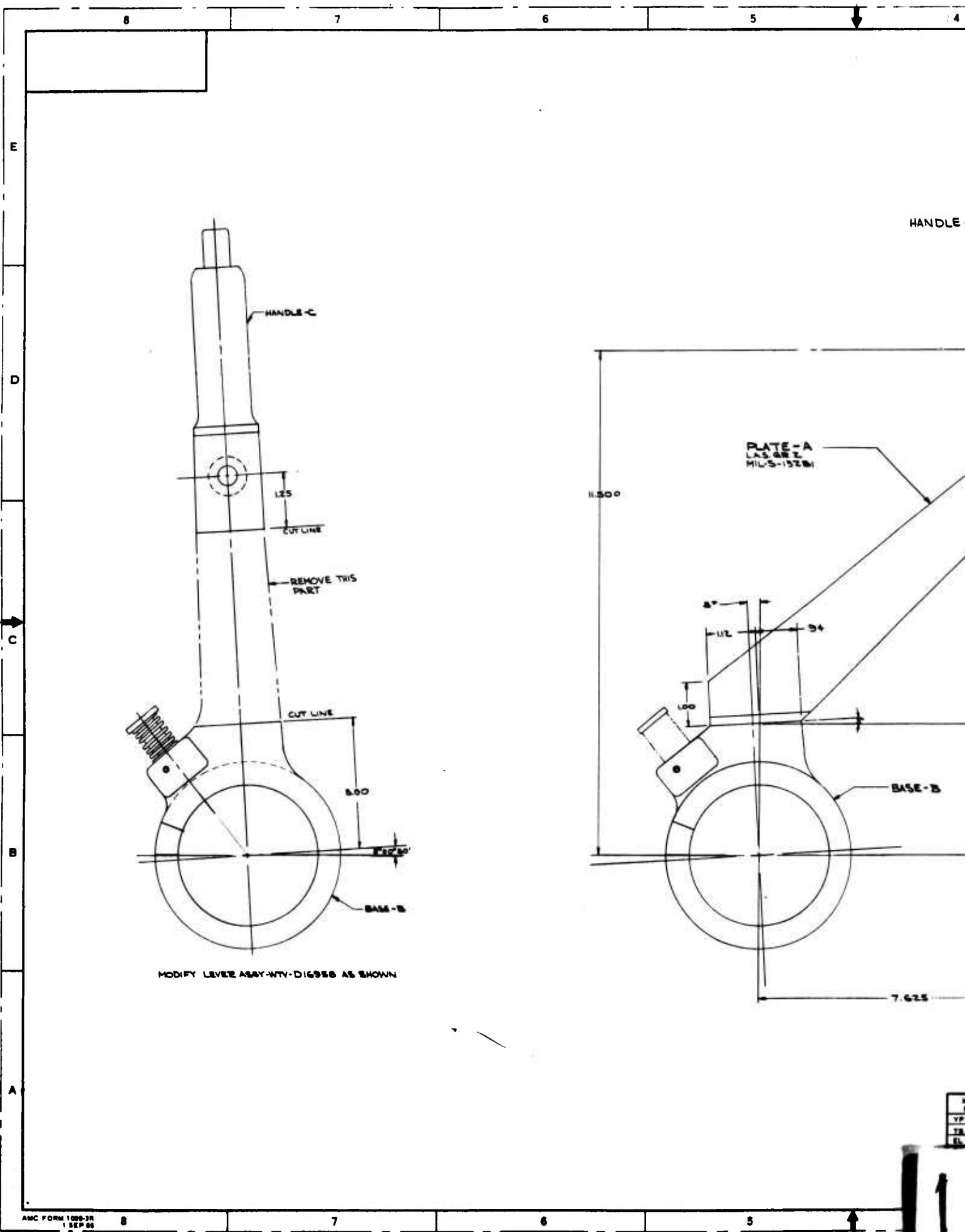

HANDLE - C

PLATE - A
LAS. GR. Z
MIL-S-13201

HANDLE - C

1.25

CUT LINE

REMOVE THIS PART

CUT LINE

8.00

BASE - B

MODIFY LEVEL ASBY-WTV-D16956 AS SHOWN

11.500

8"

1.12

.94

1.00

BASE - B

7.625

E
D
C
B
A

8

7

6

5

4

8

7

6

5

MR
PR
VP
TR
EL 1



5 4 3 2 1

REVISIONS			
MP SYMBOLS	DESCRIPTION	DATE	APPROVAL

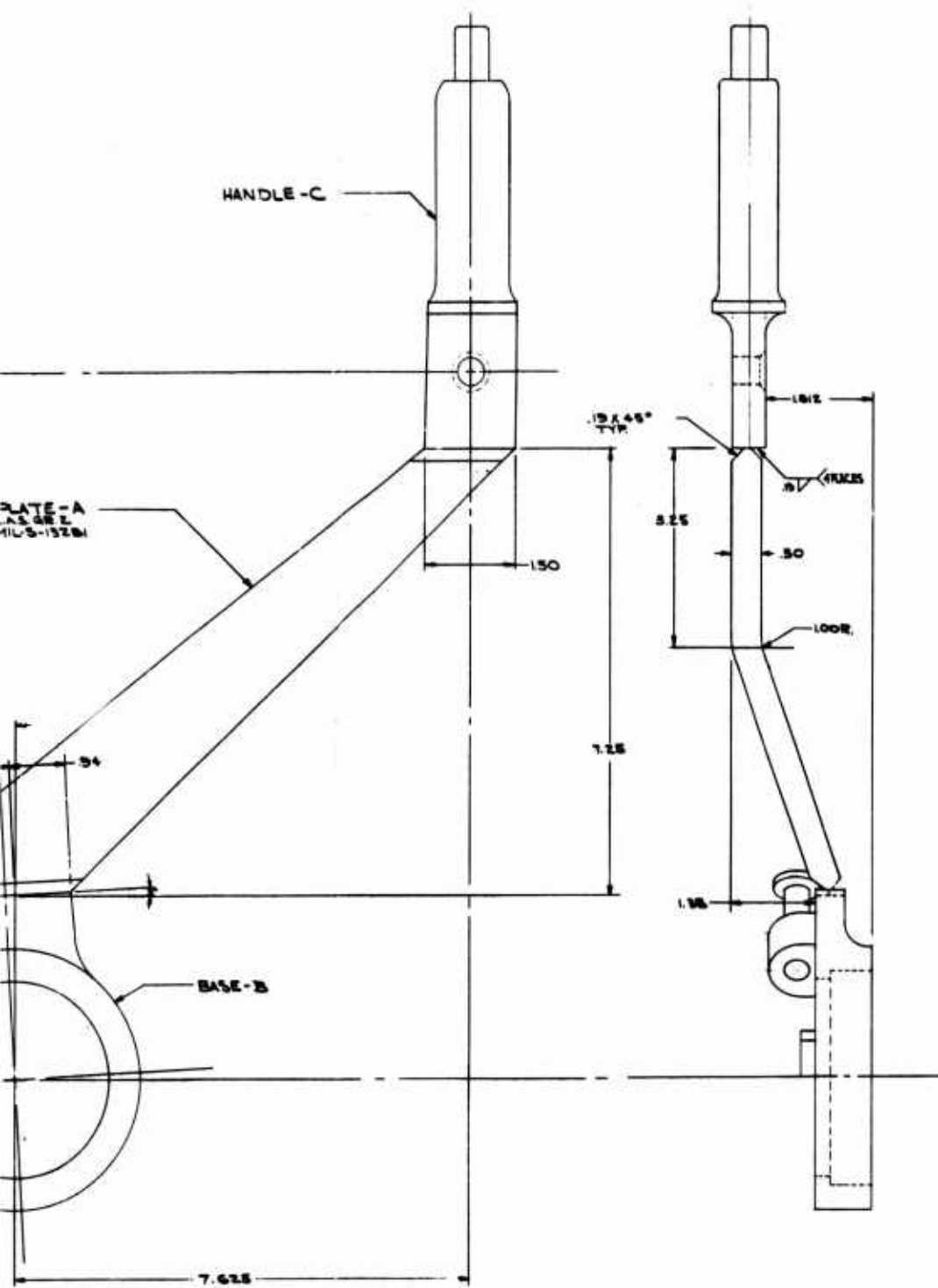

E
D
C
B
A
GIF 1026
MILCO ADAPTER

2

PART NO. 67F1026

MECHANICAL PROPERTIES		UNLESS OTHERWISE SPECIFIED DIMENSIONS ARE IN INCHES		ORIGINAL DATE OF DRAWING MAR 23 1967		ROCK ISLAND ARSENAL ROCK ISLAND, ILLINOIS U.S. ARMY WEAPONS COMMAND	
YP		TOLERANCES ON		DRAWN BY	CHECKED	1-LEVER ASSY	
TR		ANGLES 2		ENGINEER	ENGINEER		
EL 2	67F1026	MATERIAL		APPROVED		CODE IDENT NO. THIS SHEET	
RA		HEAT TREATMENT		67F1026		67F1026	
SH		APPLICATION		SCALE 1/1		UNIT WT	
RN	DO NOT APPLY PART NO	FINAL PROTECTIVE FINISH		SHEET OF			
	OR SPECIFIED	MIL - STD - 171					

5 4 3 2 1

UNCLASSIFIED

Security Classification

DOCUMENT CONTROL DATA - R&D		
<i>(Security classification of title, body of abstract and indexing annotation must be entered when the overall report is classified)</i>		
1. ORIGINATING ACTIVITY (Corporate author) Rock Island Arsenal Rock Island, Illinois 61201		2a. REPORT SECURITY CLASSIFICATION UNCLASSIFIED
		2b. GROUP
3. REPORT TITLE Alternate Armament Combinations for the M551 Vehicle		
4. DESCRIPTIVE NOTES (Type of report and inclusive dates) Final Report Feb 67 - Apr 67		
5. AUTHOR(S) (Last name, first name, initial) Rossmiller, Robert G.		
6. REPORT DATE May 1967	7a. TOTAL NO. OF PAGES 93	7b. NO. OF REFS 1
8a. CONTRACT OR GRANT NO.	8a. ORIGINATOR'S REPORT NUMBER(S) 67-1197	
b. PROJECT NO. None	9b. OTHER REPORT NO(S) (Any other numbers that may be assigned this report) None	
c.		
d.		
10. AVAILABILITY/LIMITATION NOTICES Each transmittal of this document outside the Department of Defense must have prior approval of the R&E Division, Rock Island Arsenal.		
11. SUPPLEMENTARY NOTES None	12. SPONSORING MILITARY ACTIVITY None	
13. ABSTRACT <p>This is a final report of the analysis, design, manufacture, and test of alternate armament fired from the M551 Vehicle. Problem areas are discussed and solutions noted. Four systems were fired. One each of 76mm and 105mm with a hand operated breech, and one each of 76mm and 105mm with a semi-automatic breech. The recoil mechanisms used were the M76 and the one used with the M81E12 Cannon in the M551 Vehicle. All firings were instrumented and a summation of test results are tabulated. Any one of these systems could be optimized to be used in the M551 Vehicle.</p>		

DD FORM 1473
1 JAN 64

UNCLASSIFIED

Security Classification

14. KEY WORDS	LINK A		LINK B		LINK C	
	ROLE	WT	ROLE	WT	ROLE	WT
Combat Vehicle Primary Armament Recoil Mechanisms Mount Test Firings Manual and Semi-Automatic Breech Breech Operating Cam Coaxial Mount						

INSTRUCTIONS

1. **ORIGINATING ACTIVITY:** Enter the name and address of the contractor, subcontractor, grantee, Department of Defense activity or other organization (*corporate author*) issuing the report.
- 2a. **REPORT SECURITY CLASSIFICATION:** Enter the overall security classification of the report. Indicate whether "Restricted Data" is included. Marking is to be in accordance with appropriate security regulations.
- 2b. **GROUP:** Automatic downgrading is specified in DoD Directive 5200.10 and Armed Forces Industrial Manual. Enter the group number. Also, when applicable, show that optional markings have been used for Group 3 and Group 4 as authorized.
3. **REPORT TITLE:** Enter the complete report title in all capital letters. Titles in all cases should be unclassified. If a meaningful title cannot be selected without classification, show title classification in all capitals in parenthesis immediately following the title.
4. **DESCRIPTIVE NOTES:** If appropriate, enter the type of report, e.g., interim, progress, summary, annual, or final. Give the inclusive dates when a specific reporting period is covered.
5. **AUTHOR(S):** Enter the name(s) of author(s) as shown on or in the report. Enter last name, first name, middle initial. If military, show rank and branch of service. The name of the principal author is an absolute minimum requirement.
6. **REPORT DATE:** Enter the date of the report as day, month, year, or month, year. If more than one date appears on the report, use date of publication.
- 7a. **TOTAL NUMBER OF PAGES:** The total page count should follow normal pagination procedures, i.e., enter the number of pages containing information.
- 7b. **NUMBER OF REFERENCES:** Enter the total number of references cited in the report.
- 8a. **CONTRACT OR GRANT NUMBER:** If appropriate, enter the applicable number of the contract or grant under which the report was written.
- 8b, 8c, & 8d. **PROJECT NUMBER:** Enter the appropriate military department identification, such as project number, subproject number, system numbers, task number, etc.
- 9a. **ORIGINATOR'S REPORT NUMBER(S):** Enter the official report number by which the document will be identified and controlled by the originating activity. This number must be unique to this report.
- 9c. **OTHER REPORT NUMBER(S):** If the report has been assigned any other report numbers (*either by the originator or by the sponsor*), also enter this number(s).

10. **AVAILABILITY/LIMITATION NOTICES:** Enter any limitations on further dissemination of the report, other than those imposed by security classification, using standard statements such as:
 - (1) "Qualified requesters may obtain copies of this report from DDC."
 - (2) "Foreign announcement and dissemination of this report by DDC is not authorized."
 - (3) "U. S. Government agencies may obtain copies of this report directly from DDC. Other qualified DDC users shall request through _____."
 - (4) "U. S. military agencies may obtain copies of this report directly from DDC. Other qualified users shall request through _____."
 - (5) "All distribution of this report is controlled. Qualified DDC users shall request through _____."

If the report has been furnished to the Office of Technical Services, Department of Commerce, for sale to the public, indicate this fact and enter the price, if known.
11. **SUPPLEMENTARY NOTES:** Use for additional explanatory notes.
12. **SPONSORING MILITARY ACTIVITY:** Enter the name of the departmental project office or laboratory sponsoring (*paying for*) the research and development. Include address.
13. **ABSTRACT:** Enter an abstract giving a brief and factual summary of the document indicative of the report, even though it may also appear elsewhere in the body of the technical report. If additional space is required, a continuation sheet shall be attached.

It is highly desirable that the abstract of classified reports be unclassified. Each paragraph of the abstract shall end with an indication of the military security classification of the information in the paragraph, represented as (TS), (S), (C), or (U).

There is no limitation on the length of the abstract. However, the suggested length is from 150 to 225 words.
14. **KEY WORDS:** Key words are technically meaningful terms or short phrases that characterize a report and may be used as index entries for cataloging the report. Key words must be selected so that no security classification is required. Identifiers, such as equipment model designation, trade name, military project code name, geographic location, may be used as key words but will be followed by an indication of technical context. The assignment of links, rules, and weights is optional.

AD Accession No.
Research & Engineering Division, Rock Island Arsenal,
Rock Island, Illinois 61201
ALTERNATE ARMAMENT COMBINATIONS FOR THE M551 VEHICLE
by Robert G. Rossmiller

RIA R&E Report 67-1197, May 1967
93 P. Incl. Drawings & Figures
Unclassified Report

This is a final report of the analysis, design, manu-
facture, and test of alternate armament fired from the
M551 Vehicle. Problem areas are discussed and solutions
noted. Four systems were fired. One each of 76mm and
105mm with a hand operated breech, and one each of 76mm
and 105mm with a semi-automatic breech. The recoil
mechanisms used were the M76 and the one used with the
M81E12 Cannon in the M551 Vehicle. All firings were
instrumented and a summation of test results are tabu-
lated. Any one of these systems could be optimized
to be used in the M551 Vehicle.

UNCLASSIFIED

1. Tank Guns
2. Recoil Mechanisms
3. Combat Vehicle

- I. Robert Rossmiller
- II. Rock Island Arsenal
- III. Development Engineering Branch

DISTRIBUTION

Copies obtainable from
Defense Documentation
Center

UNCLASSIFIED

UNCLASSIFIED

1. Tank Guns
2. Recoil Mechanisms
3. Combat Vehicle

- I. Robert Rossmiller
- II. Rock Island Arsenal
- III. Development Engineering Branch

DISTRIBUTION

Copies obtainable from
Defense Documentation
Center

UNCLASSIFIED

AD Accession No.
Research & Engineering Division, Rock Island Arsenal,
Rock Island, Illinois 61201
ALTERNATE ARMAMENT COMBINATIONS FOR THE M551 VEHICLE
by Robert G. Rossmiller

RIA R&E Report 67-1197, May 1967
93 P. Incl. Drawings & Figures
Unclassified Report

This is a final report of the analysis, design, manu-
facture, and test of alternate armament fired from the
M551 Vehicle. Problem areas are discussed and solutions
noted. Four systems were fired. One each of 76mm and
105mm with a hand operated breech, and one each of 76mm
and 105mm with a semi-automatic breech. The recoil
mechanisms used were the M76 and the one used with the
M81E12 Cannon in the M551 Vehicle. All firings were
instrumented and a summation of test results are tabu-
lated. Any one of these systems could be optimized
to be used in the M551 Vehicle.

UNCLASSIFIED

1. Tank Guns
2. Recoil Mechanisms
3. Combat Vehicle

- I. Robert Rossmiller
- II. Rock Island Arsenal
- III. Development Engineering Branch

DISTRIBUTION

Copies obtainable from
Defense Documentation
Center

UNCLASSIFIED

UNCLASSIFIED

1. Tank Guns
2. Recoil Mechanisms
3. Combat Vehicle

- I. Robert Rossmiller
- II. Rock Island Arsenal
- III. Development Engineering Branch

DISTRIBUTION

Copies obtainable from
Defense Documentation
Center

UNCLASSIFIED

AD Accession No.
Research & Engineering Division, Rock Island Arsenal,
Rock Island, Illinois 61201
ALTERNATE ARMAMENT COMBINATIONS FOR THE M551 VEHICLE
by Robert G. Rossmiller

RIA R&E Report 67-1197, May 1967
93 P. Incl. Drawings & Figures
Unclassified Report

This is a final report of the analysis, design, manu-
facture, and test of alternate armament fired from the
M551 Vehicle. Problem areas are discussed and solutions
noted. Four systems were fired. One each of 76mm and
105mm with a hand operated breech, and one each of 76mm
and 105mm with a semi-automatic breech. The recoil
mechanisms used were the M76 and the one used with the
M81E12 Cannon in the M551 Vehicle. All firings were
instrumented and a summation of test results are tabu-
lated. Any one of these systems could be optimized
to be used in the M551 Vehicle.

AD Accession No.
Research & Engineering Division, Rock Island Arsenal,
Rock Island, Illinois 61201
ALTERNATE ARMAMENT COMBINATIONS FOR THE M551 VEHICLE
by Robert G. Rossmiller

RIA R&E Report 67-1197, May 1967
93 P. Incl. Drawings & Figures
Unclassified Report

This is a final report of the analysis, design, manu-
facture, and test of alternate armament fired from the
M551 Vehicle. Problem areas are discussed and solutions
noted. Four systems were fired. One each of 76mm and
105mm with a hand operated breech, and one each of 76mm
and 105mm with a semi-automatic breech. The recoil
mechanisms used were the M76 and the one used with the
M81E12 Cannon in the M551 Vehicle. All firings were
instrumented and a summation of test results are tabu-
lated. Any one of these systems could be optimized
to be used in the M551 Vehicle.

AD Accession No.
Research & Engineering Division, Rock Island Arsenal,
Rock Island, Illinois 61201
ALTERNATE ARMAMENT COMBINATIONS FOR THE M551 VEHICLE
by Robert G. Rosemiller

RIA R&E Report 67-1197, May 1967
93 p. Incl. Drawings & Figures
Unclassified Report

This is a final report of the analysis, design, manufacture, and test of alternate armament fired from the M551 Vehicle. Problem areas are discussed and solutions noted. Four systems were fired. One each of 76mm and 105mm with a hand operated breech, and one each of 76mm and 105mm with a semi-automatic breech. The recoil mechanisms used were the M76 and the one used with the M9E12 Cannon in the M551 Vehicle. All firings were instrumented and a summation of test results are tabulated. Any one of these systems could be optimized to be used in the M551 Vehicle.

UNCLASSIFIED

1. Tank Guns
2. Recoil Mechanisms
3. Combat Vehicle

- I. Robert Rosemiller
- II. Rock Island Arsenal
- III. Development Engineering Branch

DISTRIBUTION

Copies obtainable from
Defense Documentation
Center

UNCLASSIFIED

AD Accession No.
Research & Engineering Division, Rock Island Arsenal,
Rock Island, Illinois 61201
ALTERNATE ARMAMENT COMBINATIONS FOR THE M551 VEHICLE
by Robert G. Rosemiller

RIA R&E Report 67-1197, May 1967
93 p. Incl. Drawings & Figures
Unclassified report.

This is a final report of the analysis, design, manufacture, and test of alternate armament fired from the M551 Vehicle. Problem areas are discussed and solutions noted. Four systems were fired. One each of 76mm and 105mm with a hand operated breech, and one each of 76mm and 105mm with a semi-automatic breech. The recoil mechanisms used were the M76 and the one used with the M9E12 Cannon in the M551 Vehicle. All firings were instrumented and a summation of test results are tabulated. Any one of these systems could be optimized to be used in the M551 Vehicle.

UNCLASSIFIED

1. Tank Guns
2. Recoil Mechanisms
3. Combat Vehicle

- I. Robert Rosemiller
- II. Rock Island Arsenal
- III. Development Engineering Branch

DISTRIBUTION

Copies obtainable from
Defense Documentation
Center

UNCLASSIFIED

AD Accession No.
Research & Engineering Division, Rock Island Arsenal,
Rock Island, Illinois 61201
ALTERNATE ARMAMENT COMBINATIONS FOR THE M551 VEHICLE
by Robert G. Rosemiller

RIA R&E Report 67-1197, May 1967
93 p. Incl. Drawings & Figures
Unclassified Report

This is a final report of the analysis, design, manufacture, and test of alternate armament fired from the M551 Vehicle. Problem areas are discussed and solutions noted. Four systems were fired. One each of 76mm and 105mm with a hand operated breech, and one each of 76mm and 105mm with a semi-automatic breech. The recoil mechanisms used were the M76 and the one used with the M9E12 Cannon in the M551 Vehicle. All firings were instrumented and a summation of test results are tabulated. Any one of these systems could be optimized to be used in the M551 Vehicle.

UNCLASSIFIED

1. Tank Guns
2. Recoil Mechanisms
3. Combat Vehicle

- I. Robert Rosemiller
- II. Rock Island Arsenal
- III. Development Engineering Branch

DISTRIBUTION

Copies obtainable from
Defense Documentation
Center

UNCLASSIFIED

AD Accession No.
Research & Engineering Division, Rock Island Arsenal,
Rock Island, Illinois 61201
ALTERNATE ARMAMENT COMBINATIONS FOR THE M551 VEHICLE
by Robert G. Rosemiller

RIA R&E Report 67-1197, May 1967
93 p. Incl. Drawings & Figures
Unclassified Report

This is a final report of the analysis, design, manufacture, and test of alternate armament fired from the M551 Vehicle. Problem areas are discussed and solutions noted. Four systems were fired. One each of 76mm and 105mm with a hand operated breech, and one each of 76mm and 105mm with a semi-automatic breech. The recoil mechanisms used were the M76 and the one used with the M9E12 Cannon in the M551 Vehicle. All firings were instrumented and a summation of test results are tabulated. Any one of these systems could be optimized to be used in the M551 Vehicle.

UNCLASSIFIED

1. Tank Guns
2. Recoil Mechanisms
3. Combat Vehicle

- I. Robert Rosemiller
- II. Rock Island Arsenal
- III. Development Engineering Branch

DISTRIBUTION

Copies obtainable from
Defense Documentation
Center

UNCLASSIFIED