

UNCLASSIFIED

| |
|---|
| |
| |
| |
| AD NUMBER |
| AD818780 |
| NEW LIMITATION CHANGE |
| TO Approved for public release, distribution unlimited |
| FROM Distribution authorized to U.S. Gov't. agencies and their contractors; Critical Technology; JUL 1967. Other requests shall be referred to Air Force Materials Lab., Attn: MAAM, Wright-Patterson AFB, OH 45433. |
| AUTHORITY |
| Air Force Materials Lab. ltr dtd 12 Jan 1972 |

THIS PAGE IS UNCLASSIFIED

70

AD NO. — ADBI 8780
DDC FILE COPY

DEVELOPMENT OF ENGINEERING DATA ON TITANIUM EXTRUSION FOR USE IN AEROSPACE DESIGN

R. M. Brockett
J. A. Gottbrath
LOCKHEED-CALIFORNIA COMPANY

TECHNICAL REPORT AFML-TR-67-189

JULY 1967

This document is subject to special export controls and each transmittal to foreign governments or foreign nationals may be made only with prior approval of the Air Force Materials Laboratory (MAAM).



DDC
RECEIVED
AUG 23 1967
D 90

Air Force Materials Laboratory
Directorate of Laboratories
Air Force Systems Command
Wright-Patterson Air Force Base, Ohio

See 1473
in back

NOTICE

When Government drawings, specifications, or other data are used for any purpose other than in connection with a definitely related Government procurement operation, the United States Government thereby incurs no responsibility nor any obligation whatsoever; and the fact that the Government may have formulated, furnished, or in any way supplied the said drawings, specifications, or other data, is not to be regarded by implication or otherwise as in any manner licensing the holder or any other person or corporation, or conveying any rights or permission to manufacture, use, or sell any patented invention that may in any way be related thereto.

DATE: _____

CLASSIFICATION: _____

BY: _____

REPRODUCTION/AVAILABILITY CODES

| GENL. | AVAIL. and/or SPECIAL |
|-------|-----------------------|
| g | |

Copies of this report should not be returned unless return is required by security considerations, contractual obligations, or notice on a specific document.

DEVELOPMENT OF ENGINEERING DATA
ON TITANIUM EXTRUSION FOR USE IN
AEROSPACE DESIGN

R. M. Brockett

J. A. Gottbrath

This document is subject to special export controls and each transmittal to foreign governments or foreign nationals may be made only with prior approval of the Air Force Materials Laboratory (MAAM)

FOREWORD

This report was prepared by the Lockheed-California Company, Burbank, California under USAF Contract No. AF 33(615)-5080, "Development of Engineering Data on Titanium Extrusion for Use In Aerospace Design". The contract was initiated under Project No. 7381, "Materials Applications", Task No. 738106, "Design Information Development". This work was performed under the direction of Lt. Harold Lachmann and Sidney O. Davis, Project Engineers, Air Force Materials Laboratory, Research and Technology Division.

This report covers work that was conducted between 27 June 1966 and 31 May 1967.

Manuscript released by authors, 31 May 1967.

Work was conducted under the direction of Mr. H. B. Sipple, Department Manager, Materials Engineering. Mr. R. M. Brockett was Engineering Project Leader. Technical consultation was provided by Mr. M. Tiktinsky, Group Engineer Metallic Materials, and by Mr. V. E. Dress and Mr. R. F. Simenz, Research Specialists. Static test programs were conducted under the direction of Miss Judith A. Gotthrath and fatigue testing under the direction of Mr. R. B. Urzi, with overall supervision of test activities by Mr. R. G. Adamson, Group Engineer, Materials Evaluation.

This technical report has been reviewed and is approved.



D. A. Shinn

Chief, Materials Information Branch
Materials Application Division
AF Materials Laboratory

ABSTRACT

Mechanical property data for Ti-6Al-4V, Ti-8Al-1Mo-1V and Ti-6Al-6V-2Sn extruded shapes in annealed tempers were obtained at test temperatures from -110°F to +800°F to provide a base for development of design information for these materials. Data obtained included ultimate tensile strength, tensile yield strength, compressive yield strength, shear, bearing, impact properties, creep, stress-rupture, fatigue, and fracture toughness characteristics.

Separate heats of material in each of the three alloys were obtained from separate suppliers. Two section sizes were obtained from one of the suppliers to provide information on size effects. Tests conducted provided data insofar as practicable within the scope of this program on property variations and on scatter.

Results of testing indicate that with consideration of effect of temperatures used in extrusion processing, extrusions may be utilized in the same manner as titanium materials produced by other methods such as rolling or forging. Data obtained generally indicate that extruded material may be expected to have not only the cost advantages which result from economy of shape design, but will possess advantages in delayed fracture characteristics and creep characteristics when compared with conventional alpha-beta processing of rolled or forged material.

(Distribution of this abstract is unlimited).

TABLE OF CONTENTS

| Section | | Page |
|---------|---|------|
| | FOREWORD | 11 |
| | ABSTRACT | 111 |
| | NOMENCLATURE | xv |
| I | SUMMARY | 1 |
| | Background | 1 |
| | Materials | 1 |
| | Test Objectives | 1 |
| | Test Results | 3 |
| II | MATERIAL | 13 |
| | Background | 13 |
| | Materials Producers | 13 |
| | Heat Treatments | 13 |
| | Processing Data | 14 |
| | Metallographic Control | 17 |
| III | MATERIALS PROPERTY TEST PROCEDURES | 21 |
| | Tensile Tests | 21 |
| | Compression Tests | 21 |
| | Tension and Compression Modulus of Elasticity | 21 |
| | Shear Tests | 21 |
| | Bearing Tests | 24 |
| | Temperature Effect Test Procedures | 24 |
| | Creep and Stress Rupture Tests | 24 |
| | Charpy Impact Tests | 26 |
| | Plane-Strain Fracture Toughness | 26 |
| | Delayed Failure Tests | 30 |
| | S-N Fatigue Tests | 30 |
| IV | DISCUSSION OF RESULTS | 33 |
| | Basis for Evaluations | 33 |
| | Uniformity of Properties | 33 |
| | Relationship Between Vendors | 40 |
| | Modulus of Elasticity | 40 |
| | Temperature Effects on Tensile and Compressive Properties | 40 |

TABLE OF CONTENTS (Continued)

| Section | | Page |
|---------|--|------|
| | Bearing | 44 |
| | Shear | 44 |
| | Creep and Stress Rupture | 44 |
| | Impact Properties | 57 |
| | Fracture Toughness and Delayed Failure | 59 |
| | Fatigue | 59 |
| V | PRELIMINARY DESIGN INFORMATION | 67 |
| | Ti-6Al-4V Tentative Design Properties | 67 |
| | Ti-8Al-1 Mo-1V Tentative Design Properties | 67 |
| | Ti-6Al-6V-2Sn Tentative Design Properties | 84 |
| VI | CONCLUSIONS AND RECOMMENDATIONS | 115 |
| | APPENDIX - TABULATION OF TEST RESULTS | 117 |

LIST OF FIGURES

| <u>Figure</u> | | <u>Page</u> |
|---------------|---|-------------|
| 1 | Cross Section, Thin Extrusion | 2 |
| 2 | Cross Section, Thick Extrusion | 2 |
| 3 | Comparison of Typical Fracture Toughness and Delayed Failure Characteristics of Ti-6Al-4V, Ti-8Al-1Mo-1V and Ti-6Al-6V-2Sn Extrusions, and Typical Forgings and Bar | 4 |
| 4 | Comparative Creep Characteristics of Extrusions and Other Product Forms | 5 |
| 5 | Comparison of Typical Ultimate Tensile Strengths of Ti-6Al-4V, Ti-8Al-1Mo-1V and Ti-6Al-6V-2Sn Extrusions at Various Temperatures | 6 |
| 6 | Comparison of Typical Tensile Yield Strengths of Ti-6Al-4V, Ti-8Al-1Mo-1V and Ti-6Al-6V-2Sn Extrusions at Various Temperatures | 7 |
| 7 | Comparison of Typical Compressive Yield Strengths of Ti-6Al-4V, Ti-8Al-1Mo-1V and Ti-6Al-6V-2Sn Extrusions at Various Temperatures | 8 |
| 8 | Comparative Short Time, Rapid Heat and Load Creep Characteristics at 800°F Yield Strength | 9 |
| 9 | Comparative Short Time Rapid Heat and Load Creep Characteristics at 800°F | 10 |
| 10 | Comparative Maximum Stresses for 10^5 , and 10^7 cycles for Ti-6Al-4V, Ti-8Al-1Mo-1V and Ti-6Al-6V-2Sn Extrusions | 12 |
| 11 | Macrostructure and Microstructure of Ti-6Al-4V Extrusion | 18 |
| 12 | Macrostructure and Microstructure of Ti-8Al-1Mo-1V Extrusion | 19 |
| 13 | Macrostructure and Microstructure of Ti-6Al-6V-2Sn Extrusion | 20 |
| 14 | Round Tensile Specimen | 22 |
| 15 | Flat Tensile Specimen | 22 |
| 16 | Compression Specimen | 22 |
| 17 | Shear Specimen | 23 |

LIST OF FIGURES (Continued)

| <u>Figure</u> | | <u>Page</u> |
|---------------|--|-------------|
| 18 | Bearing Specimen | 23 |
| 19 | Creep and Stress Rupture Specimen | 25 |
| 20 | Charpy Specimen, Thick Extrusion | 27 |
| 21 | Charpy Specimen, Thin Extrusion | 27 |
| 22 | Fatigue Cracked Bend Specimen, Thick Extrusion | 28 |
| 23 | Fatigue Cracked Bend Specimen, Thin Extrusion | 29 |
| 24 | Smooth Fatigue Specimen | 31 |
| 25 | Notched Fatigue Specimen | 31 |
| 26 | Comparison of Variation in TUS and TYS with Location in Cross Section, in Length, and Between Vendors, Sections and Heats Ti-6Al-4V Extrusions | 37 |
| 27 | Comparison of Variation in TUS and TYS with Location in Cross Section, in Length, and Between Vendors, Sections and Heats Ti-8Al-1Mo-1V Extrusions | 38 |
| 28 | Comparison of Variation in TUS and TYS with Location in Cross Section, in Length, and Between Vendors, Sections, and Heats, Ti-6Al-6V-2Sn Extrusions | 39 |
| 29 | Typical Distribution of Test Results Annealed Ti-6Al-4V Extrusions | 41 |
| 30 | Typical Distribution of Test Results Annealed Ti-6Al-6V-2Sn Extrusions | 42 |
| 31 | Typical Distribution of Test Results Annealed Ti-8Al-1Mo-1V Extrusions | 43 |
| 32 | Comparison of Effect of Temperature On Ultimate Tensile Strength of Annealed Ti-6Al-4V Extrusion and Ti-6Al-4V Sheet and Bar | 47 |
| 33 | Comparison of Effect of Temperature on the Tensile Yield Strength of Annealed Ti-6Al-4V Extrusion and Ti-6Al-4V Sheet and Bar | 48 |
| 34 | Comparison of Effect of Temperature on the Compressive Yield Strength of Annealed Ti-6Al-4V Extrusion and Ti-6Al-4V Sheet and Bar | 49 |
| 35 | Comparison of Effect of Temperature on the Ultimate Tensile Strength of Annealed Ti-8Al-1Mo-1V Extrusion and Ti-8Al-1Mo-1V Sheet | 50 |

LIST OF FIGURES (Continued)

| <u>Figure</u> | | <u>Page</u> |
|---------------|---|-------------|
| 36 | Comparison of Effect of Temperature on the Tensile Yield Strength of Annealed Ti-8Al-1Mo-1V Extrusion and Ti-8Al-1Mo-1V Sheet | 51 |
| 37 | Comparison of Effect of Temperature on the Compressive Yield Strength of Annealed Ti-8Al-1Mo-1V Extrusion and Ti-8Al-1Mo-1V Sheet | 52 |
| 38 | Comparison of Effect of Temperature on the Ultimate Tensile Strength of Annealed Ti-6Al-6V-2Sn Extrusion and Ti-6Al-6V 2Sn Forgings | 53 |
| 39 | Comparison of Effect of Temperature on the Tensile Yield Strength of Annealed Ti-6Al-6V-2Sn Extrusion and Ti-6Al-6V-2Sn Forgings | 54 |
| 40 | Charpy Impact Properties of Ti-6Al-4V Extrusions | 60 |
| 41 | Charpy Impact Properties of Ti-8Al-1Mo-1V Extrusions | 61 |
| 42 | Charpy Impact Properties of Ti-6Al-6V-2Sn Extrusions | 62 |
| 43 | Delayed Failure Characteristics of Ti-6Al-4V Extrusions | 63 |
| 44 | Delayed Failure Characteristics of Ti-8Al-1Mo-1V Extrusions | 64 |
| 45 | Delayed Failure Characteristics of Ti-6Al-6V-2Sn Extrusions | 65 |
| 46 | Effect of Temperature on the Ultimate Tensile Strength (F_{tu}) of Annealed Ti-6Al-4V Extrusions | 69 |
| 47 | Effect of Temperature on the Tensile Yield Strength (F_{ty}) of Annealed Ti-6Al-4V Extrusions | 70 |
| 48 | Effect of Temperature on the Compressive Yield Strength (F_{cy}) of Annealed Ti-6Al-4V Extrusions | 71 |
| 49 | Effect of Temperature on the Ultimate Shear Strength (F_{su}) of Ti-6Al-4V Extrusions | 72 |
| 50 | Effect of Temperature on the Ultimate Bearing Strength (F_{bru}) of Ti-6Al-4V Extrusions | 73 |
| 51 | Effect of Temperature on the Bearing Yield Strength (F_{bry}) of Ti-6Al-4V Extrusions | 74 |
| 52 | Typical Tensile Stress-Strain Curve for Ti-6Al-4V Extrusion at Room Temperature | 75 |
| 53 | Typical Compression Stress-Strain Curve for Ti-6Al-4V Extrusion at Room Temperature | 76 |

LIST OF FIGURES (Continued)

| Figure | | Page |
|--------|--|------|
| 54 | Typical S/N Fatigue Curve for $K_T = 1.0$, Ti-6Al-4V Extrusions at Room Temperature | 77 |
| 55 | Typical S/N Fatigue Curves for $K_T = 2.76$ ($A = \infty$, $A = 0.98$, $A = 0.4$), Ti-6Al-4V Extrusions at Room Temperature | 78 |
| 56 | Typical S/N Fatigue Curves for $K_T = 2.76$ ($A = \infty$, $A = 0.98$, $A = 0.4$), Ti-6Al-4V Extrusions at 400F | 79 |
| 57 | Typical S/N Fatigue Curves for $K_T = 2.76$ ($A = \infty$, $A = 0.98$, $A = 0.4$), Ti-6Al-4V Extrusions at 600F | 80 |
| 58 | Constant-life Fatigue Diagram for Notched Ti-6Al-4V Annealed Extrusions at Room Temperature | 81 |
| 59 | Constant-life Fatigue Diagram for Notched Ti-6Al-4V Annealed Extrusions at 400F and 600F | 82 |
| 60 | Effect of Temperature on the Ultimate Tensile Strength (F_{tu}) of Annealed Ti-8Al-1Mo-1V Extrusions | 85 |
| 61 | Effect of Temperature on the Tensile Yield Strength (F_{ty}) of Annealed Ti-8Al-1Mo-1V Extrusions | 86 |
| 62 | Effect of Temperature on the Compressive Yield Strength (F_{cy}) of Annealed Ti-8Al-1Mo-1V Extrusions | 87 |
| 63 | Effect of Temperature on the Ultimate Shear Strength (F_{su}) of Ti-8Al-1Mo-1V Extrusions | 88 |
| 64 | Effect of Temperature on the Ultimate Bearing Strength (F_{bru}) of Ti-8Al-1Mo-1V Extrusions | 89 |
| 65 | Effect of Temperature on the Bearing Yield Strength (F_{brv}) of Ti-8Al-1Mo-1V Extrusions | 90 |
| 66 | Typical Tensile Stress-Strain Curve for Ti-8Al-1Mo-1V Extrusions at Room Temperature | 91 |
| 67 | Typical Compression Stress-Strain Curve for Ti-8Al-1Mo-1V Extrusion at Room Temperature | 92 |
| 68 | Typical S/N Fatigue Curve for $K_T = 1.0$, Ti-8Al-1Mo-1V Extrusions at Room Temperature | 93 |
| 69 | Typical S/N Fatigue Curves for $K_T = 2.76$ ($A = \infty$, $A = 0.98$, $A = 0.4$) Ti-8Al-1Mo-1V Extrusions at Room Temperature | 94 |
| 70 | Typical S/N Fatigue Curves for $K_T = 2.76$ ($A = \infty$, $A = 0.98$, $A = 0.4$) Ti-8Al-1Mo-1V Extrusions at 400F | 95 |
| 71 | Typical S/N Fatigue Curves for $K_T = 2.76$ ($A = \infty$, $A = 0.98$, $A = 0.4$) Ti-8Al-1Mo-1V Extrusions at 600F | 96 |

LIST OF FIGURES (Continued)

| Figure | | Page |
|--------|--|------|
| 72 | Constant-Life Fatigue Diagram for Notched Ti-8Al-1Mo-1V Annealed Extrusions at Room Temperature | 98 |
| 73 | Constant-Life Fatigue Diagram for Notched Ti-8Al-1Mo-1V Annealed Extrusions at 400F and 600F | 99 |
| 74 | Effect of Temperature of Temperature on the Ultimate Tensile Strength (F_{tu}) of Annealed Ti-6Al-6V-2Sn Extrusions | 100 |
| 75 | Effect of Temperature on the Tensile Yield Strength (F_{ty}) of Annealed Ti-6Al-6V-2Sn Extrusions | 101 |
| 76 | Effect of Temperature on the Compressive Yield Strength (F_{cy}) of Annealed Ti-6Al-6V-2Sn Extrusions | 102 |
| 77 | Effect of Temperature on the Ultimate Shear Strength (F_{su}) of Ti-6Al-6V-2Sn Extrusions | 103 |
| 78 | Effect of Temperature on the Ultimate Bearing Strength (F_{bru}) of Ti-6Al-6V-2Sn Extrusions | 104 |
| 79 | Effect of Temperature on the Bearing Yield Strength (F_{bry}) of Ti-6Al-6V-2Sn Extrusions | 105 |
| 80 | Typical Tensile Stress-Strain Curve for Ti-6Al-6V-2Sn Extrusion at Room Temperature | 106 |
| 81 | Typical Compression Stress-Strain Curve for Ti-6Al-6V-2Sn Extrusion at Room Temperature | 107 |
| 82 | Typical S/N Fatigue Curve for $K_T = 1.0$, Ti-6Al-6V-2Sn Extrusions at Room Temperature | 108 |
| 83 | Typical S/N Fatigue Curves for $K_T = 2.76$, ($A = \infty$, $A = 0.98$, $A = 0.4$) Ti-6Al-6V-2Sn Extrusions at Room Temperature | 109 |
| 84 | Typical S/N Fatigue Curves for $K_T = 2.76$, ($A = \infty$, $A = 0.98$, $A = 0.4$) Ti-6Al-6V-2Sn Extrusions at 400F | 110 |
| 85 | Typical S/N Fatigue Curves for $K_T = 2.76$, ($A = \infty$, $A = 0.98$, $A = 0.4$) Ti-6Al-6V-2Sn Extrusions at 600F | 111 |
| 86 | Constant-Life Fatigue Diagram for Notched Ti-6Al-6V-2Sn Annealed Extrusions at Room Temperature | 112 |
| 87 | Constant-Life Fatigue Diagram for Notched Ti-6Al-6V-2Sn Annealed Extrusions at 400F and 600F | 113 |

LIST OF FIGURES (Continued)

| Figure | | Page |
|--------|---|------|
| 88 | Typical Cross Section Locations, Longitudinal Specimens | 119 |
| 89 | Typical Cross Section Locations Transverse Specimens | 120 |
| 90 | Specimen Locations, Pieces I and III (Part of) | 121 |
| 91 | Specimen Locations, Piece I (cont) | 123 |
| 92 | Specimen Locations, Piece III (cont) | 125 |
| 93 | Specimen Locations Pieces II and IV | 127 |
| 94 | Specimen Locations, Piece V, Thick Extrusions | 129 |

LIST OF TABLES

| Table | | Page |
|-------|--|------|
| I | Chemical Composition of Test Extrusions | 15 |
| II | Extrusion Processing History | 16 |
| III | Ti-6Al-4V Extrusions, Variation in Properties with Cross Section Location, Position in Length, and Piece | 34 |
| IV | Ti-8Al-1Mo-1V Extrusions, Variation in Properties with Cross Section Location, Position in Length, and Piece | 35 |
| V | Ti-6Al-6V-2Sn Extrusions, Variation in Properties with Cross Section Location, Position in Length, and Piece | 36 |
| VI | Effect of Temperature on Ultimate Tensile Strength of Titanium Alloy Extrusions | 45 |
| VII | Effect of Temperature on the Tensile Yield Strength of Titanium Alloy Extrusions | 45 |
| VIII | Effect of Temperature on the Compressive Yield Strength of Titanium Alloy Extrusions | 46 |
| IX | Ultimate Bearing Strengths of Titanium Alloy Extrusions | 55 |
| X | Bearing Yield Strengths of Titanium Alloy Extrusions | 56 |
| XI | Shear Strength of Titanium Alloy Extrusions | 57 |
| XII | Comparison of Creep Strain Under Varying Loading Conditions | 58 |
| XIII | Fracture Toughness and Delayed Failure Characteristics of Titanium Alloy Extrusions | 66 |
| XIV | Tentative Design Mechanical and Physical Properties of Ti-6Al-4V Titanium Alloy (Extrusions) | 68 |
| XV | Tentative Design Mechanical and Physical Properties of Ti-8Al-1Mo-1V Titanium Alloy (Extrusions) | 83 |
| XVI | Tentative Design Mechanical and Physical Properties of Ti-6Al-6V-2Sn Titanium Alloy (Extrusions) | 99 |
| XVII | Tensile Test Summary | 131 |
| XVIII | Compression Test Summary | 142 |

LIST OF TABLES (Continued)

| Table | | Page |
|--------|--|------|
| XXIX | Tensile Modulus Summary | 150 |
| XX | Bearing Test Summary | 151 |
| XXI | Shear Test Summary | 157 |
| XXII | Charpy Impact Test Summary | 162 |
| XXIII | Fracture Toughness Test Summary | 165 |
| XXIV | Delayed Failure Test Summary | 167 |
| XXV | Creep Test Summary | 169 |
| XXVI | Rapid Heat and Load Creep Test Summary | 177 |
| XXVII | Fatigue Test Summary, $K_T = 1.0$ | 183 |
| XXVIII | Fatigue Test Summary $K_T = 2.76$, Room Temperature | 187 |
| XXIX | Fatigue Test Summary $K_T = 2.76$, 400°F | 190 |
| XXX | Fatigue Test Summary $K_T = 2.76$, 600°F | 194 |

NOMENCLATURE

| | |
|------------|---|
| TUS | Tensile Ultimate Strength, observed value |
| TYS | Tensile Yield Strength, observed value |
| CYS | Compressive Yield Strength, observed value |
| F_{tu} | Ultimate Tensile Strength, room temperature minimum value |
| F_{ty} | Tensile Yield Strength, room temperature minimum value |
| F_{cy} | Compressive Yield Strength, room temperature minimum value |
| F_{bru} | Bearing Ultimate Strength, room temperature minimum value |
| F_{bry} | Bearing Yield Strength, room temperature minimum value |
| F_{sw} | Shear Ultimate Strength, room temperature minimum value |
| K_{Ic} | Plane Strain Critical Stress Intensity Factor (Fracture Toughness) |
| K_{I1} | Sustained load environmental stress intensity limit (Delayed Failure) |
| A | Ratio of Alternating Stress (Fatigue Tests) to Mean Stress |
| K_T | Theoretical Stress Concentration Factor |
| L | Longitudinal |
| T | Transverse |
| ksi | Kips (1000 pounds) per square inch |
| f_{max} | Highest Value of Gross Area Stress |
| f_{mean} | Mean Gross Area Stress |
| N | Number of Cycles |
| R | Ratio of Minimum to Maximum Stress |
| RT | Room Temperature |

Section I

SUMMARY

BACKGROUND

Major increases have occurred in the use of titanium alloy extruded shapes for aerospace applications. These applications include sub-sonic systems operating in conventional environments where advantage is taken of titanium's favorable strength to density relationship and supersonic vehicles where the elevated temperature strength of titanium is exploited.

Today's typical titanium extrusion is produced using billet temperatures such that final working occurs in the beta field with the result that the metallurgical structure differs from that of products such as sheet and plate, bar, or forgings where final processing occurs in the alpha-beta field. The gross titanium extrusion produced, while producing radical savings in material because of closer shape approximation, requires overall machining since tolerances and surface conditions are not suitable for direct application, and since an alpha case on the extrusion must be removed to provide a satisfactory metallurgical surface.

Since the bulk of the present published data on properties of titanium alloys has been determined using rolled sheet and bar material or using forged material with final hot working occurring below the beta transus, this program has been established to provide a base of data from which values necessary for reliable design can be established when analyzed in conjunction with data from other sources.

MATERIALS

Annealed material in each of three alloys, Ti-6Al-4V, Ti-8Al-1Mo-1V and Ti-6Al-6V-2Sn was obtained from two vendors for analysis. The thin tee section, Figure 1, was supplied by both vendors to provide data on effect of heat and source on test results. A heavier section, Figure 2, was also obtained in each alloy from one of the vendors in order to probe size effect on annealed extrusions, and in order to expand the data base.

TEST OBJECTIVES

Mechanical property tests were conducted with the Ti-6Al-4V, Ti-8Al-1Mo-1V, and Ti-6Al-6V-2Sn extrusions at temperatures ranging from -110°F to 800°F. Tests included tensile and compressive property determinations, shear and bearing, creep and stress rupture, fracture and delayed failure properties, impact properties, and fatigue characteristics.

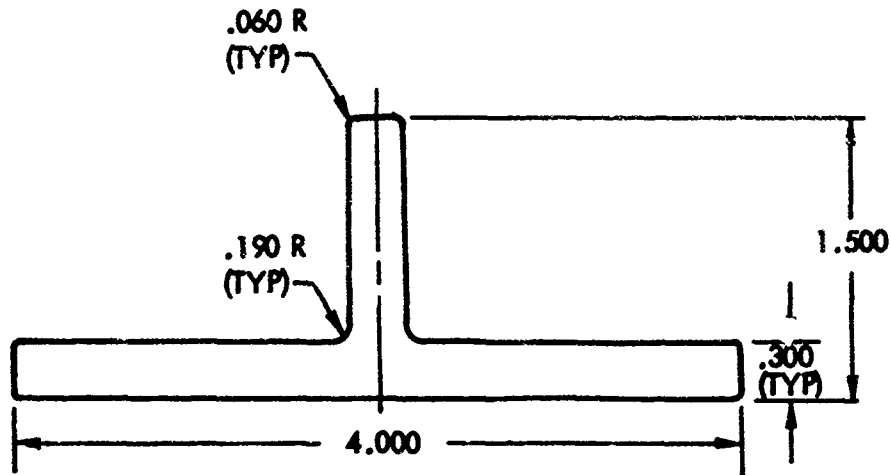

Figure 1. Thin Extrusion

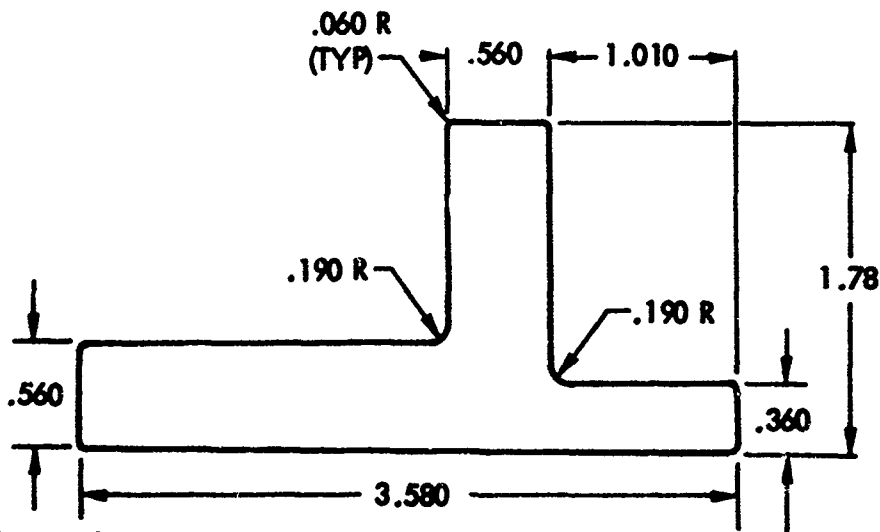

Figure 2. Thick Extrusion

TEST RESULTS

Orientation of testing and analysis of data has been directed in such manner as to define relative advantages and limitations of extruded materials in comparison to competitive alternates. Presentation has been directed toward development of MIL-NDBK-5 data when supplemented by data from other sources.

Room temperature tensile and compressive properties were analyzed to establish that properties are uniform within a piece, including cross-section location and position in length. Variations between vendors could not be evaluated on a meaningful basis within scope of this program, but can be determined from vendor test statistics. Present specification values accepted by producers are consistent with those offered for other product forms with the exception of elongation and reduction of area.

The effect of temperature on properties appeared to reflect a consistent relationship between vendors and heats.

The extruded product, with its beta worked structure appears to offer advantages in resistance to delayed failure (Figure 3), and in resistance to creep (Figure 4).

Properties of the alloys followed normal patterns, alloy Ti-6Al-6V-2Sn showing highest strengths, while Ti-8Al-1Mo-1V possessed best toughness and the highest tensile modulus. Comparative typical ultimate tensile strengths, tensile yield strengths and compressive yield strengths are shown in Figures 5, 6, and 7. Ti-6Al-6V-2Sn showed lower resistance to creep at elevated temperatures than the other alloys. Comparative resistance to creep of the three materials under rapid heat-rapid load test conditions is shown in Figures 8 and 9.

Ti-6Al-6V-2Sn provides the highest level of strength at any of the temperatures investigated. As an annealed product, it furnishes strength levels comparable to an intermediate level of Ti-6Al-4V heat treated and aged. Ductility and toughness are generally considered to be inferior to the other two alloys, Ti-6Al-4V and Ti-8Al-1Mo-1V. At elevated temperatures Ti-6Al-6V-2Sn appears more sensitive to creep than the other two materials but none appear to be creep limited at anticipated operating temperatures. Effect of elevated temperature on this alloy seems less severe than effect on the other two alloys.

Ti-8Al-1Mo-1V possesses favorable modulus and favorable density values. Toughness of this alloy appears excellent. Delayed failure characteristics of Ti-8Al-1Mo-1V appear unfavorable however, as shown in Figure 3, and have limited consideration of Ti-8Al-1Mo-1V for applications in general airframe use. The elevated temperature properties, particularly resistance to creep in hot areas, indicate possible specialized usages particularly suitable to Ti-8Al-1Mo-1V.

Ti-6Al-4V provides a good combination of strength, toughness not offered by Ti-6Al-6V-2Sn and environmental resistance. These qualities, coupled with production reliability and low cost tend to make this the present preferred alloy

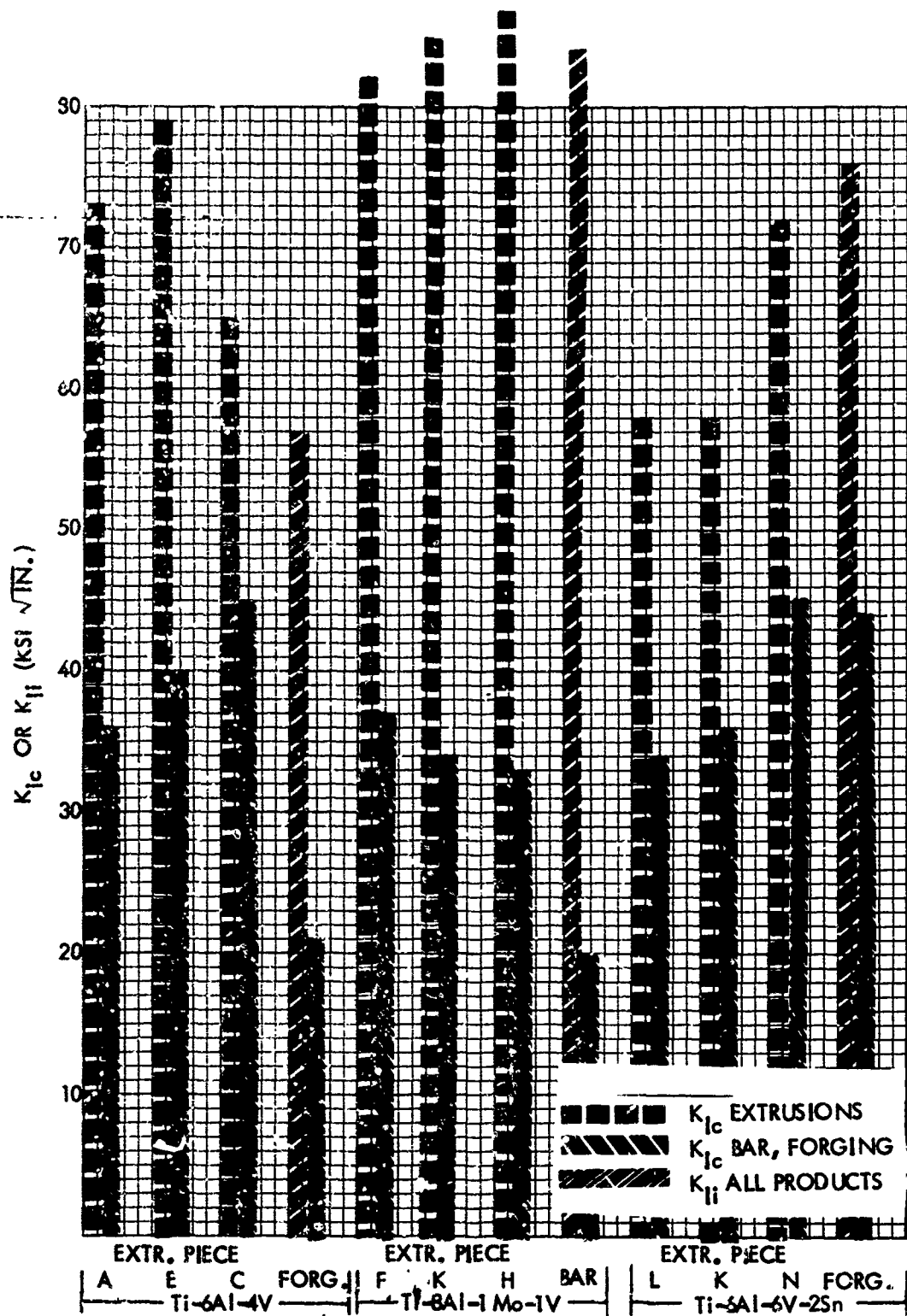

Figure 3. Comparison of Typical Fracture Toughness and Delayed Failure Characteristics of Ti-6Al-4V, Ti-8Al-1Mo-1V and Ti-6Al-6V-2Sn Extrusions, and Typical Forgings and Bar

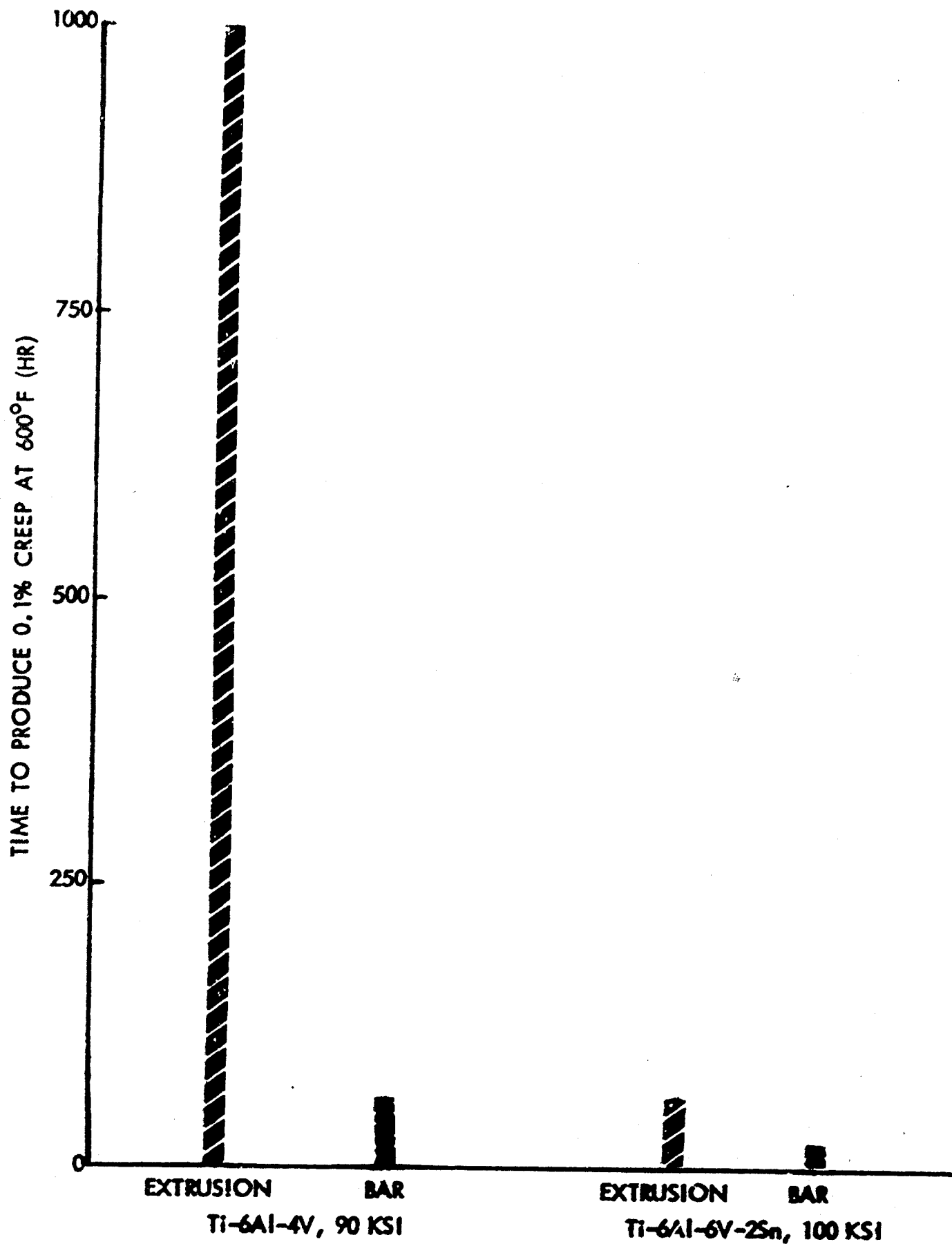

Figure 4. Comparative Creep Characteristics Extrusions and Bar, Typical Data

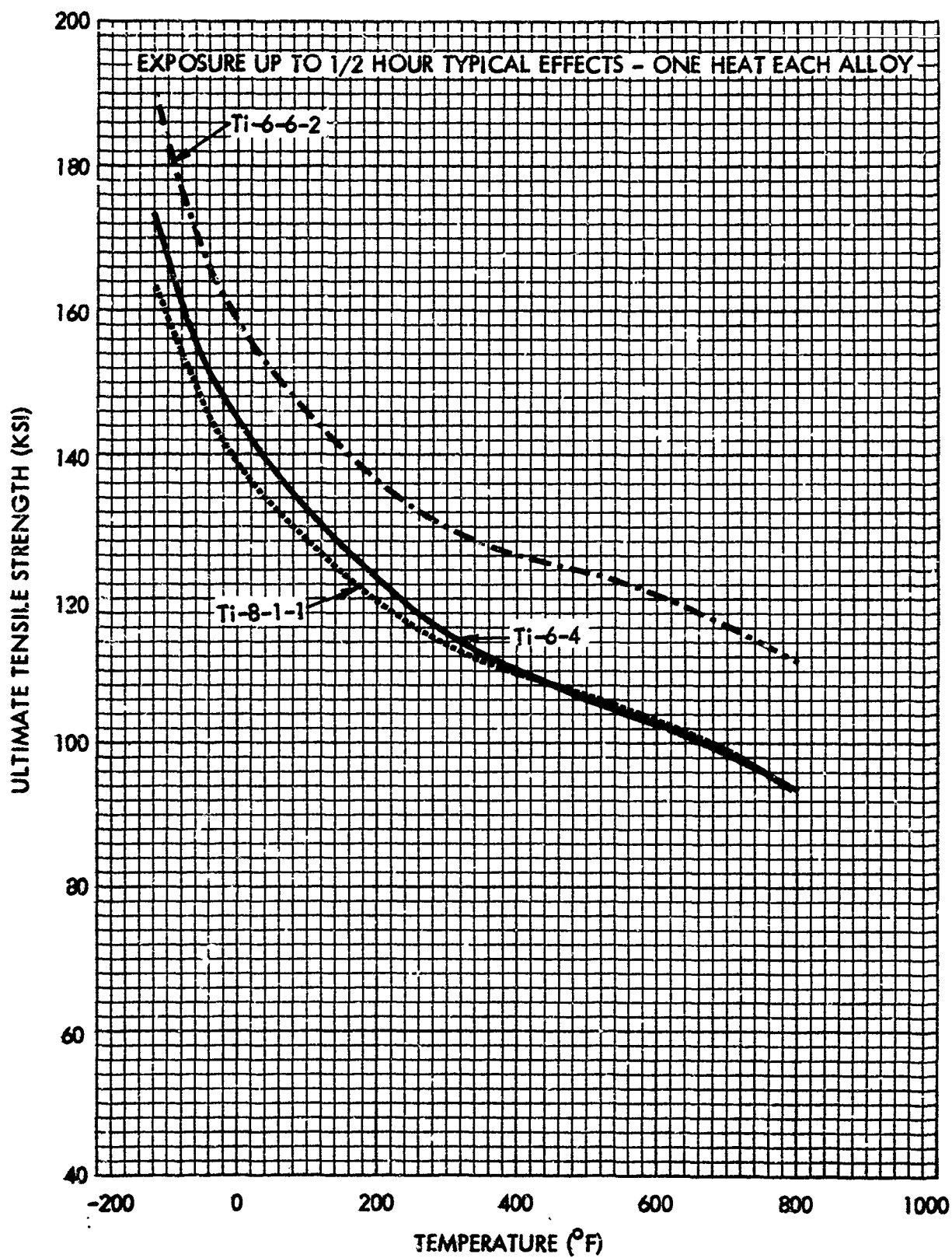

Figure 5. Comparison of Typical Ultimate Tensile Strengths of Ti-6Al-4V, Ti-8Al-1Mo-1V and Ti-6Al-6V-2Sn Extrusions at Various Temperatures

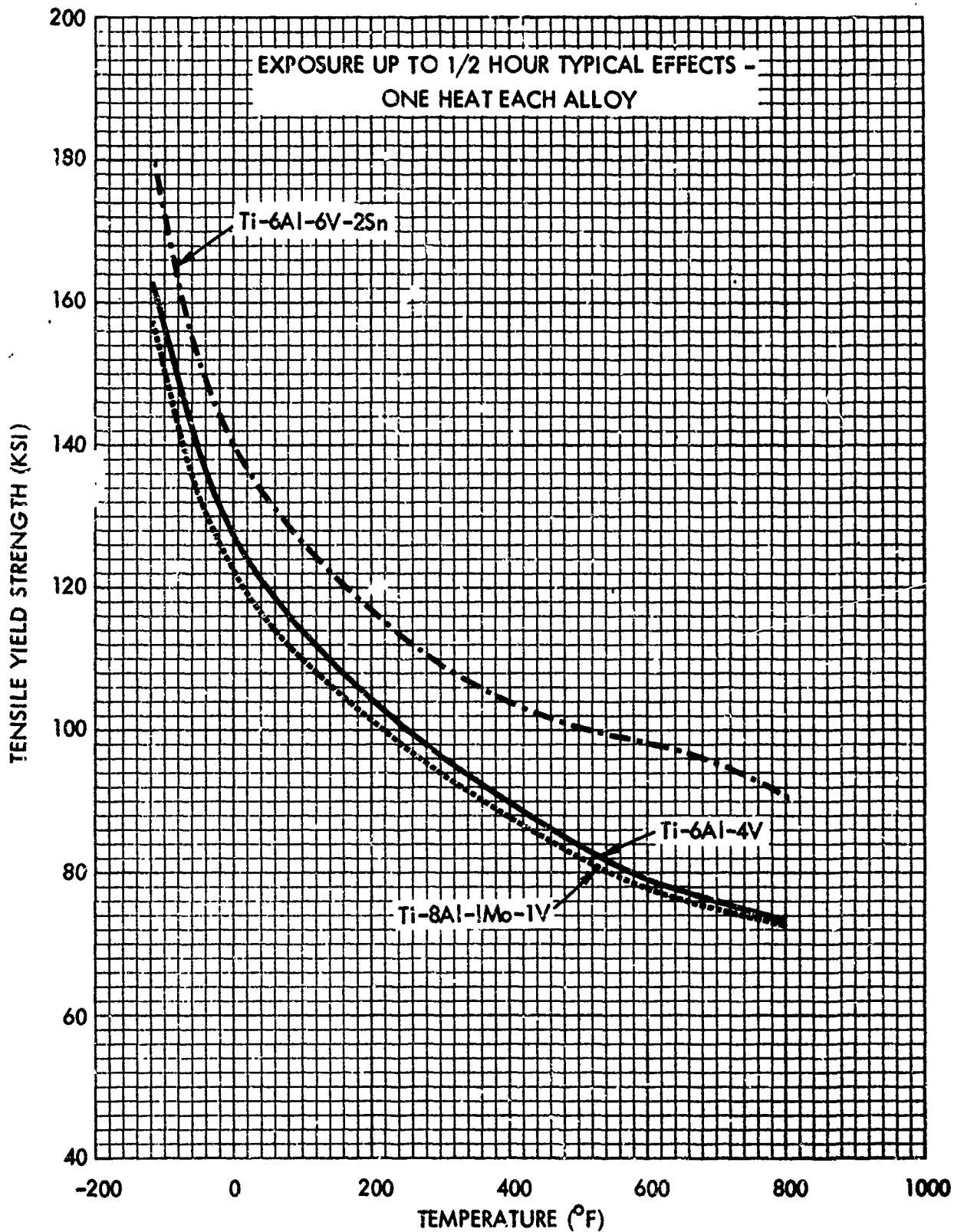

Figure 5. Comparison of Typical Tensile Yield Strengths of Ti-6Al-4V, Ti-8Al-1Mo-1V and Ti-6Al-6V-2Sn Extrusions at Various Temperatures

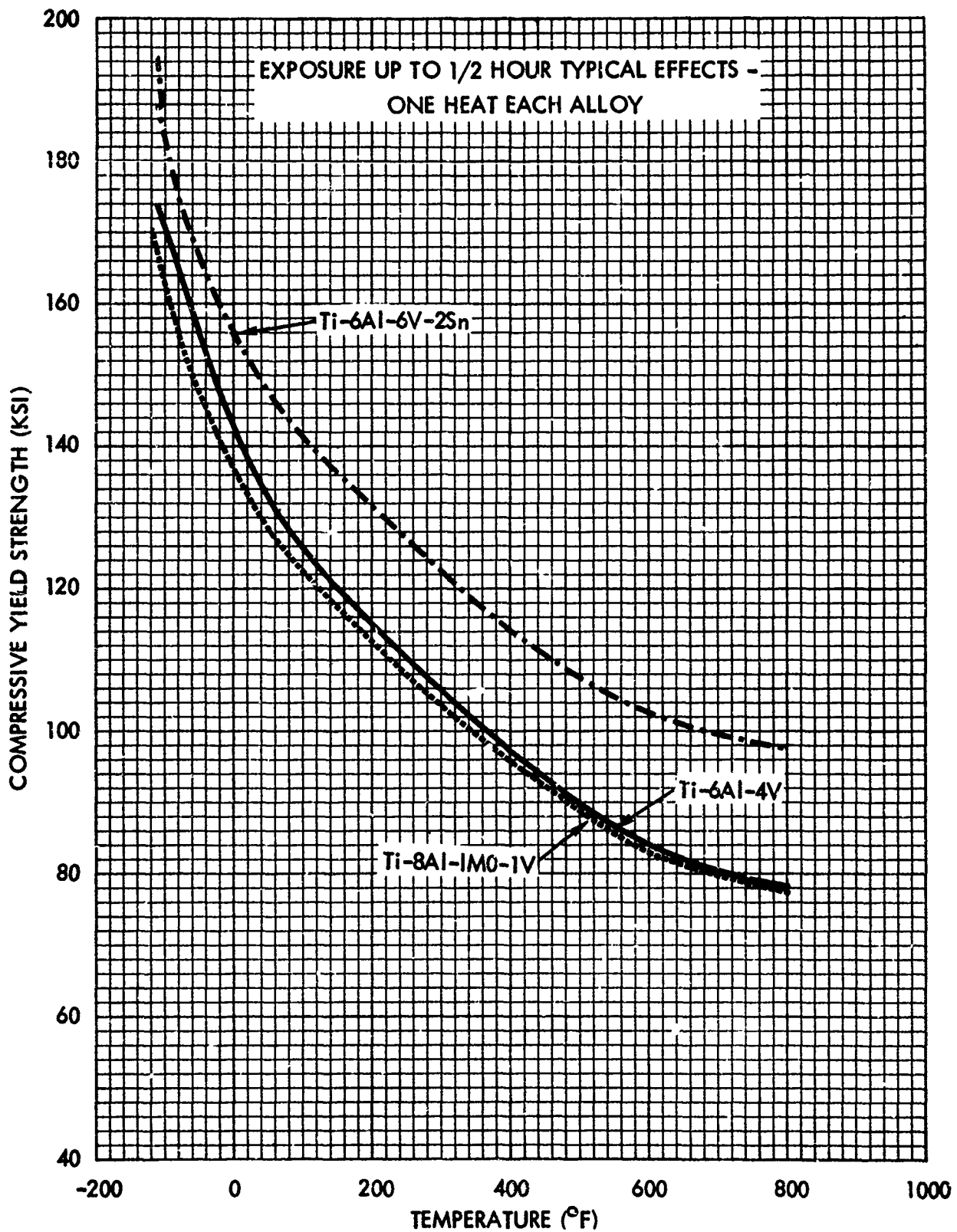

Figure 7. Comparison of Typical Compressive Yield Strengths of Ti-6Al-4V, Ti-8Al-1Mo-1V and Ti-6Al-6V-2Sn Extrusions at Various Temperatures

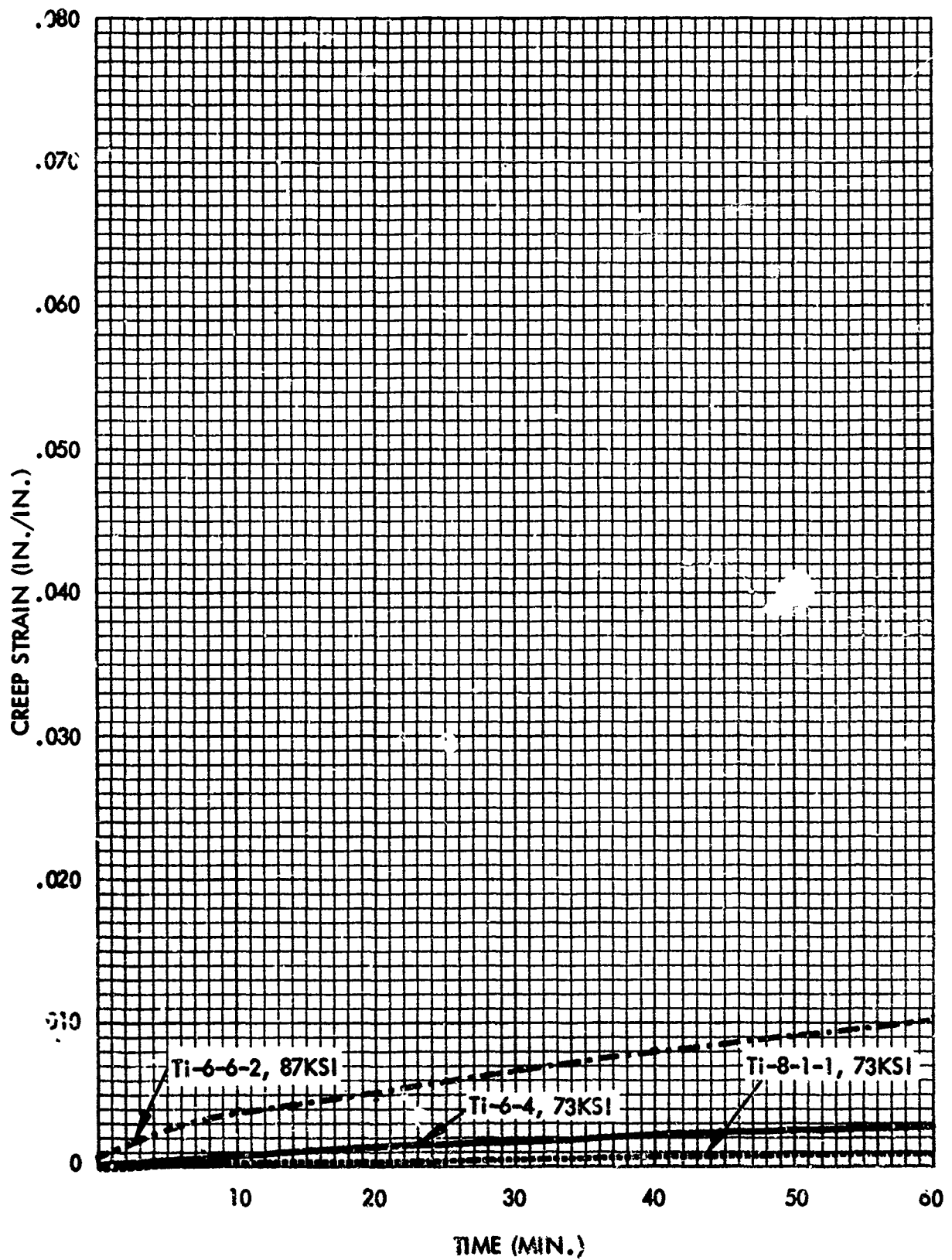

Figure 8. Comparative Short Time Rapid Heat and Load Creep Characteristics at 900°F Yield Strength

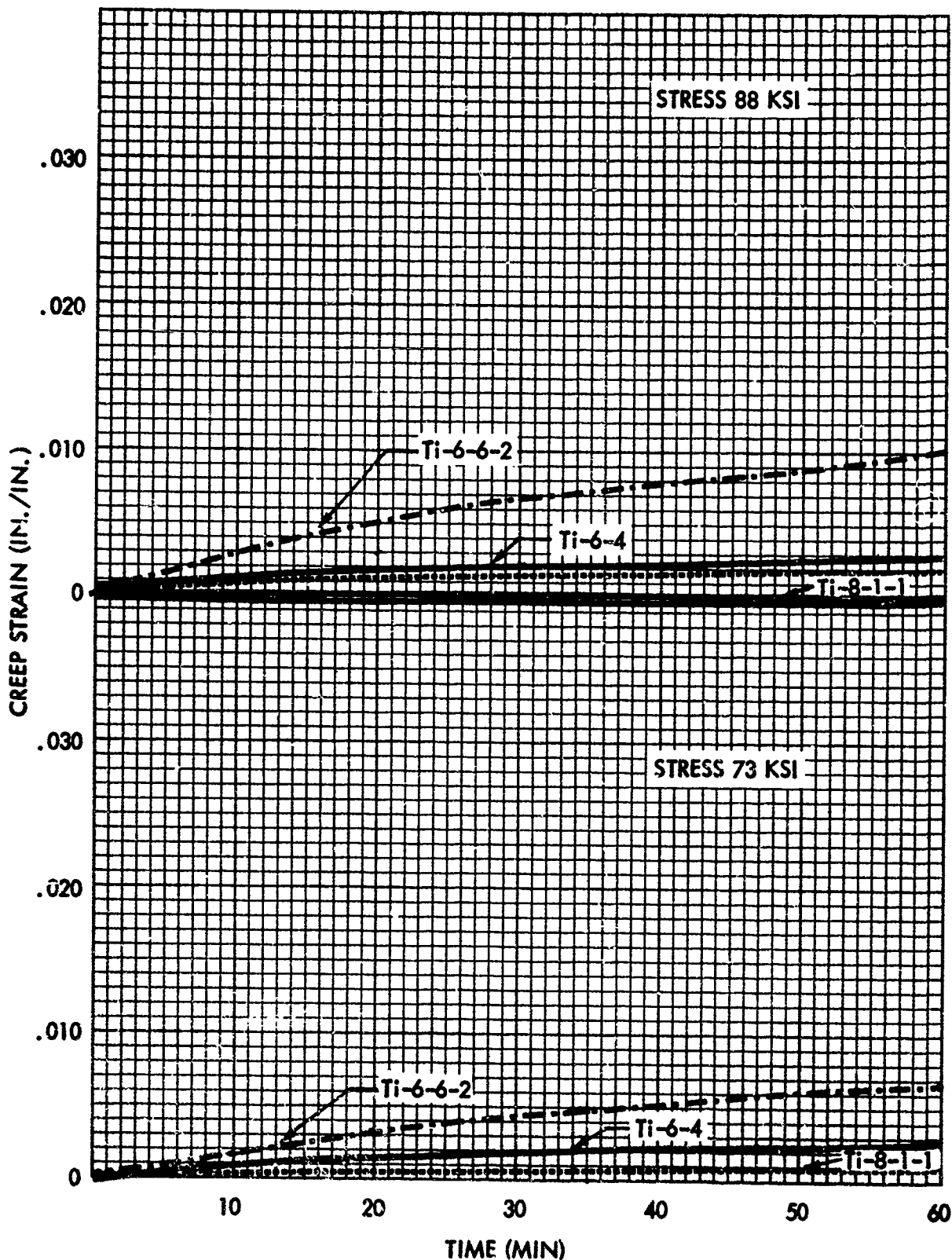

Figure 9. Comparative Short Time Rapid Heat and Load Creep Characteristics at 800°F

choice except for instances where requirements dictate exploiting the special peculiarities of the other alloys.

Within overall data compilations, the fatigue characteristics of the three alloys appear comparable. Figure 10 compares typical fatigue characteristics at various lives.

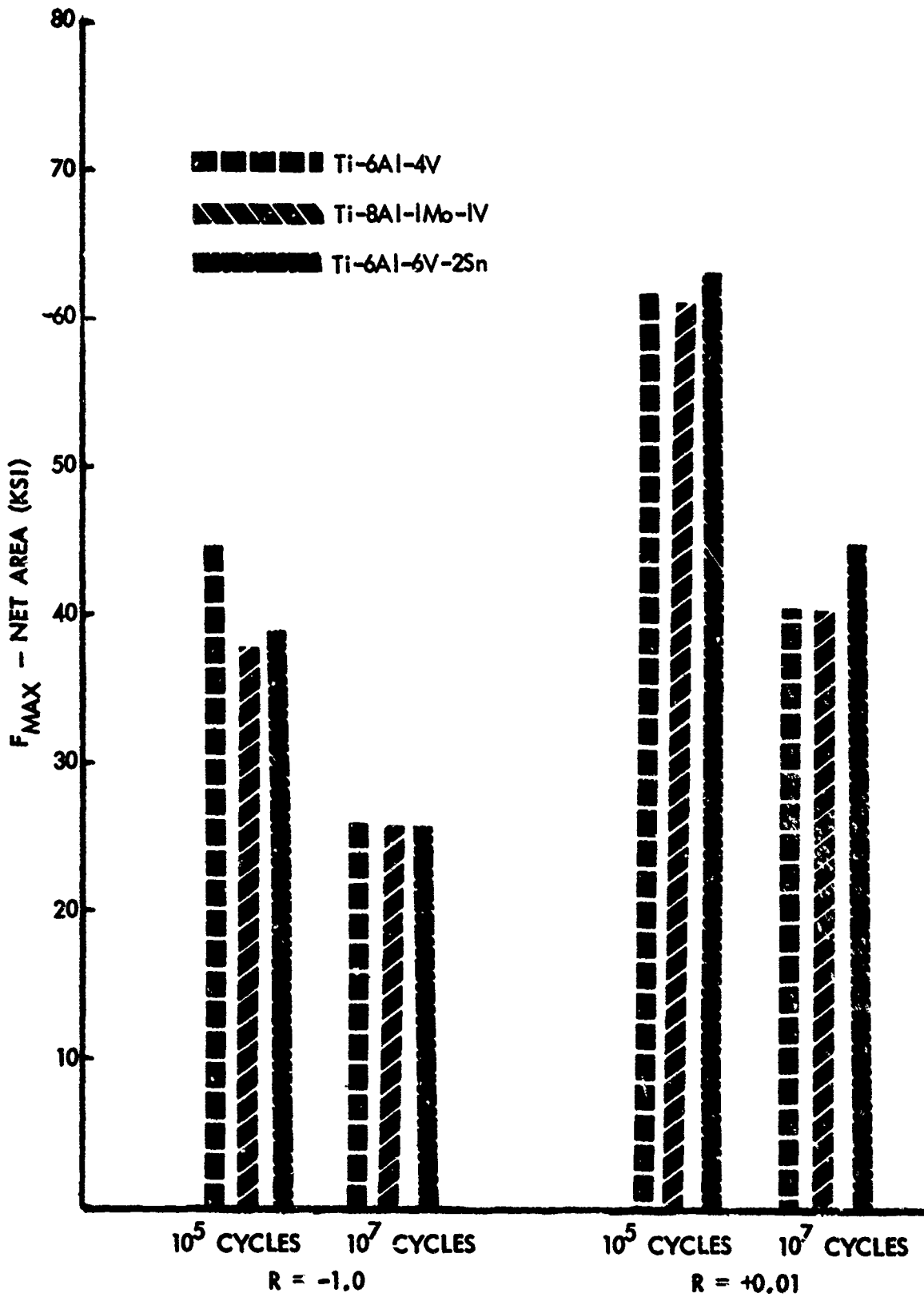

Figure 10. Comparative Maximum Stresses for 10⁵ and 10⁷ Cycles for Ti-6Al-4V, Ti-8Al-1Mo-1V and Ti-6Al-6V-2Sn Extrusions Typical Values, Room Temperature, $K_T = 2.76$

Section II

MATERIAL

BACKGROUND

Billet temperatures used in the extrusion of titanium alloy shapes are typically above the beta transus of the material - at temperatures which result in a metallurgical structure which differs markedly from that of other product forms such as sheet and plate, rod and bar, and forgings which normally have a final work in the alpha-beta field. Reduction ratios used in extrusion are higher than those used in other product types, and cooling in air occurs quite rapidly. Because of these, and other basic differences in the manufacturing processes, it has been necessary to establish material properties specifically for titanium extrusions.

MATERIALS PRODUCERS

Material for testing in this program was extruded by Harvey Aluminum, Torrance, California, and by the H.M. Harper Company, Morton Grove, Illinois. Harvey supplied both the thin extrusion, Figure 1, and the thick extrusion, Figure 2. Harper supplied material in the thin configuration only. Processing procedures used by the two producers were similar, except Harper utilized hot stretching as a standard straightening procedure, while Harvey utilized other straightening techniques.

HEAT TREATMENTS

Heat treatments used in these evaluations were selected to be generally applicable and acceptable in aerospace design, offering high levels of fracture toughness and resistance to delayed failure in salt water.

Since the present program was designed to test one heat treatment type only in each of the three alloys, annealed tempers were selected as being most representative for present use.

Annealing temperatures selected correspond with the standard temperatures shown for the alloys in MIL-H-81200, and in other standard industry documents. The soaking time at temperature was established with consideration of the section thicknesses involved. Air cooling from the annealing temperature to room temperature was used, since normally toughness characteristics with this processing are superior to those obtained with slow furnace cooling through part of the temperature range. For example, an extruded shape in Ti-6Al-4V tested in another program showed delayed fracture property (K_{T1}) of 46 ksi for air cooled material and 31 ksi for material from the same extrusion annealed and furnace cooled to 1000°F. Straightening after annealing was restricted to

avoid any residual Bauschinger effect. Time and temperature relationships are such that values obtained coordinate closely with existing producer data. Heat treatment schedules are shown below.

HEAT TREATMENT SCHEDULE

| Alloy | Temperature ($\pm 25^\circ$) | Time | Cooling |
|---------------|-----------------------------------|------------|------------------------|
| Ti-6Al-4V | 1300°F | 40-60 Min. | Air cool to room temp. |
| Ti-8Al-1Mo-1V | 1450°F | 40-60 Min. | Air cool to room temp. |
| Ti-6Al-6V-2Sn | 1300°F | 40-60 Min. | Air cool to room temp. |

Application of data from this program, and comparisons made with other data must be predicated on generally comparable heat treatment schedules.

PROCESSING DATA

Material from Harvey was cast as a 24-inch diameter ingot by the Consumable Electrode Vacuum Melt process by the Special Metals Division of Harvey Aluminum. The 24-inch ingot was forged to furnish a lathe turned six-inch diameter for the thin extrusion (pieces A, B, F, G, L, M) and a seven-inch diameter for the heavy extrusion (pieces E, K and R).

Billet used by Harper for the Ti-6-4 extrusion (pieces C and D) and the Ti-6-6-2 extrusion (pieces N and P) was obtained from Reactive Metals Inc. Material was cast as a 30-inch diameter ingot by the Consumable Electrode Vacuum Melt process, forged to approximate billet size and lathe-turned to the 6 3/4-inch diameter used. The Ti-8-1-1 billet for pieces H and J were obtained from Titanium Metals Corporation. A twenty-eight-inch CEVM billet was forged and supplied lathe-turned to 6 3/4-inch round.

Chemical composition of the material used is shown in Table I.

Extrusions from Harvey Aluminum were produced on a Loewy 3850 ton horizontal extrusion press. Extrusions from H. M. Harper were produced on a Loewy 1650 ton horizontal extrusion press, modified to provide approximately 1800 tons of pressure. Details of processing are shown in Table II.

Straightening by Harvey was performed before the annealing operation. Harper produced material was straightened by a hot stretch after the anneal. Temperatures for hot straightening at Harper were monitored by thermocouples attached to the length being straightened. To avoid warpage, parts were cooled in the stretcher with a low stress level held and automatically monitored. The two variations outlined represent the two common practices being followed in extrusion production. With proper control of straightening temperature, amount of stretch, and control of relief of strain during cooling

TABLE I CHEMICAL COMPOSITION OF TEST EXTRUSIONS

| Extruder Piece Ident. | Billet Source, Heat | Chemical Analysis in Weight Percent | | | | | | | | | | | | | | | | | | |
|-----------------------|---------------------|-------------------------------------|------|-------|-------|-------|------|---------|------|----|----|------|------|--|--|--|--|--|--|--|
| | | Al | V | O | N | C | Fe | H (PPM) | Mo | Sn | Cu | | | | | | | | | |
| T1-6-4 | | | | | | | | | | | | | | | | | | | | |
| Harvey, A,B | Harvey D 47 | 6.31 | 4.32 | 0.15 | 0.009 | 0.039 | 0.18 | 43 | | | | | | | | | | | | |
| Harvey, E | Harvey D 79 | 6.40 | 4.38 | 0.17 | 0.011 | 0.044 | 0.19 | 60 | | | | | | | | | | | | |
| Harper, C,D | Reactive 301658 | 6.6 | 4.3 | 0.165 | 0.008 | 0.02 | 0.17 | 59 | | | | | | | | | | | | |
| T1-8-1-1 | | | | | | | | | | | | | | | | | | | | |
| Harvey F,G | Harvey 3263 | 7.82 | 1.04 | 0.11 | 0.014 | 0.024 | 0.26 | 49 | 1.00 | | | | | | | | | | | |
| Harvey K | Harvey B 40 | 8.10 | 1.15 | 0.13 | 0.006 | 0.026 | 0.23 | 63 | 1.10 | | | | | | | | | | | |
| Harper H,J | Timet D-9399 | 7.9 | 1.1 | 0.080 | 0.008 | 0.023 | 0.06 | 60 | 1.0 | | | | | | | | | | | |
| T1-6-6-2 | | | | | | | | | | | | | | | | | | | | |
| Harvey L,M | Harvey B 16 | 5.75 | 5.72 | 0.17 | 0.013 | 0.097 | 0.68 | 62 | | | | 1.82 | 0.72 | | | | | | | |
| Harvey R | Harvey E 33 | 5.85 | 5.49 | 0.13 | 0.008 | 0.071 | 0.71 | 88 | | | | 2.18 | 0.72 | | | | | | | |
| Harper N,P | Reactive 292557 | 5.7 | 5.7 | 0.132 | 0.008 | 0.02 | 0.72 | 0.43 | | | | 2.1 | 0.69 | | | | | | | |

TABLE II EXTRUSION PROCESSING HISTORY

| Producer | Alloy | Section | Nominal Container Diameter | Extrusion Ratio | Billet Temperature | Runout (Approx.) | Straightening | Cleaning |
|----------|----------|---------|----------------------------|-----------------|--------------------|------------------|---|--|
| Harvey | T1-6-4 | Fig. 1 | 6" | 20.0 | 1980°F | 26'-6" | Arbor Press before anneal | Kylene descale (850°F 1 hour) Pickle (HNO ₃ -HF) |
| | | Fig. 2 | 7" | 16.9 | 1970°F | 23' | | |
| | T1-8-1-1 | Fig. 1 | 6" | 20.0 | 2085°F | 27' | Hot stretch after anneal, stretch performed at anneal temperature | Abrasive blast clean to descale Pickle (HNO ₃ -HF) |
| | | Fig. 2 | 7" | 16.9 | 2070°F | 23' | | |
| Harper | T1-6-6-2 | Fig. 1 | 6" | 20.0 | 2100°F | 27' | Hot stretch after anneal, stretch performed at anneal temperature | Abrasive blast clean to descale Pickle (HNO ₃ -HF) |
| | | Fig. 2 | 7" | 16.9 | 2010°F | 23' | | |
| | T1-6-4 | Fig. 1 | 7" | 23.8 | 2120°F | 26' | | |
| | | Fig. 1 | 7" | 23.8 | 2120°F | 26' | | |
| | T1-8-1-1 | Fig. 1 | 7" | 23.8 | 2120°F | 26' | | |
| | | Fig. 1 | 7" | 23.8 | 2120°F | 26' | | |

no significant difference appeared in end results when hot straightening after anneal was compared with the final operation being the anneal cycle.

METALLOGRAPHIC CONTROL

Two transverse sections were examined for each of the five lengths of extrusion in each of the three alloys. Specimen location was at the end inch of each piece.

In general, macrostructures exhibited end grain, with little evidence of grain flow. Those lines which occurred followed the contour of the section. Grain size appeared largest at the center or junction of the tee, and was finer in the leg areas. The thinner leg of the unequal thickness tee showed smaller grains than in heavier areas, as would be expected from the degree of work during extrusion.

Microstructures of the extrusions are considered to be characteristic of those of titanium alloys extruded above the beta transus temperature.

Typical photomicrographs and photomacrographs for Ti-6Al-4V are shown in Figure 11, for Ti-8Al-1Mo-1V in Figure 12 and for Ti-6Al-6V-2Sn in Figure 13.

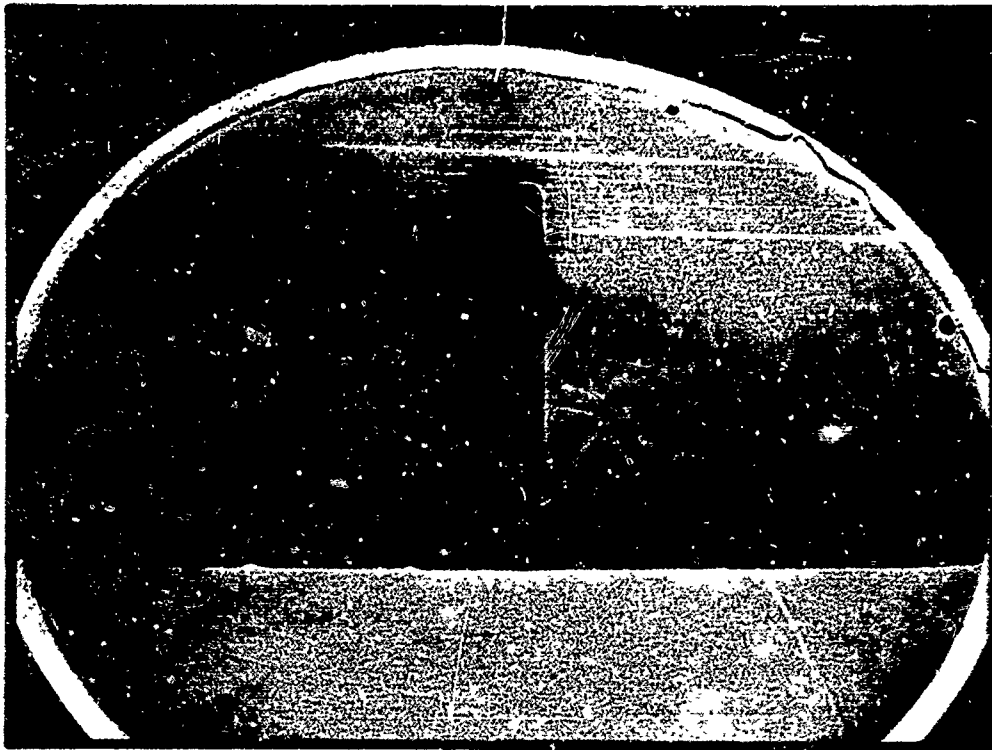

Macrostructure (1-1/2x)



Microstructure, Junction (200x)



Microstructure, Cap Tip (200x)

Figure 11. Typical Macrostructure and Microstructure of Ti-6Al-4V Extrusion

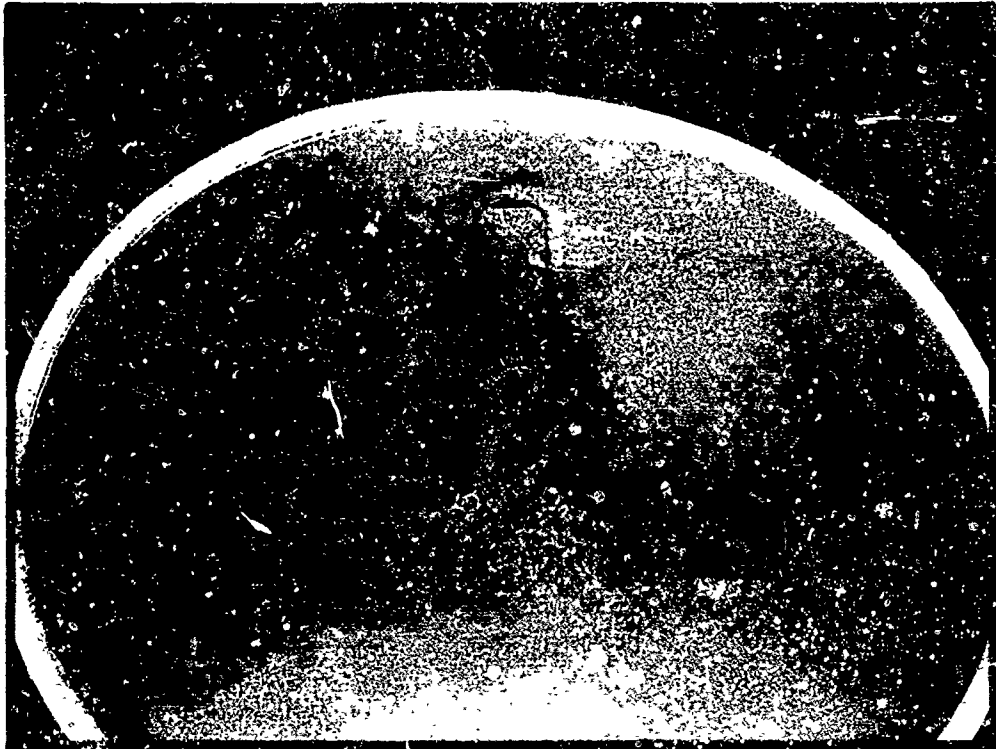

Macrostructure (1-1/2x)



Microstructure, Junction (200x)



Microstructure, Cap Tip (200x)

Figure 12. Typical Macrostructure and Microstructure of Ti-8Al-1Mo-1V Extrusion



Macrostructure (1-1/2x)



Microstructure, Junction (200x)

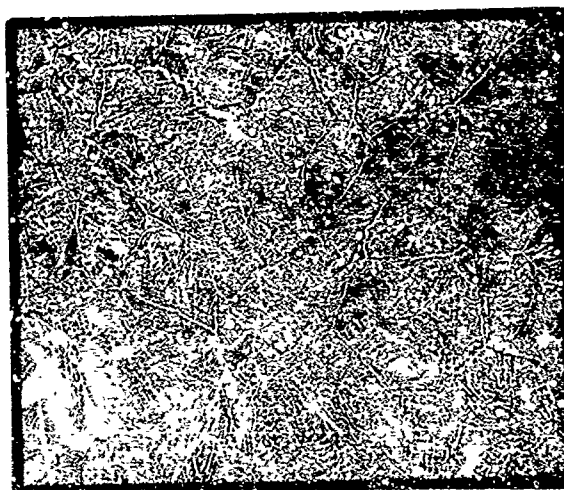

Microstructure, Cap Tip (200x)

Figure 13. Typical Macrostructure and Microstructure of Ti-6Al-6V-2Sn Extrusion

Section III

MATERIAL PROPERTY TEST PROCEDURES

TENSILE TESTS

The specimens used in the tensile tests are shown in Figures 14 and 15. The standard 1-inch gage length flat specimen was used to test the small extrusions; the standard 1-inch gage length round specimen was used to test the large extrusions. The tests were conducted in 5, 50, and 120 Kip Baldwin universal test machines, in accordance with the requirements of FED-STD-151. A strain rate of 0.005 in/in/min was used through the proportional limit of the material. Class B extensometers were used in conjunction with standard autographic readout equipment to provide partial or full length load-strain curves.

COMPRESSION TESTS

The Lockheed standard X-6720-8 specimen used in the compression tests is shown in Figure 16. The tests were conducted in 5, 50, and 120 Kip Baldwin universal test machines at a strain rate of 0.005 in/in/min through the proportional limit of the material. Class B extensometers were used in conjunction with standard autographic readout equipment to provide load-strain curves.

TENSION AND COMPRESSION MODULUS OF ELASTICITY

The tension and compression modulus of elasticity tests were conducted on the specimens shown in Figures 15 and 16 in a Research Inc. 100 Kip closed loop servo-hydraulic materials testing system. The precision strain data for modulus determination were obtained using Tuckerman optical strain gages. Each specimen was loaded in a minimum of five equal load increments to a maximum stress that was below 50 percent of the nominal yield strength of the material. A Tuckerman gage was attached to each side of the specimen, and the strain was recorded for each gage at each load increment. The strain readings were plotted on graph paper, and a straight line between the points was drawn to provide a slope value for determination of the modulus value for each gage. If the modulus values for the two gages varied less than two percent, the average of the two values was reported as the modulus of elasticity for the specimen. If the two values varied by more than two percent, the specimen was retested using the same procedure until the results obtained varied by less than two percent.

SHEAR TESTS

The specimen used in the shear tests is shown in Figure 17. Double shear type tests were conducted in an 120 Kip Baldwin universal test machine using standard clevis and tongue fixtures. The load was applied at a rate which corresponded to a head deflection rate of 0.1 inch/min; only the ultimate load was recorded.

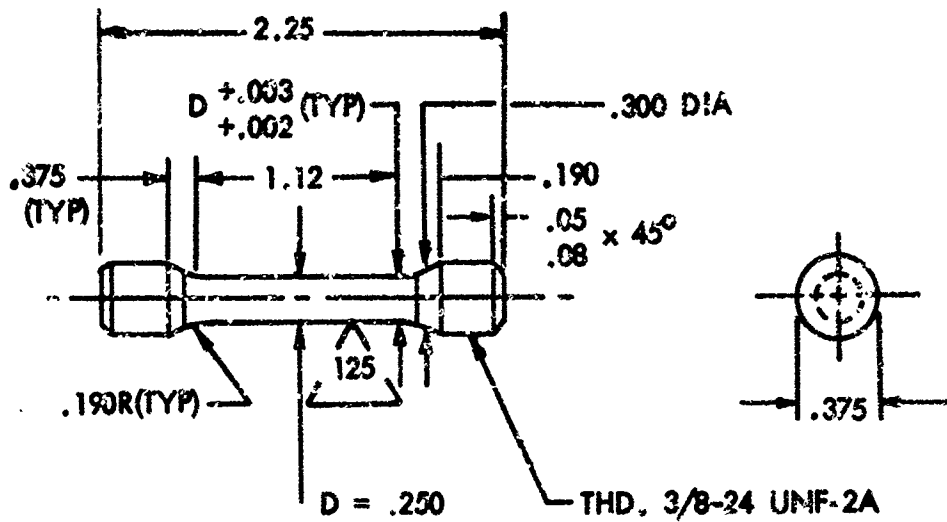

Figure 14. Round Tensile Specimen

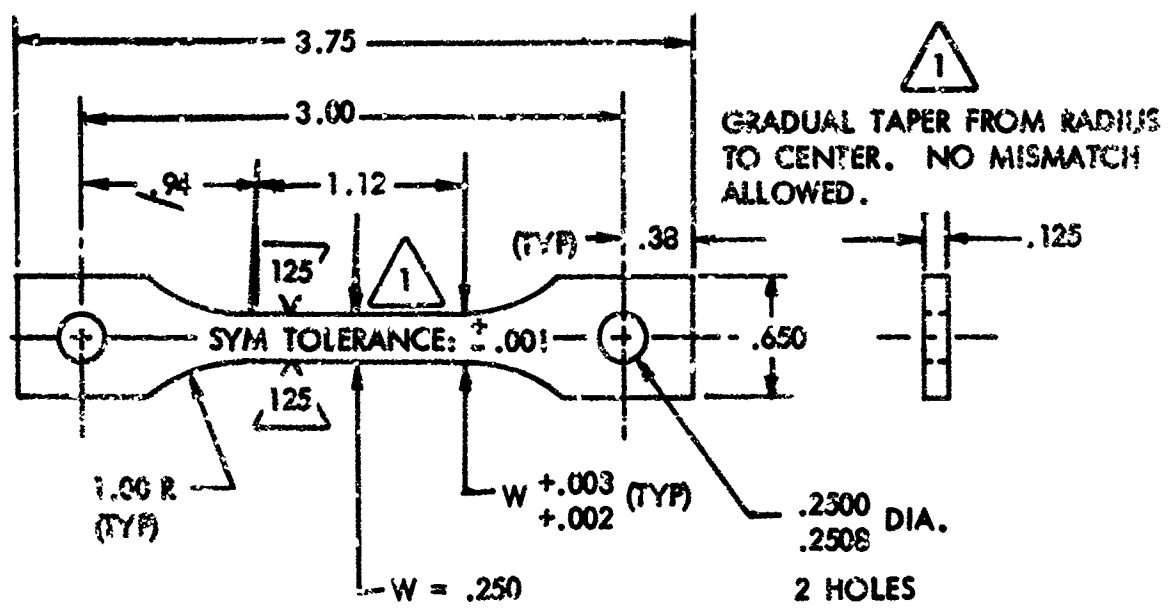

Figure 15. Flat Tensile Specimen

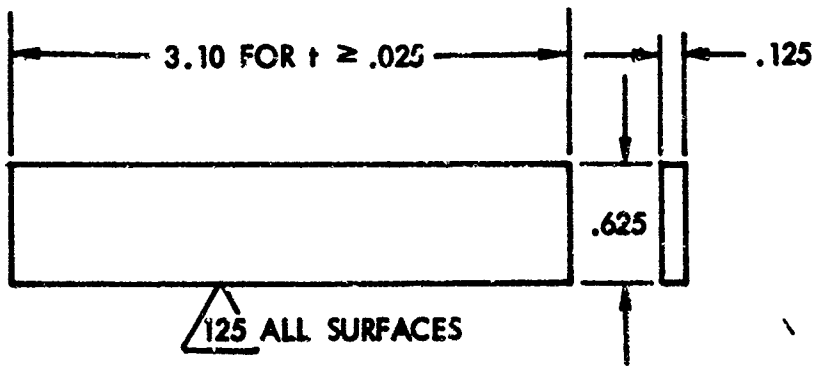

Figure 16. Compression Specimen

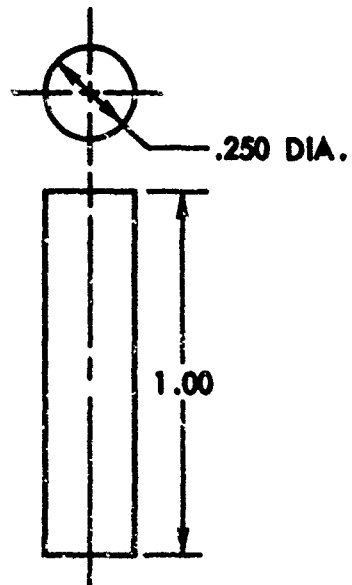

Figure 17. Shear Specimen

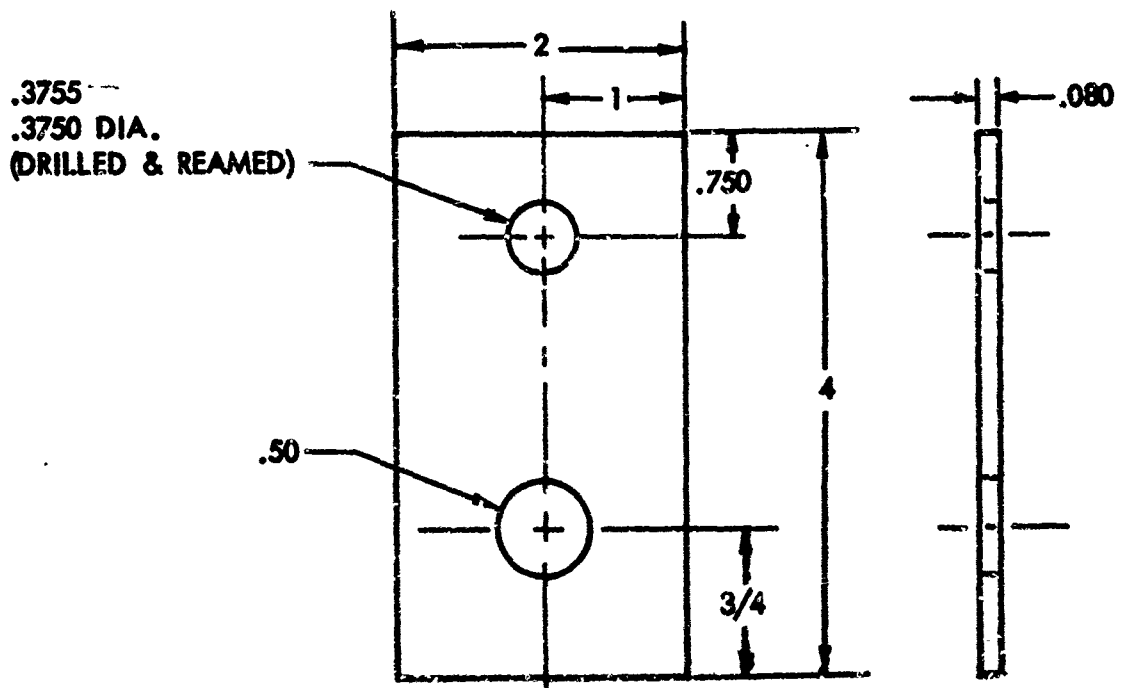

Figure 18. Bearing Specimen

Misalignment of some of the specimens in the fixtures resulted in certain failures occurring through single shear after extensive bending had taken place. The single shear values were lower than the double shear values for comparable specimens and were considered invalid. Data patterns establishing other test points were considered sufficiently significant, however, that duplicate testing was not considered to be required.

BEARING TESTS

The bearing tests ($e/D = 2$) were conducted on the specimen shown in Figure 18. The bearing hole was drilled and reamed to within one-thousandth of an inch of the diameter of the hardened steel loading pin. The tests were conducted in a 120 Kip Baldwin universal test machine at a rate corresponding to a test head movement rate of 0.008 in/min through the yield point of the material. A load-strain curve was obtained for each specimen by means of a Class B extensometer in conjunction with standard autographic readout equipment. The yield strength was calculated by using the load at which the recorded permanent deformation, using the offset method, Δ was equivalent to 2 percent of the hole diameter.

For the $e/D = 1.5$ tests, the bearing specimen was modified so that the edge distance was reduced from 0.750 to 0.562 inch. The test procedure remained the same.

TEMPERATURE EFFECT TEST PROCEDURES

The test procedures for the tension, compression, shear, and bearing tests were essentially the same for each test temperature between -110° and 800° F. The -110° F tests were conducted in a gaseous CO_2 test chamber; the elevated temperature tests were conducted in a circulating air furnace. The specimens were held at the test temperature for 20 minutes before testing. Both the test chamber and the specimen were monitored by thermocouples, and the test temperature of the specimen was maintained at the specified level $\pm 5^{\circ}$ F.

CREEP AND STRESS RUPTURE TESTS

Standard creep and stress rupture tests were conducted on the specimen shown in Figure 19 at 400, 600 and 800° F in accordance with ASTM Specification E-139. The tests were conducted in 6 or 12 Kip Satec creep machines. A thermocouple was attached to each end of the specimen gage length and a temperature-time plot was recorded throughout the test. A LVDT extensometer was used to continuously record a time-strain plot.

After initial probes, stress rupture tests were discontinued if rupture did not occur within a time of at least 100 hours. The creep tests were discontinued after 1000 hours, or in some cases after a shorter period of time if the specimens were not undergoing creep deformation.

Because of the apparent resistance of the extruded metallurgy to creep deformation, a portion of the testing was re-directed at rapid heating-rapid loading creep could be probed.

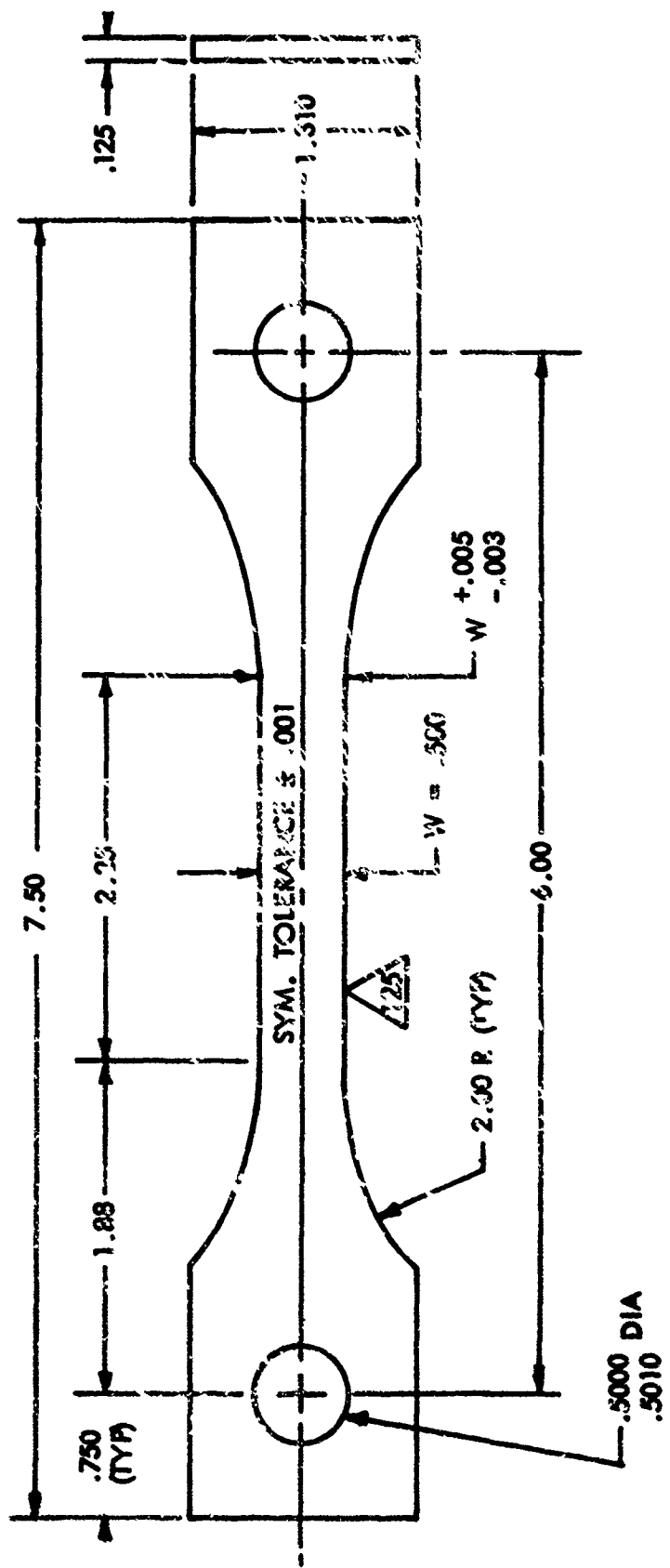

Figure 19. Creep and Stress Rupture Specimen

The short time creep tests were conducted at 600°F and 800°F on the remainder of the specimens under conditions of rapid heating. The tests were conducted in accordance with ASTM Specification E-150 using loading condition (1). Tests were conducted in a Research Incorporated 100 Kip test machine using the self-resistance method of heating. The specimen was heated to the test temperature + 10°F in 60 seconds and held at the nominal test temperature for 60 seconds prior to application of the load. The temperature was monitored by thermocouples attached to the ends of the specimen gage length.

The load was applied at a uniform rate within 5 ± 2 seconds from the time of start of loading. Strain measurements were obtained using a Class B extensometer. Strain was recorded from the start of heating of the specimen until the specimen was unloaded.

CHARPY IMPACT TESTS

The standard Charpy V-notched specimen shown in Figure 20 was used to test the large extrusions; the modified specimen shown in Figure 21 was used to test the small extrusions. The tests were conducted at -110, 72, 110, and 400°F in accordance with Method 221.1 of Federal Test Method Standard No. 151.

PLANE-STRAIN FRACTURE TOUGHNESS

Edge cracked, four point loaded constant moment bend specimens were used for the fracture toughness tests. The 1-inch wide specimen shown in Figure 22 was used to test the large extrusions; the 1/2-inch wide specimen shown in Figure 23 was used to test the small extrusions. A fatigue crack was generated at the base of the machined vee notch by repeated tension-tension loading in four point bending. The ratio of minimum to maximum load was 0.1; the maximum nominal bending stress level used was less than 50 percent of the tensile yield strength of the material. The total crack depth ("vee" notch plus fatigue crack) was nominally 20 percent of the specimen width.

The pre-cracked specimens were loaded to failure in the 100 Kip test machine at a rate equivalent to a strain rate of 0.005 in/in/min. A model PD-1M deflectometer was used to obtain an autographic curve of load vs. test head movement. The "pop-in" load (point of initial crack instability) was obtained from the curve, and the crack depth was measured on the specimen fracture surface. These values were used in the following equation to obtain the plane-strain fracture toughness value K_{Ic} (the critical stress-intensity factor associated with initiation of unstable plane-strain fracturing). The units for the K_{Ic} value are Ksi $\sqrt{\text{in}}$.

$$K_{Ic}^2 = \frac{P^2 L^2}{(1-\mu^2) B^2 W^3} \left[34.7 \left(\frac{a}{W}\right) - 55.2 \left(\frac{a}{W}\right)^2 + 196 \left(\frac{a}{W}\right)^3 \right]$$

where:

P = load at crack instability, (Kips)

L = moment arm length (Inches) (3 in. for the 1-inch wide specimen and 3/2 in. for the 1/2-inch wide specimen)

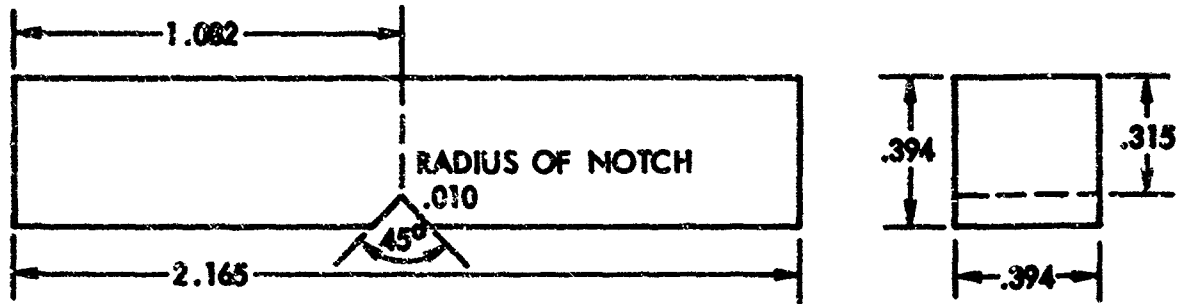

Figure 20. Charpy Specimen, Thick Extrusion

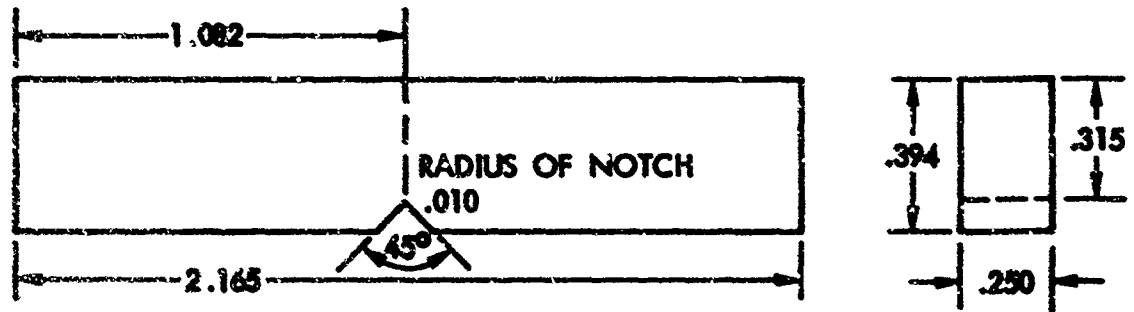

Figure 21. Charpy Specimen, Thin Extrusion

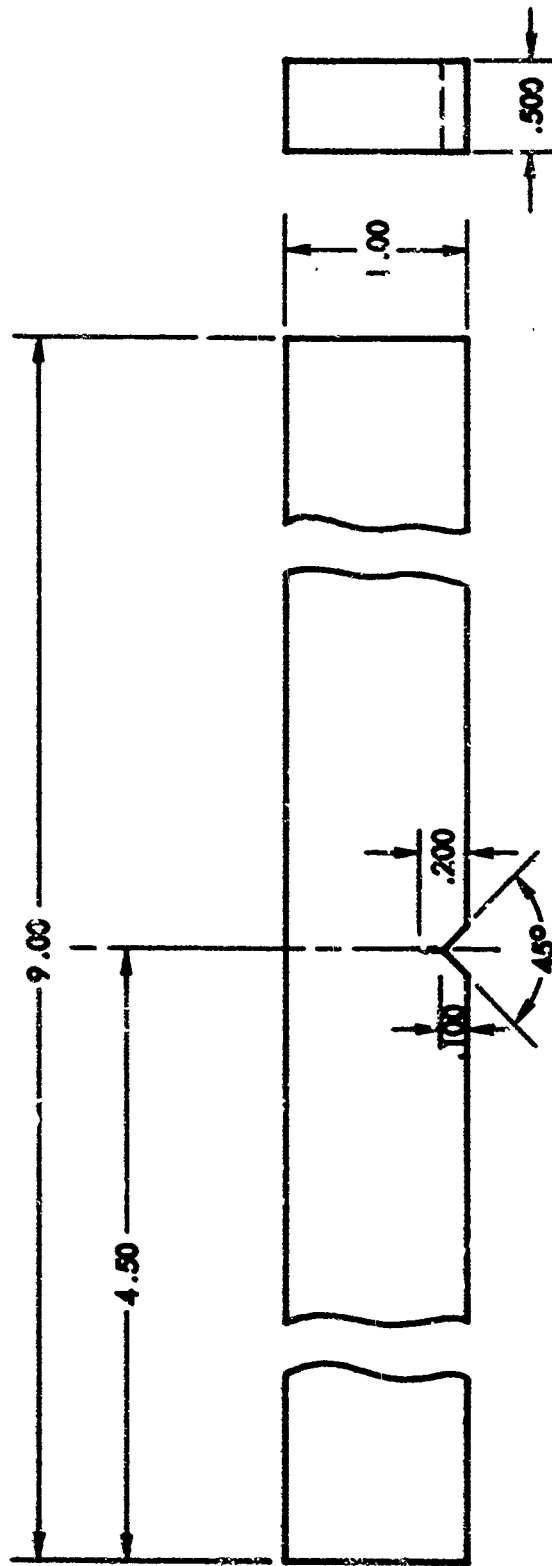

Figure 22. Fatigue Cracked Bend Specimen, Thick Extrusion

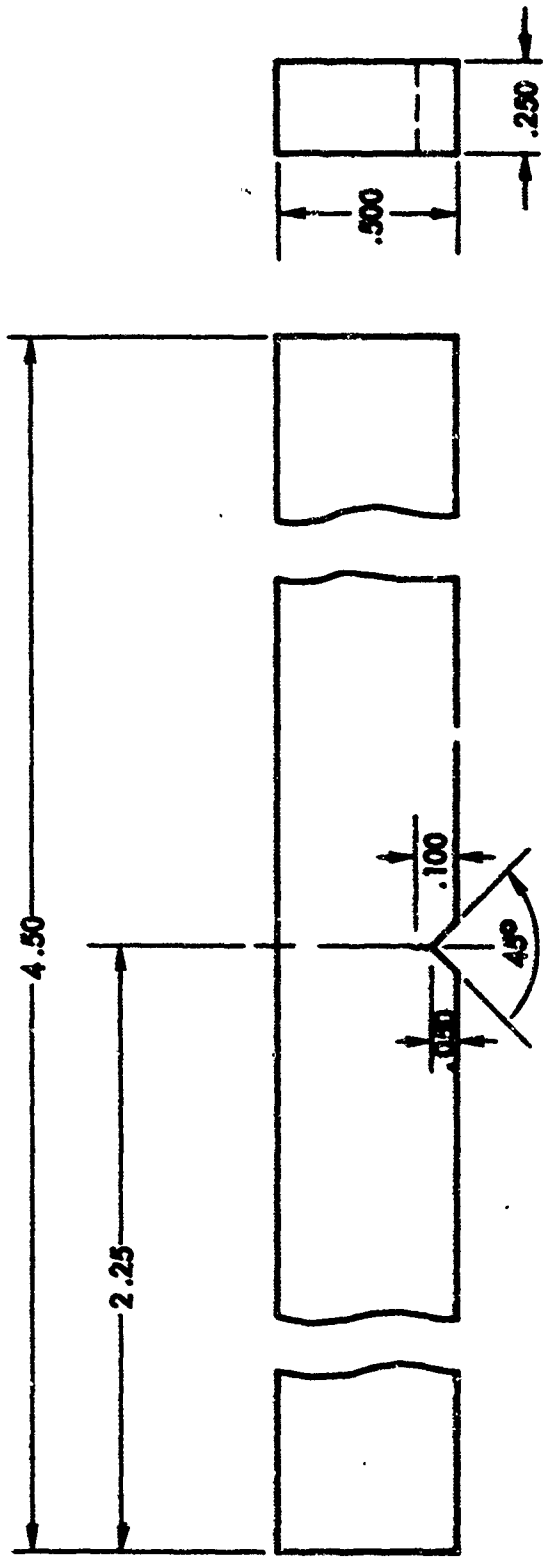

Figure 23. Fatigue Cracked Bend Specimen; Thin Extension

B = Specimen thickness (Inches)

W = Specimen width (Inches)

a = Crack depth in the center of the specimen thickness (Inches)
(notch plus fatigue crack)

μ = Poisson's ratio = 0.3

The -110°F fracture toughness tests were conducted in a CO_2 gas chamber. The specimens were held at the test temperature for 30 minutes before testing. Both the test chamber and the specimen were monitored by thermocouples, and the test temperature of the specimen was maintained at $-110 \pm 5^{\circ}\text{F}$. The area of the crack was covered with plastic tape to prevent contamination by moisture.

DELAYED FAILURE TESTS

The delayed failure tests were conducted on the pre-cracked fracture toughness specimens previously described. A transparent plastic strip was taped to each side of the specimen in the area of the crack. A sodium chloride solution (3 1/2 percent by weight sodium chloride in distilled water) was added to the container prior to load application so that the entire crack was covered. The top of the container was left open to the air; if evaporation occurred the container was refilled with distilled water. The level of the solution was kept nearly constant throughout the tests.

The specimens were stressed at a rate equivalent to a strain rate of 0.005 in/in/min to a predetermined sustained load level which was fifty percent of the ultimate load for the fracture toughness specimens from the same test group. The 1/2-inch wide specimens were tested in a Research Incorporated 100 Kip test machine; the 1-inch wide specimens were tested in Lockheed-designed hydraulic test machines. If a test specimen did not fail during a specified time at the sustained load level, it was loaded to failure. Additional specimens from the same test group were loaded to higher (or lower) load levels until a threshold level at which failure did not occur was determined.

The sustained load level for each specimen is substituted for "P" in the equation for " K_{Ic} " to obtain the sustained load plane-strain stress intensity value which is designated as K_{Ii} and which also has units of $\text{Ksi} \sqrt{\text{in}}$.

At least one specimen from each test group was held at the threshold level for 100 hours. It should be pointed out that because of the scatter in the test results, the threshold level is defined as the highest K_{Ii} level at which a specimen held, and below which no specimen from the test group failed. There are usually specimens in any test group which do not fail at levels above the threshold K_{Ii} value, but additional specimens from the same group will fail at the same level. The range of the scatter in the K_{Ii} values for titanium alloy specimens is often as much as 10 $\text{Ksi} \sqrt{\text{in}}$ units.

S-N FATIGUE TESTS

The smooth ($K_t = 1$) and center notched ($K_t = 2.7$) fatigue specimens that were used are shown in Figures 24 and 25. The tests were conducted in Lockheed

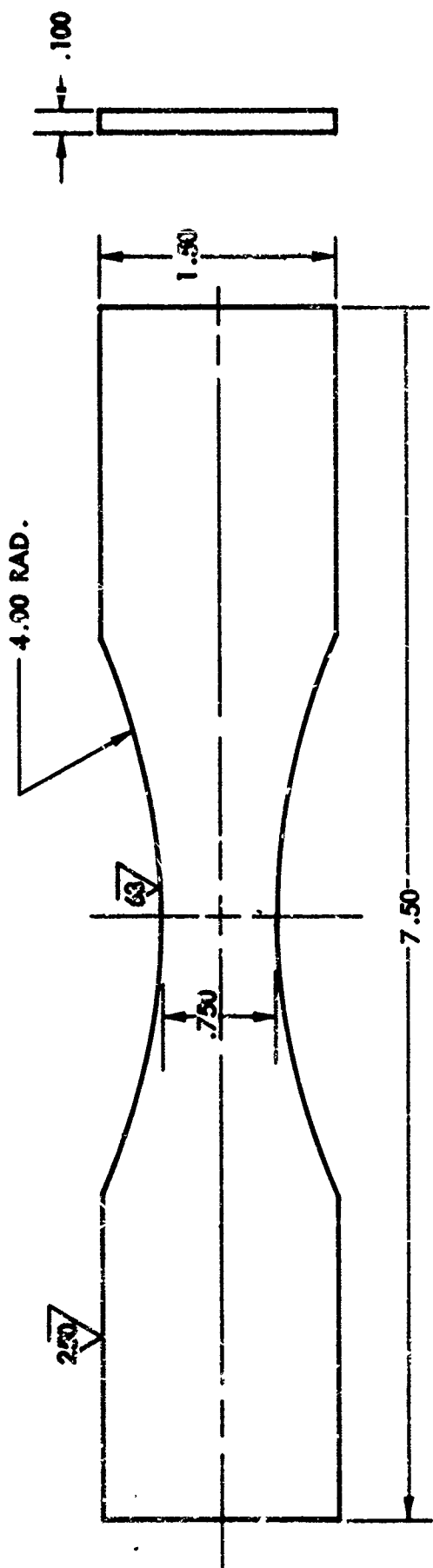

$K_T = 1.0$

Figure 24. Smooth Fatigue Specimen

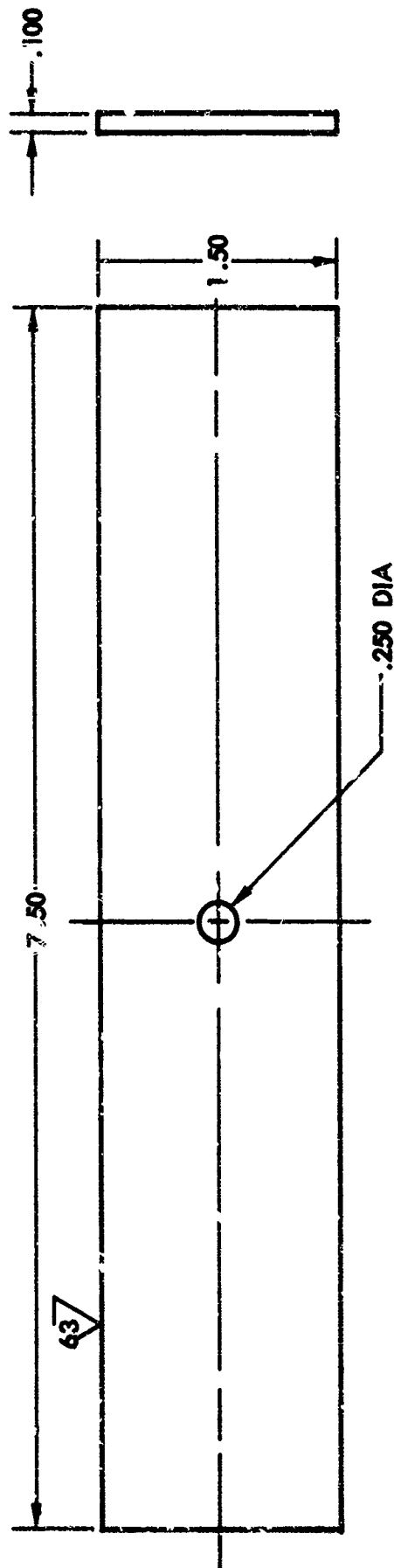

$K_T = 2.7$

Figure 25. Notched Fatigue Specimen

designed constant amplitude fatigue test machines at stress ratios (A) of ∞ , 0.98 and 0.4. The specimens were tested until failure occurred or until 10^7 cycles had elapsed.

Elevated temperature fatigue tests were conducted in radiant heat furnaces. The specimen test temperature was monitored by a thermocouple and was maintained at the desired level $\pm 5^\circ\text{F}$. The specimens were held at the desired level for 10 minutes before testing. Tests were conducted at 1800 cycles per minute.

Section IV

DISCUSSION OF RESULTS

BASIS FOR EVALUATION

It is considered that this program has developed either two or three data points to be used in conjunction with material from other sources to establish MIL-HDBK-5 values for titanium extrusions (the number of data points depends on the mixture of tests and material source).

Reliability and uniformity of properties within the individual piece were established by room temperature testing. Having obtained this verification, vendor data can be used with confidence to establish room temperature specifications or A and B design values for longitudinal tensile properties. Transverse property data and compressive property data are available in depth from extrusion producers so that statistical values may be obtained by direct methods, or by indirect methods with a broad statistical base.

Effect of temperature on properties, and properties for which design values are normally obtained by derivation have been analyzed to determine that material performance was consistent between vendor, heat, and size. These relationships, in turn, were reviewed in relation to published data on other product forms to establish if the limited information appeared to be part of the same statistical data population, or if significant differences appeared.

UNIFORMITY OF PROPERTIES

Properties throughout all pieces in each of the three alloys tested were considered to be uniform, well within the variations normally expected from extruded material. In the combination of length, test direction, and cross section location within one piece the indicated variation in Ti-6Al-4V tensile ultimate strength (TUS) was under 4%, and variation in TYS less than 5%. In alloys Ti-6Al-6V-2Sn and Ti-8Al-1Mo-1V, the variation within any one piece was under 5% in TUS and under 8% in TYS. Variation in properties between pieces, with location in cross section grain direction, and length is shown in Tables III, IV, and V, and in Figures 26, 27, and 28.

No effect of extrusion direction is apparent from these and other tests. Section location has a random effect, and does not appear to follow a pattern on annealed material. Processing controls to avoid possible degradation of properties because of work effects would allow design in the transverse direction to parallel design in the longitudinal direction. The same principle could also apply in control tests.

TABLE III Ti6Al-4V EXTRUSIONS, VARIATION IN PROPERTIES WITH CROSS SECTION LOCATION, POSITION IN LENGTH, AND PIECE

| Piece No. | Cross Section Location | Ultimate Tensile Strength (ksi) | | | Tensile Yield Strength (0.2% El) | | | Elongation % | | | Compressive Yield Strength (0.2% El) | | |
|--------------|------------------------|---------------------------------|--------|------|----------------------------------|--------|------|--------------|--------|------|--------------------------------------|--------|------|
| | | Front | Center | Rear | Front | Center | Rear | Front | Center | Rear | Front | Center | Rear |
| A (Thin) | Cap - L | 142 | 144 | 145 | 125 | 117 | 130 | 13 | 16 | 14 | RT | 139 | 139 |
| | Junction - L | 141 | 142 | RT | 125 | 126 | RT | 17 | 15 | RT | 137 | 139 | 138 |
| | Cap - L | 142 | | 141 | 126 | | 128 | 14 | | 12 | 139 | | 139 |
| | Stem - L | 141 | 141 | 142 | 128 | 124 | 128 | 15 | 15 | 14 | 137 | 137 | 137 |
| | Cap - T | 142 | 143 | 142 | 127 | 127 | 127 | 14 | 12 | 14 | 139 | 140 | 138 |
| B (Thin) | Cap - L | 140 | | | 125 | | | 14 | | | | | |
| | Junction - L | 140 | | | 123 | | | 12 | | | | | |
| | Cap - L | 143 | | | 126 | | | 17 | | | | | |
| | Stem - L | 141 | | | 124 | | | 16 | | | | | |
| | Cap - T | 143 | | 142 | 127 | | 126 | 14 | | 14 | | | |
| C (Thin) | Cap - L | 147 | 145 | 143 | 130 | 135 | 128 | 14 | 13 | 14 | 142 | 142 | RT |
| | Junction - L | 143 | 144 | 146 | 125 | 128 | 129 | 16 | 15 | 14 | 140 | 142 | 140 |
| | Cap - L | 146 | | 146 | 129 | | 131 | 15 | | 15 | 142 | | 141 |
| | Stem - L | 143 | 144 | 144 | 127 | 128 | 130 | 18 | 16 | 16 | 142 | 142 | 141 |
| | Cap - T | 146 | 146 | 146 | 130 | 130 | 128 | 14 | 15 | 14 | 145 | 144 | 144 |
| D (Thin) | Cap - L | 146 | | | 132 | | | 16 | | | | | |
| | Junction - L | 143 | | | 127 | | | 16 | | | | | |
| | Cap - L | 145 | | | 130 | | | 16 | | | | | |
| | Stem - L | 149 | | | 136 | | | 14 | | | | | |
| | Cap - T | 146 | | 147 | 130 | | 130 | 14 | | 15 | | | |
| E (Heavy) | Cap - L | 143 | | 144 | 129 | | 130 | 14 | | 14 | | | |
| | Junction - L | 140 | | 141 | 125 | | 127 | 14 | | 14 | | | |
| | Stem - L | 141 | | 142 | 126 | | 128 | 14 | | 14 | | | |
| | Cap - T | 143 | | 144 | 132 | | 130 | 14 | | 14 | | | |

TABLE IV TH3AL-1MO-1V EXTRUSIONS, VARIATION IN PROPERTIES WITH CROSS SECTION, POSITION IN LENGTH, AND PIECE

| Piece No. | Cross Section Location | Ultimate Tensile Strength (Ksi) | | | Tensile Yield Strength (0.2%) Ksi | | | Elongation % | | | Compressive Yield Strength (0.2%) Ksi | | |
|--------------|------------------------|---------------------------------|--------|------|-----------------------------------|--------|------|--------------|--------|------|---------------------------------------|--------|------|
| | | Front | Center | Rear | Front | Center | Rear | Front | Center | Rear | Front | Center | Rear |
| F (Thin) | Cap - L | 138 | 141 | 144 | 125 | 125 | 129 | 13 | 15 | 15 | 137 | 137 | 140 |
| | Junction - L | 135 | 135 | 134 | 121 | 121 | 121 | 16 | 18 | 18 | 135 | 135 | 131 |
| | Cap - S | 141 | | 141 | 126 | | 126 | 13 | | 15 | 139 | | |
| | Stem - L | 138 | 137 | 141 | 123 | 121 | 127 | 14 | 15 | 15 | 134 | 136 | 138 |
| G (Thin) | Cap - T | 138 | 137 | 137 | 124 | 122 | 121 | 14 | 15 | 15 | 139 | 138 | 139 |
| | Cap - L | 134 | | | 118 | | | 21 | | | | | |
| | Junction - L | 144 | | | 127 | | | 16 | | | | | |
| | Cap - L | 143 | | | 124 | | | 19 | | | | | |
| H (Thin) | Stem - L | 139 | | | 122 | | | 19 | | | | | |
| | Cap - T | 137 | | | 120 | | | 17 | | 15 | | | |
| | Cap - L | 134 | 134 | 134 | 118 | 119 | 120 | 15 | 17 | 16 | 132 | 128 | 130 |
| | Junction - L | 129 | 131 | 131 | 114 | 116 | 116 | 18 | 16 | 17 | 129 | 131 | 128 |
| J (Thin) | Cap - L | 136 | | | 122 | | | 18 | | 16 | 133 | | |
| | Stem - L | 134 | 134 | 132 | 121 | 120 | 118 | 17 | 16 | 16 | 131 | 132 | 132 |
| | Cap - T | 133 | 132 | 132 | 118 | 117 | 117 | 14 | 17 | 15 | 135 | 132 | 133 |
| | Cap - L | 136 | | | 122 | | | 18 | | | | | |
| K (Heavy) | Junction - L | 133 | | | 119 | | | 16 | | | | | |
| | Cap - L | 134 | | | 119 | | | 13 | | | | | |
| | Stem - L | 135 | | | 121 | | | 18 | | | | | |
| | Cap - T | 135 | | | 120 | | 117 | 15 | | 16 | | | |
| K (Heavy) | Cap - L | 130 | | | 126 | | 126 | 12 | | 15 | | | |
| | Junction - L | 132 | | | 119 | | 121 | 14 | | 15 | | | |
| | Stem - L | 134 | | | 122 | | 120 | 15 | | 15 | | | |
| | Cap - T | 136 | | | 123 | | 125 | 14 | | 15 | | | |

TABLE V T16AL-6V-2Sn EXTRUSIONS, VARIATION IN PROPERTIES WITH CROSS SECTION LOCATION, POSITION IN LENGTH, AND PIECE

| Piece No. | Cross Section Location | Ultimate Tensile Strength (Ksi) | | | Yanale Yield Strength (0.2%) Ksi | | | Elongation % | | | Compressive Yield Strength (0.2%) Ksi | | |
|--------------|------------------------|---------------------------------|--------|------|----------------------------------|--------|------|--------------|--------|------|---------------------------------------|--------|------|
| | | Front | Center | Rear | Front | Center | Rear | Front | Center | Rear | Front | Center | Rear |
| L (Thin) | Cap - 1 | 157 | 158 | 159 | 140 | 139 | 142 | 15 | 15 | 13 | 154 | 156 | 156 |
| | Junction - 1 | 154 | 157 | 158 | 138 | 132 | 140 | 14 | 14 | 14 | 154 | 152 | 155 |
| | Cap - 1 | 157 | | 159 | 140 | | 143 | 15 | 15 | 13 | 154 | | 156 |
| | Stem - 1 | 164 | 156 | 158 | 144 | 87 | 141 | 15 | 15 | 14 | 153 | 154 | 156 |
| | Cap - 2 | 155 | 160 | 159 | 140 | 142 | 144 | 12 | 14 | 13 | 159 | 157 | 159 |
| M (Thin) | Cap - 1 | 160 | | | 140 | | | 16 | 16 | | | | |
| | Junction - 1 | 158 | | | 138 | | | 16 | 16 | | | | |
| | Cap - 1 | 154 | | | 136 | | | 25 | 25 | | | | |
| | Stem - 1 | 157 | | | 137 | | | 17 | 17 | | | | |
| | Cap - 2 | 159 | | 160 | 140 | | 143 | 15 | 15 | 14 | | | |
| N (Thin) | Cap - 1 | 153 | 146 | 148 | 136 | 132 | 134 | 15 | 15 | 15 | 147 | 143 | 149 |
| | Junction - 1 | 147 | 143 | 145 | 134 | 131 | 132 | 16 | 16 | 17 | 148 | 147 | 146 |
| | Cap - 1 | 147 | | | 133 | | 135 | 18 | 18 | 16 | 150 | | 148 |
| | Stem - 1 | 150 | 146 | 145 | 135 | 133 | 132 | 17 | 18 | 17 | 148 | 149 | 148 |
| | Cap - 2 | 152 | 151 | 150 | 137 | 135 | 135 | 16 | 16 | 15 | 153 | 151 | 149 |
| P (Thin) | Cap - 1 | 145 | | | 134 | | | 20 | 20 | | | | |
| | Junction - 1 | 142 | | | 131 | | | 21 | 21 | | | | |
| | Cap - 1 | 146 | | | 135 | | | 18 | 18 | | | | |
| | Stem - 1 | 147 | | | 136 | | | 19 | 19 | | | | |
| | Cap - 2 | 148 | | 150 | 134 | | 135 | 18 | 18 | 17 | | | |
| R (Heavy) | Cap - 1 | 157 | | 156 | 142 | | 140 | 12 | 12 | 13 | | | |
| | Junction - 1 | 156 | | 154 | 136 | | 146 | 13 | 13 | 15 | | | |
| | Stem - 1 | 154 | | 153 | 137 | | 137 | 15 | 15 | 14 | | | |
| | Cap - 2 | 161 | | 161 | 144 | | 147 | 13 | 13 | 12 | | | |

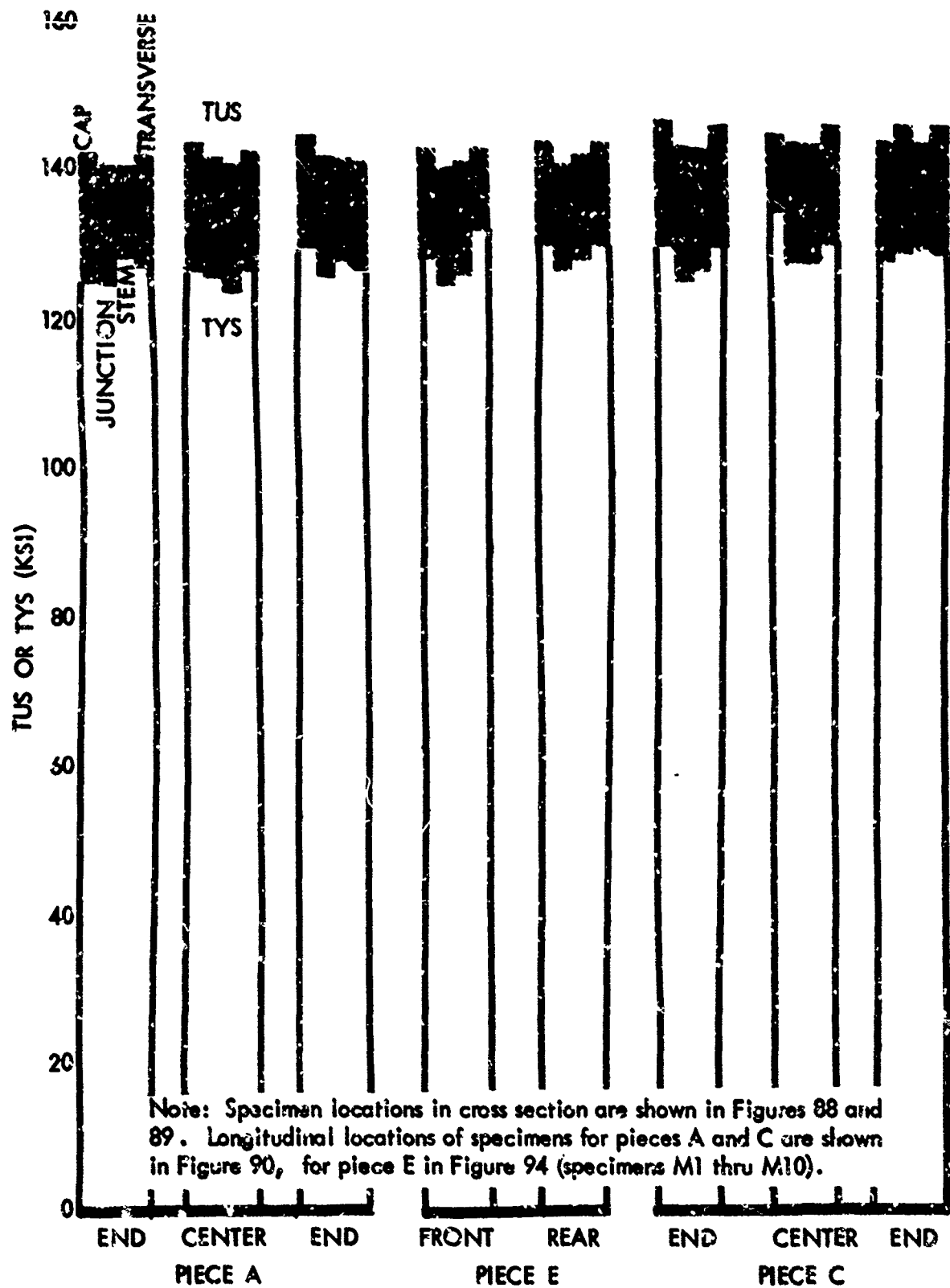

Figure 26. Comparison of Variation in TUS and TYS with Location in Cross Section in Length and Between Vendors, Sections, and Heat TI-6Al-4V Extrusions

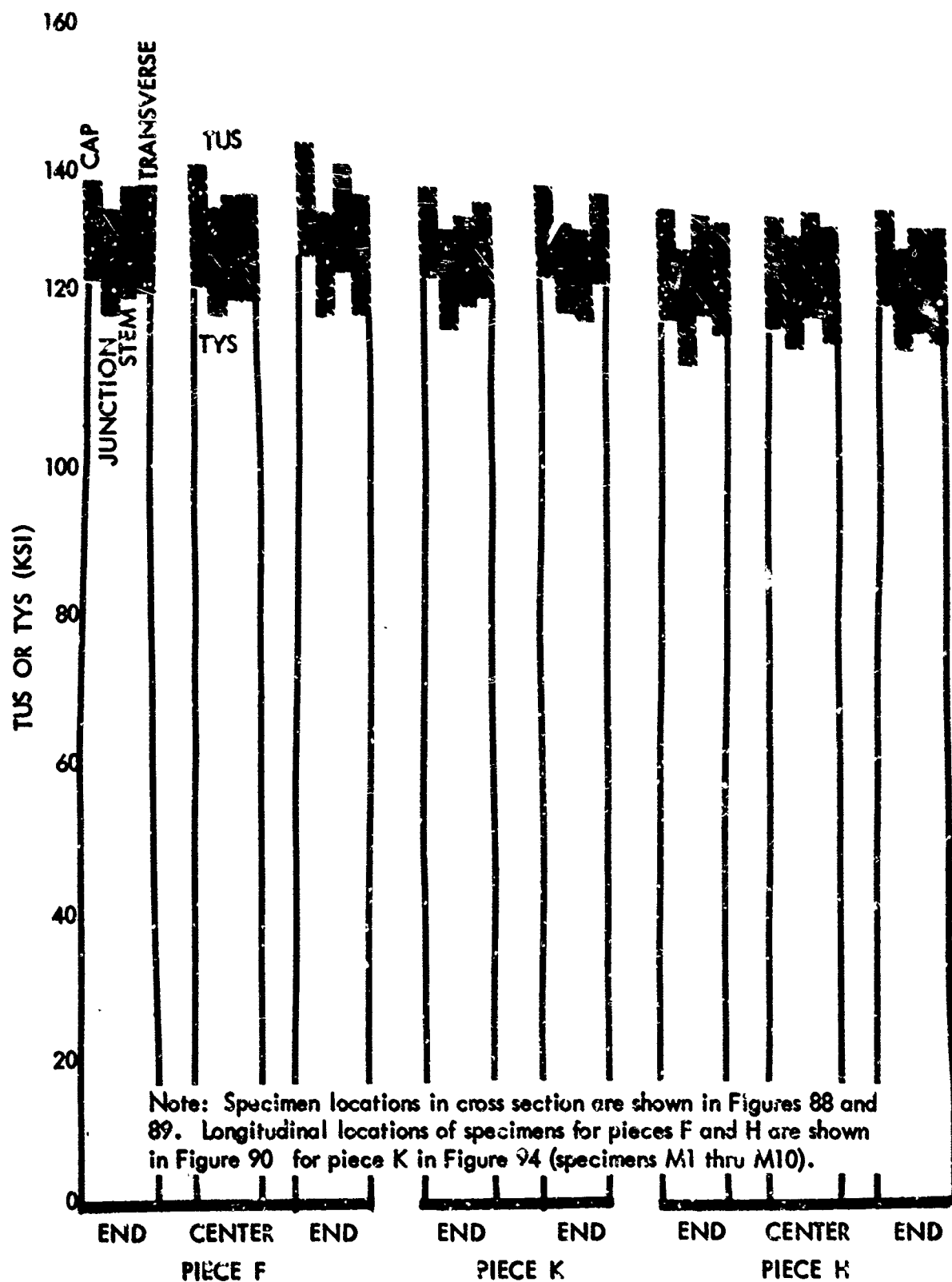

Figure 27. Comparison of Variation in TUS and TYS with Location in Cross Section, in Length and Between Vendors, Section and Heat Ti-8Al-1Mo-1V Extrusions

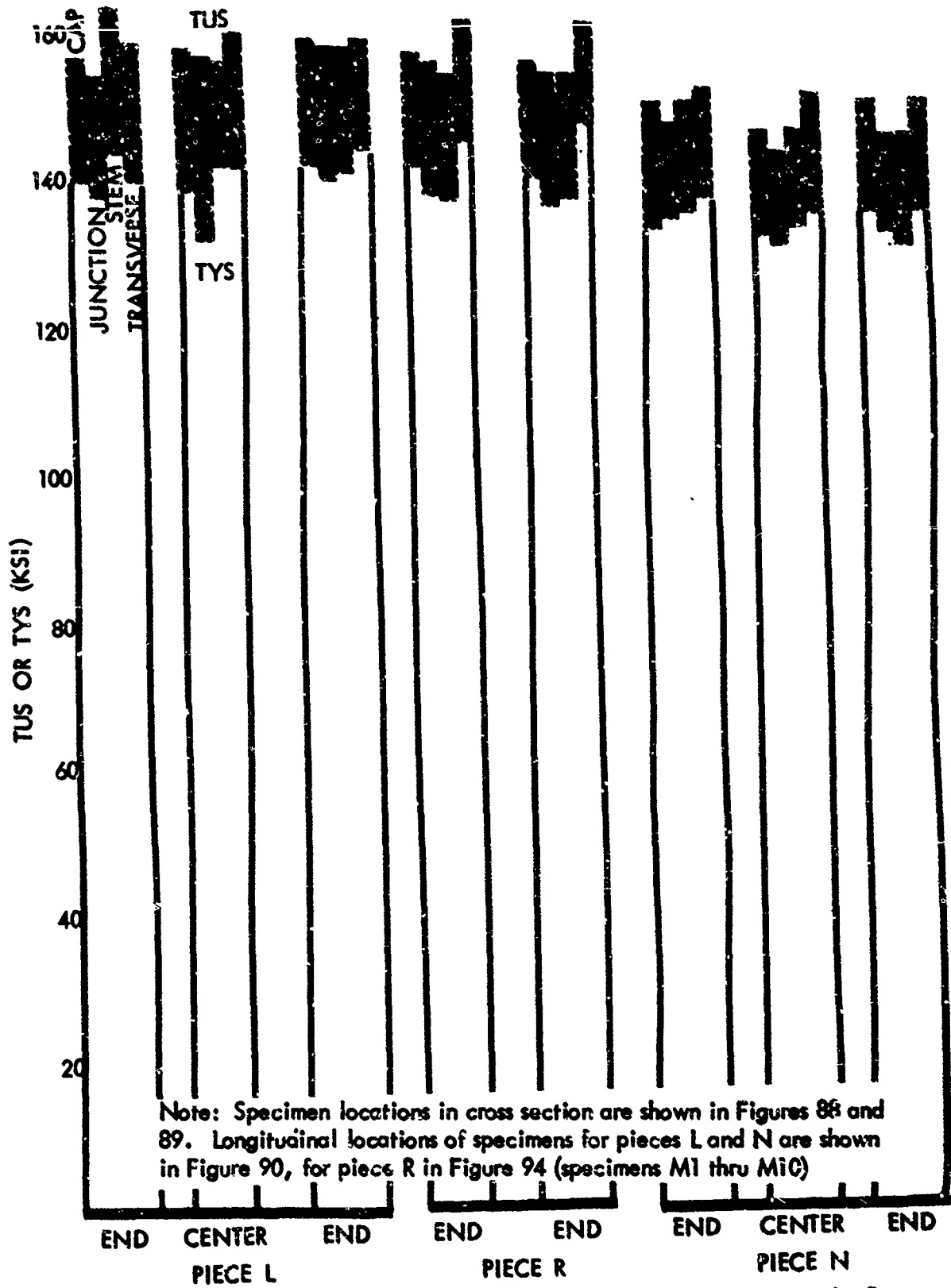

Figure 28. Comparison of Variation in TUS and TYS with Location in Cross Section, in Length, and Between Vendors, Sections and Heat Ti-6Al-6V-2Sn Extrusions

RELATIONSHIPS BETWEEN VENDORS

Sufficient data points do not exist within this program to establish relationships between vendors, except as related to a single test point only. The relation - and property scatter - between vendors should be determined from vendor accumulated property data. From the limited points, comments are as follows:

Properties of the Ti-6Al-4V extrusions supplied by the two vendors were, as shown in Figure 26, quite close. Total spread between values was less than 10%. The percentage relation on temperature effects and on derived properties such as shear and bearing appeared consistent. Relation of test data to a normal mill property distribution may be obtained by comparison with Figure 29.

Ti-6Al-6V-2Sn extrusions appeared to show a slightly greater margin of differences between vendors, possibly based on production background in the alloy. Property relationships to room temperature properties were consistent. General relationships are shown in Figure 28. Typical distribution of vendor tests for TUS is shown in Figure 30.

Ti-8Al-1Mo-1V showed greater differences than the other alloys. The discrepancy did not appear at room temperature, but both sub-zero and elevated temperatures tests seemed to indicate a change in temperature effect. Room temperature relationships are shown in Figure 27. Figure 31 shows a typical distribution of TUS test results based on vendor data.

The yield strengths shown for pieces H and J (Ti-8Al-1Mo-1V) and for pieces N and P (Ti-6Al-6V-2Sn) are lower than those shown for the alloys in Section V. The values shown as design minimums are at present consistently being achieved by one vendor as shown by Figures 30 and 31, and are presently being used in design.

MODULUS OF ELASTICITY

Precision modulus determination showed typical tensile modulus of elasticity at room temperature values as follows:

| | |
|---------------|------------------------|
| Ti-8Al-1Mo-1V | 17.6×10^6 psi |
| Ti-6Al-4V | 16.9×10^6 psi |
| Ti-6Al-6V-2Sn | 16.1×10^6 psi |

Values for the Ti-8Al-1Mo-1V agree with MIL-HDBK-5 values for other product forms of this alloy, the other two alloys have indicated modulus values higher than those shown for other product forms in MIL-HDBK-5. The relationship between alloys is in accordance with the expected pattern.

TEMPERATURE EFFECTS ON TENSILE AND COMPRESSIVE PROPERTIES

The effect of temperature on tensile properties of the three alloys is shown in Figures 5 and 6, and effect on compression yield strength in Figure 7. Temperature effect data has been plotted to show effect as percent of the room temperature property value and is presented in Section V.

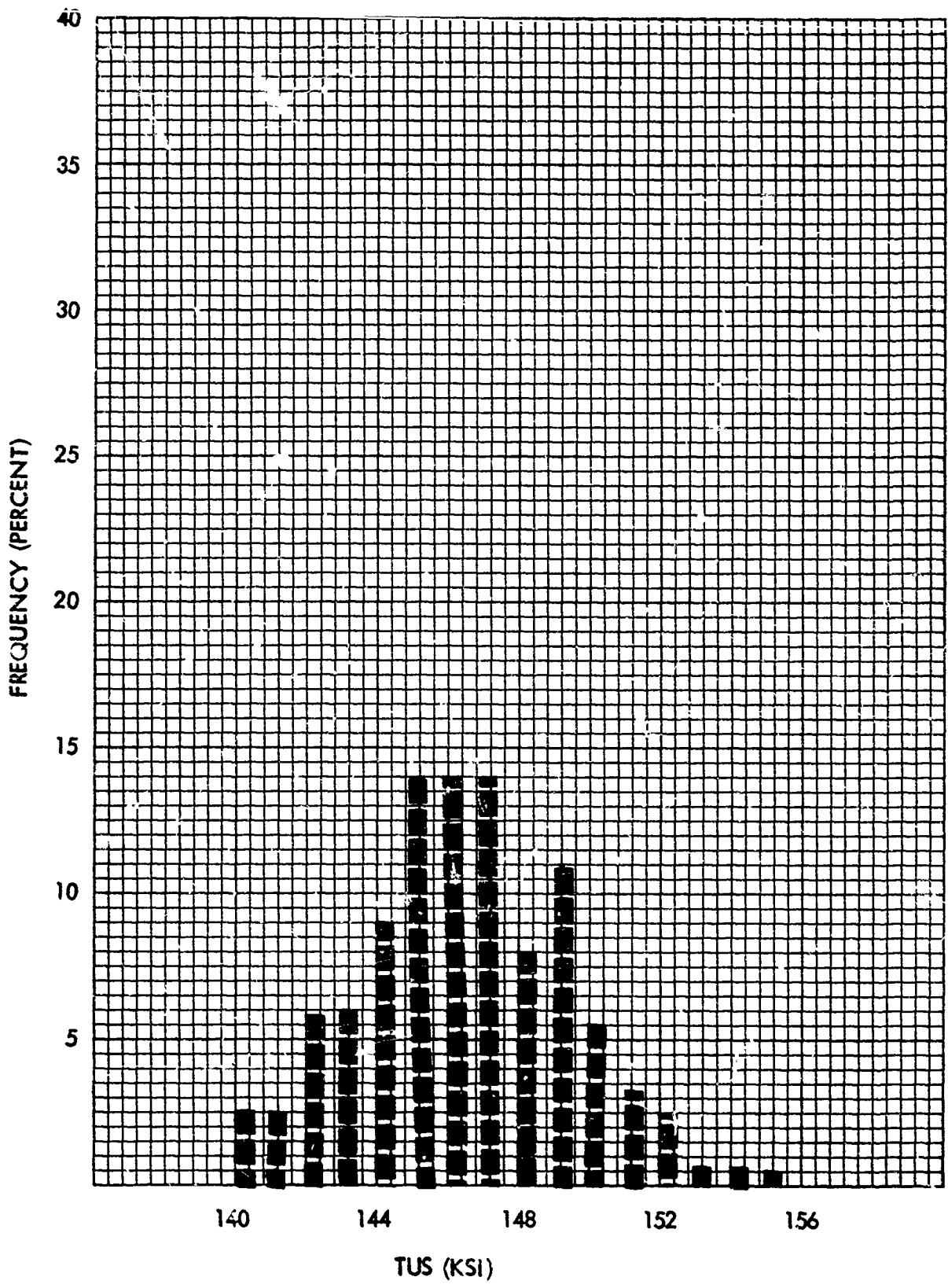

Figure 29. Typical Distribution of Test Results Annealed Ti-6Al-4V Extrusions (170 Tests)

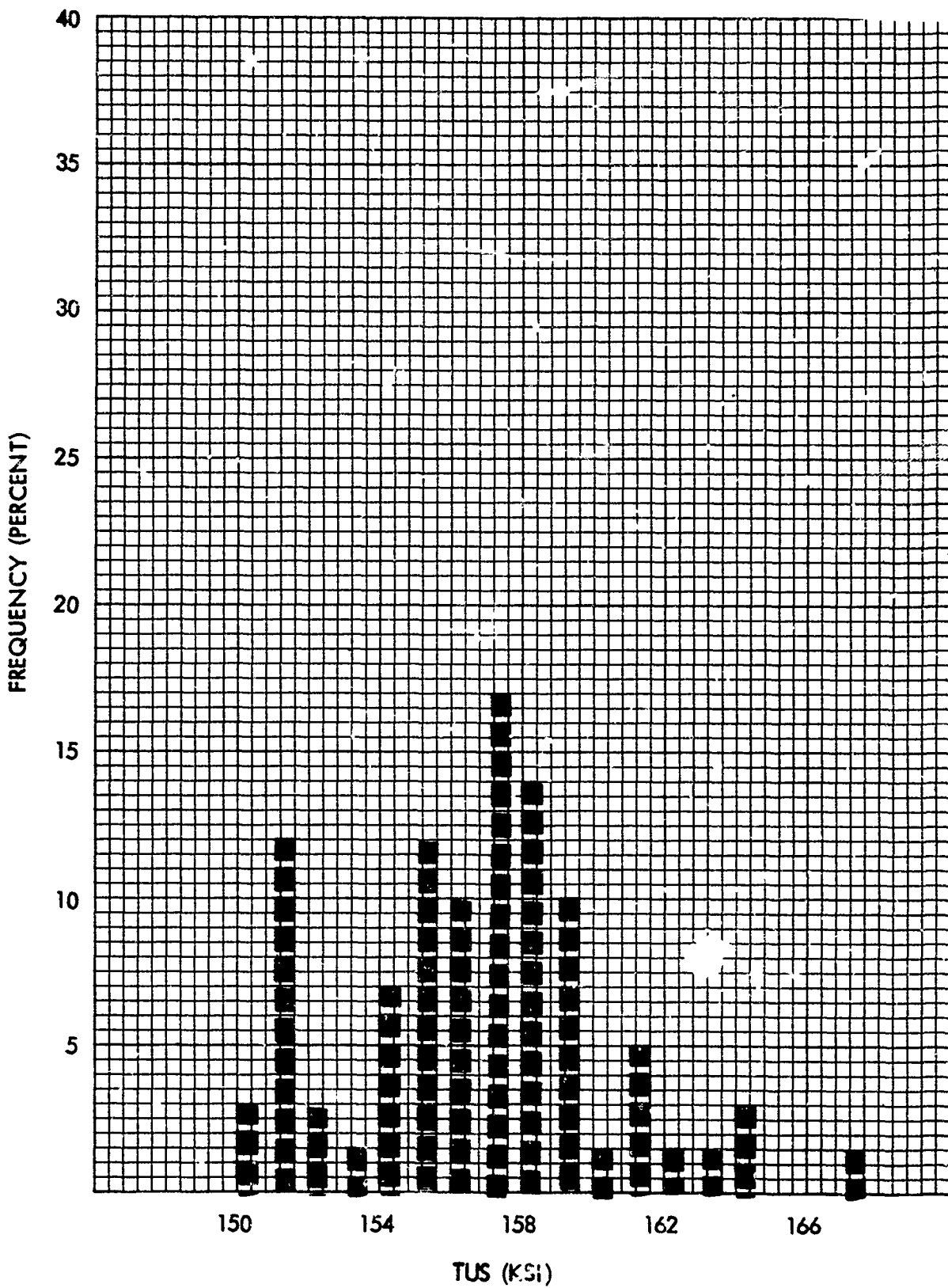

Figure 30. Typical Distribution of Test Results Annealed Ti-6Al-6V-2Sn Extrusions (60 Tests)

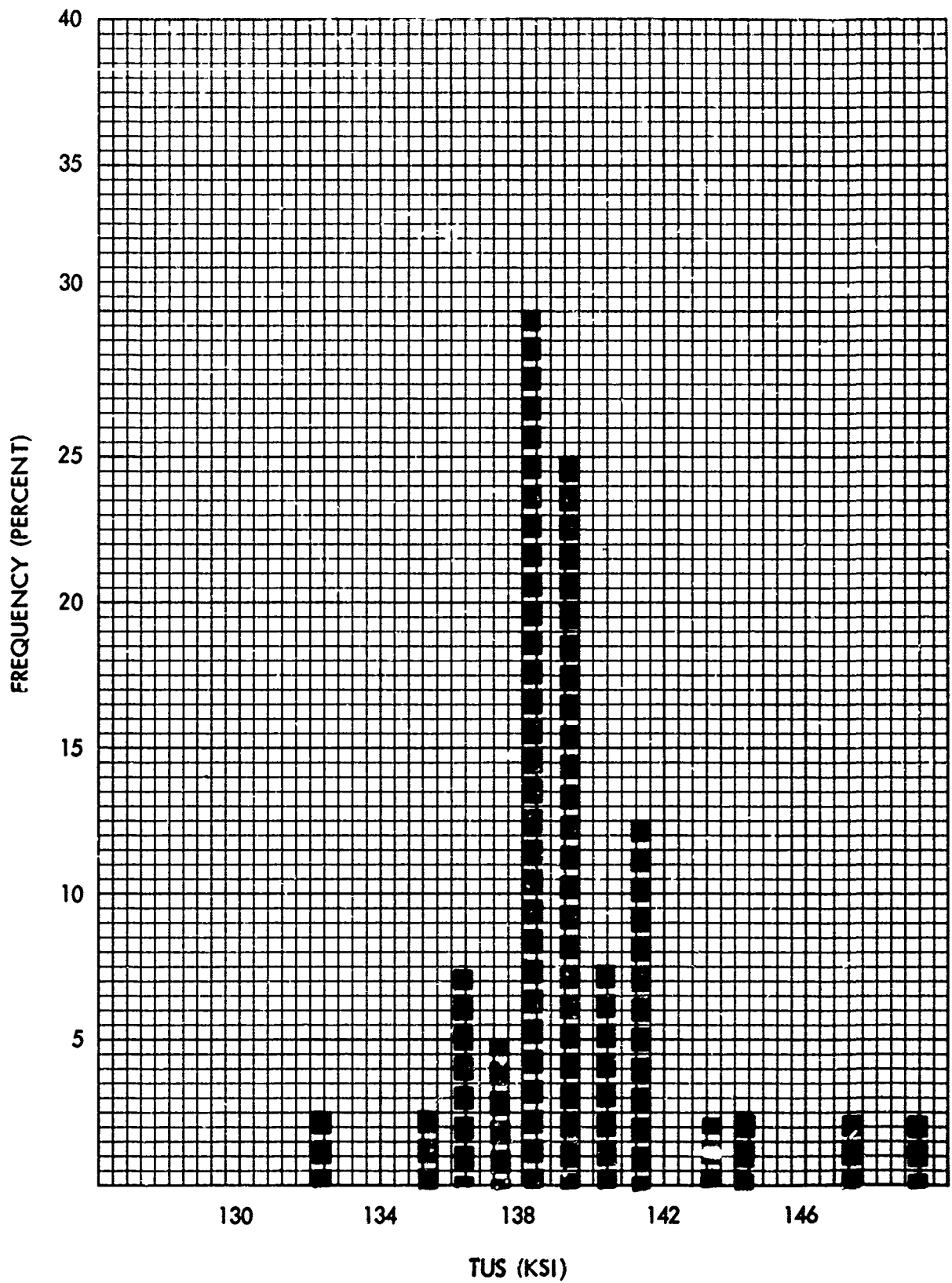

Figure 31. Typical Distribution of Test Results Annealed Ti-8Al-1Mo-LV Extrusions (40 Tests)

Two comparison points at each temperature (one from each vendor) were established in the longitudinal direction and one data point at each temperature in the transverse direction. Temperature effect relationships were consistent between vendors and grain directions. Tables VI, VII, and VIII indicate these trends.

Sufficient data points have not been established by this program to provide verification of the depth required for MIL-HDBK-5. The pattern thus far however is consistent and appears to indicate that the reduction in properties at elevated temperature is in excess of that shown in MIL-HDBK-5 for other product forms of these alloys. Comparison of temperature effects are shown in Figures 32 through 39, inclusive.

In the higher temperatures, effects on Ti-6Al-6V-2Sn appear to be less than on the other alloys. This follows trends in other Lockheed investigations covering other heat treat conditions, and follows patterns shown in MIL-HDBK-5 for other products.

BEARING

Results of tests for ultimate bearing strength and for bearing yield strength are summarized in Tables IX and X. The normal pattern of reduced strength at elevated temperature is followed, with alloys maintaining normal strength relationships. Effect of elevated temperature on the 600°F properties of Ti-6Al-6V-2Sn appears to be less than that of the other alloys - corresponding to the trends shown in properties such as tensile strength.

Agreement of values and of ratios between vendors is considered normal considering the limited number of data points. Ratios of ultimate bearing strength to ultimate strength, and of bearing yield strength to tensile yield strength are of the same general order of magnitude as those given in MIL-HDBK-5 for other product forms. Additional data points are required to define ratio and temperature effects more precisely.

SHEAR

Results of tests to determine ultimate shear strengths are summarized in Table XI.

Values obtained agree closely between vendors and between grain directions. Ratios of bearing strength to ultimate strength closely coincide with published values for other product forms, and temperature effect curves follow patterns established for other products.

Ti-6Al-6V-2Sn again shows less effect on properties from elevated temperature than that shown by the other alloys.

CREEP AND STRESS RUPTURE

Creep and stress rupture testing was initiated in accordance with the contract test schedule. Because of the resistant characteristics of the extruded product form to creep, the program was modified to provide stress rupture data

TABLE VI EFFECT OF TEMPERATURE ON THE ULTIMATE TENSILE STRENGTH OF TITANIUM ALLOY EXTRUSIONS

| Alloy | Piece | Test Direction | Percent of Room Temperature Strength | | | | |
|---------------|-------|----------------|--------------------------------------|-----|------|------|------|
| | | | -110F | RT | 400F | 600F | 800F |
| Ti-6Al-4V | A | L | 122 | 100 | 73 | 71 | 65 |
| | C | L | 121 | 100 | 73 | 70 | 66 |
| | A | T | 120 | 100 | 77 | 72 | 66 |
| Ti-8Al-1Mo-1V | F | L | 121 | 100 | 83 | 77 | 71 |
| | H | L | 117 | 100 | 79 | 71 | 66 |
| | F | T | 119 | 100 | 82 | 76 | 69 |
| Ti-6Al-6V-2Sn | L | L | 119 | 100 | 79 | 77 | 69 |
| | N | L | 118 | 100 | 85 | 79 | 74 |
| | L | T | 120 | 100 | 83 | 79 | 72 |

TABLE VII EFFECT OF TEMPERATURE ON TENSILE YIELD STRENGTH OF TITANIUM ALLOY EXTRUSION

| Alloy | Piece | Test Direction | Percent of Room Temperature Strength | | | | |
|---------------|-------|----------------|--------------------------------------|-----|------|------|------|
| | | | -110F | RT | 400F | 600F | 800F |
| Ti-6Al-4V | A | L | 128 | 100 | 71 | 61 | 58 |
| | C | L | 125 | 100 | 72 | 59 | 57 |
| | A | T | 127 | 100 | 70 | 62 | 57 |
| Ti-8Al-1Mo-1V | F | L | 130 | 100 | 72 | 65 | 58 |
| | H | L | 120 | 100 | 72 | 58 | 53 |
| | F | T | 126 | 100 | 73 | 65 | 58 |
| Ti-6Al-6V-2Sn | L | L | 127 | 100 | 72 | 69 | 62 |
| | N | L | 121 | 100 | 78 | 69 | 66 |
| | L | T | 127 | 100 | 76 | 69 | 64 |

TABLE VIII EFFECT OF TEMPERATURE ON THE COMPRESSIVE YIELD STRENGTH OF TITANIUM ALLOY EXTRUSIONS

| Alloy | Piece | Test Direction | Percent of Room Temperature Strength | | | | |
|---------------|-------|----------------|--------------------------------------|-----|------|------|------|
| | | | -110F | RT | 400F | 600F | 800F |
| Ti-6Al-4V | A | L | 125 | 100 | 67 | 57 | 56 |
| | C | L | 123 | 100 | 70 | 59 | 55 |
| | A | T | 125 | 100 | 69 | 59 | 56 |
| Ti-8Al-1Mo-1V | F | L | 125 | 100 | 72 | 60 | 57 |
| | H | L | 124 | 100 | 70 | 59 | 54 |
| | F | T | 125 | 100 | 71 | 61 | 56 |
| Ti-6Al-6V-2Sn | L | L | 127 | 100 | 74 | 67 | 62 |
| | N | L | 124 | 100 | 74 | 68 | 64 |
| | L | T | 127 | 100 | 74 | 67 | 63 |

only at 400°F, to provide both limited creep and stress-rupture data at 600°F and to provide a limited probe at 800°F creep characteristics. In addition, a probe was made of creep under conditions of rapid heating and loading such as might occur under over ride conditions. General airframe parameters were considered rather than such specialized applications as engines where extensive special creep investigations would be conducted.

400°F CHARACTERISTICS

Tests indicated that creep at 400°F should not be considered to be significant in general airframe design. In order to produce 0.1 percent strain in 1000 hours, Ti-6Al-4V and Ti-8Al-1Mo-1V specimens were loaded to approximately 95 percent of the ultimate strength at temperature, a level twenty to thirty percent above yield. The same level of stress produced 0.2 percent combined creep and strain deformation in Ti-6Al-6V-2Sn.

Stress Rupture at 400F is considered to be coincident with the ultimate tensile strength. Tests within a nominal 2 ksi of the ultimate tensile strength at temperature failed on loading or showed no failure at one week exposure. Since stress rupture characteristics were directed toward use in construction of fatigue diagrams the stress rupture curve was considered to coincide with the tensile strength within test limits.

600°F CHARACTERISTICS

Stress-rupture and nominal ultimate tensile strength at temperature were considered to be coincident. Ti-6Al-4V and Ti-6Al-6V-2Sn specimens loaded within 2 ksi of ultimate strength at temperature did not fail in 1000 hours of exposure. Tests of the Ti-8Al-1Mo-1V at the same relative load were discontinued at approximately 650 hours without failure.

Creep in Ti-8Al-1Mo-1V and in Ti-6Al-4V did not appear significant at the 600°F yield stress. Tests of Ti-8Al-1Mo-1V at yield strength indicate less than

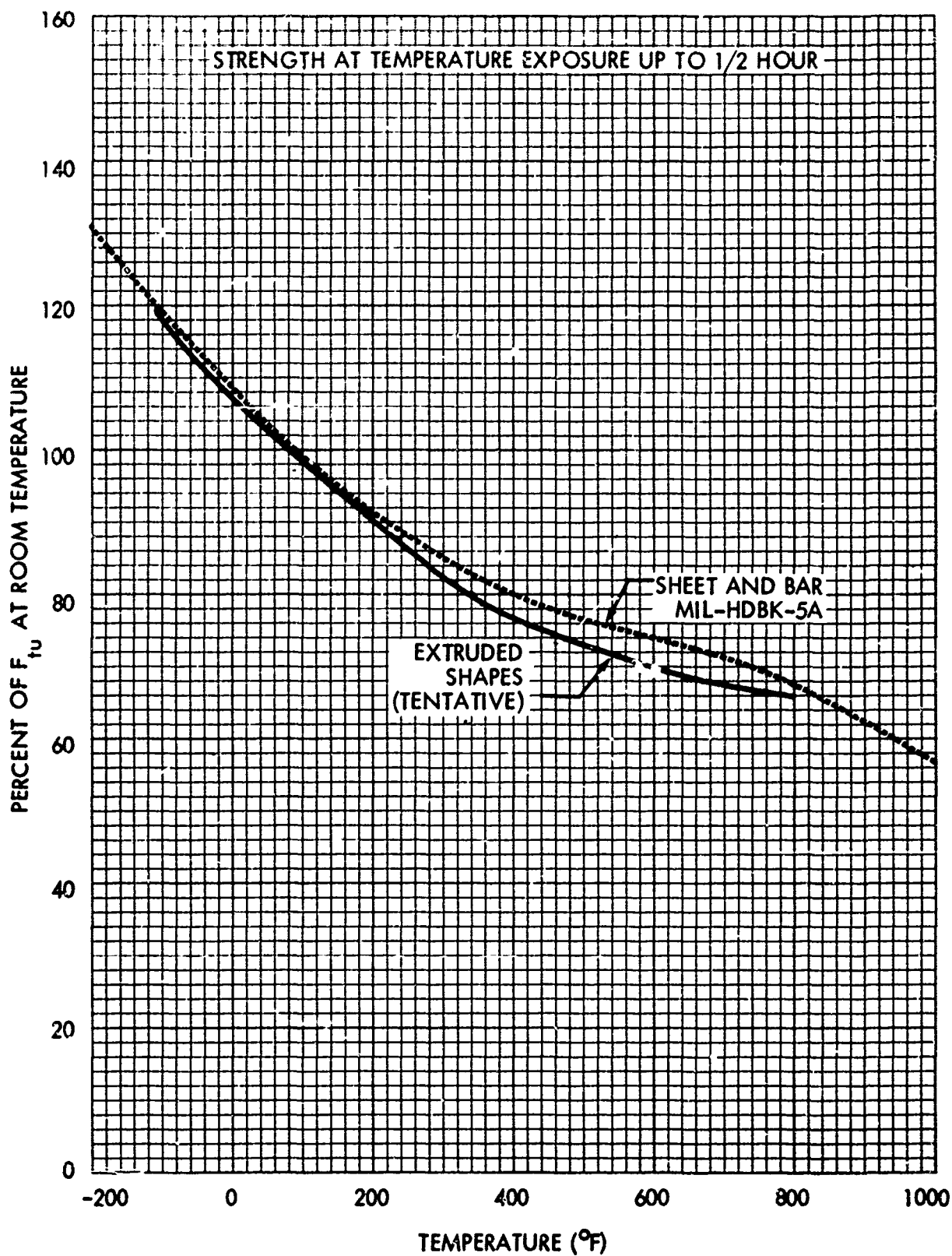

Figure 32. Comparison of Effect of Temperature on Ultimate Tensile Strength (F_{tu}) of Annealed Ti-6Al-4V Extrusion and Ti-6Al-4V Sheet and Bar

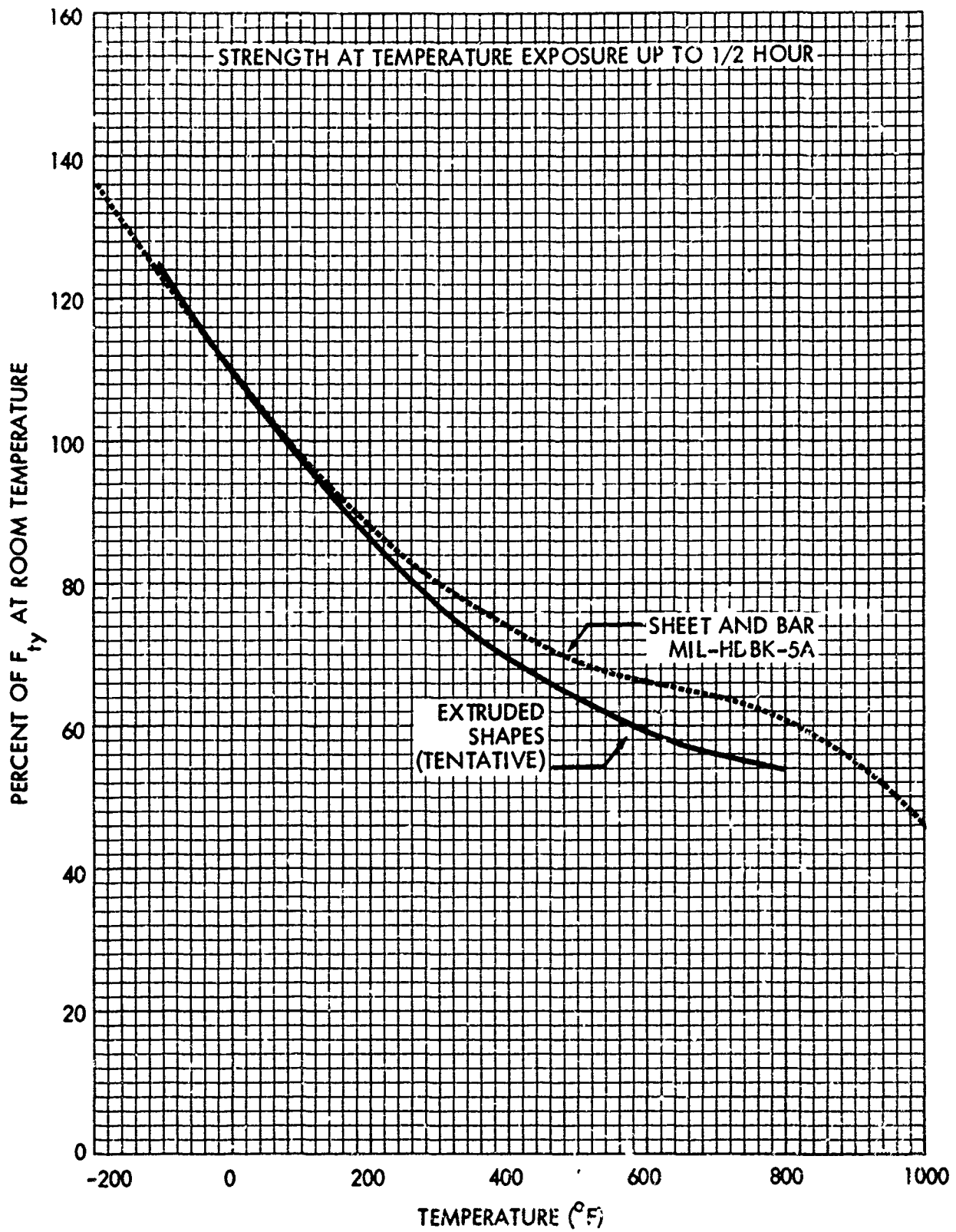

Figure 33. Comparison of the Effect of Temperature on the Tensile Yield Strength (F_{ty}) of Annealed Ti-6Al-4V Extrusion and Ti-6Al-4V Sheet and Bar

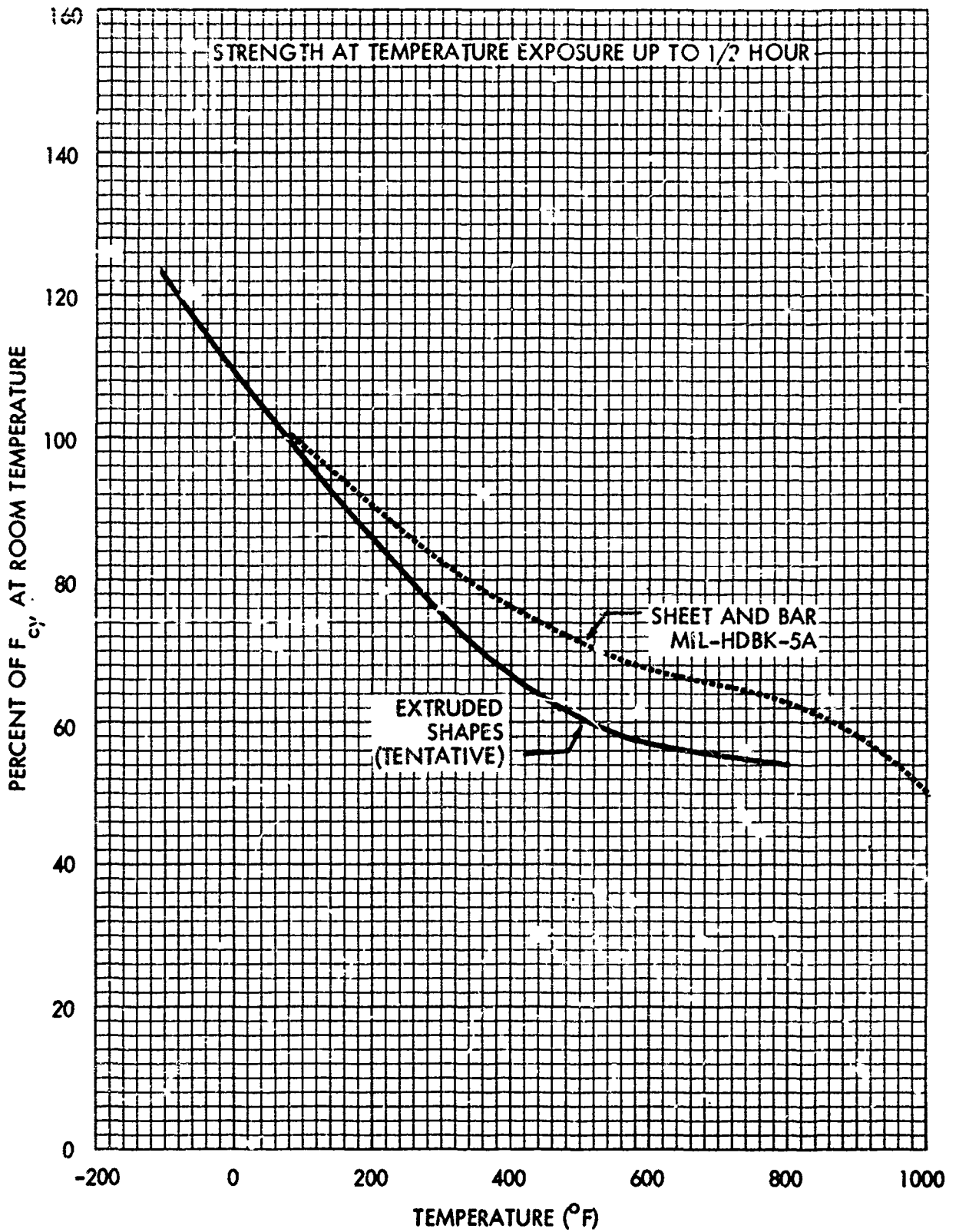

Figure 34. Comparison of the Effect of Temperature on the Compressive Yield Strength (F_{cy}) of Annealed Ti-6Al-4V Extrusion and Ti-6Al-4V Sheet and Bar

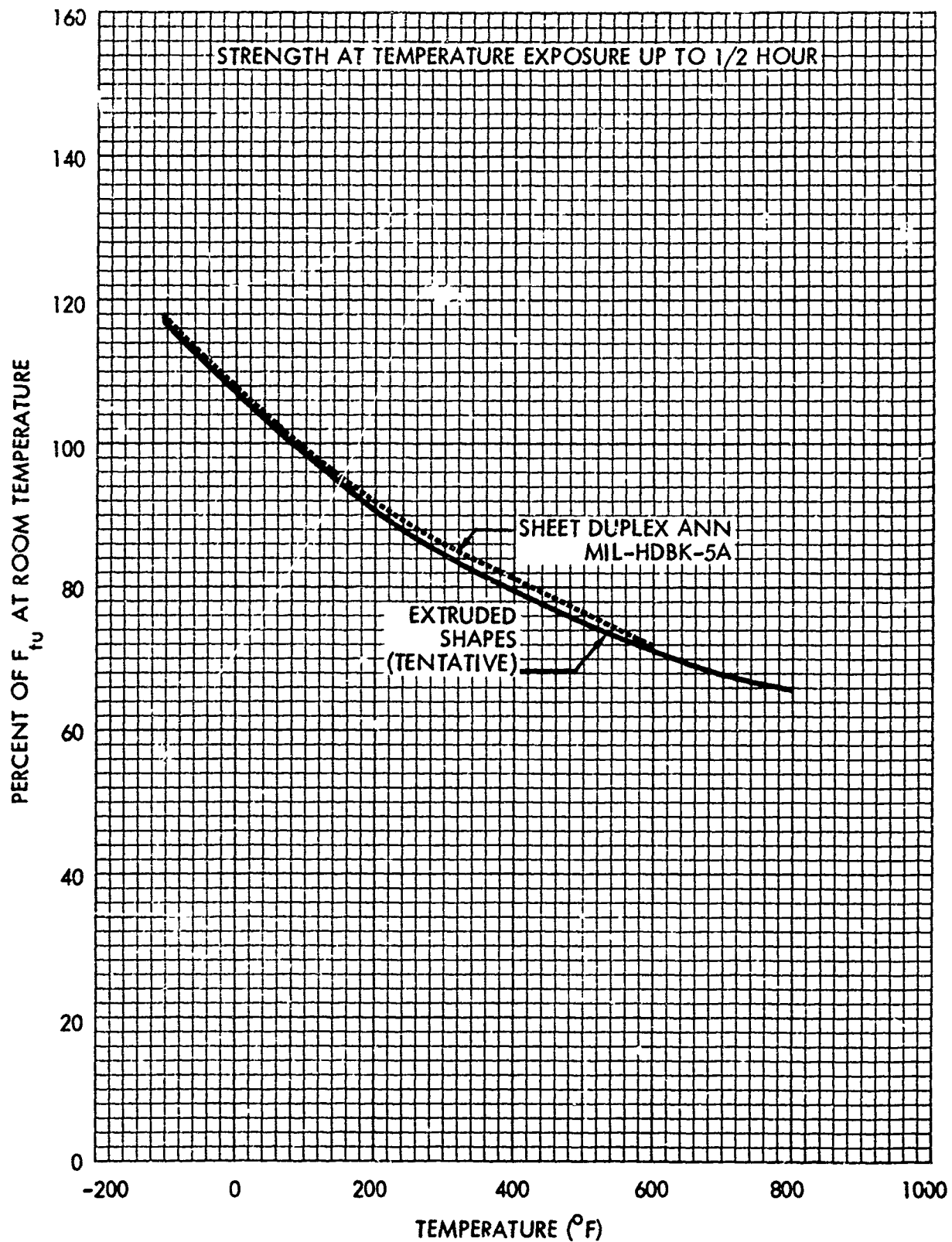

Figure 35. Comparison of the Effect of Temperature on the Ultimate Tensile Strength (F_{tu}) of Annealed Ti-8Al-1Mo-1V Extrusion and Ti-8Al-1Mo-1V Sheet

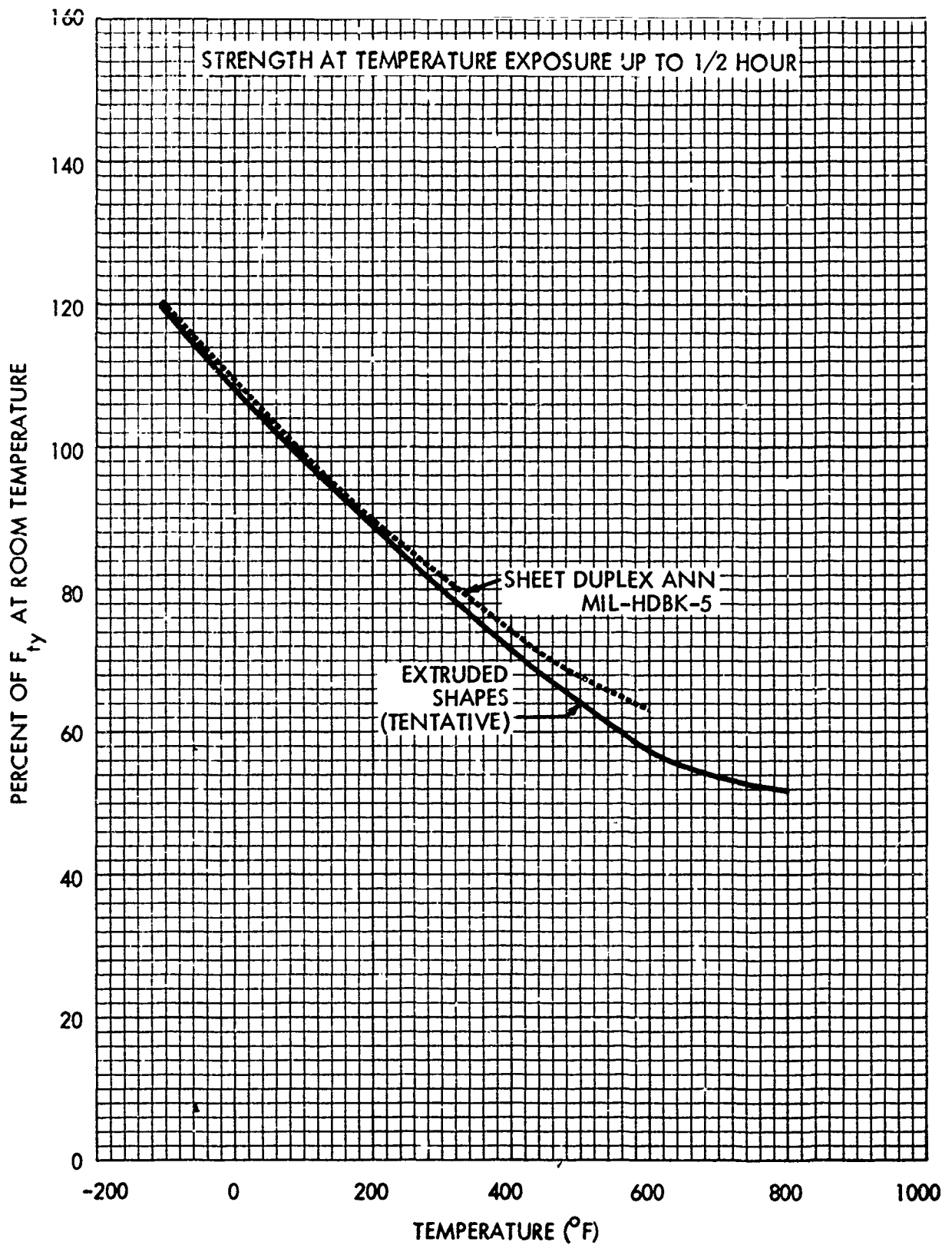

Figure 36. Comparison of the Effect of Temperature on the Tensile Yield Strength of Annealed Ti-8Al-1Mo-1V Extrusion and Ti-8Al-1Mo-1V Sheet

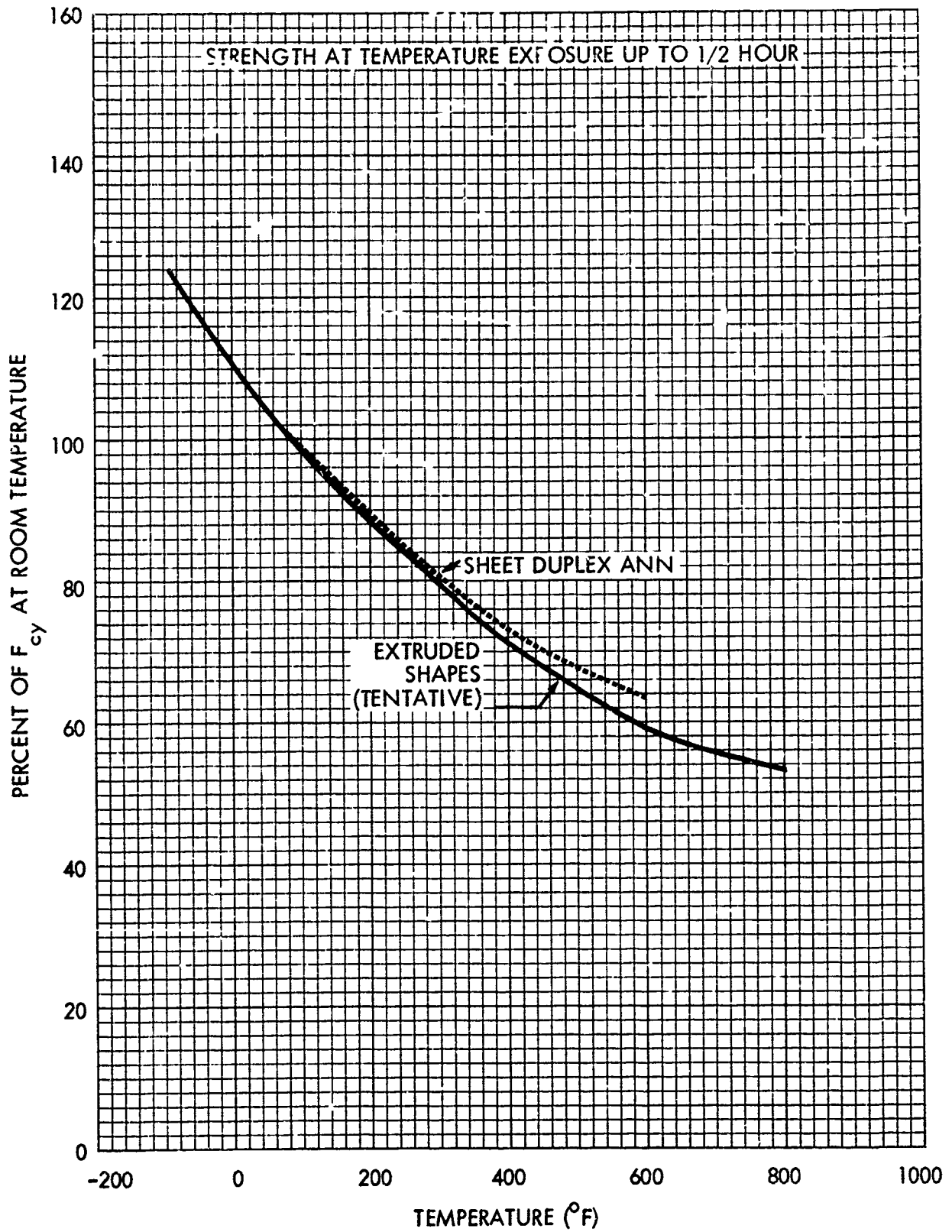

Figure 37. Comparison of the Effect of Temperature on the Compressive Yield Strength (F_{cy}) of Annealed Ti-8Al-1Mo-1V Extrusion and Ti-8Al-1Mo-1V Sheet

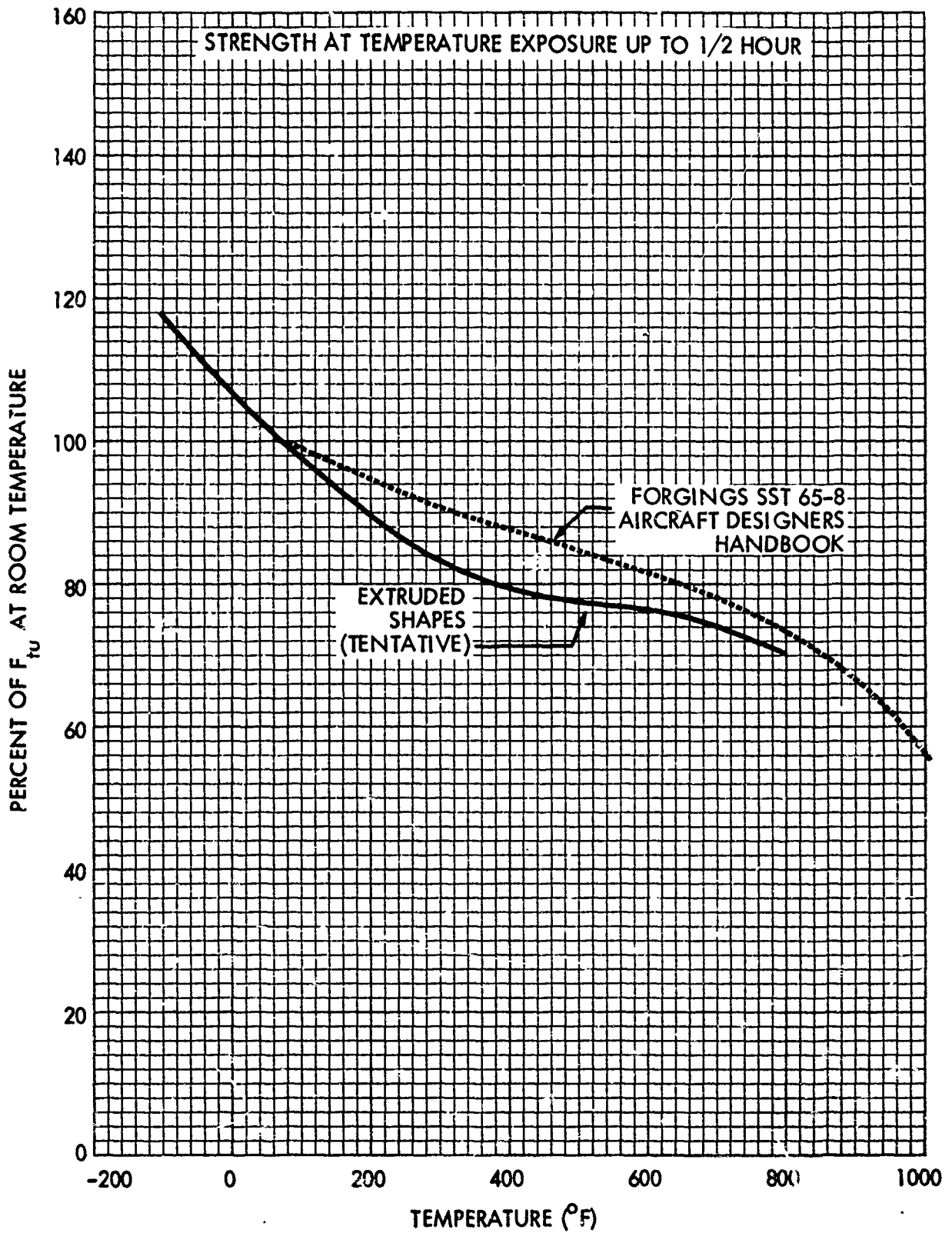

Figure 38. Comparison of the Effect of Temperature on the Ultimate Tensile Strength (F_{tu}) of Annealed Ti-6Al-6V-2Sn Extrusions and Ti-6Al-6V-2Sn Forgings

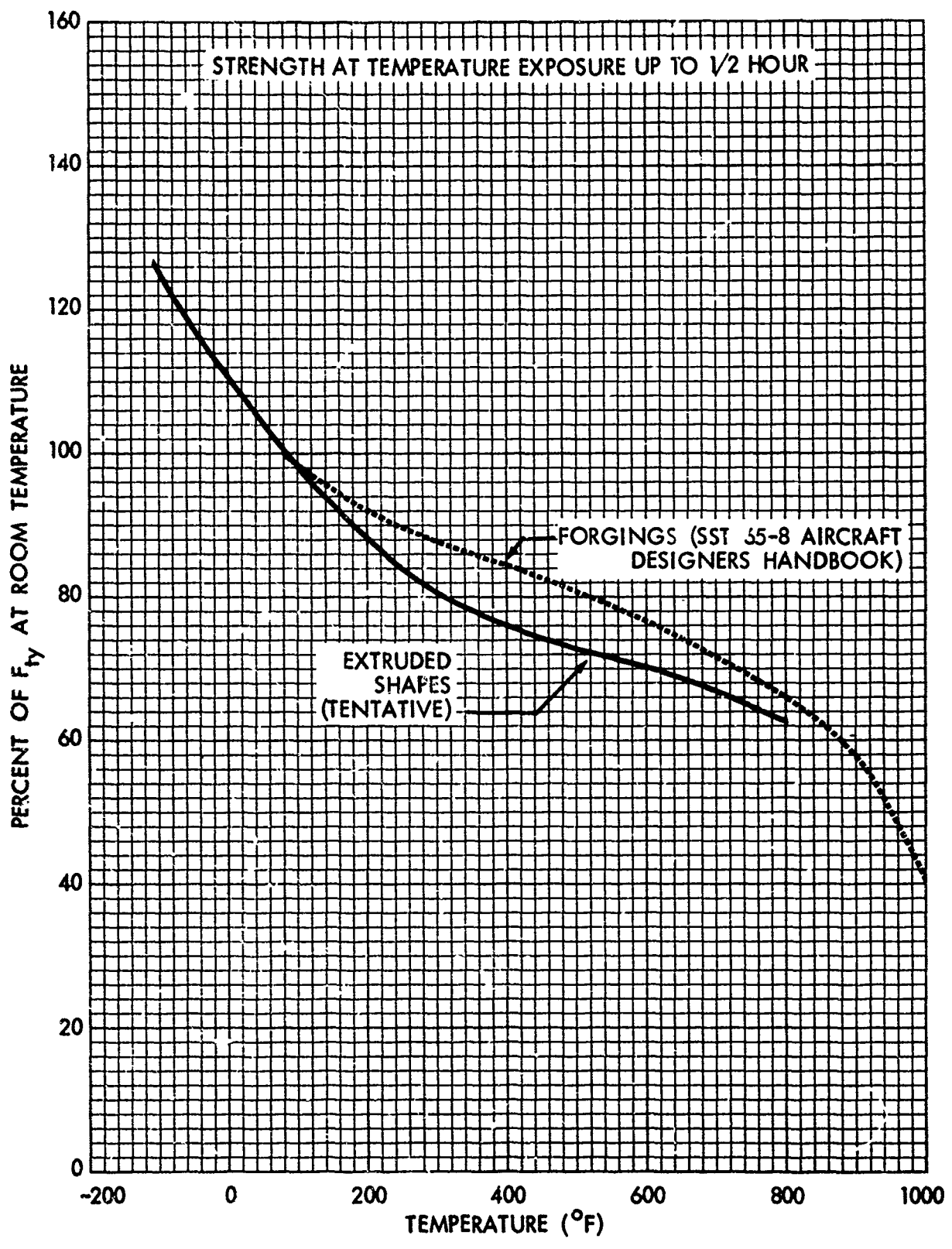

Figure 39. Comparison of Effect of Temperature on the Tensile Yield Strength (F_{ty}) of Annealed Ti-6Al-6V-2Sn Extrusions and Ti-6Al-6V-2Sn Forgings

TABLE IX ULTIMATE BEARING STRENGTHS OF
TITANIUM EXTRUSIONS \triangle

| Description | | | | Ultimate Bearing Strength at Temperature, Ksi | | | | Percent of TUS at RT |
|---------------|-------|-----------|-----|--|-----|------|------|-------------------------|
| Alloy | Piece | Direction | e/D | -110F | RT | 400F | 600F | |
| Ti-6Al-4V | A | L | 2.0 | 330 | 295 | 210 | 201 | 208 |
| | C | L | 2.0 | | 276 | 228 | 204 | 189 |
| | A | T | 2.0 | | 301 | 225 | | 212 |
| | C | T | 2.0 | | 296 | | | 203 |
| | A | L | 1.5 | | 244 | | | 172 |
| | C | L | 1.5 | | 247 | | | 169 |
| Ti-8Al-1Mo-1V | F | L | 2.0 | 323 | 292 | 220 | 192 | 210 |
| | H | L | 2.0 | | 270 | 215 | 191 | 200 |
| | F | T | 2.0 | | 291 | 222 | | 211 |
| | H | T | 2.0 | | 323 | | | 243 |
| | F | L | 1.5 | | 239 | | | 172 |
| | H | L | 1.5 | | 222 | | | 164 |
| Ti-6Al-6V-2Sn | L | L | 2.0 | 357 | 316 | 255 | 216 | 201 |
| | N | L | 2.0 | | 297 | 250 | 236 | 198 |
| | L | T | 2.0 | | 341 | 248 | | 214 |
| | N | T | 2.0 | | 317 | | | 208 |
| | L | L | 1.5 | | 269 | | | 171 |
| | N | L | 1.5 | | 252 | | | 168 |



Average of three tests

TABLE X BEARING YIELD STRENGTHS OF TITANIUM EXTRUSIONS ¹

| Description | | | | Bearing Yield Strength at Temperature, Ksi | | | | Percent of TYS at RT |
|---------------|-------|-----------|-----|--|-----|------|------|----------------------|
| Alloy | Piece | Direction | e/D | -110F | RT | 400F | 600F | |
| Ti-6Al-4V | A | L | 2.0 | 296 | 250 | 190 | 172 | 200 |
| | C | L | 2.0 | | 239 | 193 | 168 | 18 |
| | A | T | 2.0 | | 257 | 194 | | 202 |
| | C | T | 2.0 | | 255 | | | 196 |
| | A | L | 1.5 | | 208 | | | 166 |
| | C | L | 1.5 | | 210 | | | 163 |
| Ti-8Al-1Mo-1V | F | L | 2.0 | 282 | 240 | 185 | 167 | 192 |
| | H | L | 2.0 | | 221 | 172 | 152 | 184 |
| | F | T | 2.0 | | 249 | 192 | | 201 |
| | H | T | 2.0 | | 268 | | | 227 |
| | F | L | 1.5 | | 201 | | | 161 |
| | H | L | 1.5 | | 186 | | | 155 |
| Ti-6Al-6V-2Sn | L | L | 2.0 | 329 | 279 | 224 | 205 | 199 |
| | N | L | 2.0 | | 254 | 218 | 201 | 190 |
| | L | T | 2.0 | | 290 | 222 | | 207 |
| | N | T | 2.0 | | 270 | | | 197 |
| | L | L | 1.5 | | 231 | | | 165 |
| | N | L | 1.5 | | 223 | | | 166 |



Average of three tests

TABLE XI SHEAR STRENGTH OF TITANIUM ALLOY EXTRUSIONS \triangle ¹

| Description | | | Shear Strength at Temperature, ksi | | | | Percent of TUS at RT |
|--|-------|-----------|------------------------------------|-----|--------------------------|------|----------------------|
| Alloy | Piece | Direction | -110F | RT | 400F | 600F | |
| Ti-6Al-4V | A | L | 106 | 92 | 77 | 70 | 65 |
| | C | L | | 91 | 77 | 70 | 62 |
| | A | T | | 92 | | | 65 |
| | C | T | | 92 | 76.3 | | 63 |
| Ti-8Al-1Mo-1V | F | L | 102 | 91 | 79 | 69 | 65 |
| | H | L | | 87 | \triangle ² | 68 | 64 |
| | F | T | | 87 | | | 63 |
| | H | T | | 88 | 75 | | 66 |
| Ti-6Al-6V-2Sn | L | L | 119 | 101 | 90 | 81 | 64 |
| | N | L | | 101 | \triangle ² | 83 | 67 |
| | L | T | | 102 | | | 64 |
| | N | T | | 100 | 88 | | 66 |
| \triangle ¹ Average of three tests | | | | | | | |
| \triangle ² Results not tabulated because of abnormal bending | | | | | | | |

0.1 percent creep is 1000 hours. Ti-6Al-4V showed 0.1 percent creep in 1000 hours at stress levels 10 percent above yield. Ti-6Al-6V-2Sn showed more susceptibility, with approximately 0.2 percent creep indicated after 500 hours exposure, and approximately 0.4 percent in 1000 hours.

At 800°F creep becomes significant in all alloys. As at all other temperatures, Ti-8Al-1Mo-1V showed the highest degree of resistance, while Ti-6Al-6V-2Sn showed most susceptibility.

Creep tests conducted under conditions of rapid heating and rapid loading result in higher strains than those produced by standard creep exposures, except for Ti-6Al-6V-2Sn. Results of these tests would indicate the desirability of further testing in this area because of the close relationships between this type test and occasional extreme exposure. Relationships between creep under conditions of rapid heat and load compared with creep under standard conditions are shown in Table XII.

Creep data are susceptible to scatter because of minor variations in test procedure and considerable scatter is shown in the data obtained in this program. This does not, within this program, affect interpretation of results.

IMPACT PROPERTIES

Results of Charpy impact tests indicate generally higher values for transverse specimens than for longitudinal specimens at all temperatures. This does not seem reflected in any other properties, but could be due to the notch occur-

TABLE XII COMPARISON OF CREEP STRAIN
UNDER VARYING LOADING CONDITIONS

| Alloy | Temp | Stress (Ksi) | Creep Strain in/in | | | | | |
|---------------|------|-----------------|---------------------|--------|--------|----------------|--------|--------|
| | | | Rapid Heat And Load | | | Standard Creep | | |
| | | | 5 min | 30 min | 60 min | 1 hr | 100 hr | 500 hr |
| Ti-6Al-4V | 600F | 71 | 0.0012 | 0.0017 | 0.0018 | | | |
| | | 79 | 0.0006 | 0.0022 | 0.0029 | 0.0006 | | 0.0027 |
| | | 85 | 0.0007 | 0.0020 | 0.0030 | | | |
| | | 89 | | | | 0.0006 | 0.0009 | 0.0010 |
| | 800F | 58 | 0.0004 | 0.0010 | 0.0012 | | | |
| | | 65 | 0.0005 | 0.0007 | 0.0007 | | | |
| | | 75 | 0.0004 | 0.0018 | 0.0028 | 0.0014 | 0.0183 | |
| Ti-8Al-1Mo-1V | 600F | 81 | 0.0004 | | 0.0006 | 0.0004 | 0.0005 | 0.0006 |
| | 800F | 58 | 0.0002 | 0.0008 | 0.0010 | | | |
| | | 72 | 0.0003 | 0.0006 | 0.0007 | 0.0003 | 0.0028 | 0.005 |
| | | 85 | 0.0008 | 0.0017 | 0.0020 | 0.0006 | 0.0046 | 0.008 |
| Ti-6Al-6V-2Sn | 600F | 90 | | | | | | |
| | | 100 | 0.0004 | 0.0006 | 0.0006 | 0.0004 | 0.0016 | 0.0024 |
| | | 112 | 0.0009 | 0.0018 | 0.0018 | 0.0006 | 0.0024 | |
| | 800F | 69 | 0.0008 | 0.0029 | 0.0048 | | | |
| | | 88 | 0.0015 | 0.0067 | 0.0105 | | | |
| | | 98 | 0.0059 | 0.0242 | 0.0428 | | | |

ring in the junction area. Impact toughness varies inversely with alloy strength as expected. The tests at minus 110°F represent specimens machined and tested separately from other specimens and, therefore, are considered to represent a variable in test rather than a reversal of trend in impact properties. Test results are shown in Figures 40, 41, and 42.

FRACTURE TOUGHNESS AND DELAYED FAILURE

K_{Ic} fracture toughness values at -110°F and at room temperature, along with delayed failure characteristics are given in Table XIII. Values obtained in this program agree within expected scatter with values obtained on similar material evaluated as part of recent programs at Lockheed, and are less than scatter observed in heavy products such as forgings. Ti-8Al-1Mo-1V presents the most favorable fracture toughness characteristics, but appears to have slightly inferior delayed failure characteristics. Delayed failure of Ti-8Al-1Mo-1V extrusions, air-cooled, appear to be superior to past values obtained using furnace-cooled materials and are above values obtained in the past on annealed bar worked in the alpha-beta field.

Figures 43, 44, and 45 depict delayed failure as a function of time.

FATIGUE

Results of the fatigue tests on the three titanium alloys tested are presented as S/N curves in Section V. Figure numbers of curves are as follows:

| <u>Alloy</u> | <u>K_T</u> | <u>A</u> | <u>Temp</u> | <u>Fig. No.</u> |
|---------------|-------------------------|---------------------|-------------|-----------------|
| Ti-6Al-4V | 1.0 | 0.98 | RT | 54 |
| | 2.76 | $\infty, 0.98, 0.4$ | RT | 55 |
| | 2.76 | $\infty, 0.98, 0.4$ | 400°F | 56 |
| | 2.76 | $\infty, 0.98, 0.4$ | 600°F | 57 |
| Ti-8Al-1Mo-1V | 1.0 | 0.98 | RT | 66 |
| | 2.76 | $\infty, 0.98, 0.4$ | RT | 67 |
| | 2.76 | $\infty, 0.98, 0.4$ | 400°F | 68 |
| | 2.76 | $\infty, 0.98, 0.4$ | 600°F | 69 |
| Ti-6Al-6V-2Sn | 1.0 | 0.98 | RT | 78 |
| | 2.76 | $\infty, 0.98, 0.4$ | RT | 79 |
| | 2.76 | $\infty, 0.98, 0.4$ | 400°F | 80 |
| | 2.76 | $\infty, 0.98, 0.4$ | 600°F | 81 |

Fatigue characteristics of the three alloys were considered to be similar in the same scatter band. Values were intermediate in relation to those seen in previous evaluations of extruded products. Values appear to be below those shown in MIL-HDBK-5, but do not appear to be below typical values seen in other programs on heavy sections such as bar, plate, or forgings.

Material from one vendor tends to show slightly higher fatigue values than that of the other. At this time, this is considered to represent random scatter

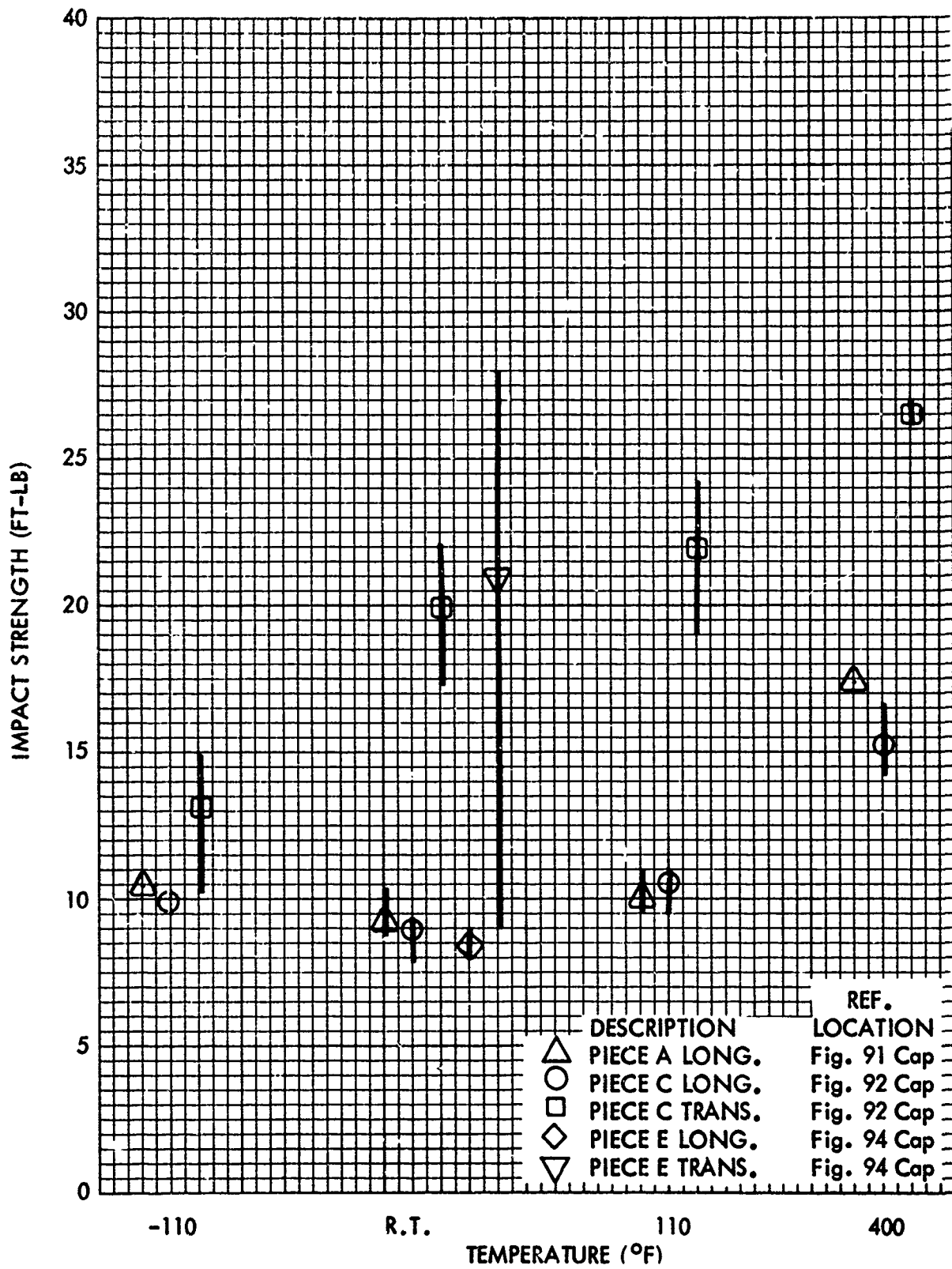

Figure 40. Charpy Impact Properties of Ti-6Al-4V Extrusions

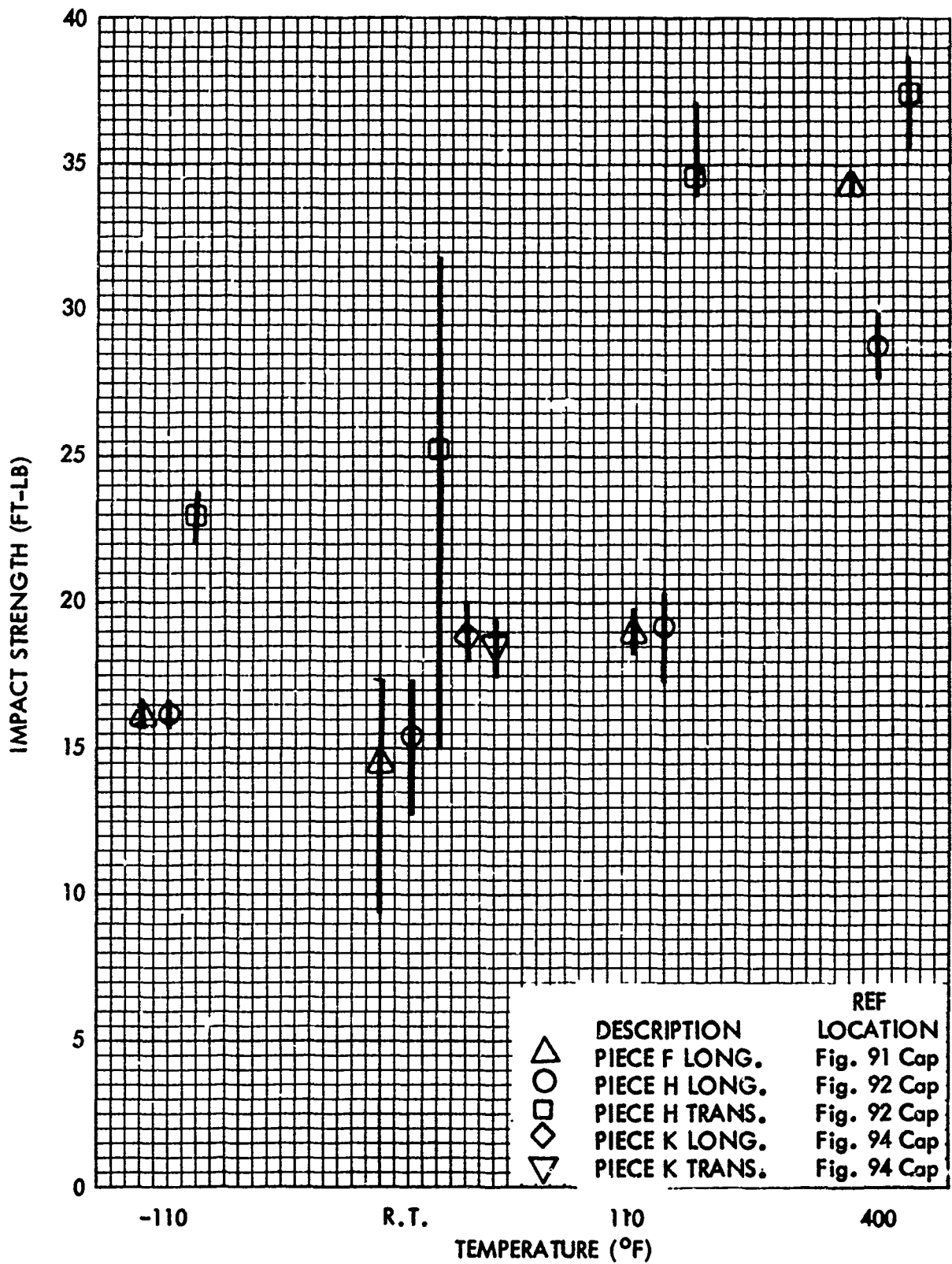

Figure 41. Charpy Impact Properties of Ti-8Al-1Mc-1V Extrusions

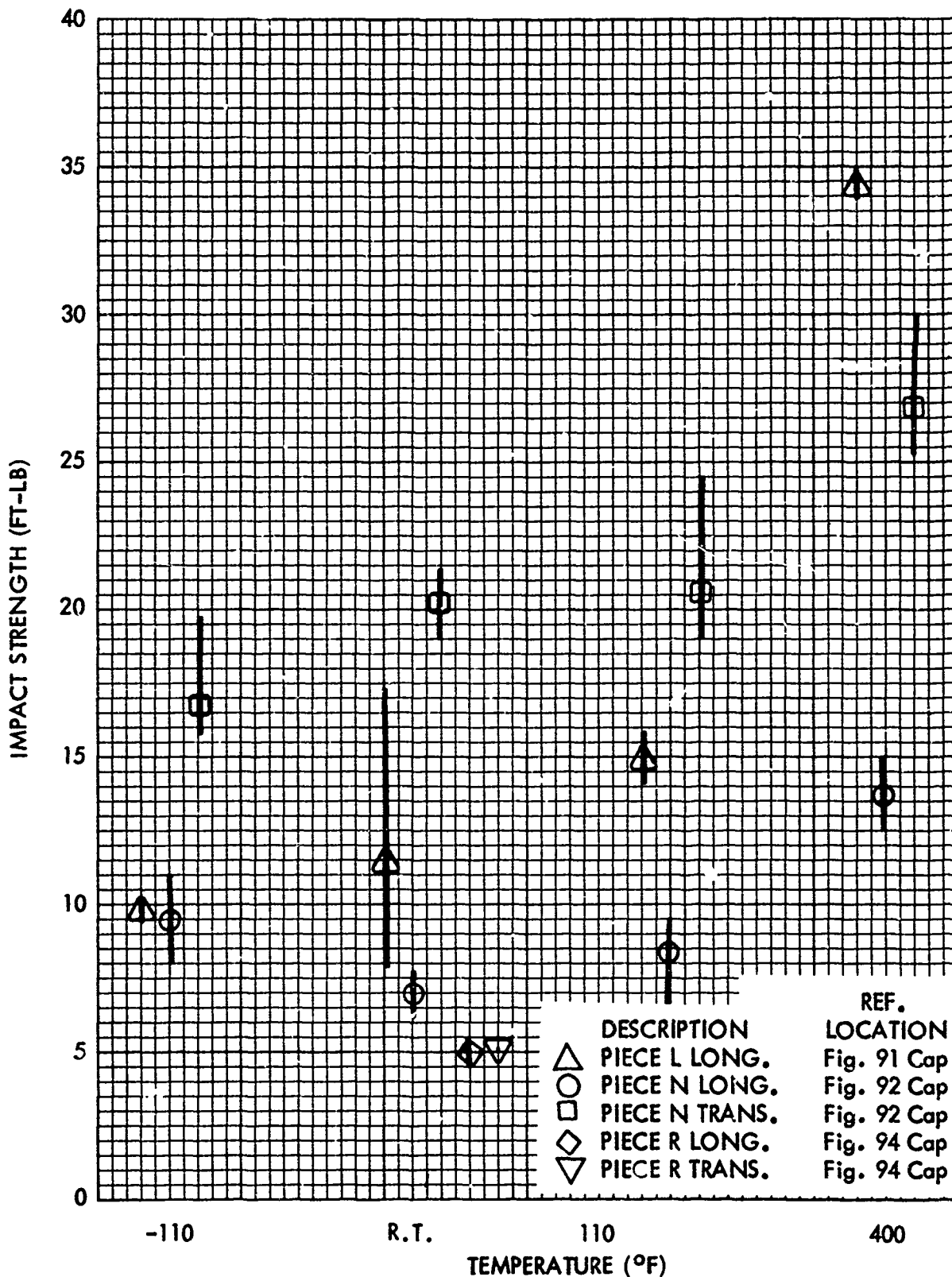

Figure 42. Charpy Impact Properties of Ti-6Al-6V-2Sn Extrusions

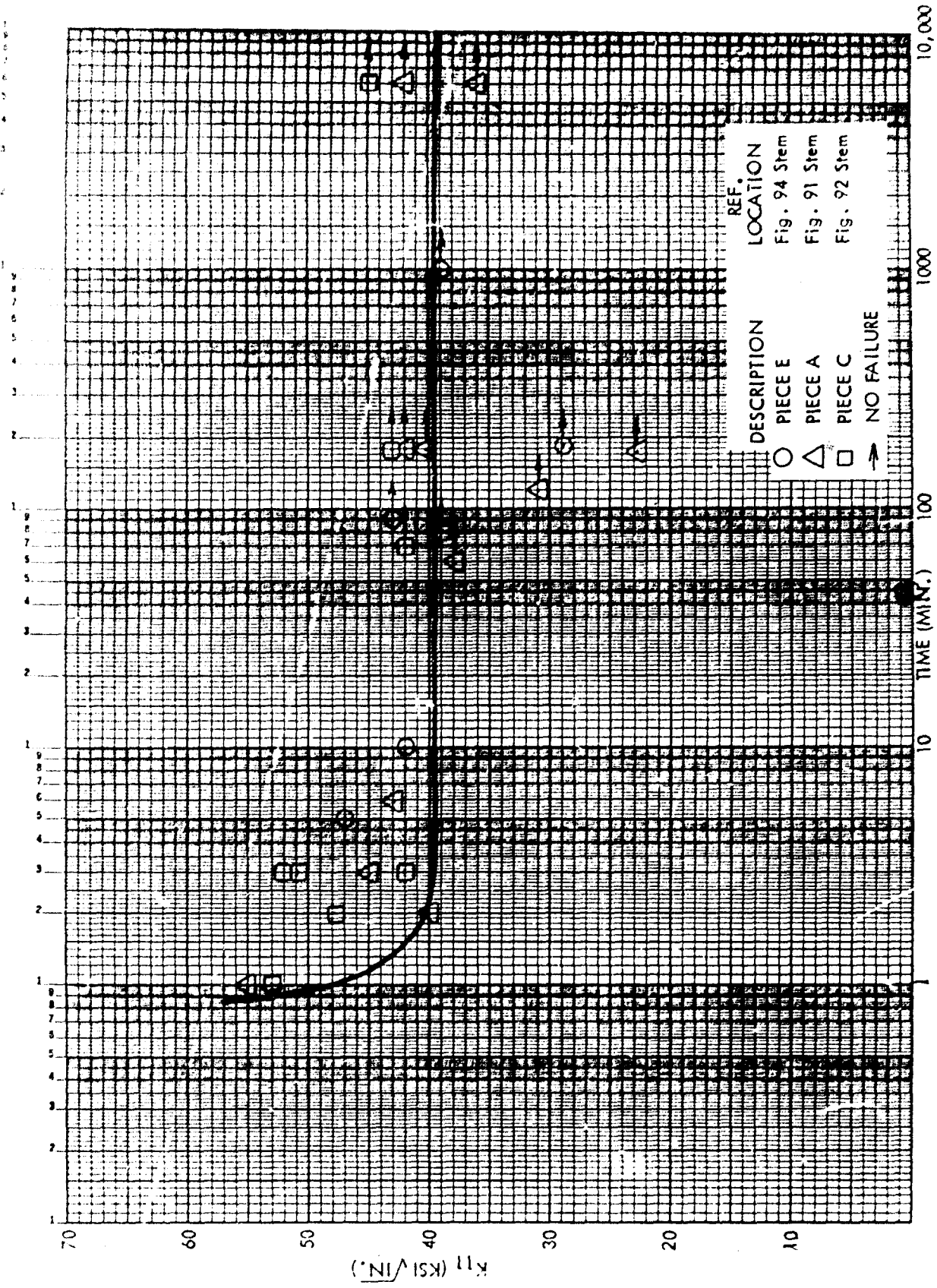

Figure 43. Delayed Failure Characteristics of Ti-6Al-4V Extrusions

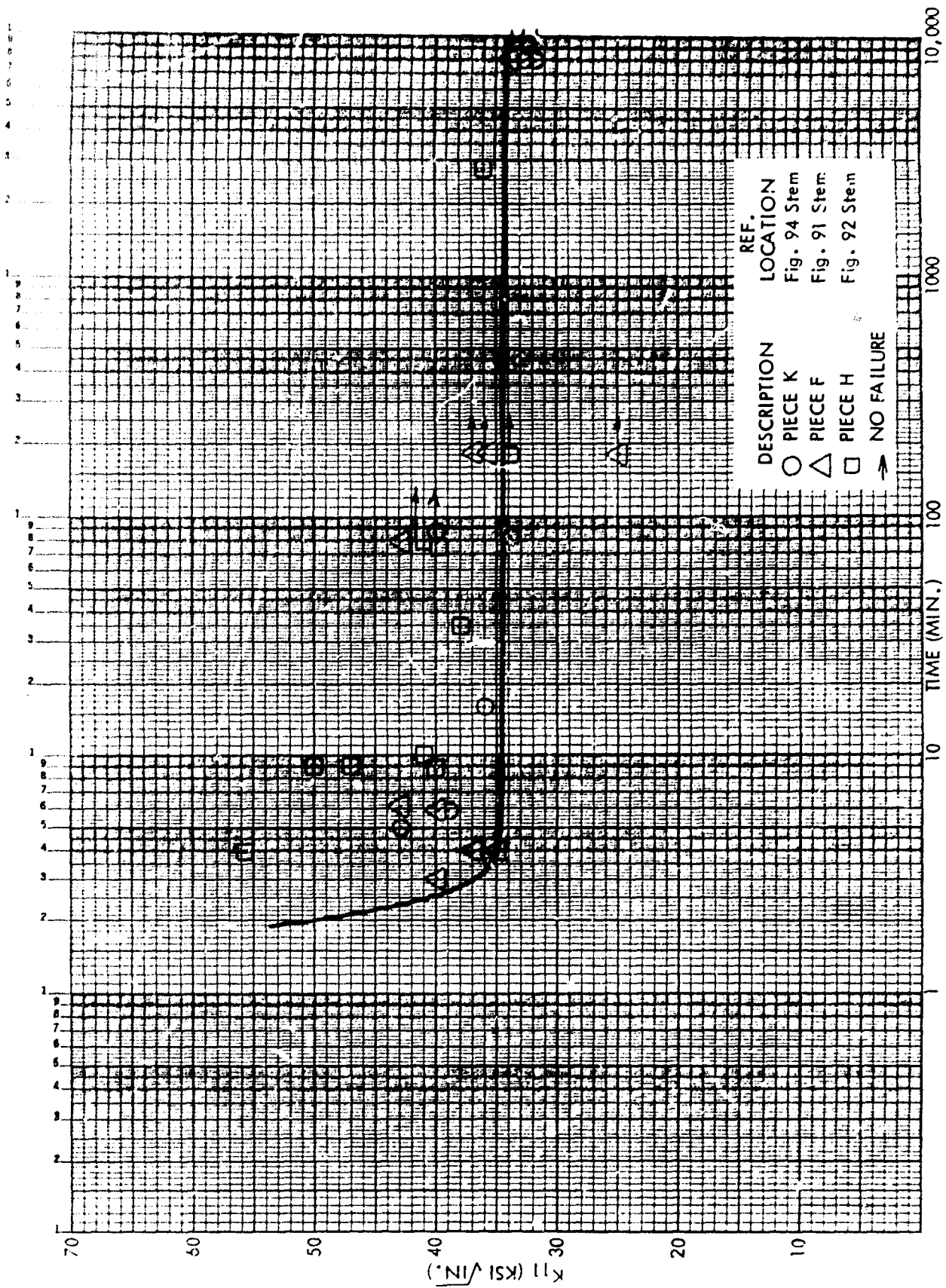

Figure 44. Delayed Failure Characteristics of Ti-8Al-1Mo-1V Extrusions

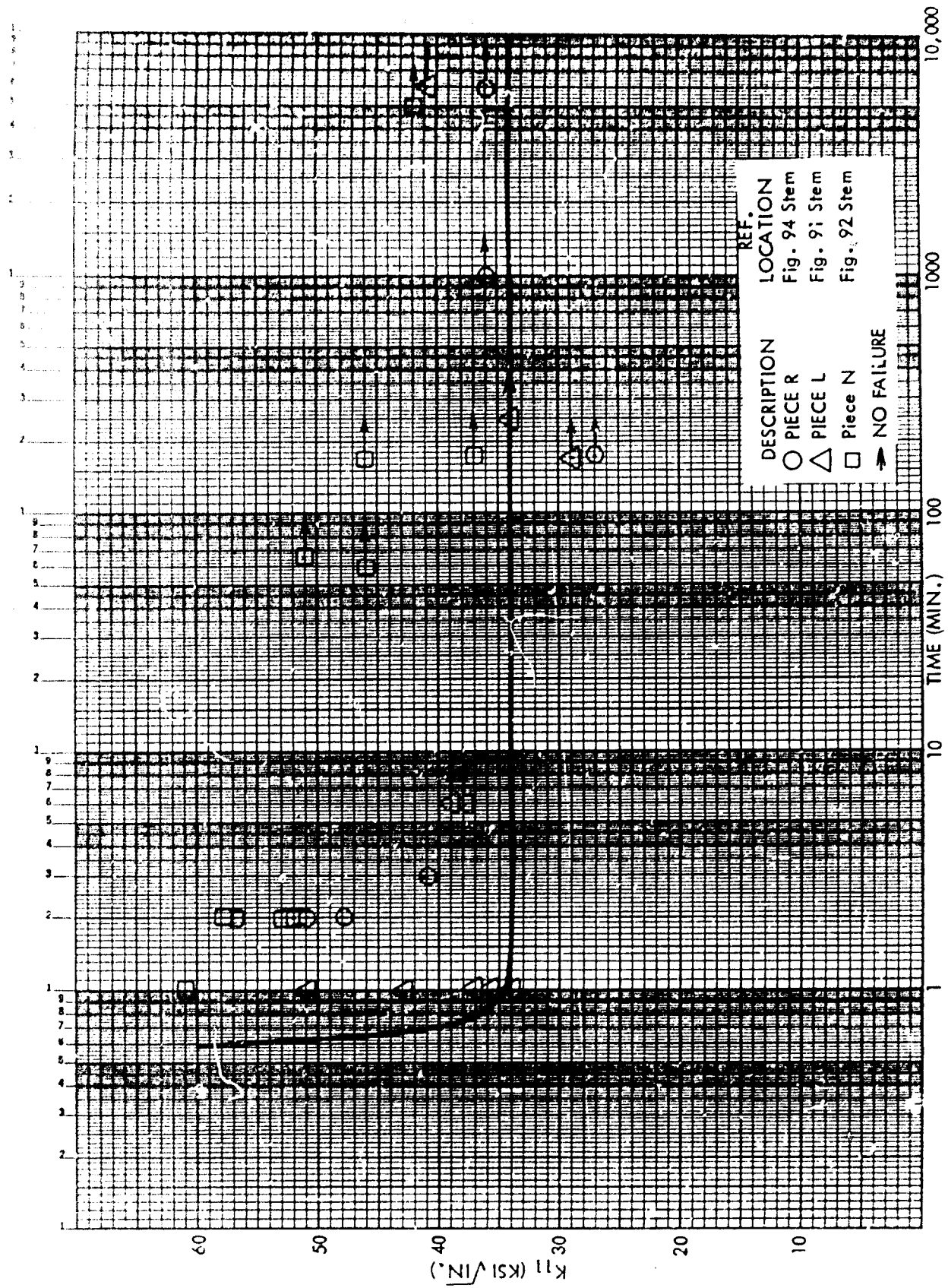

Figure 45. Delayed Failure Characteristics of Ti-6Al-6V-2Sn Extrusions

TABLE XIII FRACTURE TOUGHNESS AND DELAYED FAILURE
CHARACTERISTICS OF TITANIUM ALLOY EXTRUSIONS

| Alloy | Piece | Grain Direction | K_{Ic} (ksi $\sqrt{in.}$) | | K_{Ti} (ksi $\sqrt{in.}$) | |
|---------------|-------|-----------------|------------------------------|----|------------------------------|--------|
| | | | -110F | RT | Held | Failed |
| Ti-6Al-4V | A | L | 68 | 73 | 36 | 40 |
| | C | L | 63 | 65 | 45 | 48 |
| | E | L | | 79 | 39 | 42 |
| Ti-8Al-1Mo-1V | F | L | 76 | 83 | 34 | 35 |
| | H | L | 88 | 88 | 34 | 36 |
| | K | L | | 85 | 34 | 36 |
| Ti-6Al-6V-2Sn | L | L | 46 | 58 | 29 | 34 |
| | N | L | 56 | 72 | 42 | 57 |
| | R | L | | 58 | 36 | 41 |

until effect of processing variables on fatigue can be determined through other programs.

Elevated temperatures seem to affect only the high-cycle end of the fatigue curves. Alloys Ti-6Al-4V and Ti-8Al-1Mo-1V seem to see more effect than Ti-6Al-6V-2Sn. This trend has been observed on previous programs.

Modified Goodman diagrams prepared from data obtained in this program are presented in Figures 58, 59, 72, 73, 86 and 87.

Section V

PRELIMINARY DESIGN INFORMATION

Tentative design properties for extruded titanium alloys Ti-6Al-4V, Ti-8Al-1Mo-1V, and Ti-6Al-6V-2Sn in the Annealed tempers are presented in this Section. Current specifications for these products are not established on a government nor an industry basis*. Design properties are indicated as tentative until such time as sufficient depth of data (and corresponding modifications) to meet MIL-HDBK-5 standards are compiled and incorporated.

Ti-6Al-4V TENTATIVE DESIGN PROPERTIES

- (1) Tentative room temperature design mechanical properties are summarized in Table XIV.
- (2) Effect of temperature on ultimate tensile strength at temperature is shown in Figure 46. Effect of temperature on tensile yield strength is shown in Figure 47. Effect of temperature on compressive yield strength is shown in Figure 48. Effect of temperature on shear and on bearing properties are shown in Figures 49, 50, and 51.
- (3) Stress-strain curves in tension and compression (typical curves) are shown in Figures 52 and 53.
- (4) S/N diagrams showing typical room temperature and elevated temperature fatigue characteristics of smooth and of notched specimens are shown in Figures 54, 55, 56, and 57, modified Goodman diagrams in Figures 58 and 59.
- (5) Discussion of fracture toughness, and of delayed failure characteristics is included in Section IV.
- (6) Discussion of fracture toughness, and of delayed failure characteristics is included in Section IV.

Ti-8Al-1Mo-1V TENTATIVE DESIGN PROPERTIES

- (1) Tentative room temperature design mechanical properties are summarized in Table XV.

*AMS4935 in its present form (Revision A) is not normally used without exceptions.

Table XIV Tentative Design Mechanical and Physical Properties
of Ti-6Al-4V Titanium Alloy (Extrusions)

| | |
|---|------------------------------------|
| Alloy | Ti-6Al-4V |
| Form | Extruded Shapes, Rod and Bar |
| Condition | Annealed |
| Thickness or diameter, in. | All |
| Basis | S |
| Mechanical properties: | |
| F _{tu} , ksi | 135 |
| L | 135 |
| L _T | 135 |
| F _{ty} , ksi | 125 |
| L | 125 |
| L _T | 125 |
| F _{cy} , ksi | (Typical Values Shown in Table IV) |
| L | |
| L _T | (Typical Values Shown in Table XI) |
| F _{su} , ksi | (Typical Values Shown in Table IX) |
| F _{br} , ksi: | |
| (e/D = 1.5) | |
| (e/D = 2.0) | |
| F _{br} , ksi: | |
| (e/D = 1.5) | (Typical Values Shown in Table X) |
| (e/D = 2.0) | |
| e, per cent: | |
| In 2 in. | 10 |
| In 4 D | 10 |
| E, 10 ⁶ psi | 16.9 / |
| E _c , 10 ⁶ psi | |
| G, 10 ⁶ psi | |
| μ | |
| Physical properties: | |
| ω, lb/in. ³ | 0.160 |
| C, Btu/(lb)(F) | |
| K, Btu/[(hr)(ft ²)(F)/ft] | |
| α, 10 ⁻⁶ in./in./F | |

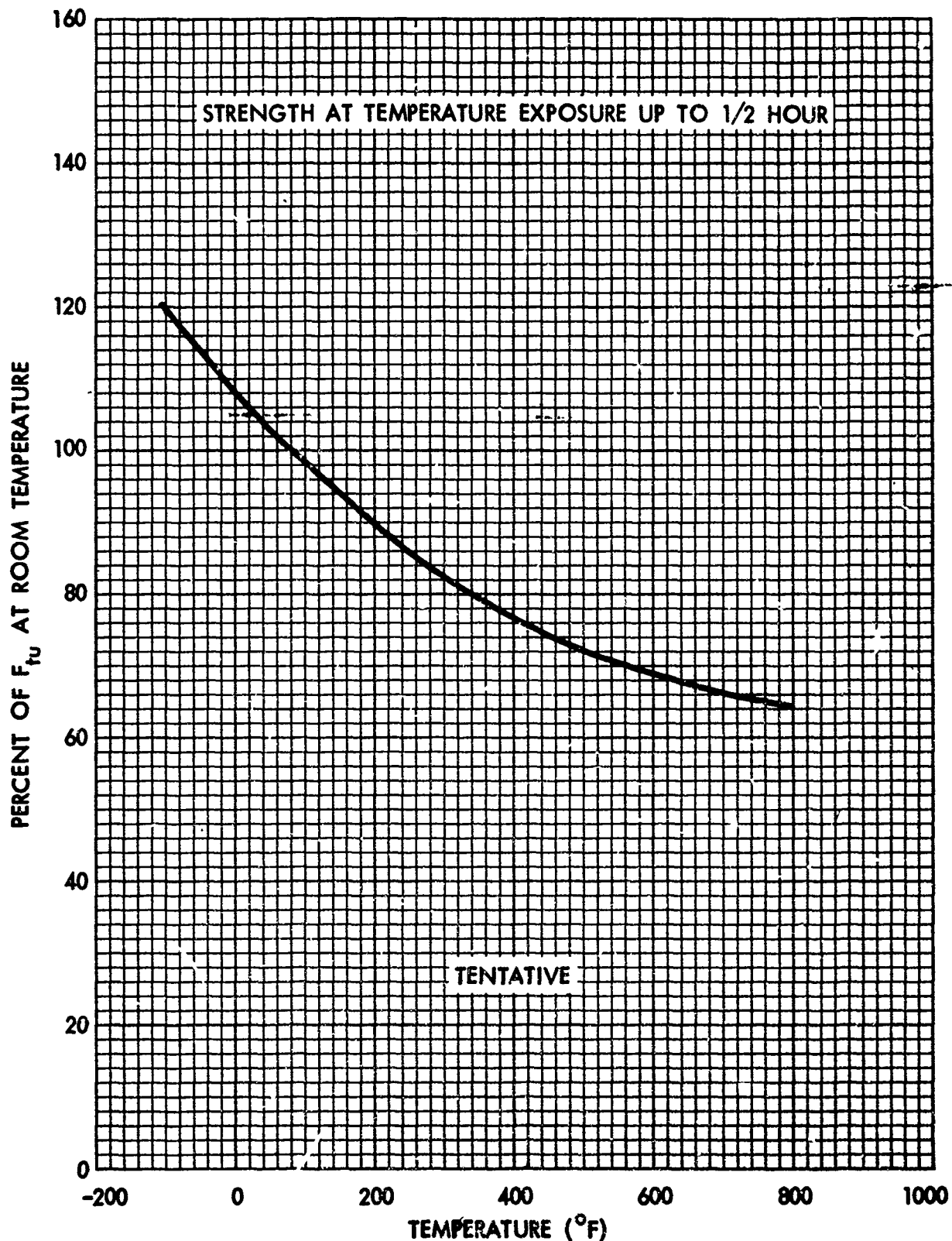

Figure 46. Effect of Temperature on the Ultimate Tensile Strength (F_{tu}) of Annealed Ti-6Al-4V Extrusions

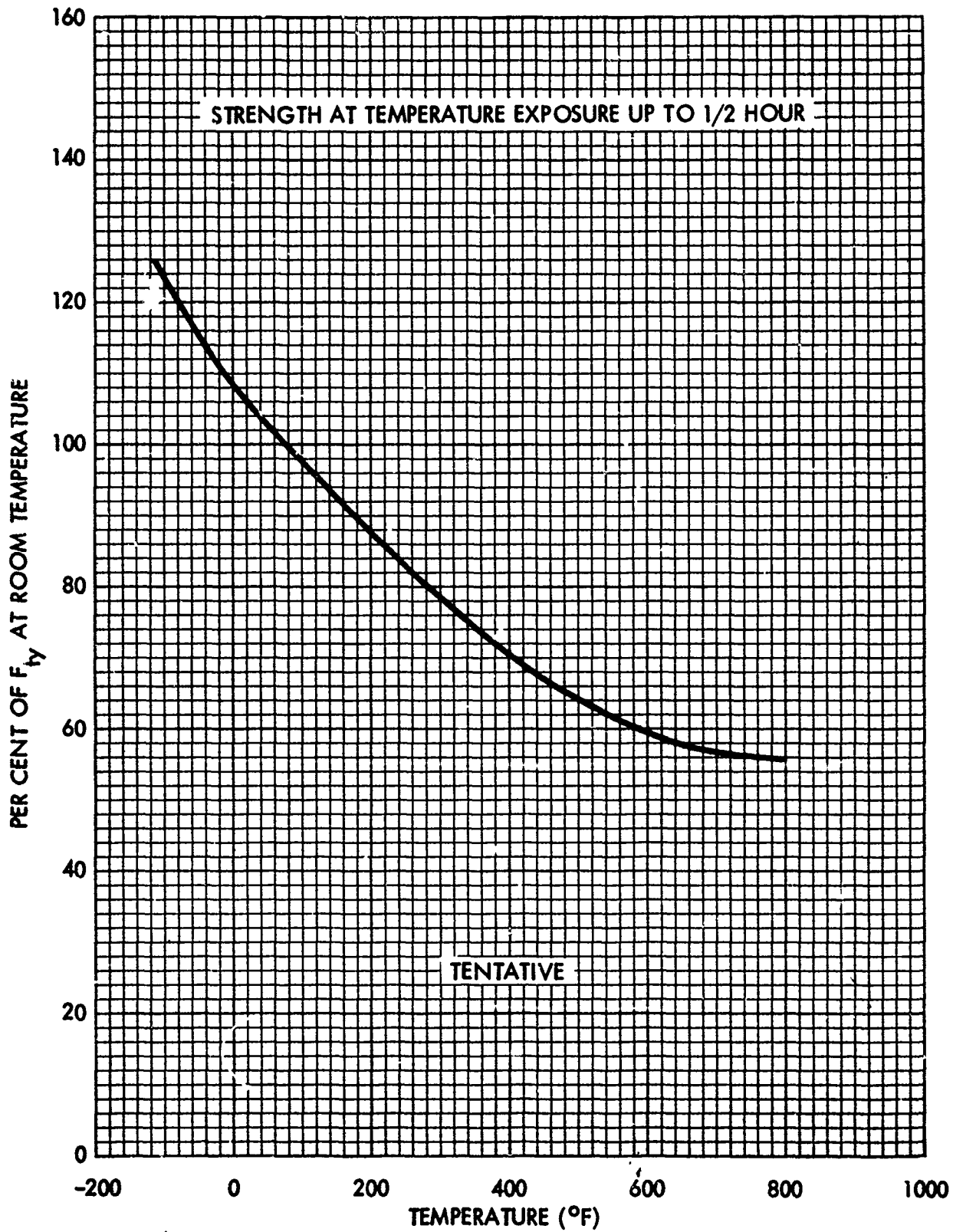

Figure 47. Effect of Temperature on the Tensile Yield Strength (F_{cy}) of Annealed Ti-6Al-4V Extrusions

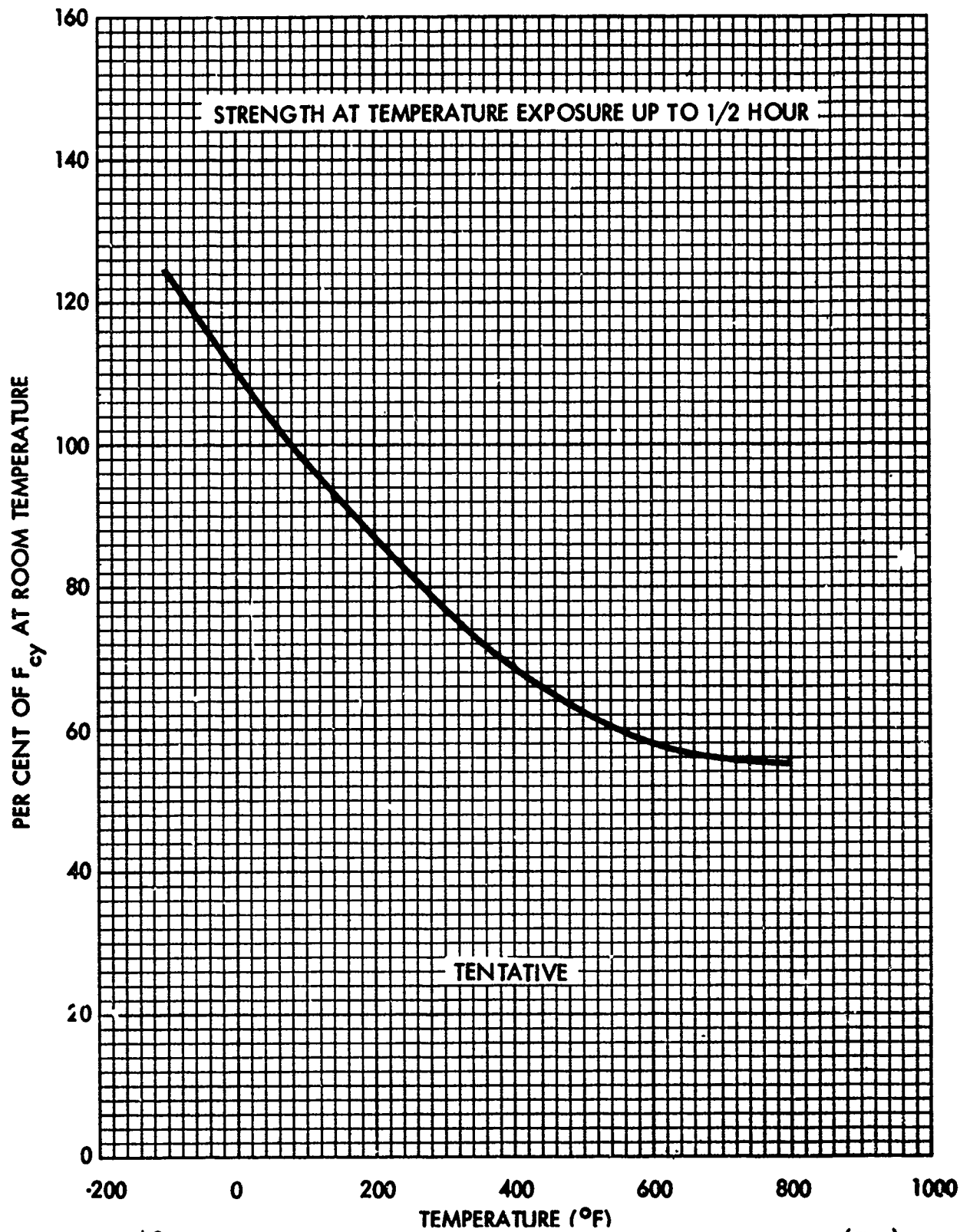

Figure 48. Effect of Temperature on the Compressive Yield Strength (F_{cy}) of Annealed Ti-6Al-4V Extrusions

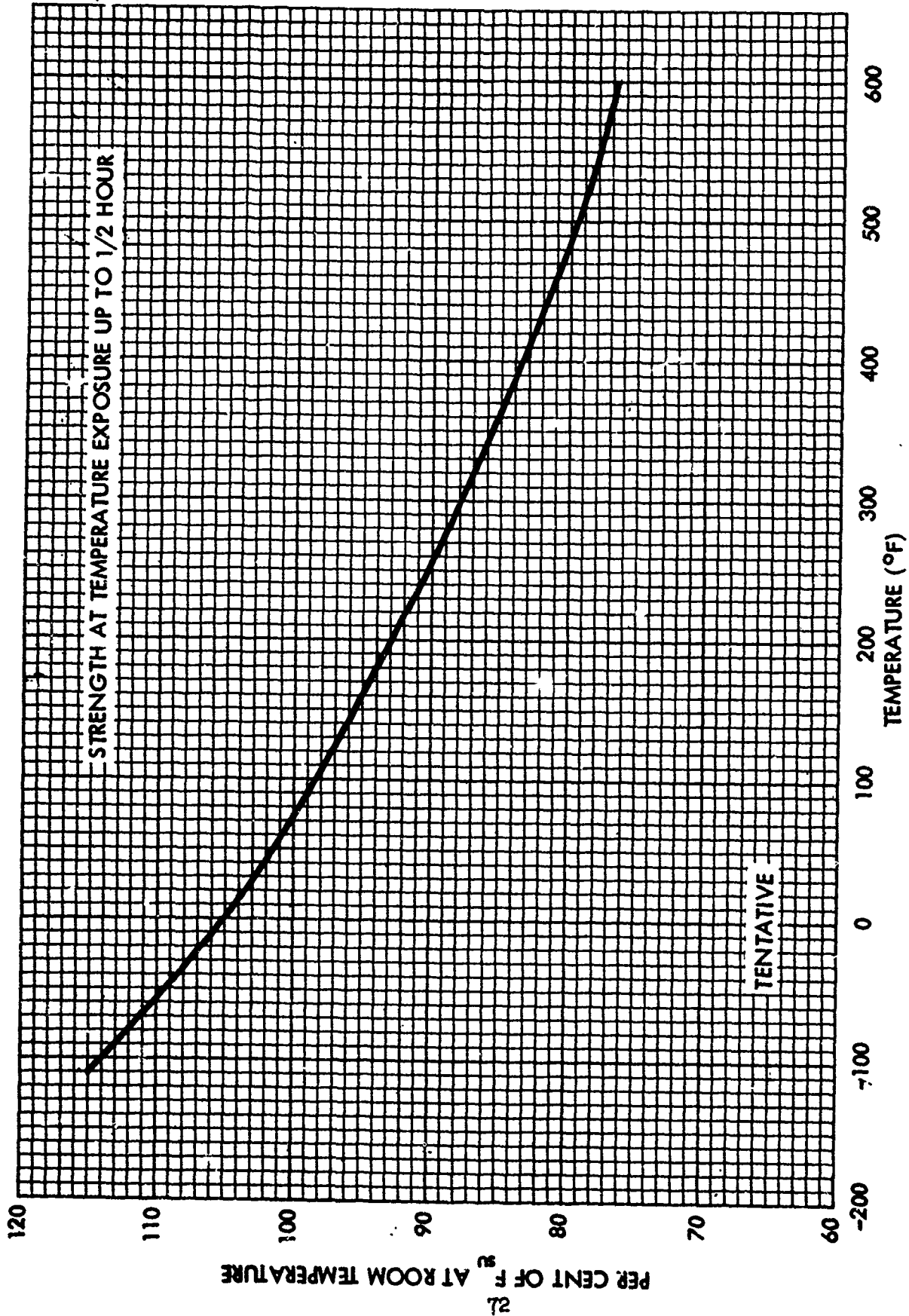

Figure 49. Effect of Temperature on the Ultimate Shear Strength (F_{su}) of Ti-6Al-4V Extrusions

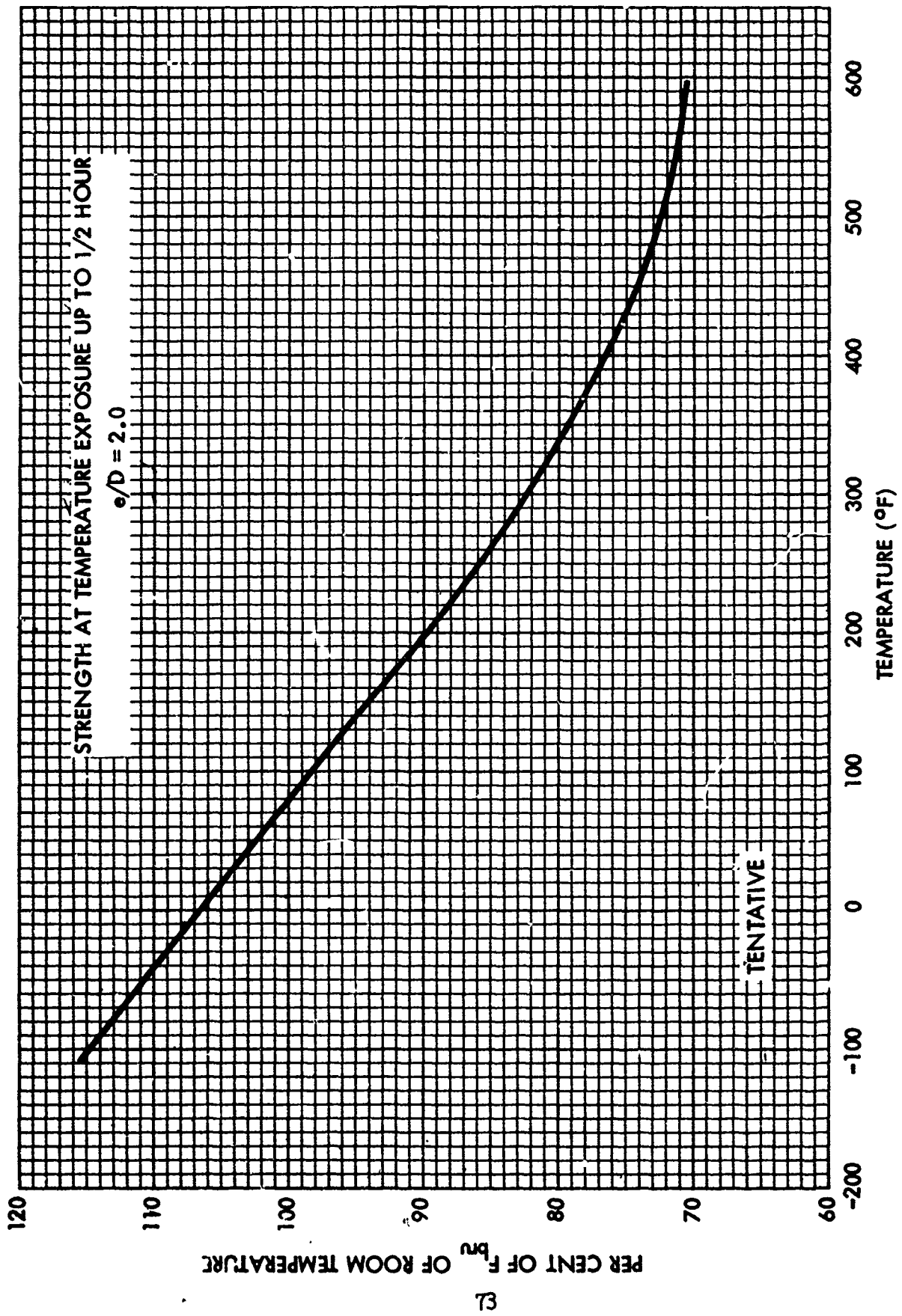

Figure 50. Effect of Temperature on the Ultimate Bearing Strength (F_{bru}) of TI-6Al-4V Extrusions

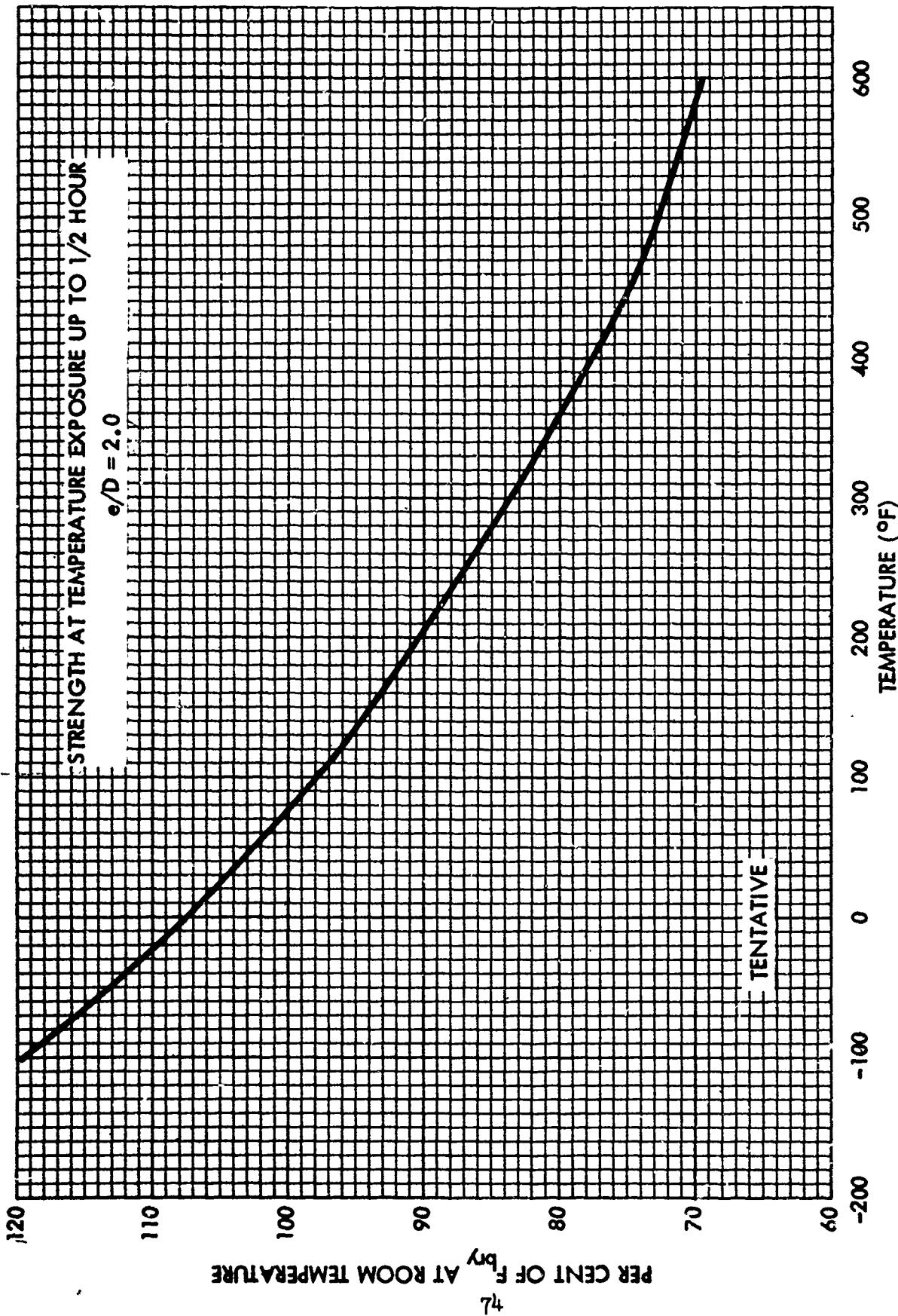

Figure 51. Effect of Temperature on the Bearing Yield Strength (F_{bry}) of Ti-6Al-4V Extrusions

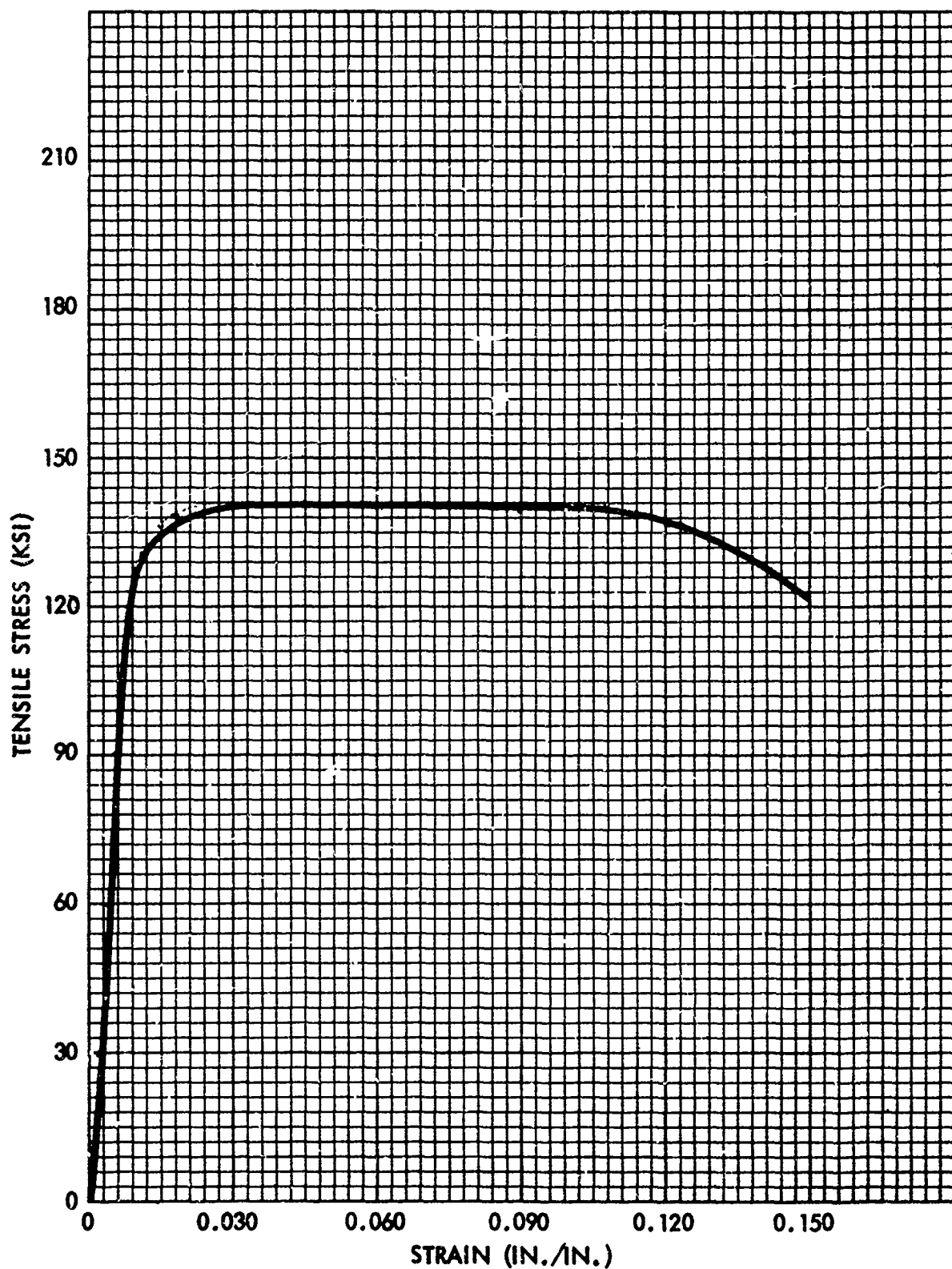

Figure 52. Typical Tensile Stress--Strain Curve Ti-6Al-4V
Extrusion at Room Temperature

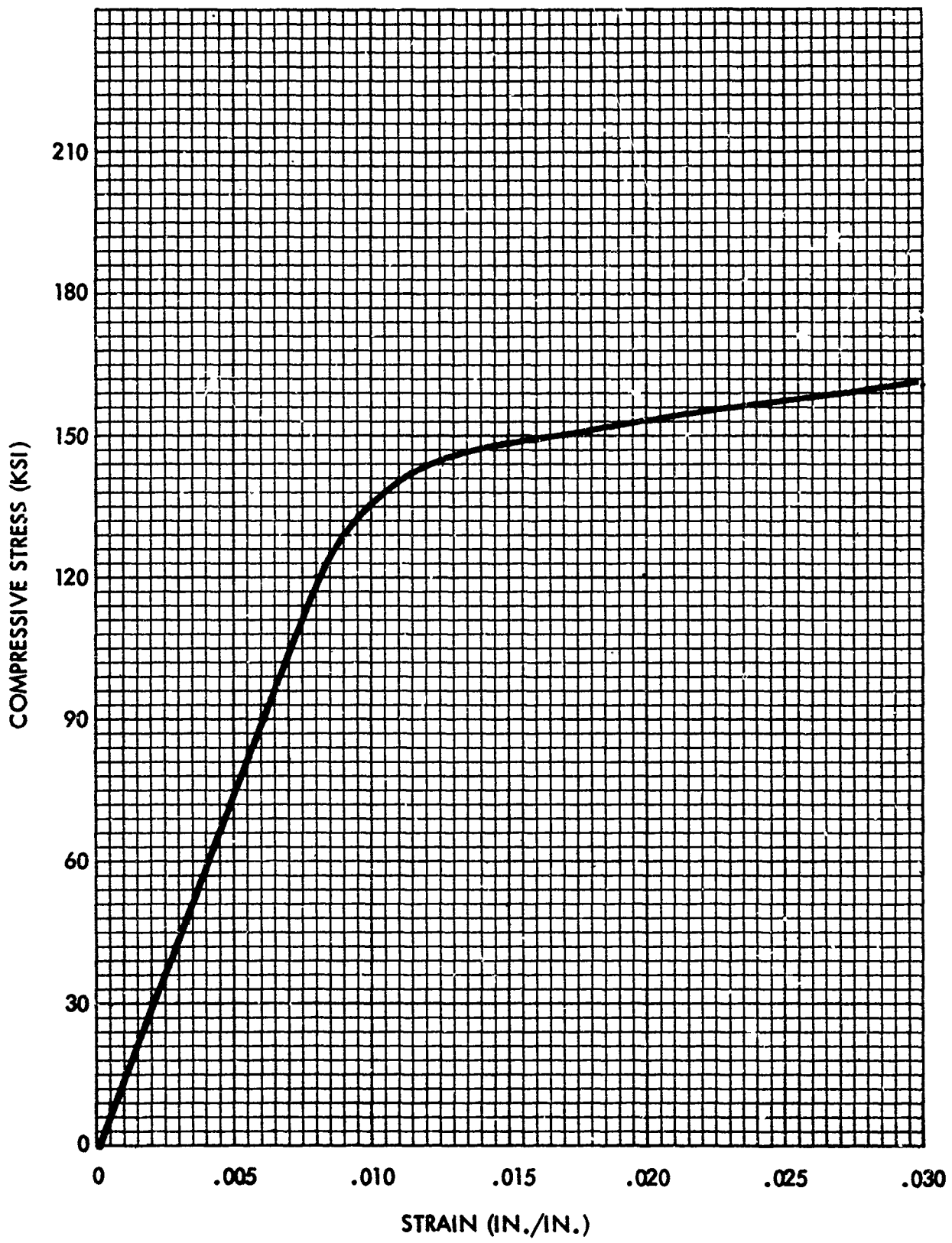

Figure 53. Typical Compressive Stress--Strain Curve
Ti-6Al-4V Extrusion at Room Temperature

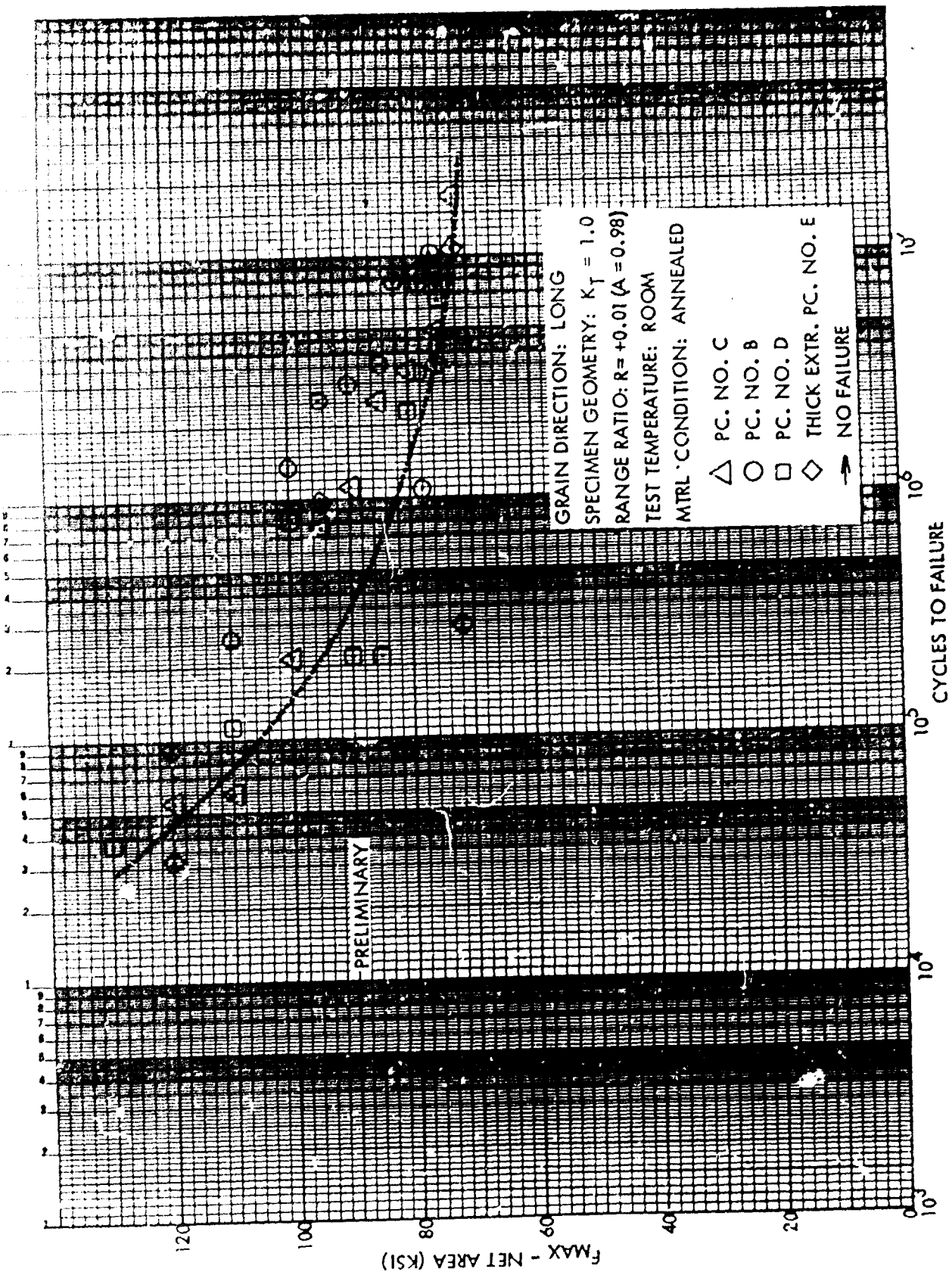

Figure 54. Typical S/N Fatigue Curve for $K_T = 1.0$, Ti-6Al-4V Extrusions at Room Temperature

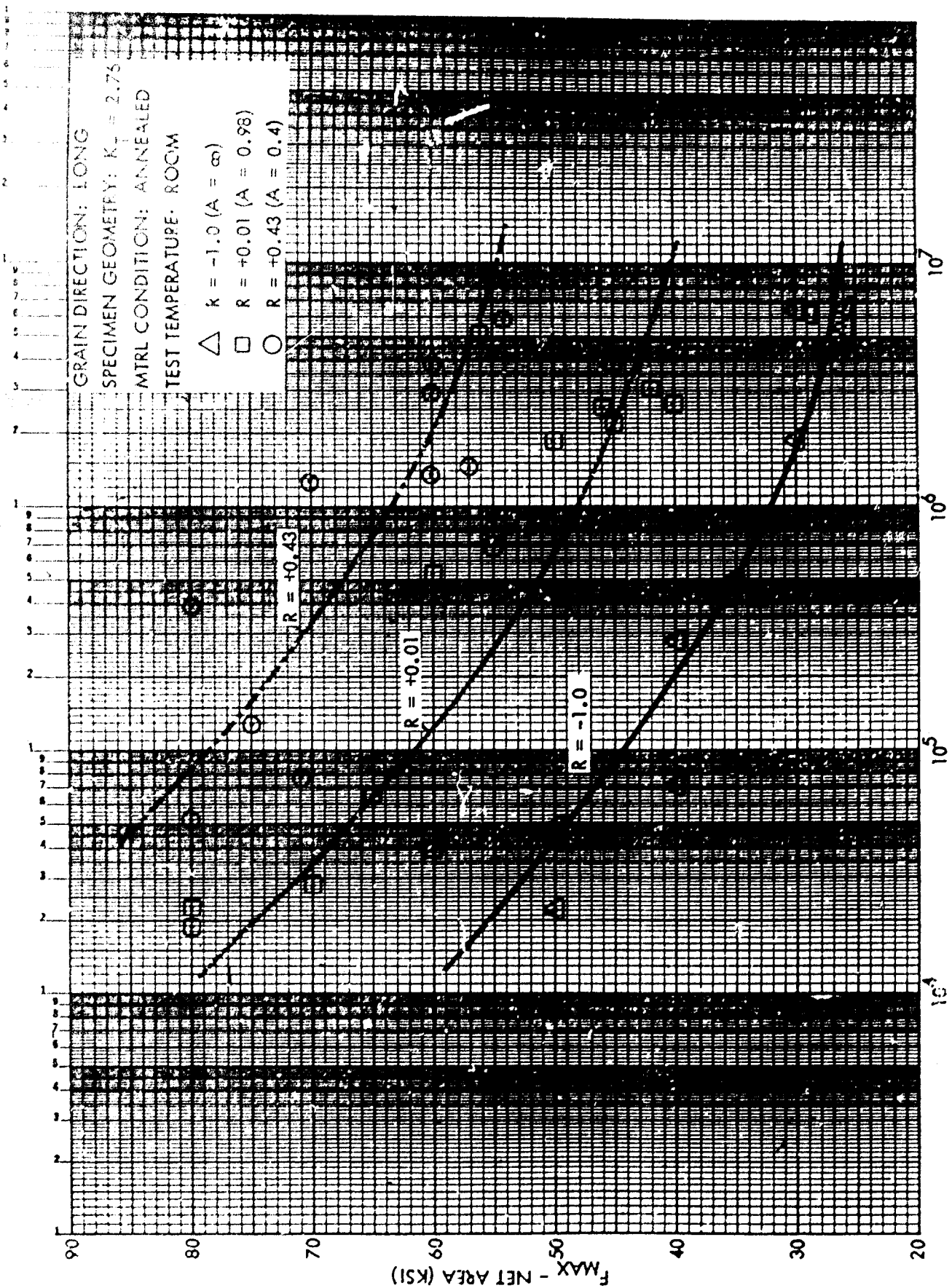

Figure 55. Typical S/N Fatigue Curves for $K_T = 2.76$ ($A = \infty$, $A = 0.98$, $A = 0.4$), Ti-6Al-4V Extrusions at Room Temperature

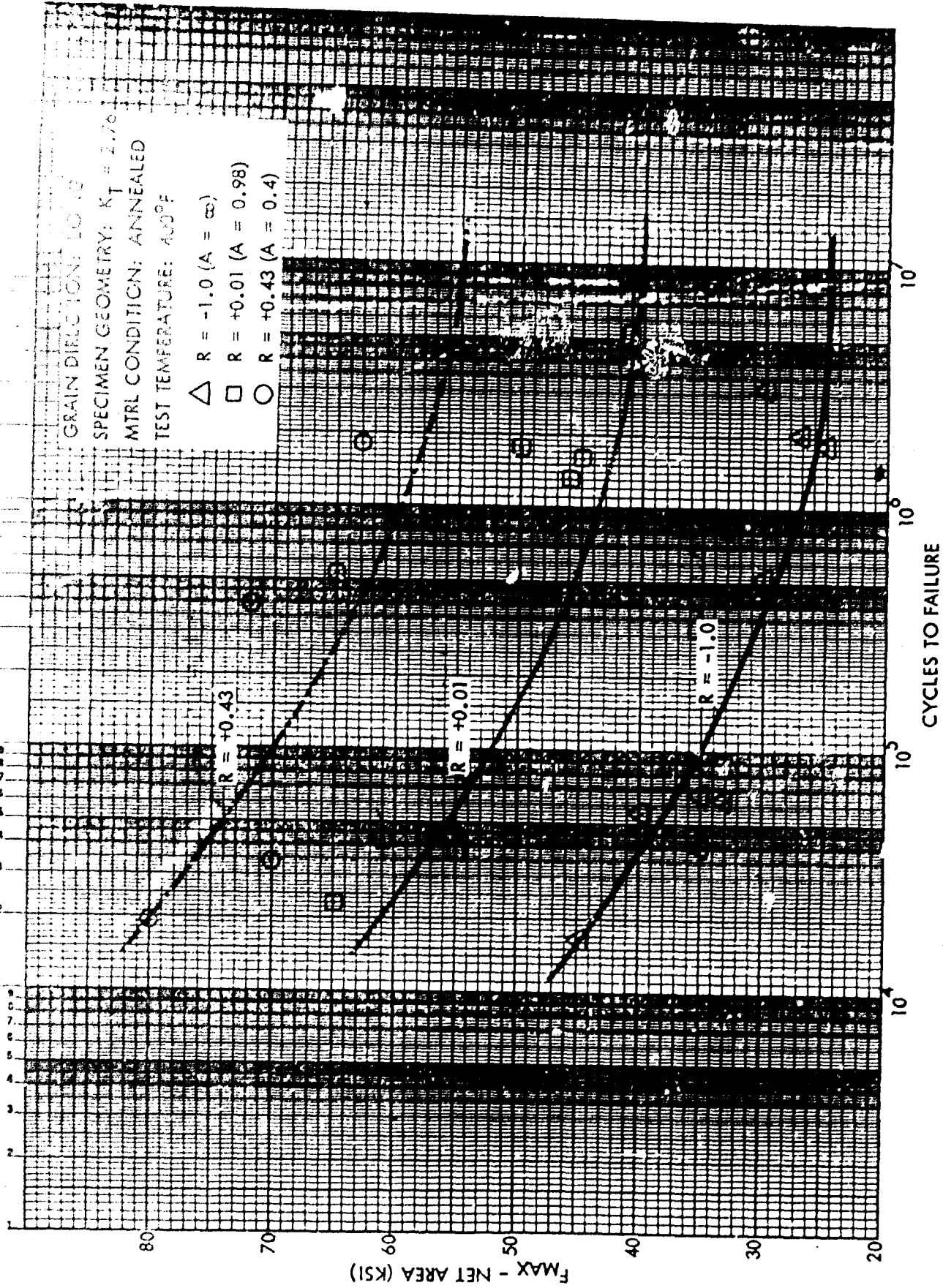

Figure 56. Typical S/N Fatigue Curves for K_T 2.76 ($A = \infty$, $A = 0.98$, $A = 0.4$), Ti-6Al-4V Extrusions at 400F

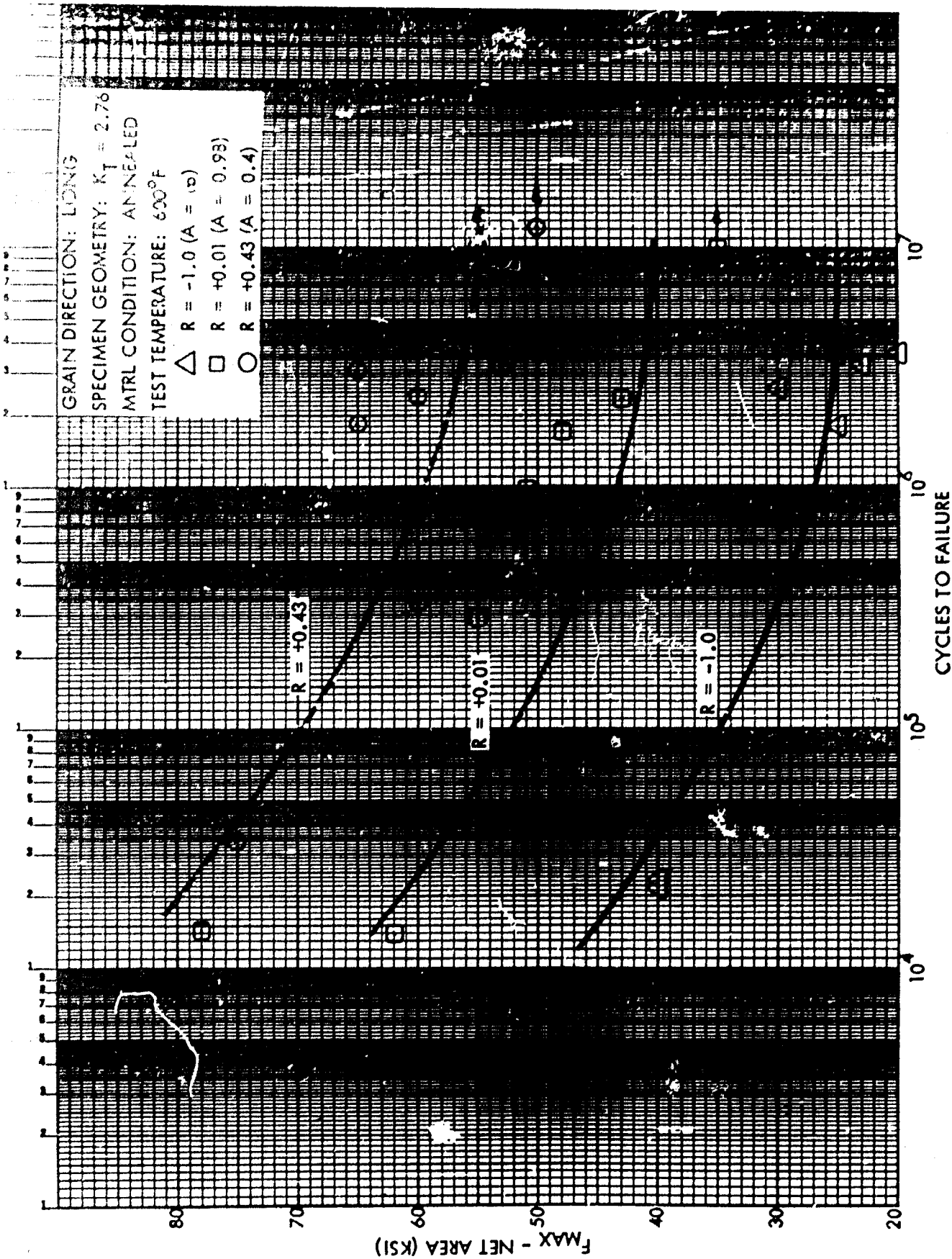

Figure 57. Typical S/N Fatigue Curves for K_T 2.76 ($A = \infty$, $A = 0.93$, $A = 0.4$), Ti-6Al-4V Extrusions at 600F

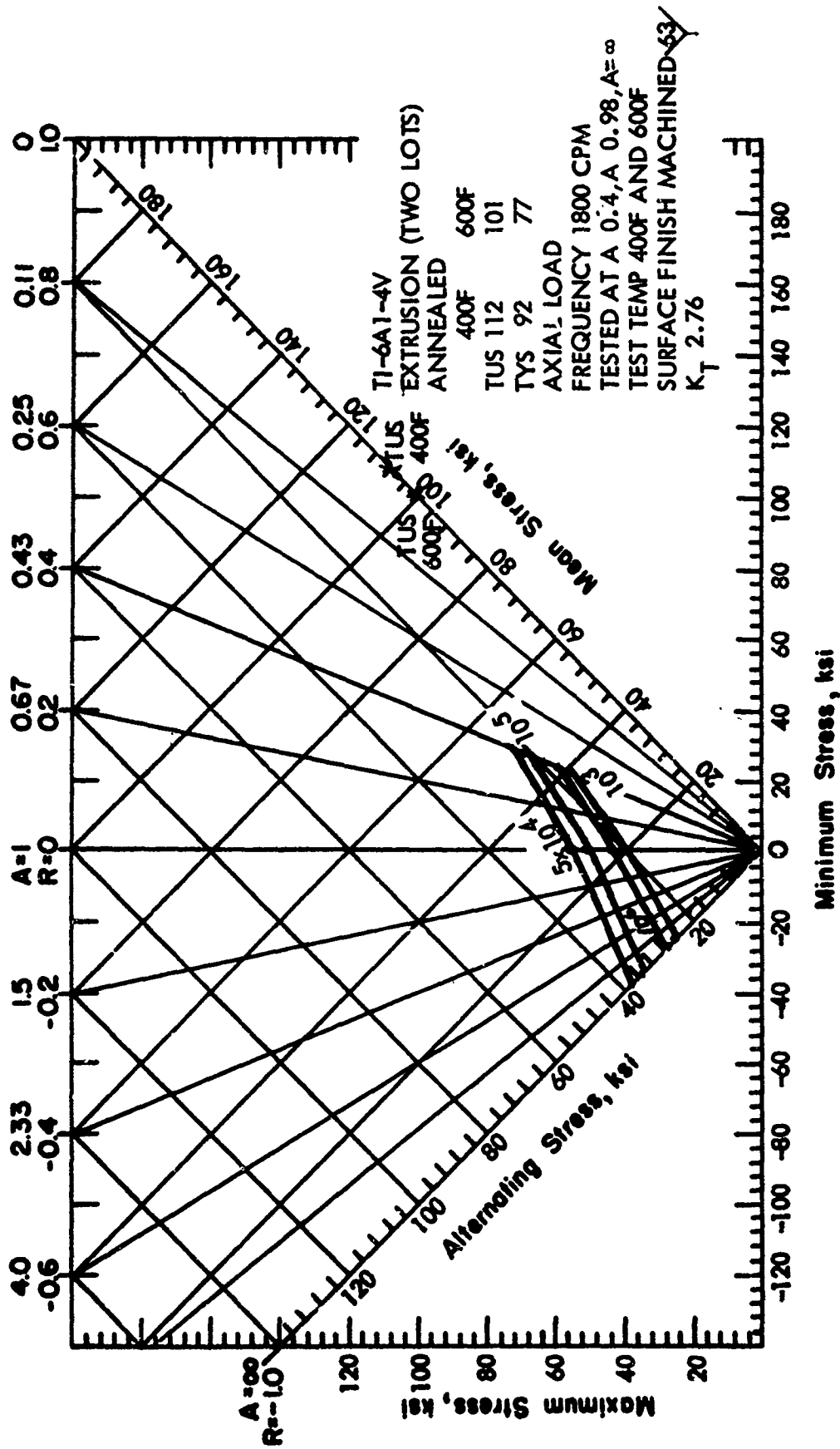

Figure 59. Constant-life Fatigue Diagram for Notched Ti-6Al-4V Extrusions at 400F and 600F

Table XV Tentative Design Mechanical and Physical Properties
of Ti-8Al-1Mo-1V Titanium Alloy (Extrusions)

| | |
|---|------------------------------------|
| Alloy | Ti-8Al-1Mo-1V |
| Form | Extruded Shapes, Rod and Bar |
| Condition | Annealed |
| Thickness or diameter, in. | |
| Basis | S |
| Mechanical properties: | |
| F_{tu} , ksi | 130 |
| L | 130 |
| IT | 130 |
| F_{ty} , ksi | 120 |
| L | 120 |
| IT | 120 |
| F_{cy} , ksi | (Typical values shown in Table V) |
| L | |
| IT | |
| F_{su} , ksi | (Typical values shown in Table XI) |
| F_{br} , ksi: | |
| ($e/D = 1.5$) | (Typical values shown in Table IX) |
| ($e/D = 2.0$) | |
| F_{br} , ksi: | |
| ($e/D = 1.5$) | (Typical values shown in Table X) |
| ($e/D = 2.0$) | |
| e, per cent: | |
| In 2 in. | 10 |
| In 4 D | 10 |
| E, 10^6 psi | 17.6 |
| E_c , 10^6 psi | |
| G, 10^6 psi | |
| μ | |
| Physical properties: | |
| ω , lb/in. ³ | 0.158 |
| C, Btu/(lb)(F) | |
| K, Btu/[(hr)(ft ²)(F)/ft] | |
| α , 10^{-6} in./in./F | |

- (2) Effect of temperature on ultimate tensile strength at temperature is shown in Figure 60. Effect of temperature on tensile yield strength is shown in Figure 61. Effect of temperature on compressive yield strength is shown in Figure 62. Effect of temperature on shear and on bearing properties are shown in Figures 63, 64, and 65.
- (3) Stress-strain curves in tension and compression (typical curves) are shown in Figures 66 and 67.
- (4) S/N diagrams showing typical room temperature and elevated temperature characteristics of smooth and of notched specimens are shown in Figures 68, 69, 70, and 71, modified Goodman diagrams in Figures 72 and 73.
- (5) Discussion of fracture toughness and of delayed failure characteristics is included in Section IV.
- (6) Discussion of creep characteristics is included in Section IV.

Ti-6Al-6V-2Sn TENTATIVE DESIGN PROPERTIES

- (1) Tentative room temperature design mechanical properties are summarized in Table XVI.
- (2) Effect of temperature on ultimate tensile strength at temperature is shown in Figure 74. Effect of temperature on tensile yield strength is shown in Figure 75. Effect of temperature on compressive yield strength is shown in Figure 76. Effect of temperature on shear and on bearing properties is shown in Figures 77, 78, and 79.
- (3) Stress-strain curves in tension and compression (typical curves) are shown in Figures 80 and 81.
- (4) S/N diagrams showing typical room temperature and elevated temperature characteristics of smooth and of notched specimens are shown in Figures 82, 83, 84 and 85, modified Goodman diagrams in Figures 86 and 87.
- (5) Fracture toughness and delayed failure characteristics are discussed in Section IV.
- (6) Creep characteristics are discussed in Section IV.

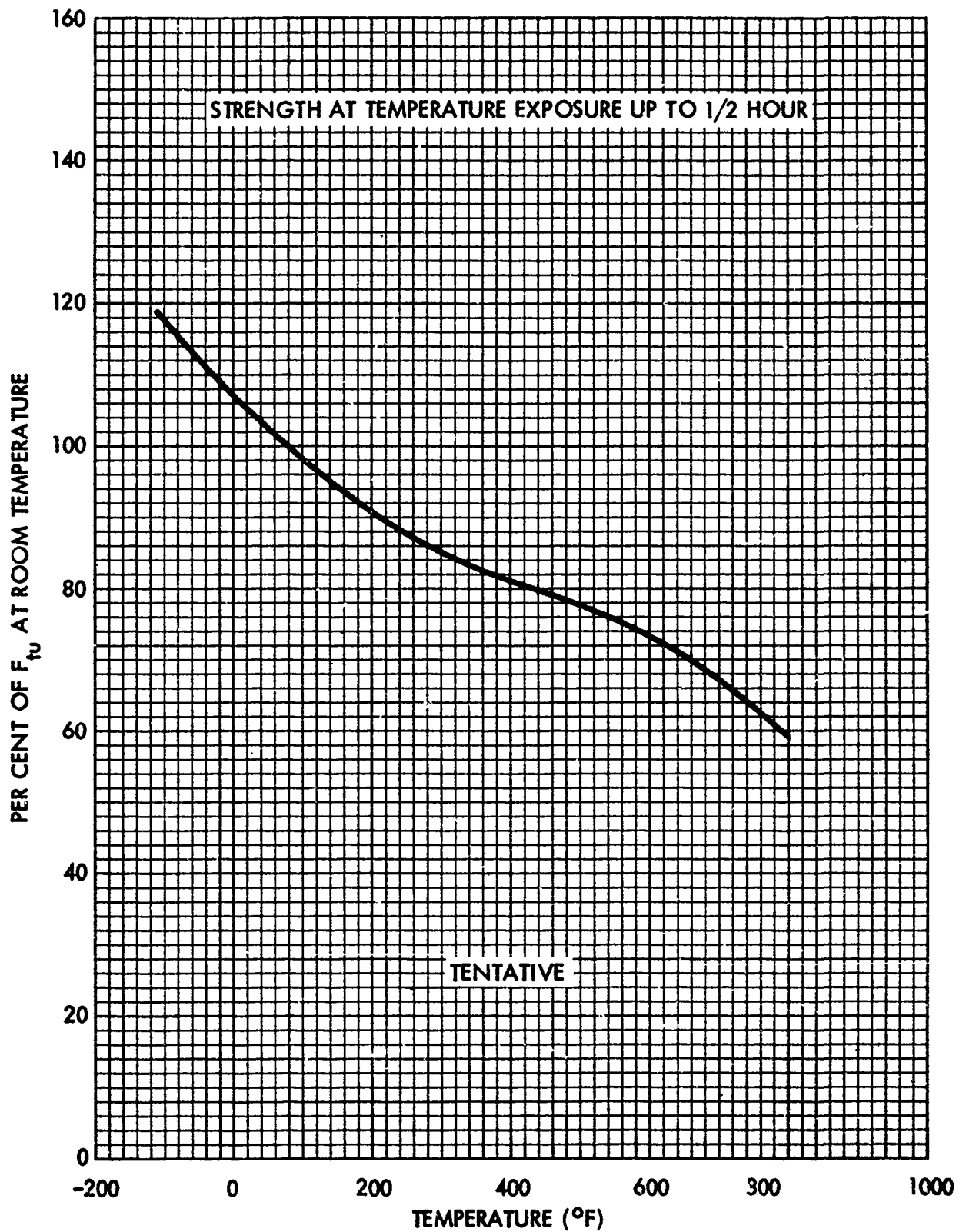

Figure 60. Effect of Temperature on the Ultimate Tensile Strength (F_{tu}) of Annealed Ti-8Al-1Mo-1V Extrusions

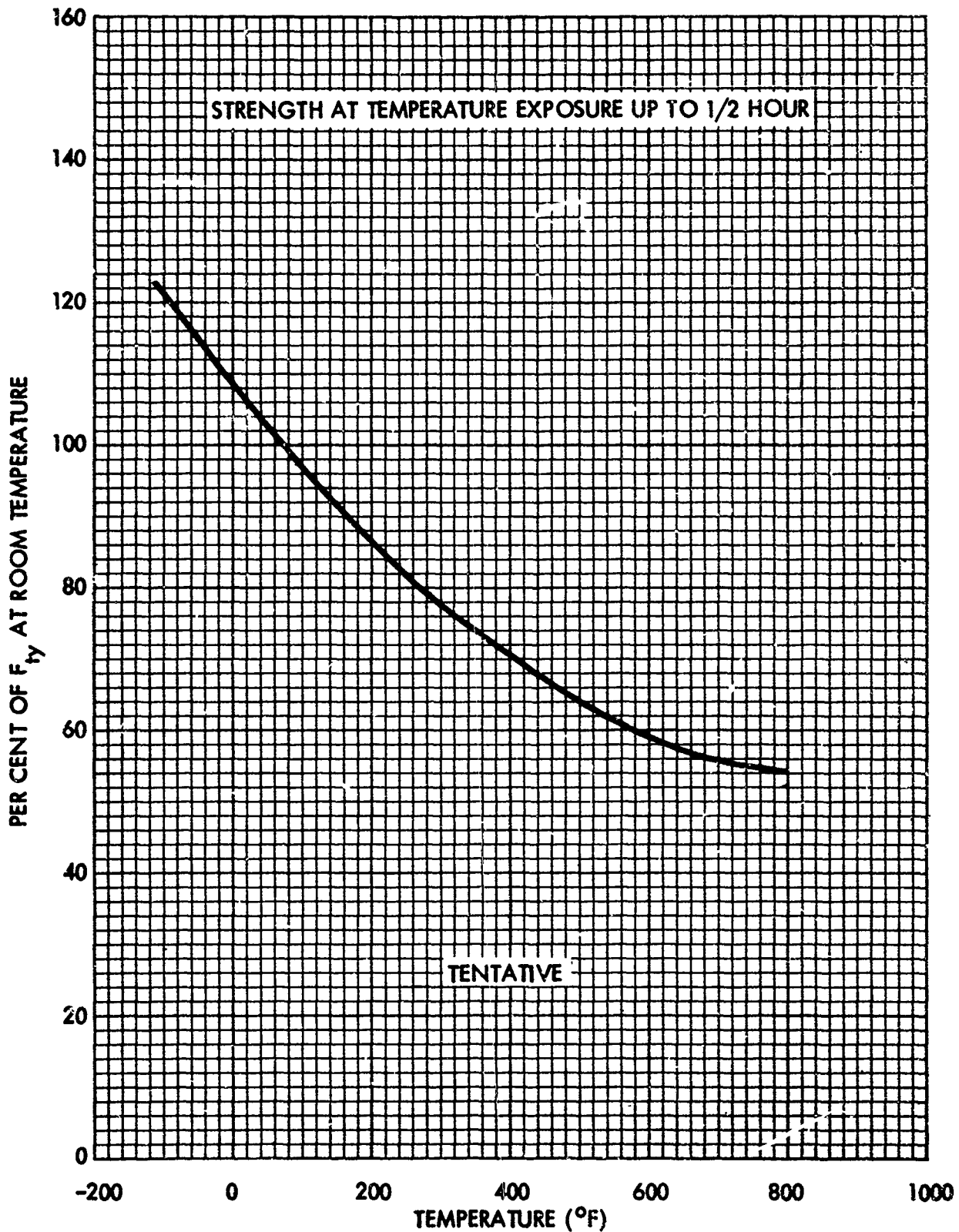

Figure 61. Effect of Temperature on the Tensile Yield Strength (F_{ty}) of Annealed Ti-8Al-1Mo-1V Extrusions

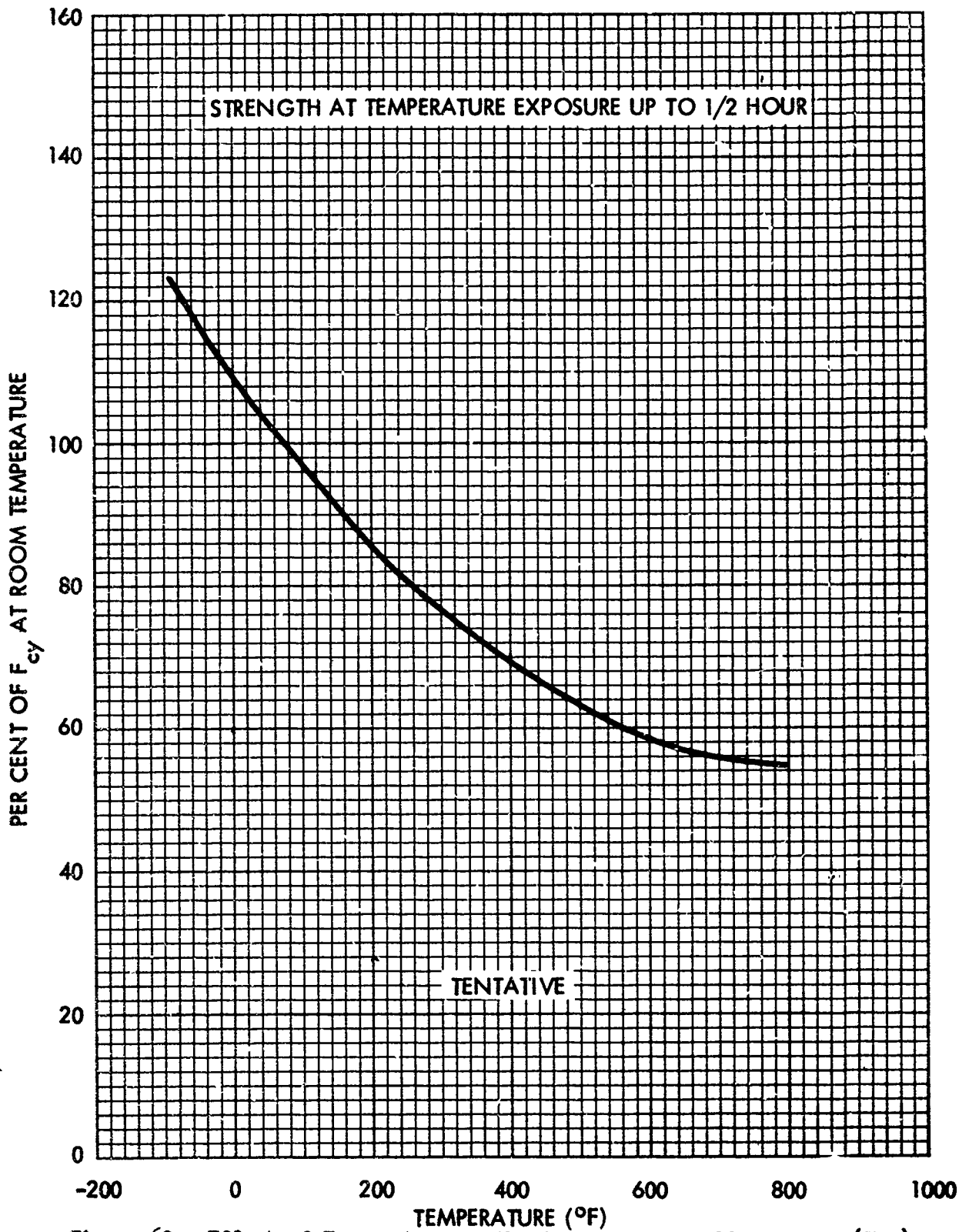

Figure 62. Effect of Temperature on the Compressive Yield Strength (F_{cy}) of Annealed Ti-8Al-1Mo-1V Extrusions

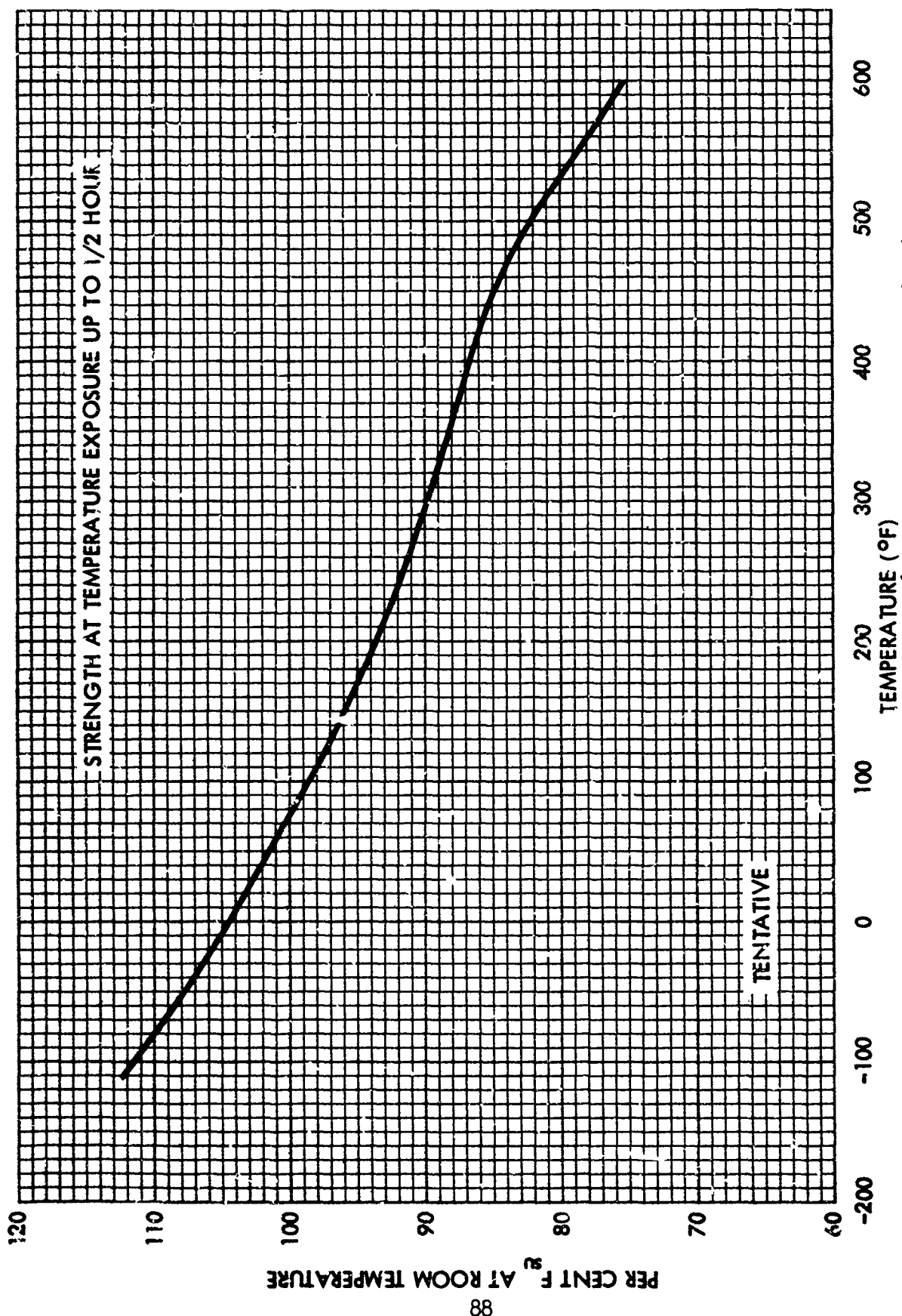

Figure 63. Effect of Temperature on the Ultimate Shear Strength (F_{su}) of Ti-8Al-1Mo-1V Extrusions

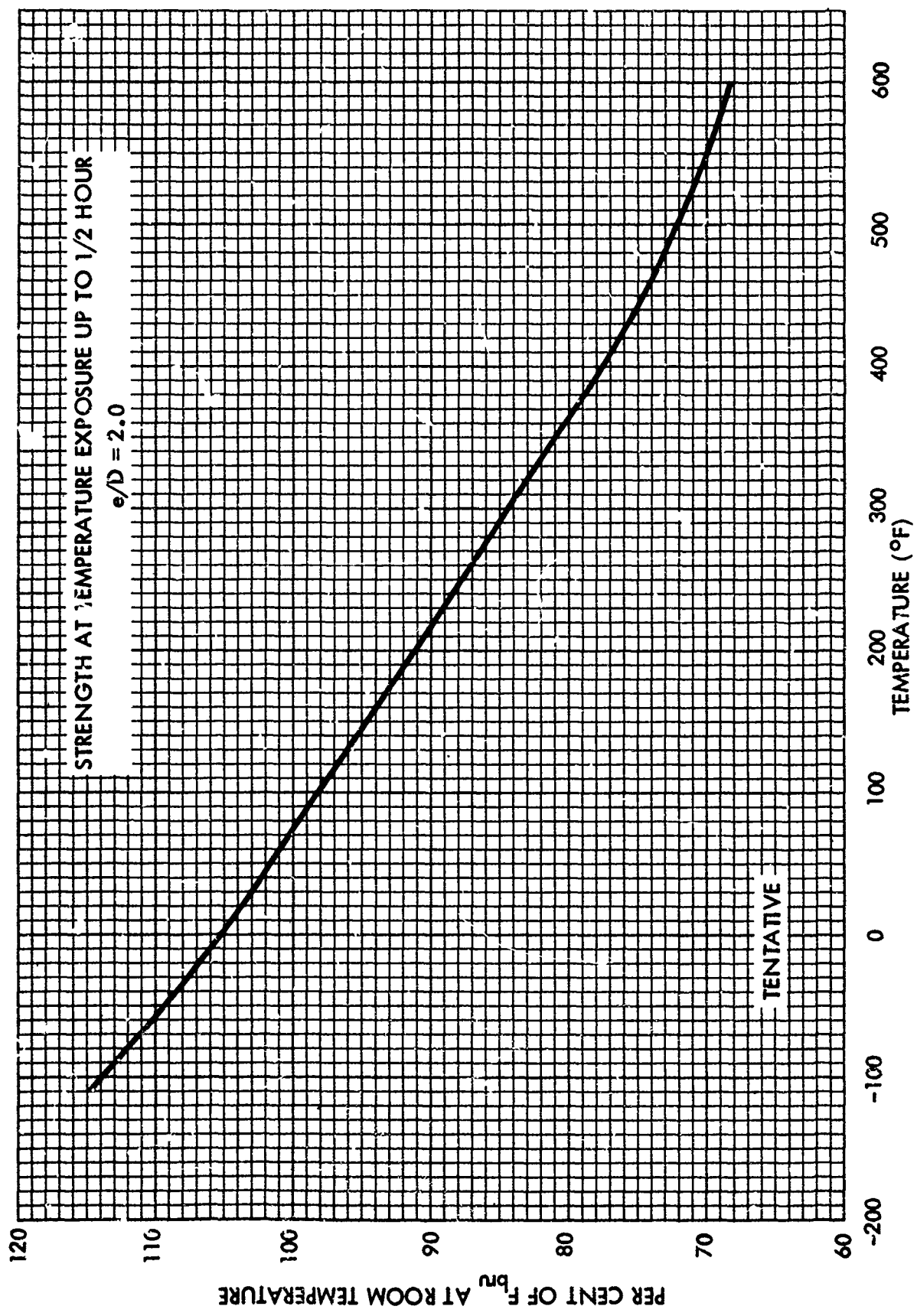

Figure 64. Effect of Temperature on the Ultimate Bearing Strength (F_{bru}) of Ti-8Al-1Mo-1V Extrusions

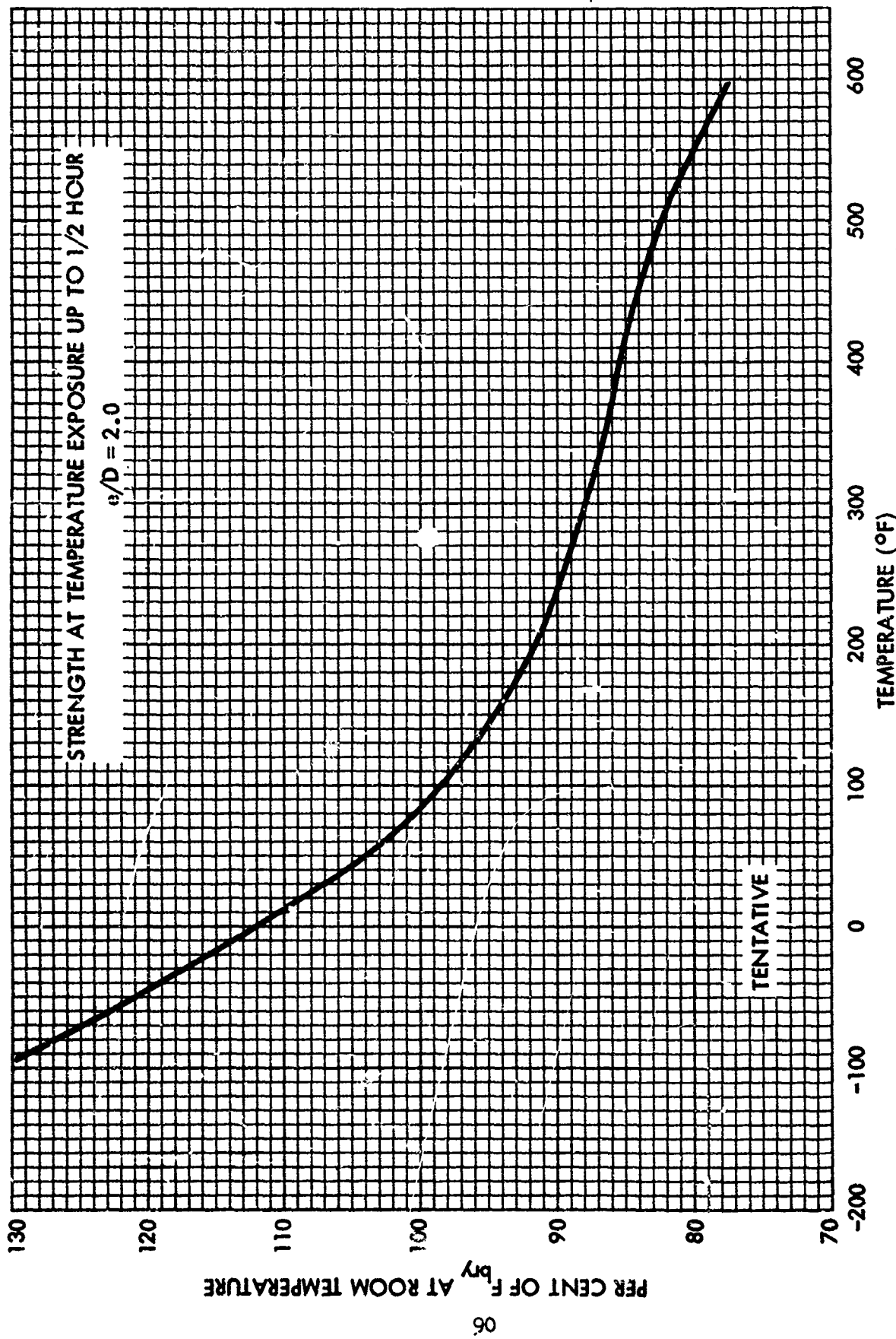

Figure 65. Effect of Temperature on the Bearing Yield Strength (F_{bry}) of Ti-8Al-1Mo-1V Extrusions

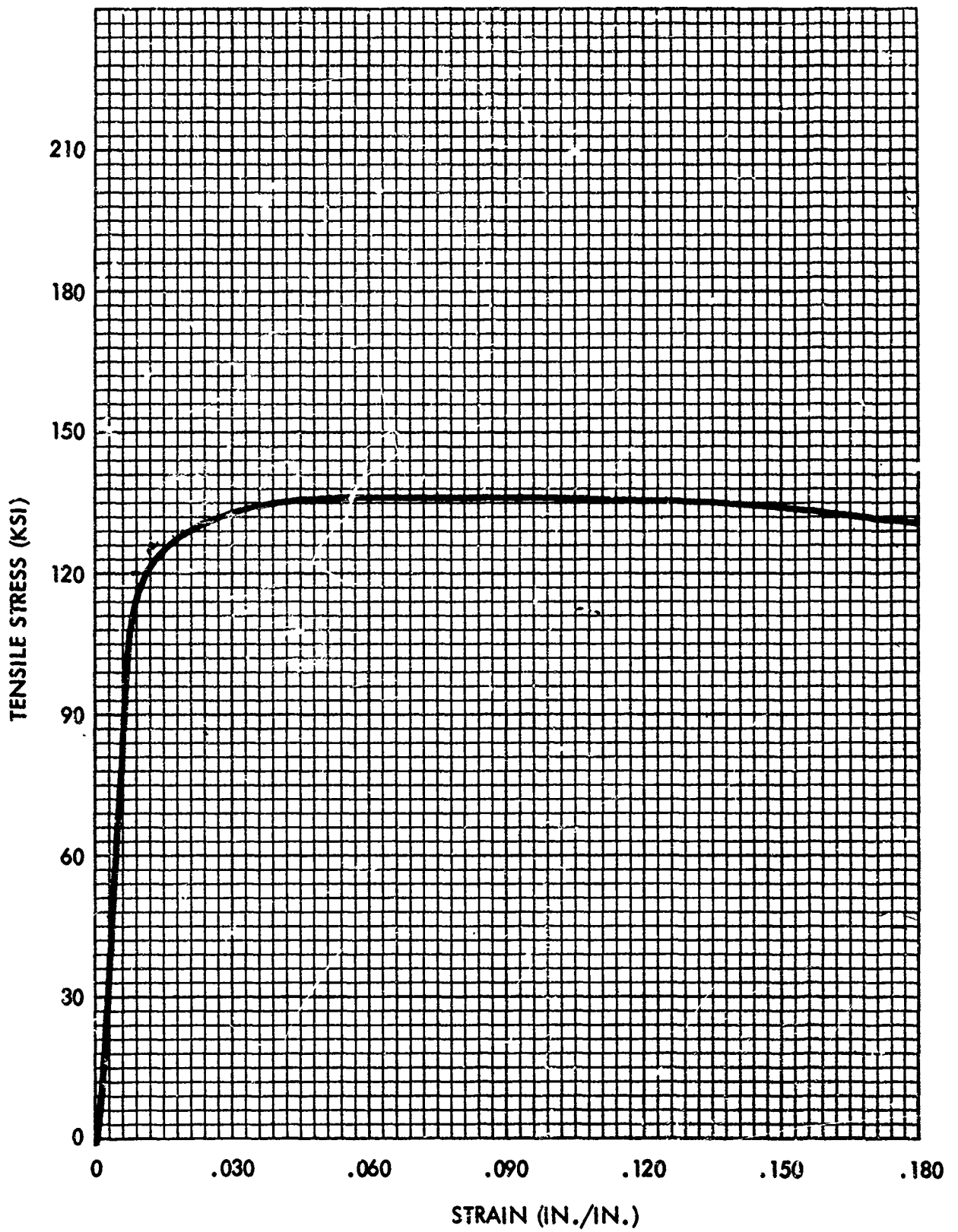

Figure 66. Typical Tensile Stress--Strain Curve Ti-3Al-1Mo-1V
Extrusion at Room Temperature

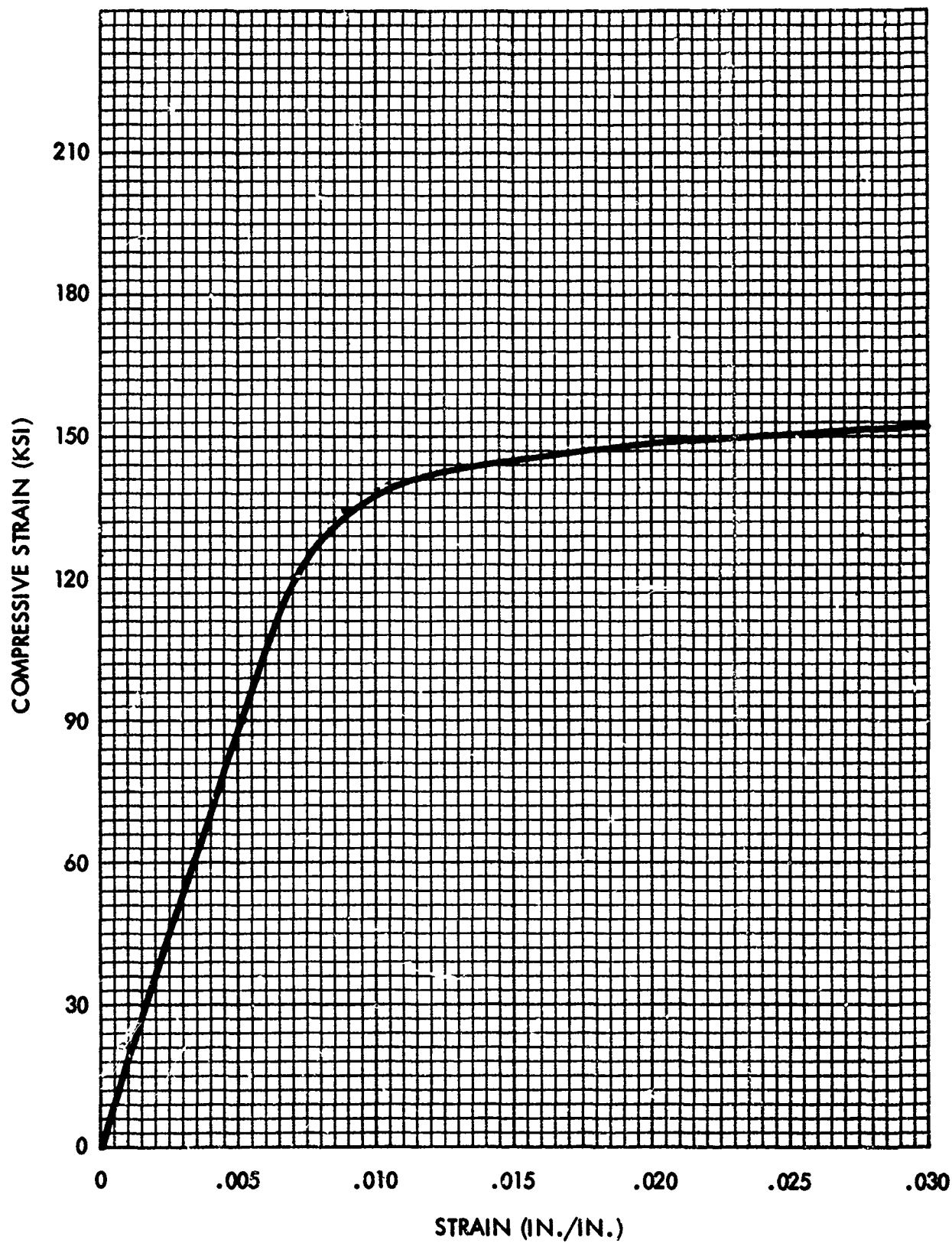
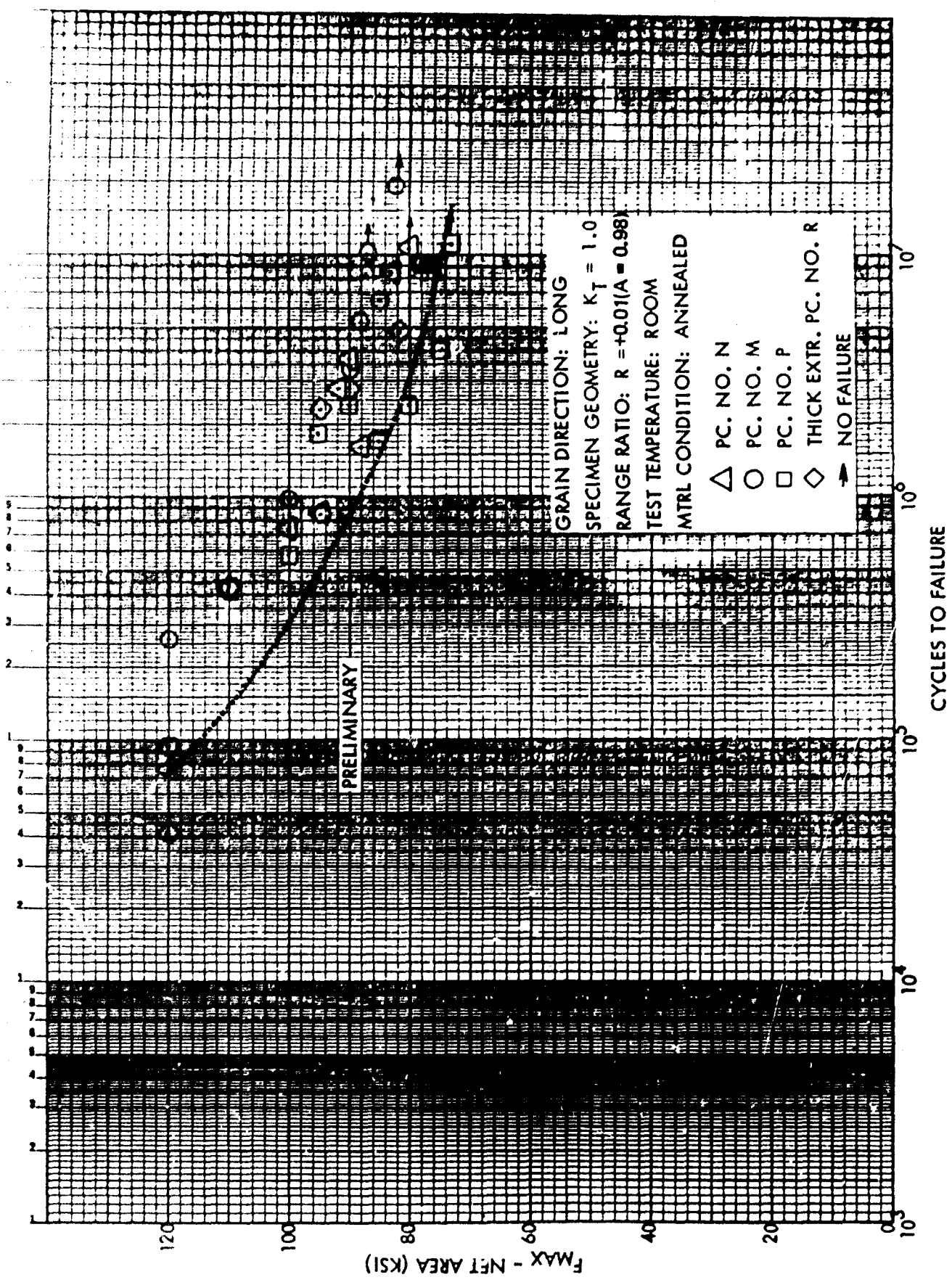

Figure 67. Typical Compressive Stress--Strain Curve
Ti-8Al-1Mo-1V Extrusions at Room Temperature



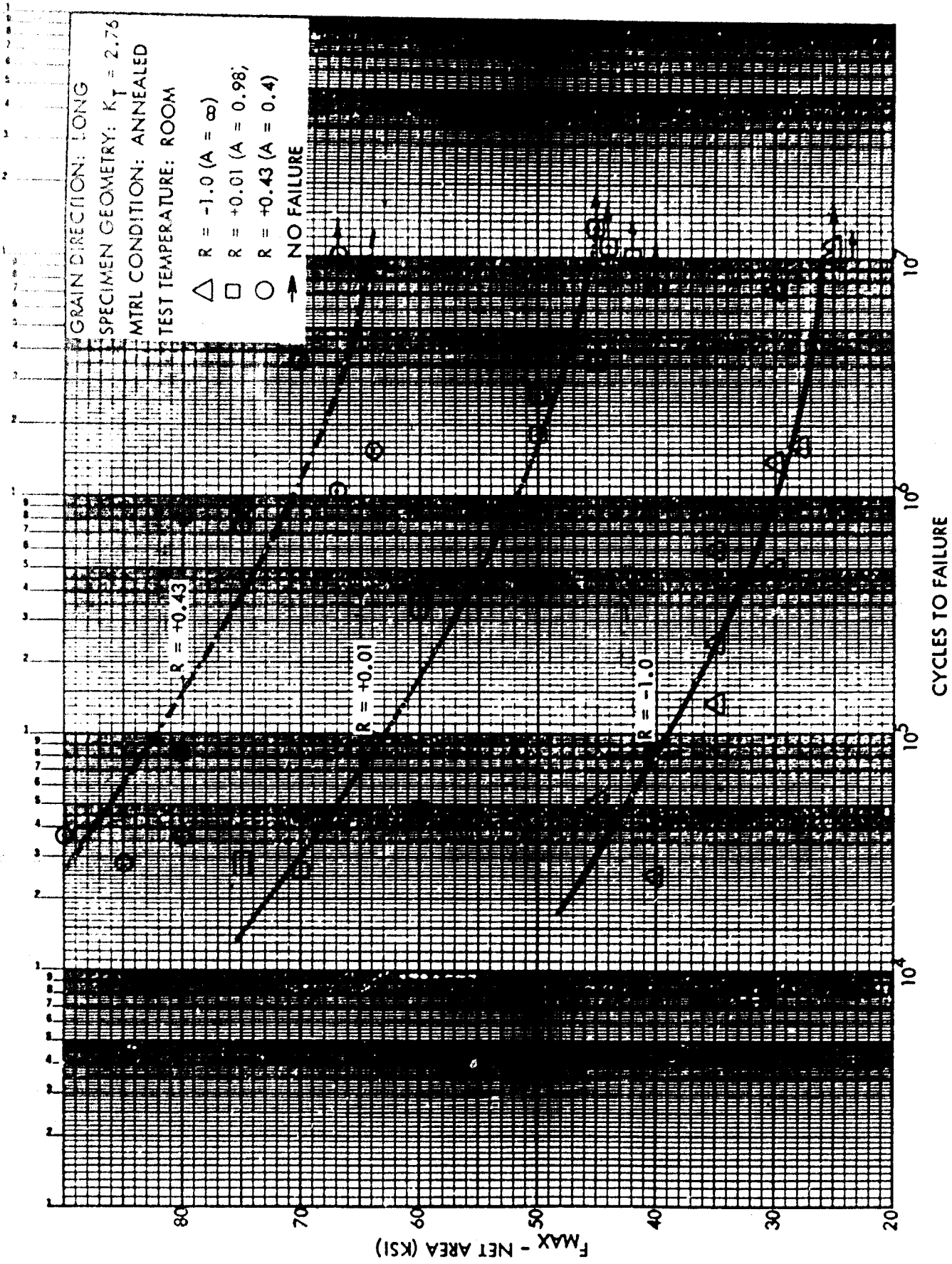

Figure 69. Typical S/N Fatigue Curves for $K_T = 2.76$ ($A = \infty$, $A = 0.98$, $A = 0.4$) Ti-8Al-1Mo-1V Extrusions at Room Temperature

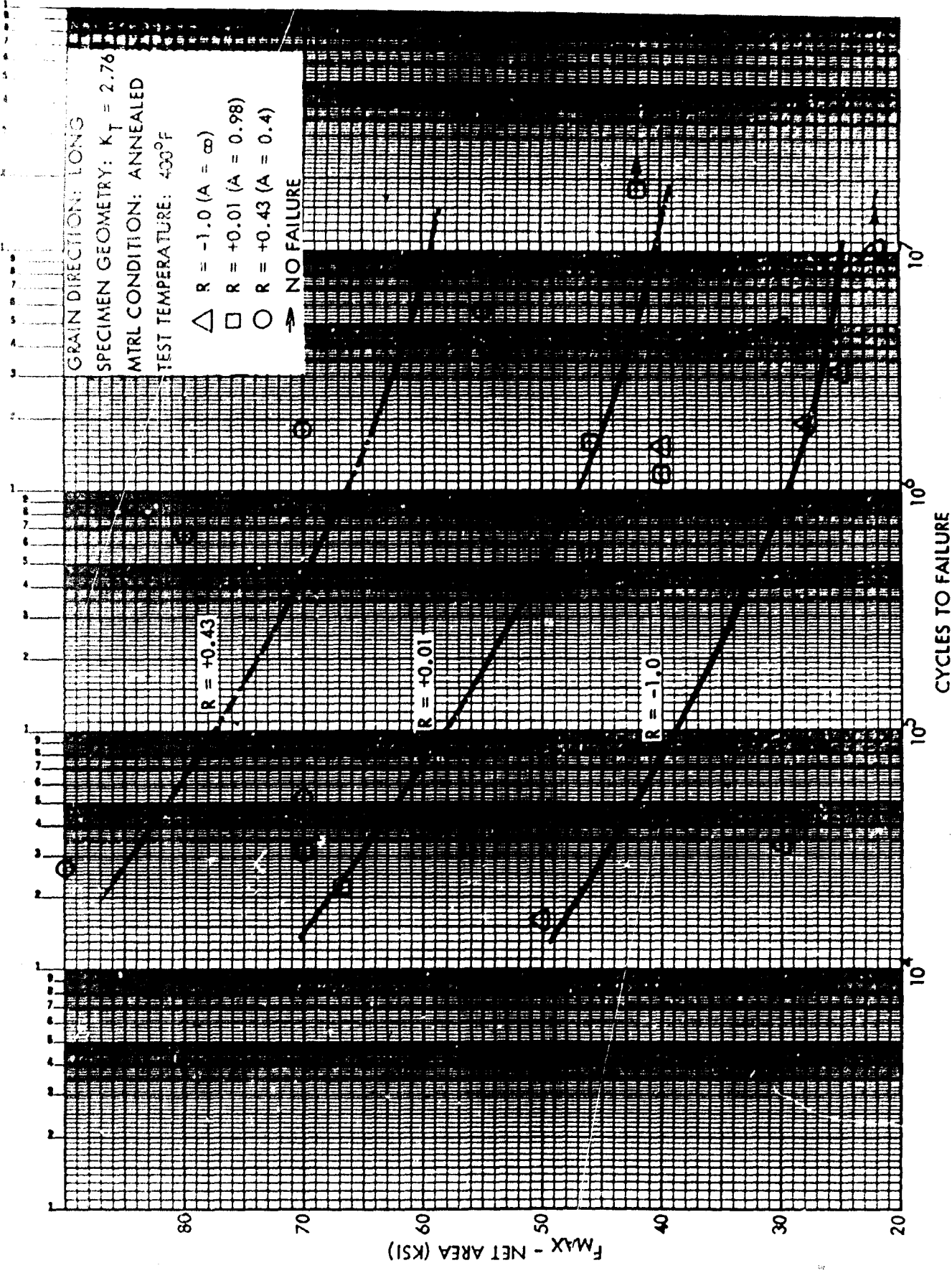

Figure 70. Typical S/N Fatigue Curves for $K_T = 2.76$ (A = ∞ , A = 0.98, A = 0.4) Ti-8Al-1Mo-1V Extrusions at 400F

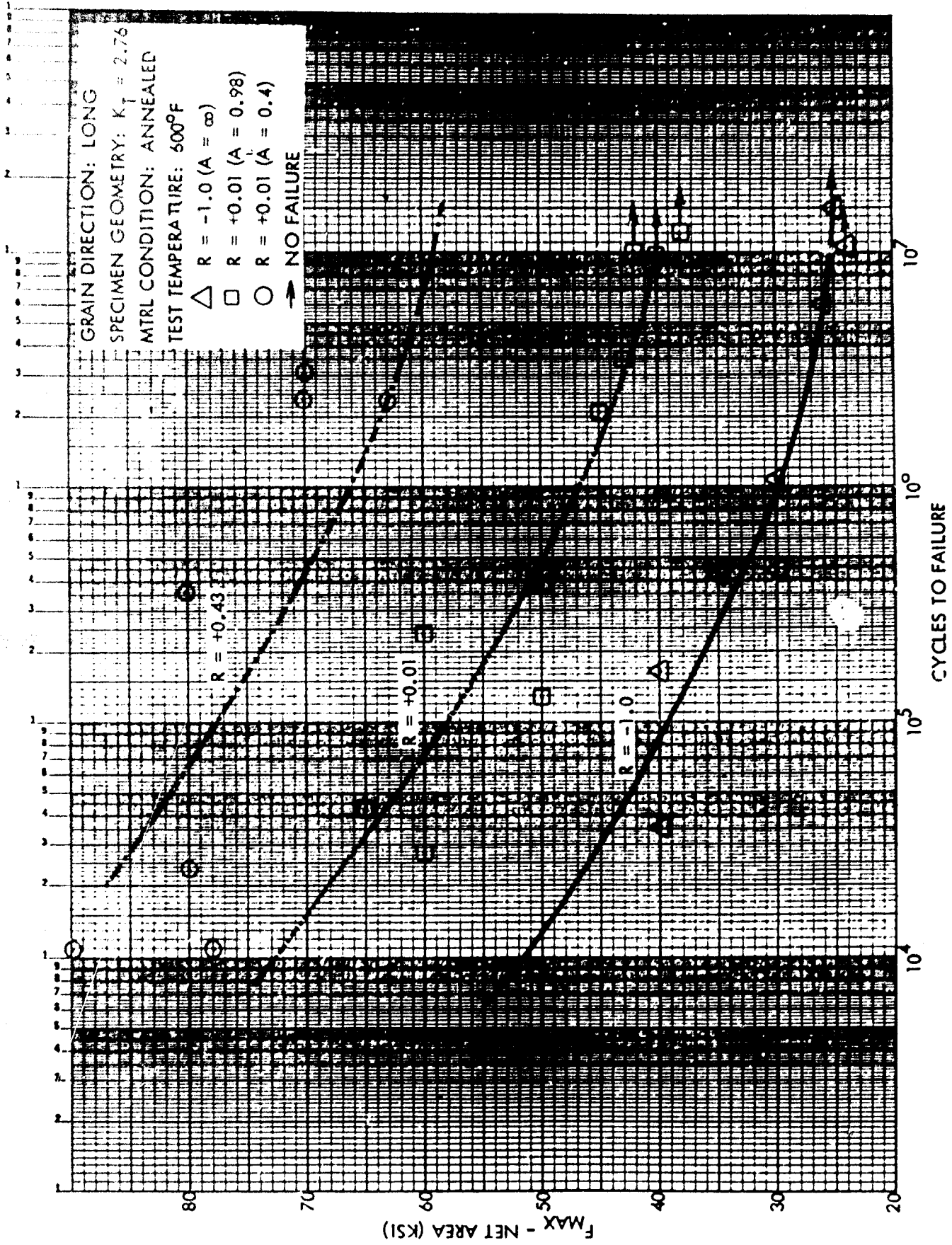

Figure 71. Typical S/N Fatigue Curves for $K_T = 2.76$ (A = ∞ , A = 0.98, A = 0.4) T1-8AL-1Mo-1V Extrusions at 600°F

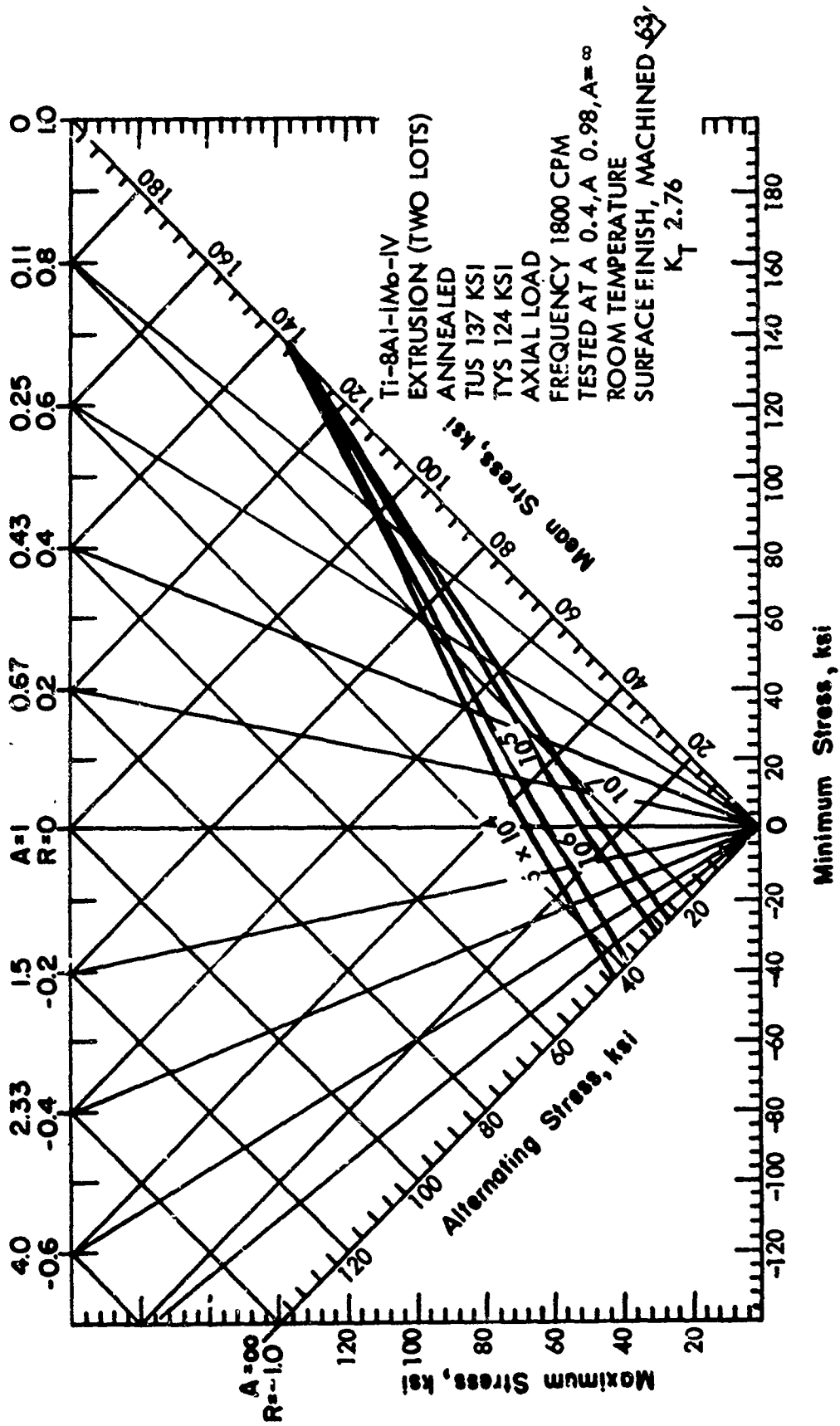

Figure 72. Constant-life Fatigue Diagram for Notched Ti-8Al-1Mo-IV Annealed Extrusions at Room Temperature

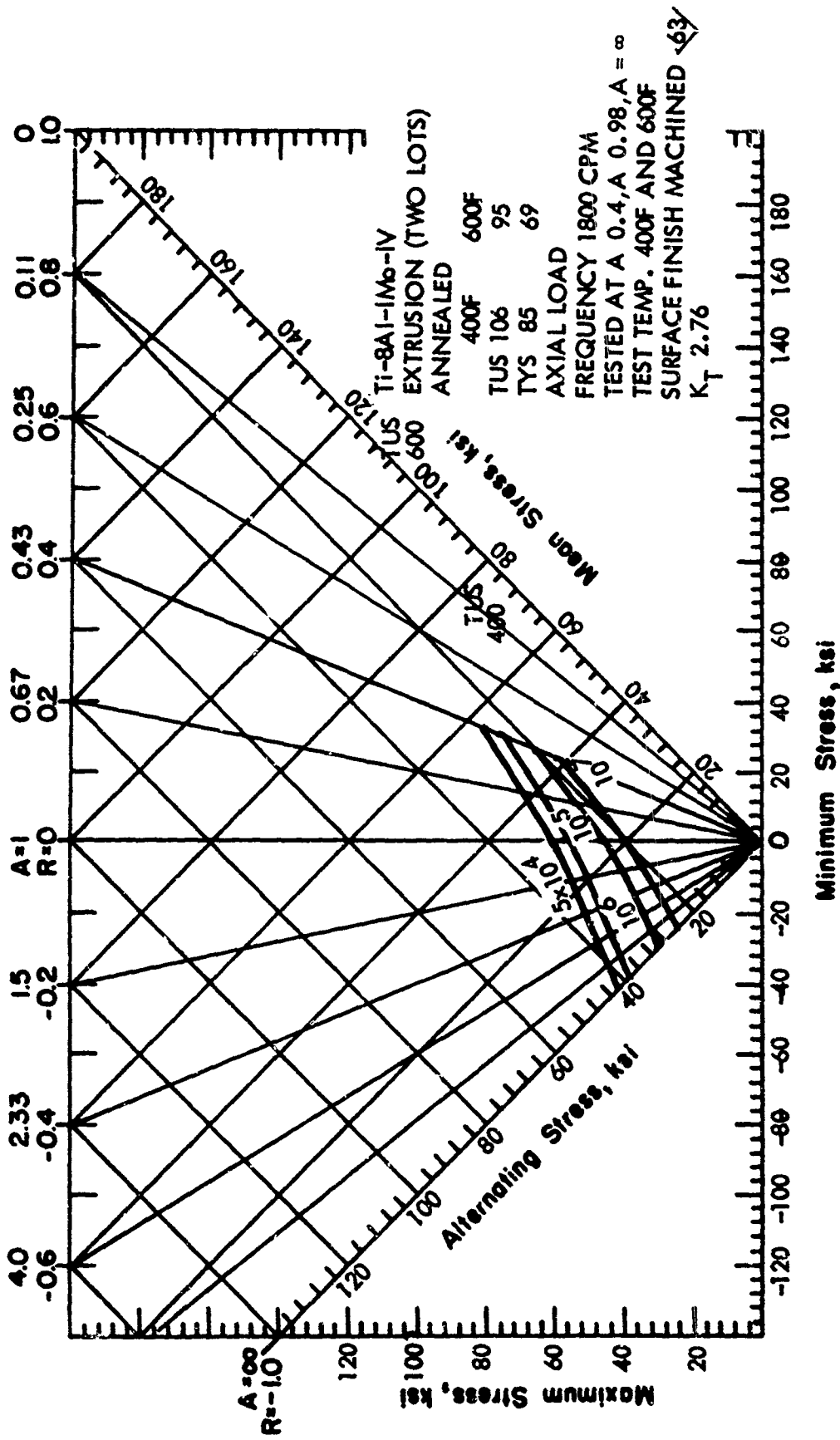

Figure 73. Constant-life Fatigue Diagram for Notched Ti-8Al-1Mo-1V Annealed Extrusions at 400F and 600F

Table XVI Tentative Design Mechanical and Physical Properties
of Ti-6Al-6V-2Sn Titanium Alloy (Extrusions)

| | |
|--|------------------------------------|
| Alloy | Ti-6Al-6V-2Sn |
| Form | Extruded Shapes, Rod and Bar |
| Condition | Annealed |
| Thickness or diameter, in. | |
| Basis | S |
| Mechanical properties: | |
| F_{tu} , ksi | 150 |
| L | 150 |
| LT | |
| F_{ty} , ksi | 135 |
| L | 135 |
| LT | |
| F_{cy} , ksi | (Typical values shown in Table VI) |
| L | |
| LT | |
| F_{su} , ksi | (Typical values shown in Table XI) |
| F_{ru} , ksi: | |
| ($e/D = 1.5$) | (Typical values shown in Table IX) |
| ($e/D = 2.0$) | |
| F_{ry} , ksi: | |
| ($e/D = 1.5$) | (Typical values shown in Table X) |
| ($e/D = 2.0$) | |
| e , per cent: | |
| In 2 in. | 10 |
| In 4 D | 10 |
| E , 10^6 psi | 16.1 |
| E_c , 10^6 psi | |
| G , 10^6 psi | |
| μ | |
| Physical properties: | |
| w , lb/in. ³ | 0.164 |
| C , Btu/(lb)(F) | |
| K , Btu/[(hr)(ft ²)(F)/ft] | |
| α , 10^{-6} in./in./F | |

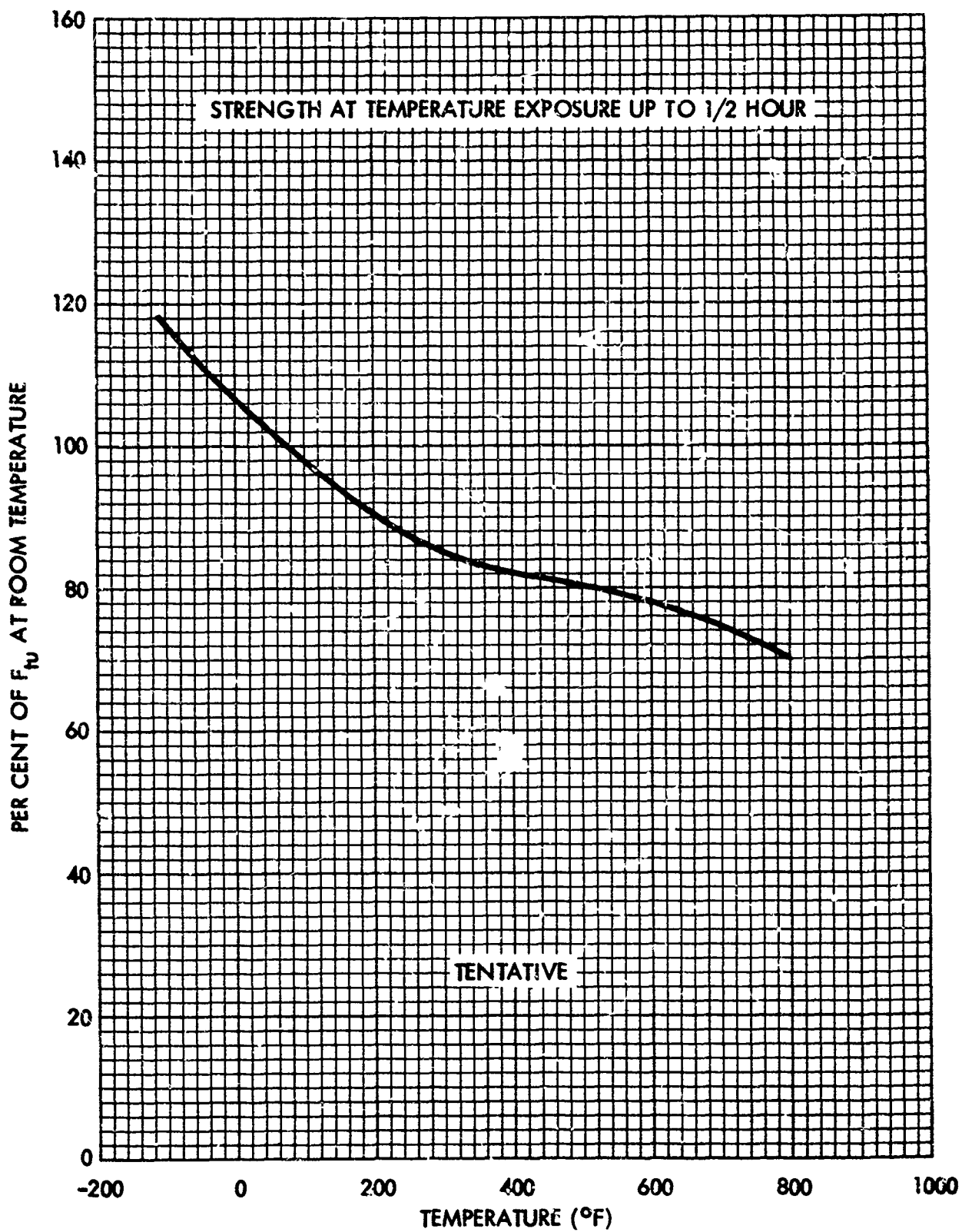

Figure 74. Effect of Temperature on the Ultimate Tensile Strength (F_{tu}) of Annealed Ti-6Al-6V-2Sn Extrusions

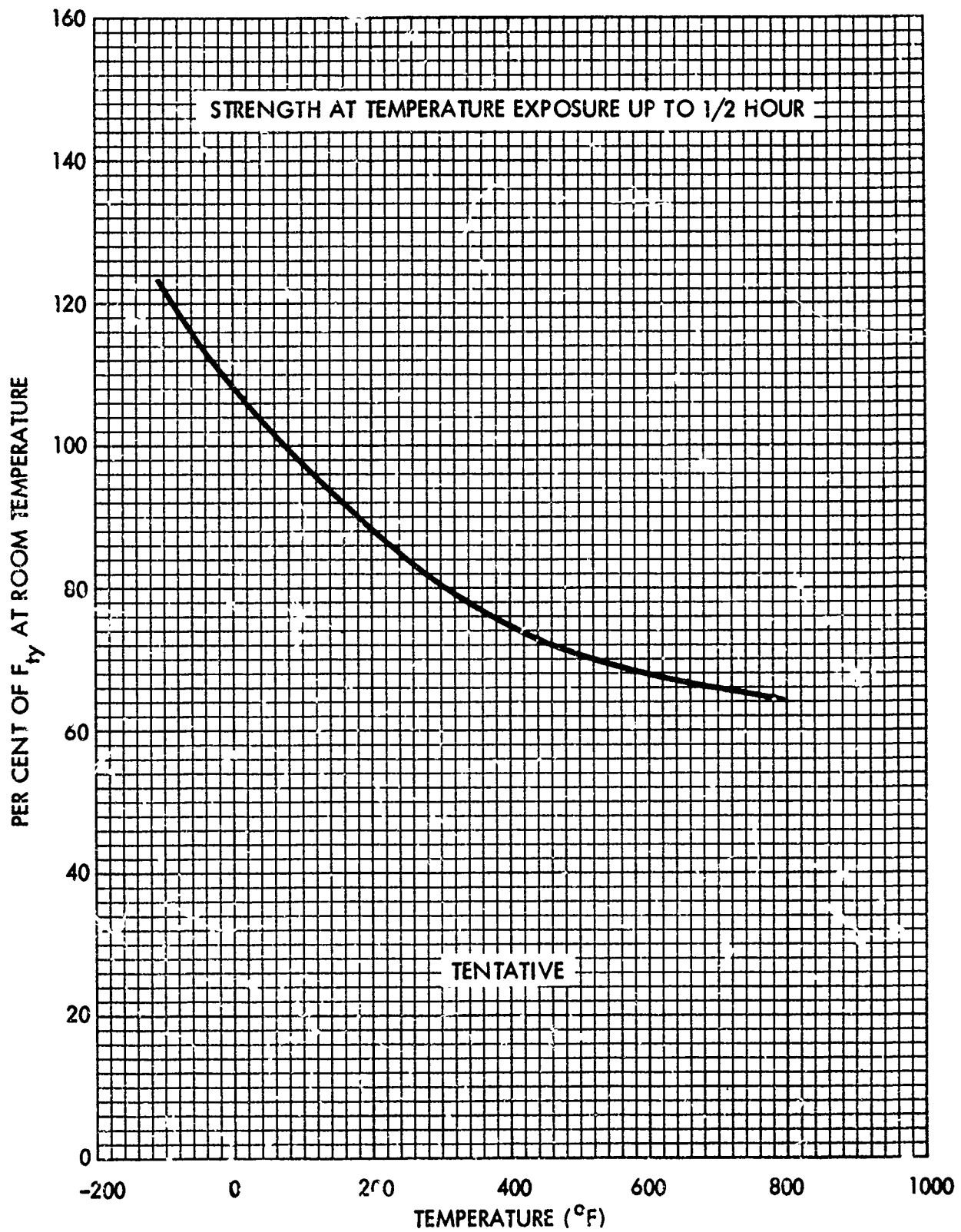

Figure 75. Effect of Temperature on the Tensile Yield Strength (F_{cy}) of Annealed Ti-6Al-6V-2Sn Extrusions

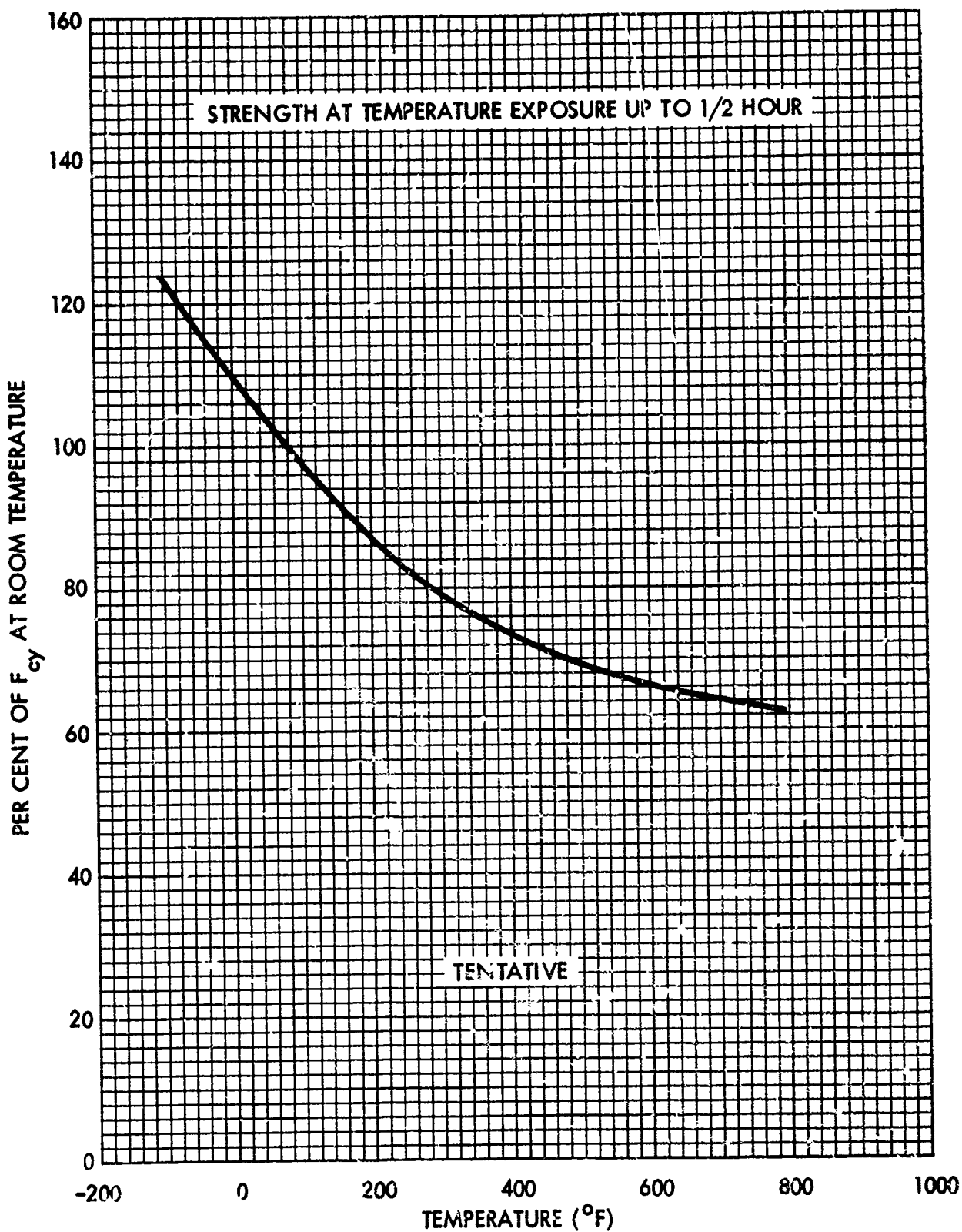

Figure 76. Effect of Temperature on the Compressive Yield Strength (F_{cy}) of Annealed Ti-6Al-6V-2Sn Extrusion

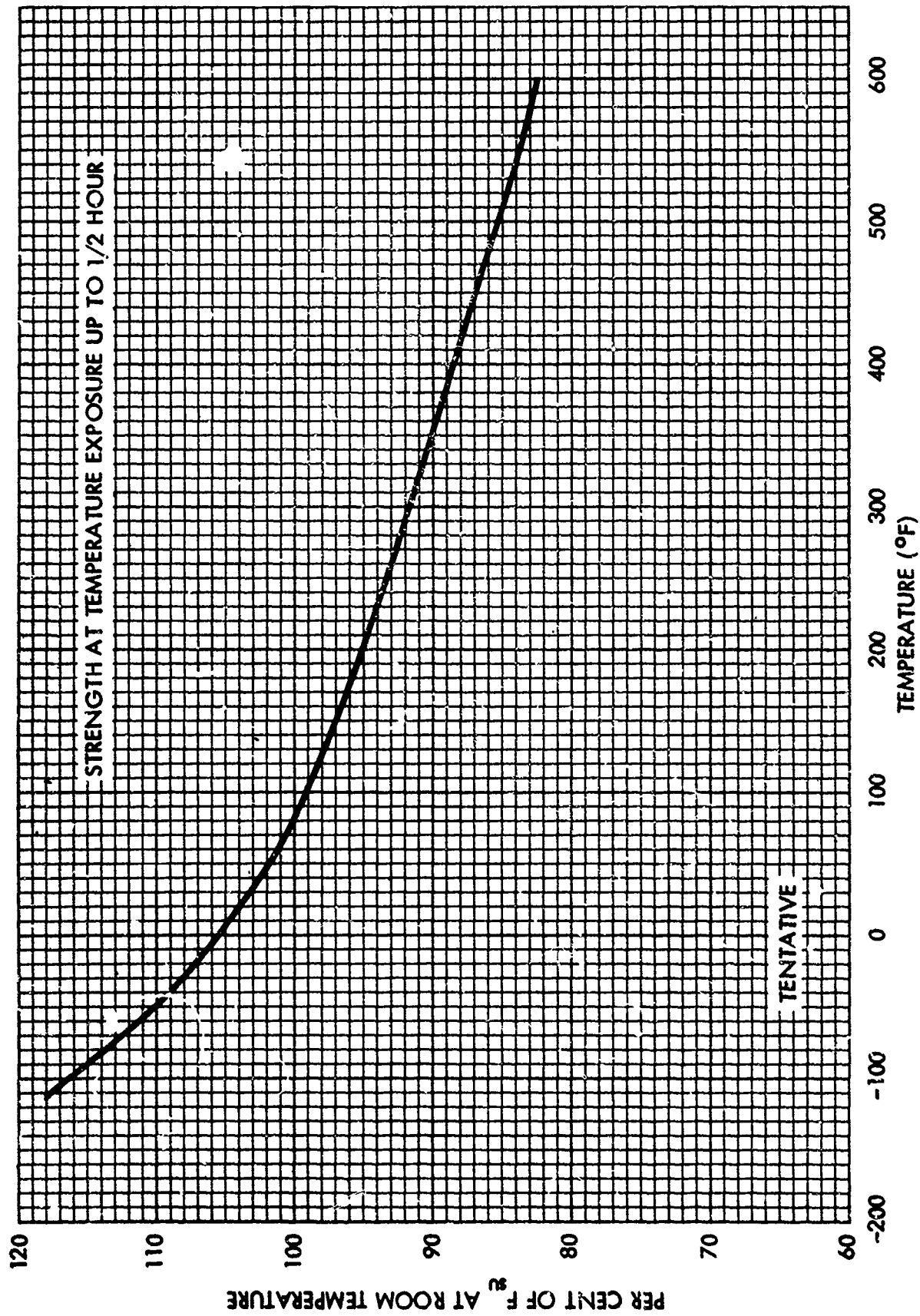

Figure 77. Effect of Temperature on the Ultimate Shear Strength (F_{su}) of Ti-6Al-6V-2Sn Extrusions

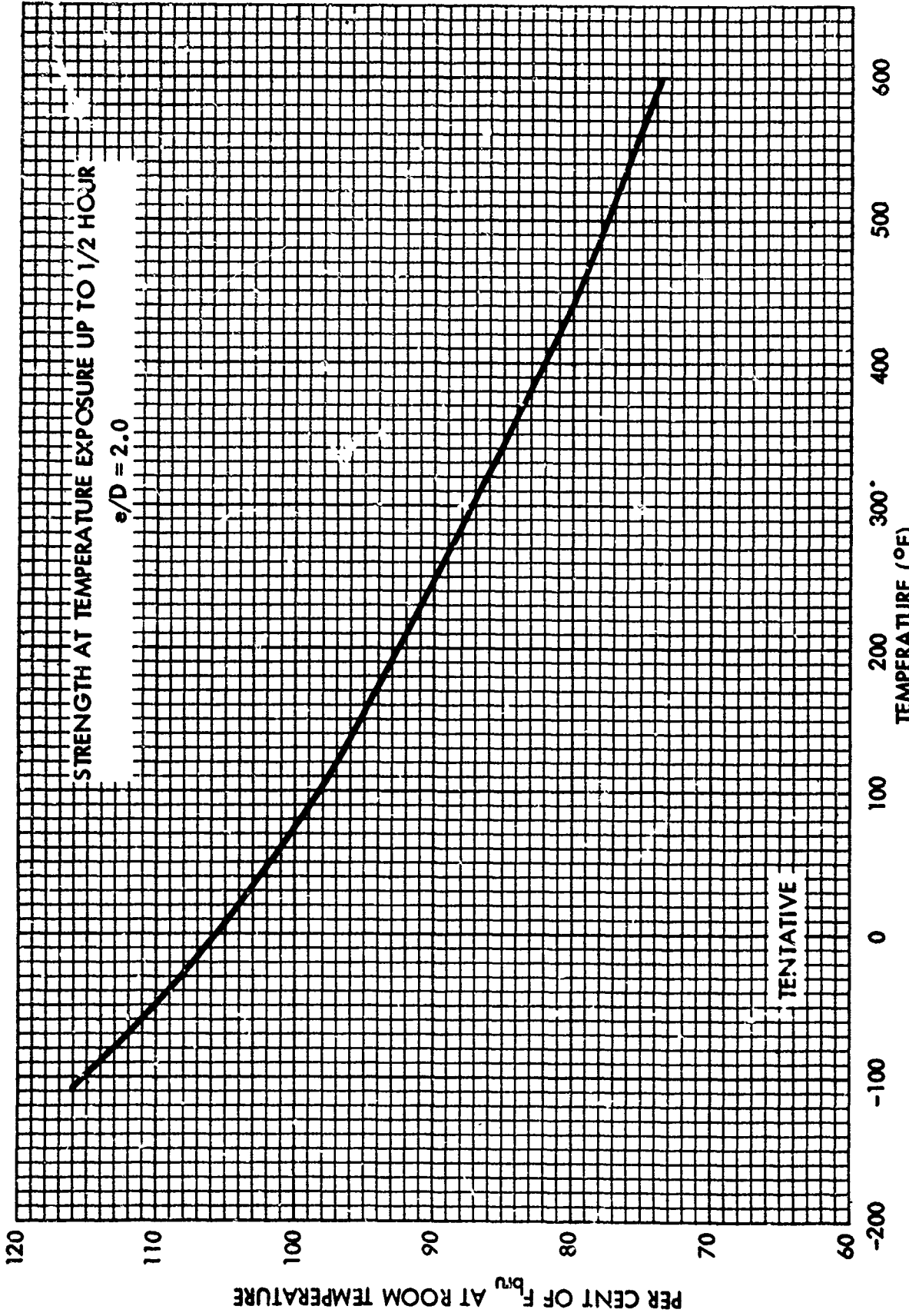

Figure 78. Effect of Temperature on the Ultimate Bearing Strength (F_{bru}) of Ti-6Al-6V-2Sn Extrusions

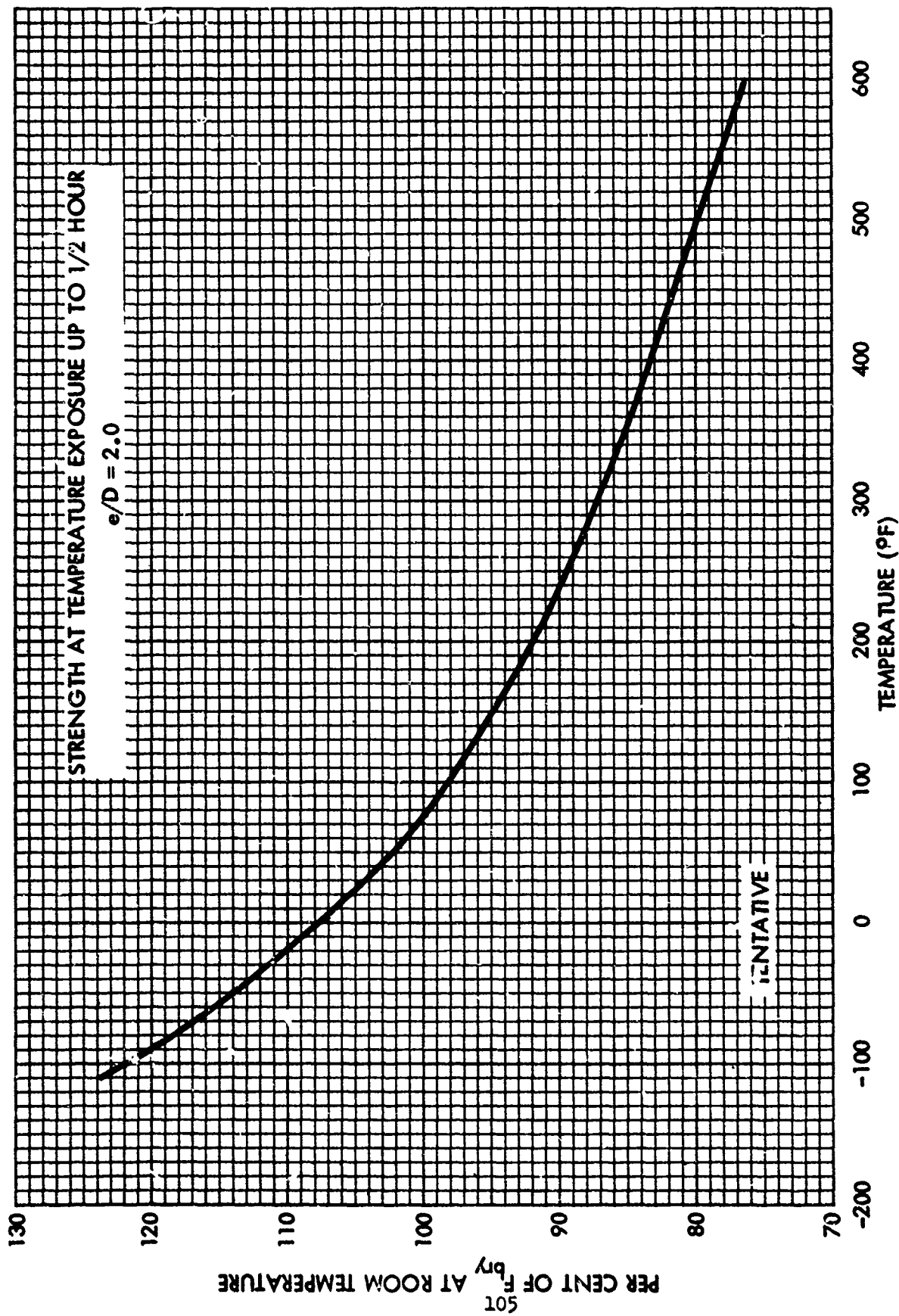

Figure 79. Effect of Temperature on the Bearing Yield Strength (F_{bry}) of Ti-6Al-6V-2Sn Extrusions

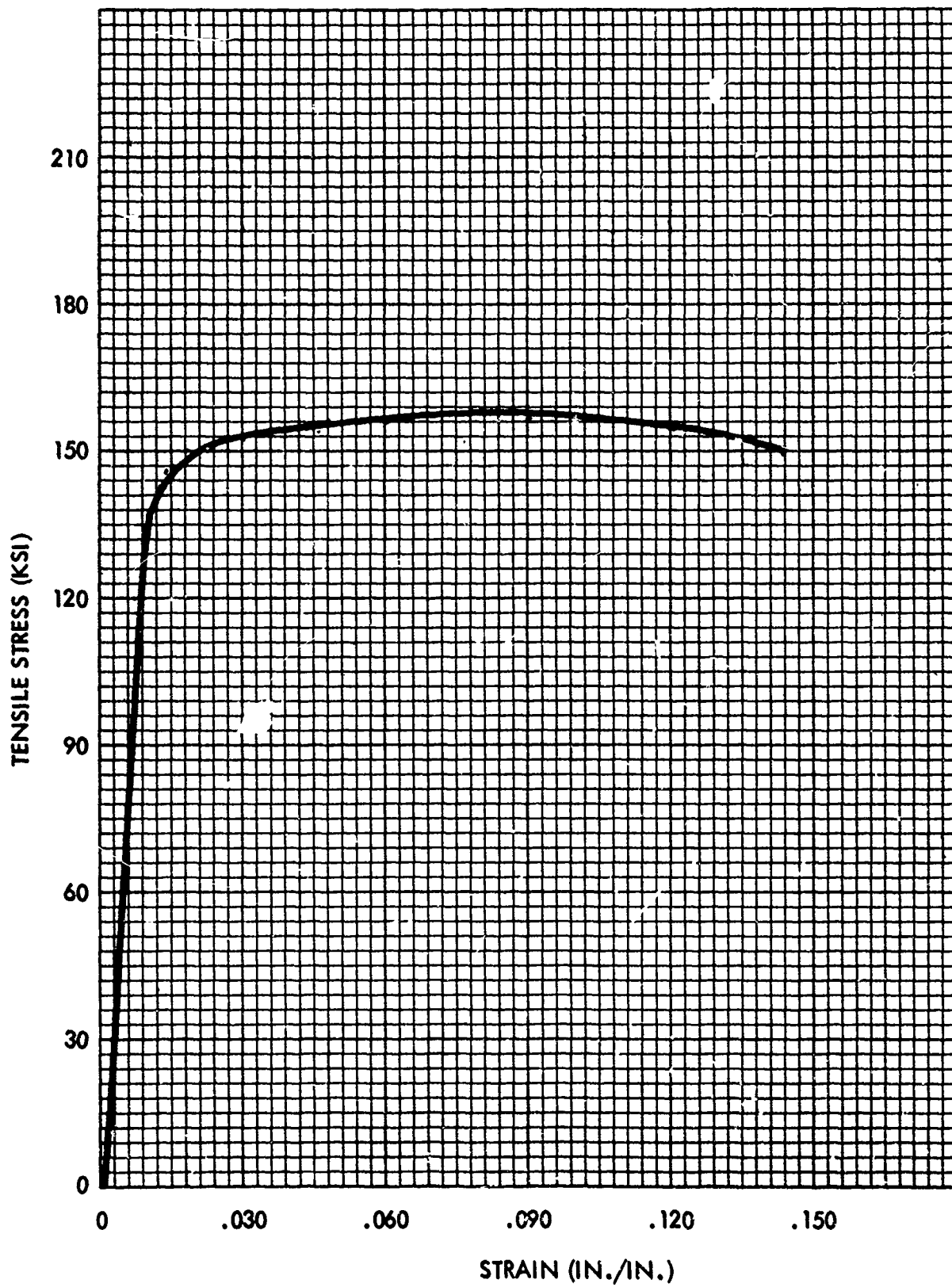

Figure 80. Typical Tensile Stress-Strain Curve
Ti-6Al-6V-2Sn Extrusions at Room Temperature

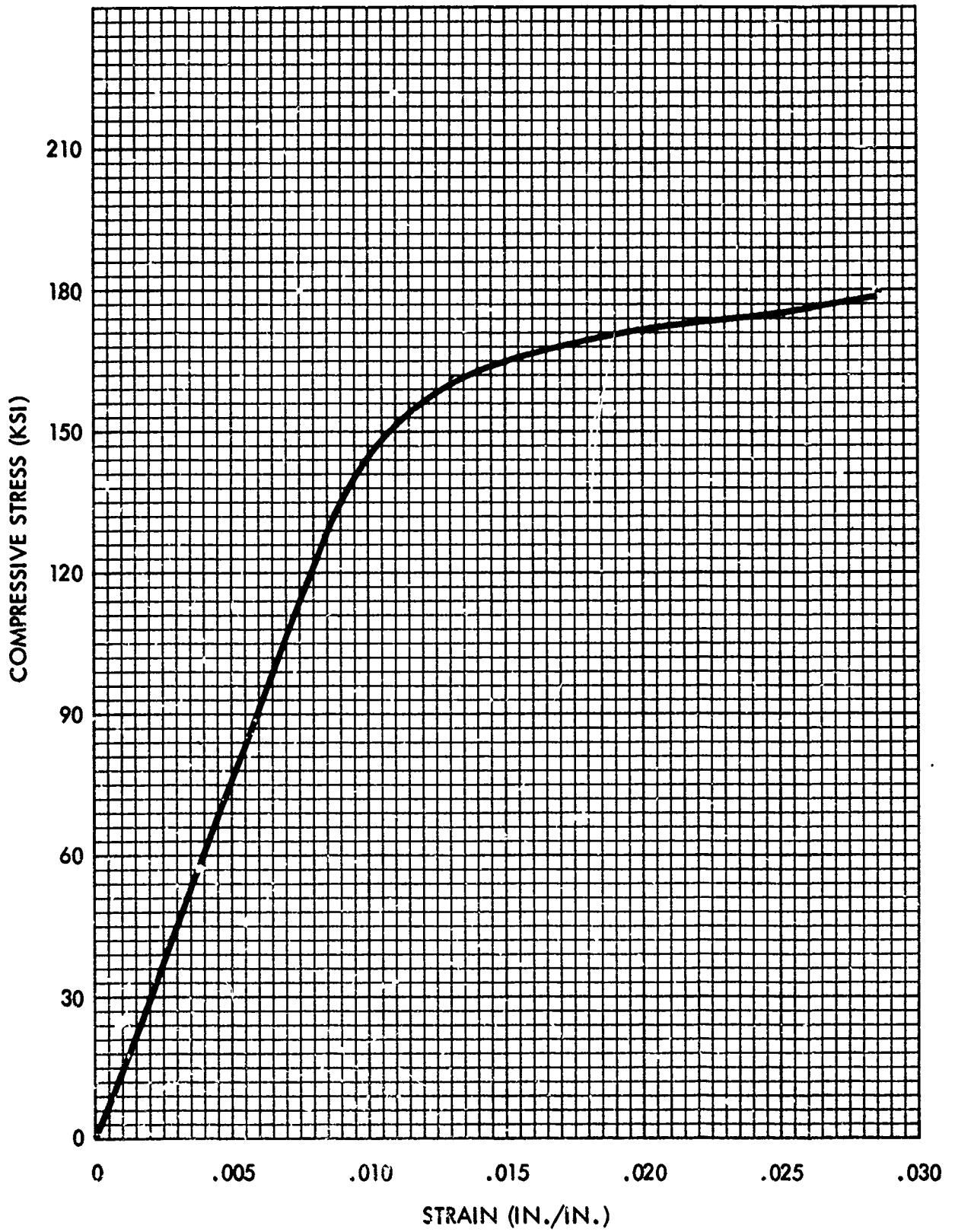

Figure 81. Typical Compressive Stress-Strain Curve
Ti-6Al-6V-2Sn Extrusions at Room Temperature

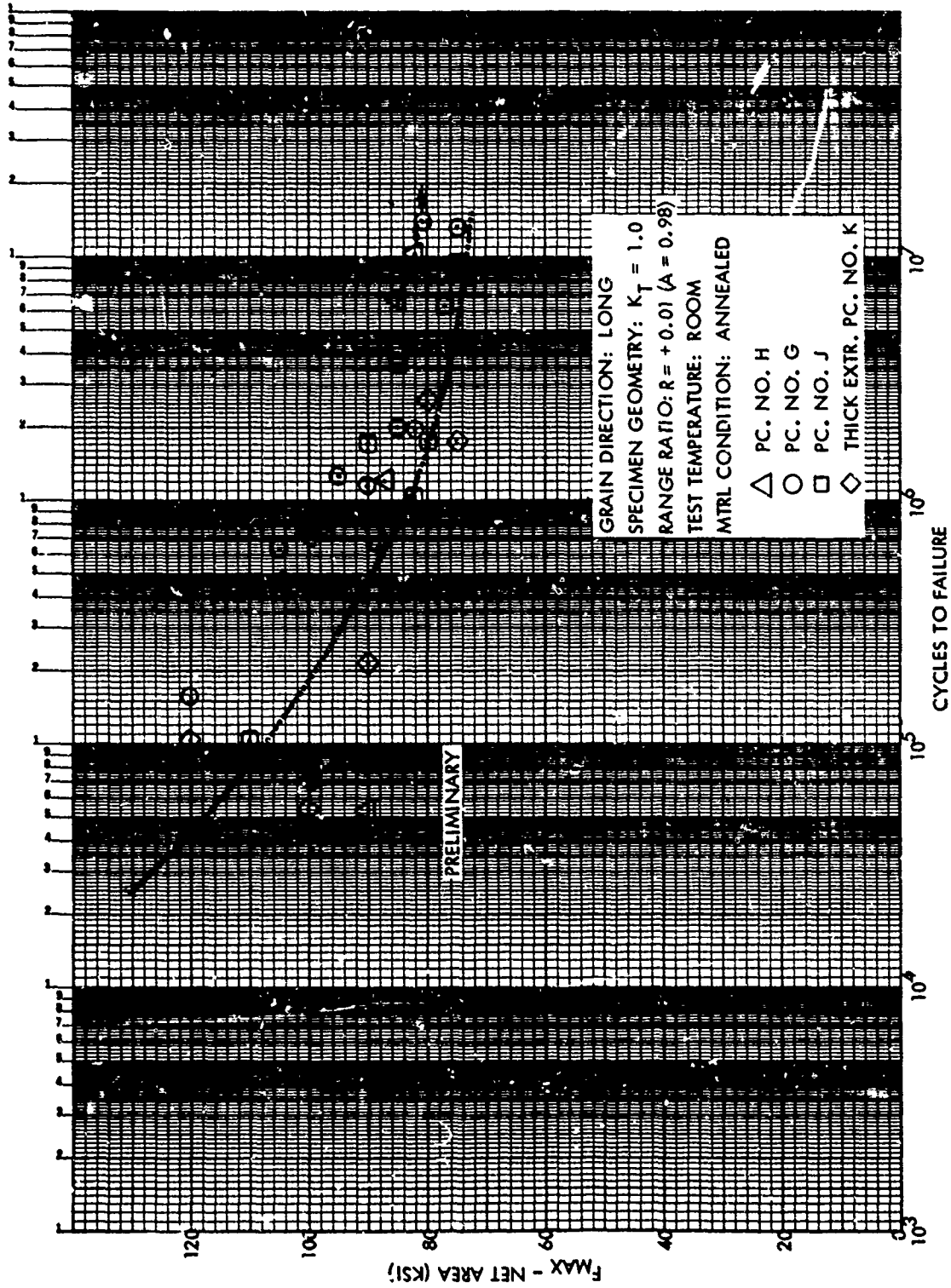

Figure 82. Typical S/N Fatigue Curve for $K_T = 1.0$, Ti-6Al-6V-2Sn Extrusions at Room Temperature

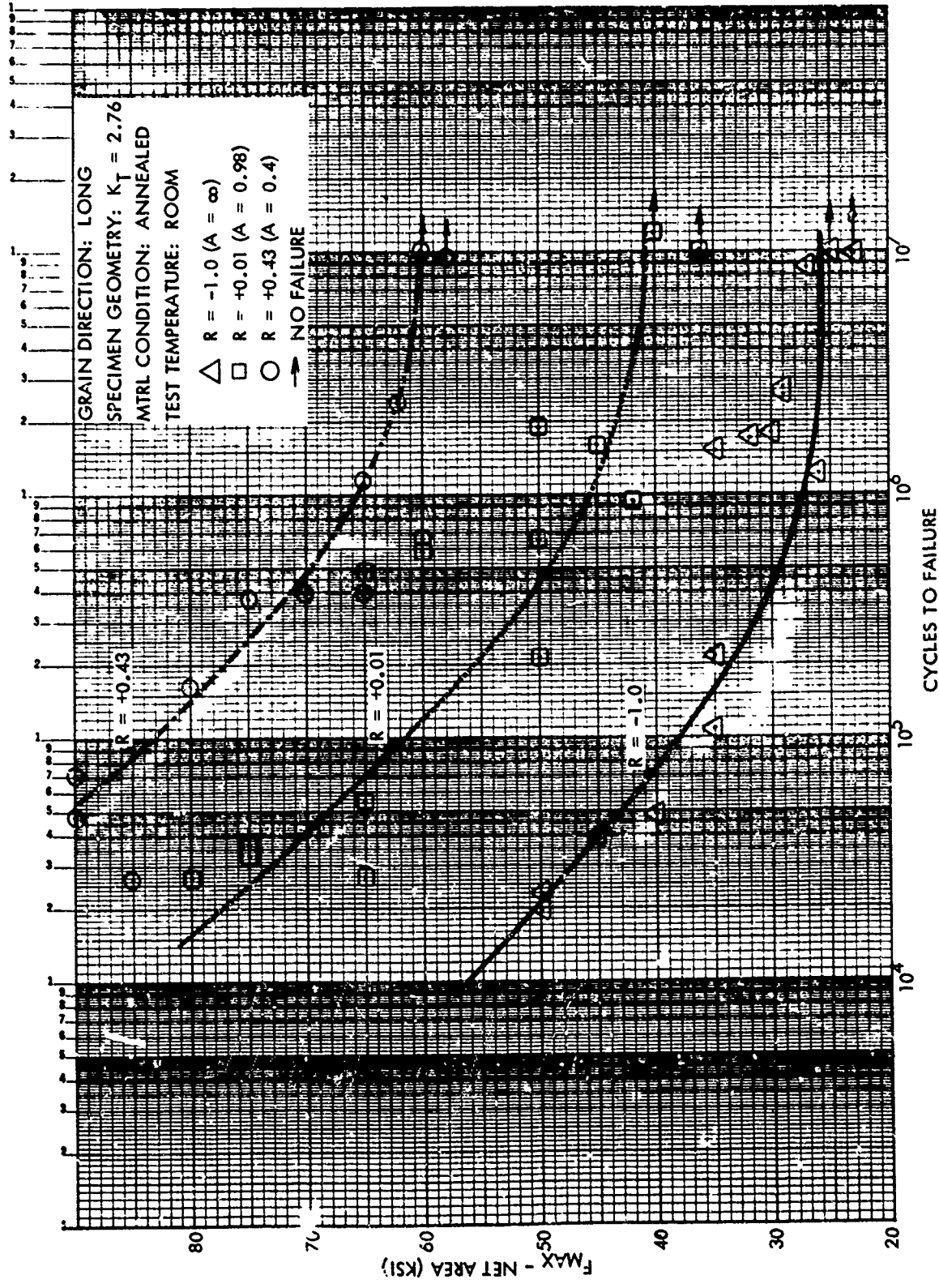

Figure 83. Typical S/N Fatigue Curves for $K_T = 2.76$, ($A =$, $A = 0.98$, $A = 0.4$) Ti-6Al-6V-2Sn Extrusions at Room Temperature

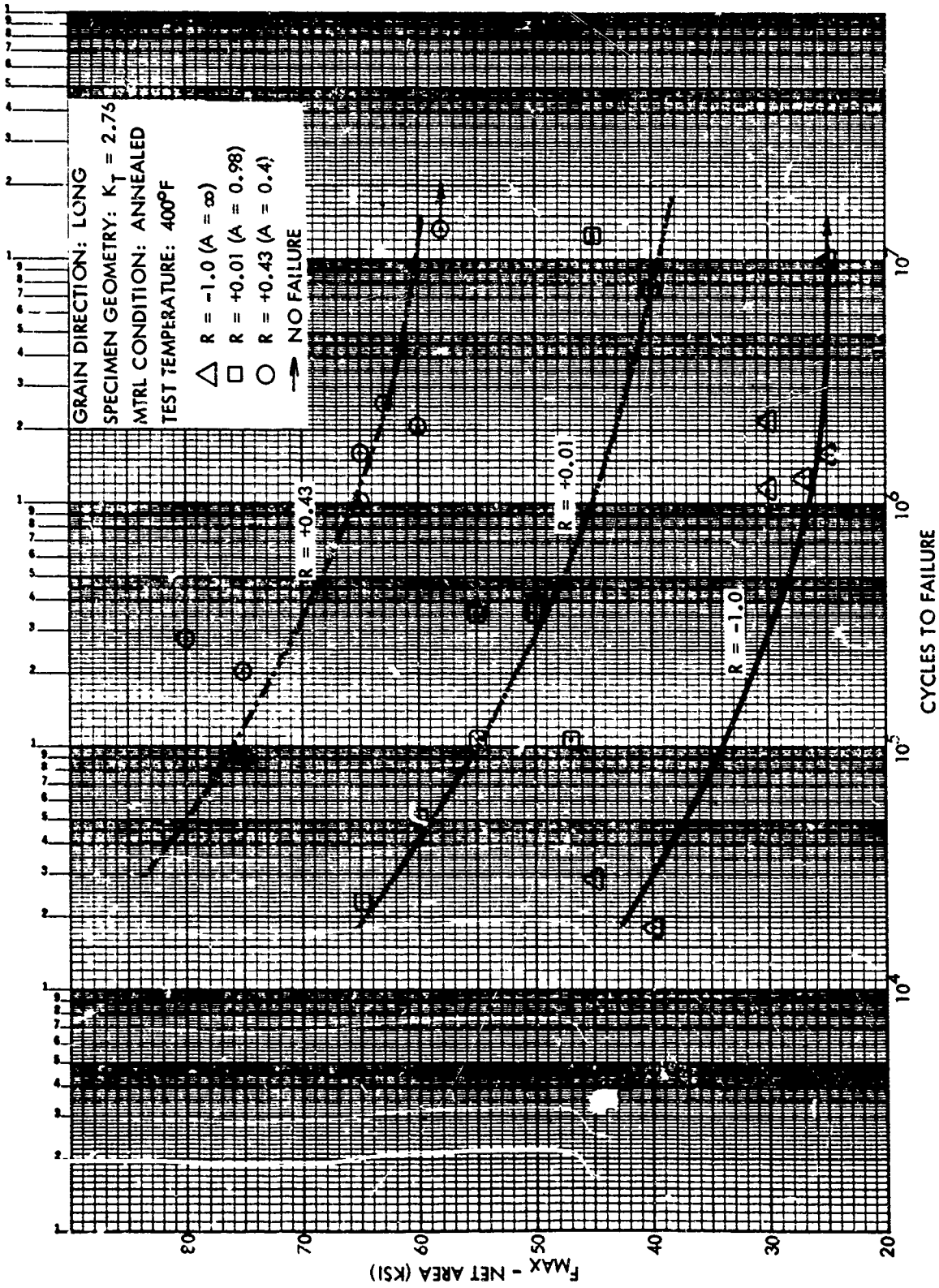

Figure 84. Typical S/N Fatigue Curves for $K_T = 2.75$, ($A = \infty$, $A = 0.98$, $A = 0.4$)
 Ti-6Al-6V-2Sn Extrusions at 400°F

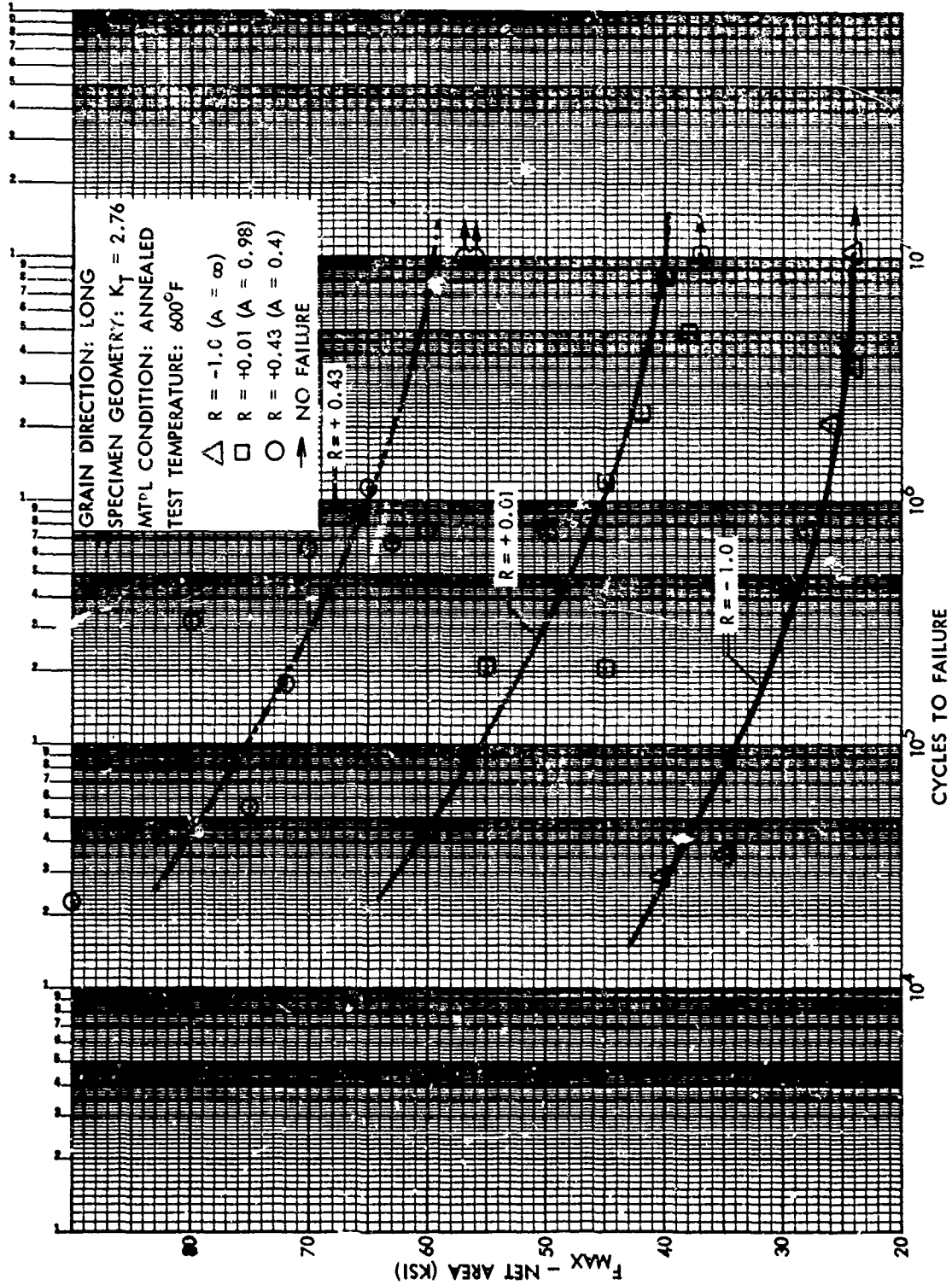

Figure 85. Typical S/N Fatigue Curves for $K_T = 2.76$ ($A = \infty$, $A = 0.98$, $A = 0.4$) T1-6Al-6V-2Sn Extrusions at 600°F

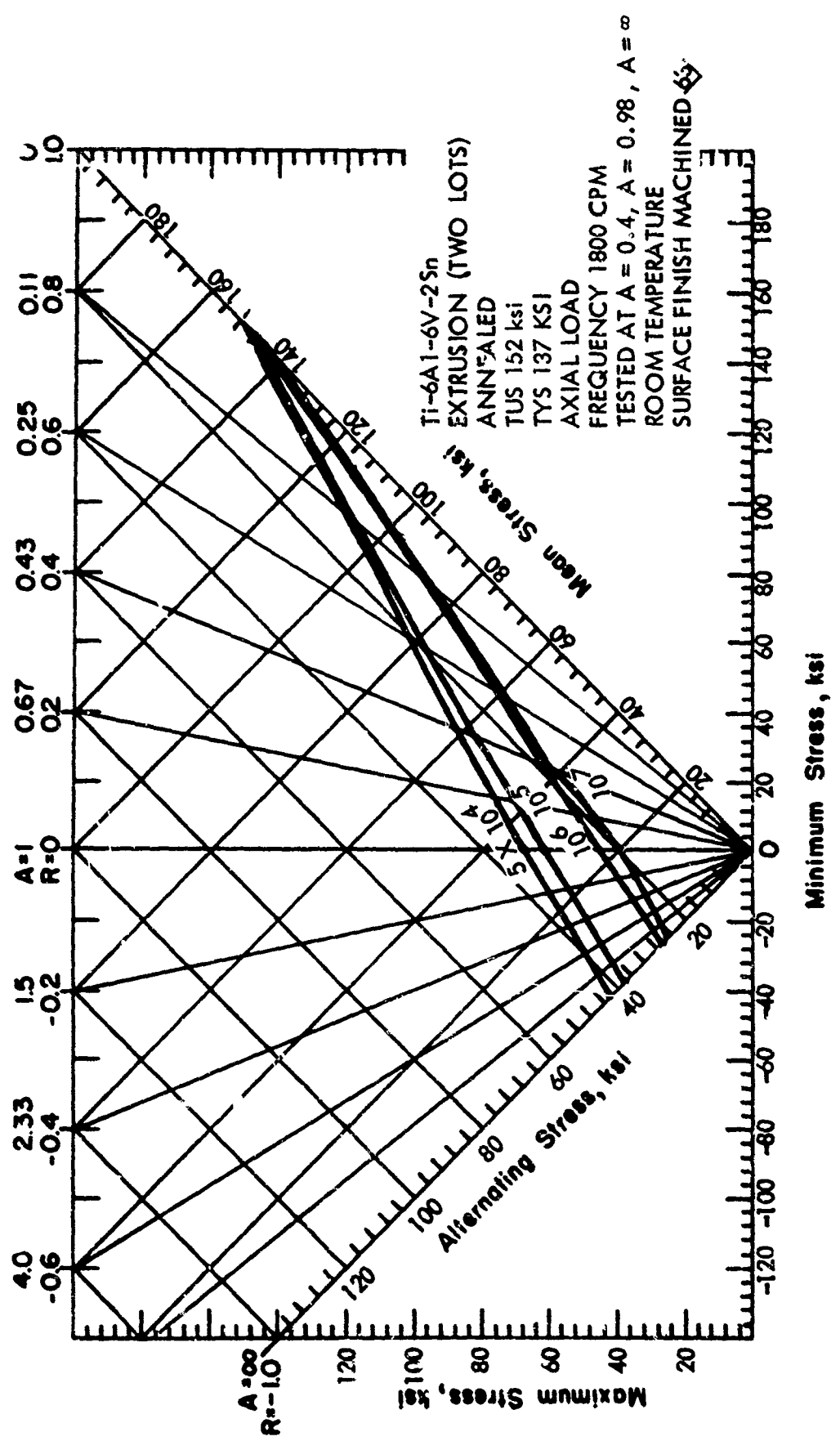

Figure 86. Constant-life Fatigue Diagram for Notched Ti-6Al-6V-2Sn Annealed Extrusions at Room Temperature

Section VI

CONCLUSIONS AND RECOMMENDATIONS

This program has developed data on annealed titanium extrusions to illustrate where the product form possesses advantages over other materials and other forms of titanium when properly applied in aerospace applications. Extruded products are uniform in properties in the section, in its length, and do not possess abnormal directional characteristics. Data indicate that materials from different vendors and from different heats have closely related properties, and that the relationship of properties as affected by environment or application are consistent.

Within the scope of the testing in this program, MIL-HDBK-5 values could not be developed because of the restrictions on the volume of data which could be generated. Sufficient direction and verification was obtained to establish trends and relationships necessary to establish design data.

Titanium extrusions offer advantages in cost and in environmental suitability.

- (1) Because of shape flexibility, savings are usual in material and machining in the type of section where extrusion is adaptable. While machining is required to provide a surface and tolerances suitable for use, machining costs and material costs are generally lower than other heavy product forms.
- (2) In high temperature applications creep characteristics of extrusions appear to be superior to other product forms because of the beta worked metallurgical structure. At applications up to 600F, creep does not appear to be a significant factor, while other product forms may require consideration of creep in order to provide satisfactory life.
- (3) The beta-worked structure of extrusions appears to offer advantages in delayed failure characteristics in corrosive environments. Recent studies of other product forms have shown the desirability of processing or heat treatment in the beta field in order to achieve better toughness and delayed failure characteristics.

In application of titanium extrusions consideration must be given to other effects of its manner of production and its metallurgical structure. Ductility is generally considered to be lower for beta processed material than for material processed in the alpha-beta field. This may have definite effects on forming characteristics and may make use of such products as alpha-beta

processed sheet preferable. Other properties however seem to be of the same order of magnitude as those of other product forms produced with the lower temperature final processing.

Trends shown by this study indicate that temperature effects on extruded products do not conform to those published in MIL-HDEK-5 for other products. Derived property values should be based on extrusion data to insure proper application. In this respect, it should be pointed out that beta-processed material, or beta heat-treated material, in any product form will be having increased usage, and that verification of property relationships for this type material will be required.

To achieve the long range objectives of this program, action should be taken in the following areas:

- (1) Room temperature mechanical property data can at present be established on a specification basis on tensile properties and on compressive yield strength based on vendor guarantees. Sufficient vendor data exists to establish A and B values for Ti-6Al-4V. Data points on Ti-8Al-1Mo-1V and Ti-6Al-6V-2Sn may be more limited when evaluated from Handbook standpoint. Vendor data on compression properties exists in reasonable depth in all alloys.

In establishing values and determining properties, it is suggested that date of production be considered as a variable. Definite changes in property trends have been observed based on refinements, or changes in production techniques. This has been particularly true in Ti-8Al-1Mo-1V, with elimination of furnace cooling, and in Ti-6Al-6V-2Sn where original production was directed toward the special requirements of a single application.

Tentative values for other properties can be established using industry accumulated test data in these areas.

- (2) Property determination programs should be instituted to provide design data for beta processed sheet, plate, and bar. Current trends for application indicate that this processing will be of increasing importance in gages over approximately 0.062 inch.
- (3) Property determination programs should be instituted to provide design data for heat treated and aged (STA) extrusions, and the "Overaged" extrusion where intermediate property levels are established to provide desirable secondary characteristics such as more usable forming temperatures in conjunction with strengths higher than annealed products.
- (4) Studies of rapid heating-rapid load creep characteristics, including repeat cycle effects should be continued to determine specific effects on supersonic aircraft under temperature override conditions, and other vehicles such as spacecraft on re-entry.

Appendix

TABULATION OF TEST RESULTS

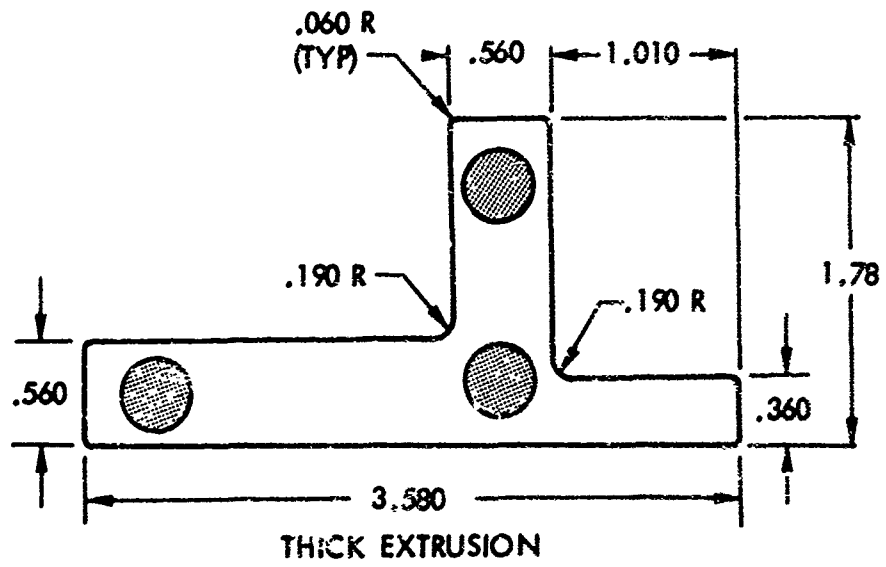
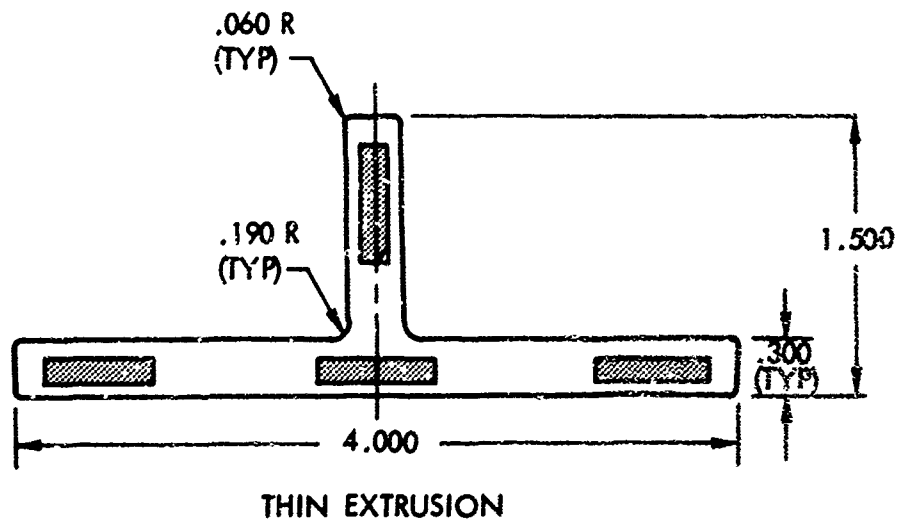
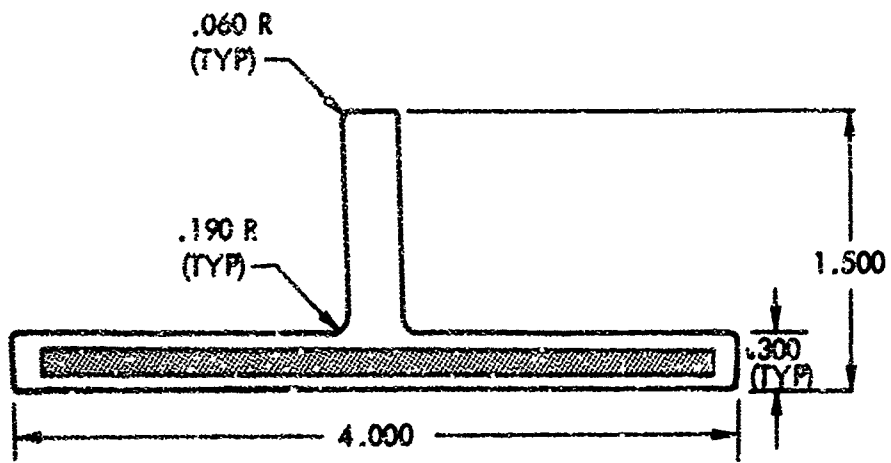
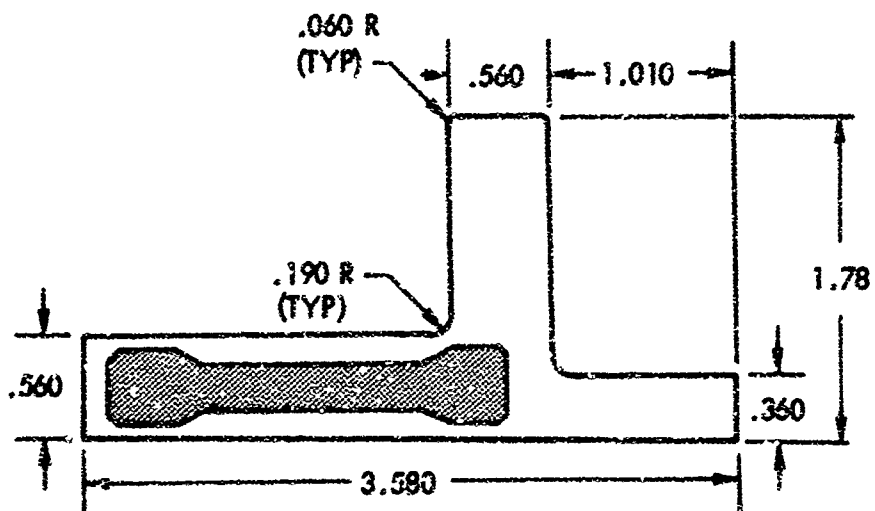

Figure 88. Typical Cross Section Locations Longitudinal Specimens



THIN EXTRUSION



THICK EXTRUSION

Figure 89. Typical Cross Section Locations Transverse Specimens

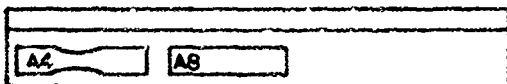
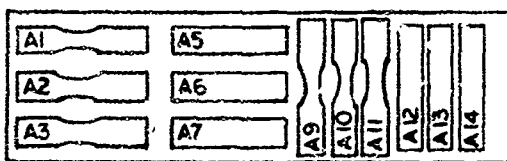
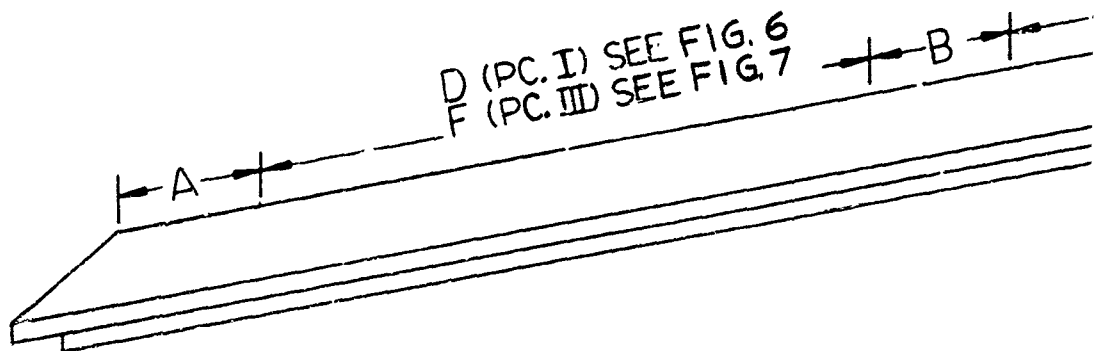

BLOCK A

| SPECIMEN IDENTIFICATION | TYPE TEST | REFERENCE DWG |
|-------------------------|----------------------|---------------|
| A1 THRU A4 | TENSILE, LONGIT. | FIG. 11 |
| A5 THRU A8 | COMPRESSION, LONGIT. | FIG. 12 |
| A9, A10, A11 | TENSILE, TRANSVERSE | FIG. 11 |
| A12, A13, A14 | COMPRESSION, TRANS. | FIG. 12 |

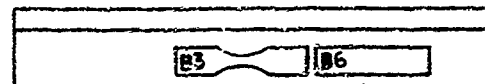
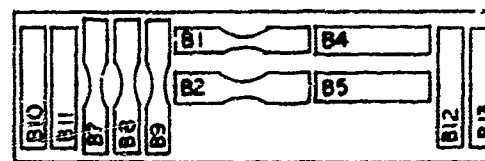

TOP

SIDE

BLOCK B

| SPECIMEN IDENTIFICATION | TYPE TEST | REF DWG |
|-------------------------|----------------------|---------|
| B1, B2, B3 | TENSILE, LONGIT. | |
| B4, B5, B6 | COMPRESSION, LONGIT. | |
| B7, B8, B9 | TENSILE, TRANSVERSE | |
| B10 THRU B15 | COMPRESSION, TRANS. | |



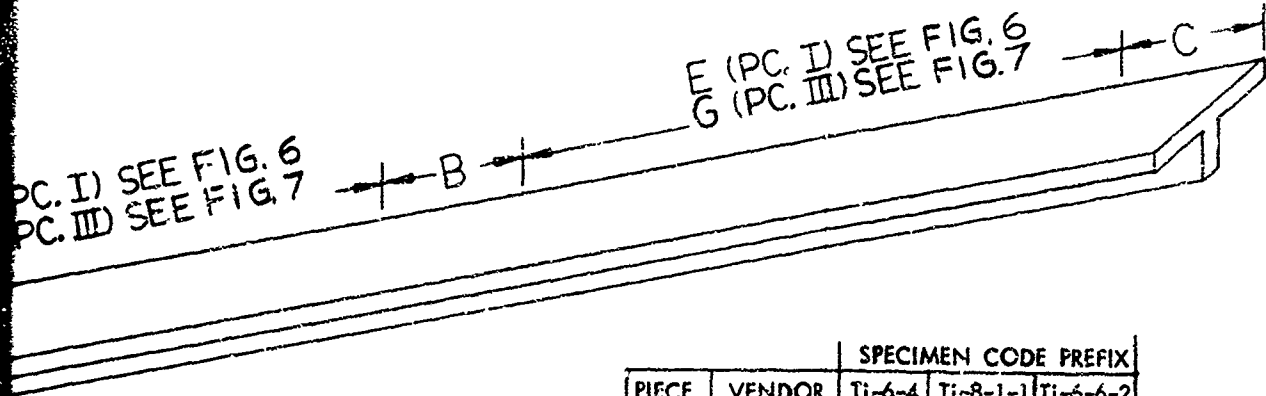

| PIECE | VENDOR | SPECIMEN CODE PREFIX | | |
|-------|--------|----------------------|----------|----------|
| | | Ti-6-4 | Ti-8-1-1 | Ti-6-6-2 |
| I | HARVEY | A | F | L |
| III | HARPER | C | H | N |

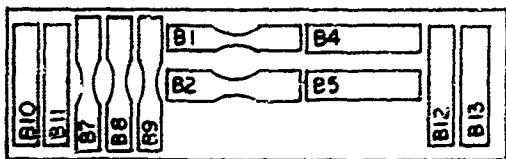

TOP

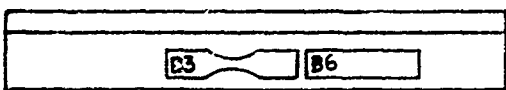
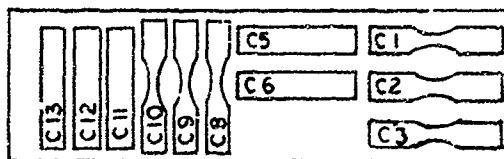

SIDE

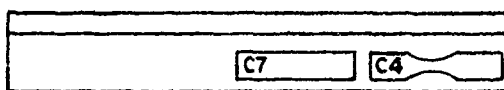

BLOCK B

BLOCK C

| SPECIMEN IDENTIFICATION | TYPE TEST | REFERENCE DWG |
|-------------------------|----------------------|---------------|
| B1, B2, B3 | TENSILE, LONGIT. | FIG 11 |
| B4, B5, B6 | COMPRESSION, LONGIT. | FIG 12 |
| B7, B8, B9 | TENSILE, TRANSVERSE | FIG 11 |
| B10 THRU B13 | COMPRESSION, TRANS. | FIG 12 |

| SPECIMEN IDENTIFICATION | TYPE TEST | REFERENCE DWG |
|-------------------------|----------------------|---------------|
| C1 THRU C4 | TENSILE, LONGIT. | FIG. 11 |
| C5, C6, C7 | COMPRESSION, LONGIT. | FIG. 12 |
| C8, C9, C10 | TENSILE, TRANS. | FIG. 11 |
| C11, C12, C13 | COMPRESSION, TRANS. | FIG. 12 |

Figure 90. Specimen Locations, Pieces I and III (Part of)

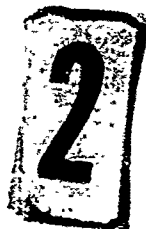

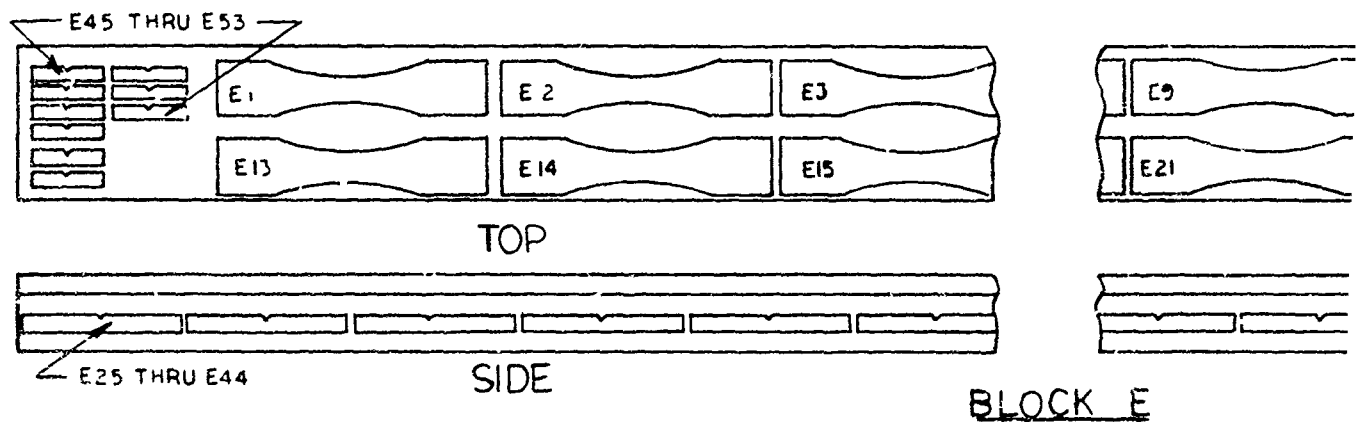
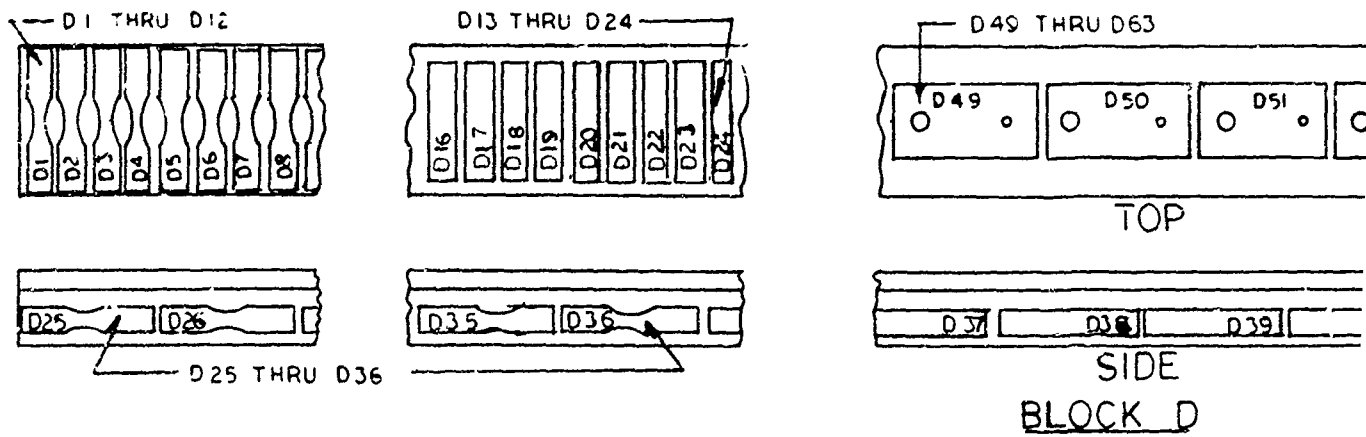

BLOCK D

| SPECIMEN IDENTIFICATION | TEST TYPE | REFERENCE DWG |
|-------------------------|----------------------|---------------|
| D1 THRU D12 | TENSILE, TRANSVERSE | FIG. 11 |
| D13 THRU D24 | COMPRESSION, TRANS. | FIG. 12 |
| D25 THRU D36 | TENSILE, LONGIT. | FIG. 11 |
| D37 THRU D48 | COMPRESSION, LONGIT. | FIG. 12 |
| D49 THRU D63 | BEARING, LONGIT. | FIG. 14 |
| D64 THRU D69 | BEARING, TRANS. | FIG. 14 |
| D70 THRU D84 | SHEAR, LONGIT. | FIG. 13 |
| D85, D86, D87 | SHEAR, TRANS. | FIG. 13 |

| SP. ID# |
|---------|
| E1 |
| E2 |
| E4 |



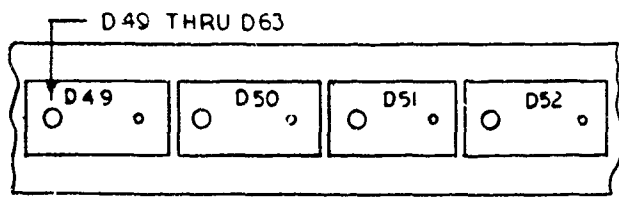

TOP

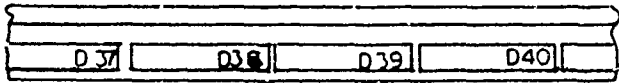

SIDE
BLOCK D

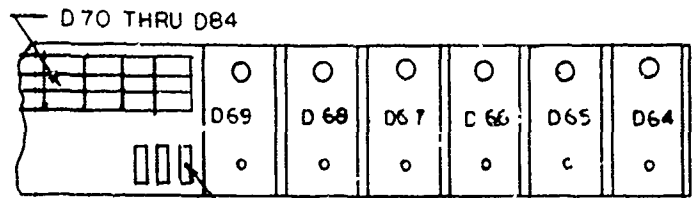

D85 THRU D87

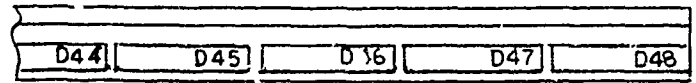

D 37 THRU D48

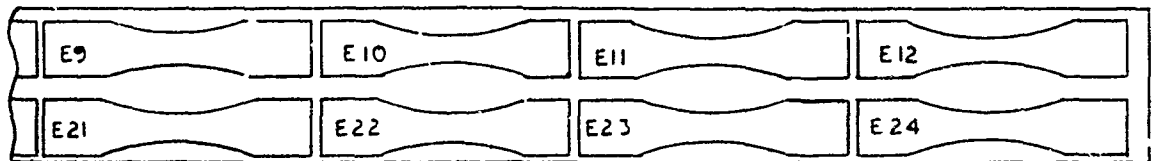
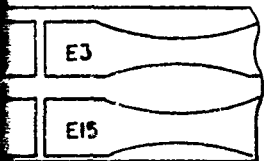

TOP

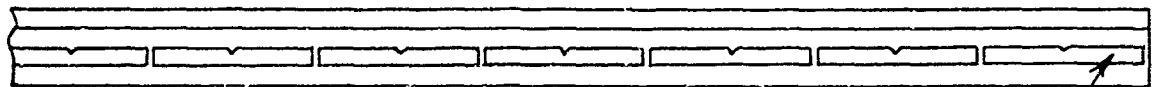
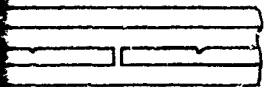

SIDE

E25 THRU E44

BLOCK E

BLOCK E

| SPEC IDEN | REFERENCE DWG |
|-----------|---------------|
| E1 | FIG. 11 |
| E25 | FIG. 12 |
| E45 | FIG. 11 |
| | FIG. 12 |
| | FIG. 14 |
| | FIG. 14 |
| | FIG. 18 |
| | FIG. 18 |

| SPECIMEN IDENTIFICATION | TEST TYPE | REFERENCE DWG |
|-------------------------|----------------------------------|---------------|
| E1 THRU E24 | CREEP, STRESS RUPTURE | FIG. 15 |
| E25 THRU E44 | FRACTURE TOUGHNESS | FIG. 19 |
| E45 THRU E53 | DELAYED FAILURE CHARPY IMPACT | FIG. 17 |

| PIECE | VENDOR | SPECIMEN CODE PREFIX | | |
|-------|--------|----------------------|----------|----------|
| | | Ti-6-4 | Ti-8-1-1 | Ti-6-6-2 |
| I | HARVEY | A | F | L |

Figure 91. Specimen Locations, Piece I (Cont)

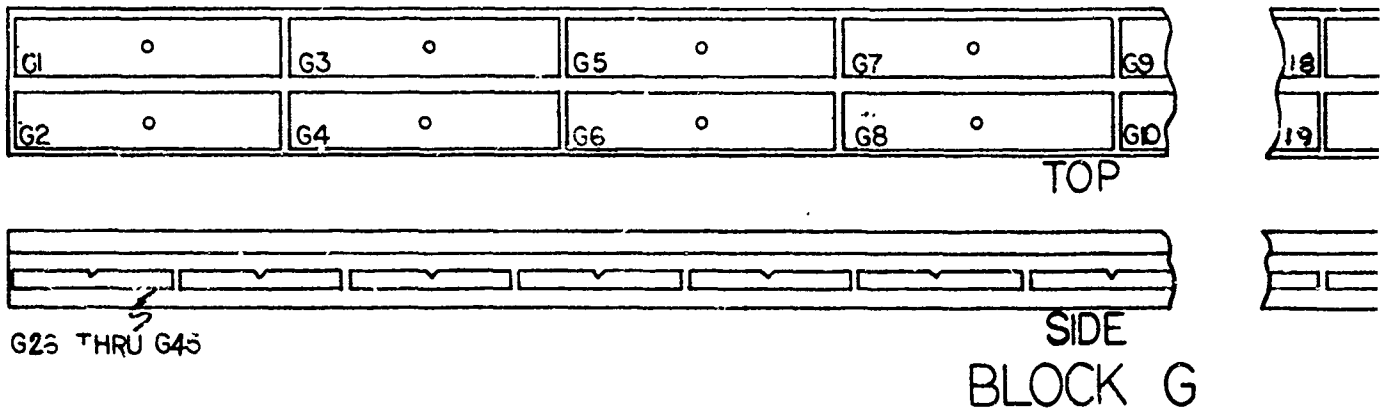
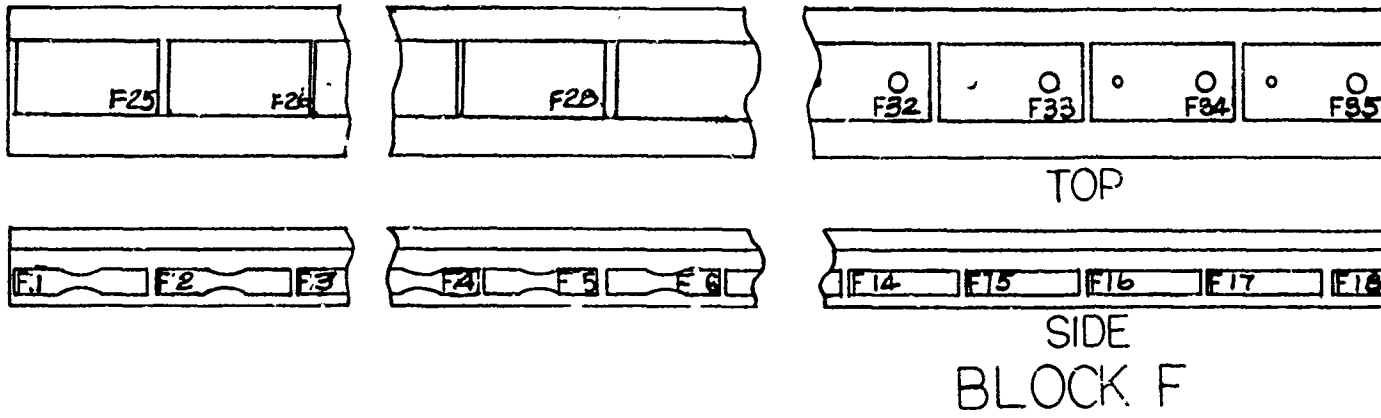

BLOCK F

| SPECIMEN IDENTIFICATION | TEST TYPE | REFERENCE DWG |
|-------------------------|------------------------|---------------|
| F1 THRU F12 | TENSILE, LONGITUD. | FIG. 11 |
| F13 THRU F24 | COMPRESSION, LONGITUD. | FIG. 12 |
| F25 THRU F36 | BEARING, LONGITUD. | FIG. 14 |
| F37 F38 F39 | BEARING, TRANS. | FIG. 14 |
| F40 THRU F48 | CHARPY, TRANS. | FIG. 17 |
| F49 THRU F57 | CHARPY, LONGIT. | FIG. 17 |
| F58 THRU F69 | SHEAR, LONGITUD. | FIG. 13 |
| F70 THRU F75 | SHEAR, TRANS. | FIG. 13 |

| SPECIMEN IDENTIFICATION |
|-------------------------|
| G1 THRU |
| G16 THRU |
| G26 THRU |



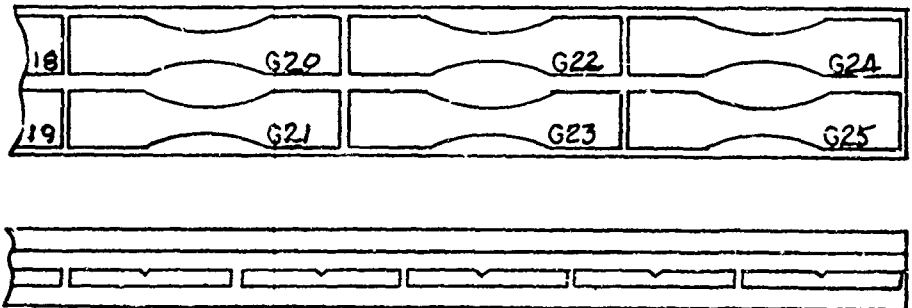
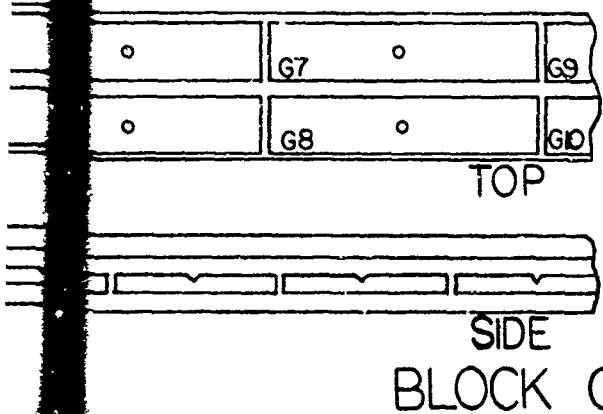
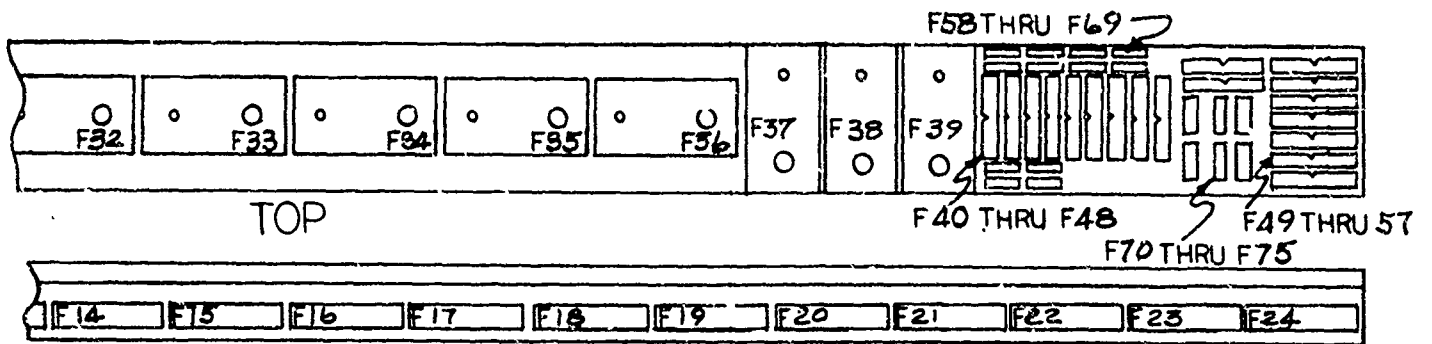

BLOCK G

| SPECIMEN IDENTIFICATION | TEST TYPE | REFERENCE DWG |
|-------------------------|--|---------------|
| G1 THRU G15 | NOTCHED FATIGUE ($K_t=2.7$) | FIG. 21 |
| G16 THRU G25 | SMOOTH FATIGUE ($K_t=1.0$) | FIG. 20 |
| G26 THRU G45 | FRACTURE TOUGHNESS/ DELAYED FAILURE | FIG. 19 |

| EN | REFERENCE DWG |
|-----|---------------|
| U G | FIG. 11 |
| HRU | FIG. 12 |
| RU | FIG. 14 |
| | FIG. 14 |
| | FIG. 17 |
| | FIG. 17 |
| | FIG. 13 |
| | FIG. 13 |

| PIECE | VENDOR | SPECIMEN CODE PREFIX | | |
|-------|--------|----------------------|----------|----------|
| | | Ti-6-4 | Ti-8-1-1 | Ti-6-6-2 |
| III | HARPER | C | H | N |

Figure 92. Specimen Locations, Piece III (Cont)

2

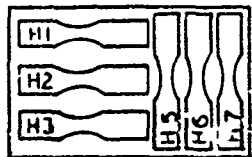
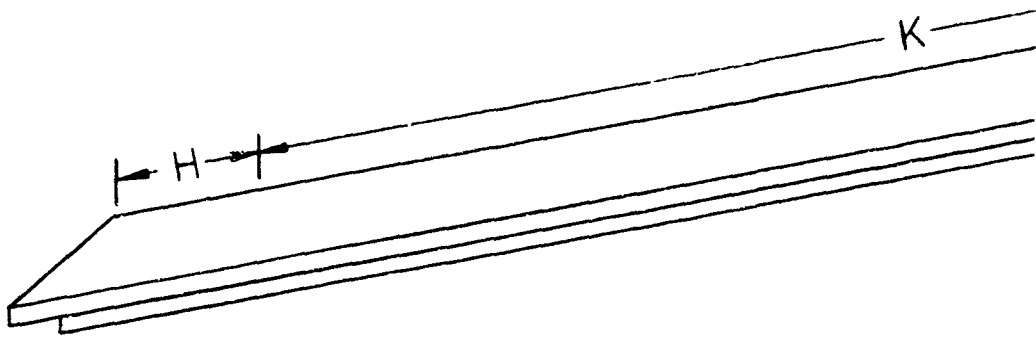

TOP



TOP

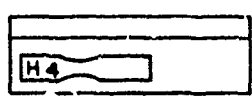
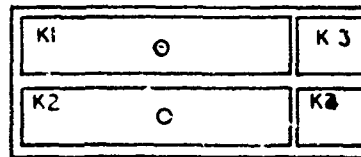

SIDE



SIDE

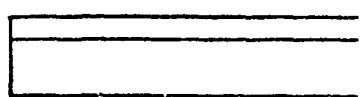

BLOCK H

| SPECIMEN IDENTIFICATION | TYPE TEST | REFERENCE DWG |
|--------------------------|--|--------------------|
| H1 THRU H4 H5, H6, H7 | TENSILE, LONGIT TENSILE, TRANSVERSE | FIG. 11 FIG. 11 |

BLOCK J

| SPECIMEN IDENTIFICATION | TYPE TEST |
|-------------------------|---------------------|
| J1, J2, J3 | TENSILE, TRANSVERSE |

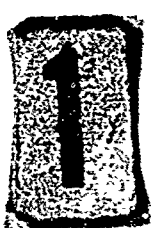

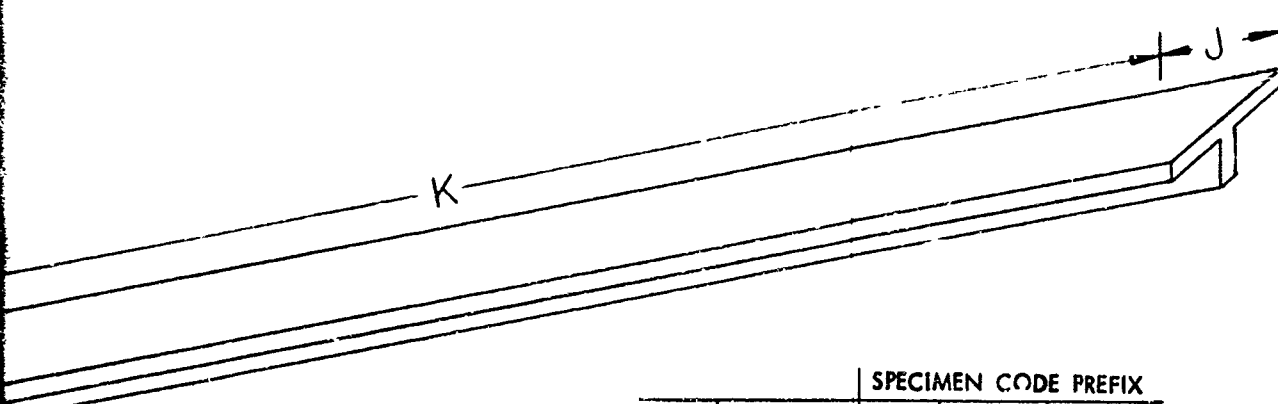

| PIECE | VENDOR | SPECIMEN CODE PREFIX | | |
|-------|--------|----------------------|----------|----------|
| | | Ti-6-4 | Ti-8-1-1 | Ti-6-6-2 |
| II | HARVEY | B | G | M |
| IV | HARPER | D | J | P |

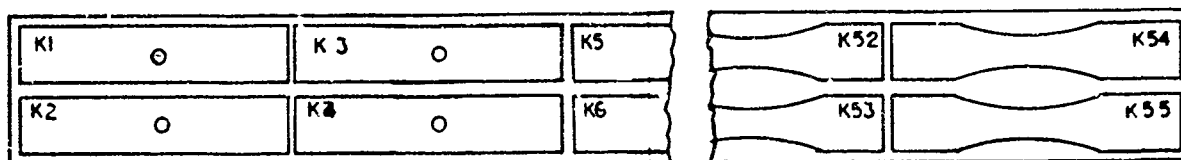

TOP

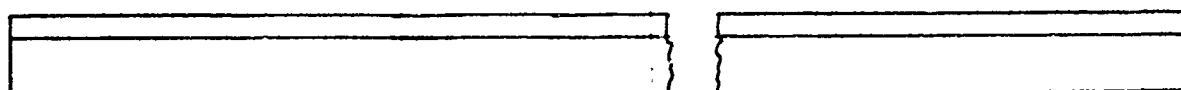

SIDE

BLOCK J

| SPECIMEN IDENTIFICATION | TYPE TEST | REFERENCE DWG |
|-------------------------|---------------------|---------------|
| J1, J2, J3 | TENSILE, TRANSVERSE | FIG. 11 |

BLOCK K

| SPECIMEN IDENTIFICATION | TYPE TEST | REFERENCE DWG |
|-------------------------|------------------------------------|---------------|
| K1 THRU K45 | NOTCHED FATIGUE ($K_T = 2.7$) | FIG. 21 |
| K46 THRU K55 | SMOOTH FATIGUE ($K_T = 1.0$) | FIG. 20 |

Figure 93. Specimen Locations, Pieces II and IV

2

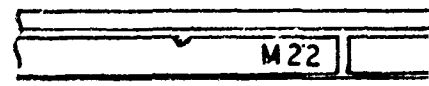
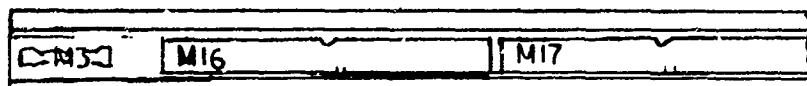
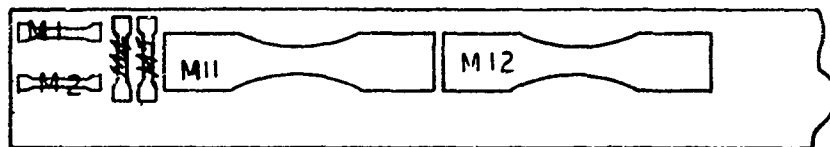
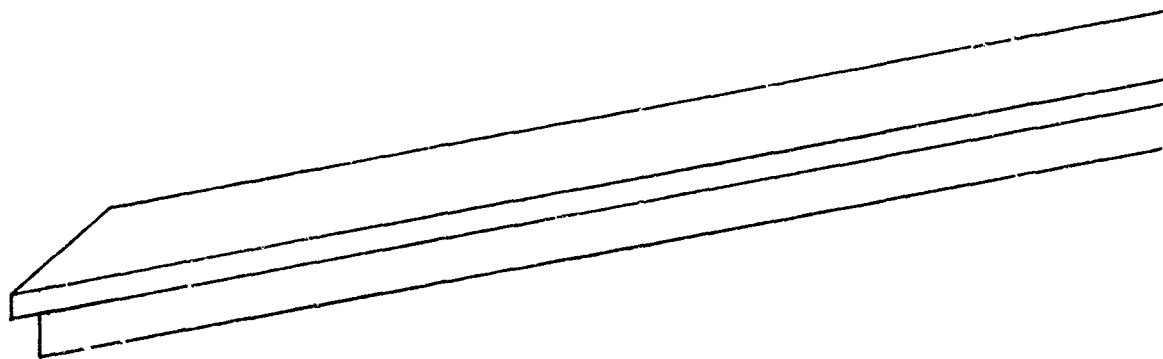

| SPECIMEN IDENTIFICATION | TYPE TEST | REFERENCE DWG. |
|-------------------------|--------------------------|----------------|
| M1, M2, M3 | TENSILE LONGITUDINAL | FIG. 1 |
| M4 THRU M7 | TENSILE TRANSVERSE | FIG. 1 |
| M8, M9, M10 | TENSILE LONGITUDINAL | FIG. 1 |
| M11 THRU M15 | FATIGUE SMOOTH $K_t=1.0$ | FIG. 2 |
| M16 THRU M24 | FRACTURE TOUGHNESS | FIG. 1 |
| M25, M26, M27 | DELAYED FAILURE | FIG. 1 |
| M28, M29, M30 | CHARPY TRANSVERSE | FIG. 1 |
| | CHARPY LONG | |



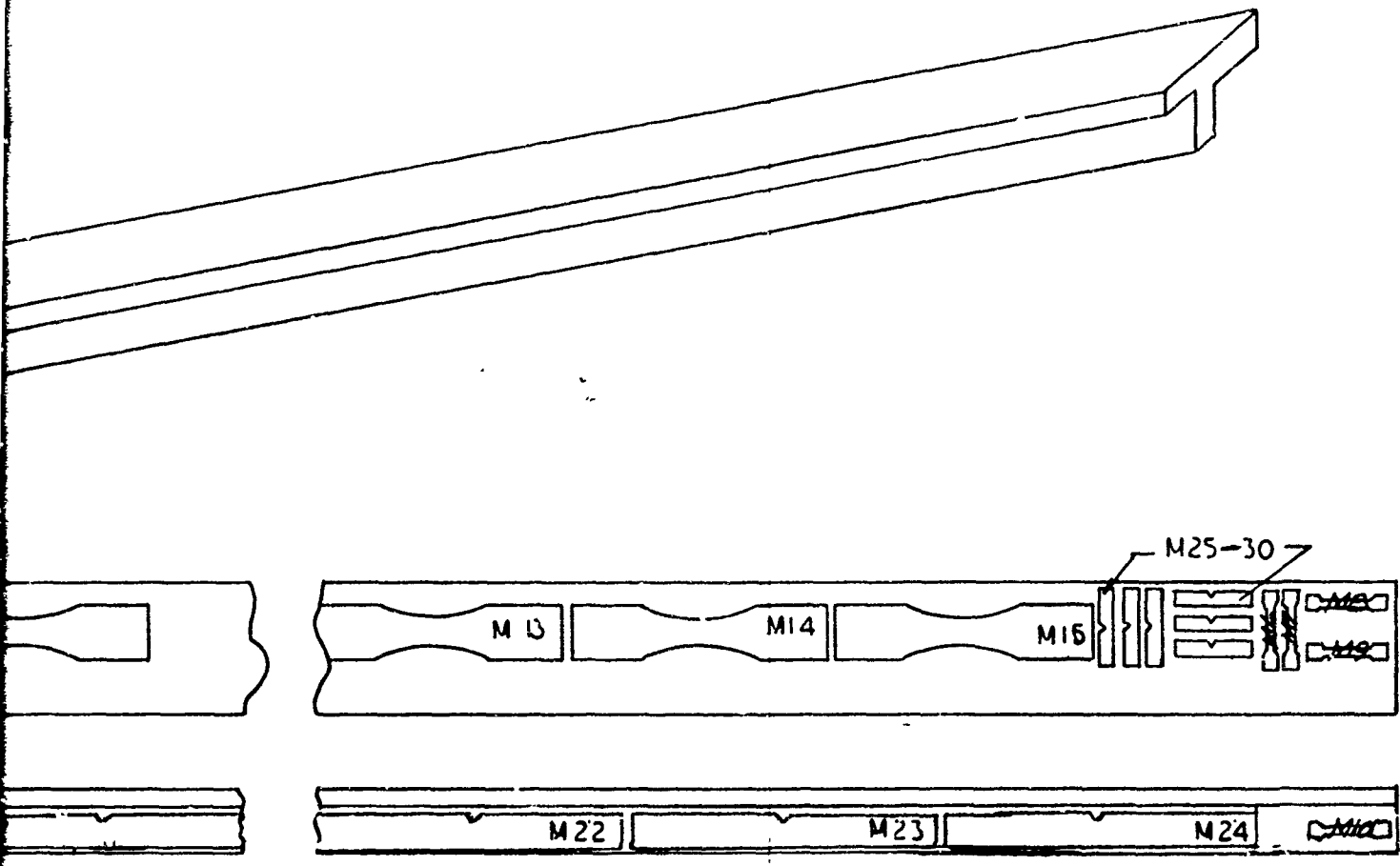

| SPECIMEN IDENTIFICATION | TYPE TEST | REFERENCE DWG. |
|--------------------------------|--|--------------------|
| M1, M2, M3 M4 THRU M7 | TENSILE LONGITUDINAL TENSILE TRANSVERSE | FIG. 10 FIG. 10 |
| M8, M9, M10 M11 THRU M15 | TENSILE LONGITUDINAL FATIGUE SMOOTH $K_t=1.0$ | FIG. 10 FIG. 20 |
| M16 THRU M24 | FRACTURE TOUGHNESS DELAYED FAILURE | FIG. 18 |
| M25, M26, M27 M28, M29, M30 | CHARPY TRANSVERSE CHARPY LONG | FIG. 16 FIG. 16 |

| PIECE | VENDOR | SPECIMEN CODE PREFIX | | |
|-------|--------|----------------------|----------|----------|
| | | Ti-6-4 | Ti-8-1-1 | Ti-6-6-2 |
| V | HARVEY | E | K | R |

2

Figure 94. Specimen Locations, Piece V, Thick Extrusion

TABLE XVII TENSILE TEST SUMMARY

| Alloy | Section | Specimen I.D. | Grain Dir. | Test Temp. (°F) | TUS (ksi) | TYS (ksi) | Elong. (%) | |
|--------|--------------|---------------|------------|-----------------|-----------|-----------|------------|----|
| Ti-6-4 | Thin (Fig.1) | AD25 | L | -110 | 173 | 157 | 12 | |
| | | AD26 | | | 174 | 164 | 12 | |
| | | AD27 | | | 172 | 163 | 12 | |
| | | CF1 | | | 179 | 162 | 12 | |
| | | CF2 | | | 174 | 162 | 14 | |
| | | CF3 | | | 174 | 162 | 13 | |
| | | AA1 | | | Room | 142 | 125 | 13 |
| | | AA2 | | | Room | 141 | 125 | 17 |
| | | AA3 | | | Room | 142 | 126 | 14 |
| | | AA4 | | | Room | 141 | 128 | 16 |
| | | AB1 | | Room | 144 | 127 | 16 | |
| | | AB2 | | Room | 142 | 126 | 15 | |
| | | AB3 | | Room | 141 | 124 | 15 | |
| | | AC1 | | Room | 145 | 130 | 14 | |
| | | AC2 | | Room | | | | |
| | | AC3 | | Room | 141 | 128 | 12 | |
| | | AC4 | | Room | 142 | 128 | 14 | |
| | | BH1 | | Room | 140 | 125 | 14 | |
| | | BH2 | | Room | 140 | 123 | 12 | |
| | | BH3 | | Room | 143 | 126 | 17 | |
| BH4 | Room | 141 | 124 | 16 | | | | |
| CA1 | Room | 147 | 130 | 14 | | | | |
| CA2 | Room | 143 | 125 | 16 | | | | |
| CA3 | Room | 146 | 129 | 15 | | | | |
| CA4 | Room | 143 | 127 | 18 | | | | |
| CB1 | Room | 145 | 135 | 13 | | | | |
| CB2 | Room | 144 | 128 | 15 | | | | |
| CB3 | Room | 144 | 128 | 16 | | | | |
| Ti-6-4 | Thin (Fig.1) | CC1 | L | Room | 143 | 128 | 14 | |

TABLE XVII TENSILE TEST SUMMARY (Continued)

| Alloy | Section | Specimen I.D. | Grain Dir. | Test Temp. (°F) | TUS (ksi) | TYS (ksi) | Elong. (%) | |
|--------|---------------|---------------|------------|-----------------|-----------|-----------|------------|----|
| Ti-6-4 | Thin (Fig. 1) | CC2 | L | Room | 146 | 129 | 11 | |
| | | CC3 | | | 146 | 131 | 15 | |
| | | CC4 | | 144 | 130 | 16 | | |
| | | DH1 | | 146 | 132 | 16 | | |
| | | DH2 | | 143 | 127 | 16 | | |
| | | DH3 | | 145 | 130 | 16 | | |
| | | DH4 | | Room | 149 | 136 | 14 | |
| | | AD28 | | 400 | 110 | 90 | 15 | |
| | | AD29 | | ↑ | 112 | | 16 | |
| | | AD30 | | ↓ | 110 | 88 | 20 | |
| | | CF4 | | ↑ | 113 | 93 | 20 | |
| | | CF5 | | ↓ | 113 | 94 | 18 | |
| | | CF6 | | 400 | 112 | 92 | 20 | |
| | | AD31 | | 600 | 100 | 76 | 16 | |
| | | AD32 | | ↑ | 103 | 77 | 16 | |
| | | AD33 | | ↓ | 100 | 79 | 17 | |
| | | CF7 | | ↑ | 102 | 79 | 18 | |
| | | CF8 | | ↓ | 101 | 72 | 18 | |
| | | CF9 | | 600 | 101 | 80 | 17 | |
| | | AD34 | | 500 | 92 | 73 | 17 | |
| | | AD35 | | ↑ | 93 | 73 | 17 | |
| | | AD36 | | ↓ | 93 | 73 | 16 | |
| | | CF10 | | ↑ | 96 | 73 | 14 | |
| | | CF11 | | ↓ | 95 | 75 | 19 | |
| | | CF12 | | L | 800 | 94 | 73 | 18 |
| | | AD1 | | T | -110 | 170 | 160 | 12 |
| AD2 | ↑ | ↑ | 172 | 162 | 11 | | | |
| AD3 | ↓ | ↓ | -110 | 169 | 161 | 11 | | |
| Ti-6-4 | Thin (Fig. 1) | AA9 | T | Room | 142 | 127 | 14 | |

TABLE XVII TENSILE TEST SUMMARY (Continued)

| Alloy | Section | Specimen I.D. | Grain Dir. | Test Temp. (°F) | TUS (ksi) | YYS (ksi) | Elong. (%) |
|--------|--------------|---------------|------------|-----------------|-----------|-----------|------------|
| Ti-6-4 | Thin (Fig.1) | AA10 | T | Room | 142 | 128 | 14 |
| | | AA11 | | | 141 | 126 | 14 |
| | | AB7 | | | 142 | 127 | 13 |
| | | AB8 | | | 143 | 127 | 14 |
| | | AB9 | | | 143 | 128 | 11 |
| | | AC8 | | | 141 | 127 | 14 |
| | | AC9 | | | 142 | 126 | 13 |
| | | AC10 | | | 142 | 127 | 15 |
| | | BH5 | | | 143 | 126 | 15 |
| | | BH6 | | | 142 | 126 | 14 |
| | | BH7 | | | 145 | 129 | 14 |
| | | BJ1 | | | 141 | 124 | 11 |
| | | BJ2 | | | 145 | 130 | 15 |
| | | BJ3 | | | 140 | 125 | 15 |
| | | CA9 | | | 145 | 129 | 15 |
| | | CA10 | | | 146 | 130 | 14 |
| | | CA11 | | | 146 | 130 | 14 |
| | | CF7 | | | 145 | 130 | 15 |
| | | CB8 | | | 146 | 129 | 15 |
| | | CB9 | | | 146 | 130 | 14 |
| | | CC8 | | | 146 | 131 | 15 |
| | | CC9 | | | 145 | 128 | 14 |
| | | CC10 | | | 146 | 129 | 14 |
| | | DH5 | | | 146 | 130 | 13 |
| | | DH6 | | | 146 | 129 | 14 |
| | | DH7 | | | 146 | 130 | 14 |
| DJ1 | 146 | 130 | 17 | | | | |
| DJ2 | 150 | 133 | 14 | | | | |
| Ti-6-4 | Thin (Fig.1) | DJ3 | T | Room | 144 | 128 | 14 |

TABLE XVII TENSILE TEST SUMMARY (Continued)

| Alloy | Section | Specimen I.D. | Grain Dir. | Test Temp. (°F) | TUS (ksi) | TYS (ksi) | Elong. (%) | |
|----------|---------------|---------------|------------|-----------------|-----------|-----------|------------|----|
| Ti-6-4 | Thin (Fig.1) | AD4 | T | 400 | 109 | 86 | 16 | |
| | | AD5 | T | 400 | 110 | 88 | 16 | |
| | | AD6 | T | 400 | 111 | 90 | 15 | |
| | | AD7 | T | 600 | 102 | 78 | 15 | |
| | | AD8 | T | 600 | 103 | 79 | 17 | |
| | | AD9 | T | 600 | 103 | 80 | 16 | |
| | Thick (Fig.2) | AD10 | T | 800 | 93 | 71 | 16 | |
| | | AD11 | T | 800 | 93 | 72 | 16 | |
| | | AD12 | T | 800 | 94 | 72 | 16 | |
| | | EM1 | L | Room | 143 | 129 | 14 | |
| | | EM2 | L | Room | 140 | 125 | 14 | |
| | | EM3 | L | Room | 141 | 126 | 14 | |
| Ti-6-4 | Thick (Fig.2) | EM8 | L | Room | 144 | 130 | 14 | |
| | | EM9 | L | Room | 141 | 127 | 14 | |
| | | EM10 | L | Room | 142 | 128 | 14 | |
| | | EM4 | T | Room | 143 | 130 | 14 | |
| | | EM5 | T | Room | 142 | 133 | 14 | |
| | | EM6 | T | Room | 144 | 131 | 14 | |
| | Ti-8-1-1 | Thin (Fig.1) | EM7 | T | Room | 144 | 130 | 14 |
| | | | FD25 | L | -110 | 170 | 161 | 12 |
| | | | FD26 | L | -110 | 167 | 159 | 12 |
| | | | FD27 | L | -110 | 168 | 161 | 12 |
| | | | HF1 | L | -110 | 155 | 143 | 16 |
| | | | HF2 | L | -110 | 156 | 142 | 14 |
| Ti-8-1-1 | Thin (Fig.1) | HF3 | L | -110 | 156 | 143 | 16 | |
| | | FA1 | L | Room | 138 | 125 | 13 | |
| | | FA2 | L | Room | 135 | 121 | 16 | |
| | | FA3 | L | Room | 141 | 126 | 13 | |
| | | FA4 | L | Room | 138 | 123 | 14 | |

TABLE XVII TENSILE TEST SUMMARY (Continued)

| Alloy | Section | Specimen I.D. | Grain Dir. | Test Temp. (°F) | TUS (ksi) | TYS (ksi) | Elong. (%) | |
|---------------|-------------------|---------------|------------|-----------------|-----------|-----------|------------|----|
| Ti-8-1-1 ↑ | Thin (Fig.1) ↑ | FB1 | L ↑ | Room ↑ | 141 | 125 | 15 | |
| | | FB2 | | | 135 | 121 | 18 | |
| | | FB3 | | | 137 | 121 | 15 | |
| | | FC1 | | | 144 | 129 | 15 | |
| | | FC2 | | | 134 | 121 | 18 | |
| | | FC3 | | | 141 | 126 | 15 | |
| | | FC4 | | | 141 | 127 | 15 | |
| | | GH1 | | | 134 | 118 | 21 | |
| | | GH2 | | | 144 | 127 | 16 | |
| | | GH3 | | | 143 | 124 | 19 | |
| | | GH4 | | | 139 | 122 | 19 | |
| | | HA1 | | | 134 | 118 | 15 | |
| | | HA2 | | | 129 | 114 | 18 | |
| | | HA3 | | | 136 | 122 | 18 | |
| | | HA4 | | | 134 | 121 | 17 | |
| | | HB1 | | | 134 | 119 | 17 | |
| | | HB2 | | | 131 | 116 | 16 | |
| | | HB3 | | | 134 | 120 | 16 | |
| | | HC1 | | | 134 | 120 | 16 | |
| | | HC2 | | | 131 | 116 | 17 | |
| | | HC3 | | | 137 | 124 | 16 | |
| | | HC4 | | | 132 | 118 | 16 | |
| | | JH1 | | | 136 | 122 | 18 | |
| | | JH2 | | | 133 | 119 | 16 | |
| | | JH3 | | | 134 | 119 | 13 | |
| | | JH4 | | | Room | 135 | 121 | 18 |
| | | FD28 | | | 400 | 115 | 89 | 18 |
| FD29 | 400 | 115 | 89 | 18 | | | | |
| Ti-8-1-1 ↓ | Thin (Fig.1) ↓ | FD30 | L ↓ | 400 | 115 | 88 | 19 | |

TABLE XVII TENSILE TEST SUMMARY (Continued)

| Alloy | Section | Specimen I.D. | Grain Dir. | Test Temp. (°F) | TUS (ksi) | TYS (ksi) | Elong. (%) |
|----------|--------------|---------------|------------|-----------------|-----------|-----------|------------|
| Ti-8-1-1 | Thin (Fig.1) | HF4 | L | 400 | 106 | 85 | 20 |
| | | HF5 | | ↕ | 105 | 86 | 19 |
| | | HF6 | | 400 | 106 | 35 | 19 |
| | | FD31 | | 600 | 107 | 81 | 18 |
| | | FD32 | | ↕ | 108 | 80 | 20 |
| | | FD33 | | ↕ | 108 | 81 | 20 |
| | | HF7 | | ↕ | 95 | 65 | 19 |
| | | HF8 | | ↕ | 96 | 72 | 23 |
| | | HF9 | | 600 | 94 | 70 | 19 |
| | | FD34 | | 800 | 99 | 72 | 19 |
| | | FD35 | | ↕ | 99 | 72 | 20 |
| | | FD36 | | ↕ | 99 | 73 | 20 |
| | HF10 | ↕ | 88 | 64 | 20 | | |
| | HF11 | ↕ | 88 | 62 | 23 | | |
| | HF12 | L | 800 | 89 | 64 | 19 | |
| | FD25 | T | -110 | 170 | 161 | 12 | |
| | FD26 | ↕ | ↕ | 167 | 159 | 12 | |
| | FD27 | ↕ | -110 | 168 | 161 | 12 | |
| | FA9 | ↕ | Room | 137 | 122 | 12 | |
| | FA10 | ↕ | ↕ | 138 | 124 | 15 | |
| | FA11 | ↕ | ↕ | 138 | 126 | 16 | |
| | FB7 | ↕ | ↕ | 138 | 123 | 15 | |
| | FB8 | ↕ | ↕ | 137 | 122 | 15 | |
| | FB9 | ↕ | ↕ | 136 | 122 | 15 | |
| | FC8 | ↕ | ↕ | 136 | 120 | 15 | |
| | FC9 | ↕ | ↕ | 136 | 121 | 15 | |
| FC10 | ↕ | ↕ | 138 | 123 | 16 | | |
| GH5 | ↕ | ↕ | 137 | 120 | 17 | | |
| Ti-8-1-1 | Thin (Fig.1) | GH6 | T | Room | 137 | 121 | 17 |

TABLE XVII TENSILE TEST SUMMARY (Continued)

| Alloy | Section | Specimen I.D. | Grain Dir. | Test Temp. (°F) | TUS (ksi) | TYS (ksi) | Elong. (%) |
|----------|--------------|---------------|------------|-----------------|-----------|-----------|------------|
| Ti-8-1-1 | Thin (Fig.1) | GH7 | T | Room | 138 | 120 | 17 |
| | | GJ1 | | | 138 | 121 | 15 |
| | | GJ2 | | | 137 | 120 | 15 |
| | | GJ3 | | | 138 | 122 | 15 |
| | | HA9 | | | 133 | 118 | 14 |
| | | HA10 | | | 134 | 119 | 14 |
| | | HA11 | | | 133 | 118 | |
| | | HB7 | | | 133 | 118 | |
| | | HB8 | | | 132 | 117 | |
| | | HB9 | | | 132 | 117 | |
| | HC8 | 132 | | 116 | | | |
| | HC9 | 132 | | 117 | | | |
| | HC10 | 132 | | 117 | | | |
| | JH5 | 136 | | 123 | | | |
| | JH6 | 134 | | 119 | | | |
| | JH7 | 134 | | 119 | | | |
| | JJ1 | 133 | | 117 | | | |
| | JJ2 | 132 | | 116 | | | |
| | JJ3 | Room | | 133 | 118 | | |
| | FD4 | 400 | | 113 | 89 | 18 | |
| FD5 | 400 | 112 | 88 | 18 | | | |
| FD6 | 400 | 114 | 90 | 18 | | | |
| FD7 | 600 | 106 | 80 | 20 | | | |
| FD8 | 600 | 103 | 78 | 16 | | | |
| FD9 | 600 | 105 | 80 | 18 | | | |
| FD10 | 800 | 96 | 72 | 18 | | | |
| FD11 | 800 | 93 | 69 | 18 | | | |
| FD12 | 800 | 95 | 72 | 20 | | | |
| Ti-8-1-1 | Thin (Fig.1) | | | | | | |

TABLE XVII TENSILE TEST SUMMARY (Continued)

| Alloy | Section | Specimen I.D. | Grain Dir. | Test Temp. (°F) | TUS (ksi) | TYS (ksi) | Elong. (%) |
|----------|---------------|---------------|------------|-----------------|-----------|-----------|------------|
| Ti-8-1-1 | Thick (Fig.2) | KM1 | L | Room | 138 | 126 | 12 |
| | | KM2 | L | | 132 | 119 | 14 |
| | | KM3 | L | | 134 | 122 | 15 |
| | | KM8 | L | | 138 | 126 | 15 |
| | | KM9 | L | | 133 | 121 | 15 |
| | | KM10 | L | | 132 | 120 | 15 |
| | | KM4 | T | | 136 | 123 | 15 |
| | | KM5 | T | | 136 | 123 | 13 |
| | | KM6 | T | | 136 | 123 | 14 |
| | | KM7 | T | | 138 | 127 | 15 |
| Ti-8-1-1 | Thick (Fig.2) | LD25 | L | Room | 190 | 180 | 9 |
| Ti-6-6-2 | Thin (Fig.1) | LD26 | L | -110 | 189 | 178 | 9 |
| | | LD27 | L | -110 | 187 | 177 | 11 |
| | | NF1 | L | -110 | 172 | 162 | 13 |
| | | NF2 | L | -110 | 173 | 162 | 12 |
| | | NF3 | L | -110 | 173 | 162 | 14 |
| | | LA1 | L | Room | 157 | 140 | 15 |
| | | LA2 | L | Room | 154 | 138 | 14 |
| | | LA3 | L | Room | 157 | 140 | 15 |
| | | LA4 | L | Room | 164 | 144 | 15 |
| | | LB1 | L | Room | 158 | 139 | 15 |
| | | LB2 | L | Room | 157 | 132 | 14 |
| | | LB3 | L | Room | 156 | - | 15 |
| | | LC1 | L | Room | 159 | 142 | 13 |
| | | LC2 | L | Room | 158 | 140 | 14 |
| | | LC3 | L | Room | 159 | 143 | 13 |
| | | LC4 | L | Room | 158 | 141 | 14 |
| | | MH1 | L | Room | 160 | 140 | 16 |
| | | MH2 | L | Room | 158 | 138 | 16 |

TABLE XVII TENSILE TEST SUMMARY (Continued)

| Alloy | Section | Specimen I.D. | Grain Dir. | Test Temp. (°F) | TUS (ksi) | TYS (ksi) | Elong. (%) | |
|----------|--------------|---------------|------------|-----------------|-----------|-----------|------------|----|
| Ti-6-6-2 | Thin (Fig.1) | MH3 | L | Room | 154 | 136 | 15 | |
| | | MH4 | | | 157 | 137 | 17 | |
| | | NA1 | | | 153 | 136 | 15 | |
| | | NA2 | | | 147 | 134 | 16 | |
| | | NA3 | | | 147 | 133 | 18 | |
| | | NA4 | | | 150 | 135 | 17 | |
| | | NB1 | | | 146 | 132 | 15 | |
| | | NB2 | | | 143 | 131 | 17 | |
| | | NB3 | | | 146 | 133 | 18 | |
| | | NC1 | | | 148 | 134 | 15 | |
| | | NC2 | | | 145 | 132 | 17 | |
| | | NC3 | | | 150 | 135 | 16 | |
| | | NC4 | | | 145 | 132 | 17 | |
| | | PH1 | | | 145 | 134 | 20 | |
| | | PH2 | | | 142 | 131 | 21 | |
| | | PH3 | | | 146 | 135 | 18 | |
| | | PH4 | | | 147 | 136 | 19 | |
| | | LD28 | | | 400 | 125 | 101 | 16 |
| | | LD29 | | | 400 | 125 | 100 | 17 |
| | | LD30 | | | 400 | 126 | 100 | 17 |
| | | NF4 | | | 400 | 125 | 104 | 18 |
| | | NF5 | | | 400 | 125 | 105 | 21 |
| | | NF6 | | | 400 | 125 | 104 | 20 |
| | | LD31 | | | 600 | 121 | 100 | 19 |
| | | LD32 | | | 600 | 121 | 94 | 18 |
| | | LD33 | | | 600 | 121 | 95 | 17 |
| | | NF7 | | | 600 | 116 | 93 | 17 |
| NF8 | 600 | 117 | 93 | 19 | | | | |
| NF9 | 600 | 115 | 92 | 16 | | | | |

TABLE XVII TENSILE TEST SUMMARY (Continued)

| Alloy | Section | Specimen I.D. | Grain Dir. | Test Temp. (°F) | TUS (ksi) | TYS (ksi) | Elong. (%) |
|----------|--------------|---------------|------------|-----------------|-----------|-----------|------------|
| Ti-6-6-2 | Thin (Fig.1) | LD34 | L | 800 | 108 | 86 | 17 |
| | | LD35 | ↑ | ↑ | 108 | 86 | 24 |
| | | LD36 | ↓ | ↓ | 110 | 88 | 18 |
| | | NF10 | ↓ | ↓ | 108 | 89 | 19 |
| | | NF11 | ↓ | ↓ | 107 | 86 | 17 |
| | | NF12 | L | 800 | 108 | 89 | 17 |
| | | LD1 | T | -110 | 191 | 180 | 9 |
| | | LD2 | ↑ | ↑ | 190 | 181 | 9 |
| | | LD3 | ↓ | ↓ | 193 | 182 | 9 |
| | | LA9 | ↑ | Room | 160 | 139 | 11 |
| | | LA10 | ↑ | ↑ | 157 | 140 | 11 |
| | | LA11 | ↑ | ↑ | 159 | 142 | 13 |
| | LB7 | ↑ | ↑ | 160 | 141 | 15 | |
| | LB8 | ↑ | ↑ | 159 | 141 | 12 | |
| | LB9 | ↑ | ↑ | 160 | 145 | 14 | |
| | LC8 | ↑ | ↑ | 160 | 145 | 13 | |
| | LC9 | ↑ | ↑ | 161 | 146 | 13 | |
| | LC10 | ↑ | ↑ | 157 | 142 | 14 | |
| | MH5 | ↑ | ↑ | 159 | 139 | 14 | |
| | MH6 | ↑ | ↑ | 160 | 141 | 15 | |
| | MH7 | ↑ | ↑ | 159 | 140 | 15 | |
| | MJ1 | ↑ | ↑ | 161 | 143 | 14 | |
| | MJ2 | ↑ | ↑ | 161 | 143 | 14 | |
| | MJ3 | ↑ | ↑ | 159 | 141 | 13 | |
| | NA9 | ↑ | ↑ | 152 | 136 | 16 | |
| | NA10 | ↑ | ↑ | 153 | 137 | 17 | |
| | NA11 | ↑ | ↑ | 152 | 137 | 15 | |
| | NB7 | ↑ | ↑ | 151 | 135 | 15 | |
| NB8 | Thin (Fig.1) | T | Room | 150 | 135 | 17 | |

TABLE XVII TENSILE TEST SUMMARY (Concluded)

| Alloy | Section | Specimen I.D. | Grain Dir. | Test Temp. (°F) | TUS (ksi) | TYS (ksi) | Elong. (%) | |
|----------|-------------------------------|---------------|------------|-----------------|-----------|-----------|------------|-----|
| Ti-6-6-2 | Thin (Fig.1) | NB9 | T | Room | 151 | 135 | 16 | |
| | | NC8 | ↑ | ↑ | 150 | 134 | 15 | |
| | | NC9 | | | 150 | 136 | 15 | |
| | | NC10 | | | 151 | 135 | 15 | |
| | | PH5 | | | 148 | 134 | 18 | |
| | | PH6 | | | 148 | 134 | 19 | |
| | | PH7 | | | 148 | 133 | 16 | |
| | | PJ1 | | | 149 | 133 | 17 | |
| | | PJ2 | | | 150 | 136 | 16 | |
| | | PJ3 | | | Room | 150 | 136 | 17 |
| | Thin (Fig.1) Thick (Fig.2) | LD4 | | | 400 | 134 | 107 | 16 |
| | | LD5 | | | 400 | 132 | 108 | 14 |
| | | LD6 | | | 400 | 133 | 108 | 14 |
| | | LD7 | | | 600 | 126 | 98 | 15 |
| | | LD8 | | | 600 | 127 | 100 | 14 |
| | | LD9 | | | 600 | 125 | 98 | 15 |
| | | LD10 | | | 800 | 114 | 91 | 18 |
| | | LD11 | | | 800 | 114 | 91 | 16 |
| | | LD12 | | T | 800 | 115 | 92 | 16 |
| | | Thick (Fig.2) | RM1 | | L | Room | 157 | 142 |
| RM2 | | | ↑ | ↑ | 156 | 138 | 13 | |
| RM3 | | | | | 154 | 137 | 15 | |
| RM8 | | | | | 156 | 140 | 13 | |
| RM9 | | | | | 154 | 136 | 15 | |
| RM10 | | | L | | 154 | 137 | 14 | |
| RM4 | | | T | | 161 | 144 | 13 | |
| RM5 | | ↑ | | 161 | 145 | 13 | | |
| RM6 | | | | | 160 | 145 | 12 | |
| Ti-6-6-2 | Thick (Fig.2) | RM7 | T | Room | 162 | 148 | 11 | |

TABLE XVIII COMPRESSION TEST SUMMARY

| Alloy | Section | Specimen I.D. | Grain Direct. | Test Temp (°F) | CYS 0.2% (ksi) |
|--------|---------------|---------------|---------------|----------------|----------------|
| Ti-6-4 | Thin (Fig. 1) | AD37 | L | -110 | --- |
| | | AD38 | | | 172 |
| | | AD39 | | | 174 |
| | | CF13 | | | 179 |
| | | CF14 | | | 171 |
| | | CF15 | | -110 | 171 |
| | | AA5 | | Room | --- |
| | | AA6 | | | 137 |
| | | AA7 | | | 139 |
| | | AA8 | | | 137 |
| | | AB4 | | | 139 |
| | | AB5 | | | 139 |
| | | AB6 | | | 137 |
| | | AC5 | | | 139 |
| | | AC6 | | | 138 |
| | | AC7 | | | 139 |
| | | CA5 | | | 142 |
| | | CA6 | | | 140 |
| | | CA7 | | | 142 |
| | | CA8 | | | 142 |
| | | CB4 | | | 142 |
| | | CB5 | | | 142 |
| | | CB6 | | | 142 |
| | | CC5 | | | --- |
| | | CC6 | | | 140 |
| | | CC7 | | Room | 141 |
| | | AD40 | | 400 | 92 |
| Ti-6-4 | Thin (Fig. 1) | AD41 | L | 400 | 93 |

TABLE XVIII COMPRESSION TEST SUMMARY (Continued)

| Alloy | Section | Specimen I.D. | Grain Direct. | Test Temp (°F) | CYS 0.2% (ksi) | |
|--------|---------------|---------------|---------------|----------------|----------------|--|
| Ti-6-4 | Thin (Fig. 1) | AD42 | L | 400 | 93 | |
| | | CF16 | | 400 | 97 | |
| | | CF17 | | 400 | 99 | |
| | | CF18 | | 400 | 100 | |
| | | AD43 | | 600 | 80 | |
| | | AD44 | | 600 | 78 | |
| | | AD45 | | 600 | 80 | |
| | | CF19 | | 600 | 83 | |
| | | CF20 | | 600 | 83 | |
| | | CF21 | | 600 | 84 | |
| | | AD46 | | 800 | 79 | |
| | | AD47 | | 800 | --- | |
| | | AD48 | | 800 | 76 | |
| | | CF22 | | 800 | 78 | |
| | | CF23 | | 800 | 77 | |
| | | CF24 | | 800 | 79 | |
| | AD13 | -110 | 173 | | | |
| | AD14 | -110 | 172 | | | |
| | AD15 | -110 | 176 | | | |
| | AA12 | Room | 139 | | | |
| | AA13 | Room | 139 | | | |
| | AA14 | Room | 138 | | | |
| | AB10 | Room | 139 | | | |
| | AB11 | Room | 138 | | | |
| | AB12 | Room | 140 | | | |
| | AB13 | Room | 142 | | | |
| | AC11 | Room | 138 | | | |
| | AC12 | Room | 138 | | | |
| | AC13 | Room | 139 | | | |
| | Ti-6-4 | Thin (Fig. 1) | | T | | |

TABLE XVIII COMPRESSION TEST SUMMARY (Continued)

| Alloy | Section | Specimen I.D. | Grain Direct. | Test Temp (°F) | CYS 0.2% (ksi) |
|----------|---------------|---------------|---------------|----------------|----------------|
| Ti-6-4 | Thin | CA12 | T | Room | 144 |
| | | CA13 | | | 147 |
| | | CA14 | | | 145 |
| | | CB10 | | | 146 |
| | | CB11 | | | 145 |
| | | CB12 | | | 143 |
| | | CB13 | | | 142 |
| | | CC11 | | | 144 |
| | | CC12 | | | 143 |
| | | CC13 | | Room | 146 |
| | | AD16 | | 400 | 95 |
| | | AD17 | | ↕ | 96 |
| | | AD18 | | 400 | 96 |
| | | AD19 | | 600 | 82 |
| | | AD20 | | ↕ | 82 |
| | | AD21 | | 600 | 82 |
| | | AD22 | | 800 | 77 |
| | | AD23 | | ↕ | 77 |
| | | AD24 | T | 800 | 78 |
| Ti-6-4 | | FD37 | L | -110 | 169 |
| Ti-8-1-1 | | FD38 | | | 167 |
| | | FD39 | | | 174 |
| | | HF13 | | | 162 |
| | | HF14 | | | --- |
| | | HF15 | | -110 | 163 |
| | | FA5 | | Room | 137 |
| | | FA6 | | ↕ | 135 |
| Ti-8-1-1 | Thin (Fig. 1) | FA7 | L | Room | 139 |

TABLE XVIII COMPRESSION TEST SUMMARY (Continued)

| Alloy | Section | Specimen I.D. | Grain Direct. | Test Temp (OF) | CYS 0.2% (ksi) |
|----------|---------------|---------------|---------------|----------------|----------------|
| Ti-8-1-1 | Thin (Fig. 1) | FA8 | L | Room | 134 |
| | | FB4 | | | 137 |
| | | FB5 | | | 135 |
| | | FB6 | | | 136 |
| | | FC5 | | | 140 |
| | | FC6 | | | 131 |
| | | FC7 | | | 138 |
| | | HA5 | | | 132 |
| | | HA6 | | | 129 |
| | | HA7 | | | 133 |
| | | HA8 | | | 131 |
| | | HB4 | | | 128 |
| | | HB5 | | | 131 |
| | | HB6 | | | 132 |
| | | HC5 | | 130 | |
| | | HC6 | | 128 | |
| | | HC7 | | 132 | |
| | | FD40 | | 400 | 99 |
| | | FD41 | | 400 | 96 |
| | | FD42 | | 400 | 98 |
| | | HF16 | | 400 | 92 |
| HF17 | 400 | 92 | | | |
| HF18 | 400 | 91 | | | |
| FD43 | 600 | 82 | | | |
| FD44 | 600 | 83 | | | |
| FD45 | 600 | 82 | | | |
| HF19 | 600 | 77 | | | |
| HF20 | 600 | 77 | | | |
| HF21 | 600 | 77 | | | |
| Ti-8-1-1 | Thin (Fig. 1) | | L | 600 | 77 |

TABLE XVIII COMPRESSION TEST SUMMARY (Continued)

| Alloy | Section | Specimen I.D. | Grain Direct. | Test Temp (°F) | CYS 0.2% (ksi) |
|----------|---------------|---------------|---------------|----------------|----------------|
| Ti-8-1-1 | Thin (Fig. 1) | FD46 | L | 800 | 78 |
| | | FD47 | L | 800 | 78 |
| | | FD48 | L | 800 | 77 |
| | | HF22 | L | 800 | 70 |
| | | HF23 | L | 800 | 70 |
| | | HF24 | L | 800 | 70 |
| | | FD13 | T | -110 | 173 |
| | | FD14 | T | -110 | 173 |
| | | FD15 | T | -110 | --- |
| | | FA12 | T | Room | 140 |
| | | FA13 | T | Room | 138 |
| | | FA14 | T | Room | 138 |
| | | FB10 | T | Room | 137 |
| | | FB11 | T | Room | 138 |
| | | FB12 | T | Room | 138 |
| | | FB13 | T | Room | 139 |
| | | FC11 | T | Room | 139 |
| | | FC12 | T | Room | 139 |
| | | FC13 | T | Room | 139 |
| | | HA12 | T | Room | 135 |
| | | HA13 | T | Room | 136 |
| | | HA14 | T | Room | 134 |
| | | HB10 | T | Room | 133 |
| | | HB11 | T | Room | 132 |
| | | HB12 | T | Room | 133 |
| | | HB13 | T | Room | 132 |
| | | HC11 | T | Room | 132 |
| | | HC12 | T | Room | 135 |

TABLE XVIII COMPRESSION TEST SUMMARY (Continued)

| Alloy | Section | Specimen I.D. | Grain Direct. | Test Temp (°F) | CYS 0.2% (ksi) |
|----------|---------------|---------------|---------------|----------------|----------------|
| Ti-8-1-1 | Thin (Fig. 1) | HC13 | T | Room | 133 |
| | | FD16 | | 400 | 100 |
| | | FD17 | | 400 | 98 |
| | | FD18 | | 400 | 98 |
| | | FD19 | | 600 | 84 |
| | | FD20 | | 600 | --- |
| | | FD21 | | 600 | 84 |
| | | FD22 | | 800 | 79 |
| | | FD23 | | 800 | 80 |
| | | FD24 | | 800 | 75 |
| Ti-8-1-1 | | LD37 | L | -110 | 194 |
| Ti-6-6-2 | | LD38 | | | 196 |
| | | LD39 | | | 196 |
| | | NF13 | | | 182 |
| | | NF14 | | | 186 |
| | | NF15 | | | -110 |
| | | LA5 | | | Room |
| | | LA6 | | | 154 |
| | | LA7 | | | 154 |
| | | LA8 | | | 153 |
| | | LB4 | | 156 | |
| | | LB5 | | 152 | |
| | | LB6 | | 154 | |
| | | LC5 | | 156 | |
| | | LC6 | | 155 | |
| | | LC7 | | 156 | |
| | | NA5 | | 147 | |
| | | NA6 | | 148 | |
| Ti-6-6-2 | Thin (Fig. 1) | NA7 | L | Room | 150 |

TABLE XVIII. COMPRESSION TEST SUMMARY (Continued)

| Alloy | Section | Specimen I.D. | Grain Direct. | Test Temp (°F) | CYS 0.2% (ksi) |
|----------|---------------|---------------|---------------|----------------|----------------|
| Ti-6-6-2 | Thin (Fig. 1) | NA8 | L | Room | 148 |
| | | NB4 | | 148 | |
| | | NB5 | | 147 | |
| | | NB6 | | 149 | |
| | | NC5 | | 149 | |
| | | NC6 | | 146 | |
| | | NC7 | | Room | 148 |
| | | LD40 | | 400 | --- |
| | | LD41 | | 114 | |
| | | LD42 | | 114 | |
| | | NF16 | | 111 | |
| | | NF17 | | 110 | |
| | | NF18 | | 110 | |
| | | LD43 | | 600 | 102 |
| | | LD44 | | 104 | |
| | | LD45 | | 102 | |
| | | NF19 | | 102 | |
| | | NF20 | | 101 | |
| | | NF21 | | 600 | 101 |
| | | LD46 | | 800 | 94 |
| | | LD47 | | 96 | |
| | | LD48 | | 97 | |
| | | NF22 | 96 | | |
| | | NF23 | 95 | | |
| NF24 | 800 | 95 | | | |
| LD13 | -110 | 201 | | | |
| LD14 | 199 | | | | |
| LD15 | -110 | 202 | | | |
| Ti-6-6-2 | Thin (Fig. 1) | | L | | |
| | | | T | | |
| | | | T | | |

TABLE XVIII COMPRESSION TEST SUMMARY (Concluded)

| Alloy | Section | Specimen I.D. | Grain Direct. | Test Temp (°F) | CYS 0.2% (ksi) |
|----------|---------------|---------------|---------------|----------------|----------------|
| Ti-6-6-2 | Thin (Fig. 1) | LA12 | T | Room | 159 |
| | | LA13 | | | 158 |
| | | LA14 | | | 160 |
| | | LB10 | | | 157 |
| | | LB11 | | | 155 |
| | | LB12 | | | 157 |
| | | LB13 | | | 159 |
| | | LC11 | | | 158 |
| | | LC12 | | | 161 |
| | | LC13 | | | 157 |
| | | NA12 | | | 152 |
| | | NA13 | | | 154 |
| | NA14 | 153 | | | |
| | NB10 | --- | | | |
| | NB11 | 151 | | | |
| | NB12 | 149 | | | |
| | NB13 | 153 | | | |
| | NC11 | 151 | | | |
| | NC12 | 148 | | | |
| | NC13 | 149 | | | |
| | LD16 | 400 | | | |
| | LD17 | 400 | | | |
| | LD18 | 400 | | | |
| | LD19 | 600 | | | |
| LD20 | 600 | | | | |
| LD21 | 600 | | | | |
| LD22 | 800 | | | | |
| LD23 | 800 | | | | |
| Ti-6-6-2 | Thin (Fig. 1) | ID24 | T | 800 | 98 |

TABLE XIX TENSILE MODULUS SUMMARY

| Alloy | Specimen Number | E_t ($\times 10^6$ psi) | |
|----------|-----------------|-------------------------------|------|
| Ti-6-4 | AA2 | 16.8 | |
| | AB2 | 16.9 | |
| | AC1 | 17.0 | |
| | Average | | 16.9 |
| Ti-8-1-1 | FA2 | 17.5 | |
| | FB2 | 17.6 | |
| | FC2 | 17.6 | |
| | Average | | 17.6 |
| Ti-6-6-2 | LA2 | 16.3 | |
| | LB2 | 15.8 | |
| | LC2 | 16.2 | |
| | Average | | 16.1 |

ROOM TEMPERATURE, LONGITUDINAL SPECIMENS

TABLE XX BEARING TEST SUMMARY

| Alloy | Specimen ID | Test Temp. | Grain Direction | e/D | Ultimate Bearing Strength(ksi) | Bearing Yield Strength(ksi) |
|--------|-------------|------------|-----------------|-----|--------------------------------|-----------------------------|
| Ti-6-4 | AD49 | -110°F | L | 2.0 | 329 | 294 |
| | AD50 | ↓ | | | △ | △ |
| | AD51 | -110°F | | | 332 | 299 |
| | AVG | | | | 330 | 296 |
| | AD52 | RT | | | △ | △ |
| | AD53 | ↑ | | | △ | △ |
| | AD54 | ↓ | | | 295 | 250 |
| | AVG | | | | 295 | 250 |
| | CF28 | ↓ | | | 265 | 233 |
| | CF29 | ↓ | | | 293 | 21 |
| | CF30 | RT | | | 270 | 240 |
| | AVG | | | | 276 | 240 |
| | AD58 | 400°F | | | 219 | 190 |
| | AD59 | ↑ | | | 207 | 195 |
| | AD60 | ↓ | | | 204 | 186 |
| | AVG | | | | 210 | 190 |
| | CF31 | ↓ | | | 226 | 193 |
| | CF32 | ↓ | | | 231 | 188 |
| | CF33 | 400°F | | | 227 | 198 |
| | AVG | | 228 | 193 | | |
| AD61 | 600°F | 208 | 173 | | | |
| AD62 | ↑ | 209 | 170 | | | |
| AD63 | ↓ | 187 | 174 | | | |
| AVG | | 201 | 172 | | | |
| CF34 | ↓ | 199 | 166 | | | |
| CF35 | ↓ | 195 | 169 | | | |
| CF36 | 600°F | 218 | 170 | | | |
| AVG | | 204 | 168 | | | |

TABLE XX BEARING TEST SUMMARY (Continued)

| Alloy | Specimen ID | Test Temp. | Grain Direction | e/D | Ultimate Bearing Strength(ksi) | Bearing Yield Strength(ksi) |
|----------|-------------|------------|-----------------|-----|--------------------------------|-----------------------------|
| Ti-6-4 | AD64 | RT | T | 2.0 | 308 | 259 |
| | AD65 | | T | | 294 | 252 |
| | AD66 | | T | | 302 | 260 |
| | AVG | | | | 301 | 257 |
| | CF37 | | T | | 300 | 245 |
| | CF38 | | T | | 298 | 266 |
| | CF39 | RT | T | | 290 | 255 |
| | AVG | | | | 296 | 255 |
| | AD67 | 400°F | T | | 215 | 194 |
| | AD68 | | T | | 237 | 195 |
| | AD69 | 400°F | T | 2.0 | 223 | 193 |
| | AVG | | | | 225 | 194 |
| | AD55 | RT | L | 1.5 | 248 | 210 |
| | AD56 | | L | | 244 | 207 |
| | AD57 | | L | | 239 | 207 |
| | AVG | | | | 244 | 208 |
| | CF25 | | L | | 253 | 217 |
| | CF26 | | L | | 240 | 205 |
| | CF27 | RT | L | 1.5 | 247 | 209 |
| | AVG | | | | 247 | 210 |
| Ti-8-1-1 | FD49 | -110°F | L | 2.0 | 323 | 282 |
| | FD50 | | L | | △ | △ |
| | FD51 | -110°F | L | | △ | △ |
| | AVG | | | | 323 | 282 |
| | FD52 | RT | L | | 279 | 228 |
| | FD53 | | L | | 296 | 240 |
| Ti-8-1-1 | FD54 | RT | L | 2.0 | 300 | 252 |
| | AVG | | | | 292 | 240 |

TABLE XX BEARING TEST SUMMARY (Continued)

| Alloy | Specimen ID | Test Temp. | Grain Direction | e/D | Ultimate Bearing Strength(ksi) | Bearing Yield Strength(ksi) | |
|----------|-------------|------------|-----------------|-----|--------------------------------|-----------------------------|-----|
| Ti-8-1-1 | HF28 | RT | L | 2.0 | 262 | 224 | |
| | HF29 | ↓ | ↑ | | 283 | 220 | |
| | HF30 | RT | ↑ | | 266 | 218 | |
| | AVG | | | | 270 | 221 | |
| | FD58 | 400°F | ↑ | | 221 | 189 | |
| | FD59 | ↑ | ↑ | | 221 | 181 | |
| | FD60 | ↓ | ↑ | | 219 | 184 | |
| | AVG | | | | 220 | 185 | |
| | HF31 | ↓ | ↑ | | 214 | 169 | |
| | HF32 | ↓ | ↑ | | 219 | 171 | |
| | HF33 | 400°F | ↓ | | 212 | 176 | |
| | AVG | | | | 215 | 172 | |
| | FD61 | 600°F | ↑ | | 199 | 174 | |
| | FD62 | ↑ | ↑ | | 186 | 160 | |
| | FD63 | ↓ | ↑ | | 192 | 167 | |
| | AVG | | | | 192 | 167 | |
| | HF34 | ↓ | ↑ | | 197 | 154 | |
| | HF35 | ↓ | ↑ | | 186 | 151 | |
| | HF36 | 600°F | ↓ | | L | 192 | 150 |
| | AVG | | | | 192 | 152 | |
| | FD64 | RT | T | | 290 | 249 | |
| | FD65 | ↑ | ↑ | | 299 | 251 | |
| | FD66 | ↑ | ↑ | | 285 | 247 | |
| | AVG | | | | 291 | 249 | |
| | HF37 | ↓ | ↑ | | 310 | 269 | |
| | HF38 | ↓ | ↑ | | 314 | 255 | |
| | HF39 | RT | T | | 326 | 281 | |
| | AVG | | | | 323 | 268 | |
| Ti-8-1-1 | | | | | | | |

TABLE XX BEARING TEST SUMMARY (Continued)

| Alloy | Specimen ID | Test Temp. | Grain Direction | e/D | Ultimate Bearing Strength(ksi) | Bearing Yield Strength(ksi) |
|----------|-------------|------------|-----------------|-----|--------------------------------|-----------------------------|
| Ti-8-1-1 | FD67 | 400°F | T | 2.0 | 226 | 190 |
| | FD68 | 400°F | T | 2.0 | 220 | 190 |
| | FD69 | 400°F | T | 2.0 | 221 | 195 |
| | AVG | | | | 222 | 192 |
| | FD55 | RT | L | 1.5 | 239 | 203 |
| | FD56 | RT | L | 1.5 | 241 | 197 |
| | FD57 | RT | L | 1.5 | 237 | 203 |
| | AVG | | | | 239 | 201 |
| | HF25 | RT | L | 1.5 | 228 | 194 |
| | HF26 | RT | L | 1.5 | 225 | 189 |
| Ti-8-1-1 | HF27 | RT | L | 1.5 | 213 | 177 |
| | AVG | | | | 222 | 187 |
| Ti-6-6-2 | LD49 | -110°F | L | 2.0 | 344 | 323 |
| | LD50 | -110°F | L | 2.0 | 370 | 335 |
| | LD51 | -110°F | L | 2.0 | △ | △ |
| | AVG | | | | 357 | 329 |
| | LD52 | RT | L | 2.0 | 309 | 274 |
| | LD53 | RT | L | 2.0 | 340 | 288 |
| | LD54 | RT | L | 2.0 | 300 | 275 |
| | AVG | | | | 316 | 279 |
| | NF28 | RT | L | 2.0 | 297 | 260 |
| | NF29 | RT | L | 2.0 | 308 | 256 |
| | NF30 | RT | L | 2.0 | 287 | 246 |
| | AVG | | | | 297 | 254 |
| | LD58 | 400°F | L | 2.0 | 254 | 219 |
| | LD59 | 400°F | L | 2.0 | 260 | 228 |
| Ti-6-6-2 | LD60 | 400°F | L | 2.0 | 251 | 224 |
| | AVG | | | | 255 | 224 |

TABLE XX BEARING TEST SUMMARY (Continued)

| Alloy | Specimen ID | Test Temp. | Grain Direction | e/D | Ultimate Bearing Strength(ksi) | Bearing Yield Strength(ksi) |
|----------|-------------|------------|-----------------|-----|--------------------------------|-----------------------------|
| Ti-6-6-2 | NF31 | 400°F | L | 2.0 | 254 | 219 |
| | NF32 | ↓ | ↑ | | 244 | 216 |
| | NF33 | 400°F | ↓ | | 253 | 219 |
| | AVG | | | | 250 | 218 |
| | LD61 | 600°F | ↓ | | 225 | 208 |
| | LD62 | ↑ | ↓ | | 214 | 207 |
| | LD63 | ↓ | ↓ | | 209 | 201 |
| | AVG | | | | 216 | 205 |
| | NF34 | ↓ | ↓ | | 245 | 204 |
| | NF35 | ↓ | ↓ | | 229 | 201 |
| | NF36 | 600°F | L | | 234 | 199 |
| | AVG | | | | 236 | 201 |
| | LD64 | RT | T | | 344 | 298 |
| | LD65 | ↑ | ↑ | | 340 | 291 |
| | LD66 | ↓ | ↓ | | 339 | 282 |
| | AVG | | | | 341 | 290 |
| | NF37 | ↓ | ↓ | | 310 | 269 |
| | NF38 | ↓ | ↓ | | 314 | 255 |
| | NF39 | RT | ↓ | | 326 | 284 |
| | AVG | | | | 317 | 270 |
| | LD67 | 400°F | ↓ | | 244 | 207 |
| | LD68 | ↑ | ↓ | | 254 | 227 |
| | LD69 | 400°F | T | | 247 | 231 |
| | AVG | | | | 248 | 222 |
| | LD55 | RT | L | | 262 | 228 |
| | LD56 | ↑ | ↓ | | 270 | 235 |
| | LD57 | ↓ | ↓ | | 274 | - |
| AVG | RT | L | 269 | 231 | | |

TABLE XX BEARING TEST SUMMARY (Concluded)

| Alloy | Specimen ID | Test Temp. | Grain Direction | e/D | Ultimate Bearing Strength(ksi) | Bearing Yield Strength(ksi) |
|--|-------------|------------|-----------------|-----|--------------------------------|-----------------------------|
| Ti-6-6-2 | NF25 | RT | L | 1.5 | 247 | 218 |
| ↑ | NF26 | ↓ | ↓ | ↓ | 258 | 223 |
| Ti-6-6-2 | NF27 | RT | L | 1.5 | 250 | 228 |
| | AVG | | | | 252 | 223 |
| <p>A Abnormal deformation at loading hole</p> | | | | | | |

TABLE XXI SHEAR TEST SUMMARY

| Alloy | Specimen ID | Test Temp | Grain Direction | Double Shear Strength (ksi) |
|--------|-------------|-----------|-----------------|-----------------------------|
| Ti-6-4 | AD70 | -110°F | L | 103 |
| | AD71 | | | 108 |
| | AD72 | | | 107 |
| | Avg | | | 106 |
| | AD73 | RT | | 95 |
| | AD74 | | | 94 |
| | AD75 | | | 92 |
| | AD76 | | | 93 |
| | AD77 | | | 90 |
| | AD78 | | | 89 |
| | Avg | | | 92 |
| | CF58 | | | 94 |
| | CF59 | | | 91 |
| | CF60 | | | 93 |
| | CF61 | | | 89 |
| | CF62 | | | 90 |
| | CF63 | 91 | | |
| | Avg | 91 | | |
| | AD79 | 400°F | | 79 |
| | AD80 | | | 75 |
| | AD81 | | | |
| | Avg | | | 77 |
| | CF64 | | | △ |
| | CF65 | | | 77 |
| | CF66 | △ | | |
| | Avg | 77 | | |
| | AD82 | 600°F | | 70 |
| | AD83 | | | 70 |
| AD84 | 71 | | | |
| Avg | 70 | | | |
| Ti-6-4 | | | | |

TABLE XXI SHEAR TEST SUMMARY (Continued)

| Alloy | Specimen ID | Test Temp | Grain Direction | Double Shear Strength (ksi) | |
|----------|-------------|-----------|-----------------|-----------------------------|----|
| Ti-6-4 | CF67 | 600°F | L | 69 | |
| | CF68 | ↕ | ↕ | 69 | |
| | CF69 | 600°F | L | 72 | |
| | Avg | | | 70 | |
| | AD85 | RT | T | 88 | |
| | AD86 | ↕ | ↕ | 94 | |
| | AD87 | ↕ | ↕ | 95 | |
| | Avg | | | 92 | |
| | CF70 | ↕ | ↕ | 90 | |
| | CF71 | ↕ | ↕ | 92 | |
| | CF72 | RT | ↕ | 94 | |
| | Avg | | | 92 | |
| | CF73 | 400°F | ↕ | 78 | |
| | CF74 | ↕ | ↕ | 77 | |
| Ti-6-4 | CF75 | ↕ | T | 74 | |
| | Avg | | | 76 | |
| Ti-8-1-1 | FD70 | -110°F | L | 102 | |
| | FD71 | ↕ | ↕ | △ | |
| | FD72 | ↕ | ↕ | 103 | |
| | Avg | | | 102 | |
| | FD73 | RT | ↕ | 90 | |
| | FD74 | ↕ | ↕ | 92 | |
| | FD75 | ↕ | ↕ | 93 | |
| | FD76 | ↕ | ↕ | 92 | |
| | FD77 | ↕ | ↕ | 89 | |
| | FD78 | ↕ | ↕ | 90 | |
| | Avg | | | 91 | |
| | HF58 | ↕ | ↕ | 89 | |
| | Ti-8-1-1 | HF59 | RT | L | 87 |

TABLE XXI SHEAR TEST SUMMARY (Continued)

| Alloy | Specimen ID | Test Temp | Grain Direction | Double Shear Strength (ksi) |
|----------|-------------|-----------|-----------------|-----------------------------|
| Ti-8-1-1 | HF60 | RT | L | 88 |
| | HF61 | | | 90 |
| | HF62 | RT | L | 86 |
| | HF63 | | | 86 |
| | Avg | | | 87 |
| | FD79 | 400°F | L | 78 |
| | FD80 | | | 79 |
| | FD81 | 400°F | L | 79 |
| | Avg | | | 79 |
| | HF64 | | | △ |
| | HF65 | 400°F | L | △ |
| | HF66 | | | △ |
| | Avg | 600°F | L | |
| | FD82 | | | 70 |
| | FD83 | | | 69 |
| | FD84 | 600°F | L | 68 |
| | Avg | | | 69 |
| | HF67 | | | 66 |
| | HF68 | 600°F | L | 68 |
| | HF69 | | | 70 |
| | Avg | RT | T | 68 |
| | FD85 | | | 87 |
| | FD86 | | | 88 |
| | FD87 | RT | T | 87 |
| Avg | 87 | | | |
| | HF70 | RT | T | 90 |
| | HF71 | | | 88 |
| Ti-8-1-1 | HF72 | | | 86 |
| | Avg | 88 | | |

TABLE XXI SHEAR TEST SUMMARY (Continued)

| Alloy | Specimen ID | Test Temp | Grain Direction | Double Shear Strength (ksi) |
|----------|-------------|-----------|-----------------|-----------------------------|
| Ti-8-1-1 | HF73 | 400°F | T | △ |
| | HF74 | 400°F | | △ |
| Ti-8-1-1 | HF75 | 400°F | T | 75 |
| | Avg | | | 75 |
| Ti-6-6-2 | LD70 | -110°F | L | 118 |
| | LD71 | -110°F | | 121 |
| | LD72 | -110°F | | 119 |
| | Avg | -110°F | | 119 |
| | LD73 | RT | | 102 |
| | LD74 | RT | | 100 |
| | LD75 | RT | | 101 |
| | LD76 | RT | | 102 |
| | LD77 | RT | | 99 |
| | LD78 | RT | | 100 |
| | Avg | RT | | 101 |
| | NF58 | RT | | 100 |
| | NF59 | RT | | 100 |
| | NF60 | RT | | 101 |
| | NF61 | RT | | 104 |
| | HF62 | RT | | 101 |
| | NF63 | RT | | 99 |
| | Avg | RT | | 101 |
| | LD79 | 400°F | | 92 |
| | LD80 | 400°F | | 90 |
| LD81 | 400°F | 89 | | |
| Avg | 400°F | 90 | | |
| Ti-6-6-2 | NF64 | 400°F | L | △ |
| | NF65 | | | △ |

TABLE XXI SHEAR TEST SUMMARY (Concluded)

| Alloy | Specimen ID | Test Temp | Grain Direction | Double Shear Strength (ksi) | | |
|----------|-------------|-----------|-----------------|-----------------------------|---|-----|
| Ti-6-6-2 | NF66 | 400°F | L | △ | | |
| | Avg | | | | | |
| | LD82 | 600°F | L | 82 | | |
| | LD83 | | | 80 | | |
| | LD84 | | | 82 | | |
| | Avg | | | 81 | | |
| | NF67 | | | 83 | | |
| | NF68 | 600°F | L | 83 | | |
| | NF69 | | | 84 | | |
| | Avg | | | 83 | | |
| | LD85 | | | RT | T | 103 |
| | LD86 | | | | | 101 |
| | LD87 | 102 | | | | |
| | Avg | 102 | | | | |
| | NF70 | 100 | | | | |
| | NF71 | RT | T | 99 | | |
| | NF72 | | | 101 | | |
| | Avg | | | 100 | | |
| | NF73 | | | 400°F | T | 86 |
| | NF74 | | | | | △ |
| NF75 | 90 | | | | | |
| Avg | 88 | | | | | |

△ Abnormal failure with bending

TABLE XXII CHARPY IMPACT TEST SUMMARY

| Alloy | Spec. Ident. | Grain Direction | Test Temperature (°F) | Impact Strength (ft-lb) | |
|--------|--------------|-------------------------|-----------------------|-------------------------|---------------|
| | | | | .250 Width | .394 Width |
| T1-6-4 | AL1 | Longitudinal | -110 | 7.0 | |
| | AL2 | | 7.0 | | |
| | AL3 | | 7.0 | | |
| | CL1 | | 6.0 | | |
| | CL2 | | 6.5 | | |
| | CL3 | | 6.0 | | |
| | AE48 | | 5.5 | | |
| | AE49 | | 5.5 | | |
| | AE50 | | 6.5 | | |
| | CF52 | | 5 | | |
| | CF53 | | 6 | | |
| | CF54 | | 6 | | |
| | EM28 | | | | |
| | EM29 | | | | |
| | EM30 | | | | |
| | AE45 | | 6.0 | | |
| | AE46 | | 6.0 | | |
| | AE47 | | 7.0 | | |
| | CF49 | | 7.0 | | |
| | CF50 | | 6.4 | | |
| | CF51 | | 6.0 | | |
| | AE51 | | 11.0 | | |
| | AE52 | | 11.0 | | |
| | AE53 | | 11.0 | | |
| | CF55 | | 10.5 | | |
| | CF56 | | 9.0 | | |
| | CF57 | | 9.5 | | |
| | CT1 | 9.0 | | | |
| | CT2 | 6.5 | | | |
| | CT3 | 9.5 | | | |
| | CF43 | 14 | | | |
| | CF44 | 11 | | | |
| | CF45 | 13 | | | |
| EM25 | | | | | |
| EM26 | | | | | |
| EM27 | | | | | |
| CF40 | 12.0 | | | | |
| CF41 | 15.0 | | | | |
| CF42 | 14.5 | | | | |
| CF46 | 17.0 | | | | |
| CF47 | 16.5 | | | | |
| CF48 | 16.5 | | | | |
| | | Longitudinal Transverse | | | 9 8 8 |
| T1-6-4 | | Transverse | | | 9 28 28 |

TABLE XXII CHARPY IMPACT TEST SUMMARY (Continued)

| Alloy | Spec. Ident. | Grain Direction | Test Temperature (°F) | Impact Strength (ft-lb) | |
|----------|--------------|-----------------|-----------------------|-------------------------|------------|
| | | | | .250 Width | .394 Width |
| Ti-8-1-1 | FL1 | Longitudinal | -110 | 10.0 | |
| | FL2 | | 10.0 | | |
| | FL3 | | 10.5 | | |
| | HL1 | | 10.5 | | |
| | HL2 | | 10.5 | | |
| | HL3 | | 10.0 | | |
| | FE48 | | 6 | | |
| | FE49 | | 11 | | |
| | FE50 | | 10.5 | | |
| | HF52 | | 8 | | |
| | HF53 | | 11 | | |
| | HF54 | | 10 | | |
| | KM28 | | | 18.5 | |
| | KM29 | | | 20 | |
| | KM30 | | | 18 | |
| | FE45 | | 72 | | |
| | FE46 | | 110 | 11.5 | |
| | FE47 | | | 12.0 | |
| | HF49 | | | 12.5 | |
| | HF50 | | | 11.0 | |
| | HF51 | | 110 | 12.5 | |
| | FE51 | | 400 | 12.9 | |
| | FE52 | | | 21.5 | |
| | FE53 | | | 21.5 | |
| | HF55 | | | 22.0 | |
| | HF56 | | | 18.0 | |
| | HF57 | | | 17.5 | |
| | HT1 | | 400 | 19.0 | |
| | HT2 | | 110 | 14.0 | |
| | HT3 | | | 15.0 | |
| | HF43 | 110 | 15.0 | | |
| | HF44 | 72 | 9.5 | | |
| | HF45 | | 20.5 | | |
| KM25 | | 18 | | | |
| KM26 | | | 19 | | |
| KM27 | | | 17.5 | | |
| HF40 | -72 | | 19.5 | | |
| HF41 | 110 | 21.5 | | | |
| HF42 | | 23.5 | | | |
| HF46 | 110 | 21 | | | |
| HF47 | 400 | 24.5 | | | |
| HF48 | 400 | 24.5 | | | |
| Ti-8-1-1 | | Transverse | 400 | 22.5 | |

TABLE XXII CHARPY IMPACT TEST SUMMARY (Concluded)

| Alloy | Spec. Ident. | Grain Direction | Test Temperature (°F) | Impact Strength (ft-lb) | | |
|----------|--------------|-----------------|----------------------------|-------------------------|------------|-----|
| | | | | .250 Width | .394 Width | |
| Ti-6-6-2 | LL1 | Longitudinal | -110 Δ | 6.5 | | |
| | LL2 | | | 6.0 | | |
| | LL3 | | | 6.5 | | |
| | NL1 | | | 7.0 | | |
| | NL2 | | | 5.0 | | |
| | NL3 | | | 6.0 | | |
| | LE48 | | | 11 | | |
| | LE49 | | | 6 | | |
| | LE50 | | | 5 | | |
| | NF52 | | | 5 | | |
| | NF53 | | | 5 | | |
| | NF54 | | | 4 | | |
| | RM28 | | | | | 5.5 |
| | RM29 | | | | | 4.5 |
| | RM30 | | | 72 | | 5.5 |
| | LE45 | | | 110 | 9.5 | |
| | LE46 | | | | 9.0 | |
| | LE47 | | | | 10.0 | |
| | NF49 | | | | 4.5 | |
| | NF50 | | | | 6.0 | |
| | NF51 | | | 110 | 5.5 | |
| | LE51 | | | 400 | 21.5 | |
| | LE52 | | | | 21.5 | |
| | LE53 | | | | 22.0 | |
| | NF55 | | | | 8.0 | |
| | NF56 | | | | 8.5 | |
| | NF57 | | Longitudinal Transverse | 400 | 9.5 | |
| | NT1 | -110 Δ | | 10.0 | | |
| | NT2 | | | 10.0 | | |
| | NT3 | -110 Δ | | 12.5 | | |
| | NF43 | 72 Δ | | 12 | | |
| | NF44 | | | 13.5 | | |
| | NF45 | | | 13.0 | | |
| RM25 | | | | | 5 | |
| RM26 | | | | | 5 | |
| RM27 | | 72 | | | 5 | |
| NF40 | | 110 | 12 | | | |
| NF41 | | | 15.5 | | | |
| NF42 | | 110 | 12.0 | | | |
| NF46 | | 400 | 19.0 | | | |
| NF47 | | | 16.0 | | | |
| Ti-6-6-2 | NF48 | Transverse | 400 | 16.5 | | |

Δ Specimens for testing at -110°F were fabricated and tested separately from other specimens.

TABLE XXIII FRACTURE TOUGHNESS TEST SUMMARY
(Longitudinal)

| Alloy | Spec. Ident. | Test Temp | K_{Ic} (ksi \sqrt{in}) | |
|----------|--------------|-----------|--------------------------------|----|
| Ti-6-4 | AE25 | -110F | 87 | |
| | AE26 | | 86 | |
| | AE27 | | 67 | |
| | AE28 | | 71 | |
| | AE29 | | 67 | |
| | AVG | | | |
| | CG26 | | 64 | |
| | CG27 | | 66 | |
| | CG28 | | 65 | |
| | CG29 | | 62 | |
| | CG30 | | 61 | |
| | AVG | | 64 | |
| | AE30 | | RT | 74 |
| | AE31 | | RT | 72 |
| | AE32 | | RT | 74 |
| | AE33 | | RT | -- |
| | AE34 | | RT | 73 |
| | AVG | | RT | 73 |
| CG31 | RT | 70 | | |
| CG32 | RT | 61 | | |
| CG33 | RT | 61 | | |
| CG34 | RT | 71 | | |
| CG35 | RT | 66 | | |
| AVG | RT | 65 | | |
| EM16 | RT | 77 | | |
| EM17 | RT | 81 | | |
| EM18 | RT | 79 | | |
| AVG | RT | 79 | | |
| Ti-6-4 | | | | |
| Ti-8-1-1 | | | | |
| Ti-8-1-1 | FE25 | -110F | 77 | |
| | FE26 | | 76 | |
| | FE27 | | 75 | |
| | FE28 | | 79 | |
| | FE29 | | 74 | |
| | AVG | | 76 | |
| | HG26 | | 89 | |
| | HG27 | | 92 | |
| | HG28 | | 87 | |
| | HG29 | | 85 | |
| | HG30 | | 91 | |
| | AVG | | 89 | |
| | FE30 | | RT | 79 |
| | FE31 | | RT | 84 |

TABLE XXIII FRACTURE TOUGHNESS TEST SUMMARY (Continued)
(Longitudinal)

| Alloy | Spec. Ident. | Test Temp | K_{Ic} (ksi \sqrt{in}) |
|----------|--------------|-----------|--------------------------------|
| Ti-8-1-1 | FE32 | RT | 81 |
| | FE33 | | 84 |
| | FE34 | | 85 |
| | AVG | | 83 |
| | HG31 | | 86 |
| | HG32 | | 90 |
| | HG33 | | 85 |
| | HG34 | | 89 |
| | HG35 | | 90 |
| | AVG | | 88 |
| | KM16 | | 84 |
| | KM17 | | 91 |
| | KM18 | | 80 |
| | AVG | | 85 |
| Ti-8-1-1 | | RT | |
| Ti-6-6-2 | LE25 | -110F | 43 |
| | LE26 | | 47 |
| | LE27 | | 44 |
| | LE28 | | 49 |
| | LE29 | | 48 |
| | AVG | | 46 |
| | NG26 | | 51 |
| | NG27 | | 59 |
| | NG28 | | 60 |
| | NG29 | | 61 |
| | NG30 | | 59 |
| | AVG | | 58 |
| | LE30 | -110F | 57 |
| | LE31 | RT | 61 |
| | LE32 | | 52 |
| | LE33 | | 59 |
| | LE34 | | 60 |
| | AVG | | 58 |
| | NG31 | | 76 |
| | NG32 | | 74 |
| | NG33 | | 74 |
| | NG34 | | 71 |
| | NG35 | | 68 |
| | AVG | | 71 |
| | RM16 | | 51 |
| | RM17 | | 51 |
| | RM18 | | 51 |
| | AVG | | 58 |
| Ti-6-6-2 | | RT | |

TABLE XXIV DELAYED FAILURE TEST SUMMARY
(Room Temperature, Longitudinal)

| Alloy | Spec. Ident. | K_{Ti} (ksi \sqrt{in}) | Time (Min) | Notes |
|----------|--------------|--------------------------------|---------------|------------|
| Ti-6-4 | AE35 | 55 | 1 | Fail |
| | AE36 | 40 | 3 | Fail |
| | AE37 | 23 | 180 | No Failure |
| | AE38 | 31 | 120 | No Failure |
| | AE39 | 42 | 180 | No Failure |
| | AE40 | 40 | 180 | No Failure |
| | AE41 | 36 | 6000 | No Failure |
| | AE42 | 43 | 6 | Fail |
| | AE43 | 38 | 60 | No Failure |
| | AE44 | 45 | 3 | Fail |
| Ti-6-4 | CG36 | 43 | 180 | No Failure |
| | CG37 | 51 | 3 | Fail |
| | CG38 | 48 | 2 | Fail |
| | CG39 | 45 | 6780 | No Failure |
| | CG40 | 52 | 3 | Fail |
| | CG41 | 51 | 3 | Fail |
| | CG42 | 42 | 3 | Fail |
| | CG43 | 42 | 74 | No Failure |
| | CG44 | 39 | 78 | No Failure |
| | CG45 | 53 | 1 | Fail |
| Ti-6-4 | EM19 | 29 | 187 | No Failure |
| | EM20 | 39 | 1083 | No Failure |
| | EM21 | 47 | 5 | Fail |
| | EM22 | 42 | 10 | Fail |
| | EM23 | 42 | 6015 | No Failure |
| | EM24 | 43 | 90 | No Failure |
| Ti-8-1-1 | FE35 | 40 | 3 | Fail |
| | FE36 | 25 | 180 | No Failure |
| | FE37 | 36 | 180 | No Failure |
| | FE38 | 43 | 78 | Fail |
| | FE39 | 35 | 4 | Fail |
| | FE40 | 37 | 180 | No Failure |
| | FE41 | 34 | 7020 | No Failure |
| | FE42 | 43 | 6 | Fail |
| | FE43 | 40 | 6 | Fail |
| | FE44 | 37 | 4 | Fail |
| Ti-8-1-1 | HG36 | 34 | 180 | No Failure |
| | HG37 | 56 | 4 | Fail |
| | HG38 | 40 | 9 | Fail |

TABLE XXIV DELAYED FAILURE TEST SUMMARY (Continued)
 (Room Temperature, Longitudinal)

| Alloy | Spec. Ident. | K_{Ti} (ksi \sqrt{in}) | Time (Min) | Notes |
|----------|--------------|--------------------------------|---------------|------------|
| Ti-8-1-1 | HG39 | 38 | 35 | Fail |
| | HG40 | 36 | 2700 | Fail |
| | HG41 | 33 | 6840 | No Failure |
| | HG42 | 47 | 9 | Fail |
| | HG43 | 50 | 9 | Fail |
| | HG44 | 40 | 80 | No Failure |
| | HG45 | 41 | 10 | Fail |
| | KM19 | 34 | 181 | No Failure |
| | KM20 | 36 | 17 | Fail |
| | KM21 | 39 | 6 | Fail |
| | KM22 | 32 | 6009 | No Failure |
| | KM23 | 40 | 85 | No Failure |
| | KM24 | 43 | 5 | Fail |
| | Ti-6-6-2 | LE35 | 51 | 1 |
| LE36 | | 43 | 1 | Fail |
| LE37 | | 29 | 180 | No Failure |
| LE38 | | 34 | 1 | Fail |
| LE39 | | 36 | 1 | Fail |
| LE40 | | 41 | 5880 | No Failure |
| LE41 | | 34 | 240 | No Failure |
| LE42 | | 37 | 1 | Fail |
| LE43 | | 38 | 60 | No Failure |
| LE44 | | 39 | 60 | No Failure |
| NG36 | | 37 | 180 | No Failure |
| NG37 | | 46 | 180 | No Failure |
| NG38 | | 57 | 2 | Fail |
| NG39 | | 52 | 2 | Fail |
| NG40 | 42 | 5640 | No Failure | |
| NG41 | 46 | 60 | No Failure | |
| NG42 | 53 | 2 | Fail | |
| NG43 | 51 | 65 | No Failure | |
| NG44 | 58 | 2 | Fail | |
| NG45 | 63 | 1 | Fail | |
| Ti-6-6-2 | RM19 | 27 | 185 | No Failure |
| | RM20 | 36 | 1055 | No Failure |
| | RM21 | 51 | 2 | Fail |
| | RM22 | 48 | 2 | Fail |
| | RM23 | 36 | 6003 | No Failure |
| | RM24 | 41 | 3 | Fail |

TABLE XXV CREEP TEST SUMMARY

| Alloy | Specimen ID | Stress (ksi) | Test Temp | Creep Strain (in/in) | Time (Hr) | Remarks | | |
|----------------------------------|-------------|--------------|-----------|----------------------|-----------|-------------------|----------|----------|
| Ti-6-4 (TUS 110 TYS 89) | AE-4 | 109 | 400F | - | .15 | Failed | | |
| | AE-6 | 108 | ↑ | 0 | 0 | | Unloaded | |
| | | | | .0038 | 1 | | | |
| | | | | .0052 | 2 | | | |
| | | | | .0057 | 3 | | | |
| | | | | .0066 | 68 | | | |
| | .0067 | 120 | | | | | | |
| | AE-5 | 107 | | 0 | 0 | | Unloaded | |
| | | | | .0028 | 1 | | | |
| | | | | .0039 | 2 | | | |
| | | | | .0046 | 3 | | | |
| | | | | .0050 | 4 | | | |
| | .0054 | 17 | | | | | | |
| | .0060 | 89 | | | | | | |
| | .0060 | 115 | | | | | | |
| AE-1 | 105 | 0 | | 0 | | Unloaded | | |
| | | .0001 | 1 | | | | | |
| | | .0008 | 20 | | | | | |
| | | .0010 | 117 | | | | | |
| | | .0012 | 261 | | | | | |
| | | .0012 | 525 | | | | | |
| | | .0014 | 597 | | | | | |
| | | .0014 | 964 | | | | | |
| Ti-8-1-1 (TUS 115 TYS 89) | FE-2 | 114 | ↓ | - | .05 | Failed | | |
| | FE-6 | 114 | | - | 0 | Failed on Loading | | |
| | | | | FE-4 | 113 | 0 | 0 | Unloaded |
| | | | | | | .0038 | 1 | |
| | | | | | | .0048 | 2 | |
| | | | | | | .0057 | 18 | |
| | .0060 | 90 | | | | | | |
| | .0062 | 162 | | | | | | |
| | .0062 | 192 | | | | | | |
| | FE-3 | 112 | | 0 | 0 | | Unloaded | |
| 0 | | | 257 | | | | | |
| .0002 | | | 353 | | | | | |
| | | | 400F | .0002 | 426 | | | |

TABLE XXV CREEP TEST SUMMARY (Continued)

| Alloy | Specimen ID | Stress (ksi) | Test Temp | Creep Strain (in/in) | Time (Hr) | Remarks | |
|--------------------------------------|-------------|--------------|-----------------|----------------------|-----------|-------------------|--|
| Ti-8-1-1 | FE-1 | 109 | 400F | 0 | 0 | | |
| | | | | .0001 | 1 | | |
| | | | | .0006 | 20 | | |
| | | | | .0008 | 260 | | |
| | | | | .0008 | 525 | | |
| | | | | .0011 | 597 | | |
| | | | | .0011 | 988 | | |
| Ti-6-6-2 (TUS 125 TYS 100) | IE-6 | 130 | 400F | - | 0 | Failed on Loading | |
| | IE-5 | 128 | no measurements | | 116 | Unloaded | |
| | IE-4 | 126 | no measurements | | 336 | Unloaded | |
| | IE-3 | 124 | | | 0 | 0 | |
| | | | | | .0230 | 1 | |
| | | | | | .0373 | 19 | |
| | | | | | .0382 | 187 | |
| | | | | | .0383 | 595 | |
| | | | | | .0391 | 691 | |
| | | | | | .0396 | 859 | |
| | IE-2 | 121 | | | 0 | 0 | |
| | | | | | .0013 | 1 | |
| | | | | | .0016 | 3 | |
| | | | | | .0016 | 5 | |
| | | | | | .0020 | 71 | |
| .0021 | | | | | 96 | | |
| .0023 | | | | | 167 | | |
| IE-1 | 119 | | 400F | 0 | 0 | | |
| | | | | .0011 | 1 | | |
| | | | | .0014 | 2 | | |
| | | | | .0017 | 4 | | |
| | | | | .0019 | 20 | | |
| | | | | .0019 | 92 | | |
| | | | | .0020 | 116 | | |
| .002 | 188 | | | | | | |
| | .002 | 428 | | | | | |
| | .0024 | 596 | | | | | |

TABLE XXV CREEP TEST SUMMARY (Continued)

| Alloy | Specimen ID | Stress (ksi) | Test Temp | Creep Strain (in/in) | Time (Hr) | Remarks |
|----------------------|-------------|--------------|-----------|----------------------|------------|-------------------|
| Ti-6-6-2 | LE-1 | | 400F | .0025 .0025 | 860 940 | Unloaded |
| Ti-6-4 | AE-15 | 100 | 600F | - | 0 | Failed on Loading |
| (TUS 101 TYS 77) | AE-19 | 100.0 | ↑ 600F | 0 | 0 | |
| | | | | .0003 | 1 | |
| | | | | .0006 | 2 | |
| | | | | .0008 | 3 | |
| | | | | .0008 | 4 | |
| | | | | .0009 | 5 | |
| | | | | .0014 | 21 | |
| | .0026 | 93 | | | | |
| | .0039 | 261 | | | | |
| | .0044 | 333 | | | | |
| | AE-17 | 99 | | 0 | 0 | |
| | | | | .0006 | 1 | |
| | | | | .0007 | 4 | |
| | | | | .0009 | 5 | |
| | | | | .0013 | 23 | |
| AE-13 | 98 | .0020 | 71 | | | |
| | | .0025 | 147 | | | |
| | | 0 | 0 | | | |
| | | .0006 | 19 | | | |
| | | .0008 | 139 | | | |
| | | .0015 | 235 | | | |
| | | .0018 | 307 | | | |
| | | .0021 | 403 | | | |
| AE-16 | 95 | .0021 | 643 | | | |
| | | .0024 | 739 | | | |
| | | .0025 | 810 | | | |
| | | .0025 | 978 | | | |
| | | 0 | 0 | | | |
| | | .0004 | 1 | | | |
| | | .0006 | 5 | | | |
| .0008 | 24 | | | | | |
| .0011 | 96 | | | | | |
| .0013 | 192 | | | | | |
| .0021 | 264 | | | | | |
| | | | 600F | | | Unloaded |
| | | | | | | Unloaded |

TABLE XXV CREEP TEST SUMMARY (Continued)

| Alloy | Specimen ID | Stress (ksi) | Test Temp | Creep Strain (in/in) | Time (Hr) | Remarks |
|----------|----------------------|--------------|-----------|----------------------|-----------|-------------------|
| Ti-6-4 | AE-16 | 95 | ↓ 600F | .0022 | 672 | Unloaded |
| | | | | .0023 | 768 | |
| | | | | .0023 | 941 | |
| | AE-13 | 93 | | 0 | 0 | |
| | | | | .0003 | 1 | |
| | | | | .0004 | 3 | |
| | | | | .0008 | 4 | |
| | | | | .0010 | 5 | |
| | | | | .0021 | 22 | |
| | | | | .0027 | 46 | |
| | | | | .0034 | 118 | |
| | | | | .0044 | 214 | |
| | | | | .0048 | 382 | |
| | AE-14 | 89.0 | | .0048 | 522 | |
| | | | | .0050 | 718 | |
| | | | | .0051 | 957 | |
| | | | | 0 | 0 | |
| | | | | .0006 | 1 | |
| .0006 | | | 2 | | | |
| .0009 | | | 90 | | | |
| AE-18 | 79.0 | .0010 | 498 | | | |
| | | .0010 | 1097 | | | |
| | | .00105 | 1169 | | | |
| | | 0 | 0 | | | |
| | | .0006 | 1 | | | |
| | | .0006 | 2 | | | |
| Ti-8-1-1 | (TUS 107 TYS 81) | 107 | 600F | - | 0 | Failed on Loading |
| | | | | - | 0 | Failed on Loading |
| | | | | 0 | 0 | Unloaded |
| .0002 | 1 | | | | | |
| FE-18 | 106 | - | 0 | Failed on Loading | | |
| FE-13 | 105 | - | 0 | 0 | Unloaded | |
| | | | .0002 | 141 | | |

TABLE XXV CREEP TEST SUMMARY (Continued)

| Alloy | Specimen ID | Stress (ksi) | Test Temp | Creep Strain (in/in) | Time (Hr) | Remarks | |
|----------|-------------|--------------|-----------|----------------------|-----------|---------|-------------------|
| Ti-8-1-1 | FE-14 | 105.0 | 600F | 0 | 0 | | |
| | | | ↑ | .0004 | 1 | | |
| | | | ↕ | .0006 | 2 | | |
| | | | ↕ | .0009 | 20 | | |
| | | | ↕ | .0018 | 235 | | |
| | | | ↕ | .0021 | 475 | | |
| | 600F | .0024 | 643 | | | | |
| | FE-23 | 104 | - | - | 0 | | Failed on Loading |
| | FE-21 | 102.0 | 600F | ↑ | 0 | | 0 |
| | | | | ↑ | .0002 | | 1 |
| | | | | ↑ | .0003 | | 2 |
| | | | | ↑ | .0004 | | 3 |
| | | | | ↑ | .0007 | | 19 |
| | | | | ↑ | .0010 | | 91 |
| FE-24 | 100.0 | 600F | ↑ | .0013 | 258 | | |
| | | | ↑ | .0017 | 426 | | |
| | | | ↑ | 0 | 0 | | |
| | | | ↑ | .0003 | 1 | | |
| | | | ↑ | .0003 | 3 | | |
| | | | ↑ | .0008 | 22 | | |
| FE-17 | 95.0 | 600F | ↑ | .0009 | 70 | | |
| | | | ↑ | .0010 | 237 | | |
| | | | ↑ | .0012 | 405 | | |
| | | | ↑ | .0014 | 477 | | |
| | | | ↑ | 0 | 0 | | |
| | | | ↑ | .0001 | 1 | | |
| FE-15 | 81.0 | 600F | ↑ | .0001 | 2 | | |
| | | | ↑ | .0004 | 16 | | |
| | | | ↑ | .0006 | 65 | | |
| | | | ↑ | .0007 | 232 | | |
| | | | ↑ | .0007 | 472 | | |
| | | | ↑ | 0 | 0 | | |
| ↑ | .0004 | 1 | | | | | |
| ↑ | .0005 | 2 | | | | | |
| ↑ | .0005 | 20 | | | | | |
| ↑ | .0006 | 260 | | | | | |
| ↑ | .0006 | 500 | | | | | |

TABLE XXV CREEP TEST SUMMARY (Continued)

| Alloy | Specimen ID | Stress (ksi) | Test Temp | Creep Strain (in/in) | Time (Hr) | Remarks |
|---------------------------------|-------------|--------------|-----------|----------------------|-----------|-------------------|
| Ti-6-6-2 (TUS 121 TYS 97) | LE-14 | 127 | 600F | - | 0 | Failed on Loading |
| | LE-15 | 123 | | - | 0 | Failed on Loading |
| | LE-21 | 121 | | - | 0 | Failed on Loading |
| | LE-13 | 120 | | 0 | 0 | |
| | | | | .0018 | 1 | |
| | | | | .0027 | 2 | |
| | | | | .0033 | 3 | |
| | | | | .0037 | 4 | |
| | | | | .0086 | 20 | |
| | | | | .0120 | 44 | |
| | | | | .0200 | 140 | |
| | | | | .0223 | 188 | |
| | | | | .0245 | 236 | |
| | .0273 | 303 | | | | |
| | .0349 | 404 | | | | |
| | .0372 | 476 | | | | |
| | .0390 | 572 | | | | |
| | .0407 | 644 | | | | |
| | .0434 | 740 | | | | |
| | .0444 | 812 | | | | |
| | .0457 | 908 | | | | |
| .0471 | 985 | Unloaded | | | | |
| LE-16 | 117 | | 600F | 0 | 0 | |
| | | | | .0009 | 1 | |
| | | | | .0012 | 2 | |
| | | | | .0016 | 4 | |
| | | | | .0066 | 93 | |
| | | | | .0072 | 140 | |
| | | | | .0081 | 189 | |
| | | | | .0090 | 261 | |
| | | | | .0104 | 357 | |
| | | | | .0114 | 525 | |
| | | | | .0120 | 597 | |
| | | | | .0123 | 765 | |
| | | | | .0129 | 861 | |
| | | | | .0134 | 937 | Unloaded |

TABLE XXV CREEP TEST SUMMARY (Continued)

| Alloy | Specimen ID | Stress (ksi) | Test Temp | Creep Strain (in/in) | Time (Hr) | Remarks |
|------------------------------|-------------|--------------|-----------|----------------------|-----------|---------|
| Ti-6-6-2 | LE-18 | 114.0 | 600F | 0 | 0 | |
| | | | | .0009 | 1 | |
| | | | | .0012 | 2 | |
| | | | | .0014 | 3 | |
| | | | | .0015 | 5 | |
| | | | | .0028 | 41 | |
| | | | | .0040 | 112 | |
| | | | | .0052 | 376 | |
| | .0060 | 616 | | | | |
| | LE-17 | 112 | 600F | 0 | 0 | |
| | | | | .0006 | 1 | |
| | | | | .0008 | 3 | |
| | | | | .0009 | 5 | |
| | | | | .0015 | 24 | |
| | | | | .0024 | 71 | |
| | | | | .0033 | 142 | |
| | | | | .0042 | 310 | |
| | LE-20 | 100.0 | 600F | 0 | 0 | |
| | | | | .0004 | 1 | |
| | | | | .0004 | 2 | |
| | | | | .0006 | 3 | |
| | | | | .0008 | 21 | |
| | | | | .0016 | 94 | |
| | | | | .0020 | 166 | |
| .0021 | | | | 262 | | |
| Ti-6-4 (TUS 93 TYS 73) | AE-2 | 85 | 800F | 0 | 0 | |
| | | | 800F | .0037 | 1 | |
| | | | 800F | .0058 | 2 | |
| | | | 800F | .0074 | 3 | |
| | | | 800F | .0089 | 4 | |
| | | | 800F | .0265 | 21 | |
| | | | 800F | .0410 | 45 | |
| | | | 800F | .0425 | 69 | |
| 800F | .0425 | 77 | Failed | | | |

TABLE XXV CREEP TEST SUMMARY (Concluded)

| Alloy | Specimen ID | Stress (ksi) | Test Tempo | Creep Strain (in/in) | Time (Hr) | Remarks |
|---------------------------------|-------------|--------------|------------|----------------------|-----------|----------|
| Ti-6-4 | AE-3 | 75 | 800F | 0 | 0 | Unloaded |
| | | | | .0014 | 1 | |
| | | | | .0026 | 2 | |
| | | | | .0032 | 3 | |
| | | | | .0077 | 18 | |
| | | | | .0120 | 43 | |
| | | | | .0183 | 91 | |
| | | | | .0264 | 163 | |
| | | | | .0378 | 259 | |
| | | | | .0431 | 336 | |
| Ti-8-1-1 (TUS 99 TYS 72) | FE-12 | 95 | 800F | 0 | 0 | Failed |
| | | | | .0002 | 2 | |
| | | | | .0003 | 20 | |
| | | | | .0012 | 68 | |
| | | | | .0038 | 139 | |
| | FE-5 | 85 | | 0 | 0 | Unloaded |
| | | | | .0006 | 1 | |
| | | | | .0016 | 18 | |
| | | | | .0028 | 42 | |
| | | | | .0044 | 90 | |
| Ti-6-6-2 (TUS 109 TYS 87) | FE-11 | 72.0 | 800F | .0056 | 162 | Unloaded |
| | | | | .0070 | 258 | |
| | | | | .0084 | 330 | |
| | | | | 0 | 0 | |
| | | | | .0003 | 1 | |
| | .0004 | 2 | | | | |
| | .0006 | 3 | | | | |
| | .0007 | 4 | | | | |
| | .0028 | 92 | | | | |
| | .0039 | 260 | | | | |
| .0043 | 332 | | | | | |
| Ti-6-6-2 (TUS 109 TYS 87) | LE-3 | 98 | 800F | 0 | 0 | Failed |
| | | | | .0190 | 1 | |
| | | | | .0306 | 2 | |
| | | | | .0393 | 3 | |
| | | | | .0474 | 4 | |
| | | | | .1372 | 14 | |

TABLE XXVI RAPID HEAT AND LOAD
CREEP TEST SUMMARY

| Alloy | Specimen ID | Stress (ksi) | Test Temp | Creep Strain (in/in) | Time (min) | Remarks | |
|----------------------------------|-------------|--------------|-----------|----------------------|------------|----------|-------------------|
| Ti-6-4 (TUS 101 TYS 77) | AE-21 | 98 | 600F | 0 | 0 | At load | |
| | | | | .0003 | 1 | | |
| | | | | .0009 | 10 | | |
| | | | | .0015 | 25 | | |
| | | | | .0017 | 40 | | |
| | | | | .0017 | 60 | Unloaded | |
| | AE-22 | 89 | | | 0 | 0 | At load |
| | | | | | .0009 | 5 | |
| | | | | | .0013 | 10 | |
| | AE-23 | 79 | | | .0014 | 60 | Unloaded |
| | | | | | 0 | 0 | At load |
| | | | | | .0002 | 5 | |
| | | | | | .0004 | 10 | |
| | | | | | .0009 | 15 | |
| | | | | | .0012 | 25 | |
| | AE-24 | 71 | | | .0012 | 60 | Unloaded |
| 0 | | | | | 0 | At load | |
| .0012 | | | | | 5 | | |
| .0014 | | | | | 15 | | |
| .0016 | | | | | 20 | | |
| .0017 | | | | | 30 | | |
| Ti-8-1-1 (TUS 107 TYS 81) | FE-16 | 107 | | .0018 | 70 | | |
| | | | | .0018 | 80 | Unloaded | |
| | FE-19 | 103 | | | - | - | Failed on loading |
| | | | | | 0 | 0 | At load |
| | | | | | .0015 | 5 | |
| | | | | | .0018 | 10 | |
| | | | 600F | .0021 | 20 | | |
| | | | | .0024 | 34 | Failed | |

TABLE XXVI RAPID HEAT AND LOAD
 CREEP TEST SUMMARY (Continued)

| Alloy | Specimen ID | Stress (ksi) | Test Temp | Creep Strain (in/in) | Time (min) | Remarks | | | |
|----------------------------------|-------------|--------------|-----------|----------------------|------------|-------------------|-------|---|---------|
| Ti-8-1-1 (TUS 107 TYS 81) | FE-20 | 81 | 600F | 0 | 0 | At load | | | |
| | | | | .0004 | 5 | | | | |
| | | | | .0006 | 60 | Unloaded | | | |
| Ti-6-6-2 (TUS 121 TYS 97) | LE-19 | 119 | 600F | - | 0 | Failed on loading | | | |
| | LE-22 | 112 | | 0 | 0 | At load | | | |
| Ti-6-4 (TUS 93 TYS 73) | LE-22 | 112 | 600F | .0009 | 5 | | | | |
| | | | | .0015 | 10 | | | | |
| | | | | .0018 | 30 | | | | |
| | | | | .0018 | 60 | Unloaded | | | |
| | | | | LE-23 | 100 | 600F | 0 | 0 | At load |
| | | | | | | | .0004 | 5 | |
| | .0005 | 10 | | | | | | | |
| | .0006 | 25 | | | | | | | |
| | .0006 | 60 | Unloaded | | | | | | |
| | LE-24 | 90 | 600F | | | | 0 | 0 | At load |
| | | | | .0006 | 5 | | | | |
| | | | | .0007 | 10 | | | | |
| .0008 | | | | 15 | | | | | |
| .0010 | | | | 25 | | | | | |
| .0010 | | | | 60 | | | | | |
| Ti-6-4 (TUS 93 TYS 73) | AE-9 | 90 | 800F | 0 | 0 | At load | | | |
| | | | | .0027 | 1 | | | | |
| | | | | .0048 | 2 | | | | |
| | | | | .0066 | 3 | | | | |
| | | | | .0081 | 4 | | | | |
| | | | | .0097 | 5 | | | | |
| | | | | .0165 | 10 | | | | |
| | | | | .0335 | 15 | | | | |
| | | .0450 | 20 | | | | | | |
| 90 | 800F | .0585 | 25 | Failed | | | | | |

TABLE XXVI RAPID HEAT AND LOAD
CREEP TEST SUMMARY (Continued)

| Alloy | Specimen ID | Stress (ksi) | Test Temp | Creep Strain (in/in) | Time (min) | Remarks |
|-------------------------------|-------------|--------------|-----------|----------------------|------------|---------|
| Ti-6-4 (TUS 93 TYS 73) | AE-7 | 85 | 800F ↑ | 0 | 0 | At load |
| | | | | .0007 | 5 | |
| | | | | .0012 | 10 | |
| | | | | .0016 | 15 | |
| | | | | .0019 | 25 | |
| | | | | .0020 | 30 | |
| | .0022 | 35 | | | | |
| | .0025 | 45 | | | | |
| | .0028 | 50 | | | | |
| | .0030 | 60 | | Unloaded | | |
| | AE-10 | 79 | | 800F ↑ | 0 | 0 |
| | | | .0006 | | 5 | |
| | | | .0012 | | 10 | |
| | | | .0016 | | 15 | |
| | | | .0019 | | 20 | |
| | | | .0021 | | 25 | |
| | .0023 | 35 | | | | |
| | .0025 | 40 | | | | |
| | .0027 | 50 | | | | |
| | .0029 | 60 | Unloaded | | | |
| | AE-8 | 75 | 800F ↑ | | 0 | 0 |
| .0004 | | | | 5 | | |
| .0007 | | | | 10 | | |
| .0012 | | | | 15 | | |
| .0014 | | | | 20 | | |
| .0016 | | | | 25 | | |
| .0018 | 30 | | | | | |
| .0022 | 40 | | | | | |
| .0024 | 45 | | | | | |
| .0026 | 50 | | | | | |
| .0028 | 60 | Unloaded | | | | |
| AE-12 | 65 | 800F ↑ | 0 | 0 | At load | |
| | | | .0005 | 5 | | |
| | | | .0006 | 10 | | |
| | | | .0007 | 35 | | |
| | | | .0007 | 65 | Unloaded | |

TABLE XXVI RAPID HEAT AND LOAD
CREEP TEST SUMMARY (Continued)

| Alloy | Specimen ID | Stress (ksi) | Test Temp | Creep Strain (in/in) | Time (min) | Remarks |
|---------------------------------|-------------|--------------|-----------|----------------------|------------|-------------------|
| Ti-6-4 | AE-11 | 58 | 800F | 0 | 0 | At load |
| | | | | .0004 | 5 | |
| | | | | .0006 | 10 | |
| | | | | .0008 | 20 | |
| | | | | .0010 | 30 | |
| | | | | .0012 | 35 | |
| | | | | .0012 | 60 | Unloaded |
| Ti-8-1-1 (TUS 99 TYS 72) | FE-7 | 94 | 800F | - | 0 | Failed on loading |
| | FE-8 | 85 | | 0 | 0 | At load |
| .0008 | | | 5 | | | |
| .0010 | | | 10 | | | |
| .0014 | | | 15 | | | |
| .0016 | | | 20 | | | |
| .0018 | | | 45 | | | |
| .0020 | | | 60 | Unloaded | | |
| FE-9 | 72 | 0 | 0 | At load | | |
| | | .0003 | 5 | | | |
| | | .0005 | 10 | | | |
| | | .0006 | 25 | | | |
| | | .0007 | 55 | | | |
| | | .0008 | 70 | Unloaded | | |
| FE-10 | 58 | 0 | 0 | At load | | |
| | | .0002 | 5 | | | |
| | | .0005 | 10 | | | |
| | | .0006 | 15 | | | |
| | | .0008 | 25 | | | |
| | | .0010 | 40 | | | |
| | | .0010 | 70 | Unloaded | | |

TABLE XXVI RAPID HEAT AND LOAD
 CREEP TEST SUMMARY (Continued)

| Alloy | Specimen ID | Stress (ksi) | Test Temp | Creep Strain (in/in) | Time (min) | Remarks |
|----------------------------------|-------------|--------------|-----------|----------------------|------------|----------|
| Ti-6-6-2 (TUS 109 TYS 8/) | LE-10 | 98 | 800F ↑ | 0 | 0 | At load |
| | | | | .0014 | 1 | |
| | | | | .0028 | 2 | |
| | | | | .0038 | 5 | |
| | | | | .0050 | 4 | |
| | | | | .0059 | 5 | |
| | | | | .0106 | 10 | |
| | | | | .0144 | 15 | |
| | | | | .0178 | 20 | |
| | | | | .0209 | 25 | |
| | | | | .0242 | 30 | |
| | | | | .0275 | 35 | |
| | | | | .0305 | 40 | |
| | | | | .0336 | 45 | |
| | | | | .0366 | 50 | |
| | | | | .0396 | 55 | |
| | | | | .0428 | 60 | |
| .0456 | 65 | | | | | |
| | | | | | | Unloaded |
| | LE-7 | 88 | 800F ↓ | 0 | 0 | At load |
| | | | | .0015 | 5 | |
| | | | | .0030 | 10 | |
| | | | | .0039 | 15 | |
| | | | | .0048 | 20 | |
| | | | | .0060 | 25 | |
| | | | | .0067 | 30 | |
| | | | | .0075 | 35 | |
| | | | | .0081 | 40 | |
| | | | | .0087 | 45 | |
| | | | | .0090 | 50 | |
| | | | | .0097 | 55 | |
| | | | | .0105 | 60 | |
| | | | | | | Unloaded |

TABLE XXVI RAPID HEAT AND LOAD
 CREEP TEST SUMMARY (Concluded)

| Alloy | Specimen ID | Stress (ksi) | Test Temp | Creep Strain (in/in) | Time (min) | Remarks |
|----------|-------------|--------------|-----------|----------------------|------------|----------|
| Ti-6-6-2 | LE-9 | 78 | 800F ↑ | 0 | 0 | At load |
| | | | | .0016 | 5 | |
| | | | | .0028 | 10 | |
| | | | | .0037 | 15 | |
| | | | | .0044 | 20 | |
| | | | | .0052 | 25 | |
| | LE-11 | 69 | 800F ↓ | .0060 | 30 | Unloaded |
| | | | | .0067 | 35 | |
| | | | | .0070 | 40 | |
| | | | | .0074 | 45 | |
| | | | | .0078 | 50 | |
| | | | | .0082 | 55 | |
| | | | | .0085 | 60 | |
| Ti-6-6-2 | LE-9 | 78 | 800F ↑ | 0 | 0 | At load |
| | | | | .0008 | 5 | |
| | | | | .0012 | 10 | |
| | | | | .0016 | 15 | |
| | | | | .0022 | 20 | |
| | | | | .0026 | 25 | |
| | LE-11 | 69 | 800F ↓ | .0032 | 35 | Unloaded |
| | | | | .0038 | 40 | |
| | | | | .0042 | 45 | |
| | | | | .0044 | 50 | |
| | | | | .0046 | 55 | |
| | | | | .0048 | 60 | |

TABLE XXVII FATIGUE TEST SUMMARY, $K_T = 1.0$

Range Ratio: $R = .1$ TEST TEMP.: ROOM
 1300 CPM Grain Direction: Longitudinal

| Alloy | Specimen Number | TUS (ksi) | Max Stress Net Area (ksi) | Cycles To Failure | Remarks |
|--------|-----------------|-----------|---------------------------|-------------------|------------|
| Ti-6-4 | CG-21 | 145 | 120 | 57,630 | No Failure |
| | -24 | 110 | 110 | 59,225 | |
| | -16 | 100 | 100 | 219,045 | |
| | -23 | 95 | 95 | 769,125 | |
| | -17 | 90 | 90 | 1,110,525 | |
| | -18 | 85 | 85 | 2,582,037 | |
| | -19 | 80 | 80 | 3,316,840 | |
| | -25 | 78 | 78 | 8,198,675 | |
| | -20 | 75 | 75 | 4,811,562 | |
| | CG-22 | 145 | 72 | 17,774,295 | |
| | DK-46 | 145 | 130 | 36,900 | |
| | -47 | 110 | 110 | 111,780 | |
| | -53 | 100 | 100 | 809,820 | |
| | -48 | 90 | 90 | 220,500 | |
| | -51 | 85 | 85 | 219,780 | |
| | -54 | 82 | 82 | 88,920 | |
| | -49 | 80 | 80 | 2,265,000 | |
| | -55 | 78 | 78 | 7,714,620 | |
| | DK-50 | 145 | 75 | 6,647,400 | |
| | BK-53 | 141 | 120 | 91,025 | |
| -47 | 110 | 110 | 259,500 | | |
| -48 | 100 | 100 | 1,355,750 | | |
| -54 | 95 | 95 | 2,542,250 | | |
| -46 | 90 | 90 | 2,904,700 | | |
| -49 | 85 | 85 | 3,585,250 | | |
| -55 | 82 | 82 | 7,989,600 | | |
| Ti-6-4 | -50 | 141 | 78 | 108,405 | |

TABLE XXVII FATIGUE TEST SUMMARY, $K_T = 1.0$ (Continued)

| Alloy | Specimen Number | TUS (ksi) | Max Stress Net Area (ksi) | Cycles To Failure | Remarks |
|--------------------|-----------------|-----------|---------------------------|-------------------|------------|
| Ti-6-4 | BK-51 | 141 | 78 | 353,405 | |
| | BK-52 | 141 | 76 | 10,039,500 | |
| | EM-11 | 142 | 120 | 34,177 | Heavy Extr |
| | -12 | | 95 | 982,632 | Heavy Extr |
| | -13 | | 76 | 3,512,105 | Heavy Extr |
| | -14 | | 72 | 290,280 | Heavy Extr |
| | EM-15 | 142 | 72 | 10,607,900 | Heavy Extr |
| Ti-6-4 Ti-8-1-1 | HG-24 | 133 | 130 | 25,020 | |
| | -23 | | 105 | 479,700 | |
| | -16 | | 100 | 822,960 | |
| | -17 | | 97 | 792,180 | |
| | -18 | | 90 | 54,360 | |
| | -21 | | 88 | 677,160 | |
| | -25 | | 87 | 1,293,300 | |
| | -19 | | 85 | 6,845,000 | |
| | HG-20 | 133 | 82 | 10,083,600 | No Failure |
| | JK-46 | 134 | 110 | 105,540 | |
| | -47 | | 100 | 90,930 | |
| | -48 | | 90 | 1,734,500 | |
| | -49 | | 85 | 3,678,000 | |
| | -50 | | 82 | 1,045,350 | |
| | -51 | | 80 | 1,768,880 | |
| | -54 | | 77 | 6,349,860 | |
| | -53 | | 75 | 9,160,900 | |
| | JK-55 | 134 | 72 | 8,554,700 | |
| | GK-48 | 140 | 120 | 157,866 | |
| | -46 | | 110 | 445,000 | |
| | -53 | | 105 | 638,750 | |
| Ti-8-1-1 | -51 | 140 | 100 | 71,000 | |

TABLE XXVII FATIGUE TEST SUMMARY, $K_T = 1.0$ (Continued)

| Alloy | Specimen Number | TUS (ksi) | Max Stress Net Area (ksi) | Cycles To Failure | Remarks | | |
|--------------|-----------------|-----------|---------------------------|-------------------|------------|---------|------------|
| Ti8Al-1Mo-1V | GK-52 | 140 | 95 | 1,286,010 | No Failure | | |
| | -47 | ↑ | 90 | 1,159,860 | | | |
| | -49 | ↓ | 85 | 2,004,750 | | | |
| | -54 | ↓ | 82 | 1,969,680 | | | |
| | -50 | ↓ | 61 | 14,170,750 | | | |
| | 3K-55 | 140 | 75 | 13,345,700 | | | |
| | KM-11 | 139 | 120 | 101,723 | | | |
| | -12 | ↑ | 100 | 54,390 | | | |
| | -14 | ↓ | 90 | 212,440 | | | |
| | -13 | ↓ | 80 | 2,541,500 | | | |
| | KM-15 | 139 | 75 | 1,786,640 | | | |
| | Ti6Al-6V-2Sn | NG-18 | 147 | 120 | | 77,040 | No Failure |
| | | -19 | ↑ | 110 | | 429,300 | |
| | | -25 | ↓ | 100 | | 719,100 | |
| -21 | | ↓ | 95 | 854,820 | | | |
| -23 | | ↓ | 92 | 2,823,840 | | | |
| -16 | | ↓ | 90 | 3,631,680 | | | |
| -24 | | ↓ | 88 | 1,601,280 | | | |
| -17 | | ↓ | 85 | 455,400 | | | |
| -22 | | ↓ | 83 | 8,527,320 | | | |
| NG-20 | | 147 | 80 | 10,144,800 | | | |
| FK-51 | | 145 | 120 | 93,250 | | | |
| -49 | | ↑ | 100 | 583,560 | | | |
| -53 | | ↓ | 95 | 1,831,860 | | | |
| -52 | | ↓ | 90 | 2,456,820 | | | |
| -54 | ↓ | 85 | 1,738,800 | | | | |
| -55 | ↓ | 80 | 2,404,800 | | | | |
| -50 | ↓ | 78 | 9,237,600 | | | | |
| -47 | ↓ | 75 | 4,053,900 | | | | |
| Ti-6-0-2 | FK-48 | 145 | 73 | 11,780,000 | No Failure | | |

TABLE XXVII FATIGUE TEST SUMMARY, $K_T = 1.0$ (Concluded)

| Alloy | Specimen Number | TUS (ksi) | Max Stress Net Area (ksi) | Cycles To Failure | Remarks |
|----------|-----------------|-----------|---------------------------|-------------------|------------|
| Ti-6-6-2 | MK-48 | 157 | 120 | 258,660 | |
| | -47 | | 110 | 414,900 | |
| | -46 | | 100 | 987,660 | |
| | -50 | | 95 | 847,080 | |
| | -49 | | 90 | 3,472,560 | |
| | -55 | | 88 | 5,279,940 | |
| | -54 | | 87 | 10,000,000 | No Failure |
| | -51 | 157 | 85 | 6,570,720 | |
| | MK-52 | | 82 | 18,243,000 | No Failure |
| | RM-11 | | 155 | 120 | 41,760 |
| | -15 | 110 | | 448,610 | Thick Extr |
| | -12 | 95 | | 2,297,240 | Thick Extr |
| | -14 | 90 | | 2,844,180 | Thick Extr |
| Ti-6-6-2 | RM-13 | 155 | 82 | 4,830,920 | Thick Extr |

TABLE XXVIII FATIGUE TEST SUMMARY, $K_T = 2.76$, ROOM TEMPERATURE
(Grain Direction: Longitudinal)

| Alloy | Specimen Number | Range Ratio | Max Stress Net Area (ksi) | Cycles To Failure | Remarks | |
|--------|-----------------|-------------|---------------------------|-------------------|-----------|--|
| Ti-6-4 | CG-3 | -1.0 | 50 | 44,798 | | |
| | DK-2 | | 50 | 48,825 | | |
| | BK-5 | | 50 | 22,320 | | |
| | DK-3 | | 40 | 71,145 | | |
| | BK-2 | | 40 | 287,560 | | |
| | CG-1 | | 35 | 509,400 | | |
| | DK-1 | | 35 | 501,500 | | |
| | DK-4 | | 30 | 1,384,000 | | |
| | BK-3 | | 30 | 6,115,700 | | |
| | CG-2 | | 29 | 6,112,000 | | |
| | CG-5 | | 26 | 5,600,000 | | |
| | DK-5 | | -1.0 | 26 | 6,460,000 | |
| | CG-9 | | + .01 | 80 | 23,760 | |
| | BK-19 | 80 | | 19,440 | | |
| | DK-17 | 70 | | 28,426 | | |
| | CG-6 | 65 | | 65,600 | | |
| | DK-19 | 60 | | 39,322 | | |
| | BK-16 | 60 | | 532,260 | | |
| | CG-10 | 55 | | 695,700 | | |
| | DK-16 | 50 | | 838,780 | | |
| | BK-17 | 50 | | 1,895,550 | | |
| | BK-18 | 46 | | 2,567,800 | | |
| | CG-7 | 45 | | 2,256,300 | | |
| | DK-18 | 45 | | 3,931,200 | | |
| | BK-20 | 42 | | 3,000,000 | | |
| | DK-20 | 41 | 797,580 | | | |
| | CG-8 | + .01 | 40 | 2,611,300 | | |
| | DK-31 | + .43 | 93 | 39,060 | | |
| | CG-13 | | 80 | 399,600 | | |
| | BK-33 | | 80 | 52,740 | | |
| | DK-32 | | 75 | 129,600 | | |
| | CG-11 | | 71 | 77,040 | | |
| | BK-34 | | 70 | 1,258,820 | | |
| | CG-12 | | 60 | 2,937,200 | | |
| | DK-33 | | 60 | 1,353,900 | | |
| BK-31 | 60 | | 3,827,100 | | | |
| CG-14 | 57 | | 1,429,500 | | | |
| BK-32 | 56 | | 5,196,500 | | | |
| BK-35 | 55 | | 8,243,100 | | | |
| CG-15 | + .43 | | 54 | 5,770,000 | | |
| Ti-6-4 | | | | | | |

TABLE XXVIII FATIGUE TEST SUMMARY, $K_T = 2.16$, ROOM TEMPERATURE (Continued)

(Grain Direction: Longitudinal)

| Alloy | Specimen Number | Range Ratio | Max Stress Net Area (ksi) | Cycles To Failure | Remarks | | |
|----------|-----------------|-------------|---------------------------|-------------------|------------|------------|------------|
| Ti-8-1-1 | HG-4 | -1.0 | 50 | 19,980 | | | |
| | GK-1 | | 50 | 23,460 | | | |
| | JK-2 | | 45 | 39,420 | | | |
| | GK-4 | | 40 | 48,600 | | | |
| | HG-1 | | 35 | 216,180 | | | |
| | JK-1 | | 35 | 110,700 | | | |
| | GK-2 | | 35 | 1,510,900 | | | |
| | GK-3 | | 32 | 1,715,900 | | | |
| | JK-4 | | 30 | 1,816,500 | | | |
| | HG-2 | | 29 | 2,793,600 | | | |
| | GK-5 | | 29 | 2,638,800 | | | |
| | HG-5 | | 27 | 3,788,100 | | | |
| | JK-3 | | 26 | 1,220,100 | | | |
| | HG-3 | | 25 | 10,776,600 | | | |
| | JK-5 | | 23 | 10,900,000 | | | |
| | | | -1.0 | | | No Failure | |
| | | | -1.0 | | | No Failure | |
| | | | + .01 | 80 | 27,940 | | |
| | | JK-18 | | 75 | 33,120 | | |
| | | HG-8 | | 75 | 37,800 | | |
| | | GK-19 | | 65 | 27,000 | | |
| | | HG-10 | | 65 | 55,965 | | |
| | | JK-16 | | 65 | 485,770 | | |
| | | GK-20 | | 60 | 587,770 | | |
| | | HG-6 | | 50 | 216,470 | | |
| | | JK-17 | | 50 | 663,480 | | |
| | | GK-16 | | 50 | 1,187,400 | | |
| | | HG-7 | | 45 | 1,595,570 | | |
| | | JK-19 | | 42 | 944,640 | | |
| | | HG-9 | | 40 | 11,580,000 | | |
| | | JK-20 | | 36 | 10,700,000 | | |
| | | | | + .01 | | | |
| | | | + .01 | | | No Failure | |
| | | | + .43 | 90 | 70,560 | | |
| | | HG-13 | | 90 | 47,160 | | |
| | GK-35 | 85 | | 26,230 | | | |
| | JK-33 | 80 | | 162,330 | | | |
| | GK-33 | 75 | | 378,540 | | | |
| | GK-34 | 70 | | 394,000 | | | |
| | HG-11 | 65 | | 1,125,700 | | | |
| | HG-12 | 65 | | 340,000 | | | |
| | JK-32 | 62 | | 2,404,600 | | | |
| | HG-14 | 60 | | 655,900 | | | |
| | JK-35 | 60 | | 10,000,000 | | | |
| | GK-31 | 58 | | 9,320,000 | | | |
| | HG-15 | 58 | | | | | |
| Ti-8-1-1 | | + .43 | | | | | No Failure |
| | | + .43 | | | | | No Failure |

TABLE XXVIII FATIGUE TEST SUMMARY, $K_T = 2.76$, ROOM TEMPERATURE (Concluded)
(Grain Direction: Longitudinal)

| Alloy | Specimen Number | Range Ratio | Max Stress Net Area (ksi) | Cycles To Failure | Remarks |
|--|-----------------|-------------|---------------------------|-------------------|------------|
| Ti-6-6-2 | PK-2 | -1.0 | 45 | 52,095 | |
| | NG-1 | | 40 | 25,012 | |
| | NG-4 | | 35 | 134,460 | |
| | PK-1 | | 35 | 240,040 | |
| | MK-3 | | 35 | 595,200 | |
| | NG-2 | | 30 | 499,980 | |
| | PK-4 | | 30 | 1,405,000 | |
| | MK-4 | | 30 | 7,399,000 | |
| | PK-5 | | 28 | 1,693,000 | |
| | PK-3 | | 25 | 10,152,000 | No Failure |
| | NG-3 | -1.0 | 25 | 11,130,000 | No Failure |
| | NG-8 | + .01 | 75 | 27,000 | |
| | PK-19 | | 75 | 30,960 | |
| | MK-18 | | 70 | 25,920 | |
| | NG-6 | | 60 | 329,580 | |
| | PK-17 | | 60 | 48,240 | |
| | MK-19 | | 60 | 353,700 | |
| | NG-7 | | 50 | 2,536,200 | |
| | PK-16 | | 50 | 833,940 | |
| | MK-17 | | 50 | 1,800,000 | |
| | PK-18 | | 45 | 3,608,400 | |
| | NG-10 | | 45 | 12,636,800 | No Failure |
| | MK-20 | | 44 | 11,914,000 | No Failure |
| | PK-20 | | 42 | 10,000,000 | No Failure |
| | MK-16 | + .01 | 40 | 7,506,000 | No Failure |
| | NG-14 | + .43 | 90 | 37,080 | |
| | MK-32 | | 85 | 28,620 | |
| | NG-15 | | 80 | 81,540 | |
| | PK-32 | | 80 | 36,900 | |
| | MK-35 | | 80 | 801,000 | |
| | NG-11 | | 75 | 895,500 | |
| | MK-33 | | 75 | 746,860 | |
| | PK-31 | | 70 | 46,800 | |
| | MK-31 | | 70 | 3,643,200 | |
| NG-12 | | 67 | 1,036,600 | | |
| MK-34 | | 67 | 10,000,000 | No Failure | |
| Ti-6-6-2 | NG-13 | + .43 | 64 | 1,566,180 | |
| ① K_T Based on Net Areas ② Range Ratio $R = \text{Minimum Stress/Maximum Stress}$ | | | | | |

TABLE XXIX FATIGUE TEST SUMMARY, $K_T = 2.76$

Test Temperature: 400°F
Grain Direction: Longitudinal

| Alloy | Specimen Number | Range Ratio | Max Stress Net Area (ksi) | Cycles To Failure | Remarks |
|--------|-----------------|-------------|---------------------------|-------------------|---------|
| Ti-6-4 | BK-7 | -1.0 | 45 | 16,920 | |
| | DK-6 | | 40 | 56,832 | |
| | DK-9 | | 35 | 66,040 | |
| | BK-6 | | 35 | 40,500 | |
| | BK-9 | | 33 | 63,720 | |
| | DK-7 | | 30 | 519,400 | |
| | BK-8 | | 30 | 3,129,400 | |
| | BK-10 | | 27 | 2,008,200 | |
| | DK-10 | -1.0 | 25 | 1,372,500 | |
| | DK-22 | + .01 | 65 | 23,220 | |
| | BK-23 | | 61 | 42,122 | |
| | DK-21 | | 55 | 37,620 | |
| | BK-24 | | 50 | 1,809,300 | |
| | BK-25 | | 46 | 1,371,600 | |
| | DK-23 | | 45 | 1,658,800 | |
| | DK-24 | | 42 | 5,104,700 | |
| | DK-25 | + .01 | 40 | 3,983,200 | |
| Ti-6-4 | BK-37 | + .43 | 80 | 19,440 | |

TABLE XXIX FATIGUE TEST SUMMARY, $K_T = 2.76$ (Continued)

| Alloy | Specimen Number | Range Ratio | Max Stress Net Area (ksi) | Cycles To Failure | Remarks |
|----------|-----------------|-----------------|---------------------------|-------------------|------------|
| Ti-6-4 | BK-38 | ↑ + .43 ↓ | 72 | 391,320 | |
| | DK-36 | | 70 | 34,920 | |
| | BK-36 | | 65 | 528,900 | |
| | BK-40 | | 63 | 1,854,000 | |
| | DK-37 | | 60 | 880,740 | |
| | DK-40 | | 47 | 10,253,300 | |
| Ti-6-4 | DK-39 | + .43 | 45 | 11,043,000 | No Failure |
| Ti-8-1-1 | GK-6 | ↑ -1.0 ↓ | 45 | 29,260 | |
| | JK-6 | | 40 | 18,012 | |
| | JK-7 | | 30 | 2,182,400 | |
| | GK-7 | | 30 | 1,131,170 | |
| | JK-8 | | 27 | 1,273,100 | |
| | JK-10 | | 25 | 1,586,500 | |
| | GK-9 | | -1.0 | 25 | |
| | GK-22 | ↑ + .01 ↓ | 65 | 23,708 | |
| | JK-21 | | 60 | 50,837 | |
| | JK-25 | | 55 | 109,980 | |
| | GK-24 | | 55 | 353,700 | |
| JK-22 | 50 | 357,180 | | | |
| Ti-8-1-1 | GK-21 | + .01 | 50 | 393,120 | |

TABLE XXIX FATIGUE TEST SUMMARY, $K_T = 2.76$ (Continued)

| Alloy | Specimen Number | Range Ratio | Max Stress Net Area (ksi) | Cycles To Failure | Remarks |
|----------|-----------------|-------------|---------------------------|-------------------|---------|
| Ti-8-1-1 | JK-23 | + .01 | 47 | 103,020 | |
| | GK-23 | ↕ | 45 | 12,585,500 | |
| | JK-24 | + .01 | 40 | 7,530,240 | |
| | GK-37 | + .43 | 80 | 287,460 | |
| | JK-37 | ↕ | 75 | 92,700 | |
| | GK-38 | ↕ | 75 | 202,680 | |
| | JK-36 | ↕ | 65 | 1,691,200 | |
| | GK-36 | ↕ | 65 | 1,007,100 | |
| | JK-40 | ↕ | 63 | 2,674,800 | |
| | GK-40 | ↕ | 60 | 2,050,900 | |
| | Ti-8-1-1 | JK-39 | + .43 | 58 | |
| Ti-6-6-2 | MK-9 | -1.0 | 50 | 16,790 | |
| | MK-7 | ↕ | 40 | 1,532,500 | |
| | FK-7 | ↕ | 30 | 33,320 | |
| | MK-6 | ↕ | 30 | 4,808,700 | |
| | FK-10 | ↕ | 28 | 1,963,900 | |
| | FK-8 | ↕ | 25 | 3,120,300 | |
| | FK-9 | -1.0 | 22 | 10,504,000 | |
| Ti-6-6-2 | MK-24 | + .01 | 70 | 30.96C | |

TABLE XXIX FATIGUE TEST SUMMARY, $K_T = 2.76$ (Concluded)

| Alloy | Specimen Number | Range Ratio | Max Stress Net Area (ksi) | Cycles To Failure | Remarks |
|----------|-----------------|-------------|---------------------------|-------------------|------------|
| Ti-6-6-2 | PK-22 | + .01 | 67 | 22,140 | No Failure |
| | PK-23 | | 55 | 400,640 | |
| | MK-21 | | 50 | 475,920 | |
| | PK-24 | | 46 | 552,500 | |
| | MK-23 | | 46 | 1,658,500 | |
| | MK-25 | | 42 | 18,478,200 | |
| | PK-25 | + .01 | 40 | 1,182,300 | |
| | MK-39 | + .43 | 90 | 26,460 | |
| | MK-37 | | 80 | 659,160 | |
| | MK-36 | | 75 | 882,900 | |
| | PK-36 | | 70 | 52,200 | |
| | MK-38 | | 70 | 1,896,800 | |
| | MK-40 | | 67 | 842,760 | |
| | PK-38 | | 62 | 68,220 | |
| | PK-40 | | 60 | 7,894,600 | |
| | PK-37 | | 55 | 5,785,500 | |
| Ti-6-6-2 | PK-39 | + .43 | 50 | 8,649,500 | |

TABLE XXX FATIGUE TEST SUMMARY $K_T = 2.76$, 600°F
 (Grain Direction: Longitudinal)

| Alloy | Specimen Number | Range Ratio | Max Stress Net Area (ksi) | Cycles To Failure | Remarks | | |
|----------|-----------------|-------------|---------------------------|-------------------|------------|------------|--|
| Ti-6-4 | DK-13 | -1.0 | 40 | 23,800 | | | |
| | BK-15 | ↑ | 40 | 22,120 | | | |
| | DK-12 | ↑ | 30 | 711,180 | | | |
| | BF 11 | ↑ | 30 | 2,569,800 | | | |
| | DK-14 | ↑ | 25 | 3,533,800 | | | |
| | BK-12 | ↑ | 25 | 1,808,500 | | | |
| | BK-14 | ↑ | 23 | 3,252,400 | | | |
| | DK-15 | -1.0 | 20 | 3,456,000 | | | |
| | BK-27 | + .01 | 78 | 14,766 | | | |
| | DK-27 | ↑ | 62 | 14,400 | | | |
| | DK-26 | ↑ | 55 | 287,270 | | | |
| | BK-29 | ↑ | 50 | 45,720 | | | |
| | BK-26 | ↑ | 51 | 991,430 | | | |
| | DK-28 | ↑ | 48 | 1,714,600 | | | |
| | BK-28 | ↑ | 45 | 78,840 | | | |
| | DK-29 | ↑ | 43 | 2,356,500 | | | |
| | DK-30 | ↑ | 40 | 4,001,900 | | | |
| | BK-30 | + .01 | 35 | 10,000,000 | | No Failure | |
| | Ti-6-4 | BK-43 | + .43 | 75 | | 34,560 | |
| | | DK-42 | ↑ | 70 | | 43,740 | |
| DK-44 | | ↑ | 65 | 3,176,600 | | | |
| BK-41 | | ↑ | 65 | 1,860,700 | | | |
| DK-41 | | ↑ | 60 | 2,475,500 | | | |
| BK-42 | | ↑ | 60 | 337,500 | | | |
| DK-45 | | ↑ | 55 | 10,000,000 | No Failure | | |
| BK-44 | | ↑ | 53 | 3,156,300 | | | |
| BK-45 | | + .43 | 50 | 12,702,600 | No Failure | | |
| Ti-8-1-1 | | GK-12 | -1.0 | 40 | 28,860 | | |
| | JK-11 | ↑ | 35 | 25,560 | | | |
| | GK-11 | ↑ | 30 | 446,110 | | | |
| | JK-14 | ↑ | 28 | 731,160 | | | |
| | GK-15 | ↑ | 26 | 2,088,700 | | | |
| | JK-15 | ↑ | 24 | 3,511,400 | | | |
| | GK-14 | -1.0 | 24 | 10,386,000 | No Failure | | |
| | JK-26 | + .01 | 60 | 44,415 | | | |
| | JK-29 | ↑ | 55 | 208,580 | | | |
| | GK-26 | ↑ | 50 | 794,000 | | | |
| Ti-8-1-1 | JK-27 | ↑ | 45 | 1,208,500 | | | |
| | GK-28 | + .01 | 45 | 205,000 | | | |

TABLE XXX FATIGUE TEST SUMMARY $K_T = 2.76$, 600°F (Continued)
 (Grain Direction: Longitudinal)

| Alloy | Specimen Number | Range Ratio | Max Stress Net Area (ksi) | Cycles To Failure | Remarks |
|---------------|-----------------|-------------|---------------------------|-------------------|--------------------------|
| Ti-8-1-1 ↑ | GK-29 | +0.01 | 42 | 2,304,900 | No Failure |
| | JK-28 | ↓ | 40 | 8,229,300 | |
| | JK-30 | | 38 | 4,847,300 | |
| | GK-30 | +0.01 | 37 | 10,292,500 | |
| | GK-45 | +0.43 | 90 | 22,860 | |
| | GK-43 | ↑ | 80 | 312,750 | |
| | JK-42 | | 75 | 55,620 | |
| | JK-43 | ↓ | 72 | 176,820 | |
| | GK-41 | | 70 | 637,970 | |
| | JK-41 | | 65 | 1,136,200 | |
| | GK-42 | ↓ | 63 | 683,350 | |
| | JK-44 | | 60 | 761,000 | |
| | GK-44 | | 57 | 10,000,000 | |
| | JK-45 | +0.43 | 56 | 10,000,000 | |
| Ti-8-1-1 ↓ | | | | No Failure | |
| Ti-6-6-2 ↑ | PK-12 | -1.0 | 40 | 35,520 | No Failure No Failure |
| | MK-15 | ↑ | 40 | 163,020 | |
| | PK-15 | | 35 | 417,180 | |
| | PK-11 | ↓ | 30 | 436,850 | |
| | MK-11 | | 30 | 1,080,200 | |
| | PK-13 | ↓ | 26 | 6,086,800 | |
| | MK-14 | | 25 | 15,528,000 | |
| | PK-14 | -1.0 | 24 | 10,310,000 | |
| | MK-28 | +0.01 | 65 | 42,282 | |
| | PK-26 | ↑ | 60 | 28,080 | |
| | MK-30 | | 60 | 239,180 | |
| | PK-28 | ↓ | 50 | 127,260 | |
| | MK-26 | | 50 | 383,220 | |
| | MK-27 | | 45 | 2,175,000 | |
| | PK-27 | ↓ | 43 | 3,586,500 | |
| | MK-29 | | 42 | 10,000,000 | |
| | PK-30 | | 40 | 10,000,000 | |
| | PK-29 | +0.01 | 38 | 12,760,000 | |
| | MK-44 | +0.43 | 90 | 10,800 | |
| | PK-43 | ↑ | 80 | 23,400 | |
| | MK-42 | | 80 | 356,220 | |
| | PK-41 | ↓ | 78 | 11,000 | |
| | PK-42 | | 70 | 2,397,700 | |
| | MK-41 | | 70 | 3,004,900 | |
| Ti-6-6-2 ↓ | MK-45 | +0.43 | 63 | 2,366,200 | |

UNCLASSIFIED

Security Classification

DOCUMENT CONTROL DATA - R&D

(Security classification of title, body of abstract and indexing annotation must be entered when the overall report is classified)

| | |
|--|--|
| 1. ORIGINATING ACTIVITY (Corporate author) LOCKHEED-CALIFORNIA COMPANY BURBANK, CALIFORNIA | 2a. REPORT SECURITY CLASSIFICATION UNCLASSIFIED |
| | 2b. GROUP |

6 DEVELOPMENT OF ENGINEERING DATA ON TITANIUM EXTRUSION FOR USE IN AEROSPACE DESIGN.

9 SUMMARY TECHNICAL REPORT - 27 Jun 66 - 31 May 67

10 R. M. BROCKETT
A. GOTTBRATH

| | | | |
|------------------|------------|---|-----------------|
| 11 Jul 67 | 12 220p. | 7a. TOTAL NO. OF PAGES 195 | 7b. NO. OF REFS |
| 15 133(615)-5080 | 16 AF-7381 | 9a. ORIGINATOR'S REPORT NUMBER(S) 18 AFML 19 TR-67-189 | |
| c. | 17 738106 | 9b. OTHER REPORT NO(S) (Any other numbers that may be assigned this report) | |
| d. | | | |

10. AVAILABILITY/LIMITATION NOTICES

| | |
|-------------------------|---|
| 11. SUPPLEMENTARY NOTES | 12. SPONSORING MILITARY ACTIVITY AIR FORCE MATERIALS LABORATORY, RFD, AIR FORCE SYSTEMS COMMAND WRIGHT PATTERSON AFB, OHIO |
|-------------------------|---|

13. ABSTRACT

Mechanical property data for Ti6Al-4V, Ti8Al-1Mo-1V and Ti6Al-6V-2Sn extruded shapes in annealed tempers were obtained at test temperatures from -110°F to +800°F to provide a base for development of design information for these materials. Data obtained included ultimate tensile strength, tensile yield strength, compressive yield strength, shear bearing, impact properties, creep, stress-rupture, fatigue and fracture toughness characteristics.

Separate heats of material in each of the three alloys were obtained from separate suppliers. Two section sizes were obtained from one of the suppliers to provide information on size effects. Tests conducted to provide data insofar as practicable within the scope of this program on property variations and on scatter.

Results of testing indicate that with consideration of effect of temperatures used in extrusion processing, extrusions may be utilized in the same manner as titanium materials produced by other methods such as rolling or forging. Data obtained generally indicates that extruded material may be expected to have not only the cost advantages which result from economy of shape design, but will possess advantages in developed fracture characteristics and creep characteristics when compared with conventional alpha-beta processing of rolled or forged materials.

(Distribution of this abstract is unlimited) (209970)

DD FORM 1473 1 JAN 64

UNCLASSIFIED Security Classification

mlh

UNCLASSIFIED

Security Classification

| 14. KEY WORDS | LINK A | | LINK B | | LINK C | |
|--------------------------|--------|----|--------|----|--------|----|
| | ROLE | WT | ROLE | WT | ROLE | WT |
| TITANIUM EXTRUSIONS | | | | | | |
| MECHANICAL PROPERTIES | | | | | | |
| Ti-6Al-4V EXTRUSIONS | | | | | | |
| Ti-8Al-1Mo-1V EXTRUSIONS | | | | | | |
| Ti-6Al-6V-2Sn EXTRUSIONS | | | | | | |

INSTRUCTIONS

1. **ORIGINATING ACTIVITY:** Enter the name and address of the contractor, subcontractor, grantee, Department of Defense activity or other organization (corporate author) issuing the report.

2a. **REPORT SECURITY CLASSIFICATION:** Enter the overall security classification of the report. Indicate whether "Restricted Data" is included. Marking is to be in accordance with appropriate security regulations.

2b. **GROUP:** Automatic downgrading is specified in DoD Directive 5200.10 and Armed Forces Industrial Manual. Enter the group number. Also, when applicable, show that optional markings have been used for Group 3 and Group 4 as authorized.

3. **REPORT TITLE:** Enter the complete report title in all capital letters. Titles in all cases should be unclassified. If a meaningful title cannot be selected without classification, show title classification in all capitals in parenthesis immediately following the title.

4. **DESCRIPTIVE NOTES:** If appropriate, enter the type of report, e.g., interim, progress, summary, annual, or final. Give the inclusive dates when a specific reporting period is covered.

5. **AUTHOR(S):** Enter the name(s) of author(s) as shown on or in the report. Enter: last name, first name, middle initial. If military, show rank and branch of service. The name of the principal author is an absolute minimum requirement.

6. **REPORT DATE:** Enter the date of the report as day, month, year, or month, year. If more than one date appears on the report, use date of publication.

7a. **TOTAL NUMBER OF PAGES:** The total page count should follow normal pagination procedures, i.e., enter the number of pages containing information.

7b. **NUMBER OF REFERENCES:** Enter the total number of references cited in the report.

8a. **CONTRACT OR GRANT NUMBER:** If appropriate, enter the applicable number of the contract or grant under which the report was written.

8b, 8c, & 8d. **PROJECT NUMBER:** Enter the appropriate military department identification, such as project number, subproject number, system numbers, task number, etc.

9a. **ORIGINATOR'S REPORT NUMBER(S):** Enter the official report number by which the document will be identified and controlled by the originating activity. This number must be unique to this report.

9b. **OTHER REPORT NUMBER(S):** If the report has been assigned any other report numbers (either by the originator or by the sponsor), also enter this number(s).

10. **AVAILABILITY/LIMITATION NOTICES:** Enter any limitations on further dissemination of the report, other than those

imposed by security classification, using standard statements such as:

- (1) "Qualified requesters may obtain copies of this report from DDC."
- (2) "Foreign announcement and dissemination of this report by DDC is not authorized."
- (3) "U. S. Government agencies may obtain copies of this report directly from DDC. Other qualified DDC users shall request through _____."
- (4) "U. S. military agencies may obtain copies of this report directly from DDC. Other qualified users shall request through _____."
- (5) "All distribution of this report is controlled. Qualified DDC users shall request through _____."

If the report has been furnished to the Office of Technical Services, Department of Commerce, for sale to the public, indicate this fact and enter the price, if known.

11. **SUPPLEMENTARY NOTES:** Use for additional explanatory notes.

12. **SPONSORING MILITARY ACTIVITY:** Enter the name of the departmental project office or laboratory sponsoring (paying for) the research and development. Include address.

13. **ABSTRACT:** Enter an abstract giving a brief and factual summary of the document indicative of the report, even though it may also appear elsewhere in the body of the technical report. If additional space is required, a continuation sheet shall be attached.

It is highly desirable that the abstract of classified reports be unclassified. Each paragraph of the abstract shall end with an indication of the military security classification of the information in the paragraph, represented as (TS), (S), (C), or (U).

There is no limitation on the length of the abstract. However, the suggested length is from 150 to 225 words.

14. **KEY WORDS:** Key words are technically meaningful terms or short phrases that characterize a report and may be used as index entries for cataloging the report. Key words must be selected so that no security classification is required. Identifiers, such as equipment model designation, trade name, military project code name, geographic location, may be used as key words but will be followed by an indication of technical context. The assignment of links, rules, and weights is optional.

UNCLASSIFIED

Security Classification