

UNCLASSIFIED

AD NUMBER
AD820790
NEW LIMITATION CHANGE
TO Approved for public release, distribution unlimited
FROM Distribution authorized to U.S. Gov't. agencies and their contractors; Critical Technology; JUL 1967. Other requests shall be referred to Air force Flight Dynamics Laboratory, Attn: FDCC, Wright-Patterson AFB, OH.
AUTHORITY
AFFDL ltr, 25 Oct 1972

THIS PAGE IS UNCLASSIFIED

AFFDL-TR-67-51

AD820790

**IN-FLIGHT SIMULATION AND PILOT EVALUATION OF
SELECTED LANDING APPROACH HANDLING QUALITIES
OF A LARGE LOGISTICS TRANSPORT AIRPLANE**

DONALD W. RHOADS

CORNELL AERONAUTICAL LABORATORY, INC.

TECHNICAL REPORT AFFDL-TR-67-51

JULY 1967

This document is subject to special export controls and each transmittal to foreign governments or foreign nationals may be made only with prior approval of the Air Force Flight Dynamics Laboratory (FDCC), Wright-Patterson Air Force Base, Ohio 45433.

**AIR FORCE FLIGHT DYNAMICS LABORATORY
RESEARCH AND TECHNOLOGY DIVISION
AIR FORCE SYSTEMS COMMAND
WRIGHT-PATTERSON AIR FORCE BASE, OHIO**

NOTICES

When Government drawings, specifications, or other data are used for any purpose other than in connection with a definitely related Government procurement operation, the United States Government thereby incurs no responsibility nor any obligation whatsoever; and the fact that the Government may have formulated, furnished, or in any way supplied the said drawings, specifications, or other data, is not to be regarded by implication or otherwise as in any manner licensing the holder or any other person or corporation, or conveying any rights or permission to manufacture, use, or sell any patented invention that may in any way be related thereto.

Copies of this report should not be returned to the Research and Technology Division unless return is required by security considerations, contractual obligations, or notice on a specific document.

**IN-FLIGHT SIMULATION AND PILOT EVALUATION OF
SELECTED LANDING APPROACH HANDLING QUALITIES
OF A LARGE LOGISTICS TRANSPORT AIRPLANE**

DONALD W. RHOADS

CORNELL AERONAUTICAL LABORATORY, INC.

This document is subject to special export controls and each transmittal to foreign governments or foreign nationals may be made only with prior approval of the Air Force Flight Dynamics Laboratory (FDCC), Wright-Patterson Air Force Base, Ohio 45433.

FOREWORD

This report was prepared for the Air Force Flight Dynamics Laboratory, Research and Technology Division, Air Force Systems Command, Wright-Patterson Air Force Base, Ohio, by the Cornell Aeronautical Laboratory, Inc., (CAL), Buffalo, New York in partial fulfillment of Contract No. AF33(615)-3955 (Project No. 8219, Task No. 821905).

The system design work described herein was performed by the CAL Flight Research Department. The pilot evaluation experiments were designed by the CAL Flight Research Department in cooperation with representatives of the Lockheed-Georgia Company.

Mr. Richard O. Sickeler was project engineer for the Air Force.

Evaluation pilots were Captain Gervasio Tonini, USAF, Mr. Henry Dees, Lockheed-Georgia, and Mr. Gifford Bull, CAL.

This manuscript was released by the author 7 February 1967 for publication as an AFFDL Technical Report. It is also being published as Cornell Aeronautical Laboratory Report No. TB-2282-F-2.

Funds for this program came from the Air Force Flight Dynamics Laboratory Director's Fund.

This technical report has been reviewed and is approved.



C. B. Westbrook
Chief, Control Criteria Branch
Flight Control Division
Air Force Flight Dynamics Laboratory

ABSTRACT

A simulation program examined selected handling qualities of a large logistics transport airplane in the landing approach, considering both longitudinal and lateral-directional characteristics. A variable stability B-26 airplane was used as an in-flight simulator. The longitudinal short-period frequency and damping ratio and the stick force per normal acceleration were varied using a model-following technique. The Dutch roll frequency and damping ratio, the amplitude of the bank angle to sideslip ratio (at the Dutch roll frequency) and the roll mode time constant were adjusted to simulate stability augmentation system on and off using the response-feedback technique. Lateral control was investigated with various amounts of maximum control power and two different amounts of control system time lag. The pilots performed general airwork and made ILS approaches, some with lateral offset. The landing flare and touchdown were not included in the evaluation. The results of this program are presented in terms of acceptability to the pilots, based upon a numerical rating and detailed comments. Three evaluation pilots participated. Regardless of longitudinal parameter variation, the majority of pilot evaluation data fell in the "acceptable but unsatisfactory" category. Most noted was the sluggishness in pitch (slightly improved in the augmented configuration) and high stick travel per incremental normal acceleration. Opinion was divided as to the relative desirability of the two values of stick force per incremental normal acceleration evaluated. Parameter variations in the lateral-directional evaluation yielded data which extended from the "acceptable but unsatisfactory" category to the "unflyable" category. Results were strongly influenced by the piloting difficulties associated with the changes in the rudder coordination requirements during turns. From the data obtained, it was difficult to specify minimum roll control requirements for this mission with assurance. Generally, a $pb/2U$ no greater than 0.2 and ϕ , no greater than 4° appeared sufficient for two of the evaluation pilots. The third pilot, however, desired larger values.

This abstract is subject to special export controls and each transmittal to foreign governments or foreign nationals may be made only with prior approval of the Air Force Flight Dynamics Laboratory (FDCC), Wright-Patterson Air Force Base, Ohio 45433.

TABLE OF CONTENTS

<u>Section</u>	<u>Page</u>
I Introduction	1
II System Capability and Mechanization	2
1. Longitudinal	2
2. Lateral-Directional	3
3. Miscellaneous Installations	4
4. Limitations and Differences	5
5. Turbulence Response Simulation	6
III Preliminary Analysis	8
IV Configuration Simulation	10
V Evaluation Task and Procedures	13
VI Discussion	17
1. General	17
2. Longitudinal	17
3. Lateral-Directional	18
VII Conclusions.	20
Longitudinal Evaluation.	20
Lateral-Directional Evaluation	20
VIII Recommendations.	22
References	23
Appendix I - Large Airplane Data and Equations of Motion	53
Longitudinal	53
Lateral-Directional	55
Appendix II - Evaluation Pilot Flight Experience	57

LIST OF ILLUSTRATIONS

<u>Figure</u>		<u>Page</u>
1	B-26 Three-Axis Variable Stability Airplane	24
2	B-26 Cockpit, Safety Pilot's Position on Left, Evaluation Pilot's Position on Right	24
3	Computer (Model) Installation in B-26 Waist Compartment, Looking Forward	25
4	Variable Stability Installation in B-26 Bomb Bay, Looking Forward	25
5	Aircraft Motion Sign Conventions; Response to Positive Control Column Inputs.	26
6	Longitudinal Model-Following Technique	27
7	Lateral-Directional Response Feedback Simulation Technique Showing Gains Used	28
8	Nonlinear Roll Control Power Curves Approximated by Function Generator.	29
9	Program Diagram	30
10	Model Pitch Response and Airplane Pitch Response Error to $3^\circ \delta_e$ Step Command to Model -- Unaugmented Case.	31
11	Model Pitch Response and Airplane Pitch Response Error to a 20% Thrust Step Input -- Unaugmented Case	32
12	Model Pitch Response and Airplane Pitch Response Error During Sharp Random Pilot-Applied Control Inputs -- Unaugmented Case	33
13	Model Pitch Response and Airplane Pitch Response Error to $3^\circ \delta_e$ Step Command to Model -- Augmented Case	34
14	Model Pitch Response and Airplane Pitch Response Error to a 20% Thrust Step Input -- Augmented Case.	35
15	Model Pitch Response and Airplane Pitch Response Error During Sharp Random Pilot-Applied Control Inputs -- Augmented Case.	36
16	Initial θ Response Comparison to $3^\circ \delta_e$ Step Command	37
17	Initial $\dot{\theta}$ and $\ddot{\theta}$ Responses Derived from Figure 16.	37
18	Range of ϕ , Investigated	38
19	Typical Comparison of Lateral-Directional Responses, Unaugmented Case, $1^\circ \delta_{AB}$ Step Input	39
20	Typical Comparison of Lateral-Directional Responses, Augmented Case, $1^\circ \delta_{AB}$ Step Input	40
21	Geometry of Offset Maneuver	41

LIST OF ILLUSTRATIONS
(CONTINUED)

<u>Figure</u>		<u>Page</u>
22	Longitudinal Evaluation -- Pilot A, Ratings Include Lateral-Directional Characteristics	42
23	Longitudinal Evaluation -- Pilot B, Ratings Include Lateral-Directional Characteristics	43
24	Longitudinal Evaluation -- Pilot B, Ratings Based on Longitudinal Characteristics Only	44
25	Longitudinal Evaluation -- Pilot B, Change in Average Ratings When Lateral-Directional as well as Longitudinal Characteristics are Considered	45
26	Longitudinal Evaluation -- Pilot C, Ratings Include Lateral-Directional Characteristics	46
27	Longitudinal Evaluation -- Comparison of Individual Averaged Pilot Data	47
28	Lateral-Directional Evaluation -- Pilot A, Effect of $pb/2U$. Ratings Include Longitudinal Characteristics.	48
29	Lateral-Directional Evaluation -- Pilot A, Effect of ϕ_r . Ratings Include Longitudinal Characteristics.	48
30	Lateral-Directional Evaluation -- Pilot B, Effect of $pb/2U$. Ratings Include Longitudinal Characteristics.	49
31	Lateral-Directional Evaluation -- Pilot B, Effect of ϕ_r . Ratings Include Longitudinal Characteristics.	49
32	Lateral-Directional Evaluation -- Pilot C, Effect of $pb/2U$. Ratings Include Longitudinal Characteristics.	50
33	Lateral-Directional Evaluation -- Pilot C, Effect of ϕ_r . Ratings include Longitudinal Characteristics.	50
34	Pilot Comparison of Lateral-Directional Evaluation, Unaugmented Configuration	51
35	Pilot Comparison of Lateral-Directional Evaluation, Augmented Configuration	52

SYMBOLS AND DEFINITIONS

Dimensional Units

Distance - feet	Time - seconds
Angle - radians or degrees	Force - pounds
Moment - foot-pounds	Mass - slugs

b	wing span
c	wing chord
C_D	drag coefficient, drag/ qS
C_L	lift coefficient, lift/ qS
C_R	rolling moment coefficient, L/qSb
C_M	pitching moment coefficient, M/qSc
C_N	yawing moment coefficient, N/qSb
F_{AS}	aileron stick (wheel) force
F_{ES}	elevator stick (wheel) force
F_{RP}	rudder pedal force
f_p	undamped phugoid frequency, Hertz
f_{sp}	undamped short period frequency, Hertz
g	gravitational constant
h	altitude
$\dot{h} = \frac{dh}{dt}$	time rate of change of altitude
I_x	moment of inertia about the x stability axis
I_y	moment of inertia about the y stability axis
I_z	moment of inertia about the z stability axis
L	rolling moment about the x stability axis
M	pitching moment about the y stability axis
m	mass of the airplane
N	yawing moment about the z stability axis

n_y	acceleration along y axis, g units
n_z	acceleration along z axis, g units
P_M	manifold pressure
p	rolling velocity about x stability axis
$\dot{p} = \frac{dp}{dt}$	rolling acceleration about x stability axis
q	pitching velocity about y stability axis
$\dot{q} = \frac{dq}{dt}$	pitching acceleration about y stability axis
\bar{q}	dynamic pressure
r	yawing velocity about z stability axis
$\dot{r} = \frac{dr}{dt}$	yawing acceleration about z stability axis
S	wing area
∇	Laplace operator
T	thrust force
T_d	Dutch roll period (damped)
U, V	flight path velocity
u	velocity along x stability axis
v	velocity along y stability axis
w	velocity along z stability axis
W	weight
X	force along the x stability axis
Y	force along the y stability axis
Z	force along the z stability axis
α	angle of attack
α_v	angle of attack measured at the vane
β	angle of sideslip

δ_a	aileron deflection
δ_{AS}	aileron stick (wheel) deflection
δ_e	elevator deflection
δ_{ES}	elevator stick (wheel) deflection
δ_r	rudder deflection
δ_{RP}	rudder pedal deflection
δ_T	throttle deflection
ϵ	error
ζ_d	Dutch roll damping ratio
ζ_p	phugoid damping ratio
ζ_{SP}	short period damping ratio
Θ	pitch angle
ρ	air density
τ_e	roll mode time constant
Φ	bank angle
Φ_1	bank angle obtained in one second
$ \frac{\Phi}{\beta} _d$	magnitude of roll to sideslip ratio in the Dutch roll mode
ω_p	undamped phugoid frequency, rad/sec
ω_{SP}	undamped short period frequency, rad/sec

Stability derivative notation is given in the appendix with the equations of motion.

Subscripts

- a airplane
- c command
- m model
- 0 initial value

A "Δ" in front of a variable denotes incremental value.

SECTION I INTRODUCTION

The work described in this report is part of a continued effort to determine relationships between design parameters and handling qualities of large aircraft, using in-flight simulation as a primary instrument of investigation (References 1, 2, and 3).

The large aircraft, because of its relatively large ratio of inertia to aerodynamic force, is often characterized by well-known slow and ponderous responses to control inputs. Control power is a predominant design parameter because of the necessity to overcome and position large inertias at low levels of aerodynamic force. These characteristics are likely to be extremely significant during the ILS approach phase of flight, where the airspeed is low and the task demands concentration and precision of maneuver by the pilot.

Because of the above, the piloting task for this investigation was designed primarily about the ILS approach maneuver; and the pilots examined the suitability of a range of variations in stick force per incremental normal acceleration, and in roll control power.

The simulated airplane configurations are termed "unaugmented" and "augmented" and represent different dynamic characteristics. The augmented case does not represent any specific stability augmentation system. Previous work (Reference 1) dealt with a large airplane representation made up of a combination of characteristics obtained from various manufacturers interested in the C-5A concept. The present simulation is based on data obtained from Lockheed-Georgia. However, it must be emphasized that this simulation is based on C-5A data estimated by Lockheed-Georgia as of April 1966 (Reference 4), and since that time, several design changes in the longitudinal and lateral-directional modes have been made, both in the unaugmented and augmented configurations. Therefore, this effort should be considered a parametric study based on the general characteristics of a large airplane, and relationship to the present C-5A design must be qualified.

In order to perform this study, considerable attention was given to: 1) adequate simulation of the configurations, including recognition of limitations, and 2) explicit definition of the pilot-airplane task for the evaluation pilots. A valid simulation combined with meaningful assessment will indicate problem areas and help formulate methods for solution.

SECTION II SYSTEM CAPABILITY AND MECHANIZATION

The B-26 variable stability airplane (Figures 1, 2, 3, and 4) is able to simulate a wide range of aircraft statics and dynamics in flight. The way in which the capability has been applied to simulation of the large airplane in the approach configuration is described in the following subsections. Also included is a description of the inherent limitations to this capability. Airplane motion sign conventions used throughout this report are shown on Figure 5.

I. LONGITUDINAL

Simulation of the longitudinal mode is achieved by using a model-following technique, a method by which the simulator (B-26) is commanded to follow the output of an airborne analog computer, programmed with equations of motion representing the C-5A airplane. In this particular case, the incremental pitch angle output of the model ($\Delta\theta_m$) in response to airplane elevator and throttle inputs is compared with the $\Delta\theta$ of the airplane ($\Delta\theta_a$). The resulting difference, or error (ϵ_θ), is then used to drive the B-26 elevator to reduce the error to zero. Thus the incremental pitch angles of the model and airplane are matched and the B-26 will assume the model characteristics of the C-5A as represented by the computer. A sketch of this system is shown on Figure 6. Note that a Δq comparison loop is also employed, enabling higher loop gains (δ_e/ϵ_θ and δ_e/ϵ_q) and producing better $\Delta\theta$ following. Note also that the throttle input (δ_r) commands the model as well as the B-26, and in a ratio so as to approximately match the incremental longitudinal acceleration from the initial approach condition assumed.

In addition to matching the time response of $\Delta\theta$, and hence the dynamic modal characteristics (ω_{SP} , ζ_{SP} , ω_p and ζ_p), it is desirable to match the static stick force per incremental normal acceleration ($F_{ES}/\Delta n_z$), and stick force per unit stick travel (F_{ES}/δ_{ES}). The B-26 variable control feel system in conjunction with the model provides this capability. Stick force per incremental normal acceleration is defined as

$$\frac{F_{ES}}{\Delta n_z} = \frac{F_{ES}}{\delta_{ES}} \cdot \frac{\delta_{ES}}{\delta_e} \cdot \frac{\delta_e}{\Delta n_z} = \frac{F_{ES}}{\delta_{ES}} \cdot \frac{\delta_{ES}}{\Delta n_z}$$

In the present study, the B-26 was calibrated by in-flight measurement to have the same stick travel per incremental normal acceleration as the large airplane. The value of F_{ES}/δ_{ES} for the large airplane was set into the feel system, resulting in the required $F_{ES}/\Delta n_z$.

The airborne analog computer used in this study was designed and fabricated by CAL personnel (again note Figure 3).

2. LATERAL-DIRECTIONAL

Simulation of lateral-directional modal characteristics is accomplished by using the response-feedback technique. Electrical signals, proportional to sensed aircraft motions, are fed through gains (adjustable in the cockpit) to the appropriate surface actuator. The surface responds, producing a force and moment proportional to the aircraft motion. In its simplest form, this is equivalent to changing the inherent stability derivatives and thereby changing (or matching) the required dynamic characteristics, e. g., $N_{\dot{\delta}_r}^{\text{TOTAL}} = N_{\dot{\delta}_r}^{\text{AIRPLANE}} + N_{\dot{\delta}_r} \left(\frac{\delta_r}{\beta} \right)$. A simple diagram of such a system is shown on Figure 7.

Correct combinations of the feedback gains will provide the desired Dutch roll characteristics (ω_d , ζ_d , and $|\phi/\beta|_d$) and the roll mode time constant (τ_R). This is done by first estimating the gains on the basis of B-26 stability derivatives and the derivatives of the airplane to be simulated. However, final determination of these gains is based on flight calibrations wherein appropriate maneuvers are recorded and analyzed to obtain the desired simulated characteristics as a function of the feedback gains.

In addition to matching the lateral-directional modal characteristics, it is desirable to match control effectiveness, i. e., essentially the initial moment outputs due to control inputs. Ideally, one would like to match both the output due to control force input and the output due to control displacement input. To accomplish this, two adjustable gains must be available, one to vary the control column force versus control column displacement gradient (feel spring) and one to vary the control surface displacement versus control column displacement gradient (elevator gear ratio). In the B-26 lateral-directional variable stability system, only the former is readily available for aileron and rudder control. (Force displacement ratios can and have been approximately simulated by the installation of appropriate mechanical springs in the rudder and aileron control systems. This was done for this program.)

Assuming the availability of only the one electronic gain, either of the output-input ratios can be matched, but a choice must be made. Experience has shown that the pilot is more sensitive to forces than to displacements and therefore the gear ratio gain is used to match the moment output to force input. As an example of this matching process, consider $N'_{F_{RP}}$. (Primed notation is described in Appendix I.) It is required that $N'_{F_{RP}}|_{B-26} = N'_{F_{RP}}|_{\text{SIM. AIRPLANE}} = \frac{\dot{r}}{F_{RP}}$

for an F_{RP} step. This relationship may be developed in terms of the variable stability B-26 gain, δ_r/δ_{RP} :
$$\frac{\delta_r}{\delta_{RP}} = \frac{N'_{\dot{\delta}_r} \left(\frac{\delta_r}{F_{RP}} \right)_{\text{SIM. AIRPLANE}}}{N'_{\dot{\delta}_r} \left(\frac{\delta_{RP}}{F_{RP}} \right)_{B-26}}$$

With a knowledge of the relative airplane characteristics and the relationship between the δ_r/δ_{RP} cockpit gain setting and the physical δ_r/δ_{RP} , the desired matching can be obtained. Another way of doing the same thing is to compute the required $\dot{r}/F_{RP}|_{\text{SA}}$, and then for various δ_r/δ_{RP} gain settings, record the r responses to δ_{RP} inputs. The resulting measured ratios of \dot{r}/δ_{RP} when multiplied by the inverse of the B-26 rudder pedal spring, δ_{RP}/F_{RP} , yield values of \dot{r}/F_{RP} as a function of δ_r/δ_{RP} gains, from which the appropriate value of δ_r/δ_{RP} gain can be chosen to match the required \dot{r}/F_{RP} . Similar procedures are used to match $\dot{\phi}/F_{AS}$.

For this particular program, it was required to simulate

1. Three values of control power ($pb/2U$) for full aileron inputs,
2. Two values of aileron servo characteristics - chosen to bracket those typical of a large airplane.
3. Nonlinear roll control effectiveness. (The curves (C_L vs. δ_{AS}) for the C-5A airplane shown on Figure 8 were used.)

To do this, the following mechanization was employed:

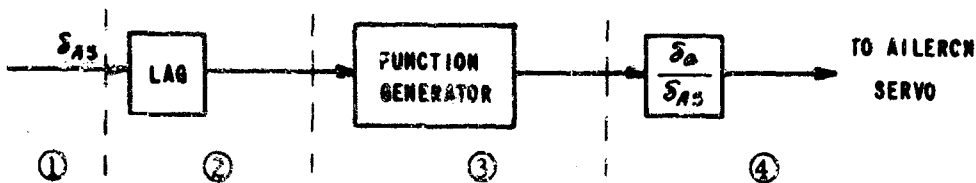

- ① Assume a δ_{AS} input (step, for example).
- ② "Lag" modifies δ_{AS} with a rate limit and assumed servo dynamics.
- ③ A different C_L vs. δ_{AS} is required for each $pb/2U$ simulated (see Figure 8). For a given $pb/2U$, the function generator is programmed to provide the required shape of δ_a as a function of δ_{AS} in order that the desired C_L is obtained.
- ④ The signal from ③ is varied by the gain δ_a / δ_{AS} to produce the required $pb/2U$ for maximum δ_{AS} input.

With this system, considering only the rate limit, the aileron will move at different rates to achieve the required $pb/2U$ in the same time.

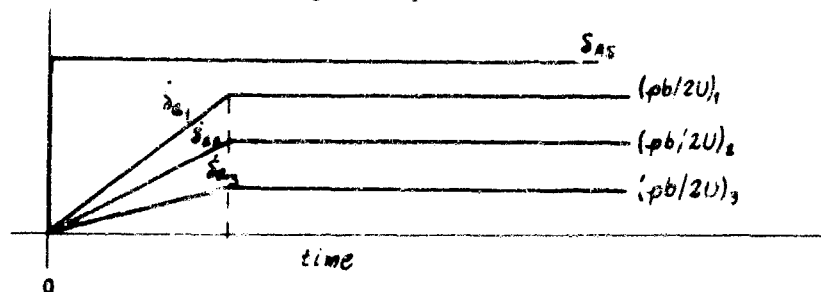

Specific quantitative details of the simulation are given in Section IV.

3. MISCELLANEOUS INSTALLATIONS

Several installations were made to improve the simulation and cockpit environment:

1. The normal B-26 airspeed indicator on the evaluation pilot's panel was replaced with a meter which displayed the model airspeed. Early in the pre-evaluation proof-flying phase of the program, it was noted that, in turns, the relationship of the B-26 airspeed with the airplane motions and stick position as commanded by the model was unrealistic. Displaying the

model airspeed produced the required correlation, subject to the limitation noted in the following subsection.

2. A block was installed on the control column to limit the aileron wheel travel to $\pm 60^\circ$.
3. The rudder pedal spring constant was altered to 60 lb/inch to more closely match the C-5A value of 50 lb/inch. The maximum rudder pedal travel was adjusted such that 150 pounds gave full deflection. This matches the simulated airplane value.

4. LIMITATIONS AND DIFFERENCES

"Simulation" of one vehicle by another implies differences between the two. The basic problem is to minimize these differences to a point where they will not affect the pilot's judgment when rating the pilot-airplane mission.

In general, a simulation of this type may be characterized by the following categories:

1. Aircraft static and dynamic characteristics.
2. Pilot environment; internal (cockpit) and external cues.
3. Prescribed mission simulation.
4. Undesirable or marginal side effects from attempting to satisfy the above.

As it is true that the present state of the art imposes certain practical limits on some phases of the simulation, it is also true that the evaluation pilot, in addition to having some "filtering" capability, also has a certain finite bandwidth of sensitivity, thus allowing some lack of simulation fidelity without affecting his rating.

Comparison with the results of previous studies has indicated that simulation of the large airplane static and dynamic characteristics as carried out in this program is well within the bandwidth of the pilot's ability to sense differences.

Pilot reports indicated that in general there was little in terms of internal or external cues to invalidate his rating of the configurations. However, minor exceptions to this rule, actual physical differences, and differences which were not obvious to the pilot are listed below.

1. The evaluation side of the cockpit (essentially normal B-26) contained an instrument panel which, although arranged for efficient observation, did not necessarily display instruments of a format projected for the simulated airplane. In particular a normal ILS cross-pointer meter provided glide slope and localizer information. Due to lack of information early in the program, it was decided to use this instrument rather than one of the more complex displays.
2. Without auxiliary direct lift and side force control, the derivatives L_z and Y_p cannot be matched, producing a difference

in turbulence response, the ramifications of which are discussed in the succeeding subsection.

3. It was noted in subsection 3 that the model airspeed was displayed in the evaluation side of the cockpit because of a significant difference between the model and B-26 airspeed in prolonged turning flight. However, despite this improvement, it was observed that upon entering a level turn at constant power, the model airspeed did not decrease as much as predicted. The difficulty was due to the fact that the pilot was flying by reference to the displayed B-26 h and k , which in turning flight differed from the model h and k . The difference in L_{α} causes the $\Delta\alpha$ required to sustain level flight to be greater in the case of the large airplane. Hence, since the θ 's are matched, the flight path (γ) of the large airplane is inclined downward in turns, when the B-26 flight path is level.
4. Thrust output to an abrupt throttle input occurs more quickly in the B-26 than in the simulated airplane. Generally, this difference is not serious because, except for rare occasions, throttle inputs are gradual rather than abrupt, resulting in similar thrust-to-throttle following.

5. TURBULENCE RESPONSE SIMULATION

In addition to control inputs, the B-26 simulation is subjected to external inputs such as turbulence and wind shear. Because these inputs have a definite effect on the pilot-airplane mission, it is of interest to compare the relative reactions of the B-26 simulator and the large airplane configuration.

The following remarks are somewhat qualitative, but do indicate the factors involved and their relevance to the subject simulation program. They are based on the simple concept of a gust velocity vector which can be reduced to longitudinal, vertical and lateral components which act as inputs to the airplane.

Considering first the longitudinal mode, a vertical gust component (w_g) is equivalent to an angle of attack change, which causes both a heaving or vertical motion and a pitching motion about the airplane's center of gravity. The sensitivity of the airplane to the vertical component is defined in Reference 5 as follows:

$$\left| \frac{n_z}{-g} \right|_{ss} = \frac{C_{L_{\alpha}} \rho V}{2 \frac{W}{S}} = \frac{L_{\alpha}}{g}$$

where $|n_z/w_g|_{ss}$ is the steady-state portion of the n_z/w_g transfer function.

Thus one comparison of gust response can be made between the L_{α}/g of the B-26 and that of the airplane being simulated. In the subject case, the ratio of $(L_{\alpha}/g)_{B-26}$ to that of the simulated airplane is approximately 1.9. Hence, the response of the B-26 is greater than that of the large airplane.

When the B-26 pitches due to a gust input, there is a difference between the θ of the airplane and that of the model, because the model does not sense the gust input. This error, ϵ_θ , will actuate the elevator of the B-26 and tend to reduce the pitching motion to zero. Thus the airplane is operating in essentially an "attitude hold" mode and pitch deviations from the initial attitude will be minimal. The large airplane on the other hand, if left alone would pitch to a new steady-state θ commensurate with the gust angle of attack change. However, because of the low short-period frequency of the large airplane, the pitch response to the gust will take a relatively long time to occur. Since the heave response will be felt immediately, it is likely that little pitch deviation will occur before the pilot initiates a corrective control input. Thus, although the pilot's response to vertical gusts is different between the simulated and simulator airplanes, it is believed that the difference would not significantly affect the evaluation results reported here...

The lateral gust component input is somewhat analogous to the longitudinal gust input in that it is equivalent to sideslip angle change. If the force and moment derivatives were perfectly matched and the gust affected the airplane and its feedback sensors in exactly the same manner, then the gust response would be the same as that of the simulated large airplane.

However, the feedback gains used were not based on exactly matching each derivative, but rather on matching the required modal characteristics and pertinent time histories. The inability to match Y_β because of lack of auxiliary side force control means that other derivatives must be slightly mismatched. Because Y_β predominantly affects Dutch roll damping, this mismatch can be largely accounted for through introduction of N_β to match the damping. However, the introduction of N_β itself, a derivative not inherent in an unaugmented airplane, will cause the B-26 to respond directionally to lateral gusts more than the simulated airplane would.

Probably the most significant difference in lateral gust response between the two airplanes is in the w_y/β steady-state amplitude, which is a function of the Y_β and V mismatch. In this case, the w_y/β of the B-26 is approximately 1.5 times greater than that of the simulated airplane.

In summary, it may be noted that the heave response of the B-26 in turbulence is greater than the simulated airplane. Thus in those cases where turbulence is judged to be a significant factor, the pilot objections to the turbulence responses in the B-26 would be more severe than in the simulated airplane. In this study, however, the majority of configurations were flown under smooth air or light turbulence conditions and this difference is not believed to have a significant effect on the evaluation results.

SECTION III PRELIMINARY ANALYSIS

Prior to mechanization of the unaugmented and augmented longitudinal models and to flight calibration of the lateral-directional simulated configurations, a considerable amount of analysis was accomplished which is pertinent to defining the method of approach used in this study.

The mass, geometric and nondimensional stability data furnished by Lockheed-Georgia was converted to appropriate coefficients consistent with the equations of motion given in Appendix I. These equations were solved by a digital computer to obtain modal characteristics and time history responses to classic control inputs (elevator, aileron and rudder steps and doublets). The modal characteristics were then compared with those furnished by Lockheed and these and the responses were used as the basic foundation for validation of the in-flight simulation.

The basic longitudinal data was specified by Lockheed and assumed for the unaugmented airplane. The augmented configuration was formulated at Lockheed's request by assuming an increase in short-period frequency from approximately .15 Hz (unaugmented case) to .17 Hz and a decrease in short-period damping ratio from .73 (unaugmented case) to .6. Using the short-period approximate equations for frequency and damping, new values of $C_{m\dot{\alpha}}$ and $C_{m\ddot{\alpha}}$ were determined for the above required f_{sp} and ζ_{sp} . Other derivatives were maintained constant. The new values of $C_{m\dot{\alpha}}$ and $C_{m\ddot{\alpha}}$ were then applied to the three-degree-of-freedom equations of motion for digital solution. The model characteristics compared favorably with those assumed in the approximation and no iteration was required.

In the lateral-directional case, the furnished data were also for the unaugmented configuration, and the augmented configuration was formulated on the basis of an augmentation scheme furnished by Lockheed. This scheme fed β , ϕ , and ψ to the rudder and ϕ to the aileron. Incremental artificial derivatives due to these feedbacks were added to those of the unaugmented configuration. The resulting data were fed to the digital computer, producing new modal characteristics and time history responses. These were then used as the basis for simulation of the augmented configuration.

Since the pitch simulation incorporated a model-following system, it was necessary that the model include significant lateral-directional coupling terms in order that the longitudinal simulation be correct in turning flight. Two terms are important. The first involves the computation of the Euler angle θ_w , including the term $r \sin \phi$:

$$\theta_w = \int (q_w - r \sin \phi) dt$$

Additional terms in the Euler angle computation were considered negligible for this simulation.

The second item is the term $\frac{g}{V} \cos \phi$ in the \dot{z} equation:

$$\begin{aligned} \Sigma \text{ FORCES } \zeta &= \zeta_u \Delta u + \zeta_{\dot{u}} \Delta \dot{u}_m + \zeta_{\delta_c} \delta_c + \zeta_v \Delta v_m + \zeta_{\theta} \Delta \theta_m + \zeta_q q_m + \frac{g}{V} \cos \phi \\ &= \frac{g}{V} n_z \end{aligned}$$

If the above terms are not included, the computed θ_m will be in error in turning flight. The model-following system will force θ_m to follow θ_m and an incorrect airplane response will result. For example, without the terms above, the airplane (if trimmed in steady level flight) will require no back pressure on the yoke in level turns. Although possibly an interesting characteristic, this feature would not provide realistic simulation of the large airplane.

It was felt desirable to simulate the nonlinear variation of rolling moment coefficient with aileron wheel, based on the data submitted by Lockheed. These data consist of $C_{l\delta_A}$, $C_{l\delta_S}$ versus spoiler deflection for the three pb/2U values investigated, and curves of aileron and spoiler deflection versus wheel deflection. The shape of these curves is shown on Figure 8, where each is normalized to the maximum pb/2U ($\delta_{AS} = 60^\circ$) investigated. Flight test data for each are also shown and again normalized to show correspondence to the desired shape resulting from the use of a function generator. The end points of $\delta_{AS} = 60^\circ$ were calibrated to produce the desired pb/2U for full wheel deflection by variation of the gain δ_a/δ_{AS} .

The total yawing moment coefficient as a function of δ_{AS} (including effect of aileron and spoiler) was formulated in the same way as the rolling moment. However, in this case a linear approximation with δ_{AS} was used rather than a function generator, resulting in the $N'_{\delta_{AS}}$ derivatives defined in Appendix I.

SECTION IV CONFIGURATION SIMULATION

This section details the extent and degree of large airplane simulation attained with the B-26 variable stability airplane. The overall simulation program is shown on Figure 9.

As previously noted, it was desired to simulate the longitudinal short period characteristics, ω_{sp} and ζ_{sp} , and the lateral-directional characteristics, T_d , ξ_d , $|\theta/\delta|_d$ and ζ_ϕ for the unaugmented and augmented C-5A configurations. The longitudinal unaugmented configurations were defined by stability derivatives, speed, mass and inertia characteristics estimated for the C-5A airplane by Lockheed-Georgia. As noted in the previous section, the longitudinal augmented configuration was defined by Lockheed in terms of ω_{sp} and ζ_{sp} only.

The parametric variables $pb/2U$ and F_{ss}/An_2 were also defined by Lockheed; the aileron control lags were defined by both Lockheed and CAL.

The following table gives a comparison between the large-airplane characteristics and the B-26 simulated characteristics. This table includes other characteristics in addition to those mentioned above.

The extent of matching longitudinal characteristics is shown in Figures 10 through 17. The pitch response of the model is shown for step and random elevator and throttle inputs for both the unaugmented and augmented configurations. Also shown is the error in pitch for the same conditions, defined as $\epsilon_\theta = \theta_w - \theta_a$. These data were obtained by in-flight measurement. In addition, Figures 13 and 14 show digital solutions of the equations of motion used to verify the mechanization of the model analog. Figures 16 and 17 show initial portions of the θ , $\dot{\theta}$, and $\ddot{\theta}$ responses to step elevator commands (in-flight measurements).

LARGE AIRPLANE	SIMULATED
Longitudinal (Model-Following)	
Dynamic	
Unaugmented	
$\omega_{sp} = .9452$ rad/sec	= .915 rad/sec
$\zeta_{sp} = .731$	= .719
$\omega_{sp} = .1995$ rad/sec	= .1924 rad/sec
$\zeta_{sp} = .1034$	= .105
Augmented	
$\omega_{sp} = 1.06$ rad/sec	= 1.08 rad/sec
$\zeta_{sp} = .6$	= .606
ω_{sp} not specified	= .214 rad/sec
ζ_{sp} not specified	= .085

LARGE AIRPLANE

SIMULATED

Longitudinal

Static (same for both unaugmented and augmented cases):

1. * $F_{RS}/\Delta\alpha_T = 106.45 \text{ lb/g}$	= 106 lb/g
$F_{RS}/\delta_{RS} = 5 \text{ lb/in.}$	= 5-6 lb/in.
2. * $F_{RS}/\Delta\alpha_T = 158 \text{ lb/g}$	= 158 lb/g
$F_{RS}/\delta_{RS} = 7.5 \text{ lb/in.}$	= 8-9 lb/in.

Lateral-Directional

Dynamic

Unaugmented

$\tau_R = 1.12$	= .90-1.20
$\omega_d = .488$	= .500-.540
$\zeta_d = .266$	= .22-.28
$ \phi/\beta = .9185$	= .8-1.1

Augmented

$\tau_R = 1.00$	= .90-1.20
$\omega_d = .440$	= .484-.57
$\zeta_d = .539$	= .5-.57
$ \phi/\beta = .945$	= .8-1.1

Static

$F_{RS}/\delta_{RS} = .35 \text{ lb/deg}$	= .43 lb/deg
$F_{RP}/\delta_{RP} = 50 \text{ lb/in.}$	= 60 lb/in.
$F_{RP_{max}} = 150 \text{ lb}$	= 150 lb
$\delta_{RS_{max}} = 60 \text{ deg}$	= 60 deg
$\delta_{RP_{max}} = 3 \text{ in.}$	= 2.5 in.

The B-26 was calibrated for the following values of pb/2U for full wheel deflection of 60°. Associated values of bank angle occurring one second after initiation of the wheel input are noted for the two control wheel lags (also see Figure 18).

* C-5A values include 12.85 lb/g bobweight effect. This is included in the B-26 simulation by slightly increasing F_{RS}/δ_{RS} .

pb/2U (1/rad)	ϕ_1 (deg)			
	Lag 1		Lag 2	
	Unaug.	Aug.	Unaug.	Aug.
.10	2	5	1.3	2.9
.17	3.5	7.9	2.3	4.5
.25	5.5	10.9	3.9	6.0
.32	8.2	---	---	---

The aileron control lags are specified in terms of time required to apply full control moment. (Regardless of the method by which it is done, the B-26 must of course use its ailerons; the simulated airplane uses a combination of aileron and spoilers.) Lag 1 is the normal B-26 aileron lag, with essentially no dwell time and a rate limit which provides full control in approximately .4 seconds. Lag 2 was electronically mechanized to provide a .1-second dwell time and a rate limit to accomplish full control in .9 seconds (see sketch below).

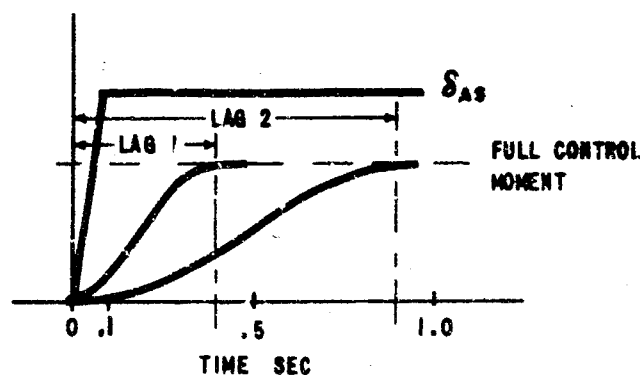

Of primary interest was the matching of yaw rate response to rolling moment control input. Previous work (Reference 1) had indicated that lack of turn coordination (the airplane banks but does not turn) had a profound effect on pilot acceptability. This characteristic was quite noticeable from the digital δ_{AS} step responses using the C-5A data. The extent of this matching (for small inputs) is noted for a typical case on Figures 19 and 20. In order to match the r time history it was necessary to sustain a slight mismatch in the roll rate time history. While on the whole this mismatch does not appear significant, it may be noted that ϕ_1 is different for the augmented and unaugmented cases.

The result is that for the same maximum pb/2U attainable at 60° and for the same lag, the ϕ_1 for the augmented case will be greater than that for the unaugmented case.

SECTION V EVALUATION TASK AND PROCEDURES

The evaluation task was designed to facilitate investigation of all phases of the approach maneuver with the exception of the flare to touchdown. Evaluation of a given configuration was based on three phases.

First, airwork maneuvers were performed by the evaluation pilot VFR and under the hood. The purpose of this was to allow the pilot to become familiar with the configuration and in particular enable him to ascertain the maximum control capability available. During the approach maneuver itself, small control inputs are normally used except in those cases where the airplane is upset by gusts or for some reason allowed to stray far from the desired path. A prior knowledge of his ability to return to the desired path helps the pilot determine his control technique on the basis of any limitations present.

Secondly, two simulated ILS approaches were made, initiated by capture of the localizer from beyond the outer marker followed by beam tracking to the flare point. On one of these, the pilot would purposely get off the glide slope and localizer (one or two dots) to see how easily he could return.

The third phase consisted of a simulated cloud breakout maneuver (two for each configuration), performed in the following manner (Figure 21). The safety pilot positioned the airplane approximately 200 feet to the side of the localizer course, and turned over control of the airplane to the evaluation pilot just outside the middle marker. The evaluation pilot held the airplane attitude constant as it was given to him until a 200-foot altitude was reached. He then came out from under the hood and maneuvered the airplane back to the runway visually, requiring both longitudinal and lateral corrections.

The evaluation pilot was made aware that he was not time-limited and no pressure was placed on him to complete either his maneuvers or comments in a given time.

Pilot comments were wire recorded in response to the comment guide shown on the following pages. In addition, he was encouraged to make additional comments as he desired. Comments on the airwork phase were made immediately. Comments on the ILS and breakout maneuvers were usually made in a group following completion of all the approaches and before beginning the next configuration. A numerical rating was assigned after completion of the comments prior to commencing the next configuration. The CAL rating scale is shown on page 16. A detailed explanation of the use of this rating scale is given in Reference 6. This reference was read by all pilots before performing the evaluation, and additional briefings were given to ensure understanding of the system. Reference 7 is an attempt to combine certain concepts of the Cooper and CAL rating systems to define a single improved scale and in particular to enlarge upon some of the simple descriptions of the CAL scale which to some pilots have not been particularly helpful. Copies of this report were given to the three evaluation pilots after the evaluation (the report has just been published) for them to determine if, on the basis of the more lucid descriptions, they would have evaluated the configurations differently. Although there was indication that the revised system would be more helpful, the pilots felt their ratings would have been the same had the revised scale been used.

PILOT COMMENT GUIDE

I. Airwork

A. Longitudinal

1. Ease and precision of making small pitch corrections - technique used - tendency to PIO?
2. Does the airplane stay at a given pitch angle and airspeed?
3. Is the trim well defined? Sensitivity? Does longitudinal response affect ability to locate trim?
4. Comment on longitudinal control during turn entries, steady turns and level flight recoveries.
5. Force level, gradient, and friction suitability.
6. Stick travel suitability.
7. Ability to change and maintain altitude.
8. Turbulence level.
 - a) light
 - b) moderate
 - c) heavy.

B. Lateral-Directional

1. Heading control and ease of initiating and stopping turns on desired heading - technique used.
2. Bank angle control; ability to start and stop and maintain constant bank angle.
 - a) ability to pick up a wing
 - b) roll authority suitability
 - c) time from input to full output
 - d) time from input to beginning of output
 - e) tendency to overshoot and oscillate
 - f) type and relative amount of control used.
3. Instruments used most of the time.
4. Turbulence level
 - a) light
 - b) moderate
 - c) heavy.

II. Long Glide Slope Maneuver (IFR)

A. Ability to capture ILS beam.

1. Localizer.
2. Glide slope.

B. Ability to track ILS beam (ability to make small corrections).

1. Localizer.
2. Glide slope.
3. Airspeed control.

PILOT COMMENT GUIDE (CONTINUED)

II. Long Glide Slope Maneuver (IFR) (continued)

- C. Control technique used (relative amounts of elevator, throttle, aileron and rudder).
 - 1. Localizer.
 - 2. Glide slope.
 - 3. Airspeed.
- D. Workload.
Excessive?
- E. Oscillation in
 - 1. Altitude?
 - 2. Attitude?
 - 3. Heading?
 - 4. How do you stop oscillation?
- F. Turbulence level.
 - 1. light.
 - 2. moderate.
 - 3. heavy.
- G. Of all the above considerations (A through E), which gave the most difficulty, and how well were you able to complete the mission?
- H. Did any single or group of difficulties become more difficult when trying to correct another?

III. Breakout Maneuver

- A. Ease of approach maneuver from the 200-foot altitude mark.
 - 1. Laterally - lining up with runway.
 - 2. Longitudinally - maintaining proper rate of descent.
 - 3. Aileron control power sufficient?
 - 4. Rudder control power sufficient?
 - 5. Of all the above considerations, which gave the most difficulty and how well were you able to complete the mission?
- B. Turbulence level.
 - 1. light.
 - 2. moderate.
 - 3. heavy.

GENERAL:

- 1. Control harmony?
- 2. Rudder coordination requirement?
 - a) turn entries, steady turns and recoveries.
 - b) precision of rudder control.
- 3. Pitching moments due to power.

PILOT RATING SCALE

Category	Adjective description within category	Numerical Rating
Acceptable and Satisfactory	Excellent	1
	Good	2
	Fair	3
Acceptable but Unsatisfactory	Fair	4
	Poor	5
	Bad	6
Unacceptable	Bad*	7
	Very Bad**	8
	Dangerous†	9
Unflyable	Unflyable	10

- * requires major portion of pilot's attention
- ** controllable only with a minimum of cockpit duties
- † aircraft just controllable with complete attention.

SECTION VI DISCUSSION

1. GENERAL

Longitudinally, evaluation of the large airplane was dominated by characteristics associated with large ratios of inertia to aerodynamic force - basically slow responses which appeared to the pilot to be very loosely associated with control inputs. The slow pitch response combined with large stick travel required to produce the desired motion was generally manifested by an inability to make precision pitch changes which became more marginal as the task became more demanding. A tendency to overshoot a desired change by overdriving the airplane and either producing a pilot-induced oscillation or being on the verge of producing one was characteristic in many cases.

From a lateral-directional viewpoint, the evaluation was dominated by lack of turn coordination, i.e., the reluctance of the airplane to turn when banked, using aileron control alone. The necessity for using rudder in a correct fashion to initiate the turn increased the workload and detracted from the ability to make both large and small lateral flight path changes.

There was considerable interdependence between the longitudinal and lateral-directional characteristics. The necessity for concentration on precise control of one mode reduced the effectiveness of control in the other.

The general characteristics noted above tended to put the airplane in a category no better than "acceptable but unsatisfactory", regardless of the variation of other parameters.

2. LONGITUDINAL

Pilot comments indicate generally that the elevator stick travel per unit airplane response was too large. The stick motion that was used in the evaluation was a proposed characteristic of the C-5A airplane. This relatively large stick motion resulted from Lockheed ground simulator tests which considered the compromises necessary in their flight control system between high- and low-speed flight conditions. Pilot A in particular felt that this was one of the poorer characteristics of the configurations, describing the stick travel as "highly unsuitable." Pilot B appeared to be less sensitive to this characteristic and while conceding that the travel was a "bit more than desired" and "a little too much," termed it "satisfactory" and "acceptable." Pilot C reflected an attitude similar to that of Pilot A, describing the stick travel as "not suitable," and "uncomfortable." His primary concern was that in some cases he had difficulty in maintaining altitude during 30 degree banked turns.

The above comments refer to all the longitudinal configurations except the fully augmented case with the higher $F_{ES}/\Delta n_z$ of 158 lb/g. Here the stick travel appeared to be slightly more suitable to all three pilots.

Stick travel per incremental normal acceleration was approximately the same for all configurations and was calibrated to match the C-5A data, resulting in approximately 20 inches per g.

The following comments refer to Figures 22 through 27.

The general numerical rating variation of one half unit with change in $F_{G5}/\Delta n_z$ indicates a relatively insignificant effect on performance of the mission. Pilot A's comments, however, do show a distinct and varied preference for the higher $F_{G5}/\Delta n_z$ (158 lb/g). Pilot B and Pilot C felt this to be a bit high.

The general numerical rating variation of from one to three units indicates a significant effect of longitudinal augmentation as it was applied in this study. Although the changes in short-period frequency and damping from the unaugmented to the augmented case do not appear significant in themselves, analysis of the time histories of the two models shows the initial $\dot{\theta}$ response to elevator stick input to be approximately twice as large for the augmented configuration as for the unaugmented configuration. Pilot comments indicate a greater ability to make pitch corrections with the larger $\dot{\theta}$. Lateral-directional augmentation was on during the above comparison.

When the unaugmented lateral-directional configuration was combined with the unaugmented longitudinal configuration, the average ratings of Pilots B and C decreased up to one rating from the lateral-directional augmentation on, longitudinal augmentation off case. Pilot A showed an improved rating of one unit above the noted reference. Comment data did not reveal any significant reason for this inconsistency with Pilots B and C.

The above is based on ratings of the complete pilot-airplane mission as a whole, thus including the base lateral-directional characteristics, as well as the variation of longitudinal characteristics. Pilot B was asked to rate the airplane considering only its longitudinal characteristics (neglecting any lateral-directional deficiencies). Limited data indicates that when evaluation is made on this basis only, the airplane is from one-half to one and one-half ratings better than when evaluated on an overall basis.

3. LATERAL-DIRECTIONAL

Aside from the differences in modal characteristics and $\dot{\theta}$ variation, noted earlier in this report, there are two other differences in the pilot comments. In the augmented case there is:

1. slightly better turning capability with ailerons alone, and
2. slightly better harmony between initial and final roll response.

Pilot A appeared to be particularly sensitive to differences in the unaugmented and augmented configurations, regardless of $\dot{\theta}$, and pb/2U (Figures 28 and 29). For the augmented case, his numerical ratings show the airplane to be in the low "acceptable and satisfactory" category from a pb/2U of .1 to .25 and a $\dot{\theta}$ of from 3 to 11 degrees. Ratings for the unaugmented case are substantially inferior, ranging from the middle of the acceptable but unsatisfactory category to the better portion of the unacceptable category. This difference was largely substantiated by his comments. In most cases, he had better heading and bank angle control in the augmented case. The workload was less in the augmented case due to the less complex use of rudder required, less frequent use of instruments and less tendency to excite and overshoot in

roll and yaw. Better harmony between initial and final roll response was noted, as was reduced coupling between longitudinal and lateral-directional motions.

Though not indicated generally in the numerical ratings (the unaugmented, lag 1 case is the exception), Pilot A felt that the low value of $pb/2U$ might be marginal. The middle value (.17) was most desired, the high values (.25 and .32) resulted in too much disharmony with respect to the large amounts of rudder pedal and elevator motion required to perform the maneuvers.

Differences between the unaugmented and augmented configurations were not as distinct with Pilot B as with Pilot A. Figures 30 and 31 show considerable scatter of data generally within the "acceptable but unsatisfactory" boundaries. However, similar trends are indicated between the two pilots at the low values of $pb/2U$ where the rating is better for the augmented case. Pilot B was conscious of slightly better heading control in the augmented case but not to the extent of Pilot A. Comments also indicate the tendency to overshoot and oscillate in roll characteristic of the slower initial roll response of the unaugmented configurations.

Comments leave some doubt as to whether or not the middle value of $pb/2U$ (.17) was sufficiently high. However, ratings show a tendency to peak at this value for the unaugmented case.

Though the comments of Pilot C were similar to those of the other two for a given configuration, he rated the airplane poorer, particularly at low values of $pb/2U$ and ϕ . In general, a stronger trend of greater acceptability with increase in ϕ and $pb/2U$ is noted (Figures 32 and 33).

As with the other two pilots, he observed better heading control and less tendency to overshoot and oscillate in roll in the augmented case than in the unaugmented case.

Figures 34 and 35 show the variation of pilot ratings with ϕ for constant $pb/2U$ (this is essentially a comparison of lag 1 and lag 2 for each case). Generally speaking, higher values of ϕ (lag 1) are desired for constant values of $pb/2U$ for both the augmented and unaugmented cases. For the two larger values of $pb/2U$ of the augmented case, only Pilot A shows decreased acceptability of ϕ greater than 4.5 degrees. Also, it may be noted that the majority of roll characteristic ratings fell below the upper boundary of the "acceptable but unsatisfactory" category.

The majority of the configurations were evaluated in smooth air or light turbulence. In those isolated cases where turbulence was greater, some degradation in performance was noted. However, there are insufficient data to support a specific trend.

SECTION VII CONCLUSIONS

LONGITUDINAL EVALUATION:

1. The majority of all pilot evaluation data, regardless of the presence or absence of augmentation or the tested values of stick force per g, fell in the "acceptable but unsatisfactory" category. By definition of the CAL rating scale, this means that the pilot's objections to the configuration characteristics are serious enough for him to request that something be done to improve them. If, however, this improvement cannot be made without serious compromise of other factors influencing the mission, the pilot will accept the airplane, but with reluctance.
2. On the basis of average numerical rating data, the effect of the specified augmentation was to improve the handling qualities of the airplane. Pilot's comments indicate the primary reason for this was the less sluggish pitch angle response in the augmented case. This increased the ability of the pilot to make small pitch corrections and to a degree diminished the amount of prediction required to accurately control the airplane.
3. On the basis of the three-pilot sample as a whole, there is little conclusive evidence as to the relative desirability of the two stick forces per g evaluated. Of the three, Pilot A most clearly indicated the desirability of the higher value (158 lb/g), particularly in the unaugmented case. Pilot B felt that this value was a bit high, but acceptable; Pilot C preferred the low value of 106 lb/g.
4. Stick travel per airplane motion, as defined by stick motion per incremental acceleration with a value of approximately 20 inches per g, appeared to be too high.

LATERAL-DIRECTIONAL EVALUATION:

1. As previously noted, the evaluation results were strongly influenced by lack of turn coordination using aileron control alone. Precision of lateral-directional control depended upon development and use of a combined rudder-aileron technique. The consistency (or lack thereof) of their success or failure with this technique, combined with severe lack of control harmony where large rudder motions were used, helped shape some of the varied opinions among the pilots as indicated by scatter of numerical rating data.
2. The aforementioned lack of turn coordination is not conducive to good lateral-directional control, a condition which is further amplified by the lack of control harmony it helps emphasize, particularly at the higher values of pb/2U.

3. Consistent reference by the evaluation pilots to differences between initial and final roll response give some indication that the slope of the roll response curve is important, at least up to the time maximum roll rate is achieved. This shape can assume different forms (as compared with the simplified first-order roll response defined by τ_R) depending upon the extent of nonlinear control characteristics and/or roll coupling. The curve which has the most consistent time rate of change of rolling velocity (i.e., $\dot{\phi}$ vs. time nearly constant) is the most desirable. One in which the initial $\dot{\phi}$ is less than the final $\dot{\phi}$ results in undesirable control characteristics similar to those of the generally sluggish airplane; and initial overdriving followed by overshooting and possible oscillation.
4. The simulation of a dwell time of .1 sec (time between initiation of aileron control wheel and response of the control surface), characteristic of aileron servo dynamics, had no apparent effect other than that associated with its contribution to a lower ϕ_1 .
5. In general, each pilot produced somewhat different results regarding the required roll power for the large-airplane landing approach, with Pilot C showing the strongest trend toward the higher roll power. The lower roll power ($pb/2U = .10$) was the least acceptable when combined with the unaugmented characteristics and low ϕ_1 . For Pilots A and B, the middle value of .17 appeared to represent a minimum $pb/2U$ independent of augmentation. For the same two pilots there appeared to be little change in rating toward the higher value, showing a slight degradation through .25 to the single test point of .32. Pilot C showed a continual desire for more power up to .25 after which there was a decrease to .32. It would appear that a $pb/2U$ of from .2 to .25 would be sufficient assuming it was associated with a suitable curve of ϕ vs. time. If the ϕ time response is too lacking in harmony, then $pb/2U$ becomes a less meaningful criterion.
6. For the unaugmented configuration and the low value of $pb/2U$ for the augmented configuration, there is a significant increase in acceptability with increase in ϕ_1 for constant $pb/2U$. This trend continues at the two higher $pb/2U$'s for the augmented case only for Pilot B. The other two show either a reversal or insignificant change from a value of 4.5° upward. There is insufficient data from which to specify a minimum ϕ_1 for an airplane with characteristics of the unaugmented configuration. For the augmented configuration, however, it appears that a ϕ_1 which is never below 4 to 5 degrees for any aircraft loading or speed may be sufficient.

SECTION VIII RECOMMENDATIONS

Calibration of the B-26 airplane for the large-airplane lateral-directional characteristics consumed a disproportionate amount of time in terms of both in-flight data recording and ground data reduction. A reasonable amount of in-flight calibration is characteristic of the response-feedback method of simulation. However, in the case where the airplane to be simulated has characteristics wherein it is required to provide an artificial stability increment nearly as large as that of the B-26, but opposite in sign (e.g., the simulated airplane has low static stability), accuracy is difficult to attain and a corresponding increase in the number of calibration data points is needed. This has been shown in the past to be the case for the longitudinal characteristics of the large airplane, leading to the use of the model-following technique as a more efficient way of simulation under these circumstances. Therefore, it is recommended that succeeding simulations of large-airplane lateral-directional characteristics be accomplished using the model-following technique.

The following recommendations are based on results of an in-flight evaluation of the configurations simulated in this study and do not necessarily pertain to the present C-5A airplane. They suggest areas of design improvement which, if carried out, would result in an airplane better able to perform the approach task, including both tracking and abrupt flight path alteration.

1. Reduce the elevator stick travel required to maneuver the airplane.
2. Increase the pitch acceleration capability of the airplane in response to an elevator input.
3. Increase the capability of the airplane to turn when banked using ailerons alone.

The remaining recommendations, although not necessarily independent of the above, are directed primarily toward expanded knowledge of handling qualities requirements.

4. Re-examine the effect of stick force per incremental normal acceleration in light of improved longitudinal dynamics.
5. Re-examine the effect of $pb/2U$ in light of improvement obtained from 4. above.
6. Generally expand the investigation of roll requirements in terms of $pb/2U$, Φ , nonlinear roll response, and other possible parameters to improve upon existing criteria.

REFERENCES

1. Newell, F. D.; Parrag, M. L. E., Bull, G.: Simulated Landing Approaches of an Unaugmented C-5A Configuration. CAL Report No. TB-2071-F-2, October 1965.
2. Rhoads, D. W.; Eckhart, F. F.: In-Flight Simulation of Low Speed and Cruise Handling Qualities of a Supersonic Transport Airplane. CAL Report No. TB-1992-F-1, October 1965.
3. Rhoads, D. W.: In-Flight Simulation and Pilot Evaluation of the Landing Approach Flying Qualities of a Supersonic Transport Airplane. CAL Report No. TM-2091-F-1, January 1966.
4. Lockheed-Georgia data sets, dated 5 January 1966, 23 February 1966, 15 April 1966, and 22 April 1966.
5. Notess, Charles B.: A Triangle - Flexible Airplanes, Gusts, Crews. CAL FDM No. 343, May 1963.
6. Harper, R. P., Jr.: Simulation and the Pilot. Paper presented at the AIAA Simulation for Aerospace Flight Conference, August 1963, Columbus, Ohio.
7. Harper, R. P., Jr.; Cooper, G. E.: A Revised Pilot Rating Scale for the Evaluation of Handling Qualities. CAL Report No. 153, December 1966.



Figure 1 B-26 THREE-AXIS VARIABLE STABILITY AIRPLANE

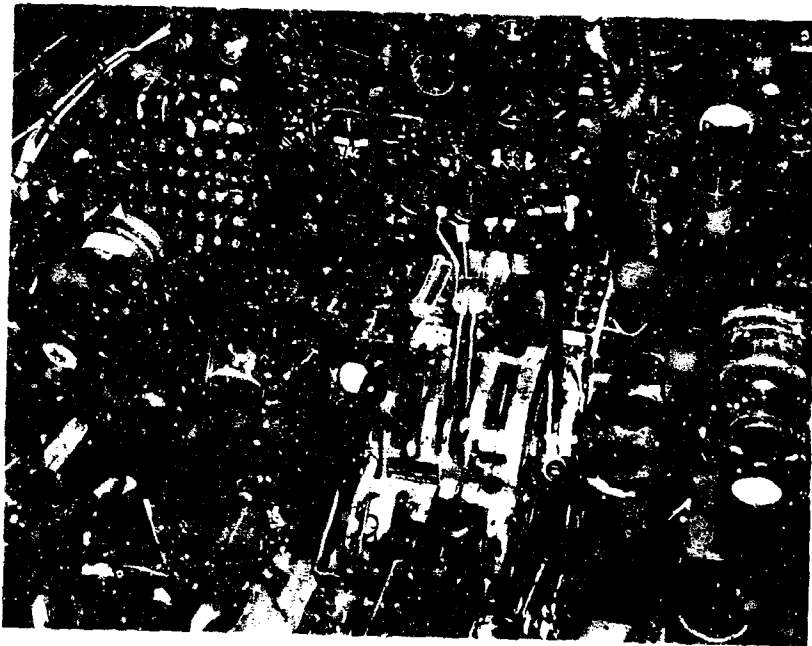

Figure 2 B-26 COCKPIT, SAFETY PILOT'S POSITION ON LEFT,
EVALUATION PILOT'S POSITION ON RIGHT

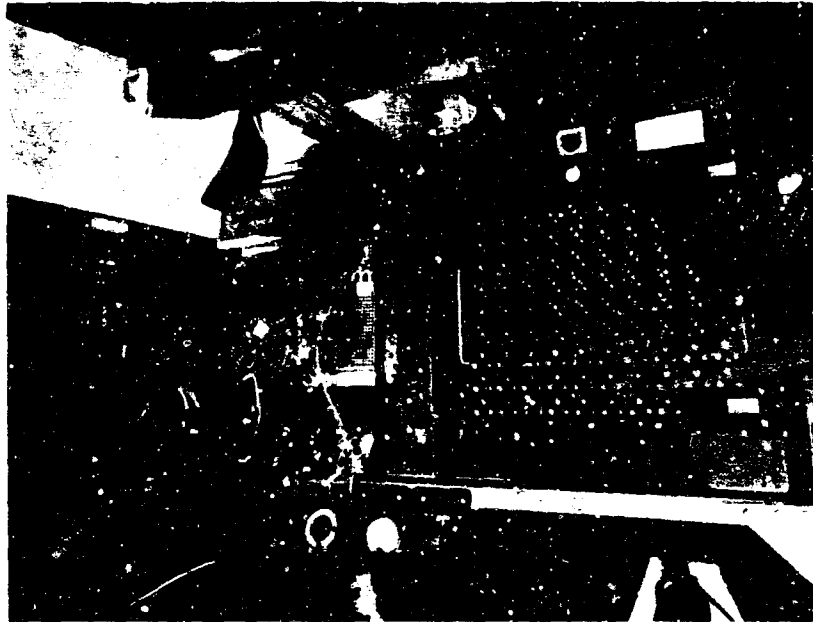

Figure 3 COMPUTER (MODEL) INSTALLATION IN B-26 WAIST COMPARTMENT, LOOKING FORWARD



Figure 4 VARIABLE STABILITY INSTALLATION IN B-26 BOMB BAY, LOOKING FORWARD

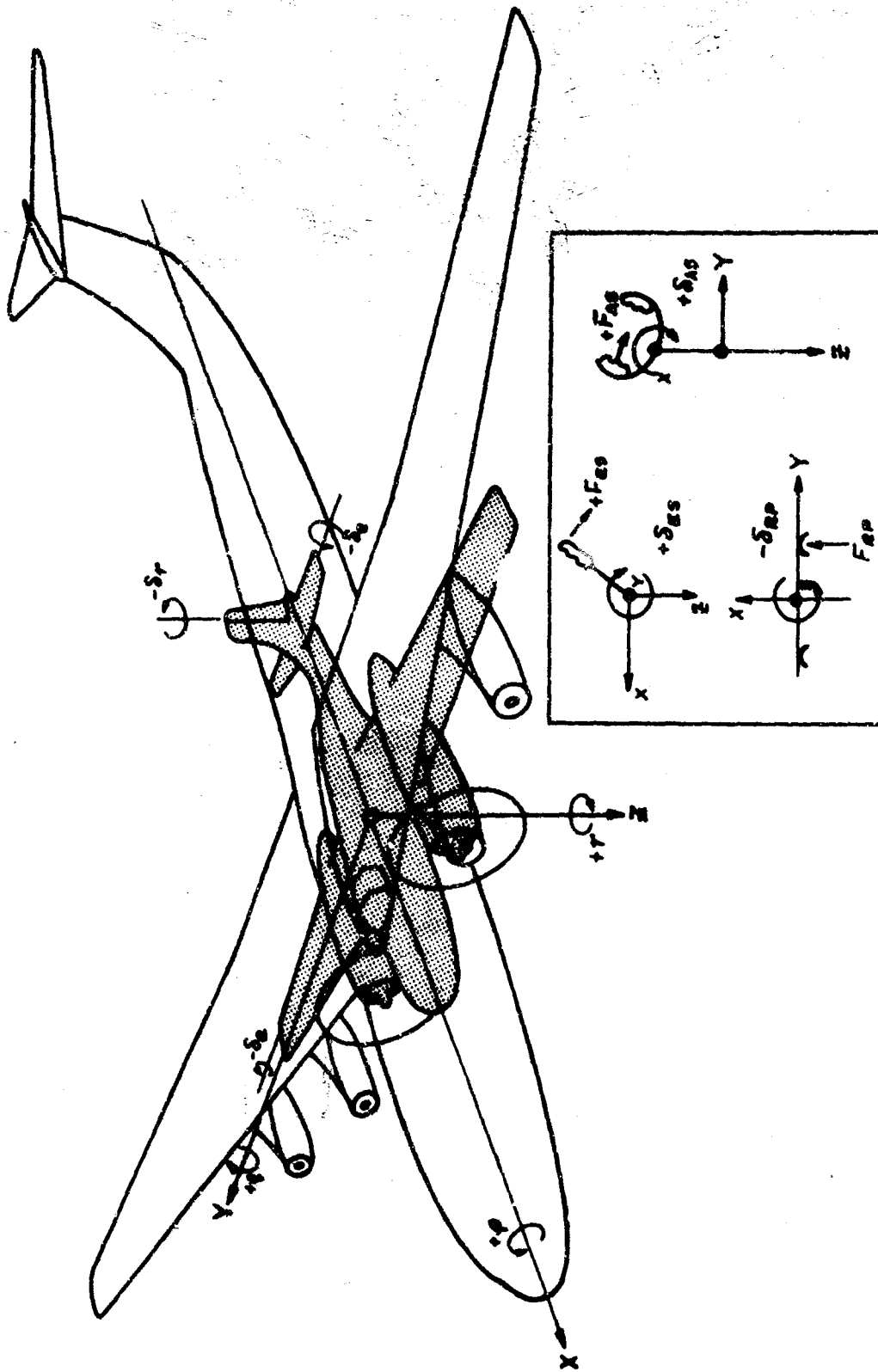

Figure 5 AIRCRAFT MOTION SIGN CONVENTIONS; RESPONSE TO POSITIVE CONTROL COLUMN INPUTS

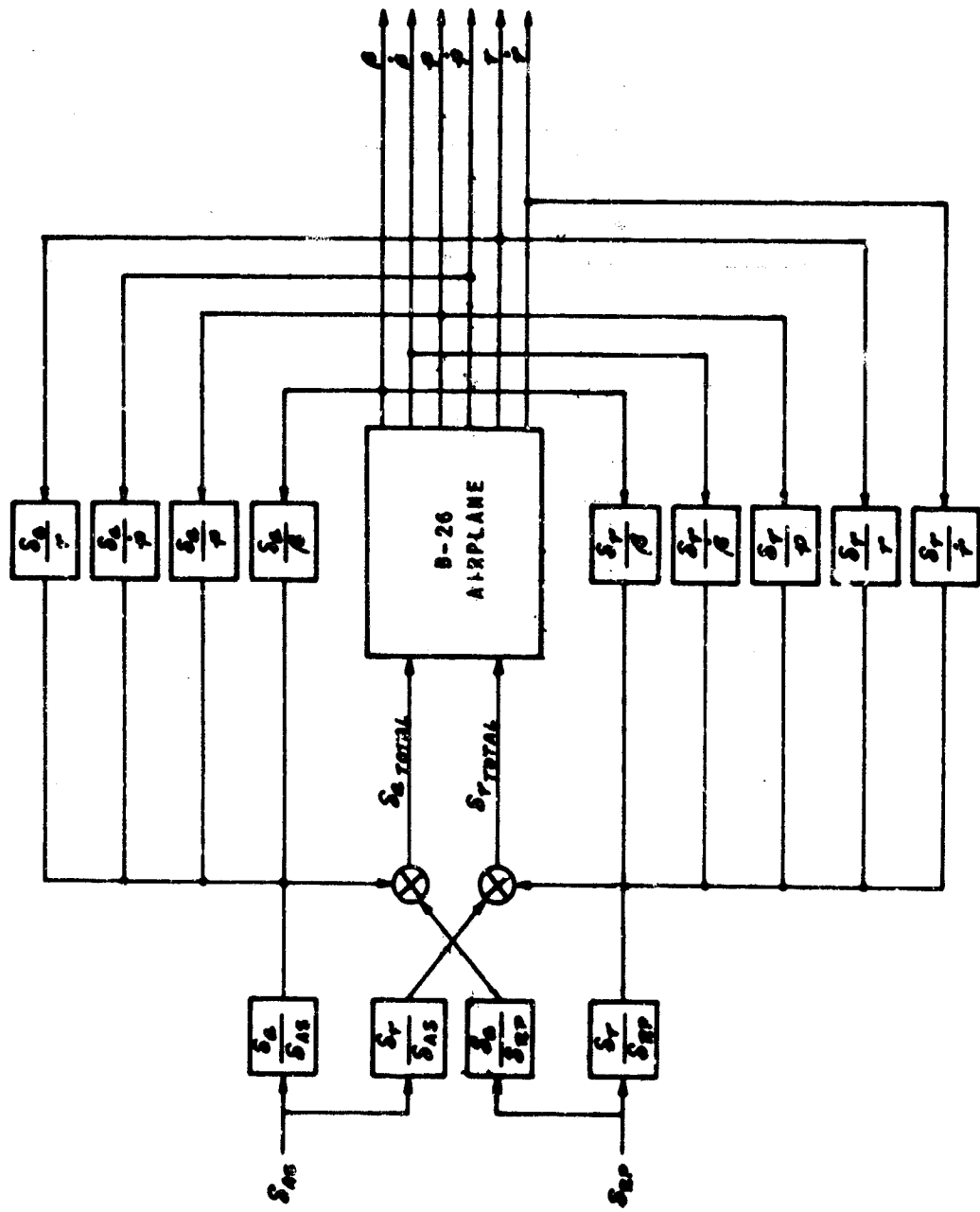

Figure 7 LATERAL-DIRECTIONAL RESPONSE FEEDBACK SIMULATION TECHNIQUE SHOWING GAINS USED

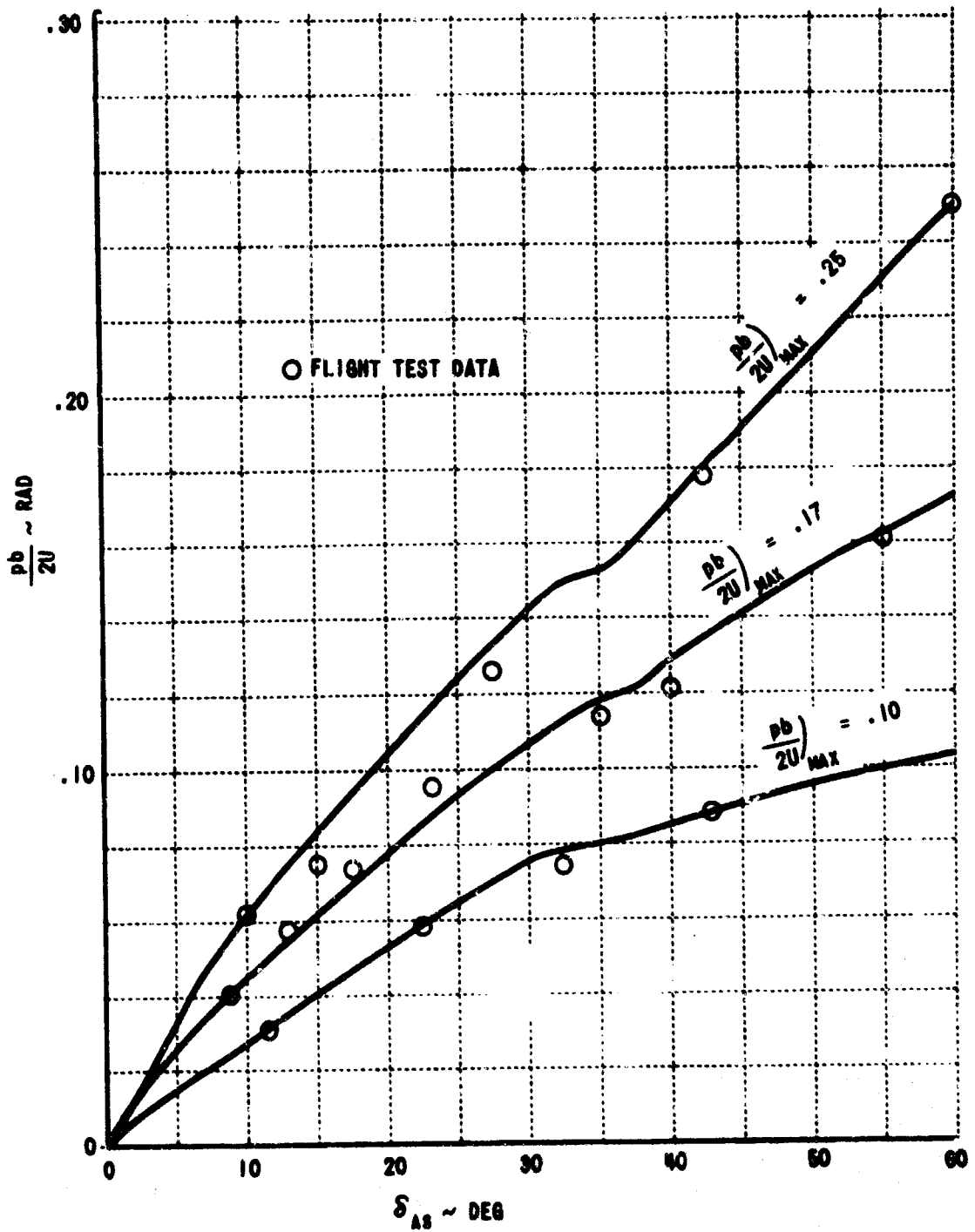
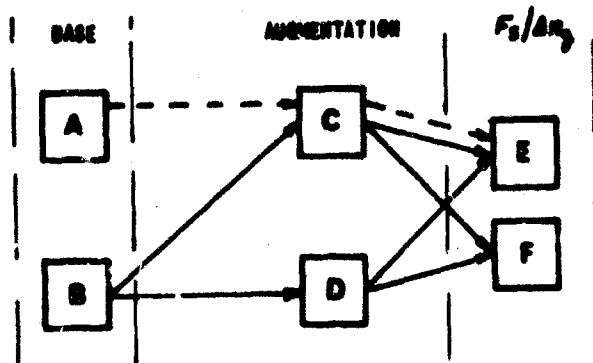
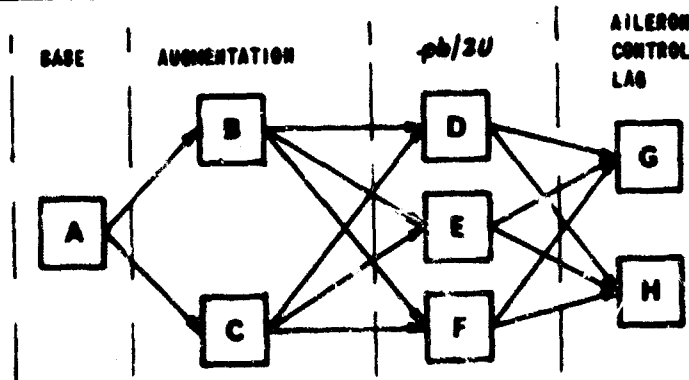

Figure 8 NONLINEAR ROLL CONTROL POWER CURVES APPROXIMATED BY FUNCTION GENERATOR

LONGITUDINAL



LATERAL-DIRECTIONAL



KEY

LONGITUDINAL

- A L-D AUGMENTATION OFF
- B L-D AUGMENTATION ON
- C LONGITUDINAL AUGMENTATION OFF
- D LONGITUDINAL AUGMENTATION ON
- E $F_s/\Delta n_y = 100 \text{ LB/g}$
- F $F_s/\Delta n_y = 100 \text{ LB/g}$

LATERAL-DIRECTIONAL

- A LONGITUDINAL AUGMENTATION ON
- B L-D AUGMENTATION OFF
- C L-D AUGMENTATION ON
- D $\phi b/2U = .104$
- E $\phi b/2U = .17$
- F $\phi b/2U = .25$
- G TIME TO REACH MAX ROLL CONTROL INPUT = .4 SEC
- H TIME TO REACH MAX ROLL CONTROL INPUT = .9 SEC

Figure 9 PROGRAM DIAGRAM

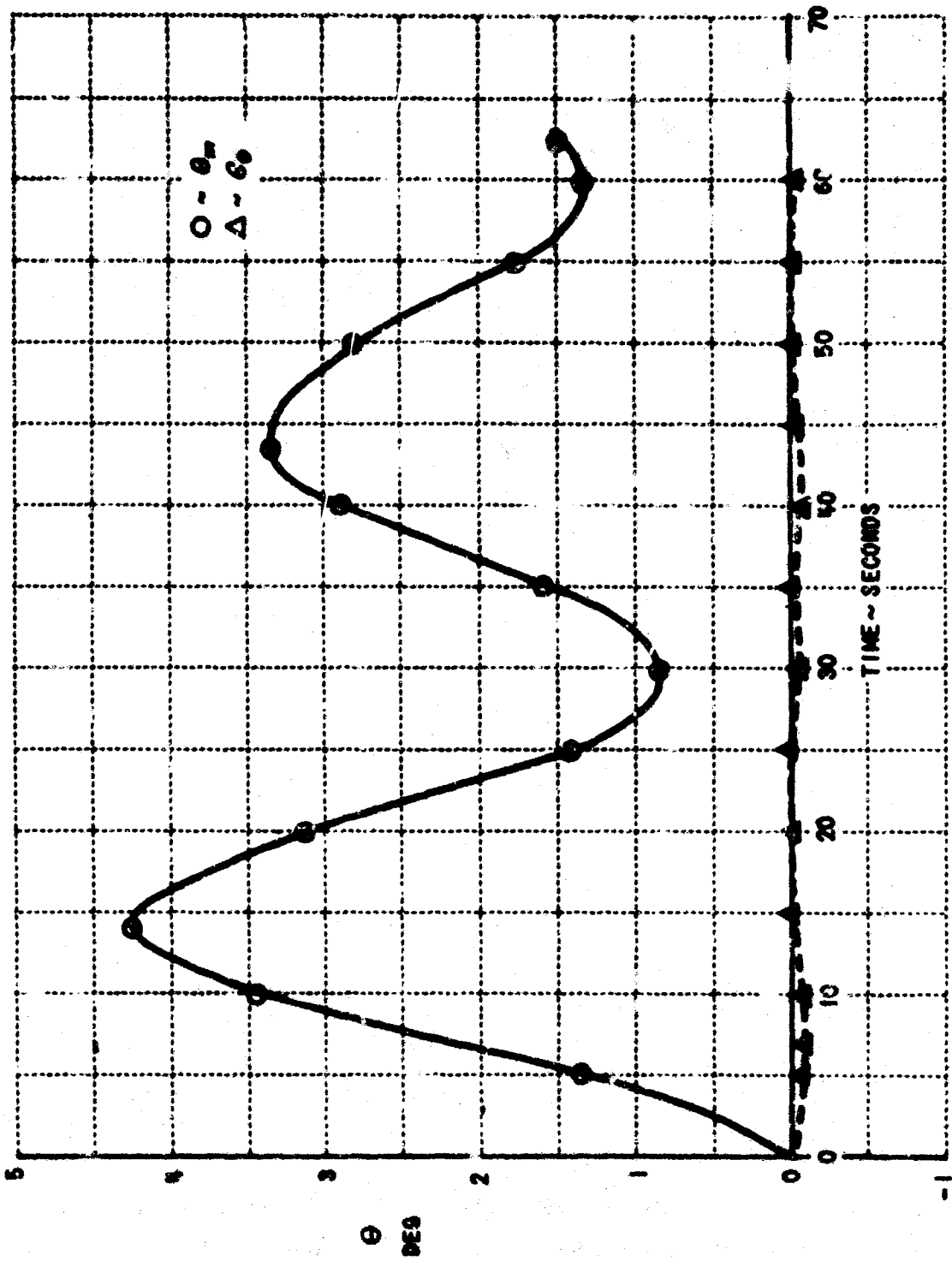

Figure 10 MODEL PITCH RESPONSE AND AIRPLANE PITCH RESPONSE ERROR TO $30^\circ \delta_c$ STEP COMMAND TO MODEL --- UNAugMENTED CASE

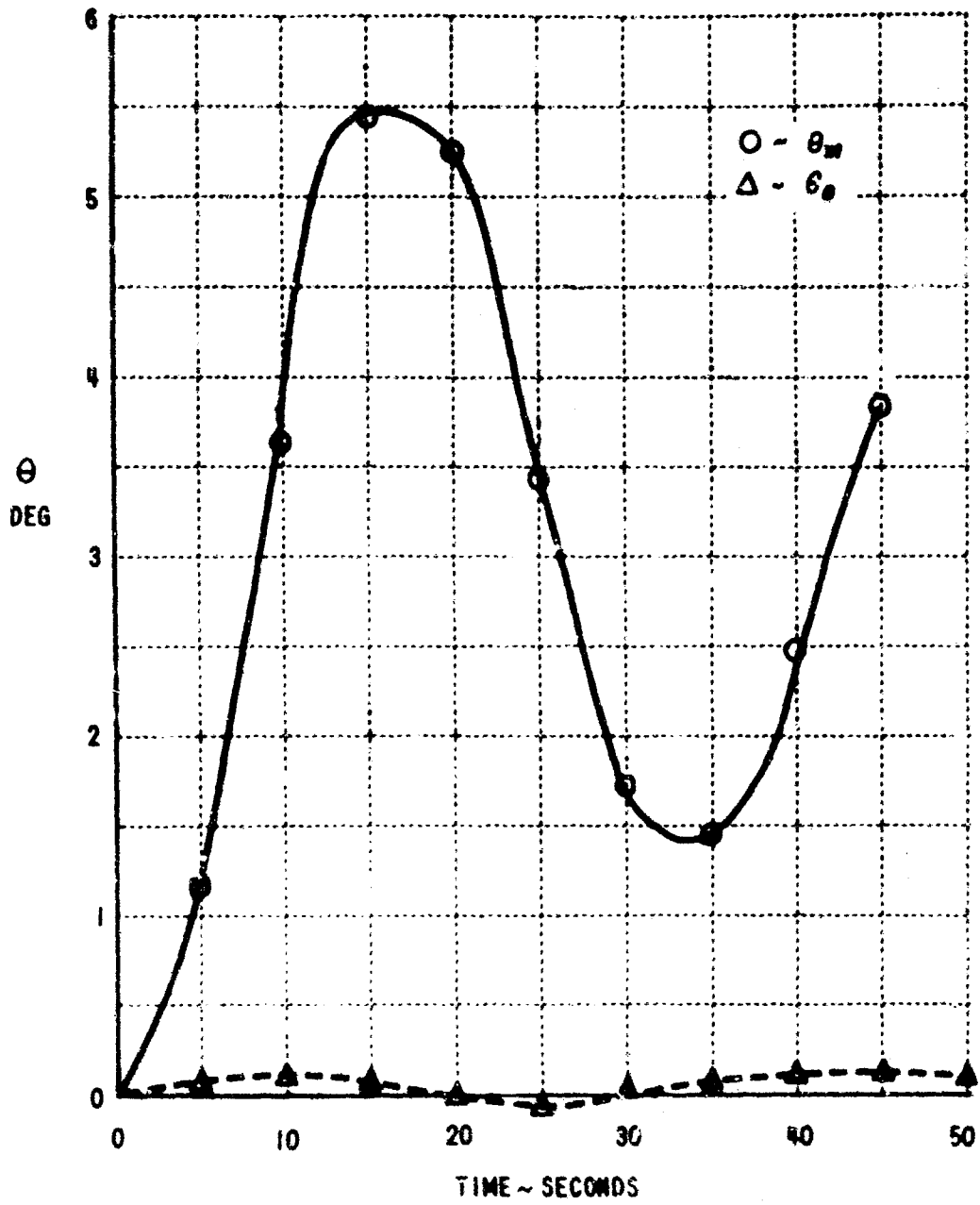

Figure 11 MODEL PITCH RESPONSE AND AIRPLANE PITCH RESPONSE ERROR TO A 20% THRUST STEP INPUT -- UNAugMENTED CASE

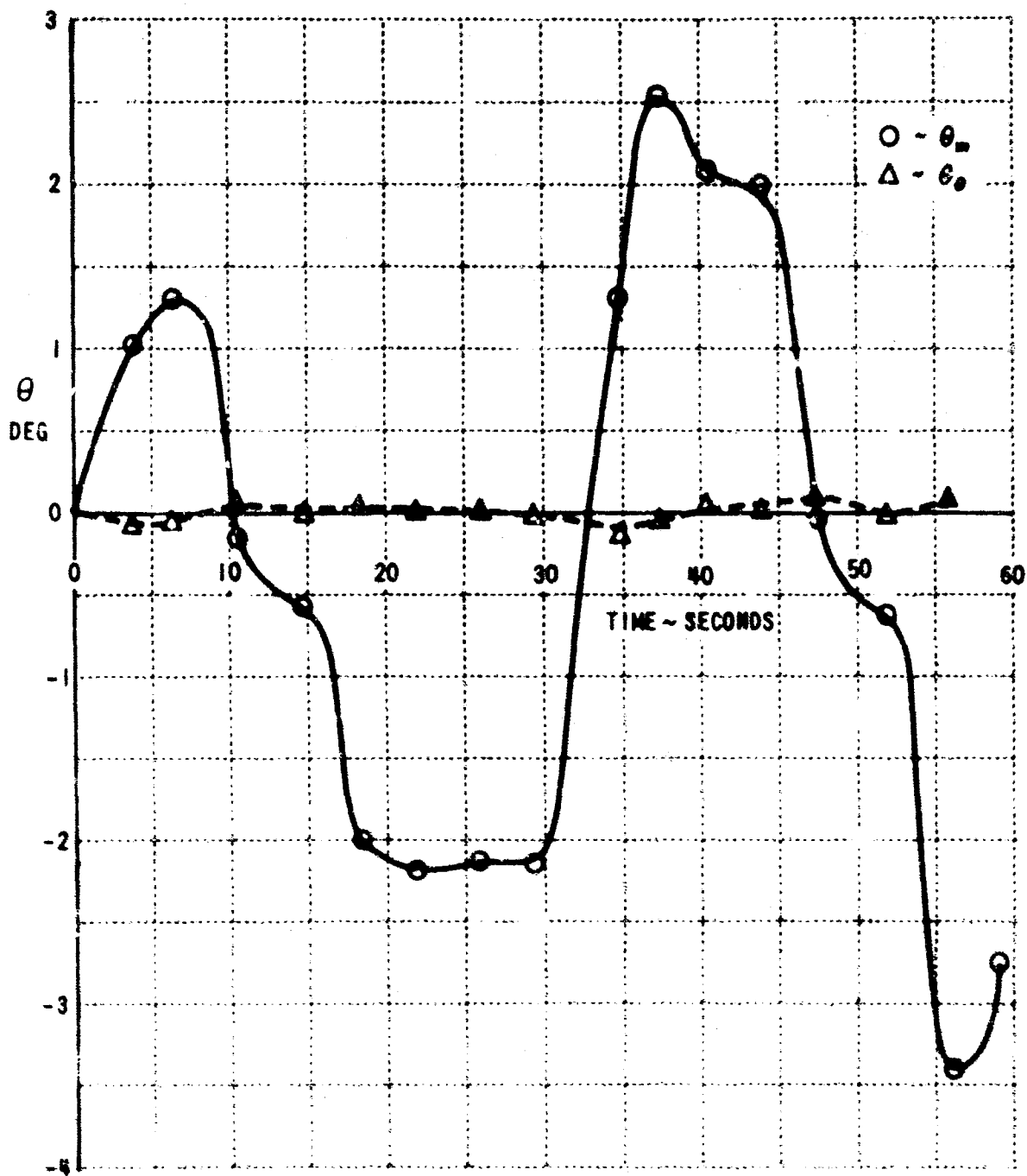

Figure 12 MODEL PITCH RESPONSE AND AIRPLANE PITCH RESPONSE ERROR DURING SHARP RANDOM PILOT-APPLIED CONTROL INPUTS -- UNAugMENTED CASE

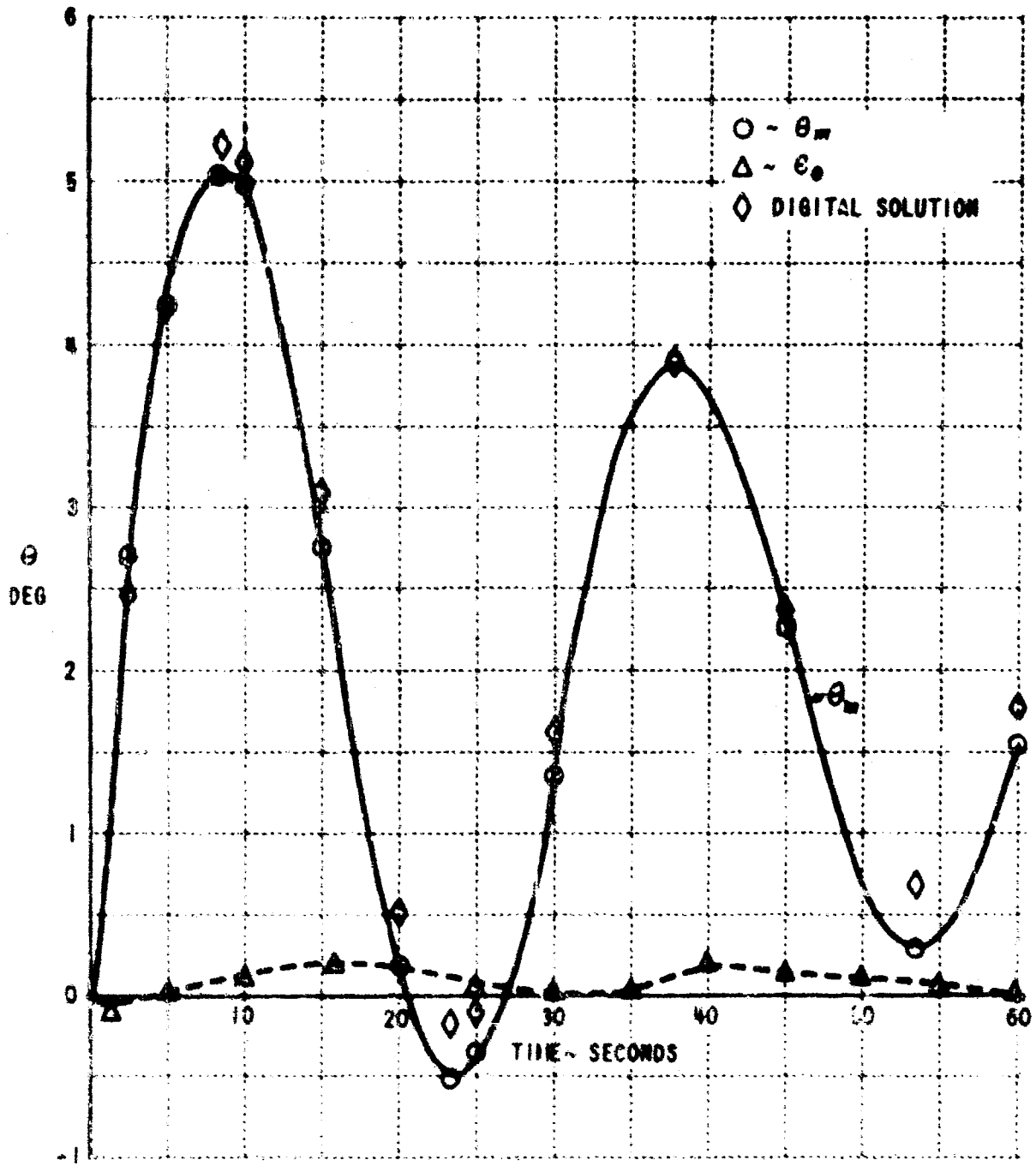

Figure 13 MODEL PITCH RESPONSE AND AIRPLANE PITCH RESPONSE ERROR TO $3^\circ \delta_e$ STEP COMMAND TO MODEL -- AUGMENTED CASE

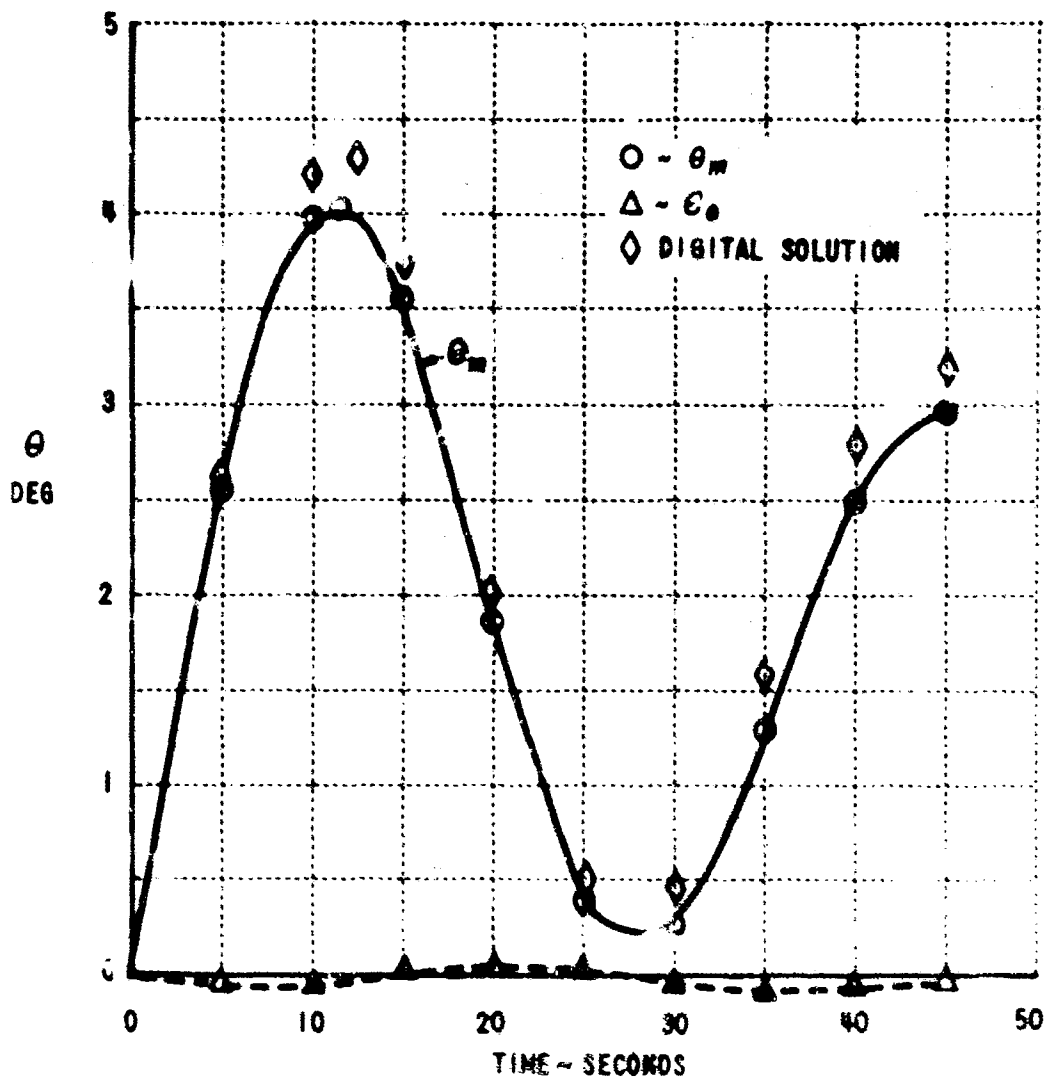

Figure 14 MODEL PITCH RESPONSE AND AIRPLANE PITCH RESPONSE ERROR TO A 20% THRUST STEP INPUT -- AUGMENTED CASE

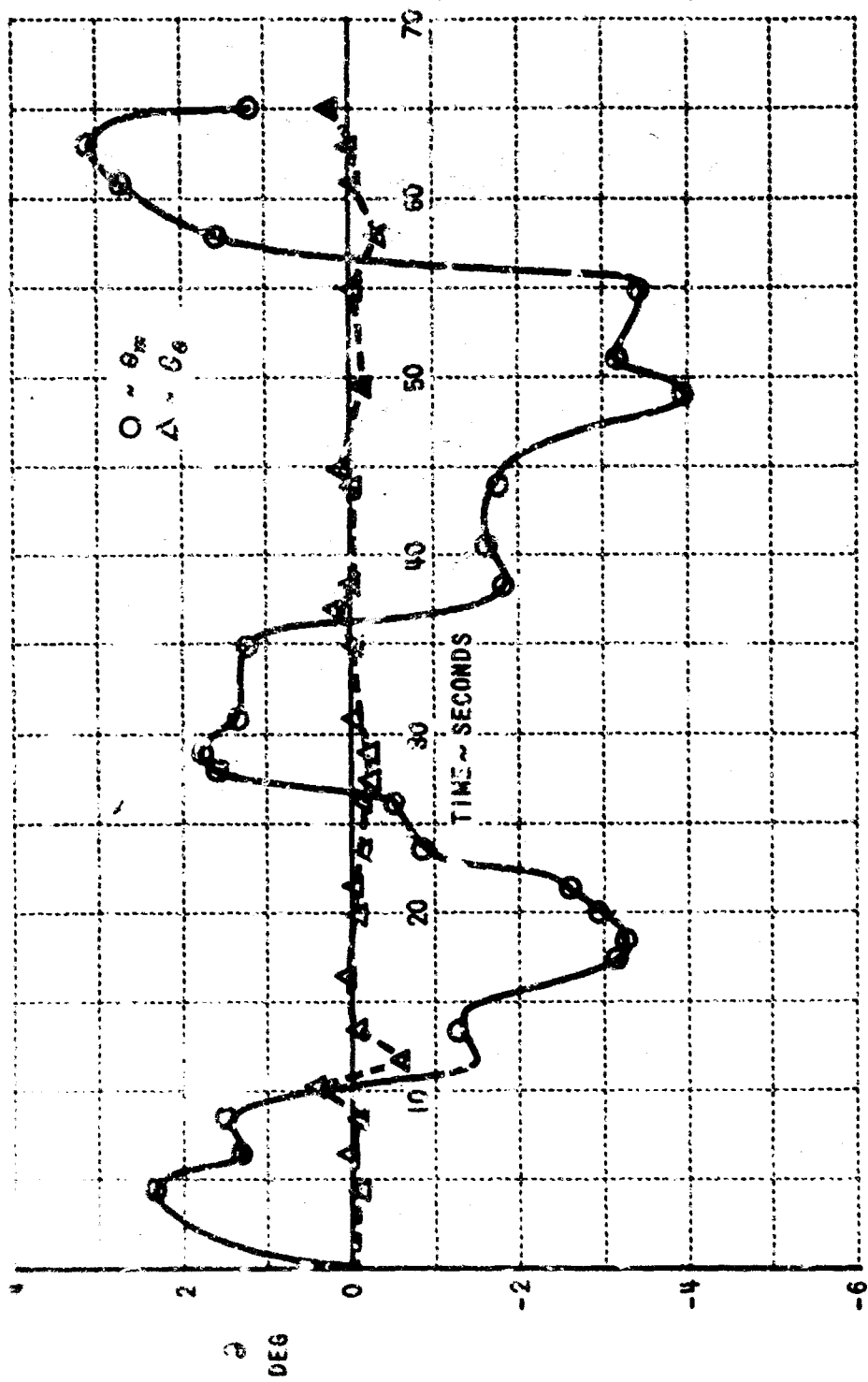

Figure 15 MODEL PITCH RESPONSE AND AIRPLANE PITCH RESPONSE ERROR DURING SHARP RANDOM PILOT-APPLIED CONTROL INPUTS -- AUGMENTED CASE

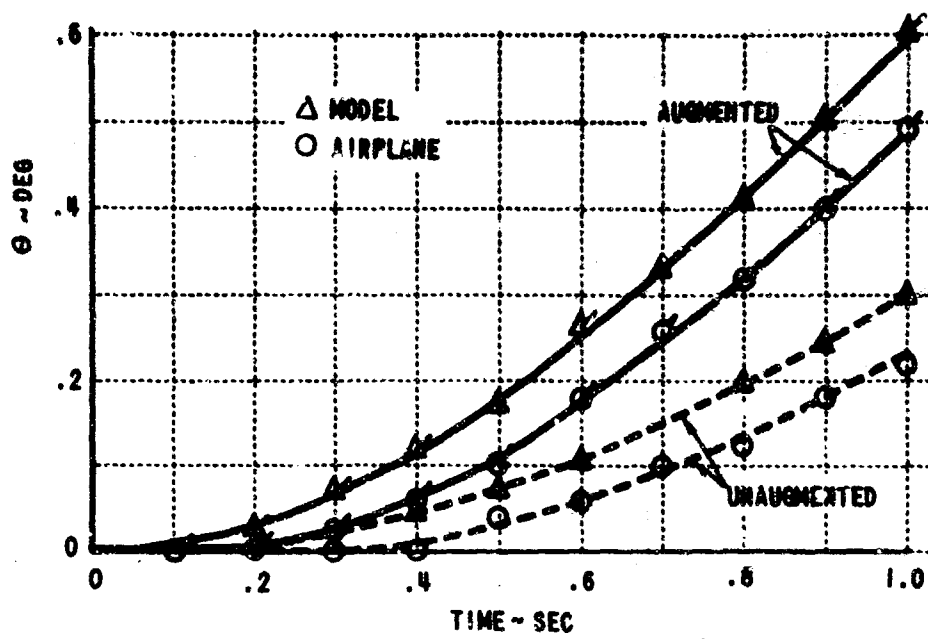

Figure 16 INITIAL Θ RESPONSE COMPARISON TO $3^\circ \delta_e$ STEP COMMAND

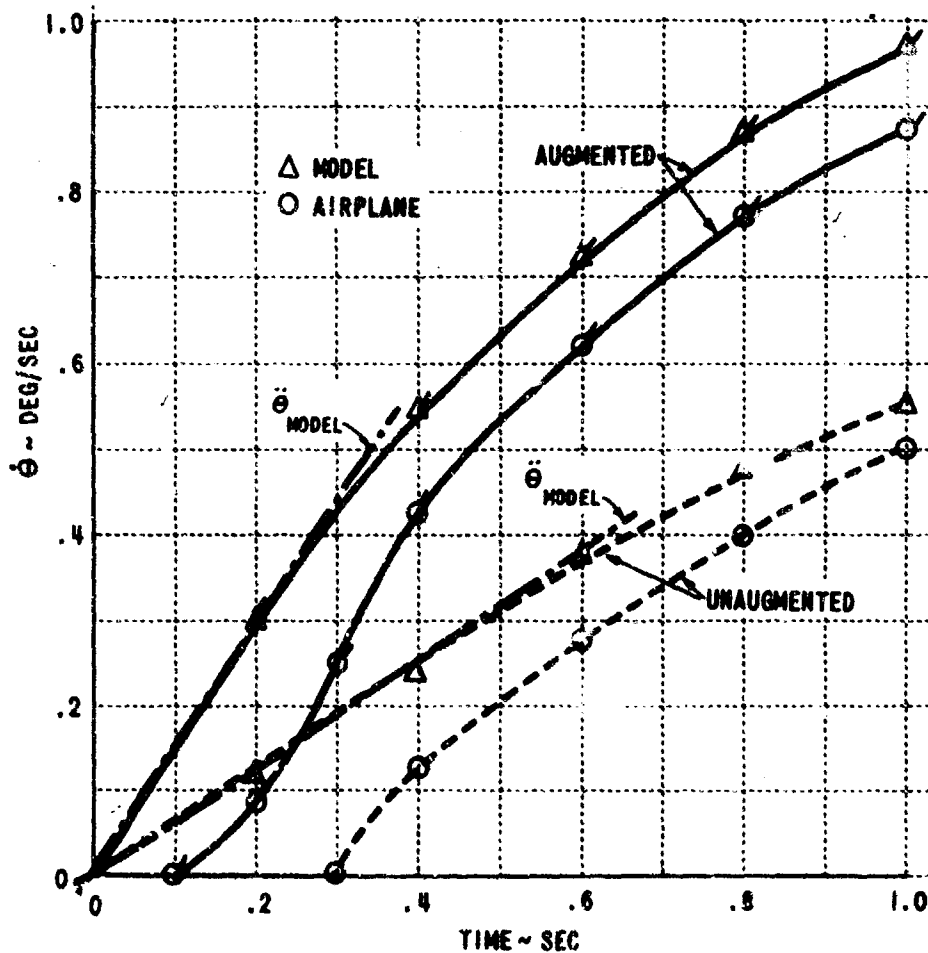

Figure 17 INITIAL $\dot{\Theta}$ AND $\ddot{\Theta}$ RESPONSES DERIVED FROM FIGURE 16

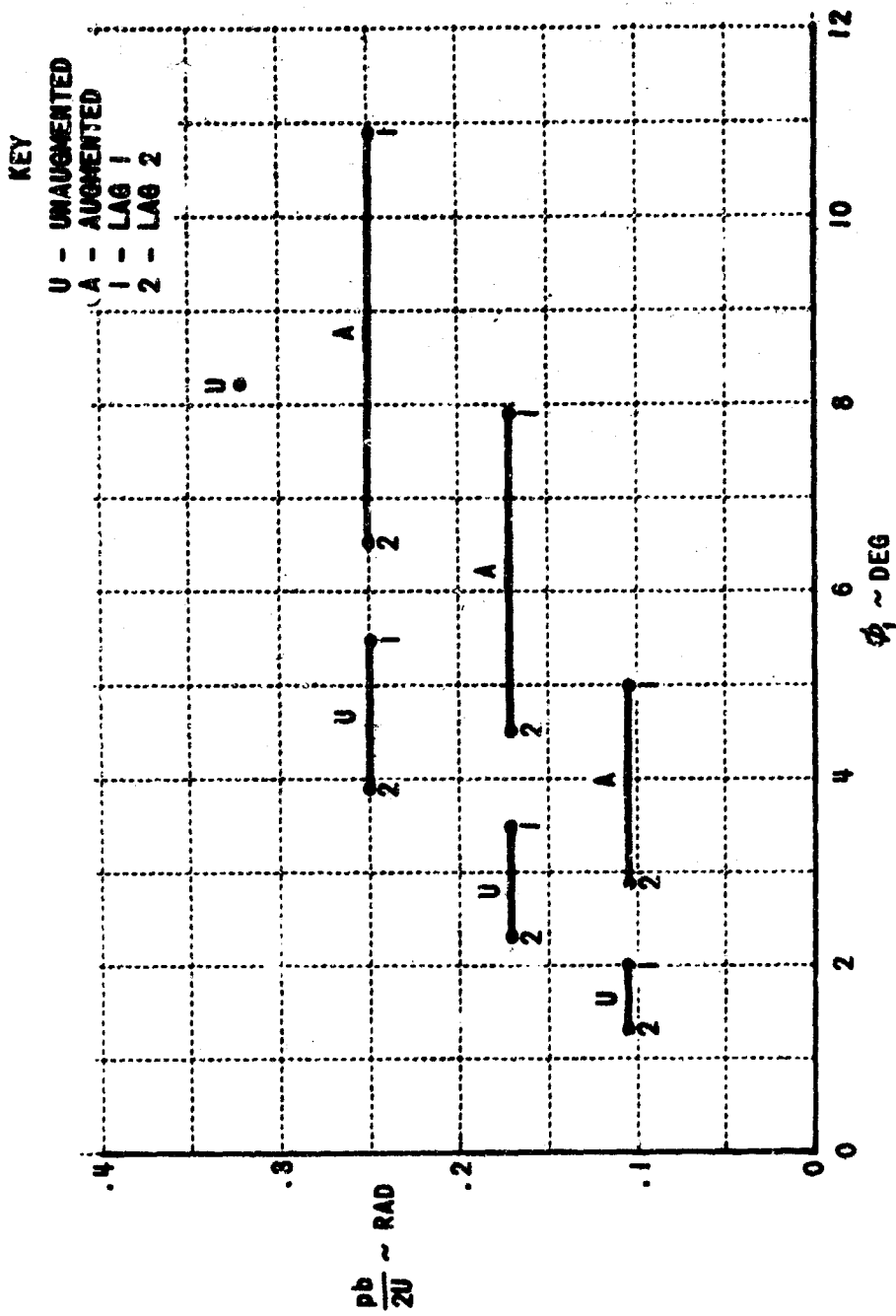

Figure 18 RANGE OF ϕ , INVESTIGATED

DIGITAL RESPONSES BASED ON LINEAR EQUATIONS AND
TRANSFERRED TO MEASUREMENT AXES.

FLIGHT RESPONSES INCLUDE
C-5A NONLINEAR C_L VS. β_{AS}

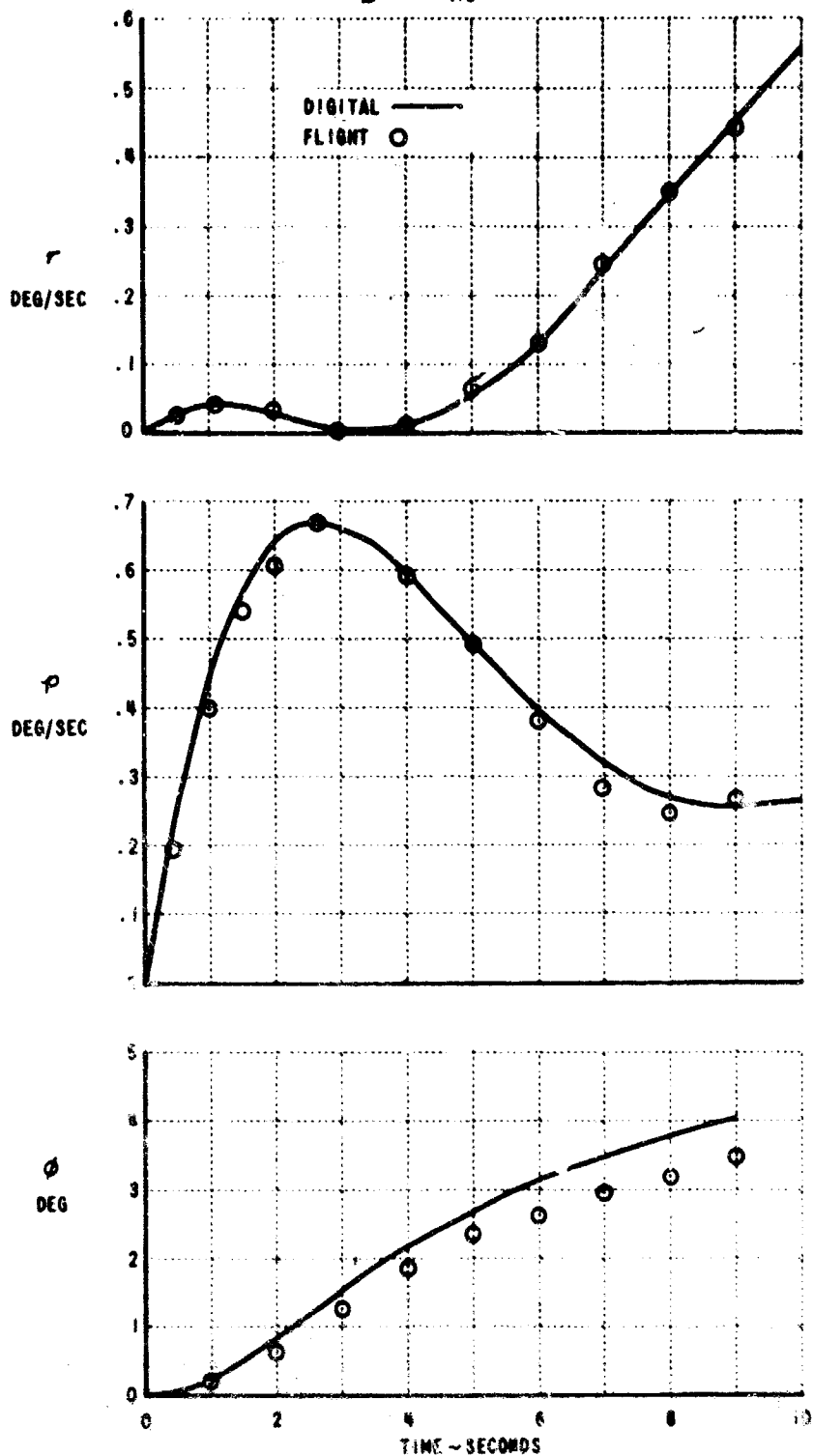

FIGURE 19 TYPICAL COMPARISON OF LATERAL-DIRECTIONAL RESPONSES
UNAugMENTED CASE, 1° STEP INPUT

DIGITAL RESPONSES BASED ON LINEAR EQUATIONS AND
 TRANSFERRED TO MEASUREMENT AXES.

FLIGHT RESPONSES INCLUDE
 C-5A NONLINEAR C_L VS. δ_{AS}

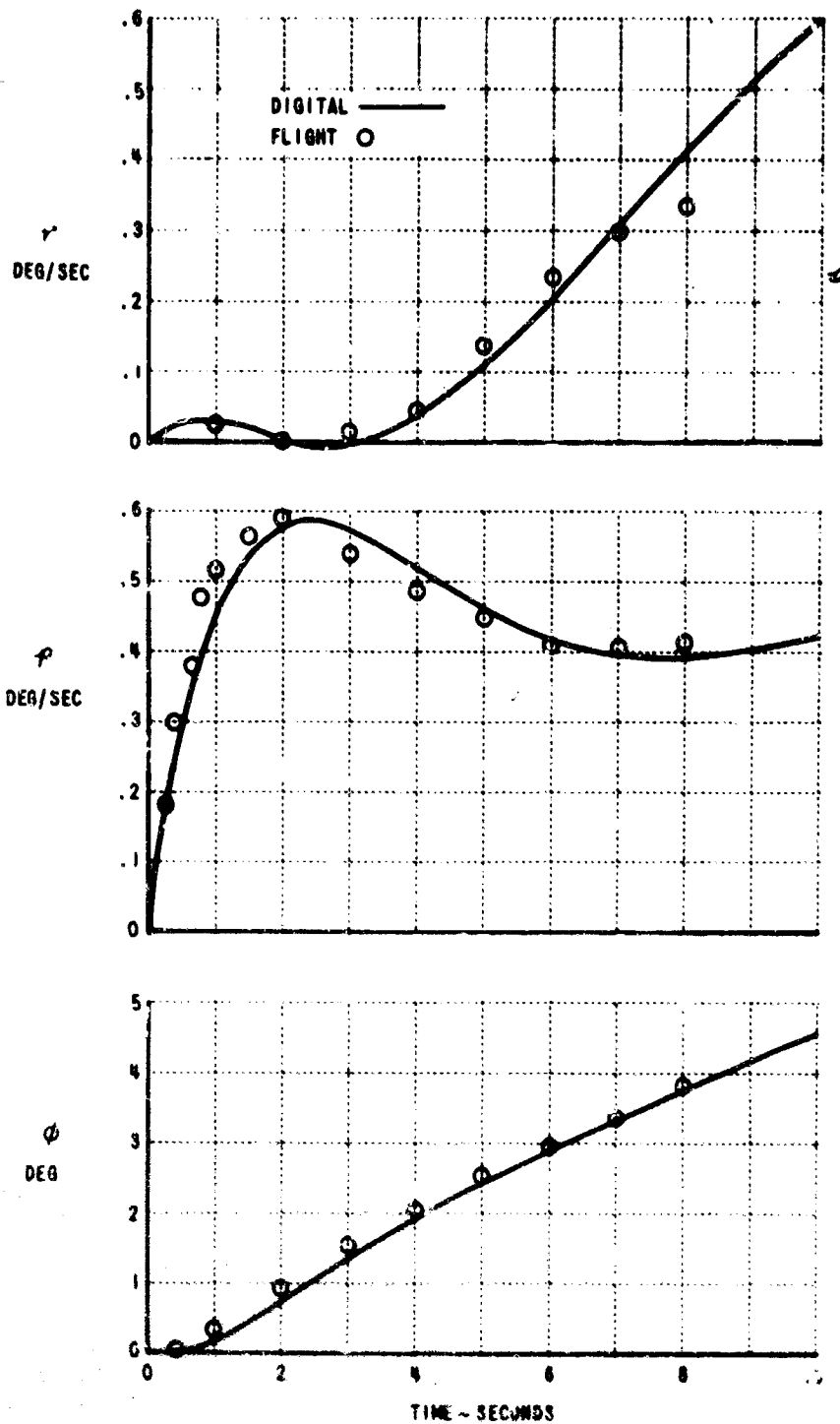

FIGURE 20 TYPICAL COMPARISON OF LATERAL-DIRECTIONAL RESPONSES
 AUGMENTED CASE, $1^\circ \delta_{AS}$ STEP INPUT

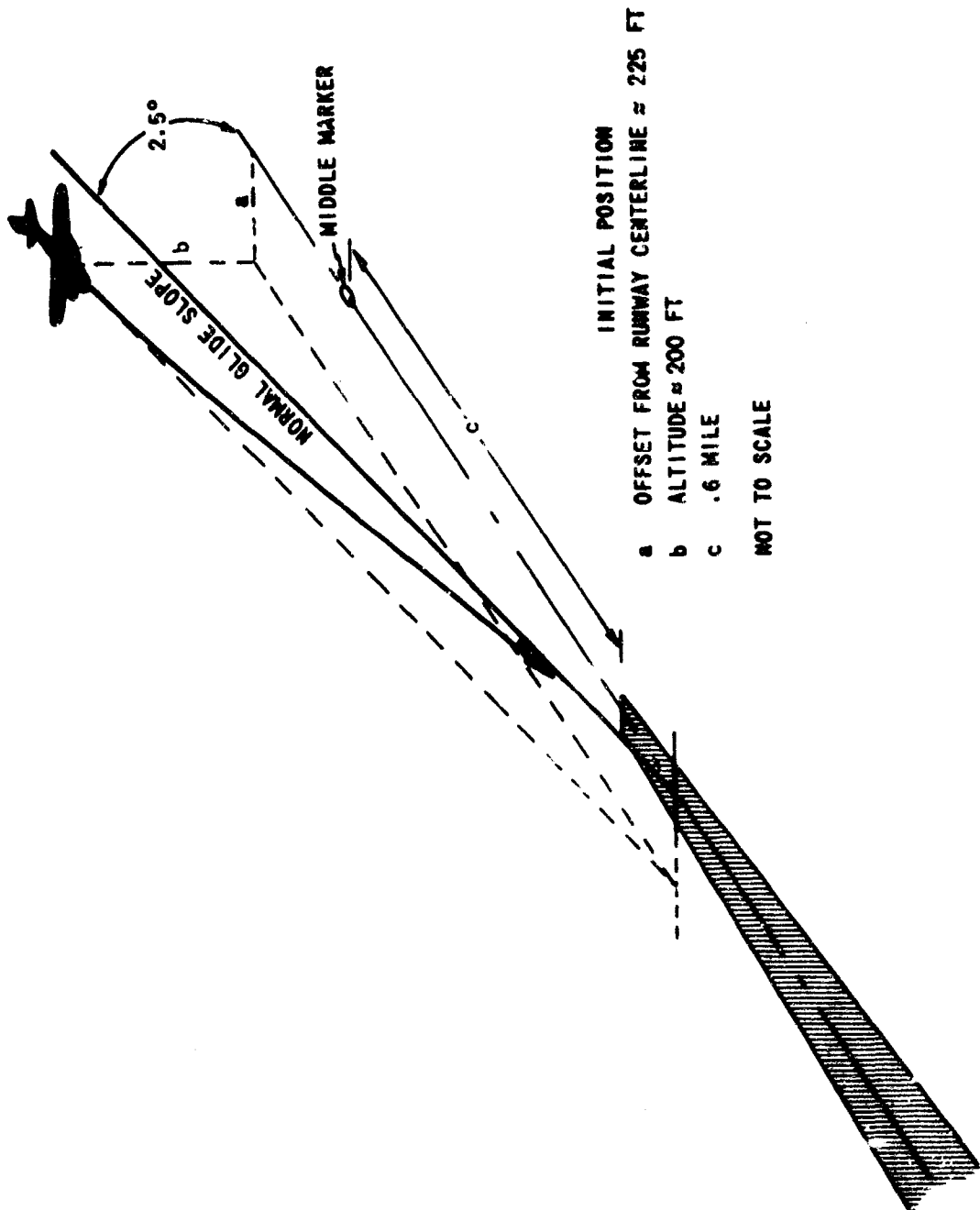

Figure 21 GEOMETRY OF OFFSET MANEUVER

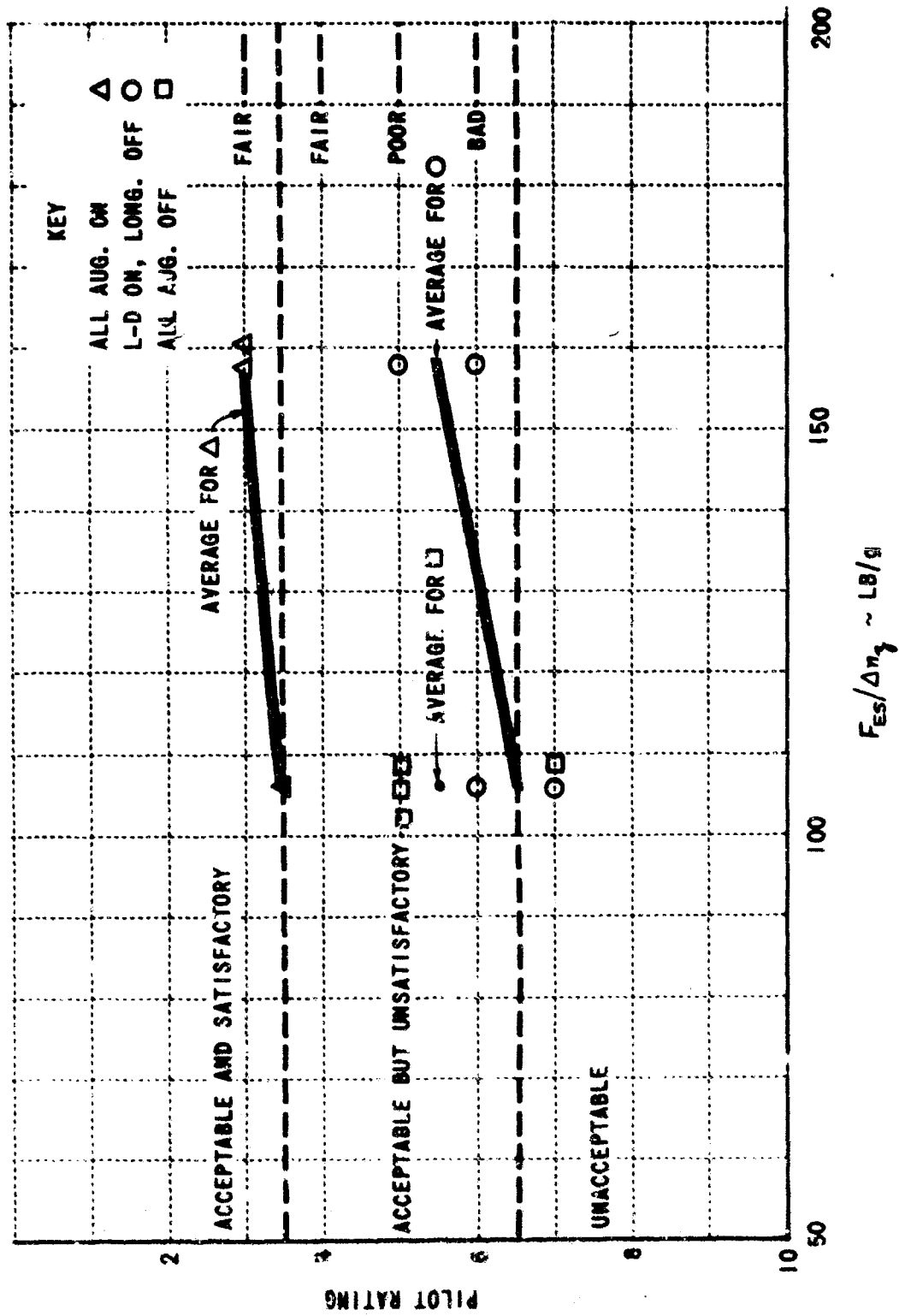

Figure 22 LONGITUDINAL EVALUATION -- PILOT A
RATINGS INCLUDE LATERAL-DIRECTIONAL CHARACTERISTICS

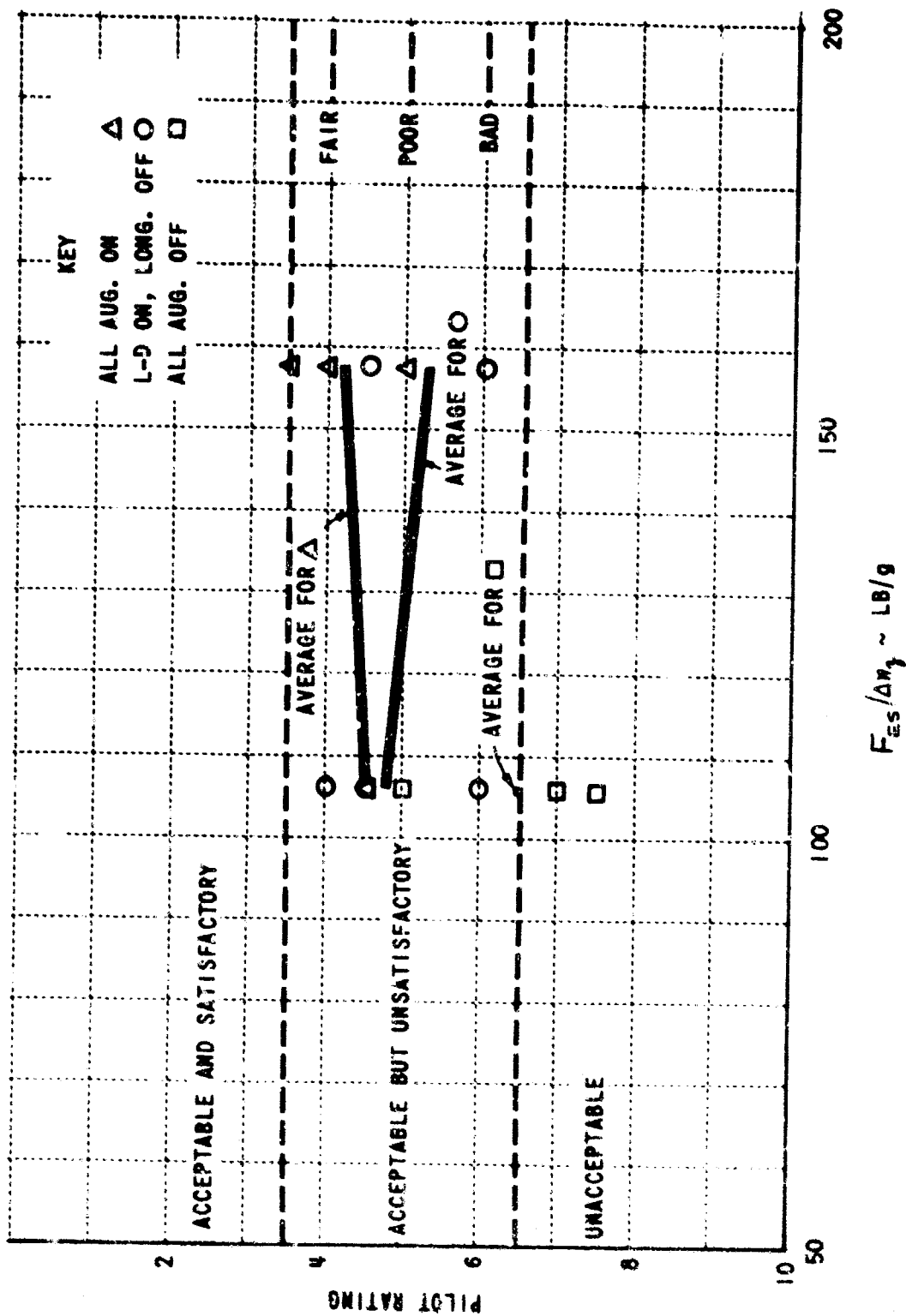

Figure 23 LONGITUDINAL EVALUATION -- PILOT B
RATINGS INCLUDE LATERAL-DIRECTIONAL CHARACTERISTICS

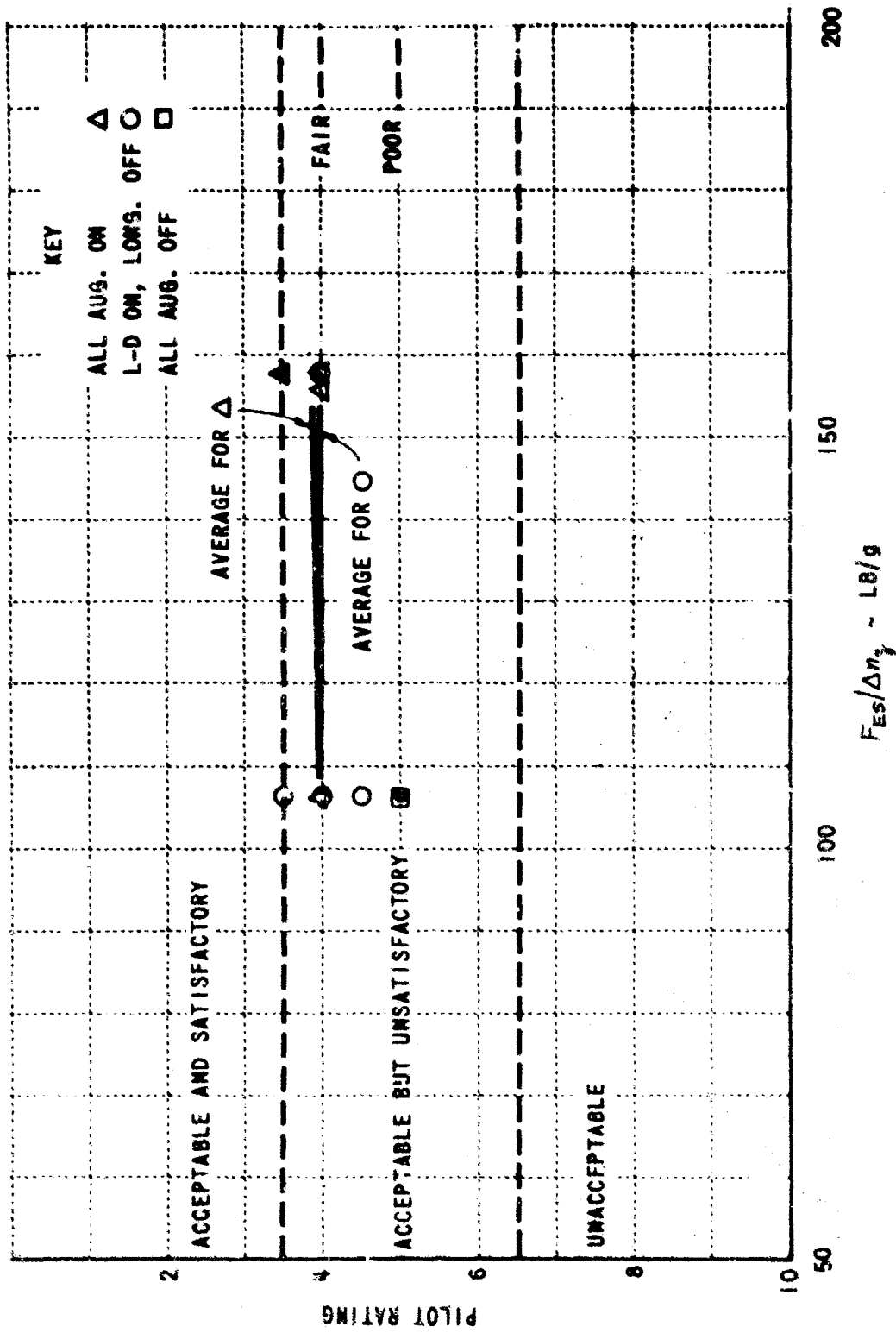

Figure 24 LONGITUDINAL EVALUATION -- PILOT P
RATINGS BASED ON LONGITUDINAL CHARACTERISTICS ONLY

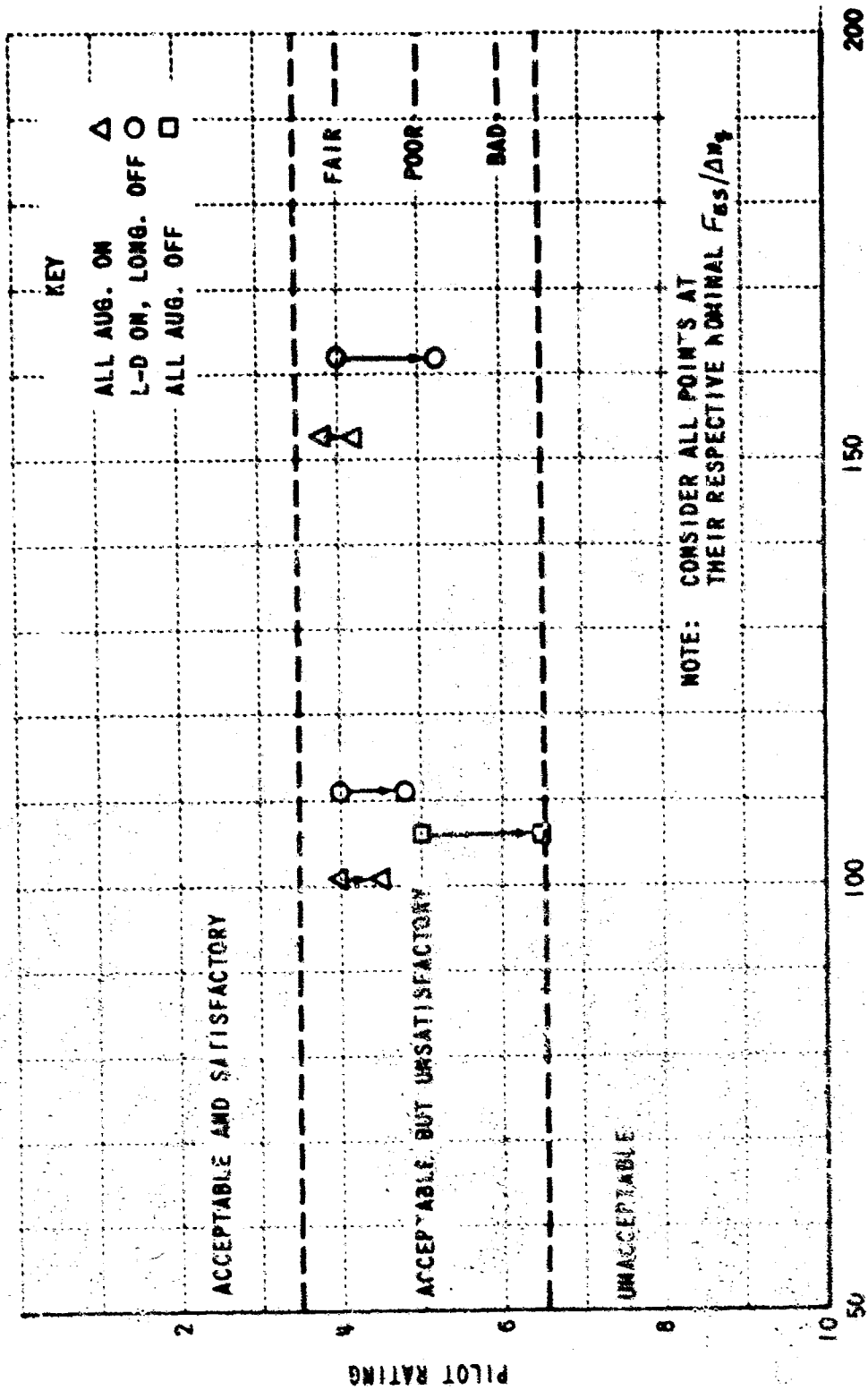

Figure 25 LONGITUDINAL EVALUATION --- PILOT'S CHANGE IN AVERAGE RATINGS WHEN LATERAL-DIRECTIONAL AS WELL AS LONGITUDINAL CHARACTERISTICS ARE CONSIDERED

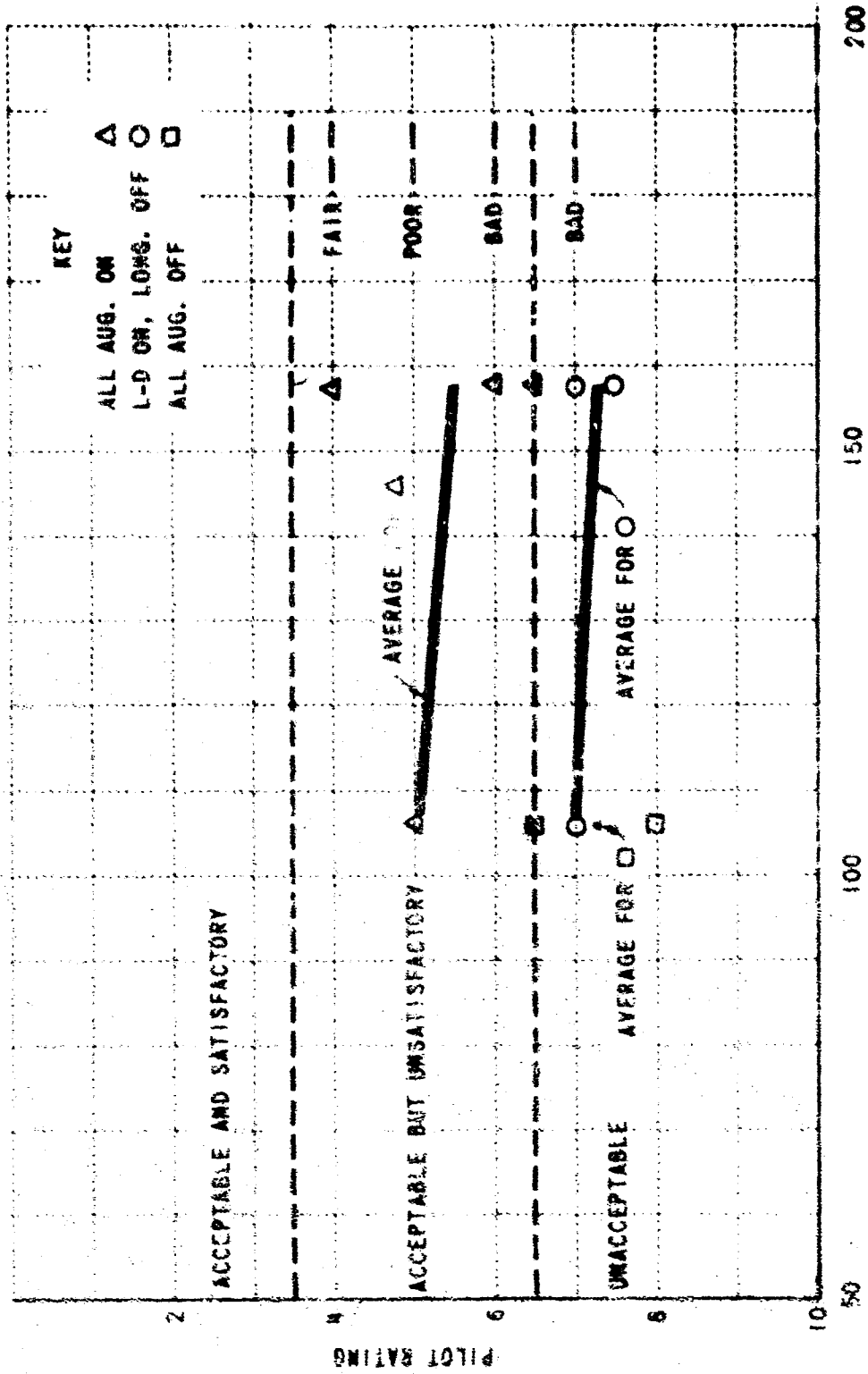

Figure 26 LONGITUDINAL EVALUATION -- PILOT C
 RATINGS INCLUDE LATERAL-DIRECTIONAL CHARACTERISTICS

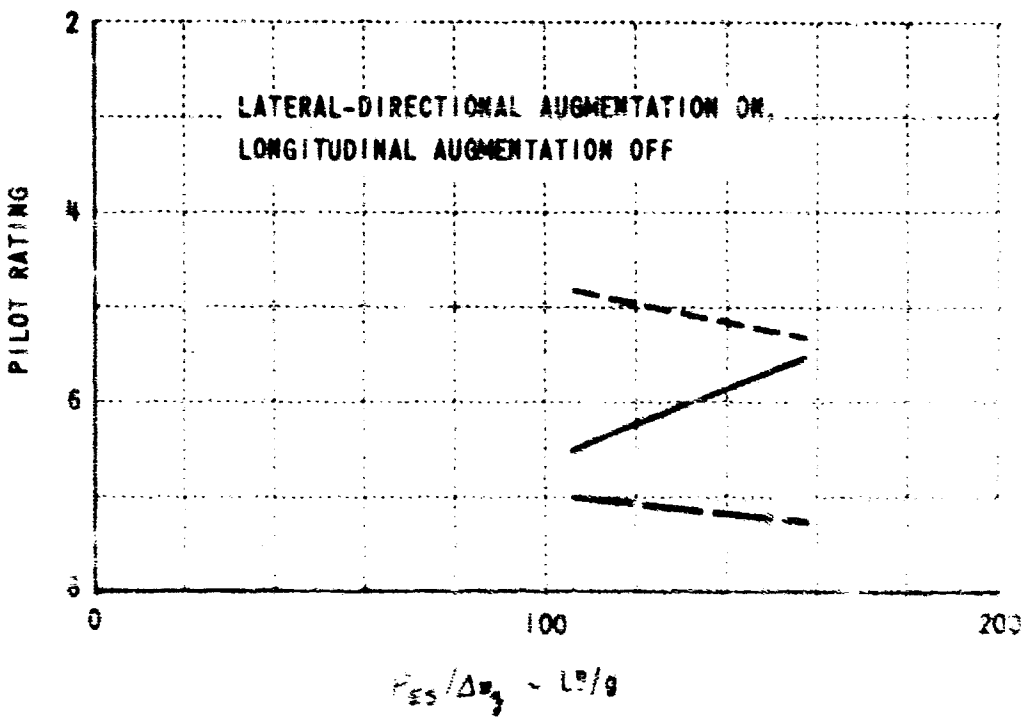
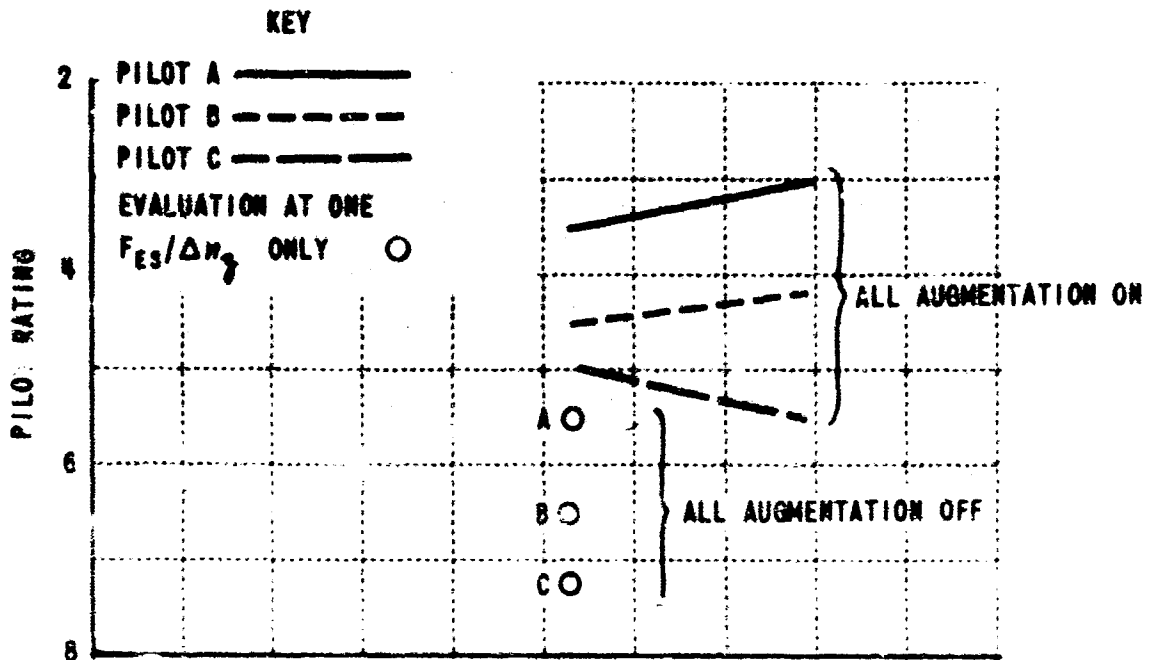

Figure 27 LONGITUDINAL EVALUATION -- COMPARISON OF INDIVIDUAL AVERAGED PILOT DATA

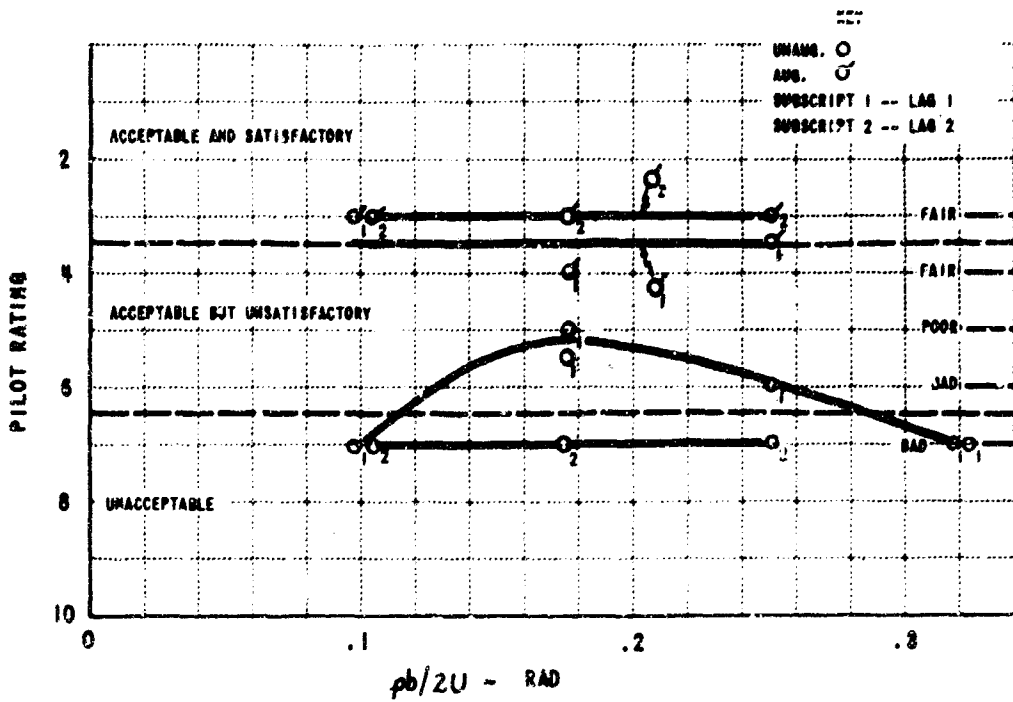

Figure 28 LATERAL-DIRECTIONAL EVALUATION -- PILOT A, EFFECT OF $pb/2U$
RATINGS INCLUDE LONGITUDINAL CHARACTERISTICS

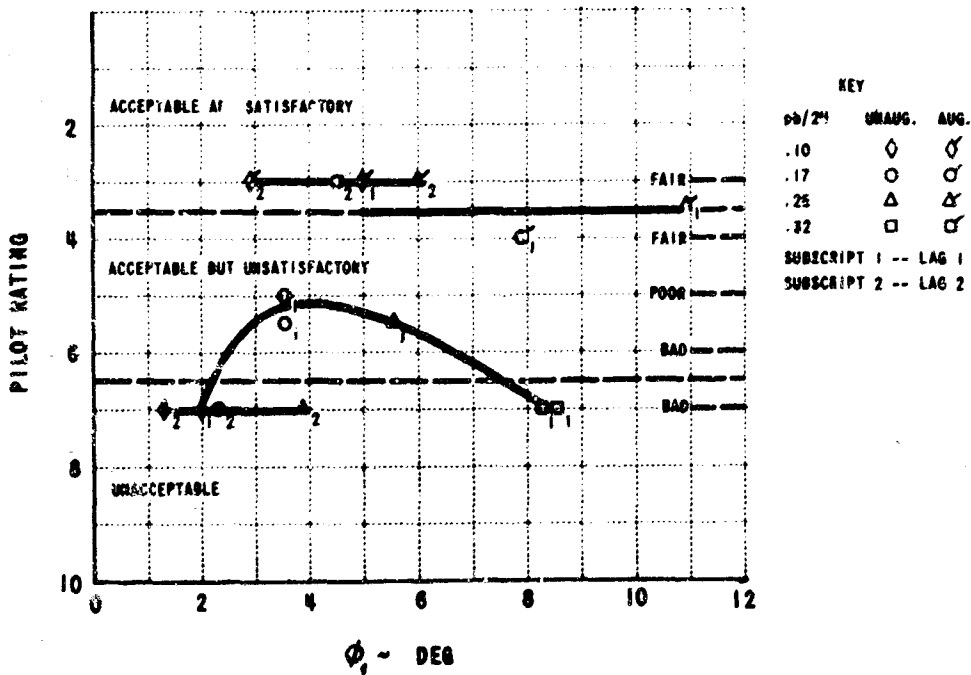

Figure 29 LATERAL-DIRECTIONAL EVALUATION -- PILOT A, EFFECT OF ϕ_1
RATINGS INCLUDE LONGITUDINAL CHARACTERISTICS

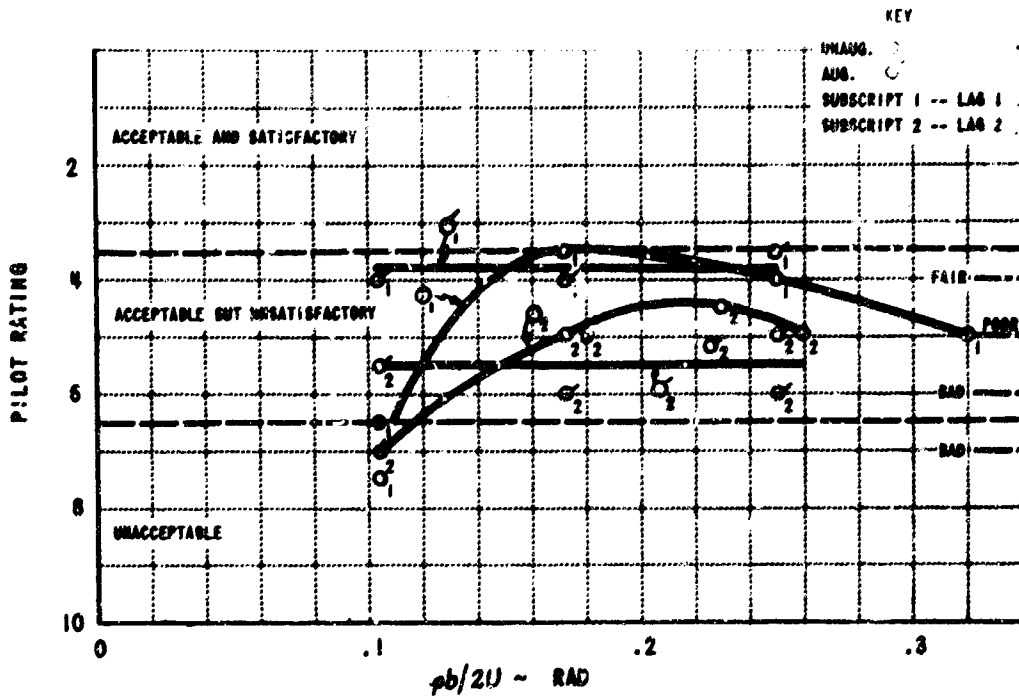

Figure 30 LATERAL-DIRECTIONAL EVALUATION -- PILOT B, EFFECT OF $pb/2U$ RATINGS INCLUDE LONGITUDINAL CHARACTERISTICS

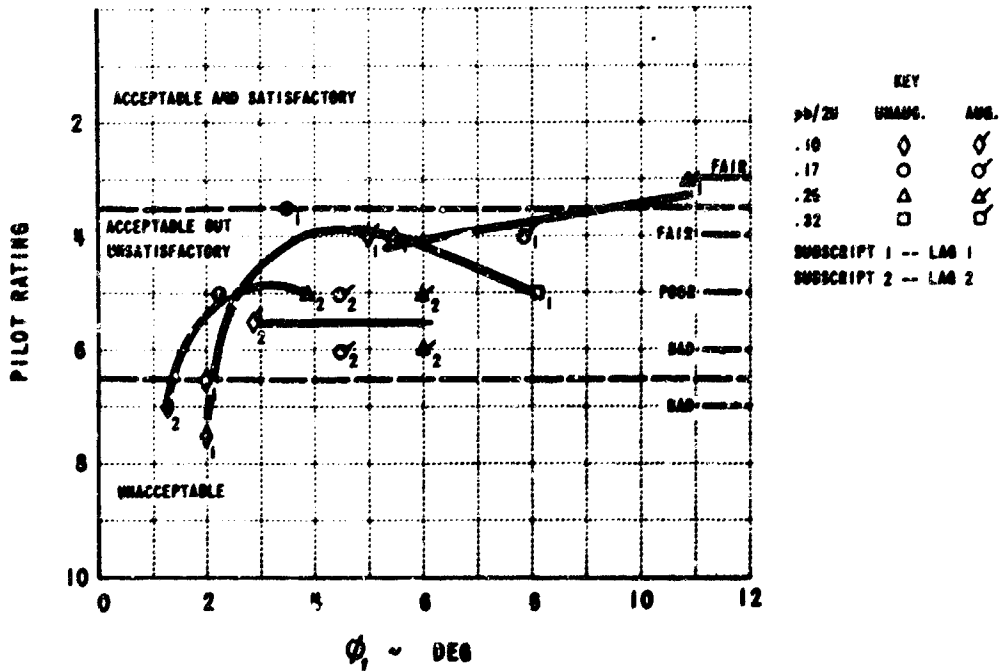

Figure 31 LATERAL-DIRECTIONAL EVALUATION -- PILOT B, EFFECT OF ϕ_1 RATINGS INCLUDE LONGITUDINAL CHARACTERISTICS

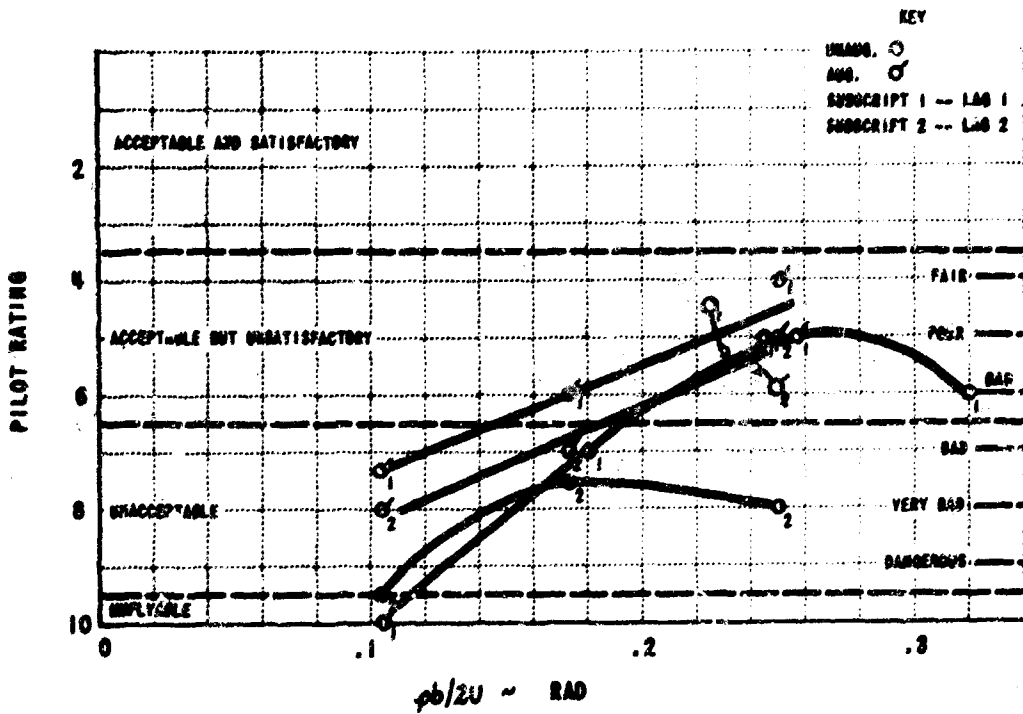

Figure 32 LATERAL-DIRECTIONAL EVALUATION -- PILOT C, EFFECT OF $pb/2U$
 RATINGS INCLUDE LONGITUDINAL CHARACTERISTICS

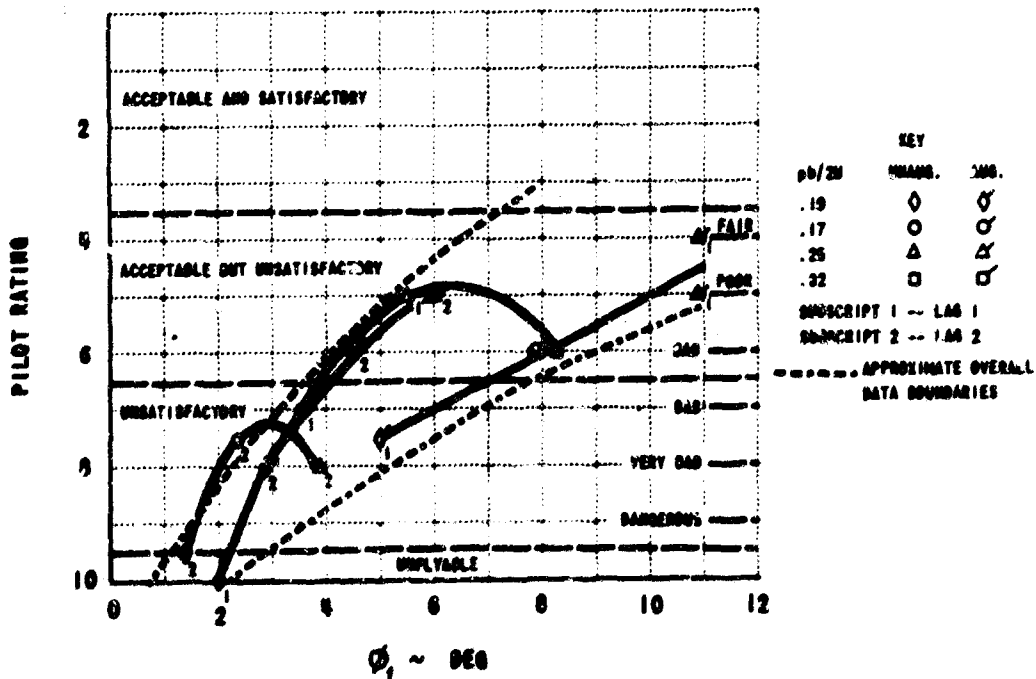

Figure 33 LATERAL-DIRECTIONAL EVALUATION -- PILOT C, EFFECT OF ϕ_1
 RATINGS INCLUDE LONGITUDINAL CHARACTERISTICS

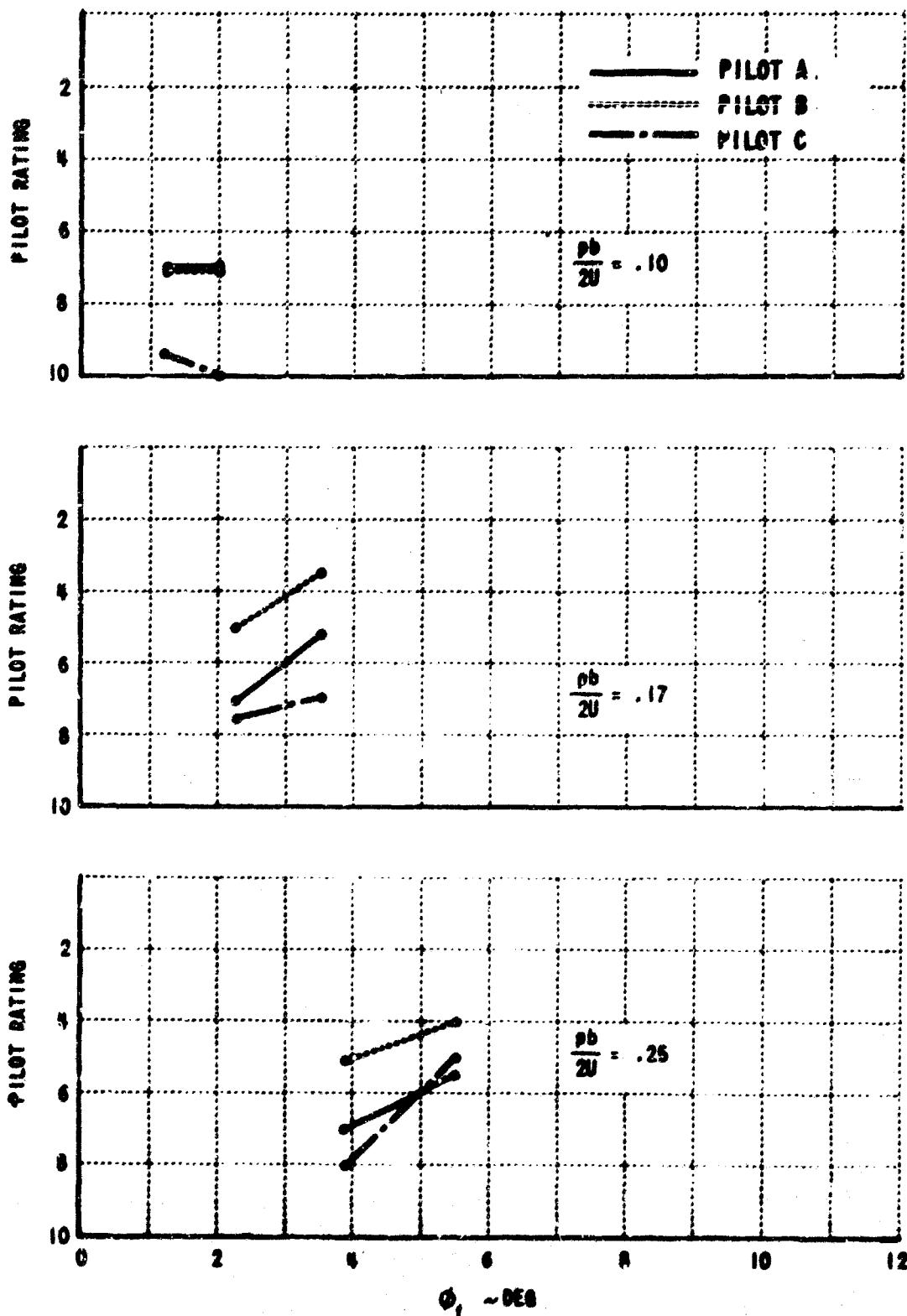

Figure 24 PILOT COMPARISON OF LATERAL-DIRECTIONAL EVALUATION UNAugMENTED CONFIGURATION

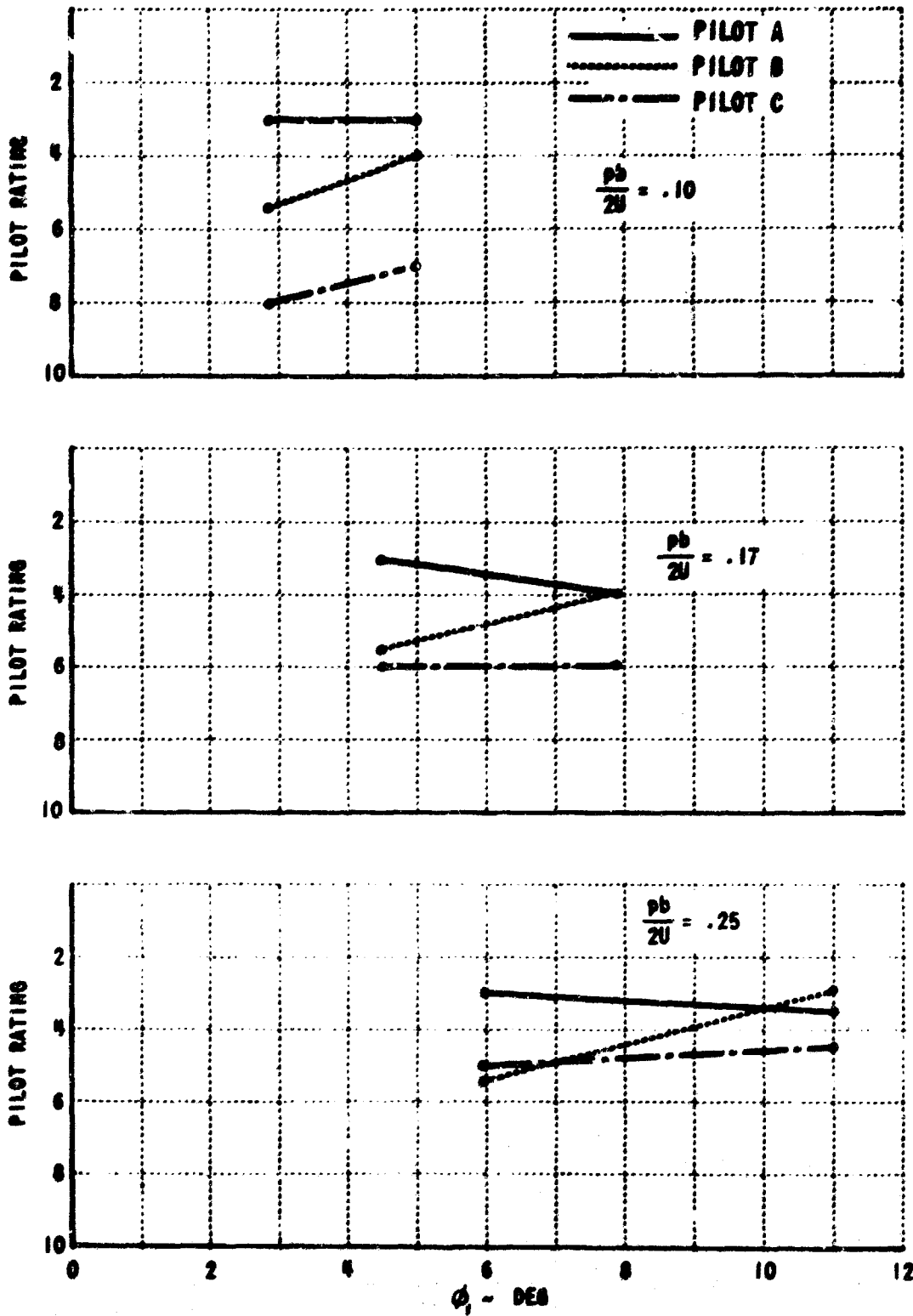

Figure 35 PILOT COMPARISON OF LATERAL-DIRECTIONAL EVALUATION AUGMENTED CONFIGURATION

**APPENDIX I
LARGE AIRPLANE DATA AND EQUATIONS OF MOTION**

LONGITUDINAL

The following data were programmed into the airborne analog computer to form the large airplane model. These data are representative of the C-5A airplane as of April 1966 and are for the unaugmented configuration. The augmented configuration was developed by changing $C_{m\dot{\alpha}}$ and $C_{m\dot{q}}$ to achieve the required short period frequency and damping.

$W = 450,000 \text{ lb}$	$\alpha_0 = 2.7 \text{ deg}$
$S = 6200 \text{ ft}^2$	$C_{D\dot{\alpha}} = .703/\text{rad}$
$b = 219.2 \text{ ft}$	$C_{L\dot{\alpha}} = 5.61/\text{rad}$
$c = 30.9 \text{ ft}$	$C_{L\dot{s}_e} = .2643/\text{rad}$
$q_{TL} = 4 \text{ ft}$	$C_{m\dot{\alpha}} = -1.877/\text{rad}$
$I_y = 25 \times 10^6 \text{ slug-ft}^2$	$C_{m\dot{\omega}} = -8.72/\text{rad}$
$\bar{q} = 37.4 \text{ lb/ft}^2$	$C_{m\dot{q}} = -23.98/\text{rad}$
$V = 178 \text{ ft/sec}$	$C_{m\dot{\delta}_e} = -1.219/\text{rad}$
$\rho = .002378$	$\partial T/\partial V = -106.3 \text{ lb-sec/ft}$
$C_{D_0} = .281$	$T_0 = 65,150 \text{ lb}$
$C_{L_0} = 1.95$	$\partial T/\partial \delta_T = 1,148 \text{ lb/percent}$

The following equations of motion represent the model. The subscript "m" denotes model.

- a. Drag equation with respect to wind axis.

$$\dot{V}_m = -D_v \Delta V_m - D_{\dot{\alpha}} \frac{\Delta \alpha_m}{57.3} - D_{\dot{\theta}_m} \frac{\Delta \theta_m}{57.3} - D_{\delta_T} \delta_T$$

where

$$D_v = \frac{1}{m} \left[\rho V_0 S C_{D_0} - \left(\frac{\partial T}{\partial V} \right) \cos \alpha_0 \right]$$

$$D_{\dot{\alpha}} = \frac{\bar{q} S}{m} C_{D\dot{\alpha}} + \frac{T_0}{m} \sin \alpha_0 - g \cos \gamma_0$$

$$D_{\dot{\theta}_m} = g \cos \gamma_0$$

$$D_{\delta_T} = \frac{\cos \alpha_0}{m} \frac{\partial T}{\partial \delta_T}$$

δ_T is % thrust

b. z-force equation with respect to the z body axis.

$$\dot{z}_m = 57.3 \gamma_V \Delta V_m + \gamma_\alpha \Delta \alpha_m + \gamma_\theta \Delta \theta_m - 57.3 \gamma_V \dot{V}_m + \gamma_q q_m + \gamma_{\delta_c} \delta_c$$

where

$$\gamma_z = \frac{-\bar{q} S}{m V_0} (C_{D_n} \sin \alpha_0 + C_{D_o} \cos \alpha_0 + C_{L_n} \cos \alpha_0 - C_{L_o} \sin \alpha_0)$$

$$\gamma_{\dot{z}} = \cos \alpha_0$$

$$\gamma_q = \cos \alpha_0$$

$$\gamma_\theta = \frac{-g \sin \theta_0}{V_0}$$

$$\gamma_V = \frac{\sin \alpha_0}{V_0}$$

$$\gamma_V = \frac{-\rho S}{m} (C_{L_o} \cos \alpha_0 + C_{D_o} \sin \alpha_0)$$

$$\gamma_{\delta_c} = \frac{-\bar{q} S}{m V_0} (C_{L_{\delta_c}} \cos \alpha_0)$$

c. Pitching moment equation with respect to the y body axis.

$$\dot{q}_m = m_q q_m + m_{\dot{z}} \dot{z}_m + m_\alpha \Delta \alpha_m + 57.3 m_V \Delta V_m + m_{\delta_c} \Delta \delta_c + 57.3 m_{\delta_T} \delta_T$$

where

$$m_q = \frac{\bar{q} S c}{I_y} \cdot \frac{c}{2V_0} C_{m_q}$$

$$m_{\dot{z}} = \frac{\bar{q} S c}{I_y} \cdot \frac{c}{2V_0} C_{m_{\dot{z}}}$$

$$m_\alpha = \frac{\bar{q} S c}{I_y} C_{m_\alpha}$$

$$m_V = \frac{\gamma_{r_c}}{I_y} \left[\left(\frac{\partial T}{\partial V} \right)_0 - \frac{2T_0}{V_0} \right]$$

$$m_{\delta_c} = \frac{\bar{q} S c}{I_y} C_{m_{\delta_c}}$$

$$m_{\delta_T} = \frac{\gamma_{r_c}}{I_y} \cdot \frac{\partial T}{\partial \delta_T}$$

LATERAL-DIRECTIONAL

The following data are also representative of the C-5A airplane as of April 1966 and though not used directly as in the case of longitudinal model following, were used to determine response time histories used to match the simulated time histories and to simulate the required lateral-directional modes. All derivatives are per radian, and are for the unaugmented configuration. The augmented configuration was developed by converting the gains of a Lockheed-Georgia augmentation system to equivalent artificial derivatives.

$I_{xx} = 17 \times 10^6 \text{ slug-ft}^2$	$C_{Y\beta} = .0765$
$I_{yy} = 39.2 \times 10^6 \text{ slug-ft}^2$	$C_{Yr} = -.154$
$I_{zz} = 1.31 \times 10^6 \text{ slug-ft}^2$	$C_{Y\dot{\phi}} = -.308$
$C_{Yp} = -.774$	$C_{Y\dot{\psi}} = .206$
$C_{Yq} = 0$	$C_{Y\dot{\chi}} = .0204$
$C_{Yr} = .466$	$C_{Y\dot{\delta}_r} = -.106$
$C_{Y\dot{\phi}} = -.123$	$C_{Y\dot{\delta}_\phi} = 0$
$C_{Y\dot{\psi}} = -.465$	$C_{Y\dot{\delta}_\psi} = -.045$
$C_{Y\dot{\chi}} = .456$	$C_{Y\dot{\delta}_\chi} = -.0052$

The following equations of motion were used.

$$\begin{aligned} \dot{\beta} - Y_{\beta} \beta + (1 - Y_r) r - \frac{g}{V} \phi - Y_{\delta_{AS}} \delta_{AS} + Y_{\delta_r} \delta_r \\ - L'_{\beta} \beta - L'_{r} r + \dot{\phi} - L'_{\dot{\phi}} \dot{\phi} = L'_{\delta_{AS}} \delta_{AS} + L'_{\delta_r} \delta_r \\ - N'_{\beta} \beta + \dot{r} - N'_{r} r - N'_{\dot{\phi}} \dot{\phi} = N'_{\delta_{AS}} \delta_{AS} + N'_{\delta_r} \delta_r \end{aligned}$$

Note that these are written in terms of "primed" derivatives which are defined generally as follows:

$$Y'_i = Y_i$$

$$L'_i = K \left(L_i + \frac{I_{xz}}{I_x} N_i \right)$$

$$N'_i = K \left(N_i + \frac{I_{xz}}{I_y} L_i \right)$$

where

$$K = \frac{1}{1 - \frac{I_{xz}^2}{I_x I_y}} \approx 1$$

and

$$Y_i = \frac{\partial Y}{\partial i} / mV$$

$$L_i = \frac{\partial L}{\partial i} / I_x$$

$$N_i = \frac{\partial N}{\partial i} / I_z$$

Note also that the rolling and yawing control inputs are in terms of control wheel deflections rather than control surface deflections. This was done so that the C-5A moments due to aileron and spoiler deflection could be combined and referred to a single control input; the aileron wheel.

Both L and N are nonlinear with δ_{AS} . However, for small disturbance validation purposes, the initial slope for $0 < \delta_{AS} < 5^\circ$ was used for the rolling moment. In flight the actual nonlinear function was used for each pb/2U. In the case of the yawing moment due to δ_{AS} a linear approximation was used for both the digital responses and in-flight simulation.

Values of those derivatives are given below, and are per radian.

pb/2U	$N'_{\delta_{AS}}$	$L'_{\delta_{AS}}$
.25	.0574	.689
.17	.0376	.517
.10	.0188	.346

**APPENDIX II
EVALUATION PILOT FLIGHT EXPERIENCE**

Pilot	Hours	Medium and Large Aircraft	Flight Testing		Operations	
	Total		Military	Commercial	Military	Commercial
A	7750	4300	0	3000	0	4750
B	4700	3100	0	3168	0	1532
C	3388	2744	1050	0	2237	689

Total hours one year preceding evaluation:

Pilot A: 385
Pilot B: 155
Pilot C: 581

Unclassified
Security Classification

DOCUMENT CONTROL DATA - R&D		
<small>(Security classification of title, body of abstract and indexing annotation must be entered when the overall report is classified)</small>		
1. ORIGINATOR'S ACTIVITY (Corporate name)		20. REPORT SECURITY CLASSIFICATION
Cornell Aeronautical Laboratory, Inc.		Unclassified
P. O. Box 235		21. GROUP
Buffalo, New York 14221		N/A
3. REPORT TITLE		
IN-FLIGHT SIMULATION AND PILOT EVALUATION OF SELECTED LANDING APPROACH HANDLING QUALITIES OF A LARGE LOGISTICS TRANSPORT AIRPLANE		
4. DESCRIPTIVE NOTES (Type of report and inclusive dates)		
Final Report		
5. AUTHOR(S) (Last name, first name, initial)		
Rhoads, Donald W.		
6. REPORT DATE	7a. TOTAL NO. OF PAGES	7b. NO. OF REFS
July 1967	72	7
8a. CONTRACT OR GRANT NO.	22. ORIGINATOR'S REPORT NUMBER(S)	
AF33(613)-3955	TB-2282-F-2	
a. PROJECT NO.	23. OTHER REPORT NO(S) (Any other numbers that may be assigned this report)	
8219	AFFDL TR 67-51	
b. Task No.		
821905		
c.		
10. AVAILABILITY/LIMITATION NOTICES		
This document is subject to special export controls and each transmittal to foreign governments or foreign nationals may be made only with prior approval of AFFDL (FDCC), Wright-Patterson AFB, Ohio 45433		
11. SUPPLEMENTARY NOTES	12. SPONSORING MILITARY ACTIVITY	
N/A	AFFDL (FDCC) Wright-Patterson AFB, Ohio 45433	
13. ABSTRACT A simulation program examined selected handling qualities of a large logistics transport airplane in the landing approach, considering both longitudinal and lateral-directional characteristics. A variable stability B-26 airplane was used as an in-flight simulator. The longitudinal short-period frequency and damping ratio and the stick force per normal acceleration were varied using a modal-following technique. The Dutch roll frequency and damping ratio, the amplitude of the bank angle to sideslip ratio (at the Dutch roll frequency) and the roll mode time constant were adjusted to simulate stability augmentation system on and off using the response-feedback technique. Lateral control was investigated with various amounts of maximum control power and two different amounts of control system time lag. The pilots performed general airwork and made ILS approaches, some with lateral offset. The landing flare and touchdown were not included in the evaluation. The results of this program are presented in terms of acceptability to the pilots, based upon a numerical rating and detailed comments. Three evaluation pilots participated. Regardless of longitudinal parameter variation, the majority of pilot evaluation data fell in the "acceptable but unsatisfactory" category. Most noted was the sluggishness in pitch (slightly improved in the augmented configuration) and high stick travel per incremental normal acceleration. Opinion was divided as to the relative desirability of the two values of stick force per incremental normal acceleration evaluated. Parameter variations in the lateral-directional evaluation yielded data which extended from the "acceptable but unsatisfactory" category to the "unflyable" category. Results were strongly influenced by the piloting difficulties associated with the changes (Continued)		

DD FORM 1473
1 JAN 64

Unclassified

Security Classification

14. KEY WORDS	LINK A		LINK B		LINK C	
	ROLE	WT	ROLE	WT	ROLE	WT
In-Flight simulation data Flight control system characteristics Aircraft Stability augmentation requirements Low speed landing approach						

INSTRUCTIONS

1. **ORIGINATING ACTIVITY:** Enter the name and address of the contractor, subcontractor, producer, Department of Defense activity or other organization (corporate address) issuing the report.
- 2a. **REPORT SECURITY CLASSIFICATION:** Enter the original security classification of the report. Indicate whether "Restricted Data" is included. Marking is to be in accordance with appropriate security regulations.
- 2b. **GROUP:** Automatic downgrading is specified in DoD Directive 5200.10 and Armed Forces Industrial Manual. Enter the group number. Also, when applicable, show that optional markings have been used for Group 3 and Group 4 as authorized.
3. **REPORT TITLE:** Enter the complete report title in all capital letters. Titles in all cases should be unclassified. If a meaningful title cannot be selected without classification, show title classification in all capitals in parenthesis immediately following the title.
4. **DESCRIPTIVE NOTES:** If appropriate, enter the type of report, e.g., interim, progress, summary, annual, or final. Give the inclusive dates when a specific reporting period is covered.
5. **AUTHOR(S):** Enter the name(s) of author(s) as shown on or in the report. Enter last name, first name, middle initial. If military, show rank and branch of service. The name of the principal author is an absolute minimum requirement.
6. **REPORT DATE:** Enter the date of the report as d./month/year, or month/year. If more than one date appears on the report, use date of publication.
- 7a. **TOTAL NUMBER OF PAGES:** The total page count should follow normal pagination procedures, i.e., enter the number of pages containing information.
- 7b. **NUMBER OF REFERENCES:** Enter the total number of references cited in the report.
- 8a. **CONTRACT OR GRANT NUMBER:** If appropriate, enter the applicable number of the contract or grant under which the report was written.
- 8b, 8c, & 8d. **PROJECT NUMBER:** Enter the appropriate military department identification, such as project number, subproject number, system numbers, task number, etc.
- 9a. **ORIGINATOR'S REPORT NUMBER(S):** Enter the official report number by which the document will be identified and controlled by the originating activity. This number must be unique to this report.
- 9b. **OTHER REPORT NUMBER(S):** If the report has been assigned any other report numbers (either by the originator or by the sponsor), also enter this number(s).
10. **AVAILABILITY/LIMITATION NOTICES:** Enter any limitations on further dissemination of the report, other than those

imposed by security classification, using standard statements such as:

- (1) "Qualified requesters may obtain copies of this report from DDC."
- (2) "Foreign announcement and dissemination of this report by DDC is not authorized."
- (3) "U. S. Government agencies may obtain copies of this report directly from DDC. Other qualified DDC users shall request through _____."
- (4) "U. S. military agencies may obtain copies of this report directly from DDC. Other qualified users shall request through _____."
- (5) "All distribution of this report is controlled. Qualified DDC users shall request through _____."

If the report has been furnished to the Office of Technical Services, Department of Commerce, for sale to the public, indicate this fact and enter the price, if known.

11. **SUPPLEMENTARY NOTE:** Use for additional explanatory notes.
12. **SPONSORING MILITARY ACTIVITY:** Enter the name of the departmental project office or laboratory sponsoring (paying for) the research and development. Include address.
13. **ABSTRACT:** Enter an abstract giving a brief and factual summary of the document indicative of the report, even though it may also appear elsewhere in the body of the technical report. If additional space is required, a continuation sheet shall be attached.

It is highly desirable that the abstract of classified reports be unclassified. Each paragraph of the abstract shall end with an indication of the military security classification of the information in the paragraph, represented as (TS), (S), (C), or (U).

There is no limitation on the length of the abstract. However, the suggested length is from 150 to 225 words.
14. **KEY WORDS:** Key words are technically meaningful terms or short phrases that characterize a report and may be used as index entries for cataloging the report. Key words must be selected so that no security classification is required. Identifiers such as equipment model designation, trade name, military project code name, geographic location, may be used as key words but will be followed by an indication of technical context. The assignment of links, roles, and weights is optional.

Unclassified

13. Abstract (Continued) in the rudder coordination requirements during turns. From the data obtained, it was difficult to specify minimum roll control requirements for this mission with assurance. Generally, a $\dot{\phi}/2U$ no greater than 0.2 and $\dot{\phi}$, no greater than 4° appeared sufficient for two of the evaluation pilots. The third pilot, however, desired larger values.

This abstract is subject to special export controls and each transmittal to foreign governments or foreign nationals may be made only with prior approval of AFDD (FDCC), Wright-Patterson AFB, Ohio 45433.

Unclassified