

UNCLASSIFIED

AD NUMBER

AD821162

LIMITATION CHANGES

TO:

Approved for public release; distribution is unlimited.

FROM:

Distribution authorized to U.S. Gov't. agencies only; Administrative/Operational Use; SEP 1967. Other requests shall be referred to Naval Electronic Systems Command, Washington, DC.

AUTHORITY

NESC ltr 7 Aug 1973

THIS PAGE IS UNCLASSIFIED

V

USE OF THE BEVERAGE ANTENNA IN WIDE APERTURE HIGH FREQUENCY DIRECTION FINDING

AD821169
AD821162

FINAL REPORT
VOLUME I-RESEARCH AND DEVELOPMENT

Paul E. Martin
Carl Dodge

Volume I of two volumes Final Development Report on SWRI Project 16-1380,
Contract N0ber-88346, Project Serial No. SF0018886, Task 9884 for Navy
Department, Naval Electronic Systems Command, Period Covered 3 June 1963
to 30 June 1967. Report date: 15 September 1967.



SOUTHWEST RESEARCH INSTITUTE
SAN ANTONIO **HOUSTON**

USE OF THE BEVERAGE ANTENNA IN WIDE APERTURE HIGH FREQUENCY DIRECTION FINDING

FINAL REPORT VOLUME I-RESEARCH AND DEVELOPMENT

Paul E. Martin
Carl Dodge

September 1967

Approved:



Douglas M. Travers, Director
Department of Applied Electromagnetics

STATEMENT #3 UNCLASSIFIED

Each transmittal of this document outside the agencies of the
U.S. Government must have prior approval of *Naval Ship Engg. Center*
Code 6176-B-021 Wash D C.

Volume I of two volumes Final Development Report on SwRI Project 16-1360,
Contract N0bar-89345, Project Serial No. SF0010805, Task 9094 for Navy
Department, Naval Electronic Systems Command, Period Covered 3 June 1963
to 30 June 1967. Report date: 15 September 1967.

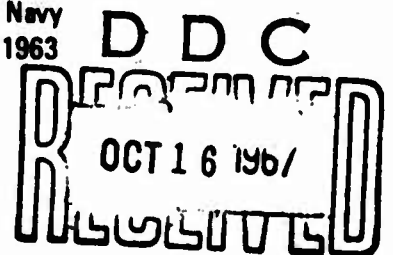

FOREWORD

Both theoretical and experimental research at SwRI since 1961 have shown that the Beverage antenna is quite useful throughout the entire high frequency band and over soils of relatively high conductivity. It has also been shown that the antenna is within that class of antennas often described as frequency independent with an endfire unidirectional radiation pattern that is aperiodically maintained throughout the 1 to 30-MHz frequency range. Furthermore, it is particularly useful as a low cost element for circular wide aperture high frequency direction finding arrays.

Contract NObsr-89345 between the Navy Department Electronics System Command and SwRI became effective 3 June 1963. The contract as modified terminated 30 June 1967. Detailed results of specific areas of research concerning the use of the Beverage antenna in wide aperture high frequency radio direction finding have been presented in a series of contract technical reports (Quarterly interim reports 1-14).

Initially, funding support was provided by the U. S. Navy; however, in October 1965, the contract was modified to include support by the U. S. Army. The research objectives were expanded to meet the special requirements of the U. S. Army which were initiated under a separate contract DA 36-039-AMC 02346(E), July 1963 through June 1964.

For those interested in detailed discussions of the research program, the work is summarized in specific interim reports (see References 1 through 6 of List of References this report) and this the final report under Contract NObsr-89345 which is divided into two volumes: Volume I describing the research and development and Volume II describing bearing accuracy tests.

The engineering assistance of D. N. Travers, Dr. G. B. Walker, C. Dodge, W. M. Sherrill, R. Lorenz, M. P. Castles, T. C. Green, R. B. Wangler, S. H. Hixon, and D. R. Saathoff during the life of this contract is acknowledged.

ABSTRACT

Four years of research and development concerning the use of the Beverage antenna for high frequency radio direction finding are summarized in this two-volume final report. Volume I concerns all design details. Bearing accuracy tests on several configurations of circular arrays of 75-meter long elements are described in Volume II.

A computer programmed general theory of the Beverage antenna has been completed to calculate azimuth and elevation element and array patterns as a function of antenna length, height above ground, array size, frequency, earth constants, phasing and many other parameters. Verifying experimental measurements are also reported.

The development of a Wullenweber-type scan digital commutator to permit extreme flexibility in arraying of any number of Beverage antennas with any array spacing has been completed. The present digital commutator design has demonstrated reduction in switching transients below system noise levels, good element to element isolation, satisfactory gain in each antenna circuit, and predicted array gains. Design details for an electronic digital commutator (no rotating parts) have been completed. The present design is a suitable basis for control and programming by digital computer in a real time adaptive system.

Research results have shown the value of Beverage antennas as a low cost element in wideband circular wide aperture HF DF arrays over soils of relatively either low or high conductivity. The antenna is essentially frequency independent with an endfire unidirectional aperiodic pattern throughout the 1 to 30-MHz range. The input impedance, almost totally resistive and uniformly flat over the frequency range of interest, can be easily transformed to any standard feed cable impedance with a standing wave ratio of less than 1.25/1. Antenna dimensions need not exceed one wavelength long or one meter above ground. For a fixed size array, reduced beamwidth and increased sensitivity is obtained with short antennas and a large feedpoint radius rather than long antennas with a short feedpoint radius.

Evaluation of the antenna in direction finder performance using circular arrays including simultaneous comparison with an AN/TRD-15 Doppler system is reported. Bearing accuracy tests show performance comparable to the AN/TRD-15 in that, at times, one system then the other exhibited more favorable accuracy performance. Standard deviations obtained in certain samples were below 2°, but most were in the range of 2° to 3° with a few higher consistent with previous reporting. DF bearing sensitivities exceed that of the AN/TRD-15.

Delivery of the developed transportable Beverage direction finder to the U. S. Army including instruction and maintenance manual is reported.

TABLE OF CONTENTS

	<u>Page</u>
LIST OF ILLUSTRATIONS	vi
LIST OF TABLES	viii
I. PURPOSE	1
II. INTRODUCTION	2
III. RESEARCH ACTIVITIES	4
A. Development of a General Theory for the Beverage Antenna	4
B. Theoretical and Measured Antenna Parameters	6
C. Beverage Antenna Array Configurations	15
D. Instrumentation	16
1. Commutation	16
2. Receivers and Indicators	27
3. The AN/TRD-15 Doppler	34
E. Sensitivity Measurements	34
1. Single Element Sensitivity Measurement	37
2. Array Sensitivity	37
3. Array Gain	41
F. Antenna Patterns	41
1. Theoretical Antenna Patterns	41
2. Experimental Patterns	43
3. Difference Patterns	43
4. Sampling at the Array Periphery	46
5. Array Beamwidths	47
6. Effect of Reducing Number of Array Elements	51
7. Phased Arrays	51

TABLE OF CONTENTS (Cont'd)

	<u>Page</u>
G. Performance Tests -- Beverage and Doppler Systems	53
1. Bearing Accuracy	53
2. Bearing Sensitivity	53
3. High Angle Tests	55
H. Procedure for Beverage Antenna Design for HF DF	56
I. The Beverage Antennas As a Transmitting Antenna	58
J. AN/TRD-15 Site Error	58
IV. CONCLUSIONS	60
V. RECOMMENDATIONS	65
VI. LIST OF REFERENCES	66
APPENDIXES	
I. Instruction Manual for Transportable Direction Finder Set Using a Circular Array of Beverage Antennas (2-30 Mc)	I-1
II. Abstracts of Reports Concerning Beverage Antenna Research at Southwest Research Institute	II-1
III. Digital Program for Calculation of Great Circle Bearing and Distance Between Target and DF Site	III-1
IV. Bearing Error Statistics Program for Digital Computer	IV-1

DD FORM 1473

LIST OF ILLUSTRATIONS

<u>Figure</u>		<u>Page</u>
1	Circular Array of Beverage Antennas	5
2	Calculated and Measured Attenuation Constants for a Single Beverage Antenna at Several Heights Above Ground	7
3	Velocity Ratio of a Single Beverage Antenna vs Frequency as a Function of Various Heights Above Ground	8
4	Impedance vs Frequency of Single Beverage Antenna	9
5	Test Circuit for Swept Frequency VSWR Measurements	11
6	VSWR at Antenna Terminals vs Frequency	13
7	Impedance vs Frequency of Same Antenna of Figure 4, But with Matching Transformer	14
8	Site Locations of 112, 300 and 27-Meter Arrays	17
9	Site Locations of Concentric 75-Meter Arrays	18
10	AN/TRD-15 Doppler Array Installation	19
11	Partial Plan of Concentric Arrays	20
12	Cross Section of One Antenna Radial	21
13	Circuits for One Commutator Stage	24
14	30-Stage Module of Mark III Commutator - Front View	25
15	30-Stage Module of Mark III Commutator - Rear View	26

LIST OF ILLUSTRATIONS (Cont'd)

<u>Figure</u>		<u>Page</u>
16	Optical Generator Chassis	28
17	Master Control Chassis for Mark III Commutator - Front View	29
18	Master Control Chassis for Mark III Commutator - Rear View	30
19	Modules Grouped for 180-Stage Digital Commutator	31
20	Simplified Diagram of Dual Commutation System	32
21	DF Instrumentation Layout	33
22	Amplifiers for Remote Display of Doppler Pattern	35
23	Instrumentation for Sensitivity Measurement	36
24	Single Element Sensitivity	38
25	Array Sensitivity	39
26	Sensitivity Degradation Due to Commutator	40
27	Signal Gain vs Number of Elements in Array	40
28	Theoretical and Experimental Array Patterns	42
29	Patterns Describing Max and Null Mode Operation	44
30	Typical Null Patterns	45
31	Method of Commutating a Single Antenna for Two Directions 180° Apart	47
32	Measured Beamwidths vs Frequency - 75-Meter Array	48

LIST OF ILLUSTRATIONS (Cont'd)

<u>Figure</u>		<u>Page</u>
33	Measured Beamwidth vs Frequency - 112-Meter Array	49
34	Theoretical Beamwidths vs Frequency and Array Radius - 15 Antennas	50
35	Optimally Phased Array Pattern at 10 MHz - 21 Antennas	52
36	Nonoptimally Phased Array Pattern with One Delay at 10 MHz - 21 Antennas	52
37	AN/TRD-15 Bearing Error vs Frequency for Groundwave at Four Azimuths	59

LIST OF TABLES

<u>Table</u>		<u>Page</u>
I	Beverage-Doppler Bearing Sensitivity Tests	54

I. PURPOSE

Prior investigation by SwRI with experimental Beverage arrays has demonstrated the feasibility of design construction and operation of a low cost DF system which appears to have a bearing accuracy comparable to that obtainable with more costly wide aperture systems. It is the purpose of this research contract to develop an experimental land based wide aperture high frequency radio direction finding system using Beverage antennas to the point of outlining the design of a prototype system. It is the further objective of the program to design, develop, fabricate and furnish an experimental model of a Beverage DF and intercept system in sufficiently complete form (including instruction and maintenance manuals and spare parts) to permit operational evaluation under field conditions.

II. INTRODUCTION

Contract NObsr-89345 has been concerned with research and development on the use of the Beverage antenna in wide aperture land based high frequency radio direction finding. The work was a continuation of the research activities begun under Contracts NObsr-85364 and DA 36-039-AMC-02346(E).

The primary research objectives under Contract NObsr-89345 have been:

- (1) Develop a general theory of the Beverage antenna suitable for making design calculations by digital computer.
- (2) Calculate antenna and array response patterns in both azimuth and elevation planes by digital computer.
- (3) Continue the development and testing of improved commutation techniques.
- (4) Conduct and evaluate the performance of single Beverage antenna elements and arrays of elements in terms of impedance, sensitivity and direction finder patterns as a function of various parameters such as antenna length and height above ground, array size (not to exceed a 400-meter diameter), feed point location, and frequency.
- (5) Conduct bearing accuracy measurements to evaluate direction finder performance as a function of the parameters noted in Item(4). Measurements to include data to show the relative performance of the Beverage direction finder and the AN/TRD-15 Doppler direction finder.
- (6) Design, develop, fabricate and furnish a transportable experimental model of a Beverage direction finder and intercept system in sufficiently complete form, including instruction and maintenance manuals and spare parts, to permit operational evaluation of developmental findings under field conditions.

The detailed research tasks outlined in the contract statement as modified and performed over the life of the contract can be placed in one or more of the above categories. The results of many of these tasks have

been reported in specific interim reports and therefore will be summarized in this the final report only to the extent of providing a background to those areas of research not heretofore reported in detail.* Whenever appropriate, references will be made to a specific interim report that describes a given research task in detail.

The major tasks to be reported are within Items (4), (5), and (6) for 75-meter long Beverage elements. Details of the experimental model [Item (6)] are discussed in an instruction manual for the transportable system reproduced in its entirety in Appendix I.

*Abstracts of all interim reports for Contracts NObsr-85364, NObsr-89345, and DA 36-039-AMC-02346(E) are included in Appendix II.

III. RESEARCH ACTIVITIES

A. Development of a General Theory for the Beverage Antenna

The theoretical analysis has evolved from simple equations suitable for hand calculations through several digital computer programs, each allowing more parameter variations than its predecessor until the present program that permits the use of any number of elements to be summed or phased under a variety of assumed array geometries.

The detailed general analysis and digital computer program for deriving the dimensions of optimum circular arrays of Beverage antennas for HFDF were reported in March 1964 [4]. Modification of the Beverage array equations to enable the calculation of element or array patterns for antenna feed points located at either end of an element (inner or outer feeds) and array patterns obtained by combinations of inner and outer feed points was reported in December 1964 [7]*.

The analysis provides both groundwave and skywave patterns. For skywave patterns, the polarization of the incident field may be linear or elliptical (any condition between vertical and horizontal polarization). The procedure was to assume independent ground and skywave components arriving at the same azimuth. The skywave component includes both vertical and horizontal polarization components which may be specified independently. The total field strength for direct and reflected arrays is calculated at a point on the antenna wire with phase referred to the origin. The earth constants and exact reflection coefficients for the earth for both polarizations are retained in the calculation for skywaves.

Equations are derived for azimuth and elevation patterns for any number of identical antennas in a circular array of the general form shown in Figure 1. Any number of antennas may be considered spaced in any manner and summed in any arbitrary manner with or without phasing. The antennas may be of any length and any height above ground and any array size. The analysis also provides the calculation of antenna impedance, antenna line constants, effective height and wave tilt angle. It is also

*The present digital computer program BEVARRAY-II(E) is written for the GE225 digital computer. Memory limitations permit the summation of no more than 11 input pairs (phased or nonphased). However, a new program BEVANT-I, written in Fortran IV, permitting the computation of any array configuration, has been completed but not completely debugged at this time.

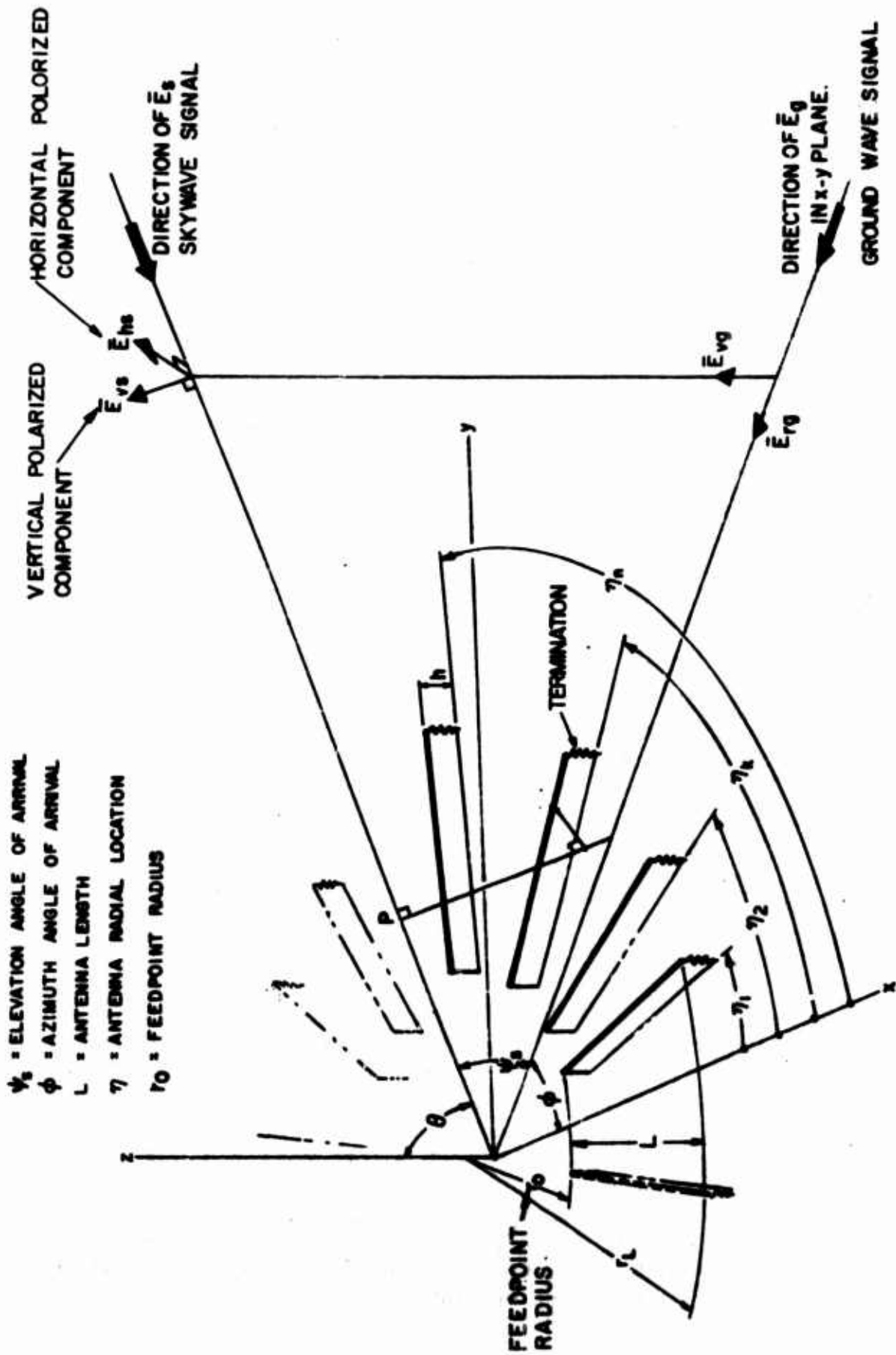

- ψ_s = ELEVATION ANGLE OF ARRIVAL
- ϕ = AZIMUTH ANGLE OF ARRIVAL
- L = ANTENNA LENGTH
- r_0 = ANTENNA RADIAL LOCATION
- r_0 = FEEDPOINT RADIUS

FIGURE 1. CIRCULAR ARRAY OF BEVERAGE ANTENNAS

possible to use experimentally measured values of these parameters in the pattern calculations.

The principal variables are the number of antennas, the manner of summing, and phasing, antenna spacing geometry, antenna location, overall array size, antenna length and height above ground, earth conductivity and dielectric constant, frequency and polarization of the incident signal.

The theoretical equations are quite general in the high frequency range, the only significant limitations (caused by mathematical difficulties) being neglect of mismatch in the termination impedance, and the necessity of assuming an average or high earth conductivity in order to obtain accurate results.

B. Theoretical and Measured Antenna Parameters

Most theoretical calculations and experimental measurements of Beverage antenna performance have been presented at intervals in past reports [2,5,8]. The antenna characteristics and terminal impedance of a single Beverage antenna have been experimentally measured by three techniques:

- (1) Admittance bridge on an open and short circuited transmission line.
- (2) Admittance bridge at the antenna terminals with the line resistively terminated in its characteristic impedance at the far end.
- (3) Swept frequency VSWR measurements through an impedance transformer at the antenna terminals with the antenna resistively terminated at the far end.

The theoretical and experimental effects of changes in antenna length, height above ground, and ground conductivity (as a function of frequency) on various Beverage antenna parameters are shown again in Figures 2 through 4. The measured attenuation constants and velocity ratios of Figures 2 and 3 were calculated from open and short circuit admittance measurements, while the input impedance of Figure 4 was calculated from measurements by the second technique. The theoretical attenuation constants, velocity ratios (ratio of the velocity of propagation on the Beverage wire to wave propagation velocity in free space) and impedance were calculated for measured values of ground conductivity ($\sigma = 0.03$ mho/meter) and dielectric constant ($\epsilon = 12$) found at Southwest Research Institute.

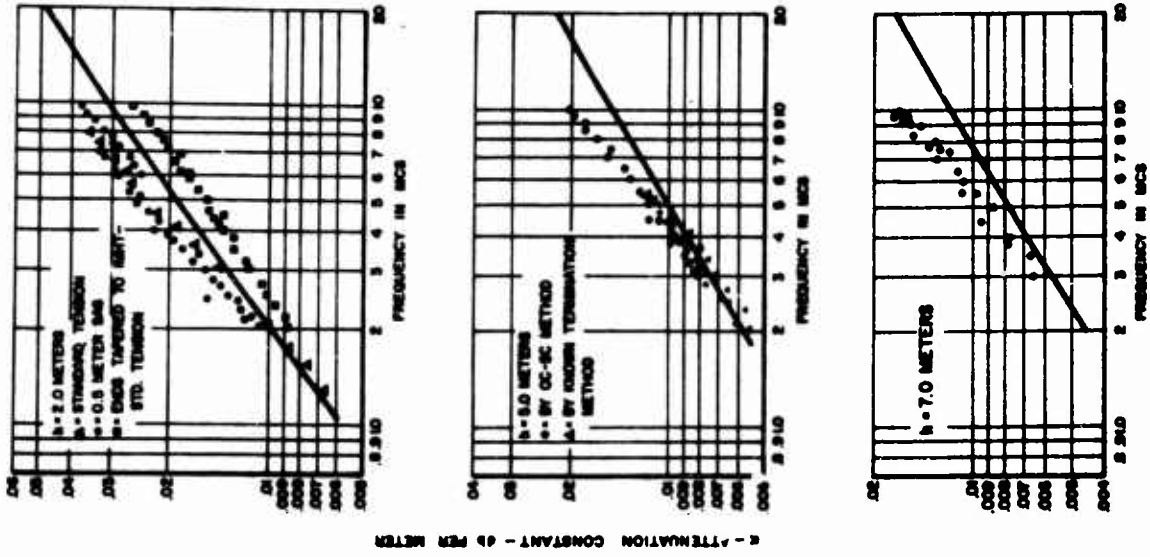

4 - ATTENUATION CONSTANT - dB PER METER

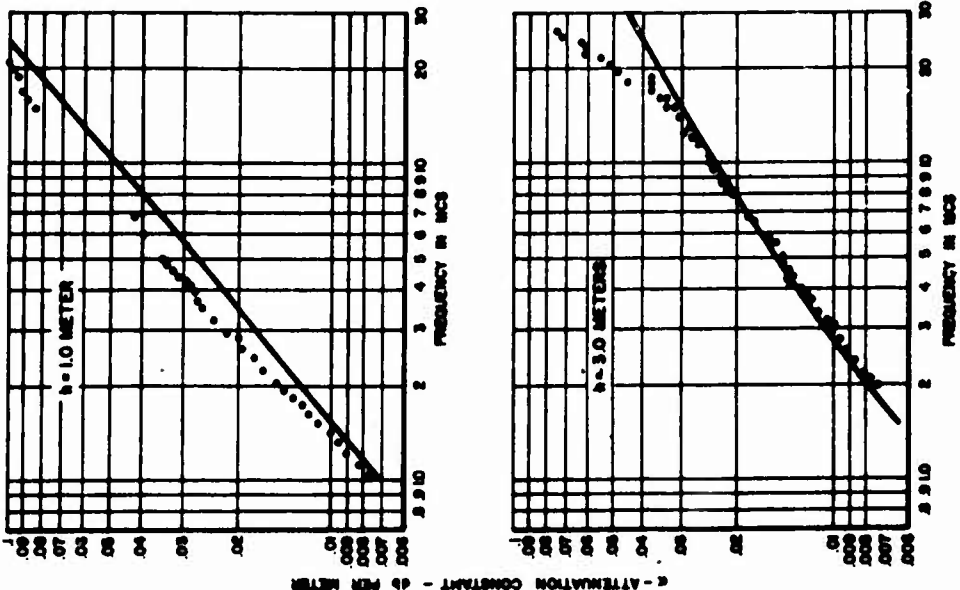

4 - ATTENUATION CONSTANT - dB PER METER

NOTE: SOLID LINES ON EACH GRAPH REPRESENT THE CALCULATED VALUES OF ϵ FOR $\sigma = 0.05$ MHO/MTR $\epsilon = 1.2$

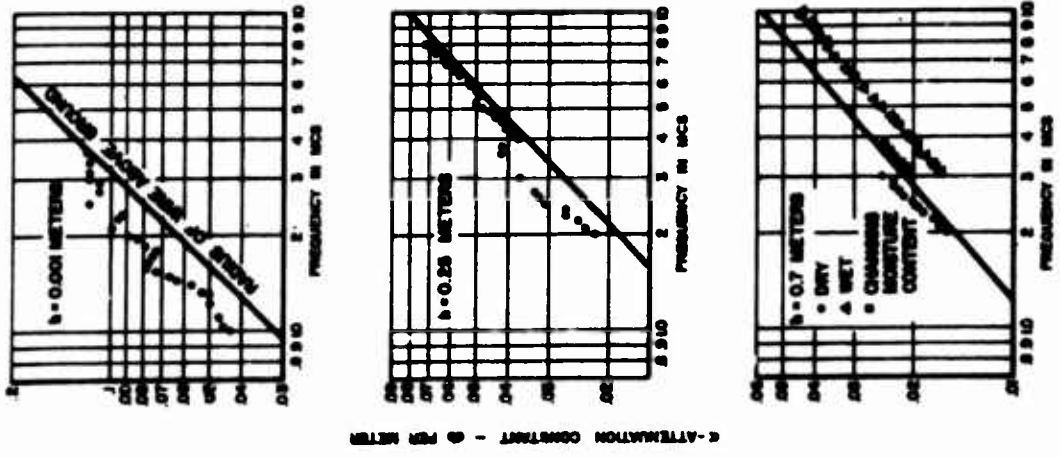

4 - ATTENUATION CONSTANT - dB PER METER

FIGURE 2. CALCULATED AND MEASURED ATTENUATION CONSTANTS FOR A SINGLE BEVERAGE ANTENNA AT SEVERAL HEIGHTS ABOVE GROUND

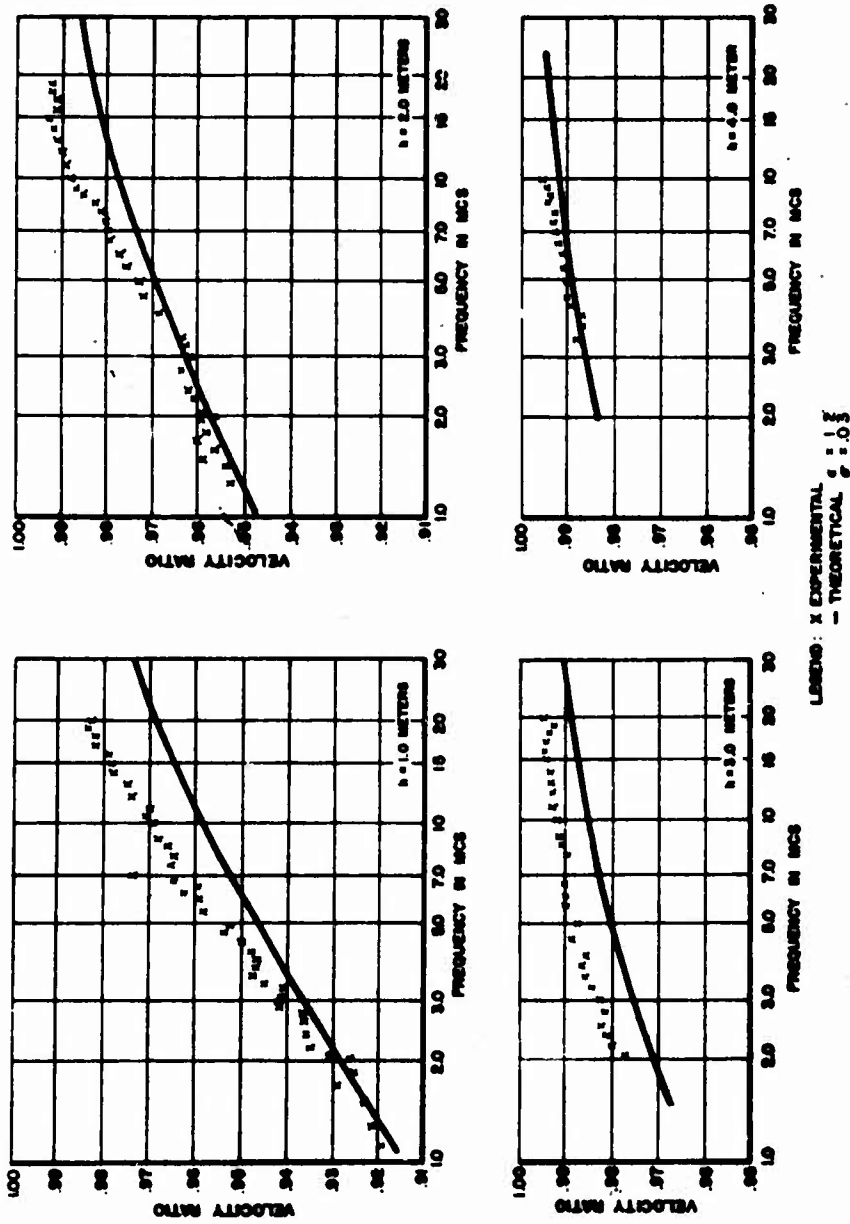

FIGURE 3. VELOCITY RATIO OF A SINGLE BEVERAGE ANTENNA VS
 FREQUENCY AS A FUNCTION OF VARIOUS HEIGHTS
 ABOVE GROUND

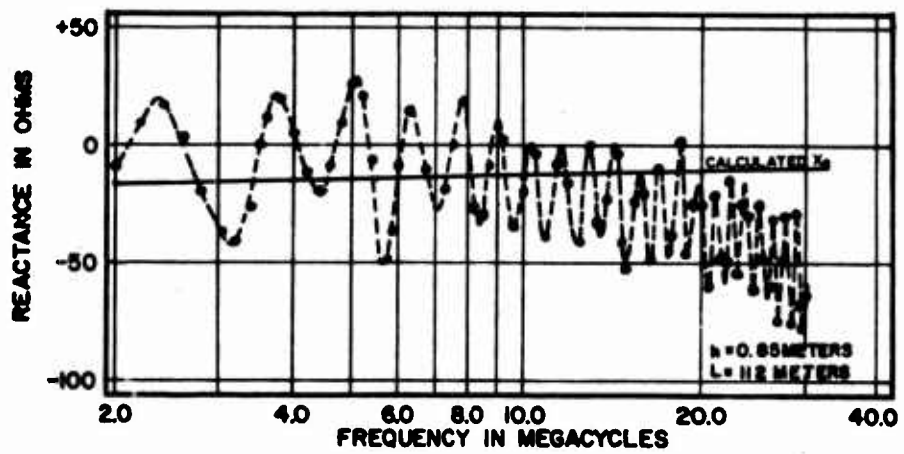
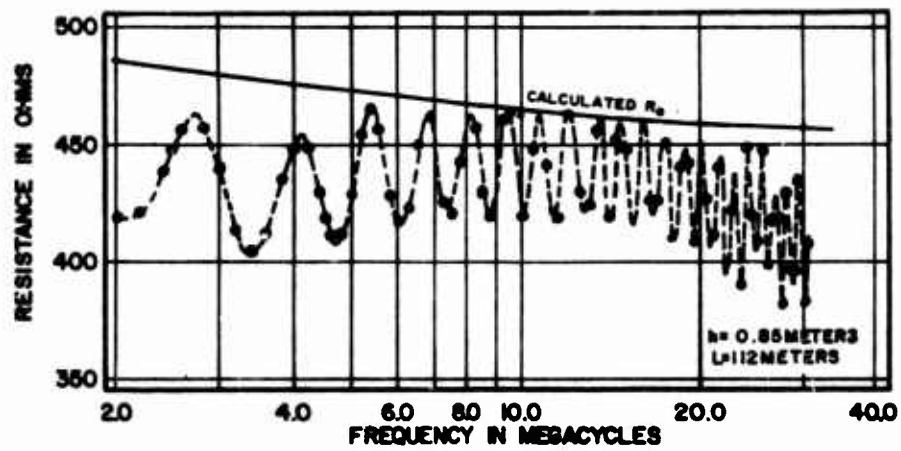

FIGURE 4. IMPEDANCE VS FREQUENCY OF SINGLE BEVERAGE ANTENNA

The VSWR technique is by far a more convenient method to apply. Useful results are immediately available at time of testing, whereas the first two methods require extensive and time-consuming data reduction before meaningful data are available. For example, to measure the terminal impedance of an antenna in sufficient detail from 1 to 30 MHz requires a minimum of 120 separate measurements with an admittance bridge such as the Wayne-Kerr B801. For each measurement, the frequency must be changed, the detector and receiver tuned to the new frequency, and the bridge rebalanced to some initial condition (open or short circuit terminals). The time consumed is about 6 to 8 hours of measurement and 2 to 3 days of data reduction and plotting.* On the other hand, VSWR measurements can be made over the frequency range of 1 to 30 MHz in less than 5 minutes per antenna and is very useful when installing, testing, or troubleshooting an array.

The point-by-point measurements are primarily useful when one is attempting to measure antenna or earth parameters by comparison of accurate experimental measurements to theoretical calculations (see Figure 2, for example).

The test setup for VSWR measurements is shown in Figure 5.† Measurements are made by the substitution method whereby the bridge is initially checked by connecting identical resistive standard loads (50 ohms) to each side of the bridge. Under these conditions, the bridge is balanced, and no voltage is available at detector terminals. Next, the 50-ohm load is removed from the unknown side of the bridge and replaced by calibrated but resistive mismatches that produce a known VSWR relative to the 50-ohm standard and, because of the wide band response, a constant level DC output as a function of frequency. The larger the VSWR, the greater the detector output. Since the results are usually displayed on an oscilloscope, the CRT display can be calibrated in VSWR relative to 50 ohms and as a function of frequency. Following calibration, the antenna is connected to the unknown side (usually through a high pass filter that reduces interference from local broadcast stations). The response as a function of

*New instruments are recently available such as the Hewlett-Packard vector impedance meter that can significantly reduce the time required. Data are available in impedance magnitude and phase angle.

†On the surface, the results appear qualitative rather than quantitative. However, careful observation of technique and subsequent study of the results will enable the calculation of attenuation and velocity ratio, as well as the characteristic impedance as a function of frequency.

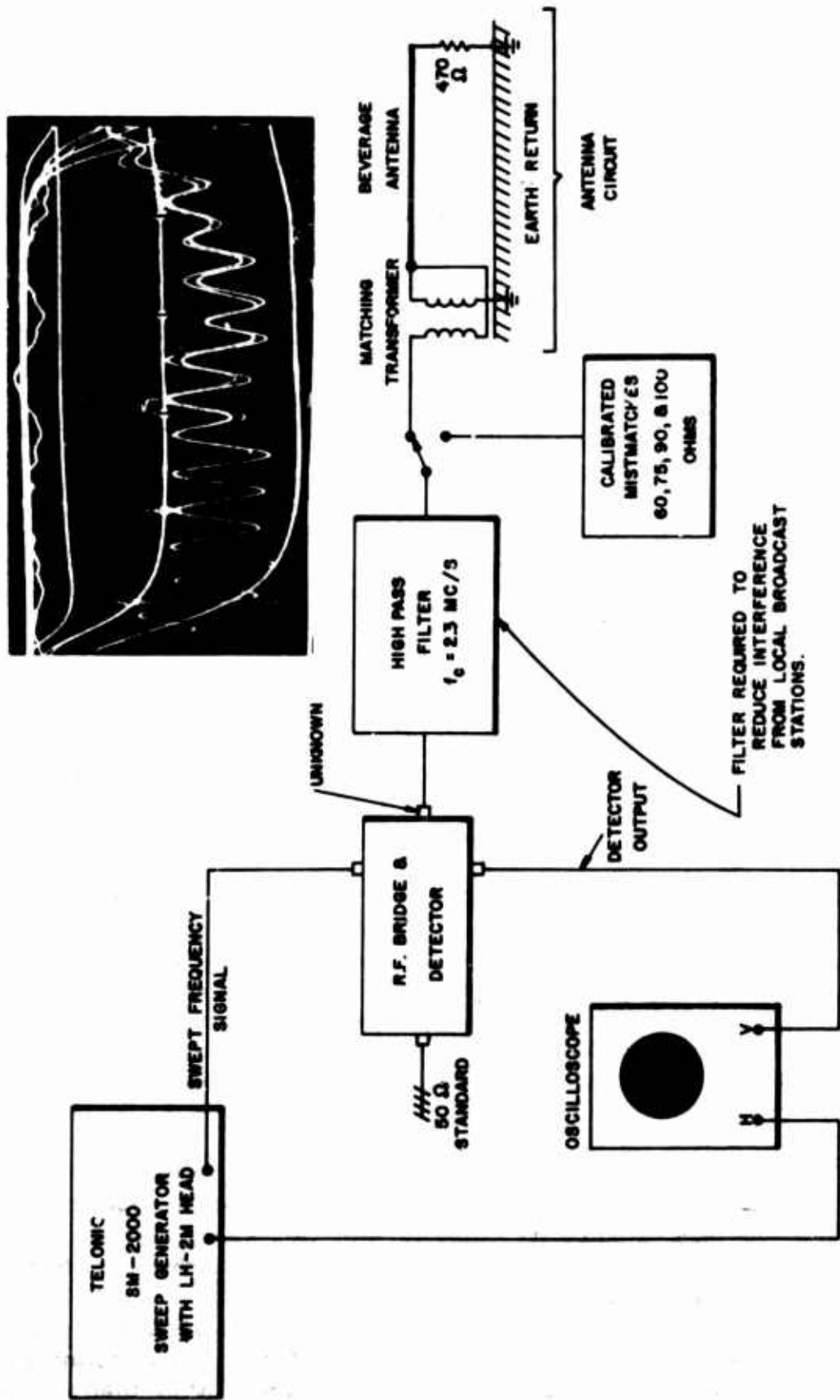

FIGURE 5. TEST CIRCUIT FOR SWEEPED FREQUENCY VSWR MEASUREMENTS

frequency can be directly compared to that from the known mismatches by multiple exposure photographs of the CRT display.*

Representative samples of the SVWR as a function of frequency at the antenna terminals are shown in Figure 6 for three antenna lengths and three antenna heights above ground. Although the results shown are based upon 50-ohm reference, the design feedpoint impedance for the Beverage system is 75 ohms. The calibration line marked 75 ohms in the figures was obtained by using a 1.5 calibrated mismatch relative to 50 ohms. Likewise, the 60-ohm line is a 1.2 mismatch and the 90-ohm line a 1.8 mismatch. It can be seen that when the antenna is substituted for the known mismatches that the terminal impedance is not less than 60 ohms nor more than 90 ohms over the frequency range except when the antenna is placed directly on the ground. †

When the VSWR measurements are transposed to a 75-ohm reference, the $Z = 60$ -ohm line represents a VSWR of 1.25/1, and $Z = 90$ -ohm line represents a VSWR of 1.20/1 referred to 75 ohms. Thus, it can be seen that the VSWR never exceeds 1.25/1 over the frequency range of 3 to 30 MHz.

Note that if a 75-ohm standard was used on the reference side of the bridge, one could not determine when the input impedance became less than 75 ohms since the detector only indicates the absolute value of the mismatch relative to the reference standard. By using a 50-ohm reference, however, the variations in line impedance can be easily determined.

Representative impedance measurements through an impedance transformer (a four-turn bifilar wound matching transformer) by the admittance bridge method are shown in Figure 7 for an antenna having a characteristic impedance of Figure 4. It can be seen that the resistive term of the input impedance varies between 77 and 65 ohms over the frequency range of 2.5 to 30 MHz, while the reactive term is slightly inductive. A subsequent calculation will show that when a 75-ohm feed cable is used the VSWR is within 1.15/1 over the entire frequency range.

*Details of the filter and impedance matching transformer between the bridge circuit and the antenna shown in Figure 5 are described in Appendix I (pp. I-23 through I-31) along with other termination specifications. Note also that the filter becomes part of the bridge circuit so that the characteristics of the antenna only can be determined.

†It is also possible that the antenna and impedance could always be less than 50 ohms and produce the same VSWR as shown. However, any ambiguity can be (and was) resolved by using a second reference other than 50 ohms, say 40 ohms, and noting whether the VSWR increases or decreases.

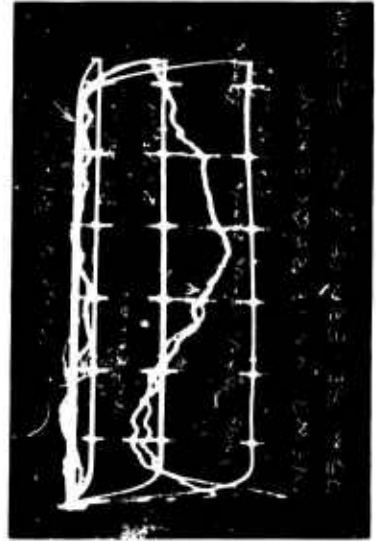

75 Meter Beverage Elements

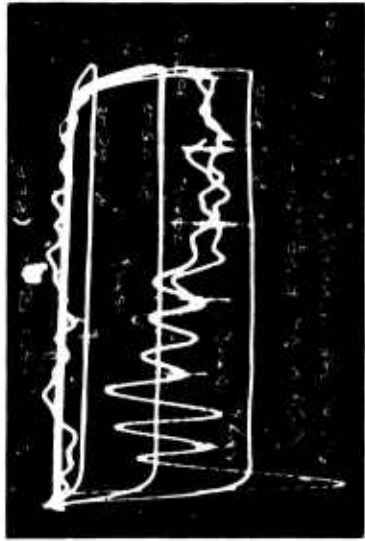

50 Meter Beverage Elements

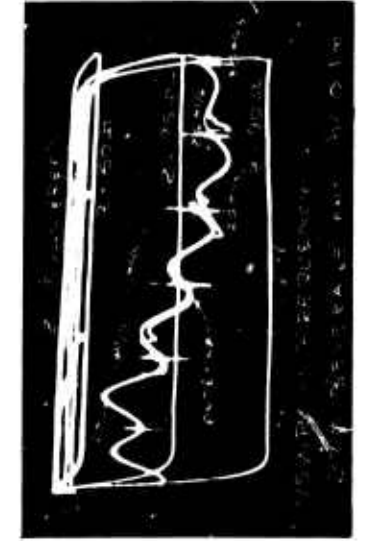
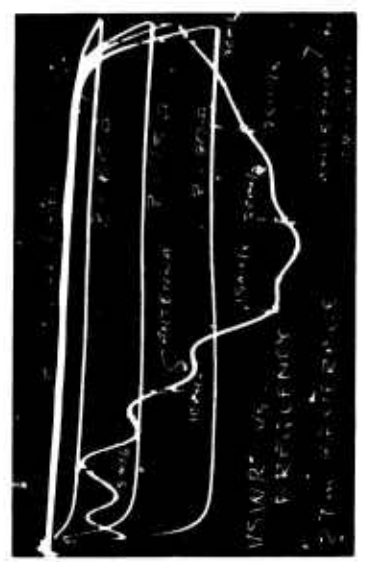

27 Meter Beverage Elements

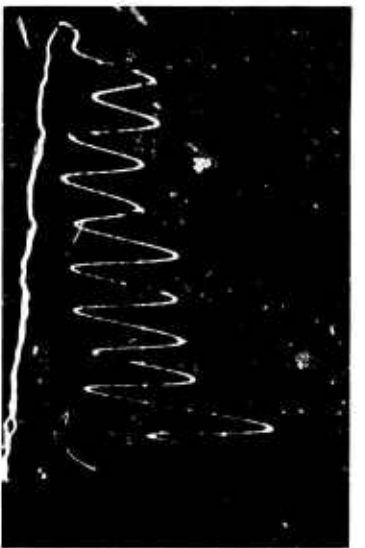
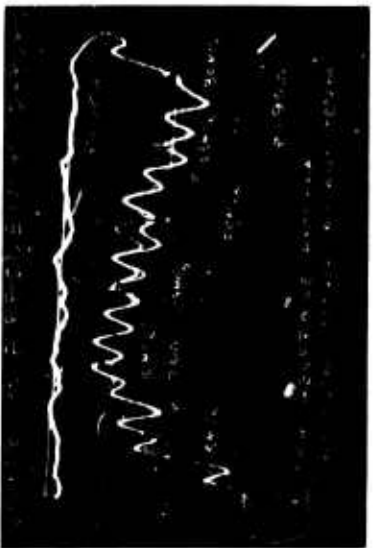

FIGURE 6. VSWR AT ANTENNA TERMINALS VS FREQUENCY

ANTENNA CIRCUIT AS SHOWN IN FIGURE 5.

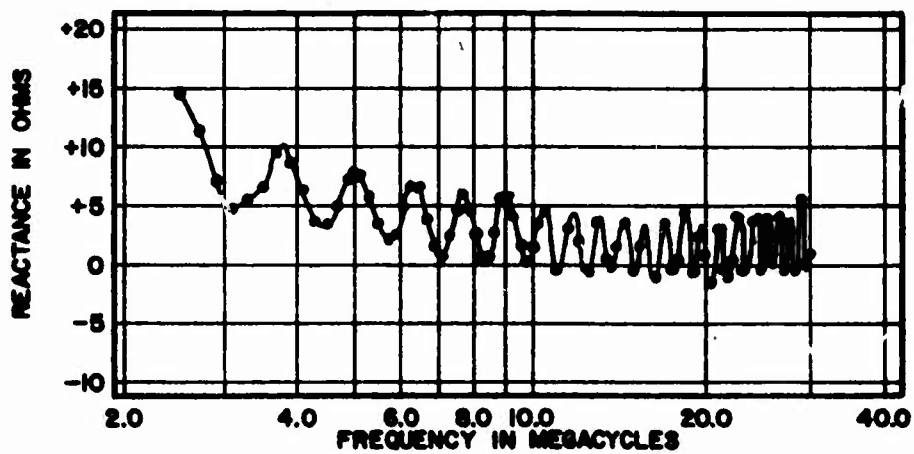
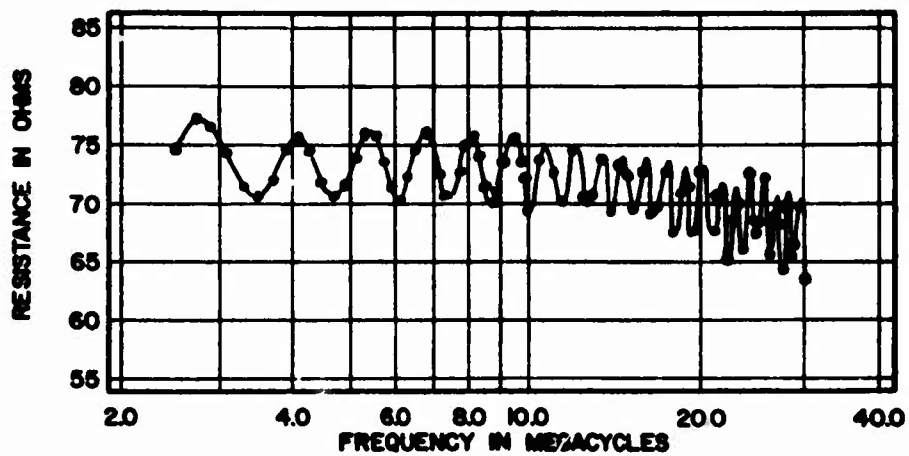

FIGURE 7. IMPEDANCE VS FREQUENCY OF SAME ANTENNA OF FIGURE 4, BUT WITH MATCHING TRANSFORMER

These tests demonstrate that the antenna is effectively terminated over the frequency range of 1 to 30 MHz and that no discontinuity or resonances occur even though each antenna becomes several wavelengths long at 30 MHz. The aperiodic characteristic is an important characteristic that can be used to advantage in the design and operation of antenna filters, multicouplers, power dividers, and commutators. It means that circuits can be tested in the laboratory with conventional test instruments (having 50 or 75-ohm output impedances) with assurance that the results will be meaningful when the test generator is replaced by the antenna circuit.

C. Beverage Antenna Array Configurations

During the contract period, the performance of several Beverage Antenna Array Configurations were studied. In all instances, the antenna array was made up of 180 antenna elements radially spaced every 2° azimuth. Array names and specifications are given below. The year in which the tests were conducted are shown in parentheses; for the early work, references are made to previous reports describing the performance:

- (1) 112-meter array - antenna length height 112 meters, feedpoint radius - 25 meters, termination radius height - 137 meters, antenna length height above ground - 0.85 meter (1964, 1964) [2, 3].
- (2) 300-meter array - antenna length - 300 meters, feedpoint radius - 25 meters, termination radius - 325 meters, antenna height above ground - 1.0 meter (1964) [5].
- (3) 27-meter array - antenna length - 27 meters, feedpoint radius - 109 meters, termination radius - 136 meters, antenna length above ground - 0.7 meter (1964) [5].
- (4) Array A-I (1.0) - antenna length - 75 meters, feedpoint radius - 46 meters, termination radius - 121 meters, height above ground - 1.0 meter (1966).
- (5) Array A-II (1.0) - antenna length - 75 meters, feedpoint radius - 131 meters, termination radius - 206 meters, height above ground - 1.0 meter (1966).
- (6) Array A-II (0.1) - antenna length - 75 meters, feedpoint radius - 131 meters, termination radius - 206 meters, height above ground - 0.1 meter (1966-1967).

- (7) Array A-I (0.25) - antenna length - 75 meters, feedpoint radius - 46 meters, termination radius - 121 meters, height above ground - 0.25 meter (1967).

Relative locations of the 112-meter and 300-meter Beverage array are shown in the field site map of Figure 8. The 27-meter array was constructed on the 112-meter site by maintaining a constant outer radius for the array and increasing feedpoint radius to 109 meters (112-meter array dismantled).

The site locations for the 75-meter Beverage arrays A-I and A-II and the AN/TRD-15 Doppler DF (see Introduction) are shown in Figure 9. A photograph of the AN/TRD-15 Doppler array is shown in Figure 10. (The 300-meter array was dismantled to enable installation of the two 75-meter arrays.)

Note that arrays A-I and A-II are concentric with specific elements in each array along the same radial. A partial plan of the concentric arrays is shown on Figure 11. Provisions to commutate both ends of each antenna and cross section along one radial are shown in Figure 12.

D. Instrumentation

1. Commutation

The commutator is perhaps the most important item in the instrumentation of any wide aperture, multielement antenna array.* In the Beverage system, the function of the commutator is to sample the inputs from an array of circularly disposed elements and to provide a means whereby the amplitude and/or phase of the sample signal can be displayed in synchronism with a circular (sine-cosine) sweep applied to a cathode ray tube. The objective is to display a synthesized antenna pattern, based upon the assumption that all the elements have identical response at all frequencies in both horizontal and vertical planes, that can be used to accurately determine the azimuthal angle of arrival of a radio signal.

Digital commutator design considered the following specifications†:

- (1) Commutate through 360°, a beam formed by the summation of any number of antennas with any desired separation between antennas.

*See additional discussion in Section III, F. 7.

†Sometimes referred to in the literature as electronic goniometer.

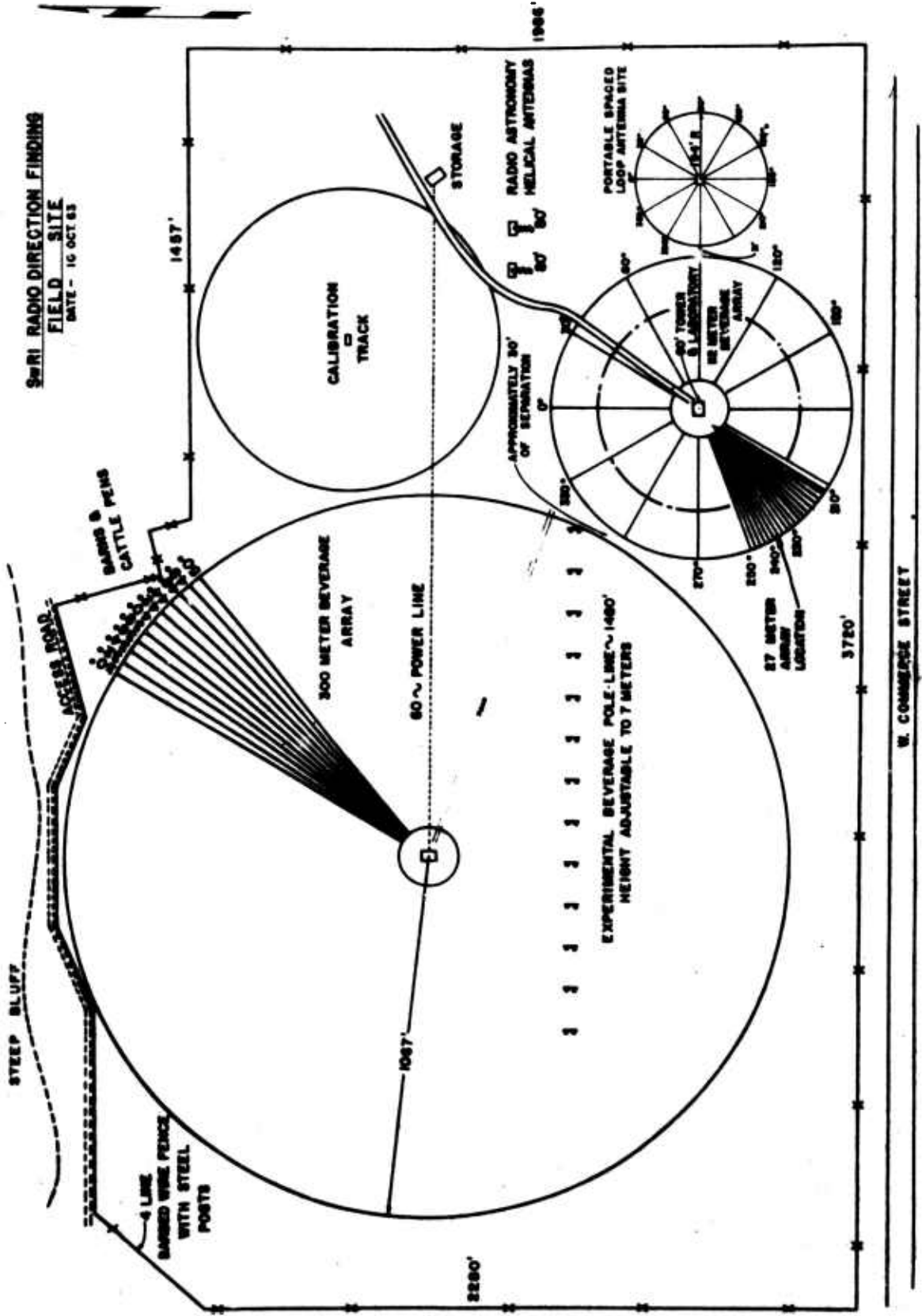

FIGURE 8. SITE LOCATIONS OF 112, 300 AND 27-METER ARRAYS

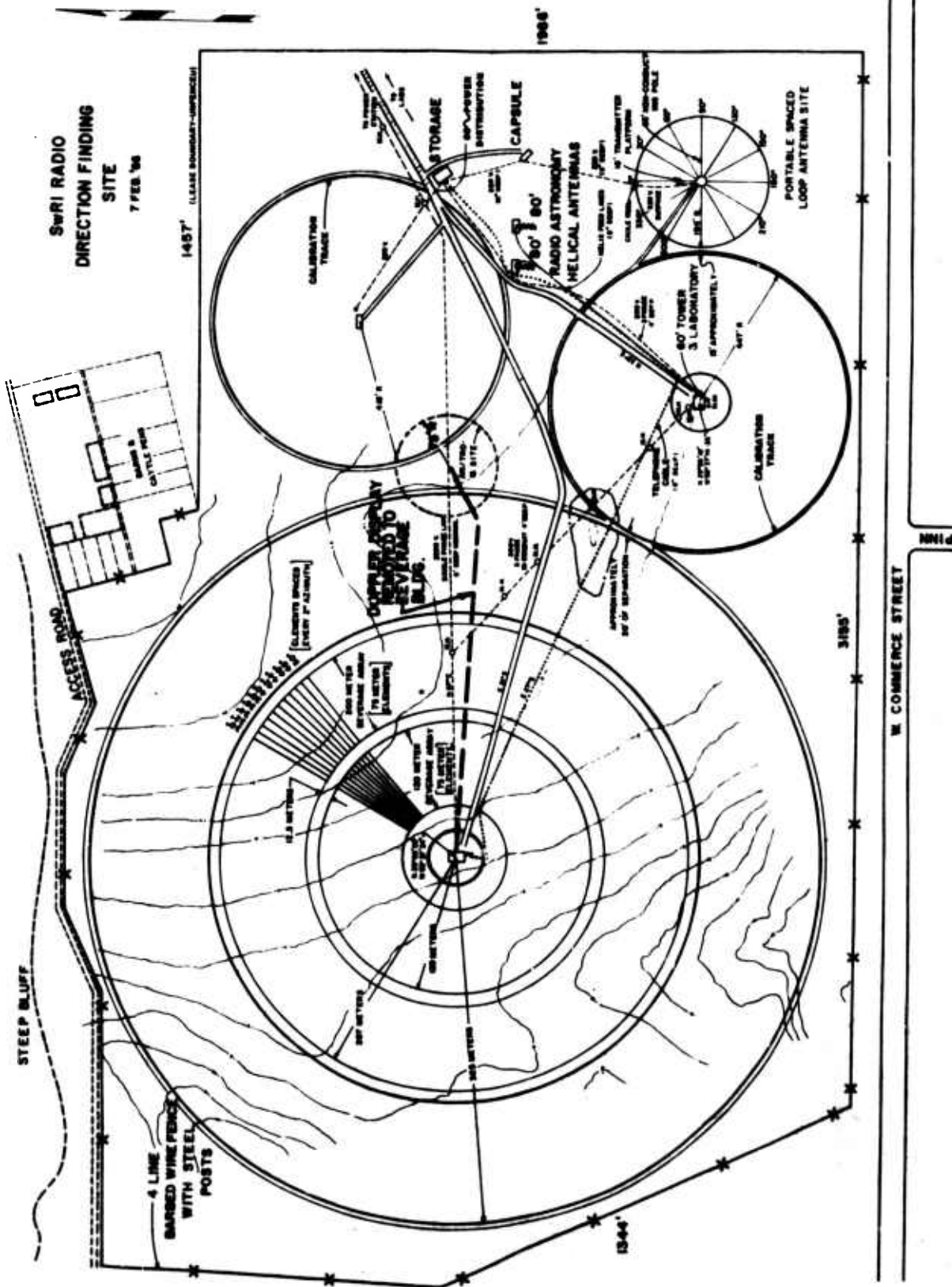

FIGURE 9. SITE LOCATIONS OF CONCENTRIC 75-METER ARRAYS



FIGURE 10. AN/TRD-15 DOPPLER ARRAY INSTALLATION

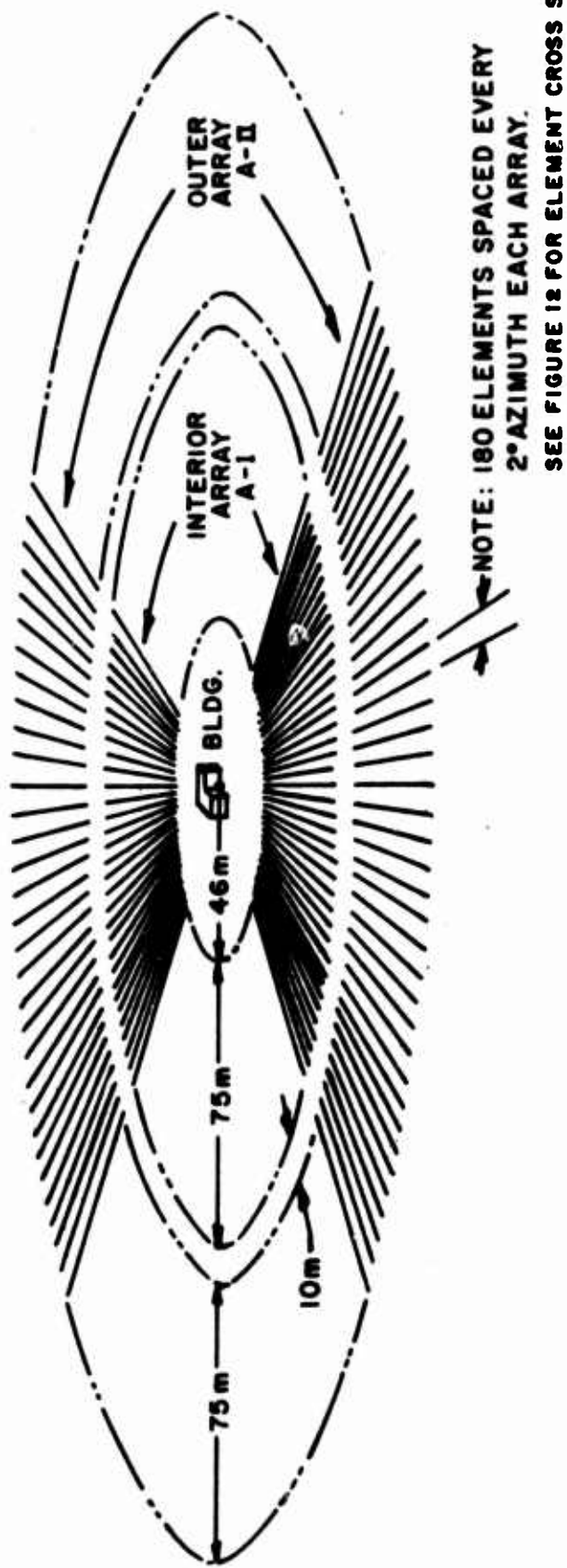

FIGURE 11. PARTIAL PLAN OF CONCENTRIC ARRAYS

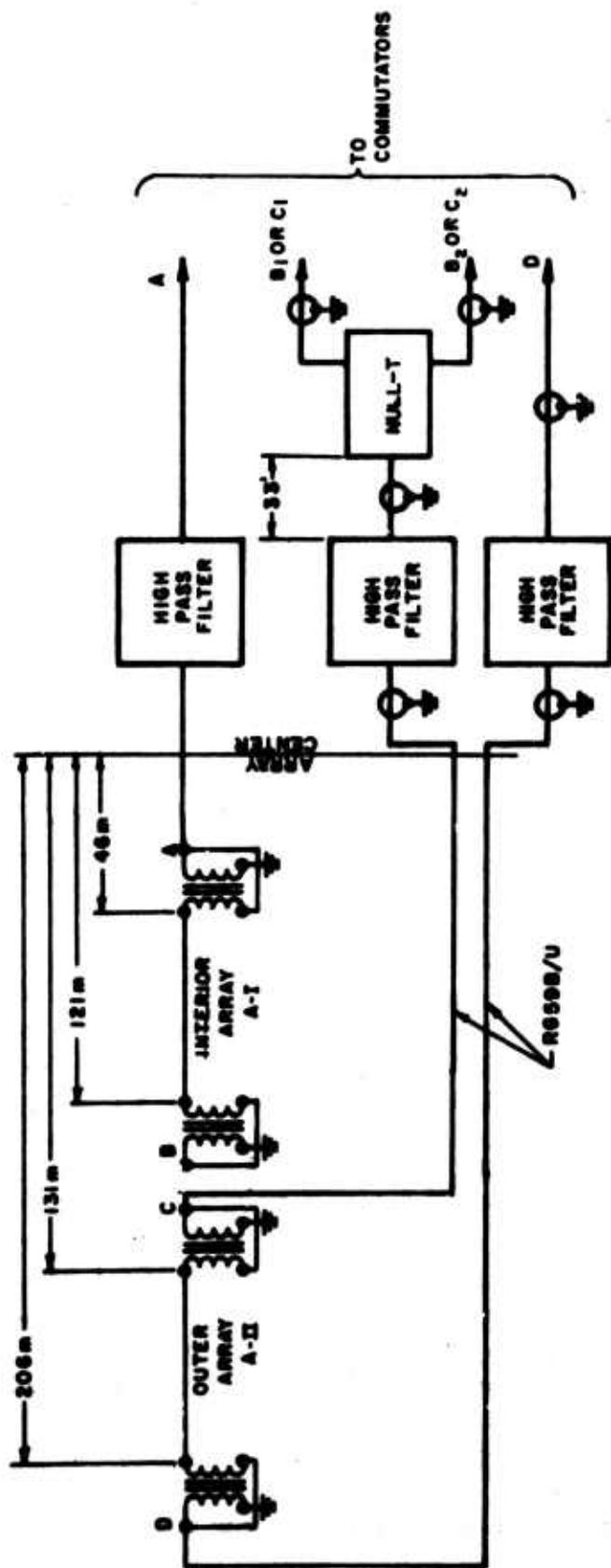

FIGURE 12. CROSS SECTION OF ONE ANTENNA RADIAL.

- (2) Maintain a constant output impedance and element isolation (greater than 20 dB) regardless of the number of antennas summed or the signal frequency.
- (3) Transient free switching in the signal path.
- (4) Each antenna gate to be matched in gain and phase as a function of frequency.
- (5) Commutate a circular array of 180 elements having an element located every 2° azimuth.

Three digital commutator models (Mark I, Mark II, and Mark III) were constructed and used during the testing of various Beverage antenna arrays. The first 180 input solid state digital commutator (Mark I) was designed and constructed under Contract No. NObsr-85364 and tested under a present contract. Operational theory, design and performance are described in Reference 2. The Mark II commutator was constructed under Contract DA 36-039-AMC-02346(E) while the Mark III commutator was constructed under the present contract.

The basic principles of operation and primary control circuit logic are identical in all models.* The primary differences lie in RF gate design and circuit layout construction.

The RF gate for the Mark I commutator utilized a series shunt arrangement of diodes to control the signal flow from the individual antennas to the receiver. A positive voltage applied to the gate effectively isolates the antenna from the receiver, while a negative voltage provides a low impedance path between the antenna and receiver. Although very good performance was obtained (see Reference 2) objectionable features of the diode RF gate were (1) a pedestal type gate wherein the RF signal was superimposed upon a DC pedestal when the gate was open, (2) relatively severe switching transients at the receiver input, due to switching the gate ON or OFF by a pulse from the control circuit logic, so that the receiver sensitivity was limited by commutation noise below about 7 MHz, and (3) loss of summing capability due to a varying summing junction impedance whenever more than 8 diode gates, common to one receiver input, were switched on at the same time.

*Differences also exist in control circuit logic between the various models but provide flexibility for signal processing and do not affect the basic purpose of the commutator.

The major design improvement in the Mark II and Mark III digital commutators was in the RF switch performance. In order to overcome the above disadvantages, a balanced push-pull transistor amplifier gate was developed (with transformer coupling on input and output) to produce a transient free pedestal less gating circuit.

A buffer amplifier stage between each transistor gate and the point of summation was also added to provide a constant output impedance from the commutator. Consequently, the predicted increase in array gain as the number of antennas elements is increased was fully realized (see Figure 27, Section E).

Design, construction, and operational details of the Mark II commutator are discussed in Reference 5 and Appendix I of this report. The Mark III design is described briefly below and in more detail in References 7 and 9.

NOTE: Because of the relatively low dynamic range of the push-pull transistor amplifier (30-mv maximum for linear operation) considerable interference was experienced from local transmitters operating in the broadcast band (field strength of one has been measured in excess of 300,000 microvolts per meter). These broadcast signals coupled with the antenna factor saturated the amplifier. It was necessary therefore to design and install a high-pass filter in each antenna circuit between the antenna and RF input to the commutator. Filter circuit design and response are given in Appendix I.

The Mark III digital commutator has 360 stages (versus 180 for the Mark I and Mark II versions) and an improved layout. Each stage in the commutator contains one RF gate and its associated flip-flop in the shift register ring counter. All components for one stage are mounted on a printed circuit board as shown in Figure 13. Thirty stages (cards) on one chassis comprise one commutator module as shown in Figures 14 and 15. The required logic connections are brought out to plugs on the rear of each chassis which may be jumpered on the same chassis to form a 30-stage ring commutator or to other units to form a larger ring commutator in multiples of the 30-stage units. Combinations of commutator units may be made to permit commutation of inputs up to 360 (12 commutator units). However, in all performance tests conducted to date, the commutators were operated in 180-stage groups.

RING COUNTER STAGE

RF GATE

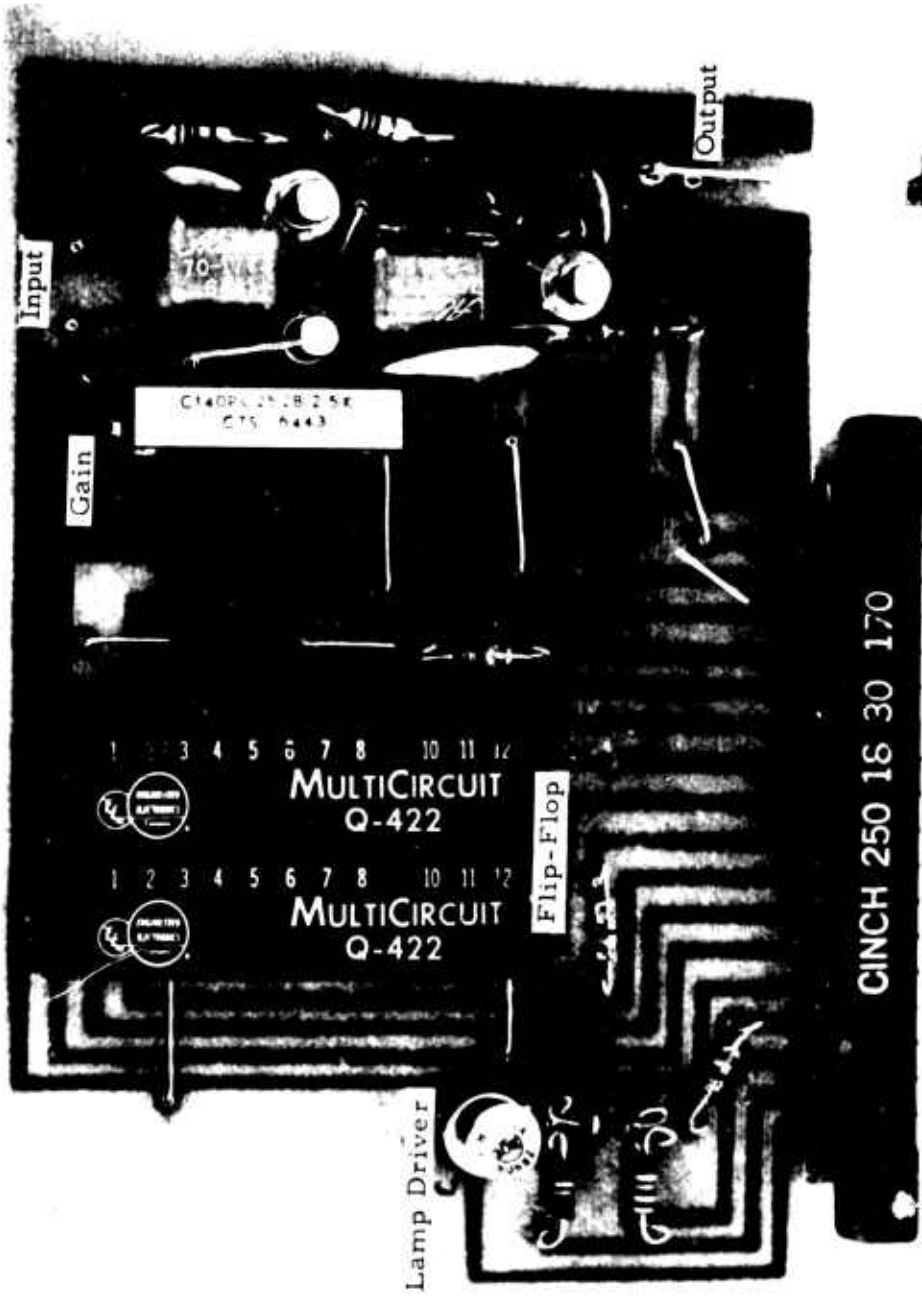

FIGURE 13. CIRCUITS FOR ONE COMMUTATOR STAGE



C-24059

FIGURE 14. 30-STAGE MODULE OF MARK III COMMUTATOR - FRONT VIEW

C-24060

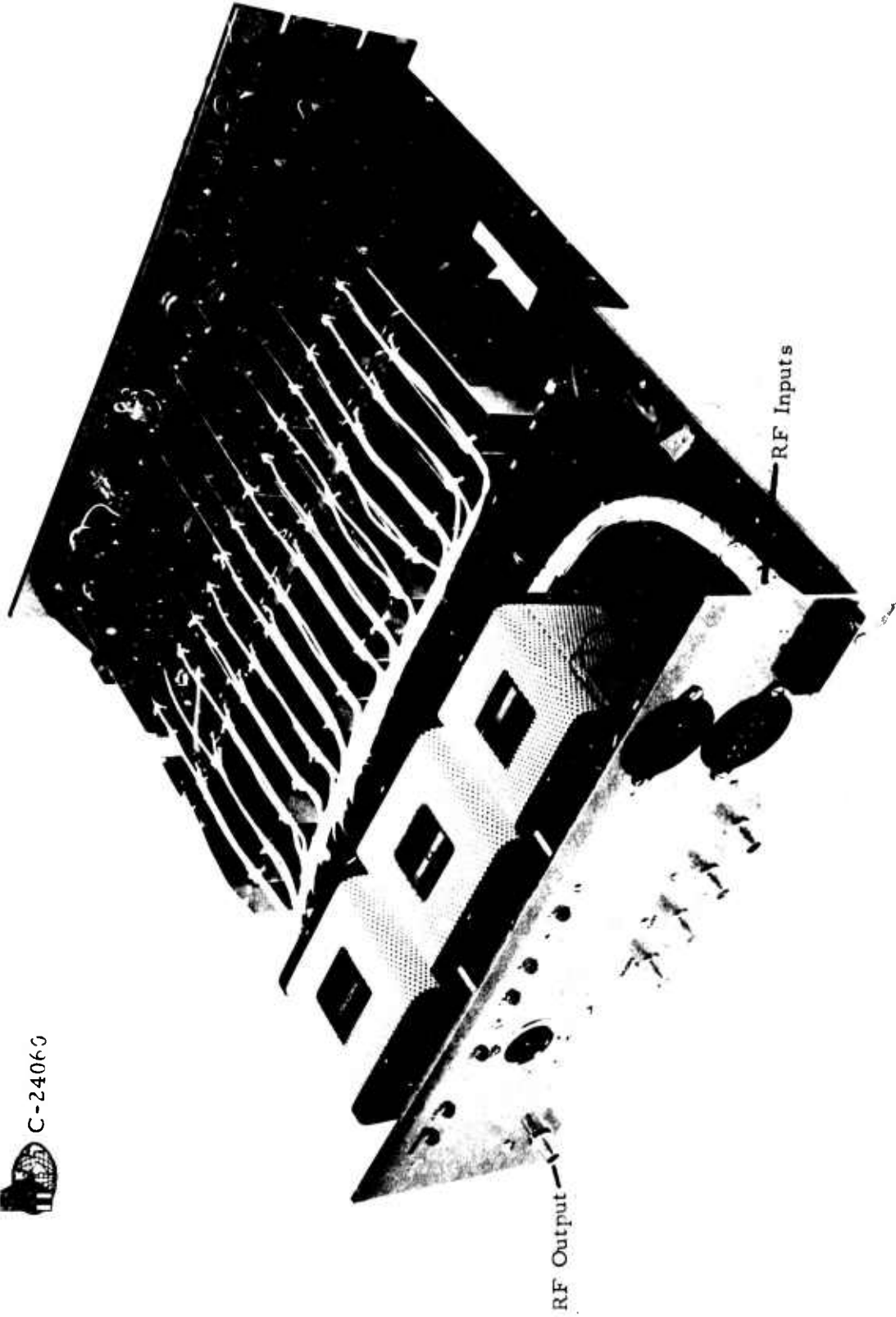

FIGURE 15. 30-STAGE MODULE OF MARK III COMMUTATOR - REAR VIEW

Each commutator module contains its complement of power supplies and a self-contained pulse generator for test purposes. The frequency of the pulse generator is variable to enable a linear presentation of the scan, up to 15 scans per second when the 30-stage unit is operated independently of the master control circuits.

The master control unit contains the necessary optical generators and logic functions to provide the triggering of clock pulses to the ring counter RF-gate stages, the circular sweep voltages for a CRT indicator, the synchronization signals and automatic bearing readout functions. The optical generator chassis is shown in Figure 16 and the master logic control in Figures 17 and 18. A 180-stage commutator is shown in Figure 19; another view of the commutator is shown in Section D.2.

The purpose of the 360 stages in the Mark III design were threefold:

- (1) To provide greater flexibility so that any 360° circular array having 30 to 360 elements may be commutated (specifically 30, 45, 60, 90, 120, 180, and 360 elements).
- (2) To function as two 180-input sections operating in parallel to enable simultaneous and synchronous scanning of inner and outer feedpoints of a 180-element circular array.
- (3) Synchronous sampling of a 180-element array by two 180 stage commutators on the same antenna terminals to obtain a difference scan and null display. A simplified block diagram of the commutator system is shown in Figure 20; representative CRT displays are shown also.

The scan rate of all digital commutators is exactly ten scans per second.

2. Receivers and Indicators

The receivers and indicators for two existing DF sets (AN/FRD-10 and AN/TRD-4A) were modified and adapted for operation with the Beverage antenna arrays and digital commutation. Modifications to the AN/FRD-10 instrumentation are discussed in Reference 2, while the AN/TRD-4 circuits are described in Reference 5 and Appendix I of this report. A photograph of the instrument room is shown in Figure 21.

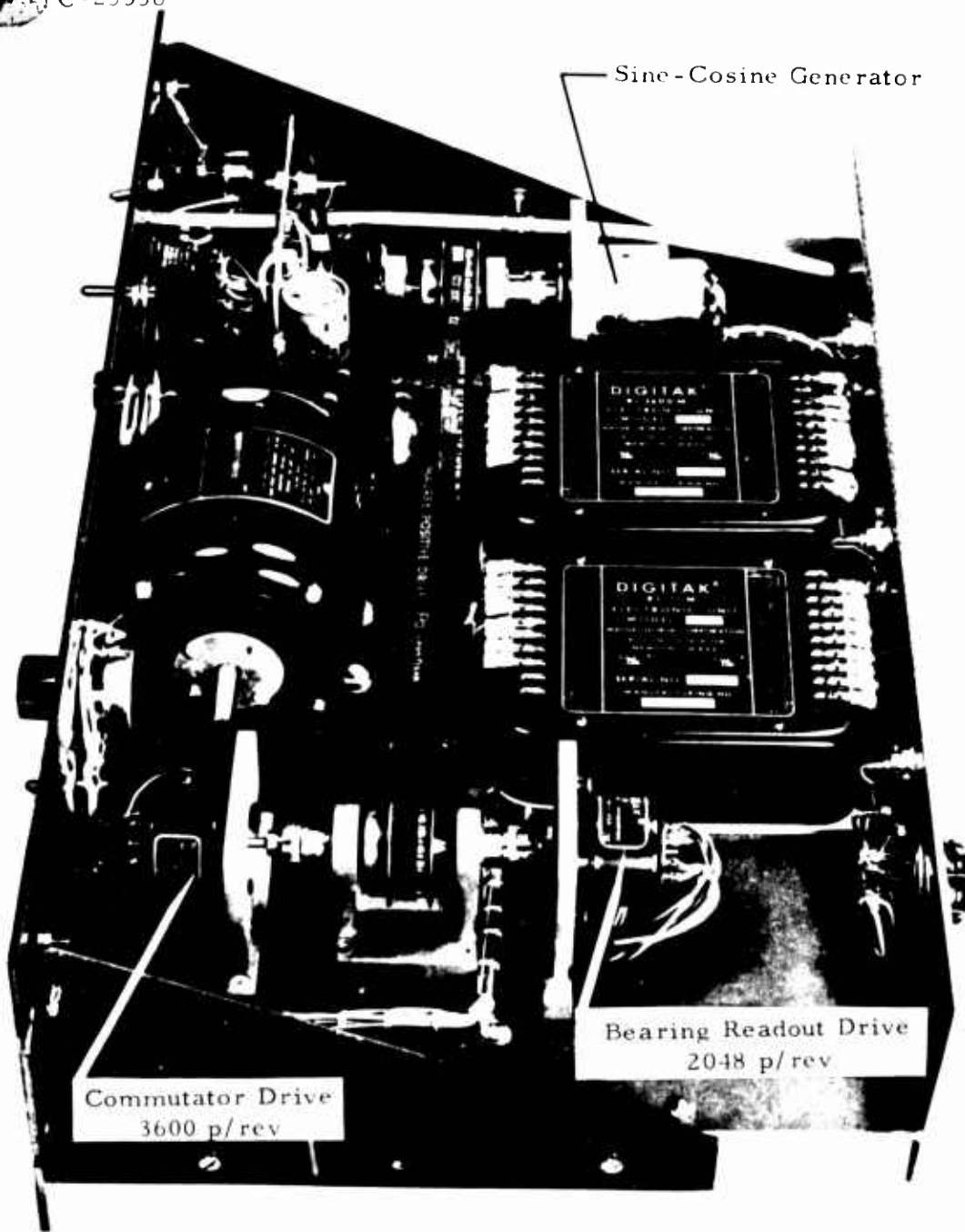
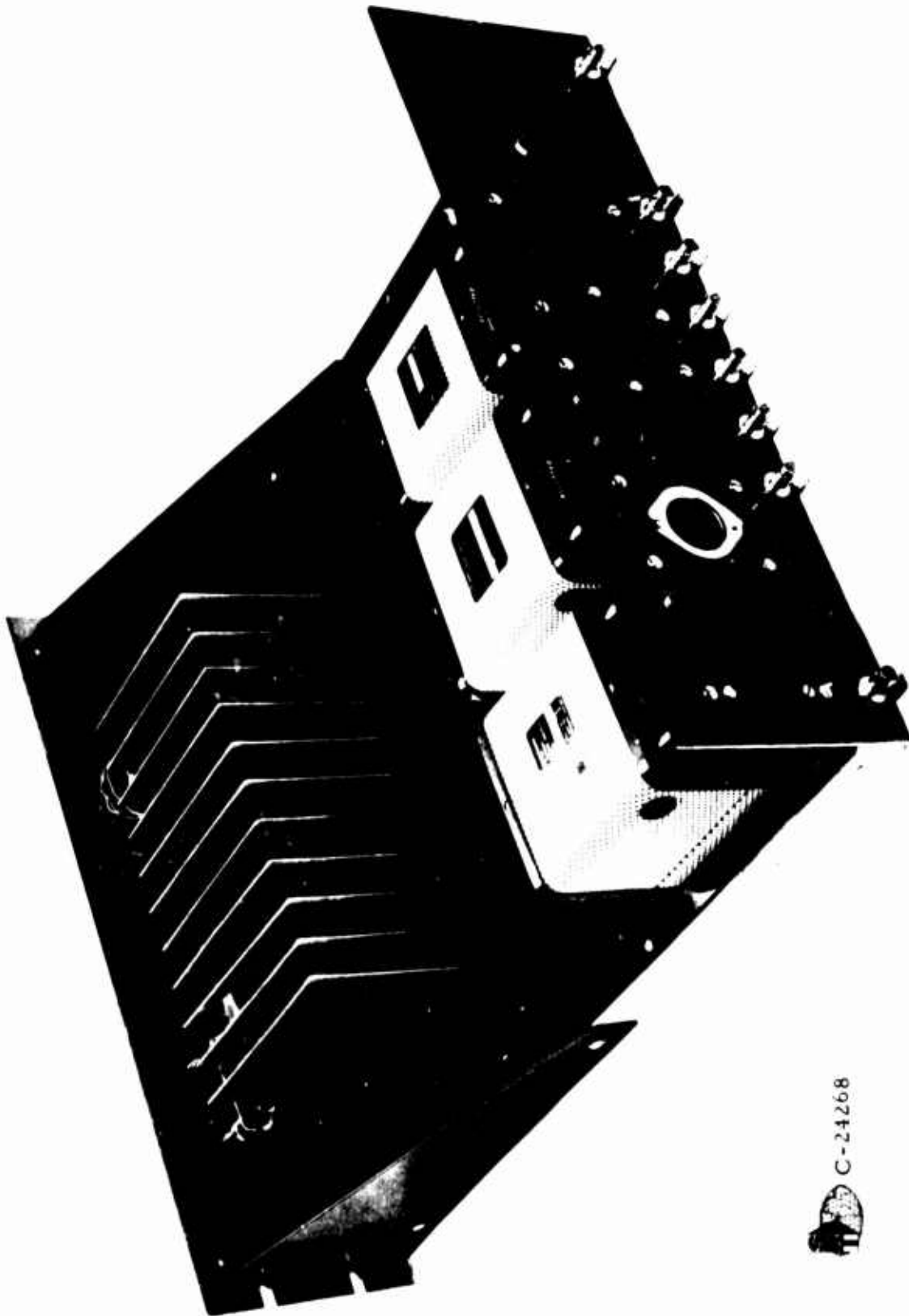

FIGURE 16. OPTICAL GENERATOR CHASSIS



 C-24267

FIGURE 17. MASTER CONTROL CHASSIS FOR MARK III
COMMUTATOR - FRONT VIEW



 C-24268

FIGURE 18. MASTER CONTROL CHASSIS FOR MARK III
COMMUTATOR - REAR VIEW

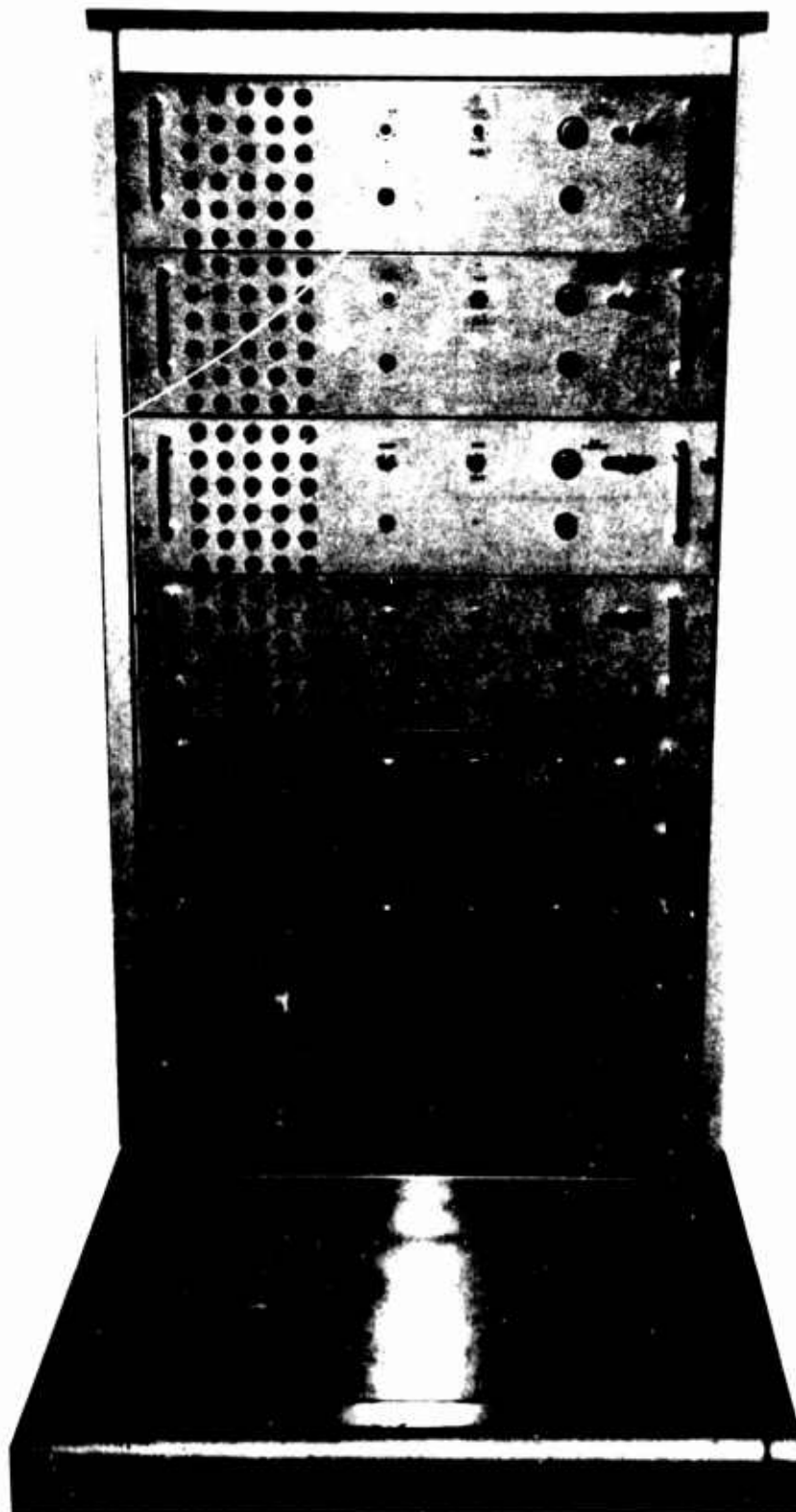
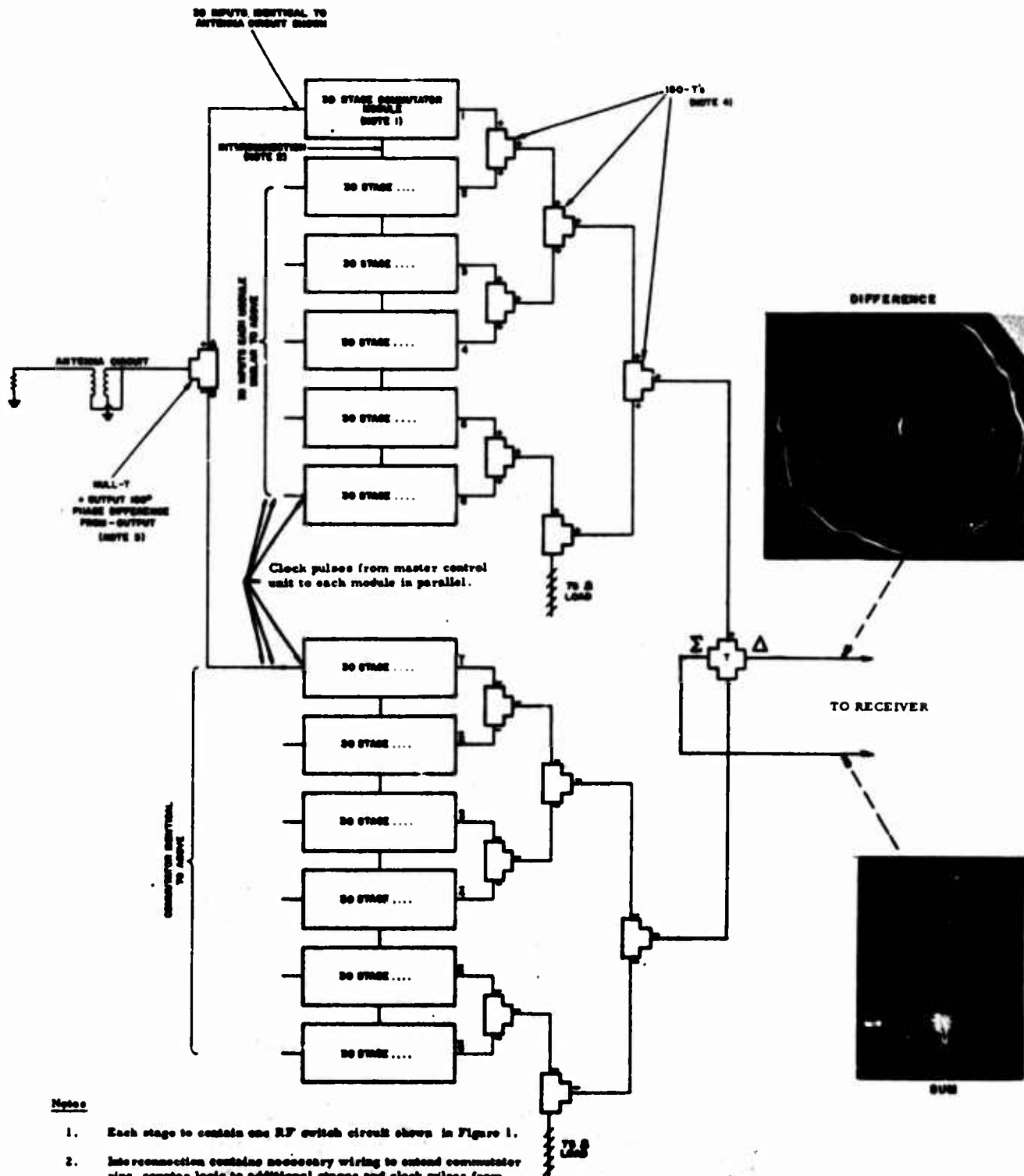

FIGURE 19. MODULES GROUPED FOR 180-STAGE
DIGITAL COMMUTATOR



Notes

1. Each stage to contain one RF switch circuit shown in Figure 1.
2. Interconnection contains necessary wiring to extend commutator ring counter logic to additional stages and clock pulses from master control channel.
3. Adams-Russell power divider. See Figures 5 and 7.
4. Adams-Russell power divider connected in reciprocal mode (similar to Wall-T except inputs add in-phase).

FIGURE 20. SIMPLIFIED DIAGRAM OF DUAL COMMUTATION SYSTEM

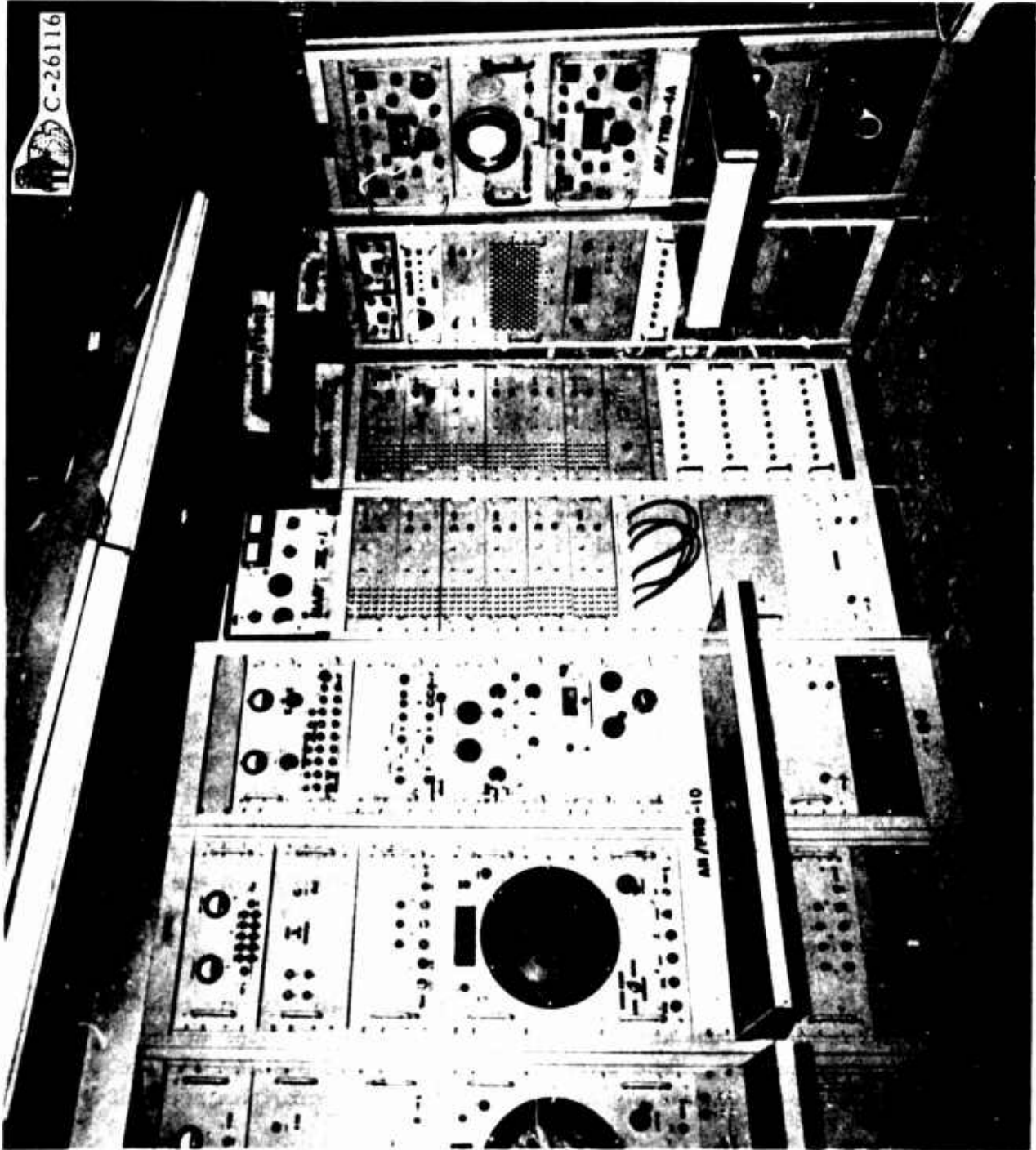

FIGURE 21. DF INSTRUMENTATION LAYOUT

3. The AN/TRD-15 Doppler

In order to observe the performance of the Beverage and AN/TRD-15 systems on side-by-side displays, the Doppler display was remoted to the Beverage instrumentation shelter. The Doppler pattern with 72-kHz subcarrier was picked off the indicator goniometer driving the IP 137 display. Cable drive circuits, shown in Figure 22 (blanking voltage was also transferred), would not drive a second IP 137 display; consequently, a general purpose oscilloscope with X and Y inputs was used with good results.*

E. Sensitivity Measurements

The vertically polarized field strength required to produce a 10-dB signal plus noise-to-noise ratio at the input to a DF receiver was measured for single Beverage antennas of several lengths and heights above ground. Measurements were also conducted on several array configurations of 75-meter antennas.

The instrumentation setup is shown in Figure 23. The technique employed was as follows:

- (1) With a target transmitter located in the far field of the antenna array, a field strength of 100 microvolts per meter was established near the array center at the desired frequency (constant carrier only).
- (2) Using the Beverage element lying in the plane of incidence, the receiver was tuned to the target signal.
- (3) The target transmitter was turned off, and the background noise level of the antenna was noted on the RMS voltmeter connected to the received IF output. Care was taken to be sure that no other on-the-air signal was located within the 2-kc pass band of the receiver. The antenna was decoupled from the receiver by at least 100 dB, and the receiver noise was also measured and recorded.

*The remote CRT display had no provisions for azimuth bearing readout. Bearings were read on-site and at the instrumentation shelter at the AN/TRD-15 array center. The purpose of the remote display was to enable side-by-side comparisons and to facilitate 16-mm film recordings.

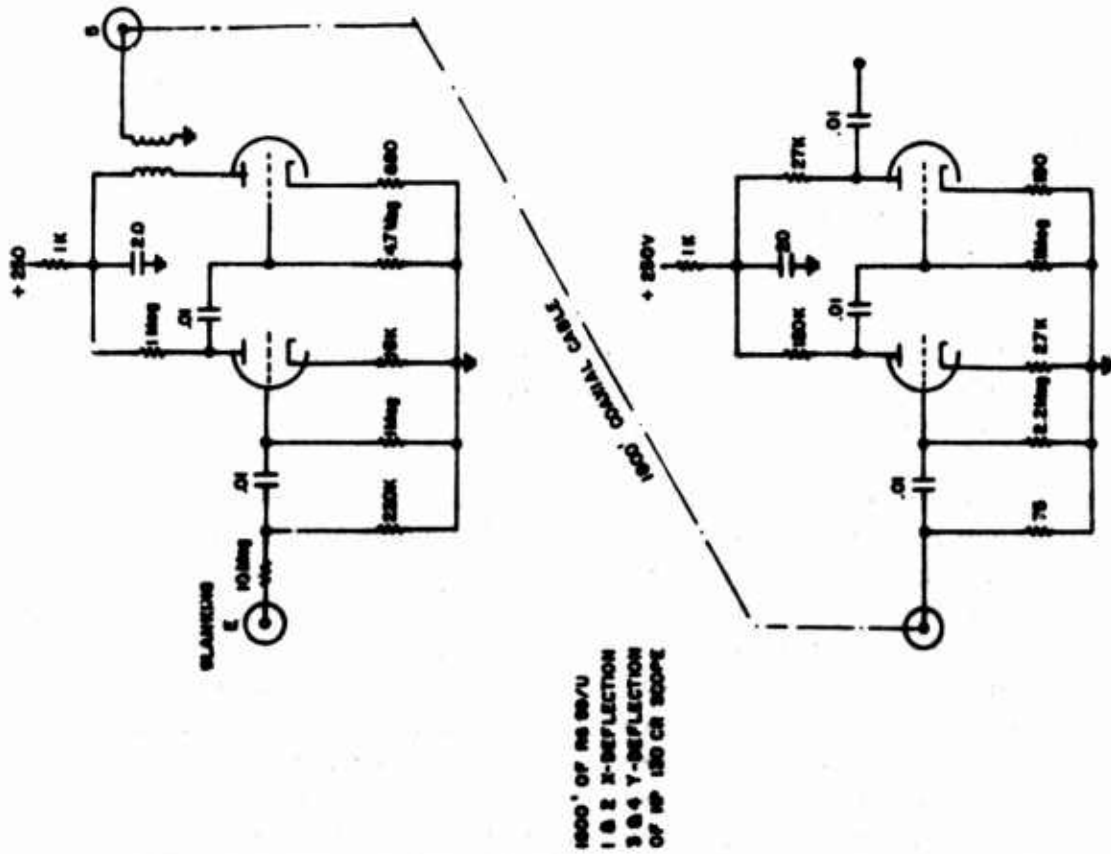

B. BLANKING AMPLIFIERS

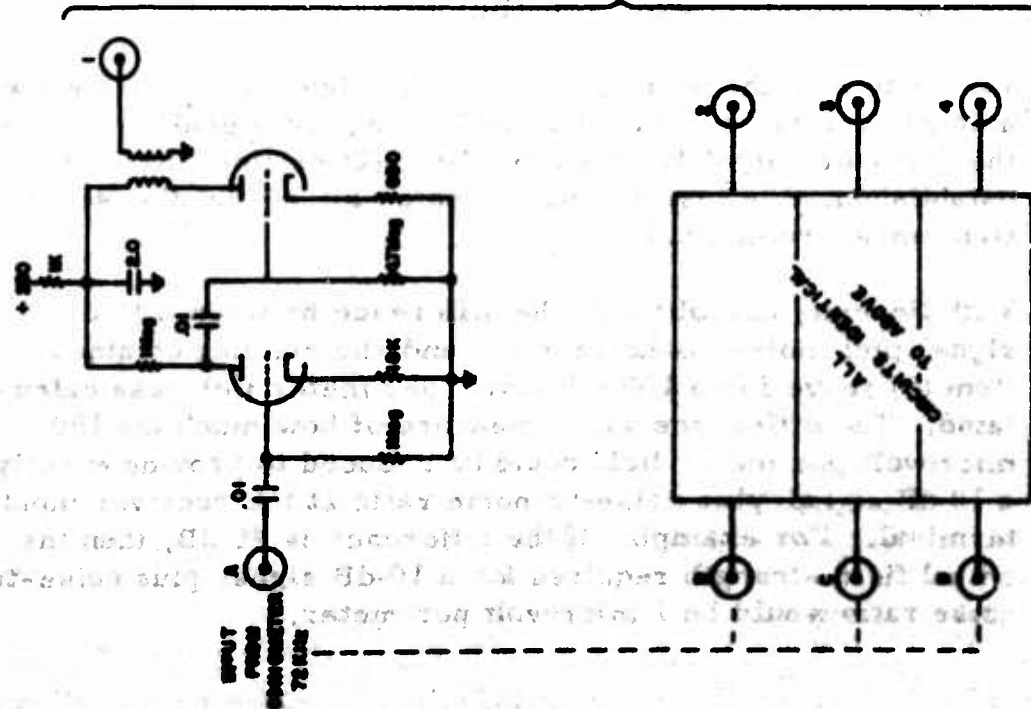

A. LINE DRIVER AMPLIFIERS FOR DISPLAY SIGNAL

FIGURE 22. AMPLIFIERS FOR REMOTE DISPLAY OF DOPPLER PATTERN

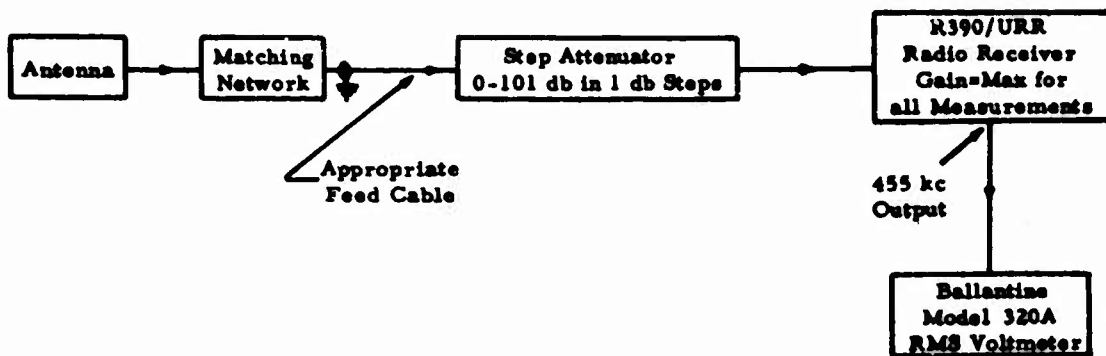

FIGURE 23. INSTRUMENTATION FOR SENSITIVITY MEASUREMENT

- (4) The receiver linear dynamic range without AGC was measured using a signal generator (always greater than 30 dB for the receiver used).
- (5) The transmitter was turned on, and the received signal in volts was measured on the RMS meter. In order to stay within the dynamic range of the receiver, the input attenuator was adjusted so that the meter reading did not increase more than 10 dB over the largest noise reading of Item (3) above (the antenna noise was greater than the receiver noise for frequencies less than 10 mc/s) so that the reading was within the linear portion of the receiver. The signal plus noise reading was recorded in dB above the noise level of Item (3) by adding the known attenuation set into the input attenuator and the increase in meter reading in dB.
- (6) Linearity was checked by changing the signal strength a known amount such as 3 dB or 10 dB and noting the signal level at the receiver output followed exactly. (Once linearity was established, this test was not repeated for succeeding sensitivity measurements.)
- (7) With linearity established, the difference between a 10-dB signal plus noise-to-noise ratio and the reading obtained in Item (5) above for a 100 microvolt per meter field was calculated. The difference was a measure of how much the 100 microvolt per meter field could be reduced to provide exactly a 10-dB signal plus noise-to-noise ratio at the receiver input terminal. For example, if the difference is 40 dB, then the actual field strength required for a 10-dB signal plus noise-to-noise ratio would be 1 microvolt per meter.

1. Single Element Sensitivity Measurement

Signal-to-noise sensitivity measurements including front-to-back ratio measurements were made on single Beverage elements as a function of length, height, and frequency. Data were taken for element lengths of 27, 50, and 75 meters; element heights of 1.0, 0.5, 0.1, and 0.0 meter; and frequencies between 2 and 10 mc (a few data points above 10 mc in some instances). For each data point, comparative data were also obtained for a 29-ft monopole similar to an element used with the AN/TRD-4 direction finder (without top hat). Curves showing the field strength required to produce a 10-dB signal plus noise-to-noise ratio at the receiver terminals including the reference monopole are shown in Figure 24.

Of particular interest is the variation in apparent sensitivity of the monopole which is due to variations in the background noise from day to day. It is not unusual for the noise level to vary on an omnidirectional element, and it can be expected to vary with frequency, time, and azimuth; however, noise level variations should be less pronounced on the directional Beverage element with noise peaks (or increase in field strength for a given signal to noise ratio) occurring when the noise source is in the direction the element is pointing. Examples of the existence of directional noise can be seen at 4 mc/s on the 1-meter height data and 8 mc/s for the 1/2-meter height.

2. Array Sensitivity

Comparative sensitivity measurements were made between arrays A-I and A-II as a function of frequency and active elements used in the beam forming process of the digital commutator.

Data were obtained by the same technique described for single elements except that the digital commutator was included as part of the antenna circuit (as in single element measurements, the signal-to-noise ratio was measured at the DF receiver input terminals). Data for arrays A-I and A-II at 1.0-meter height and 3, 9, and 15 consecutive antennas forming the beam are plotted vs frequency in Figure 25. Data for 23 antennas only for array A-I at 1.0-meter height and array A-II at a new height of 0.1 meter are shown in Figure 26.

Although some improvement in signal-to-noise ratio was obtained below 5 MHz for the lower height array, the direction finding performance of the low profile array was superior to array A-I (elements at 1-meter height) and particularly for downcoming signals from close-in targets.

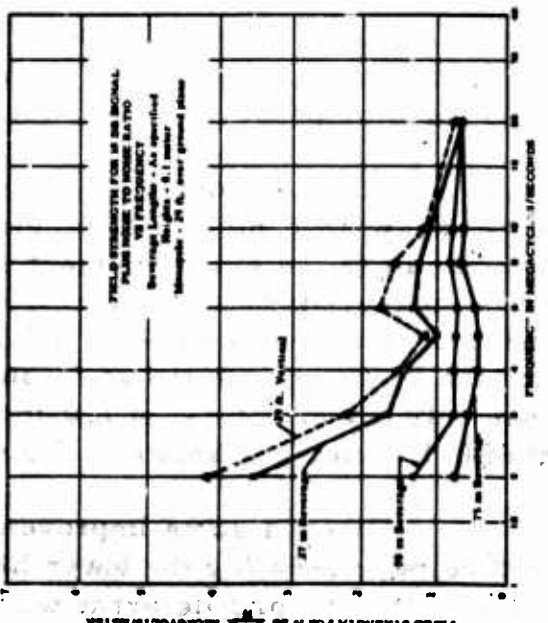
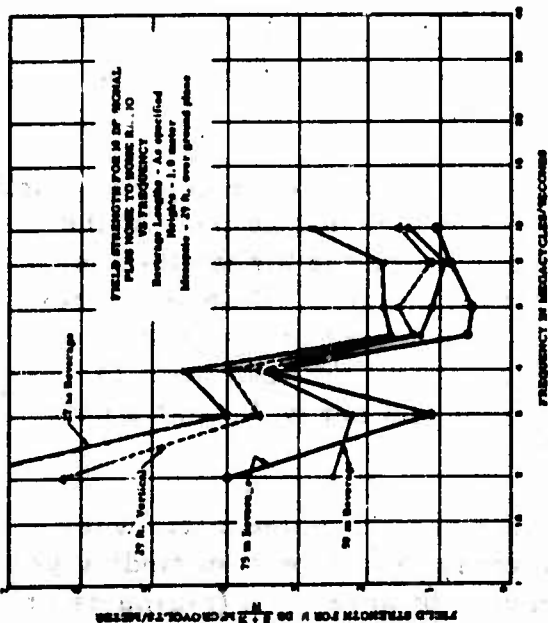
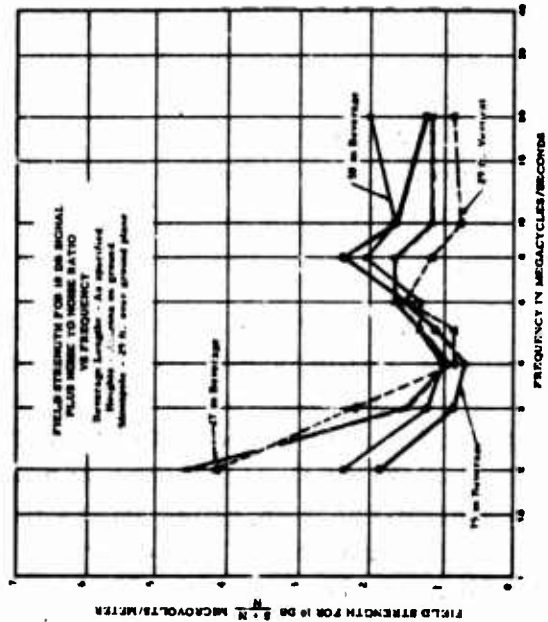
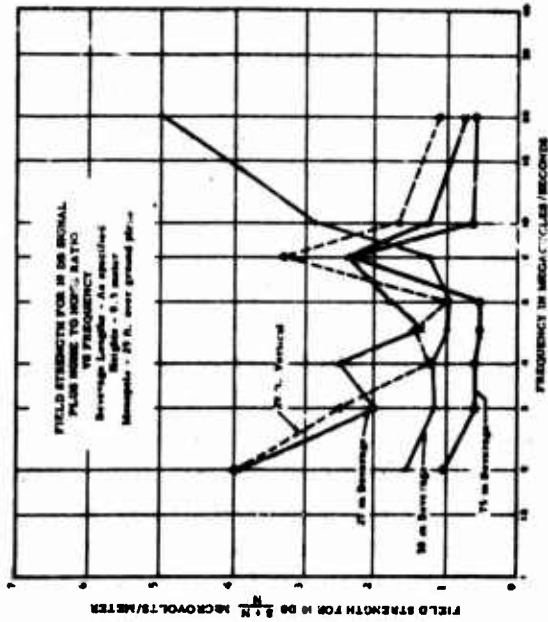

FIGURE 24. SINGLE ELEMENT SENSITIVITY

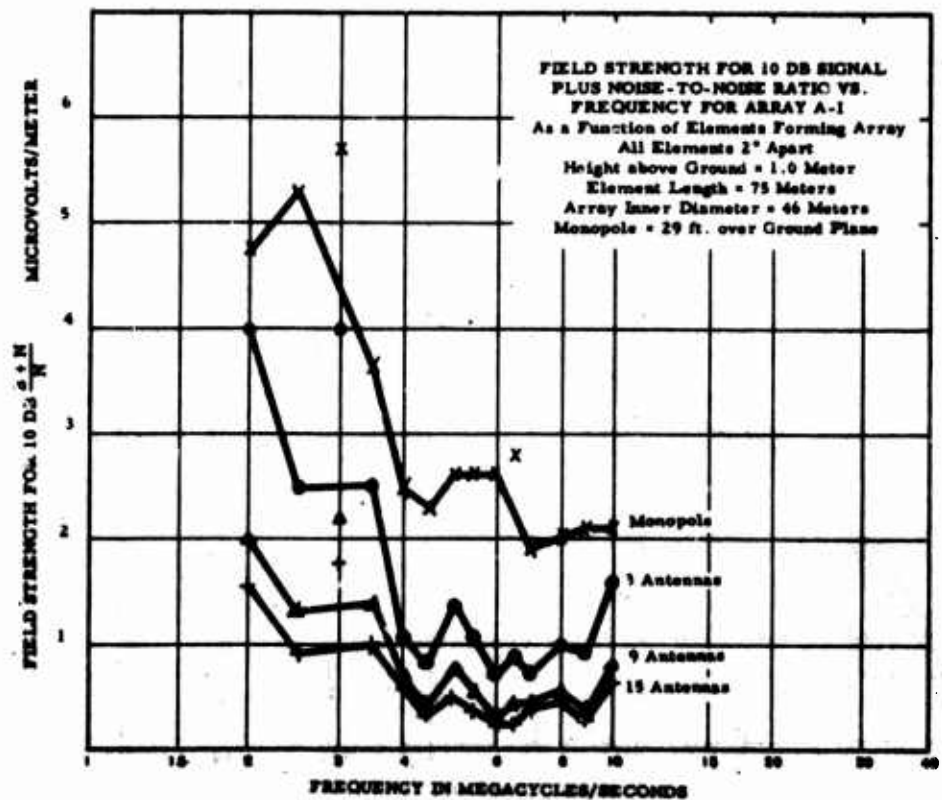
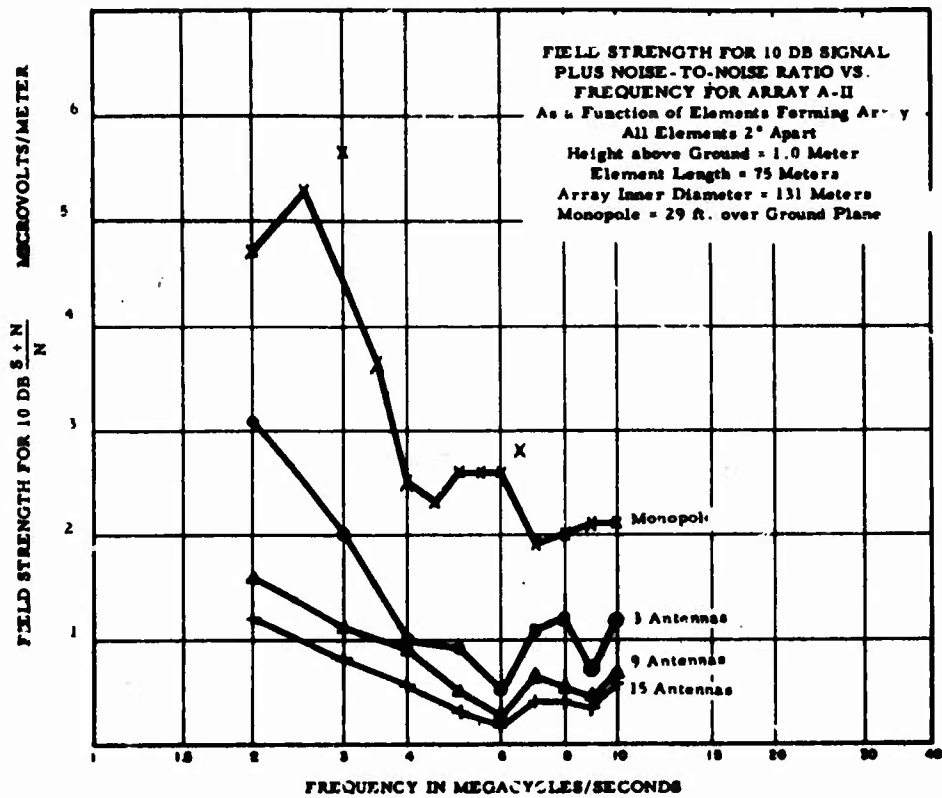

FIGURE 25. ARRAY SENSITIVITY

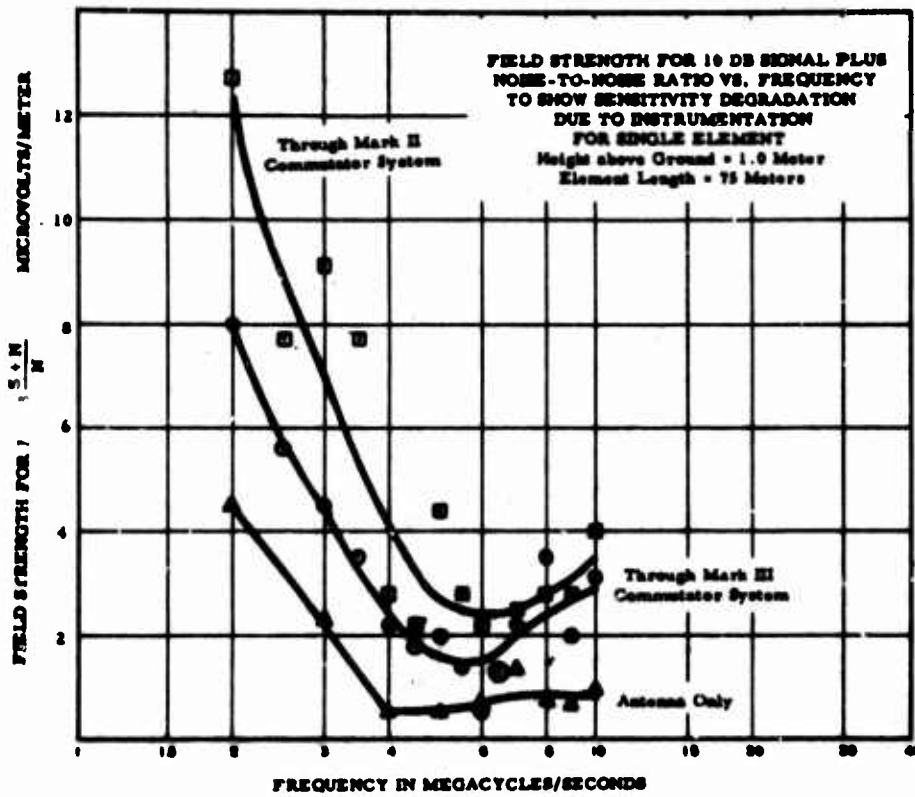

FIGURE 26. SENSITIVITY DEGRADATION DUE TO COMMUTATOR

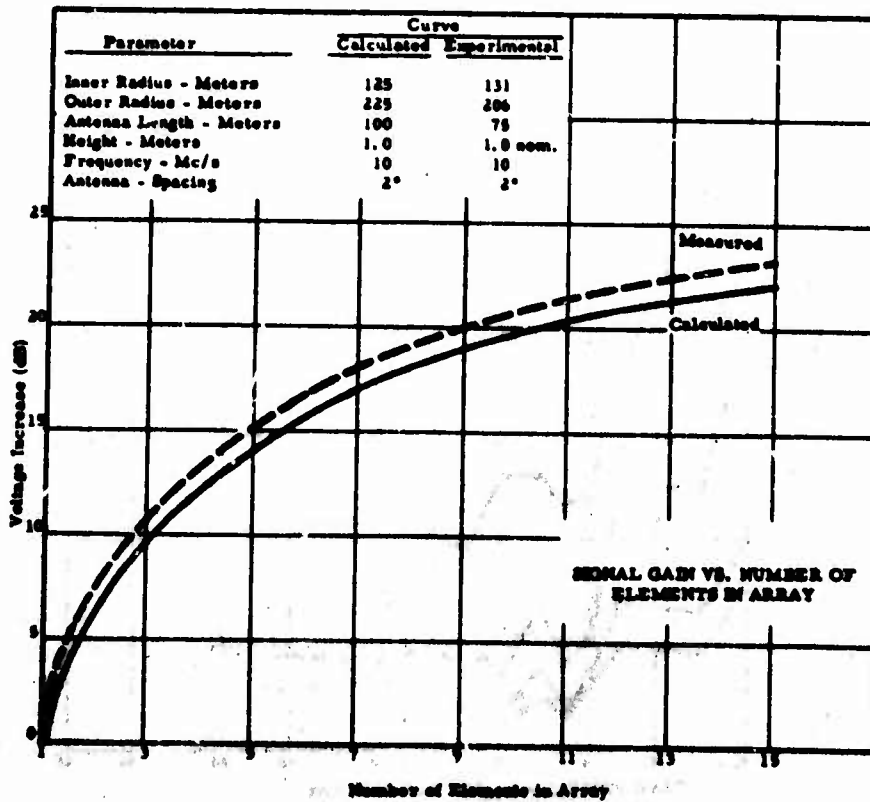

FIGURE 27. SIGNAL GAIN VS NUMBER OF ELEMENTS IN ARRAY

The effects of commutation are shown in Figure 27. Although the individual stages in the commutator exhibit about 12-dB gain, the overall effect of the commutator and summing junction is to degrade the signal-to-noise ratio as shown in the figure. However, it can be seen in Figure 25 that the single-element sensitivity is recovered when three consecutive antennas are summed.

The reason for signal-to-noise degradation is inherent in the commutator design. This is because the buffer amplifier between each RF gate and the summing junction remains at maximum gain regardless of the ON-OFF state of the RF gate. Consequently, the buffer noise of all 180 stages is added at the summing junction and, insofar as the DF receiver is concerned, appears as antenna noise. Such effects are not important in the overall system performance when the optimum number of antennas for minimum beamwidth (see Section III, F. 5) are commutated because the antenna noise again predominates when more than three antennas are summed.

3. Array Gain

The gain realized at 10 MHz by summation of consecutive antennas via the commutator is shown in Figure 27 for array A-II at a 1.0-meter height. Very good agreement is seen between the experimental measurements and theoretical calculations on an assumed array size very nearly the same as that tested. The results show that the summing capability of the Mark III commutator meets the design objectives.

F. Antenna Patterns

1. Theoretical Antenna Patterns

Pattern studies have been performed to investigate the suitability of the patterns for direction finding as a function of various antenna design parameters. This has been done theoretically [2, 4, 5, 7] by calculating the beamwidth, side lobe level, elevation plane response, polarization error, and various other characteristics as a function of frequency, polarization of signal, antenna length, height above ground, array diameter, element spacing, phased and nonphased inputs, methods of commutation, and certain other parameters. A number of the theoretical patterns have been checked experimentally with very good results as shown in Figure 28. Consistent agreement indicates that the mathematical model of the Beverage antenna can be accepted with confidence for both azimuth and elevation patterns.

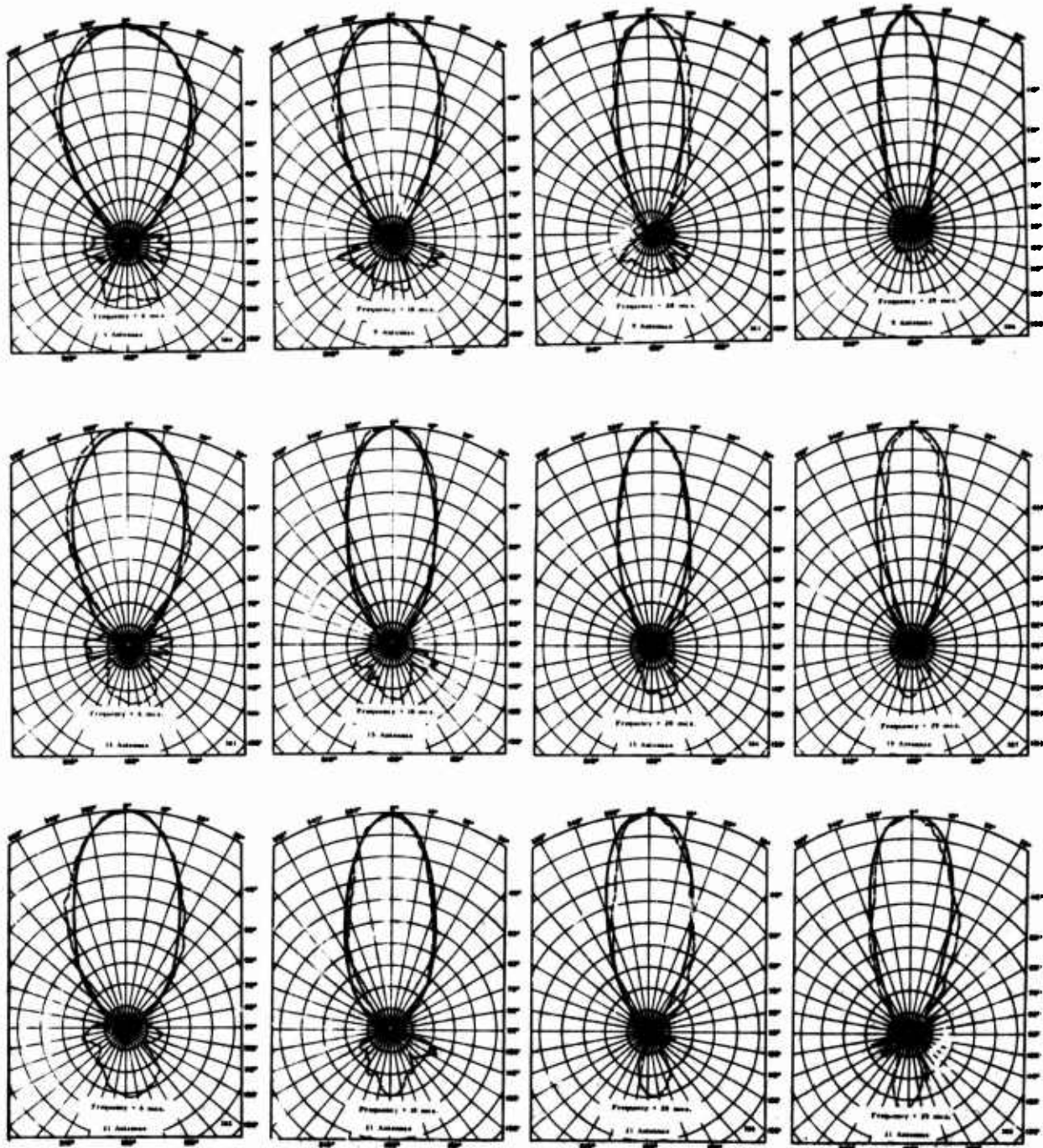

FIGURE 28. THEORETICAL AND EXPERIMENTAL ARRAY PATTERNS

2. Experimental Patterns

Experimental array patterns using target and on-the-air signals have been previously reported in detail for the 112, 300, and 27-mile arrays [2, 5]. Typical patterns for the 75-meter arrays are presented within Appendix I, pp. I-74 through I-78.

3. Difference Patterns

Two 180-input commutators were connected to the Null-T outputs C_1 and C_2 of Figure 12 to permit difference scanning techniques to be conducted.

The tests were devoted to study of difference scanning whereby a difference pattern can be established by setting up one beam via a commutator at C_1 to the right of the boresight antenna and a second beam via a commutator at C_2 to the left. The outputs of commutators were differentially connected as shown in Figure 20 to produce a null along the boresight path for conditions of pattern symmetry in the region of the boresight elements. The CRT display is inverted (zero signal at the tube periphery), and a very narrow beam indicating the direction of arrival of the signal can be obtained. The technique is demonstrated in Figure 29. Other null patterns of on-the-air signals are shown in Figure 30.

Tests of the difference scan method have shown an advantage over the "sum mode, particularly at frequencies below 8 MHz and on signals that have high fade rates or exhibit extreme beam swing. When such signals are viewed on a CRT with the normal positive deflection systems, the possibility of obtaining a good bearing is dependent upon the DF operator's experience and ability to judge overall pattern symmetry [2]. In addition, the minimum bandwidths obtainable by direct summation of elements around 2 MHz (see Section F.4) are too broad (40° to 50°) for the best determination of the maximum of the beam, whereas the null beamwidth is generally about 5° . It has been observed that good nulls with the difference scan method form only for the conditions of pattern symmetry and in the direction of arrival of signal. Therefore, it is also much easier to judge symmetry of the null which will reduce the error factor due to DF operator judgment.

Some thought has been given to reasons why the null forms only for certain conditions and also apparently indicating a good bearing:

- (1) A null forms only when the components of the propagated wave are symmetrical in the region of the boresight elements.



Figure 29a
Max Pattern Using
15 Consecutive Antennas 2° Apart



Figure 29b
Double Exposure Showing Left and
Right Beams Before Difference is
Taken. Each Beam is Obtained by
15 Consecutive Antennas 2° Apart.
Left Beam from Commutator B and
Right Beam from Commutator A.

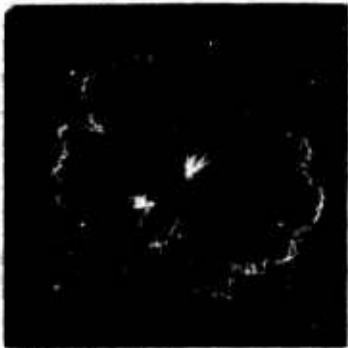

Figure 29c
Difference of the Beams of Figure 9b
Shown with a Null Type CRT Display.

Distance to Station -- 1402 Mi.

FIGURE 29. PATTERNS DESCRIBING MAX AND
NULL MODE OPERATION



Figure 30a
Null Pattern at 7.46 Mc/s
AF5TFZ, Lake Charles, La.
Distance = 329 mi.
Left and Right Beams -
15 Antennas each 2° Apart
Total Aperture = 62°



Figure 30b
Null Pattern at 8.59 Mc/s
KOK - Clearwater, Calif.
Distance = 1188 mi.
Left and Right Beams -
15 Antennas each 2° Apart
Total Aperture = 62°



Figure 30c
Null Pattern at 3.311 Mc/s
AF5BKH - Abilene, Texas
Distance = 220 mi.
Left and Right Beams -
15 Antennas each 2° Apart
Total Aperture = 62°

FIGURE 30. TYPICAL NULL PATTERNS

- (2) It has been theoretically predicted and experimentally observed that the presence of horizontal polarization causes the array pattern to appear unsymmetrical. This is because the phase of the horizontal component shifts 180° from one side of the boresight to the other while the phase of vertical does not. Consequently, the induced voltages add one side and subtract on the other. Therefore, a good null can form in the boresight direction only when the magnitude of the horizontal component is less than the vertical.
- (3) Although it may be that symmetry conditions for the horizontal component could occur at some azimuth other than the boresight, conditions would no longer be optimum to form a null because signals due to the vertical component, received from the right and left beams, are not of equal magnitude (the major part of the vertical component of the propagated wave apparently deviates very little from the boresight path).

For conditions of severe multipath interference, observations have indicated that good nulls seldom form except during instants of symmetry about the boresight element. It has been noted that the null that forms occurs at nearly the same azimuth regardless of the rate of fade or bearing swing noted on a max-type display.

4. Sampling at the Array Periphery

Brief tests were conducted to investigate the feasibility of sampling a circular array around its outer periphery (outside feeds) (see Figure 12 input to commutators B or D). Feed cables were gathered in groups of ten each and returned to the instrument shelter at the array center so that the effects of the feed cables on the antennas would be minimized (no adverse coupling effects were noted). Although few bearings were taken using outside feeds, the performance of the outside feed versus inside feeds (beamwidths were also compared, see Section F.5) on live signals was observed:

- (1) The array pattern appears to be more narrow when outside feeds are used, particularly in the 6 to 10-dB regions.
- (2) The rate of information could be doubled.
- (3) Effects of diversity operation were apparent.

- (4) The concept of commutation around the outer feeds required some discipline (see Figure 31) because a given element was not sampled simultaneously at each end. For a given direction, the elements diametrically opposite in the array were sampled at the same time, one at the inner feedpoint and the other at the outside feedpoint.

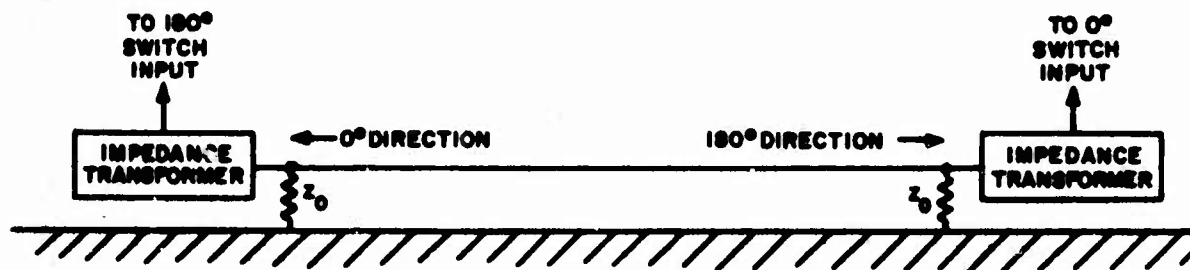

FIGURE 31. METHOD OF COMMUTATING A SINGLE ANTENNA FOR TWO DIRECTIONS 180° APART

- (5) No change in array performance or pattern shapes (particularly the back lobe) was noted when the terminating resistors at the outside feedpoints were replaced by an impedance matching transformer and feed cable.

5. Array Beamwidths

The 3-dB beamwidths of the CRT patterns were measured for several of the Beverage arrays by using the electronic cursor and digital bearing readout on the AN/FRD-10 indicator. Beamwidths for arrays A-I (inside feeds), A-II (inside feeds) and A-III (outside feeds) are shown in Figure 32. Array A-I height above ground was 0.25 meter while A-II was 0.1 meter. Beamwidths are plotted as a function of frequency and the number of consecutive antennas forming the beam. In all instances, antenna inputs were summed directly without external phasing.

Comparable data for the 112-meter array previously reported [2] are shown in Figure 33. Theoretical beamwidths as a function of feedpoint radius and frequency for 15 consecutive antennas forming the beam are shown in Figure 34. The optimum beamwidths obtainable by direct summation of 75-meter elements are shown in Figure 32D for the three-array configuration. Note the slight reduction in beamwidth obtained in array A-III for outside feeds (A-III₄) over inside feeds (A-III₂). By itself, beamwidth reduction would not justify the added cost of feed cables for outside feeds; however, the advantage of increased efficiency and diversity operation may be sufficient to justify its consideration.

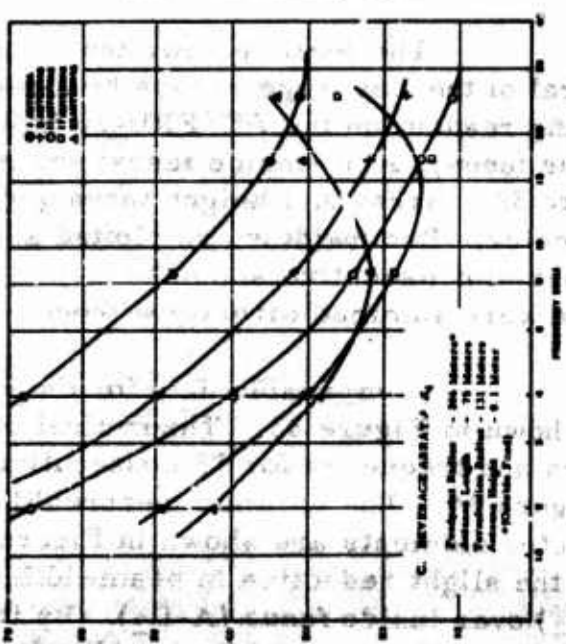
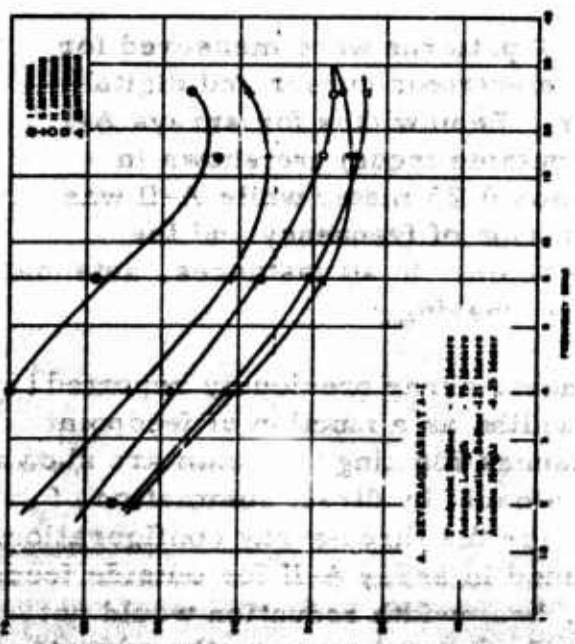
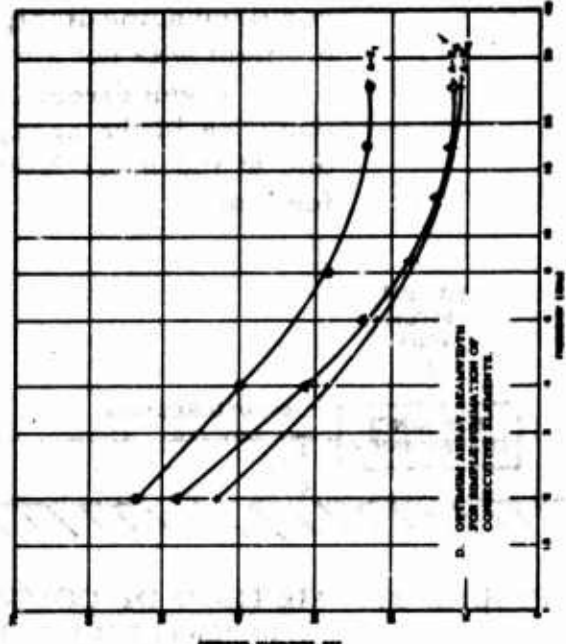
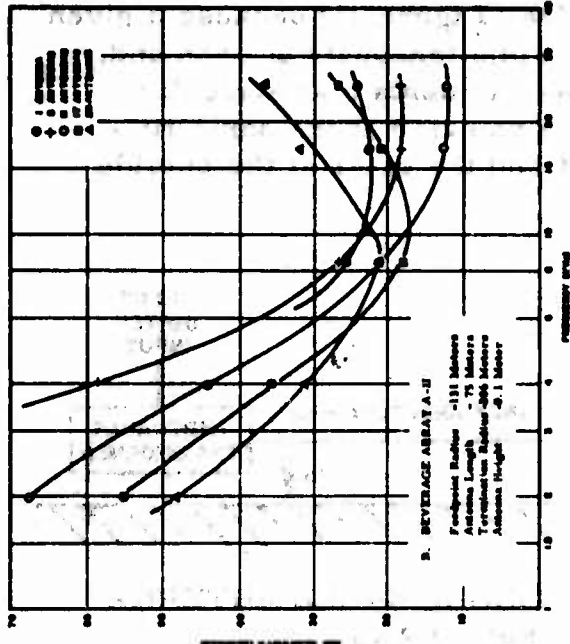

FIGURE 32. MEASURED BEAMWIDTHS VS FREQUENCY - 75-METER ARRAYS

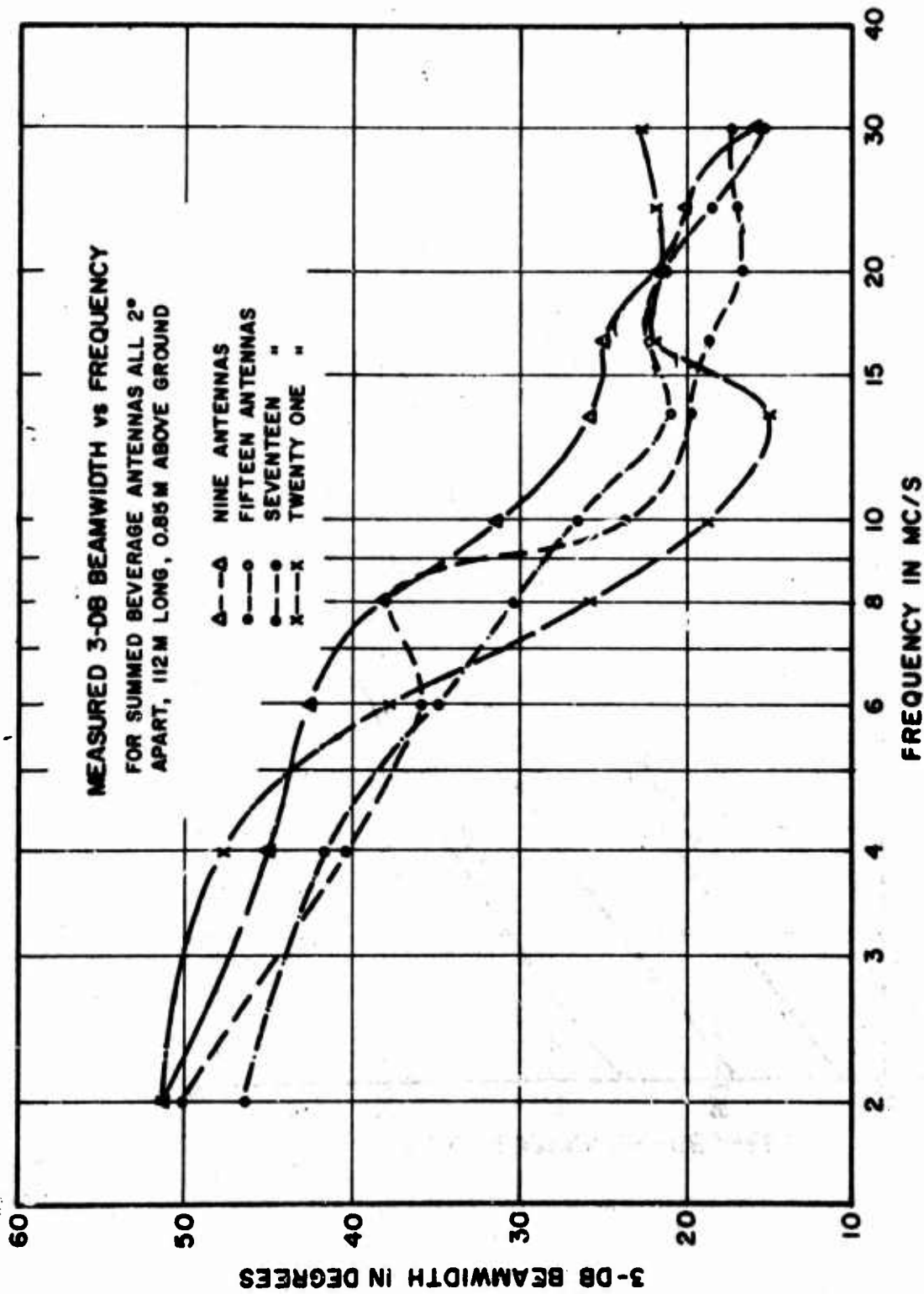

FIGURE 33. MEASURED BEAMWIDTH VS FREQUENCY -
 112-METER ARRAY

L = 100 meters

h = 1 meter

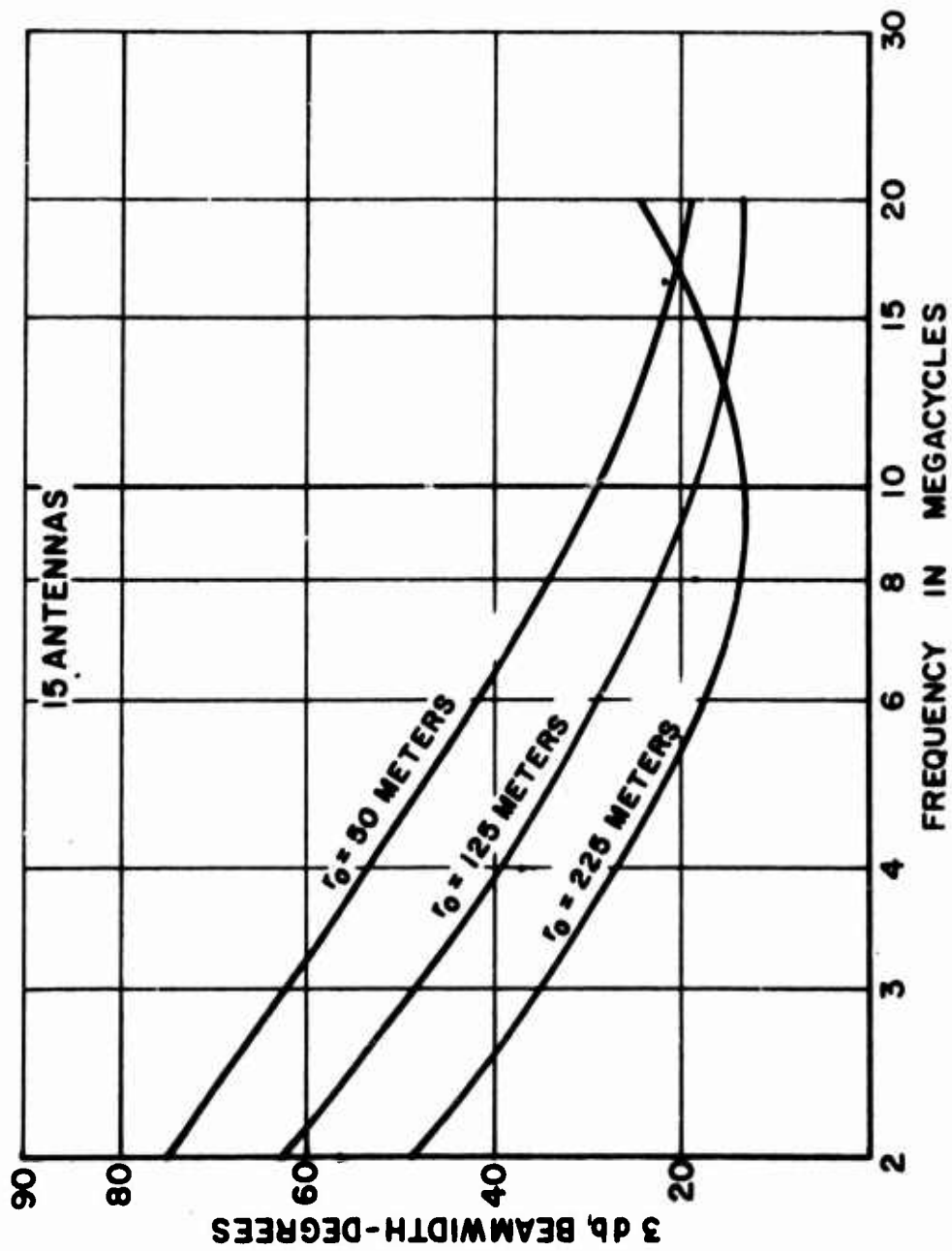

FIGURE 34. THEORETICAL BEAMWIDTHS VS FREQUENCY AND
ARRAY RADIUS - 15 ANTENNAS

6. Effect of Reducing Number of Array Elements

Experiments were conducted to determine if the number of elements in an array could be reduced to something less than 180 by removing every other element from the commutator input and programming the commutator for longer dwell time per antenna (for 180 elements and 10-cycle sweep, the dwell time was 555 microseconds, whereas, for 90 elements the time required is 1.11 milliseconds). It was immediately evident that a 4° spacing of elements would cause an undesirable amount of cogging on the CRT display at frequencies greater than 10 MHz. It is thought that the directivity of single elements is too narrow for such a large step for sequential commutation unless some other blending technique were employed.

7. Phased Arrays

Theoretical studies [2, 5, 7] have shown that extremely narrow beams such as those shown in Figure 35 can be obtained by phasing the antenna inputs to approximate a broadside array. Such a beam could be obtained by capacitive goniometers now in use with the AN/FRD-10 Wullenweber system; however, the instrumentation required to produce such a beam by present digital commutation techniques does not appear practical at this time.

Nonoptimum phasing such as that shown in Figure 36 can be programmed by the digital commutator. Experiments to investigate the technique were planned, but, because of equipment difficulties and delays in other portions of the research program, no experiments were carried out. Based upon the results of array thinning, however, it is concluded that antenna spacings greater than 2° to 3° would result in objectionable cogging effects on the CRT display. For a 2° azimuthal spacing, no serious cogging effects are expected since the difference patterns, having a null beamwidth of about 5° , show no apparent cogging on the display pattern (see Figures 20 and 30).

In order for optimum phasing to be practical with digital commutation, each antenna circuit would contain a voltage controlled, variable delay line with digital and/or computer programming. With the rapid advances in on-line computer control techniques and integrated circuit technology, the concept of optimum beaming forming for any cophasal angle is not a technically formidable task nor is it economically impractical.

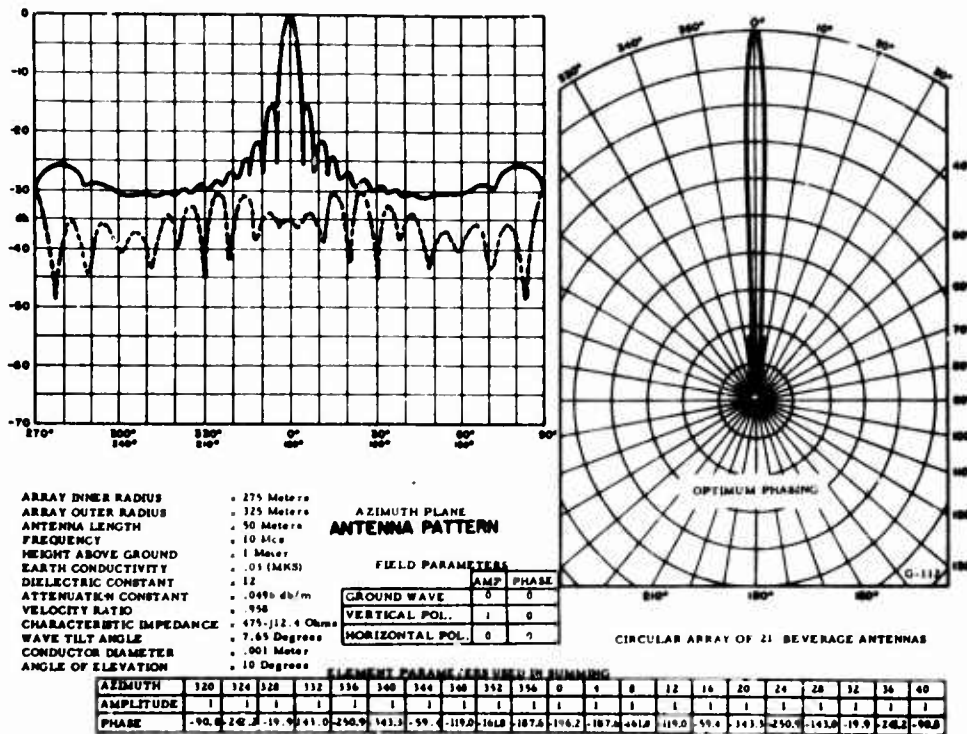

FIGURE 35. OPTIMALLY PHASED ARRAY PATTERN AT 10 MHz - 21 ANTENNAS

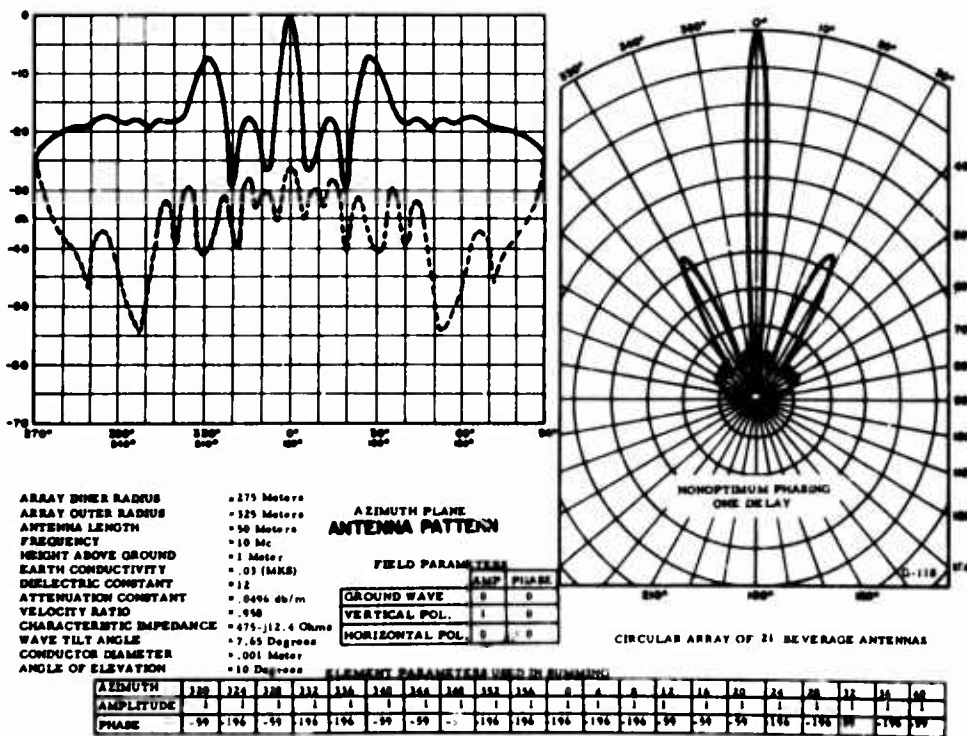

FIGURE 36. NONOPTIMALLY PHASED ARRAY PATTERN WITH ONE DELAY AT 10 MHz - 21 ANTENNAS

G. Performance Tests--Beverage and Doppler Systems

1. Bearing Accuracy

Bearing accuracy tests have been performed on all of the Beverage antenna arrays described in Section III. A. In addition, during the bearing accuracy tests of the Beverage arrays having 75-meter elements, the AN/TRD-15 Doppler system was operated along with at least one of the Beverage antenna DF systems. Portions of each test were conducted so that bearings were taken simultaneously from two systems. Details and results of the accuracy tests are described in Volume II of this report.

2. Bearing Sensitivity

In order to determine the Beverage direction finder performance on signals of varying field strengths, a test was conducted using one Beverage array and the AN/TRD-15 Doppler (the performance of which is known). The only criterion for judgment by the DF operator was: Could a DF bearing be obtained if desired?

Results of tests to compare the bearing sensitivity of the Beverage system to that of the AN/TRD-15 Doppler system are summarized in Table I. The tests were performed as follows:

- (1) The Beverage DF operator tunes through the band beginning at 2 MHz until he obtains a usable DF pattern which, in his judgment, he could record a bearing (he was not required to identify the intercepted signal by call).*
- (2) He then notifies the Doppler DF operator of the frequency and azimuth and any other information to identify the signal (the two receiving systems tracked in frequency within 1 kHz).
- (3) The Doppler operator tunes through the band, also beginning at 2 MHz, until he first obtains a usable DF pattern.
- (4) If the frequency is lower than that of the Beverage, he notifies the Beverage operator of the frequency and azimuth, etc.

*Single sideband signals were not included in the test because the present AN/TRD-15 system could not process the signal.

- (5) The Beverage operator returns to that frequency and determines if an intercept and bearing can be obtained.
- (6) If not, the Doppler operator records the frequency and proceeds up the band until he intercepts the signal [of Step (1)] of the Beverage operator repeating Steps (3), (4), and (5) for any other intercepts. Both operators then record the common intercept. Considerable care was taken to insure that both operators were intercepting the same signal.
- (7) If in Step (3), the frequency was higher than that of the Beverage intercept, the Doppler operator carefully searches the band around the frequency furnished in Step (2). If the correct intercept cannot be made, then only the Beverage operator records the intercept.
- (8) The Doppler operator then proceeds up the band until the next DF pattern is obtained.
- (9) Steps (2) through (7) above are repeated except that the roles of the two operators are reversed.
- (10) Step (8) is repeated with the Beverage operator in the lead position and so on through the frequency range of interest.

Of 160 total intercepts, a bearing could be obtained in 97 instances on the Doppler and 159 instances on the Beverage.

3. High Angle Tests

The performance of the various Beverage arrays and the AN/TRD-15 was observed on simultaneous reception of signals from target transmitters located 34 and 100 miles from the DF site and from cooperative transmissions from members of the MARS network generally located between 79 and 250 miles from the DF site. All signals were constant carrier without modulation.

In the 34-mile test, the Beverage system developed usable patterns only when ground wave was present; however, usable patterns were obtained a greater percentage of the time on the Doppler, particularly when ionospheric conditions were stable. When polarization rotation was evident, which is characteristic of steeply downcoming signals (estimated 75° to 85°), neither system was effective.

In the 100-mile test, useful patterns were obtained on the larger Beverage array A-II with elements at 0.1 meter above ground for signals below about 6.5 MHz. The performance of the small array A-I at 1.0-meter height was judged not useful for DF purposes. Although the Doppler pattern broke up considerably during the tests, whenever the Doppler did "lock-in," the direction was judged to be approximately correct and yielded a useable bearing a greater percentage of the time than did the Beverage system.

The operators observing the tests preferred the Doppler pattern to that of the Beverage because of its characteristic of giving a stable pattern usually only when propagation conditions were favorable and no pattern otherwise. On the other hand, the Beverage pattern fluctuated with polarization variations and demanded more pattern interpretation from the operator as to when to take a bearing.

The above tests were restricted to comparative observations and 16-mm motion pictures of side-by-side displays. Bearing accuracy tests were not conducted since experience had already shown that the pointing accuracy is largely influenced by the ionospheric conditions such as tilts or undulations and is difficult to interpret without ionospheric sounder data. Therefore, the tests were limited to judging pattern quality and how often a useful DF pattern was obtained.

The results of the MARS tests are presented in Volume II of this report (Test No. 4 and the Appendix).

H. Procedure for Beverage Antenna Design for HF DF

The following antenna design procedures are based upon the theoretical and experimental results presented in this report (Volumes I and II) and the reference reports. However, the instrumentation for a direction finder system can vary according to its purpose. Suitable instrumentation is described in Appendix I and Reference 2:

- (1) Specify frequency range $f_{\min} \leq f \leq f_{\max}$

Specify any subrange within f_{\min} and f_{\max} in which array performance should be optimized. $f'_{\min} \leq f \leq f'_{\max}$.

- (2) Select site.*

*High conductivity sites are preferred.

- (3) Measure earth constants σ and ϵ .
- (4) Specify intercept range d , in miles, $d_{\min} \leq d \leq d_{\max}$.
- (5) Specify antenna length L
 - (a) $L = \lambda/2$ at f_{\min} for $200 < d < 600$ miles
 - (b) $L = \lambda/1$ at f_{\min} for $600 \leq d$
- (6) Specify antenna height, $h_{\max} = 1.0$ meter
 - (a) If $f'_{\max} < 5$ MHz, then $0.1 \leq h \leq 0.25$ meter
 - (b) If $f'_{\min} < 5$ MHz and $f'_{\max} > 10$ MHz, then $0.25 \leq h < 1.0$ meter
- (7) Erect a single antenna on site; use copperweld ground rod at each end and wooden interior support stakes. Insulate the antenna from the ground rods at each end; connect a noninductive variable resistor R at one end; connect an impedance transformer (4/1, 6/1 or 10/1, transformation ratio) between antenna and ground at the remaining end.
- (8) Using a swept VSWR technique, adjust the variable resistance R for flat VSWR response over frequency range. Measure value of R . $R \approx$ characteristic impedance of antenna. Unless antenna is on the ground, the VSWR will be approximately constant with frequency.
- (9) Determine average input impedance Z_{in} to transformer by insertion method using known resistive terminations to VSWR bridge.
- (10) If transformer ratio K is known, then $KZ_{in} \approx R$.
- (11) Specify full circular or sector array.
 - (a) Install largest array diameter possible in site selected. Locate antennas along radial with 3° maximum spacing. Height above ground as specified in (6). Terminate all antennas of length L in a resistance $= R$ at the periphery of the array. Connect an impedance transformer to inner ends of all antennas such that $R/K =$ characteristic impedance coaxial feedline (50, 75, 90 or 100 ohms).

- (12) Instrument the array for direction finding and/or intercept operation.*
- (13) If local transmitter signals interfere with normal operation of the instrumentation, design filters having equal input and output impedance equal to R/K .

I. The Beverage Antenna as a Transmitting Antenna

Although the Beverage antenna has low radiation efficiency, its directivity is such that more energy per unit solid angle can be radiated in the direction of beam maximum than from a resonant monopole on or near the earth's surface. The frequency independent characteristic of the Beverage is also an advantage for wideband operation and operation at an optimum frequency to meet propagation conditions.

A transmission test was conducted in December 1965 between the Institute's field site in San Antonio and a remote receiving site in California. Four 75-meter Beverage antennas were used at each end, spaced approximately 2° apart, and less than 1 meter above the ground. The feed of all antennas was connected in parallel to a transmitter (180-watt input to final) operating between 14 and 14.5 MHz. Signal-to-noise ratio at the receiving antennas was greater than +50 dB. An adequate signal was still received after the transmitter power was reduced 10 dB. In a subsequent test, two-way voice communication was established (using the Beverage antennas for transmitting and receiving) with equally good results.

The tests described were conducted after a review of the literature uncovered a report, written shortly after World War II, describing successful operation of the Beverage antenna as a transmitting antenna (around 100 kHz) on Labrador [10]. A single Beverage outperformed a 180-ft top loaded vertical in a direction where the vertical plane contained the Beverage wire.

J. AN/TRD-15 Site Error

Brief tests with a groundwave target have shown that the Doppler system may have serious site error. Tests at four azimuths as a function of frequency are shown in Figure 37. (The indicator was calibrated for zero error at 2.0 MHz). Just how the groundwave site error might influence skywave reception is not known; however, some of the unusually large mean errors in the bearing studies described in Volume II of this report might be accounted for in this manner.

*A complete system design is described in Appendix I and Reference 2.

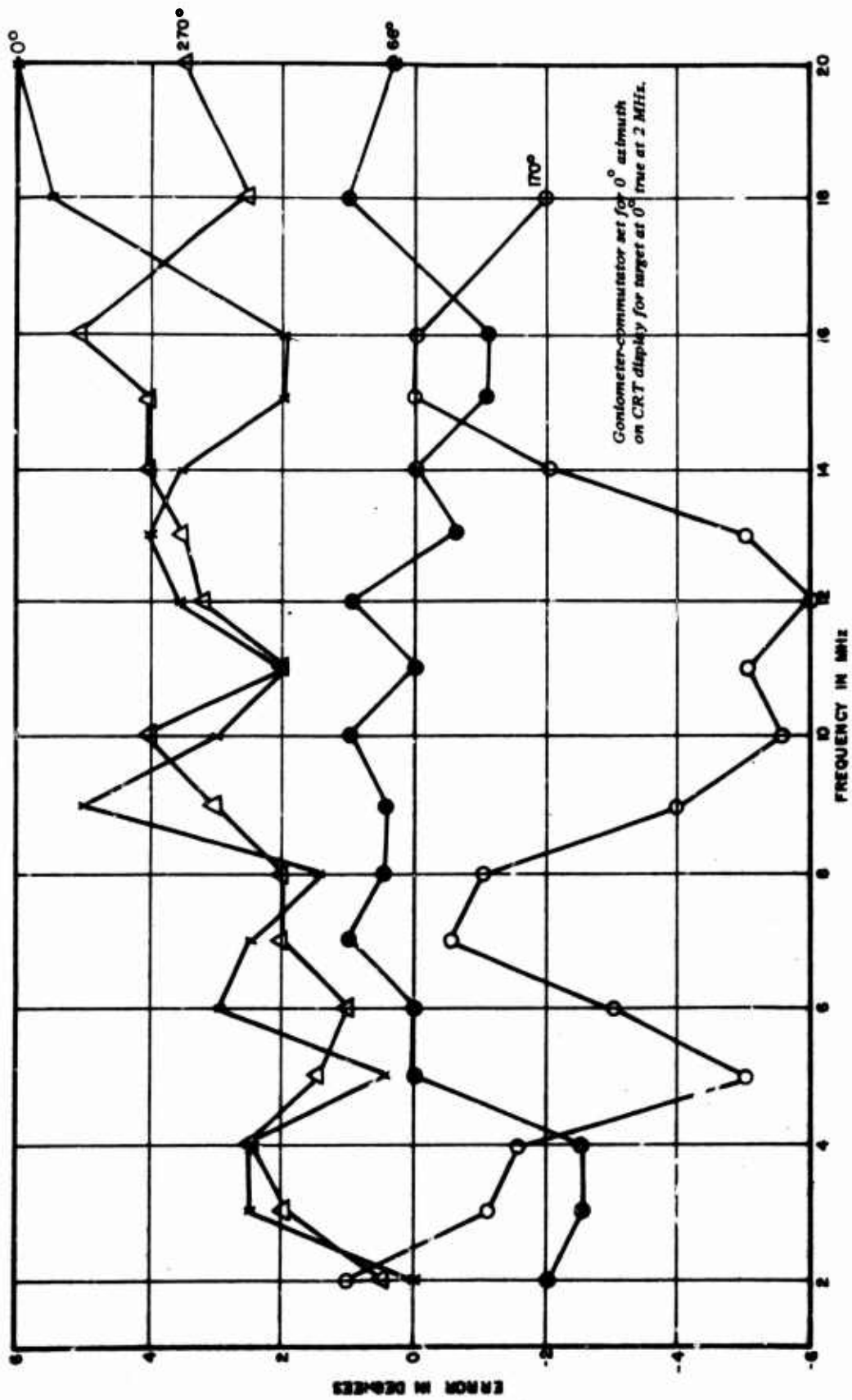

FIGURE 37. AN/TRD-15 BEARING ERROR VS FREQUENCY FOR GROUNDWAVE AT FOUR AZIMUTHS

IV. CONCLUSIONS

In order to meet security requirements for this contract, the final report is divided into Volumes I and II; Volume I containing only unclassified material and Volume II both unclassified and confidential material concerning measured accuracies. For detailed conclusions regarding accuracy, Volume II must be consulted; however, general accuracy conclusions and all others are presented below:

- (1) The currently completed research and development work performed since late 1965 has resulted in extensive performance data on sensitivity, impedance, DF accuracy, array size, antenna height, comparative DF measurements with an AN/TRD-15 for various arrays and, where appropriate, single antennas. An experimental model of a Beverage and intercept system sufficiently complete to permit operational evaluation under field conditions has been delivered.
- (2) Extensive new computer analysis of DF accuracy data has been completed for signals representing all target distance range. The data reveal the optimum application is one using wider apertures (large feedpoint radius), lower antenna element heights and lower elevation angles of arrival. Such conditions produce the best data with experienced operators. It is concluded that Beverage arrays of the type studied to date are an important contribution to applications where very low cost wide aperture performance, tactical or permanent, is appropriate for Wullenweber type commutation and where accuracy performance between Adcocks and conventional wide aperture systems is required.
- (3) Beverage array sensitivities of less than 1.0 microvolt per meter for 10-dB signal plus noise-to-noise ratio with non-phased digital Wullenweber type commutation have been realized in practice. Measured DF bearing sensitivity exceeds that of the AN/TRD-15 (150-ft diameter).
- (4) The digital commutators of the present design are suitable for control and programming by a digital computer. A real time system using adaptive processes would be compatible with the present design and would be the most direct means of utilizing the commutator flexibility in the present design. The commutator permits manual selection of the number of elements

summed or scanned, scan rate, phasing of elements, the array element distribution, amplitude of elements and other design factors usually permanently fixed in a rotating commutator design of the Wullenweber type. Although the present digital design has two rotating elements to provide a clock and sine-cosine sweep for CRT presentation, design details for all electronic digital commutators have been completed. Use of electronic commutation with the AN/FRD-10 instrumentation could be accomplished with very little modification of the existing circuits.

- (5) The present digital commutator design has achieved high element to element isolation, reduction in switching transients below the system noise levels, satisfactory gain in each antenna circuit, and the realization of predicted array gains and beamwidths in practice over the 2 to 30-MHz range. Field experiments have not as yet been performed with digital commutation for external phasing of elements. Beamwidth and sensitivity improvements have been obtained only by the direct summation of antenna inputs; however, the use of two commutators with offset beams and differentially connected outputs (180° phase) has resulted in very narrow null mode patterns. Differential commutation also results in specialized improved performance on skywave signals since a quality null forms only when the received signal field is symmetrical on either side of the boresight path. Such nulls form at nearly the same azimuth regardless of the rate of fade or bearing swing noted on max-type displays.

The extremely narrow beams obtained by capacitive rotating fixed design goniometers in typical Wullenweber systems have not as yet been attempted with digital commutation; however, a design based on voltage variable delay lines (or other digitally controlled techniques) and the present electronic commutator is feasible for adaptive computer control.

- (6) An automatic bearing readout has been incorporated in the delivered digital commutator. The instrumentation provides for either placing an electronic cursor (intensity modulated strobe) over the displayed array pattern or rotating the display until it is bisected by a vertical line on the CRT. In both instances, a digital counter provides a decimal readout of azimuthal rotation of cursor or pattern in degrees relative to true north to 0.1° resolution.

- (7) In general, the Beverage systems investigated are not recommended for direction finding on skywave signals arriving at elevation angles estimated to be greater than 60° to 65° for frequencies greater than 3 to 4 MHz. This is based on a rapid increase of Beverage antenna array polarization error with increasing high elevation angle. When rapid polarization rotation occurs at high angles of arrival, observed bearings tend to follow the polarization ellipse making accurate bearings difficult. However, for lower angles where the antenna response to horizontal polarization is very much less than to vertical, the observed DF patterns fade on bearing.
- (8) Theoretical and experimental research at SwRI since 1961 has shown the Beverage antenna useful as a low cost element over the entire high frequency band over soils of relatively high conductivity (as well as low as is to be expected). The antenna is essentially frequency independent with an endfire unidirectional pattern aperiodically maintained over the 1 to 30-MHz range. The antenna is aperiodic over at least a five-octave frequency range where its length is greater than one-half wavelength. The practical upper frequency limit has not been determined.

The Beverage antenna can be effectively impedance matched by resistive termination with no discontinuity or resonances. The input impedance, almost totally resistive and uniformly flat over the frequency range of interest, can be easily transformed to any standard feed cable impedance with a standing wave ratio of less than 1.25/1. The aperiodic characteristic is an important advantage in the design and operation of direction finder instrumentation (impedance transformers, filters, multicouplers, power dividers and commutators).

- (9) The low profile of the Beverage array is an advantage both from a tactical and an installation cost standpoint. Material cost for an antenna element such as that described in Appendix I (page I-31) is now less than \$40.00. After pre-assembly such as that shown in Figure 13 of Appendix I, installation time for two men is less than 30 minutes per antenna assembly. Although in nearly all installations to date uninsulated copper wire has been used for the antenna, oxide formation on the wire has prevented deterioration in performance as a result of antenna contact with grass or other growth. Test antennas of insulated wire showed no improvement at the SwRI sites.

- (10) The complete mathematical model of the circular Beverage array has been programmed for a digital computer. A vast amount of data has been calculated to investigate the effects of various earth constants antenna lengths, height above ground multielement summation, array phasing and array geometry might have upon the field patterns (azimuth and polar) as a function of frequency and wave polarization. The phase characteristic of the antenna pattern as a function of azimuth, elevation and frequency permits conventional design of phased arrays for optimally narrow beamwidths where appropriate.
- (11) The engineering design of the Beverage antenna array can be adjusted to meet specific site requirements. The antenna need not be greater than one wavelength long (one-half wavelength will produce a slight sacrifice in front to back ratio) or greater than 1 meter above the ground. For a fixed array size, reduced beamwidth and increased sensitivity is realized by using short antennas and a large feedpoint radius rather than long antennas with a short feedpoint radius.

The loss in single element sensitivity as the element length is decreased can be quickly overcome by arraying of elements for minimum beamwidths because more elements can be arrayed with the shorter elements than longer ones before deterioration in beamwidth is noted.

The optimum method would be to place the feedpoints at the outer end of the antenna; however, the improvement does not appear to justify the increased cost of feed cables. On the other hand, an increase in array utilization efficiency by a factor of two can be realized if the antenna is fed at each end. No directivity problem exists if the feed cable and commutator circuits (or multicouplers) terminate the antenna since the antenna is directional away from the feedpoint towards the terminated end. It should be noted that dual independent commutation is required.

As the antenna height is decreased to zero, the antenna sensitivity increases at the lower frequencies but decreases more rapidly at the higher frequencies. A good compromise is about 0.5 meter.

- (12) Because of its directivity, the Beverage antenna is a useful transmitting antenna either singly or arrayed. Its aperiodic characteristic permits wideband coupling to the transmitter.
- (13) Pattern interpretation is much easier on a 10-in. display area such as the AN/FRD-10 indicator than on a 4-in. area of the IP 137 indicators. Side lobe symmetry is more readily recognized on the larger display providing indication of minimum horizontally polarization. In addition, the AN/FRD-10 display of only the detected video rather than video plus sub-carrier common to the IP 137 indicator aids pattern interpretations by the DF operator.
- (14) Reviewing previous reporting, the wave or Beverage antenna is a resistively terminated horizontal transmission line using the earth in the return circuit. The antenna is erected on or just above the surface of the earth and operates in the traveling wave mode. Under conditions which are easily realizable at practical sites, it is an aperiodic antenna exhibiting an end-fire unidirectional radiation pattern with a maximum in a direction along the wire away from the receiving end or towards the terminated end.

The attenuation increases and velocity ratio decreases as the antenna height approaches zero (attenuation and velocity ratio both increase with increase in frequency). The attenuation factor is an advantage because (1) the line appears to approach an infinity long characteristic from the input terminals as frequency increases, (2) the effect of reflections from the terminating resistor (in practice, the exact characteristic impedance is not realized) is reduced, thereby improving the front to back ratio, (3) the effect of the attenuation factor is to reduce the active region (effective electrical length) of the antenna toward the feedpoint end as frequency increases which improves the antenna performance over a wider frequency range.

V. RECOMMENDATIONS

1. An operational evaluation (or equivalent testing) of the transportable Beverage Direction Finder System should be conducted.
2. Development of the digital commutator should be continued to provide: (1) external array phasing by digital methods to approximate Wullenweber operation, (2) miniaturization using integrated circuits, (3) development of control logic for operation and programming by a digital computer leading toward an adaptive system, (4) Doppler scanning of circular arrays as an option, (5) optional sector scanning and sum and difference scanning.
3. Applicability of the antenna array to hardened sites should be pursued with an engineering design.
4. The theory of Beverage antennas over poorly conducting soils should be improved.
5. DF performance on poor sites which might be available in tactical situations should be determined. This should include terrain irregularities, conductivity discontinuities, stratified earth sites, and forested areas.

VI. LIST OF REFERENCES

1. Douglas N. Travers and Ray E. Cooper, "Use of the Beverage Antenna in Wide Aperture High Frequency Direction Finding," Interim Report No. 5 for Contract NObsr-85364 dated 7 February 1962. Part I of IV parts describing and summarizing Beverage antenna research at Southwest Research Institute.
2. Douglas N. Travers, et al., "Use of the Beverage Antenna in Wide Aperture High Frequency Direction Finding (Part II: System Design)," Interim Report No. 4 for Contract NObsr-89345 dated 1 August 1964. (Part II of IV parts describing and summarizing Beverage antenna work at Southwest Research Institute.)
3. Douglas N. Travers, Paul E. Martin and W. M. Sherrill, "Use of the Beverage Antenna in Wide Aperture High Frequency Direction Finding [Part III: Bearing Accuracy (U)]," Interim Report No. 3A for Contract NObsr-89345 dated 23 March 1964 (CONFIDENTIAL). Part III of IV parts describing and summarizing Beverage antenna research at Southwest Research Institute.
4. Douglas N. Travers, Paul E. Martin and W. M. Sherrill, "Use of the Beverage Antenna in Wide Aperture High Frequency Direction Finding (Part IV: Theory)," Report No. 3B for Contract NObsr-89345 dated 23 March 1964. Part IV of IV parts describing and summarizing Beverage antenna research at Southwest Research Institute.
5. Paul E. Martin, et al., "An Experimental Beverage Antenna Array for Land Based Direction Finding between 1.5 and 30 Mc," Final Report for Contract DA 36-039-AMC-02346(E), Southwest Research Institute, 30 June 1964.
6. Paul E. Martin, "The Beverage Direction Finder," Final Development Report for Contract NObsr-85364, Southwest Research Institute, 14 June 1963.
7. Paul E. Martin and Douglas N. Travers, "Circular Arrays of Beverage Antennas for High Frequency Direction Finding," Interim Development Report No. 6 for Contract NObsr-89345, Southwest Research Institute, 31 December 1964.

8. Paul E. Martin and Richard Lorenz, "Circular Arrays of Beverage Antennas for High Frequency Direction Finding," Interim Development Report No. 9 for Contract NObsr-89345, Southwest Research Institute, 31 January 1966.
9. Paul E. Martin, et al., "Circular Arrays of Beverage Antennas for High Frequency Direction Finding," Interim Development Report No. 7 for Contract NObsr-89345, Southwest Research Institute, 15 April 1965.
10. Abstract No. 2903, Abstracts of the Available Literature on Radio Direction Finding 1899-1965, prepared by Southwest Research Institute for Contracts NObsr-64585, NObsr-85086 and NObsr-89167, 1 July 1966.

APPENDIX I

INSTRUCTION MANUAL
FOR
TRANSPORTABLE DIRECTION FINDER SET
USING
A CIRCULAR ARRAY OF
BEVERAGE ANTENNAS
(2-30 Mc)

1. TABLE OF CONTENTS

	<u>Page</u>
1. TABLE OF CONTENTS	I-1
2. LIST OF ILLUSTRATIONS	I-4
3. LIST OF TABLES	I-8
4. INTRODUCTION	I-9
4.1 Scope	I-9
4.2 Descriptive Data	I-9
4.2.1 General	I-9
4.2.2 Antenna and Array	I-10
4.2.3 Instrumentation	I-10
4.2.4 Systems Application	I-10
4.2.5 Basic Principle	I-16
4.2.6 Technical Characteristics	I-16
4.2.7 Applicable Literature	I-18
4.2.8 Definitions	I-18
4.2.9 Nomenclature Assignments	I-18
4.2.10 Recommended Laboratory Instruments	I-20
5. DETAILED SYSTEM DESCRIPTION	I-21
5.1 Beverage Antenna Array	I-21
5.2 Electrical Equipment	I-32
5.2.1 Electrical Equipment Cabinet No. 1	I-32
5.2.2 Electrical Equipment Cabinet No. 2	I-32
5.2.3 Azimuth Indicator	I-34
5.2.4 Radio Receiver	I-34
5.2.5 Goniometer Chassis	I-34
5.2.6 Digital Commutator	I-34
5.2.6.1 Ring Counter	I-37
5.2.6.2 Logic Control Circuits	I-37
5.2.6.3 RF Gate Switch or Gate	I-37
5.2.7 Cables	I-38
5.3 Shelter	I-38
6. INSTALLATION	I-39
6.1 General Installation Instructions	I-39
6.2 Uncrating, Unpacking and Checking Equipment	I-39
6.3 Site Selection	I-39

1. TABLE OF CONTENTS (Cont'd)

	<u>Page</u>
6.3.1 Technical Requirements for Good Site	I-39
6.3.1.1 Area	I-39
6.3.1.2 Obstacles	I-42
6.3.1.3 Site Preparation	I-42
6.4 Array Orientation and Layout	I-42
6.5 Location of Shelter and Array Center	I-43
6.6 Location of the 0° Antenna Element	I-44
6.7 Ground Rod Location at the Array Inner Radius	I-45
6.7.1 Method I - Location by Transit Level and Chain	I-45
6.7.2 Method II - Two-Transit Technique	I-46
6.7.3 Method III - Location by Chord Measurement	I-49
6.8 Installation of Antenna Elements	I-52
6.9 Installation of High Pass Filters	I-57
6.10 Installation of Electronic Equipment	I-58
6.11 Installation of Interconnecting Cables	I-58
6.12 Installation of Filter Panel to Commutator Cables	I-58
6.13 Installation of 60-Hz Power	I-63
7. OPERATING INSTRUCTIONS	I-65
7.1 Power	I-65
7.2 Circle Adjust of IP 137/GRD - Refer to Figure 16	I-65
7.3 Methods of Azimuthal Bearing Determination	I-66
7.3.1 Mechanical Alidade	I-66
7.3.2 Strobe Slew or Strobe Rotation Option	I-66
7.3.3 Pattern Slew or Pattern Rotation Option	I-67
7.4 Operation of Commutator - Refer to Figures 28 and 29	I-67
7.5 Initial System Checkout, Test and Calibration	I-70
7.6 Formation of the Antenna Beam	I-72
7.6.1 DF Mode Operation	I-72
7.6.2 Intercept Mode Operation	I-73
8. SYSTEM CHECKOUT PROCEDURE	I-79
8.1 Array Alignment and Circuit Check	I-79
8.2 Test Procedure for Incorrect or Inoperative Circuit	I-80
8.3 System Calibration	I-81
8.3.1 Mechanical Alidade	I-82
8.3.2 Electronic Alidade with Strobe Rotation	I-82
8.3.3 Electronic Alidade with Pattern Rotation	I-83

1. TABLE OF CONTENTS (Cont'd)

	<u>Page</u>
9. ADJUSTMENTS, MAINTENANCE AND TROUBLESHOOTING	I-84
9.1 IP 137/GRD Chassis (Modified)	I-84
9.2 Digital Commutator	I-86
9.2.1 RF Chassis	I-87
9.2.1.1 Adjustment for Minimum Switching Transient	I-87
9.2.1.2 Gain Adjustment	I-89
9.2.2 Ring Counter	I-94
9.2.3 Logic Control and Bearing Readout Circuits	I-95
9.3 Goniometer Chassis Modification	I-98
9.4 Troubleshooting	I-98
9.5 System Performance Tests	I-127
10. MISCELLANEOUS	I-132
10.1 Shipping Lists	I-132
10.2 Antenna Components for One Antenna Circuit	I-132
10.3 Spare Parts	I-132
11. GENERAL INSTRUCTIONS AND PLANNING FOR BEVERAGE SYSTEM	I-136
11.1 Basic Instructions	I-136
11.2 Operating Instructions	I-138
WORK SHEETS	I-141

2. LIST OF ILLUSTRATIONS

<u>Figure</u>		<u>Page</u>
1	Partial Plan of Circular Beverage Array	I-11
2	Sketch of Beverage Antenna Assembly	I-12
3	Sector View of Circular Array of Beverage Antenna	I-13
4	Typical Installation of Elements	I-14
5	Electronic Instrumentation	I-15
6	Block Diagram of Beverage DF System	I-17
7	Beverage Antenna Array and Electronic Equipment Shelter	I-22
8	Cross Section of One Antenna Circuit	I-23
9	Details of Feedpoint Assembly	I-24
10	Details of Termination at Outer Radius	I-25
11	Antenna Termination Details	I-26
12	Details of Antenna Transformer	I-27
13	Complete Antenna Assembly	I-28
14	High Pass RF Filter	I-29
15	Transistor RF Gate	I-30
16	Front View Electronic Cabinets	I-33
17	Rear View Electronic Cabinets	I-35
18	Goniometer and Optical Shaft Encoder Chassis	I-36
19	Representative Installation at Array Center	I-40

2. LIST OF ILLUSTRATIONS (Cont'd)

<u>Figure</u>		<u>Page</u>
20	Antenna Reel Storage Boxes and Location with Respect to Shelter	I-41
21	Alignment Procedures for Two-Transit Technique	I-47
22	Layout Device for Chord Measurement	I-51
23	Chord Measurement Chart	I-54
24	Relative Location of Equipment Racks 1 and 2 within Shelter	I-59
25	Interconnecting Cable Diagram	I-60
26	Filter Panel to Commutator RF Cabling	I-61
27	RF Chassis - Rear View	I-62
28	Ring Counter and Master Control Chassis	I-68
29	Ring Counter and Master Control Chassis - Rear View	I-69
30A	Examples of Display Calibration and Pattern Rotation	I-71
30B	Beverage Array Pattern for WWV	I-74
30C	Beverage Array Patterns	I-75
30D	Beverage Array Patterns	I-76
30E	Beverage Array Patterns	I-77
30F	Beverage Array Patterns	I-78
31	Modified Circuit of IP 137 Azimuth Indicator	I-85
32	RF Drawer Extended	I-90

2. LIST OF ILLUSTRATIONS (Cont'd)

<u>Figure</u>		<u>Page</u>
33	Test Circuit for RF Gain Adjust	I-91
34	Block Diagram - One Commutator Stage	I-91
35	Ten-Stage Example of Ring Counter Circuits	I-96
36	Digital Logic Board for Twelve Stages of Ring Counter	I-96
37	Ring Counter Chassis	I-97
38	Block Diagram of Master Control Chassis	I-99
39	Logic Diagrams for Master Control Boards 1 and 2	I-101
40	Logic Diagrams for Master Control Boards 3 and 4	I-102
41	Logic Diagrams for Master Control Boards 5 and 6	I-103
42	Logic Diagram for Master Control Boards 7 and 8	I-104
43	Logic Diagrams for Board No. 9 of Master Control and Representative Ring Counter Board	I-105
44	Commutator Master Control Chassis	I-109
45	Logic Board No. 1 - Master Control Chassis	I-110
46	Logic Board No. 2 - Master Control Chassis	I-111
47	Logic Board No. 3 - Master Control Chassis	I-112
48	Logic Board No. 4 - Master Control Chassis	I-113
49	Logic Board No. 5 - 0-3599 Strobe Position Counter	I-114
50	Logic Board No. 7 - Binary to Decimal Decoder and Lamp Driver	I-115
51	Logic Board No. 8 - Binary to Decimal Decoder and Lamp Driver	I-116

2. LIST OF ILLUSTRATIONS (Cont'd)

<u>Figure</u>		<u>Page</u>
52	Logic Board No. 9 - Master Control Chassis	I-117
53	Welded Module Specifications	I-118
54	Schematics of Special Logic Circuits	I-119
55	Commutator Timing Diagram	I-121
56	Oscilloscope Traces of Pulse Test Points	I-123
57	Oscilloscope Traces of Pulse Test Points	I-124
58	Mount and Drive Assembly for Optical Shaft Encoder	I-125
59	Fuse Locations and AC Power Connections	I-126
60	Sensitivity and Noise Figure Measurements for R390/URR	I-129
61	Field Strength for 10-dB Signal-Plus-Noise to Noise Ratio versus Frequency	I-130
62	Signal Gain versus Number of Elements in Array	I-131
63	Antenna Hardware Shipping Crates	I-134

3. LIST OF TABLES

<u>Table</u>		<u>Page</u>
I	Beverage Antenna Array Components	I-31
II	Location of Consecutive Antennas by Chord Locator	I-53
III	Running List for Filter-Commutator Cables	I-64
IV	Wiring Lists for Ring Counter Stages to RF Switch	I-92
V	Wiring Lists for Master Control Chassis	I-106
VI	Shipping List for Beverage Antenna Hardware	I-133
VII	Spare Parts for Beverage DF System	I-135
VIII	Layout Chart for Beverage Antenna System	I-142

4. INTRODUCTION

4.1 Scope

This manual contains instructions for the installation, operation and maintenance for an experimental model, transportable, wide aperture radio direction finder system using a circular array of Beverage antennas and digital commutation designed and assembled by Southwest Research Institute at San Antonio, Texas. Instructions and recommendations are included for the following:

- (1) Site selection,
- (2) Installation of antenna elements,
- (3) Installation and operation of the electronic equipment,
- (4) Check-out procedures required to assure correct operation of the system,
- (5) Operating procedure, and
- (6) Basic troubleshooting.

All equipments necessary to operate the direction finder set are included in the delivered system with the exception of a shelter for the electronic equipment, 120-volt 60-cycle power unit and test equipment.

4.2 Descriptive Data

4.2.1 General

The Beverage radio direction finder set is a complete transportable wide aperture radio direction finding system that covers the frequency range of 2 to 30 mc with facility for direction finding, intercept reception, communications reception, and frequency measurement. The Beverage antenna array has flexibility to meet widely varying field conditions to provide complete azimuthal or selected sector coverage as desired¹. It is intended for fixed station radio direction finding and intercept on either ground wave or sky wave signals. A typical installation using the Beverage antenna array

¹ Only radio direction finder and intercept modes of operation using full circular arrays will be discussed in these instructions.

and ancillary equipment is sketched in Figure 1. The electronic equipment is housed in a shelter (not furnished) located centrally to the circular antenna array.

4.2.2 Antenna and Array

The Beverage antenna element is a single wire terminated transmission line, using the earth as the return circuit, that is installed parallel to and just above the earth's surface. One end of each antenna element is terminated by a resistance (terminated end) to ground (earth), while the remaining end (feedpoint) is terminated with an impedance transformer to transform the antenna impedance of 470 ohms (nominal) to 75 ohms for a coaxial feedline to the instrument shelter. A sketch of one antenna assembly is shown in Figure 2.

The antenna array is composed of 180 horizontal wire antennas 75 meters in length, located parallel to and 0.25 meter (10 inches) nominal above the earth's surface. A sketch of the relative antenna positions with respect to the equipment shelter was shown in Figure 1; a photograph of a section of a circular array is shown in Figure 3 and typical installation of two elements in Figure 4.

4.2.3 Instrumentation

The DF instrumentation shown in Figure 5 includes modified parts and components from an AN/TRD-4A DF set and various laboratory-built parts with some commercial subassemblies. A cathode ray tube (CRT) indicator in conjunction with a solid state digital commutator is used for DF determinations (aural maximum indication is used for intercept operation). The CRT display has positive bearing sense at all times.

Transistor switches (RF Amplifier-Gates) in each antenna circuit may be operated manually for intercept or driven by the electronic system for DF operation and is adaptable for use by relatively unskilled operators. A 115-volt 60-cycle power source is required for operation of the DF set (not furnished).

4.2.4 Systems Application

One direction finding set can intercept and determine the bearing of the transmitter. Bearings to individual transmitting stations are logged in degrees azimuth to determine a fix on a transmitter. Simultaneous signals on the same frequency may be separated as long as the azimuthal separation between arriving signals is at least a few degrees.

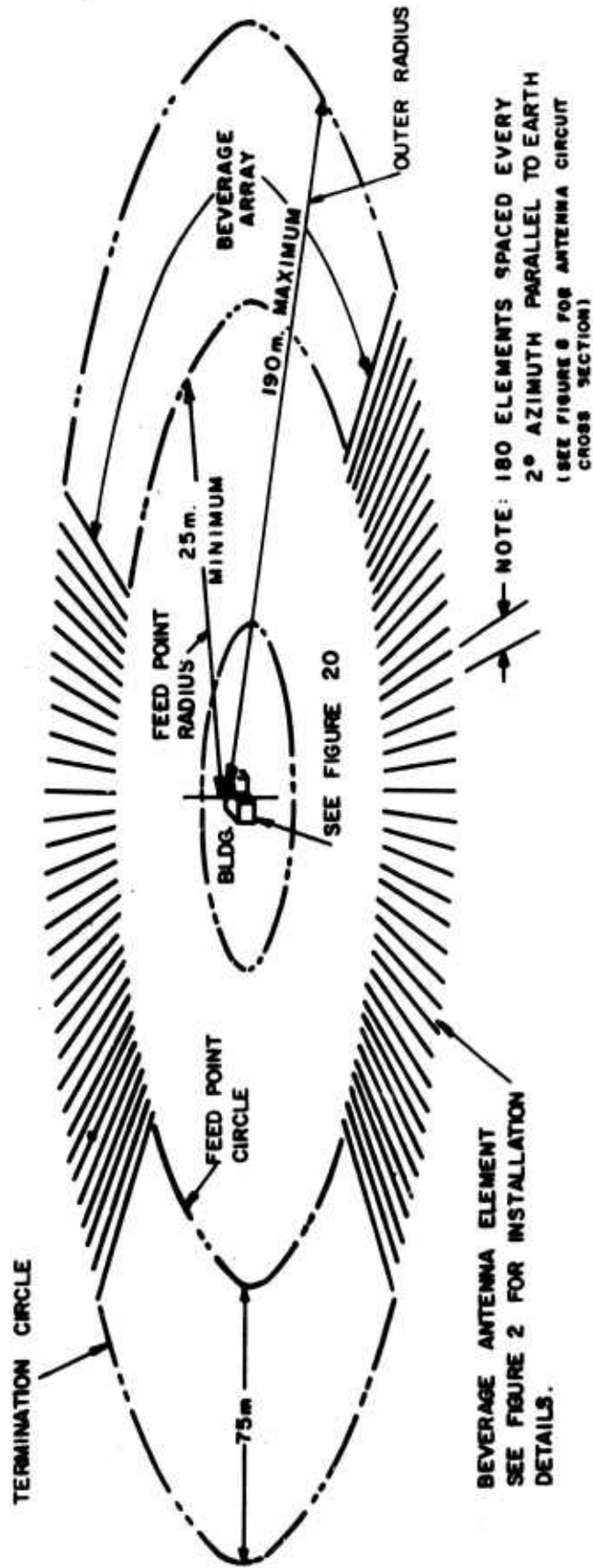

FIGURE 1. PARTIAL PLAN OF CIRCULAR BEVERAGE ARRAY

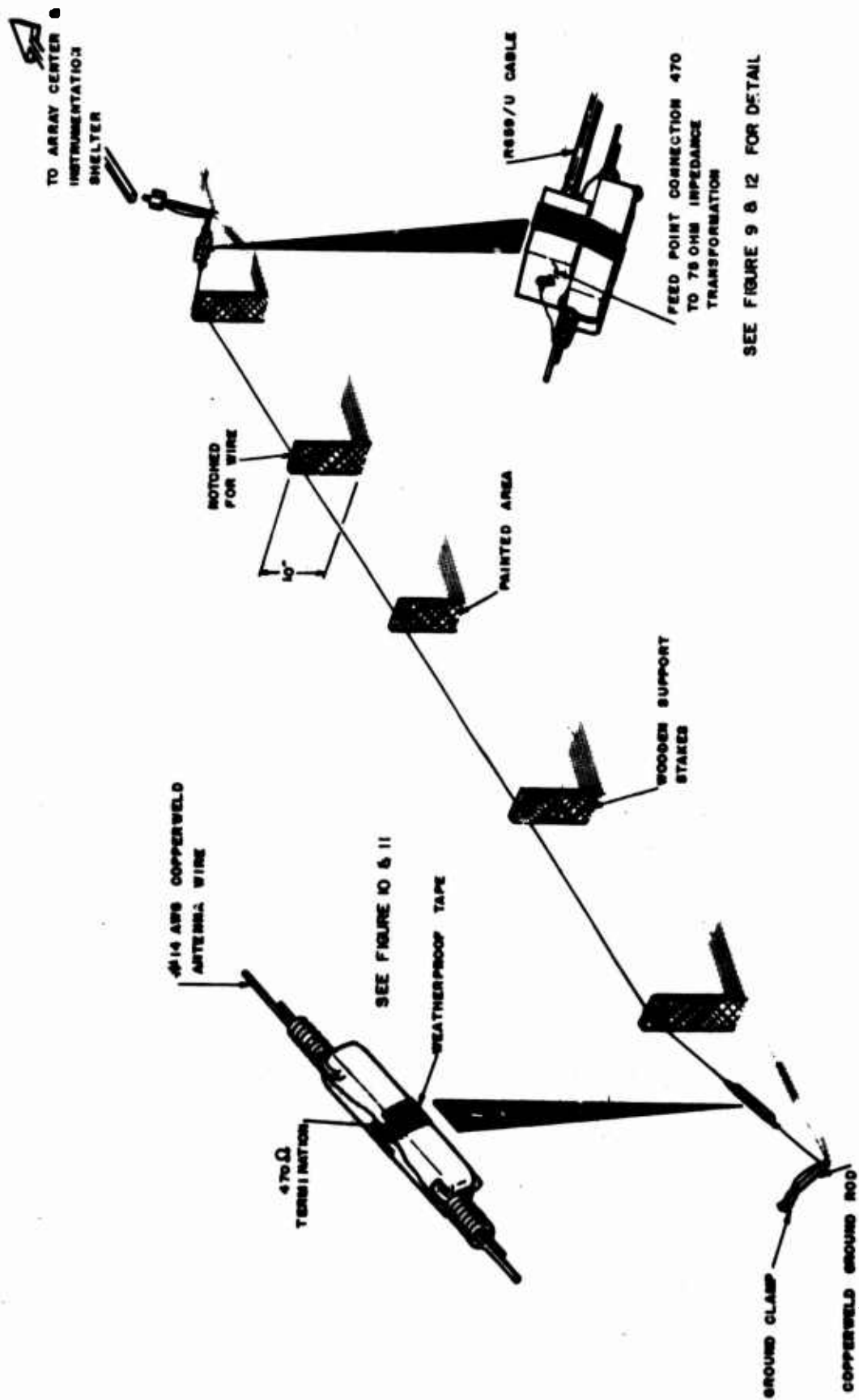

FIGURE 2. SKETCH OF BEVERAGE ANTENNA ASSEMBLY



FIGURE 3. SECTOR VIEW OF CIRCULAR
ARRAY OF BEVERAGE ANTENNA



FIGURE 4. TYPICAL INSTALLATION OF ELEMENTS

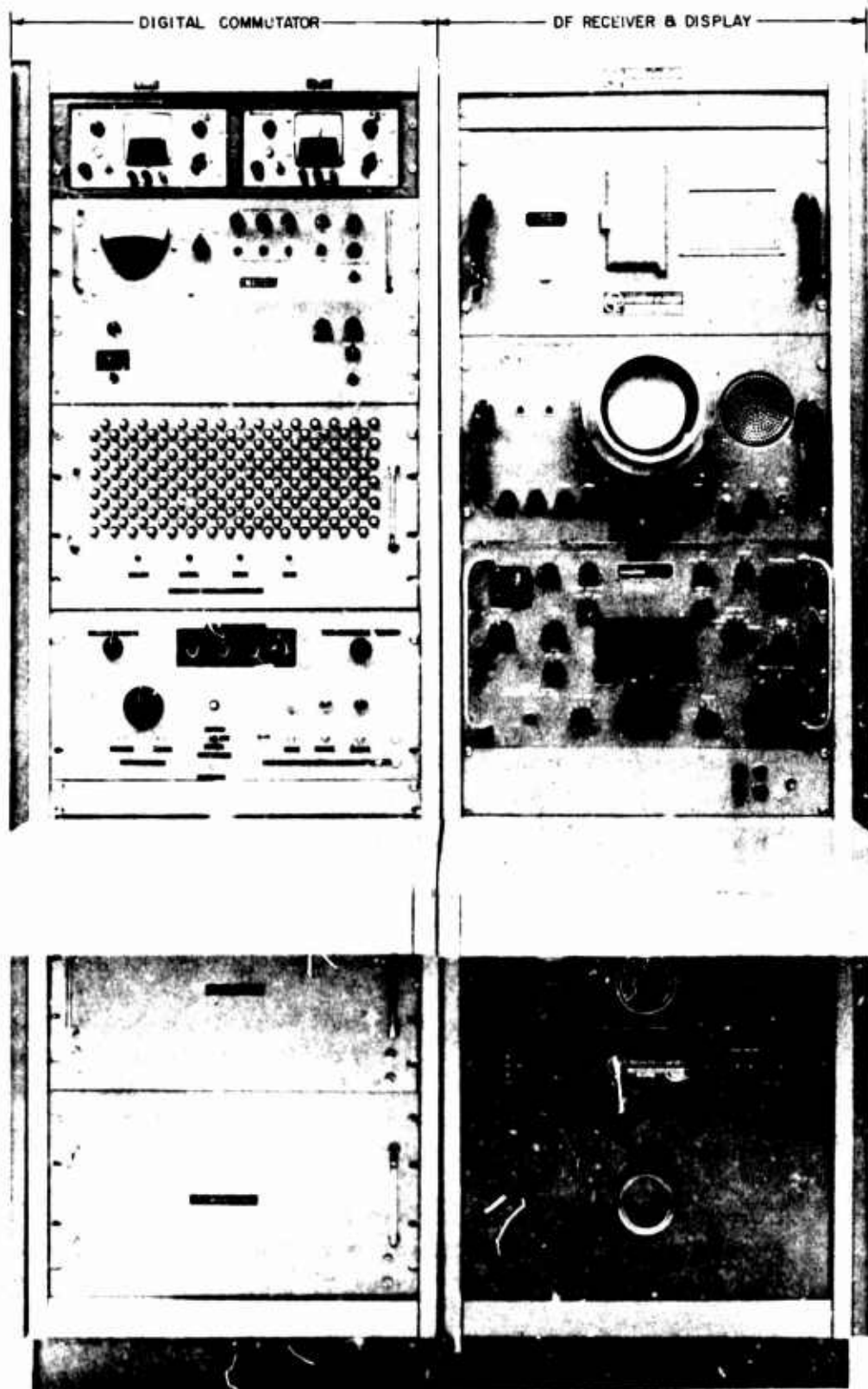

FIGURE 5. ELECTRONIC INSTRUMENTATION

4.2.5 Basic Principle

The Beverage antenna array is sequentially scanned with a multi-input beam forming digital commutator. The number of antennas used to form a beam and their relative azimuthal positions can be selected as desired by the DF operator. A monitor receiver is tuned to the desired frequency for the signal from which a bearing is desired. The electronic system generates a CRT polar display that presents a synthesized pattern of the antenna beam formed by the commutator. The CRT is observed, and the azimuth direction to the transmitting station is read directly from a mechanical alidade (see TM-11-688) mounted in front of the CRT or via an automatic bearing digital readout. A block diagram of the system is shown in Figure 6. Details of the beam-forming electronics, typical CRT patterns, and bearing determination system are given in Section 7.

4.2.6 Technical Characteristics²

- (1) Frequency range: 2 to 30 MHz.
- (2) Site area requirements: Minimum 100 × 100 meters;
Maximum 200 × 200 meters.
- (3) Antenna: Horizontal wire type - terminated transmission line; length - 75 meters No. 14 AWG copperweld wire; height above ground - 0.25 meter.
- (4) Principle of operation: Traveling wave mode utilizing the energy contained in the component of a vertically polarized signal that lies in the plane of incidence and parallel to the ground.
- (5) Array orientation: Recommended azimuthal spacing between antenna elements is 2°. The most frequently used antenna array is a circular array composed of 180 elements located radially from a common center at the equipment shelter with a positive radius for the feedpoint end of each element.
- (6) Commutation: Electromechanical - motor driven optical shaft encoder provides 3600 pulses per shaft revolution, to drive 180-stage digital shift-register ring counter, each stage of

²The specifications stated are typical for the system furnished. Other array dimensions, antenna length and height above ground and frequency of operation, etc., can be adjusted to meet specific requirements. See Final Report ContractNObsr 89345 to be published July 1967.

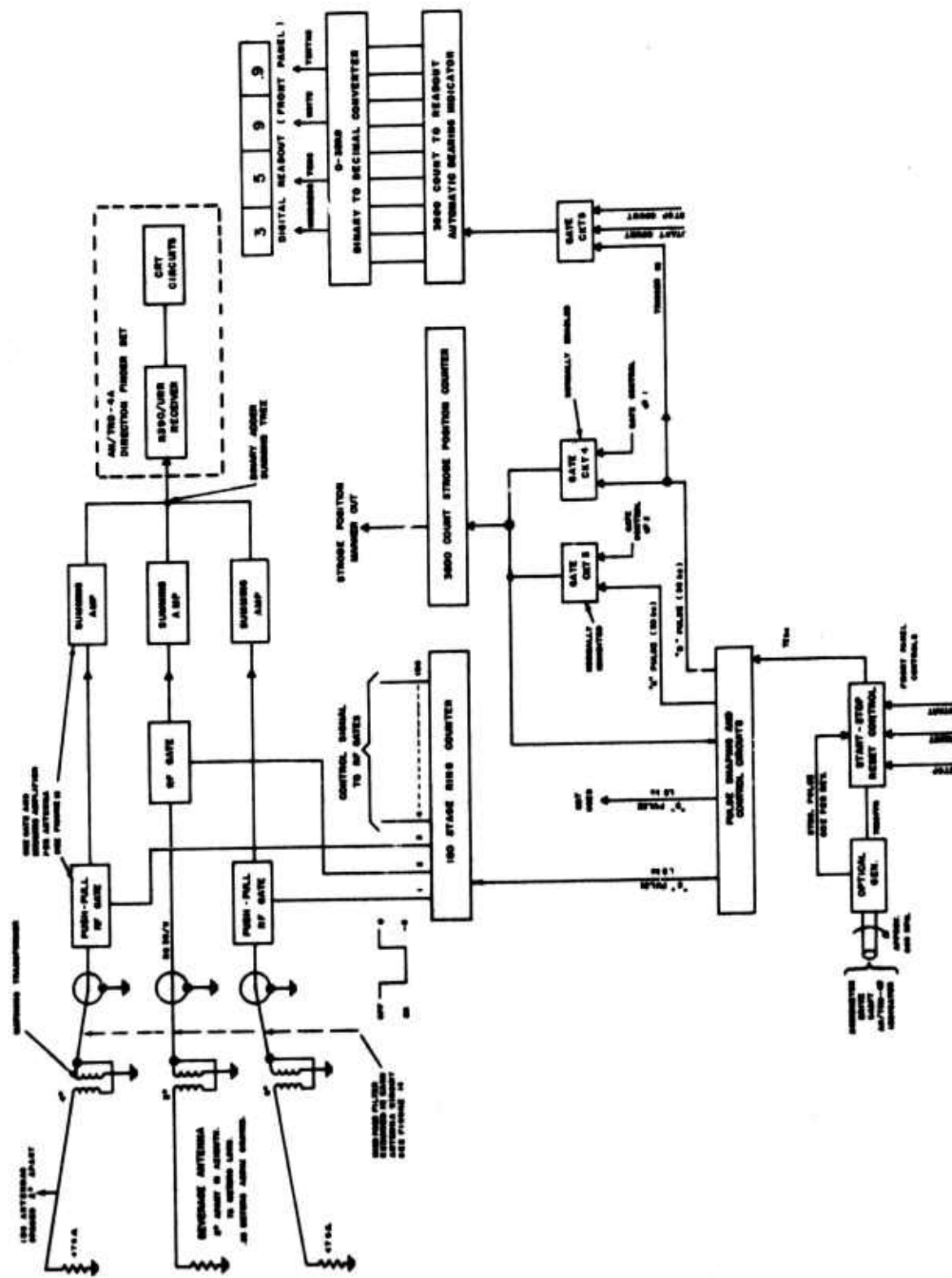

FIGURE 6. BLOCK DIAGRAM OF BEVERAGE DF SYSTEM

which controls the on-off state of a specific transistor gate in a specific antenna circuit.

- (7) Accuracy: Instrumental accuracy of the system furnished is less than 0.25°.
- (8) Radio receiver: R390/URR.
- (9) Power input requirements: less than 1500 watts, 115 volts, single phase 60 Hz without heater or air conditioner (both heater and air conditioner are recommended, however).

4.2.7 Applicable Literature

For complete coverage, the following additional instruction literature is required:

- (1) TM-11-688 for information pertaining to DF set AN/TRD-4A.

NOTE: The IP 137/GRD indicator has been modified for Beverage use.

- (2) TM-11-856 covering radio receiver R390/URR.
- (3) "An Experimental Beverage Antenna Array for Land Based Direction Finding between 1.5 and 30 mc," U. S. Army Contract No. DA 36-043 AMC 02346(E), Southwest Research Institute, Final Progress Report, 30 September 1964. (Describes theory of operation of the Beverage antenna array and electronic equipment; development of the theory of the antenna is described in detail in Appendix F of the report.)
- (4) Instruction book for the Nobotron power supply Model 225-200B.
- (5) Instruction book for Kepko Power Supplies.
- (6) Instruction book for Wayne George Optical Shaft Encoder.

4.2.8 Definitions

Refer to TM-11-688.

4.2.9 Nomenclature Assignments

Throughout this manual, a component may be referred to either by nomenclature or its common name as follows:

<u>Nomenclature</u>	<u>Common Name</u>
Beverage Antenna Array	Antenna Array, Beverage Array
Beverage Antenna	Antenna, Element, Antenna Element
High Pass Filter	HP Filter, Filter, Antenna Filter
RF Switch	RF Gate, RF Amplifier - Gate, Antenna Gate, RF Switch
Solid State Digital Commutator	Commutator, Digital Commutator
Shift Register Ring Counter	Ring Counter
Radio Receiver R390/URR	DF Receiver, Intercept Receiver, Communications Receiver, R390
Azimuth Indicator (Mod) IP 137/GRD	Azimuth Indicator, Indicator, CRT Display
Bearing Indicator	Bearing Indicator, Decimal Readout, Electronic Bearing Indicator
Electronic Bearing Marker	Electronic Alidade, Strobe, Cursor
Indicator Goniometer	Goniometer, Gonio
Optical Shaft Encoder	Optical Pulse Generator, Clock, Trigger Source
Synchronizing Pulse	Sync Pulse, Sync, Zero Sync
Shelter	Shelter
Electronic Equipment	Instrumentation
Electronic Equipment Cabinets	Relay Racks, Racks, Cabinets
Test Pulse Generator	Test Generator, Slow Clock

4.2.10 Recommended Laboratory Instruments³

- (1) Signal Generator - HP 606A or AN/URM 25D.
- (2) Dual Beam Oscilloscope - Tektronix 551 or equivalent.
- (3) True RMS Voltmeter - Ballentine 320A.
- (4) Multimeter - Simpson Model 260.
- (5) Sweep Generator - Telonic SM 2000 with LH2M Head and XD-4A detector.
- (6) VSWR Detector - Telonic TRB-1 with 1/1, 1.2/1, 1.5/1, 1.8/1 and 2.0/1 calibrated mismatches.
- (7) Noise Figure Meter - Kay Model 3000.
- (8) Attenuators - Kay 31-0.
- (9) Test Generator - (Furnished).
- (10) VTVM-RCA WV98C.

A surveyors transit and measuring chain are required but not furnished for installation of the antenna array.

³Equivalent instruments are available for all that are listed.

5. DETAILED SYSTEM DESCRIPTION

5.1 Beverage Antenna Array

- (1) The Beverage antenna system consists of 180 horizontal antennas radially positioned around an equipment shelter as sketched in Figure 7. Each antenna is held in position by two ground rods, one at each end of the antenna, and five wooden support stakes (Figure 2). The circles of ground rods determine the inner and outer array radius. The radial spacing between antenna elements is generally 2° but may be 1° , 3° , 4° , or 6° ⁴. The ground rods anchoring the inner ends of the antennas form a circle of control radius with respect to the electronic system in the shelter.
- (2) The physical size of the Beverage antenna array will be determined by the site selected. Minimum outer radius the system furnished that can be used is 100 meters (328 feet) from the center of the shelter to the outer ground rods for any antenna element. The maximum outer radius is 190 meters (620 feet).

NOTE: The system performance is improved as the array size (radius) is increased; therefore, the largest possible array that can be installed in a particular location is strongly recommended.

The exact array size is not critical, but, once selected, parameter measurements that can be used to check the accuracy of the installation are given in a nomogram. The instructions are based upon the installation of a complete circular array with elements evenly spaced in the azimuth and conforming to the physical lengths determined from the nomograph as measured from the center of the array beneath the shelter.

- (3) To effectively cover the frequency range of 2 to 30 MHz, the antenna is furnished with an impedance matching antenna transformer at the inner end of the antenna element and a 470-ohm terminating resistor at the outer end that is connected to a

⁴If a 1° azimuthal spacing is desired, a 180° sector only may be erected with the equipment and components furnished; however, certain other adjustments are required that are beyond the scope of this manual.

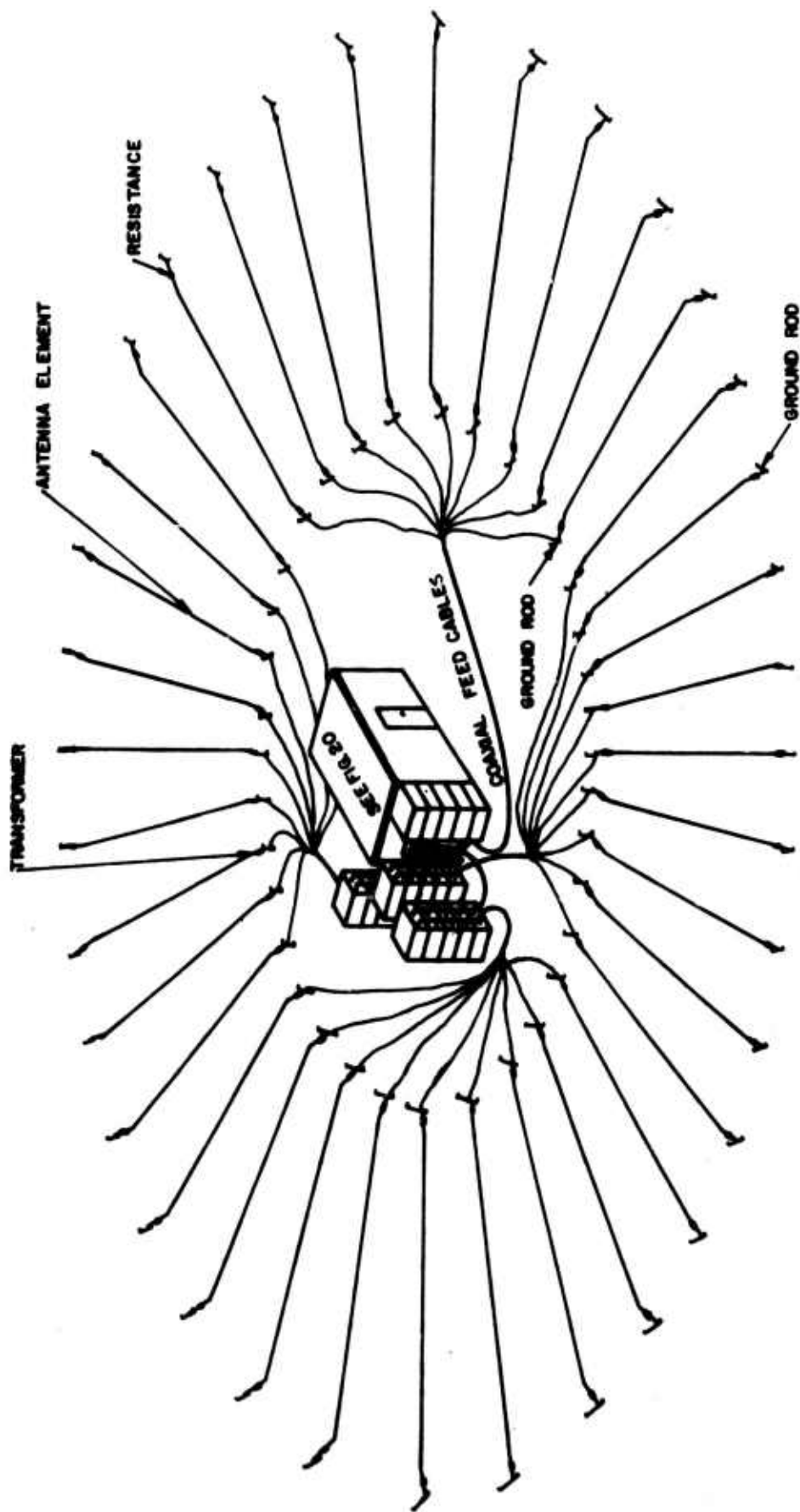

FIGURE 7. BEVERAGE ANTENNA ARRAY AND ELECTRONIC EQUIPMENT SHELTER

ground rod. The VSWR at antenna feedpoint is less than 1.25/1 for the frequency range of 2 to 32 MHz.

- (4) Each antenna element is connected to the processing equipment through a 127-meter length of RG59/U coaxial cable that extends between the antenna transformer and the equipment shelter. Each coaxial feed cable is connected to a specific high pass filter marked to correspond to a given antenna number and/or azimuth.

CAUTION: All cables have been phase matched to the same electrical length; therefore, it is important not to whip, jerk or otherwise stretch the cables during installation.

- (5) Details of an antenna circuit are shown in Figures 2 and 4 and 8 through 15, and the components for one antenna circuit are tabulated in Table I. (A block diagram of the complete system was shown in Figure 6.) Figures 2 and 4 show a typical installation of an antenna element, and Figure 8 is a schematic cross section of a complete antenna circuit.

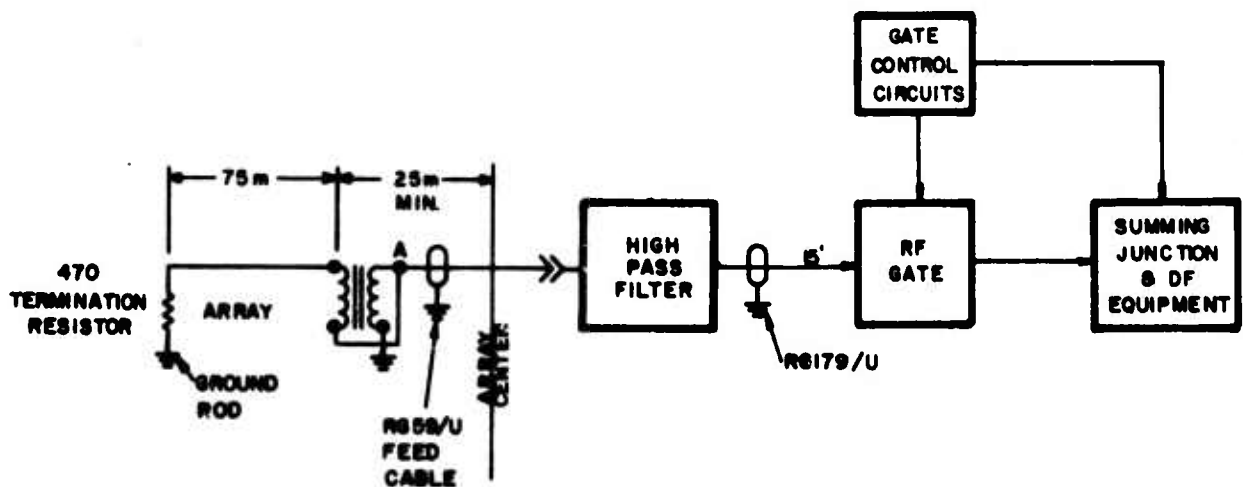

FIGURE 8. CROSS SECTION OF ONE ANTENNA CIRCUIT

Figures 9 and 10 are detail views of the antenna terminations and ground connections - feedpoint with matching transformer and termination end with 470-ohm resistors, respectively. Figures 11 and 12 show the termination assemblies in greater detail. A complete antenna assembly, including feed cable and reel, ready for installation, is shown in Figure 13. Details

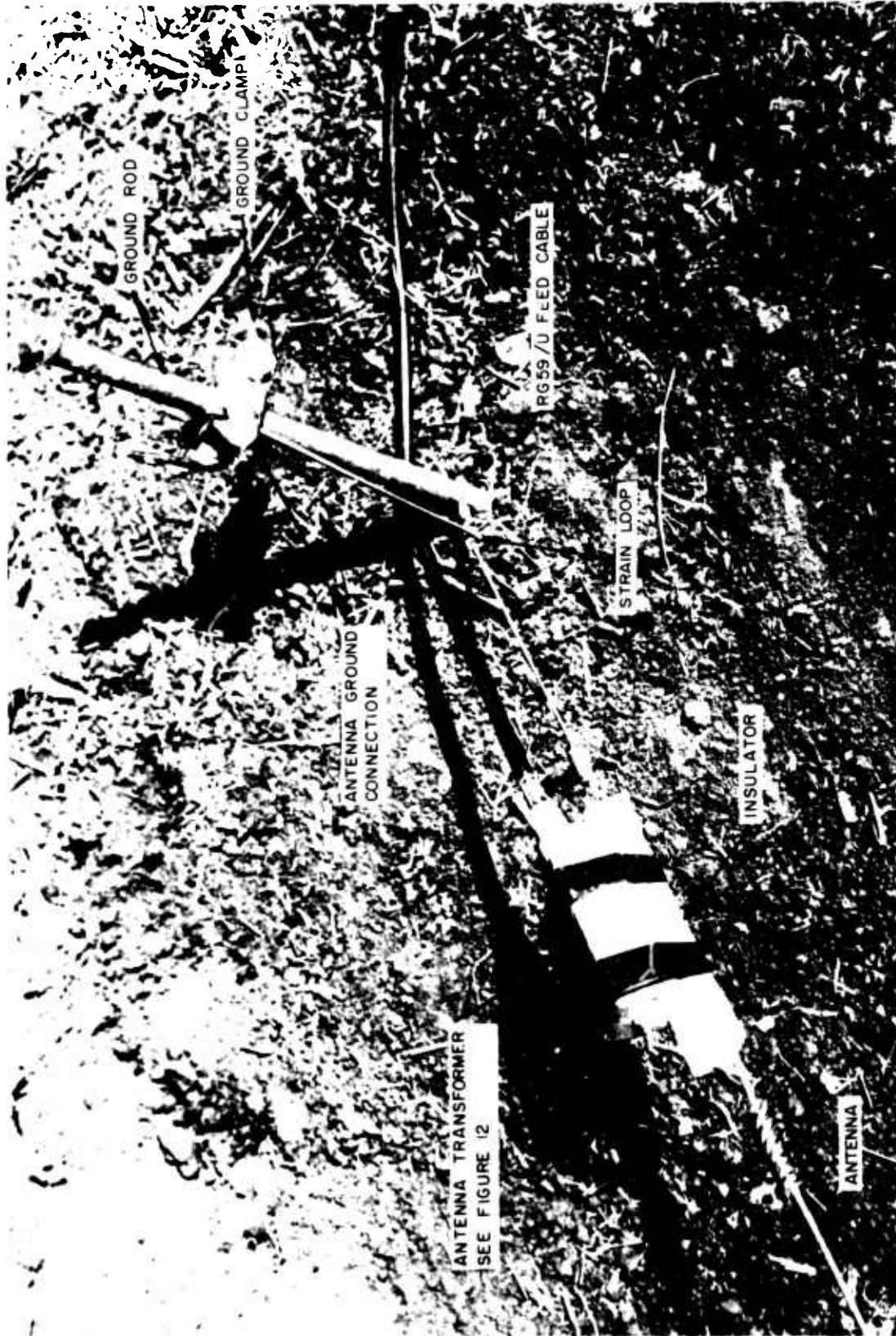

FIGURE 9 DETAILS OF FEEDPOINT ASSEMBLY



FIGURE 10. DETAILS OF TERMINATION AT OUTER RADIUS

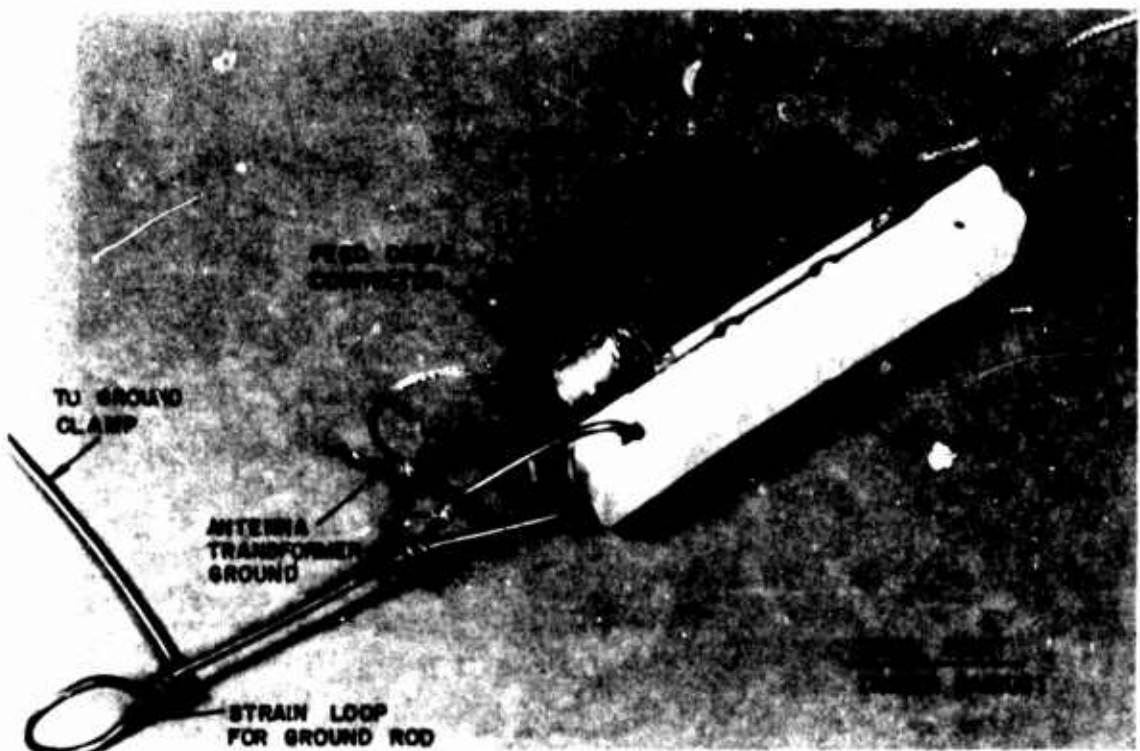
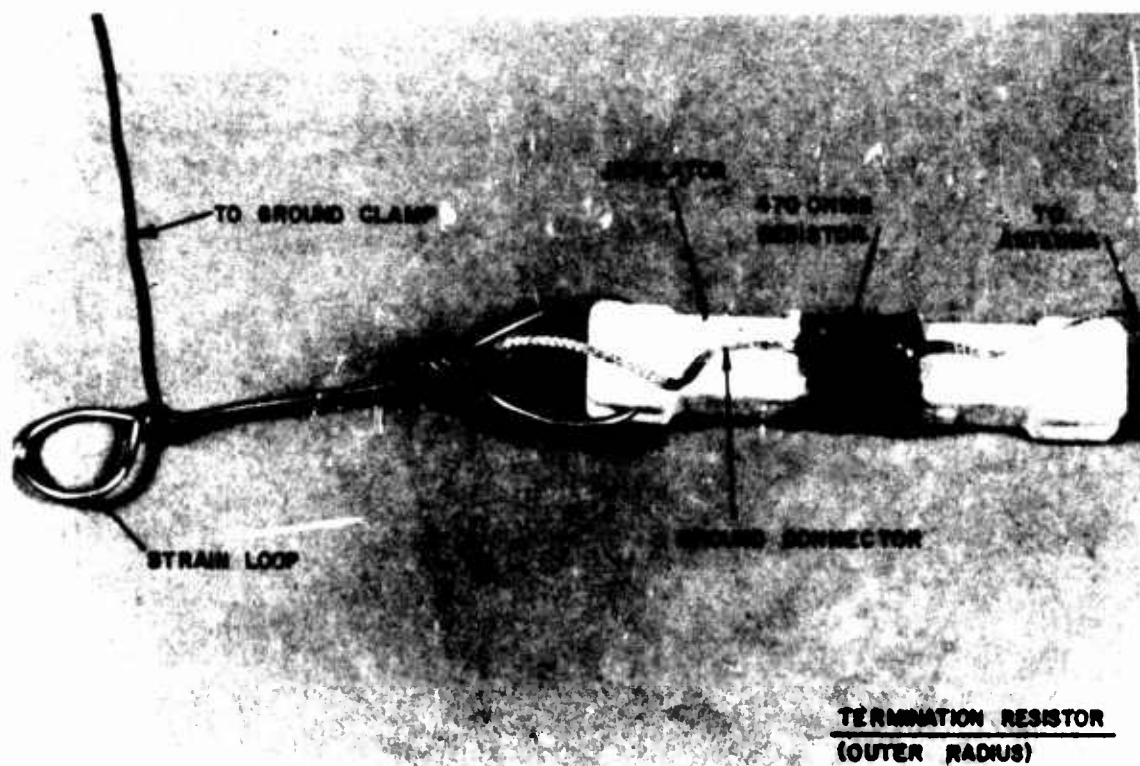
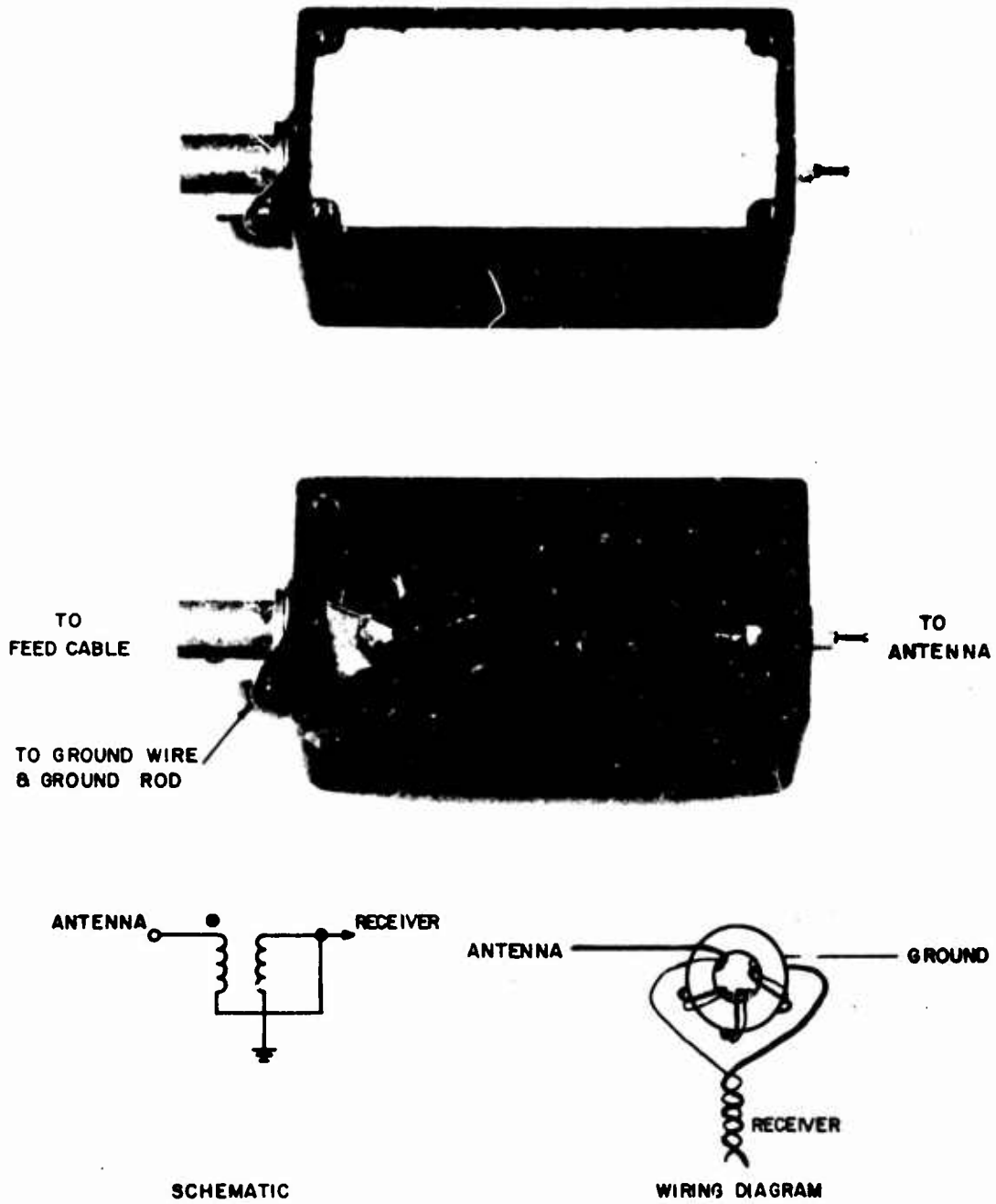

FIGURE 11. ANTENNA TERMINATION DETAILS



TORROID .300 O.D. x .125 I.D.
 FERROKUBE CORP. NO. 286T125/52

FIGURE 12. DETAILS OF ANTENNA TRANSFORMER

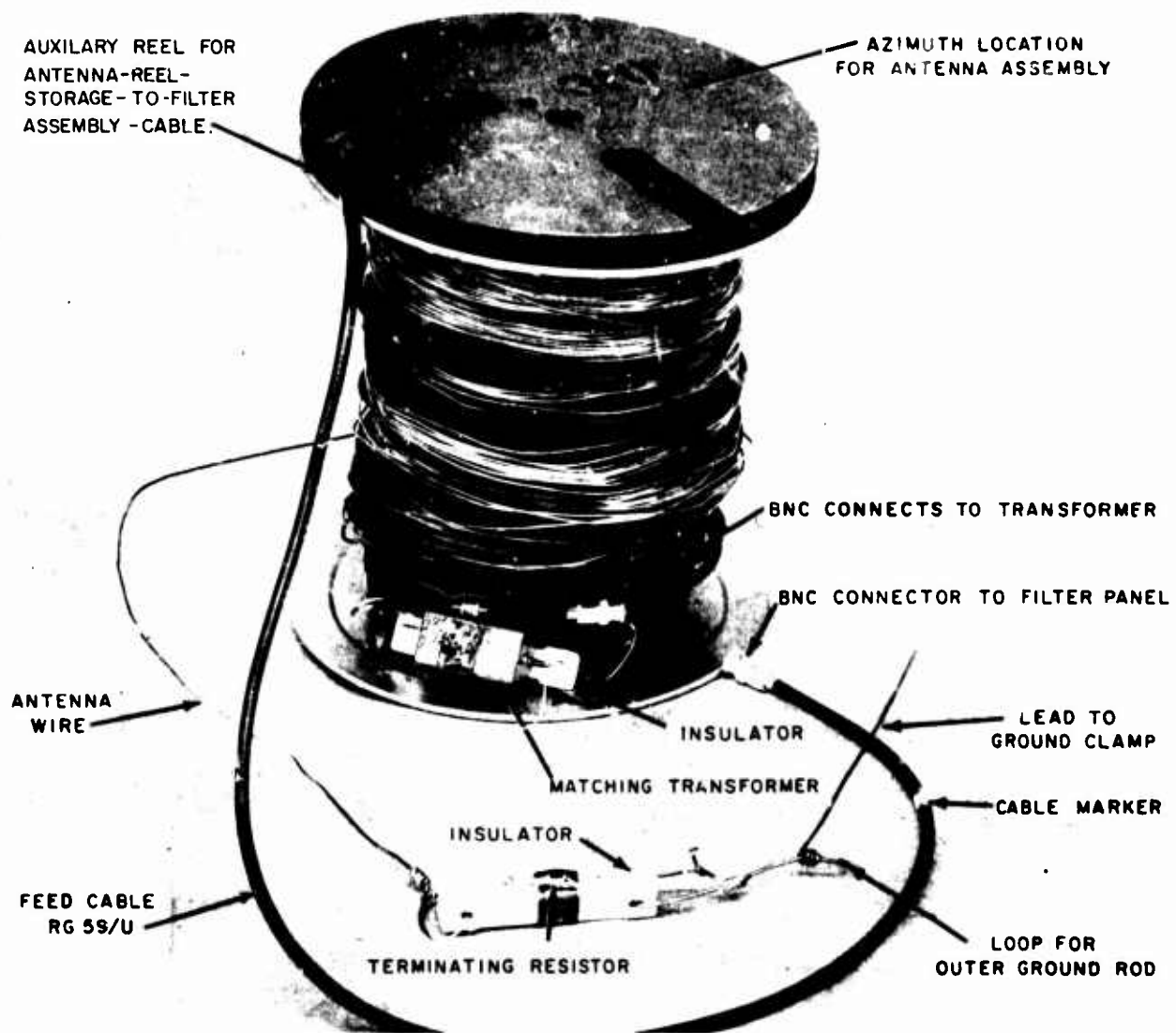

FIGURE 13. COMPLETE ANTENNA ASSEMBLY

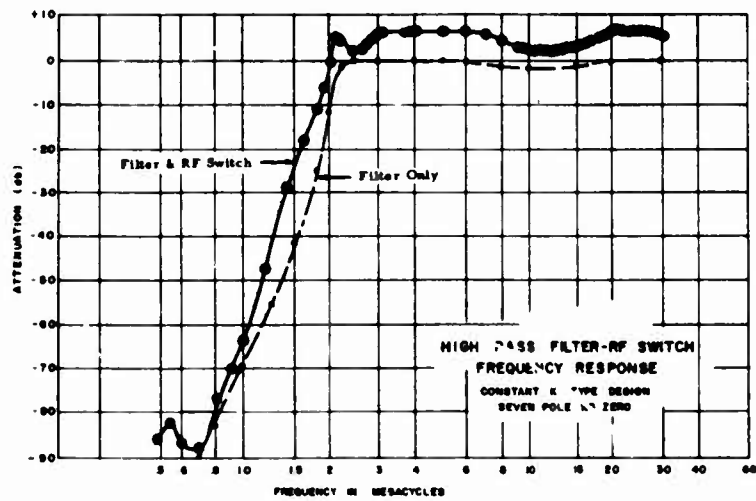
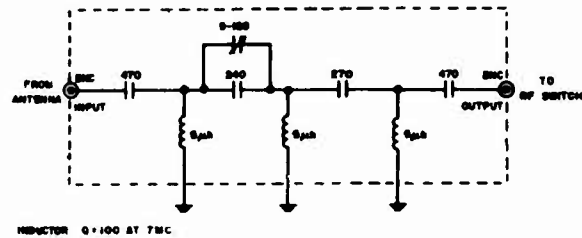
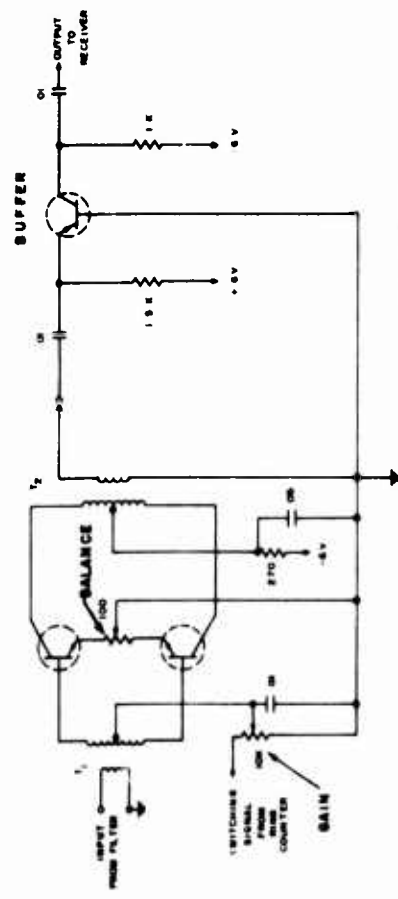
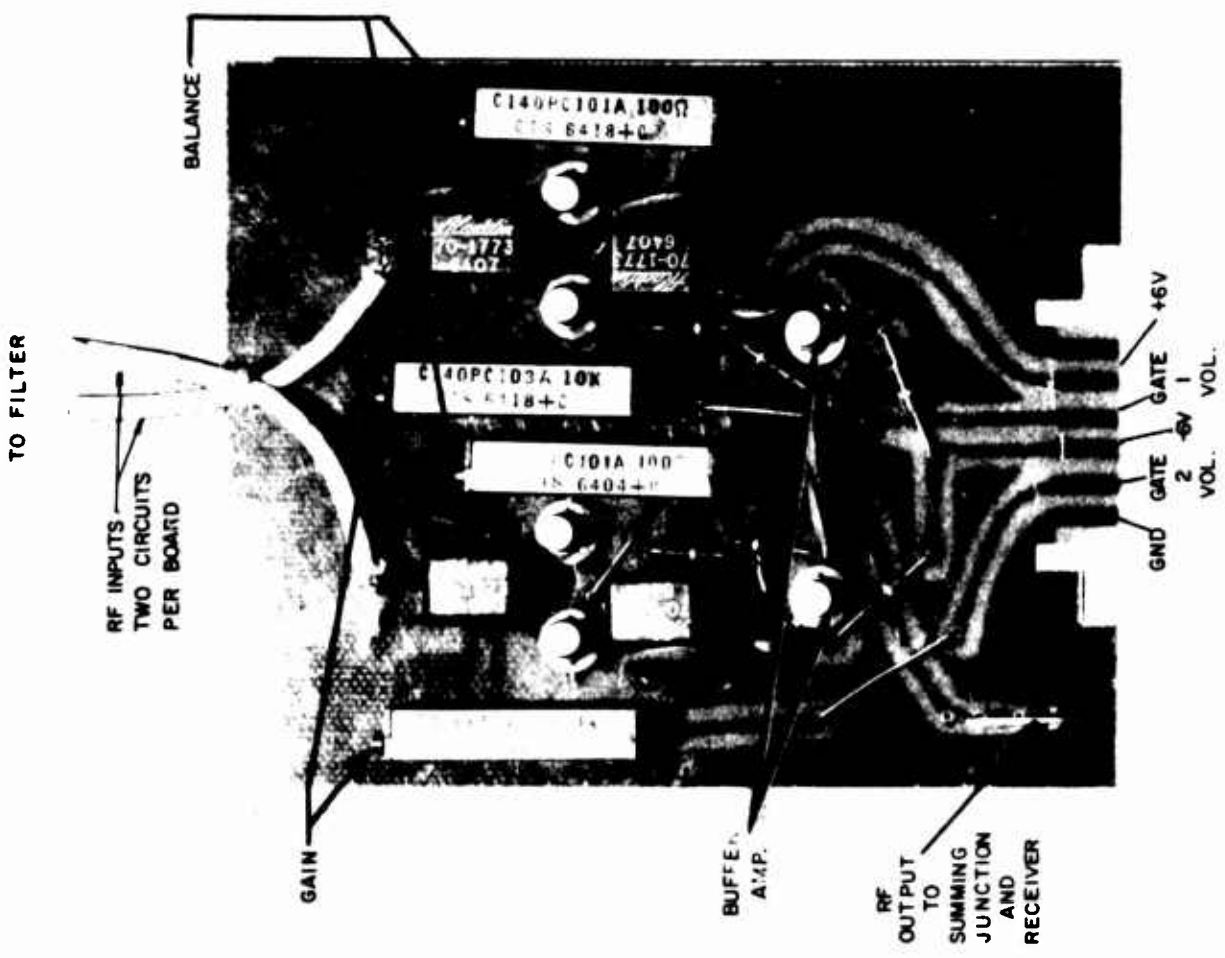

FIGURE 14. HIGH PASS R. F. FILTER



TRANSMITTER - 287119
 T₁, T₂ AL-3004 TYPE 70-1773 6407

SCHEMATIC DIAGRAM, RF SWITCH

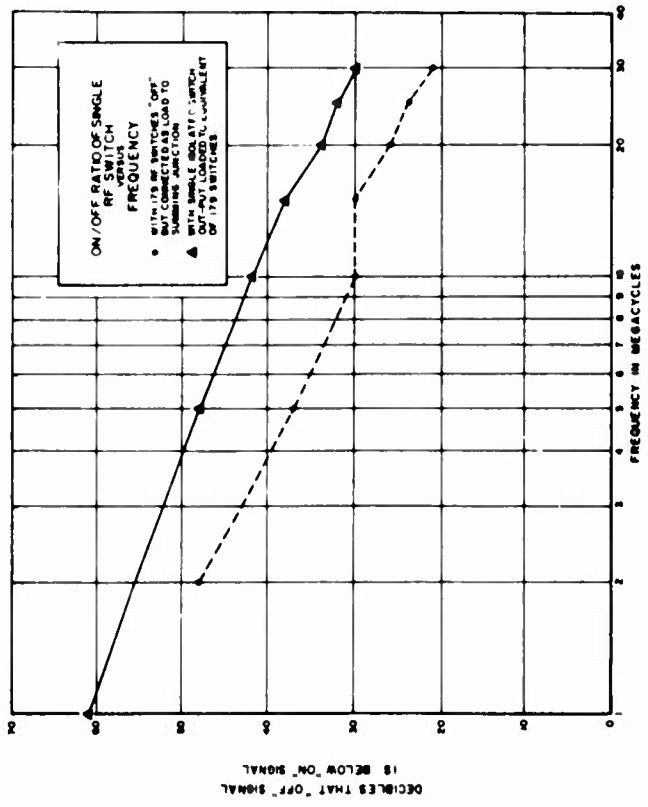

FIGURE 15. TRANSISTOR RF GATE

TABLE I. BEVERAGE ANTENNA ARRAY COMPONENTS

Antenna wire No. 14 AWG copperweld annealed wire	75 meters
Copperweld ground rods 1/2-inch diameter X 36 inches	2 each
Ground clamps	2 each
Johnson insulators type 104	2 each
470 - 1W - 10-percent terminating resistor	1 each
Transformer torroid - Ferroxcube (4-turns bifilar wound No. 32 Formvar)	1 each
Transformer box - Pomona No. 2397	1 each
RG 59/U coaxial cable	127 meters
BNC UG 260 B/U connectors	2 each
BNC bulkhead fitting	3 each
Filter components - torroids (3), capacitors (4), printed circuit board, box	1 set
RG 179/U coaxial cable	5 meters
1-inch X 2-inch X 15-inch wooden support stakes	5 each
Miscellaneous parts, potting compound, terminals, ground terminals, tape	

of the high pass filter are shown in Figure 14 and of the transistor RF gate in Figure 15.

5.2 Electrical Equipment

The instrumentation described in the block diagram of Figure 6 is contained in two equipment racks shown in Figure 16. The cabinets are constructed of reinforced steel frame approximately 21 inches wide, 72 inches high and 25 inches deep with rear access doors and side panels that may be removed for access to the equipment during installation and/or servicing. It is recommended that the doors and panels be kept in place during operation.

5.2.1 Electrical Equipment Cabinet No. 1

The equipment shown in Cabinet No. 1, Figure 16 from top to bottom is as follows:

- (1) Indicator goniometer and optical generator chassis (modified).
- (2) IP 137/GRD azimuth indicator chassis (modified) with power supply.
- (3) R390/URR radio receiver.
- (4) Power supply panel.
- (5) Voltage regulator with voltage and frequency meters, and master power switch for 60-cycle power to all equipments.

5.2.2 Electrical Equipment Cabinet No. 2

The equipment shown in Cabinet No. 2, Figure 16, from top to bottom is as follows:

- (1) Two Kepco Model ABC-7, 5-2 power supplies.
- (2) Electronic Module Corp. Model 0631.5 power supply.
- (3) Technipower Model MP/19.2-6.0 power supply and commutator AC power switch.
- (4) Beam forming control (shift register ring counter) panel with indicators and beam forming switches.

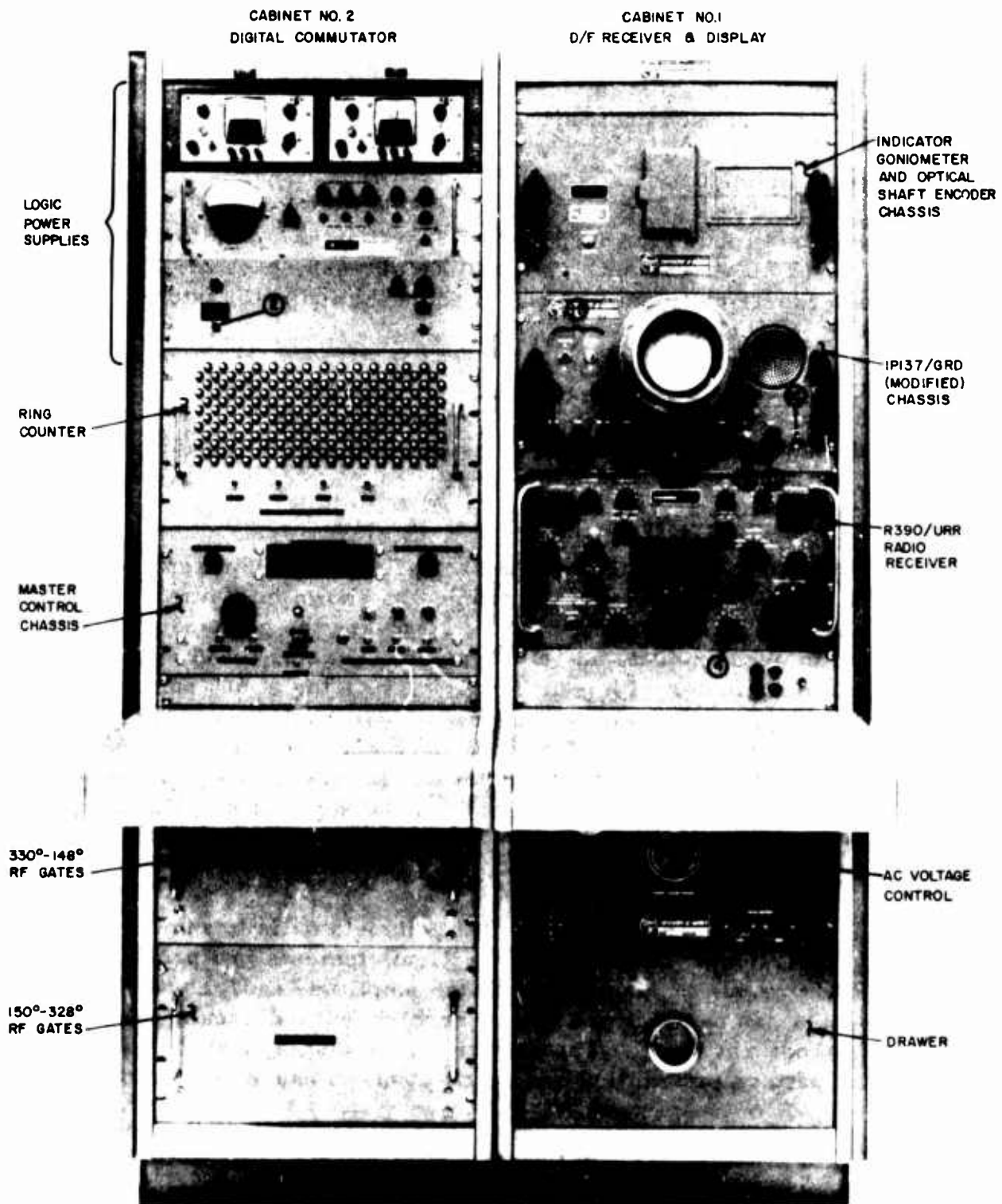

FIGURE 16. FRONT VIEW ELECTRONIC CABINETS

(5) Logic control panel and digital bearing readout indicator.

(6), (7) RF gates for antenna element switching. The back view of each cabinet is shown in Figure 17.

5.2.3 Azimuth Indicator

The azimuth indicator used in the DF system is a modified IP 137/GRD used in the AN/TRD-4A DF set. Refer to TM-11-688, page 22, for the basic information. Electrical modifications to adapt the indicator into the Beverage DF system are described in Section 9.1.

5.2.4 Radio Receiver

An R390/URR radio receiver is used; refer to TM-11-688.

5.2.5 Goniometer Chassis

The goniometer chassis contains an indicator goniometer and an optical shaft encoder with associated electronics as shown in Figure 18. The basic chassis is described in TM-11-688; however, the goniometer drive was modified to accommodate an optical pulse generator (shaft encoder) and 60-Hz synchronous motor with gear belt drive rotating at 600 rpm. The optical pulse generator is mechanically synchronized to the goniometer shaft for positive encoding operation. The optical encoder provides a pulse for each 0.1° increment of goniometer shaft rotation, i. e., 3600 per revolution, that become the "clock" or trigger pulses for the digital commutator.

5.2.6 Digital Commutator⁵

The primary function of the digital commutator is to sample the inputs from array of circularly disposed but identical elements in a programmed manner and to provide a means whereby the amplitude and/or phase of the sampled signals can be displayed in synchronism with a circular sweep applied to cathode ray tube⁶. The objective is to display a synthesized antenna field pattern (azimuth plane) based upon the assumption that all

⁵See Reference listed in Section 4.2.7-(3) for complete details and theory.

⁶Although the system was developed to operate in synchronism with the circular sweep, it is equally useful with a linear sweep system (A-scan) such as an ordinary oscilloscope in which the sweep is triggered by the sync pulse. No modification to the system is required; the diode load output of the R390/URR receiver is applied to the vertical input of the CRT, and the sync pulse from the encoder is used to trigger the scope.

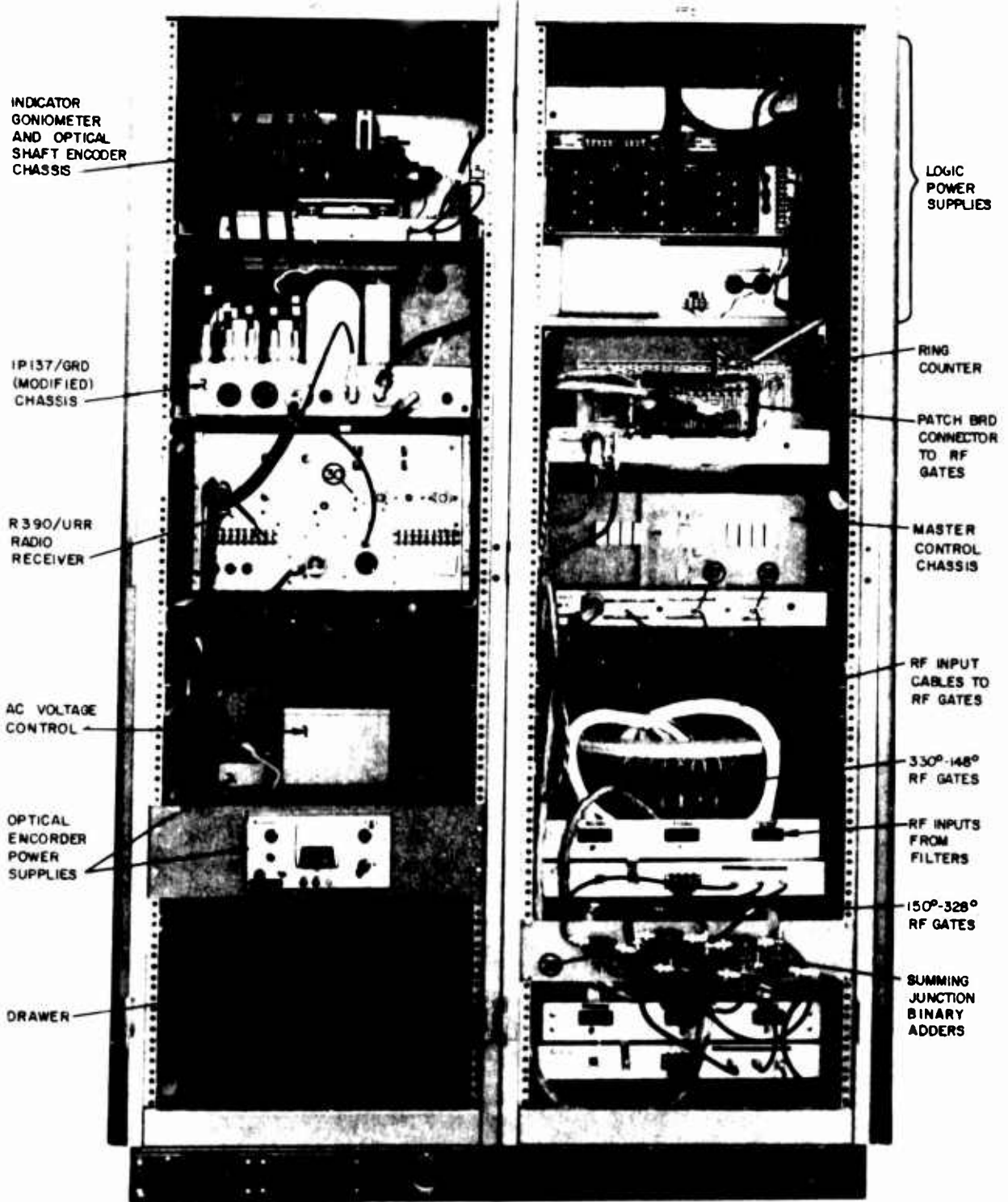

FIGURE 17. REAR VIEW ELECTRONIC CABINETS

SEE FIGURE FOR DETAIL ASSEMBLY

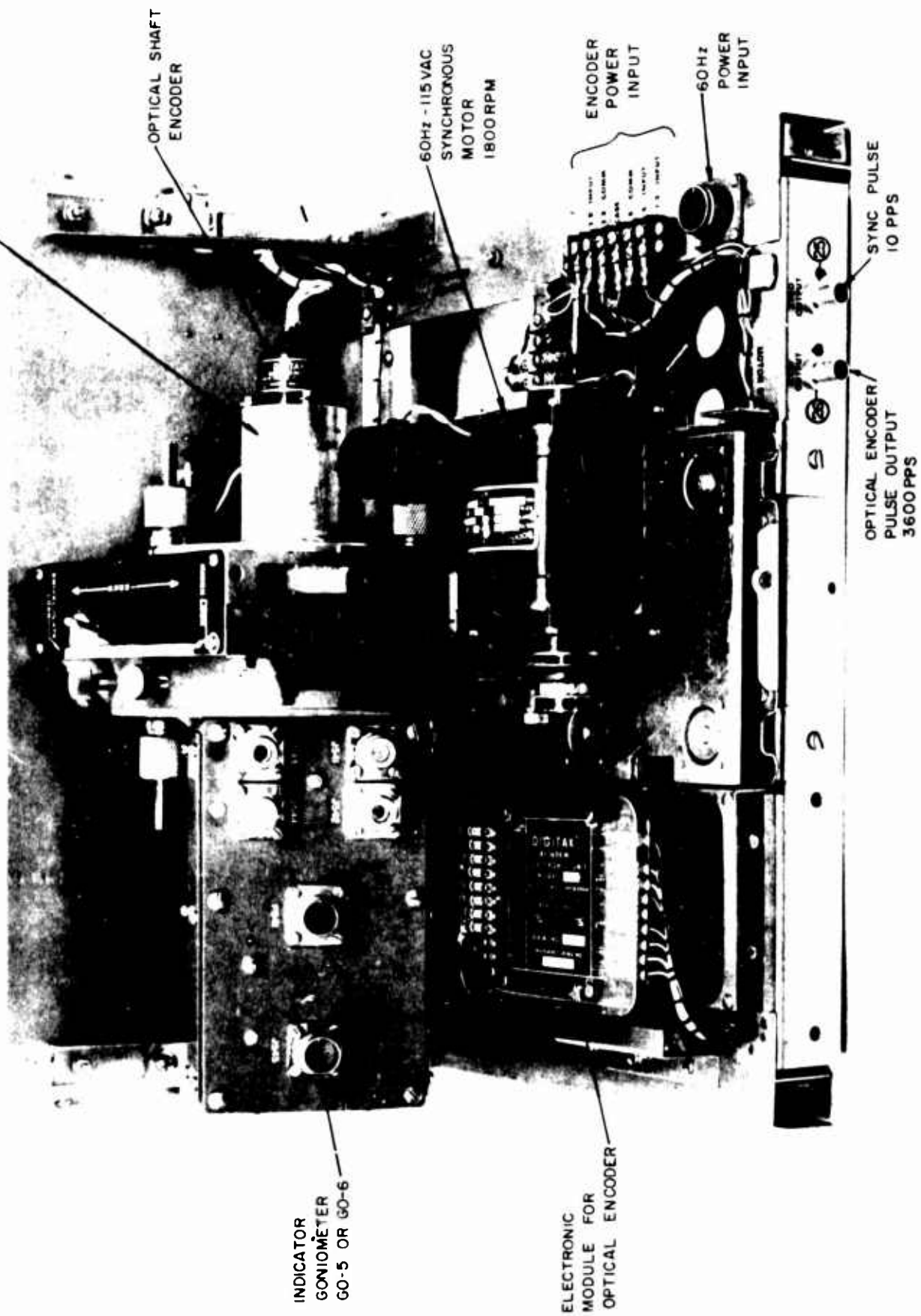

FIGURE 18. GONIOMETER AND OPTICAL SHAFT ENCODER CHASSIS

elements have identical response in both horizontal and vertical planes and are equally spaced in azimuth. The digital commutation system furnished will:

- (1) Commutate a circular array of 180 antenna elements, with an element located every 2° azimuth, by turning ON or OFF 180 RF switches one per antenna circuit in a sequential and programmed manner. It will commutate a beam formed by the summation of selected numbers of antennas (with any desired separation between sampled antenna inputs) sequentially and repetitively through 360° azimuth.
- (2) Enable the observed bearing of a received signal to be automatically read out in decimal-digit form.
- (3) Enable the rotating beam to be stopped in the boresight direction for intercept operation.

The present technique employs a transistor RF switch or gate inserted in each antenna circuit. The ON-OFF state of each gate is controlled by the logic state of a flip-flop with each antenna circuit associated with a specific shift register type flip-flop and RF gate. The flip-flops are connected as a ring counter (180-stage ring counter) to allow for continuous scan.

5.2.6.1 Ring Counter

The purpose of the ring counter is to turn the RF switch ON or OFF in a programmed manner. There is one counter stage per RF gate.

5.2.6.2 Logic Control Circuits

Logic control circuits steer the clock or trigger pulses from the optical shaft encoder to the ring counter and other counter circuits. Circuits to synchronize the clock pulses with the external signal processing and display circuits are included.

5.2.6.3 RF Gate Switch or Gate

There is one transistor switch in series with each RF input. All switch outputs are connected in parallel to the common receiver input.

5.2.7 Cables

Cables required to adapt the AN/TRD-4A set into the Beverage antenna array system and associated interconnecting cables are described in Section 6.

5.3 Shelter

A shelter is not furnished with the system; however, drawings of a suggested installation of equipment in an S-44 type shelter are furnished as part of this manual (Reference should be made to the installation guides of TM-11-688.)

6. INSTALLATION

6.1 General Installation Instructions

It is the purpose of the following instructions to provide a methodical and efficient system for the erection of the planned antenna array. Preliminary tests have shown the necessity for following a particular sequence of instructions in order to reduce the erection time and eliminate errors which would require additional time to correct. It is important to note that the overall system accuracy is dependent upon the care taken in the layout and erection of the antenna array.

6.2 Uncrating, Unpacking and Checking Equipment

The instructions outlined in TM-11-688, pages 37-38 should be followed as a general guide for unpacking procedures of this system.

All of the shipping crates for the Beverage DF system have been designed for reuse. Shipping boxes containing the antenna reels must be retained in good order for storage of the reels adjacent to the shelter during the operation; refer to Figures 19 and 20 for relative location and placement of the antenna reel boxes adjacent to the shelter. Special instructions involved with regard to unpacking the Mark II digital commutator and indicator consoles will be contained with the shipping crates. All crates have been marked to indicate which side or end should be opened such as "OPEN HERE." A complete list of all boxes and description of contents are given in Section 10.

6.3 Site Selection

6.3.1 Technical Requirements for Good Site

6.3.1.1 Area

The Beverage antenna array is a circular array with horizontal wire elements erected along a uniformly spaced series of radials from the center of the array. A full 360° circular array will require between 100 and 190 meters in radius (328 to 620 feet). It is again emphasized that it is desirable to use the largest array possible in order to obtain optimum results from the system.

A practical method to assure the suitability of a chosen site would be: (1) pace the area in two directions at right angles, and (2) drive a vehicle across the area and note the mileage from one extreme end to the other;



FIGURE 19. REPRESENTATIVE INSTALLATION AT ARRAY CENTER

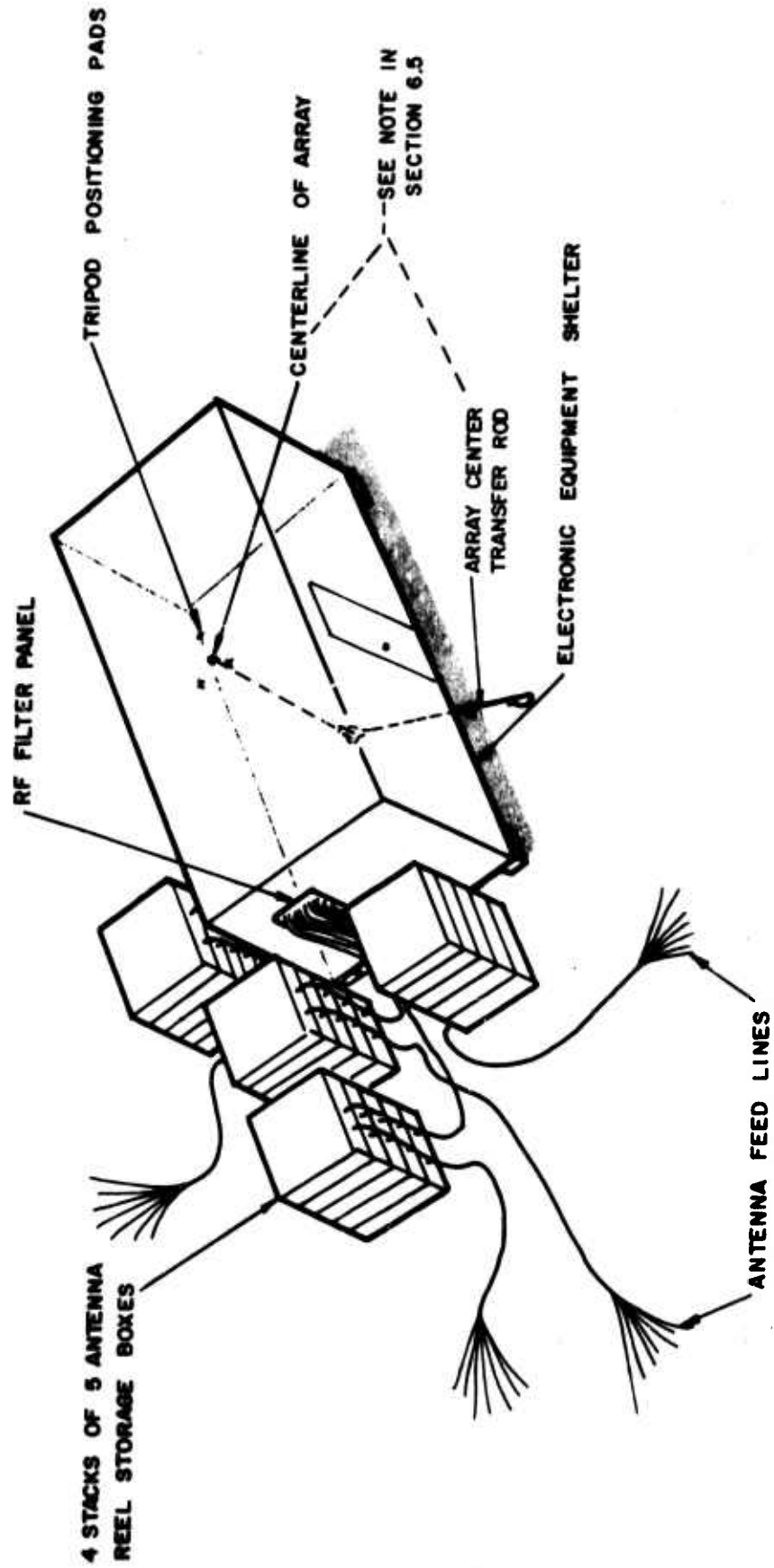

FIGURE 20. ANTENNA REEL STORAGE BOXES AND LOCATION WITH RESPECT TO SHELTER

0.25 mile will allow erection of any array of maximum diameter. After the selected site has been judged sufficient in cross section, traverse the perimeter of the proposed area to inspect and evaluate the general terrain conditions as they pertain to the erection of the array.

6.3.1.2 Obstacles

It is preferable that the area chosen for the proposed antenna site be as consistent in nature as possible and free from obstacles wherever practical. However, obstacles such as trees and rocks within the array do not have to be removed if the alignment of elements can be reasonably maintained. The array may be erected in grassy, lightly wooded or brushy areas with no special site preparation. The terrain may be sloping or slightly rolling but free of gullies. Wire fences within the array area must be removed but those outside of the array proper will have little or no effect upon the system performance.

6.3.1.3 Site Preparation

The extent of the site preparation will depend largely upon the quality of the site selected and the availability of manpower and equipment to remove surface obstructions and clear the area. An ideal condition is a freshly mowed level site with all brush and other foliage removed from the area prior to the installation. However, the more practical approach in most field installations will be the preparation of the site only as necessitated by the existing conditions in the field and the availability of equipment and personnel to clear the area. The size of the Beverage array will be determined by the dimensions of the site that has been selected.

6.4 Array Orientation and Layout

Although any single array element may be used as a reference azimuth point, it is generally preferred to use True North as the zero degree reference azimuth (Magnetic North may be used also). Instructions for determining True North are given in TM-11-688.

For installation efficiency and minimum erection time, it is recommended that the planned array be sketched on paper including size, coverage (sector, quadrant or full scale) and spacing of array elements before the installation is begun. Pages are provided in Section 11 for this purpose. An example of a layout chart is shown on the following page. It is essential that all elements be evenly spaced in the horizontal plane in order to obtain uniform antenna patterns as a function of azimuth and to minimize instrumentation errors in the DF system.

**EXAMPLE OF LAYOUT CHART FOR BEVERAGE
ANTENNA SYSTEM**

Antenna Spacing, <u>2</u> Degrees	Layout Method
Feedpoint Radius, <u>170</u> Meters	<u> </u> Transit and Chain
Termination Radius, <u>175</u> Meters	<input checked="" type="checkbox"/> Two Transits
	<u> </u> Chord Locator

Antenna Location, Degrees Azimuth	Antenna and Reel No.	Filter No.	Filter to Commutator Cable No.	Commutator Cable Group No.	RF Switch No.
0	0	0	0	1	0°
2	2	2	2	1	2°
4	4	4	4	1	4°
.
.
.
30	30	30	30	2	30°
.
.
.

See Section 11
for complete
chart

6.5 Location of Shelter and Array Center

After selecting the site and making the preliminary drawing of the layout for the array, the shelter with the electronics can be off loaded and positioned at the center of the proposed array. The shelter should be leveled with blocks or other material; the electronic equipment to be installed in the shelter may be off loaded also. Do not unload boxes containing antenna assemblies, ground rods, ground clamp and wooden stakes at this time unless absolutely necessary; see Section 6.8 (see note, p. 14).

Using the intersection of two diagonal lines drawn from opposite corners within shelter, drill a 3/4-inch hole through the floor of the shelter. Place a 3-foot ground rod (furnished) through the hole and drive into the ground below until the upper edge is even with the floor surface.

Hook the transfer rod shown in Figure 20 around the rod by reaching under the shelter. The array center point with a transfer radius from under the shelter will be used as a reference for all radial measurements during the installation of the antennas.

NOTE: It may be more convenient to lay out the array before the equipment shelter is off-loaded. The foregoing remarks and those following remain applicable except the references to the shelter should be deleted. Any measurements can be made directly from the plumb line attached to the surveyor's transit with or without the aid of the transfer rod (however, the exact radial distance must be known if the nomograph of Figure 23 is used). If this method is used, it is recommended that the shelter be positioned so that the array center is located just beyond the shelter edge containing the filter panel (Section 6.9).

6.6 Location of the 0° Antenna Element

- (1) Set up the transit and tripod on the roof of the shelter as shown in Figure 20 and level the instrument. Locate Magnetic North or True North as desired, and set the azimuth index scale on the transit to 0°. The reference scale of the transit must be properly locked to prevent shifting during the sequential measurements to be described.
- (2) The inner radius distance from the center of the shelter to the inner ground rod radius for the antenna elements must be known and laid out by surveyors chain, measuring tape, pacing or any other measuring device⁷. The exact radius is not critical but, once selected, must be measured accurately.
- (3) Place the 36-inch ground rods at the approximate points for installation around the inner radius of the antenna array. Two sledge hammers are provided to drive the ground rods to the proper depth.

An alternate method for approximate measurement of the distance from the center of the shelter to the inner ground rod radius is the use of color

⁷In clean sites, it is relatively easy to scribe a circle about the array center up to 30 or 40 meters by connecting ground rods to each end of the measuring chain and keeping the chain taut but free of the ground; walk slowly around the center while scribing a line on the ground. This should be done before the shelter is set into position.

marks (bands) on the coaxial feed cables. These marks may be located by unreeling the antenna and coaxial cable from the reels (the antenna unreels first). As the coax is unreeled, colored bands every 25 meters along the feedline will be observed. Color of band versus distance from the antenna feedpoints (including the transfer rod length) is as follows:

<u>Band Color</u> <u>(As Unreeled)</u>	<u>Approx Distance from</u> <u>Antenna Feedpoint in Meters</u> <u>(Including Transfer Rod)</u>
Orange	30
Green	55
Yellow	80
Red	105
(Reel End)	120

Use the transfer rod as a reference point, and unreel the feed cable until the desired band passes through the eye in the rod. DO NOT WHIP COAXIAL LINE TO ALIGN ALONG RADIAL.

6.7 Ground Rod Location at the Array Inner Radius

6.7.1 Method I - Location by Transit Level and Chain

Perhaps the easiest installation procedure for locating the ground rods at the array inner radius (on the feedpoint circle) is direct measurement of the radial distance by surveyors chain or similar device with radial direction determined by transit from the array center⁸.

Proceed as follows:

- (1) Hook the transfer rod around the ground rod located beneath the shelter (Section 6.5).
- (2) Attach the measurement chain to the outer end of the rod and extend to the desired distance (do not exceed 115 meters).
- (3) Pull the measuring chain taut to clear the ground or other obstructions.

⁸The procedure is not recommended for radial distances greater than 50 meters. (For radial distances greater than 50 meters, see Paragraphs 6.7.2 and 6.7.3.)

- (4) The transit operator advises the ground rod installer when he is in radial alignment with the transit indicating the 0° azimuth reference line.
- (5) Drive a ground rod into position, found in Step 2, at a 60° angle to the ground surface toward the array center and until about 10 inches remain above the surface (Figure 9).
- (6) Rotate the transit 2° (or other element spacing chosen for the antenna elements).
- (7) Move the chain until aligned along the new azimuth to the ground.
- (8) Repeat Steps (3) through (7) for the remaining elements of the antenna array.

NOTE: As the installation progresses around the circumference of the array, the alignment rod will come in contact with the corner support blocks for the shelter. At these points, unhook the rod from the center ground rod and move to the opposite side of the corner post and continue installation; the slight error introduced is not significant.

6.7.2 Method II - Two-Transit Technique

The most accurate method of locating points on the periphery of a circle is by application of half-angle formulas using two transits, one located at the array center and the other on the feedpoint circle. The technique, described pictorially in Figure 21, has the additional advantage that layout errors are not cumulative.

The transit located on the roof of the shelter (array center) will be referred to as Transit A in the instructions below. The second transit, referred to as Transit B, is located directly over the inner ground rod at 0° azimuth (located as described in Section 6.6). It should be noted that the exact radius is not important but cannot be greater than 190 meters.

It is recommended that four men be used during the layout procedure, although three is sufficient. Operator No. 1 will operate Transit A, and Operator No. 2 will operate Transit B; Operator No. 3 will move the locating rod (one of the 6-foot ground rods furnished on any convenient length pole) to the appropriate spot for placement of the ground rods, and Operator No. 4 will drive the ground rods into position.

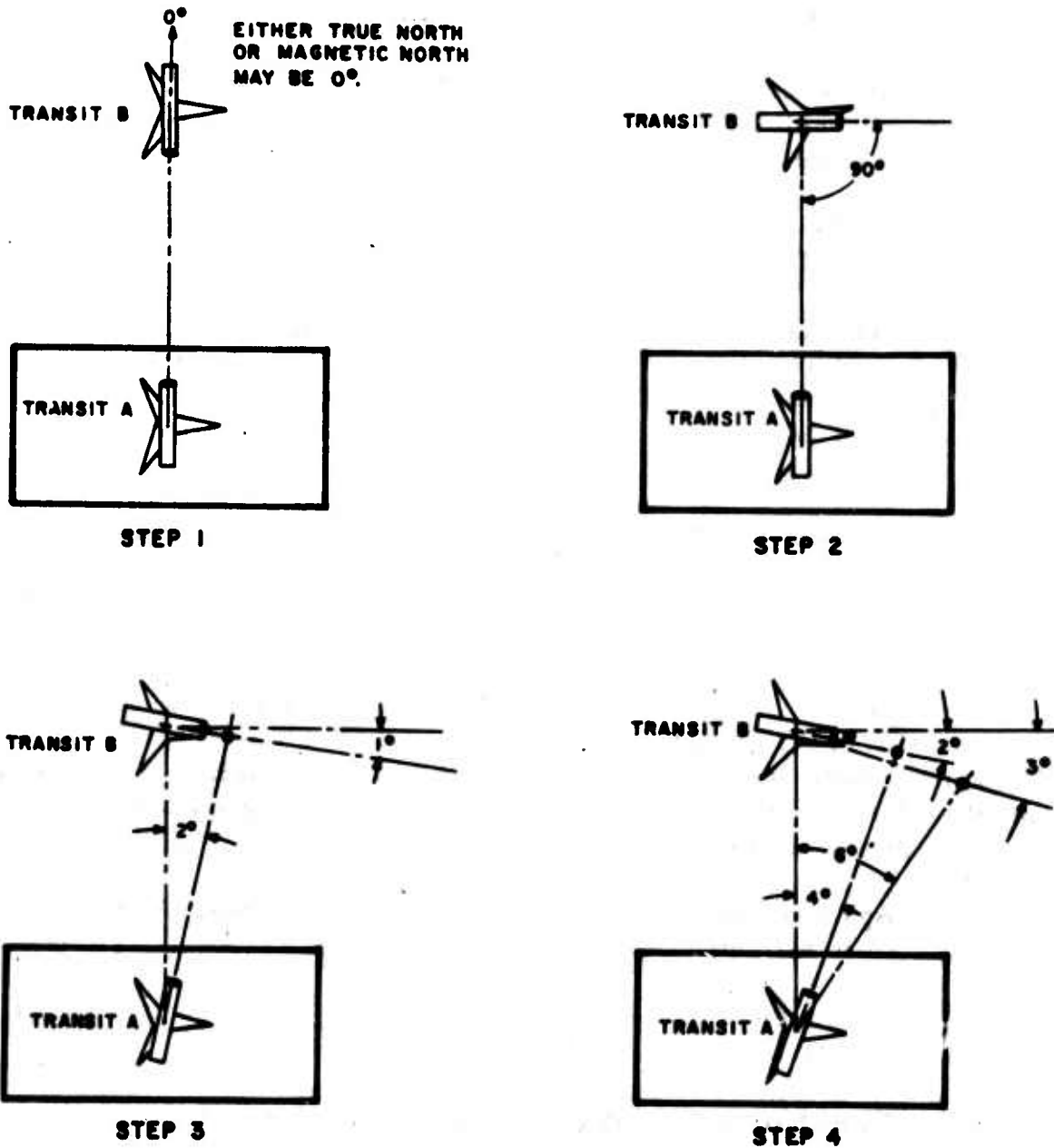

FIGURE 21. ALIGNMENT PROCEDURES FOR TWO-TRANSIT TECHNIQUE

Proceed as follows:

- (1) Set the azimuth scale of Transit A to 0° on the transit to coincide with either True North or Magnetic North as previously determined.
- (2) Set the azimuth scale of Transit B to 90° and align to Transit A along the 0° radial (Figure 21, Step 1).
- (3) Lock the reference scale of Transit B and rotate 90° counter-clockwise from the 0° radial line until the azimuth scale reads 0° (Figure 21, Step 2). Note that Operator No. 2 has turned to his left and the transit scope is sighted 90° away from the boresight of Transit A.
- (4) Rotate Transit B clockwise 1° toward Transit A, and rotate Transit A clockwise 2° (Figure 21, Step 3). This should give a reading on Transit B azimuth scale of 1° and on Transit A of 2° .

Operator No. 3 will then take the locating pole and position it at the intersection of the crosshair sighting from the two transits as confirmed by the transit operators. The point of intersection determines the 2° ground rod position for the antenna. The fourth man drives the ground rod at a 60° angle to the proper depth.

- (5) Again rotate Transit B clockwise 1° and Transit A clockwise 2° in azimuth.
- (6) Locate the 4° ground rod at the sighting intercept of Transit A (at 4°) and Transit B (at 2°).
- (7) Repeat steps (5) and (6) for each radial desired.

Note that to locate uniformly spaced points on the array circle Transit B is indexed one-half the angle of Transit A. Since errors are not cumulative, any errors in location of the ground rods on a circle are very evident when several installed ground rods are visually aligned. It is recommended that no ground rods be installed past the 90° angle for Transit A and 45° angle for Transit B.

- (8) After the 90° ground rod has been set in the clockwise direction (locating antenna positions from 2° to 90°), realign both transits along 0° radial as in Steps (1) and (2) above.

- (9) Repeat Steps (3) through (7) in counterclockwise direction until Transit A has been indexed through a 90° quadrant. Antenna positions 270° through 358° azimuth will have been located.
- (10) Move Transit B to the 90° point located in (8) above, and realign the transits as described in Steps (1) and (2) above. (Technically, the reference radial is 90° rather than 0°; however, the azimuth scales of both transits are set to 0°). A radial measurement will not be necessary if care has been used in the preceding steps.
- (11) Repeat Steps (3) through (7). Antenna positions 92° through 180° will have been located.
- (12) Move Transit B to the 270° position located as part of Steps (9) and repeat Steps (1) and (2).
- (13) Repeat Step (9) to locate antenna positions 180° to 268°.

If radial distance errors should occur at the 180° position located in Step (11), visual alignment along several ground rods can be used to smooth the inner radius.

It is possible that heat waves and terrain irregularities could introduce errors particularly for large radii and near the 90° angular points from Transit A. The possibility of error can be reduced by limiting the rotation of Transit A to, say, $\pm 60^\circ$ for any location of Transit B. This will require Transit B to be moved more often and located at each 60° radial element of the array, that is, 0°, 60°, 120°, 180°, 240°, and 300°. Correlation to previously located points will serve as convenient check points; however, it should be noted that if the radius to each new position of Transit B is measured as in Sections 6.6 or 6.7.1, Transit B need only be moved to the 120° radials of the array and Steps (1) through (8) be repeated for $\pm 60^\circ$ rotation of Transit A.

6.7.3 Method III - Location by Chord Measurement

A device has been furnished which will permit the location of ground rods on the feedpoint circle by measurement of the chord of a circle after three consecutive radii have been measured and the ground rods located. The method has the advantage that antenna positions can be rapidly located

- (1) In high grass or in the presence of other obstacles,

- (2) When it is necessary to lay out an array as quickly as possible, and
- (3) When the array radius is large.

Proper use of the locator device will permit an accurate array to be laid out by two or three men. Two men are required to move the locator device around the circle while a third sights through a transit located at the array center to check position of each ground rod. Errors can accumulate as the device is moved around the array circle radial; therefore, it is recommended that the ground rod radius be measured about every 40° or 50°.

Proceed as follows:

- (1) Locate the first three consecutive radials as described in Paragraph 6.6 or 6.7.1.
- (2) Slip the inner end of the sighting piece over the 0° ground rod and orient the connecting bar until it lies along the 0° radial as shown in Figure 22.
- (3) Place block No. 1 over the 2° (second) ground rod and block No. 2 over the 4° (third) ground rod.
- (4) Pass the wire cables connected to blocks Nos. 1 and 2 through the appropriate holes in the sighting device and pull taut (see Figure 22).
- (5) Once the cables are taut, tighten all set screws and tape excess cable to a convenient place.

Extreme care should be used in Steps (1) through (4) since the initial setup determines the dimensions of the array (chord lengths between ground rods on the circle). Once set, the device is ready for locating the remaining ground rods around the feedpoint circle.

- (6) Lift the device off the 0°, 2°, and 4° ground rods and move sighting piece (0) to the 2° ground rod.
- (7) Slide block No. 1 over the ground rod at the 4° position.
- (8) Rotate the horizontal bar of the sighting bar until the vertical rod lies on the 2° radial. (The cable to block No. 1 should be taut due to location of the 4° rod and Steps (1) through (5).

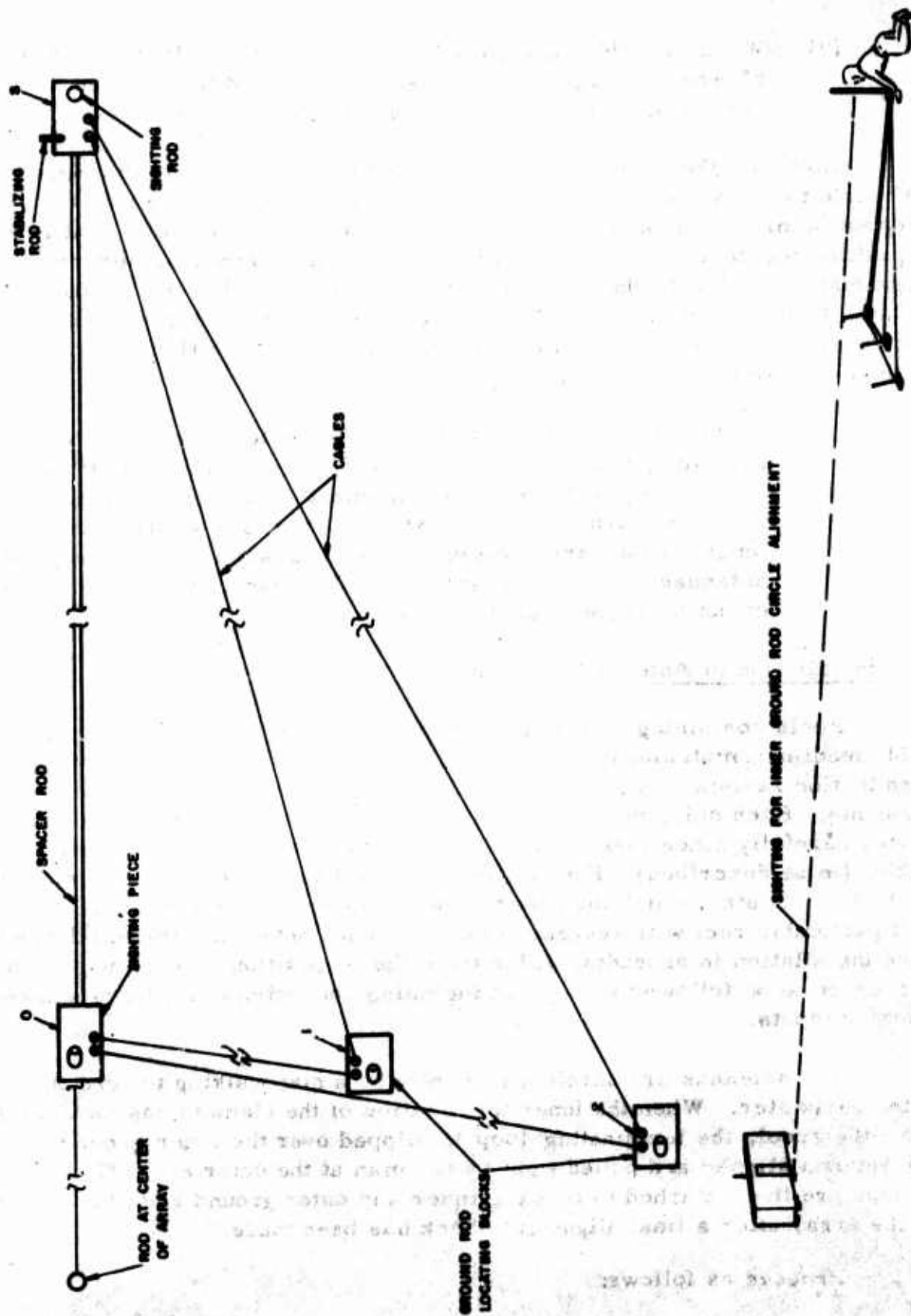

FIGURE 22. LAYOUT DEVICE FOR CHORD MEASUREMENT

- (9) When all cables are pulled taut, block No. 3 will locate the 6° ground rod position. Pass a ground rod through the hole of block No. 3 and drive to proper depth.

Note that the blocks have been drilled to permit setting the rods at the 60° angle to the ground surface. Care must be taken to insure that all cables are taut before the ground rods are driven in place. Once the 6° rod is driven, reposition the device over the 4° and 6° rods in the manner as described previously, and locate the 8° position by block No. 3. Repeat the procedure to lay out all ground rods around the inner array circle. The positions of each block to locate several of the antenna ground rod positions according to the above steps are given in Table II.

NOTE: If at any time it is not possible to place block No. 1 over the ground rod adjacent to the sighting piece or if the cables are slack, recheck alignment of the sighting piece or repeat the procedure for last located set. A chart of chord length versus array radius for several azimuthal spacings of antennas is given in Figure 23. The chart may be used for any of the three methods described.

6.8 Installation of Antenna Elements

Reels containing a complete antenna assembly including the coaxial cable feedlines, matching transformers, insulators, ground rod loops and termination resistances (see Figure 13) are furnished for an array of 180 elements. Each shipping crate contains nine antenna assemblies. Open the crates carefully since these will be used to store the reels and excess feed cables (to be described). For convenience the antenna reels are numbered 0, 2, 4, 6, 8, etc., which indicate the recommended azimuthal position of that particular reel with respect to the reference antenna. Sequential clockwise installation in ascending order from the 0° position will allow an orderly procedure to be followed throughout including connections to filters and commutator inputs.

The antennas are unrolled manually by a man walking toward the outer perimeter. When the inner termination of the element has unravelled from the spool, the terminating loop is slipped over the inner ground rod and the antenna aligned and pulled tight by the man at the outer end. Ground clamps are then attached to both the inner and outer ground rods for hookup to the array after a final alignment check has been made.

Proceed as follows:

- (1) Place the antenna reels in a sequential manner adjacent to the particular ground rod (located as described in Section 6.7) on

TABLE II. LOCATION OF CONSECUTIVE ANTENNAS
BY CHORD LOCATOR

Locator Position No.	Sighting and Ground Rod Locator Block Positions for												
	0°, 2°, 4°, 6°, 8°, 10°, 12°, 14°, 16°, 18°, 20°, . . . , 356°, 358°												
1*	0	1	2	
2	.	0	1	2	
3	.	.	0	1	2	
4	.	.	.	0	1	2	
5	0	1	2	
6	0	1	2	
7	0	1	2	.	.	.	
8	0	1	2	.	.	
9	0	1	2	.	
10	0	1	.	
11	0	.	
.	
.	
178	2	
179	1	2

- 0 - Sighting Piece
- 1 - Adjacent Antenna Position Guide
- 2 - New Antenna Position Locator
- * - 1st three positions located as in 6.6 or 6.7.1

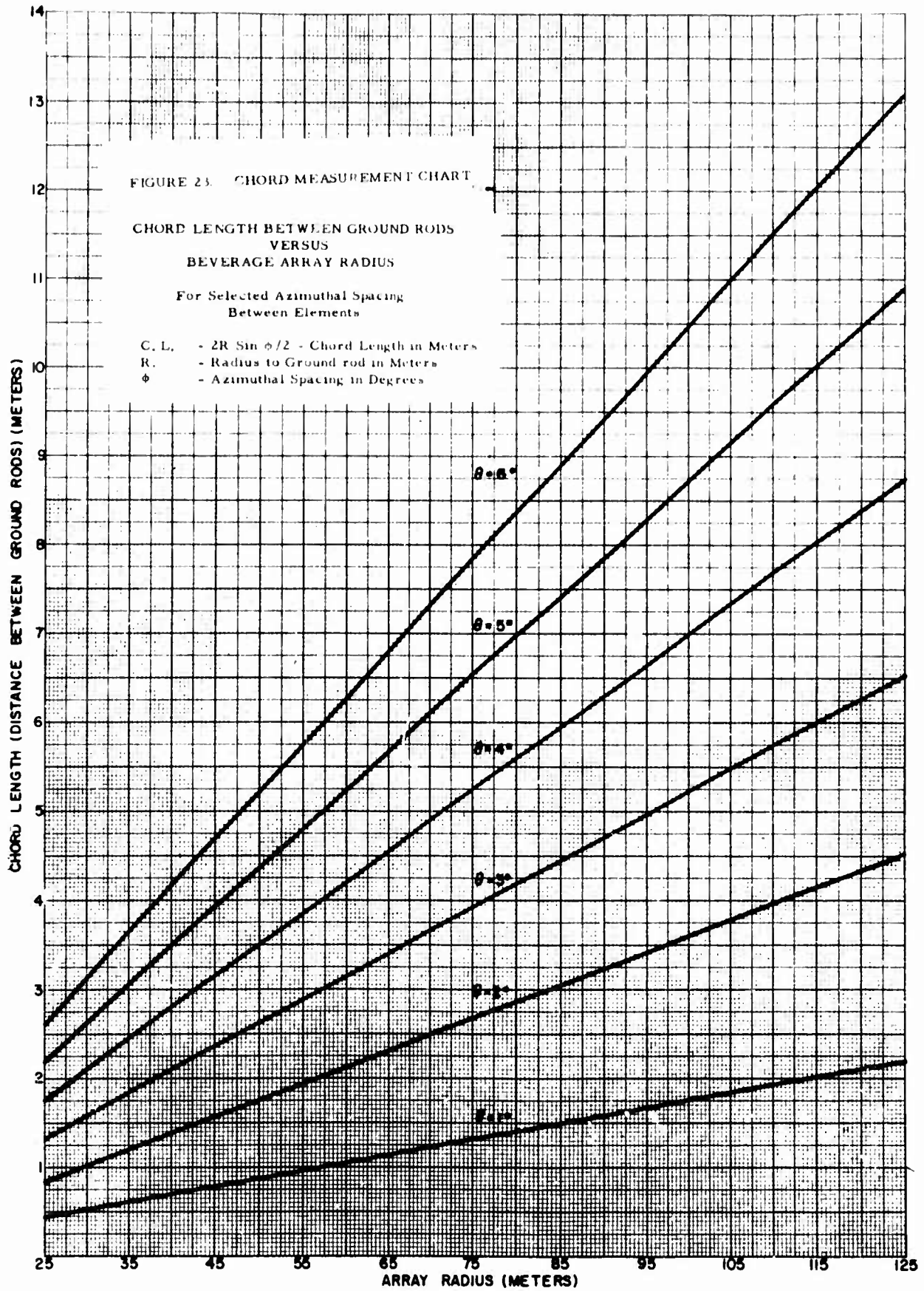

which they are to be installed. That is, antenna No. 0 at the 0° position, antenna No. 2 at the 2° position, antenna No. 4 at the 4°, etc.⁹ Care must be taken to avoid excessive damage to reels by dropping or throwing them.

- (2) Place the antenna No. 0 reel on a spare ground rod and reel holder (not furnished) to permit unwinding the antenna wire.
- (3) Remove the tape, holding the wire in place, and gently pull a copperweld antenna wire while walking along the 0° radial toward the outer periphery of the antenna array. In addition, carry four green painted wooden stakes, a ground rod and a hammer.
- (4) While pulling the antenna along the 0° radial, drop the first green stake approximately 16 paces from the inner ground rod and an additional stake approximately every 16 paces thereafter. Place the fourth stake approximately 1-1/2 paces from the outer end of the antenna.

When the antenna element has been fully extended, the matching transformer and the end of the coax cable will begin to unreel. At this point, the man standing at the inner radius should notify the man pulling the antenna element to halt.

- (5) Place the loop at the inner end of the antenna element over the inner ground rod and press the loop against the ground surface.
- (6) Install a ground clamp on the ground rod as shown in Figure 9. Attach the length of wire that extends from the loop to the ground clamp as shown¹⁰.

Note that the coaxial cable connector at the inner radius has not been connected to the transformer. DO NOT CONNECT at this time. After completion of Step (5), the man who has pulled the antenna should:

⁹It is recommended that the installation of the antenna elements begin at the 0° azimuth point; however, installation may be initiated at any point on the periphery of the antenna array as long as an orderly sequence is maintained and position chart set up.

¹⁰It is not necessary to connect the ground clamps at this time. After element installation is under way, additional men can be sent to the inner and outer perimeters with appropriate tools to fix and tighten the grounding terminations while other men set the stakes under the antennas.

- (7) Whip the antenna wire until it lies along the radial line determined by the sighting down along the wire and the inner ground rod to the center of the array shelter.
- (8) Pull the antenna until the slack is taken up (not too tight) since the wire will be raised 10 inches off the ground as described in Step (10) (see Figure 2).
- (9) Place the wire loop on the ground surface, and drive a ground rod through the loop at an angle away from the antenna (60° angle to the ground), install a ground clamp and lead wire from the loop as in Step (6). Good mechanical contact must be obtained since the wire connection to the rod furnishes the ground return for the antenna circuit¹⁰.
- (10) While returning toward the inner radius to pick up the second element, drive the green painted wooden stakes into position. Install the stakes directly below the antenna element and drive into the earth until the paint line is even with the surface of the ground (10 inches remain above the ground). Locate stakes at the drop positions of Step (4), i. e., 1 meter, 20 meters, 35 meters, and 60 meters from the outer ground rod with a fifth stake located 1 meter from the inner ground rod. All stake locations are approximate and are not critical¹⁰.
- (11) As each stake is driven, gently raise the antenna wire and place in the notch provided on the top of the stake.
- (12) Repeat Steps (10) and (11) for each stake while returning to the inner end of the antenna. The installed element should appear as described in Figures 2 and 4.
- (13) Repeat Steps (1) through (12) for the 2° element and every element in the array. Place the reels containing the coaxial feed cables near the inner radius ground rod.

CAUTION: It is necessary to sight very carefully along the antenna element to the inner ground rod and the center of the shelter each time an element is aligned before installing the outer ground rod. This will assure proper spacing between antenna elements and uniformity in the array pattern.

After the antenna elements have been installed, connect the coaxial feed cable to the BNC connector on the antenna transformer housing

(Figure 9). Place the reel over a ground rod, and, with one man on each end of the rod, walk toward the array center allowing the coaxial feed cable to unwind from the reel¹¹. Care must be taken to allow sufficient slack in the cable at the antenna connector to avoid excessive strain on the connector during the unreeling process.

In most installations, there will be excess cable left on the reel when the center of the array has been reached. Store the antenna reels and excess cable in the shipping crates for the antenna assemblies as shown in Figures 19 and 20.

Note that an extra length of coaxial cable has been wound on the outer flange of each reel as shown in Figure 13. The additional length is sufficient to run from the storage boxes to the filter panel located on the wall of the shelter (Figure 19). Excess cable on the reel proper can be used to dress the lead-in cables in convenient groups so that the access to the shelter and the equipment may be accomplished without walking over the cables.

IMPORTANT: It is recommended that the cable storage and hookup to the input filters be done in a methodical and careful manner. It will be most difficult to correct any hookup errors once the cable spools are stored. It is recommended that cables, beginning with 0° azimuth, be brought to the center and hooked up in numerical sequence in order to help eliminate the possibility of errors. Cabling is marked as to azimuth or orientation, and inputs to the filter panel are marked as to relative bearing (degrees).

6.9 Installation of High Pass Filters

A filter panel has been designed to fit into the opening obtained by removing the louver vent and mounting frame on an S-44 type shelter. The filter panel supplied as part of this system bolts into place as shown on Figure 19 (any convenient mounting location is equally acceptable, providing there is access to the filter connections). Coaxial feed cables from each antenna (via the reels in the storage box) connect to the BNC fittings on the outside of the filter panel. If the antennas were installed in numerical sequence as recommended, the antenna numbers marked on the end of the coaxial cable coincide with the markings in the filter panel. For example, attach the coaxial line marked 0 to the BNC connector marked 0 on the filter panel; attach antenna cable 2 to the filter marked 2, and so on, until all cables are terminated in the filter panel. Cable clamps are provided so that the weight of the feed cables will not be on the filter connections.

¹¹ It is possible to carry two or three reels at the same time without difficulty.

6.10 Installation of Electronic Equipment

A suggested floor plan for the shelter indicating the position of the equipment is shown in Figure 24 (see Section 6.5 for note concerning array center). Two crates marked Equipment Rack 1 and Equipment Rack 2 must be carefully opened on the side indicated and unpacked in preparation for installation in the shelter. Install each rack as shown in the figure, bolt together and/or to the floor of the shelter. Each equipment rack is shipped assembled and internally wired; install interconnecting cables as shown in Figure 25. All connectors are color coded to facilitate assembly.

6.11 Installation of Interconnecting Cables

- (1) Connect the "ZERO SYNC" (25)¹² and "OPTICAL GEN. TRIGGER" (26) from goniometer-optical shaft encoder chassis (Figure 18) Rack 1 to respective inputs (27) and (28) of the commutator control chassis (Figure 17).
- (2) Connect the commutator RF OUTPUT (29) to the R390 receiver RF INPUT (30) (Figure 17).
- (3) Connect AC power cable from cabinet 2 to J-904 of the power regulator unit of cabinet 1.

6.12 Installation of Filter Panel to Commutator Cables

Six cable groups with thirty miniature coaxial cables RG 179/U per group are supplied to connect between the antenna filter assembly and the RF gate chassis on the digital commutator (180 cables required). Multipin coaxial connectors (Burndy Corp. type RMDX 60) are furnished on one end of each cable group with the remaining end of each coaxial cable terminated in a BNC connector as shown in Figure 26. The Burndy multipin-connectors, designated cables 1 through 6, attach to corresponding numbers on the commutator input panels located in the rear of the equipment Rack 2 (Figure 27). The BNC connectors are marked 0, 2, 4, 6, etc., to correspond with the numbers on the filter panel.

IMPORTANT: The connections to the filter panel must be in the same sequential order as the radial location of the antenna elements because digital commutator requires that the antenna

¹²Item numbers on various figures will be referenced by enclosing in circles in the ensuing text. For example, item (25) will always describe the ZERO SYNC output from the goniometer chassis regardless of the figure number on which it is contained.

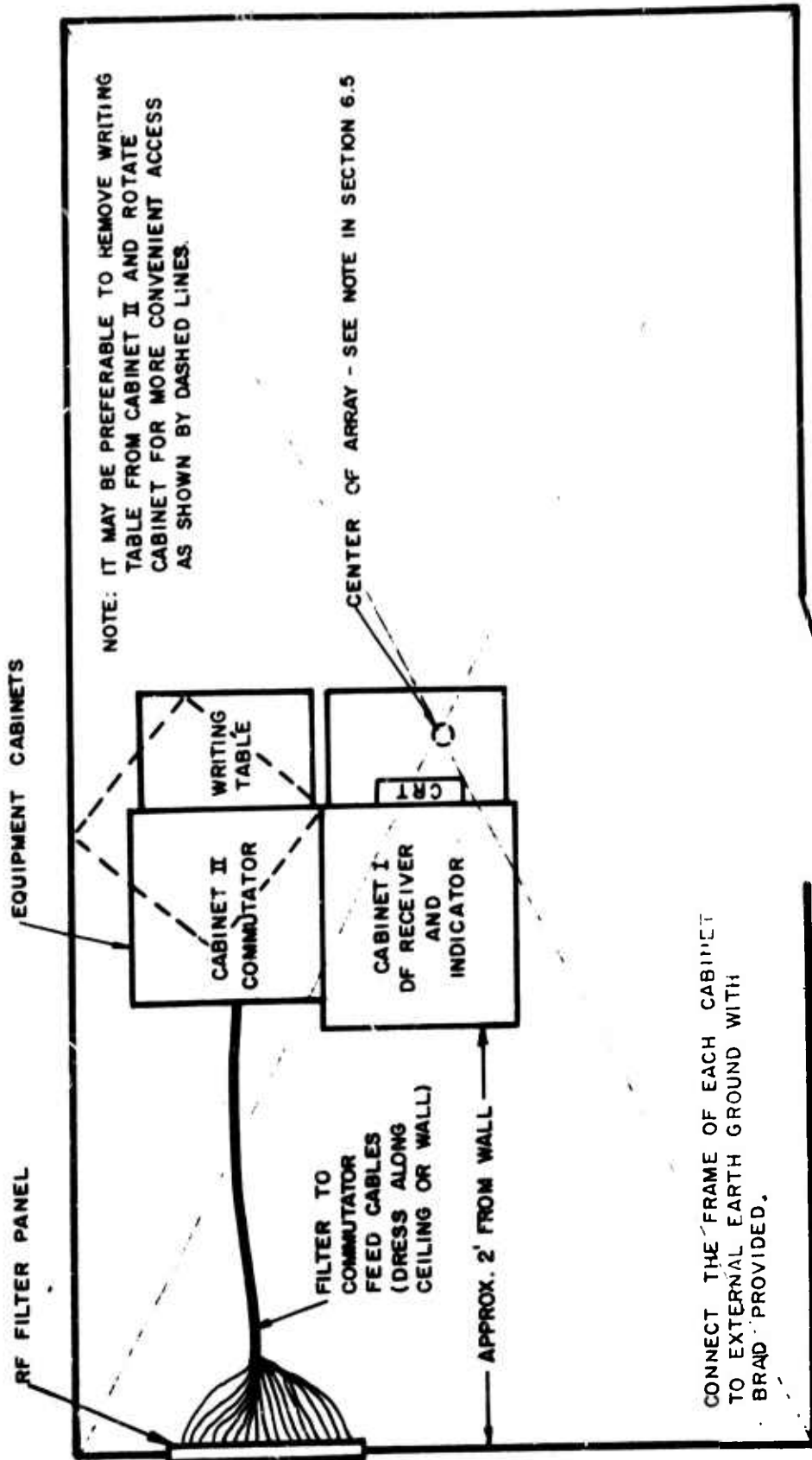

FIGURE 24. RELATIVE LOCATION OF EQUIPMENT RACKS 1 AND 2 WITHIN SHELTER

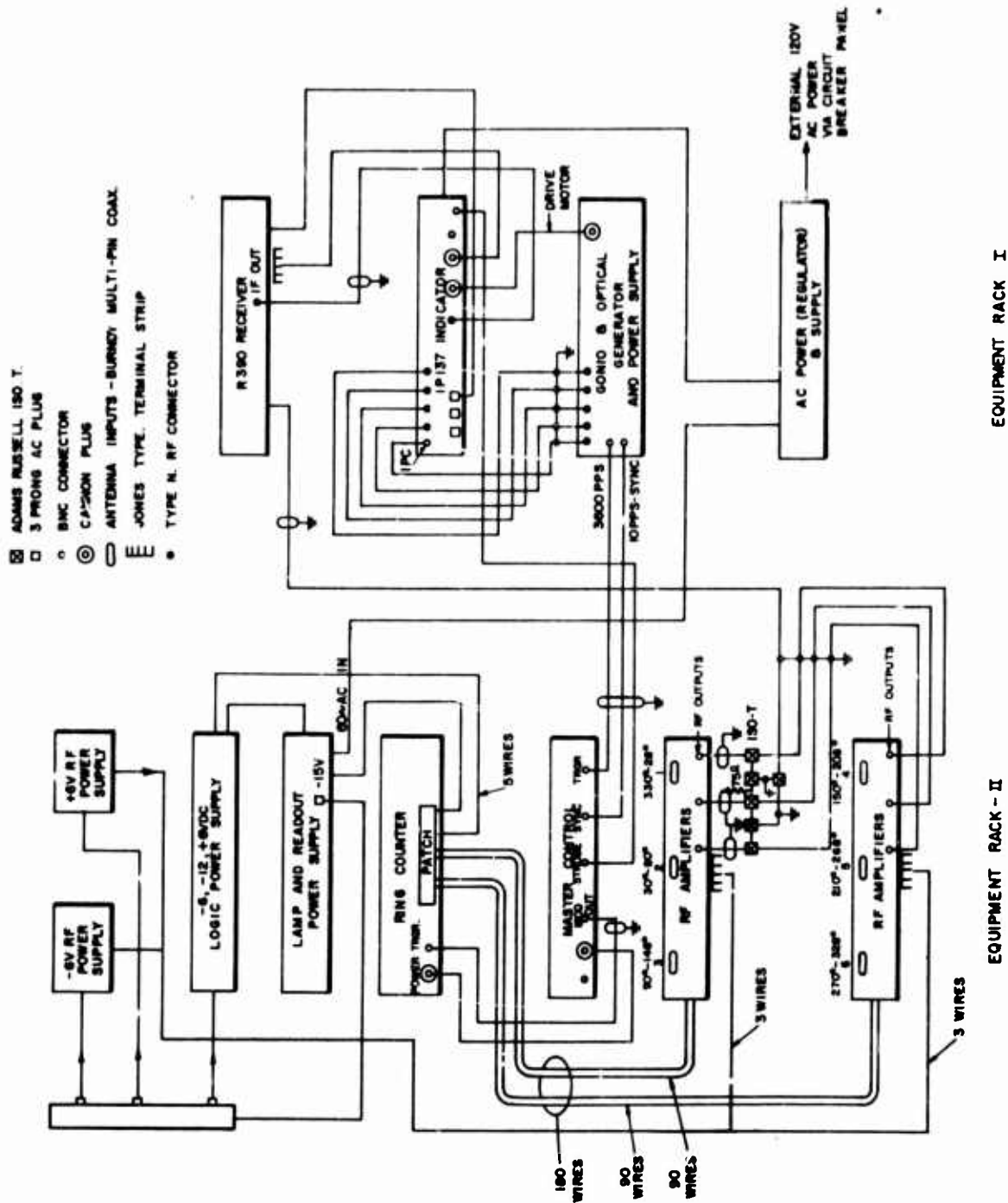

FIGURE 25. INTERCONNECTING CABLE DIAGRAM

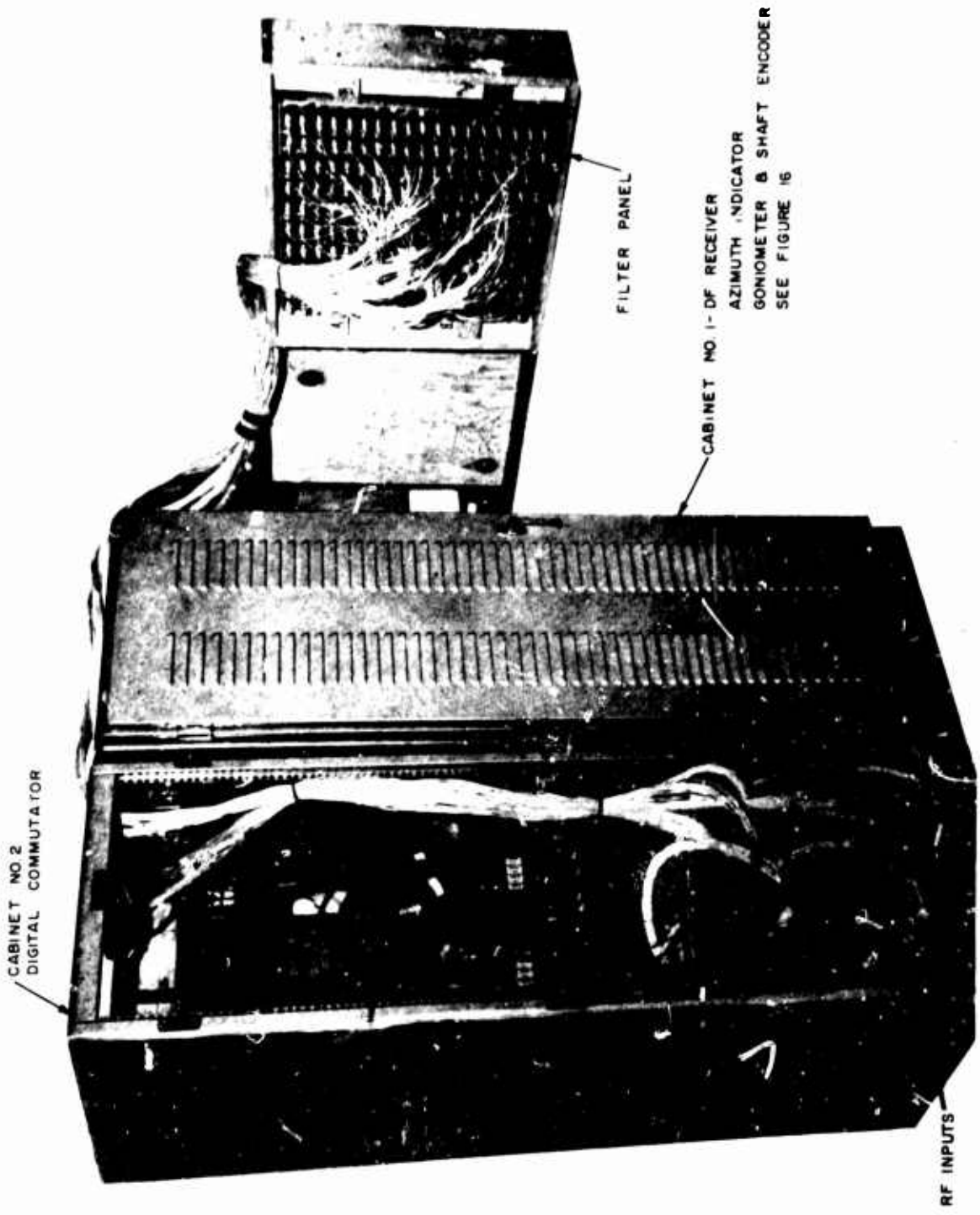

FIGURE 26. FILTER PANEL TO COMMUTATOR R. F. CABLING

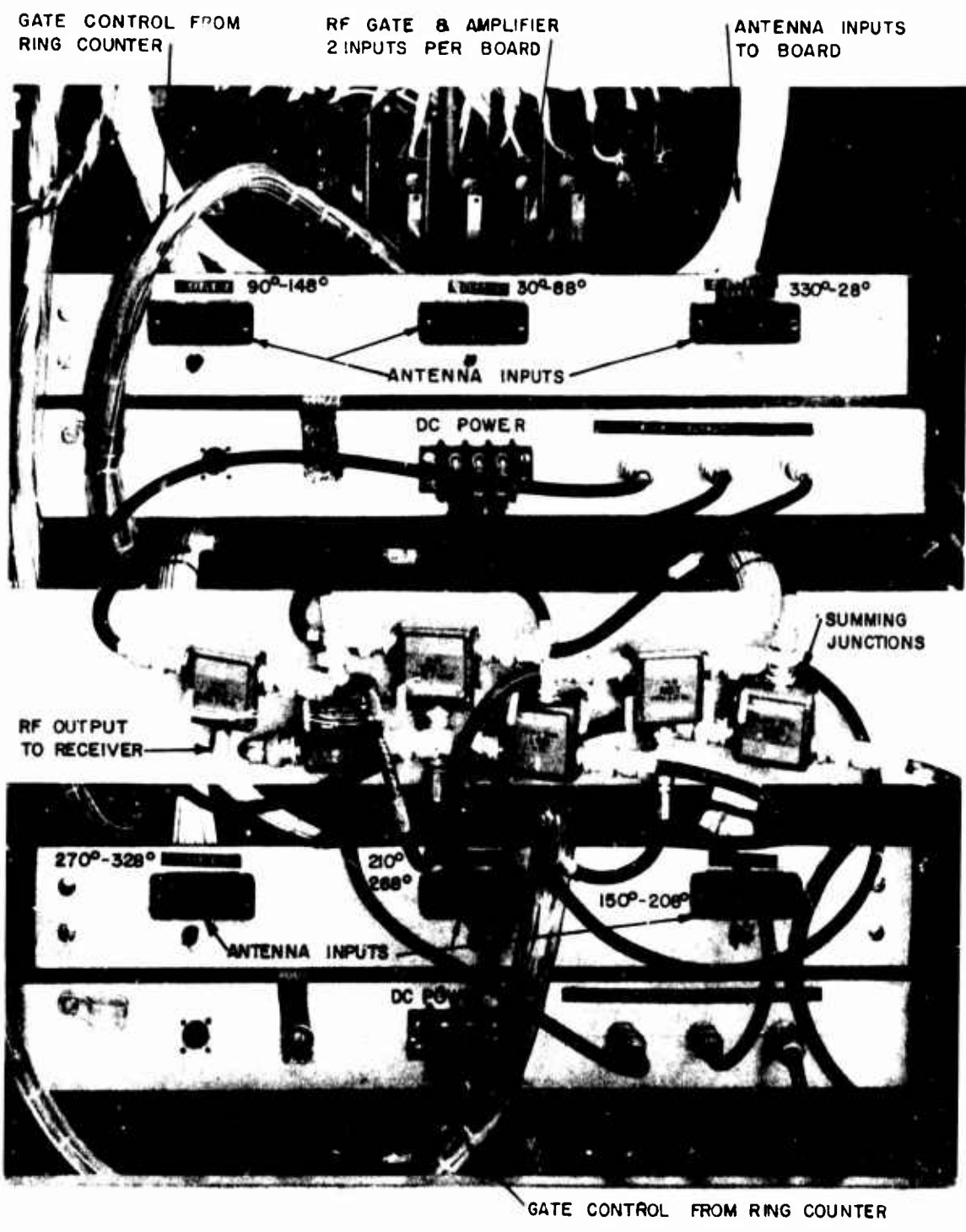

FIGURE 27. R. F. CHASSISS - REAR VIEW

inputs be connected sequentially in a clockwise manner beginning at 0 and progressing 2, 4, 6, etc. For example, input zero to the commutator connects through filter 0 to the antenna at 0°; likewise, input 2 through filter 2 to cable 2 and antenna at 2°; input 4 to 4°, etc. (there are no odd numbers in the system). All cables were properly marked prior to shipment; however, in case of difficulty, refer to the running list, Table III.

After the cables have been installed, the system is ready for final checkout prior to applying AC power. It is suggested that the equipment cabinets and the panels be reviewed for loose connections or connectors and that all connections are in the proper location. Check AC power connections. Check connections at the antenna transformer since connectors were shipped disconnected to reduce strain on the connections during installation.

6.13 Installation of 60-Hz Power

Cable and connections to an external 120VAC 60-Hz power source have not been supplied and must be provided to the shelter circuit breaker box and distribution system. See Section 4 for power requirements exclusive of heater or air conditioning units. Check power plugs and cables and connect as shown in the interconnecting diagram. Connect the power cord marked "EXTERNAL 120VAC POWER" to a convenience outlet on the shelter wall.

The breaker switch (1A) (Figure 16) on the voltage regulator chassis located at the bottom of Rack 1 will control all AC power for the two racks. In the event that it is desired to remove power from Rack 2 only, a switch for this purpose is provided on the commutator control panel (see item (2), Figure 16). Individual power supply switches should remain in the ON position at all times. The only two switches used in normal operation are (1A) and (2) described in this section.

Connect both relay racks to a convenient external earth ground near the shelter. Use one of the spare 6-foot ground rods furnished.

TABLE III. RUNNING LIST FOR FILTER-COMMUTATOR CABLES

Each cable group (there are six groups) consists of thirty individual coaxial cables (RG 179/U). The filter end of each coaxial cable is terminated with a BNC (Kings type UG38/U with RG 179/U insert) connector; the commutator ends are inserted into a multipin coaxial connector (Burndy type RMDX 60 shell). There are six Burndy connectors with thirty coaxial cables each: The Burndy designation and the corresponding filter (or antenna) number are specified below. The commutator position corresponds to the antenna number also.

<u>Burndy Designation</u>	<u>Cable 1</u>	<u>Cable 2</u>	<u>Cable 3</u>	<u>Cable 4</u>	<u>Cable 5</u>	<u>Cable 6</u>
B	330	30	90	150	210	270
F	332	32	92	152	212	272
L	334	34	94	154	214	274
R	336	36	96	156	216	276
V	338	38	98	158	218	278
Z	340	40	100	160	220	280
DD	342	42	102	162	222	282
JJ	344	44	104	164	224	284
D	346	46	106	166	226	286
J	348	48	108	168	228	288
N	350	50	110	170	230	290
T	352	52	112	172	232	292
X	354	54	114	174	234	294
BB	356	56	116	176	236	296
FF	358	58	118	178	238	298
A	0	60	120	180	240	300
E	2	62	122	182	242	302
K	4	64	124	184	244	304
P	6	66	126	186	246	306
V	8	68	128	188	248	308
Y	10	70	130	190	250	310
CC	12	72	132	192	252	312
HH	14	74	134	194	254	314
C	16	76	136	196	256	316
H	18	78	138	198	258	318
M	20	80	140	200	260	320
S	22	82	142	202	262	322
W	24	84	144	204	264	324
AA	26	86	146	206	266	326
EE	28	88	148	208	268	328

7. OPERATING INSTRUCTIONS

7.1 Power

- (1) Insure that all individual power supply switches are in the ON position. These should remain ON at all times.
- (2) Turn MAIN POWER, GONIO DRIVE (1B) and INDICATOR (1C) power switches ON.
- (3) Turn LINE INPUT power switch (1A) Figure 16 to 115V ON. Check voltage reading of regulator supply and adjust between 115 and 120VAC.
- (4) Turn COMMUTATOR MASTER SWITCH AC POWER (2) - ON.
- (5) Check DC voltage as marked on each power supply in Rack 2. The actual operating voltages are measured on the load sides of the protection diodes on P. C. Board 9 (Figure 52).

NOTE: In normal operation, all AC power should be controlled by the master power switch LINE INPUT POWER (1A) ; however, power to Rack 2 may be turned off if required by the COMMUTATOR MASTER SWITCH AC POWER (2). See Section 9.4 for location of fuses and fuse size.

7.2 Circle Adjust of IP 137/GRD - Refer to Figure 16

- (1) Reduce R390 receiver function switch (3) to STANDBY and RF GAIN control (4) to minimum.
- (2) Adjust INTENSITY (5) and FOCUS (6) on IP 137.
- (3) Adjust HORIZONTAL (7) and VERTICAL (8) controls to center display.
- (4) Minimize circle (spot) size using both gain (9) and phase (10) controls. Correct size is a dot at the center of the CRT. These controls are interacting and may need occasional adjustment if drift occurs in the control modulator circuits.

- (5) Check operation of deflection circuits and indicator goniometer by switching SIZE switch (11) to the TEST position. A full-size circle should be obtained on the CRT. If not, correct adjust gain controls on V303 and V303/M (see Section 9.1). Return SIZE switch to operate position.
- (6) Repeat Step (4).

7.3 Methods of Azimuthal Bearing Determination

These options of bearing determination are available:

- (1) Mechanical alidade, part of the CRT assembly for the IP 137/GRD indicator - azimuth angle is read from an engraved ring around the CRT.
- (2) Strobe slew with electronic alidade and automatic digital readout of bearing.
- (3) Pattern slew with electronic alidade and automatic digital readout of bearing.

The desired method is selected by front panel switch DIGITAL BEARING READOUT METHOD (12). The switch is used to specifically select either Method (2) or (3) above; however, Method (1) may be used with the switch in either position as long as the SLEW DIRECTION (22), (23) controls are not operated.

The automatic digital bearing readout reduces one source of operator error by permitting the operator to make a bearing cut without interpreting or interpolating the azimuth scale on the CRT; that is, when the operator properly adjusts the electronic alidade to overlay the display pattern, the azimuth bearing is available directly on the digital readout (24) to a 0.1° resolution. Furthermore, the possibility of errors due to parallax are eliminated by the superposition of the strobe marker signal on the video signal.

7.3.1 Mechanical Alidade

See TM-11-688 for instructions of bearing readout.

7.3.2 Strobe Slew or Strobe Rotation Option

Strobe slew option will allow the operator to rotate the electronic strobe (brightened portion of CRT trace) to symmetrically coincide with the

displayed pattern. The strobe position in degrees azimuth is displayed with 0.1° resolution on the digital bearing readout on the commutator front panel BEARING INDICATOR (24) (Figure 28). The alidade reading of 7.3.1 will provide the same bearing; however, the automatic bearing readout has increased resolution.

7.3.3 Pattern Slew or Pattern Rotation Option

Since there is some evidence that operator errors in bearing determination are reduced if the operator can always view the pattern at the same display angle on the CRT, a further option is provided to allow the operator to rotate the pattern until the pattern axis becomes vertical, i.e., coincident with the 0° mark on the CRT alidade. In addition, the electronic strobe is fixed and coincident with the 0° marker (although not a prerequisite). When the pattern is properly rotated, the digital bearing readout will indicate the original azimuthal direction of the beam.

7.4 Operation of Commutator - Refer to Figures 28 and 29

- (1) Select bearing determination method strobe slew or pattern slew by DIGITAL BEARING READOUT METHOD (DBRM) function switch (12).
- (2) Set the clock input switch (13) to the OPERATE position.
- (3) Press the STOP button (14). Lamps above STOP and RESET switches should be on. Lamp above START should be out.
- (4) Press the RESET button (15). Lamp above RESET and START should be out. Lamp above STOP should be on; all indicator lamps on RING COUNTER (16) should be out.
- (5) Write in the desired number of antennas to be commutated. (See Section 7.5) about boresight reference of 0° (17). Indicators that are symmetrical about the 0° lamp should be on.
- (6) Press the START button (19). Lamp above START should be on, and lamps above STOP and RESET should be out. COMMUTATOR RUN indicator (20) will flash continuously at an 10-Hz rate.

NOTE: The STOP-RESET-START switches are connected in a latching arrangement, and the sequence must be followed in that order; therefore, if the RESET button is

NUMBER UNDER EACH SWITCH -
LAMP INDICATES ASSOCIATED
ANTENNA POSITION

RING COUNTER CHASSIS
& BEAMFORMER PANEL

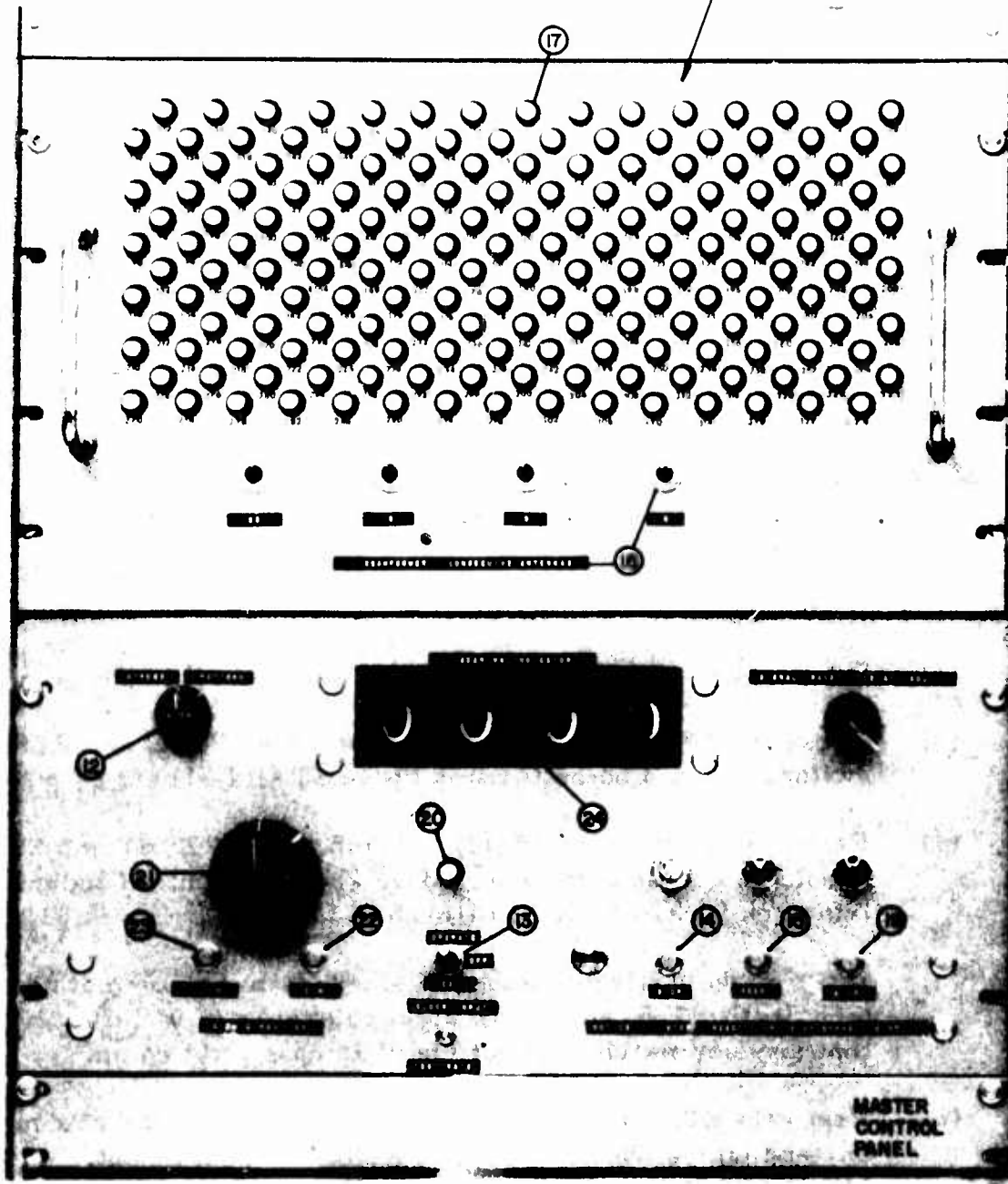

FIGURE 28. RING COUNTER AND MASTER CONTROL CHASSIS

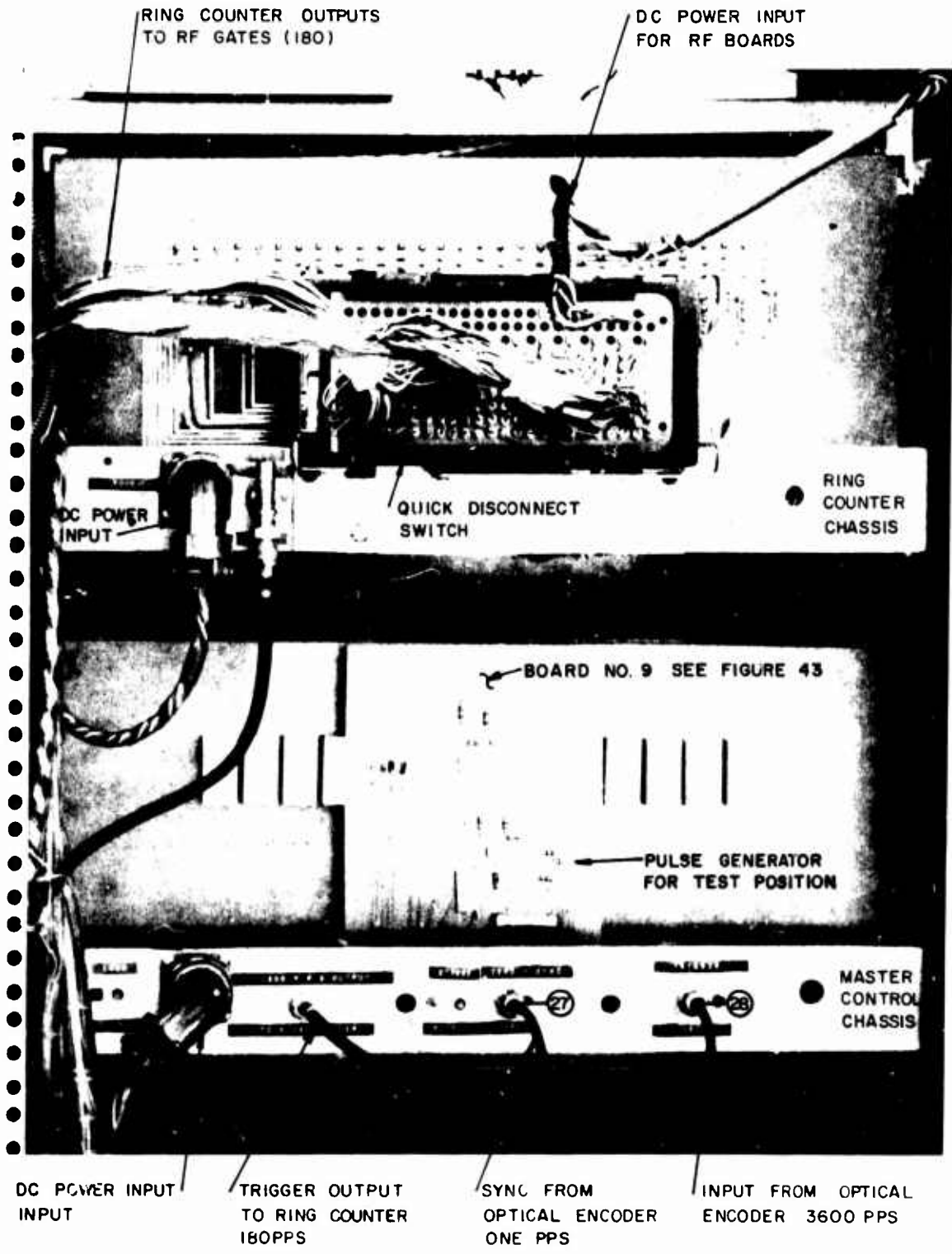

FIGURE 29. RING COUNTER AND MASTER CONTROL CHASSIS - REAR VIEW

pushed before STOP, then the sequence must be RESET-START-STOP-RESET.

- (7) Adjust the GAIN and FREQUENCY of the R390 receiver to display an antenna pattern on the IP 137 indicator (either "on-the-air signal or test signal described in Section 8).
- (8) Bearing readout options are as follows:
 - (a) Mechanical Alidade on CRT. Go to Step (11).
 - (b) Digital Bearing - readout with electronic strobe or cursor.
- (9) Rotate the strobe or pattern [depending on the option selected in Step (1)] by pressing the clockwise CW (22) or counterclockwise CCW (23) SLEW DIRECTION control buttons. The rotation and speed is adjusted by the multiturn dial SLEW RATE (21) located between the CW and CCW buttons. When the strobe or pattern is properly aligned, read the bearing from the BEARING INDICATOR (24) on the front panel.

CAUTION: Correct bearing readout is possible only when certain criteria are met. See Section 7.3. Furthermore, if the BEARING SELECT switch (12) position is changed, the STOP (14) and RESET (15) buttons [Steps (3) and (4), Section 7.4] must be pressed in that order to properly preset the logic networks for correct bearing readout. Continue with Step (5).

- (10) To switch from DF scanning mode to INTERCEPT mode, push STOP button (14). Boresight of the rotating beam set up in Step (5) will stop on the azimuthal bearing indicated on the digital readout (24) if cursor is properly set.
- (11) If mechanical alidade is used, read azimuth as described in TM-11-688.

It is recommended that the operator experiment with the bearing determination controls to become familiar with the possibilities of each method. See Figure 30A for typical CRT patterns of pattern rotation.

7.5 Initial System Checkout, Test and Calibration

See Sections 8 and 9.



(a) IP 137 display of four RF inputs excited by signal generator at 0° , 90° , 180° and 270° . Sequential scan of one input around the array. Display shows 1° nonlinearity at 90° . When calibrating, use only one input excited and repeat for every 2° input.



(b) Multiple exposure of IP 137 display to show example of pattern rotation from a true bearing of 266° to alignment with the 0° mark. The digital bearing readout automatically follows the pattern. However, the correct bearing is obtained only when pattern is aligned with 0° line.

FIGURE 30A. EXAMPLES OF DISPLAY CALIBRATION AND PATTERN ROTATION

7.6 Formation of the Antenna Beam

The design of the digital commutator will permit the DF operator to select the optimum antenna beam for either DF mode (or intercept mode) of operation. Although an almost limitless number of antenna summation configurations can be conceived and set into the commutator, experience has shown that the most used beams are formed from the summation of signals from consecutive antennas in the array. The optimum number used is dependent upon parameters such as frequency, site, antenna length, array size and element height. For the array furnished, the number will vary between twenty-three consecutive antennas (at 2° spacing) for 2 to 5 MHz, to nine consecutive antennas for 18 to 30 MHz. A few simple tests by the operator using the DF mode on strong signals at various frequencies will quickly show the optimum arrangement for the parameters specified.

The beam forming switches are located on the RING COUNTER chassis (16) (Figure 28). Each of the indicators on the front panel is a combination indicator and momentary action SPST switch that is associated with a particular antenna circuit; the specified azimuth for a 2° system is indicated immediately under each lamp. If, after the STOP (14) and RESET (15) switches are depressed, the lamp projection (for example, the 0° lamp (17)) is pushed in, the indicator will come ON; when a lamp is ON, it indicates that the associated antenna circuit is being sampled by the receiver. A few trials will show that any of the 180 antennas may be set in the ON position by the above method or turned OFF by operation of the RESET switch.

It is recommended that consecutive antennas be used initially until the operators obtain experience in commutator operation.

7.6.1 DF Mode Operation

Prior to operating in the DF mode, the desired beam must be set into the ring counter while in the static (nonrunning condition). The most used antenna beams can be set in automatically by the beamformer switches (18) for five, nine, fifteen or twenty-three consecutive antennas. Select a desired number of elements (fifteen will give good results over most of the HF band for the array furnished), and push the BEAMFORMER button for that number. Note that the same number of indicators will be ON on the RING COUNTER and that they are symmetrically located about 0°. For example, for five consecutive antennas, the lamps for 356°, 358°, 0°, 2°, and 4° will be ON, and, for nine antennas, lamps for 352°, 354°, 356°, 358°, 0°, 2°, 4°, 6° and 8° will be ON. The beam to be rotated clockwise around the array will always consist of the number and relative locations of antennas selected in the static position.

Note also that the 0° antenna is always the boresight of reference position for all static beams. Since the rotating beam must be synchronized to the rotating spot on the CRT display, it is necessary to establish a reference direction from which to synchronize the beam and display. For the system described, the reference position is True North (0°). Synchronized operation is automatic if the static beam is set in symmetrically about 0°. Proceed to Step (6) of Section 7.4.

Typical CRT patterns for various frequencies and distance are shown in Figures 30B through 30E.

7.6.2 Intercept Mode Operation

Intercept operation via the commutator may be set up manually or automatically switched from the DF mode. Automatic switch from DF to intercept mode is accomplished as follows:

- (1) Adjust the electronic alidade (Strobe) for the correct observed bearing (either pattern or strobe slew function).
- (2) Push the STOP button (14) on the commutator. The antenna beam will automatically stop with boresight in the azimuthal direction indicated on the digital bearing readout.

NOTE: Automatic switching from DF to INTERCEPT mode can be used only in conjunction with the automatic bearing readout function. If the mechanical bearing marker on the CRT force is used for bearing readout as described in Paragraph 7.3.1, the beam boresight will stop only at 0.0° (the digital indication).

Intercept operation in manual mode is accomplished as follows:

- (1) Push STOP (14) and RESET (15) buttons on the Master Control Unit.
- (2) Manually set the desired beam into the beamformer by depressing the switch-lamps on the ring counter for the azimuth desired. It is recommended that the same number of antennas be used in the intercept modes as in the DF mode.



Frequency - 5.000 MHz
 Array size - 23 consecutive
 antennas



Frequency - 10.000 MHz
 Array size - 17 consecutive
 antennas



Frequency - 15.000 MHz
 Array size - 17 consecutive
 antennas



Frequency - 20.000 MHz
 Array size - 11 consecutive
 antennas

Constants: 75 meters long,
 less than 0.25 meter above
 ground and radially spaced
 every 2°.

46

131

Feedpoint radius meters

FIGURE 30B. BEVERAGE ARRAY PATTERN FOR WWV



Call - WWV
 Location - Ft. Collins, Colo.
 Distance - 857 miles
 Frequency - 2.500 MHz
 Array size - 23 consecutive
 antennas



Call - WNU
 Location - New Orleans, La.
 Distance - 534 miles
 Frequency - 2.048 MHz
 Array size - 23 consecutive
 antennas



Call - AFB5E1B
 Location - Houston, Texas
 Distance - 193 miles
 Frequency - 3.311 MHz
 Array size - 23 consecutive
 antennas



Call - WKA 24
 Location - New Orleans, La.
 Distance - 534
 Frequency - 4.985 MHz
 Array size - 23 consecutive
 antennas
 (Rapid Fading)

Constants: 75 meters long,
 less than 0.25 meter above
 ground and radially spaced
 every 2°

46 131
 Feedpoint radius meters

FIGURE 30C. BEVERAGE ARRAY PATTERNS

8. SYSTEM CHECKOUT PROCEDURE

Once all antenna assemblies have been installed and connected to the signal processing equipment, check the operation of each individual antenna network. The procedure to be described will detect defective antennas, antenna transformers, coaxial feedlines or high pass filters. Additional test, adjustments, troubleshooting and maintenance details are provided in Section 9.

Two men are required, one to position an RF source, and another to observe the pattern on the CRT indicator. A portable, low power, battery operated RF source operating at 4.070 MHz is furnished with the signal processing equipment; however, any suitable HF signal generator such as the AN/URM-25D or Transmitter T-279/UR may be used.

8.1 Array Alignment and Circuit Check

The purpose of the following tests is to insure that the antenna array is properly connected in the correct sequence to the digital commutator and to check each antenna to commutator circuit for continuity and gain.

- (1) Turn system ON and make preliminary adjustments (Sections 7.1 to 7.3).
- (2) Follow Steps (1) through (4) of operating instructions for commutator, Operation Section 7.4.
- (3) Push the 0° antenna switch (17) on the commutator control board to set 0° RF switch ON. Push START button (19).
- (4) Connect RF source across the antenna side of the transformer for the 0° antenna (antenna connected).

NOTE: A special BNC test jack is provided for the 0° input (0° antenna test input) on the FRONT of the upper RF Drawer to perform initial tests and assist in troubleshooting.

- (5) Set receiver to the frequency of the RF source and advance receiver RF gain until the tip of the CRT pattern lies about 1/4 inch from the alidade marker on the periphery of the indicator. See Figure 30A for typical shape.

Rotate the mechanical cursor so that an engraved line overlays the tip of the pattern. The cursor should coincide with 0°. If the line is not on 0°, the indicator goniometer, optical encoder, or signal transit delay adjust must be repositioned or reset until the pattern tip is at 0°. The SIGNAL TRANSIT DELAY will permit vernier adjustment in 0.1° steps for ±0.5°. For each adjustment, repeat Steps (2) through (5). (The goniometer or encoder may be rotated by loosening the locking or hold down screws. Refer to TM-11-688.)

- (6) Disconnect the RF source from the 0° antenna and reconnect to the 2° antenna. An identical pattern as described above will appear on the indicator. The pattern display should be coincident with the alidade line set to 2° with no change in length. Pattern amplitude variations of about 1/4 inch can be tolerated. However, if the pattern is shortened over 1/4 inch, some component of the antenna circuit is not operating correctly (see Section 8.2).
- (7) Disconnect the RF source from the 2° antenna and reconnect to the 4° antenna. The display should be coincident with the 4° mark.
- (8) Repeat for all antennas in the array.

NOTE: If the displayed pattern is not coincident with the same azimuth marker as the alidade or the antenna position tested, recheck cables and connections for proper installation.

8.2 Test Procedure for Incorrect or Inoperative Circuit

The following procedure assumes that the commutator and DF display equipment is operating correctly; refer to Section 9 for other details if a display is not obtained or commutator does not run. A considerably shortened pattern length is an indication of a defective antenna assembly. To find the defective component, the following procedure should be followed¹³:

- (1) Check the antenna tautness. If loose, check for a broken insulator at each end.
- (2) Bypass the antenna transformer and connect the RF Source directly to the coaxial feedline. If a normal pattern results,

¹³In the order shown 1 through 7 or in reverse order f through a.

the transformer is evidently defective. Check connections and continuity (see Figure 14 for circuit schematic). Replace transformer if necessary.

- (3) If a reduced pattern length is still encountered, disconnect the feedline at the low pass filter and connect the RF source to the filter. If a normal pattern results, the coaxial feedline is defective. Check for faulty connectors and/or replace cable.
- (4) If the pattern is still shortened, bypass the filter and connect the RF source directly to the filter to commutator cable. A normal pattern at this point is an indication of a defective filter. Check connections and/or replace filter.
- (5) A still abnormal pattern is an indication of either a defective filter cable or RF board. Bypass the feedline and connect to the proper RF input (Burndy connector) on the commutator via special test cable furnished and again observe the pattern. A normal pattern indicates a defective filter cable; check connectors particularly the Burndy connector for damaged center pin. A shortened pattern indicates a defective RF board.
- (6) Check for improper setting of gain controls on the proper RF circuit (see Figure 15) or replace board and set gain as described in Section 9. The defective component should be removed and replaced.
- (7) After the defective component has been located, repaired or replaced, recheck the antenna circuit for normal pattern indication.
- (8) A pattern with excessive amplitude may be caused by a faulty connection or by improper gain setting on the RF board; however, since all gain adjustments have been correctly set prior to shipment, it is recommended that all circuit connections be checked prior to adjustment of the RF gain.

8.3 System Calibration^{14, 15}

In order to minimize instrumentation errors, it will be necessary to calibrate the CRT display as a function of azimuth and bearing readout

¹⁴Calibration may be performed simultaneously with the array checkout tests of Section 8.1.

¹⁵In practice, system calibration is unnecessary if care has been taken in the array installation. However, tactical situations may require rapid array installations, and calibration is recommended.

method. Use the graph paper furnished in Section 11 to plot error specified antenna position minus bearing as read from the alidade versus the observed bearing.

Error = Antenna Position - Alidade or Decimal Readout Indications

$$E = AP - OB$$

To correct the observed bearings for on-the-air signals, reenter the chart to find correction term to be ADDED to the bearing as read (include any SIGN changes). For example: suppose for the initial calibration the observed reading is 10.2° for the antenna positioned along radial for 10° azimuth, then

$$\begin{aligned} E &= AP - OB \\ &= 10.0^\circ - 10.2^\circ \\ &= -0.2^\circ \end{aligned}$$

The error will be plotted as -0.2° for the 10.2° position. Now, further suppose that during normal operation the observed bearing for an on-the-air signal is read as 10.2° . Reenter the chart as 10.2° and read error as -0.2° , then

$$\begin{aligned} TB &= OB + Error \\ &= 10.2 - 0.2^\circ \\ &= 10.0^\circ \end{aligned}$$

8.3.1 Mechanical Alidade

Calibrate as follows:

- (1) Prepare system for operation as described in Section 8.1.
- (2) Record the alidade readings for each antenna tested in Steps (5) through (8) of Section 8.1 and plot error versus OB.

8.3.2 Electronic Alidade with Strobe Rotation

- (1) Set digital bearing readout method (12) switch in Strobe Slew position.

- (2) Proceed as in Step (1) of 8.3.1.
- (3) An electronic cursor should be observed on the CRT display and be coincident with 0° on the engraved ring (mechanical alidade). If not exactly coincident, adjust STROBE CALIBRATION on the master control chassis to bring into coincidence. The digital bearing readout should read 000.0° .
- (4) Rotate electronic strobe by pressing either the CCW (22) or CW (23) buttons until the strobe exactly bisects the CRT signal pattern.
- (5) Read the observed bearing from the DIGITAL BEARING READ-OUT.
- (6) Plot error versus OB.

8.3.3 Electronic Alidade with Pattern Rotation

- (1) Set DBRM switch (12) in Pattern SLEW position.
- (2) Proceed as in 8.3.1 Step (1).
- (3) Check for cursor coincidence as in Step (3) of Section 8.3.2. If coincidence is NOT obtained DO NOT readjust STROBE CALIBRATION because some malfunction exists. Repeat Steps (1) to (3) of Section 8.3.2. It is important to push RESET anytime the DBRM switch position is changed.
- (4) Rotate CRT signal pattern by pressing either the CCW (22) or CW (23) buttons until the pattern is exactly bisected by the electronic strobe display vertically from the CRT center (0° position). The strobe may or may not be coincident with the 0° marker for the mechanical cursor. Use care to align the pattern to the strobe and not the 0° mark.
- (5) Read the observed bearing from the DIGITAL BEARING READ-OUT.
- (6) Plot error versus OB.

9. ADJUSTMENTS, MAINTENANCE AND TROUBLESHOOTING

The digital commutator and associated DF equipments have been in operation in excess of 3000 hours with no major breakdown or other difficulties requiring extensive troubleshooting. In general, the troubles experienced could be traced to: (1) incorrect voltage settings, (2) component failure - vacuum tubes or transistors, or (3) incorrect adjustments and operation.

Basic maintenance diagrams and troubleshooting procedures are furnished for the digital commutator. Descriptions of the modified portions of both the IP 137/GRD azimuth indicator and goniometer drive chassis and adjustments required are included also. Refer to TM-11-688 for general maintenance of all AN/TRD-4A equipment.

9.1 IP 137/GRD Chassis (Modified)

Because the Beverage DF set required a positive deflection on the CRT to display the synthesized antenna field pattern (amplitude comparison system), certain modifications to the signal proceeding circuits were necessary. Modifications to the azimuth indicator are shown in the shaded portions of Figure 31. The video detector circuit has been modified by reversing the diodes to produce an increasing positive voltage with increasing signal input to the R390/URR receiver. The control modulator has also been modified to produce linear positive deflection on the cathode ray tube by adjustment of the injection level of the 72-kHz subcarrier for optimum linearity when the video signal is increased from zero. Correct injection levels are shown in the CRT traces on Figure 31. Positive deflection requires that the 72-kHz carrier be minimized at the input to V303/M (an added amplifier stage) for zero video input. This is accomplished by injecting a 72-kHz signal of the correct amplitude and phase into the low side of the secondary of T302. AMPLITUDE (9) and PHASE (10) controls for SPOT SIZE adjustment are provided on the front panel of the IP 137 chassis (Figure 16). The controls are interacting and may need additional adjustments due to drift in the balancing circuit.

To initially set the SIZE ADJUST potentiometers in the grid circuits of V303/M and V303:

- (1) Set R390/URR GAIN to zero.
- (2) Set SIZE ADJUST Switch (11) on the front panel to TEST.

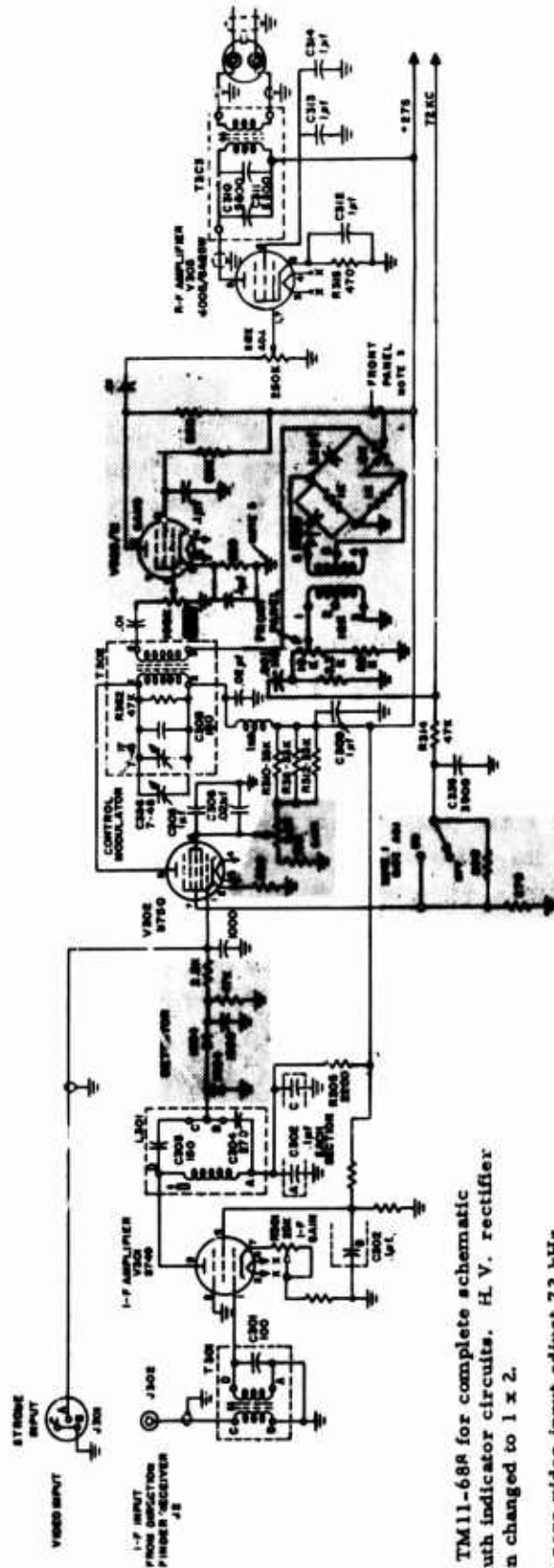

Notes

1. See TM11-688 for complete schematic of azimuth indicator circuits. H. V. rectifier has been changed to 1 x 2.
2. For zero video input adjust 72 kHs for minimum CRT spot size by front panel controls.
3. Normal position of SIZE switch is OFF. To adjust gain of V303 and V303/M after spot adjust, set SIZE switch ON and adjust size pots on V303 and V303/M for full deflection on CRT - DO NOT OVERDRIVE.

FIGURE 31. MODIFIED CIRCUIT OF IP 137 AZIMUTH INDICATOR

- (3) Adjust the two size controls on V303/M and V303 until full-scale deflection is obtained on the CRT display. The outer edge of the circle should just disappear behind the alidade mask on the CRT periphery. Do not overdrive because limiting may occur in the amplifiers.
- (4) Set SIZE Switch (11) to OPERATE.

In addition to the above modifications, the direct video input is used to couple the electronic strobe into the signal channel. Additional intensification of the strobe by Z-Axis modulation of the CRT has not proven feasible (works well with an auxiliary oscilloscope, such as a Tektronics 503, operating in parallel with the IP 137 CRT, however).

9.2 Digital Commutator

As mentioned earlier, the primary function of the digital commutator is to sample the inputs from an array of circularly disposed elements in a programmed manner and to provide a means whereby the amplitude and/or phase of the sampled signal can be displayed in synchronism with a circular (sine-cosine) sweep applied to a cathode ray tube. The objective is to display a synthesized antenna field pattern in the azimuth plane, based upon the assumption that all elements have identical response in both horizontal and vertical planes and at all frequencies, that can be used to accurately determine the azimuthal angle of arrival of a radio signal.

The digital commutation method permits a variety of methods for summing and phasing of elements, and spacing of elements used to form a beam. Specifically, it was desired to: (1) commutate a circular array of 180 antenna elements with an element located every 2° azimuth by turning ON or OFF 180 RF switches, one per antenna circuit, that are connected in parallel to a single radio receiver input; and (2) commutate a beam formed by the summation of any number of antennas, with any desired separation between sampled antenna inputs, continuously and repeatedly through 360° azimuth.

For discussion purposes, the commutator system can be divided into three sections:

- (1) RF Switch or Gate - There is one switch in series with each RF input; all switch outputs are connected in parallel (summed) to a receiver input.
- (2) Ring Counter - The purpose of the ring counter is to turn the RF switch ON or OFF in a programmed manner. There is one counter stage per RF Gate.

- (3) **Control Circuits** - Provides the clock or trigger pulses to the ring counter and contains the necessary circuits to synchronize the application of the clock pulses with external signal processing, display and bearing readout circuits.

A basic block diagram of the system was shown in Figure 6.

9.2.1 RF Chassis

A schematic of the RF Gate circuit was given in Figure 15. The purpose of the RF Gate is to pass or inhibit the signals present at a specific antenna input when instructed by the ring counter. The insertion gain of an individual stage (but loaded by 179 others at the common output) is approximately 10 dB from 2 to 20 MHz and decreasing to 0 dB at 30 MHz.

The push-pull arrangement shown in Figure 15 is used to minimize transients caused by the switching pulse. In normal operation, switching transients can be reduced below the receiver noise level.

9.2.1.1 Adjustment for Minimum Switching Transient

Since the switching pulse from the ring counter has a rise time of less than 1 microsecond, it is possible to produce switching transients in the signal channel within the frequency range of the receiver when an RF gate is biased ON or OFF. However, the gating pulse is injected in parallel (common mode) to both transistors in the push-pull (signal path) gate (see Figure 15); therefore, by common mode rejection in the amplifier-gate, it is possible to reduce transients, due to the switching pulse, below the noise level at the output of the digital commutator. Good rejection requires that the two 2N711B transistors be gain balanced. Experience has shown that if transistors are selected from the same production batch, a BALANCE potentiometer in the emitter circuits of the two transistors will provide adequate compensation.

Although all circuits have been properly adjusted just prior to shipment, switching noise at the audio output of the receiver or on the CRT display can be due to the following causes when the commutator is running and no signal is present. Interference due to switching transients is easily differentiated from normal noise by a chopped characteristic to the CRT display:

- (1) Improperly set power supply voltages,
- (2) Improper level of switching voltage to RF Gate,

- (3) Improper trigger drive level into the ring counter,
- (4) Improper setting of the gate GAIN control of the RF Gate,
- (5) Defective transistors in the RF Gate circuits, and
- (6) Improper adjustment of the gate BALANCE control.

Items (1), (2) and (3) can be recognized by omnidirectional switching transients on the CRT display. Items (4), (5) and (6) can be recognized by a directional characteristic of the switching noise on the CRT display because the difficulty lies in a particular stage of the commutator. The CRT alidade can be used to locate the defective stage.

Minimize switching transients as follows:

- (1) Operate system as described in Section 8.1 Steps (1) to (3), with no RF signal.
- (2) Use either the CRT on the azimuth indicator or connect an oscilloscope to the R390 IF OUTPUT. An oscilloscope is preferred.
- (3) Advance R390 RF Gain until a noise circle is noted on the CRT display or a convenient noise level is obtained on the oscilloscope trace.
- (4) Study display for characteristic indications of switching transient noise as described above. Determine the defective stage(s) if any.
- (5) If switching noise is present from all stages, check all voltages to commutator. Measure voltages to Master Control Chassis on Card 9 (Figure 29 and Figure 52), the load side of the series diodes. Use an oscilloscope, with DC input and internal trigger to check all switching voltage levels (180 circuits) from flip-flop to RF Board on the quick disconnect switch (Figure 29). Correct logic levels are -0.2V OFF and -6V ON. Check trigger level into ring counter chassis (rear panel BNC - Figure 29); logic level is 0 to -6V; pulse length is approximately 10 microseconds.
- (6) If switching transients are occasional and directional, adjust BALANCE control (Figure 15) on defective stage until the

switching transient is reduced below the R390 receiver noise.

9.2.1.2 Gain Adjustment

The GAIN of each amplifier is set individually but operating in the DF set - commutator not running.

- (1) Turn system ON as described in Section 7.1 and allow 5 to 10-minute warmup.
- (2) Remove front panel screws from the upper RF switch drawer and pull out as shown in Figure 32. Remove the board hold-down assembly.
- (3) Connect a signal generator to the 0° and 2° inputs (RF Cable 1) as shown in Figure 33, and set the frequency to approximately 5 MHz.
- (4) Connect a VTVM, oscilloscope, or RMS meter to the IF OUTPUT of the R390/URR receiver.
- (5) Push the STOP (14) and RESET (15) buttons.
- (6) Push the switch-lamp button at 0° (17) and note that only the 0° lamp is ON.
- (7) Refer to Figure 15 for Gain Control location. Note that there are two RF circuits per board. Antenna inputs to the drawer progress sequentially in a clockwise manner with the lower azimuthal number located on the outside edge of each band, see Table IV for assignments. Convenient groupings of RF Gate locations and related antenna portions are labeled on the chassis. Gain is increased by turning the potentiometer counterclockwise.
- (8) Tune the R390 to the signal frequency, and increase the signal input level until a convenient indication is obtained on the voltmeter or oscilloscope. Do not use an input signal level greater than 10 millivolts, however. (Nonlinear operation begins about 30 millivolts input.)
- (9) Turn the GAIN control on the RF switch - clockwise to reduce gain (base bias reduced toward zero volts DC).

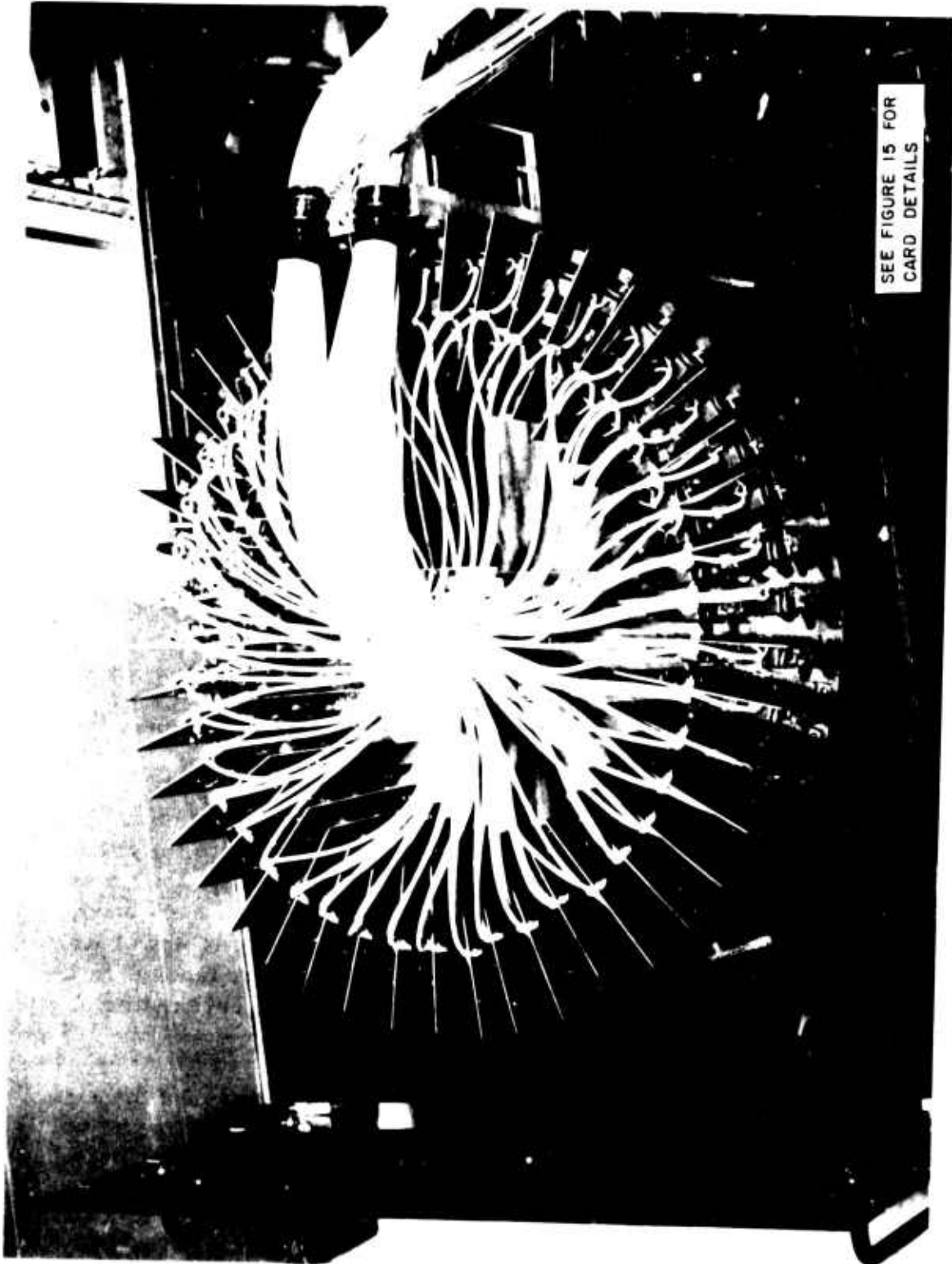

FIGURE 32. RF DRAWER EXTENDED

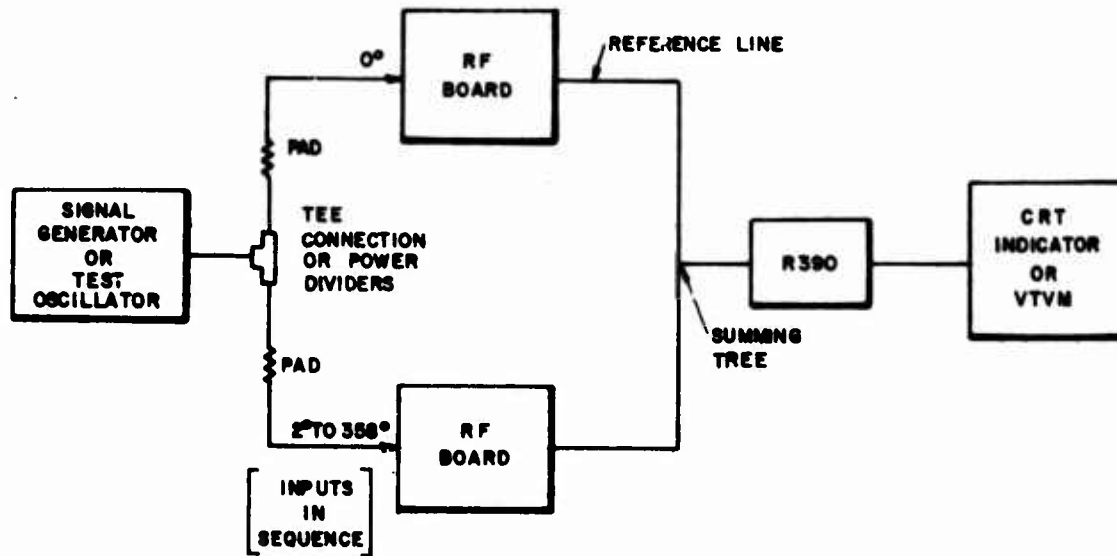

FIGURE 33. TEST CIRCUIT FOR RF GAIN ADJUST

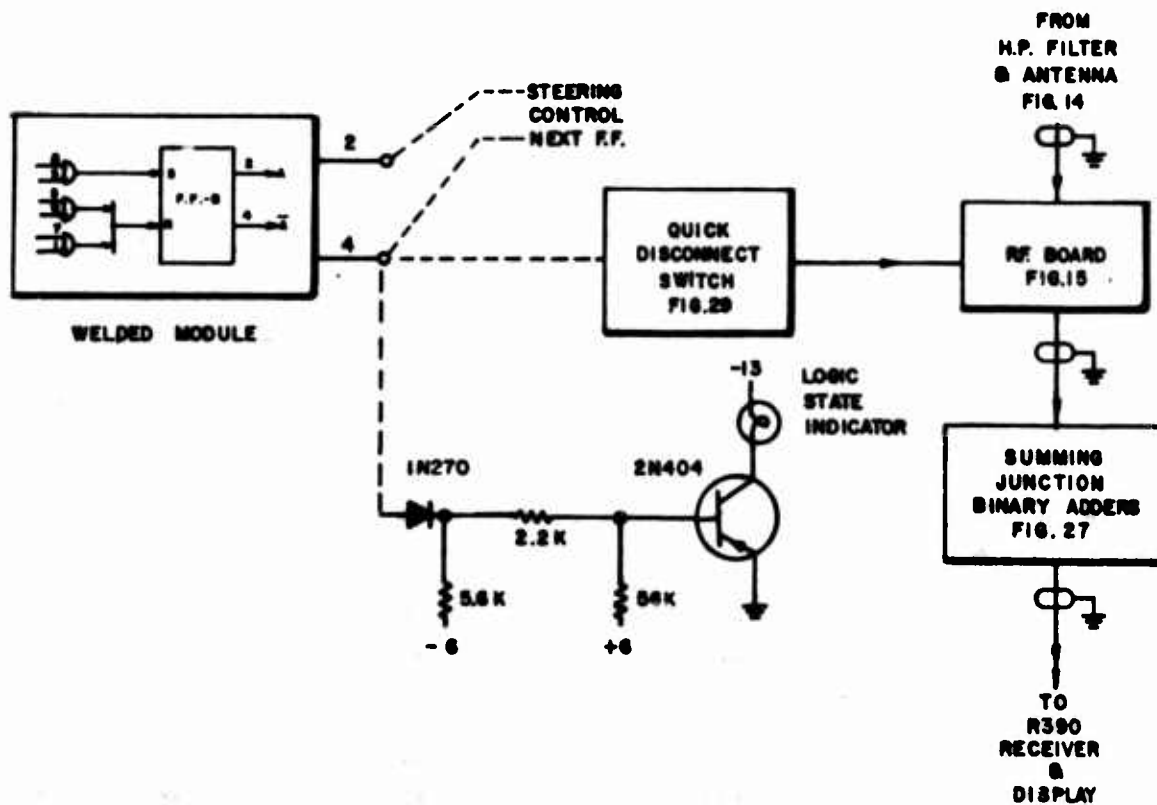

FIGURE 34. BLOCK DIAGRAM - ONE COMMUTATOR STAGE

TABLE IV. WIRING LISTS FOR RING COUNTER STAGES TO RF SWITCH

Ring Counter Board/Pin No.	Wire Color	Disconnect Switch Position Row/Column	Wire Color	R. F. Switch Antenna Pin Position No.	Ring Counter Board/Pin No.	Wire Color	Disconnect Switch Position Row/Column	Wire Color	R. F. Switch Antenna Pin Position No.
0135	BR	10-23	GY	346-3	0435	BR	10-17	GY	76-5
0133	R	9-23	BR	348-5	0433	R	9-17	BR	78-3
0131	O	8-23	R	350-3	0431	O	8-17	R	80-5
0129	Y	7-23	O	352-5	0429	Y	7-17	O	82-3
0127	GN	6-23	Y	354-3	0427	GN	6-17	Y	84-5
0125	BL	5-23	GN	356-5	0425	BL	5-17	GN	86-3
0123	V	4-23	BL	358-3	0423	V	4-17	BL	88-5
0121	BR	10-22	V	6-5	0421	BR	10-16	V	90-3
0119	R	9-22	BR	2-3	0419	R	9-16	BR	92-5
0117	O	8-22	R	4-5	0417	O	8-16	R	94-3
0115	Y	7-22	O	6-3	0415	Y	7-16	O	96-5
0113	GN	6-22	Y	8-5	0413	GN	6-16	Y	98-3
0111	BL	5-22	GN	10-3	0411	BL	5-16	GN	100-5
0109	V	4-22	BL	12-5	0409	V	4-16	BL	102-3
0105	GY	3-22	V	14-3	0405	GY	3-16	V	104-5
0235	BR	10-21	GY	16-5	0535	BR	10-15	GY	106-3
0233	R	9-21	BR	18-3	0533	R	9-15	BR	108-5
0231	O	8-21	R	20-5	0531	O	8-15	R	110-3
0229	Y	7-21	O	22-3	0529	Y	7-15	O	112-5
0227	GN	6-21	Y	24-5	0527	GN	6-15	Y	114-3
0225	BL	5-21	GN	26-3	0525	BL	5-15	GN	116-5
0223	V	4-21	BL	28-5	0523	V	4-15	BL	118-3
0221	BR	10-20	V	30-3	1035	BR	10-5	GY	254-5
0735	BR	10-11	GY	166-3	1033	R	9-5	BR	258-3
0733	R	9-11	BR	168-5	1031	O	8-5	R	260-5
0731	O	8-11	R	170-3	1029	Y	7-5	O	262-3
0729	Y	7-11	O	172-5	1027	GN	6-5	Y	264-5
0727	GN	6-11	Y	174-3	1025	GL	5-5	GN	266-3
0725	BL	5-11	GN	176-5	1023	V	4-5	BL	268-5
0723	V	4-11	BL	178-3	1021	BR	10-4	V	270-3
0721	BR	10-10	V	180-5	1019	R	9-4	GN	272-5
0719	R	9-10	BR	182-3	1017	O	8-4	BL	274-3
0717	O	8-10	R	184-5	1015	Y	7-4	V	276-5
0715	Y	7-10	O	186-3	1013	GN	6-4	BR	278-3
0713	GN	6-10	Y	188-5	1011	BL	5-4	R	280-5
0711	BL	5-10	GN	190-3	1009	V	4-4	O	282-3
0709	V	4-10	BL	192-5	1005	GY	3-4	Y	284-5
0705	GY	3-10	V	194-3	1135	BR	10-3	GN	286-3
0635	BR	10-9	GY	196-5	1133	R	9-3	BR	288-5
0633	R	9-9	BR	198-3	1131	O	8-3	R	290-3
0631	O	8-9	R	200-5	1129	Y	7-3	O	292-5
0629	Y	7-9	O	202-3	1127	GN	6-3	Y	294-3
0627	GN	6-9	Y	204-5	1125	BL	5-3	GN	296-5
0625	BL	5-9	GN	206-3	1123	V	4-3	GL	298-3
0623	V	4-9	BL	208-5	1121	BR	10-2	V	300-5
0621	BR	10-8	V	210-3					

TABLE IV. WIRING LISTS FOR RING COUNTER STAGES TO RF SWITCH (Cont'd)

Ring Counter Board/Pin No.	Wire Color	Disconnect Switch Position Row/Column	Wire Color	R. F. Switch Antenna Pin Position No.	Ring Counter Board/Pin No.	Wire Color	Disconnect Switch Position Row/Column	Wire Color	R. F. Switch Antenna Pin Position No.
0219	R	9-20	BR	32-5	0521	BR	10-14	V	120-5
0217	O	8-20	R	34-3	0519	R	9-14	BR	122-3
0215	Y	7-20	O	36-5	0517	O	8-14	R	124-5
0213	GN	6-20	Y	38-3	0515	Y	7-14	O	126-3
0211	BL	5-20	GN	40-5	0513	GN	6-14	Y	128-5
0209	V	4-20	BL	42-3	0511	BL	5-14	GN	130-3
0205	GY	3-20	V	44-5	0509	V	4-14	BL	132-5
0335	BR	10-19	GY	46-3	0505	GY	3-14	V	134-3
0333	R	9-19	BR	48-5	0635	BR	10-13	GY	136-5
0331	O	8-19	R	50-3	0633	R	9-13	BR	138-3
0329	Y	7-19	O	52-5	0631	O	8-13	R	140-5
0327	GN	6-19	Y	54-3	0629	Y	7-13	O	142-3
0325	BL	5-19	GN	56-5	0627	GN	6-13	Y	144-5
0323	V	4-19	BL	58-3	0625	BL	5-13	GN	146-3
0321	BR	10-18	V	60-5	0623	V	4-13	BL	148-5
0319	R	9-18	BR	62-3	0621	BR	10-12	V	150-3
0317	O	8-18	R	64-5	0619	R	9-12	BR	152-5
0315	Y	7-18	O	66-3	0617	O	8-12	R	154-3
0313	GN	6-18	Y	68-5	0615	Y	7-12	O	156-5
0311	BL	5-18	GN	70-3	0613	GN	6-12	Y	158-3
0309	V	4-18	BL	72-5	0611	BL	5-12	GN	160-5
0305	GY	3-18	V	74-3	0609	V	4-12	BL	162-3
0819	R	9-8	BR	212-5	0605	GY	3-12	V	164-5
0817	O	8-8	R	214-3	1119	R	9-2	BR	302-3
0815	Y	7-8	O	216-5	1117	O	8-2	R	304-5
0813	GN	6-8	Y	218-3	1115	Y	7-2	O	306-3
0811	BL	5-8	GN	220-5	1113	GN	6-2	Y	308-5
0809	V	4-8	BL	222-3	1111	BL	5-2	GN	310-3
0805	GY	3-8	V	224-5	1109	V	4-2	BL	312-5
0935	BR	10-7	GY	226-3	1105	GY	3-2	V	314-3
0933	R	9-7	BR	228-5	1235	BR	10-1	GY	316-5
0931	O	8-7	R	230-3	1233	R	9-1	BR	318-3
0929	Y	7-7	O	232-5	1231	O	8-1	R	320-5
0927	GN	6-7	Y	234-3	1229	Y	7-1	O	322-3
0925	BL	5-7	GN	236-5	1227	GN	6-1	Y	324-5
0923	V	4-7	BL	238-3	1225	BL	5-1	GN	326-3
0921	BR	10-6	V	240-5	1223	V	4-1	BL	328-5
0919	R	9-6	BR	242-3	1221	BR	10-24	V	330-3
0917	O	8-6	R	244-5	1219	R	9-24	BR	332-5
0915	Y	7-6	O	246-3	1217	O	8-24	R	334-3
0913	GN	6-6	Y	248-5	1215	Y	7-24	O	336-5
0911	BL	5-6	GN	250-3	1213	GN	6-24	Y	338-3
0909	V	4-6	BL	252-5	1211	BL	5-24	GN	340-5
0905	GY	3-6	V	254-3	1209	V	4-24	BL	342-3
					1205	GY	3-24	V	344-5

- (10) Increase the gain adjust counterclockwise until the output meter indication goes through a maximum. Check tuning of R390.
- (11) Back off the gain control - clockwise until the output drops 3 dB below the maximum level obtained in Step (10). Note the output meter level and use as a reference for adjustment of all other RF switches.

CAUTION: Reduce gain as described; DO NOT continue to turn adjustment counterclockwise since the RF switch will be overdriven by the switching pulse into the non-linear region. The bias level at each transistor base must be less negative than the value obtained in Step (10).

- (12) Depress the RESET button to turn the 0° circuit OFF.
- (13) Push the switch-lamp for the 2° circuit, and repeat Steps (9), (10) and (11) but take care that the same reading is obtained in Step (11) for the 0° circuit. Check R390 tuning.
- (14) Push RESET and set 0° circuit ON to check reference level.
- (15) Remove input for the 2° circuit and reconnect to the 4° circuit. Push RESET.
- (16) Push the 4° switch lamp ON and repeat Steps (13) and (14).
- (17) Repeat Steps (13) through (15) for all other RF switches (6° to 358°). See Table III for input assignments - RF inputs 330° to 358° and 0° to 148° are located in the top RF drawer, and 150° to 328° are located in the bottom RF drawer.

9.2.2 Ring Counter

Because each RF gate is essentially autonomous (although all are summed to a common output), the number and positions of the gates that may be turned ON at any instant are controlled by a voltage applied to each gate from an associated flip-flop stage within a ring counter circuit. The ring counter is a specialized circuit formed from shift register type flip-flop stages. It is the incorporation of shift register flip-flops that provides the capability of carrying more than one bit or count (more than one RF input sampled at the same time) in the ring counter. If a multiple count is set up, the counts do not have to be adjacent or consecutive but can be spaced at will within the counter and sequentially clocked around the counter while maintaining the preset count separation.

Consecutive counter stages correspond to consecutive antenna circuits in a circular array, i. e., 0° , 2° , 4° , 6° , ..., 356° and 358° . To sum elements into an array, a stationary beam is first established symmetrically about some reference element, say 0° , by manually setting the desired bits (counts) into the proper register locations by push button switches on the beamformer panel (Figure 28). For example, if five consecutive elements are to be summed, the bits would be set into register location for 356° , 358° , 0° , 2° and 4° . A sync pulse corresponding to 0° on the CRT display enables a gate (hold-off circuit) so that clock pulses, derived from a motor driven rotary optical pulse generator (optical shaft encoder) that is mechanically coupled to the sine-cosine indicator goniometer, triggers the register. The mechanical coupling maintains synchronism between commutation and CRT display.

The clock pulses are applied in parallel to all stages and to both sides of each flip-flop state of the ring counter (shift register connection) through a pedestal gate. Refer to Reference of Section 4.2.7 (3) for more detailed theory of ring counter operation.

In order to visually determine which stages are ON, particularly for the static beamforming process, an incandescent lamp with its driving circuit is made an integral part of each stage in the ring counter. The design is such that the lamp glows whenever the RF switch associated with the respective flip-flop stage is ON (Figure 28).

A block diagram of one complete stage, shift register flip-flop, RF Gate and logic state indicator is shown in Figure 34. There are 180 such stages in the commutator. Schematic details of the flip-flop stages are not necessary because of the welded construction of each unit. (If a failure is traced to a welded module, replace the entire unit - do not attempt repair.)

A representative ten-stage ring counter is shown in Figure 35. To obtain 180-stage ring counter operation requires that 180 units identical to that within the shaded portion be connected as shown. A printed circuit board containing twelve flip-flop stages and emitter following trigger amplifier is shown as part of Figure 36. There are fifteen boards identical in every way except the trigger amplifier (emitter follower) shown is used to drive twenty-four stages (two boards) of the ring counter. A view of the ring counter chassis is shown in Figure 37; note that corresponding antenna position numbers are marked on the top of some welded modules.

9.2.3 Logic Control and Bearing Readout Circuits

A logic block diagram of the control circuits for the ring counter and logic circuits associated with the generation of the electronic strobe and

NOTE: SEE REFERENCE 3 OF SECTION 4.2.7 FOR DESCRIPTION OF OPERATION.

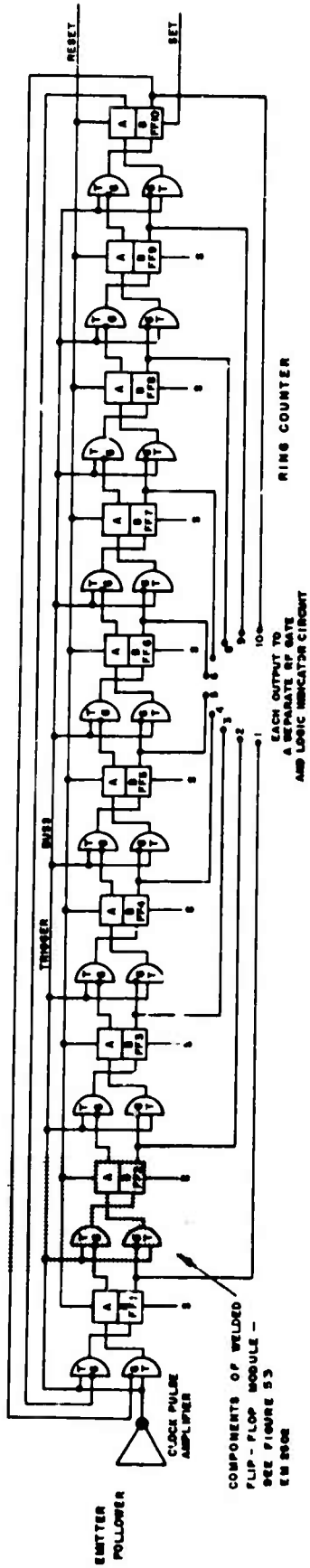

FIGURE 35. TEN-STAGE EXAMPLE OF RING COUNTER CIRCUITS

EMITTER FOLLOWER CLOCK PULSE AMPLIFIERS ONE FOR EACH TWO BOARDS.

THERE ARE 15 IDENTICAL BOARDS IN RING COUNTER CHASSIS SEE TABLE III FOR RING COUNTER CABLING TO RF BOARD & INDICATOR POSITIONS.



FIGURE 36. DIGITAL LOGIC BOARD FOR TWELVE STAGES OF RING COUNTER



FIGURE 37. RING COUNTER CHASSIS

bearing readout counter is shown in Figure 38. Logic diagrams of each printed circuit board are shown in Figures 39 through 43. Associated wiring lists and function designations are given in Table V. Master Control boards 1 through 9 are shown in the chassis in Figure 44 and individually in Figures 45 through 52. Welded module designations are specified in Figure 38 and the wiring diagrams. Specifications for the modules are given in Figure 53. Schematics of special circuits are given in Figures 54A through 54E. Figure 55 describes the time relationships of various pulse trains within the commutator, and Figures 56 and 57 show oscilloscope traces at various test points within the Master Control chassis. Reference signals are shown in the upper trace of each sequence.

9.3 Goniometer Chassis Modification

The DFG-2 Goniometer chassis has been modified in the following manner: (refer to Figure 18 and TM-11-688):

- (1) The signal goniometer has been replaced by an optical shaft encoder.
- (2) The indicator drive motor, O-ring drive assembly and pulleys have been replaced by an 1800-rpm single-phase synchronous motor and gear belt drive (a spare belt is provided).

The optical shaft encoder required a special drive and mount assembly as detailed in Figure 58.

NOTE: Extreme care must be taken in the assembly or disassembly of the encoder unit or drive assembly. Correct shaft alignment is absolutely necessary to prevent damage to the encoder disk. Particular attention is required for proper alignment of the oldham coupling.

9.4 Troubleshooting

Figures 38 through 57 can be used to troubleshoot all logic circuits in the commutator. Typical pulse widths are shown on Figures 56 and 57. Detailed troubleshooting symptoms cannot be given since the malfunctions to date have been minimal and random. It is recommended that an orderly procedure be established to trace the source of a circuit failure. ALWAYS CHECK FUSES AND VOLTAGE LEVELS before making exhaustive circuit checks (see Figure 59 for fuse size and location). Refer to TM-11-688 and TM-11-856 for troubleshooting of the Azimuth Indicator, R390/URR receiver, and goniometer.

TABLE OF SWITCH ASSIGNMENT

- SW-1 - MASTER AC POWER
- SW-2 - DIGITAL READOUT ROTATION METHOD
- SW-3 - CCW SLEW
- SW-4 - CW SLEW
- SW-5 - STOP
- SW-6 - RESET
- SW-7 - START
- SW-8 - OPERATE/OFF/TEST

NOTE: ALL PEDESTAL GATES THAT HAVE NO CONNECTION ON PEDESTAL SIDE DO NOT REQUIRE GATING VOLTAGES.

NOTE: SW 8 IS SHOWN IN "OFF"

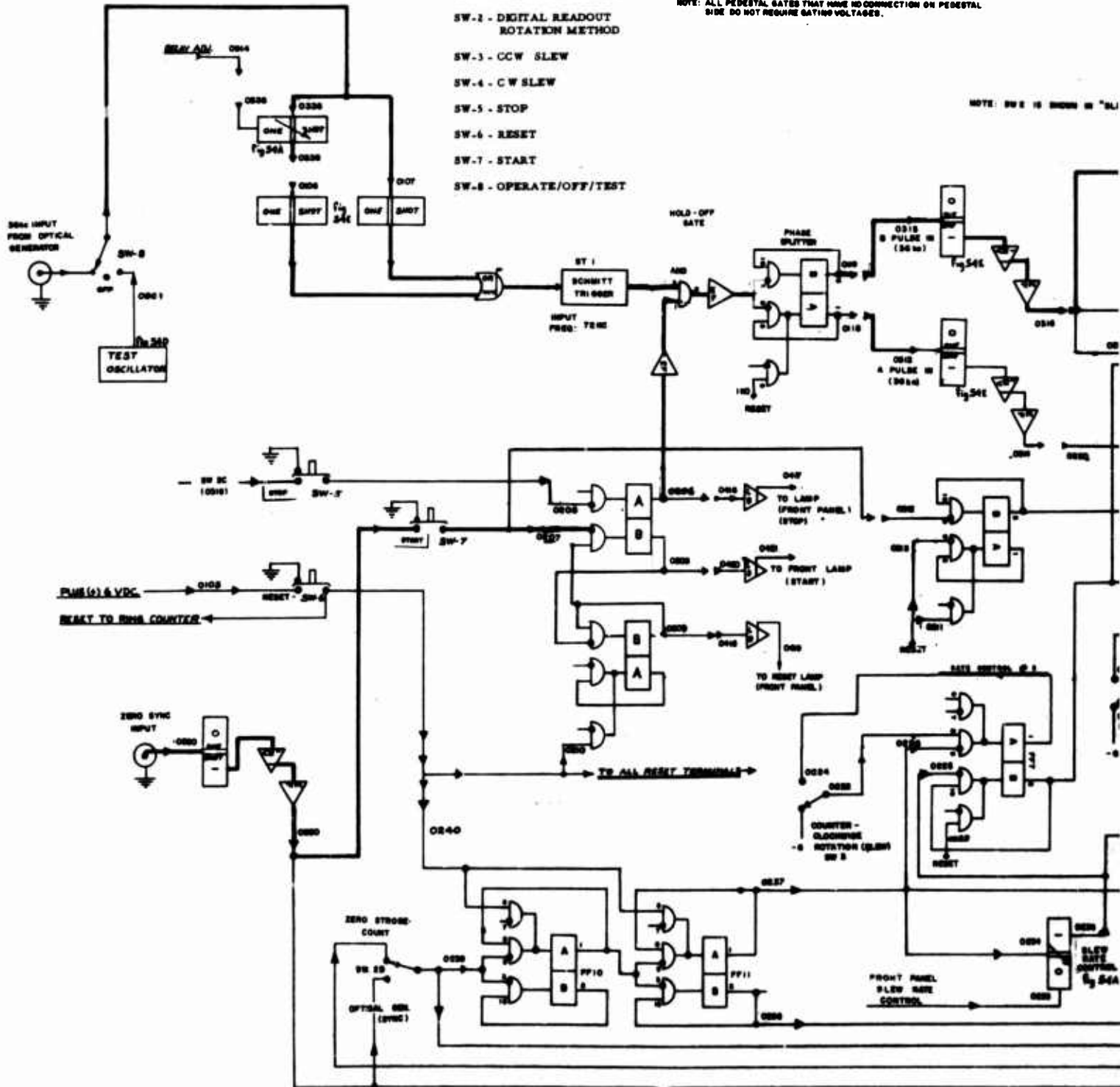
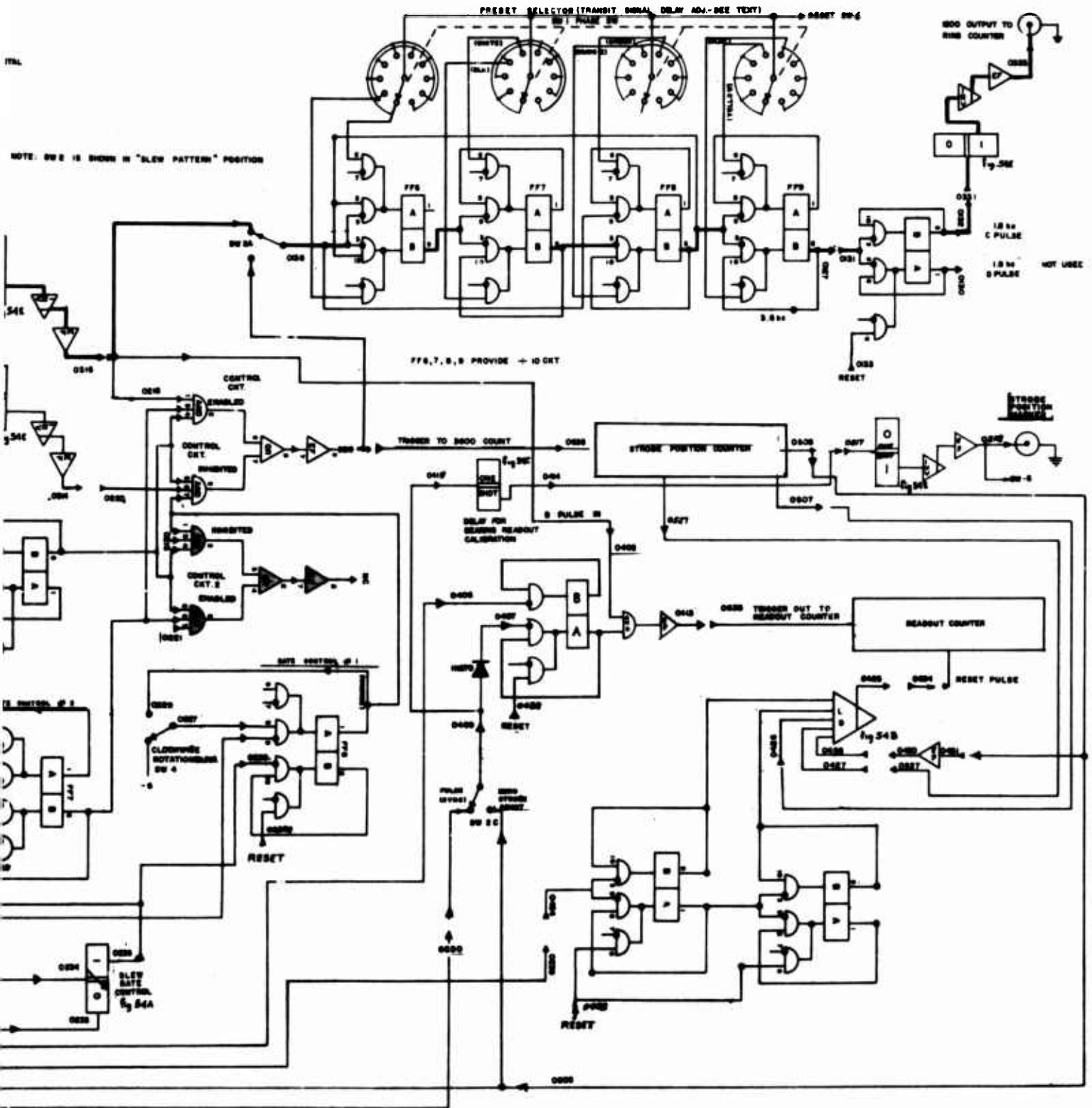

FIGURE 23. BLOCK DIAGRAM OF MASTER CONTROL SYSTEM



GRAM OF MASTER CONTROL CHASSIS

2

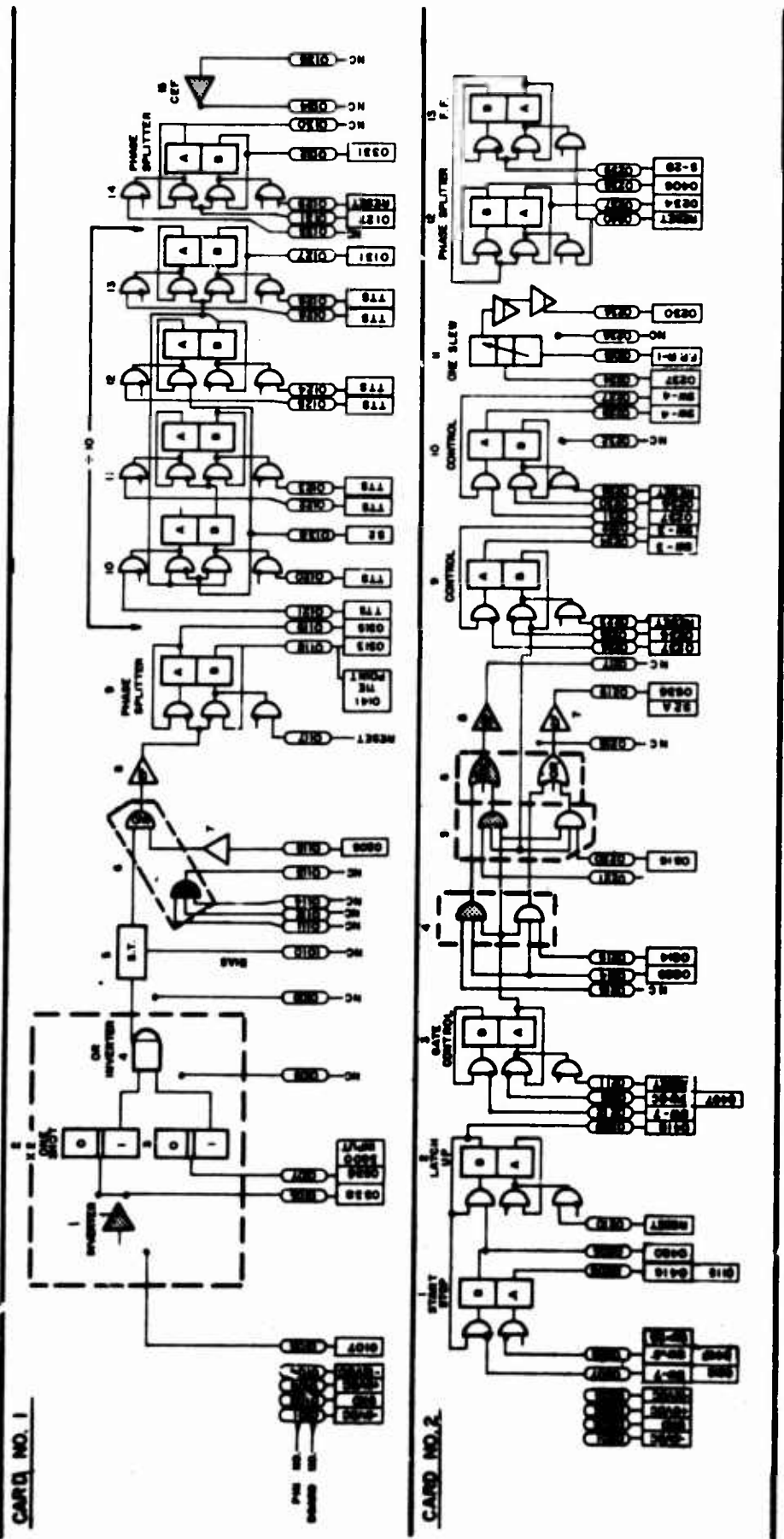
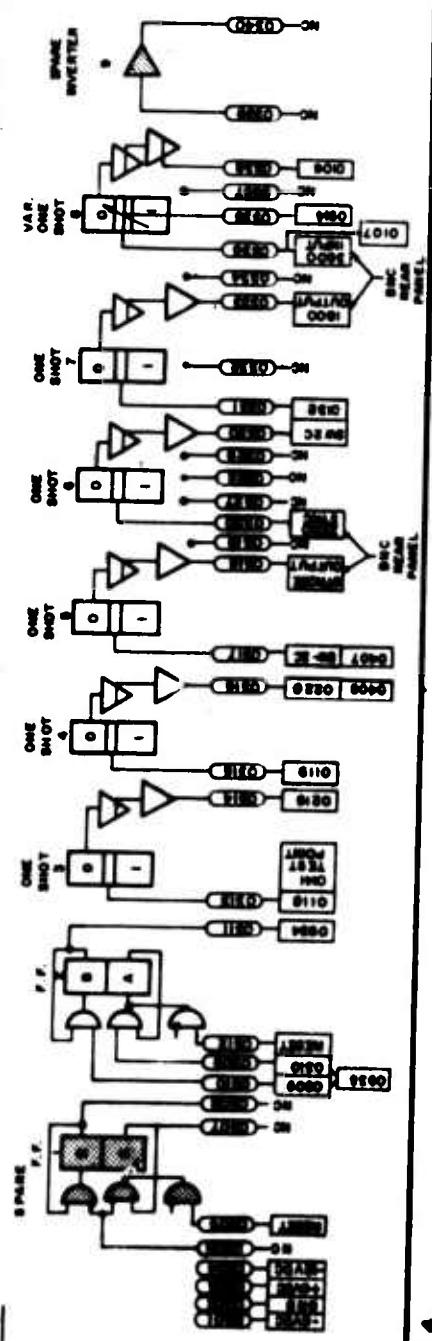

FIGURE 39. LOGIC DIAGRAMS FOR MASTER CONTROL BOARDS 1 AND 2

CARD NO. 3



CARD NO. 4

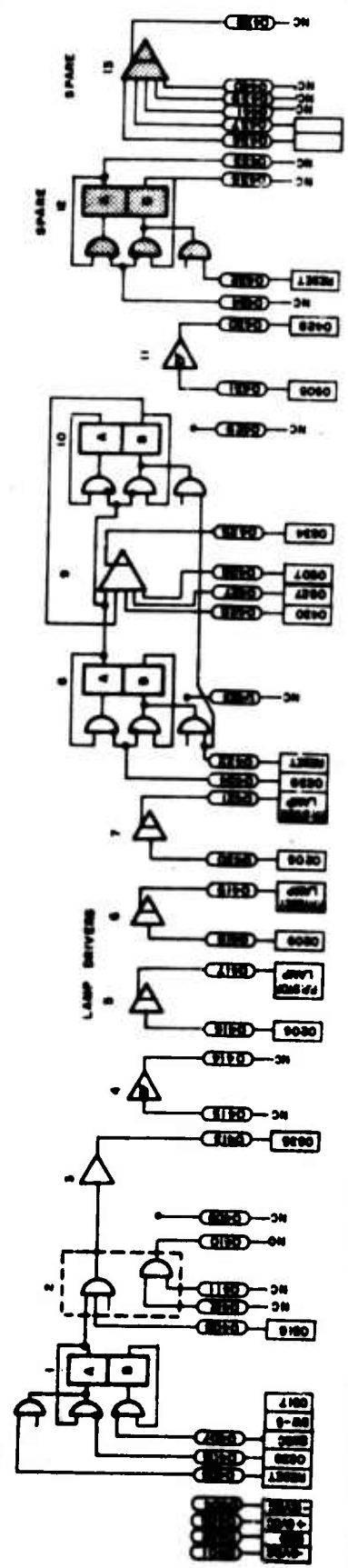

FIGURE 40. LOGIC DIAGRAMS FOR MASTER CONTROL BOARDS 3 AND 4

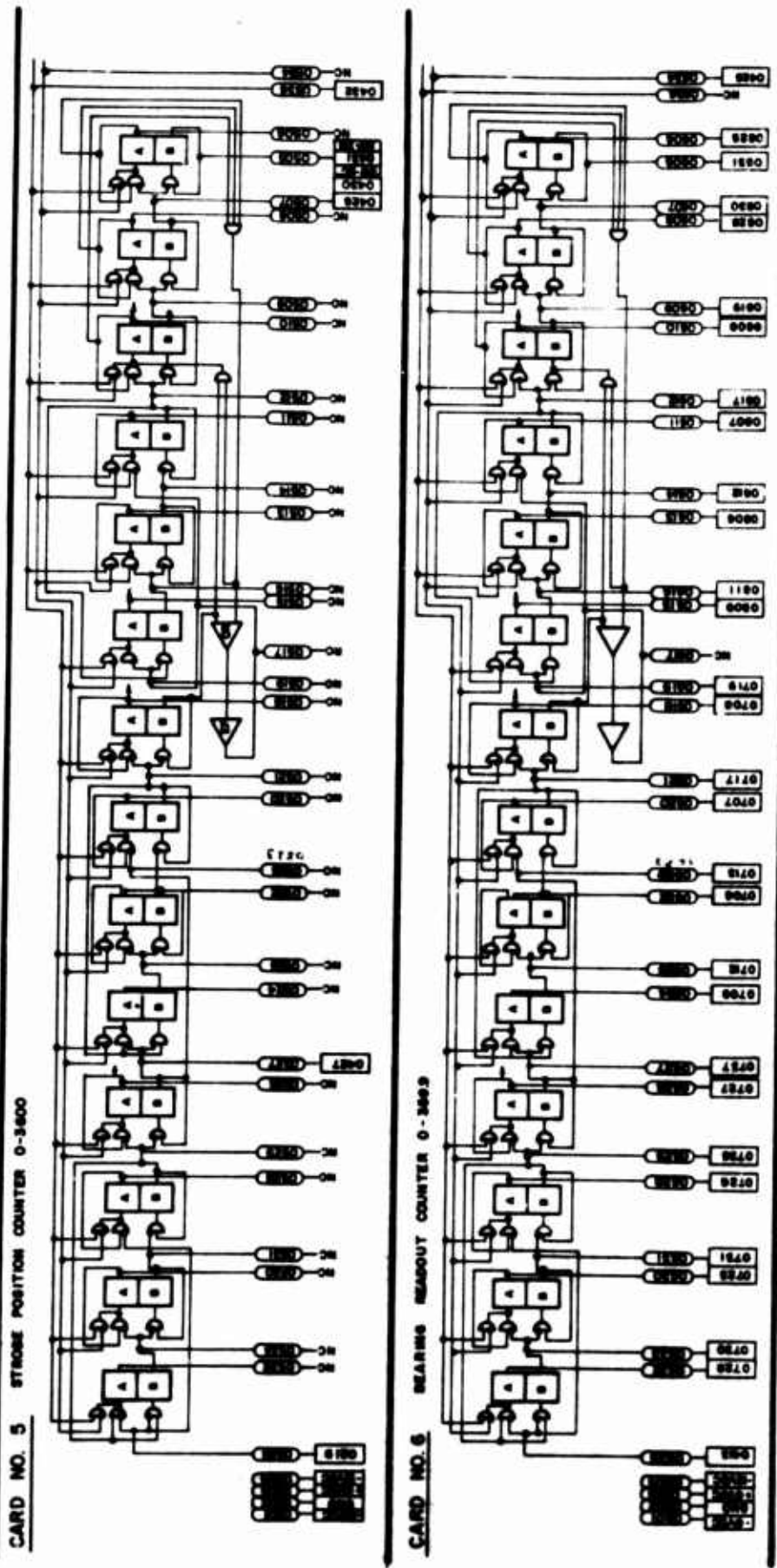
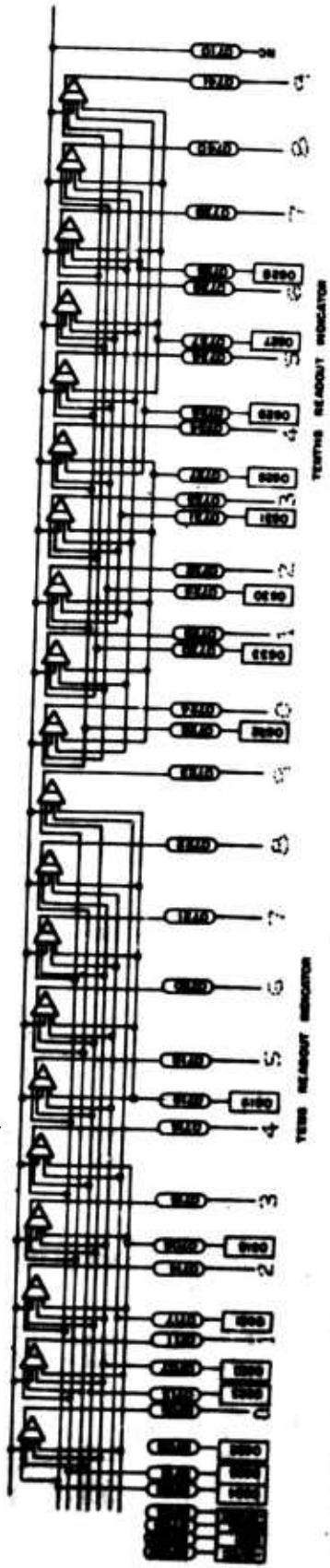

FIGURE 41. LOGIC DIAGRAMS FOR MASTER CONTROL BOARDS 5 AND 6

CARD NO. 7

BINARY TO DECIMAL DECODER AND LAMP DRIVER FOR INITIAL REABOUT



CARD NO. 8

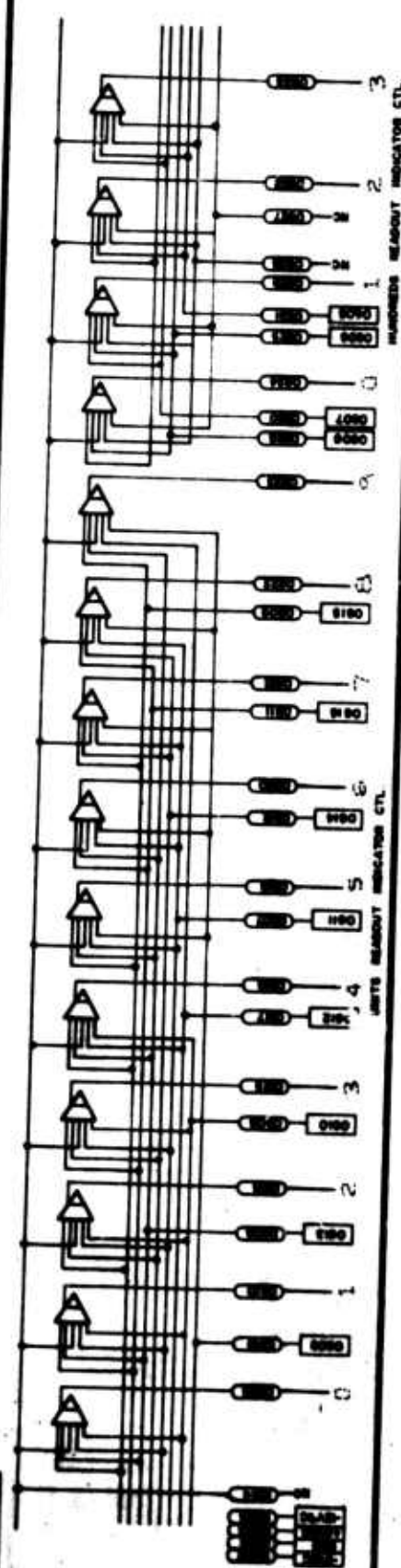
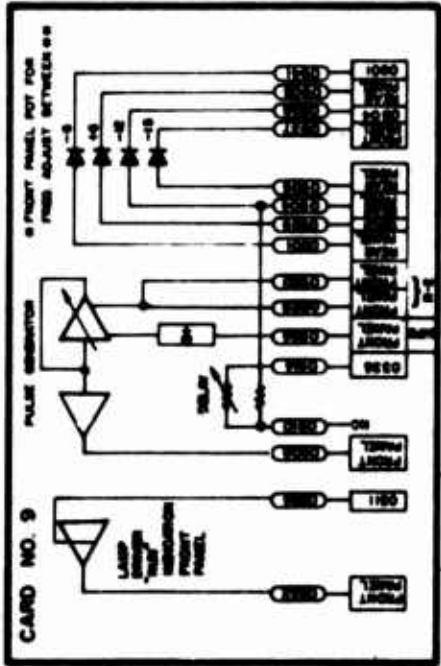
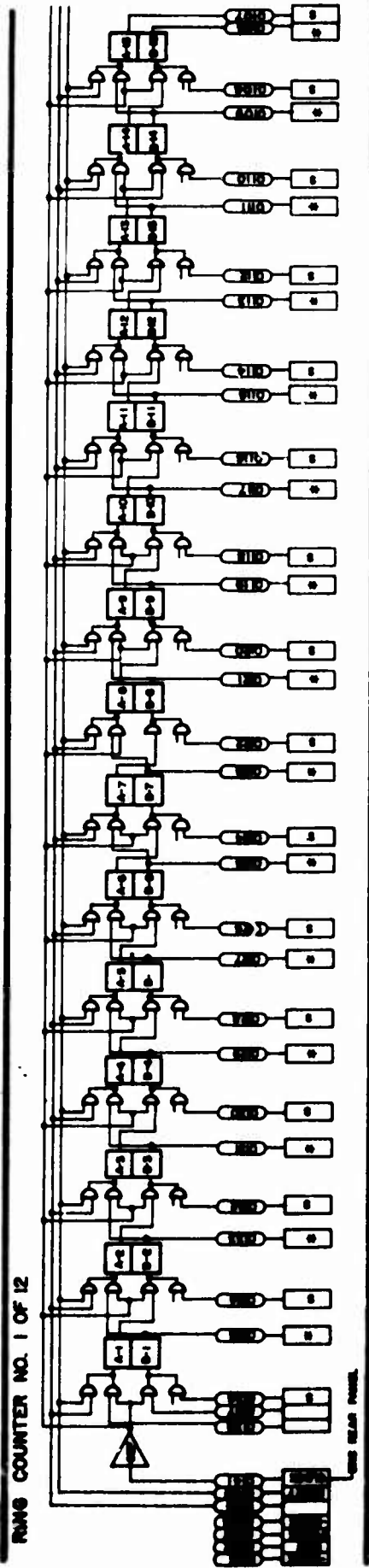

FIGURE 42. LOGIC DIAGRAM FOR MASTER CONTROL BOARDS 7 AND 8



The first two digits of the ring board contacts index according to the board number, i. e., 0138 board 1 becomes 0238 board 2, etc., to 1238, board 12.
 See Table III for wiring list

FIGURE 43. LOGIC DIAGRAMS FOR BOARD NO. 9 OF MASTER CONTROL AND REPRESENTATIVE RING COUNTER BOARD

TABLE V. WIRING LISTS FOR MASTER CONTROL CHASSIS

From Board & Pin No.	To Board & Pin No.	Function	From Board & Pin No.	To Board & Pin No.	Function	From Board & Pin No.	To Board & Pin No.	Function	From Board & Pin No.	To Board & Pin No.	Function
0101	0201 Front Panel	-6vdc Buss	0120	Signal Trans- mit Delay Adj. Front Panel SW-1	Preset ± 10	0233	Front Panel R1	Slow Rate Control	0236	0406	Gate Control Input
0102	0202 Chassis Gnd.	Ground Buss	0129	0117	Reset	0234	0237	Slow Rate Trigger	0239	SW-2B	Gate Control Input
0103	0203 Front Panel	6vdc Buss	0130	No Connection		0238	No connection		0240	0223	Reset
0104	0104 Front Panel	-12vdc	0131	0127	Divide by 2 Input	0236	0230	Slow Rate Output	0241	No connection	
0105	0107	36 hr Test	0132	0331	C-Pulse Output	0237	0234	Slow Rate Trigger			
0106	0330	36 hr Delay									
0107	0336 Rear Panel thru 0105	36 hr Input from Optical Generator	0133	No Connection							
0108 thru 0114	No Connection		0140								
0115	0206	Gate Control	0141	Used as tie point for B-Pulse							
0116	No Connection										
0117	Front Panel 0129	Reset SW-6 (6vdc) Reset									
0118	0313	A-Pulse									
0119	0315	B-Pulse									
0120 thru 0126	Signal Trans- mit Delay Adj. Front Panel SW-1	Preset ± 10 Circuit									
0127	0131	Divide by 10 Output									
0201	0101 0301	-6vdc Buss	0210	No connection	Spare Gate circuit output	0301	0201 0401	-6vdc Buss	0317	0414	Delayed Strobe Output
0202	0100 0302	Ground Buss	0219	0030	Input to Strobe Counter	0302	0201 0401	Gnd Buss	0318	SW-3	Strobe Marker Pulse
0203	0103 0303	6 vdc Buss	0220	0316	B-Pulse	0303	0201 0401	6 vdc Buss	0319	No Connection	
0204	0104 0304	-12 vdc Buss	0221	No connection	Spare gate circuit input	0304	0201 0401	-12vdc Buss	0320	Rear Panel	Zero Sync
0205	0420	Start Indicator	0222	CCW Switch SW-3	Slow direction	0305	0210	Reset	0321	No Connection	
0206	0416 0115	Stop Indicator Gate Control	0223	0211	Reset	0306	No Connection	Spare F. F. Input	0322 thru 0329	No Connection	
0207	0212 Start SW-7	Start Pulse	0224	CCW Switch SW-3	Slow direction	0307	No Connection	Spare F. F. Output	0330	SW-2B, SW-2C	Zero Sync
0208	SW-5	Stop Pulse	0225	0236	Gate control input	0308	No Connection	Spare F. F. Output	0331	0132	C-Pulse
0209	0410	Reset Indicator	0226	0237	Gate control input	0309	0926	Front panel Ring	0332	Rear Panel	C-Pulse
0210	0117	Reset	0227	CW Switch SW-4	Slow direction	0310	0926	Counter Ind- icator Control	0333	0914	Transit Delay Adj. (36 hr)
0211	0210	Reset	0228	0223	Reset	0311	0924	Indicator Con- trol Output	0334	0107	Transit Delay Input (36 hr)
0212	0207, SW-7	Start Pulse	0229	CW Switch SW-4	Slow direction	0312	0305	Reset	0335	0106	Transit Delay Output (36 hr)
0213	Stop switch SW-5	Stop Pulse	0230	0236	Gate control input	0313	0110 0141	A-Pulse Tie Point	0336	No Connection	Spare CEP Output
0214	0209	Gate Control	0231	0237	Gate control input	0314	0215	A-Pulse	0337	No Connection	Spare CEP Input
0215	0314	A-Pulse	0232	No connection		0315	0119	B-Pulse	0338	No Connection	
0216	No connection	Spare gate circuit input				0316	0220 0400	B-Pulse	0339	No Connection	
0217	No connection	Spare gate circuit output							0340	No Connection	

NOTE: FIRST TWO DIGITS OF BOARD AND PIN NO. REFER TO PRINTED CIRCUIT BOARD NUMBER ON MASTER CONTROL CHASSIS; LAST TWO DIGITS REFER TO PIN NO. ON THE PRINTED CIRCUIT BOARD CONNECTOR. FOR EXAMPLE, 0237 REFERS TO PIN 17 OF BOARD NO. 2.

TABLE V. WIRING LISTS FOR MASTER CONTROL CHASSIS (Cont'd)

From Board & Pin No.	To Board & Pin No.	Function	From Board & Pin No.	To Board & Pin No.	Function	From Board & Pin No.	To Board & Pin No.	Function	From Board & Pin No.	To Board & Pin No.	Function
0401	0301 0501	-6vdc Buss	0418	0209	Reset Indicator Driver	0601	0501 0702	-6vdc Buss	0613	0006	Binary Output to Decimal Converter
0402	0301 0501	Ground Buss	0419	Reset Lamp (12)	Reset Indicator Driver	0602	0502 0701	Ground Buss	0614	0012	Binary Output to Decimal Converter
0403	0301 0501	6vdc Buss	0420	0205	Start Indicator Driver	0603	0503 0703	6vdc Buss	0615	0009	Binary Output to Decimal Converter
0404	0301 0501	-12 vdc Buss	0421	Start Lamp (13)	Start Indicator Driver	0604	0504 0704	-12vdc Buss	0616	0011	Binary Output to Decimal Converter
0405	0305	Reset	0422	0405	Reset	0605	0031	Binary Output to Decimal Converter	0617	No Connection	
0406	0230	Gate Control Input	0423	No Connection		0606	0025	Binary Output to Decimal Converter	0618	0706	Binary Output to Decimal Converter
0407	0409 thru 0470	Readout Counter Gate Control	0424	0239	Gate Control Input	0607	0030	Binary Output to Decimal Converter	0619	0719	Binary Output to Decimal Converter
0408	0316	B-Pulse	0425	0634	Readout Reset	0608	0020	Binary Output to Decimal Converter	0620	0707	Binary Output to Decimal Converter
0409	SW-2C, 0415 & Readout Counter 0407 thru 0470	Gate Control	0426	0507	Gate Input	0609	0028	Binary Output to Decimal Converter	0621	0717	Binary Output to Decimal Converter
0410	No Connection	Spare Gate Output	0427	0527	Gate Input	0610	0000	Binary Output to Decimal Converter	0622	0706	Binary Output to Decimal Converter
0411 & 0417	No Connection	Spare Gate Input	0428	0430	Gate Input	0611	0007	Binary Output to Decimal Converter	0623	0713	Binary Output to Decimal Converter
0413	0635	B-Pulse	0429	No Connection		0612	0017	Binary Output to Decimal Converter	0624	0709	Binary Output to Decimal Converter
0414	0317	Delayed Strobe Output	0430	0428	CEP Output Zero Strobe	0613	0012	Binary Output to Decimal Converter	0625	0712	Binary Output to Decimal Converter
0415	0409	Undelayed Strobe Pulse	0431	0505	CEP Input Zero Strobe	0614	0027	Binary Output to Decimal Converter	0626	0726	Binary Output to Decimal Converter
0416	0206	Stop Indicator Driver	0432	0312	Reset	0615	0735	Binary Output to Decimal Converter	0627	0737	Binary Output to Decimal Converter
0417	Stop Lamp (11)	Stop Indicator Driver	0433	No Connection	Spare F. F. Out, 2	0616	0725	Binary Output to Decimal Converter	0628	0726	Binary Output to Decimal Converter
0435	No Connection	Spare F. F. Output	0434	No Connection	Spare F. F. Input	0617	0730	Binary Output to Decimal Converter	0629	0735	Binary Output to Decimal Converter
0436 thru 0441	No Connection	Spare Lamp Driver				0630	0725	Binary Output to Decimal Converter	0631	0731	Binary Output to Decimal Converter
						0632	0720	Binary Output to Decimal Converter	0632	0720	Binary Output to Decimal Converter
						0633	0730	Binary Output to Decimal Converter	0633	0730	Binary Output to Decimal Converter
						0634	0420	Reset Pulse	0634	0420	Reset Pulse
						0635	0413	Readout Counter Input	0635	0413	Readout Counter Input
0501	0501 0401	-6vdc Buss	0508	No Connection		0636	0427	Readout Counter Reset	0636	0427	Readout Counter Reset
0502	0402 0402	Ground Buss	0527	0427	Readout Counter Reset	0637	0735	Binary Output to Decimal Converter	0637	0735	Binary Output to Decimal Converter
0503	0403 0403	6 vdc Buss	0528	No Connection		0638	0725	Binary Output to Decimal Converter	0638	0725	Binary Output to Decimal Converter
0504	0404 0404	-12 vdc Buss	0534	No Connection		0639	0731	Binary Output to Decimal Converter	0639	0731	Binary Output to Decimal Converter
0505	SW-2B, SW-2C	Strobe Zero Output	0535	0219	Input to Strobe Counter	0640	0720	Binary Output to Decimal Converter	0640	0720	Binary Output to Decimal Converter
0506	No Connection		0536	0636 0432	Reset	0641	0730	Binary Output to Decimal Converter	0641	0730	Binary Output to Decimal Converter
0507	0426 0430		0537	No Connection		0642	0420	Reset Pulse	0642	0420	Reset Pulse

TABLE V. WIRING LISTS FOR MASTER CONTROL CHASSIS (Cont'd)

From Board & Pin No.	To Board & Pin No.	Function	From Board & Pin No.	To Board & Pin No.	Function	From Board & Pin No.	To Board & Pin No.	Function	From Board & Pin No.	To Board & Pin No.	Function
0701	0602 0001	Ground Base	0719	0619		0001	0701 0902	Ground Base	0020	Pin 06 DBL-FP*	Count "6"
0702	0601 0002	-6vdc	0720	Pin 06 DBL-FP*	Count "6"	0002	0702 0901	-6vdc Base	0021	Pin 07 DBL-FP*	Count "7"
0703	0603 0003	6vdc Base	0721	Pin 07 DBL-FP*	Count "7"	0003	0703 0903	6vdc Base	0022	Pin 08 DBL-FP*	Count "8"
0704	0604 0004	-12vdc Base	0722	Pin 08 DBL-FP*	Count "8"	0004	0704 0904	-12vdc Base	0023	Pin 09 DBL-FP*	Count "9"
0705	Pin 110 DBL-FP*	Count "9"	0723	Pin 09 DBL-FP*	Count "9"	0005	Pin 110 DBL-FP*	Count "9"	0024	Pin 110 DBL-FP*	Count "10"
0706	0622		0725	0630		0006	0613		0025	0606	
0707	0620		0726	0620		0007	0611		0026	No Connection	
0708	0618		0727	0626		0008	0610		0027	No Connection	
0709	0624		0728	0632		0009	0615		0028	0608	
0710	No Connection		0729	Pin 01 DBL-FP*	Count "1"	0010	Pin 01 DBL-FP*	Count "1"	0029	Pin 01 DBL-FP*	Count "1"
0711	Pin 01 DBL-FP*	Count "1"	0730	0633		0011	0616		0030	0607	
0712	0625		0731	0631		0012	0614		0031	0605	
0713	0623		0732	Pin 02 DBL-FP*	Count "2"	0013	Pin 02 DBL-FP*	Count "2"	0032	Pin 02 DBL-FP*	Count "2"
0714	Pin 02 DBL-FP*	Count "2"	0733	Pin 03 DBL-FP*	Count "3"	0014	No Connection		0033	Pin 03 DBL-FP*	Count "3"
0715	Pin 03 DBL-FP*	Count "3"	0734	Pin 04 DBL-FP*	Count "4"	0015	Pin 03 DBL-FP*	Count "3"	0034	No Connection	
0716	Pin 04 DBL-FP*	Count "4"	0735	0629		0016	Pin 04 DBL-FP*	Count "4"	0041	No Connection	
0717	0621		0736	Pin 05 DBL-FP*	Count "5"	0017	0612				
0718	Pin 05 DBL-FP*	Count "5"	0737	0627		0018	Pin 05 DBL-FP*	Count "5"			
			0738	Pin 06 DBL-FP*	Count "6"	0019	0609				
* Digital Bearing Indicator - Front Panel						* Digital Bearing Indicator - Front Panel					
0739	Pin 07 DBL-FP*	Count "7"	0739	Pin 07 DBL-FP*	Count "7"	0901	0001	-6vdc Base	0931	No Connection	
0740	Pin 08 DBL-FP*	Count "8"	0740	Pin 08 DBL-FP*	Count "8"	0902	0002	Ground Base	0932	Front Panel M	Rm Lamp
0741	Pin 09 DBL-FP*	Count "9"	0741	Pin 09 DBL-FP*	Count "9"	0903	0003	6vdc Base	0933	No Connection	
						0904	0004	-12 vdc Base	0934	0311	
						0905	Front Panel	-15vdc Base	0935 & 0936	No Connection	
						0906 & 0907	No Connection		0937	Front Panel	-15 vdc Base
						0908	Front Panel SW-2A	Slow Clock Output	0938	Rear Panel Power Plug	
						0909 thru 0913	No Connection		0939		-12 vdc Base
						0914	0320		0940		Ground Base
						0915 thru 0923	No Connection		0941		-6vdc Base
						0924	Front Panel SW-2B	-12 vdc Base			
						0925 thru 0927	No Connection				
						0928	Front Panel R1	Slow Clock Rate			
						0929	No Connection				
						0930	Front Panel R2	Slow Clock Rate			
* Digital Bearing Indicator - Front Panel											

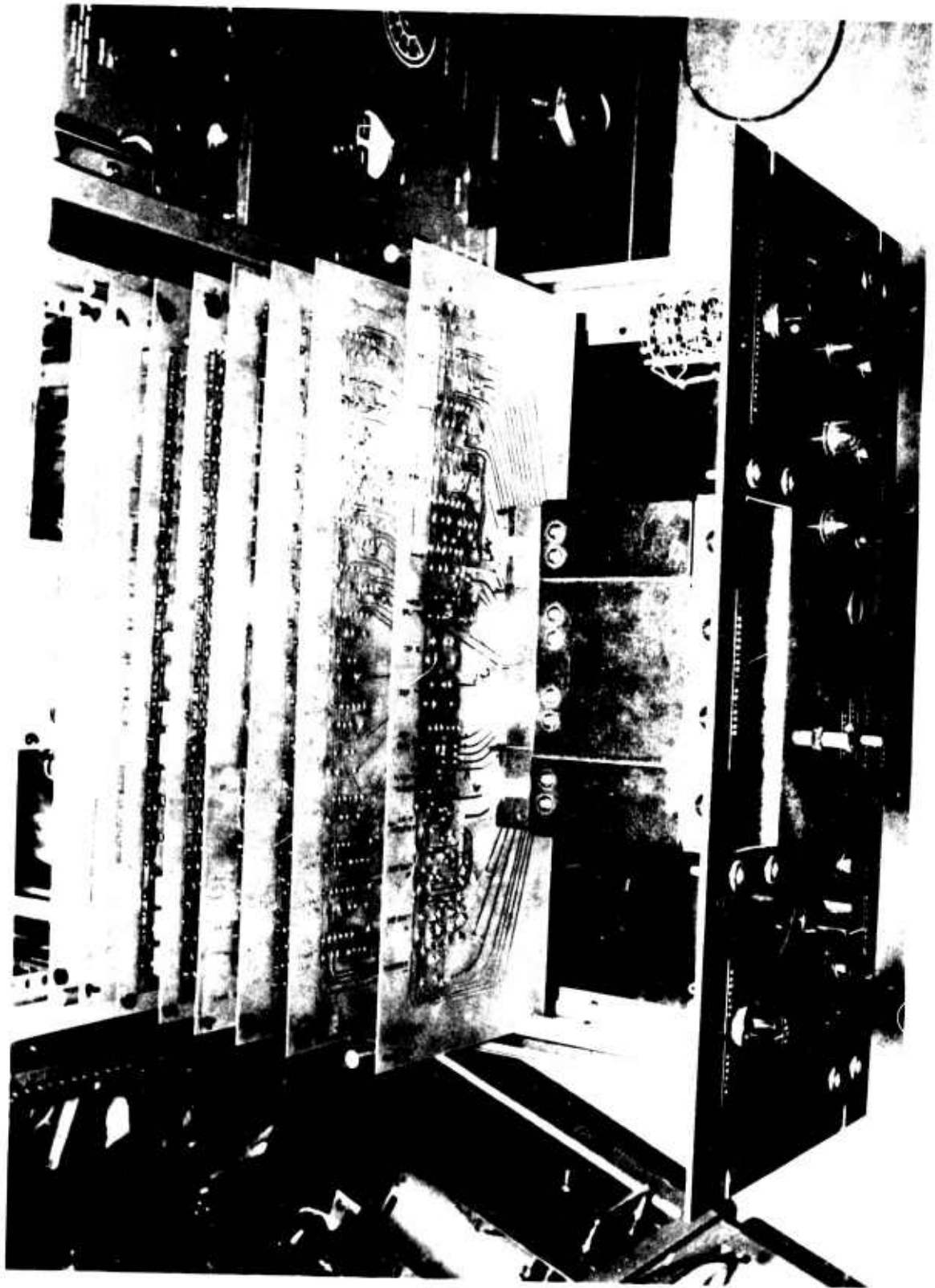

FIGURE 44. COMMUTATOR MASTER CONTROL CHASSIS

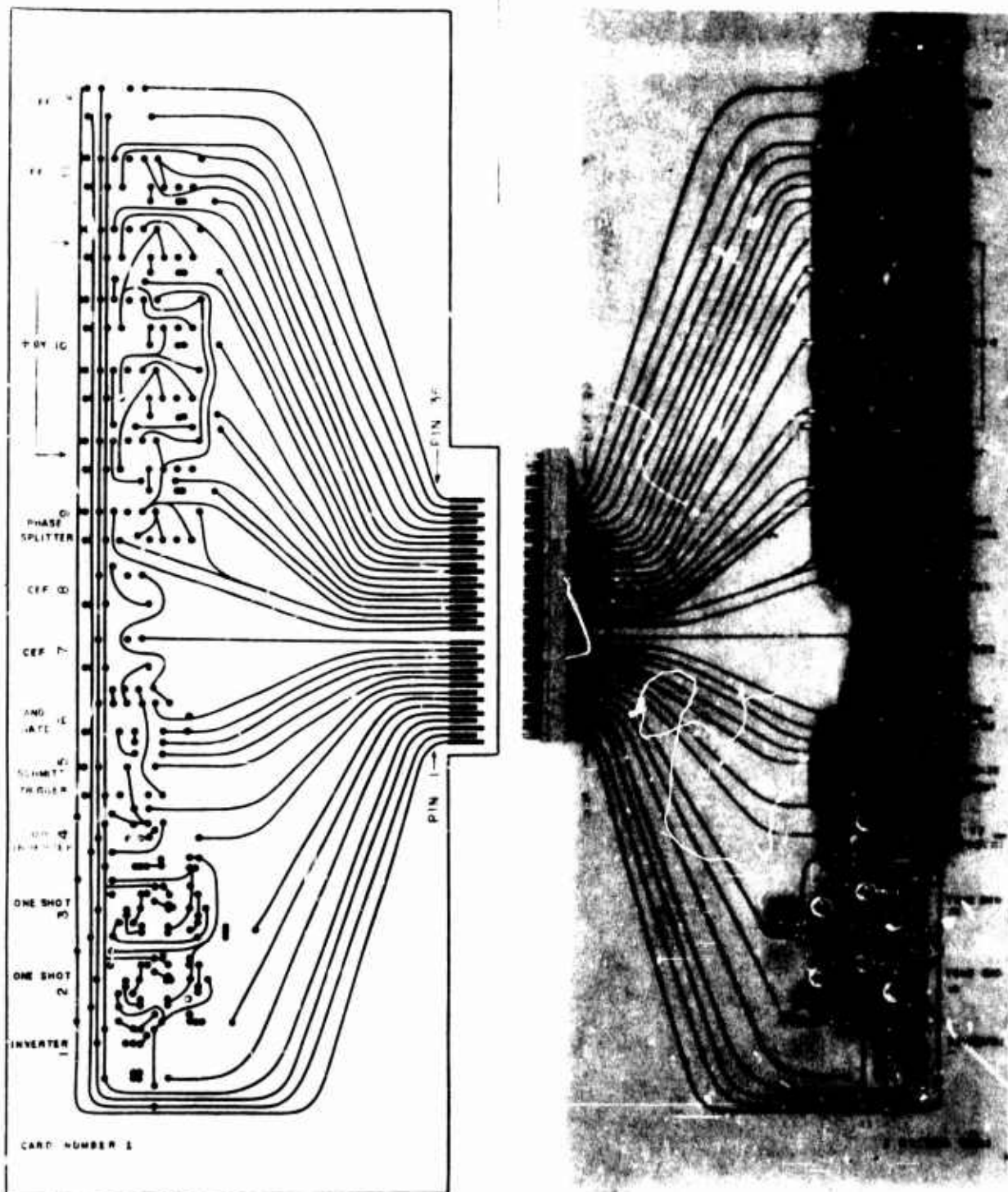

FIGURE 45. LOGIC BOARD NO. 1 - MASTER CONTROL CHASSIS

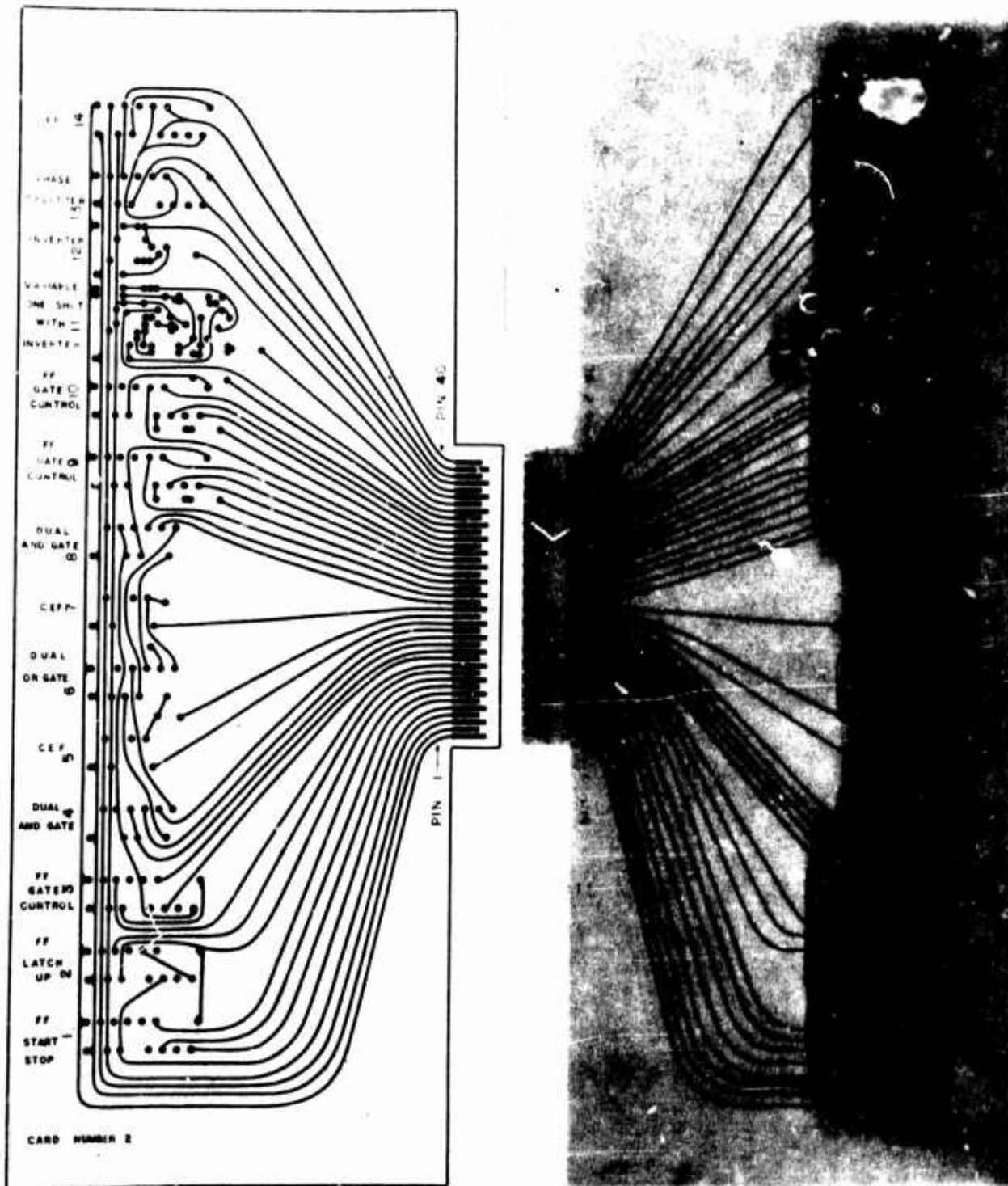

FIGURE 46. LOGIC BOARD NO. 2 - MASTER CONTROL CHASSIS

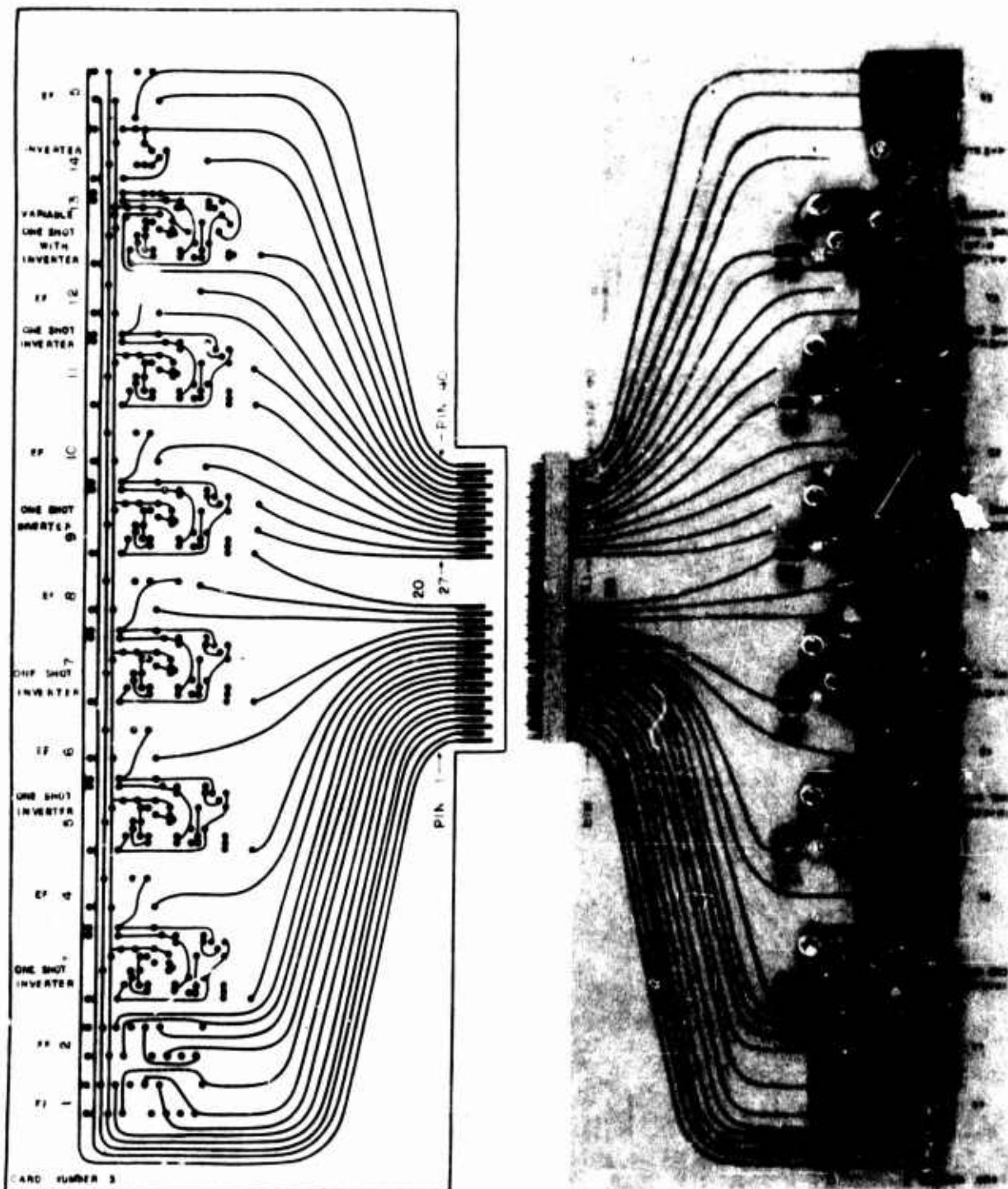

FIGURE 47. LOGIC BOARD NO. 3 - MASTER CONTROL CHASSIS

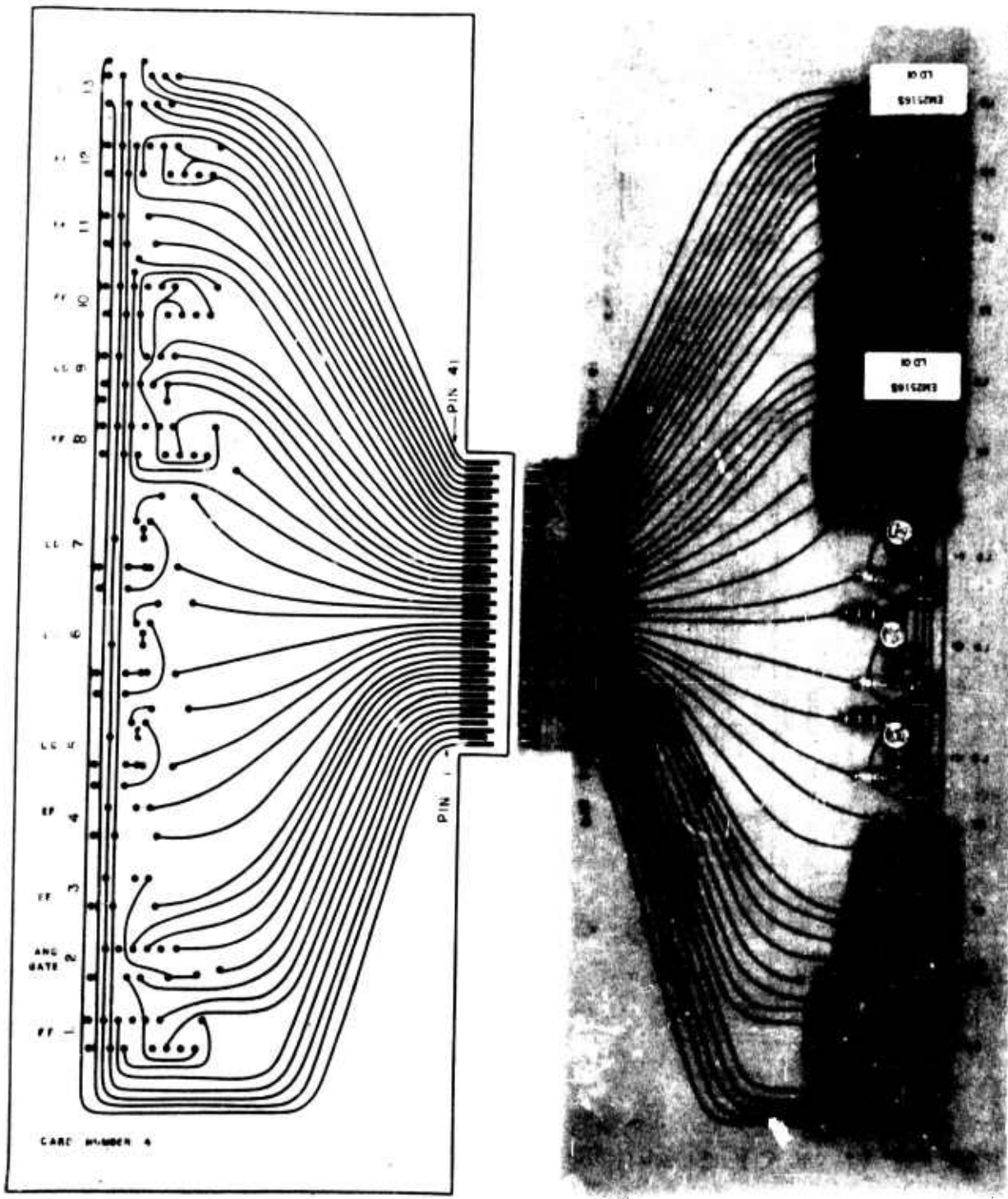

FIGURE 48. LOGIC BOARD NO. 4 - MASTER CONTROL CHASSIS

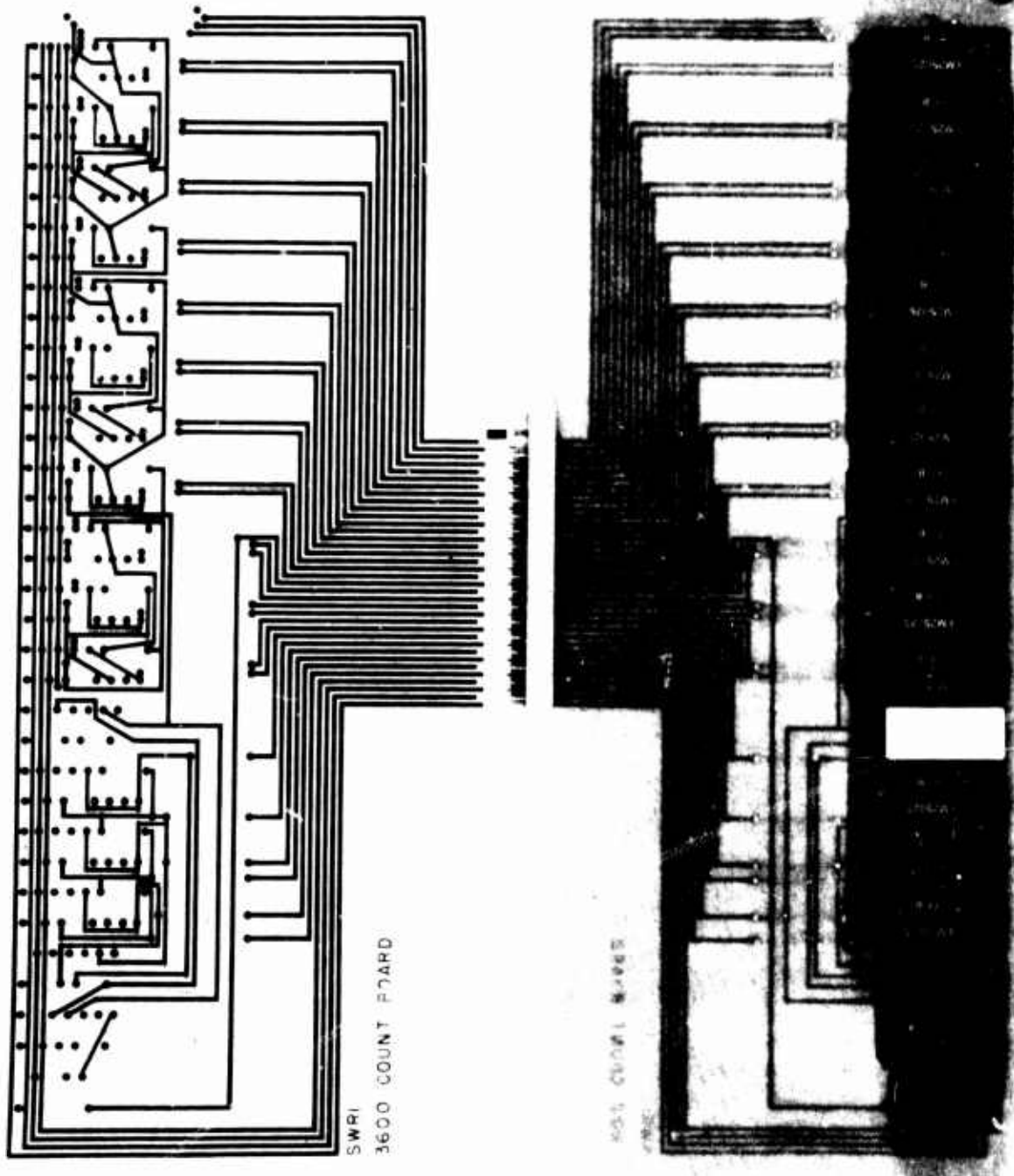

FIGURE 49. LOGIC BOARD NO. 5 - 0-3599 STROBE POSITION COUNTER

SWRI
O-9 C-9 BDC

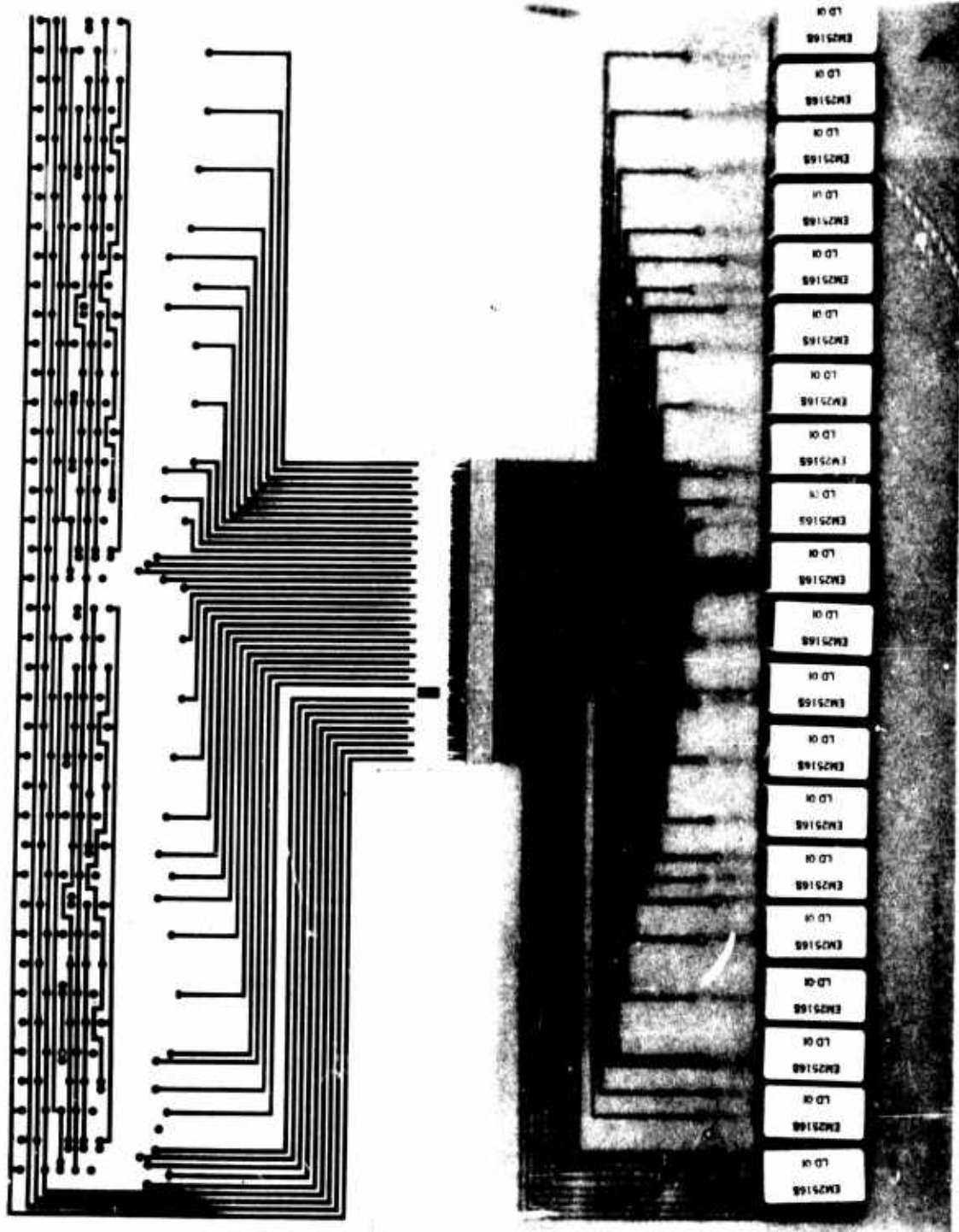

FIGURE 50. LOGIC BOARD NO. 7 - BINARY TO DECIMAL
DECODER AND LAMP DRIVER

SWRI
0-9 0-3 BDC

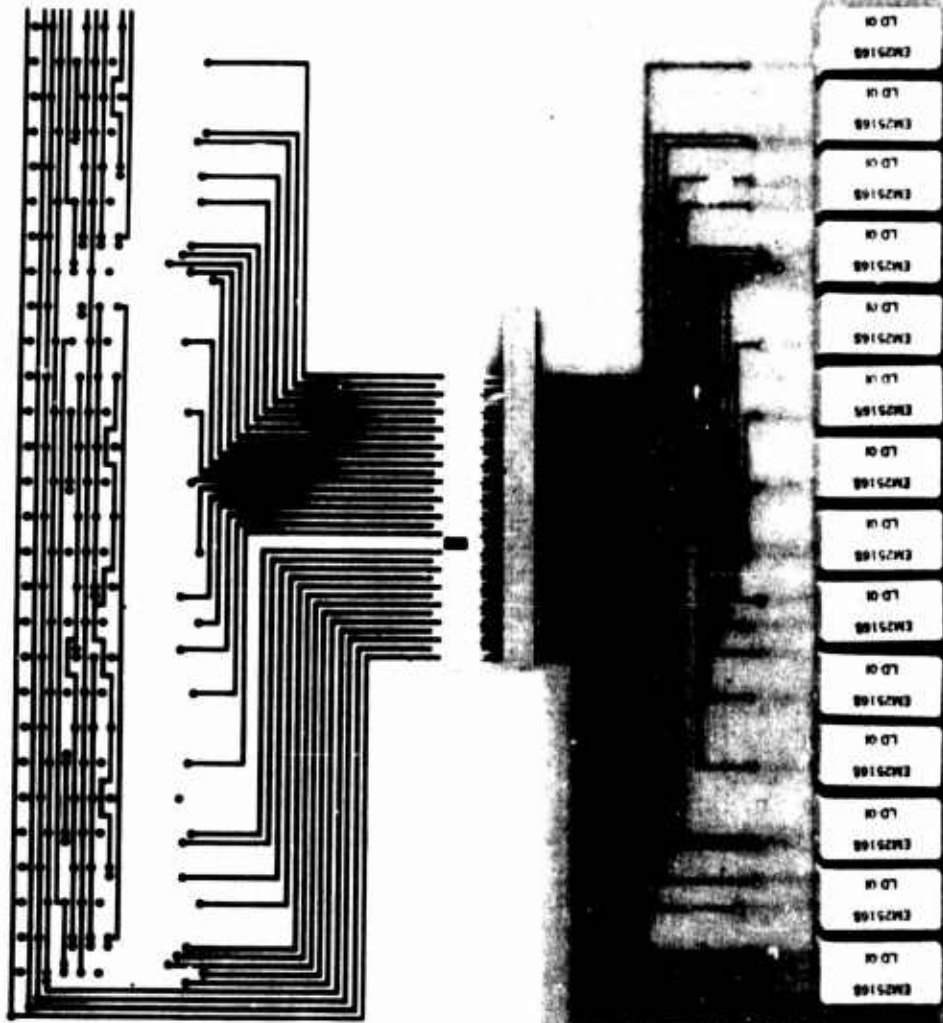

FIGURE 51. LOGIC BOARD NO. 8 - BINARY TO DECIMAL
DECODER AND LAMP DRIVER

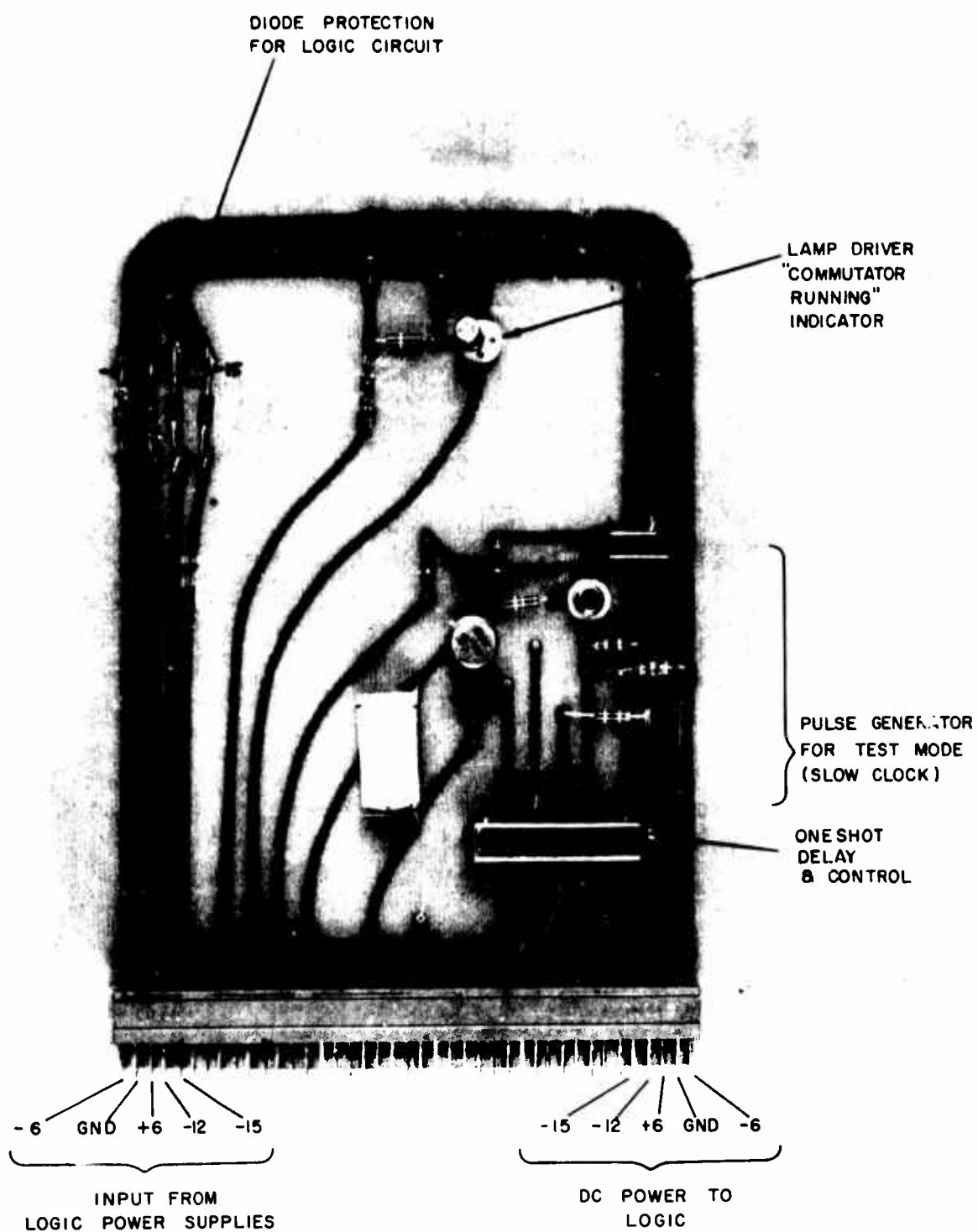

FIGURE 52. LOGIC BOARD NO. 9 - MASTER CONTROL CHASSIS

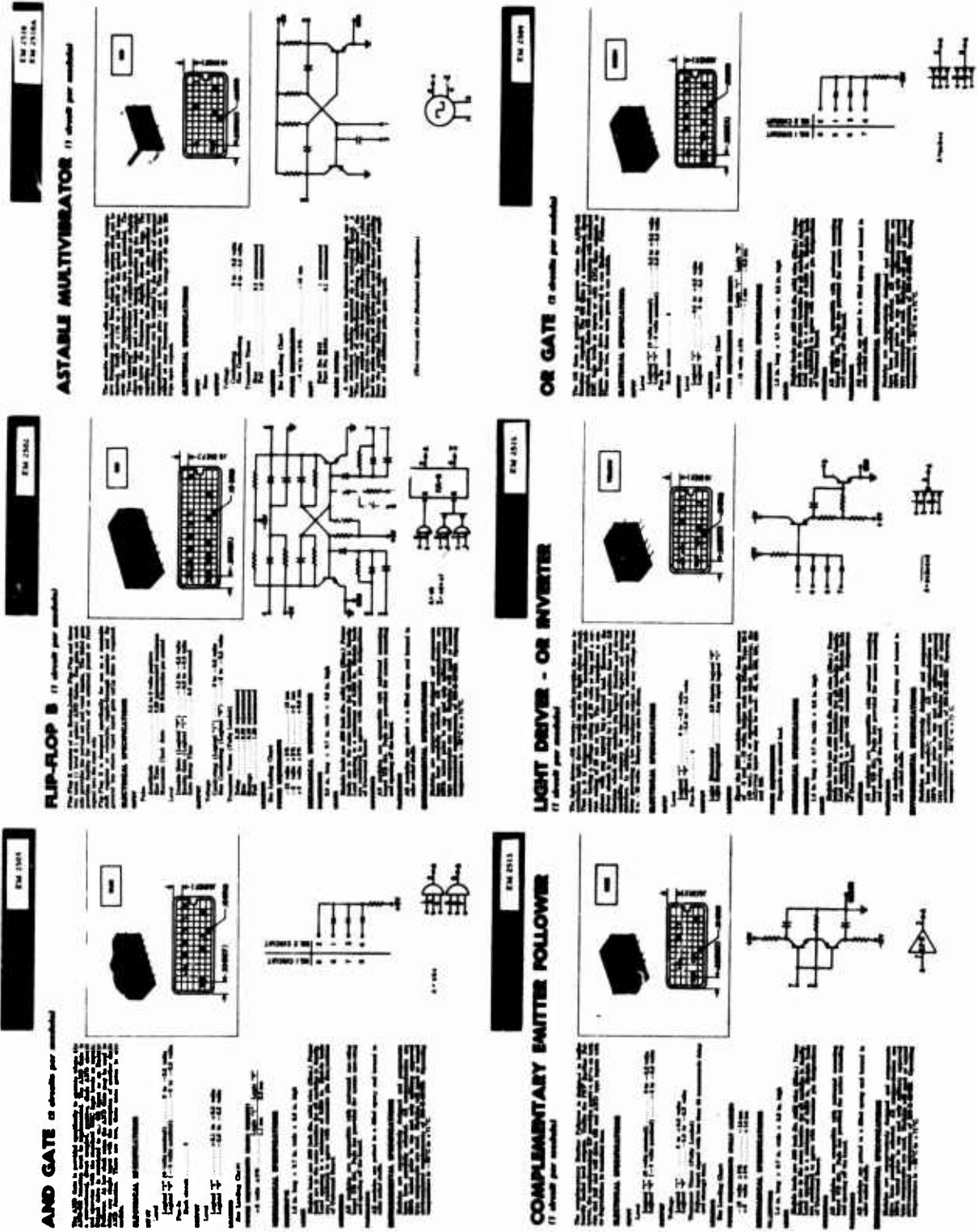

FIGURE 53. WELDED MODULE SPECIFICATIONS

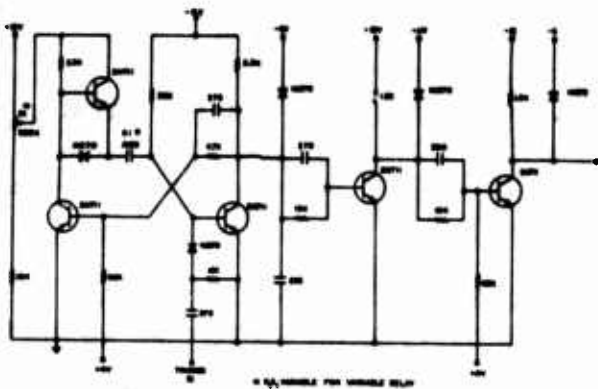

FIGURE 54A VARIABLE DELAY ONE SHOT FOR SLEW RATE AND MULTIPLIER CIRCUITS

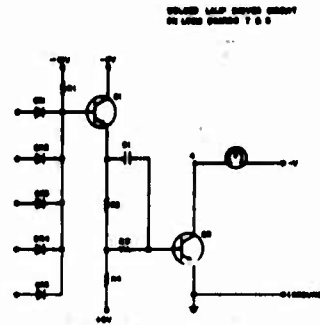

FIGURE 54B BINARY TO DECIMAL DECODER AND AMP DRIVER CIRCUIT

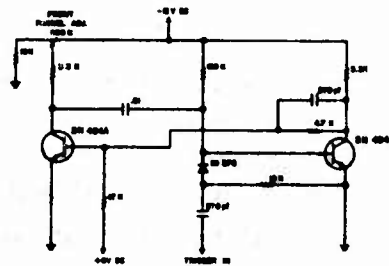

FIGURE 54C STROBE DELAY ONE SHOT

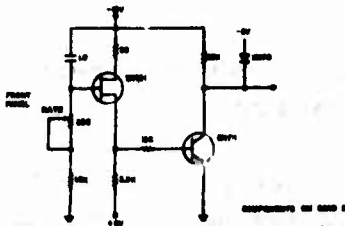

FIGURE 54D VARIABLE FREQUENCY PULSE GENERATOR FOR "TEST" MODE

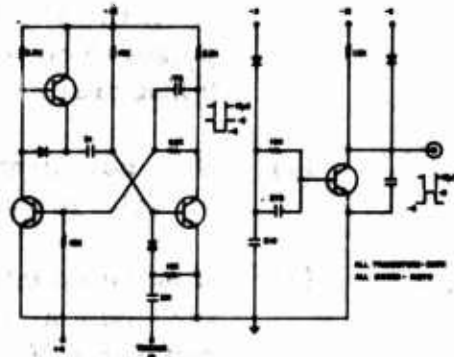

FIGURE 54E PULSE SHAPER - 10 MICROSECOND ONE SHOT

FIGURE 54. SCHEMATICS OF SPECIAL LOGIC CIRCUITS

To check commutator set in a beam described in Section 7:

- (1) Press START button, and observe if the RUN indicator flashes at a 5-cycle rate. If CRT pattern is steady, no further test need be made; however, if commutator runs but pattern rotates, go to Step (6) below.
- (2) If commutator does not run, switch SIZE (Item 11, Figure 16) to TEST. If full-scale circle is observed on CRT, then shaft encoder is rotating.
- (3) If spot only (no circle), check goniometer flywheel to visually determine if shaft is rotating.
- (4) If no rotation, check goniometer chassis (TM-11-688).
- (5) If shaft is rotating and no circle, check IP 137 (TM-11-688).
- (6) If CRT circle is obtained, use a BNC tee connector into SYNC (25) and OPTICAL GEN TRIGGER (26) outputs and establish that the proper counts, ten pulses per second and 36 kHz, are being obtained (by calibrated oscilloscope or frequency counter).
- (7) If counts are correct, go to Step (9); if improper counts, check voltages to electronics module (Figure 18), and direct outputs from the shaft encoder assembly (approximately 50-millivolt pulses from CW and CCW leads with 900 pulses per revolution, 9 kHz from each output).
- (8) If no output at encoder (input to electronics module), recheck all voltages and replace encoder if necessary.
- (9) If pulse counts of Step (6) are correct, trace pulse circuits through commutator by reference to Figures 38, 55, 56 and 57, and Table V. Isolate the defective stage(s) and repair or replace as necessary. The primary paths for deriving the ring counter trigger and sync pulses are shown by the heavy lines on Figure 38 (all other circuits are used for bearing readout and cursor generation and have no direct influence upon the operation of the commutator main task - to sample the antenna array in a programmed manner). Begin troubleshooting at the 1800-OUTPUT TO RING COUNTER jack on the back panel. Pulse count should be 1800 pulses/second. Refer to Figures 56 and 57 for CRT traces. If incorrect count, check decade

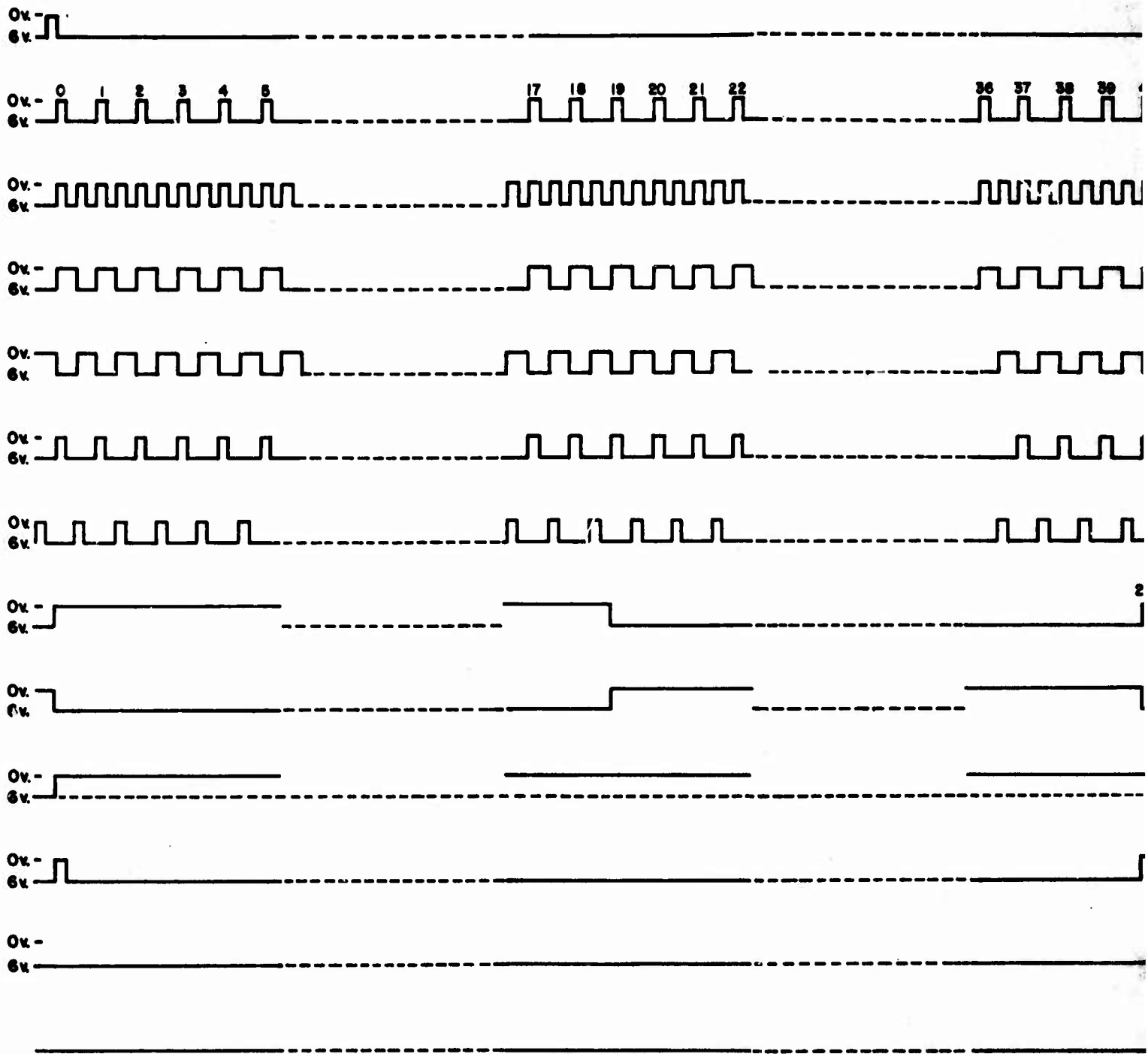
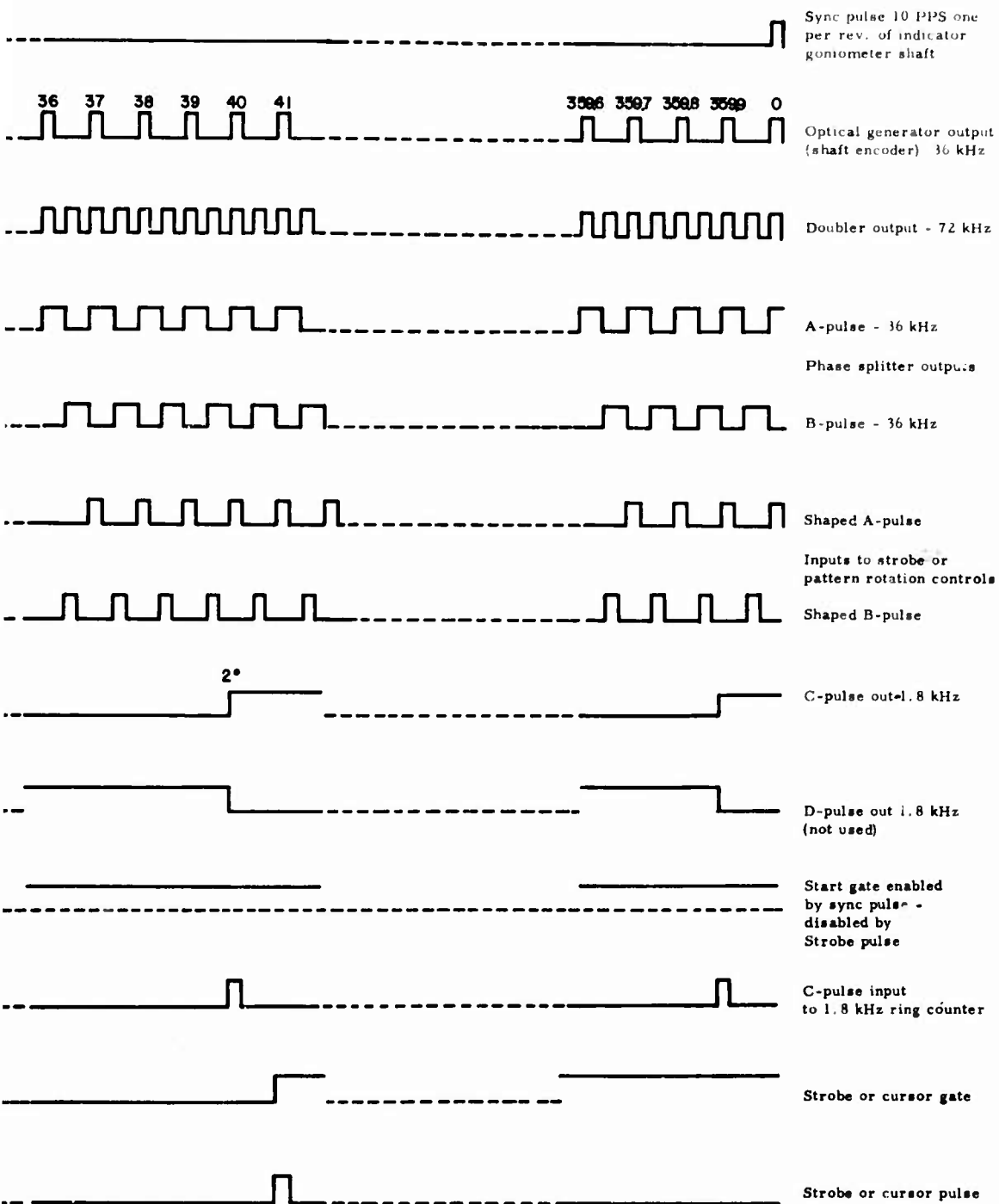

FIGURE 55. COMMUTATOR TIMING



NOTES:

1. C-Pulse clocks commutator when in strobe slew or fixed pattern position.
2. The two counters count 0° to 359.9. Counter No. 1 (Strobe Position Counter) generates the Strobe pulse (electronic cursor) while Counter No. 2 (Bearing Readout Counter) provides a digital readout (in decimal degrees azimuth) of the location of the strobe pulse in Counter No. 1 relative to a reference position (sync pulse at 0.0°).
3. The bearing readout counter will count for one revolution (maximum) of the optical generator (or indicator goniometer) shaft. The counter input gate is enabled by the strobe pulse and disabled by the sync pulse for pattern rotation. Conversely the sync pulse enables and strobe pulse disables the gate for strobe rotation (fixed pattern display).
4. The digital readout of Counter No. 2 is held for two revolutions then is reset in the fourth revolution i. e., in four shaft revolutions the count is made, displayed visually and reset to zero. The readout is balanced during the reset cycle (causing the readout to blink). Counter No. 1 is not reset (after the sync pulse operates the start gate to the ring counter) and continues to count sequential pulses that enter the 180 stage ring counter.
5. Strobe or cursor gate reads 2.1° in example.

COMMUTATOR TIMING DIAGRAM

2



1
Upper Trace - 36 kHz Optical Generator
Rear Panel BNC
Lower Trace - 36 kHz Delay One Shot
Output Pin 0338
Sweep: Horizontal - 10 μ sec/cm
Vertical - 5 volts/cm
Trigger: External from "Scope Trigger"
BNC Rear Panel

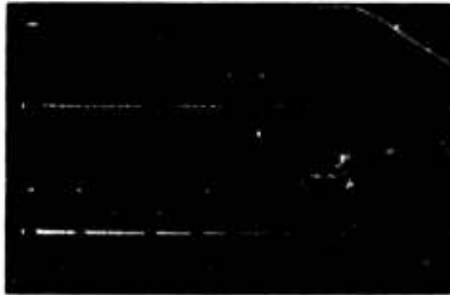

2
Upper Trace - 36 kHz Optical Generator
Rear Panel BNC
Lower Trace - 72 kHz Input to Phase
Splitter Pin 0138
Sweep: Horizontal - 10 μ sec/cm
Vertical - 5 volts/cm
Trigger: External from "Scope Trigger"
BNC Rear Panel



3
Upper Trace - 72 kHz Trigger to Phase
Splitter Pin 0138
Lower Trace - "A" Pulse One Shot
Pin 0314
Sweep: Horizontal - 10 μ sec/cm
Vertical - 5 volts/cm
Trigger: External from "Scope Trigger"
BNC Rear Panel



4
Upper Trace - 72 kHz Trigger to Phase
Splitter Pin 0138
Lower Trace - "B" Pulse One Shot
Pin 0316
Sweep: Horizontal - 10 μ sec/cm
Vertical - 5 volts/cm
Trigger: External from "Scope Trigger"
BNC Rear Panel



5
Upper Trace - 36 kHz Optical Generator
Rear Panel BNC
Lower Trace - Phase Splitter "A" Pulse
Pin 0118
Sweep: Horizontal - 10 μ sec/cm
Vertical - 5 volts/cm
Trigger: External from "Scope Trigger"
BNC Rear Panel

FIGURE 56. OSCILLOSCOPE TRACES OF PULSE TEST POINTS



6
 Upper Trace - One Shot "B" Pulse
 Pin 0316
 Lower Trace - "C" Pulse Output
 Pin 0132
 Sweep: Horizontal - 10 $\mu\text{sec}/\text{cm}$
 Vertical - 5 volts/cm
 Trigger: External from "Scope Trigger"
 BNC Rear Panel

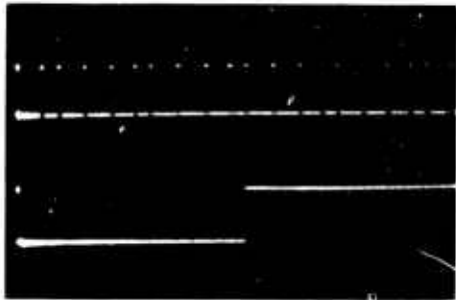

7
 Upper Trace - One Shot "B" Pulse
 Pin 0316
 Lower Trace - "C" Pulse Output
 Pin 0132
 Sweep: Horizontal - 50 $\mu\text{sec}/\text{cm}$
 Vertical - 5 volts/cm
 Trigger: External from "Scope Trigger"
 BNC Rear Panel

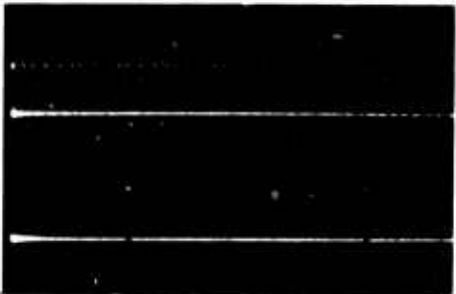

8
 Upper Trace - One Shot "B" Pulse
 Pin 0316
 Lower Trace - One Shot "C" Pulse
 Pin 0333
 Sweep: Horizontal - 100 $\mu\text{sec}/\text{cm}$
 Vertical - 5 volt/cm
 Trigger: External from "Scope Trigger"
 BNC Rear Panel

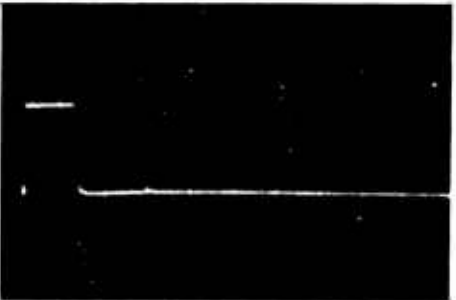

9
 Strobe Output Rear Panel BNC
 Sweep: Horizontal - 10 $\mu\text{sec}/\text{cm}$
 Vertical - 5 volts/cm
 Trigger: Internal



10
 Optical Generator Zero Sync Input
 Rear Panel BNC or Pin 0320
 Sweep: Horizontal - 5 $\mu\text{sec}/\text{cm}$
 Vertical - 5 volts/cm
 Trigger: Internal

FIGURE 57. OSCILLOSCOPE TRACES OF PULSE TEST POINTS

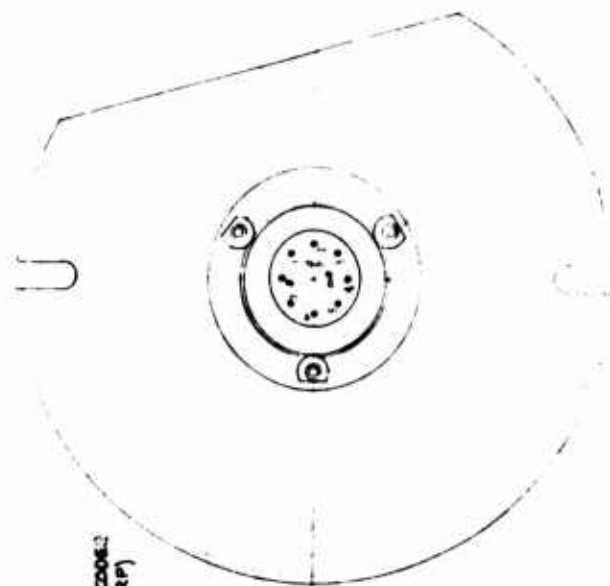

— DRIVE HOUSING

OPTICAL SHAFT ENCODER
(WAYNE GEORGE CORP)
R136001A

— OLDHAM
COUPLING

— DRIVE SHAFT

TO GONIOMETER
DRIVE HOUSING
MX-1170/GRD

- PIN 1 - CHANNEL 1 - INPUT
- PIN 2 - CHANNEL 2 - INPUT
- PIN 3 - CHANNEL 3 - INPUT
- PIN 4 - COMMON
- PIN 5 - +5VDC
- PIN 6 - COMMON 5VDC
- PIN 7 - CASE GROUND
- PIN 8 - +5VDC
- PIN 9 - NO VDC

FIGURE 58

NOTE:
JAWS OF COUPLING MUST BE
ALIGNED AT 90° AS SHOWN
DURING ASSEMBLY

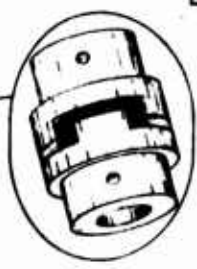

MOUNT AND DRIVE ASSEMBLY FOR OPTICAL SHAFT ENCODER		DRAWING NUMBER	
SOUTHWEST RESEARCH INSTITUTE		B-1360-00-01	
SAN ANTONIO, TEXAS			
DES. BY	INTL.	TOLERANCES UNLESS NOTED	
CHK. BY	NO. DES.	GENERAL PRACTICE APPL.	
APP. BY	SCALE FULL	DATE 12/7/67	

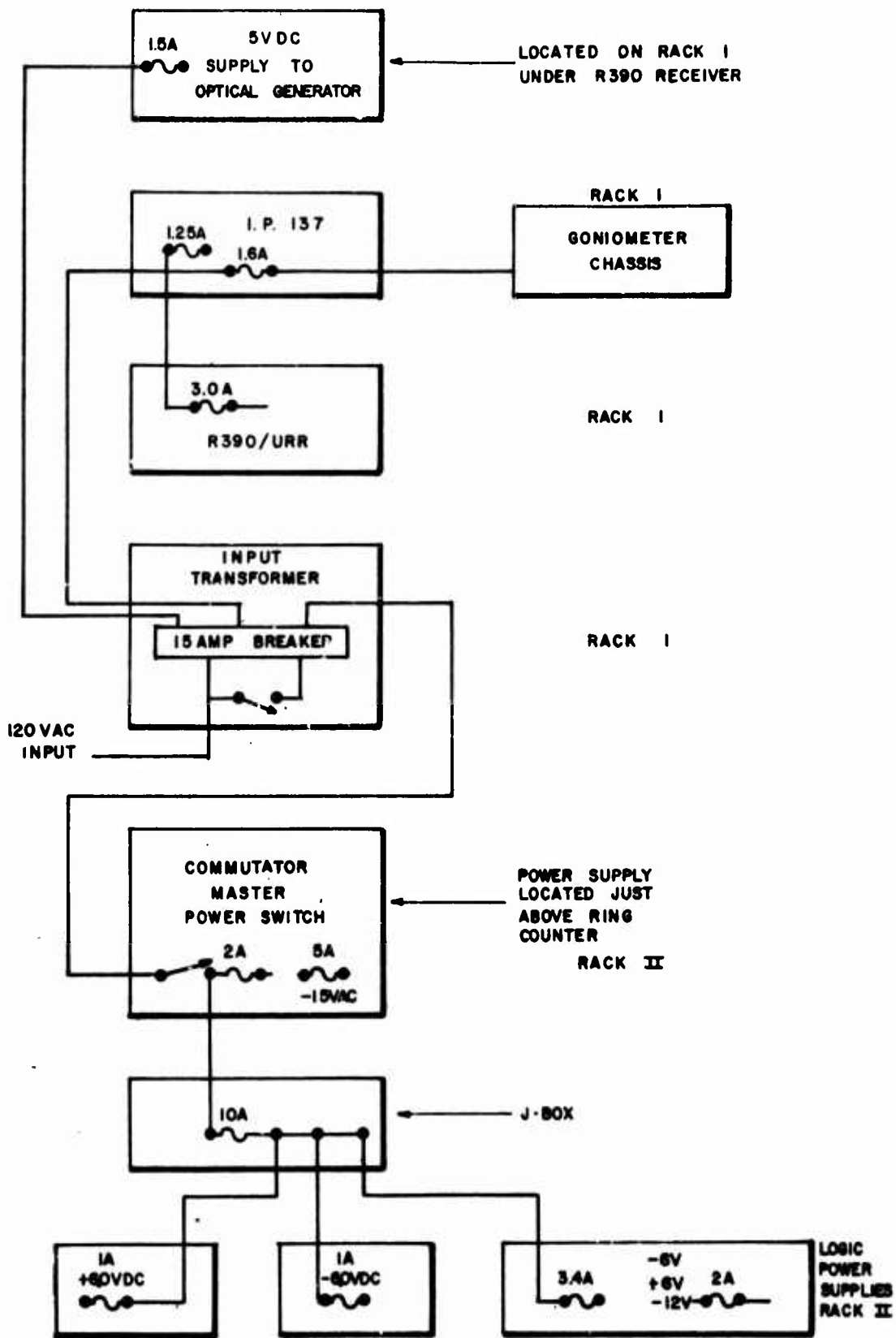

FIGURE 59. FUSE LOCATIONS AND AC POWER CONNECTIONS

divider; if no pulse output, check sync circuits and hold-off gate.

- (10) If trigger output to ring counter is correct, check trigger buss on ring counter chassis (pin 41, each connector) and the emitter follower outputs on Boards Nos. 1, 3, 5, 7, 9 and 11.
- (11) If trigger pulses are present at each emitter follower output and commutator does not run, switch CLOCK INPUT switch (13) to TEST. The switch to TEST must be done after the commutator hold-off circuits have been enabled by the START sequence. Do not push STOP button (14) when in the TEST position. Use only the RESET function. If it is desired to stop during test commutation, place CLOCK INPUT (13) in OFF position.
- (12) Set 0° antenna switch (17) ON and with CLOCK INPUT in TEST, adjust pulse rate of test clock by adjustment of TEST RATE control. Rate should be slow enough to observe the one bit being sequentially stepped through the ring counter. A defective stage can be determined by noting the antenna position on the beam forming panel where the ON lamp fails to pass, i. e., count is dropped.
- (13) Experience has shown that the most probable cause is faulty contact between the printed circuit board and its chassis connector; therefore, a slight scrubbing motion between the board and connection may be all that is necessary. If trouble persists at an identifiable stage, check voltage, wiring and flip-flop unit. Repair or replace as required.
- (14) If commutator runs but no RF signal, check cable connections to R390 and azimuth indicator chassis. Check power supply voltages to RF drawers. Insert test signal oscillator at: (1) R390 INPUT, then (2) test jack for 0° antenna. Special test cables for the Burndy multiconnectors are provided.

9.5 System Performance Tests

Optimum performance from the Beverage DF system can be obtained when all components are properly adjusted and aligned. Aside from the calibration program previously described, other tests that can be easily performed are: receiver sensitivity and noise figure, and array sensitivity and gain. Typical sensitivity and noise figures as a function of frequency for the

R390 receiver furnished are plotted in Figure 60; array sensitivity as a function of frequency and antenna elements used to form the array beam is plotted in Figure 61. A typical plot of array gain as a function of antennas forming the beam is plotted in Figure 62 for 10 MHz.

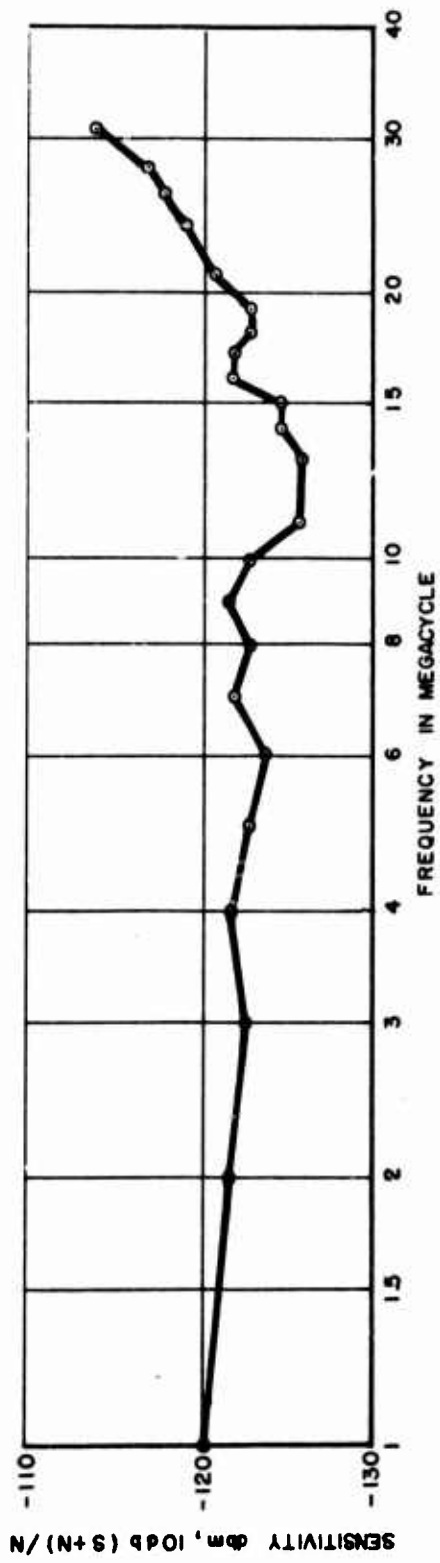

R390 Serial No. 2294, Bandwidth - 2 kHz

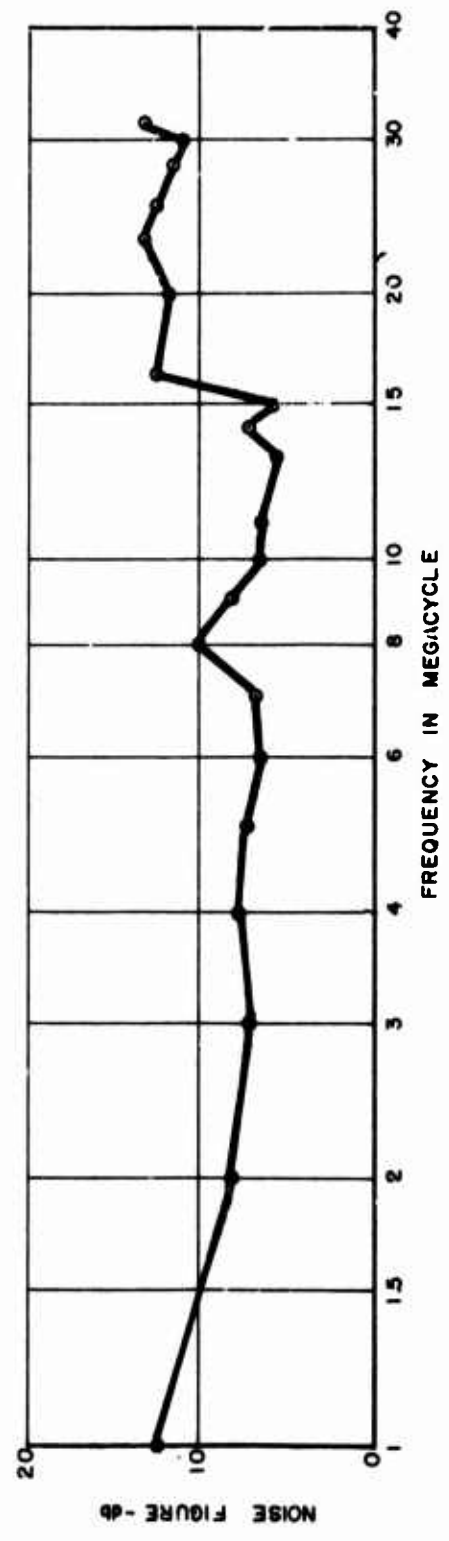
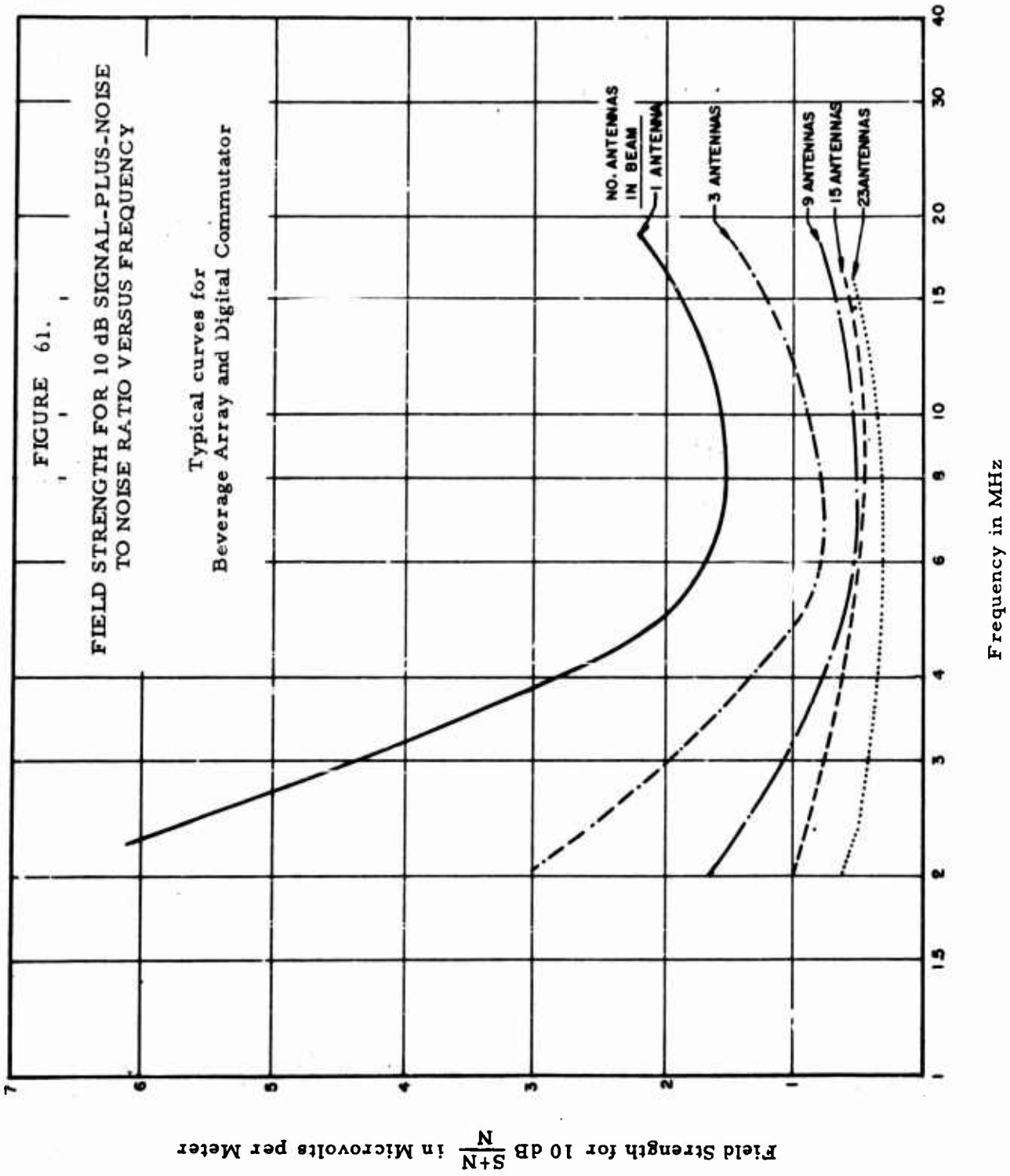

FIGURE 60. SENSITIVITY AND NOISE FIGURE MEASUREMENTS FOR R390/URR



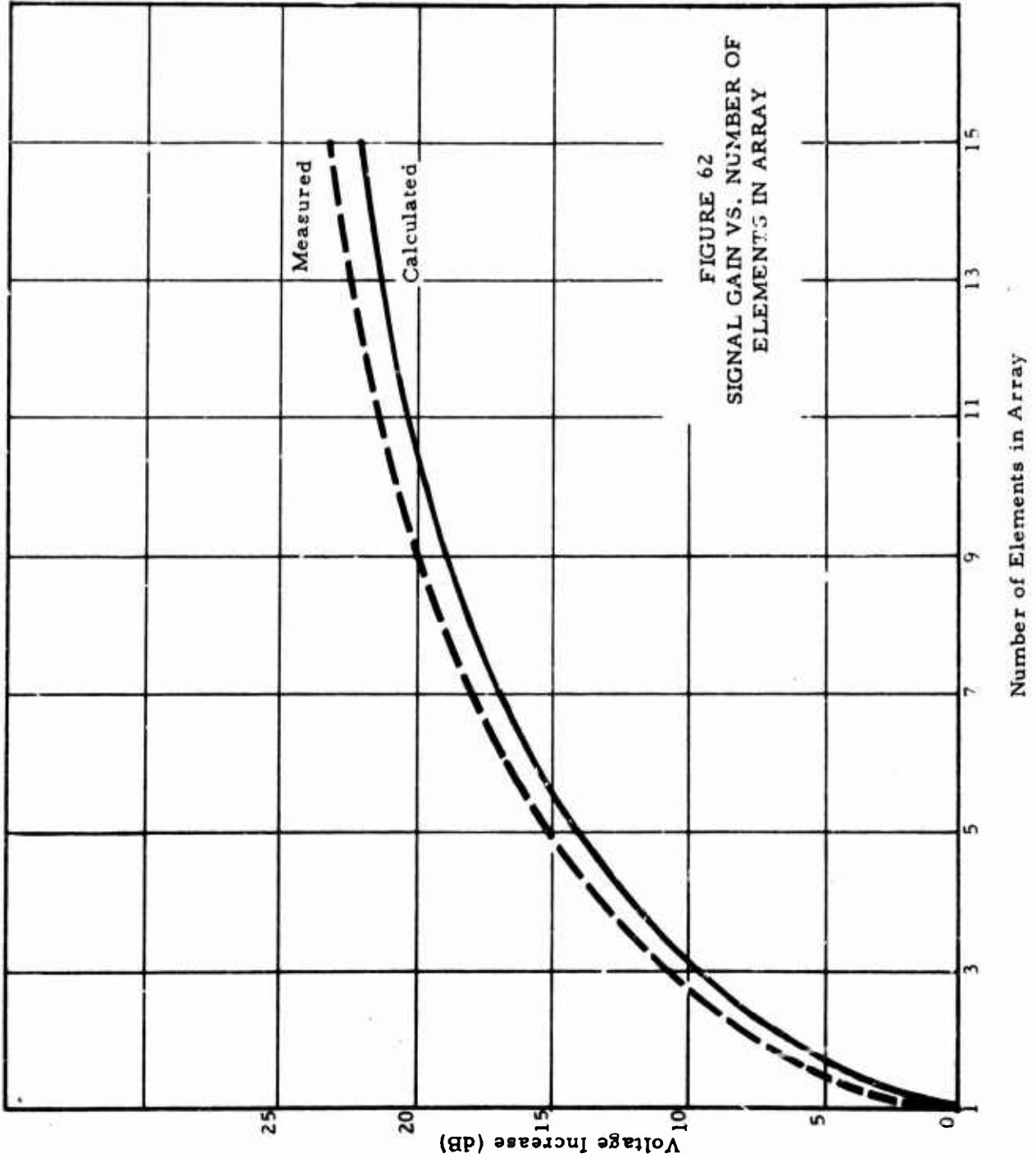

FIGURE 62
SIGNAL GAIN VS. NUMBER OF
ELEMENTS IN ARRAY

10. MISCELLANEOUS

10.1 Shipping Lists

A listing of the boxes and contents for the Beverage DF system is given in Table VI. All shipping crates have been designed for reuse; therefore, it is important that they be opened on the side marked OPEN HERE. Representative crates are shown in Figure 63.

CAUTION: Use extreme care in handling and uncrating the electronic equipment; refer to the special handling instructions included with the packing list on the outside of each crate.

10.2 Antenna Components for One Antenna Circuit

A complete listing and identification of all parts for one antenna assembly up to the RF input to the commutator is given in Table I.

10.3 Spare Parts

An itemized list of all spare parts shipped with the system is given in Table VII.

TABLE VI. SHIPPING LIST FOR BEVERAGE
ANTENNA HARDWARE

SHIPPING LIST			
BOX NO.	CONTENTS	WEIGHT	SIZE
1	Antenna Assemblies 0° thru 16°	230	33-1/4" x 33-1/4" x 13-7/8"
2	Antenna Assemblies 18° thru 34°	230	33-1/4" x 33-1/4" x 13-7/8"
3	Antenna Assemblies 36° thru 52°	230	33-1/4" x 33-1/4" x 13-7/8"
4	Antenna Assemblies 54° thru 70°	230	33-1/4" x 33-1/4" x 13-7/8"
5	Antenna Assemblies 72° thru 88°	230	33-1/4" x 33-1/4" x 13-7/8"
6	Antenna Assemblies 90° thru 106°	230	33-1/4" x 33-1/4" x 13-7/8"
7	Antenna Assemblies 108° thru 124°	230	33-1/4" x 33-1/4" x 13-7/8"
8	Antenna Assemblies 126° thru 142°	230	33-1/4" x 33-1/4" x 13-7/8"
9	Antenna Assemblies 144° thru 160°	230	33-1/4" x 33-1/4" x 13-7/8"
10	Antenna Assemblies 162° thru 178°	230	33-1/4" x 33-1/4" x 13-7/8"
11	Antenna Assemblies 180° thru 196°	230	33-1/4" x 33-1/4" x 13-7/8"
12	Antenna Assemblies 198° thru 214°	230	33-1/4" x 33-1/4" x 13-7/8"
13	Antenna Assemblies 216° thru 232°	230	33-1/4" x 33-1/4" x 13-7/8"
14	Antenna Assemblies 234° thru 250°	230	33-1/4" x 33-1/4" x 13-7/8"
15	Antenna Assemblies 252° thru 268°	230	33-1/4" x 33-1/4" x 13-7/8"
16	Antenna Assemblies 270° thru 286°	230	33-1/4" x 33-1/4" x 13-7/8"
17	Antenna Assemblies 288° thru 304°	230	33-1/4" x 33-1/4" x 13-7/8"
18	Antenna Assemblies 306° thru 322°	230	33-1/4" x 33-1/4" x 13-7/8"
19	Antenna Assemblies 324° thru 340°	230	33-1/4" x 33-1/4" x 13-7/8"
20	Antenna Assemblies 342° thru 358°	230	33-1/4" x 33-1/4" x 13-7/8"
21	400 Antenna Stakes	210	39" x 17-3/8" x 19"
22	400 Antenna Stakes	210	39" x 17-3/8" x 19"
23	400 Ground Clamps	145	23-8/8" x 8-7/8" x 11-1/2"
24	100 Ground Rods	220	38" x 6" x 7-1/2"
25	100 Ground Rods	220	38" x 6" x 8-1/2"
26	100 Ground Rods	220	38" x 6" x 8-1/2"
27	100 Ground Rods	220	38" x 6" x 8-1/2"
28	200 Antenna Stakes 2 40 Sledge Hammers		39" x 17-3/8" x 19"
29	3 Spare Antenna Assemblies		33-1/4" x 33-1/4" x 13-7/8"
30	Equipment Cabinet I*		81-1/8" x 33-11/16" x 37-3/4"
31	Equipment Cabinet II		81-1/8" x 36-5/16" x 33-3/25"
32	High Pass Filter Assembly		
33	Chord Locator		
*	Commutator Spare Parts Packed in Drawer of Cabinet		

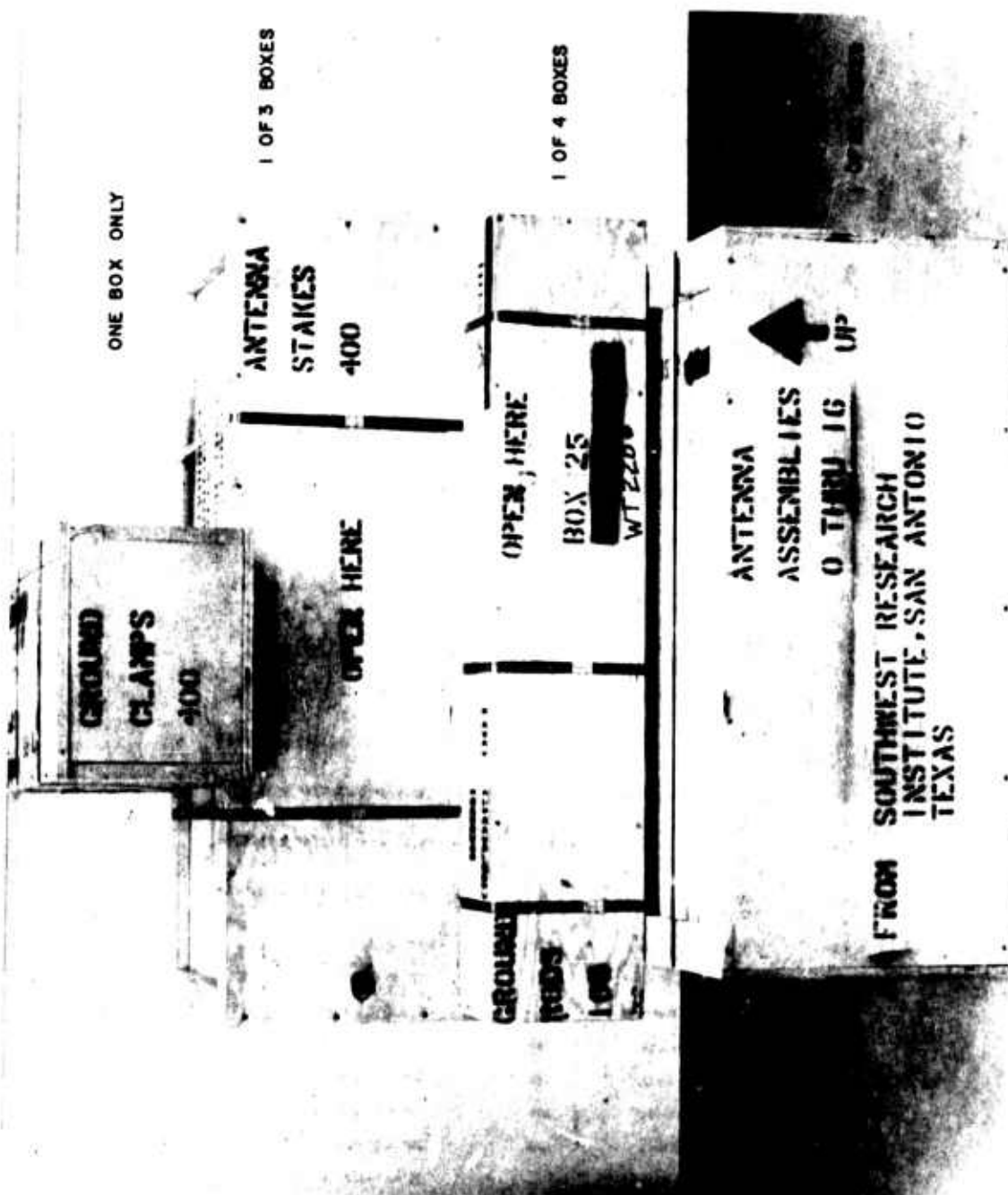

FIGURE 63. ANTENNA HARDWARE SHIPPING CRATES

TABLE VII. SPARE PARTS FOR BEVERAGE DF SYSTEM

<u>Description</u>	<u>Quantity</u>
<u>Antenna Parts</u>	
Antenna assemblies on reel	3
Ground rods	40
Ground clamps	40
Antenna stakes	100
Transformer assemblies	6
Resistor assemblies	6
High pass filters	4
Commutator to filter cables	10
<u>Commutator Parts</u>	
Welded Module - EMC	
B flip-flop No. 2502S	5
Lamp driver No. 2516S	5
Dual and gate No. 2503	2
Dual OR gate No. 2509	2
Schmidt trigger No. 2505	2
RF card (two gates per card)	4
2N711B transistor	25
1N270 diode	25
CTS potentiometer C140PC101A 100 ohms	2
CTS potentiometer C140PC103A 10k	2
Capacitor, 0.005 med, 50 VDCW	10
Capacitor, 0.05 med, 10 VDCW	10
Resistor, 1/40W, 10 percent, 18,000 ohm	10
Resistor, 1/4-W, 10 percent, 22,000 ohm	10
Resistor, 1/4-W, 10 percent, 56,000 ohm	10
Transistor, 2N404A	10

11. GENERAL INSTRUCTIONS AND PLANNING FOR BEVERAGE SYSTEM

The following notes supplement the more detailed instructions of Sections 6 and 7. The purpose is to aid the establishment of a plan of execution for the installation of and operation of the Beverage DF system and to provide planning sheets for the organization of work and work assignments.

11.1 Basic Instructions

- (1) Select and inspect site.
- (2) Determine maximum allowable array diameter for the site selected. (Section 6.3.1 of instruction manual).
- (3) Prepare site (such as mowing, removal of brush, trees, rock, etc.) to the extent desired (Section 6.3.1).
- (4) Using the grid sheets furnished, lay out array specifying element locations (both in azimuth and distance from array center) (Section 6.4).
- (5) Set up work sheet of tasks to be done and assignments in the following order:
 - (a) Locate the reference radial at 0° or True North (Section 6.6).
 - (b) Measure the specified distance from the array center to locate the feedpoint end of the reference antenna element.
 - (c) Locate and drive the ground rod for the paint selected in (b).
 - (d) Locate ground rod locations at the element feedpoint for the remaining antennas in the array (according to the location method selected, Section 6.7).
 - (e) Install antennas and feedcables - make antenna assignments in a sequential order; use Table VIII.
 - (f) Install electronic equipment filters and filter to commutator cables.

- (g) Connect AC power to system.
- (h) Operate system as outlined in Operating Instructions (Section 7).
- (i) Check out and calibrate system (Section 8).
- (j) Begin DF Operation.

11.2 Operating Instructions

The following instructions are furnished with the DF instrumentation:

- (1) Set up equipments as described in the Instruction Manual.
- (2) Turn all individual power supply switches ON.
- (3) Turn GONIOMETER DRIVE, MAIN POWER and INDICATOR POWER switches ON (all located on IP 137 Indicator).
- (4) Turn MASTER AC POWER switch ON to 120VAC position (Located below R390).
- (5) Allow 5 to 10-minute warmup
- (6) Set R390 RF GAIN to minimum (counterclockwise).
- (7) Adjust SPOT SIZE controls for minimum spot size on CRT (Controls interact).
- (8) Turn COMMUTATOR MASTER SWITCH AC POWER - ON.
- (9) Set DIGITAL BEARING ROTATION METHOD switch in PATTERN SLEW position [See Optional Method for STROBE SLEW Step (24)].
- (10) Push STOP and RESET switches in that order (Stop and Reset lamps are ON - see note).
- (11) Set in beam size by pushing one of BEAMFORMER buttons. [Use (fifteen) when in doubt].
- (12) Push START switch (start lamp only is on).
- (13) Commutator running indicator flashes at a 10-cycle/sec rate.
- (14) Tune R390/URR to desired frequency.
- (15) Advance RF GAIN control until pattern is displayed on CRT.
- (16) Bearing Readout - Option 1

If mechanical CRT alidade is used go to Step (21).

(17) Bearing Readout - Option 2

If digital bearing readout is used, depress either CW or CCW SLEW DIRECTION switch and hold until CRT pattern rotates to a vertical position with positive deflection upward from the center.

- (18) Center the pattern over the 0° marker on the CRT. Rotation speed is controlled by SLEW RATE knob just above the SLEW DIRECTION controls. Maximum speed is full clockwise.
- (19) Read azimuthal angle in degrees (to 0.1 resolution) from the DIGITAL BEARING READOUT. If continued DF mode operation is desired, return to Steps (14), (15), (18) and (19) (mechanical alidade will no longer give correct bearing). To change array size, return to Step (10).
- (20) To switch to INTERCEPT MODE, Steps (18) through (20) must be followed. Depress STOP switch. BEAM boresight will stop at the bearing indicated or the digital readout. Go to Step (23).
- (21) If mechanical alidade is used, position the Mechanical cursor over the CRT pattern so that one of the engraved lines bisects the pattern.
- (22) Read azimuthal bearing from alidade on the CRT periphery. Continue at Step (14).
- (23) To return to DF mode, depress RESET switch, go to Step (11) and repeat Steps (11) through (21). Exit to correct intercept direction is not possible if Steps (21) and (22) are used.

(24) Bearing Readout - Option 3

An optional method of digital bearing readout is provided by permitting the electronic strobe to be superimposed over the CRT pattern without pattern rotation. To rotate strobe set DIGITAL BEARING ROTATION METHOD, switch in STROBE SLEW position and repeat Steps (10) through (15).

- (a) A line is first coincident with the 0° marker on the CRT. Depress the SLEW DIRECTION controls until the intensified line (STROBE) is superimposed over the pattern.

- (b) Bisect the pattern with STROBE.
- (c) Go to Steps (19), (20), (23) and (24).

NOTE: The STOP-RESET-START switches are connected in a latch-up arrangement; therefore, if a button is depressed out of the above sequence, the commutator will not run. For example, the most common cause is to push the RESET before STOP - which will erase the count from the ring counter (COMMUTATOR RUN flashing lamp is out), but the START LAMP remains ON. The STOP button will not function. To correct, depress all buttons in the correct sequence ending on STOP. Return to Step (9).

WORK SHEETS

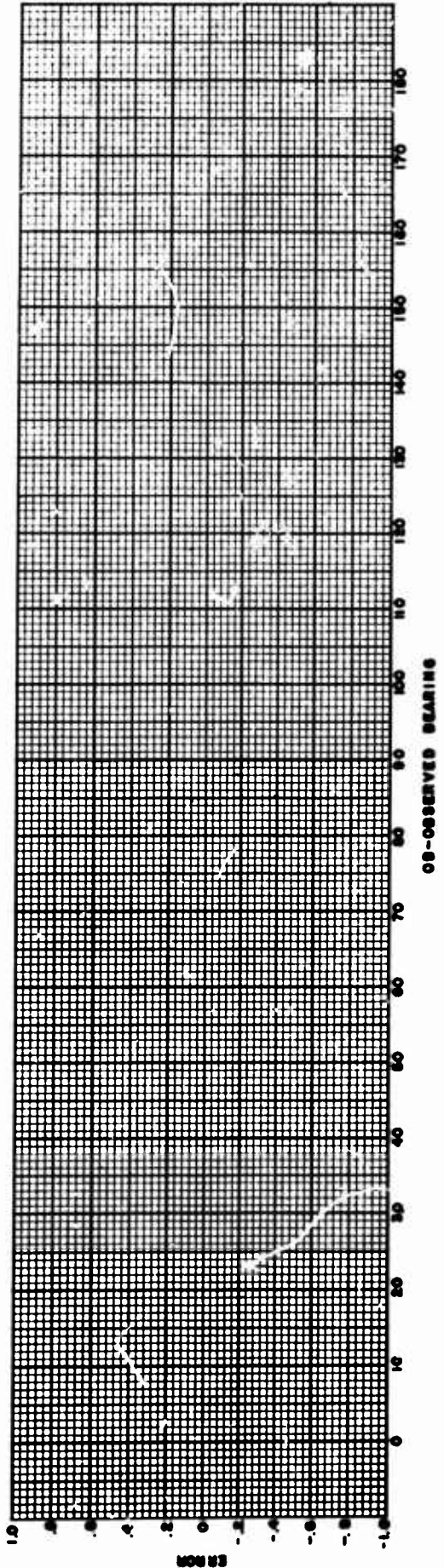

PLOT:
 ERROR - ANTENNA POSITION - OS
 READ:
 T.S. - OS - ERCT

DATE _____
 BY _____

BEVERAGE SYSTEM CALIBRATION

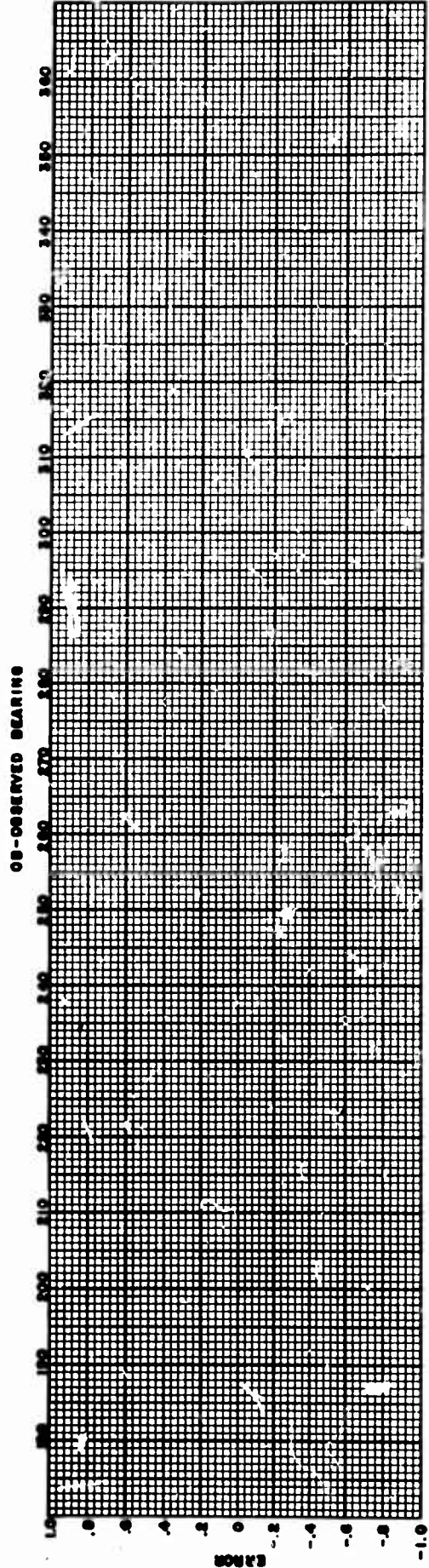

BEVERAGE SYSTEM WORK SHEET

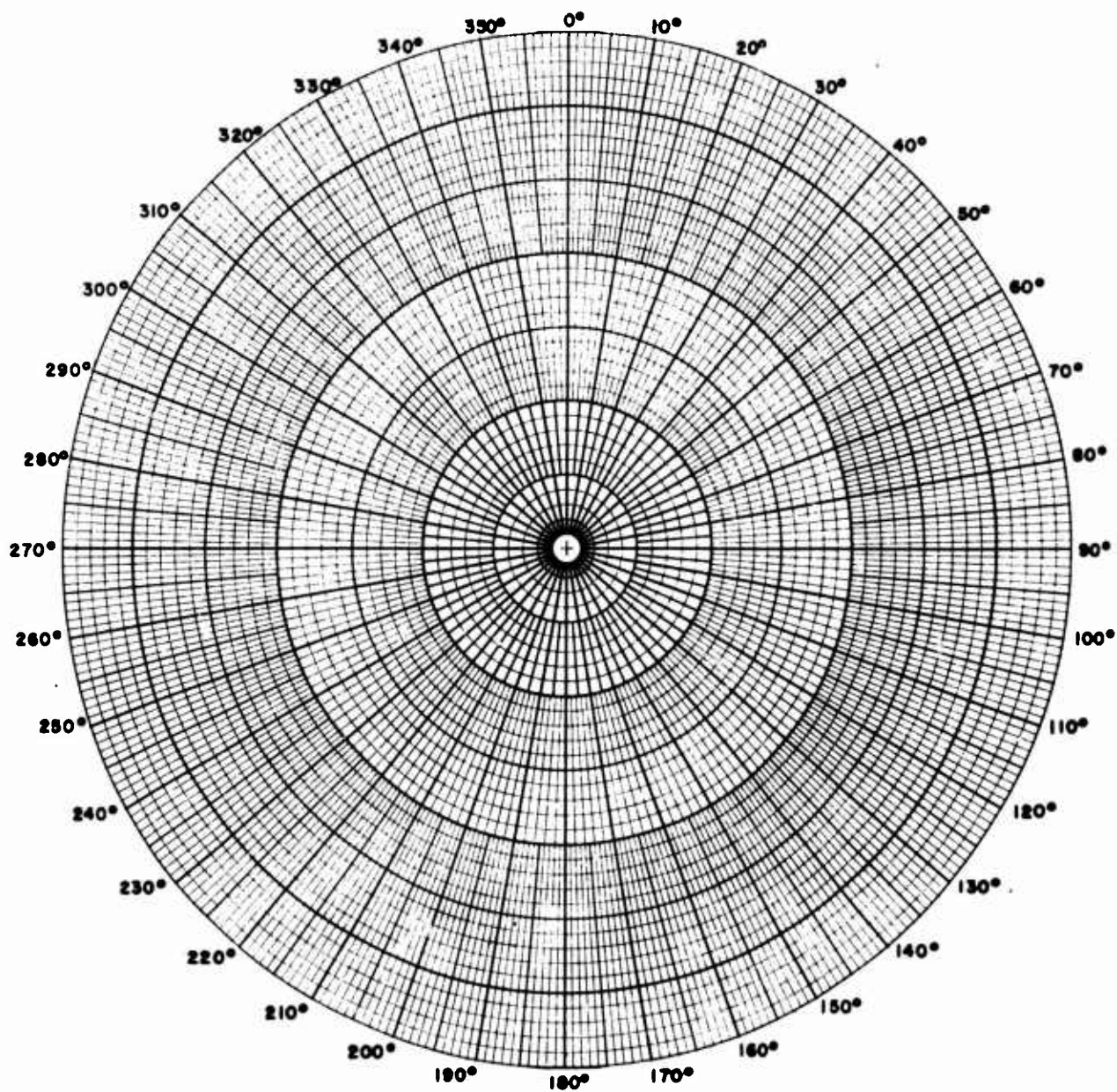

BEVERAGE SYSTEM PLANNING

Date _____ By _____ Scale _____

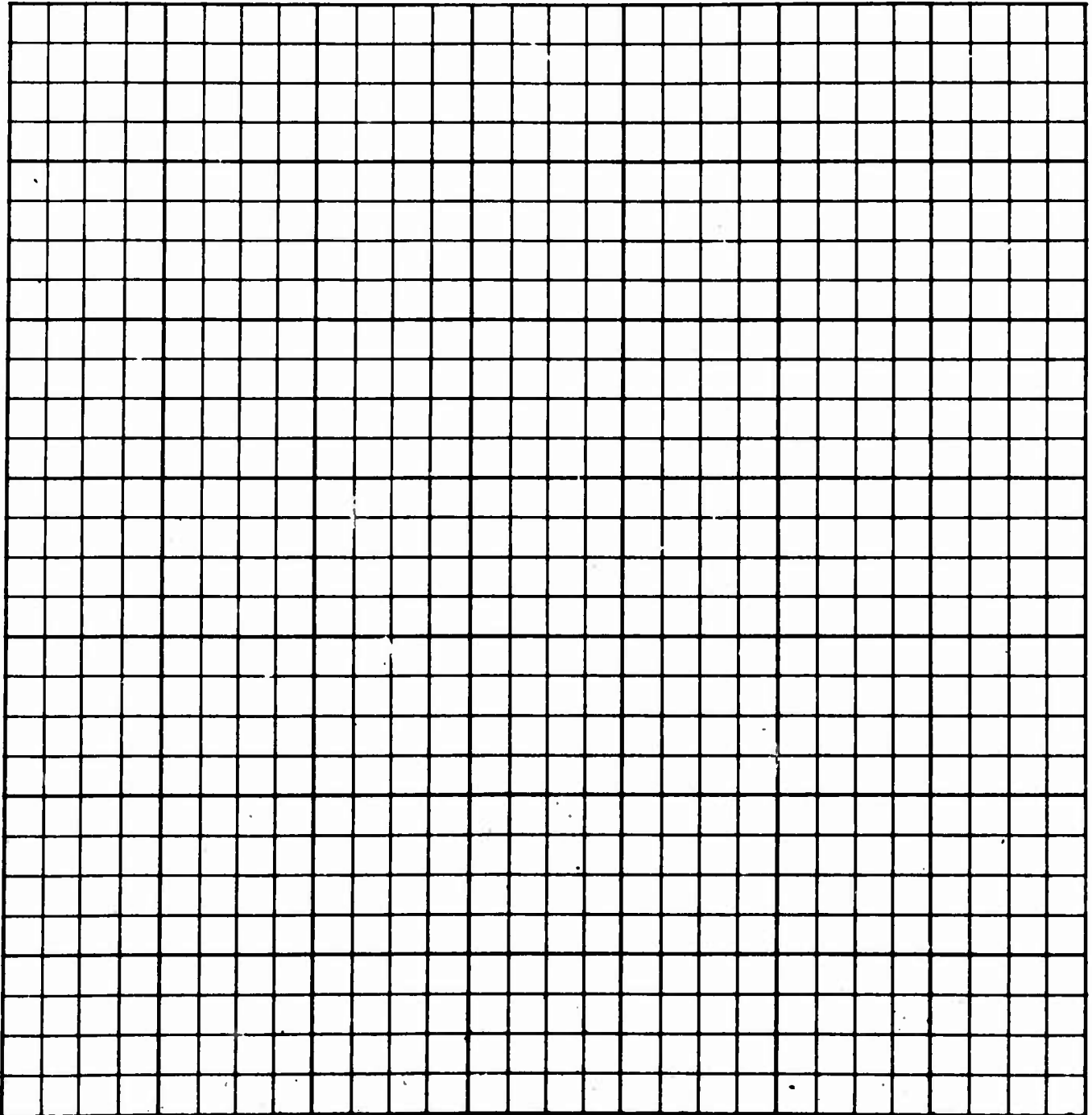

APPENDIX II

ABSTRACTS OF REPORTS CONCERNING BEVERAGE ANTENNA
RESEARCH AT SOUTHWEST RESEARCH INSTITUTE

CONTRACT NOBSR-85364

SwRI Project 06-1081

Interim Report No. 1, 15 May 1961, D. N. Travers

This initial report briefly summarizes in chronological sequence the important prior technical events which led to this project. Important literature pertinent to the Beverage antenna or the wave tilt phenomena i.. the high frequency range is referenced.

Site survey and construction work on the large sector Beverage array (as proposed in Southwest Research Institute's proposal 6-1442 of 7 November 1960) has been initiated. This array will be constructed in two stages; the initial stage being a 90-degree sector using 300-meter long antennas separated 2 degrees in azimuth and radiating outward from an inner circle radius of 100 meters. The antenna will be directed toward the northeast quadrant. At a later date, it is planned to extend the antennas to a length of 400 meters.

A second Beverage array covering a full 360 degrees of azimuth is also under construction. It will utilize 36 antennas, 120 meters long, spaced 10 degrees apart, and radiating outward from an inner circle radius of 80 feet. It is intended that the smaller array will be used for specific tests with a phase and gain matched twin channel receiver so as to make possible experiments which will lead to a continuous resolution method.

It is expected that the first pattern measurements with a field strength meter will be conducted before 1 June 1961 using antennas in the 360-degree array.

Interim Report No. 2, 15 June 1961, D. N. Travers

This report describes survey and installation work on two Beverage arrays which were briefly mentioned in the first interim report. The report also includes some preliminary results of data accumulated on the 360-degree Beverage array with respect to antenna impedance, velocity ratio, and patterns for vertical polarization. No bearing accuracy data are available as yet.

Site survey and construction work on the 360-degree Beverage array have been completed. This array has been placed in operation with a simple temporary commutating switch and a DAQ receiver and indicator. In addition, measurements of various parameters have been made on a selected antenna of this array. Patterns for difference connections of two Beverage antennas have been measured.

Construction of the large sector Beverage array is now under way and is approximately 30 percent complete. It is expected that this array will be placed in operation around the first of August.

Design work on a suitable commutator for both arrays has been conducted on two types of circuits. An inductive commutator consisting of ferrite toroidal core stators is in the initial stages of investigation. A second commutator using diode switches activated by a transistorized ring counter is also under construction. Completion of these commutators is expected by November 1961. In the meantime, simplified nonoptimum low-cost commercial switches are being used as test commutators.

Preparations are complete for initial tests of three Beverage antennas with a phase and gain matched twin channel receiver. The current delivery schedule for this receiver indicates that these tests can be performed sometime after 1 September 1961.

Interim Report No. 3, 15 July 1961, R. E. Cooper and D. N. Travers

Installation of both Beverage arrays described in earlier reports is now complete. Installation of receiving equipment for tests of the 360-degree Beverage antenna is complete. Installation of receiving equipment at the 72-degree sector array is approximately 50 percent complete.

Preparations for pattern and impedance measurements on the sector array are under way, and it is expected that initial data will be completed by 15 August. Measurements will be performed on azimuth patterns and bearing accuracy during August and September.

Design work on a suitable commutator for both arrays has continued using both inductive and diode switching circuits. Initial test results have been obtained on the inductive commutator. Construction of the diode switching system has progressed to the completion of a 36-section ring counter. Some additional initial testing has been performed on low-cost nonoptimum commercial switches.

A literature survey on the wave tilt phenomena has progressed to the selection of published equations which can be used to calculate three-dimensional patterns for the Beverage antenna which take into account surface waves and the electrical constants of the earth. From these analyses, it is believed that some qualitative estimate of the effect of downcoming angles on the Beverage antenna can be obtained. It is also apparent that the same analyses can yield procedures for calculating the effective height of the Beverage antenna.

Interim Report No. 4, 4 November 1961, R. E. Cooper and D. N. Travers

A skywave bearing test of the 360-degree Beverage array has been completed. Standard deviations between 3.5 and 4.3 degrees were obtained on identified signals between 5 and 25 megacycles for a sample of several hundred bearings. These results were obtained under a number of unfavorable equipment conditions including a very slow scan rate and wide spacing between antennas. In the future, it is believed that the standard deviation can be made to approach 2 degrees.

Equations for calculation of three-dimensional patterns for the Beverage antenna have been derived. Calculations of two elevation patterns were made.

The 72-degree sector array with 2-degree spacing has been completed including preliminary checks. Measured pattern data obtained agree with theoretical calculations for ground wave propagation.

Antenna parameters (transmission line constants and effective height) have been determined on single antennas in each array over the frequency range of 5 to 25 megacycles.

Work on the inductive commutator has been postponed in favor of a semiconductor diode switch. Development of this diode commutator is about 60 percent complete.

A comprehensive technical report which presents in detail all accomplishments of this program to date is now about 50 percent complete.

Interim Report No. 5, 7 February 1962, D. N. Travers and R. E. Cooper

Investigation of the Beverage antenna as the basis of a wide aperture high frequency direction finder has been under way for the past year. Analytical findings and test results are presented for two working circular arrays differing in size.

The first part of the current study has considered characteristics and design parameters of the single Beverage antenna. The antenna has many useful properties for HF DF including aperiodic impedance, highly directive azimuth patterns, wide aperture type response and very low installation cost and maintenance. Bandwidths greater than 30 to 1 are feasible. Effective heights of 10 to 1/2 meter are obtained between 3 and 30 megacycles with 300-meter long antennas. Elevation patterns have been investigated briefly.

The second part of the study considered circular arrays and methods of commutation. The circular array may be commutated in several ways, three of the most important being (1) sequential switching, (2) simplified Wullenweber type goniometer scanning, and (3) "sum and difference" scanning with a twin channel receiver. The first method offers low cost and good accuracy, the second better utilization of the aperture with averaging over a large area and a narrower beam. The third method offers very high resolution in a narrow azimuth sector.

Using the first method of simple sequential switching, a 360-degree array 900 feet in diameter (120-meter antennas) when tested as an operating direction finder on skywave transmissions in the range of 1.5 to 30.0 megacycles showed standard deviations in the range of 3.5 to 4.0 degrees. The larger array (300-meter antennas) using antennas 3 to 30 wavelengths long in a 72-degree sector when subjected to testing on similar signals showed standard deviations in the range of 0.96 to 1.04 degrees. These results indicate low horizontal polarization error.

Sum and difference type scanning was investigated with about 0.05-degree azimuth resolution obtained. Greater resolution may be obtained with improved indicating equipment and a true twin channel receiver. No experimentation with Wullenweber scanning has as yet been performed.

It is concluded that the Beverage antenna is suitable for wide aperture high frequency direction finding with accuracy comparable to other types of wide aperture systems and at lower cost than any other known type. For future consideration, the antenna has the added advantage of being readily adaptable to hardened sites, since no vertical elements are necessary.

Interim Report No. 6, 9 May 1962, R. E. Cooper and D. N. Travers

Initial phases (ordering of materials, site survey, etc.) of construction of a minimum land area 360-degree array of Beverage antennas, 300 meters long, 2 degrees apart in azimuth, have been started.

A time based linear display, using a solid state diode commutator has been tested. Under development is a simple method of using this commutator with a polar display on the DAQ indicator. A more extensive development leading to a larger, more accurate, and permanent polar display has been started.

Initial investigation of high angle of elevation signals has been started using a mobile transmitter. This transmitter has been sent out to distances of 150 miles. Results are not yet complete.

Work on extension of the theory of the Beverage antenna has been continued at a limited rate.

Interim Report No. 7, 27 July 1962, R. E. Cooper, P. E. Martin, and D. N. Travers

Classified Abstract.

Interim Report No. 8, 26 October 1962, R. E. Cooper, P. E. Martin, W. M. Sherrill, and D. N. Travers

Construction of minimum land area circular array of 300-meter long antennas is now complete. Extensive electrical measurements are currently being made on this array.

Construction of the 180-section diode switch commutator display system is under way. Construction should be essentially complete by early December.

A computer program has been written which considers signal elevation angles and can calculate resulting patterns for combinations of up to six antennas in phase and amplitude matched configurations. Results will be presented in a future report.

The original 360-degree array of 120-meter long antennas has been converted from 36 antennas spaced 10 degrees apart in azimuth, to an array of 180 antennas spaced 2 degrees apart. Construction is now complete except for lead-in cables and matching transformers which are currently being installed.

Final Development Report, 14 June 1963, P. E. Martin, W. M. Sherrill, and D. N. Travers

The work that has been accomplished during the ninth and last interim of contract NObsr-85364 has, of course, been extensions of some of the work already discussed in the previous eight interim reports, but the major efforts were directed toward these new tasks above. Consequently,

the research tasks performed over the life of the contract will be summarized as briefly as the details will allow, but emphasis will be on the results of work not heretofore reported. For those interested in a complete detailed discussion of all phases of the research program, reference should be made to interim reports five, six and seven. The preliminary work completed during the first nine months of the program is covered in detail in the fifth interim report dated 7 February 1962. During the nine-month period, two arrays of Beverage antennas were constructed. One array covered 360 degrees of azimuth with 36 antennas, each 112 meters long and uniformly spaced 10 degrees apart. The second array covered 72 degrees of azimuth with 42 antennas, each 300 meters long and uniformly spaced 2 degrees apart. Tests to determine the accuracy of the indicated bearing were conducted on each array utilizing mechanical commutator switches synchronized to the display drive of a modified DAQ D/F system. The computed standard deviations for both arrays (3 to 4 degrees for the 112-meter array; 1 degree for the sector array) were sufficiently good to show the feasibility of the use of the Beverage antenna in high frequency direction finding. At the conclusion of these tests, the 300-meter sector array was dismantled to permit construction of a full circular array of antennas. (a-1, b-3, c-1, d-1, e-1000, f-Progress report)

CONTRACT NOBSR-89345
SwRI Project 16-1360

Interim Report No. 1, 23 September 1963, P. E. Martin and D. N. Travers

Modification of the AN/FRD-10 Channel Watcher as a D/F receiver and indicator for use with a Beverage array and a 180-input diode commutator is now 100 percent complete. Plans were initiated in July to make bearing studies on the 112-meter Beverage array (112-meter long antennas spaced 2 degrees); however, a requirement to use the commutating system for specialized tests outside the United States necessitated postponement of these data. Bearing studies will be resumed as soon as the equipment is returned to Southwest Research Institute.

Analysis of results obtained on the crossed-over array indicate that experimental investigation of a crossover design may be conveniently carried out at the 112-meter site which now consists of noncrossed-over antennas. This investigation will be concerned with methods of isolation for frequencies above 10 megacycles in the crossover region.

Equations have been derived and programmed for the Institute's digital computer to calculate both azimuth and elevation patterns for various circular sector arrays of Beverage antennas. This program is ready for use, and patterns will be completed during the coming interim period.

Interim Report No. 2, 23 December 1963, D. N. Travers and P. E. Martin

The AN/FRD-10 channel watcher and the 180-input diode commutator have been returned to Southwest Research Institute. Extensive repair and troubleshooting were required to return the system to reliable operating condition.

A bearing accuracy test on the 112-meter circular array of Beverage antennas with 2-degree element spacing has been initiated. About 300 of a proposed 1000 useful bearings have been obtained to date. A standard deviation significantly less than that reported in 1961 for the same site with 10-degree element spacing is already apparent.

The theoretical study of the Beverage antenna(s) supported in part by an experimental program is continuing. A comprehensive pattern study for various electrical and mechanical parameters has shown that simple summation of signals from adjacent antennas will cause a significant reduction in the beamwidth and the polarization error while providing an increase in the system sensitivity.

Measurements of the wave tilt angle for ground wave propagation have been completed. In general, the results support the choice of constants used in the theoretical study.

Interim Report No. 3A, 23 March 1964, D. N. Travers, P. E. Martin and W. M. Sherrill

Classified Abstract.

Interim Report No. 3B, 23 March 1964, D. N. Travers, et al.

A detailed analysis is presented for a circular array of Beverage antennas over a conducting earth. Equations are derived for azimuth and elevation patterns for any number of similar antennas in the array taken any number at a time, spaced in any manner, and summed in any arbitrary manner with or without phasing. Of particular interest for HF direction finding applications are sector arrays of 10 to 20 antennas located 2 degrees apart and operated between 1 and 40 megacycles. Simple summing (nonphased) of typical sector arrays produces patterns which have greatly reduced beamwidth compared to single element patterns. At 10 megacycles, a 25-meter long single element, 1 meter high, has a 3-dB beamwidth of about 78 degrees, while a circular sector array of 21 similar elements 2 degrees apart has a beamwidth of about 18 degrees without phasing. Elevation patterns for short element, large sector arrays show similarly narrow azimuth patterns up to elevation angles of 70 degrees at 10 megacycles for an array diameter of less than 900 feet.

The analysis provides both ground wave and sky wave patterns. For sky wave patterns, the polarization of the incident field may be linear or elliptical (any condition between vertical and horizontal polarization). Calculations show the sector arrays considered so far to have low polarization error. Polarization error is further reduced as beamwidth is reduced.

The analysis also provides antenna impedance, antenna line constants, effective height, wave tilt angle and various other parameters. Calculated performance shows the antennas to have impedances and patterns normally associated with frequency independent antennas. The results show that D/F performance over a 100 to 1 frequency range extending as low as 1.5 megacycles should be obtained in a single array including good azimuth patterns at high elevation angles. Furthermore, the simplicity of the antenna element design permits what is probably the lowest cost wide aperture direction finder antenna array yet designed for the MF, HF, and VHF frequency ranges.

Calculated (and also as reported in Part II, measured) effective heights indicate that the summed sector arrays provide an adequate sensitivity with resulting effective heights ranging from a few meters to the vicinity of 100 meters. Bearing sensitivity is probably as good as present day instrumentation can utilize either in a scanning or fixed beam mode.

It is also apparent from the analysis that the performance of the antenna array is not highly dependent on a specific earth conductivity as in the case of some D/F antennas. Reception is improved by an increased wave tilt angle usually associated with poorly conducting earth. Thus, the system is probably more adaptable to varying site terrain than is the usual D/F system.

This is Part IV of a four-part report and is concerned primarily with theory. Part II is concerned with system design and performance for long range HF D/F, while Part III is a detailed report on measured accuracy of a 900-foot diameter array of 180 antennas. Part I was submitted in 1962. All theoretical background material necessary to the analysis has been reproduced in the Appendix.

Interim Report No. 4, 1 August 1964, D. N. Travers, et al.

Extensive operational tests and measurements have been performed on a circular array of Beverage antennas with the solid state commutator. Both the antenna array and the commutator have been considerably expanded since 1962. The Beverage antenna array was expanded from 36 to 180 elements, 112 meters long, spaced 2 degrees in azimuth. A new commutator was designed to allow sequential commutation of 180 inputs taken any number at a time.

Several experimental antenna pattern studies have been made using the AN/FRD-10(X-2) Channel Watcher D/F set and the commutator. Many experimental patterns and related tests have been completed and compared to theoretically predicted results. Consistent agreement indicates that the mathematical model of the Beverage antenna (developed and discussed in Part IV, this report, March 1964) can be accepted with confidence for both azimuth and elevation patterns.

The effects of horizontal polarization upon the apparent azimuthal angle of arrival of a signal have been investigated in some detail. The calculated results, for steady state conditions, indicated that errors of several degrees could occur, but it has been found in practice that polarization effects are of a transitory nature and can be easily recognized.

Additional theoretical studies have been made to investigate optimum arraying techniques (including external phasing) for circular arrays of Beverage antennas having a large inner radius compared to the element length. The results of these studies and the results of the investigation of crossed element minimum land area arrays have suggested that the feasibility of sampling an array around its outer periphery be investigated. Such a study will require some changes in the computer program in order to obtain proper integration and summation.

Interim Report No. 5, 30 October 1964, P. E. Martin and D. N. Travers

The fifth interim period of Contract NObsr-89345 has been devoted to modification of the Beverage antenna array by shortening the 180 elements to a length of 27 meters, modification of the mathematical model of the Beverage system to include sampling of the elements at the outer terminals and design and construction of a new solid state RF commutator with 360 inputs.

The program for the year, June 1964 through May 1965, includes: (1) specification and construction of an improved shorter antenna length between 25 and 60 meters for the frequency range of 2 to 30 megacycles/second which will allow the largest phase center circle to be maintained within the present 900-foot diameter site, (2) the construction and modification of the revised commutator with 360 inputs, (3) bearing accuracy and array pattern measurements of the newly constructed array and (4) continuation of the theoretical studies emphasizing sampling of the antenna terminals at the periphery of the array and the use of external phasing.

Interim Report No. 6, 31 December 1964, P. E. Martin and D. N. Travers

The major effort during the past quarter has been devoted to the construction of the 360-input solid state commutator. The first of twelve identical 30-input modules is nearly complete with the remaining eleven expected to be completed during the next quarter.

Power dividers, high pass filters and phase matched lead-in cables have been installed at the antenna site. Testing of the circular array of 27-meter long elements spaced every 2 degrees in azimuth will begin shortly.

Array patterns calculated from the modified computer program (modified to allow array calculations for feed points at the periphery of the array) have been plotted and show very little change from patterns calculated, using the same number and spacing of elements, for feed points located at the inner array radius.

Interim Report No. 7, 15 April 1965, P. E. Martin, et al.

The construction of the 360-input solid state commutator has continued to require the major portion of the effort during the past quarter. Six modules of 30 inputs each and a master control unit have been completed, tested and are now operational at the Beverage array site. A pattern study now under way, using two 180-input RF commutators connected in parallel to the inner feed points of the array of 27-meter long elements has been primarily devoted to experimenting with the outputs of the two commutators differentially connected. By such technique, a null is formed in the azimuthal direction of arrival of signal. The results obtained by the difference connection and inverted null display are very encouraging, and it appears that a significant improvement in array performance can be obtained on skywave signals.

Interim Report No. 8, 20 July 1965, P. E. Martin and D. N. Travers

Construction of the digital commutator to provide capability of sampling 360-antenna inputs has been completed including in-line high pass filters for each antenna circuit.

A bearing accuracy test on the Beverage antenna array has been initiated. However, sufficient data have not been obtained at this time to enable a useful analysis to be performed.

Interim Report No. 9, 31 January 1966, P. E. Martin and R. Lorenz

This is the first interim report under Contract NObsr-89345 following joint funding by the U.S. Navy and Army. Prior work under subject contract was funded solely by the U.S. Navy, while research for the U.S. Army was performed under Contract DA-36-039-AMC-02346(E).

Efforts during the reporting period have been directed toward the construction of concentric circular arrays of Beverage antennas, single element sensitivity measurements, and commutator improvement and adjustment. In order to facilitate the research during the contract period, all Beverage array activity has been transferred to a single site. Both experimental circular arrays will have 75-meter elements spaced every 2-degrees azimuth; an interior array (array A-I) has an inner feed point radius of 46 meters, while the outer array (array A-II) has an inner feed point radius of 131 meters.

Signal-plus-noise-to-noise ratio (sensitivity) measurements have been completed as a function of frequency for single Beverage elements 27, 50, and 75 meters long located 1.0, 0.5, 0.1, and 0.0 above the ground. When the

data were compared to similar sensitivity measurements obtained from a 29-foot vertical monopole, the Beverage elements having lengths of 50 and 75 meters showed significant improvements over the monopole at nearly all frequencies. The most favorable height of a Beverage element appears to be 0.1 meter above the ground.

Interim Report No. 10, 30 April 1966, P. E. Martin and R. Lorenz

Construction of concentric Beverage antenna arrays each having 75-meter elements, 1 meter above the ground, is complete except for installation of a third set of feet cables. Check and testing have been completed on the arrays and the instrumentation. Performance data for array gain and array sensitivity have also been completed for the 1-meter element height. The improvement in sensitivity as a function of consecutive elements used in the active portion of the array is extremely good and easily overcomes the sensitivity degradation due to the commutation system. In addition, over 20-dB gain in signal is attained by the direct summation (without phasing) via the commutator of antenna input voltages and agrees very well with representative theoretical values.

An AN/TRD-15 Doppler Direction Finder system has been received as GFE from the U.S. Army and installed at the field site near the Beverage array. Testing is in progress. A program to obtain comparative performance data for both the Beverage and the Doppler systems is planned.

Interim Report No. 11, 1 August 1966, P. E. Martin

The major effort during the past quarter has been devoted to the accumulation of bearing accuracy data on the Beverage arrays and the AN/TRD-15 Doppler array. Approximately 3,000 bearings, many simultaneous intercepts on both Beverage and Doppler, have been obtained.

The large Beverage array A-II has been lowered from the original 1-meter height above ground to a nominal 4-inch height. Initial measurements indicate an improvement in performance below 5 MHz.

Work has also begun on the transportable Beverage array and support equipment that is to be delivered at the close of the contract period.

Interim Report No. 12, 1 November 1966, P. E. Martin

The evaluation of performance of the two concentric Beverage arrays is continuing. Over 13,000 bearings have been accumulated on the Beverage

DF systems and an AN/TRD-15 Doppler system. Statistical analysis of the data for bearing accuracy as a function of array, frequency, distance, etc., is under way.

The preparation of a transportable Beverage array, instrumentation, and instruction book is continuing. A rapid erection technique for the antennas and feed cables has been developed and tested.

Interim Report No. 13, 1 February 1967, P. E. Martin and C. Dodge

The preparation of the transportable Beverage antenna array and instrumentation is complete and ready for delivery. An instruction book for the installation, operation and maintenance of the transportable system is being prepared.

The evaluation of performance data for the Beverage antenna arrays and the AN/TRD-15 Doppler system is continuing. Additional bearing accuracy data will be obtained for the inner Beverage array A-I which has been lowered from a 1-meter height above ground to approximately 0.25 meter.

Interim Report No. 14, 1 May 1967, P. E. Martin

The transportable Beverage antenna array, excluding instrumentation, has been delivered to the U.S. Army at Fort Monmouth. An instruction book for the installation, operation and maintenance of the transportable system will be published shortly.

Additional bearing accuracy data have been obtained for the inner Beverage Array A-I at the new height above ground of 0.25 meter. Simultaneous intercepts with the above data were obtained on the AN/TRD-15 Doppler.

CONTRACT DA-36-039-AMC-02346(E)

SwRI Project 06-1386

Interim Report No. 1, 30 September 1963, P. E. Martin, D. N. Travers and M. P. Castles

The primary efforts during the first quarter of the contract have been devoted to the acquisition of experimental data for single wire Beverage antennas of dimensions consistent with contract objectives. Treatment of the single Beverage antenna as a transmission line has made it possible to obtain data for the calculation of line constants for antenna heights of 1 and 2 meters. Effective height measurements have also been initiated, with experimental data obtained for antenna lengths of 300 and 412 meters, and heights of 1, 2 and 3 meters. A theoretical effective height study has considered antenna lengths of 112, 187, 300 and 412 meters and heights of 0.7, 1, 2, 4 and 7 meters. Agreement is satisfactory, and it is believed the theoretical calculations may be used with confidence.

A theoretical pattern study for both azimuth and elevation planes for 300-meter antennas is under way. The D/F site for a circular 300-meter array has been cleared, and antenna locations have been surveyed.

An investigation of RF gates for a D/F commutator is being conducted to seek a device with an output relatively free of control signal transients. Three solid state circuits are being experimentally tested.

Interim Report No. 2, 31 December 1963, P. E. Martin, D. N. Travers, M. P. Castles and R. Lorenz

Initial results of theoretical pattern studies are presented which show trends leading to optimum designs for the special requirements of the U.S. Army. Sufficient evidence has been obtained to suggest that extensive investigation of circular arrays of Beverage antennas with larger inner radii be conducted for the 2 to 10 megacycles/second range in the hope of obtaining much better evaluation patterns than have been thought possible to date.

Additional results of the impedance measurements including mutual coupling are presented. Some data obtained are withheld until the effects of a nonoptimum measuring technique can be evaluated by additional measurements.

A push-pull amplifier circuit has been designed and evaluated for use as the RF switch in a solid state commutator. Design of the commutator logic

circuits is essentially complete and construction is expected to begin in the near future. Performance of this switch element circuit is significantly better than any previous commutator switches developed at this laboratory.

An examination of the DFG-2 deflection circuits has indicated that a modification will be required to properly display the nonsymmetrical patterns obtained from a circular array of Beverage antennas. Even with this modification, however, recent results for the Navy Department research work on a smaller array indicate that the accuracy of the system will be limited by the DFG-2 instrumentation.

Interim Report No. 3, 31 March 1964, P. E. Martin, D. N. Travers, M. P. Castles and R. Lorenz

Theoretical pattern studies have been continued to investigate Beverage antenna performance as a function of angle of elevation, frequency, array radii and ground constants. A recent comparison of theoretical and experimental patterns has shown that the mathematical model of the Beverage antenna may be accepted with confidence.

Other studies show: (1) that no significant reduction in pattern bandwidths by linear summation of antenna inputs is predicted when the radius of the points of summation is small compared to a wavelength and (2) the effect of poor ground conductivity indicates that reasonable performance of the frequency band of 2 to 32 megacycles/second will require that the element lengths be less than 50 meters.

The experimental program has included the continued measurement of input impedance, mutual impedance, effective height and the investigation of terrain effects at sites remote from San Antonio. Results of these tests show that (1) a reasonably flat input impedance can be obtained over the frequency range of 2 to 32 megacycles/second, (2) a good impedance transformation to a 75-ohm line can be obtained (less than a 1.15:1 mismatch at 75 ohms) for the same frequency range, (3) the effect of mutual impedance varies from 1,800 ohms when two elements are parallel and 1 meter apart to greater than 7,500 ohms when the spacing is 5 meters, and (4) little is to be gained in antenna sensitivity from element heights greater than 2 meters if the ground conductivity is high. An analysis of data obtained to investigate terrain effects cannot be made until measurement data are obtained from other sites.

The construction of the 300-meter circular array has been completed and testing has begun. A very limited pattern study has indicated that reasonable patterns can be obtained over the frequencies of 2 to 27 megacycles/second.

The construction of the 180-stage solid state commutator is proceeding on schedule. Interim testing of the ring counter and the RF amplifier-gates is under way. Results to date do not show any departure from the expected performance.

Final Progress Report, 30 September 1964, P. E. Martin, D. N. Travers, M. P. Castles and R. Lorenz

A 1-year program has been completed on the use of the Beverage antenna in direction finding and intercept systems for specialized U.S. Army requirements in the frequency range of 1.5 to 30 megacycles/second. Performance has been emphasized for sky wave signals, and particularly from transmitting sources 50 to 300 miles away. Antenna attenuation constant, velocity ratio, impedance and effective height have been experimentally measured and theoretically determined versus frequency, antenna height, length and the ground constants. Sufficiently good experimental and theoretical agreement has been obtained to permit acceptance of an existing theoretical model of the Beverage array which is well suited for further investigation of modes of operation not easily or cheaply investigated experimentally.

Experiments show an element height of 2 meters or lower is optimum for the 3 to 10 megacycles/second range. Still lower element heights (on the order of 0.5 meter) are probably optimum when the antenna is short. Tests with ground wave signals from a local target transmitter have indicated that an element should be at least one-half wavelength long to obtain unidirectional patterns but no longer than one wavelength to maintain signal sensitivity at high elevation angles.

A sequentially operated solid state 180-antenna input commutator has been designed, constructed and operated successfully. A new low level RF switch design has overcome disadvantages of a previously developed switch made for the U.S. Navy. Linear summation of antenna inputs can now be accomplished without insertion loss and with pedestalless, almost transient free, operation.

Theoretical calculations show that external phasing of individual elements will produce narrow azimuth plane radiation patterns relative to simple non-phased summing. Furthermore, it appears possible to approximate optimum phasing, by a simple scheme that could be accomplished with two solid state sequential commutators of the type now in use.

Two circular arrays, the first consisting of 300-meter long elements on a 25-meter feedpoint radius, and the second 27-meter long elements on a 109-meter feedpoint radius, each with elements spaced 2 degrees in azimuth,

have been tested. Statistical analysis has been completed on bearing data for the two arrays, for both short and long range signals. Tests on the short 27-meter long elements, with signals originating 50 to 100 miles from the D/F, show directional patterns on sky waves arriving at elevation angles between 65 and 80 degrees.

APPENDIX III

DIGITAL COMPUTER PROGRAM FOR CALCULATION OF GREAT
CIRCLE BEARING AND DISTANCE BETWEEN
TARGET AND DF SITE

See Reference 3, List of References

The equations for great circle bearing and distance have been programmed for digital computation as shown in the simplified block diagram.

For the great circle bearing of B with respect to A, the angle θ_A given by

$$\theta_A = \cot^{-1} \left[\frac{1}{2 \cos L_B} \cdot [X - Y] \right]$$

where

$$X = \sin (L_A + L_B) \cdot \tan (D/2)$$

$$Y = \frac{\sin (L_A - L_B)}{\tan (D/2)}$$

L_A = Latitude of A

L_B = Latitude of B

D = Difference in longitudes ($D < 180^\circ$)

Since $D < 180^\circ$, that is, θ_A is the short route bearing, then θ_A comes out either East or West of North. Since the angles $(L_A + L_B)$ and $(L_A - L_B)$ are less than 180° , the signs of X and Y are the signs of $\sin (L_A + L_B)$ and $\sin (L_A - L_B)$.

By allowing X and Y to be determined as above, the angle θ_A is obtained as a positive angle less than 90° which is measured E or W of North for $(X - Y)$ positive, and E or W of S for $(X - Y)$ negative. This convention determines the quadrant of the true bearing which is then expressed as an azimuth angle on the basis of 360° .

The great circle distance (d) in degrees is calculated by

$$\sin^2 \frac{d}{2} = M^2 + N^2$$

where

$$M = \frac{\cos}{\sin} (L_M) \sin(D/2)$$

$$N = \frac{\sin}{\cos} (L_N) \cos(D/2)$$

$$L_N = \left| \frac{L_A - L_B}{2} \right|$$

$$L_M = \left| \frac{L_A + L_B}{2} \right|$$

The upper alternative is chosen for $L_M + 45^\circ > L_N + D/2$, the lower for $L_M + 45^\circ < L_N + D/2$.

The following coordinate signs conventions are adopted:

N Latitude is a positive angle with respect to the Equator.

S Latitude is a negative angle with respect to the Equator.

E Longitude is a negative angle with respect to the prime meridian.

W Longitude is a positive angle with respect to the prime meridian.

The application of these conventions and the other Millington [3] conventions is seen from consideration of the program block diagram.

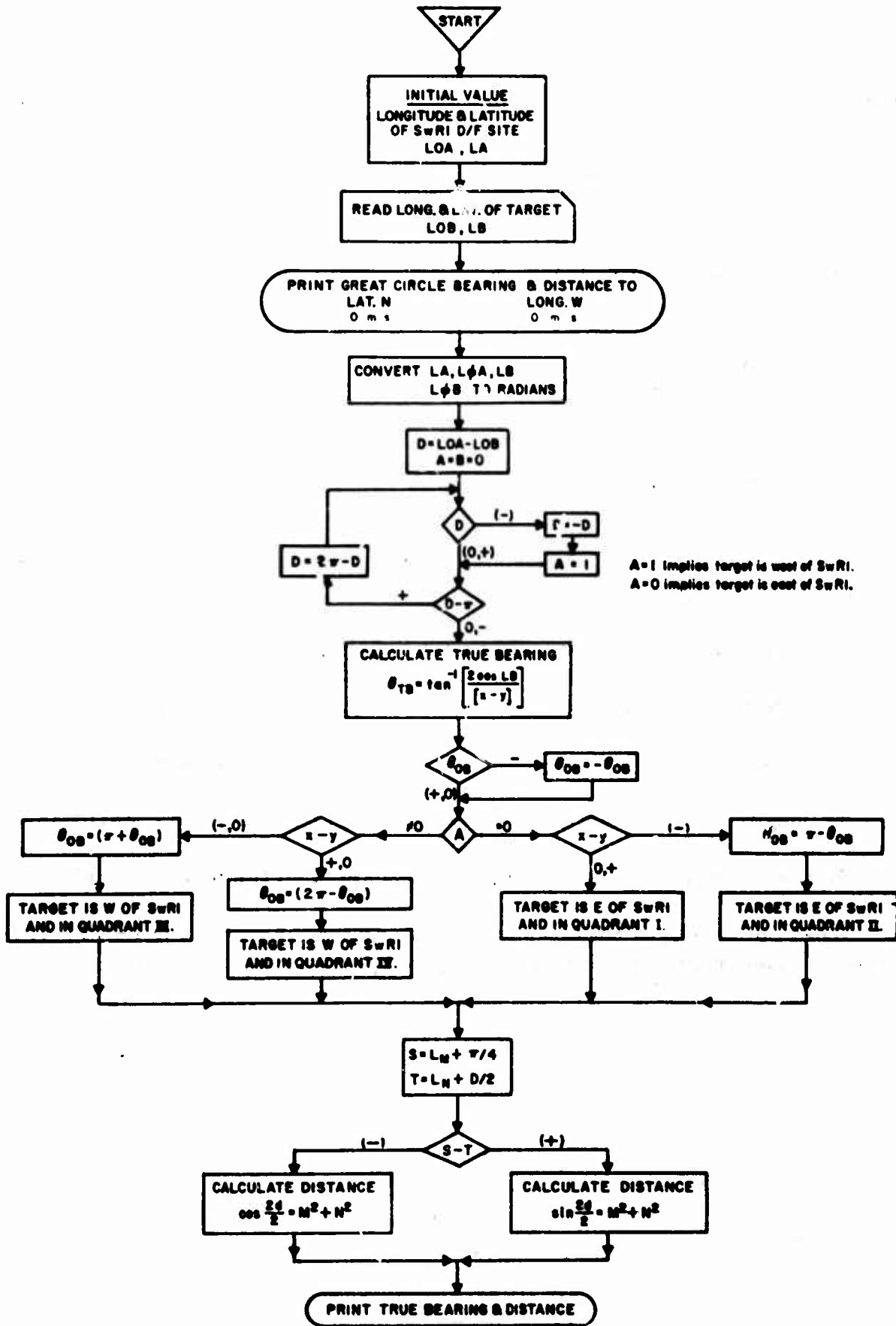

COMPUTER PROGRAM FOR TRUE BEARING CALCULATIONS

```

• GREAT CIRCLES PROGRAM
  DIMENSION K(16)
1  FORMAT (1H1,15X,53HGREAT CIRCLE BEARING AND DISTANCE FROM D/F SITE      2
  1 TO )                                                                           3
2  FORMAT (16A4)
3  FORMAT (6F10,3)                                                                 5
4  FORMAT (1H0,4X,12HTRUE BEARING)                                             6
5  FORMAT (19H DECIMAL DEGREES = ,F15.8,12H DEGREES = ,19,13H MIN
  1UTES = ,15,13H SECONDS = ,15)
6  FORMAT (1H0,40X,21HGREAT CIRCLE DISTANCE)                                  9
8  FORMAT(15H LATITUDE NORTH,25X,14HLONGITUDE WEST)
40 FORMAT (3F10,3,10X,3F10,3)
7  FORMAT(11H DEGREES = ,15,13H MINUTES = ,15,13H SECONDS = ,
  15/ 11H MILES = ,F15.8,17H KILOMETERS = ,F15.8,20H NAUTICAL      11
  2 MILES = ,F15.8//)
100 FORMAT (16A4,2X,16,1X,F7,1)
C  SWRI SITE IN SA 98 DEGREES 37 MINUTES 14 SECONDS WEST LONGITUDE      13
C 29 DEGREES 26 MINUTES 10 SECONDS NORTH LATITUDE
  CALL PAGE (-1)
  DEG=57,295779                                                                14
  RAD=0,0174533                                                                15
  PI=3,1415926536                                                             16
  READ 3, DLOA,ALOM,SLOA,DLA,ALM,SLA
  AL=DLA+ALM/60,0+SLA/3600,0                                                  21
  ALO=DLOA+ALOM/60,0+SLOA/3600,0                                             22
  SLO=180,0-ALO
  AL=AL*RAD                                                                    24
  ALO=ALO*RAD                                                                    25
  SLO=SLO*RAD                                                                    26
9  PRINT 1                                                                      27
41 CALL PAGE (12)
  READ 2, K                                                                      28
10 PRINT 2, K                                                                    30
  PRINT 8
  READ 3, BLOD,BLOM,BLOS,BLD,BLM,BLS
  PRINT 40, BLD,BLM,BLS,BLOD,BLOM,BLOS
  BL=BLD+BLM/60,0+BLS/3600,0                                                  32
  BLI=BLOD+BLOM/60,0+BLOS/3600,0                                             33
  BL=BL*RAD                                                                      34
  BLI=BLO*RAD                                                                    35
  I=6                                                                              36
  B=1,0
  C=1,0                                                                           38

```

IF (BLO) 11,11,13	39
11 IF (SLO+BLO) 12,12,13	40
12 I=1	41
13 D=ALO-BLO	42
14 IF (D) 15,16,16	43
15 D=-D	44
I=1	45
16 IF (D-PI) 18,18,17	46
17 D=2,0*PI-D	47
GO TO 14	48
18 TAN=SINF(D/2,0)/COSF(D/2,0)	49
XL=AL+BL	50
19 IF (ABSF(XL)-PI/2,0) 23,23,20	51
20 IF (XL) 21,22,22	52
21 R=-1,0	53
22 XL=PI-ABSF(XL)	54
GO TO 19	55
23 X=B*SINF(XL)*TAN	56
YL=AL-BL	57
24 IF (ABSF(YL)-PI/2,0) 26,26,25	58
25 YL=PI-ABSF(YL)	59
C=-1,0	
GO TO 24	61
26 Y=C*SINF(YL)/TAN	62
TB=ATANF(2,0*COSF(BL)/(X-Y))	63
IF (TB) 27,28,28	64
27 TB=-TB	65
28 IF (I) 32,29,32	66
29 IF (X-Y) 31,30,30	67
30 TB=TB*DEG	68
GO TO 35	69
31 TB=(PI-TB)*DEG	70
GO TO 35	71
32 IF (X-Y) 34,33,33	72
33 TB=(2,0*PI-TB)*DEG	73
GO TO 35	74
34 TB=(PI+TB)*DEG	75
35 HH=ABSF((AL+BL)/2,0)	76
MN=ABSF((AL-BL)/2,0)	77
S=HH*PI/4,0	78
T=MN*D/2,0	79
IF (S-T) 37,36,36	80
36 F=COSF(MH)*SINF(D/2,0)	81
G=SINF(MN)*COSF(D/2,0)	82
SI=F**2+G**2	83
DIS=2,0*ATANF(SQRTF(SI)/SQRTF(1,0-SI))*DEG	84
GO TO 38	85
37 F=SINF(MH)*COSF(D/2,0)	86
G=COSF(MN)*SINF(D/2,0)	87
CO=F**2+G**2	88
DIS=2,0*ATANF(SQRTF(1,0-CO)/SQRTF(CO))*DEG	89
38 PRINT 4	90
L=TB	91
FMI=(TB-L)*60,0	92
MIN=FMI	93
SEC=(FMI-MIN)*60,0	94
IS=SEC	95
PRINT 5, TB,L,MIN,IS	96
PRINT 6	97
ID=DIS	98
FMI=(DIS-ID)*60,0	99
MN=FMI	100

```

SC=(FMN-MN)*60.0
JS=SC
RK=DIS*111.1
SM=DIS*69.1
RN=DIS*60.0
PRINT 7, ID,MN,JS,SM,RK,RV
ISM=SM*0.5
PUNCH 100, K,ISM,TB
PUNCH 100, K,ISM,TB
GO TO 41
39 CONTINUE
END
SUBROUTINE PAGE (M)
M=NEGATIVE TO INITIALIZE, ZERO TO FORCE PAGE ,POSITIVE INTEGER
6 FORMAT(2H .)
7 FORMAT (5X, 5HPAGE ,I2/ 141///// )
IF(M)1,5,3
1 LC =0
N =1
RETURN
3 IF(LC*M-55)4,4,5
4 LC =LC*M
RETURN
5 K=55-LC
DO 23 I=1,K
PRINT 6
23 CONTINUE
PRINT 7,N
N=N+1
LC=0
GO TO 3
END

```

101
102
103
104
105

106
109

98.0 37.0 14.0 29.0 26.0 10.0

APPENDIX IV

BEARING ERROR STATISTICS PROGRAM
FOR DIGITAL COMPUTER

[Faint, mostly illegible text, likely a program listing or description]

A program for the CDC 3600 digital computer has been written to calculate the various statistical parameters used to describe the accuracy of the direction finder system.* The purpose of the program is to analyze observed bearing data by calculating the error for each observed bearing. This error is then sorted into an appropriate error range so that a histogram frequency distribution of number of errors versus error range is obtained.

The observed bearing may also be accompanied by a calibration factor which removes instrumental errors. Therefore, calculations of the error distribution including uncalibrated and calibrated observed data are available.

The program consists essentially of two calculations, the bearing error and the statistical parameters. The error (ϵ) for each bearing is calculated according to the formula

$$\epsilon = OB - TB \text{ (no calibration)}$$

$$\epsilon = OB - TB - CAL$$

where

OB = observed bearing

TB = true bearing

CAL = instrument calibration factor (not available for AN/TRD-4A system at this time)

The computer accumulates the number of bearings with errors falling within given error limits to establish the frequency of error distribution for some maximum or minimum limits (\pm a specified number of degrees) on either side of the true bearing. The desired sorting increment is also prescribed in the program input so that the error is assigned to an appropriate range within the distribution limits. If the error is greater than the distribution limits in absolute value, it is possible to disregard the information producing the error and to calculate the statistical parameters with wild bearings thrown out.

The statistical parameters calculated for the error distribution are (1) the sample size N, (2) the average error $\bar{\epsilon}$, given by

$$\bar{\epsilon} = \frac{\sum \epsilon}{N}$$

*A complete description of the statistical program is given in Reference 3 in the List of References.

(3) the sample variance

$$\sigma^2 = \frac{\sum \epsilon^2 - N\bar{\epsilon}^2}{N - 1}$$

(4) the standard deviation

$$\sigma = \sqrt{\sigma^2}$$

(5) the 95-percent confidence limits

$$1.96 \sigma$$

(6) the probable error

$$PE = 0.6745 \sigma$$

These parameters are tabulated in the program output followed by the frequency of error distribution at the increments specified within the Maximum-minimum limits. The first distribution is an unmodified distribution which includes all the data read from the input cards including those data which exceeded the distribution limits. The distribution print includes the error range (error increment), number of bearings obtained within that range, the percent of the total events for that range and the cumulative percentage.

A second distribution is the modified distribution which includes only that data falling between the error limits specified.

The output data from the computer are sufficient to statistically analyze the D/F system accuracy. Data describing the accuracies of the Beverage DF System and the AN/TRD-15 are included in Volume II to this report.

C	BEARING STATISTICS	1
C		2
	DIMENSION C(2000), CC(2000), D(1000), K(10)	3
1	FORMAT (1H1,24HBEARING ERROR STATISTICS,/))	4
2	FORMAT (1H0,35HFREQUENCY DISTRIBUTION ERROR LIMITS,/))	5
3	FORMAT (2I4)	6
4	FORMAT (3F7,3,2I2)	7
5	FORMAT (2(2X,F5,1),2X,I4,2X,F5.1,53X)	8
6	FORMAT (1H ,14HMAXIMUM ERROR=,F7,3,14HMINIMUM ERROR=,F7,3,10HBIN W 1DTH=,F7,3,/,/)	9
7	FORMAT (1H ,11HUNCALIBRATED DATA - SAMPLE SIZE MEAN ERROR VARIA 1NCE STANDARD DEVIATION PROBLEM ERROR 95 PFRCENT CONFIDENCE)	10
8	FORMAT (1H ,24X,15,5(X,E15,8))	11
9	FORMAT (1H ,109HCALIBRATED DATA - SAMPLE SIZE MEAN ERROR VARIANC 1F STANDARD DEVIATION PROBLEM ERROR 95 PERCENT CONFIDENCE)	12
10	FORMAT (1H ,22X,15,5(X,E15,8))	13
11	FORMAT (1H ,22HFREQUENCY DISTRIBUTION)	14
12	FORMAT (1H ,26HUNCALIBRATED,DATA CMINUS=,E16,8,6HNCMIN=,E16,8,6HC 1PLUS=,E16,8,7HNCPLUS=,E16,8)	15
13	FORMAT (1H ,24HCALIBRATED DATA CMINUS=,E16,8,6HNCMIN=,E16,8,6HCPL 1US=,E16,8,7HNCPLUS=,E16,8)	16
14	FORMAT (1H ,82HUNCALIBRATED DATA ERROR NUMBER EVENTS P 1ERCENT EVENTS TOTAL PERCENT)	17
15	FORMAT (1H ,33X,F7,3,7X,E16,8,4X,E16,8)	18
69	FORMAT(1H ,10X,F12,5)	19
16	FORMAT (1H ,80HCALIBRATED DATA ERROR NUMBER EVENTS PER 1CENT EVENTS TOTAL PERCENT)	20
17	FORMAT (1H ,31X,F7,3,7X,E16,8,4X,E16,8)	21
70	FORMAT(1H , 8X,F12,5)	22
18	FORMAT (1H0,17HCALL DISTRIBUTION,/))	23
19	FORMAT (1H ,28H CALL NUMBER OF EVENTS)	24
20	FORMAT (1H ,2X,15,12X,F7,1)	24A
21	FORMAT (1H ,23HTHE COMPLETE STATISTICS)	25
22	FORMAT (1H1,52HMODIFIED DISTRIBUTION WITH CMIN AND CPLUS ELIMINATE 1D)	26
63	FORMAT (I4)	27
68	FORMAT (10A8)	27A
71	FORMAT (1H0,10A8)	28
64	WRITE (61,1)	29
66	READ (60,3) LC,LD	30
67	READ (60,4) ERMAX,ERMIN,DEL,LCALO,MOD	31
	READ (60,68) K	32
	WRITE (61,71)K	32A
	WRITE (61,2)	32B
	WRITE (61,6) ERMAX,ERMIN,DEL	32C
	LM=(ERMAX-ERMIN)/DEL	36A
	CMNC=CMC=CPNC=CPC=EMNC=EPNC=EMC=EPC=MSQNC=PSQNC=MSOC=PSOC=SUMNC=0	33
	SUMC=SONC=SQC=R=0	35
	N=0	36
	DO 23 M=1,LC	37A
	C(M)=0	37B
	CC(M)=0	34
23	CONTINUE	37
	DO 24 LC=1,LD	38
	D(LC)=0	39
24	CONTINUE	40
25	READ (60,5) TB,09,NCALL,CALIB	41
	IF (TB=400) 26,38,38	42
26	D(NCALL)=D(NCALL)+1	43
	N=N+1	44
	NC=N	45
		46
		47
		48
		49
		51
		52
		53A

		538
		53
		54
		55
		56
		57
		58
		59
		60
27	C(1)=C(1)+1	61
	GO TO 32	62
28	CHNC=CMNC+1	63
	EHNC=EMNC+ERVC	64
	MSQNC=MSQNC+ERNCC**2	65
	GO TO 32	66
29	M=(ERNCC-ERMAX)/DEL	67
	M=M+LH	68
	IF (M-LH) 30,30,31	69
30	C(M)=C(M)+1	70
	GO TO 32	71
31	CPNC=CPNC+1	72
	EPNC=EPNC+ERVC	73
	PSQNC=PSQNC+ERNCC**2	74
32	IF (ERRC-YC) 34,33,35	75
33	CC(1)=CC(1)+1	76
	GO TO 25	77
34	CHC=CHC+1	78
	EMC=EMC+ERRC	79
	MSQC=MSQC+ERRC**2	80
	GO TO 25	81
35	M=(ERRC-ERMAX)/DEL	82
	M=M+LH	83
	IF (M-LH) 36,36,37	84
36	CC(M)=CC(M)+1	85
	GO TO 25	86
37	CPC=CPC+1	87
	EPC=EPC+ERRC	88
	PSQC=PSQC+ERRC**2	89
	GO TO 25	90
38	AERNCC=SUMNC/NNC	91
39	AERRC=SUMC/NC	92
	VARNC=(SQNC-NNC*AERNCC**2)/(NNC-1)	93
	VARC=(SQC-NC*AERRC**2)/(NC-1)	94
	SDNC=SQRTF(VARNC)	95
	SDC=SQRTF(VARC)	96
	PENC=0,6745*SDNC	97
	PEC=0,6745*SDC	98
	COFNC=1,96*SDNC	99
	CONFNC=1,96*SDC	100
	IF (LCALO-10) 40,41,42	101
40	WRITE (61,7)	102
	WRITE (61,8) NNC,AERNCC,VARNC,SDNC,PENC,COFNC	103
	GO TO 43	104
41	WRITE (61,7)	105
	WRITE (61,8) NNC,AERNCC,VARNC,SDNC,PENC,COFNC	106
42	WRITE (61,9)	107
	WRITE (61,10) NC,AERRC,VARC,SDC,PEC,CONFNC	108
43	WRITE (61,11)	109
	FCMNC=CHNC/N	110
	FCPNC=CPNC/N	111
	FCMC=CHC/N	112
	FCPC=CPC/N	113

IF (LCALO-10) 44,45,46	114
44 WRITE (61,12) CMNC,FCMNC,CPNC,FCPNC	115
GO TO 47	116
45 WRITE (61,12) CMNC,FCMNC,CPNC,FCPNC	117
46 WRITE (61,13) CMC,FCMC,CPC,FCPC	118
47 IF (LCALO-10) 48,48,51	119
48 WRITE (61,14)	120
M=1	121
APNC=100*FCMNC	122
49 Y=ERMIN+(M-1)*DEL	123
PCNC=100*C(M)/NMC	124
APNC=APNC+PCNC	125
WRITE (61,69) Y	126A
WRITE (61,15) C(M),PCNC,APNC	126
M=M+1	127
IF (M-1-LH) 49,49,50	128
50 IF (LCALO-10) 53,51,51	129
51 WRITE (61,16)	130
M=1	131
APC=100*FCMC	132
52 YC=ERMIN+(M-1)*DEL	133
PCC=100*CC(M)/NC	134
APC=APC+PCC	135
WRITE (61,70) YC	136A
WRITE (61,17) CC(M),PCC,APC	136
M=M+1	137
IF (M-1-LH) 52,52,53	138
53 IF (B) 59,54,59	139
54 WRITE (61,18)	140
WRITE (61,19)	141
NCALL=1	142
55 IF (D(NCALL)) 57,57,56	143
56 WRITE (61,20) NCALL,D(NCALL)	144
57 NCALL=NCALL+1	145
IF (NCALL-LD) 55,55,58	146
58 WRITE (61,21)	147
59 IF (B) 60,60,62	148
60 B=1	149
IF (CMNC+CPNC) 70,62,70	
70 IF (MOD) 62,61,62	
61 SQNC=SQNC-MSQNC-PSQNC	150
SQC=SQC-MSQC-PSQC	151
NMC=N-CPNC-CMC	152
NC=N-CPC-CMC	153
SUMNC=SUNNC-EMNC-EPNC	154
SUMC=SUMC-EMC-EPC	155
CPNC=CMNC=CPC=CMC=0	156
WRITE (61,22)	157
GO TO 38	158
62 CONTINUE	159
IF (TB-500) 64,65,64	
65 CONTINUE	
END	160
SCOPE	

DOCUMENT CONTROL DATA - R&D		
<i>(Security classification of title, body of abstract and indexing annotation must be entered when the overall report is classified)</i>		
1. ORIGINATING ACTIVITY (Corporate author) Southwest Research Institute 8500 Culebra Road San Antonio, Texas 78228		2a. REPORT SECURITY CLASSIFICATION Unclassified
		2b. GROUP
3. REPORT TITLE Use of the Beverage Antenna in Wide Aperture High Frequency Direction Finding		
4. DESCRIPTIVE NOTES (Type of report and inclusive dates) Final Report, Volume I--Research and Development		
5. AUTHOR(S) (Last name, first name, initial) Martin, Paul E. Dodge, Carl		
6. REPORT DATE 15 September 1967	7a. TOTAL NO. OF PAGES 67 + 179 pp. Appendixes	7b. NO. OF REFS 10
8a. CONTRACT OR GRANT NO. NObsr-89345	8b. ORIGINATOR'S REPORT NUMBER(S) None	
b. PROJECT NO. SF 0010805		
c. Task 9094	9b. OTHER REPORT NO(S) (Any other numbers that may be assigned to report) None	
10. AVAILABILITY/LIMITATION NOTICES Qualified requesters may obtain copies of this report from DDC.		
11. SUPPLEMENTARY NOTES None	12. SPONSORING MILITARY ACTIVITY Naval Electronics Systems Command Baileys Crossroads, Virginia 22041	
13. ABSTRACT Four years of research and development concerning the use of the Beverage antenna for high frequency radio direction finding are summarized in this two-volume final report. Volume I concerns all design details. Bearing accuracy tests on several configurations of circular arrays of 75-meter long elements are described in Volume II. A computer programmed general theory of the Beverage antenna has been completed to calculate azimuth and elevation element and array patterns as a function of antenna length, height above ground, array size, frequency, earth constants, phasing and many other parameters. Verifying experimental measurements are also reported. The development of a Wullenweber-type scan digital commutator to permit extreme flexibility in arraying of any number of Beverage antennas with any array spacing has been completed. The present digital commutator design has demonstrated reduction in switching transients below system noise levels, good element to element isolation, satisfactory gain in each antenna circuit, and predicted array gains. Design details for an electronic digital commutator (no rotating parts) have been completed. The present design is a suitable basis for control and programming by digital computer in a real time adaptive system. Research results have shown the value of Beverage antennas as a low cost element in wideband circular wide aperture HF DF arrays over soils of relatively either low or high conductivity. The antenna is essentially frequency independent with		

14. KEY WORDS	LINK A		LINK B		LINK C	
	ROLE	WT	ROLE	WT	ROLE	WT
Radio Direction Finding Beverage Antennas Traveling Wave Antennas Wide Aperture Antenna Arrays Digital Commutations Electronic Goniometers						

INSTRUCTIONS

1. **ORIGINATING ACTIVITY:** Enter the name and address of the contractor, subcontractor, grantee, Department of Defense activity or other organization (*corporate author*) issuing the report.
- 2a. **REPORT SECURITY CLASSIFICATION:** Enter the overall security classification of the report. Indicate whether "Restricted Data" is included. Marking is to be in accordance with appropriate security regulations.
- 2b. **GROUP:** Automatic downgrading is specified in DoD Directive 5200.10 and Armed Forces Industrial Manual. Enter the group number. Also, when applicable, show that optional markings have been used for Group 3 and Group 4 as authorized.
3. **REPORT TITLE:** Enter the complete report title in all capital letters. Titles in all cases should be unclassified. If a meaningful title cannot be selected without classification, show the classification in all capitals in parentheses immediately following the title.
4. **DESCRIPTIVE NOTES:** If appropriate, enter the type of report, e.g., interim, progress, summary, annual, or final. Give the inclusive dates when a specific reporting period is covered.
5. **AUTHOR(S):** Enter the name(s) of author(s) as shown on or in the report. Enter last name, first name, middle initial. If military, show rank and branch of service. The name of the principal author is an absolute minimum requirement.
6. **REPORT DATE:** Enter the date of the report as day, month, year, or month, year. If more than one date appears on the report, use date of publication.
- 7a. **TOTAL NUMBER OF PAGES:** The total page count should follow normal pagination procedures, i.e., enter the number of pages containing information.
- 7b. **NUMBER OF REFERENCES:** Enter the total number of references cited in the report.
- 8a. **CONTRACT OR GRANT NUMBER:** If appropriate, enter the applicable number of the contract or grant under which the report was written.
- 8b, 8c, & 8d. **PROJECT NUMBER:** Enter the appropriate military department identification, such as project number, subproject number, system numbers, task number, etc.
- 9a. **ORIGINATOR'S REPORT NUMBER(S):** Enter the official report number by which the document will be identified and controlled by the originating activity. This number must be unique to this report.
- 9b. **OTHER REPORT NUMBER(S):** If the report has been assigned any other report numbers (*either by the originator or by the sponsor*), also enter this number(s).
10. **AVAILABILITY/LIMITATION NOTICES:** Enter any limitations on further dissemination of the report, other than those

imposed by security classification, using standard statements such as:

- (1) "Qualified requesters may obtain copies of this report from DDC."
- (2) "Foreign announcement and dissemination of this report by DDC is not authorized."
- (3) "U. S. Government agencies may obtain copies of this report directly from DDC. Other qualified DDC users shall request through _____."
- (4) "U. S. military agencies may obtain copies of this report directly from DDC. Other qualified users shall request through _____."
- (5) "All distribution of this report is controlled. Qualified DDC users shall request through _____."

If the report has been furnished to the Office of Technical Services, Department of Commerce, for sale to the public, indicate this fact and enter the price, if known.

11. **SUPPLEMENTARY NOTES:** Use for additional explanatory notes.
12. **SPONSORING MILITARY ACTIVITY:** Enter the name of the departmental project office or laboratory sponsoring (*paying for*) the research and development. Include address.
13. **ABSTRACT:** Enter an abstract giving a brief and factual summary of the document indicative of the report, even though it may also appear elsewhere in the body of the technical report. If additional space is required, a continuation sheet shall be attached.

It is highly desirable that the abstract of classified reports be unclassified. Each paragraph of the abstract shall end with an indication of the military security classification of the information in the paragraph, represented as (TS), (S), (C), or (U).

There is no limitation on the length of the abstract. However, the suggested length is from 150 to 225 words.

14. **KEY WORDS:** Key words are technically meaningful terms or short phrases that characterize a report and may be used as index entries for cataloging the report. Key words must be selected so that no security classification is required. Identifiers, such as equipment model designation, trade name, military project code name, geographic location, may be used as key words but will be followed by an indication of technical context. The assignment of links, rules, and weights is optional.

ABSTRACT (Cont'd)

Page 2

an endfire unidirectional aperiodic pattern throughout the 1 to 30-MHz range. The input impedance, almost totally resistive and uniformly flat over the frequency range of interest, can be easily transformed to any standard feed cable impedance with a standing wave ratio of less than 1.25/1. Antenna dimensions need not exceed one wavelength long or one meter above ground. For a fixed size array, reduced beamwidth and increased sensitivity is obtained with short antennas and a large feedpoint radius rather than long antennas with a short feedpoint radius. Evaluation of the antenna in direction finder performance using circular arrays including simultaneous comparison with an AN/TRD-15 Doppler system is reported. Bearing accuracy tests show performance comparable to the AN/TRD-15 in that, at times, one system then the other exhibited more favorable accuracy performance. Standard deviations obtained in certain samples were below 2°, but most were in the range of 2° to 3° with a few higher consistent with previous reporting. DF bearing sensitivities exceed that of the AN/TRD-15. Delivery of the developed transportable Beverage direction finder to the U. S. Army including instruction and maintenance manual is reported.