

UNCLASSIFIED

AD NUMBER

AD821534

LIMITATION CHANGES

TO:

Approved for public release; distribution is unlimited.

FROM:

Distribution authorized to U.S. Gov't. agencies and their contractors; Critical Technology; OCT 1967. Other requests shall be referred to Arnold Engineering Development Center, Arnold Air Force Station, TN 37389. This document contains export-controlled technical data.

AUTHORITY

AEDC ltr, 12 Dec 1969

THIS PAGE IS UNCLASSIFIED

AEDC-TR-67-175

**ARCHIVE COPY
DO NOT LOAN**

Cy 1



DEVELOPMENT OF A LASER VELOCIMETER SYSTEM

J. I. Shipp, R. H. Hines, and W. A. Dunnill

ARO, Inc.

October 1967

~~This document is subject to special export controls and each transmittal to foreign governments or foreign nationals may be made only with prior approval of Arnold Engineering Development Center (AETS), Arnold Air Force Station, Tennessee.~~

This document has been approved for public release and sale; its distribution is unlimited.

per AF letter, 12 Dec 69, signed William Q. Cole, AETS

**ARNOLD ENGINEERING DEVELOPMENT CENTER
AIR FORCE SYSTEMS COMMAND
ARNOLD AIR FORCE STATION, TENNESSEE**

PROPERTY OF U S AIR FORCE
AEDC LIBRARY
AF 40(600)1200

AEDC TECHNICAL LIBRARY



1995 TE000 0210 5

NOTICES

When U. S. Government drawings specifications, or other data are used for any purpose other than a definitely related Government procurement operation, the Government thereby incurs no responsibility nor any obligation whatsoever, and the fact that the Government may have formulated, furnished, or in any way supplied the said drawings, specifications, or other data, is not to be regarded by implication or otherwise, or in any manner licensing the holder or any other person or corporation, or conveying any rights or permission to manufacture, use, or sell any patented invention that may in any way be related thereto.

Qualified users may obtain copies of this report from the Defense Documentation Center.

References to named commercial products in this report are not to be considered in any sense as an endorsement of the product by the United States Air Force or the Government.

DEVELOPMENT OF A
LASER VELOCIMETER SYSTEM

J. I. Shipp, R. H. Hines, and W. A. Dunnill
ARO, Inc.

~~This document is subject to special export controls and such transmittal to foreign governments or foreign nationals may be made only with prior approval of Arnold Engineering Development Center (AEDC), Arnold Air Force Station, Tennessee.~~

This document has been approved for public release and sale; its distribution is unlimited.

*per AF letter, 12 Dec 69, signed William D. Cole
AETS*

FOREWORD

The work reported herein was sponsored by the Arnold Engineering Development Center (AEDC), Air Force Systems Command (AFSC), Arnold Air Force Station, Tennessee, under Program Element 6540223F.

The results of research were obtained by ARO, Inc. (a subsidiary of Sverdrup & Parcel and Associates, Inc.), contract operator of AEDC, AFSC, under Contract AF40(600)-1200. The work was conducted under ARO Project No. BC3713 from July 1966 to June 1967. The manuscript was submitted for publication on August 2, 1967.

Information in this report is embargoed under the Department of State International Traffic in Arms Regulations. This report may be released to foreign governments by departments or agencies of the U. S. Government subject to approval of the Arnold Engineering Development Center (AETS), or higher authority within the Department of the Air Force. Private individuals or firms require a Department of State export license.

This technical report has been reviewed and is approved.

Marshall Kingery
Research Division
Directorate of Plans and
Technology

Edward R. Feicht
Colonel, USAF
Director of Plans and
Technology

ABSTRACT

The development of a laser velocimeter for point velocity measurements in liquid and gas flows is discussed. The principle of operation of the velocimeter is based on the Doppler effect, and the velocity measurements are accomplished by an optical homodyning technique. Velocity profiles are presented for laminar flow of water and air in circular flow channels. It was found that a correction factor was required when measuring velocities of fluids having indices of refraction different from air. The velocimeter is shown to be capable of velocity measurements of a vibrating surface.

~~This document is subject to special export controls and such transmittal to foreign governments or foreign nationals may be made only with prior approval of Arnold Engineering Development Center (AEDC), Arnold Air Force Station, Tennessee.~~

This document has been approved for public release
and sale; its distribution is unlimited.
per AF letter 12 Dec 64 Signed William D. Cole
AETS

CONTENTS

	<u>Page</u>
ABSTRACT.	iii
NOMENCLATURE.	vi
I. INTRODUCTION	1
II. THEORY OF OPERATION	
2.1 Derivation of the Doppler Equation	2
2.2 Derivation of the Optical Homodyne Equation.	3
III. EXPERIMENTAL ARRANGEMENTS	
3.1 Vibrating Mirror Experiment	4
3.2 Liquid Velocity Measurements	5
3.3 Gas Velocity Measurements	7
IV. CONCLUSION.	7
REFERENCES	8

APPENDIX

Illustrations

Figure

1. Schematic Diagram of a Typical Laser Velocimeter System.	11
2. Angle Definitions for Doppler Effect Calculation	12
3. Optical System for the Vibrating Mirror Experiment	13
4. Oscillogram of the Vibrating Mirror Signal	14
5. Spectrogram of the Vibrating Mirror Signal	15
6. Schematic Diagram of Liquid Flow System.	16
7. Traverse Table Arrangement.	17
8. Typical Spectrogram from the Water Velocity Measurements	18
9. Typical Photomultiplier Output Signal	19
10. Velocity Profile of Water in a Circular Pipe	20
11. Geometry for Correction Factor Calculation	21
12. Correction Factor versus Scattering Angle.	22
13. Flow System for Velocity Measurements in Air.	23

<u>Figure</u>		<u>Page</u>
14.	Typical Spectrogram from the Air Velocity Measurements.	24
15.	Velocity Profile of Air in a Circular Pipe	25

NOMENCLATURE

A	Magnitude of the incident beam wave function
\AA	Angstrom
B	Magnitude of the scattered beam wave function
c	Velocity of light
D	Diameter of flow channel
\bar{F}	Poynting flux
f_D	Doppler frequency, Hz
i	$(-1)^{1/2}$
k_D	$k_S - k_O$
k_O	Magnitude of \bar{k}_O
\bar{k}_O	Wave vector of the incident laser radiation in S
\bar{k}'_O	Wave vector of the incident laser radiation in S'
$k_{O\mu}$	Four-component wave vector of the incident laser radiation in S
$k'_{O\mu}$	Four-component wave vector of the incident laser radiation in S'
k_S	Magnitude of \bar{k}_S
\bar{k}_S	Wave vector of the scattered laser radiation in S
\bar{k}'_S	Wave vector of the scattered laser radiation in S'
$k_{S\mu}$	Four-component wave vector of the scattered laser radiation in S
$k'_{S\mu}$	Four-component wave vector of the scattered laser radiation in S'
n	Index of refraction
R	Radius of the flow channel

r	Distance from centerline in the flow channel
S	Fixed laboratory reference frame
S'	Reference frame moving with velocity \bar{V} relative to S
t	Time
V	Magnitude of \bar{V}
\bar{V}	Velocity in S
\bar{V}'	Velocity in S'
V_m	Maximum velocity in S
V_μ	Four-vector velocity in S
V'_μ	Four-vector velocity in S'
$\langle V \rangle$	Average velocity in S
\dot{W}	Volumetric flow rate
X	Distance along flow channel subtended by θ
x	Magnitude of wave position vector
y	Contracted flow channel diameter
α	Angle between unscattered and scattered light in Fig. 11
β	Angle between the velocity vector and the scattered light in Fig. 3
γ	$\left[1 - \left(\frac{V}{c} \right)^2 \right]^{1/2}$
Δ	Area
θ	Angle between the incident and scattered light in Figs. 2 and 11
ψ	Angle between the velocity vector and the incident light in Fig. 2
Φ_T	Incident beam wave function
Φ_S	Scattered beam wave function
λ_0	Wavelength of emitted laser radiation
ω_D	Doppler frequency, radians/sec
ω_g	Generator frequency driving the speaker
ω_0	Frequency of incident laser radiation in S
ω'_0	Frequency of incident laser radiation in S'
ω_S	Frequency of scattered laser radiation in S
ω'_S	Frequency of scattered laser radiation in S'

SECTION I INTRODUCTION

The first laser velocimeter (LV) constructed by Yeh and Cummings (Ref. 1) at Columbia University was used to measure velocities of the order of 10^{-4} m/sec. Later Foreman, George, and Lewis (Ref. 2) constructed an LV which was capable of measuring gas velocities from 10^{-2} to 10^2 m/sec.

The original purpose of developing the laser velocimeter at the AEDC was to study flow fields of low speed V/STOL aircraft. Since the developmental plan was established, however, interest has arisen also in the high speed regime encountered in shock tubes and in jet plume studies, and at present, theoretical effort is being focused on these problems. Simultaneously, experiments have been initiated in measuring very low speed boundary-layer velocities in electrically conducting fluids of MHD flow channels. Because of the wide range of possible applications of this instrument, the objective of this program is to define the repeatability and resolution of the instrument and to extend the range from a few tenths of a centimeter per second to about 10^4 m/sec.

The use of the LV for point velocity measurements has many advantages over conventional measuring techniques. The flow field is not measurably perturbed by the LV, since only a minute amount of the low power laser beam is absorbed by the fluid. The size of the focal point of a focused laser beam can be as small as a few microns indicating that the spatial resolution of the LV is typically of the order of a few microns. Also, the response of the LV is linear over the entire velocity range of interest in normal fluid flow studies. The range of velocities capable of being measured by the laser technique is limited by the frequency response of the readout instrumentation. Velocity measurements from a small fraction of a centimeter per second to 10^3 m/sec are currently possible. The extension of the upper range by two orders of magnitude appears theoretically possible. The LV has the added capability of measuring rapidly varying velocities which are experienced in fully developed turbulence at Reynolds numbers greater than 10^5 (Ref. 3).

SECTION II THEORY OF OPERATION

The principle of operation of the laser velocimeter is based on the Doppler effect. A schematic diagram of the LV system is shown in Fig. 1 (Appendix). Light emitted from the laser is focused to a point in the flowing

fluid by means of lens L_1 . From this point, a small portion of the beam is scattered through the angle θ . This scattered light is shifted in frequency because of the Doppler effect and is focused by lens L_2 . The frequency shifted light is then incident upon a front surface mirror M_1 , reflected through the beam splitter, and focused on the photocathode surface. The unscattered portion of the laser beam is focused by lens L_3 , attenuated by a neutral density filter, transmitted through the beam splitter, reflected at the front surface mirror M_2 , and rotated 90 deg by the beam splitter so that it becomes incident on the photocathode surface. The paths of both beams between the beam splitter and the photocathode must be coincidental. At the photocathode surface, the two beams are optically homodyned to obtain the Doppler frequency. Hence, the frequency detected by the photomultiplier is proportional to the velocity at the scattering point.

2.1 DERIVATION OF THE DOPPLER EQUATION

Consider a scattering center fixed in a reference frame S' which has a velocity \bar{V} relative to a laboratory fixed frame of reference S . A light source of frequency ω_0 and wave vector \bar{k}_0 in S will appear as ω'_0 and \bar{k}'_0 in S' . The incident light is scattered by the scattering center in S' . The angular frequency of the scattered light is identical to the incident light as viewed in S' , i. e.

$$\omega_0' \equiv \omega_s' \quad (1)$$

To obtain the Doppler shift frequency, ω_D , the frequency of the scattered light must be calculated in the laboratory system, S , where ω_D is defined as

$$\omega_D' \equiv \omega_s - \omega_0 \quad (2)$$

Use is made of the invariance of scalar products of four vectors, where the following quantities transform as four vectors:

$$\begin{aligned} k_{0\mu} &= (\bar{k}_0, i \frac{\omega_0}{c}) \\ k'_{0\mu} &= (\bar{k}'_0, i \frac{\omega'_0}{c}) \\ k_{s\mu} &= (\bar{k}_s, i \frac{\omega_s}{c}) \\ k'_{s\mu} &= (\bar{k}'_s, i \frac{\omega'_s}{c}) \\ V_\mu &= (\gamma\bar{V}, i\gamma c) \\ V'_\mu &= (\gamma\bar{V}', i\gamma c) = (0, i\gamma c) \end{aligned} \quad (3)$$

where

$$i = (-1)^{\mu/2} \quad \mu = 1, 2, 3, 4$$

and

$$c = \text{velocity of light}$$

$$\gamma = [1 - (v/c)^2]^{-1/2}$$

Since four-vector scalar products are invariant,

$$k_{o\mu} V_{\mu} = k_{o\mu'} V_{\mu'} \quad (4)$$

and

$$k_{s\mu} V_{\mu} = k_{s\mu'} V_{\mu'} \quad (5)$$

where the Einstein summation convention has been employed. Substitution of the definitions in Eq. (3) into Eqs. (4) and (5) yields

$$k_{o\mu} V_{\mu} = -\omega_o \dot{\gamma} \quad (6)$$

and

$$k_{s\mu} V_{\mu} = -\omega_s \dot{\gamma} \quad (7)$$

Hence,

$$k_{o\mu} V_{\mu} = k_{s\mu} V_{\mu} \quad (8)$$

In three-vector form, Eq. (8) becomes

$$\gamma \bar{k}_o \cdot \bar{V} - \gamma \omega_o = \gamma \bar{k}_s \cdot \bar{V} - \gamma \omega_s \quad (9)$$

Equation (2) then leads to

$$\omega_D = (\bar{k}_s - \bar{k}_o) \cdot \bar{V} \quad (10)$$

Since

$$|\bar{k}_s| = |\bar{k}_o| = \frac{2\pi n}{\lambda_o}$$

and

$$f_D = \frac{\omega_D}{2\pi} \quad (11)$$

Equation (10) becomes

$$f_D = \frac{2nV}{\lambda_o} \sin\left(\frac{\theta}{2}\right) \sin\left(\psi + \frac{\theta}{2}\right) \quad (12)$$

where n is the index of refraction of the medium, λ_o is the wavelength of the emitted radiation, and θ and ψ are the angles defined in Fig. 2.

2.2 DERIVATION OF THE OPTICAL HOMODYNE EQUATION

In this section, a simplified derivation of the optical homodyne process is derived. The scattered and the transmitted beams are assumed to be aligned so that they leave the beam splitter at the same

point and are incident upon the same point of the photocathode. The wave functions for the transmitted and scattered beams are approximated by plane waves of the form

$$\Phi_T = A e^{ik_0 x - i\omega_0 t} \quad (13)$$

$$\Phi_S = B e^{i(k_0 + k_D)x - i(\omega_0 + \omega_D)t} \quad (14)$$

By the superposition theorem, the two wave functions add linearly. Hence,

$$\begin{aligned} \Phi = \Phi_T + \Phi_S &= A e^{ik_0 x - i\omega_0 t} + A e^{i(k_0 + k_D)x - i(\omega_0 + \omega_D)t} \\ &+ (B - A) e^{i(k_0 + k_D)x - i(\omega_0 + \omega_D)t} \end{aligned} \quad (15)$$

The photocathode current is proportional to the Poynting flux, time averaged over the optical period, which in turn is proportional to the real part of $\Phi^* \Phi$. Multiplication of Eq. (15) by its complex conjugate leads to

$$\bar{F} \approx \text{Re} (\Phi^* \Phi) = 2A^2 + 2A(B - A) + (B - A)^2 + 2AB \cos (k_D x - \omega_D t) \quad (16)$$

From Eq. (16), it is seen that photocathode tube current is composed of a constant or d-c term and an a-c term that varies at the Doppler angular frequency ω_D . The laser velocimeter measurement thus consists of measuring the frequency of a signal given by Eq. (16) and converting it to a velocity by Eq. (12).

SECTION III EXPERIMENTAL ARRANGEMENTS

During the course of development of the laser velocimeter, several experimental arrangements were used. First, a mirror was used as the moving scattering source. The mirror was attached to the cone of a loud speaker which was driven by a signal generator in simple harmonic motion. The experiment was designed to investigate optical alignment techniques and phototube response. Later, velocities of fluid media were studied under various flow conditions.

3.1 VIBRATING MIRROR EXPERIMENT

The optical system shown in Fig. 3 includes a scattering source moving in the simple harmonic motion of the speaker cone. Thus, the velocity component in the direction of the scattered light beam varies

sinusoidally. The time dependence of the velocity is given by Eq. (17).

$$V = V_m \cos(\omega_g t) \cos \beta \quad (17)$$

where ω_g is the generator frequency driving the speaker, and β is the angle between the velocity and the scattered beam. From Eqs. (12) and (16), it is seen that the phototube output should be a signal that is frequency modulated at the Doppler frequency at a modulation rate determined by the generator frequency. A typical oscillogram of the phototube output for a speaker frequency of 50 Hz is shown in Fig. 4. The end points of the harmonic oscillation are represented by the low frequency portion of the trace; and the point of maximum velocity, the equilibrium position of the oscillator, is represented by the high frequency portion of the trace. All frequencies corresponding to velocities from zero to $V_m \cos \beta$ are present in the homodyne signal as shown in the spectrogram of the signal in Fig. 5.

Since the results of the vibrating mirror studies indicated that the LV could be used for vibration studies, a diffuse aluminum surface was substituted for the quarter wave mirror. The results were comparable to those obtained in the mirror experiment with the exception that the amplitude of the output signal was lower because of the diffuse scattering from the aluminum surface.

3.2 LIQUID VELOCITY MEASUREMENTS

The LV was used to measure point velocities in water flow which was seeded with half-micron polystyrene latex spheres. The specific gravity of the seed particles is unity; therefore, settling of these particles in the chamber did not occur. A schematic diagram of the liquid flow system is shown in Fig. 6. In this particular series of experiments, the flow was laminar since the Reynolds number was always below 2000.

The optical system was mounted on a moveable table as shown in Fig. 7.

The system was traversed so that the focal point of the focusing lens moved across the flow channel diameter. The position of the optical table, and hence the position of the focal point relative to the tube walls, was determined to within 5×10^{-4} cm by a radial micrometer.

A typical oscillogram of the homodyne signal for laminar flow is shown in Fig. 8. The signal was amplified and filtered to remove high frequency noise. A typical spectrogram of the phototube output is shown in Fig. 9. The Doppler signal was 125 kHz as seen from the upper and

lower sideband frequencies of the spectrum analyzer. Data of this type were obtained at 0.025-cm increments along the tube diameter. A plot of the velocity profile obtained by this method at a point 1.3 m from the entrance area, defined in Fig. 6, is shown in Fig. 10. The solid line is the theoretically predicted parabolic velocity profile (see for example Ref. 4) of a fluid flowing in a smooth pipe in laminar flow as described by

$$\frac{v}{V_m} = 1 - \left(\frac{r}{R}\right)^2 \quad (18)$$

where R is the tube radius and V_m is the centerline velocity. The volumetric flow rate, \dot{W} , is related to the average velocity, $\langle V \rangle$, by

$$\dot{W} = \langle V \rangle \Delta \quad (19)$$

where Δ is the area of the tube, and $\langle V \rangle$ is obtained by integrating Eq. (18).

$$\langle V \rangle = V_m \frac{1}{\pi R^2} \int_0^{2\pi} \int_0^R \left[1 - \left(\frac{r}{R}\right)^2 \right] r dr d\Phi \quad (20)$$

yielding

$$\langle V \rangle = \frac{V_m}{2} \quad (21)$$

Substituting Eqs. (19) and (21) into (18) gives

$$v = \frac{2\dot{W}}{\Delta} \left[1 - \left(\frac{r}{R}\right)^2 \right] \quad (22)$$

For the experimental conditions $\psi = 90$ deg, $\theta = 10.3$ deg, $n = 1.33$ and $\lambda_0 = 6328$ Å, the centerline Doppler frequency was measured to be 24.5 kHz which corresponds to a V_m of 8.68 cm/sec. V_m calculated from Eq. (22) is 8.52 cm/sec. The error of 1.7 percent is well within the accuracy of the flow rate measurement.

When comparing the theoretical velocity profiles with experimentally measured values, a correction factor for the distance traversed is required because of the index of refraction of the fluid media. For fluid media with indices of refraction greater than that of air, the distance traversed by the focal point of the laser beam in the fluid appears contracted when compared to the actual distance that the optics are moved. This is seen by considering the geometry shown in Fig. 11.

The distance y traversed by the optical table is

$$y = \frac{X}{\tan \alpha} \quad (23)$$

where

$$X = \frac{D}{\tan \left(\frac{\pi}{2} - \theta\right)} \quad (24)$$

From Snell's law

$$n = \frac{\sin \alpha}{\sin \theta} \quad (25)$$

Thus the ratio of the table movement distance to the actual traverse distance in the medium, obtained by combining Eqs. (23), (24), and (25), is

$$\frac{y}{D} = \left\{ \tan \alpha \tan \left[\frac{\pi}{2} - \sin^{-1} \left(\frac{\sin \alpha}{n} \right) \right] \right\}^{-1} \quad (26)$$

For air flow n is equal to unity, and from Eq. (25) it can be shown that

$$\lim_{n \rightarrow 1} \left(\frac{y}{D} \right) = 1 \quad (27)$$

A plot of $\frac{y}{D}$ as a function of the scattering angle, α , (for water flow $n = 1.33$) is shown in Fig. 12. This correction factor was applied to the data in Fig. 10.

3.3 GAS VELOCITY MEASUREMENTS

The LV was used to measure point velocities in smoke seeded air under laminar flow conditions. The flow system used in the experiments is shown in Fig. 13. A typical spectrogram of the homodyne signal is shown in Fig. 14, and a plot of the measured velocity profile and the velocity profile calculated from Eq. (22) is shown in Fig. 15. Again the experimental agreement is within the accuracy of the measured flow rate.

SECTION IV CONCLUSION

The velocity of a vibrating mirror and point velocity measurements in water and gas laminar flows have been obtained using the LV. The data obtained for the fluid flows were experimentally verified by independent means. The velocity profiles of the two experiments were found to deviate by less than 5 percent from the theoretical curves, which is well within the experimental error involved with measuring the angles θ and ψ and the volumetric flow rate \dot{W} . Since the quantities n and λ_0 in Eq. (12) are accurately known, the accuracy of the LV is determined by the accuracy to which the angles θ and ψ can be measured.

Efforts are underway to measure velocity distributions at points in a fluid in fully developed turbulence. Coupled with this effort, a direct readout system for obtaining real time velocity measurements will also be developed. Plans call for extending the range of the LV velocity measurements to approximately 10^4 m/sec.

REFERENCES

1. Yeh, Y. and Cummins, H. Z. "Localized Fluid Flow Measurements with an He-Ne Laser Spectrometer." Applied Physics Letters, Vol. 4, No. 10, May 1964, pp. 176-178.
2. Foreman, J. W., Jr., George, E. W., and Lewis, R. D. "Measurements of Localized Flow Velocities in Gases with a Laser Doppler Flowmeter." Applied Physics Letters, Vol. 7, No. 77, 1965.
3. Welch, N. E. and Tomme, W. J. "The Analysis of Turbulence from Data Obtained with a Laser Velocimeter." AIAA Paper No. 67-179, January 1967.
4. Landau, L. D. and Lifshitz, E. M. Fluid Mechanics. Pergamon Press, London, 1959, p. 57.

**APPENDIX
ILLUSTRATIONS**

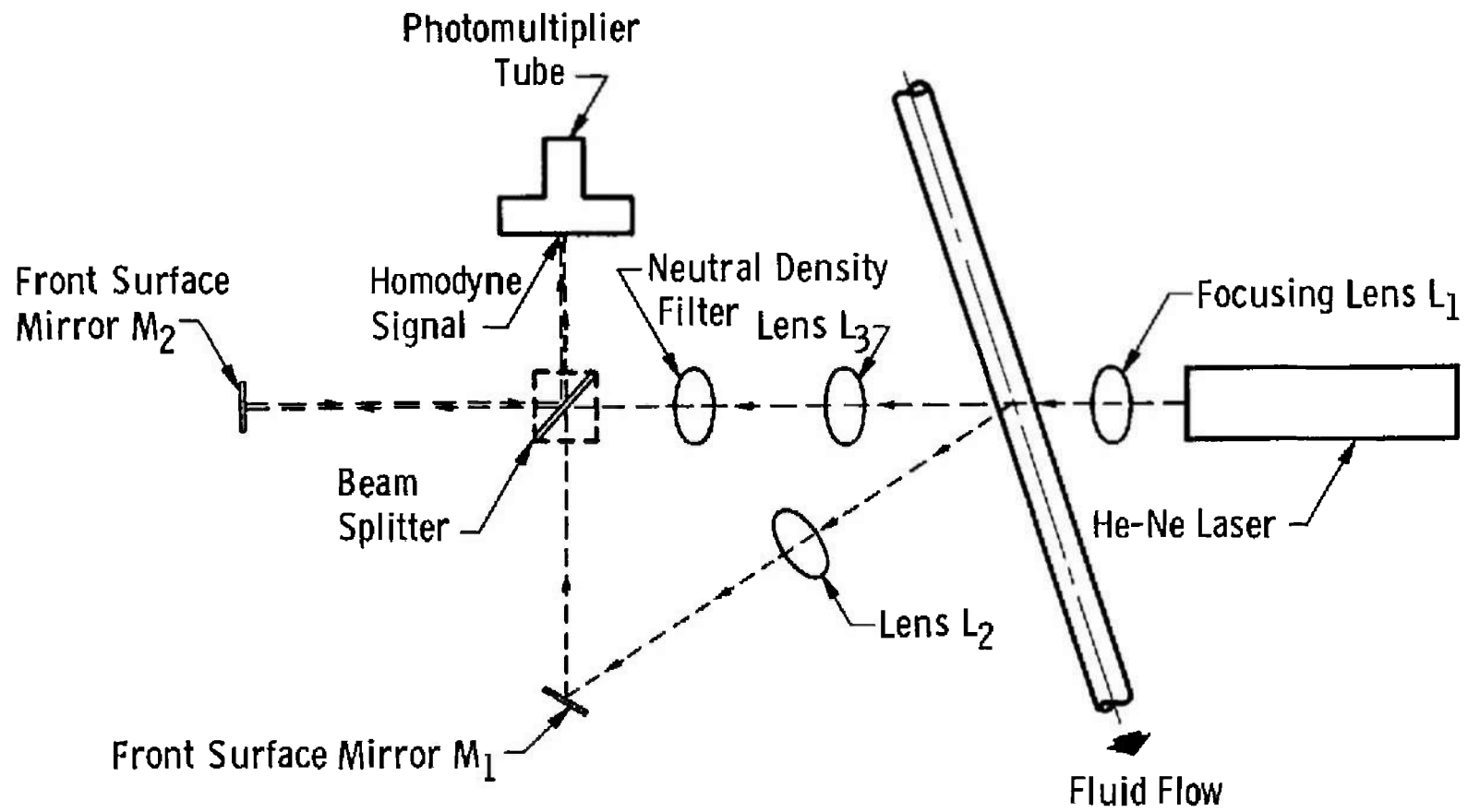

Fig. 1 Schematic Diagram of a Typical Laser Velocimeter System

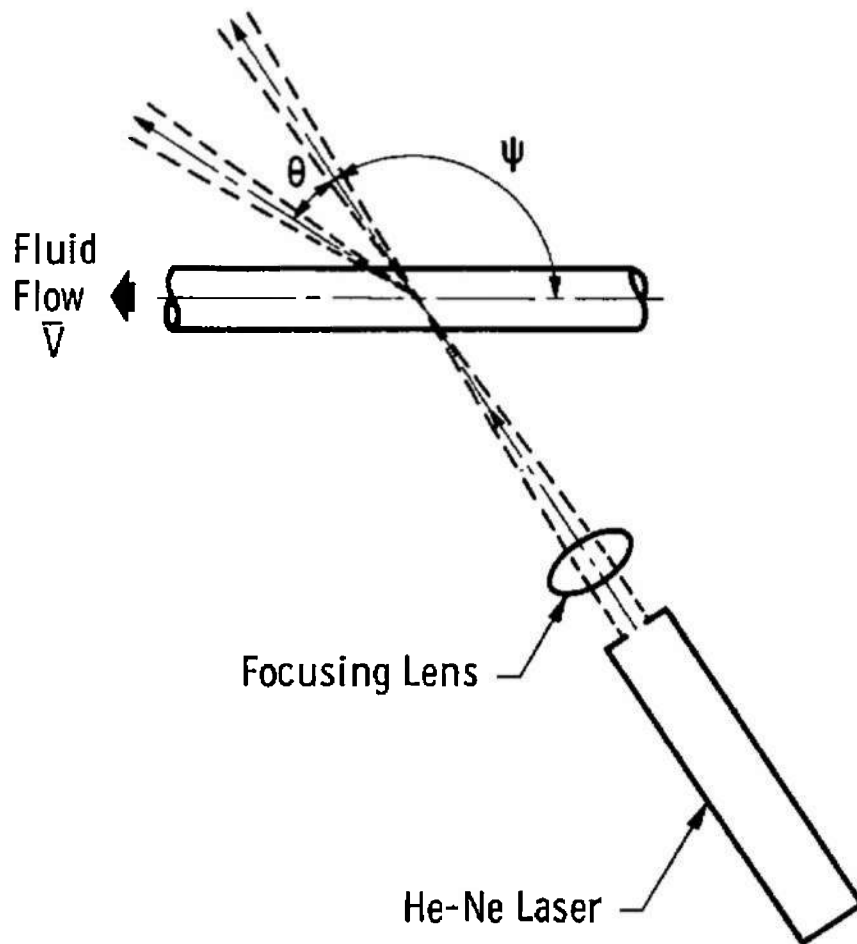

Fig. 2 Angle Definitions for Doppler Effect Calculation

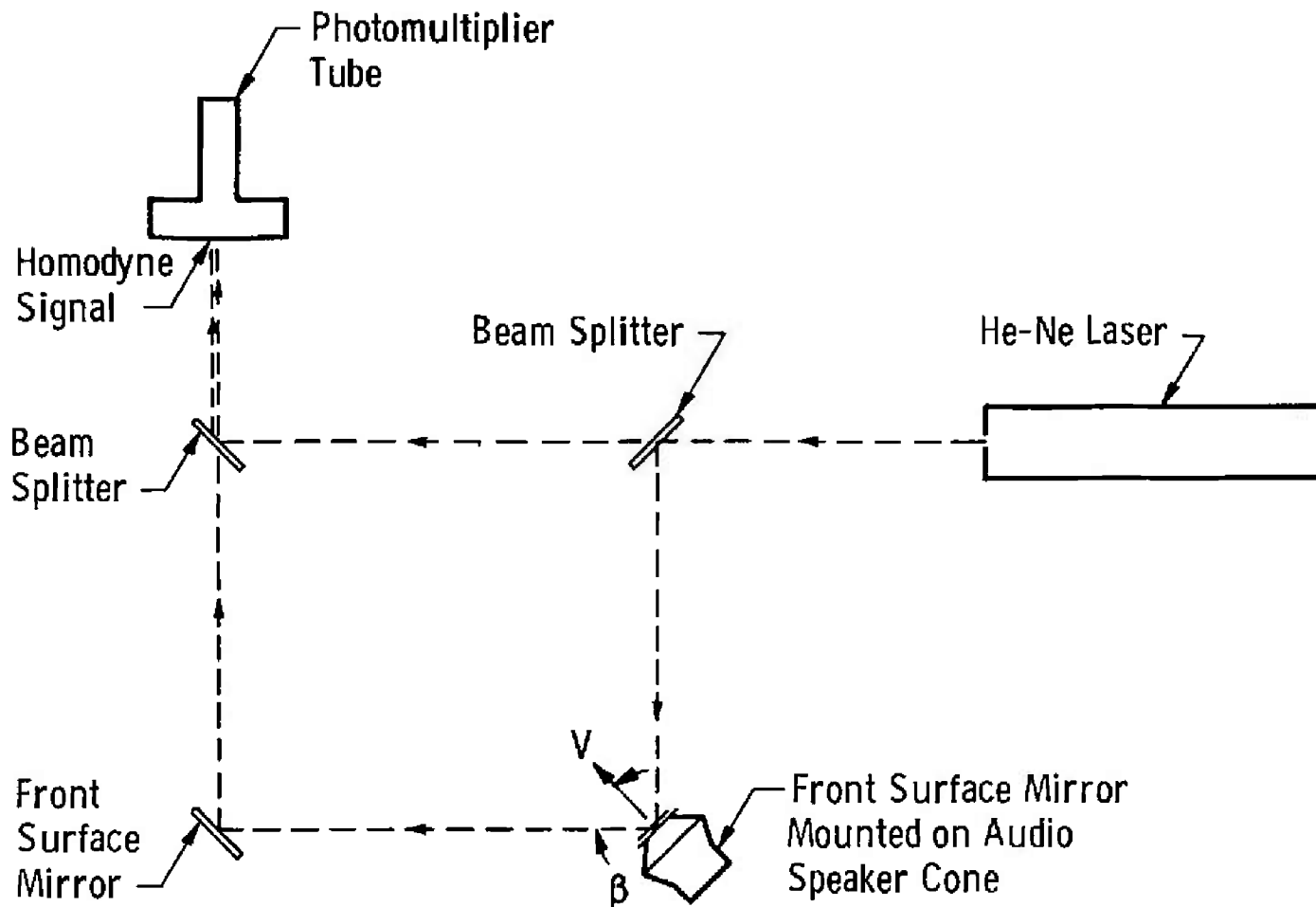
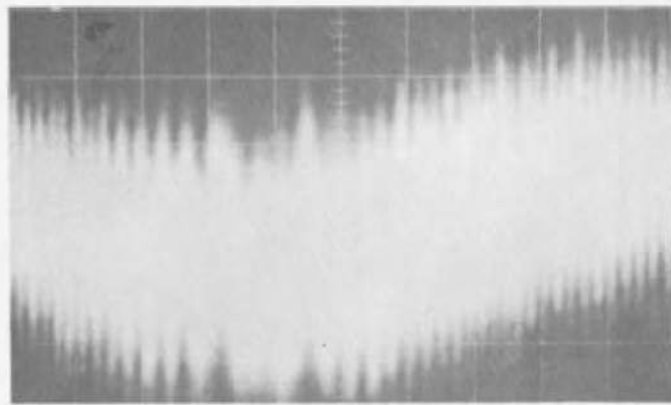

Fig. 3 Optical System for the Vibrating Mirror Experiment

1 v/cm



0.2 μ sec/cm

Fig. 4 Oscillogram of the Vibrating Mirror Signal

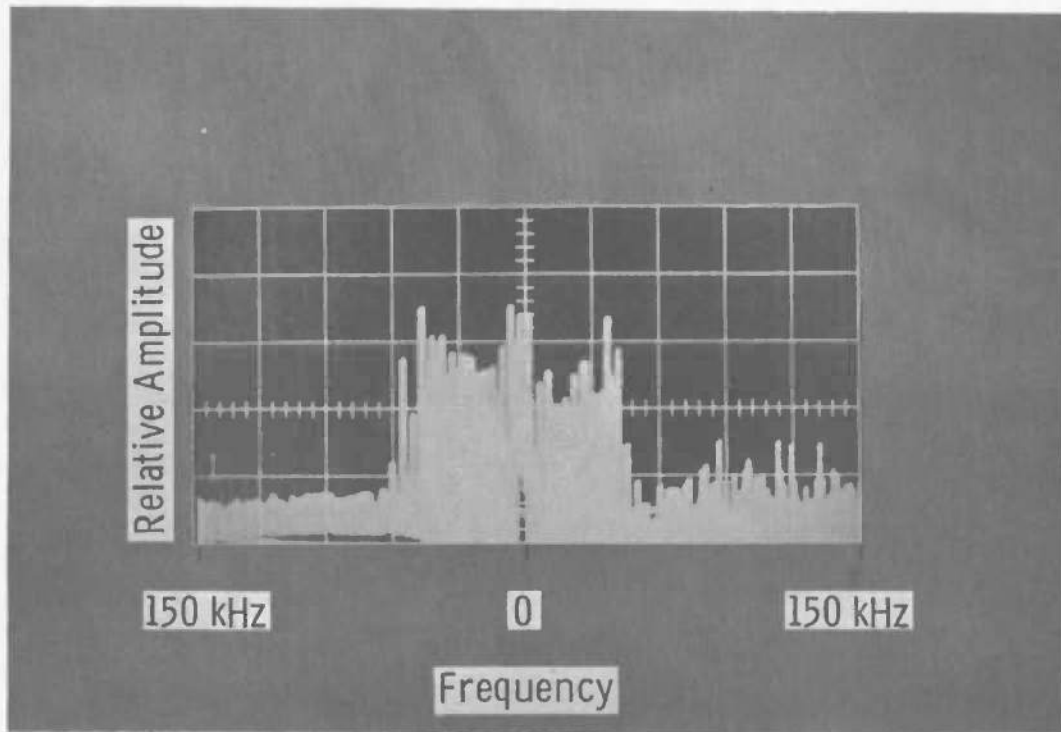

Fig. 5 Spectrogram of the Vibrating Mirror Signal

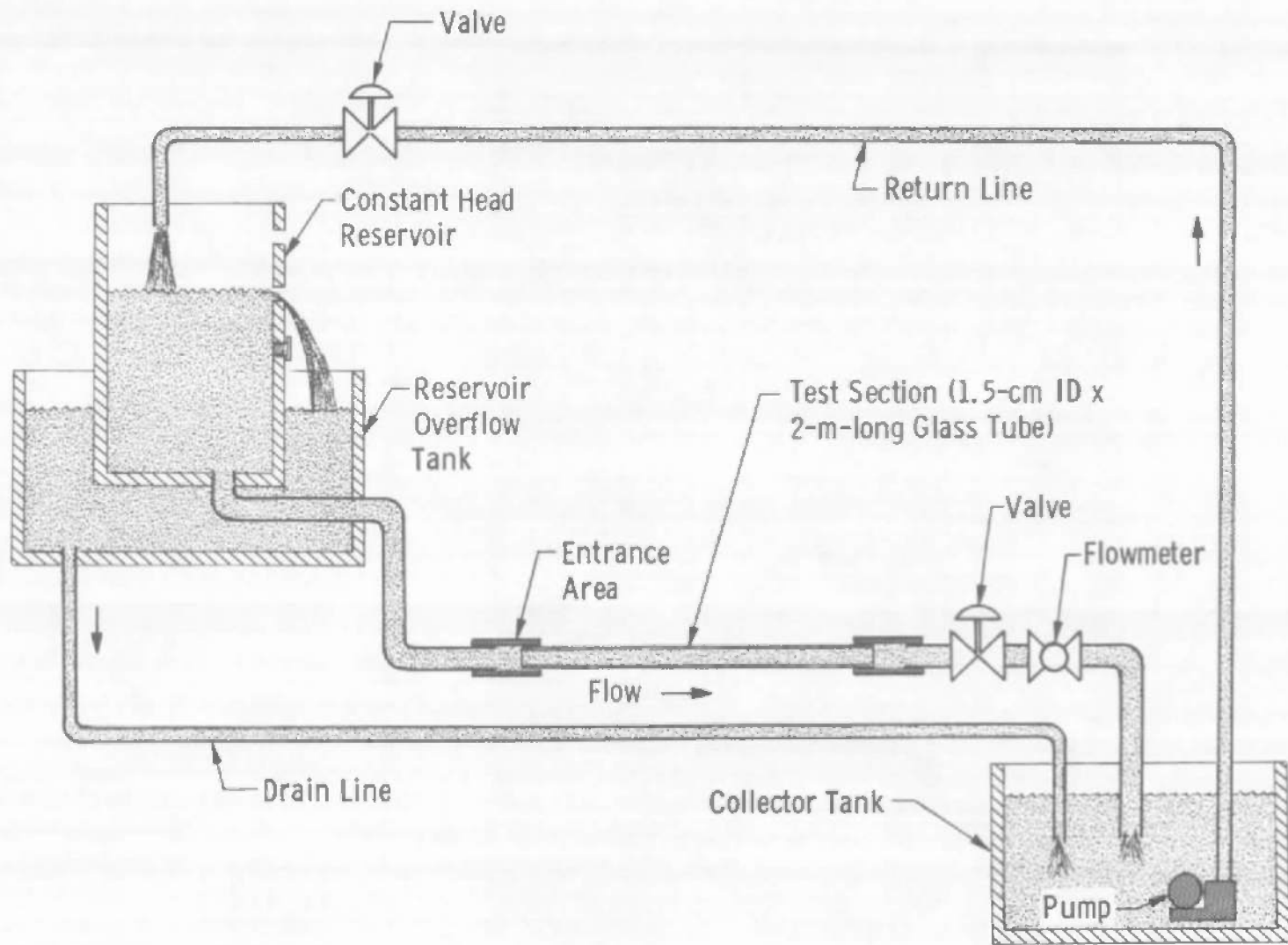

Fig. 6 Schematic Diagram of Liquid Flow System

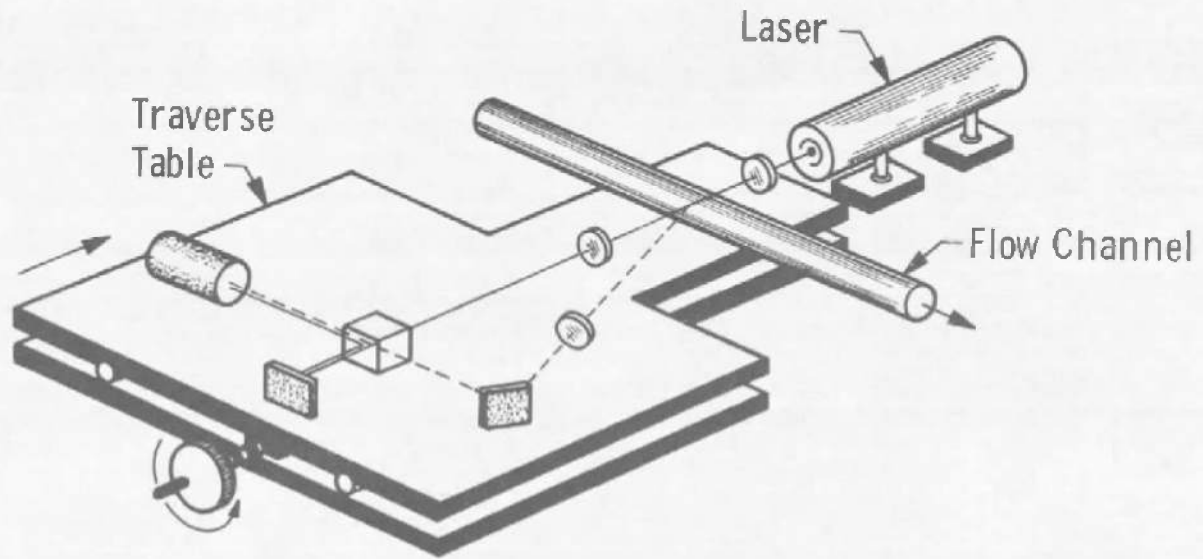

Fig. 7 Traverse Table Arrangement

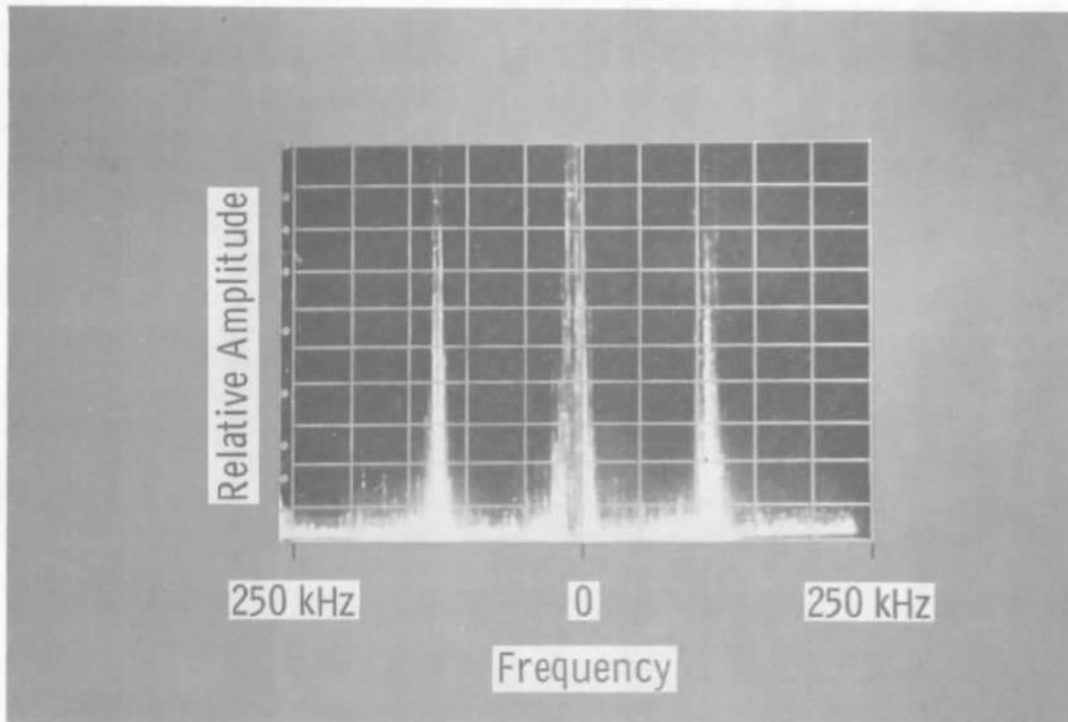

Fig. 8 Typical Spectrogram from the Water Velocity Measurements

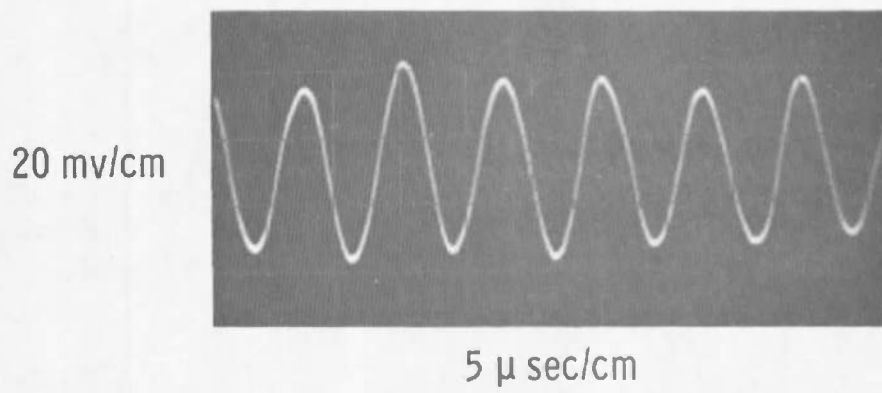

Fig. 9 Typical Photomultiplier Output Signal

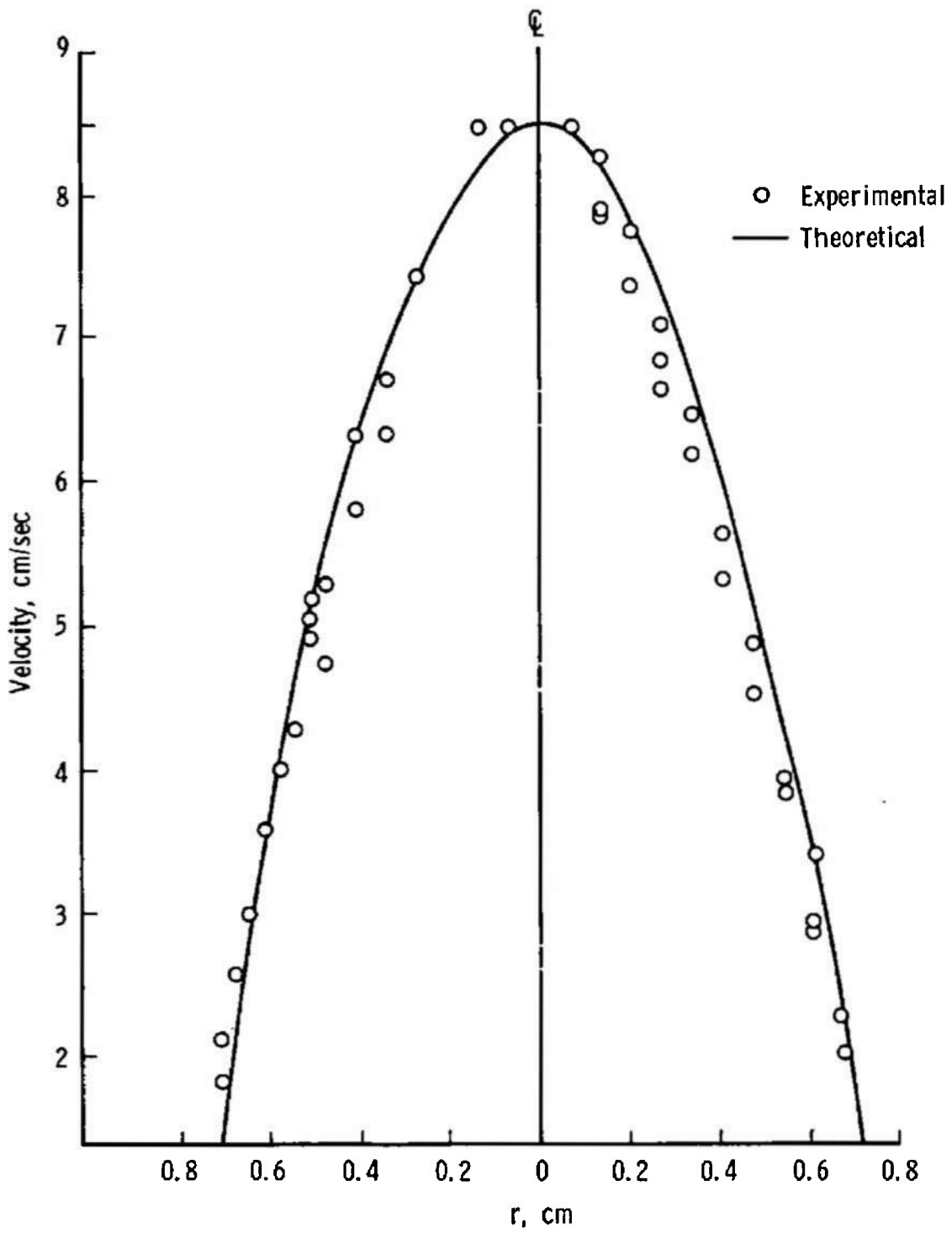

Fig. 10 Velocity Profile of Water in a Circular Pipe

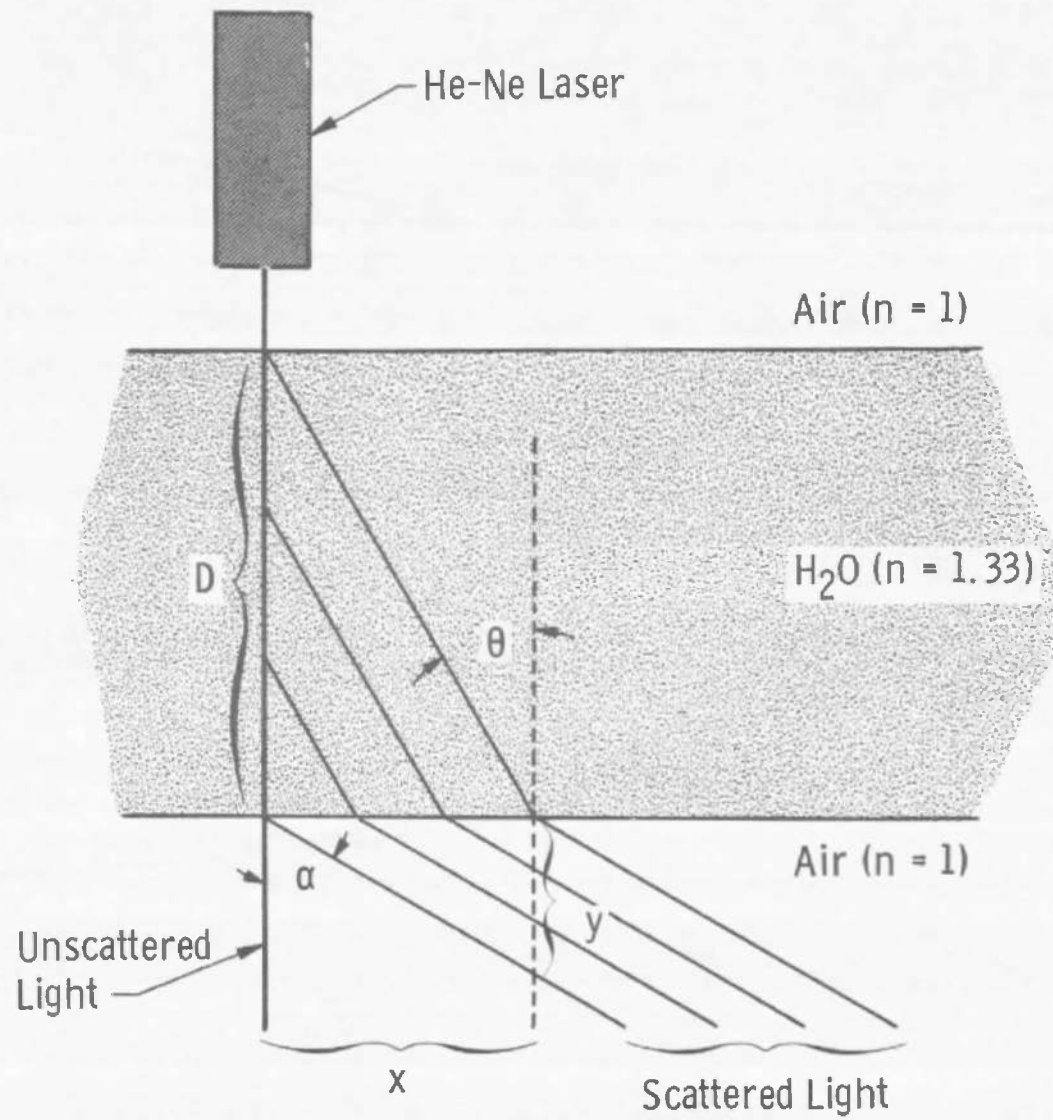

Fig. 11 Geometry for Correction Factor Calculation

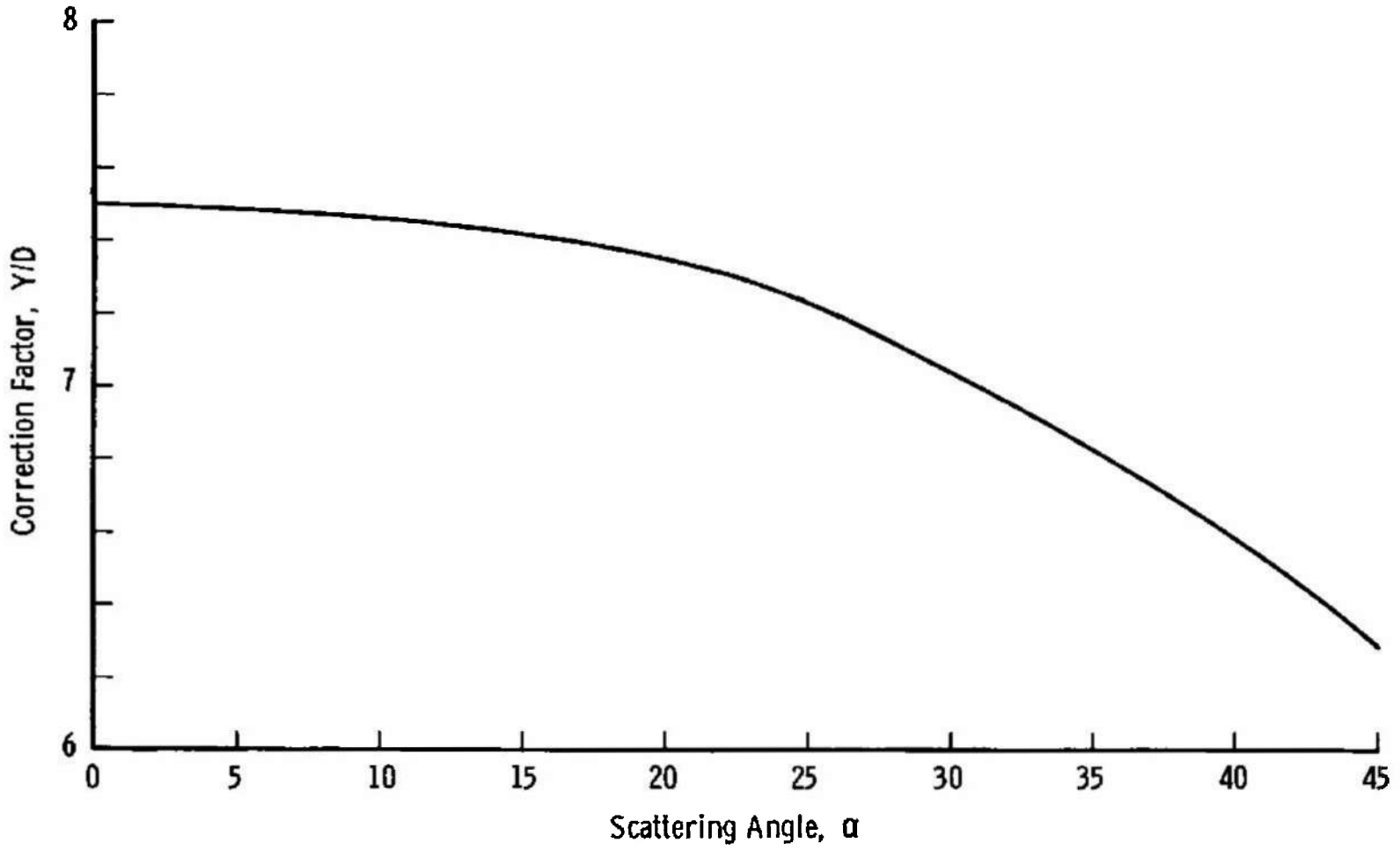

Fig. 12 Correction Factor versus Scattering Angle

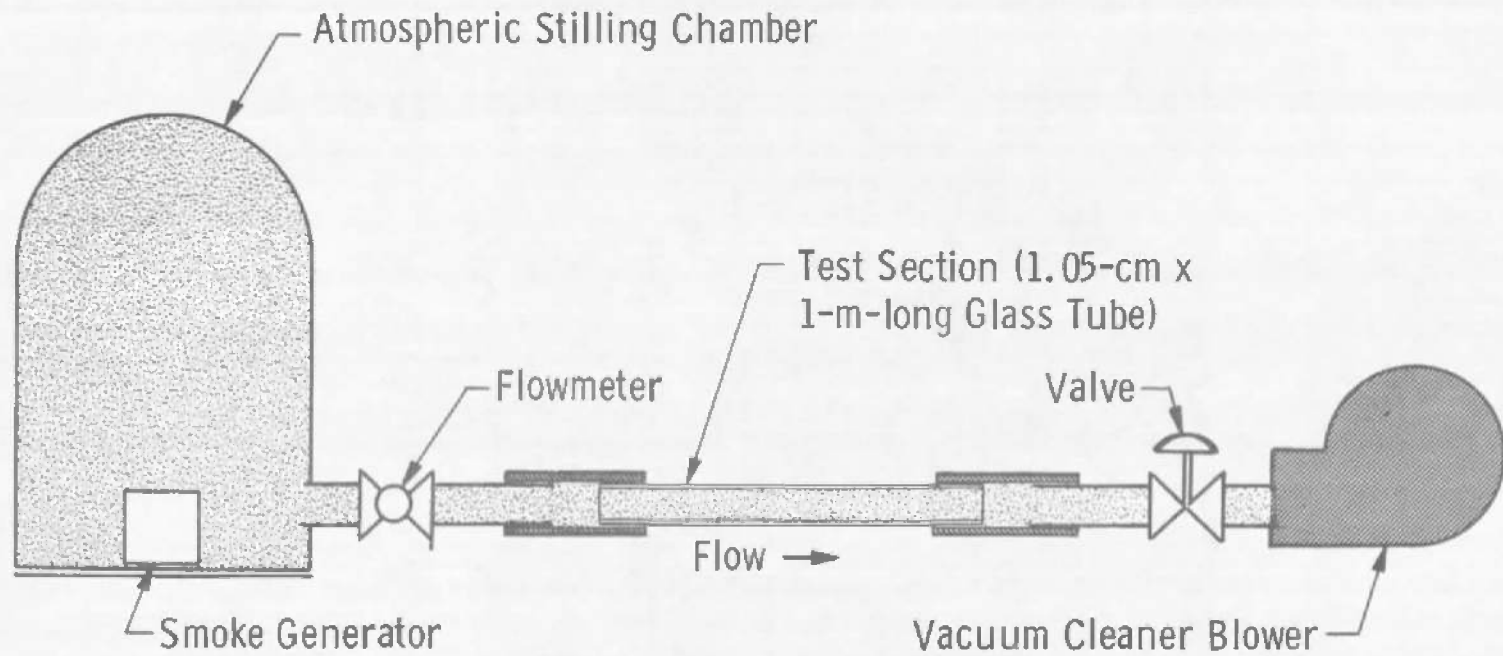

Fig. 13 Flow System for Velocity Measurements in Air

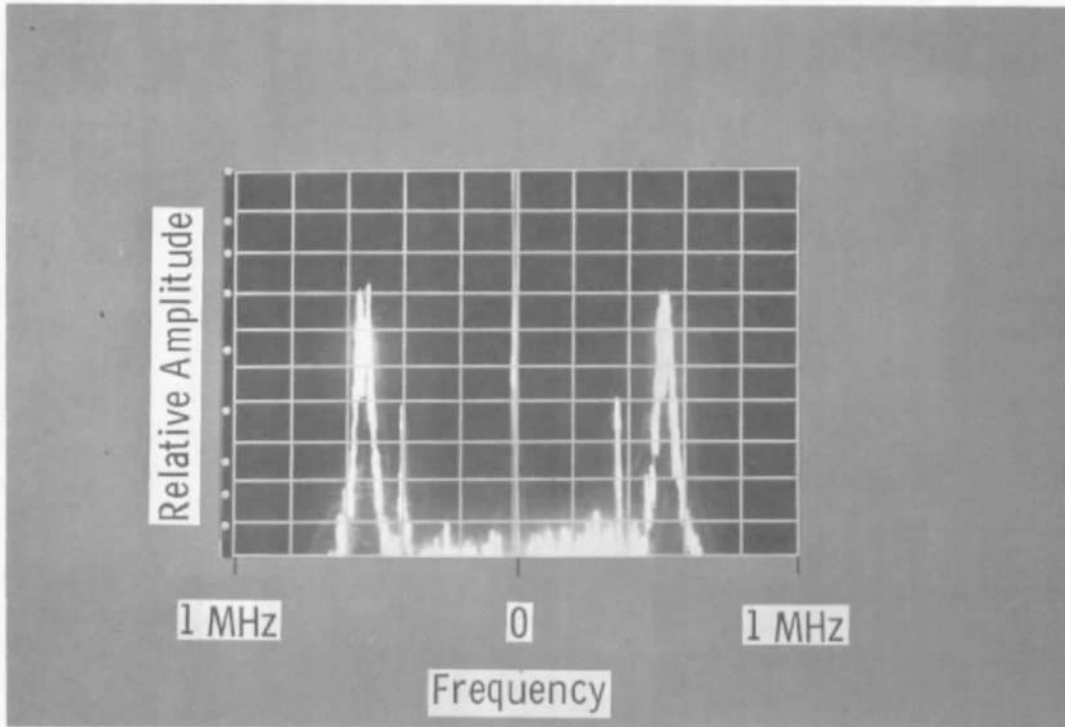

Fig. 14 Typical Spectrogram from the Air Velocity Measurements

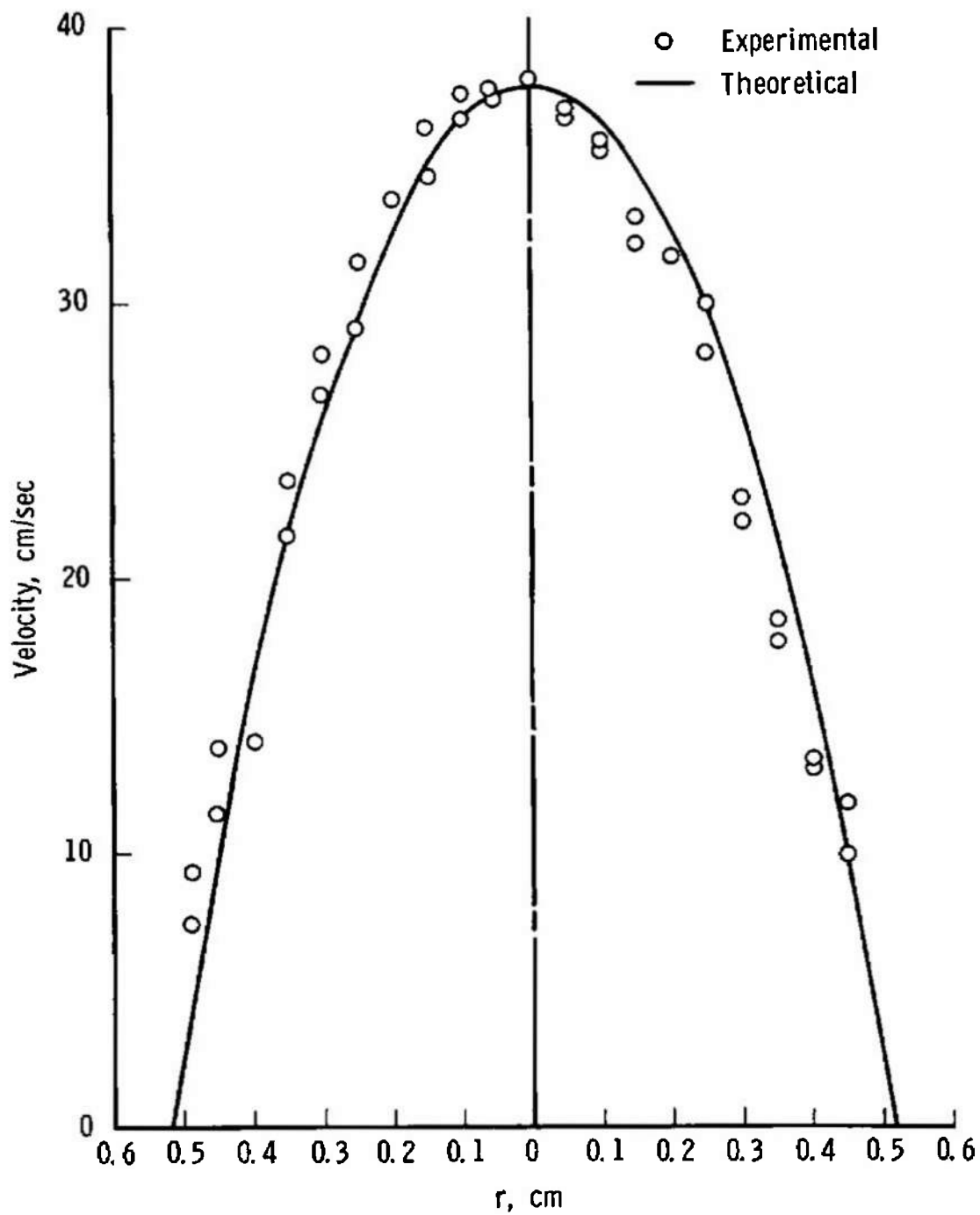

Fig. 15 Velocity Profile of Air in a Circular Pipe

DOCUMENT CONTROL DATA - R & D

(Security classification of title, body of abstract and indexing annotation must be entered when the overall report is classified)

1. ORIGINATING ACTIVITY (Corporate author) Arnold Engineering Development Center ARO, Inc., Operating Contractor Arnold Air Force Station, Tennessee		2a. REPORT SECURITY CLASSIFICATION UNCLASSIFIED	
		2b. GROUP N/A	
3. REPORT TITLE DEVELOPMENT OF A LASER VELOCIMETER SYSTEM			
4. DESCRIPTIVE NOTES (Type of report and inclusive dates) July 1966 to June 1967			
5. AUTHOR(S) (First name, middle initial, last name) J. I. Shipp, R. H. Hines, and W. A. Dunnill, ARO, Inc.			
6. REPORT DATE October 1967	7a. TOTAL NO. OF PAGES 34	7b. NO. OF REFS 4	
6a. CONTRACT OR GRANT NO. AF 40(600)-1200	9a. ORIGINATOR'S REPORT NUMBER(S) AEDC-TR-67-175		
b. PROJECT NO.	9b. OTHER REPORT NO(S) (Any other numbers that may be assigned this report) N/A		
c. Program Element 6540223F his document has been approved for public release d. ad sale; its distribution is unlimited.			
10. DISTRIBUTION STATEMENT This document is subject to special export controls and each transmittal to foreign governments or foreign nationals may be made only with prior approval of AEDC (AETS), Arnold Air Force Station, Tennessee.			
11. SUPPLEMENTARY NOTES Available in DDC		12. SPONSORING MILITARY ACTIVITY Arnold Engineering Development Center Air Force Systems Command Arnold Air Force Station, Tennessee	
13. ABSTRACT <p>The development of a laser velocimeter for point velocity measurements in liquid and gas flows is discussed. The principle of operation of the velocimeter is based on the Doppler effect, and the velocity measurements are accomplished by an optical homodyning technique. Velocity profiles are presented for laminar flow of water and air in circular flow channels. It was found that a correction factor was required when measuring velocities of fluids having indices of refraction different from air. The velocimeter is shown to be capable of velocity measurements of a vibrating surface.</p> <p style="text-align: center;">This document has been approved for public release and sale; its distribution is unlimited.</p> <p>This document is subject to special export controls and each transmittal to foreign governments or foreign nationals may be made only with prior approval of Arnold Engineering Development Center (AETS), Arnold Air Force Station, Tennessee. <i>file AF letter, 12 Dec 69, signed William O. Cole AETS</i></p>			

14

KEY WORDS

LINK A

LINK B

LINK C

ROLE

WT

ROLE

WT

ROLE

WT

1. laser velocimeters

gas flow measurement

V/STOL aircraft

shock tubes

jet plumes

2. velocimeters

3. Liquids... Velocity

4. gases ... "

77-5