

UNCLASSIFIED

AD NUMBER

AD821586

LIMITATION CHANGES

TO:

Approved for public release; distribution is unlimited.

FROM:

Distribution authorized to U.S. Gov't. agencies and their contractors;
Administrative/Operational Use; OCT 1967. Other requests shall be referred to Arnold Engineering Development Center, Arnold AFB, TN.

AUTHORITY

AEDC ltr 12 Dec 1969

THIS PAGE IS UNCLASSIFIED



**RANGE EXTENSION AND COMPONENT RESOLUTION
OF THE LASER VELOCIMETER**

**W. A. Dunnill, J. I. Shipp, and R. H. Hines
ARO, Inc.**

October 1967

This document is subject to special export controls and each transmittal to foreign governments or foreign nationals may be made only with prior approval of Arnold Engineering Development Center (AEDC), Arnold Air Force Station, Tennessee.

**ARNOLD ENGINEERING DEVELOPMENT CENTER
AIR FORCE SYSTEMS COMMAND
ARNOLD AIR FORCE STATION, TENNESSEE**

NOTICES

When U. S. Government drawings specifications, or other data are used for any purpose other than a definitely related Government procurement operation, the Government thereby incurs no responsibility nor any obligation whatsoever, and the fact that the Government may have formulated, furnished, or in any way supplied the said drawings, specifications, or other data, is not to be regarded by implication or otherwise, or in any manner licensing the holder or any other person or corporation, or conveying any rights or permission to manufacture, use, or sell any patented invention that may in any way be related thereto.

Qualified users may obtain copies of this report from the Defense Documentation Center.

References to named commercial products in this report are not to be considered in any sense as an endorsement of the product by the United States Air Force or the Government.

RANGE EXTENSION AND COMPONENT RESOLUTION
OF THE LASER VELOCIMETER

W. A. Dunnill, J. I. Shipp, and R. H. Hines
ARO, Inc.

This document is subject to special export controls and each transmittal to foreign governments or foreign nationals may be made only with prior approval of Arnold Engineering Development Center (AETS), Arnold Air Force Station, Tennessee.

FOREWORD

The work reported herein was done at the request of the Arnold Engineering Development Center (AEDC), Air Force Systems Command (AFSC), under Program Element 6540223F.

The results of research presented were obtained by ARO, Inc. (a subsidiary of Sverdrup & Parcel and Associates, Inc.), contract operator of the AEDC, AFSC, Arnold Air Force Station, Tennessee, under Contract AF40(600)-1200. The research was conducted from January to July, 1967, under ARO Project No. BB5706. The manuscript was submitted for publication on August 22, 1967.

The authors wish to acknowledge the invaluable assistance of R. G. Ray of the Experimental Research Group in the experimental phase of the work.

Information in this report is embargoed under the Department of State International Traffic in Arms Regulations. This report may be released to foreign governments by departments or agencies of the U. S. Government subject to approval of the Arnold Engineering Development Center (AEDC), or higher authority within the Department of the Air Force. Private individuals or firms require a Department of State export license.

This technical report has been reviewed and is approved.

Marshall K. Kingery
Research Division
Directorate of Plans and
Technology

Edward R. Feicht
Colonel, USAF
Director of Plans and
Technology

ABSTRACT

A method of increasing the upper limit of the velocity range of the laser velocimeter is discussed. The velocity increase is accomplished by arranging the optics so that the angle between the scattered and incident beam is minimized. For flow fields with two or three nonzero components, an expression is derived relating the magnitudes of each component to the measured frequency.

This document is subject to special export controls and each transmittal to foreign governments or foreign nationals may be made only with prior approval of Arnold Engineering Development Center (AETS), Arnold Air Force Station, Tennessee.

CONTENTS

	<u>Page</u>
ABSTRACT.	iii
NOMENCLATURE.	v
I. INTRODUCTION	1
II. THEORY	
2.1 Multicomponent Velocity Analysis	2
2.2 High Velocity Geometrical Analysis	4
III. EXPERIMENTATION	7
IV. CONCLUSIONS	9

ILLUSTRATIONS

Figure

1. Schematic Diagram of a Typical Laser Velocimeter System.	1
2. Off-Axis Optical Geometry.	3
3. Two-Dimensional Flow about a Model	4
4. Geometric Representation of Original Laser Velocimeter	6
5. Geometric Representation of Minimum Angle Difference (MAD) Laser Velocimeter	6
6. Schematic Diagram of the Minimum Angle Difference (MAD) Laser Velocimeter	7
7. Frequency versus Angular Dependence	8
8. Nomogram Relating Velocity to the Laser Velocimeter Parameters.	11

NOMENCLATURE

A	Cosine difference ratio
f_D	Doppler frequency, Hz
\hat{i}	Unit vector in the x-direction

\hat{j}	Unit vector in the y-direction
K_0	Magnitude of \bar{K}_0
\bar{K}_0	Wave vector of the incident laser radiation
K_s	Magnitude of \bar{K}_s
\bar{K}_s	Wave vector of the scattered laser radiation
K_{sx}	x-component of \bar{K}_s
K_{sy}	y-component of \bar{K}_s
K_{sz}	z-component of \bar{K}_s
\hat{k}	Unit vector in the z-direction
n	Index of refraction
V	Magnitude of \bar{V}
\bar{V}	Velocity vector
α	Angle between the incident laser radiation and the velocity
β	Angle between the scattered laser radiation and the velocity
γ	Angle between the z-axis (Fig. 2) and the projection of K_s in the X-Z plane
θ	Angle between the incident and scattered laser radiation
λ_0	Wavelength of emitted laser radiation
ψ	Angle between the incident laser radiation and the velocity
ω_D	Doppler frequency, radians/sec

SECTION I INTRODUCTION

The first laser velocimeter (LV) developed at the Arnold Engineering Development Center (AEDC) was used to measure point velocities of water and gas flows in a cylindrical tube.¹ A schematic diagram of this system is shown in Fig. 1. With this arrangement the velocity, V , of a fluid with an index of refraction, n , is related to the doppler frequency, f_D , and the geometry of the system by:

$$V = \frac{\lambda_0 f_D}{2n} \left[\sin \left(\frac{\theta}{2} \right) \sin \left(\psi + \frac{\theta}{2} \right) \right]^{-1} \quad (1)$$

where λ_0 is the wavelength of the emitted radiation. From Eq. (1) it can be seen that for an electronic readout system with a limited frequency response the upper limit of the velocity is determined by the system geometry (the smaller the geometrical term in the brackets, the higher the velocity for a given f_D). With the optical arrangement as shown in Fig. 1, it was found that θ , the angle between the incident and scattered light, could be reduced to approximately 8 deg. The limitation of the angle was dictated by the physical dimensions of the optical equipment.

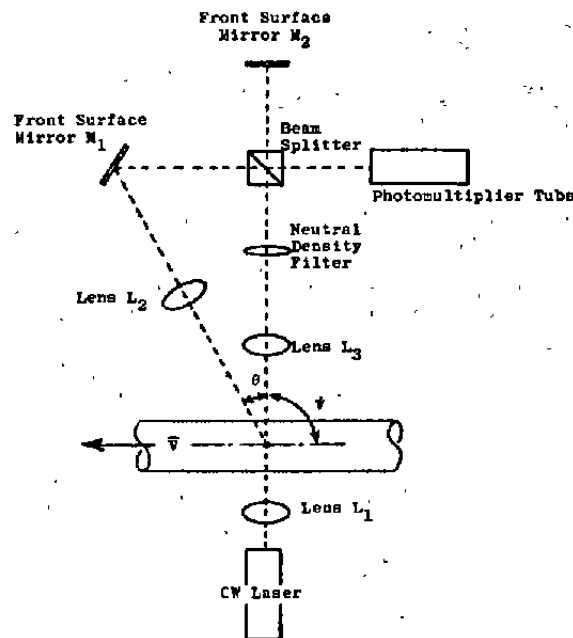

Fig. 1 Schematic Diagram of a Typical Laser Velocimeter System

¹J. I. Shipp, R. H. Hines, and W. A. Dunnill. "Development of a Laser Velocimeter System." AEDC-TR-67-175, October 1967.

In this report, a system is described in which the angularly dependent terms can be substantially reduced. It is shown theoretically that at least two orders of magnitude increase in velocity may be measured without altering the frequency response of the electronics. Data are presented for an order of magnitude increase in velocity measuring capability over the original system. In addition, an optical system for obtaining velocity profiles about an irregular model is described. For this application there may be two or three nonzero velocity components. The measured doppler frequency is shown to be proportional to an expression which is a function of all the velocity components. Equations are derived which yield the relative magnitudes of the velocity components.

SECTION II THEORY

2.1 MULTICOMPONENT VELOCITY ANALYSIS

In this section an expression is derived relating the doppler frequency to the components of velocity in a flow field. From the results it is seen that it is feasible to obtain the three components of velocity using the LV technique. In Fig. 2 the case is depicted where the velocity \vec{V} does not lie in the optics plane defined by \vec{K}_O and \vec{K}_S . Thus:

$$\begin{aligned}\vec{V} &= \hat{i} V_x + \hat{j} V_y + \hat{k} V_z \\ \vec{K}_O &= \hat{j} K_o \\ \vec{K}_S &= \hat{i} K_{sx} + \hat{j} K_{sy} + \hat{k} K_{sz}\end{aligned}\quad (2)$$

where

$$K_{sx} = K_s \sin \theta \sin \gamma$$

$$K_{sy} = K_s \cos \theta$$

$$K_{sz} = K_s \sin \theta \cos \gamma$$

The doppler frequency ω_D is related to the scattered wave vector, \vec{K}_S , the primary wave vector, \vec{K}_O , and the velocity, \vec{V} , of the moving source by:

$$\omega_D = (\vec{K}_S - \vec{K}_O) \cdot \vec{V} \quad (3)$$

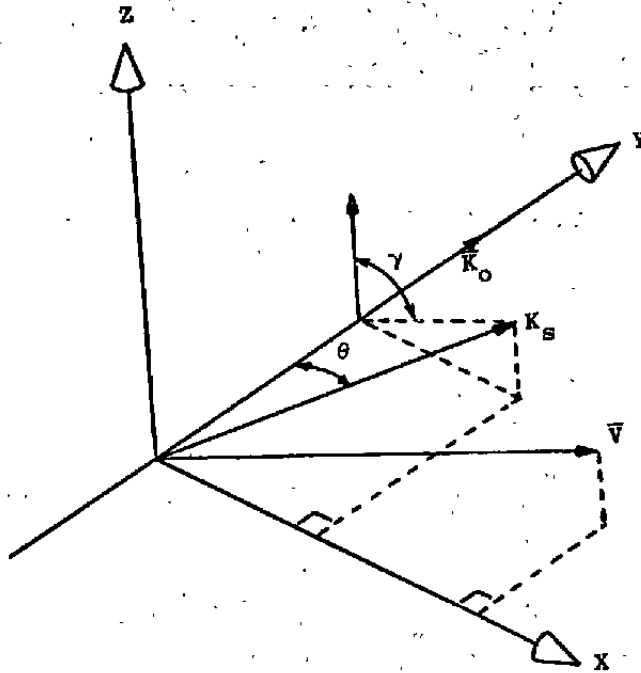

Fig. 2 Off-Axis Optical Geometry

Therefore

$$\omega_D = K_{sx} V_x + K_{sy} V_y + K_{sz} V_z - K_o V_y \quad (4)$$

where

$$K_o \approx K_s \equiv K$$

Combining Eqs. (2) and (4) yields:

$$\omega_D = K \left[V_x \sin \theta \sin \gamma + V_z \sin \theta \cos \gamma + V_y (\cos \theta - 1) \right] \quad (5)$$

For the case of small θ , Eq. (5) reduces to:

$$\omega_D = K\theta \left(V_x \sin \gamma + V_z \cos \gamma - V_y \frac{\theta}{2} \right) \quad (6)$$

The angles θ and γ are set, K is known, and ω_D is measured. Equation (6) contains three unknowns, V_x , V_y , and V_z . By introducing two more K_s measuring systems from the same point in the flow, three equations having three unknowns will be obtained which may readily be solved. Thus V_x , V_y , and V_z can be uniquely determined.

For the case where one velocity component is small compared to the other two, Eq. (6) can be simplified even further. As an example consider the flow about the model shown in Fig. 3. For this model it may be assumed that V_x and $V_z \gg V_y$.

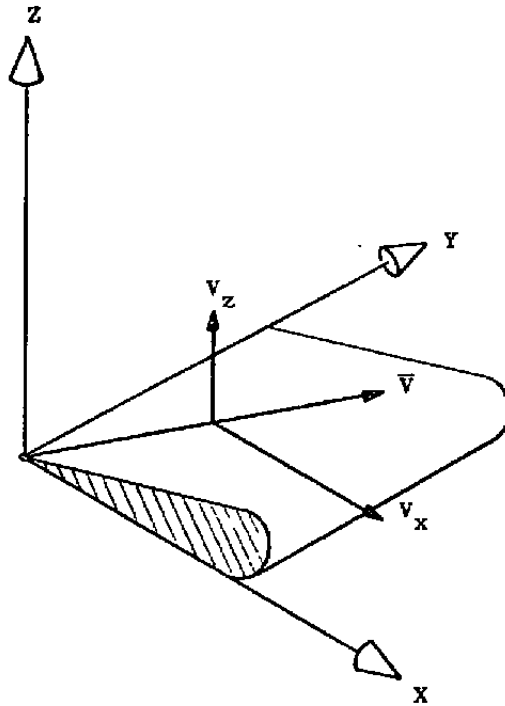

Fig. 3 Two-Dimensional Flow about a Model

Since θ is small and γ is unrestricted, the last term in the bracket (Eq. (6)) may be neglected. With additional algebraic manipulation the following expression results:

$$\omega_D = K\theta V_x \left(\sin \gamma + \frac{V_z}{V_x} \cos \gamma \right) \quad (7)$$

Therefore, to calculate V_x and V_z , only two systems would be required.

2.2 HIGH VELOCITY GEOMETRICAL ANALYSIS

Since the geometrical conditions define the upper limit of the LV for a given readout frequency response, optimization of the geometrical arrangement is desirable. In this section an optimization technique called the Minimum Angle Difference (MAD) system is theoretically evaluated.

If Eq. (3) is written in a form where the incident wavelength λ_0 of the laser beam is considered, it is found that the velocity may be described as follows:

$$V = \frac{\lambda_0 f_D}{n} (\cos \beta - \cos \alpha)^{-1} \quad (8)$$

where

$$K = \frac{2\pi n}{\lambda_0}$$

$$\omega_D = 2 f_D$$

n is the index of refraction, and β and α are defined in Figs. 4 and 5 for two different geometries. In Fig. 4 it is seen that the vector $\bar{K}_S - \bar{K}_O$ is almost parallel to \bar{V} . Consequently, the cosine of the angle between $\bar{K}_S - \bar{K}_O$ and \bar{V} is approximately unity. For practical applications, the frequency response of the electronic system is limited to some frequency f_{D1} , thereby setting the upper limit on the maximum measurable velocity. On the other hand, in the geometry shown in Fig. 5, where the difference between α and β is minimized, $\bar{K}_S - \bar{K}_O$ is almost perpendicular to \bar{V} . Thus, for the same limited frequency response, f_{D1} , the reduction in the cosine of the angle between $\bar{K}_S - \bar{K}_O$ and \bar{V} allows measurements of a higher velocity to be made. If we allow α_1 and β_1 to represent the angles shown in Fig. 4 and α_2 and β_2 to represent the angles shown in Fig. 5, the possible velocity increase is determined by the ratio of the differences of the cosines of the angle, A , i. e.,

$$A = \frac{\cos \beta_1 - \cos \alpha_1}{\cos \beta_2 - \cos \alpha_2} \quad (9)$$

For a practical example, consider the geometry shown in Fig. 4, where $\alpha_1 = 90$ deg and $\beta_1 = 98$ deg; thus $\cos \beta_1 - \cos \alpha_1 = 0.174$. For the geometry shown in Fig. 5, practical values for the angles could be $\alpha_2 = 15$ deg and $\beta_2 = 14$ deg; thus $\cos \beta_2 - \cos \alpha_2 = 0.004$. The ratio A is found to be:

$$A = \frac{0.174}{0.004} = 43.5$$

Therefore, for a given frequency response, use of the MAD geometry shown in Fig. 5 permits velocity measurements more than 40 times greater than those capable of being measured using the geometry shown in Fig. 4. For systems in which α_2 and β_2 differ by only a fraction of a degree, values of A on the order of 100 could be obtained.

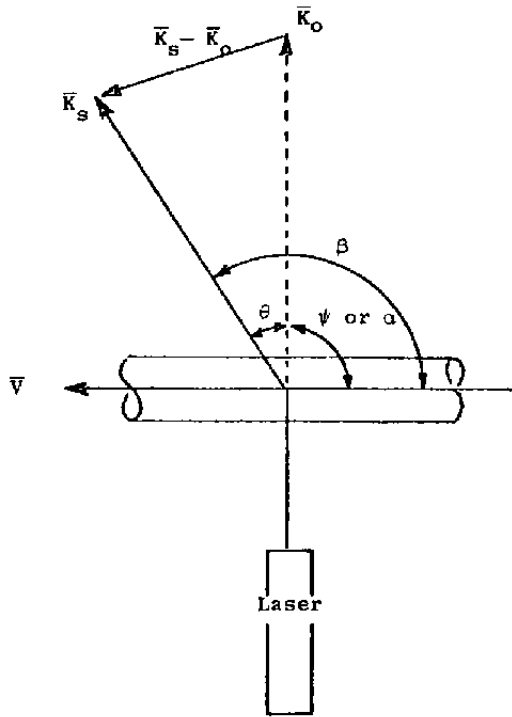

Fig. 4 Geometric Representation of Original Laser Velocimeter

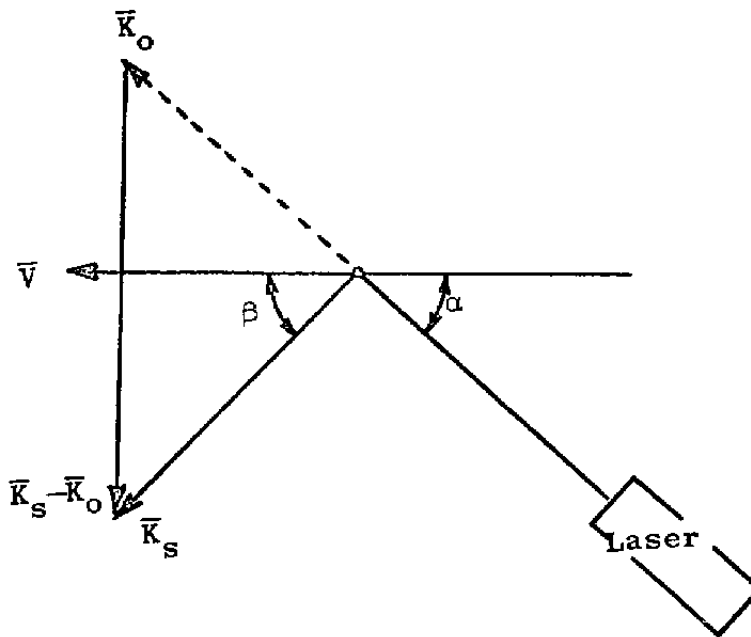

Fig. 5 Geometric Representation of Minimum Angle Difference (MAD) Laser Velocimeter

SECTION III EXPERIMENTATION

A schematic diagram of the minimum angle difference laser velocimeter (MAD-LV) is shown in Fig. 6. Light emitted from the laser is split by beam splitter BS_1 . The upper branch is focused to a point on the moving target by lens L_1 . From this point a small portion of the doppler shifted beam is scattered through an angle β . This scattered light is focused through the beam splitter BS_2 onto the photocathode surface by lens L_2 . The unscattered portion of the laser beam is focused by lens L_3 , is reflected at the front surface mirror, M_1 , and is rotated by beam splitter BS_2 so that it becomes incident on the photocathode surface. The two beams are optically homodyned at the photocathode surface to obtain the doppler frequency that is proportional to the velocity at the scattering point.

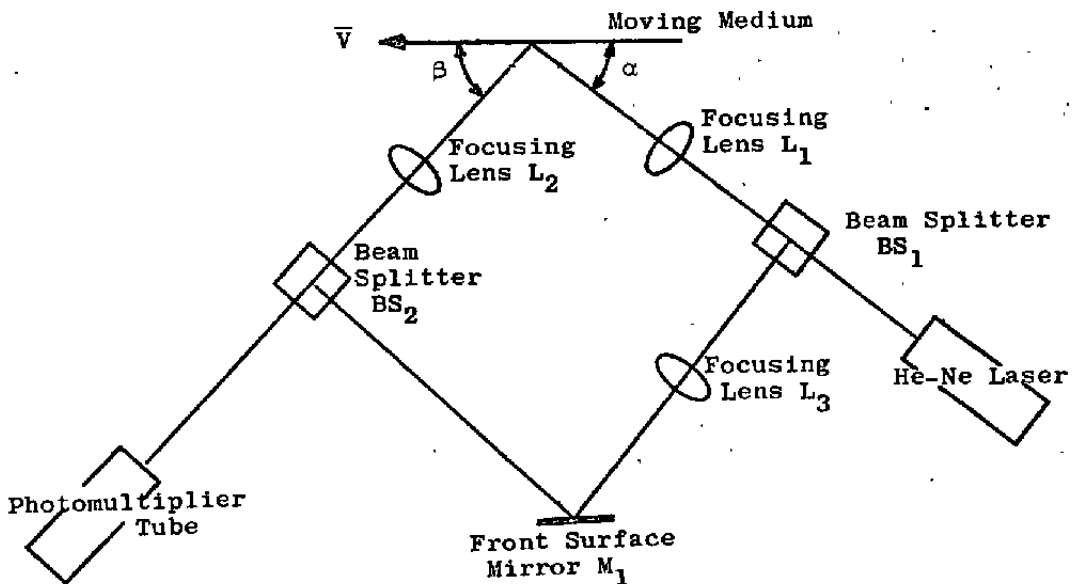

Fig. 6 Schematic Diagram of the Minimum Angle Difference (MAD) Laser Velocimeter

The moving medium in Fig. 6 consisted of a solid aluminum disk mounted on the shaft of a variable-speed electric motor. The linear velocity to be measured could be changed by either varying the motor speed or by varying the point along the disk radius at which the measurements were made. A stroboscope accurate to 1 percent was used to measure the rotation rate of the disk to provide a check for the velocities obtained with the MAD-LV.

The linear velocity at the measured radius of the disk, \bar{V} , was held at 240 cm/sec by monitoring its rotation rate with the stroboscope and adjusting the power to the motor. The angle α was set at 32.2 deg, and the angle β was varied from 47.6 to 34 deg. In Fig. 7 the solid line represents a plot of the frequency versus the difference of the cosines of the angles for a velocity of 240 cm/sec. The data points obtained by varying β and measuring f_D are seen to fall along the calculated line to within the accuracy involved in measuring the angles. At the maximum angular spread of 15.4 deg, f_D was found to be 635 kHz, whereas at the minimum angular spread of 1.8 deg, f_D was found to be 65 kHz.

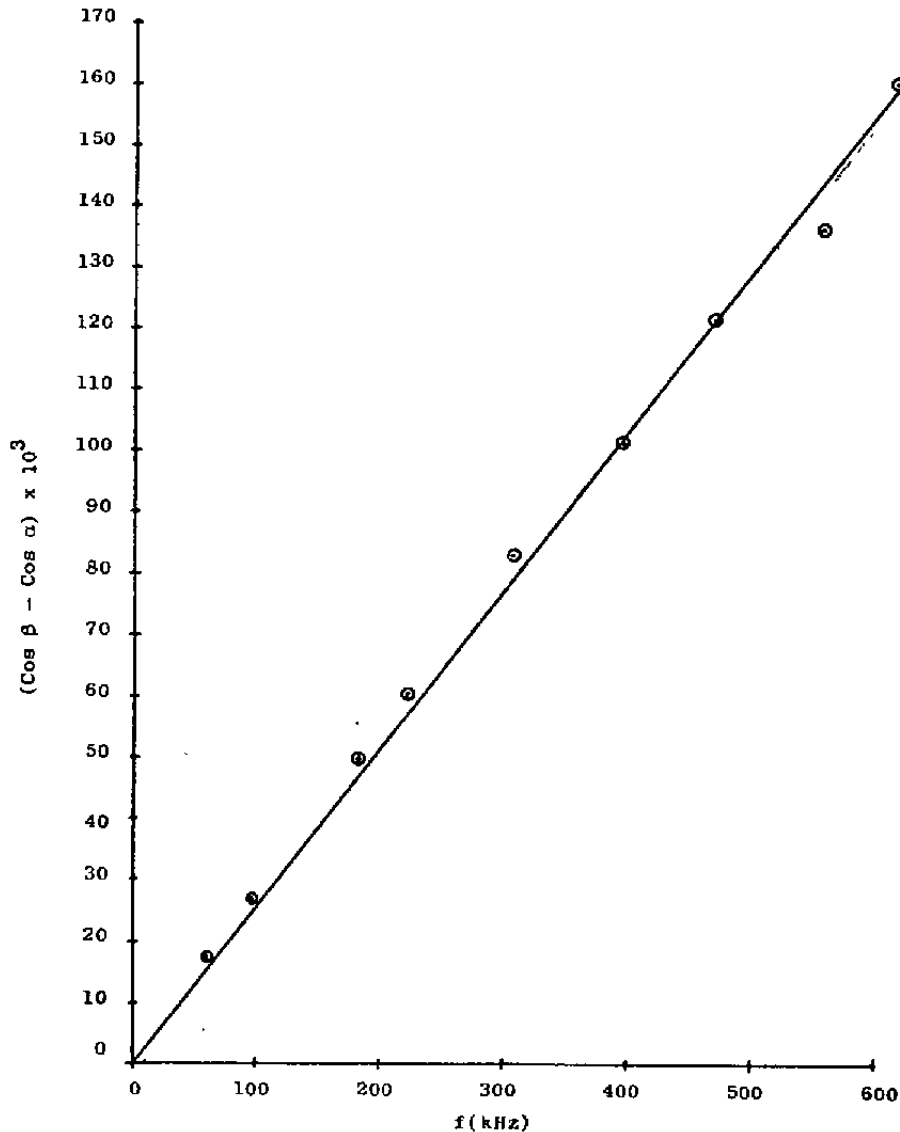

Fig. 7 Frequency versus Angular Dependence

As β approached the spectral angle of reflection, the intensity of the scattered light increased, thereby causing an increase in the noise-to-signal ratio. For angular differences below 1.8 deg, the noise increased to a level sufficient to mask out the signal. However, the decrease of the frequency by an order of magnitude for constant velocity verifies the theoretically predicted results using the MAD geometry.

For fluid flow measurements the noise-to-signal ratio should not increase as $(\beta - \alpha)$ approaches zero. Therefore, the accurate upper measurable velocity is limited only by the minimum value of $(\beta - \alpha)$ which can be experimentally determined.

To compare the standard LV system and the MAD-LV system, assume that the frequency response is 3 MHz, the limiting value of the original experiment. The minimum value for the angle θ of Fig. 1 was 8 deg because of the physical size of the optical equipment. Thus the upper velocity limit, obtained from Eq. (1), was found to be 1350 cm/sec. With the use of the MAD-LV system shown in Fig. 2, angle differences of 0.5 deg may be readily obtained. Thus for a set of values of $\beta = 14.0$ deg and $\alpha = 14.5$ deg, a 3-MHz signal would correspond to a velocity of 88,600 cm/sec - an increase of over a factor of 60. A nomogram relating the angles α and β , the velocity V , and the frequency f_D was constructed and is shown in Fig. 8. From Fig. 8, it can be seen that velocities in the 10^5 cm/sec range should be measurable with a system having a frequency response of 3 MHz.

SECTION IV CONCLUSIONS

The linear velocity at a fixed radius on a rotating disk was measured using the Minimum Angle Difference (MAD) Laser Velocimeter. The data obtained for the velocity measurements were experimentally verified by independent means. For a given velocity, the doppler frequency was lowered by one order of magnitude, and it was shown, theoretically, that at least two orders of magnitude increase in fluid flow velocity can be measured.

Expressions were derived relating the doppler frequency to the velocity components for the case where the vector velocity is unknown. To obtain three velocity components in a given coordinate system, three LV systems must be used to define the three components of velocity uniquely. The expressions that were derived may also be used to obtain the flow velocity about an irregular surface such as an aerodynamic model in a wind tunnel.

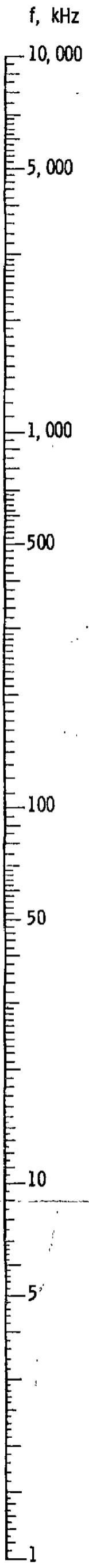

Line up the α and β angle scales and read off the M scale.
 Transfer this value to the N scale, line up the N and f scales, and read velocity on the V scale.

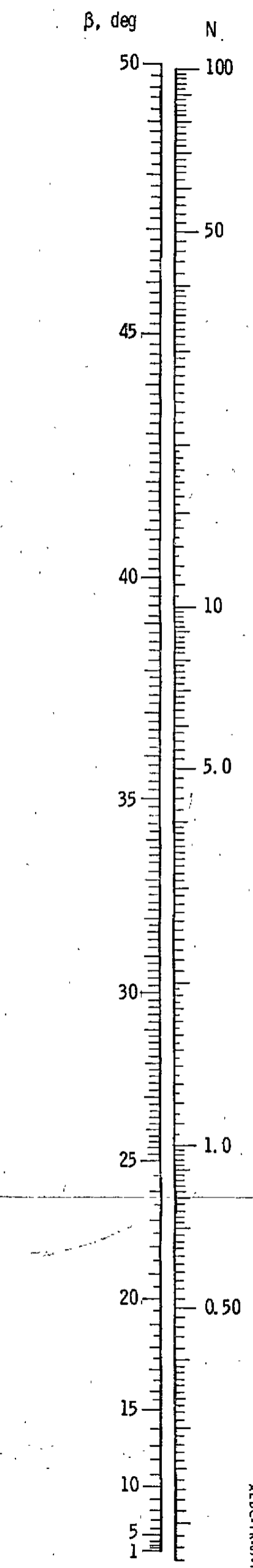
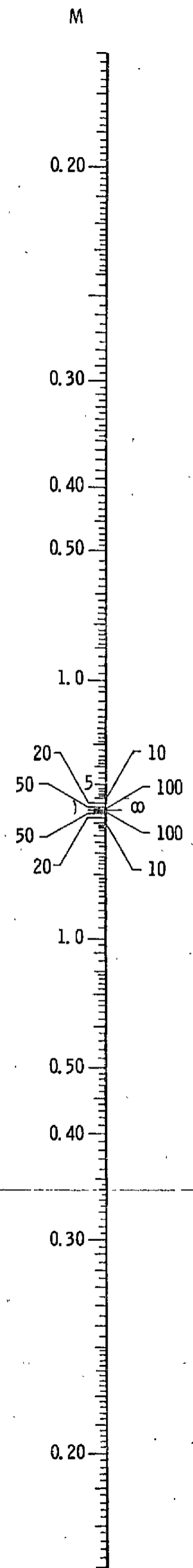
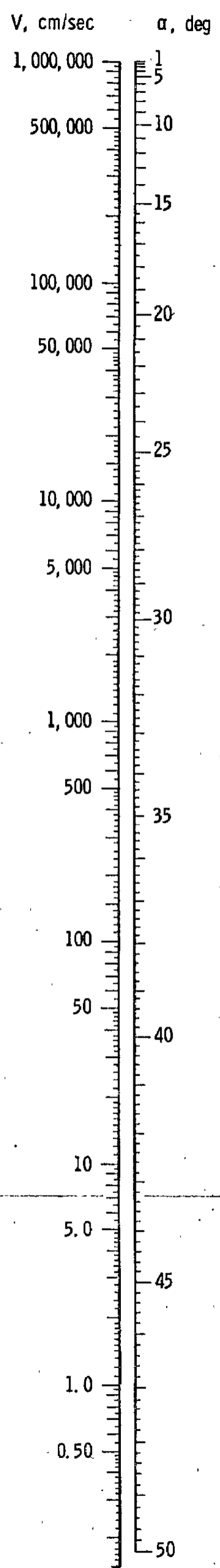

Fig. 8 Nomogram Relating Velocity to the Laser Velocimeter Parameters

DOCUMENT CONTROL DATA - R & D

(Security classification of title, body of abstract and indexing annotation must be entered when the overall report is classified)

1. ORIGINATING ACTIVITY (Corporate author) Arnold Engineering Development Center ARO, Inc., Operating Contractor Arnold Air Force Station, Tennessee		2a. REPORT SECURITY CLASSIFICATION UNCLASSIFIED	
		2b. GROUP N/A	
3. REPORT TITLE RANGE EXTENSION AND COMPONENT RESOLUTION OF THE LASER VELOCIMETER			
4. DESCRIPTIVE NOTES (Type of report and inclusive dates) Interim Report - January to July 1967			
5. AUTHOR(S) (First name, middle initial, last name) W. A. Dunnill, J. I. Shipp, and R. H. Hines, ARO, Inc.			
6. REPORT DATE October 1967	7a. TOTAL NO. OF PAGES 17	7b. NO. OF REFS 1	
8a. CONTRACT OR GRANT NO. AF 40(600)-1200	9a. ORIGINATOR'S REPORT NUMBER(S) AEDC-TR-67-195		
b. Program Element 6540223F	9b. OTHER REPORT NO(S) (Any other numbers that may be assigned this report) N/A		
c.			
d.			
10. DISTRIBUTION STATEMENT Subject to special export controls; transmittal to foreign governments or foreign nationals requires approval of Arnold Engineering Development Center (AETS), Arnold Air Force Station, Tennessee.			
11. SUPPLEMENTARY NOTES Available in DDC		12. SPONSORING MILITARY ACTIVITY Arnold Engineering Development Center, Air Force Systems Command, Arnold Air Force Station, Tennessee	
13. ABSTRACT A method of increasing the upper limit of the velocity range of the laser velocimeter is discussed. The velocity increase is accomplished by arranging the optics so that the angle between the scattered and incident beam is minimized. For flow fields with two or three nonzero components, an expression is derived relating the magnitudes of each component to the measured frequency. This document is subject to special export controls and each transmittal to foreign governments or foreign nationals may be made only with prior approval of Arnold Engineering Development Center (AETS), Arnold Air Force Station, Tennessee			

KEY WORDS	LINK A		LINK B		LINK C	
	ROLE	WT	ROLE	WT	ROLE	WT
lasers velocimeters resolution range performance						