

UNCLASSIFIED

AD NUMBER

AD821828

LIMITATION CHANGES

TO:

Approved for public release; distribution is unlimited.

FROM:

Distribution authorized to DoD only;
Administrative/Operational Use; OCT 1967. Other
requests shall be referred to Arnold
Engineering Development Center, Arnold AFB, TN.

AUTHORITY

USAEDC ltr, 12 Jul 1974

THIS PAGE IS UNCLASSIFIED

g1

**ALTITUDE DEVELOPMENTAL TESTING
OF THE J-2 ROCKET ENGINE
IN PROPULSION ENGINE TEST CELL (J-4)
(TEST J4-1801-05)**



This document has been approved for public release
and its distribution is unlimited. *Per A.F. Letter dt'd
12 July, 74 signed
William O. Cole.*

H. J. Counts, Jr.

ARO, Inc.

October 1967 PROPERTY OF U. S. AIR FORCE
AEDC LIBRARY
AF 40(600)1200

This document is subject to special export controls and each transmittal to foreign governments or foreign nationals may be made only with prior approval of NASA Marshall Space Flight Center (I-E-J), Huntsville, Alabama.

Each transmittal of this document outside the Department of Defense must have prior approval of NASA Marshall Space Flight Center (I-E-J), Huntsville, Alabama.

**LARGE ROCKET FACILITY
ARNOLD ENGINEERING DEVELOPMENT CENTER
AIR FORCE SYSTEMS COMMAND
ARNOLD AIR FORCE STATION, TENNESSEE**

PROPERTY OF U. S. AIR FORCE
AEDC LIBRARY
AF 40(600)1200

AEDC TECHNICAL LIBRARY



5 0720 00031 5962

NOTICES

When U. S. Government drawings specifications, or other data are used for any purpose other than a definitely related Government procurement operation, the Government thereby incurs no responsibility nor any obligation whatsoever, and the fact that the Government may have formulated, furnished, or in any way supplied the said drawings, specifications, or other data, is not to be regarded by implication or otherwise, or in any manner licensing the holder or any other person or corporation, or conveying any rights or permission to manufacture, use, or sell any patented invention that may in any way be related thereto.

Qualified users may obtain copies of this report from the Defense Documentation Center.

References to named commercial products in this report are not to be considered in any sense as an endorsement of the product by the United States Air Force or the Government.

ALTITUDE DEVELOPMENTAL TESTING
OF THE J-2 ROCKET ENGINE
IN PROPULSION ENGINE TEST CELL (J-4)
(TEST J4-1801-05)

H. J. Counts, Jr.
ARO, Inc.

This document is subject to special export controls and each transmittal to foreign governments or foreign nationals may be made only with prior approval of NASA Marshall Space Flight Center (I-E-J), Huntsville, Alabama.

Each transmittal of this document outside the Department of Defense must have prior approval of NASA Marshall Space Flight Center (I-E-J), Huntsville, Alabama.

This document has been approved for public release
its distribution is unlimited.

*Per Air Force letter dt'd
12 July, 1974 signed
William O. Cole.*

FOREWORD

The work reported herein was sponsored by the National Aeronautics and Space Administration (NASA), Marshall Space Flight Center (MSFC) under System 921E, Project 9194.

The results of the tests presented were obtained by ARO, Inc. (a subsidiary of Sverdrup & Parcel and Associates, Inc.), contract operator of the Arnold Engineering Development Center (AEDC), Air Force Systems Command (AFSC), Arnold Air Force Station, Tennessee, under contract AF40(600)-1200. Program direction was provided by NASA/MSFC; technical direction and engineering liaison were provided by North American Aviation, Inc., Rocketdyne Division, manufacturer of the J-2 rocket engine; and engineering liaison was provided by Douglas Aircraft Company, manufacturer of the S-IVB stage. The testing reported herein was conducted on August 15, 1967 in Propulsion Engine Test Cell (J-4) of the Large Rocket Facility (LRF) under ARO Project No. KA1801. The manuscript was submitted for publication on September 15, 1967.

Information in this report is embargoed under the Department of State International Traffic in Arms Regulations. This report may be released to foreign governments by departments or agencies of the U. S. Government subject to approval of NASA Marshall Space Flight Center (I-E-J), Huntsville, Alabama, or higher authority within the Department of the Air Force. Private individuals or firms require a Department of State export license.

This technical report has been reviewed and is approved.

Harold Nelson, Jr.
Captain, USAF
AF Representative, LRF
Directorate of Test

Leonard T. Glaser
Colonel, USAF
Director of Test

ABSTRACT

Twenty-one valve sequence operations of the Rocketdyne J-2 engine were conducted on August 15, 1967 in Propulsion Engine Test Cell (J-4) of the Large Rocket Facility, Arnold Engineering Development Center. The tests were accomplished during test period J4-1801-05 at local atmospheric pressure conditions to evaluate the effects of thermal conditioning on the main oxidizer valve operation. Fuel lead times of 1, 3, and 8 sec were simulated by varying the time between engine start and start tank discharge valve control solenoid energized. Engine components which were thermally conditioned included the (1) helium tank, (2) helium regulator, (3) main oxidizer valve closing control line, and (4) main oxidizer valve second stage actuator.

This document is subject to special export controls and each transmittal to foreign governments or foreign nationals may be made only with prior approval of NASA Marshall Space Flight Center (I-E-J), Huntsville, Alabama.

This document has been approved for public release
its distribution is unlimited.

*By AF Letter
dt 125 July 74
Signed William O. Cole.*

CONTENTS

	<u>Page</u>
ABSTRACT	iii
NOMENCLATURE	vi
I. INTRODUCTION	1
II. APPARATUS	1
III. PROCEDURE	4
IV. RESULTS AND DISCUSSION	4
V. SUMMARY OF RESULTS.	5
REFERENCES	6

APPENDIXES

I. ILLUSTRATIONS

Figure

1. J-4 Test Area Complex.	9
2. Test Cell J-4 Artist's Conception	10
3. Details of the J-2 Engine	11
4. Main Oxidizer Valve Installation	12
5. J-2 Engine Schematic	13
6. J-2 Engine Start Logic Schematic	14
7. Start and Shutdown Sequence	15
8. Thermal Conditioning System Schematic	16
9. Typical Main Oxidizer Valve Position Trace	17
10. Fuel Lead Time versus Valve Total Travel Time	18
11. Main Oxidizer Valve Second Stage Actuator Temperature versus Second Stage Ramp Time	19
12. Thermostatic Orifice Characteristics	20
13. Thermostatic Orifice Installation	21
14. Calculated Pneumatic Torque versus Fuel Lead Time	22

	<u>Page</u>
II. TABLES	
I. Major J-2 Engine (S/N J-2052) Components for Test J4-1801-05	23
II. Engine Component Replacements (Between Test J4-1801-04 and Test J4-1801-05).	24
III. Summary of Test Requirements and Results	25
IV. Main Oxidizer Valve Timing	26
III. INSTRUMENTATION FOR TEST J4-1801-05	27

NOMENCLATURE

- ASI Augmented spark igniter
- ES Engine start, designated as the time that the helium
control and ignition phase solenoids are energized
- GG Gas generator
- MOV Main oxidizer valve
- STDV Start tank discharge valve
- t_o Defined as the time at which the opening signal is applied
to the start tank discharge valve solenoid

SECTION I INTRODUCTION

Testing of the Rocketdyne J-2 rocket engine (S/N J-2052) with a Douglas Aircraft Company S-IVB battleship stage has been in progress since July 1966 at AEDC, in support of the J-2 engine application on the Saturn IB and Saturn V launch vehicles for the NASA Apollo Program. The twenty-one valve sequence operations reported herein were conducted during test period J4-1801-05 on August 15, 1967 in Propulsion Engine Test Cell (J-4) (Figs. 1 and 2, Appendix I), of the Large Rocket Facility (LRF) to evaluate the effects of thermal conditioning on the main oxidizer valve operating time. Fuel lead times of 1, 3, and 8 sec were simulated by varying the time between engine start and start tank discharge valve control solenoid energized. Engine components which were thermally conditioned included the (1) helium tank, (2) helium regulator, (3) main oxidizer valve closing control line, and (4) main oxidizer valve second stage actuator. All sequence operations were conducted at local atmospheric pressure conditions; propellants were not transferred to the test stage during this test period.

Data collected to accomplish the test objectives are presented herein. Copies of all data obtained during this test have been previously supplied to the sponsor, and copies are on file at AEDC. The results of the previous test period are reported in Ref. 1.

SECTION II APPARATUS

2.1 TEST ARTICLE

The test article was a J-2 rocket engine (Fig. 3) designed and developed by Rocketdyne Division of North American Aviation, Inc. The engine uses liquid oxygen and liquid hydrogen as propellants, and has a thrust rating of 225,000 lbf at an oxidizer to fuel mixture ratio of 5.5. An S-IVB battleship stage, designed and developed by Douglas Aircraft Company, is used to supply propellants to the engine for normal firings, but was not used for this test.

A list of the major engine components for this test period are presented in Table I (Appendix II). No engine modifications were made since the previous test; component replacements performed since the previous test period are presented in Table II.

Engine components pertinent to this test included: (1) main oxidizer valve, (2) helium tank, and (3) helium regulator. The main oxidizer valve (Fig. 4) is a butterfly-type valve, spring-loaded to the closed position, pneumatically operated to the open position, and pneumatically assisted to the closed position. The helium tank is a 1000-cu-in. sphere located inside the hydrogen start tank which provides helium for the engine pneumatic system. The helium regulator, which is a part of the engine pneumatic system, reduces the pneumatic supply pressure from the helium tank to the desired pressure for engine valve operation.

At engine start, helium flows from the helium regulator into the main oxidizer valve second stage actuator, which tends to close the valve. At mainstage control solenoid energized, helium is routed to both the first and second stage opening ports. The first stage actuator opens the valve to a 14-deg position; the second stage actuator opens the valve from 14 deg to full open by a combination of a constant opening pressure and venting of closing pressure through a thermally compensating orifice. A mechanical schematic of the J-2 engine is shown in Fig. 5.

2.2 TEST CELL

Propulsion Engine Test Cell (J-4), Fig. 2, is a vertically oriented test unit designed for static testing liquid-propellant rocket engines and propulsion systems at pressure altitudes of 100,000 ft. The basic cell construction provides a 1.5 million-lbf-thrust capacity. The cell consists of four major components: (1) test capsule, 48 ft in diameter and 82 ft in height, situated at grade level and containing the test article; (2) spray chamber, 100 ft in diameter and 250 ft in depth, located directly beneath the test capsule to provide exhaust gas cooling and dehumidification; (3) coolant water, steam, nitrogen (gaseous and liquid), hydrogen (gaseous and liquid), liquid oxygen and gaseous helium storage and delivery systems for operation of the cell and test article; and (4) control building, containing test article controls, test cell controls, and data acquisition equipment.

The battleship stage and the J-2 engine were oriented vertically downward on the centerline of the diffuser-steam ejector assembly. This assembly consisted of a diffuser duct (20 ft in diameter by 150 ft in length), a centerbody steam ejector within the diffuser duct, a diffuser insert (13.5 ft in diameter by 30 ft in length) at the inlet to the diffuser duct, and a gaseous nitrogen annular ejector above the diffuser insert.

2.3 INSTRUMENTATION

Instrumentation systems were provided to measure engine and facility parameters. The engine instrumentation was comprised of (1) flight instrumentation for the measurement of critical engine parameters and (2) facility instrumentation which was provided to verify the flight instrumentation and to measure additional engine parameters. The flight instrumentation was provided and calibrated by the engine manufacturer; facility instrumentation was initially calibrated and periodically recalibrated at AEDC. Appendix III contains a list of all engine instrumentation and the locations of selected instrumentation.

Pressure measurements were made using strain-gage-type pressure transducers. Temperature measurements were made using resistance temperature transducers and thermocouples. Primary engine valves were instrumented with linear potentiometers and limit switches.

The data acquisition systems were calibrated by (1) precision electrical shunt resistance substitution for the pressure transducers and resistance temperature transducer units, and (2) voltage substitution for the thermocouples.

The types of data acquisition and recording systems used during this test period were (1) a multiple-input digital data acquisition system (Microsadic[®]) scanning each parameter at 40 samples per second and recording on magnetic tape, (2) photographically recording galvanometer oscillographs, (3) direct-inking, null-balance potentiometer-type strip charts. Applicable systems were calibrated prior to the test. Television cameras were used to provide visual coverage during the test period.

2.4 CONTROLS

Control of the J-2 engine and test cell systems was provided from the test cell control room. A facility control logic network was provided to interconnect the engine control system, major stage systems, and the countdown sequencer. A schematic of the engine start control logic is presented in Fig. 6. The engine logic requires the completion of certain events before a successful start sequence can be conducted. Since an actual firing was not made, the events which were simulated included augmented spark igniter ignition detect, mainstage pressure switch actuated, and a fuel injector temperature of -150°F or colder. The sequence of engine events for a normal start and shutdown is presented in Fig. 7.

SECTION III PROCEDURE

Preoperational procedures were begun several hours prior to the test period. Pertinent consumable storage systems were replenished, as required, and engine inspection, leak checks, and drying procedures were conducted. An engine pneumatic sample was taken to ensure that specification requirements were met. Instrumentation calibrations were conducted. Thermal conditioning of the various engine components was accomplished as required, using the facility-supplied engine component conditioning system (Fig. 8). Engine components which required thermal conditioning were the (1) helium tank, (2) helium regulator, (3) main oxidizer valve closing control line, and (4) main oxidizer valve second stage actuator. The engine component conditioning system utilized a liquid hydrogen-helium heat exchanger to provide the chilled helium for component conditioning. The start tank was vented to atmospheric pressure prior to each sequence to prevent gas from flowing through the turbine system.

SECTION IV RESULTS AND DISCUSSION

Twenty-one valve sequence operations were conducted on August 15, 1967 during test period J4-1801-05 to determine the effect of thermal conditioning on main oxidizer valve operating characteristics. Testing was accomplished at local atmospheric pressure conditions with components chilled over a range which included predicted S-IVB boattail values. The data presented are those that were recorded on the digital data acquisition system, except as noted.

Test requirements requested thermal conditioning of the helium tank gas, helium regulator, and main oxidizer valve closing control line and second stage actuator. The start tank discharge valve was delayed to simulate fuel leads of 1, 3, and 8 sec. Table III presents the conditioning targets for the engine components and measured test conditions at t_0 . Table IV presents start and shutdown transient operating times of the main oxidizer valve trace. Figure 9 shows a typical main oxidizer valve trace.

Main oxidizer valve total travel time is plotted against fuel lead time in Fig. 10. It can be seen that sequences with a chilled second stage actuator lie in a band relatively close together. When propellants are in the engine, the main oxidizer valve will chill to a temperature within the chilled test range (-150°F to -250°F) (Table III). With a chilled actuator, the other components, regardless of their temperature, have little effect

on main oxidizer valve operation. It may also be concluded that with propellants on the engine, the helium regulator and main oxidizer valve closing control line and second stage actuator need not be conditioned.

Figures 10 and 11 show that there is also considerable difference between ambient and chilled actuator sequence operations. This is due to the characteristics of the thermostatically controlled orifice in the closing control pressure vent line (Figs. 12 and 13). Travel times would have been approximately equal for both ambient and chilled actuator operations, had the orifice operated as designed. However, the orifice overcompensated, opening more than necessary, thus allowing the gas to vent faster than the designed 8.34 scim. From data available, there was no way of determining the temperature at which the orifice started to compensate.

As shown in Figs. 10 and 11, both the valve total travel time and second stage ramp time tended to increase with increasing fuel lead.

Pneumatic torque for sequences A through U was calculated by the Rocketdyne supplied equation at the time the main oxidizer valve moved from the 14-deg plateau, using closing control line pressure (POVCC) and helium regulator outlet pressure (PHRO):

$$\text{Pneumatic Torque (in. lb)} = [9.00(\text{PHRO}) - 9.797(\text{POVCC})] \times 1.08$$

These torque values are plotted in Fig. 14. A higher pneumatic torque is required to actuate the valve as the actuator temperature is reduced from ambient (+70°F) to cold (-150°F). There was considerable scatter in the data as the actuator temperature was decreased from -150°F to -250°F.

SECTION V SUMMARY OF RESULTS

The results of the twenty-one sequence operations of the Rocketdyne J-2 Rocket Engine conducted on August 15, 1967 in Propulsion Engine Test Cell (J-4) are summarized as follows:

1. Component temperatures showed no significant influence on main oxidizer valve operation when second stage actuator temperature was in the range of -150°F to -250°F.
2. Longer start tank discharge valve delay (fuel lead) tended to slow the valve second stage ramp rate and total travel time in the absence of engine vibration and hydraulic torque.

3. Higher pneumatic torque was generally needed to move the valve from the 14-deg plateau as the second stage actuator temperature decreased in the absence of engine vibration and hydraulic torque.

REFERENCES

1. Dougherty, N. S. "Altitude Testing of the J-2 Rocket Engine in Propulsion Engine Test Cell (J-4) (Test J4-1801-04)." AEDC-TR-67- , 1967.
2. "J-2 Rocket Engine, Technical Manual Engine Data." R-3825, August 1965.

APPENDIXES

- I. ILLUSTRATIONS**
- II. TABLES**
- III. INSTRUMENTATION FOR TEST J4-1801-05**

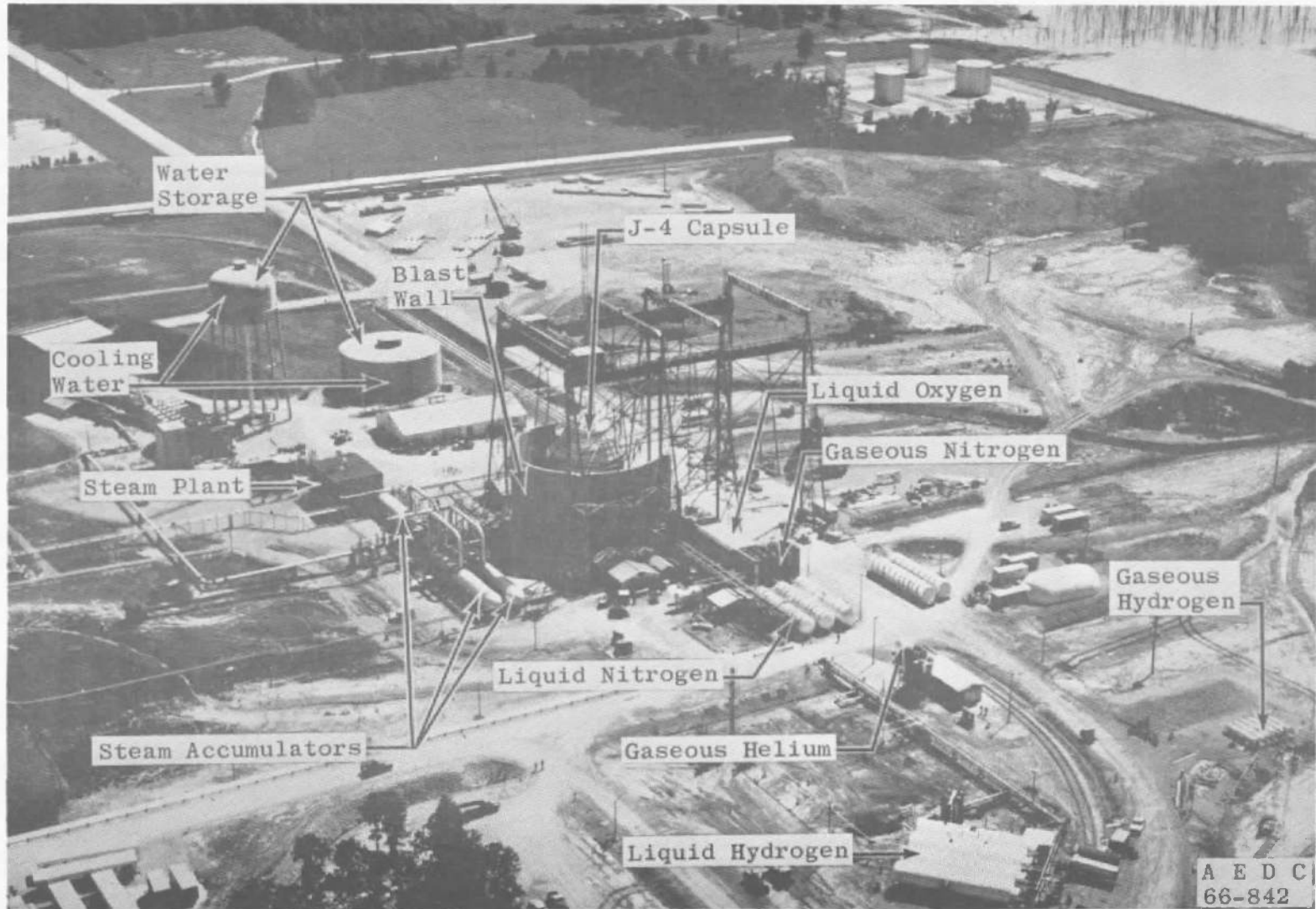

Fig. 1 J-4 Test Area Complex

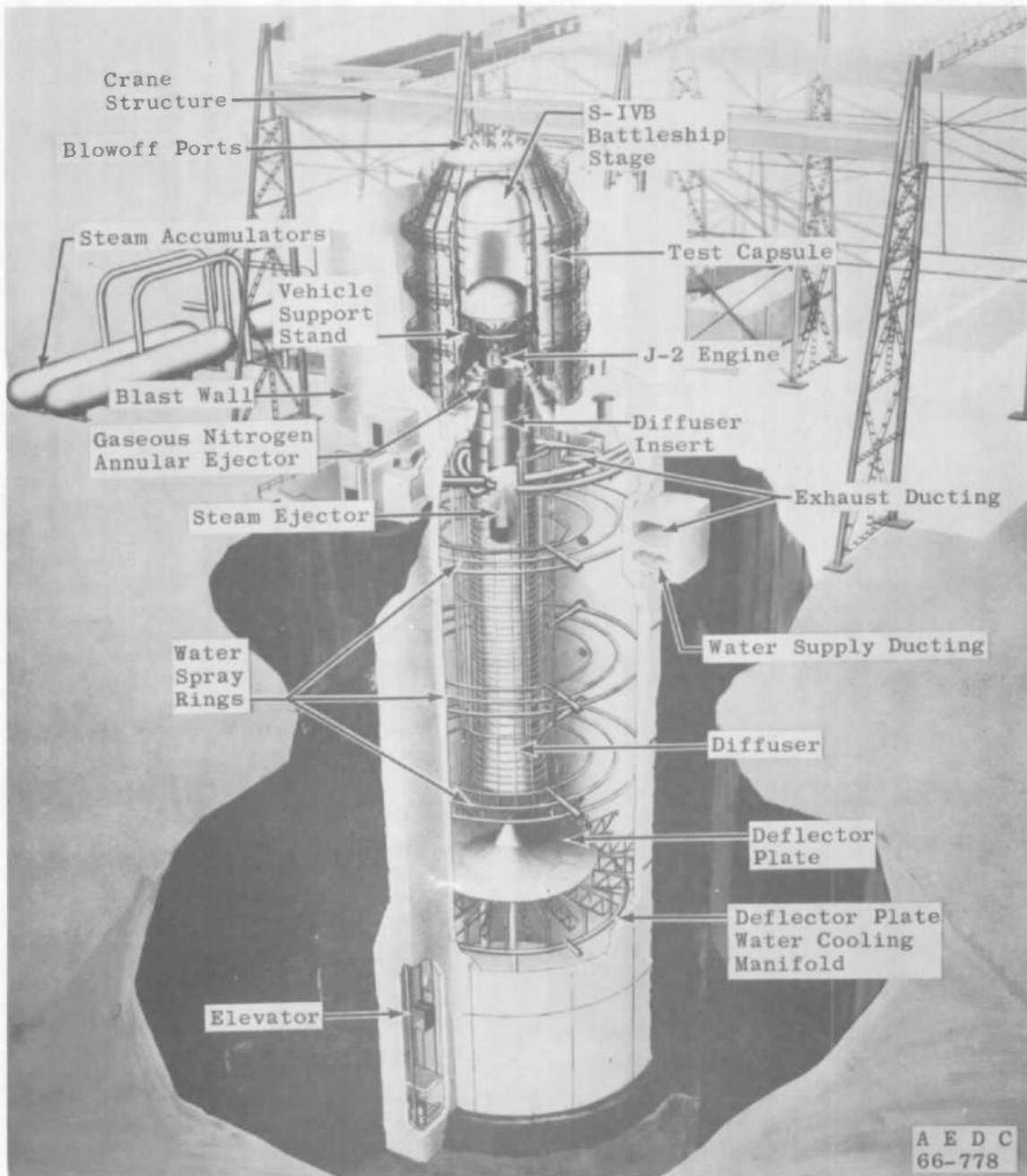

Fig. 2 Test Cell J-4 Artist's Conception

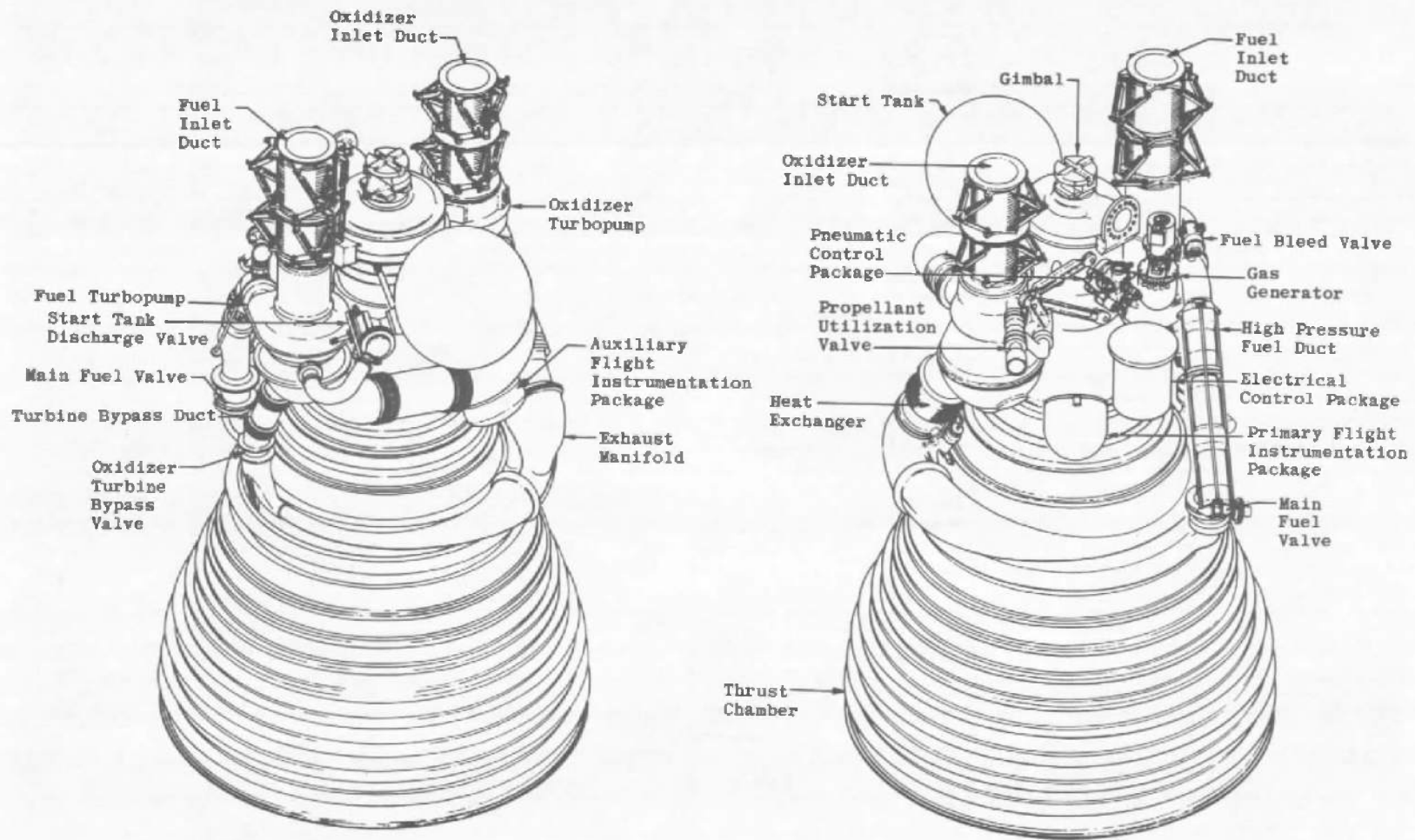

Fig. 3 Details of the J-2 Engine

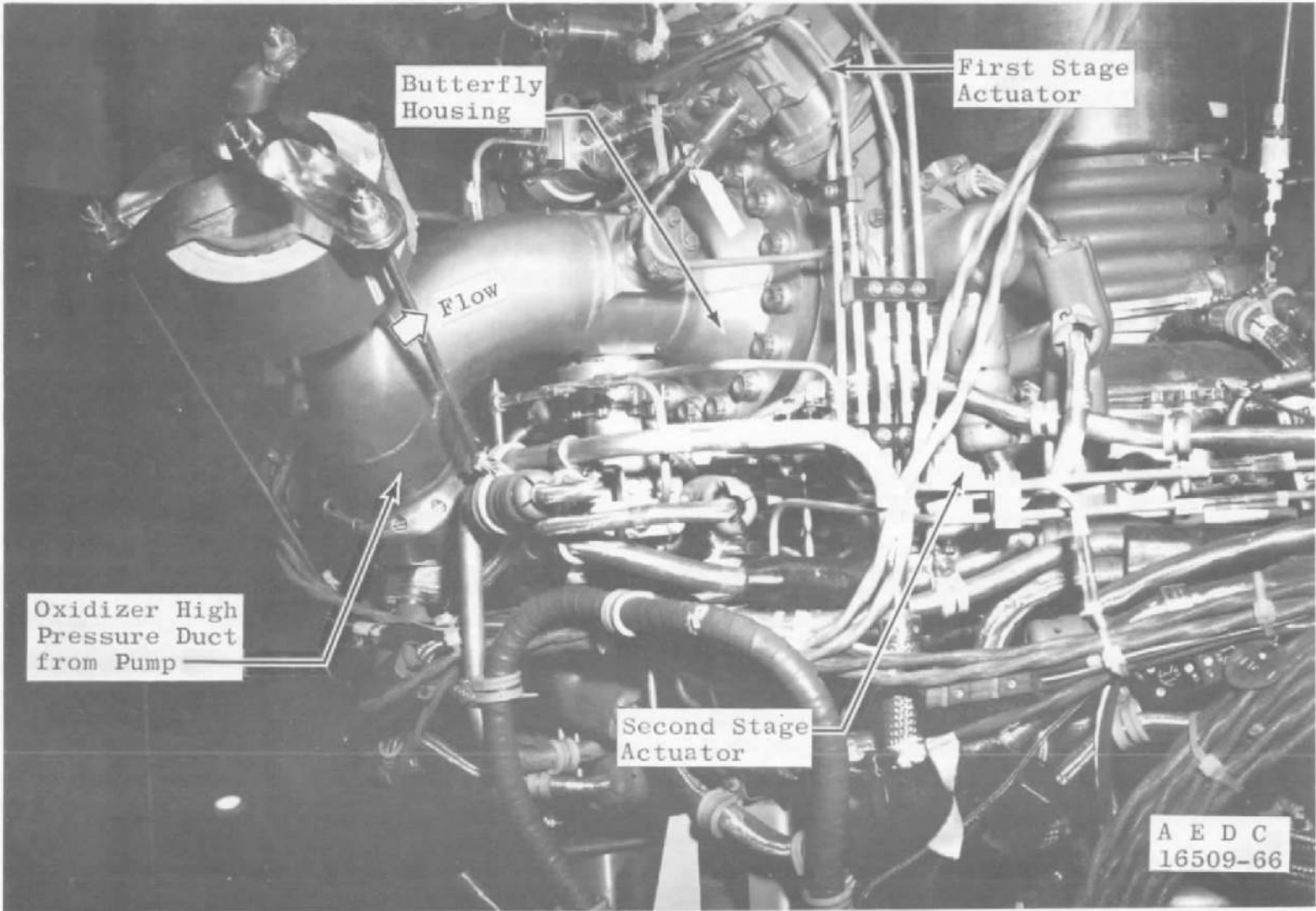

Fig. 4 Main Oxidizer Valve Installation

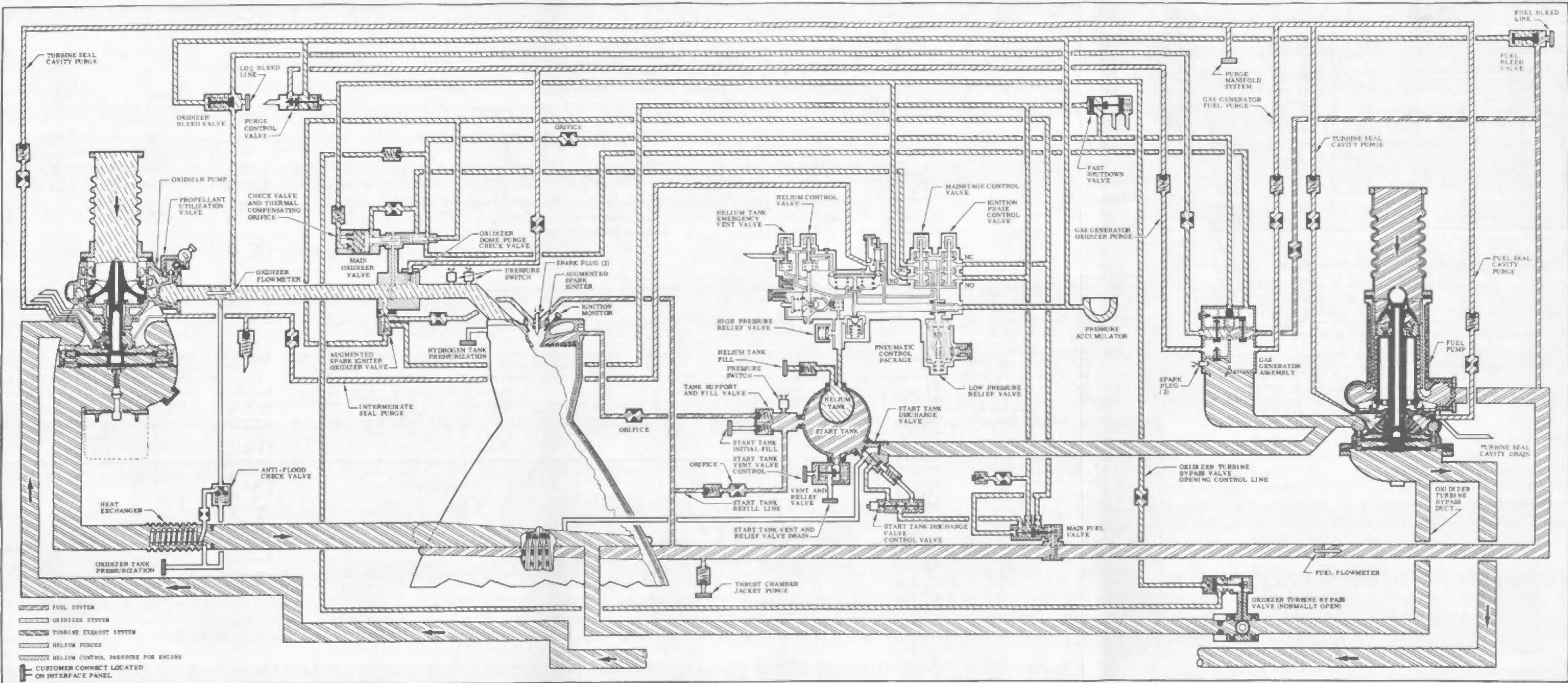

Fig. 5 J-2 Engine Schematic

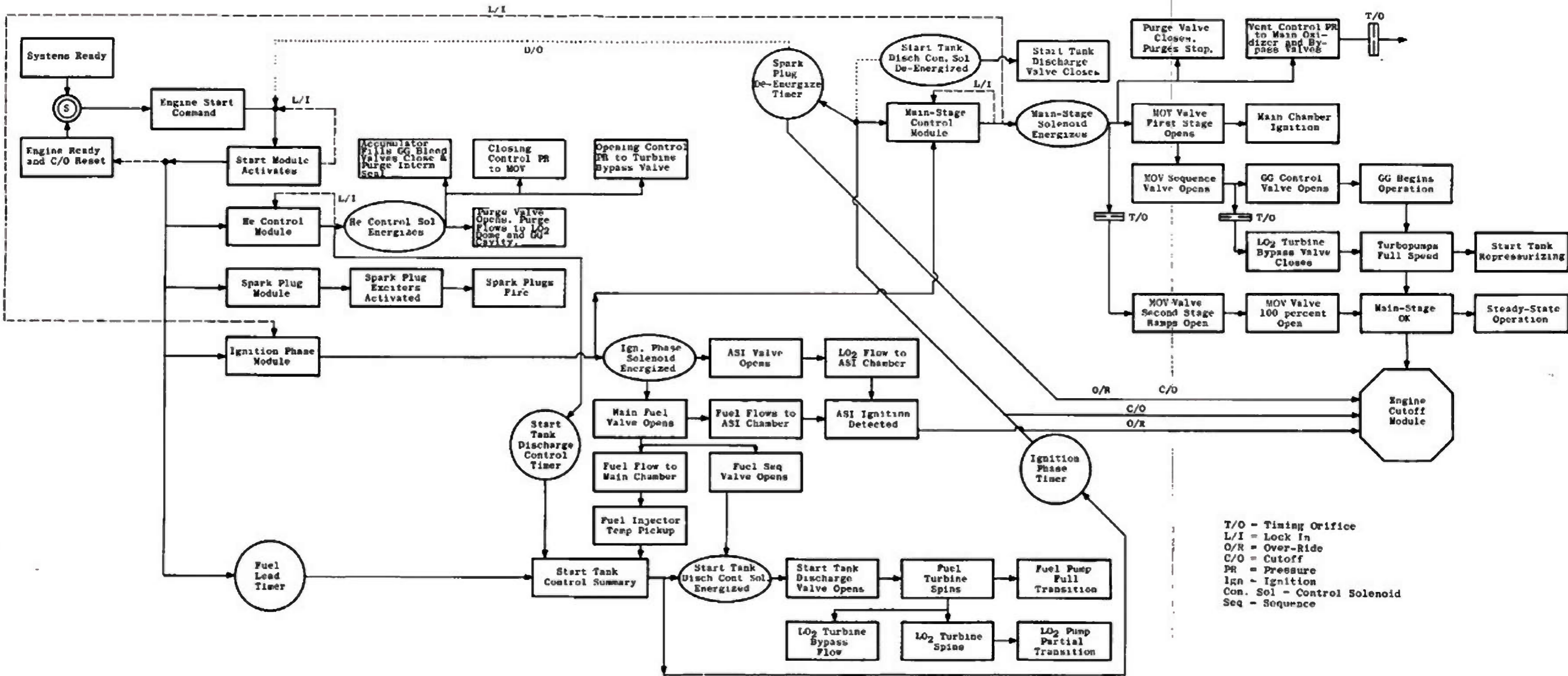
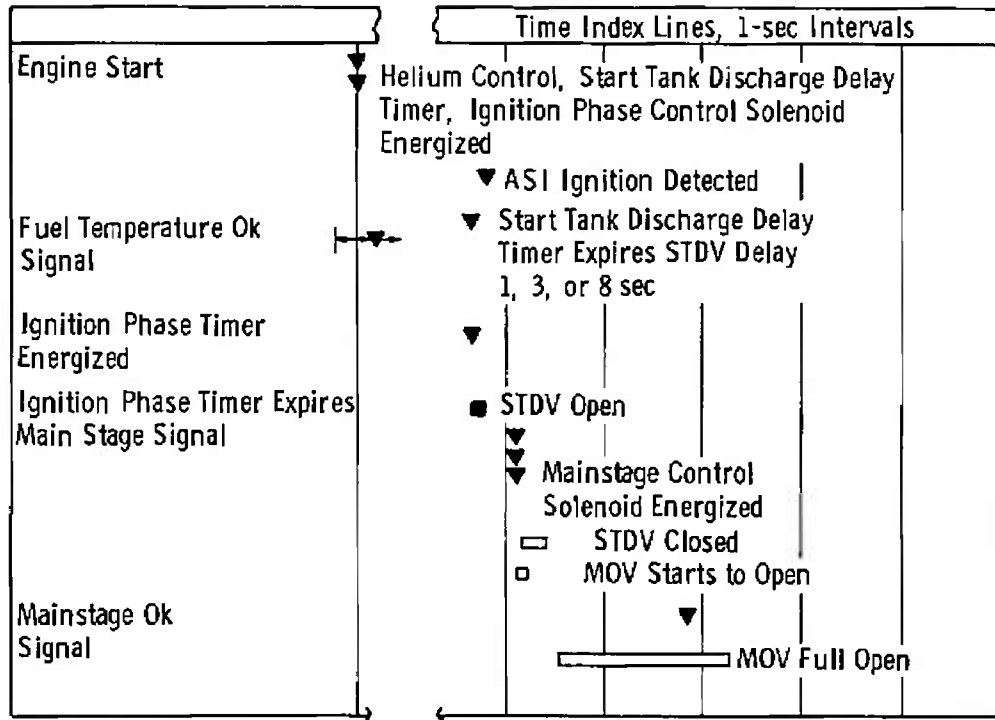
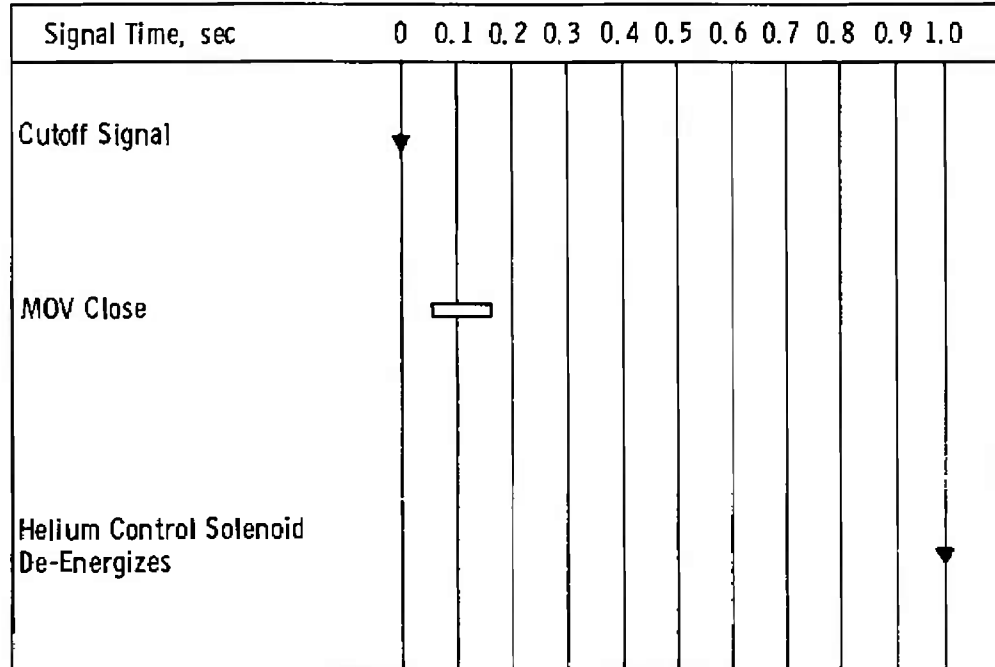

Fig. 6 J-2 Engine Start Logic Schematic



a. Start Sequence



b. Shutdown Sequence

Fig. 7 Start and Shutdown Sequence

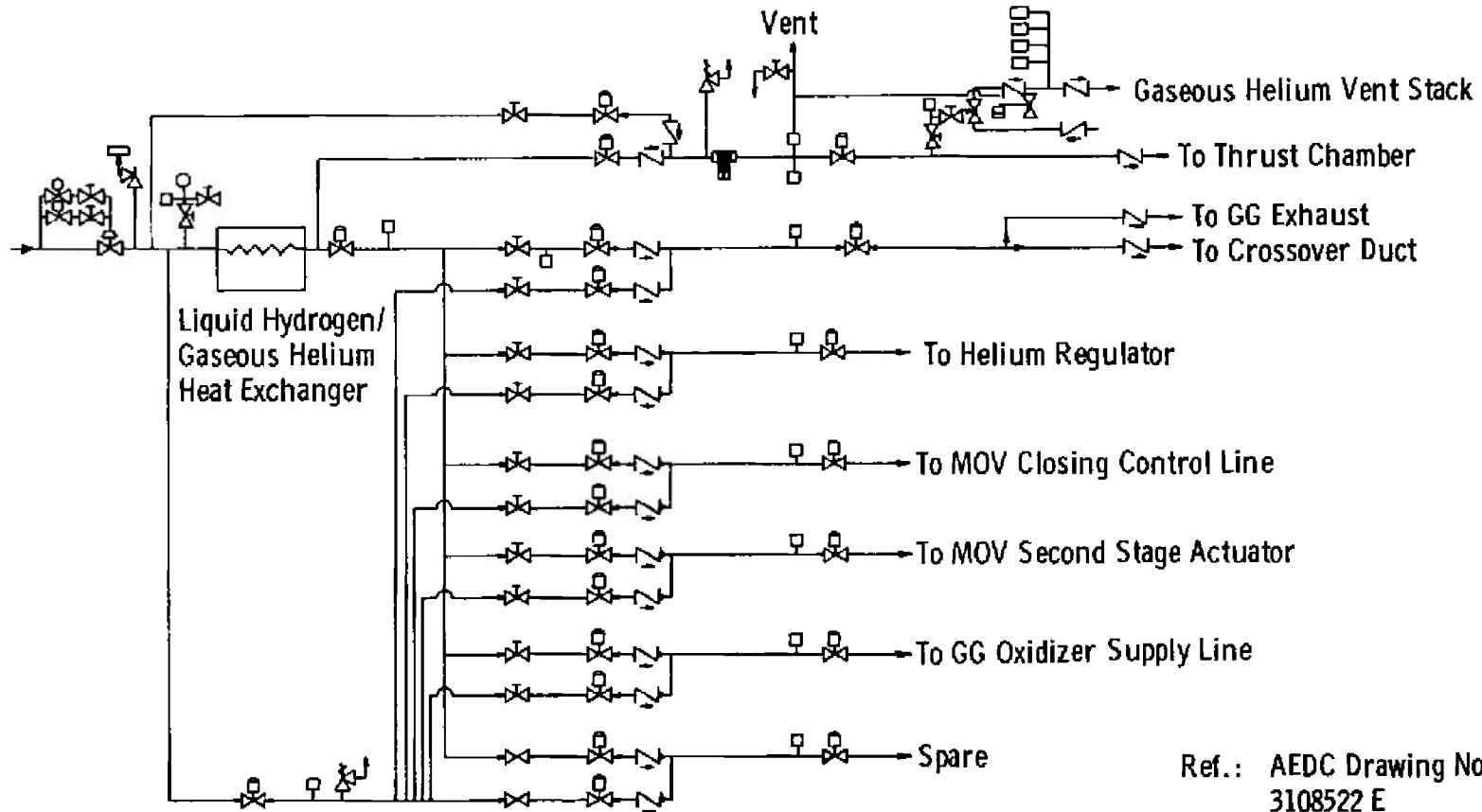

Key

- | | | | |
|--|------------------------|--|--------------------------|
| | Hand-Operated Valve | | Pressure Reduction Valve |
| | Pressure Control Valve | | Temperature Transducer |
| | Check Valve | | Pressure Transducer |

Ref.: AEDC Drawing No.
3108522 E
Sheet 6 of 6

Fig. 8 Thermal Conditioning System Schematic

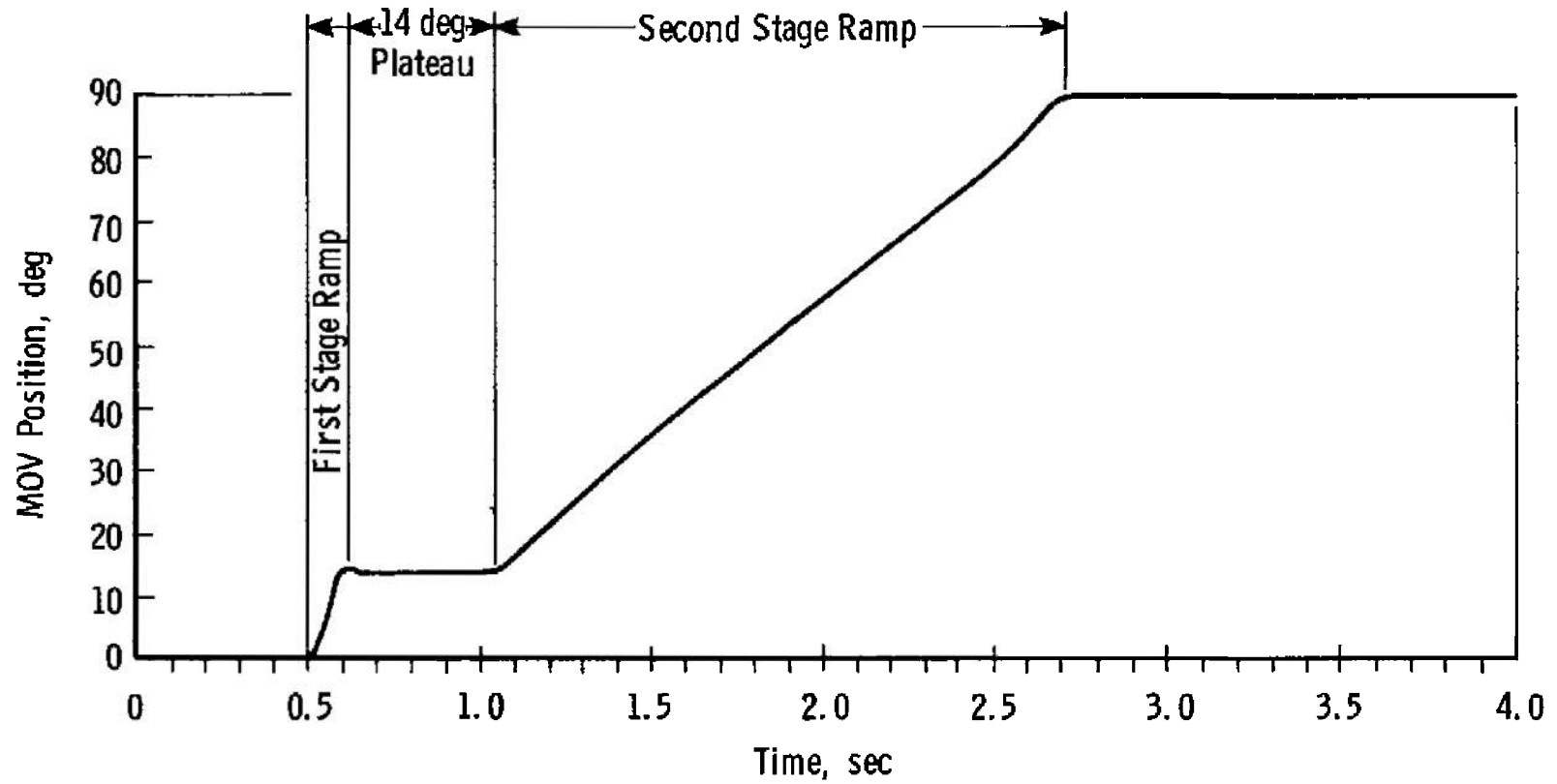

Fig. 9 Typical Main Oxidizer Valve Position Trace

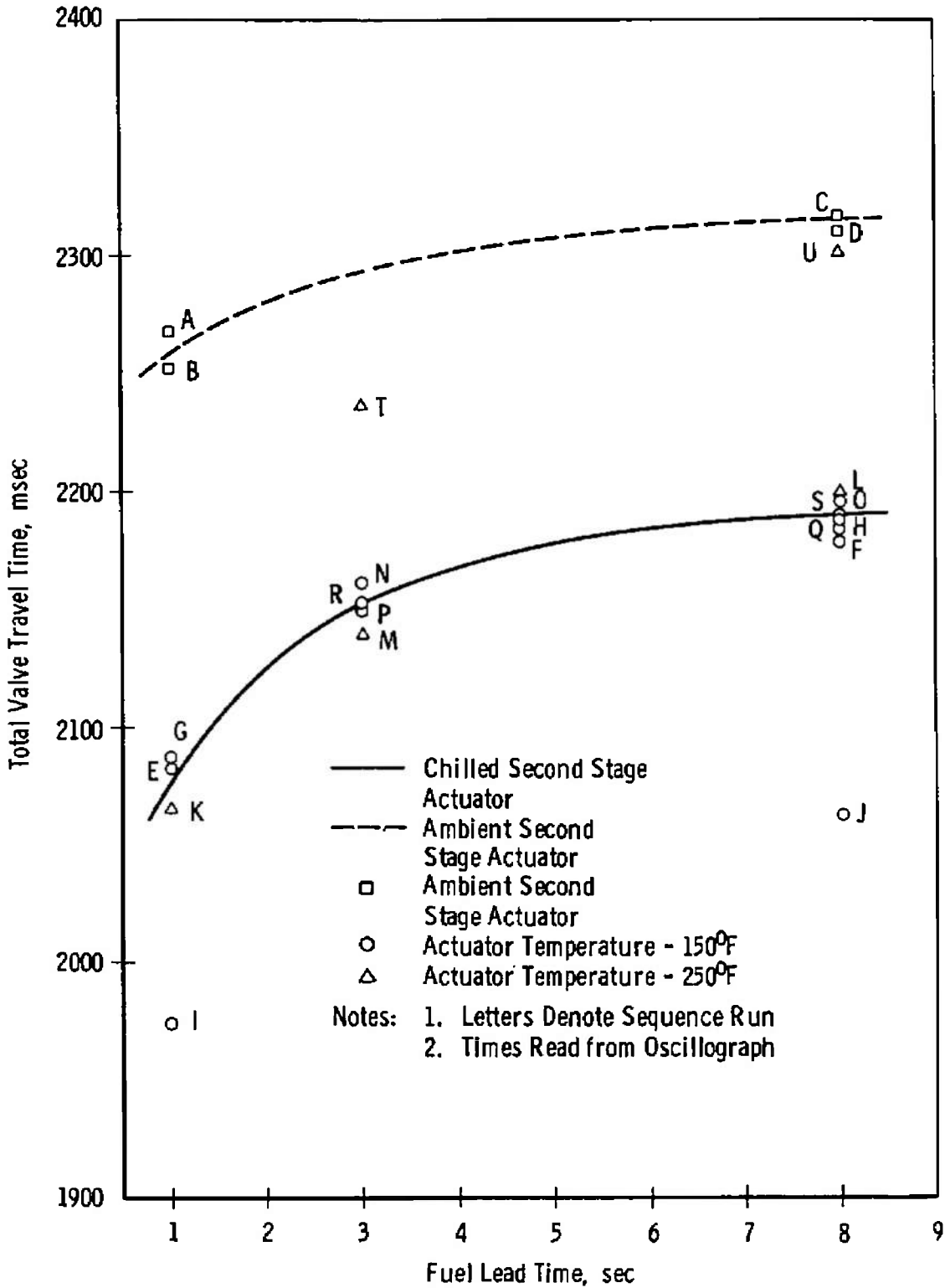

Fig. 10 Fuel Lead Time versus Valve Total Travel Time

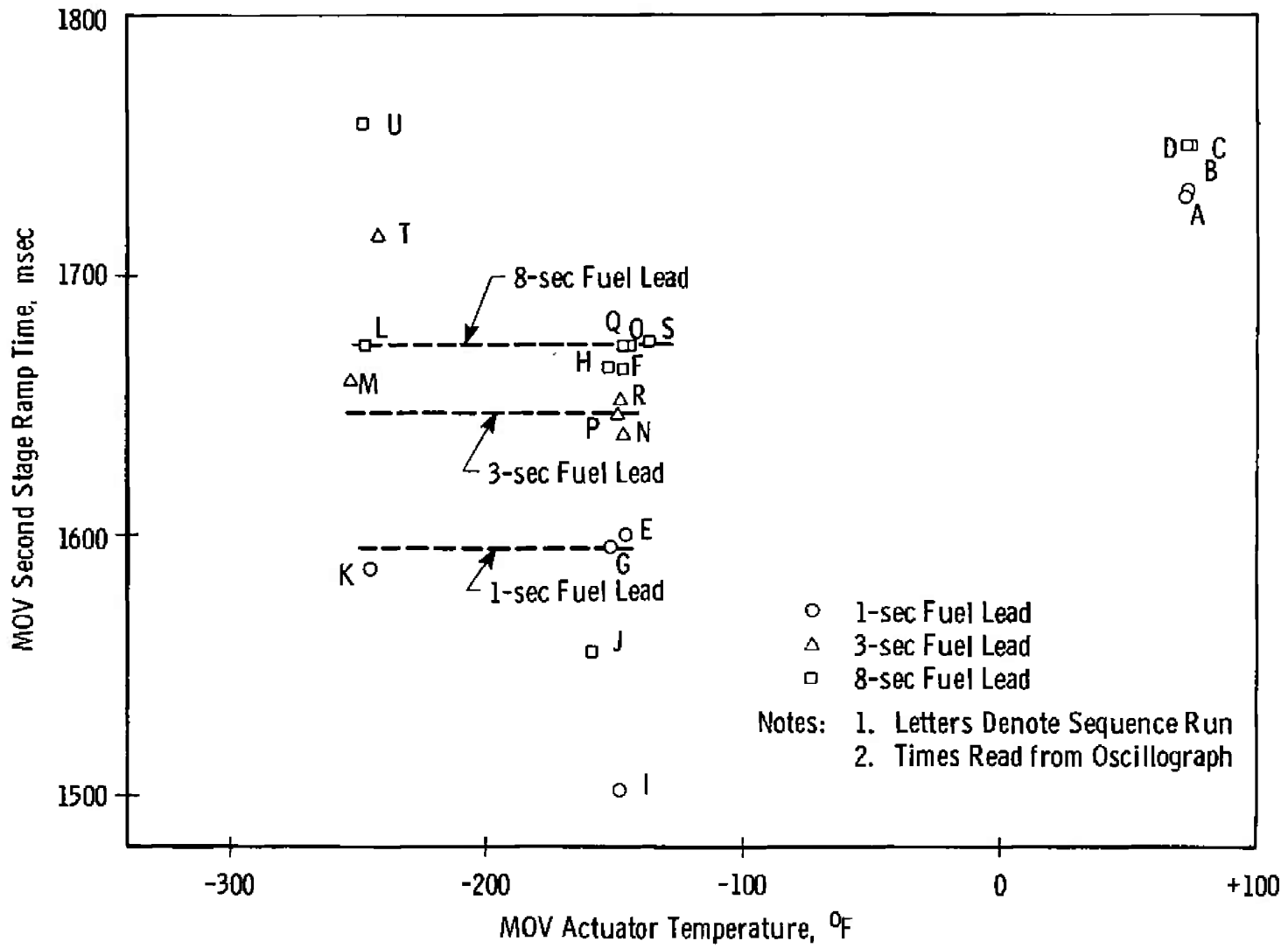

Fig. 11 Main Oxidizer Valve Second Stage Actuator Temperature versus Second Stage Ramp Time

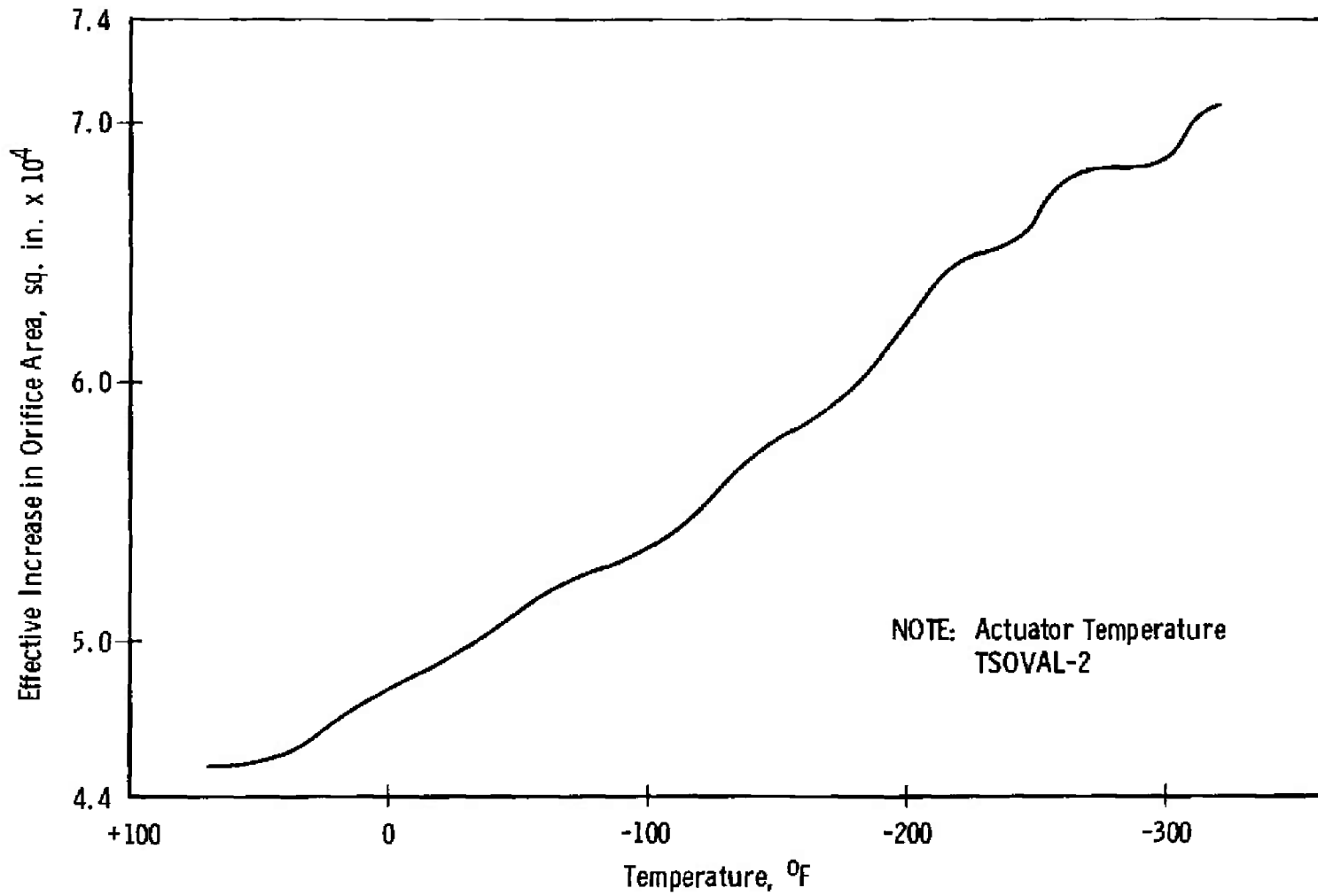

Fig. 12 Thermostatic Orifice Characteristics

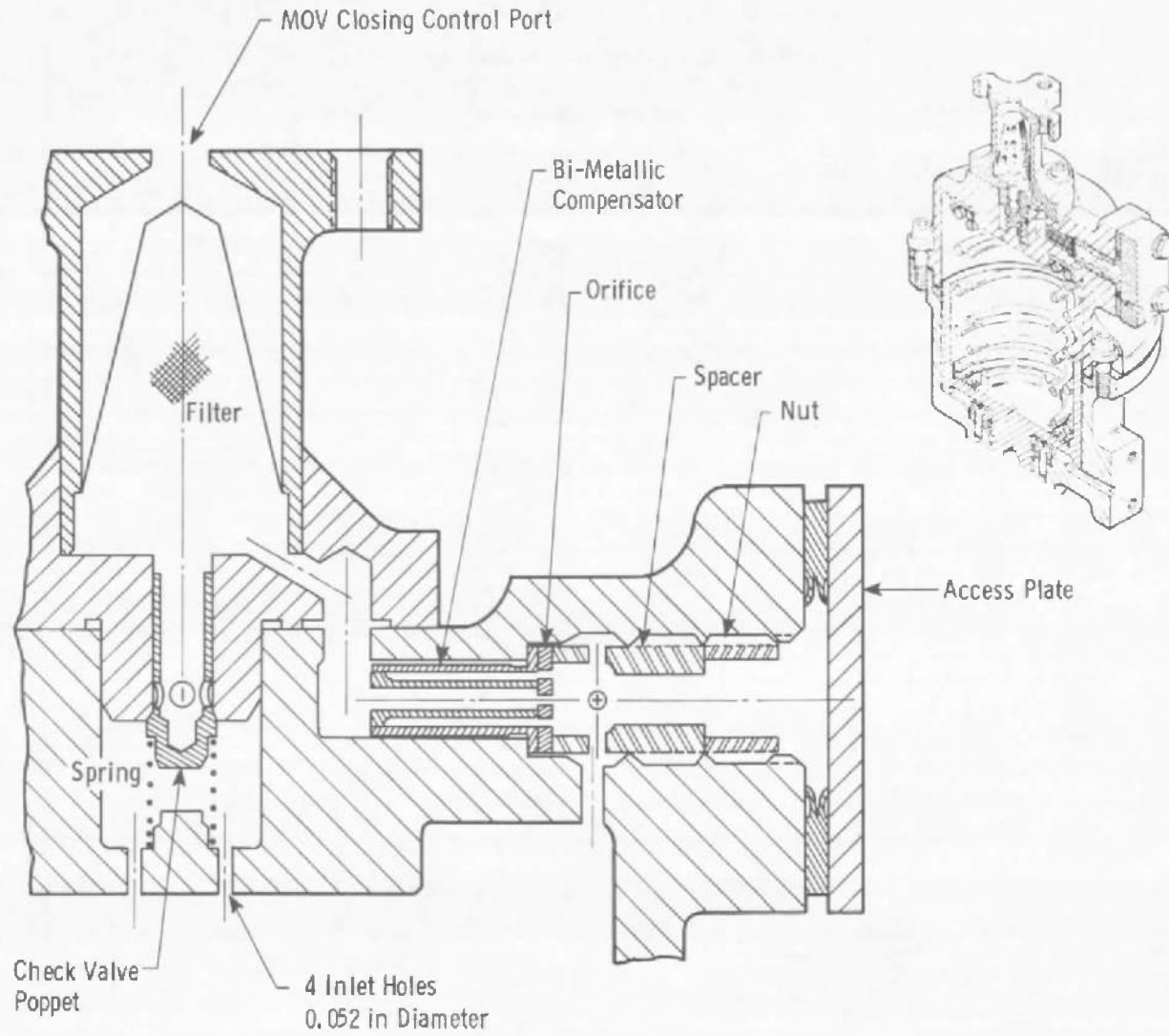

Fig. 13 Thermostatic Orifice Installation

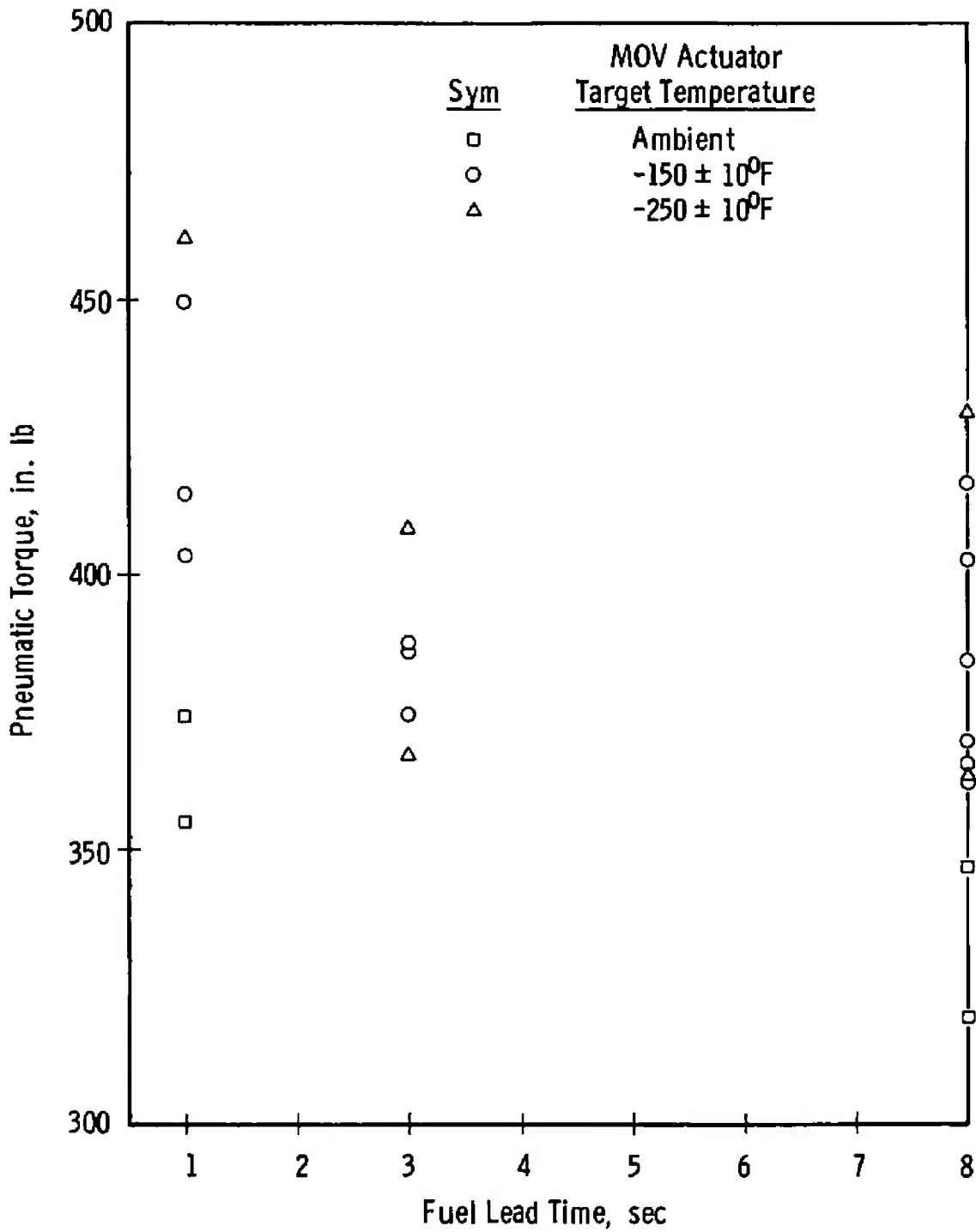

Fig. 14 Calculated Pneumatic Torque versus Fuel Lead Time

TABLE I
MAJOR J-2 ENGINE (S/N J-2052) COMPONENTS FOR TEST J4-1801-05

PART NAME	P/N	S/N
Thrust Chamber Body	206600-31	4076553
Thrust Chamber Injector Assembly	208021-11	4084917
Fuel Turbopump Assembly	459000-161	4062324
Oxidizer Turbopump Assembly	458175-71	6623549
Start Tank	303439	0064
Augmented Spark Igniter	206280-21	3661349
GG Fuel Injector and Combustor	308360-11	2008734
Helium Regulator Assembly	558130-141	4092999
Electrical Control Package	502670-11	4081748
Primary Flight Instr. Package	703685	4078716
Auxiliary Flight Instr. Package	703680	4078718
Main Fuel Valve	409120	4056924
Main Oxidizer Valve	411031	4089563
GG Control Valve	309040	4078714
Start Tank Discharge Valve	306875	4079062
Oxidizer Turbine Bypass Valve	409940	4048489
Prop. Utilization Valve	251351-11	4068944
Mainstage Control Valve	558069	8313568
Ignition Stage Control Valve	558069	8275775
Helium Control Valve	106012000	342270
Start Tank Vent and Relief Valve	557828-X2	4046446
Helium Tank Vent Valve	106012000	342277
Fuel Bleed Valve	309034	4077749
Oxidizer Bleed Valve	309029	4077746
ASI Oxidizer Valve	308880	4077205
P/A Purge Control Valve	557823	4073021
Start Tank Fill/Refill Valve	558000	4079001
Fuel Flowmeter	251225	4077752
Oxidizer Flowmeter	251216	4074114
Fuel Injector Temp. Transducer	NA5-27441	12401
Restartable Ignition Detect Probe	XEOR915389	211

TABLE II
ENGINE COMPONENT REPLACEMENTS (BETWEEN TEST J4-1801-04 AND TEST J4-1801-05)

MOD. NUMBER	COMPLETION DATE	DESCRIPTION OF MODIFICATION
UCR* 007970	August 14, 1967	Replacement of Helium Regulator Assembly

*UCR - Unsatisfactory Condition Report

TABLE III
SUMMARY OF TEST REQUIREMENTS AND RESULTS

Seq. No.	Fuel Lead Time, sec	MOV Actuator Temp., °F(3)		MOV Closing Control Line Temp., °F(3)		Helium(3) Regulator Temp., °F		Helium(4) Tank Temp., °F		Helium(4) Tank Pressure, psia		Conditioning Time, min
		Target ±10	Actual	Target ±10	Actual	Target ±10	Actual	Target ±10	Actual	Target -500 -0	Actual	
05A	1.006	(1)	72	(1)	75	(1)	75	(1)	91	1500	2194	---
05B	1.007	(1)	73	(1)	75	(1)	76	(1)	90	1500	2204	---
05C	7.996	(1)	74	(1)	75	(1)	77	(1)	88	1500	2204	---
05D	7.995	(1)	73	(1)	75	(1)	79	(1)	86	1500	2205	---
05E	1.010	-150	-146	(2)	61	(2)	54	-200	-193	1500	2471	30
05F	7.997	-150	-147	(2)	69	(2)	57	-200	-205	1500	2093	30
05G	1.010	-150	-152	(2)	-39	-150	-52	-200	-204	1500	1637	30
05H	8.000	-150	-153	(2)	-30	-150	-51	-200	-202	1500	1750	20
05I	1.008	-150	-148	-150	-146	-150	-151	-200	-204	1500	1739	20
05J	8.005	-150	-152	-150	-148	-150	-157	-200	-204	1500	1680	20
05K	1.007	-250	-245	-150	-151	-150	-154	-200	-205	1500	1792	30
05L	8.005	-250	-247	-150	-151	-150	-152	-200	-201	1500	1913	20
05M	3.007	-250	-253	-150	-153	-150	-152	-200	-203	1500	1792	20
05N	3.009	-150	-147	(2)	60	(2)	32	-200	-199	1500	1563	30
05O	7.995	-150	-144	(2)	68	(2)	31	-200	-205	1500	1832	30
05P	3.008	-150	-149	-150	-113	(2)	-44	-200	-202	1500	1781	30
05Q	8.007	-150	-147	-150	-134	(2)	-58	-200	-201	1500	1927	20
05R	3.003	-150	-148	-150	-136	-150	-134	-200	-192	1500	1974	20
05S	7.997	-150	-136	-150	-161	-150	-153	-200	-199	1500	1880	20
05T	3.005	-250	-242	-150	-157	-150	-148	-200	-199	1500	1728	30
05U	8.002	-250	-248	-150	-170	-150	-153	-200	-202	1500	1680	20

NOTES (1) No conditioning desired.
(2) Conditioned with ambient helium.
(3) Read at t_D .
(4) Helium tank read at engine start.

TABLE IV
MAIN OXIDIZER VALVE TIMING

Seq. No.	Start						Shutdown	
	MOV First Stage, Opening			MOV Second Stage, Opening			MOV Closing	
	Time of Opening Signal, sec	Valve Delay Time, sec	Valve Opening Time, sec	Time of Opening Signal, sec	Valve Delay Time, sec	Valve Opening Time, sec	Valve Delay Time, sec	Valve Closing Time, sec
A	0.447	0.047	0.046	0.447	0.587	1.730	0.066	0.130
B	0.447	0.050	0.050	0.447	0.585	1.733	0.064	0.128
C	0.446	0.052	0.050	0.446	0.616	1.750	0.060	0.130
D	0.448	0.052	0.048	0.448	0.612	1.750	0.066	0.130
E	0.447	0.055	0.056	0.447	0.530	1.600	0.077	0.174
F	0.446	0.053	0.059	0.446	0.570	1.665	0.075	0.175
G	0.445	0.050	0.053	0.445	0.545	1.595	0.070	0.170
H	0.444	0.050	0.059	0.444	0.571	1.665	0.074	0.167
I	0.440	0.050	0.053	0.440	0.522	1.502	0.070	0.168
J	0.439	0.053	0.053	0.439	0.559	1.555	0.075	0.172
K	0.439	0.055	0.053	0.439	0.533	0.587	0.086	0.200
L	0.440	0.055	0.063	0.440	0.585	1.673	0.080	0.207
M	0.439	0.055	0.065	0.439	0.542	1.660	0.080	0.206
N	0.440	0.051	0.058	0.440	0.567	1.648	0.072	0.171
O	0.440	0.053	0.058	0.440	0.577	1.673	0.070	0.176
P	0.440	0.053	0.059	0.440	0.555	1.647	0.072	0.171
Q	0.441	0.054	0.058	0.441	0.572	1.673	0.071	0.170
R	0.440	0.050	0.057	0.440	0.554	1.652	0.073	0.168
S	0.440	0.050	0.056	0.440	0.574	1.675	0.073	0.168
T	0.440	0.055	0.054	0.440	0.580	1.715	0.081	0.205
U	0.440	0.053	0.067	0.440	0.602	1.758	0.083	0.201

- Notes:
1. All valve signal times are referenced to t_0 .
 2. Valve delay time is the time required for initial valve movement after the valve "open" or valve "closed" solenoid has been energized.
 3. Data reduced from oscillograph.

**APPENDIX III
INSTRUMENTATION FOR TEST J4-1801-05**

The instrumentation for AEDC Test J4-1801-05 is tabulated in Table III-1. The location of selected major engine instrumentation is shown in Figs. III - 1a through d.

TABLE III-1
INSTRUMENTATION LIST

AEDC CODE	PARAMETER	TAP NO.	RANGE	MICROSADIC OSCILLOGRAPH	STRIP CHART	X-Y PLOTTER
	<u>Event</u>		<u>amp</u>			
ESTDCS	Start Tank Discharge Control Solenoid		on/off	x	x	
	<u>Position</u>		<u>o/o Open</u>			
LOVT	Main Oxidizer Valve		o to 100	x	x	
	<u>Pressure</u>		<u>psia</u>			
PA-3	Test Cell		0-5.0	x	x	
PFST-2	Fuel Start Tank	TF1	0-1500	x		x
PHET-2	Helium Tank	NN1	0-3500	x		x
PHRO-1A	Helium Regulator Outlet	NN2	0-750	x		
POVCC	Main Oxidizer Valve Closing Control		0-500	x		
	<u>Temperatures</u>		<u>°F</u>			
TBHR-1	Helium Regulator Body (North Side)		-100 to +50	x		
TBHR-2	Helium Regulator Body (South Side)		-100 to +50	x	x	
TFST-2	Fuel Start Tank	TFT1	-350 to +100	x		x
THET-1P	Helium Tank	NNT1	-350 to +100	x		x
TSOVAL-1	Oxidizer Valve Closing Control Line		-200 to +100	x		
TSOVAL-2	Oxidizer Valve Closing Control Line		-200 to +100	x	x	
TSOVC-1	Oxidizer Valve Actuator Cap		-325 to +150	x		
TSOVC-2	Oxidizer Valve Actuator Filter Flange		-350 to +150	x		
TSTDVCC	Start Tank Discharge Valve Closing Control Port		-350 to +100	x		
TSTDVOC	Start Tank Discharge Valve Opening Control Port		-350 to +100	x		

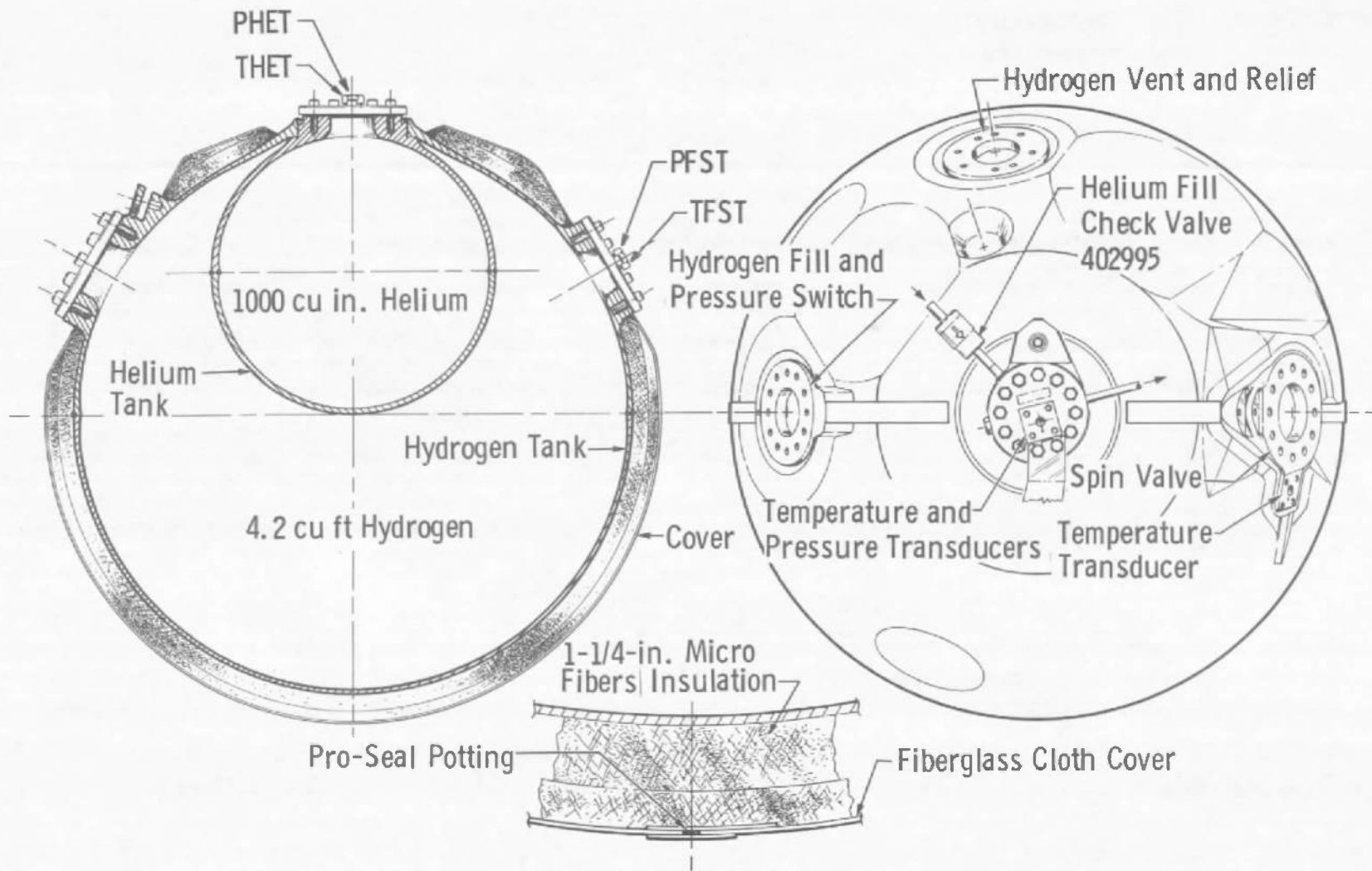

a. Start Tank and Helium Tank
Fig. III-1 Instrument Locations

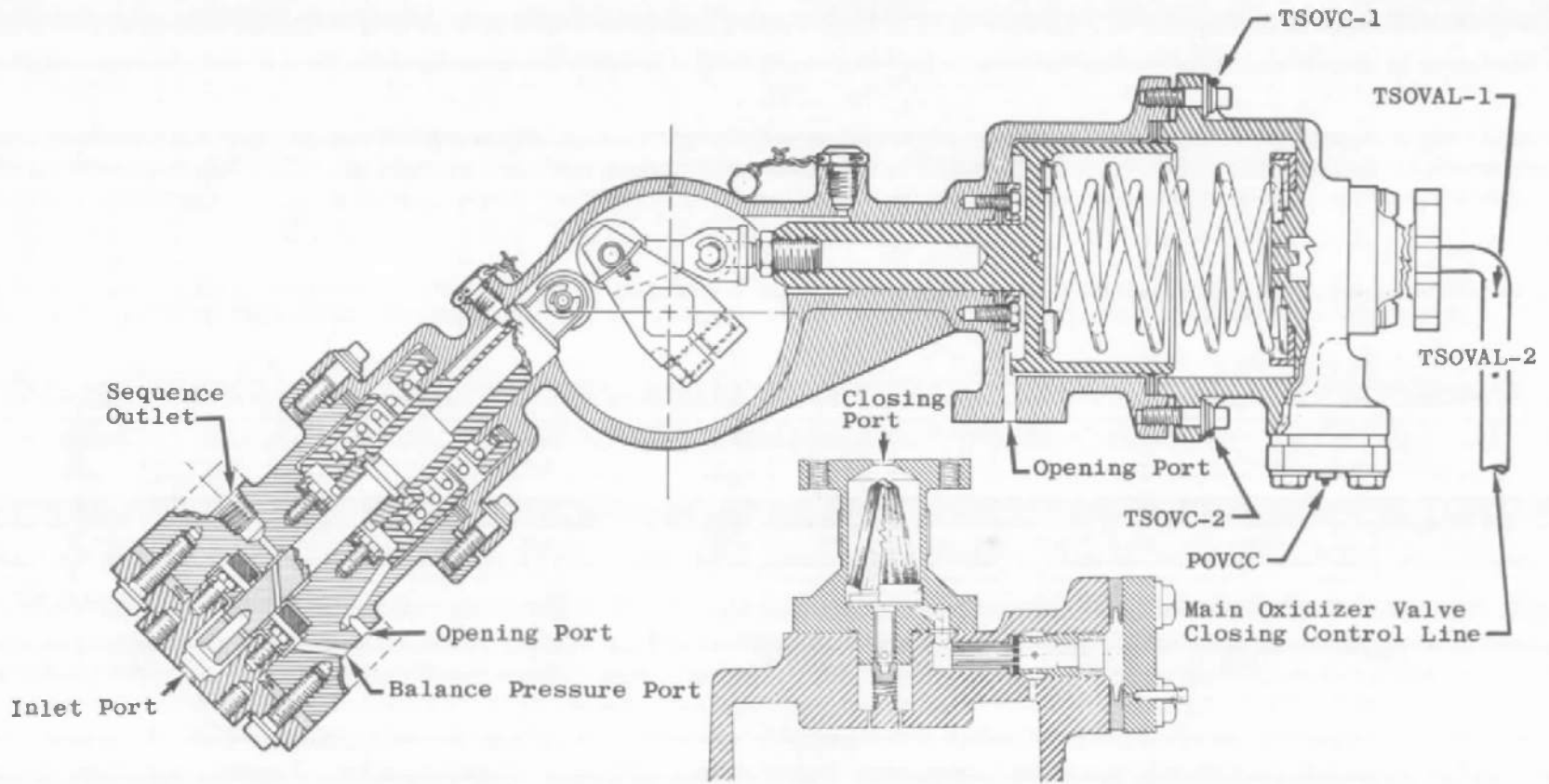

b. Main Oxidizer Valve
Fig. III-1 Continued

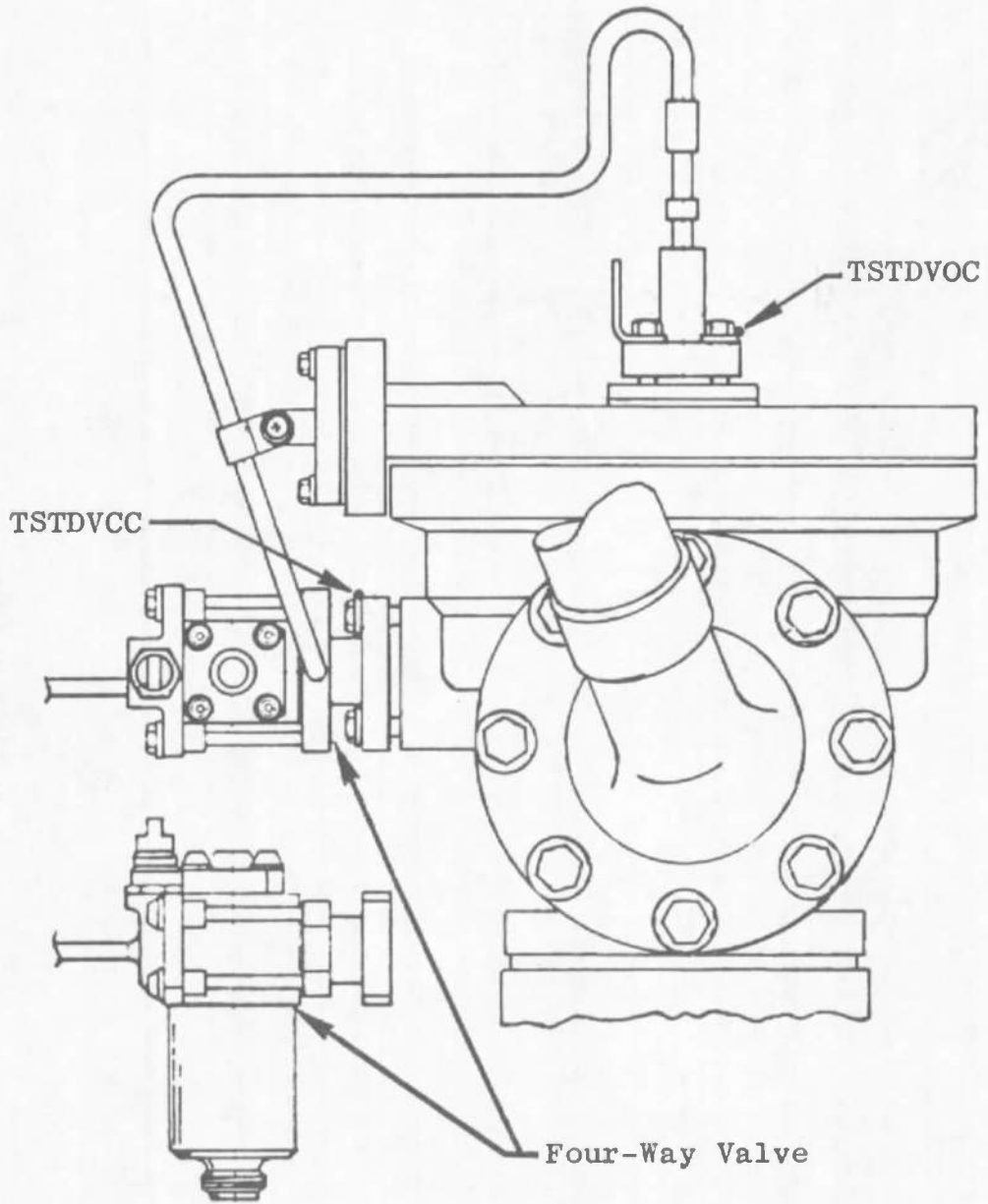

c. Start Tank Discharge Valve
Fig. III-1 Continued

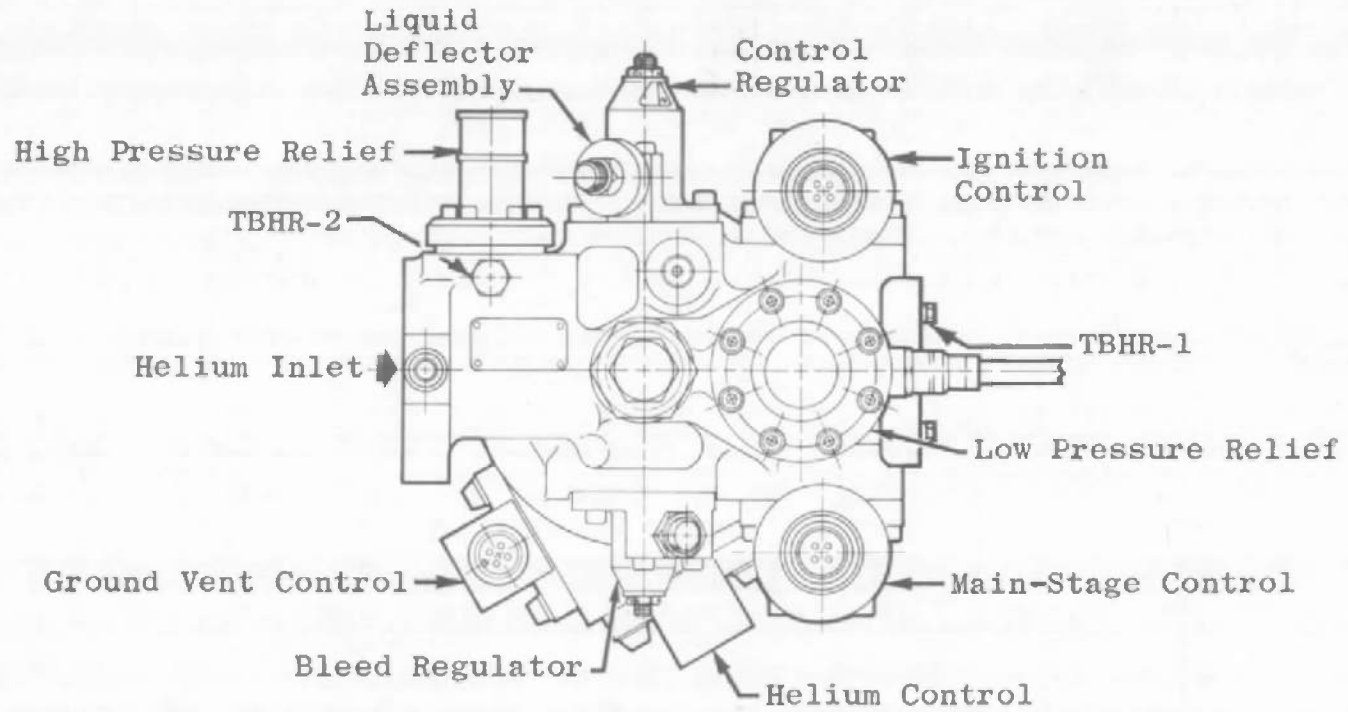

Top View

d. Helium Regulator
Fig. III-1 Concluded

Security Classification

DOCUMENT CONTROL DATA - R & D

(Security classification of title, body of abstract and indexing annotation must be entered when the overall report is classified)

1. ORIGINATING ACTIVITY (Corporate author) Arnold Engineering Development Center ARO, Inc., Operating Contractor Arnold Air Force Station, Tennessee		2a. REPORT SECURITY CLASSIFICATION UNCLASSIFIED	
		2b. GROUP N/A	
3. REPORT TITLE ALTITUDE DEVELOPMENTAL TESTING OF THE J-2 ROCKET ENGINE IN PROPULSION ENGINE TEST CELL (J-4) (TEST J4-1801-05)			
4. DESCRIPTIVE NOTES (Type of report and inclusive dates) Interim Report - August 15, 1967			
5. AUTHOR(S) (First name, middle initial, last name) H. J. Counts, ARO, Inc.			
6. REPORT DATE October 1967		7a. TOTAL NO. OF PAGES 38	7b. NO. OF REFS 2
8a. CONTRACT OR GRANT NO. AF40(600)-1200		9a. ORIGINATOR'S REPORT NUMBER(S) AEDC-TR-67-208	
b. PROJECT NO. 9194		9b. OTHER REPORT NO(S) (Any other numbers that may be assigned this report) N/A	
c. System 921E			
d.			
10. DISTRIBUTION STATEMENT Subject to special export controls; transmittal to foreign governments or foreign nationals requires approval of NASA Marshall Space Flight Center (I-E-J), Huntsville, Alabama. Each transmittal of this document outside the Department of Defense must have*			
11. SUPPLEMENTARY NOTES Available in DDC		12. SPONSORING MILITARY ACTIVITY National Aeronautics and Space Adm. Marshall Space Flight Center (I-E-J) Huntsville, Alabama	
13. ABSTRACT Twenty-one valve sequence operations of the Rocketdyne J-2 engine were conducted on August 15, 1967 in Propulsion Engine Test Cell (J-4) of the Large Rocket Facility, Arnold Engineering Development Center. The tests were accomplished during test period J4-1801-05 at local atmospheric pressure conditions to evaluate the effects of thermal conditioning on the main oxidizer valve operation. Fuel lead times of 1, 3, and 8 sec were simulated by varying the time between engine start and start tank discharge valve control solenoid energized. Engine components which were thermally conditioned included the (1) helium tank, (2) helium regulator, (3) main oxidizer valve closing control line, and (4) main oxidizer valve second stage actuator. This document is subject to special export controls and each transmittal to foreign governments or foreign nationals may be made only with prior approval of NASA Marshall Space Flight Center (I-E-J), Huntsville, Alabama.			
*prior approval of NASA Marshall Space Flight Center (I-E-J), Huntsville Alabama.			

KEY WORDS

LINK A

LINK B

LINK C

ROLE

WT

ROLE

WT

ROLE

WT

J-2 rocket engine
 altitude testing
 thermal conditioning
 main oxidizer valve
 Apollo

- 1. Rocket motors -- J2.
- 2 " " -- Thermal conditioning
- 3 " " -- Performance
- 4 Valves -- Thermal conditioning

16-3