

UNCLASSIFIED

AD NUMBER

AD824098

LIMITATION CHANGES

TO:

Approved for public release; distribution is unlimited.

FROM:

Distribution authorized to U.S. Gov't. agencies and their contractors;
Administrative/Operational Use; DEC 1967. Other requests shall be referred to Air Force Aero-Propulsion Lab., Wright-Patterson AFB, OH 45433.

AUTHORITY

AFAPL ltr 12 Apr 1972

THIS PAGE IS UNCLASSIFIED

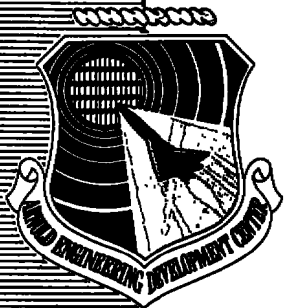

**EXPERIMENTAL PERFORMANCE
OF A HALL MAGNETOHYDRODYNAMIC
ELECTRIC POWER GENERATOR**

**R. J. LeBoeuf and J. D. McNeese
ARO, Inc.**

December 1967

This document is subject to special export controls and each transmittal to foreign governments or foreign nationals may be made only with prior approval of Air Force Aero-Propulsion Laboratory (APIE-2), Wright-Patterson AFB, Ohio.

**ROCKET TEST FACILITY
ARNOLD ENGINEERING DEVELOPMENT CENTER
AIR FORCE SYSTEMS COMMAND
ARNOLD AIR FORCE STATION, TENNESSEE**

NOTICES

When U. S. Government drawings specifications, or other data are used for any purpose other than a definitely related Government procurement operation, the Government thereby incurs no responsibility nor any obligation whatsoever, and the fact that the Government may have formulated, furnished, or in any way supplied the said drawings, specifications, or other data, is not to be regarded by implication or otherwise, or in any manner licensing the holder or any other person or corporation, or conveying any rights or permission to manufacture, use, or sell any patented invention that may in any way be related thereto.

Qualified users may obtain copies of this report from the Defense Documentation Center.

References to named commercial products in this report are not to be considered in any sense as an endorsement of the product by the United States Air Force or the Government.

EXPERIMENTAL PERFORMANCE
OF A HALL MAGNETOHYDRODYNAMIC
ELECTRIC POWER GENERATOR

R. J. LeBoeuf and J. D. McNeese
ARO, Inc.

This document is subject to special export controls and each transmittal to foreign governments or foreign nationals may be made only with prior approval of Air Force Aero-Propulsion Laboratory (APIE-2), Wright-Patterson AFB, Ohio.

FOREWORD

The test program reported herein was conducted at the request of the Aeronautical Systems Division (ASD), Air Force Aero-Propulsion Laboratory (AFAPL), Air Force Systems Command (AFSC), Wright-Patterson Air Force Base, Ohio, for the University of Tennessee Space Institute (UTSI) under Program Element 62405214, Project 5350, Task 535004, Contract AF33(615)-2691.

The results of the test were obtained by ARO, Inc. (a subsidiary of Sverdrup & Parcel and Associates, Inc.), contract operator of the Arnold Engineering Development Center (AEDC), AFSC, Arnold Air Force Station, Tennessee, under Contract AF40(600)-1200. The test was conducted in Propulsion Research Area (R-2C-4) of the Rocket Test Facility (RTF) under ARO Project No. RW0637 from February 28 until May 24, 1967, and the manuscript was submitted for publication on October 25, 1967.

Information in this report is embargoed under the Department of State International Traffic in Arms Regulations. This report may be released to foreign governments by departments or agencies of the U. S. Government subject to approval of Air Force Aero-Propulsion Laboratory (APIE-2), or higher authority within the Department of the Air Force. Private individuals or firms require a Department of State export license.

This technical report has been reviewed and is approved.

Joseph R. Henry
Lt Col, USAF
AF Representative, RTF
Directorate of Test

Leonard T. Glaser
Colonel, USAF
Director of Test

ABSTRACT

A test program was conducted on a Hall Magnetohydrodynamic generator. The internal dimensions of the generator channel diverged from 4 in. in height at the channel inlet to 6 in. in height at the channel exit, and the width was 2 in. along the 48-in. length of the channel. The plasma was provided by a gaseous oxygen/RP-1 combustor with a Mach number 1.6 nozzle. The propellants were seeded with potassium hydroxide (KOH) dissolved in ethyl alcohol to produce a high ion concentration in the exhaust stream. The generated power was dissipated through a resistor load bank with a variety of parallel and series resistance configurations. Operating conditions were nominally as follows: combustor chamber pressure, 46 psia; KOH concentration, 1.3 percent of total propellant weight flow; magnetic field, 20,000 gauss; and load bank resistance, from 0 to 24.9 ohms. Tabulations of combustor performance data and of the generator electrical data are presented.

This document is subject to special export controls and each transmittal to foreign governments or foreign nationals may be made only with prior approval of Air Force Aero-Propulsion Laboratory (APIE-2), Wright-Patterson AFB, Ohio.

CONTENTS

	<u>Page</u>
ABSTRACT	iii
I. INTRODUCTION	1
II. APPARATUS	2
III. PROCEDURE	7
IV. RESULTS AND DISCUSSION	7
REFERENCES	11

APPENDIXES

I. ILLUSTRATIONS

Figure

1. Pre-Fire Photograph of Hall Channel	15
2. Schematic of Hall Channel Segment	16
3. Electromagnet	
a. Photograph, Looking Upstream	17
b. Photograph, Looking Downstream	17
c. Coil Electrical Schematic	18
4. Magnet Field Strength as a Function of Current	19
5. Photograph of Magnet Power Supplies	20
6. Photographs of Load Bank Unit	
a. Front View	21
b. Top View	22
7. Schematic of Combustor	23
8. Photograph of Injector	24
9. Photographs of Water-Cooled Exhaust Nozzle Assembly	
a. Looking Downstream	25
b. Looking Upstream	26
10. Igniter Assembly	
a. Photograph	27
b. Schematic	28
11. Installation of MHD Generator Assembly in Propulsion Research Area (R-2C-4)	
a. Photograph	29
b. Schematic	29

<u>Figure</u>	<u>Page</u>
12. Photograph of Spray Chamber	30
13. Schematics of Hall Channel Electrical Circuit	
a. Without Instrumentation	31
b. With Instrumentation	32
14. Photograph of Shunt Panel	33
15. Schematic of Propellant System	34
16. Photograph of Meter Panel	35
17. Typical Engine Ignition Transient	36
18. Combustor Chamber Pressure and Seed and Propellant Flow Rates during a Typical Firing	37
19. Generated Power as a Function of Load Resistance	
a. Test Series 59 through 63 (R_C between Elements 5 and 57)	38
b. Test Series 64 through 69 (R_C between Elements 3 and 58)	38
20. Chamber Pressure, Total Voltage, and Total Current during a Typical Firing	39
21. Schematic of High-Speed Camera Installation	40
22. Photographs Showing Electrode Arc "Spot" Crossing Cathode Surface	41
23. Post-Fire Photographs of Hall Channel	
a. Overall View	43
b. Damage Caused by Arcing	44
c. Detailed View Showing Mica Paper Insulation Damage	45
 II. TABLES	
I. Instrumentation	46
II. Summary of Operating Conditions	47
III. Summary of Combustor Performance	49
IV. Summary of Measured Load Bank Resistances	51
V. Summary of Channel Electrical Measurements	
a. Channel-to-Load Bank	53
b. Element Top-to-Element Bottom	55
c. Load Bank Voltages	59

SECTION I INTRODUCTION

A magnetohydrodynamic (MHD) electric power generator is classed as a direct energy conversion device. Ionized gas flowing at high velocity through a channel is acted upon by a transverse magnetic field to produce an electromotive force (emf) perpendicular to the velocity vector and the magnetic field vector. The same physical principles are involved in an MHD generator as in a conventional generator except that conducting gases replace the metallic conductors of the rotor.

The University of Tennessee Space Institute (UTSI) is currently engaged in a research investigation of parameters governing the performance of open-cycle MHD devices. The program is designed to provide correlation between theoretical and experimental performance of several types of MHD generators in order to establish basic generator design criteria. The scope of the experimental effort includes a parametric study to optimize the performance of 45-, 60-, and 75-deg-slant, Hall, and Faraday generator channels operating at various gas dynamic conditions, electrical loads, and magnetic fields. The walls of each of the channels are segmented to reduce the effect of the Hall field.

The test program reported herein was conducted in Propulsion Research Area (R-2C-4) of the Rocket Test Facility (RTF). The RTF personnel were responsible for design and fabrication of the combustor and associated propellant, instrumentation, and exhaust systems. The channel, magnet, diffuser, load banks, and electric meters were supplied by UTSI.

This report presents the data obtained from the Hall, segmented wall MHD generator phase of testing. A description of the combustor, channel, magnet, and associated systems is given, and the methods used to obtain the required measurements are presented. Results of earlier test programs which utilized Hall, 45-deg-slant, and 60-deg-slant MHD generator channels are presented in Refs. 1 through 3.

SECTION II APPARATUS

2.1 TEST ARTICLE

The test article consisted of a combustor, a Hall MHD generator channel and diffuser, a magnet, and supporting systems. These components are described in detail in the sections to follow.

2.1.1 MHD Generator

The channel (Fig. 1, Appendix I) is nominally 48 in. long with outside dimensions of 3.75 in. wide by 8 in. high. The inside dimensions are 2 in. wide by 4 in. high at the inlet with the side walls parallel and the top and bottom walls diverging to 6 in. high at the exit. The 36-in. active portion of the channel (conforming to the 36- by 6-in. magnetic field cross section) is assembled from several individually insulated wall segments, each segment acting as an electrode. The remaining 12 in. of channel length (nominally 6 in. at each end) is made of copper blocks (transition elements) insulated from each other to reduce eddy currents. Each element and block is attached to the adjacent elements and blocks by ceramic-insulated, stainless steel screws.

The channel segments (Fig. 2) are 0.582-in.-thick copper slabs electrically insulated from each other by 0.018-in.-thick mica paper, and arranged perpendicular to the axis of the channel. The segments are split at the middle to form top and bottom elements, also insulated from each other. The 60 segments, with insulation, comprise the 36-in. active length of the channel.

The diffuser is made from 0.5-in. stainless steel, 2 by 6 in. in cross section and 24.5 in. in length. The diffuser adapts to the forward bulkhead of the spray chamber with a rubber slip joint seal and extends 8 in. into the spray chamber.

2.1.2 Magnet

The magnetic field is provided by a 20,000-gauss electromagnet (Fig. 3) and is directed normal to the vertical plane containing the axis of the channel. The distance between the magnet pole faces is 3.96 in.; each face is 6 in. high by 36 in. long.

The magnet is of "C" frame construction with eight strip-wound coils; six coils have 48 turns each, and two coils have 55 turns each. Each coil is designed to conduct 600 amp for a total of 238,800 ampere turns. The magnetic field strength is presented in Fig. 4 as a function of current. Water cooling coils are installed adjacent to, but insulated from, the electrical coils. Cooling water is supplied at a rate of from 50 to 60 gal/min at a nominal inlet pressure of 70 psig. In case of accidental power failure, the energy stored in the magnetic field is dissipated through a 0.040-in. spark gap located in the electrical terminal box (Fig. 3a).

Electric power to the magnet is supplied by fifteen 400-amp, 40-v, dc power supplies connected in five parallel arrays of three each in series (Fig. 5).

2.1.3 Load Bank

The electric power generated by the MHD channel is dissipated as heat through four air-cooled load banks, each containing two hundred and fifty-two 1.4-ohm heater element resistors (Fig. 6). Each load bank is capable of dissipating 100 kw. The individual resistors are connected to form the desired parallel and series arrangements for impedance matching to the channel electrical output.

2.1.4 Combustor

Ionized gas to the MHD generator is provided by a gaseous oxygen (GO_2)/RP-1 combustor (Fig. 7) operating at a chamber pressure of 46 psia and at a nominal oxidizer-to-fuel ratio of 2.8. A seeding agent consisting of a saturated solution of potassium hydroxide (KOH) in MIL-A-6091 ethyl alcohol (21-percent KOH by weight) is injected into the RP-1 upstream of the combustor to increase the exhaust gas electrical conductivity.

The propellants are injected into the chamber through a 0.9-in. -thick, stainless steel injector (Fig. 8). The RP-1/seed solution is injected through 0.04-in. -diam orifices located on radii of 0.63 in. (four orifices) and 2.75 in. (eight orifices) on the injector face. The RP-1 is injected axially through the inner ring orifices and inward at an angle of 30 deg to the combustor centerline through the outer ring orifices. The GO_2 is injected through fifty 0.22-in. -diam orifices located on three concentric rings between the inner and outer RP-1/seed spray rings. Combustor chamber pressure is measured through an orifice in the injector face.

The 7.0-in. -diam by 14.0-in. -long, water-cooled combustion chamber was fabricated from 347 stainless steel. The chamber cooling-water flow rate was nominally 30 lb_m/sec, which provided a water velocity through the cooling passage of 17 ft/sec with a water temperature rise during firing of approximately 7°F.

A water-cooled, stainless steel exhaust nozzle (Fig. 9) is bolted to the downstream end of the combustion chamber. The circular-to-rectangular cross-sectional transition is accomplished in the converging subsonic nozzle section upstream of the throat. The contoured supersonic section diverges from 2.0 by 3.1 in. at the throat to 2.0 by 4.0 in. at the exit, providing an area ratio of 1.37 and a nominal exit Mach number of 1.6. The nozzle cooling-water flow rate is 35 lb_m/sec, which provides a water velocity at the throat of 33 ft/sec with a water temperature rise during firing of approximately 5°F.

Engine ignition is provided by a hydrogen-air igniter assembly (Fig. 10). The hydrogen-air mixture is ignited by a spark plug and exhausted into the chamber through the center port of the injector. The total flow rate of the igniter reactants is approximately 0.11 lb_m/sec, and the air-to-fuel ratio is nominally 16.

2.2 INSTALLATION

The combustor, magnet, channel, and diffuser were installed in Propulsion Research Area (R-2C-4). A photograph and a schematic of the installation are shown in Fig. 11. The combustor was mounted on a support stand and connected to the facility propellant and coolant systems. The magnet was installed on the magnet support stand, with the channel on a support stand between the magnet pole faces. The forward flange of the channel was aligned with, and bolted to, the combustor nozzle flange. The channel diffuser extended through the forward bulkhead of a spray chamber that contains one air spray ring and four water spray rings. A 12-in. -diam exhaust duct was bolted to the downstream end of the spray chamber to direct the cooled exhaust gases into the facility exhaust ducting to be discharged into the atmosphere.

The spray chamber (Fig. 12) is a 36-in. -diam, 10-ft-long cylinder made of 1/4-in. mild steel. The air spray ring was located just forward of the diffuser exit plane (Fig. 11b) and provided a nonconducting shroud around the ionized exhaust gases to prevent electrical conduction to the spray chamber walls until the exhaust gases are cooled below the ionization temperature. The four water spray rings cooled the exhaust to a low

temperature before it entered the exhaust duct and was exhausted to the atmosphere. The spray chamber was insulated against 2000-v potential from ground, and the supply lines and drain line were made of cotton braid rubber hose. The resistance to ground through the lines was about 1000 ohms with the 6-in. drain line full of cooling water.

2.2.1 Electrical

An electric circuit used for the Hall channel is shown in Fig. 13. The electrical measurements made were: (1) voltage across the load resistors, (2) current from channel electrodes to the load bank, and (3) current from the channel element top-to-bottom.

The shunt panel (Fig. 14) is an electrical interface between the channel and the load bank, containing low resistance (0.0005-ohm) shunts, across which current between channel elements and between the channel and load bank is measured. Voltage taps and fuses to protect the meter circuits and load bank circuits were also provided in the shunt panel.

2.2.2 Propellant System

A schematic of the propellant system is shown in Fig. 15. The GO_2 was supplied from a 55,000-scf trailer charged at pressures ranging to 800 psia. The pressure was reduced and maintained at a value to provide the desired flow rate by an automatic pressure control system.

The RP-1 flow was supplied by, and controlled from, a 75-gal stainless steel tank pressurized with dry nitrogen. The pressure-fed alcohol-KOH seeding agent was injected into the RP-1 line upstream of the engine injector. All propellant systems incorporated provisions for purging the lines with dry nitrogen.

2.3 INSTRUMENTATION

Instrumentation was divided into two distinct groups - engine and spray chamber instrumentation (herein designated support equipment instrumentation) and channel and magnet instrumentation. Instrument ranges, recording methods, and system accuracies for all measured parameters are presented in Table I (Appendix II).

2.3.1 Support Equipment Instrumentation

Instrumentation was provided to measure combustor chamber pressure, injector pressures, propellant and seed flow rates, propellant

tank pressures, combustion chamber and nozzle cooling water temperature rise, and spray chamber pressure.

Bonded strain-gage-type transducers were used to measure pressures. Copper-constantan thermocouple probes were used to measure cooling-water inlet and discharge temperatures, and iron-constantan probes were used to measure propellant temperatures. Fuel and seed flow rates were measured with turbine-type flowmeters. The GO_2 flow rate was determined by a critical flow venturi located downstream of the pressure control system.

The output signal of each measuring device was recorded on independent instrumentation channels. Primary combustor data were obtained from two combustion chamber pressure channels (one 50- and one 100-psia), one oxygen venturi upstream pressure channel, two injector pressure channels (oxidizer and fuel), two fuel flow channels, and two seed flow channels. The primary data were recorded as follows: Each pressure output signal was transmitted to a millivolt-to-frequency converter. A magnetic tape system, recording the frequency form, stored the signal from the converter for reduction at a later time by an electronic digital computer. The computer provided a tabulation of average absolute values for each 0.2-sec time increment. The fuel and seed flow signals were transmitted through wave shaping converters to the magnetic tape systems. A photographically recording, galvanometer-type oscillograph recording at a paper speed of 10 in./sec provided an independent backup of all primary instrumentation channels. The secondary data were recorded on magnetic tape from a multi-input, high-speed, analog-to-digital converter at a scan rate for each channel of 75 times/sec. Playback of these tapes on the IBM 360 and Raytheon 520 computers provided a tabulation of average absolute values for each 0.2-sec time increment.

2.3.2 Channel and Magnet Instrumentation

Generated voltages and currents and magnet input voltage and current were displayed on an array of meters located on a rack-mounted meter panel (Fig. 16) and insulated for 2000-v potential to ground. The data from these meters were recorded photographically by a 70-mm camera that was timer actuated to provide photographs at approximately 1-sec intervals during a power generation firing. These photographs were time correlated with engine burn time by "camera pulses" recorded on the oscillograph.

SECTION III PROCEDURE

The assembled Hall channel was received at AEDC on February 7, 1967. The channel was installed, and power generating runs were made for a variety of electrical loads.

The sequence of events for each firing was accomplished automatically by use of electric timers and relays. For a typical firing, the sequence is as follows:

- t_0 Fire button actuated manually
- $t_0 + 1$ Igniter air valve open; spark plug begins to fire
- $t_0 + 1.5$ Igniter hydrogen valve open
- $t_0 + 4$ Propellant valves electrically energized
- $t_0 + 5$ Engine ignition; igniter spark plug and propellant valves de-energized
- $t_0 + 5.5$ Seed reaches chamber; power generation commences
- $t_0 + 12$ Seed valve de-energized
- $t_0 + 14$ Propellant valves de-energized; nitrogen purge through propellant lines initiated.

The purges were directed through the engine, channel, diffuser, and the facility exhaust and, in addition to clearing the propellant lines, helped to cool the channel for the following firing. The purge was continued until the firing panel was reset.

SECTION IV RESULTS AND DISCUSSION

A Hall MHD electric power generator channel was tested to determine the effect on generator performance of variations in external resistance loading. The products of combustion from a $\text{GO}_2/\text{RP-1}$ combustor seeded with a saturated solution of potassium hydroxide in ethyl alcohol were supplied to the generator inlet at a Mach number of 1.6 and at a nominal total pressure of 46 psia.

The measured values of combustor chamber pressure and propellant flow rates, generator resistance loading, and generated electric currents and voltages are presented in this report. The conditions at which performance data were obtained are summarized in Table II. Data from 59 firings are included. Also presented are the combustor operating characteristics and the results of high-speed electrode photography.

4.1 COMBUSTOR OPERATING CHARACTERISTICS

The analog values of chamber pressure, propellant flow rates, and injector pressures during a typical engine ignition are shown in Fig. 17. Also shown is the camera pulse trace that relates the time when generator electrical data were photographically recorded with combustor operational events. The times required for the RP-1 and the seed to reach the chamber after propellant valve actuation were 0.7 and 1.5 sec, respectively, at the nominal combustor operating condition. The seed flow lag time (1.5 sec) was intentionally long to prevent admittance of seed into the MHD channel prior to increase of channel wall temperature, thereby preventing electrically conducting seed residue from condensing on the cold walls of the channel.

Chamber pressure and RP-1, oxygen, and seed flow rates are presented in Fig. 18 for a typical firing. Seed flow was stopped approximately 2 sec prior to engine shutdown to ensure removal of all seed residue from the channel walls.

The average values of chamber pressure and oxygen, RP-1, and seed flow rate during the 1-sec period prior to seed flow shutoff (Δt_2 in Fig. 18) are presented in Table III. Time t_1 in Fig. 18 and in Table III represents the time from activation of the firing circuit to the initiation of chamber pressure increase. Since the time base for all data tabulated in this report is referenced from firing circuit energization, t_1 can be used for correlating events from combustor ignition.

The combustor operated at a nominal chamber pressure of 46 psia, total propellant flow rate of 1.75 lb/sec, and an oxygen-to-fuel ratio of 2.8. Characteristic velocity was nominally 5200 ft/sec based on chamber pressure at the injector face. The combustion efficiency, based on the theoretical performance of kerosene and oxygen propellants (Ref. 4), is estimated to be 93 percent, which provided a combustion chamber gas temperature of approximately 5000°F.

4.2 GENERATOR PERFORMANCE DATA

The measured values of individual channel resistance loads are presented in Table IV. Power was primarily extracted through one large center resistor (R_C). Generated power as a function of load resistance is presented in Fig. 19.

Typical channel electric currents and voltages measured during the 1-sec period prior to seed flow shutoff are presented in Table V. Channel total current, total voltage, and combustor chamber pressure values during a typical generating run are shown in Fig. 20. Sign conventions used were: (1) current from channel-to-load bank denoted positive, (2) current from top of channel element to bottom of channel element denoted positive, and (3) increasing electrical potential above upstream channel potential denoted positive.

4.3 HIGH-SPEED ELECTRODE PHOTOGRAPHY

An objective of this experiment was to obtain photographic documentation of electric arcing between the plasma and the electrode surface. Electrode 51 of the Hall channel was constructed to permit photographic access to the bottom electrode surface through a 1.5-in.-diam, 12-in.-long tube (equipped with a 0.25-in.-thick quartz window) mounted on the channel top (Fig. 1). A cooling-water passage was provided internal to the downstream edge of the photographic access port to prevent excessive heating and erosion in this area from the impingement of the hot plasma. Raw water was continuously supplied during the firing through a nonconducting line at a nominal pressure of 100 psia. A 16-mm motion-picture camera, installed as shown in Fig. 21, was utilized.

Various camera speeds, film exposures, and optical filters were utilized while successfully photographing electrode arcing on the cathode surface (with the magnet polarity reversed). A series of photographs showing an arc "spot" crossing the cathode surface is shown in Fig. 22. The photographic setup used in obtaining these test results was as follows: camera speed, 5500 frames/sec; optical setting, $f/5.6$; one neutral density filter; and three No. 57 Wratten filters.

No electrode arcing was observed on the anode surface (with the magnet polarity normal).

4.4 CHANNEL STRUCTURAL DURABILITY

The determining factor governing the number of test firings accomplished was the channel electrical insulation durability. No pitting or metal erosion in the internal flow passage was observed.

Testing was discontinued after 71 firings with a total burn duration of 532 sec because intense arcing was observed between the downstream channel transition element and the channel support stand. Post-fire inspection also revealed partial blowout of the mica paper insulation from between some channel segments. Post-fire photographs of the Hall channel are shown in Fig. 23.

REFERENCES

1. LeBoeuf, R. J. and Nelius, M. A. "Experimental Performance of Two Segmented Wall Magnetohydrodynamic Electric Power Generators." AEDC-TR-66-240 (AD805710), January 1967.
2. LeBoeuf, R. J. and McNeese, J. D. "Experimental Performance of a 60-deg-slant Segmented Wall Magnetohydrodynamic Electric Power Generator." AEDC-TR-67-174, October 1967.
3. Dicks, John B., Jr., Wu, Ying-chu Lin, Witkowski, Siegbert, Shanklin, Richard, III, Zitzow, Uwe, Chang, Pat and Ziemer, Roger. "Diagonal Conducting Wall Generators." AFAPL-TR-67-25, January 1967.
4. Huff, V. N. and Fortini, A. "Theoretical Performance of JP-4 Fuel and Liquid Oxygen as a Rocket Propellant." NACA RME56A27, April 1956.

APPENDIXES
I. ILLUSTRATIONS
II. TABLES

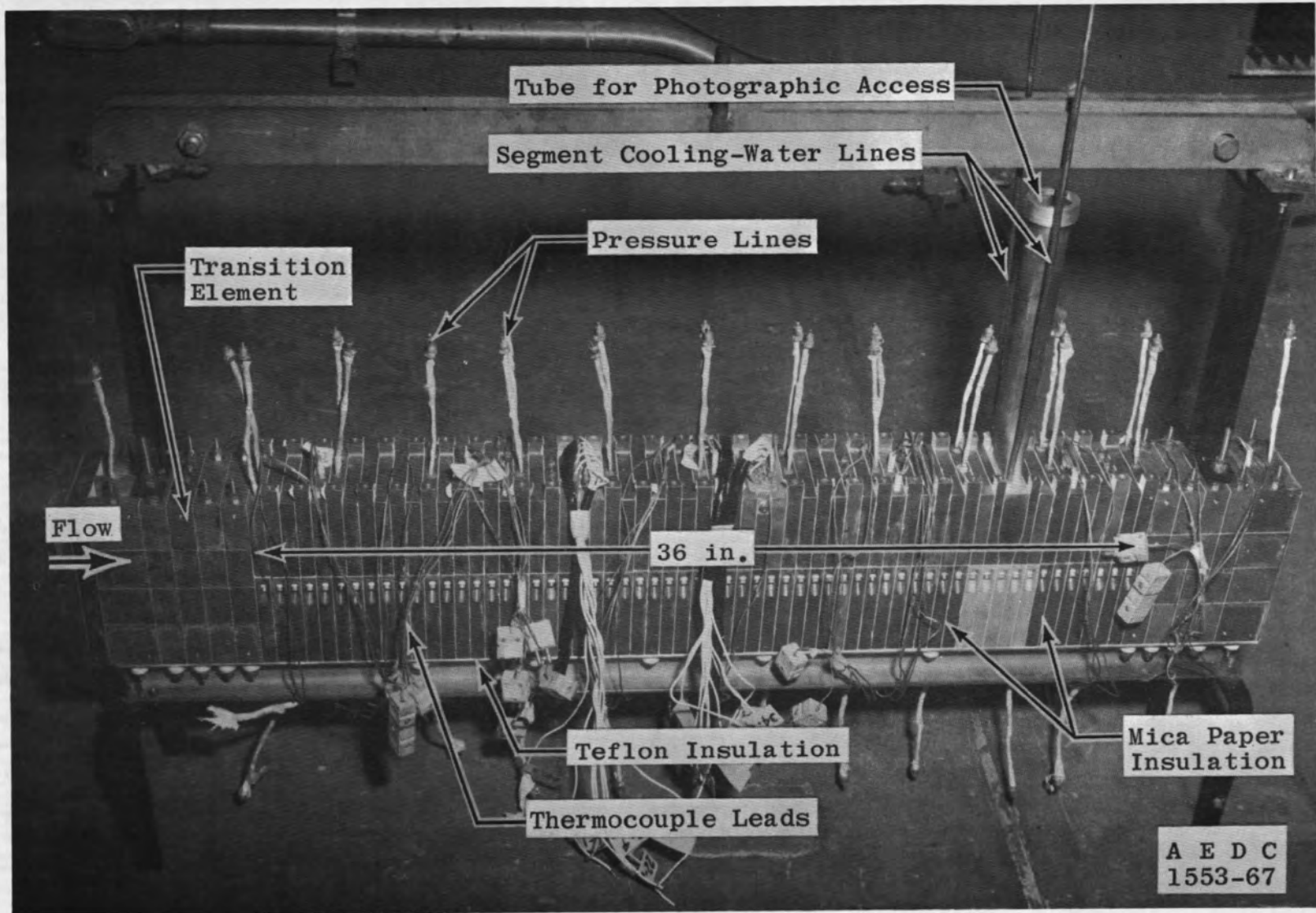

Fig. 1 Pre-fire Photograph of Hall Channel

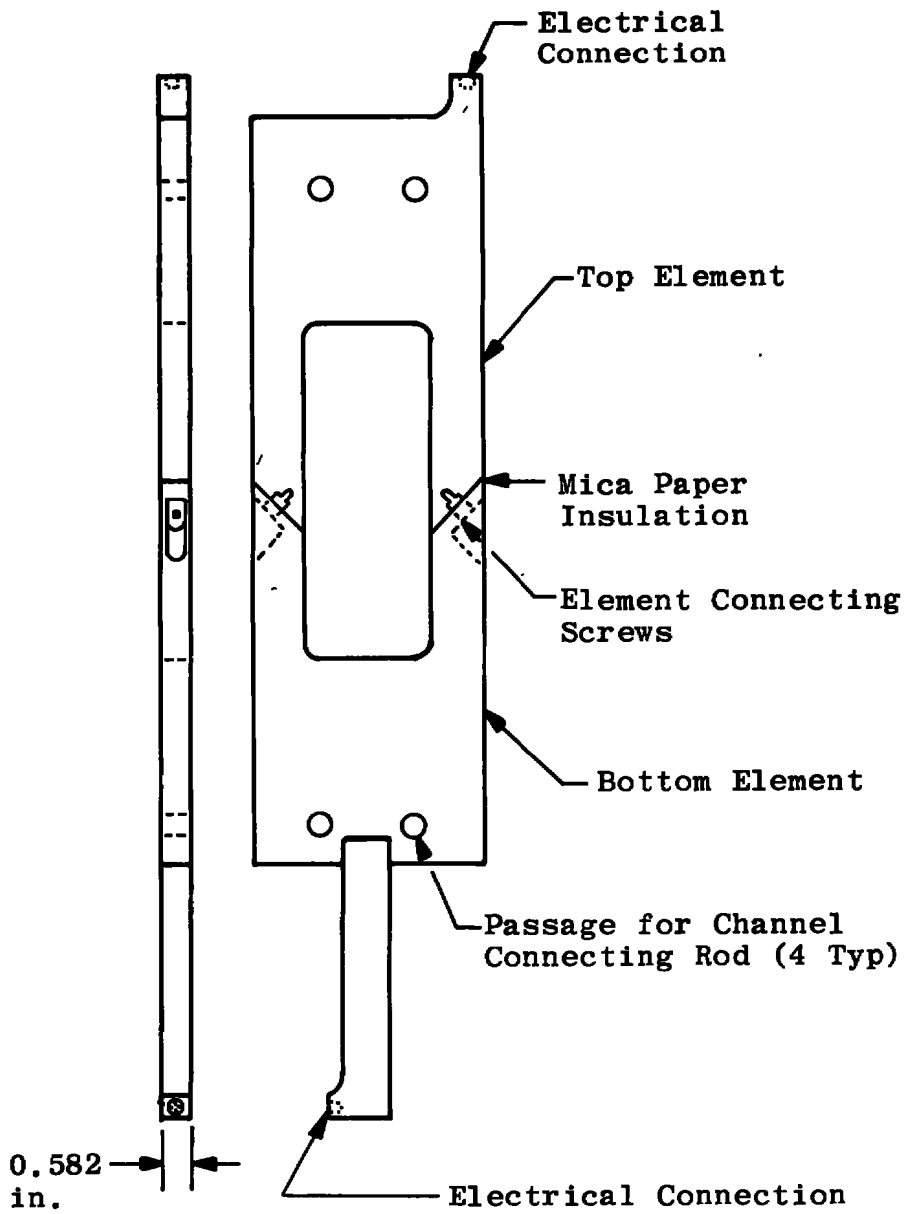
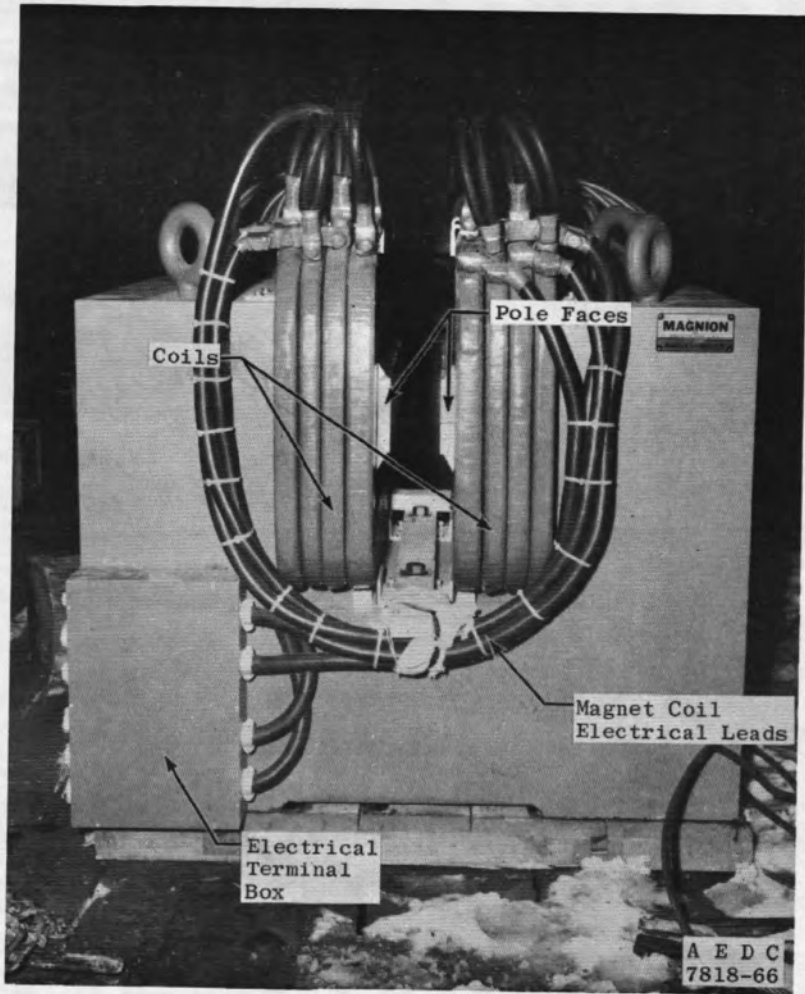
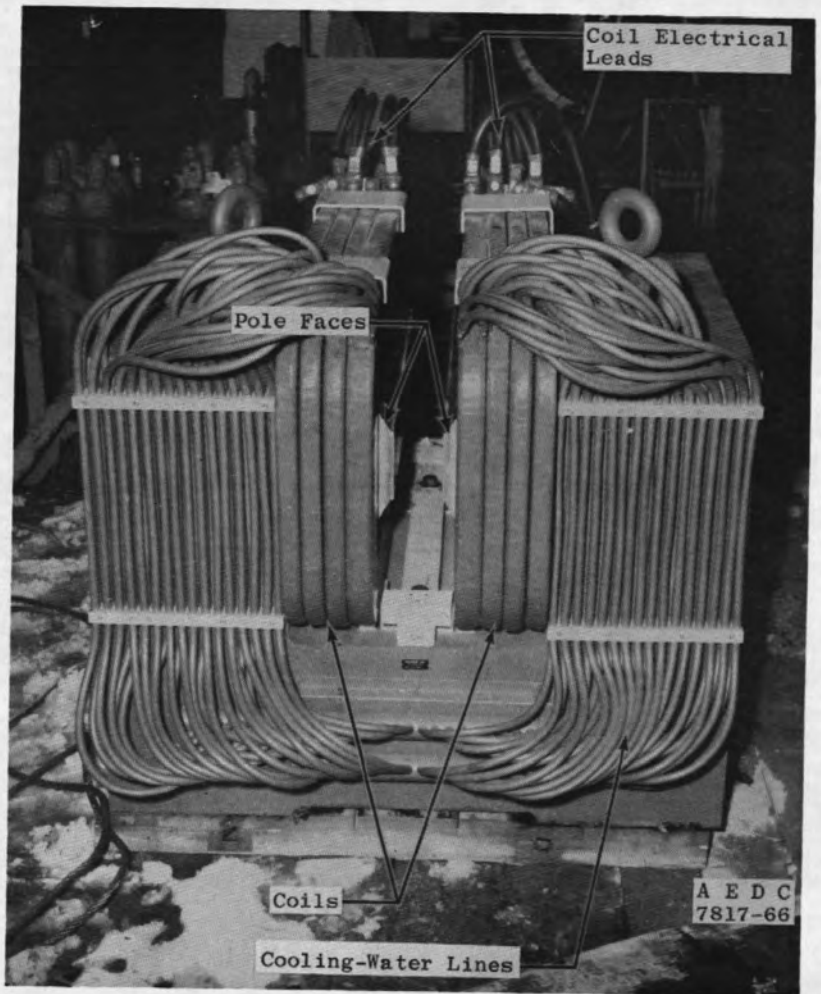

Fig. 2 Schematic of Hall Channel Segment



a. Photograph, Looking Upstream



b. Photograph, Looking Downstream

Fig. 3 Electromagnet

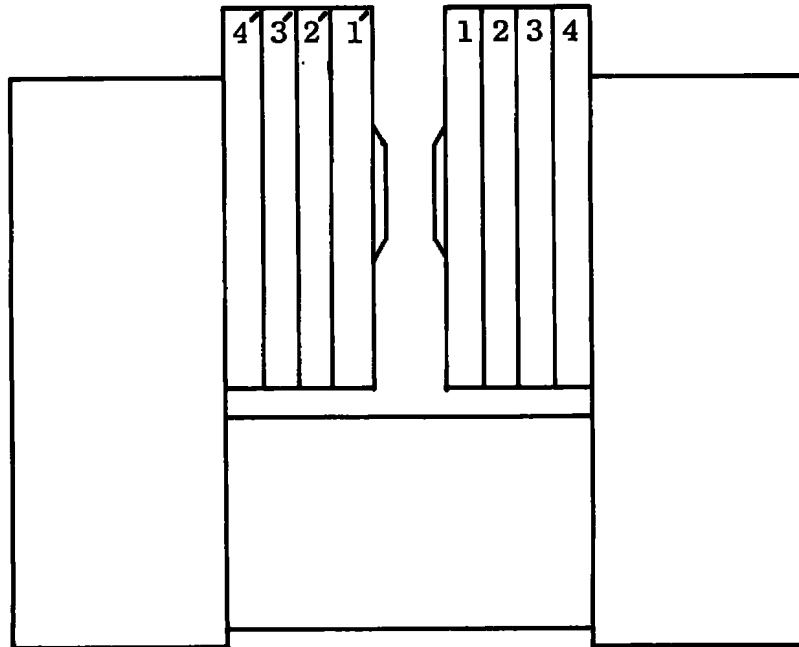

Coil Locations
(Looking Upstream)

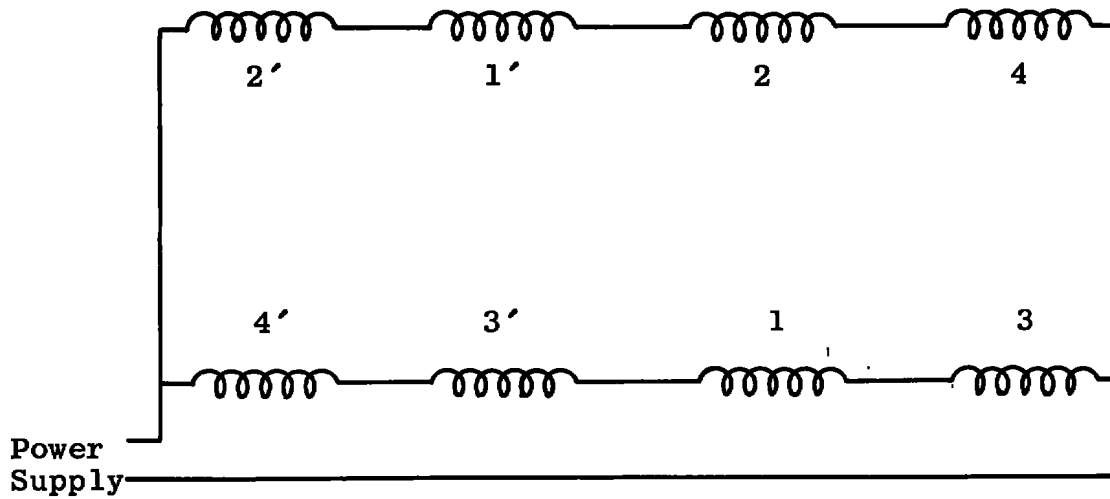

c. Coil Electrical Schematic

Fig. 3 Concluded

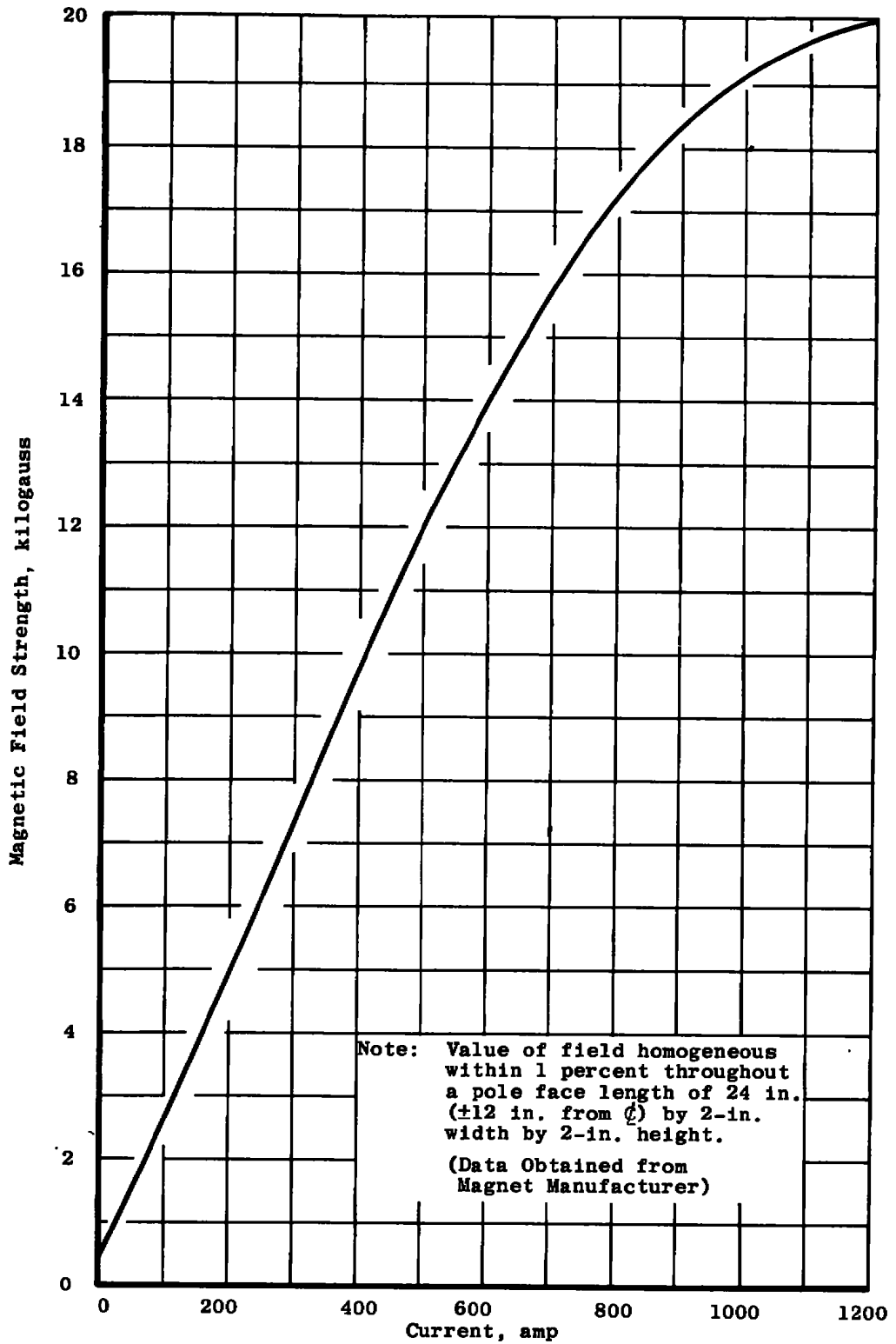

Fig. 4 Magnet Field Strength as a Function of Current

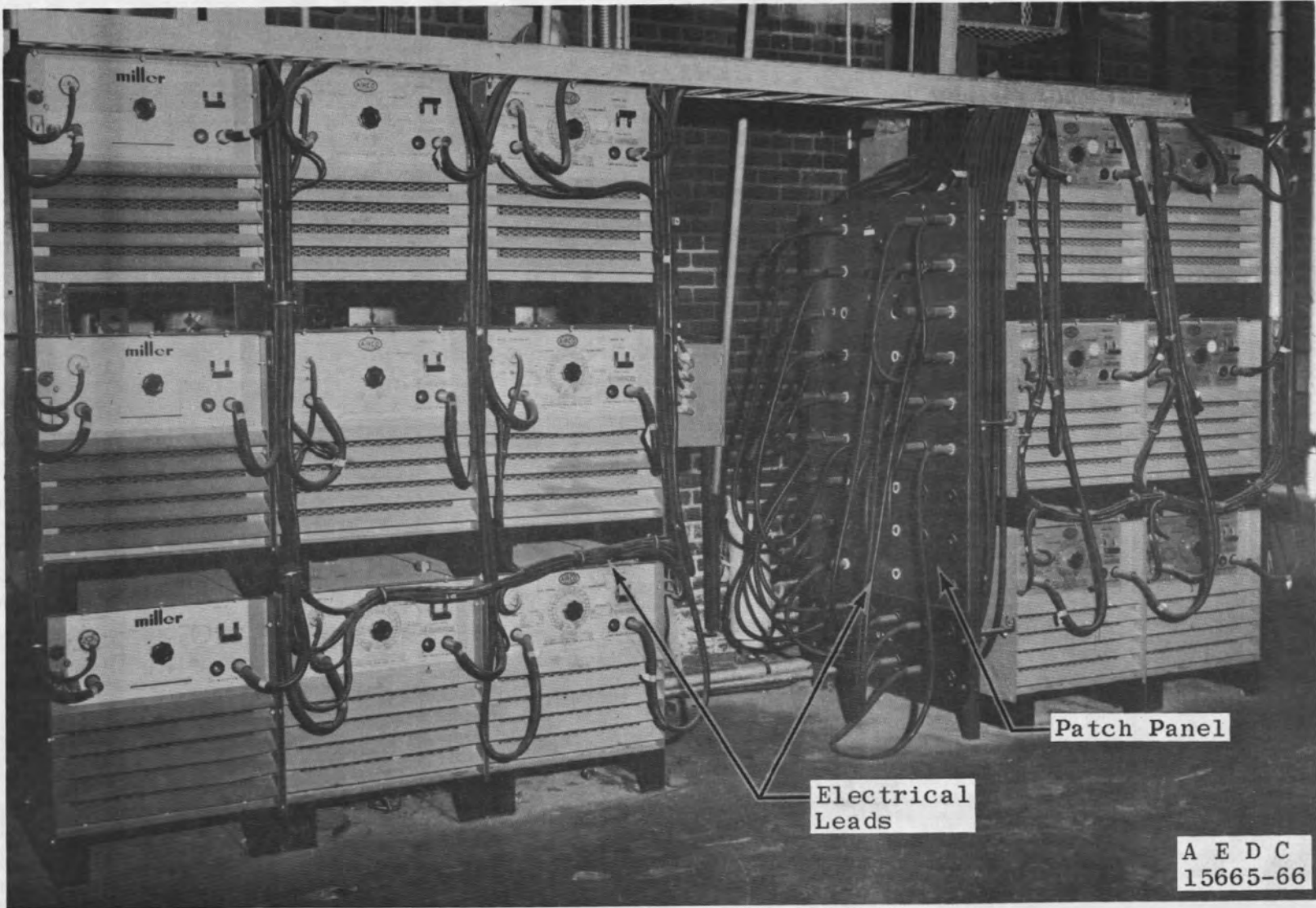
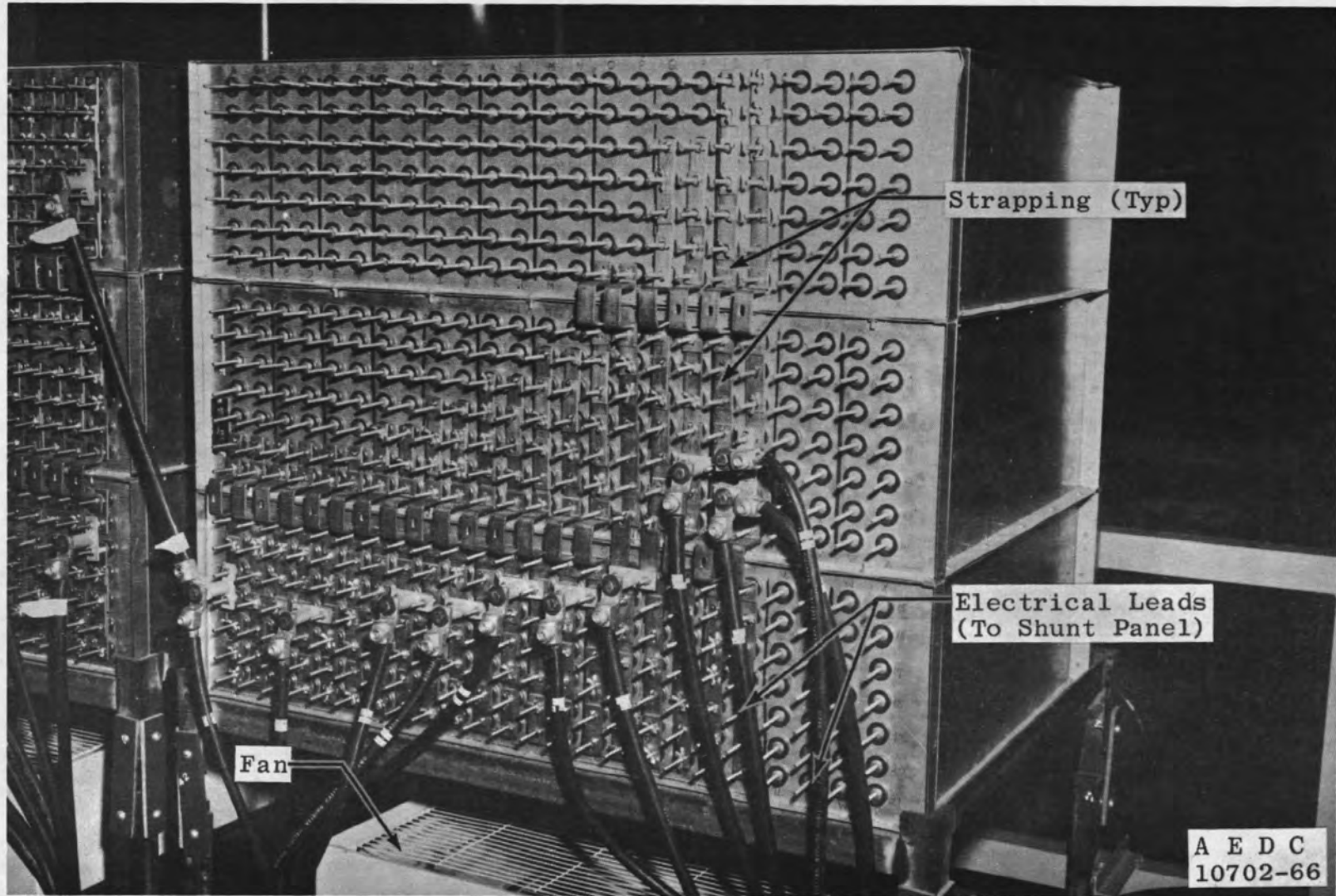
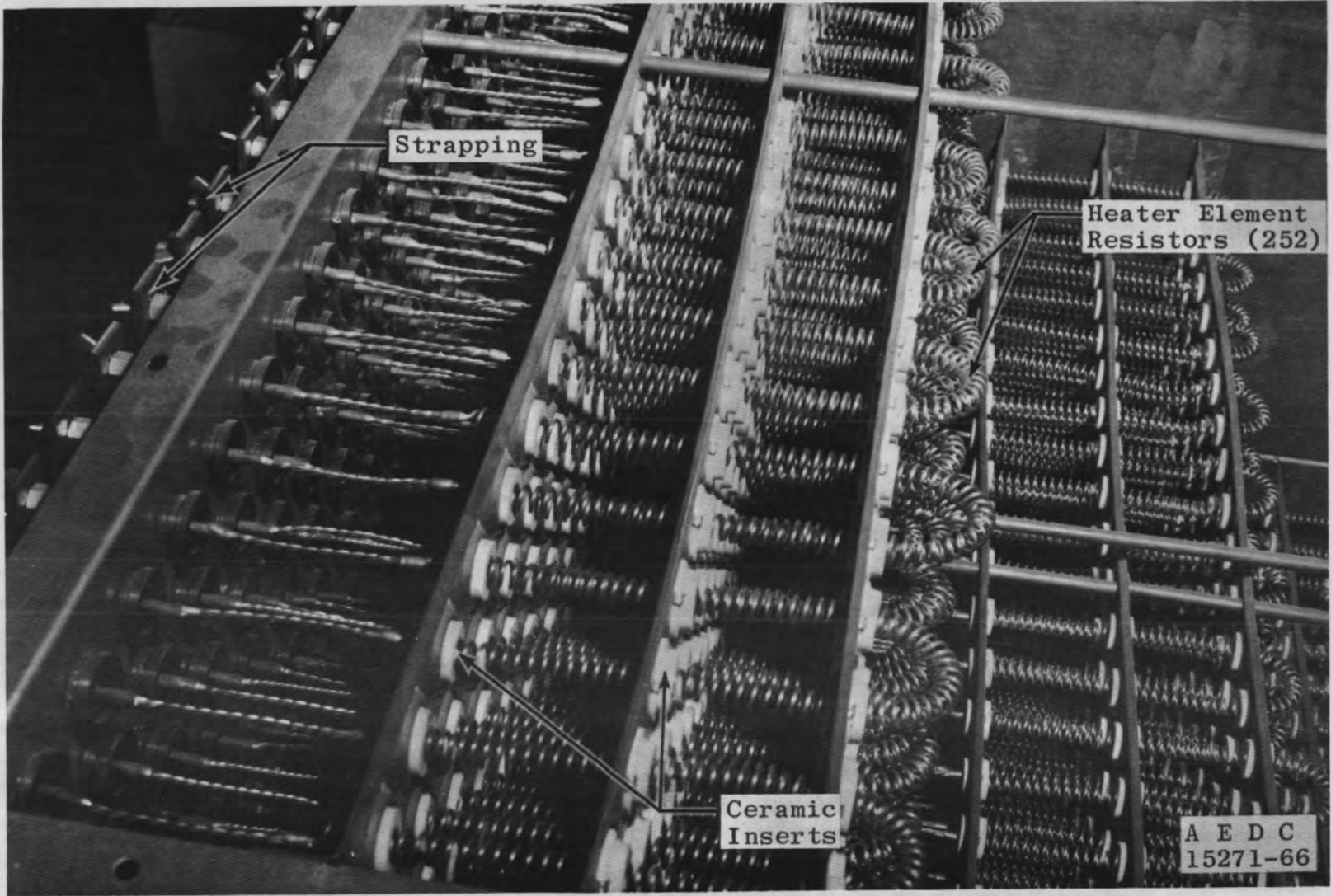

Fig. 5 Photograph of Magnet Power Supplies



a. Front View

Fig. 6 Photographs of Load Bank Unit



b. Top View
Fig. 6 Concluded

A E D C
15271-66

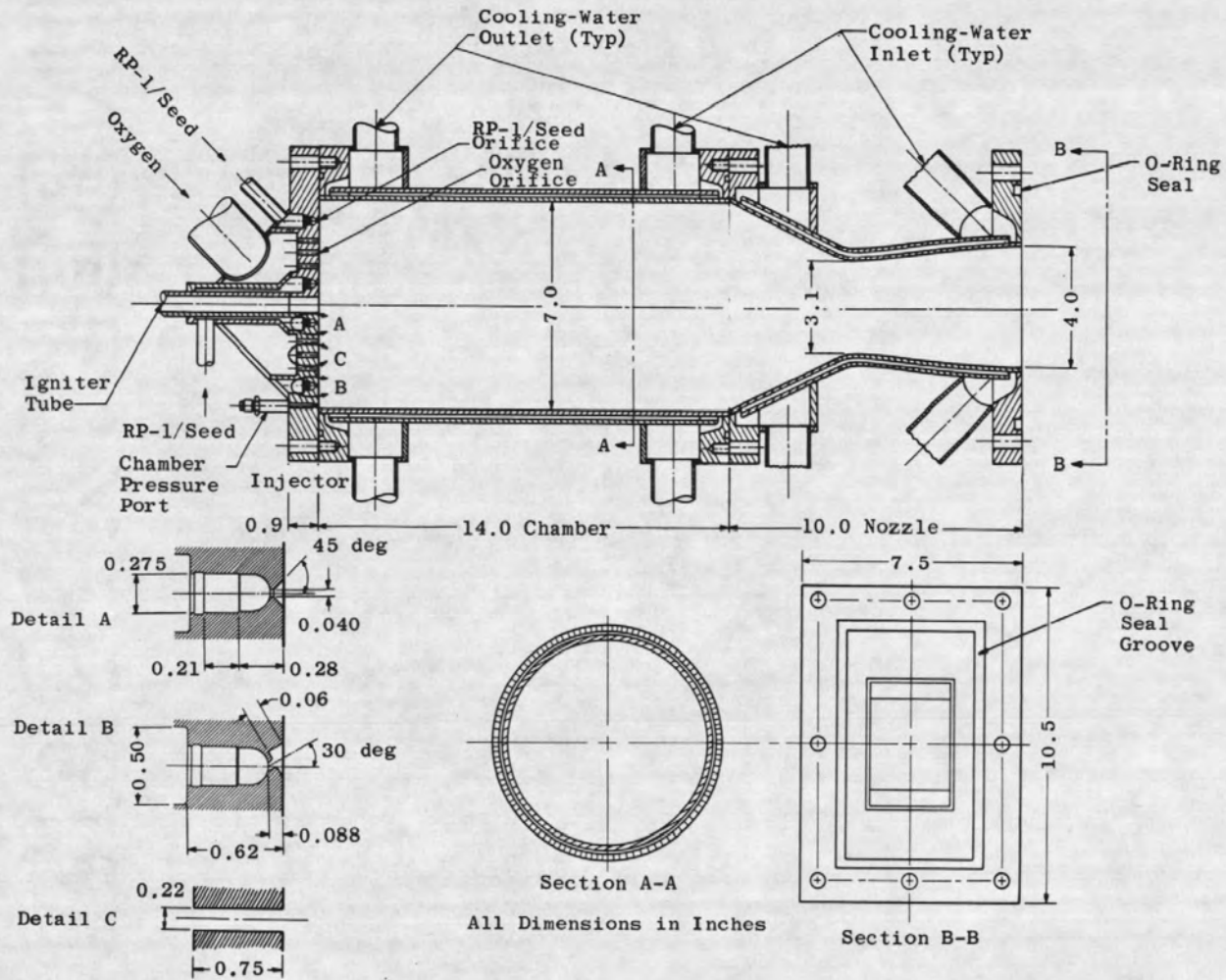

Fig. 7 Schematic of Combustor

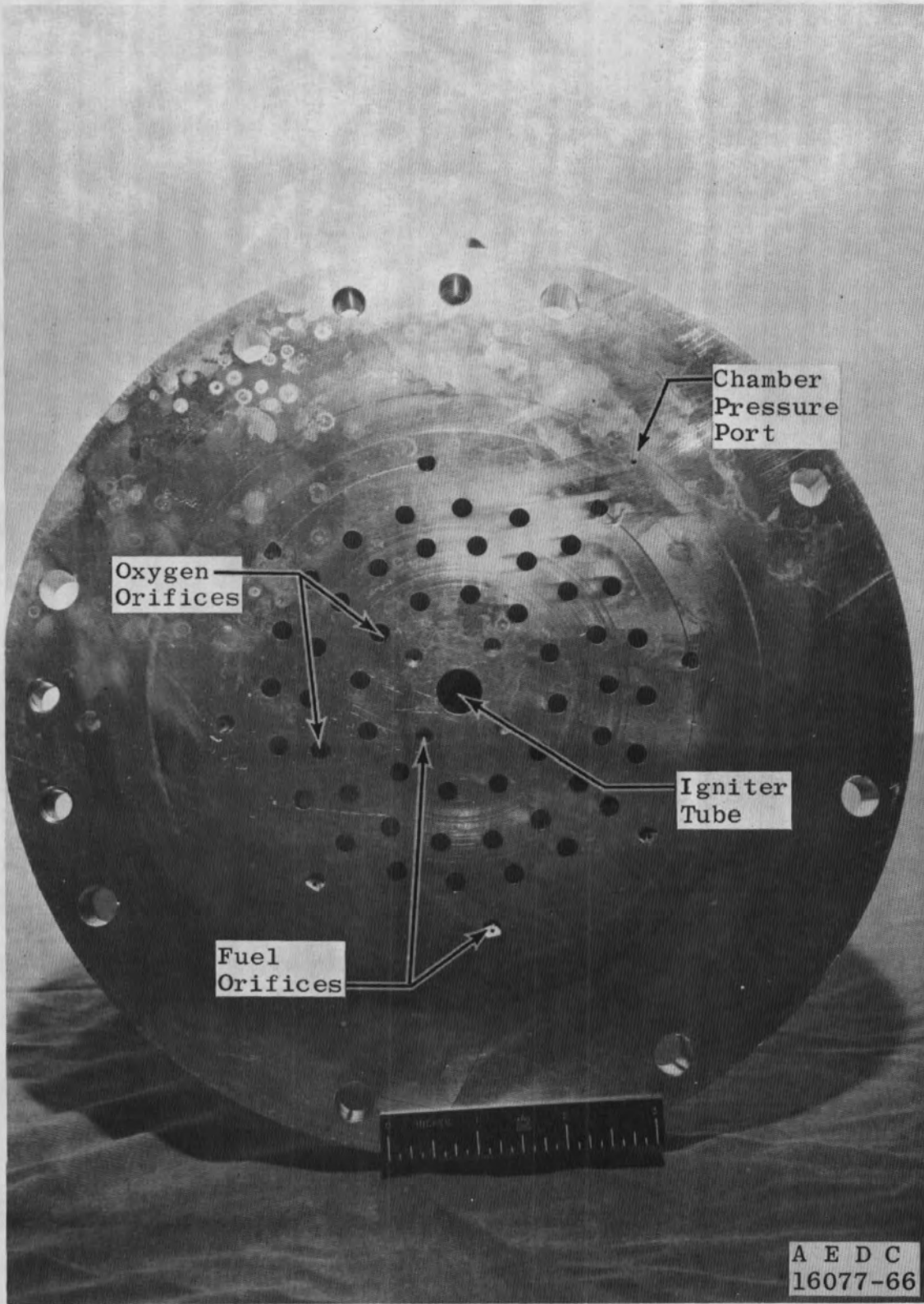
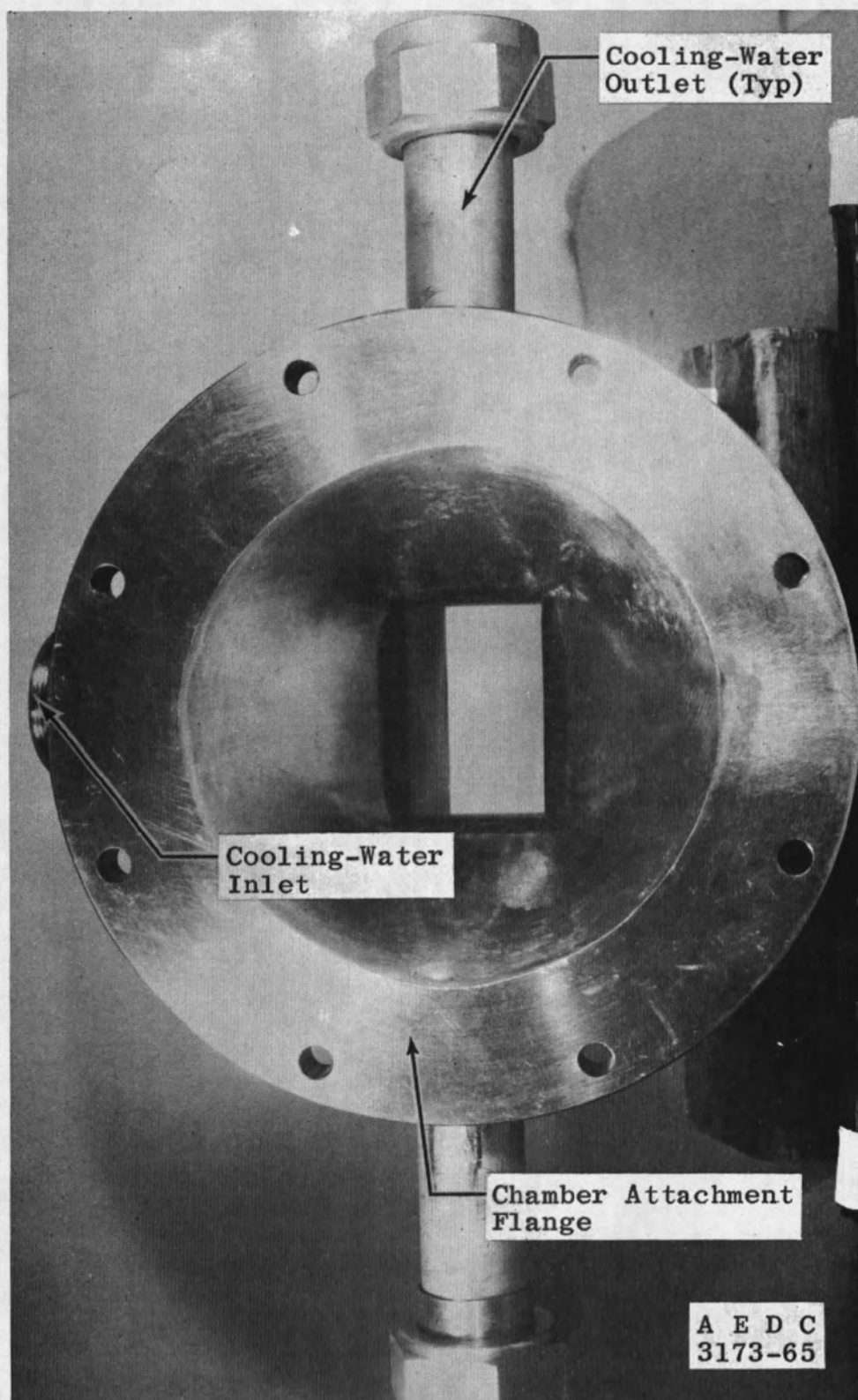
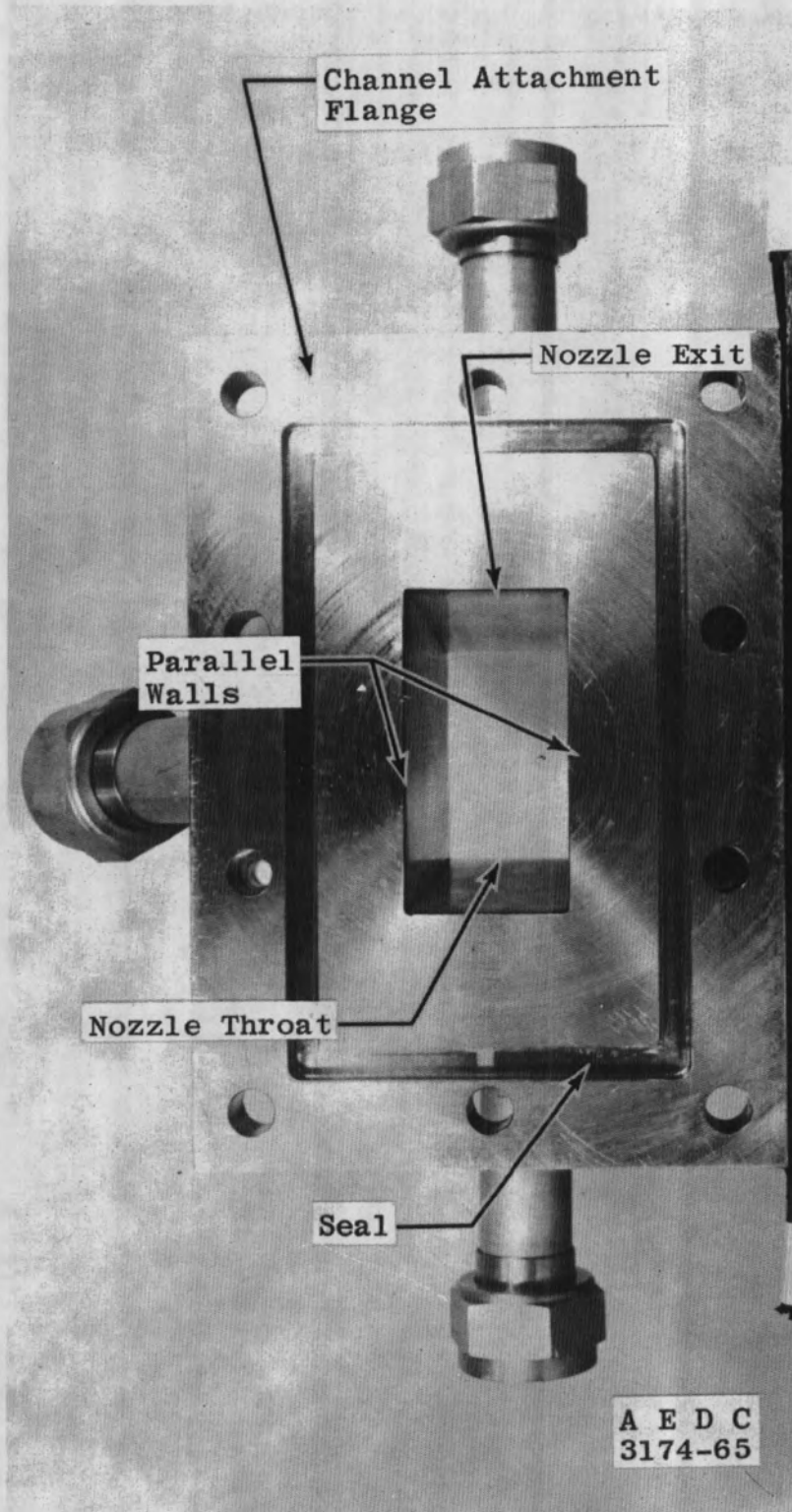

Fig. 8 Photograph of Injector



a. Looking Downstream

Fig. 9 Photographs of Water-Cooled Exhaust Nozzle Assembly



b. Looking Upstream

Fig. 9 Concluded

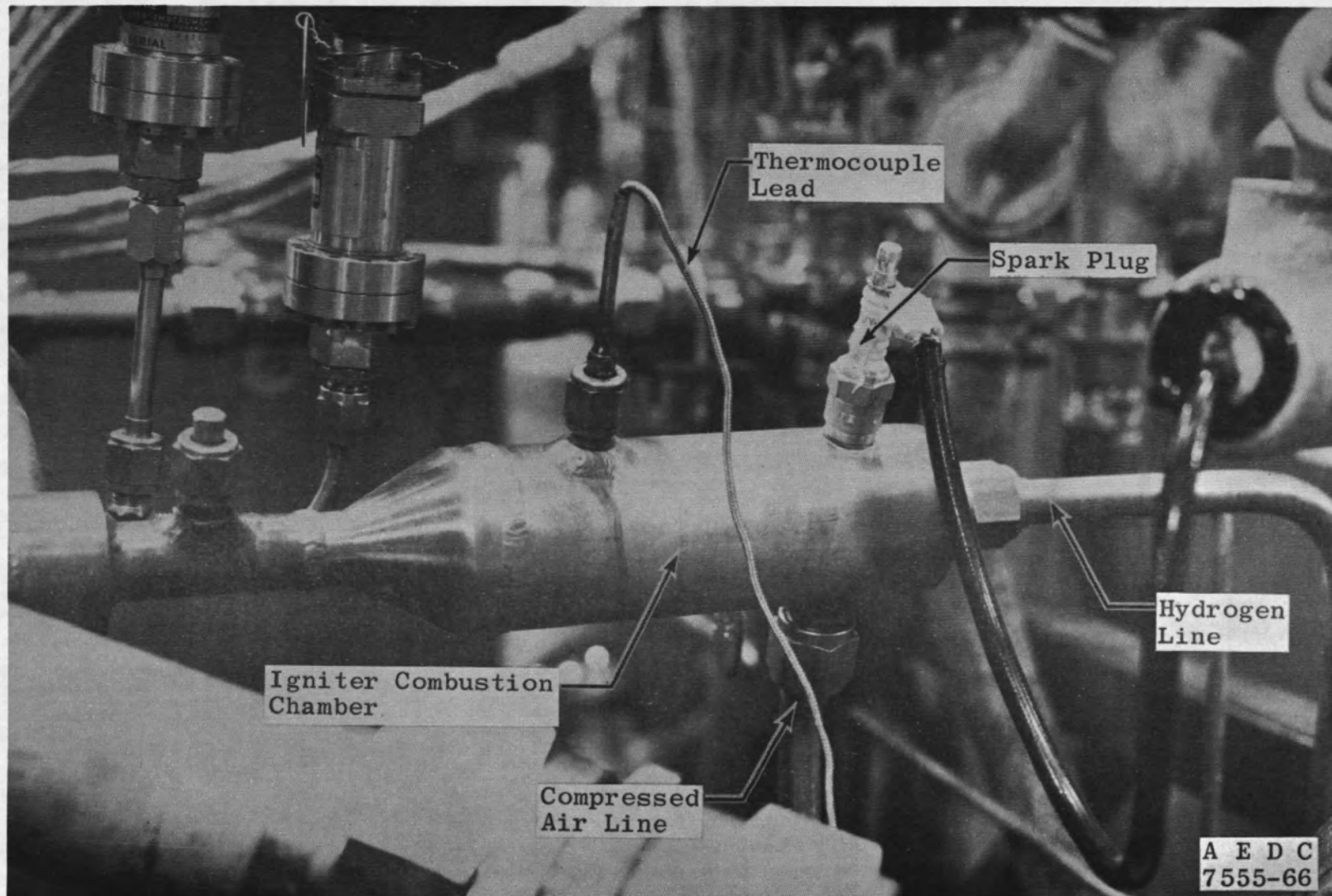

a. Photograph

Fig. 10 Igniter Assembly

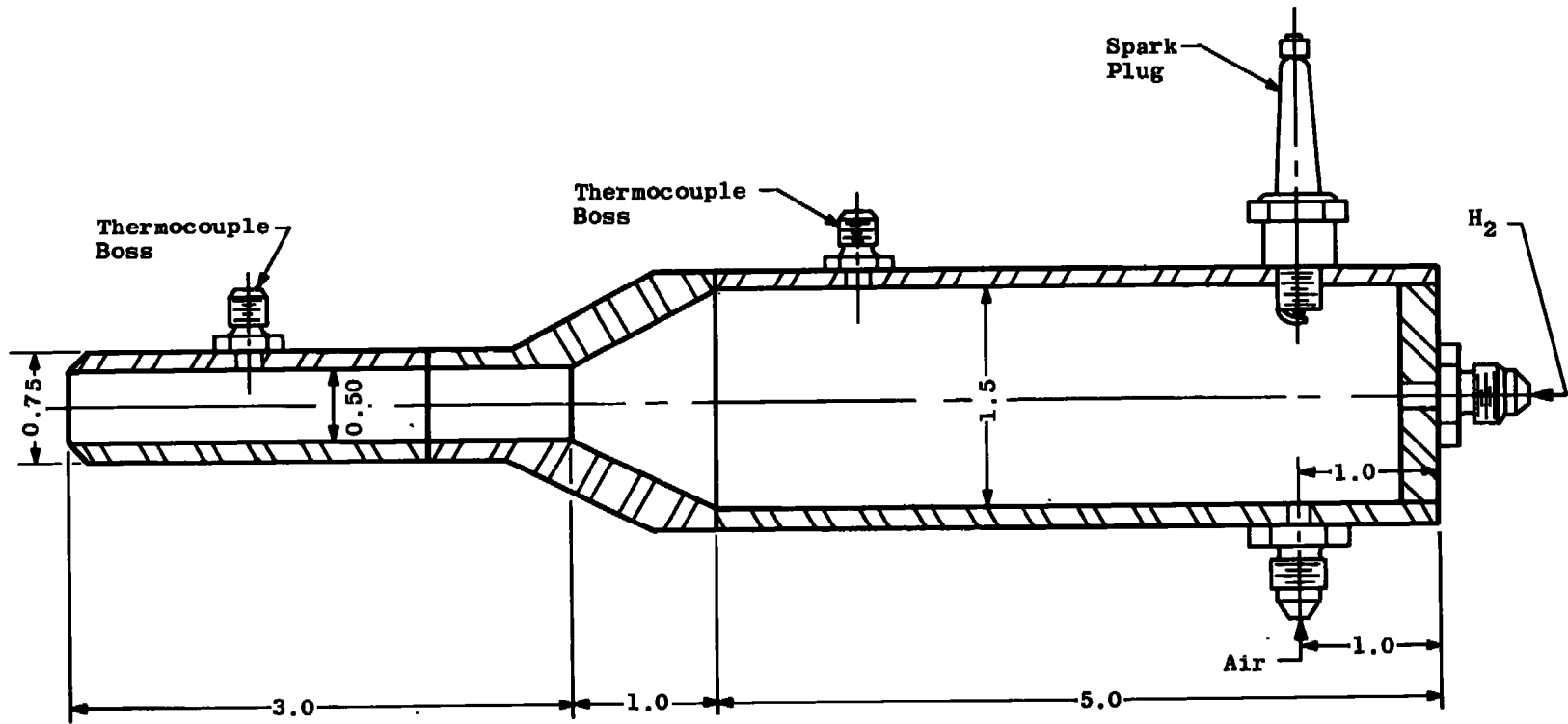

28

All Dimensions in Inches

b. Schematic
Fig. 10 Concluded

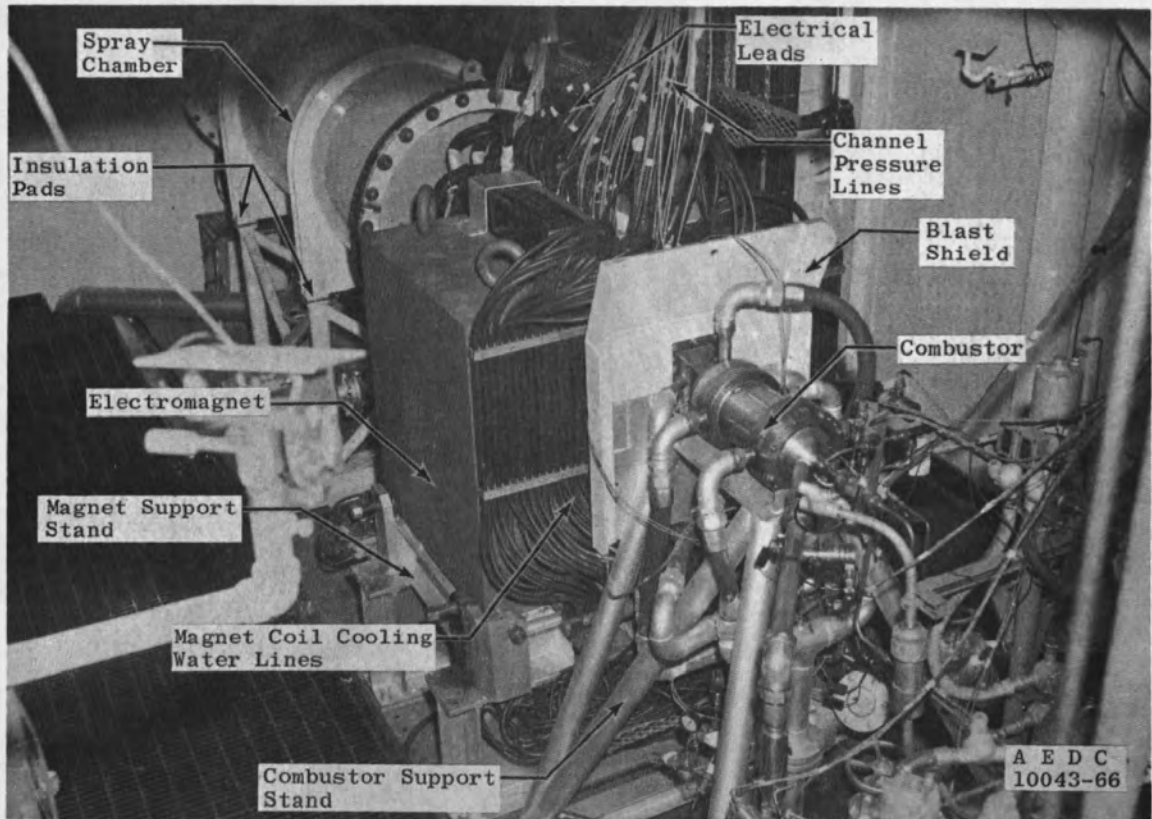

a. Photograph

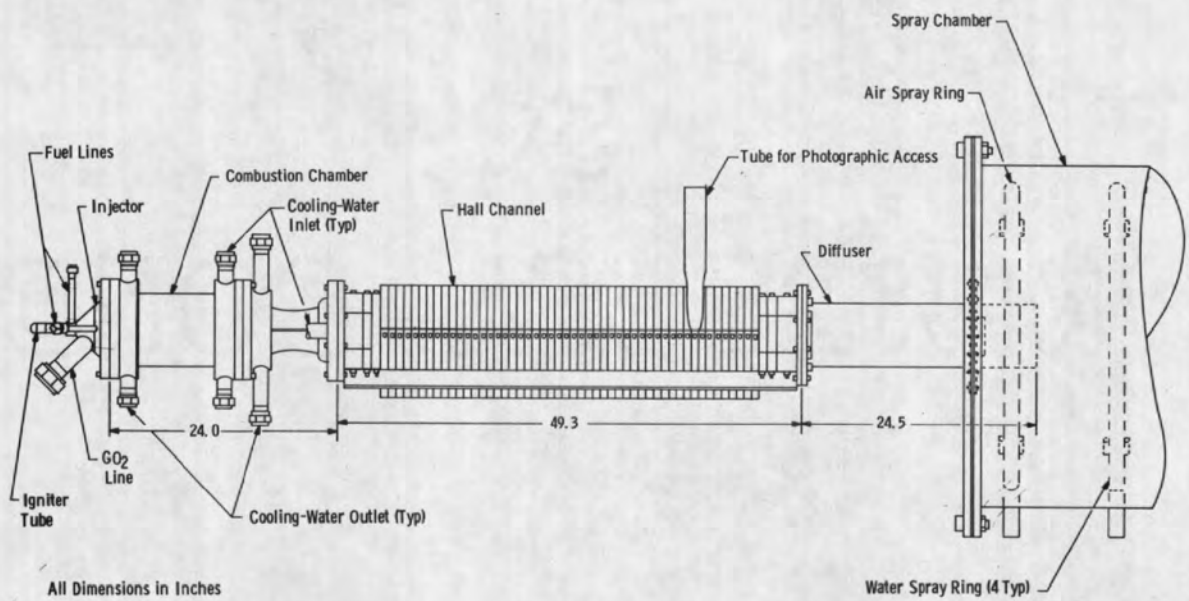

b. Schematic

Fig. 11 Installation of MHD Generator Assembly in Propulsion Research Area (R-2C-4)

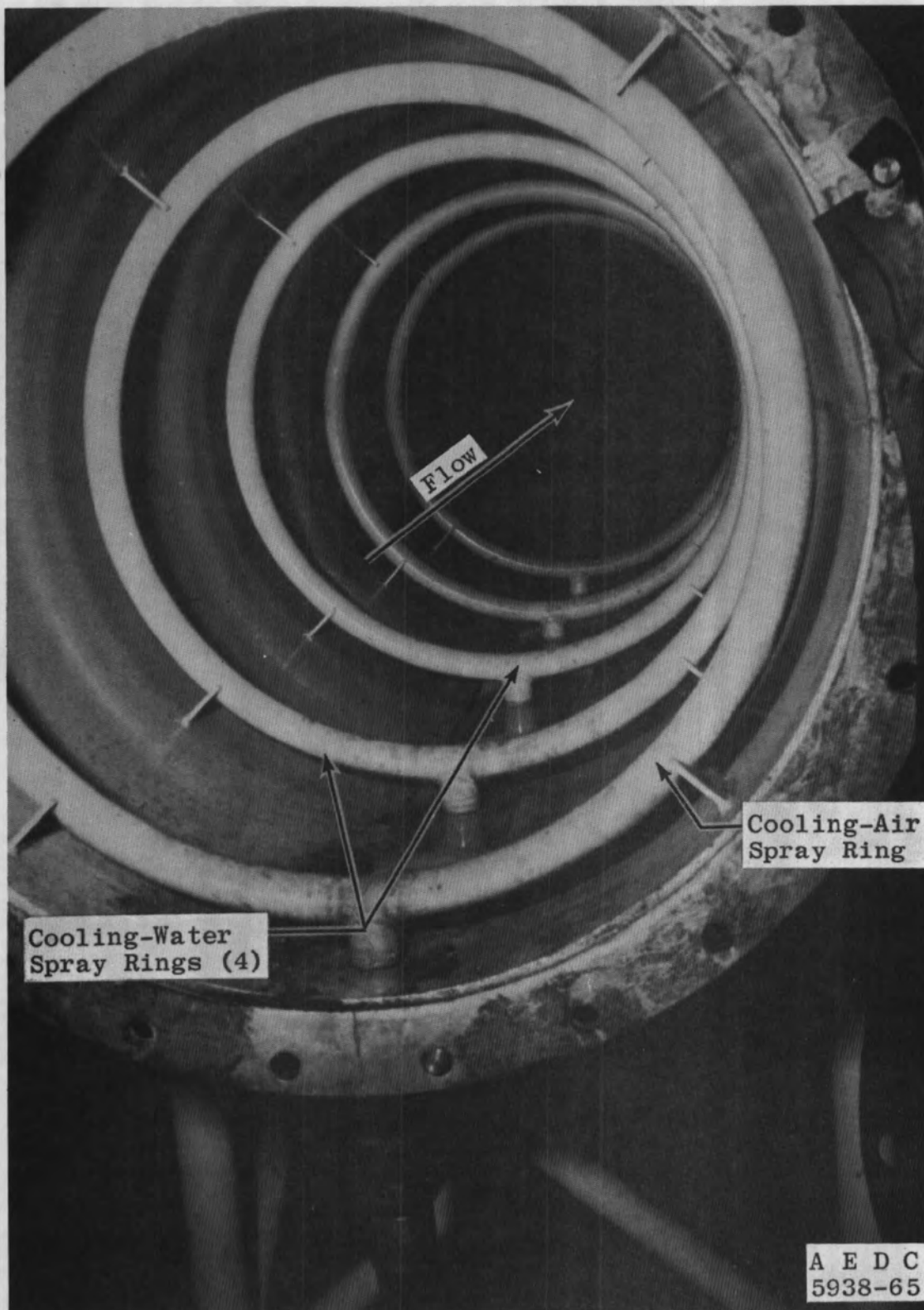
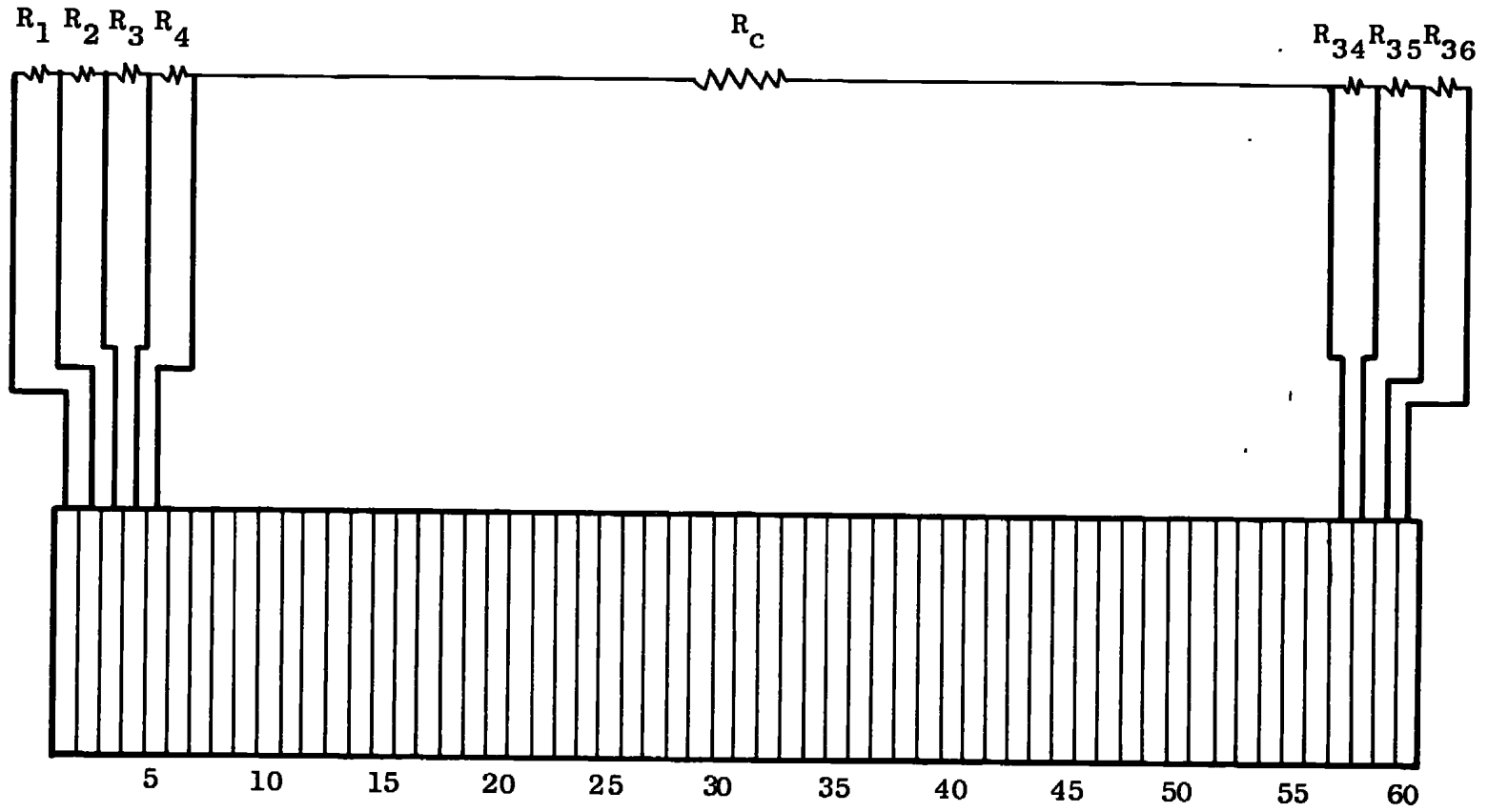
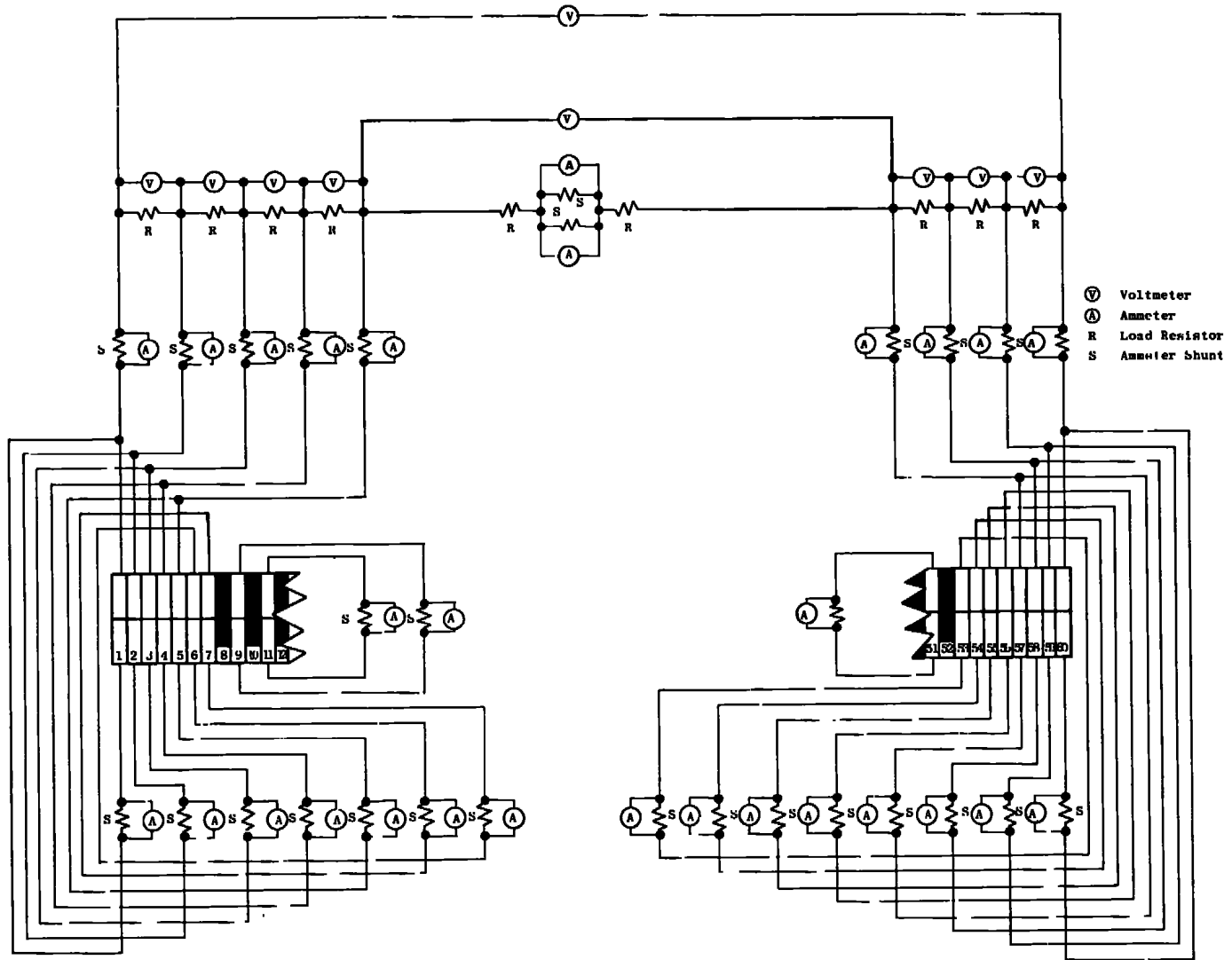

Fig. 12 Photograph of Spray Chamber



a. Without Instrumentation

Fig. 13 Schematics of Hall Channel Electrical Circuit



b. With Instrumentation

Fig. 13 Concluded

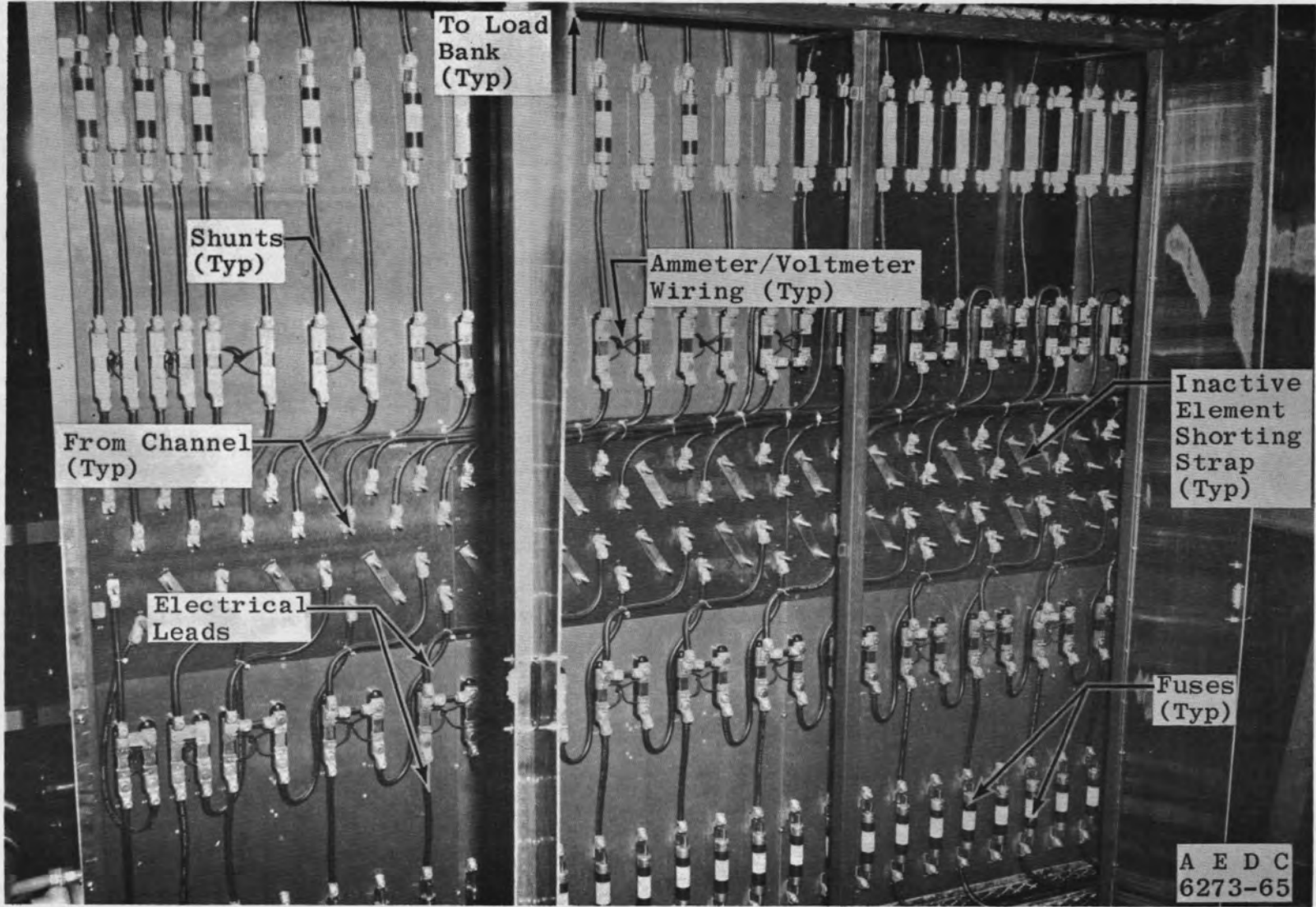

Fig. 14 Photograph of Shunt Panel

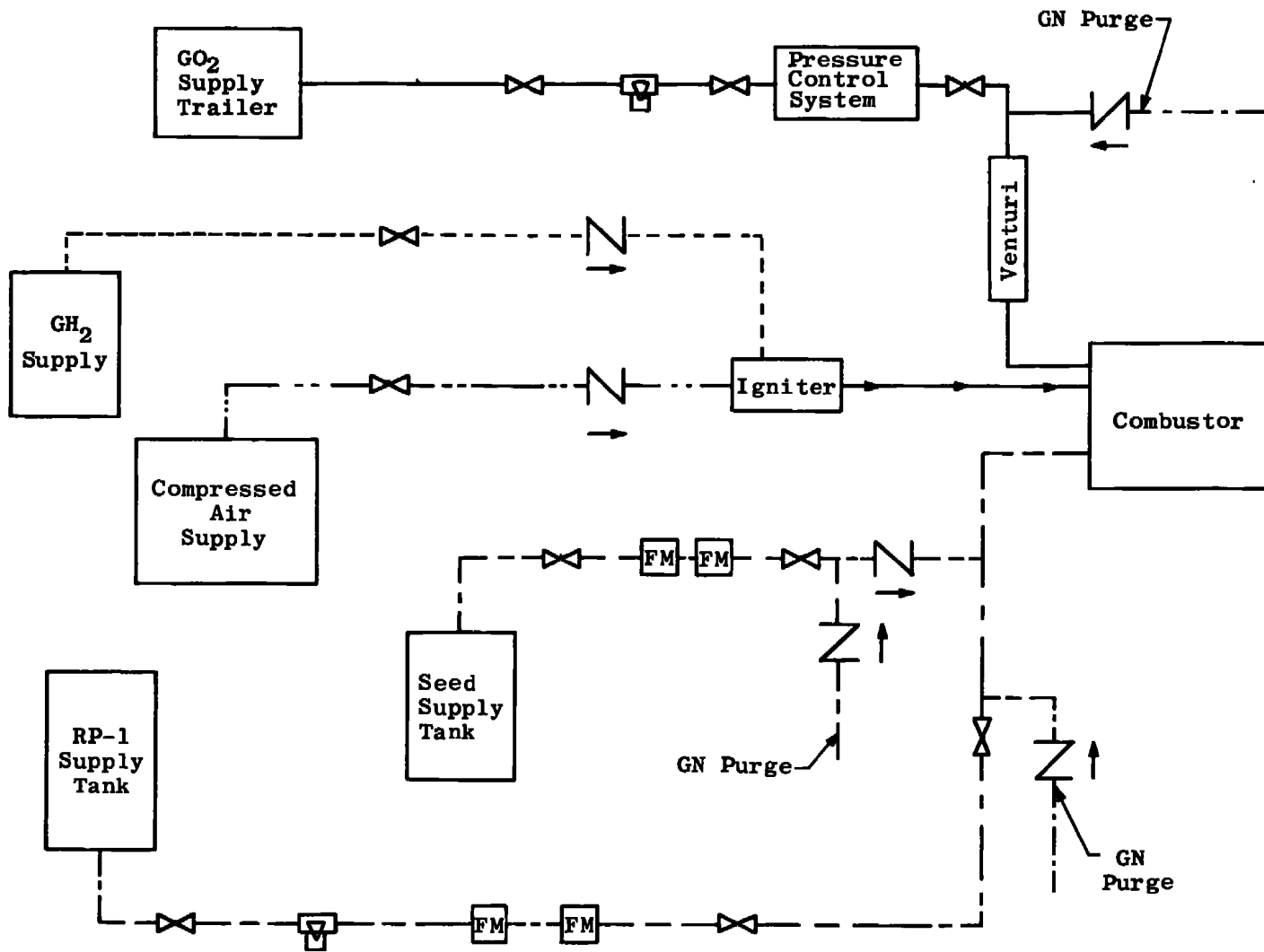

Fig. 15 Schematic of Propellant System

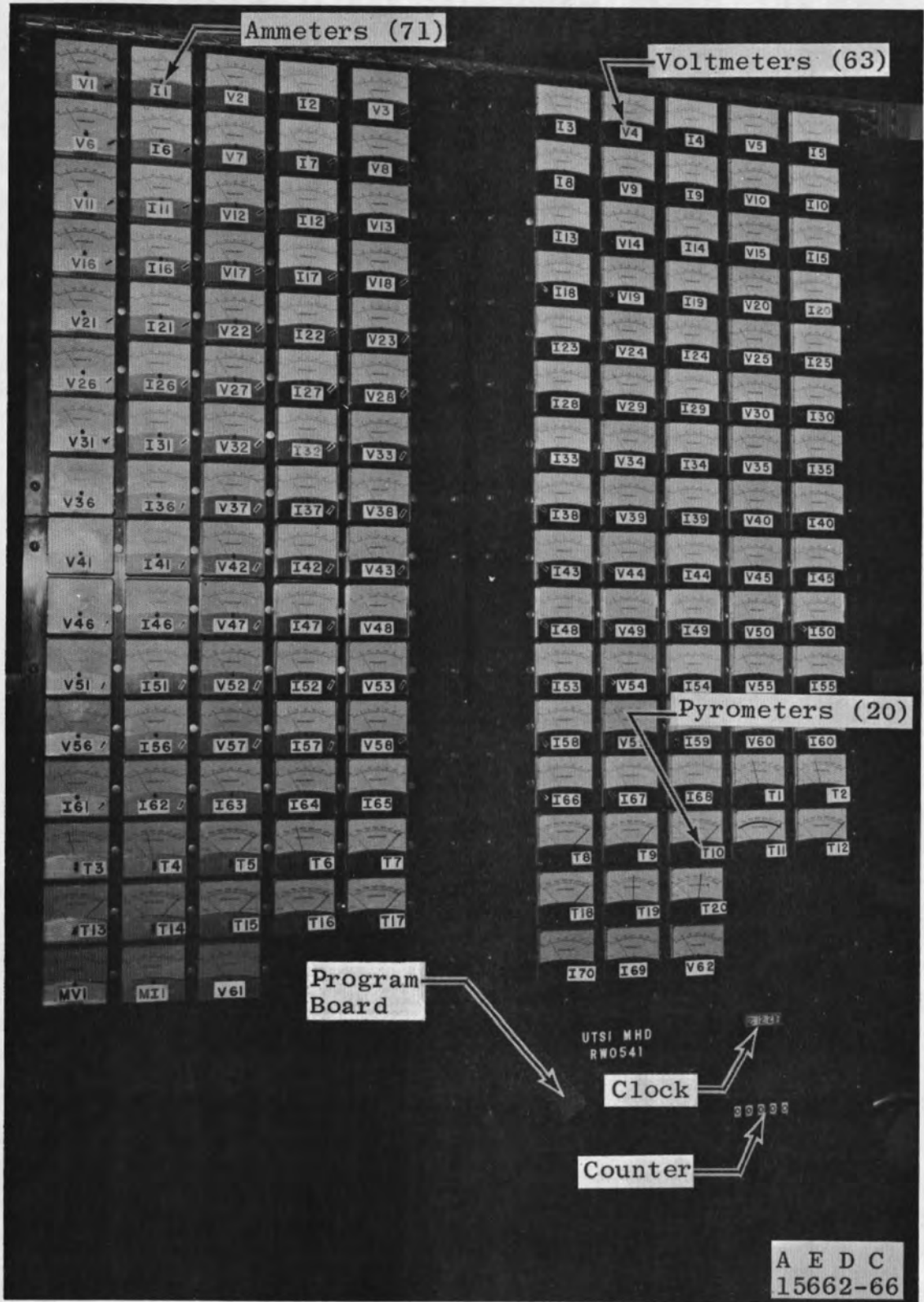

Fig. 16 Photograph of Meter Panel

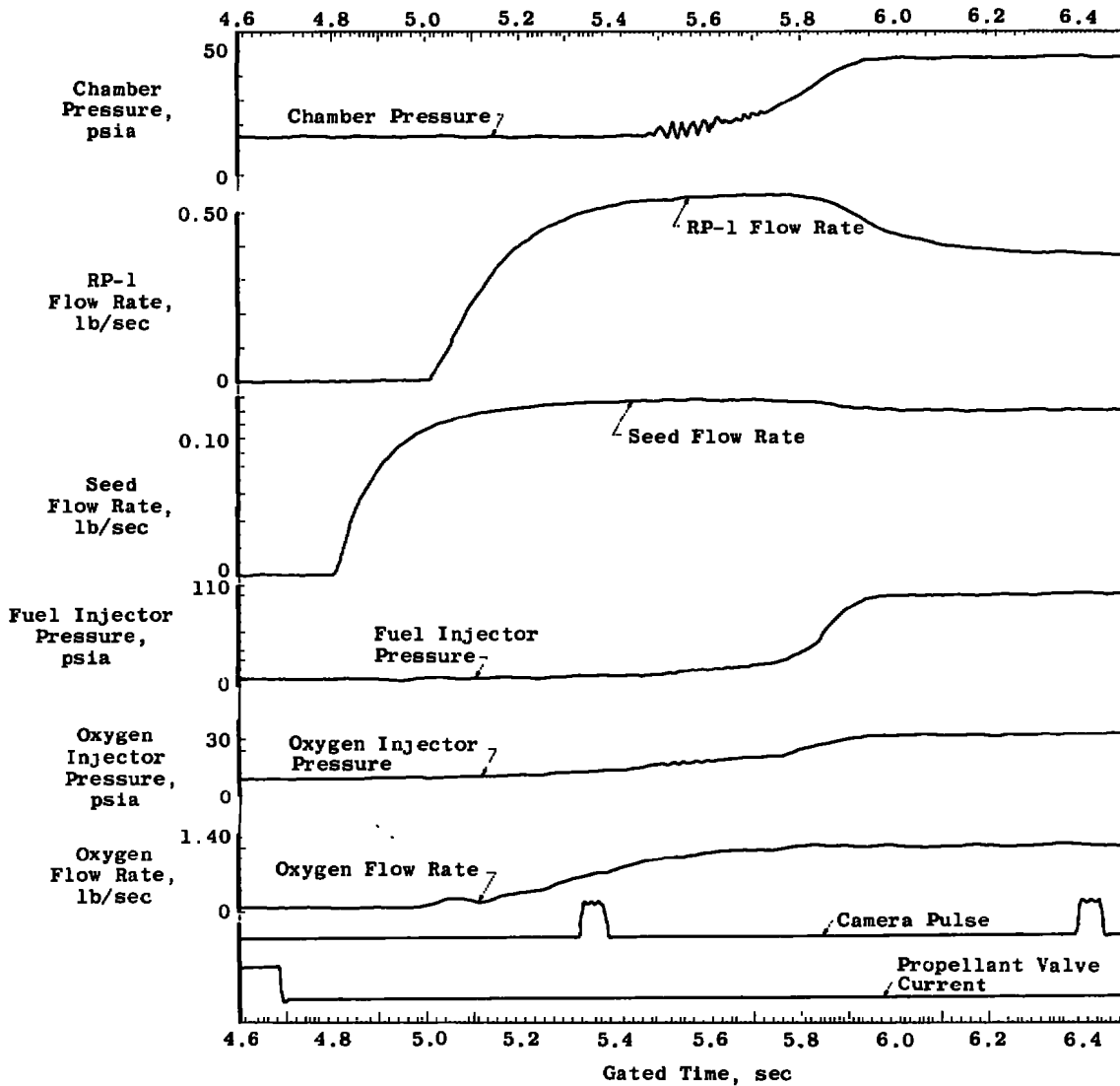

Fig. 17 Typical Engine Ignition Transient

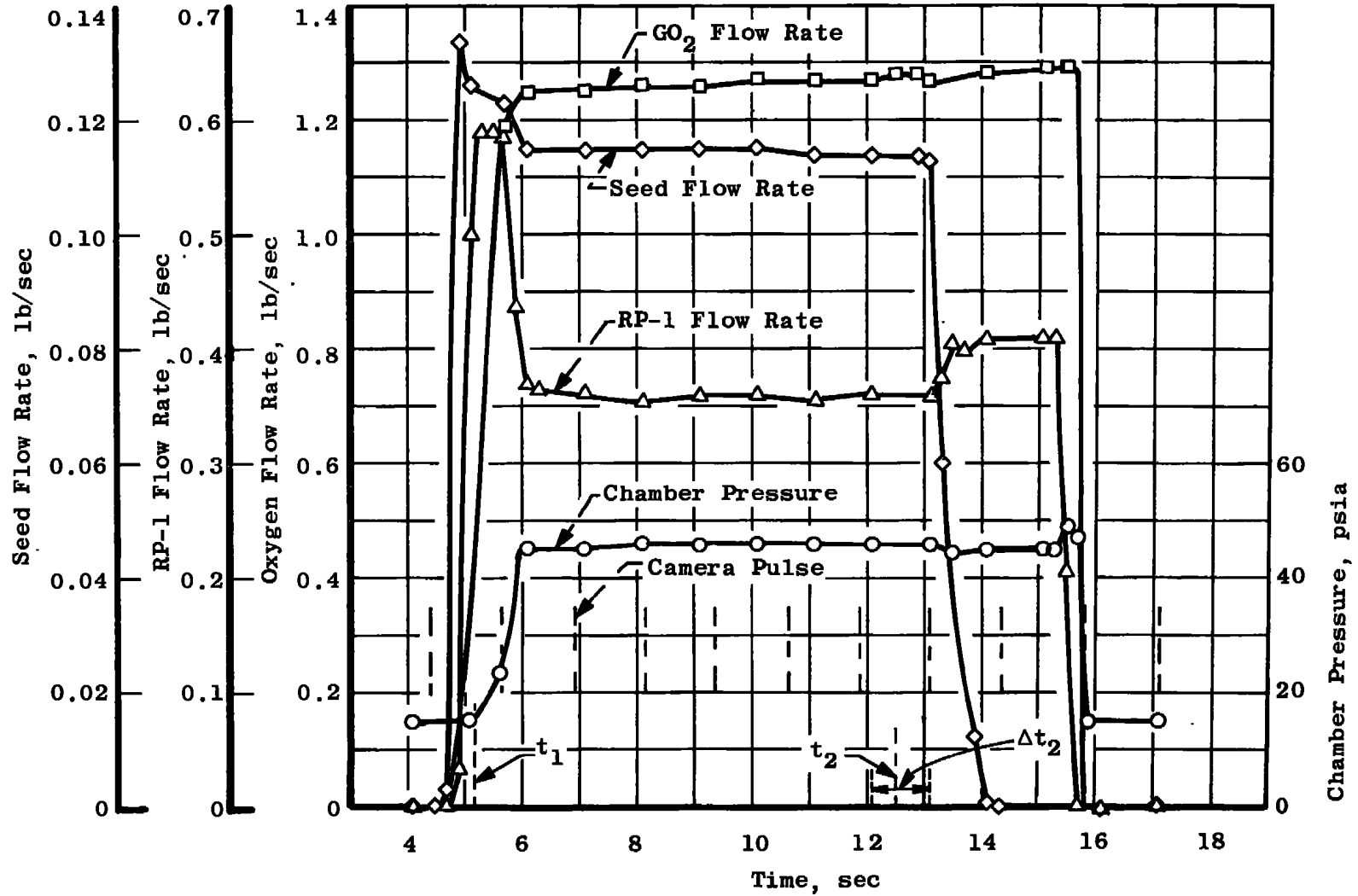
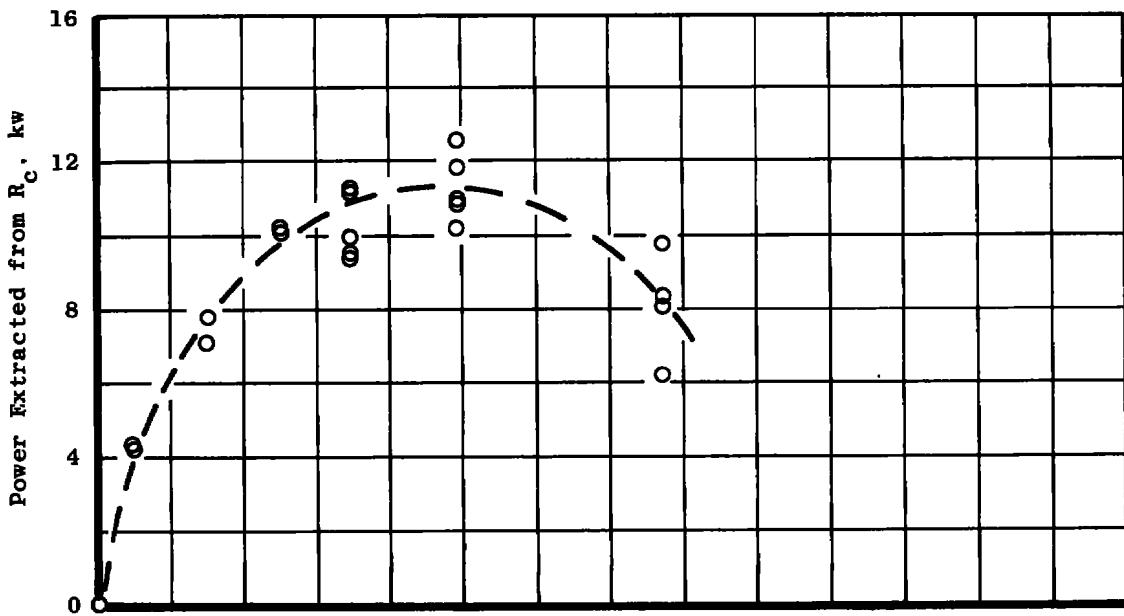
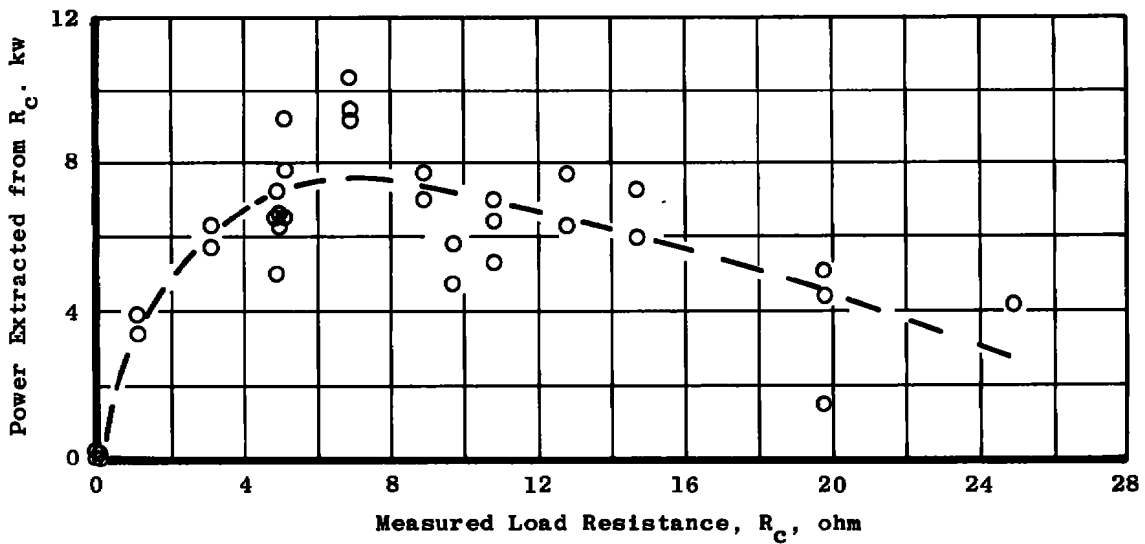

Fig. 18 Combustor Chamber Pressure and Seed and Propellant Flow Rates during a Typical Firing



a. Test Series 59 through 63 (R_c between Elements 5 and 57)



b. Test Series 64 through 69 (R_c between Elements 3 and 58)

Fig. 19 Generated Power as a Function of Load Resistance

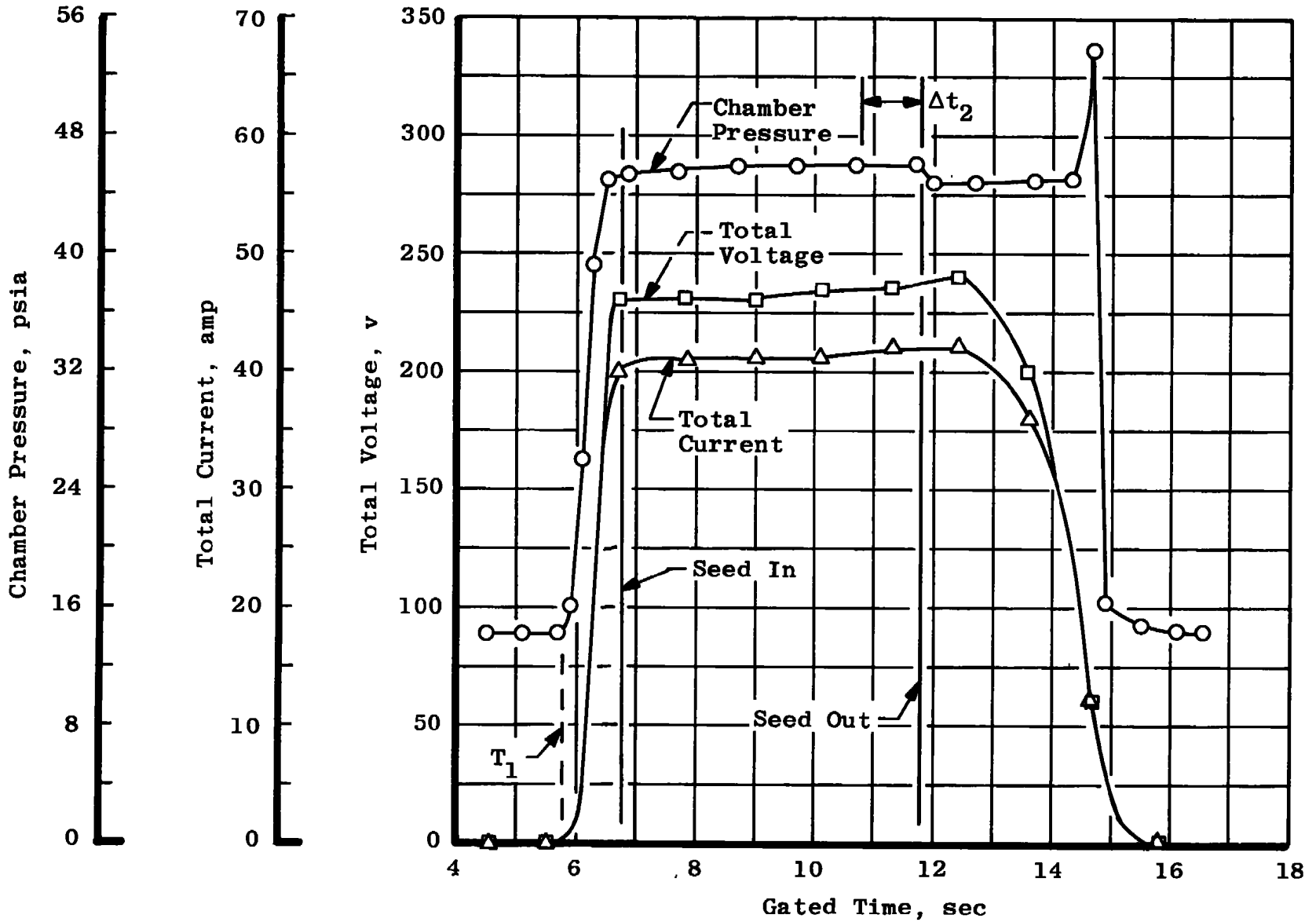

Fig. 20 Chamber Pressure, Total Voltage, and Total Current during a Typical Firing

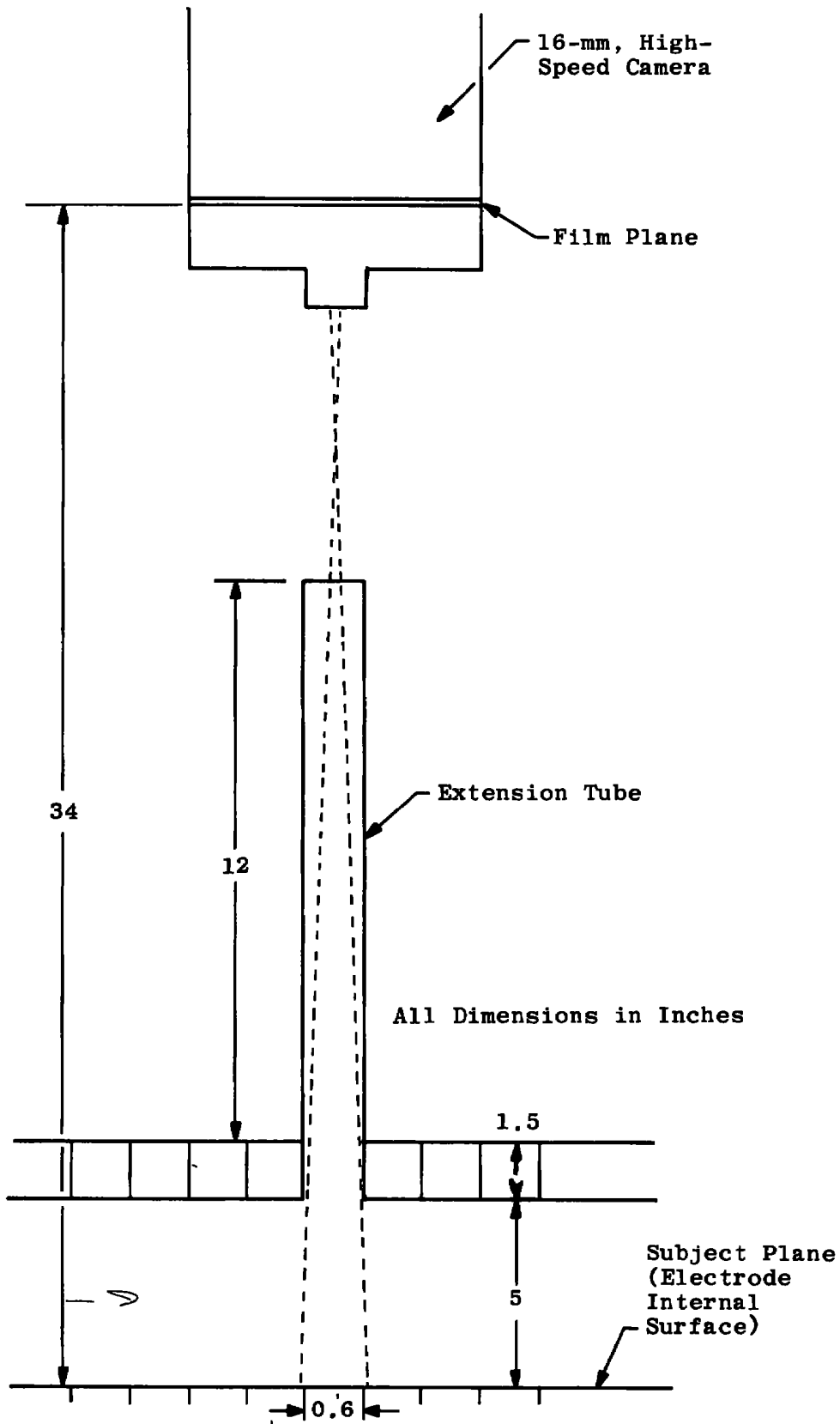

Fig. 21 Schematic of High-Speed Camera Installation

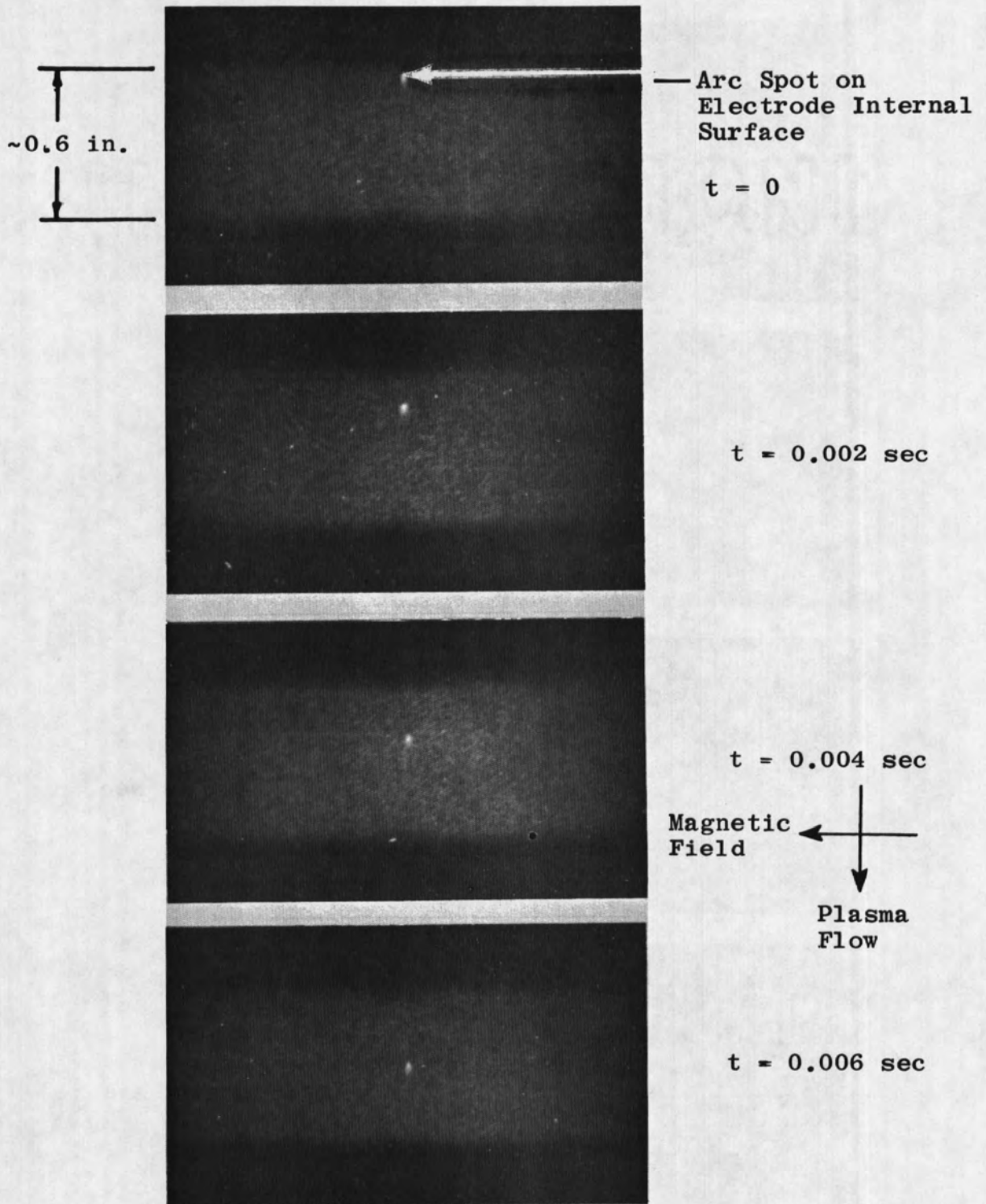
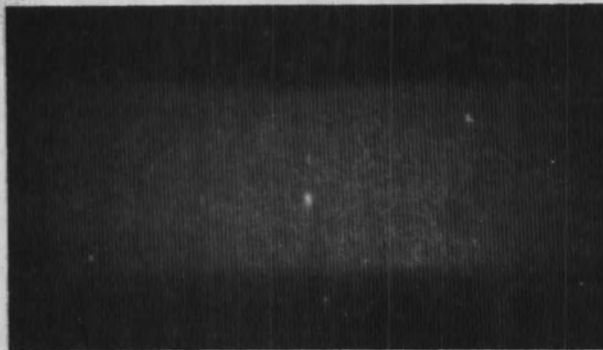

Fig. 22 Photographs Showing Electrode Arc "Spot"
Crossing Cathode Surface



$t = 0.008 \text{ sec}$



$t = 0.010 \text{ sec}$

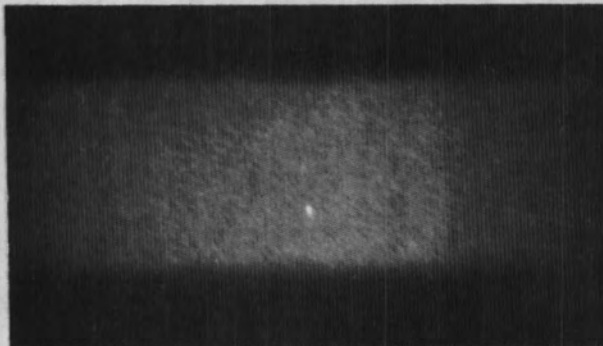

$t = 0.012 \text{ sec}$

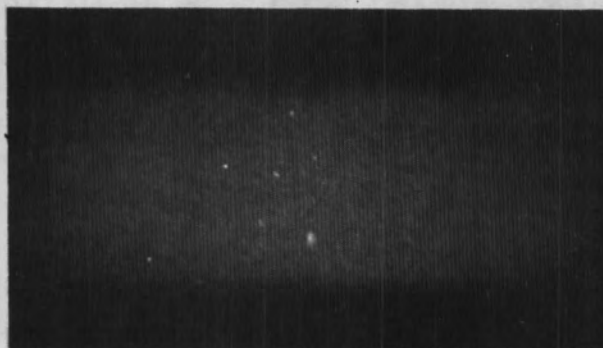

$t = 0.014 \text{ sec}$

Fig. 22 Concluded

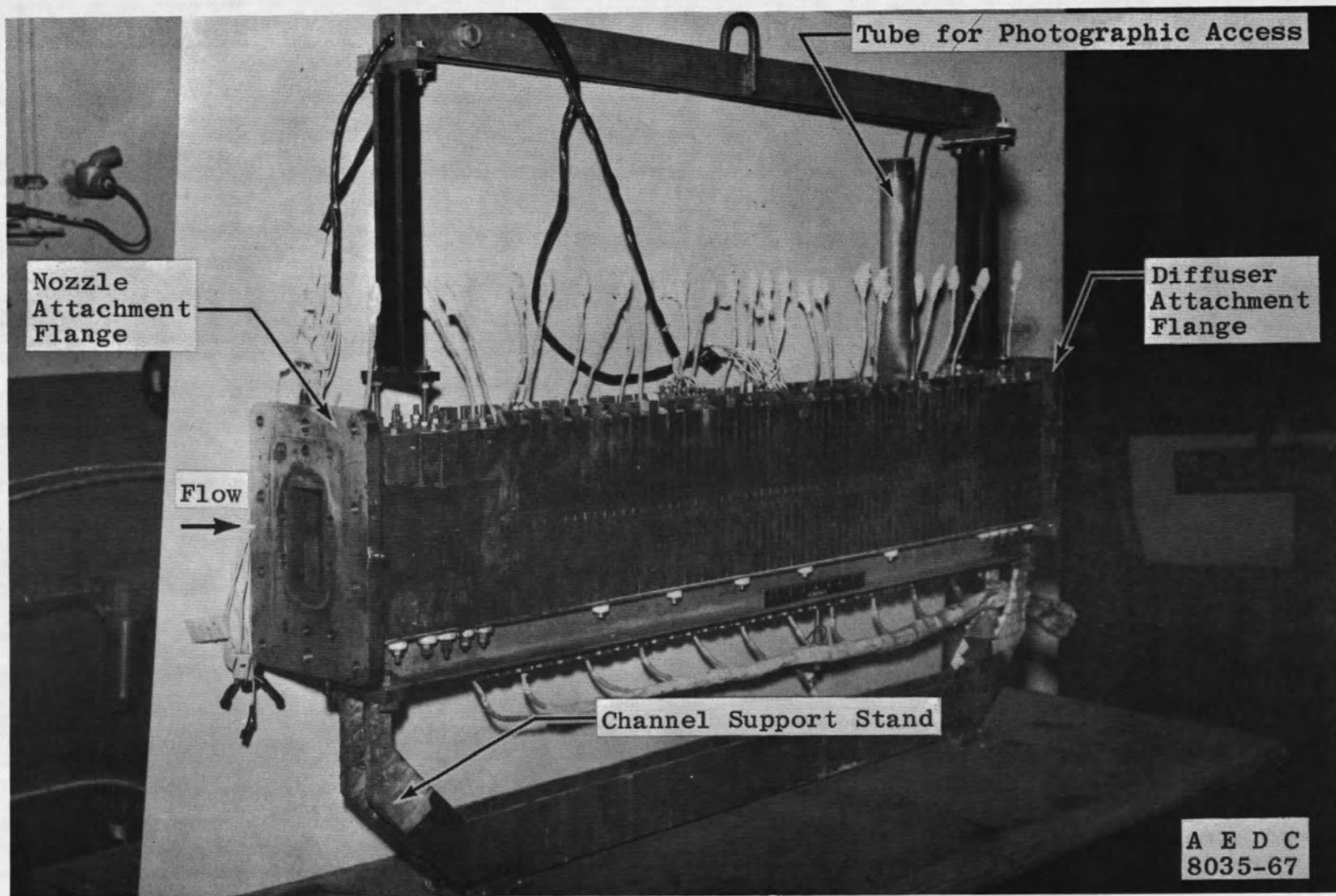

a. Overall View

Fig. 23 Post-Fire Photographs of Hall Channel

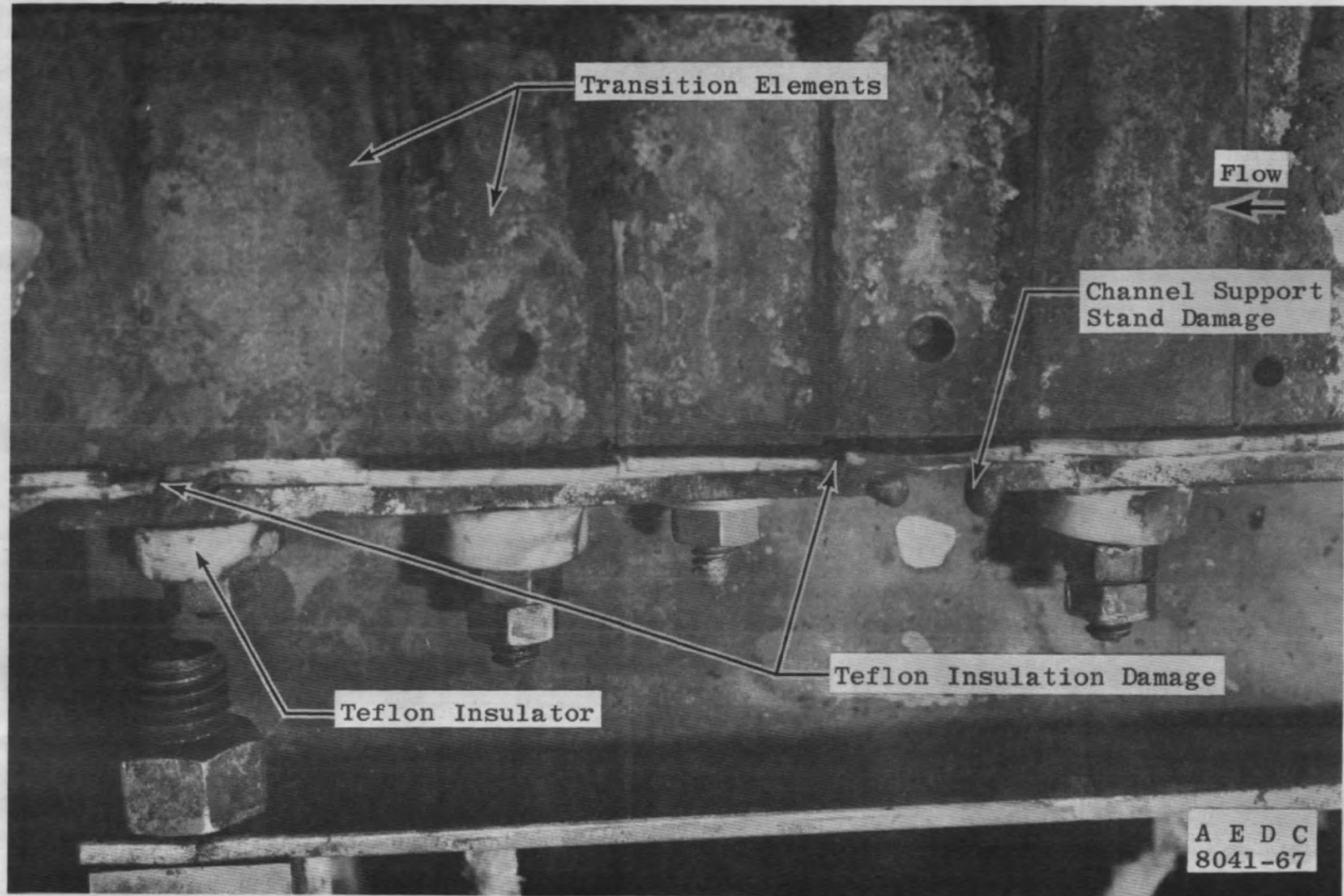

b. Damage Caused by Arcing

Fig. 23 Continued

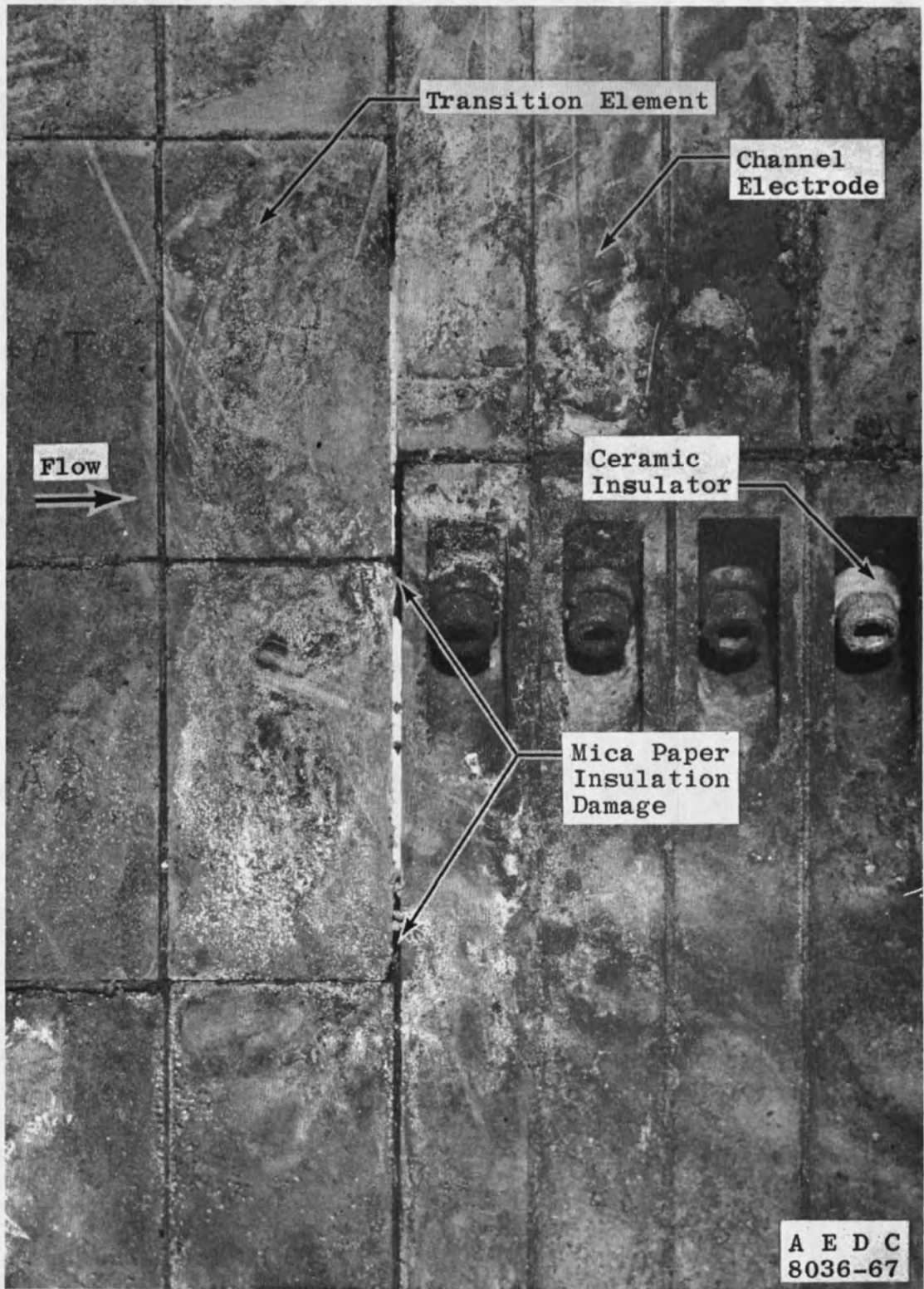

c. Detailed View Showing Mica Paper Insulation Damage

Fig. 23 Concluded

**TABLE I
INSTRUMENTATION**

Parameter	Estimate of Measurement Uncertainty at Operating Level, percent *	Measuring Device	Range of Measuring Device	Recording Method
Chamber Pressure	±0.75	Bonded Strain-Gage-Type Transducer	0-50 psia 0-100 psia	Millivolt-to-Frequency Converter onto Magnetic Tape
Venturi Upstream Pressure	±1	"	0-300 psia	"
RP-1 Flow Rate	±0.5	Turbine-Type Flowmeter	0-1.0 lb/sec	"
Seed Flow Rate	±0.5	"	0-0.16 lb/sec	"
Oxygen Flow Rate	±2	Venturi	---	"
Injector Pressures	±1	Bonded Strain-Gage-Type Transducer	0-200 psia 0-25 psia	"
Channel Pressure	±1	"	0-30 psia 0-50 psia	Low Level Multiplexed Analog-to-Digital Converter onto Magnetic Tape
			0-50 psia	"
RP-1 Tank Pressure	±1	"	0-500 psia	"
Seed Tank Pressure	±1	"	0-500 psia	"
Channel Voltage	±1	Voltmeter	-20-100v	Timer Actuated Camera onto 70-mm Film
Magnet Voltage	±1	"	0-120v	"
Channel Current	±1	Ammeter	-20-100a	"
Magnet Current	±1	"	0-2000a	"
Time	---	Synchronous Timing Generator	---	Photographically Recording Galvanometer-Type Oscillograph

*Uncertainties at an estimated two-standard-deviation level.

**TABLE II
SUMMARY OF OPERATING CONDITIONS**

Run Number*	Magnet		Nominal Chamber Pressure, psia	Measured Load Bank Resistance, ohms		Nominal Percent KOH of Total Flow Rate
	Field Strength, kilogauss	Polarity		R _{center}	R _{total}	
59.2	20	Normal	46	9.82	11.2	1.3
59.3				↓	↓	
59.4						
59.5						
59.6				↓	↓	
60.1				15.4	16.8	
61.2				↓	↓	
61.3						
61.4				↓	↓	
61.5				6.93	8.35	
61.7		↓				
62.1		Reversed				
62.2				↓	↓	
62.3						
62.4				5.03	6.45	
62.5				5.03	6.45	
63.1				2.99	4.41	
63.2				2.99	4.41	
63.3				1.04	2.46	
63.4				1.04	2.46	
63.5				0	1.42	
63.6		↓		0	1.42	
64.1		Normal		6.93	6.93	
64.2				↓	↓	
64.3						
65.6				5.06	5.06	
66.1				↓	↓	
66.2						
66.3				↓	↓	
66.4	↓	↓	↓	3.07	3.07	↓

TABLE II (Concluded)

Run Number*	Magnet		Nominal Chamber Pressure, psia	Measured Load Bank Resistance, ohms		Nominal Percent KOH of Total Flow Rate
	Field Strength, Kilogauss	Polarity		R _{center}	R _{total}	
66.5	20	Normal	46	3.07	3.07	1.3
66.6				1.05	1.05	
66.7				1.05	1.05	
66.8				0	0	
66.9				0	0	
66.10				8.87	8.87	
66.11				8.87	8.87	
67.1				10.8	10.8	
67.2				↓	↓	
67.3				↓	↓	
67.5				12.8	12.8	
67.7				↓	↓	
67.8				14.7	14.7	
67.9				14.7	14.7	
67.10				24.9	24.9	
68.1				4.87	4.87	
68.2				↓	↓	
68.3				↓	↓	
68.4		↓		19.8	19.8	
68.5		Normal		↓	↓	
68.6		Reversed		↓	↓	
69.1		Normal		0	0	
69.2		↓		↓	↓	
69.3		↓		↓	↓	
69.4		↓		5.03	5.03	
69.5		Normal		9.73	9.73	
69.6		Reversed		9.73	9.73	
69.7		↓		5.03	5.03	
69.8		↓	↓	0	0	↓

*Number to left of decimal denotes run sequence.
 Number after decimal denotes order of firings in each sequence.

TABLE III
SUMMARY OF COMBUSTOR PERFORMANCE

Run Number	t ₁ ,* sec	t ₂ ** sec	Average Combustor Conditions at t ₂			
			P _{ch} , psia	W _{O₂} , lb/sec	W _{RP-1} , lb/sec	W _{seed} , lb/sec
59.2	5.7	13.9	45.9	1.270	0.354	0.112
59.3	↓	14.5	46.1	1.268	0.359	0.112
59.4	↓	14.3	46.1	1.267	0.356	0.113
59.5	↓	13.9	46.0	1.264	0.361	0.111
59.6	↓	14.3	46.1	1.260	0.365	0.112
60.1	5.9	12.3	46.5	1.255	0.338	0.112
61.2	↓	12.3	44.8	1.268	0.339	0.111
61.3	↓	12.5	46.0	1.268	0.361	0.113
61.4	↓	12.3	44.7	1.267	0.347	0.111
61.5	↓	11.9	45.3	1.263	0.355	0.112
61.7	↓	12.7	45.4	1.267	0.351	0.113
62.1	↓	12.3	46.3	1.274	0.365	0.113
62.2	↓	12.1	46.3	1.268	0.353	0.110
62.3	↓	12.3	46.1	1.273	0.362	0.114
62.4	↓	12.5	46.2	1.273	0.364	0.112
62.5	↓	12.3	46.2	1.276	0.363	0.114
63.1	↓	12.7	46.7	1.258	0.368	0.114
63.2	↓	12.1	46.7	1.264	0.369	0.115
63.3	↓	12.1	46.8	1.263	0.353	0.114
63.4	↓	12.3	46.6	1.256	0.365	0.115
63.5	↓	12.1	46.6	1.259	0.350	0.116
63.6	↓	12.5	46.6	1.265	0.347	0.116
64.1	5.1	11.5	46.5	1.277	0.364	0.114
64.2	5.3	11.5	46.3	1.274	0.362	0.114
64.3	↓	11.5	46.3	1.276	0.363	0.114
65.6	↓	8.9	46.0	1.270	0.375	0.115
66.1	5.1	11.3	46.3	1.275	Void	0.114
66.2	↓	↓	46.0	Void	Void	Void
66.3	↓	↓	46.3	1.275	0.358	0.115
66.4	↓	↓	46.2	1.272	0.365	0.114
66.5	↓	↓	46.2	1.267	0.360	0.113

TABLE III (Concluded)

Run Number	t ₁ ,* sec	t ₂ ** sec	Average Combustor Conditions at t ₂			
			P _{ch} , psia	W _{O₂} , lb/sec	W _{RP-1} , lb/sec	W _{seed} , lb/sec
66.6	5.1	11.3	46.4	1.273	0.364	0.113
66.7	↓	↓	46.3	1.267	0.365	0.113
66.8	↓	↓	46.2	1.275	0.361	0.114
66.9	↓	↓	46.2	1.267	0.364	0.113
66.10	↓	↓	46.2	1.272	0.361	0.115
66.11	↓	↓	46.2	1.266	0.361	0.113
67.1	↓	11.5	46.5	1.281	0.366	0.113
67.2	↓	11.3	46.4	1.274	0.362	0.113
67.3	↓	↓	46.6	1.280	0.364	0.113
67.5	↓	↓	46.7	1.284	0.366	0.113
67.7	↓	↓	46.5	1.283	0.356	0.111
67.8	↓	↓	46.3	1.274	0.356	0.113
67.9	↓	↓	46.4	1.279	0.355	0.113
67.10	↓	10.4	46.5	1.285	0.356	0.113
68.1	↓	11.3	46.2	1.268	0.361	0.116
68.2	↓	↓	46.4	1.270	0.364	0.114
68.3	↓	↓	46.6	1.271	0.366	0.115
68.4	↓	↓	46.5	1.269	0.367	0.114
68.5	↓	↓	46.3	1.270	0.365	0.116
68.6	↓	↓	46.4	1.273	0.370	0.116
69.1	↓	↓	46.5	1.277	0.364	0.115
69.2	↓	↓	46.2	1.276	0.359	0.116
69.3	↓	9.7	46.2	1.275	0.357	0.116
69.4	↓	↓	46.2	1.272	0.335	0.113
69.5	↓	11.3	46.2	1.276	0.356	0.116
69.6	↓	↓	46.0	1.274	0.356	0.116
69.7	↓	↓	46.3	1.279	0.360	0.115
69.8	↓	↓	46.1	1.275	0.359	0.116

*Initiation of chamber pressure increase

**Midpoint of 1-sec time interval (Δt_2) prior to seed flow shutoff

TABLE IV
SUMMARY OF MEASURED LOAD BANK RESISTANCES

Run Number	Measured Resistance, ohms							
	R1	R2	R3	R4	R _C	R34	R35	R36
59.2	0.177	0.200	0.200	0.235	9.82	0.170	0.150	0.095
59.3	↓	↓	↓	↓	↓	↓	↓	↓
59.4	↓	↓	↓	↓	↓	↓	↓	↓
59.5	↓	↓	↓	↓	↓	↓	↓	↓
59.6	↓	↓	↓	↓	↓	↓	↓	↓
60.1	↓	↓	↓	↓	15.4	↓	↓	↓
61.2	↓	↓	↓	↓	↓	↓	↓	↓
61.3	↓	↓	↓	↓	↓	↓	↓	↓
61.4	↓	↓	↓	↓	↓	↓	↓	↓
61.5	↓	↓	↓	↓	6.93	↓	↓	↓
61.7	↓	↓	↓	↓	↓	↓	↓	↓
62.1	↓	↓	↓	↓	↓	↓	↓	↓
62.2	↓	↓	↓	↓	↓	↓	↓	↓
62.3	↓	↓	↓	↓	↓	↓	↓	↓
62.4	↓	↓	↓	↓	5.03	↓	↓	↓
62.5	↓	↓	↓	↓	5.03	↓	↓	↓
63.1	↓	↓	↓	↓	2.99	↓	↓	↓
63.2	↓	↓	↓	↓	2.99	↓	↓	↓
63.3	↓	↓	↓	↓	1.04	↓	↓	↓
63.4	↓	↓	↓	↓	1.04	↓	↓	↓
63.5	↓	↓	↓	↓	0	↓	↓	↓
63.6	↓	↓	↓	↓	0	↓	↓	↓
64.1	---	---	---	---	6.93	---	---	---
64.2	---	---	---	---	↓	---	---	---
64.3	---	---	---	---	↓	---	---	---
65.6	---	---	---	---	5.06	---	---	---
66.1	---	---	---	---	↓	---	---	---
66.2	---	---	---	---	↓	---	---	---
66.3	---	---	---	---	↓	---	---	---

TABLE IV (Concluded)

Run Number	Measured Resistance, ohms							
	R1	R2	R3	R4	R _C	R34	R35	R36
66.4	---	---	---	---	3.07	---	---	---
66.5	---	---	---	---	3.07	---	---	---
66.6	---	---	---	---	1.05	---	---	---
66.7	---	---	---	---	1.05	---	---	---
66.8	---	---	---	---	0	---	---	---
66.9	---	---	---	---	0	---	---	---
66.10	---	---	---	---	8.87	---	---	---
66.11	---	---	---	---	8.87	---	---	---
67.1	---	---	---	---	10.8	---	---	---
67.2	---	---	---	---	↓	---	---	---
67.3	---	---	---	---	↓	---	---	---
67.5	---	---	---	---	12.8	---	---	---
67.7	---	---	---	---	12.8	---	---	---
67.8	---	---	---	---	14.7	---	---	---
67.9	---	---	---	---	14.7	---	---	---
67.10	---	---	---	---	24.9	---	---	---
68.1	---	---	---	---	4.87	---	---	---
68.2	---	---	---	---	↓	---	---	---
68.3	---	---	---	---	↓	---	---	---
68.4	---	---	---	---	19.8	---	---	---
68.5	---	---	---	---	↓	---	---	---
68.6	---	---	---	---	↓	---	---	---
69.1	---	---	---	---	0	---	---	---
69.2	---	---	---	---	0	---	---	---
69.3	---	---	---	---	0	---	---	---
69.4	---	---	---	---	5.03	---	---	---
69.5	---	---	---	---	9.73	---	---	---
69.6	---	---	---	---	9.73	---	---	---
69.7	---	---	---	---	5.03	---	---	---
69.8	---	---	---	---	0	---	---	---

TABLE V
SUMMARY OF CHANNEL ELECTRICAL MEASUREMENTS
a. Channel-to-Load Bank

Run Number	Magnet Field Strength, kilogauss	Magnet Current, amps	Time, T ₂ sec	Current, Channel-To-Load Bank, amp										
				Element 5-57, R _c Current, I ₆₉	Element 3-38, R _c Current, I ₆₉	Element 1 I ₂	Element 2 I ₄	Element 3 I ₆	Element 4 I ₈	Element 5 I ₁₀	Element 57 I ₆₁	Element 58 I ₆₃	Element 59 I ₆₅	Element 60 I ₆₇
59.2	20	1200	13.9	32	---	11	4	4	2	8	5	5	7	13
59.3			14.5	36	---	11	6	4	3	9	6	5	10	12
59.4			14.3	35	---	10	5	4	4	10	6	4	9	14
59.5			13.9	33	---	10	4	4	4	8	6	4	7	14
59.6			14.3	33	---	10	6	4	3	8	6	5	7	14
60.1			12.3	24	---	6	4	2	3	5	3	2	10	7
61.2			12.3	20	---	6	3	1	4	6	1	2	10	6
61.3			12.5	25	---	9	4	2	4	6	4	3	6	12
61.4			12.3	23	---	8	2	3	2	6	4	3	4	10
61.5			11.9	36	---	10	4	5	4	10	8	6	7	14
61.7			12.7	37	---	11	4	4	5	10	8	5	10	11
62.1			12.3	36	---	12	3	2	3	11	11	3	7	12
62.2			12.1	40	---	12	4	4	4	10	10	5	8	14
62.3			12.3	40	---	12	6	4	4	10	10	6	7	14
62.4			12.5	44	---	13	4	4	4	15	11	7	8	16
62.5			12.3	44	---	14	3	4	5	14	12	7	8	14
63.1			12.7	47	---	15	4	4	4	17	14	8	9	14
63.2			12.1	49	---	16	5	4	5	18	15	10	10	15
63.3			12.1	60	---	16	6	6	6	22	16	12	11	18
63.4			12.3	61	---	17	5	6	7	24	18	12	10	19
63.5			12.1	64	---	17	6	6	7	26	18	13	11	21
63.6			12.5	68	---	20	6	7	8	26	20	13	12	21
64.1			11.5	---	36	15	10	10	---	---	---	6	10	20
64.2			11.5	---	38	14	10	10	---	---	---	8	10	16
64.3			11.5	---	36	14	12	10	---	---	---	8	9	19
65.6			8.9	---	36	9	9	15	---	---	---	4	6	25
66.1			11.3	---	36	11	10	13	---	---	---	6	6	22
66.2			11.3	---	39	15	10	10	---	---	---	10	10	18
66.3			11.3	---	42	16	13	12	---	---	---	10	11	21
66.4			11.3	---	44	18	11	12	---	---	---	12	11	20

TABLE V
a. Concluded

Run Number	Magnet Field Strength, kilogauss	Magnet Current, amp	Time, T ₂ , sec	Current, Channel-To-Load Bank, amp										
				Element 5-57, R _c Current, I ₆₉	Element 3-58, R _c Current, I ₆₉	Element 1 I ₁₂	Element 2 I ₁₄	Element 3 I ₁₆	Element 4 I ₁₈	Element 5 I ₁₁₀	Element 57 I ₁₆₁	Element 58 I ₁₆₃	Element 59 I ₁₆₅	Element 60 I ₁₆₇
66.5	20	1200	11.3	---	45	21	11	12	---	---	---	12	12	22
66.6				---	57	26	14	16	---	---	---	14	14	28
66.7				---	60	29	14	14	---	---	---	14	15	30
66.8				---	61	37	23	0	---	---	---	14	15	31
66.9				---	67	43	22	0	---	---	---	16	16	33
66.10				---	28	11	7	10	---	---	---	7	8	13
66.11				---	29	12	8	8	---	---	---	7	8	14
67.1			11.5	---	22	5	8	8	---	---	---	6	4	12
67.2			11.3	---	24	8	8	6	---	---	---	7	6	11
67.3				---	25	8	10	8	---	---	---	6	8	12
67.5				---	22	8	8	6	---	---	---	7	7	9
67.7				---	24	9	8	6	---	---	---	6	7	11
67.8				---	20	7	7	6	---	---	---	5	6	10
67.9				---	22	8	9	5	---	---	---	6	7	10
67.10			10.4	---	13	4	6	2	---	---	---	3	5	5
68.1			11.3	---	31	7	8	12	---	---	---	6	6	18
68.2				---	36	12	10	12	---	---	---	8	8	19
68.3				---	38	12	12	12	---	---	---	9	10	18
68.4				---	16	1	6	8	---	---	---	1	4	10
68.5				---	15	0	7	6	---	---	---	0	4	9
68.6				---	8	-6	3	12	---	---	---	6	4	0
69.1				---	54	24	10	18	---	---	---	20	8	24
69.2				---	60	27	13	17	---	---	---	22	13	22
69.3			9.7	---	64	32	12	16	---	---	---	20	14	28
69.4			9.7	---	35	12	8	11	---	---	---	9	8	16
69.5			11.3	---	21	6	7	8	---	---	---	4	5	12
69.6				---	24	4	4	14	---	---	---	10	6	7
69.7				---	36	14	6	14	---	---	---	9	12	14
69.8				---	58	28	9	18	---	---	---	14	16	26

TABLE V
b. Element Top-to-Element Bottom

Run Number	Time, T ₂ , sec	Current, Element Top-To-Element Bottom, amp																									
		Element 1 I ₁	Element 2 I ₃	Element 3 I ₅	Element 4 I ₇	Element 5 I ₉	Element 6 I ₁₁	Element 7 I ₁₃	Element 9 I ₁₅	Element 11 I ₁₇	Element 13 I ₁₉	Element 15 I ₂₁	Element 17 I ₂₃	Element 19 I ₂₅	Element 22 I ₂₇	Element 23 I ₂₉	Element 25 I ₃₁	Element 27 I ₃₂	Element 29 I ₃₃	Element 31 I ₃₄	Element 34 I ₃₅	Element 35 I ₃₆	Element 37 I ₃₈	Element 40 I ₄₀	Element 41 I ₄₂	Element 43 I ₄₄	Element 45 I ₄₆
59.2	13.9	17	14	12	12	12	10	8	11	10	10	11	14	12	4	16	13	13	13	12	13	13	14	11	11	14	10
59.3	14.5	18	13	12	11	13	10	8	9	10	10	10	14	12	4	16	12	14	13	12	13	14	14	12	12	14	10
59.4	14.3	14	11	10	10	10	8	6	8	8	8	9	11	10	5	13	10	12	11	10	12	12	13	12	10	14	10
59.5	13.9	18	14	12	12	14	11	8	10	10	11	11	15	12	4	16	14	15	12	13	13	13	14	12	11	14	11
59.6	14.3	18	14	10	12	13	10	8	9	9	11	11	14	12	5	16	14	15	12	13	13	13	13	12	11	14	11
60.1	12.3	12	10	8	8	11	8	7	8	9	7	8	13	11	6	14	9	13	11	9	13	11	12	12	10	13	8
61.2	12.3	10	6	6	6	8	5	5	5	7	6	6	8	8	6	10	7	9	8	8	11	10	10	9	11	8	8
61.3	12.5	15	10	10	8	10	10	8	9	9	8	9	13	12	8	14	10	13	11	11	14	12	12	10	14	10	10
61.4	12.3	12	6	7	7	8	7	6	7	8	8	8	10	10	6	11	10	10	10	10	12	11	11	10	10	12	10
61.5	11.9	16	8	10	8	12	8	6	7	8	9	9	10	10	6	12	10	11	10	10	12	11	11	10	10	12	10
61.7	12.7	16	8	10	8	11	8	6	7	8	8	8	10	10	6	12	10	12	10	10	12	11	12	11	10	12	10
62.1	12.3	-6	-6	-7	-6	-4	-6	-6	-4	-9	-8	-10	-11	-8	-14	-12	-14	-11	-10	-9	-13	-10	-11	-13	-9	-11	-12
62.2	12.1	-7	-6	-6	-6	-4	-6	-8	-7	-10	-9	-11	-12	-11	-14	-14	-14	-12	-10	-10	-14	-12	-12	-13	-10	-12	-12
62.3	12.3	-8	-6	-6	-6	-4	-8	-9	-8	-11	-9	-11	-12	-11	-16	-14	-14	-12	-12	-11	-13	-12	-11	-12	-10	-12	-12
62.4	12.5	-10	-6	-7	-6	-4	-7	-7	-6	-11	-8	-10	-12	-11	-14	-14	-14	-12	-12	-12	-12	-12	-12	-12	-10	-12	-12
62.5	12.3	-8	-8	-6	-5	-4	-7	-6	-6	-10	-8	-10	-12	-10	-14	-13	-14	-12	-10	-10	-12	-13	-12	-13	-10	-12	-11
63.1	12.7	-4	-8	-8	-4	-3	-5	-6	-7	-7	-7	-7	-12	-8	-14	-14	-12	-9	-9	-10	-12	-10	-11	-11	-9	-11	-10
63.2	12.1	-6	-6	-8	-4	-3	-7	-8	-9	-10	-8	-9	-12	-11	-16	-14	-11	-11	-11	-12	-13	-10	-12	-12	-10	-12	-10
63.3	12.1	-7	-7	-7	-4	-2	-4	-6	-7	-8	-8	-8	-12	-10	-12	-13	-10	-10	-10	-11	-12	-10	-12	-12	-10	-12	-10
63.4	12.3	-8	-8	-7	-4	-2	-6	-8	-9	-10	-8	-9	-12	-11	-14	-14	-10	-12	-11	-12	-13	-10	-12	-12	-10	-13	-10
63.5	12.1	-6	-8	-8	-4	-1	-4	-6	-6	-8	-7	-7	-10	-8	-10	-12	-9	-10	-10	-10	-10	-10	-10	-10	-9	-11	-9
63.6	12.5	-7	-8	-7	-4	-2	-6	-7	-9	-9	-8	-8	-12	-10	-12	-14	-10	-10	-10	-10	-12	-10	-12	-12	-10	-12	-9
64.1	11.5	20	13	12	6	10	8	7	9	10	6	7	13	12	7	13	10	13	11	11	14	12	13	12	10	13	8
64.2	11.5	21	14	12	7	8	10	8	9	10	10	11	14	13	10	13	12	13	12	13	14	12	12	12	10	13	10
64.3	11.5	21	14	13	8	10	10	10	11	10	12	11	15	14	7	15	14	14	12	12	14	12	12	13	11	14	10
65.6	8.9	14	11	14	6	8	8	8	9	9	8	9	10	11	5	14	10	13	10	10	11	12	11	12	10	14	8
66.1	11.3	17	13	12	4	8	8	6	8	8	5	6	11	12	4	14	8	12	10	8	12	10	12	10	10	13	9
66.2	11.3	22	14	12	0	8	9	8	10	10	9	8	12	13	10	12	10	12	10	10	13	11	12	12	12	12	8

TABLE V
b. Continued

Run Number	Time, T ₂ , sec	Current, Element Top-To-Element Bottom, amp																									
		Element 1 11	Element 2 13	Element 3 15	Element 4 17	Element 5 19	Element 6 111	Element 7 113	Element 9 115	Element 11 117	Element 13 119	Element 15 121	Element 17 123	Element 19 125	Element 22 127	Element 23 129	Element 25 131	Element 27 132	Element 29 133	Element 31 134	Element 34 135	Element 35 136	Element 37 138	Element 40 140	Element 41 142	Element 43 144	Element 45 146
66.3	11.3	23	16	14	3	8	9	7	10	8	10	9	13	11	6	14	12	13	10	12	14	11	12	12	10	12	10
66.4		23	14	14	4	8	8	8	9	8	10	9	12	12	9	12	11	12	10	11	13	10	11	12	10	12	10
66.5		26	16	14	5	8	10	8	10	8	10	10	13	12	10	12	11	12	10	11	13	11	12	11	10	12	10
66.6		30	17	16	4	7	8	8	9	8	10	8	13	12	10	12	11	11	10	10	13	10	11	10	10	10	10
66.7		32	16	16	5	8	9	8	10	8	10	8	13	11	11	12	11	12	10	11	13	10	12	11	10	12	10
66.8		34	23	3	4	7	8	6	8	7	8	8	11	11	12	11	10	10	10	10	12	10	10	10	10	10	10
66.9		14	22	6	6	8	9	8	9	8	8	8	13	11	12	11	10	11	10	10	13	10	11	10	10	10	10
66.10		19	13	13	6	9	10	8	10	9	10	10	14	14	8	14	13	13	12	12	14	12	12	12	10	11	10
66.11		18	14	12	8	10	10	9	10	10	11	10	14	13	8	14	14	14	12	12	14	11	12	12	10	12	10
67.1	11.5	13	11	10	4	9	10	6	10	8	6	6	12	14	10	12	10	13	10	9	12	9	12	11	10	12	8
67.2	11.3	16	12	11	6	9	10	8	10	10	11	9	14	15	8	14	13	14	11	12	14	12	12	12	10	12	8
67.3		15	14	12	6	8	10	8	9	10	10	11	14	13	8	14	14	14	11	12	14	11	12	12	10	12	10
67.5		17	12	12	5	10	10	8	10	10	8	8	14	14	12	14	13	13	12	13	14	12	13	12	11	12	10
67.7		19	14	11	6	10	11	8	10	11	8	10	14	12	14	14	14	13	12	12	14	11	13	12	10	11	10
67.8		17	12	10	6	10	11	8	10	10	8	8	14	13	13	13	10	12	10	12	14	12	14	12	11	12	10
67.9		18	14	10	7	10	12	9	11	11	10	11	15	13	14	14	13	14	12	12	14	12	14	12	10	12	10
67.10	10.4	14	11	9	7	10	11	8	9	9	8	9	13	11	11	13	10	12	10	10	14	12	11	13	10	12	9
68.1	11.3	19	12	14	5	9	11	7	9	8	6	6	12	10	---	14	8	12	10	8	2	12	12	10	11	14	8
68.2		23	14	15	4	9	10	7	9	9	8	8	12	11	---	12	10	12	10	10	5	12	14	11	11	14	10
68.3		20	16	16	6	9	10	8	9	9	10	9	13	12	---	14	12	13	11	11	6	11	16	12	11	14	10
68.4		10	11	10	7	10	10	8	9	10	11	10	13	12	---	15	13	13	12	12	2	12	14	13	12	14	11
68.5		12	10	10	6	10	9	7	9	8	6	6	11	10	---	17	10	10	10	10	3	12	14	12	12	12	12
68.6		> -20	-6	-2	-6	-6	-6	-6	-8	-10	-6	-8	-13	-10	---	-17	-11	-10	-8	-10	-19	-9	-12	-13	-8	-12	-12
69.1		28	12	16	4	8	7	5	8	7	4	4	9	10	11	9	5	9	8	6	8	8	9	8	7	10	5
69.2		30	16	17	4	8	8	6	10	9	4	6	10	11	13	10	8	11	9	8	10	10	10	10	9	10	7
69.3	9.7	36	14	18	1	8	8	7	8	8	6	7	11	10	12	10	9	10	10	10	11	10	10	10	9	10	9
69.4	9.7	20	11	12	5	9	8	6	7	8	6	5	10	8	4	11	9	10	10	8	12	10	10	10	10	10	8
69.5	11.3	17	10	11	5	9	10	8	9	8	6	6	12	10	0	14	10	11	11	9	14	11	10	10	10	11	8
69.6		-16	-4	-2	-4	-4	-6	-4	-5	-7	-6	-6	-12	-8	-16	-11	-12	-10	-8	-11	-10	-8	-12	-10	-10	-10	-11
69.7		-12	-3	-1	-4	-4	-6	-4	-7	-8	-6	-7	-11	-10	-14	-12	-12	-10	-8	-12	-11	-9	-11	-10	-10	-10	-10
69.8		-6	-2	-3	-4	-2	-5	-2	-5	-6	-4	-6	-10	-8	-6	-9	-10	-8	-7	-9	-9	-8	-10	-10	-8	-9	-10

TABLE V
b. Continued

Run Number	Time, T ₂ , sec	Current, Element Top-To-Element Bottom, amp										
		Element 47 I48	Element 49 I50	Element 52 I52	Element 53 I54	Element 54 I56	Element 55 I58	Element 56 I60	Element 57 I62	Element 58 I64	Element 59 I66	Element 60 I68
59.2	13.9	12	10	13	8	10	6	10	4	4	4	3
59.3	14.5	12	9	13	8	10	7	10	4	4	4	3
59.4	14.3	12	9	13	7	8	6	10	4	4	4	3
59.5	13.9	12	11	14	9	10	7	10	5	4	4	4
59.6	14.3	12	11	14	10	10	8	10	6	4	4	3
60.1	12.3	11	10	14	7	9	5	9	4	3	2	2
61.2	12.3	10	10	11	6	7	4	8	4	3	2	2
61.3	12.5	11	11	14	8	9	7	10	6	4	4	2
61.4	12.3	10	10	12	8	8	6	9	5	4	3	2
61.5	11.9	10	10	12	8	8	6	8	4	3	3	2
61.7	12.7	10	10	12	8	8	6	8	3	3	0	5
62.1	12.3	-5	-8	-10	-8	-10	-9	-8	-14	-9	-11	-12
62.2	12.1	-8	-9	-13	-9	-10	-10	-8	-14	-10	-12	-17
62.3	12.3	-8	-10	-14	-10	-11	-10	-8	-15	-11	-11	-17
62.4	12.5	-9	-10	-14	-10	-10	-8	-8	-14	-12	-12	-18
62.5	12.3	-10	-9	-14	-10	-10	-8	-8	-14	-12	-12	-17
63.1	12.7	-8	-9	-12	-9	-8	-7	-7	-16	-10	-11	-14
63.2	12.1	-9	-10	-14	-10	-9	-8	-8	-18	-12	-12	-17
63.3	12.1	-10	-10	-13	-8	-9	-8	-8	-18	-14	-13	-20
63.4	12.3	-10	-10	-14	-9	-10	-8	-8	-20	-14	-13	-21
63.5	12.1	-9	-10	-12	-8	-8	-6	-6	-18	-14	-13	-22
63.6	12.5	-10	-10	-12	-9	-9	-7	-7	-22	-15	-14	-22
64.1	11.5	13	10	15	6	9	6	10	4	2	2	0
64.2	11.5	13	10	14	8	10	7	9	6	2	2	3
64.3	11.5	14	12	16	9	10	8	10	7	3	3	3
65.6	8.9	12	10	12	7	9	5	9	6	3	3	0
66.1	11.3	10	8	14	5	8	5	8	5	1	2	-2
66.2	11.3	10	10	14	7	8	7	8	6	0	0	1

TABLE V
b. Concluded

Run Number	Time, T ₂ , sec	Current, Element Top-To-Element Bottom, amp										
		Element 47 I48	Element 49 I50	Element 52 I52	Element 53 I54	Element 54 I56	Element 55 I58	Element 56 I60	Element 57 I62	Element 58 I64	Element 59 I66	Element 60 I68
66.3	11.3	10	10	14	8	8	7	8	6	1	1	1
66.4		10	10	12	7	8	6	8	6	0	2	0
66.5		10	10	13	8	8	7	8	6	0	1	1
66.6		10	10	12	7	8	6	8	4	0	0	0
66.7		10	10	12	8	8	6	8	5	0	0	0
66.8		9	9	12	6	7	6	7	4	0	0	0
66.9		10	10	12	8	8	6	8	4	0	0	0
66.10		10	10	0	0	8	8	9	7	2	2	2
66.11		12	10	14	8	10	8	10	8	2	2	2
67.1	11.5	11	8	12	6	8	6	8	6	2	2	2
67.2	11.3	11	10	14	7	10	8	9	7	2	2	2
67.3		11	11	14	8	10	8	9	7	3	3	2
67.5		11	12	14	8	10	8	10	8	2	3	4
67.7		11	10	14	8	9	8	9	7	3	3	2
67.8		10	11	14	8	9	8	9	8	4	3	2
67.9		12	11	14	9	9	8	10	8	4	3	2
67.10	10.4	11	10	16	8	10	8	10	8	4	3	5
68.1	11.3	12	8	16	6	8	6	10	6	2	2	1
68.2		11	9	14	8	8	8	9	7	2	2	-4
68.3		12	10	14	9	9	8	9	7	2	2	2
68.4		12	11	16	8	10	8	11	8	5	4	2
68.5		12	10	16	8	10	9	10	9	6	4	3
68.6		-8	-8	-12	-8	-10	-7	-8	-6	-9	-6	-2
69.1		9	6	11	5	6	5	6	5	-6	1	-2
69.2		10	8	12	6	5	5	8	6	-9	0	0
69.3	9.7	10	9	12	5	6	5	6	4	0	0	0
69.4	9.7	10	9	12	7	8	8	8	6	2	2	2
69.5	11.3	11	9	13	6	6	6	8	6	2	2	1
69.6		-9	-8	-11	-8	-10	-7	-6	-6	-13	-8	-7
69.7		-10	-8	-11	-8	-10	-8	-6	-6	-10	-12	-14
69.8		-8	-8	-10	-8	-9	-7	-6	-13	-16	-16	>-20

TABLE V
c. Load Bank Voltages

Run Number	Time, T ₂ , sec	Load Bank Voltage, v								
		R1	R2	R3	R4	R _{center}		R34	R35	R36
		Element 1 Element 2, V ₂	Element 2 Element 3, V ₄	Element 3 Element 4, V ₆	Element 4 Element 5, V ₈	Element 5 Element 57, V ₆₂	Element 3 Element 58, V ₆₂	Element 57 Element 58, V ₅₄	Element 56 Element 59, V ₅₆	Element 59 Element 60 V ₅₈
59.2	13.9	0	4	4	6	320	---	5	3	1
59.3	14.5	0	4	4	6	350	---	5	4	1
59.4	14.3	0	3	4	6	340	---	5	4	0
59.5	13.9	0	4	4	6	330	---	5	4	1
59.6	14.3	0	4	4	6	330	---	5	4	0
60.1	12.3	0	2	2	4	350	---	4	3	0
61.2	12.3	0	2	2	4	310	---	4	3	0
61.3	12.5	0	3	3	4	390	---	4	2	0
61.4	12.3	0	2	2	4	350	---	4	2	0
61.5	11.9	0	3	4	6	260	---	5	3	0
61.7	12.7	0	3	4	6	270	---	5	4	0
62.1	12.3	0	3	4	6	260	---	4	3	0
62.2	12.1	0	4	4	6	280	---	5	3	0
62.3	12.3	0	4	4	6	280	---	6	3	1
62.4	12.5	0	4	4	6	230	---	6	4	1
62.5	12.3	0	4	4	7	230	---	6	4	1
63.1	12.7	0	4	4	7	150	---	6	4	1
63.2	12.1	0	4	5	7	160	---	6	4	1
63.3	12.1	0	5	6	8	70	---	8	4	2
63.4	12.3	0	5	6	8	70	---	8	4	2
63.5	12.1	0	5	6	9	0	---	8	4	2
63.6	12.5	0	6	6	10	0	---	8	5	1
64.1	11.5	---	---	---	---	---	255	---	---	---
64.2	11.5	---	---	---	---	---	270	---	---	---
64.3	11.5	---	---	---	---	---	260	---	---	---
65.6	8.9	---	---	---	---	---	180	---	---	---
66.1	11.3	---	---	---	---	---	180	---	---	---
66.2	11.3	---	---	---	---	---	200	---	---	---

TABLE V
c. Concluded

Run Number	Time, T ₂ , sec	Load Bank Voltage, v								
		R1	R2	R3	R4	R _{center}	R34	R35	R36	
		Element 1 Element 2, V ₂	Element 2 Element 3, V ₄	Element 3 Element 4, V ₆	Element 4 Element 5, V ₈	Element 5 Element 57, V ₆₂	Element 3 Element 58, V ₆₂	Element 57 Element 58, V ₅₄	Element 58 Element 59, V ₅₆	Element 59 Element 60, V ₅₈
66.3	11.3	---	---	---	---	---	220	---	---	---
66.4		---	---	---	---	---	130	---	---	---
66.5		---	---	---	---	---	140	---	---	---
66.6		---	---	---	---	---	60	---	---	---
66.7		---	---	---	---	---	65	---	---	---
66.8		---	---	---	---	---	0	---	---	---
66.9		---	---	---	---	---	0	---	---	---
66.10		---	---	---	---	---	250	---	---	---
66.11		---	---	---	---	---	265	---	---	---
67.1	11.5	---	---	---	---	---	240	---	---	---
67.2	11.3	---	---	---	---	---	265	---	---	---
67.3		---	---	---	---	---	280	---	---	---
67.5		---	---	---	---	---	285	---	---	---
67.7		---	---	---	---	---	320	---	---	---
67.8		---	---	---	---	---	300	---	---	---
67.9		---	---	---	---	---	330	---	---	---
67.10	10.4	---	---	---	---	---	320	---	---	---
68.1	11.3	---	---	---	---	---	160	---	---	---
68.2		---	---	---	---	---	180	---	---	---
68.3		---	---	---	---	---	190	---	---	---
68.4		---	---	---	---	---	320	---	---	---
68.5		---	---	---	---	---	290	---	---	---
68.6		---	---	---	---	---	190	---	---	---
69.1		---	---	---	---	---	0	---	---	---
69.2		---	---	---	---	---	0	---	---	---
69.3	9.7	---	---	---	---	---	0	---	---	---
69.4	9.7	---	---	---	---	---	180	---	---	---
69.5	11.3	---	---	---	---	---	225	---	---	---
69.6		---	---	---	---	---	240	---	---	---
69.7		---	---	---	---	---	180	---	---	---
69.8		---	---	---	---	---	0	---	---	---

DOCUMENT CONTROL DATA - R & D

(Security classification of title, body of abstract and indexing annotation must be entered when the overall report is classified)

1. ORIGINATING ACTIVITY (Corporate author) Arnold Engineering Development Center ARO, Inc., Operating Contractor Arnold Air Force Station, Tennessee		2a. REPORT SECURITY CLASSIFICATION UNCLASSIFIED	
		2b. GROUP N/A	
3. REPORT TITLE EXPERIMENTAL PERFORMANCE OF A HALL MAGNETOHYDRODYNAMIC ELECTRIC POWER GENERATOR			
4. DESCRIPTIVE NOTES (Type of report and Inclusive dates) Final Report February 28 to May 24, 1967			
5. AUTHOR(S) (First name, middle initial, last name) R. J. LeBoeuf and J. D. McNeese, ARO, Inc.			
6. REPORT DATE December 1967	7a. TOTAL NO. OF PAGES 66	7b. NO. OF REFS 4	
8a. CONTRACT OR GRANT NO. AF 40(600)-1200	8a. ORIGINATOR'S REPORT NUMBER(S) AEDC-TR-67-250		
b. PROJECT NO. 5350	8b. OTHER REPORT NO(S) (Any other numbers that may be assigned this report) N/A		
c. Program Element 62405214			
d. Task 535004			
10. DISTRIBUTION STATEMENT Subject to special export controls; transmittal to foreign governments or foreign nationals requires approval of Air Force Aero-Propulsion Laboratory (APIE-2), Wright-Patterson AFB, Ohio.			
11. SUPPLEMENTARY NOTES Available in DDC. Contract AF 33(615)-2691 with UTSI		12. SPONSORING MILITARY ACTIVITY Air Force Aero-Propulsion Laboratory (APIE-2), Wright- Patterson AFB, Ohio 45433	
13. ABSTRACT A test program was conducted on a Hall Magnetohydrodynamic generator. The internal dimensions of the generator channel diverged from 4 in. in height at the channel inlet to 6 in. in height at the channel exit, and the width was 2 in. along the 48-in. length of the channel. The plasma was provided by a gaseous oxygen/RP-1 combustor with a Mach number 1.6 nozzle. The propellants were seeded with potassium hydroxide (KOH) dissolved in ethyl alcohol to produce a high ion concentration in the exhaust stream. The generated power was dissipated through a resistor load bank with a variety of parallel and series resistance configurations. Operating conditions were nominally as follows: combustor chamber pressure, 46 psia; KOH concentration, 1.3 percent of total propellant weight flow, magnetic field, 20,000 gauss; and load bank resistance, from 0 to 24.9 ohms. Tabulations of combustor performance data and of the generator electrical data are presented. This document is subject to special export controls and each transmittal to foreign governments or foreign nationals may be made only with prior approval of Air Force Aero-Propulsion Laboratory (APIE-2), Wright-Patterson AFB, Ohio.			

14.

KEY WORDS

LINK A

LINK B

LINK C

ROLE

WT

ROLE

WT

ROLE

WT

magnetohydrodynamics
generators, electric power
experimental performance