

UNCLASSIFIED

AD NUMBER

AD824245

LIMITATION CHANGES

TO:

Approved for public release; distribution is unlimited.

FROM:

Distribution authorized to U.S. Gov't. agencies and their contractors; Critical Technology; DEC 1967. Other requests shall be referred to Arnold Engineering Development Center, Arnold Air Force Station, TN 37389. This document contains export-controlled technical data.

AUTHORITY

AFFDL ltr, 20 Dec 1974

THIS PAGE IS UNCLASSIFIED

AEDC-TR-67-260

*cy,*

**ARCHIVE COPY  
DO NOT LOAN**



**DRAG AND PERFORMANCE CHARACTERISTICS OF  
FLEXIBLE AERODYNAMIC DECELERATORS IN  
THE WAKES OF DOUBLE-STRUT MOUNTED FOREBODIES  
AT MACH NUMBERS FROM 2 TO 5**

A. W. Myers

ARO, Inc.

*PROPERTY OF  
AF 40(600)1200  
W 21500-260*

**December 1967**

*This document is not for public release  
its distribution is unlimited.*

*PER THIS 74-26, 74  
Dtd 20 Dec, 74*

This document is subject to special export controls and each transmittal to foreign governments or foreign nationals may be made only with prior approval of Air Force Flight Dynamics Laboratory (FDFR), Wright-Patterson AFB, Ohio.

**VON KÁRMÁN GAS DYNAMICS FACILITY  
ARNOLD ENGINEERING DEVELOPMENT CENTER  
AIR FORCE SYSTEMS COMMAND  
ARNOLD AIR FORCE STATION, TENNESSEE**

PROPERTY OF U. S. AIR FORCE  
AEDC LIBRARY  
AF 40(600)1200

AEDC TECHNICAL LIBRARY



5 0720 00031 6406

# ***NOTICES***

When U. S. Government drawings specifications, or other data are used for any purpose other than a definitely related Government procurement operation, the Government thereby incurs no responsibility nor any obligation whatsoever, and the fact that the Government may have formulated, furnished, or in any way supplied the said drawings, specifications, or other data, is not to be regarded by implication or otherwise, or in any manner licensing the holder or any other person or corporation, or conveying any rights or permission to manufacture, use, or sell any patented invention that may in any way be related thereto.

Qualified users may obtain copies of this report from the Defense Documentation Center.

References to named commercial products in this report are not to be considered in any sense as an endorsement of the product by the United States Air Force or the Government.

DRAG AND PERFORMANCE CHARACTERISTICS OF  
FLEXIBLE AERODYNAMIC DECELERATORS IN  
THE WAKES OF DOUBLE-STRUT MOUNTED FOREBODIES  
AT MACH NUMBERS FROM 2 TO 5

A. W. Myers

ARO, Inc.

This document is subject to special export controls and each transmittal to foreign governments or foreign nationals may be made only with prior approval of Air Force Flight Dynamics Laboratory (FFDL), Wright-Patterson AFB, Ohio.

This document has been approved for public release

its distribution is unlimited.

*PER 7/13/74 26  
Df 20 Dec, 74*

## FOREWORD

The work reported herein was done at the request of the Air Force Flight Dynamics Laboratory (AFFDL) (FDFR), Air Force Systems Command (AFSC), for the Goodyear Aerospace Corporation, Akron, Ohio, under Program Element 6240533F, Project 6065, Task 606507.

The results of tests presented were obtained by ARO, Inc. (a subsidiary of Sverdrup & Parcel and Associates, Inc.), contract operator of the Arnold Engineering Development Center (AEDC), AFSC, Arnold Air Force Station, Tennessee, under Contract AF40(600)-1200. The tests were conducted from September 12 to 16, 1967, under ARO Project No. VT0626, and the manuscript was submitted for publication on November 6, 1967.

Information in this report is embargoed under the Department of State International Traffic in Arms Regulations. This report may be released to foreign governments by departments or agencies of the U. S. Government subject to approval of the Air Force Flight Dynamics Laboratory (FDFR), Wright-Patterson AFB, Ohio, or higher authority within the Department of the Air Force. Private individuals or firms require a Department of State export license.

This technical report has been reviewed and is approved.

Donald H. Meyer  
Major, USAF  
AF Representative, VKF  
Directorate of Test

Leonard T. Glaser  
Colonel, USAF  
Director of Test

**ABSTRACT**

Tests were conducted in the 40-in. supersonic tunnel of the von Kármán Gas Dynamics Facility to determine the drag and stability characteristics of a series of flexible supersonic decelerator models deployed at various positions aft of two double-strut mounted forebodies and to define the centerline wake flow characteristics of one of the forebodies. Data were obtained at Mach numbers from 2 to 5 at dynamic pressures corresponding to pressure altitudes which ranged from 82,000 to 142,000 ft. Selected typical results are presented.

This document is subject to special export controls and each transmittal to foreign governments or foreign nationals may be made only with prior approval of Air Force Flight Dynamics Laboratory (FFDL), Wright-Patterson AFB, Ohio.

This document has been approved for public release  
its distribution is unlimited. *PER TAB 74-26*  
*DtJ 20 Dec, 74*

## CONTENTS

	<u>Page</u>
ABSTRACT . . . . .	iii
NOMENCLATURE . . . . .	vi
I. INTRODUCTION . . . . .	1
II. APPARATUS . . . . .	
2.1 Wind Tunnel . . . . .	1
2.2 Test Articles . . . . .	2
2.3 Instrumentation . . . . .	2
III. DECELERATOR TEST PROCEDURE . . . . .	3
IV. RESULTS AND DISCUSSION . . . . .	
4.1 Parachute Drag and Centerline Wake Characteristics . . . . .	3
4.2 Parachute Performance . . . . .	4

## TABLE

I. Summary of Parachute Test Conditions and Performance Results . . . . .	5
--	---

APPENDIX  
IllustrationsFigure

1. Forebody and Strut Support Details . . . . .	
a. Forebody Details . . . . .	9
b. Strut Details . . . . .	10
c. Tunnel Installation Sketch . . . . .	10
2. Decelerator Design and Construction Parameters . . . . .	
a. Parasonic Parachute Construction . . . . .	11
b. Design Details . . . . .	11
c. Configuration 1 in Tunnel A, $M_\infty = 4$ , $q_\infty = 1.0$ psia . . . . .	12
d. Configuration Photographs . . . . .	12
3. Wake Survey Probe Details . . . . .	13
4. Effect of Canopy Design, Location in the Wake, and Mach Number on the Drag of Parachutes behind Forebody Configuration 2, $q_\infty = 1.0$ psia . . . . .	14
5. Effect of Canopy Design, Location in the Wake, and Mach Number on the Drag of Parachutes behind Forebody Configuration 3, $q_\infty = 0.5$ psia . . . . .	15
6. Wake Centerline Characteristics of Forebody Configuration 2, $q_\infty = 1.0$ psia. . . . .	16

## NOMENCLATURE

a, b, c	Parachute canopy grid dimensions, in.
$C_{DP}$	Drag coefficient of parachute canopy based on projected canopy area, drag force/ $q_{\infty} S_p$
$D_i$	Parachute canopy inlet diameter, in.
$D_p$	Parachute canopy projected diameter, in.
$D_r$	Parachute canopy roof cap diameter, in.
d	Forebody base diameter, in.
f	Parachute canopy reinforcement web thickness, in.
$l$	Parachute canopy skirt length, in.
$l_s$	Parachute suspension line length, in.
$M_L$	Wake local Mach number
$M_{\infty}$	Free-stream Mach number
m	Canopy surface dimension, in.
$q_L$	Wake local dynamic pressure, psia
$q_{\infty}$	Free-stream dynamic pressure, psia
$S_p$	Design projected area of inflated parachute canopy, in.
v, w	Parachute suspension line cross-sectional dimensions, in.
x	Distance from the base of the forebody model to the parachute canopy inlet, in.
$\lambda_t$	Total parachute canopy porosity, percent

## SECTION I INTRODUCTION

Tests were conducted in the 40-in. supersonic tunnel (Gas Dynamic Wind Tunnel, Supersonic (A)) of the von Kármán Gas Dynamics Facility (VKF) to verify, through the use of an improved drag measuring system, the drag and stability characteristics reported by Myers and Hahn<sup>1</sup> for a series of flexible supersonic decelerator models at various positions aft of two double-strut mounted forebodies and to determine the centerline wake flow characteristics of one of the forebodies. The two forebodies were the Arapaho "C" test vehicle and a blunted elliptical cone model, and the decelerators were "Parasonics", members of the hyperflo family of high performance, supersonic parachutes. The tests were conducted at Mach numbers from 2 to 5 at dynamic pressures corresponding to pressure altitudes which ranged from 82, 000 to 142, 000 ft.

Selected typical results are presented showing the centerline wake characteristics of the Arapaho "C" forebody model and the effects of Mach number, location in the wake, and design parameters on the parachute drag. The parachute performance and stability (stability as discussed in this report refers only to the conditions of oscillatory motion of the parachute with respect to the forebody) are summarized for each test condition.

## SECTION II APPARATUS

### 2.1 WIND TUNNEL

Tunnel A is a continuous, closed-circuit, variable density wind tunnel with an automatically driven, flexible-plate-type nozzle and a 40- by 40-in. test section. The tunnel operates at Mach numbers from 1.5 to 6 at maximum stagnation pressures from 29 to 200 psia, respectively, and stagnation temperatures up to 300°F ( $M_\infty = 6$ ). Minimum pressures

---

<sup>1</sup>Myers, A. W. and Hahn, J. S. "Drag and Performance Characteristics of Flexible Aerodynamic Decelerators in the Wake of Basic and Modified Arapaho "C" Test Vehicle Configurations at Mach Numbers from 2 to 5." AEDC-TR-67-75 (AD 813808), May 1967.

range from about one-tenth to one-twentieth of the maximum pressures. A description of the tunnel and airflow calibration information may be found in the Test Facilities Handbook<sup>2</sup>.

## 2.2 TEST ARTICLES

### 2.2.1 Forebodies and Support System

The forebodies employed for the tests are shown in Fig. 1 (Appendix). The 0.182-scale model of the Arapaho "C" (configuration 2) consisted of a blunted cone nose, cylindrical centerbody, and flared afterbody. Configuration 3 consisted of a blunted, elliptical cone with a nose shape identical to configuration 2.

The forebody support system (Fig. 1b) consisted of a strut spanning the width of the tunnel and mounted to the sidewalls. The drag tensiometer and a winch assembly for varying the location of the decelerator aft of the forebody were housed in a vacuum tank, which was also mounted to the tunnel sidewall (Fig. 1b). The decelerator support line passed through the model and strut and into the vacuum tank when it was attached to the tensiometer and winch assembly.

### 2.2.2 Decelerator Models

Design and construction details of the four parasonic parachutes, which are constructed in the shape assumed by an inflated hyperflo parachute (hyperflo parachutes are constructed as truncated cones) with porous and low porosity skirts, are given in Fig. 2. Construction variables investigated were canopy size and roof grid size. Constant total porosity ( $\lambda_t$ ) of 5 percent was maintained for all parachutes by careful application to the roofs of a flexible, thermal coating. Canopy location ( $x/d$ ) behind the forebodies was varied from 5 to 7.

## 2.3 INSTRUMENTATION

Parachute drag measurements were made with a 60-lb tensiometer located in the winch assembly and calibrated for ranges of 30 and 60 lb. Average drag values were monitored with a low response servopotentiometer, and a time history of the dynamic output from the tensiometer

---

<sup>2</sup>Test Facilities Handbook (6th Edition). "von Kármán Gas Dynamics Facility, Vol. 4." Arnold Engineering Development Center, November 1966.

was recorded on an oscillograph. The accuracy of the drag measuring system, determined from repeated static loads applied before the test, is shown below.

<u>Load Range, lb</u>	<u>Error, lb</u>
0 to 5	$\pm 0.15$
6 to 15	$\pm 0.25$
16 to 30	$\pm 0.33$
31 to 60	$\pm 0.84$

Parachute performance was monitored on two high-speed, 16-mm motion-picture cameras (one for side motion pictures and one for schlieren photography), and additional photographic results were obtained with still cameras mounted in the schlieren system and next to the test section windows.

Local wake centerline pitot and static pressures and total temperature were measured with single, low interference probes mounted to an axial probe drive mechanism (Fig. 3). The measured static and pitot pressures were then used to calculate the local Mach number and dynamic pressure. The accuracy of the calculated Mach number is estimated to be within  $\pm 0.10$ .

### SECTION III DECCELERATOR TEST PROCEDURE

Before each test run, the parachute canopy and suspension lines were packed in a deployment bag, which was then suspended near the base of the forebody model by a pull cord routed from the rear of the bag through the tunnel sector. The pull cord was held taut during tunnel start, and when the desired test condition was established, a sharp pull on the cord removed the bag. Parachute location behind the forebody was set by the remotely operated winch assembly using reference marks placed on the tunnel windows.

### SECTION IV RESULTS AND DISCUSSION

#### 4.1 PARACHUTE DRAG AND CENTERLINE WAKE CHARACTERISTICS

The average drag coefficients of parachutes behind forebody configuration 2 are presented in Fig. 4. The drag of parachute configuration 1 (small mesh canopy) was higher for all test conditions than the

drag of parachute configuration 2 (large mesh canopy), although the variation between the two was small for  $M_\infty > 2$ . The data from the present test and those reported by Myers and Hahn<sup>3</sup> (solid symbols) show the same trends with  $x/d$ , and except for  $M_\infty = 2$  the present drag values are somewhat higher than the previous measurements.

The variation of the drag coefficients of the larger diameter parachutes (configurations 3 and 4) behind forebody 3 is presented in Fig. 5. Unlike the small diameter parachutes behind forebody 2 (Fig. 4), increasing the canopy mesh size of the large diameter parachutes (behind forebody 3) had little effect on the parachute drag for  $M_\infty < 3$  and increased the drag for  $M_\infty = 4$  and 5.

The variation of the local Mach number and dynamic pressure on the centerline of the wake of forebody 2 is presented in Fig. 6. Both the local Mach number and dynamic pressure increased as  $x/d$  increased, until at  $x/d = 10$ , these parameters were 78 and 65 percent, respectively, of the free-stream value at  $M_\infty = 2$  and 66 and 43 percent of the free-stream value at  $M_\infty = 5$ . The sonic point location ( $M_L = 1$ ) decreased from  $x/d \approx 3.2$  at  $M_\infty = 2$  to  $x/d < 1.0$  at  $M_\infty = 4$  and 5.

## 4.2 PARACHUTE PERFORMANCE

The performance of the parachutes for each test condition is summarized in Table I. The inflation characteristics of the parachutes were generally good for the  $x/d$  range investigated. The stability of the smaller diameter parachutes behind forebody 2 increased with Mach number and was independent of canopy mesh size. The stability of the large diameter parachutes behind forebody 3 was either independent of Mach number (small mesh canopy) or increased as Mach number decreased (large mesh canopy). The observations presented in the table are the results of evaluations of the photographic data. Earlier reports by the author present supplementary information on the performance of parachutes and forebodies<sup>4, 5, 6</sup>.

---

<sup>3</sup>Ibid, p. 1.

<sup>4</sup>Myers, A. W. "Aerodynamic Characteristics of Basic and Modified Arapaho "C" Test Vehicle Configurations at Mach Numbers from 2.5 to 5." AEDC-TR-66-229, December 1966.

<sup>5</sup>Ward, L. K., and Myers, A. W. "Free-Flight Testing of Aerodynamic Decelerators in a Supersonic Wind Tunnel." AEDC-TR-67-93 (AD815090), June 1967.

<sup>6</sup>Myers, A. W. "Drag and Performance Characteristics of Flexible Supersonic Decelerator Models at Mach Numbers from 2 to 6." AEDC-TR-67-224, November 1967.

**TABLE I**  
**SUMMARY OF PARACHUTE TEST CONDITIONS AND PERFORMANCE RESULTS**

Parachute Configuration	Forebody Configuration	$M_\infty$	$x/d$		$q_\infty$ , psia	$C_{DP}$		Remarks
			Min	Max		Min	Max	
1	2	2	5	7	1.0	0.85	1.04	Canopy inflation good at all $x/d$ . Light to medium canopy pumping at $x/d = 5$ increasing to medium to heavy at $x/d = 6$ and 7. Stable to unstable at all $x/d$ .
						0.45	0.57	
						0.34	0.42	
						0.34	0.38	
						0.61	0.88	
2	2	2	5	7	1.0	0.44	0.47	Inflation same as $M_\infty = 2$ . Canopy motionless at $x/d = 5$ with light pumping at $x/d = 6$ and 7. Very stable at $x/d = 5$ and 6, stable to unstable at $x/d = 7$ .
						0.31	0.38	
						0.27	0.30	
						0.70	0.79	
3	4	2	5	7	1.0	0.87	1.01	Same as $M_\infty = 2$ except very stable to stable at $x/d = 7$ .
						0.30	0.47	
						0.13	0.27	
						0.70	0.79	
4	2	2	5	7	1.0	0.92	1.04	Good inflation at all $x/d$ . Canopy motionless at $x/d = 5$ , with light to medium pumping at $x/d = 6$ and 7. Very stable at all $x/d$ .
						0.62	0.80	
						0.34	0.55	
						0.23	0.38	
						0.70	0.79	

Note: The following nomenclature is used in discussing parachute stability:

- Very stable - Oscillations less than  $\pm 2$  deg
- Stable - Oscillations between  $\pm 2$  and 5 deg
- Unstable - Oscillations greater than  $\pm 5$  deg

**APPENDIX  
ILLUSTRATIONS**

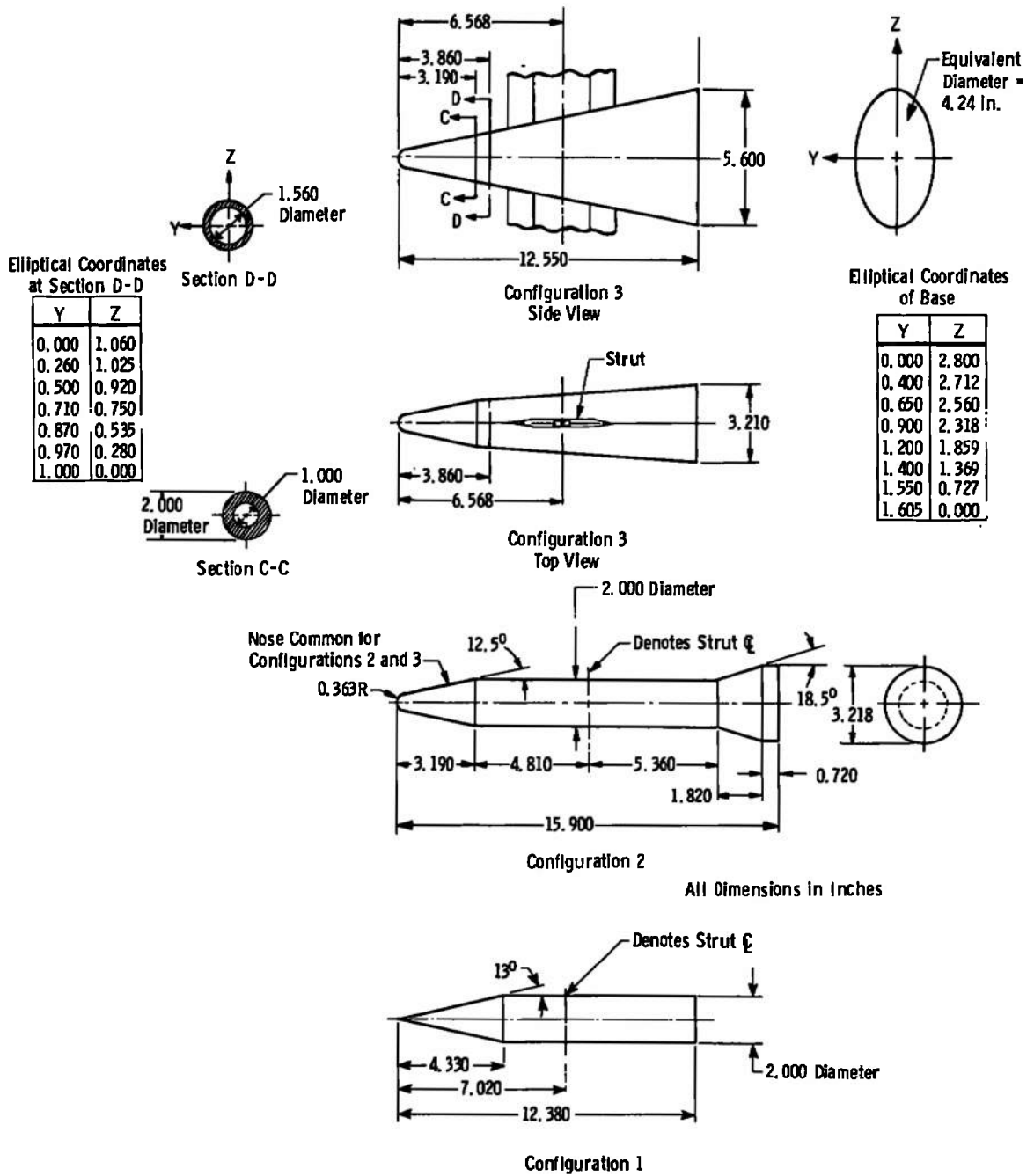

a. Forebody Details  
 Fig. 1 Forebody and Strut Support Details

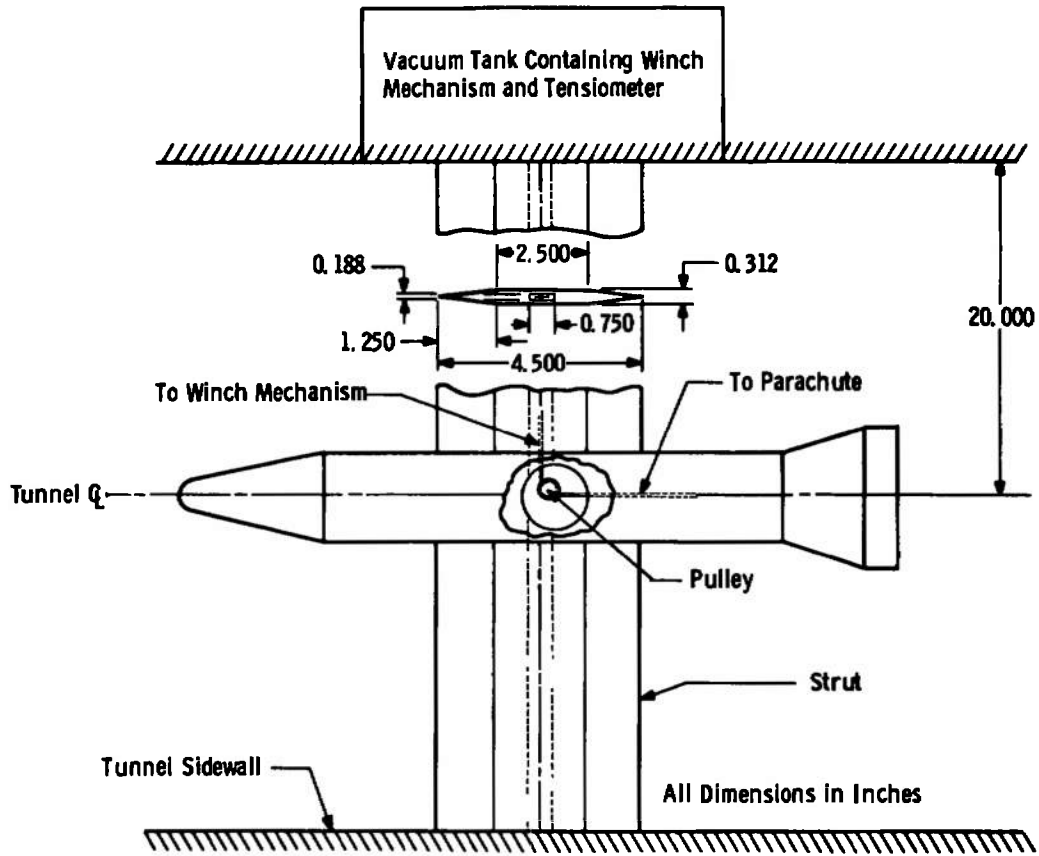

b. Strut Details

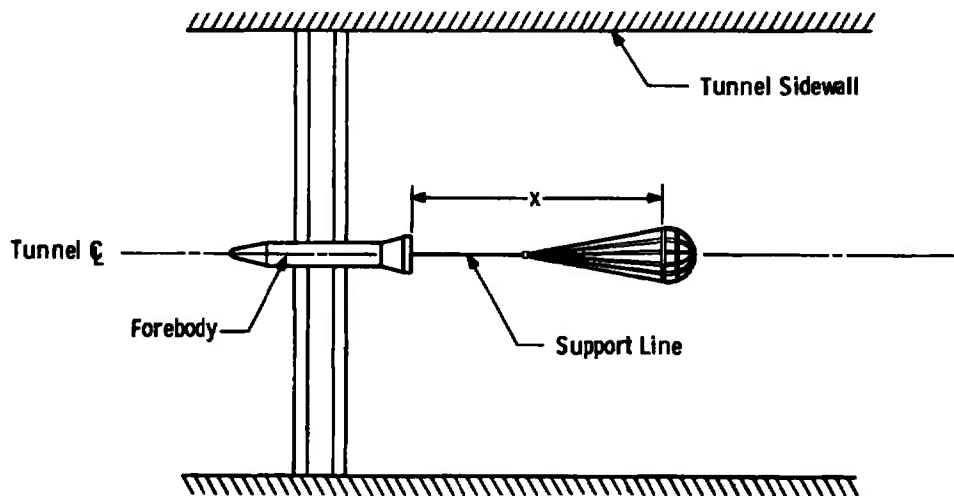

c. Tunnel Installation Sketch

Fig. 1 Concluded



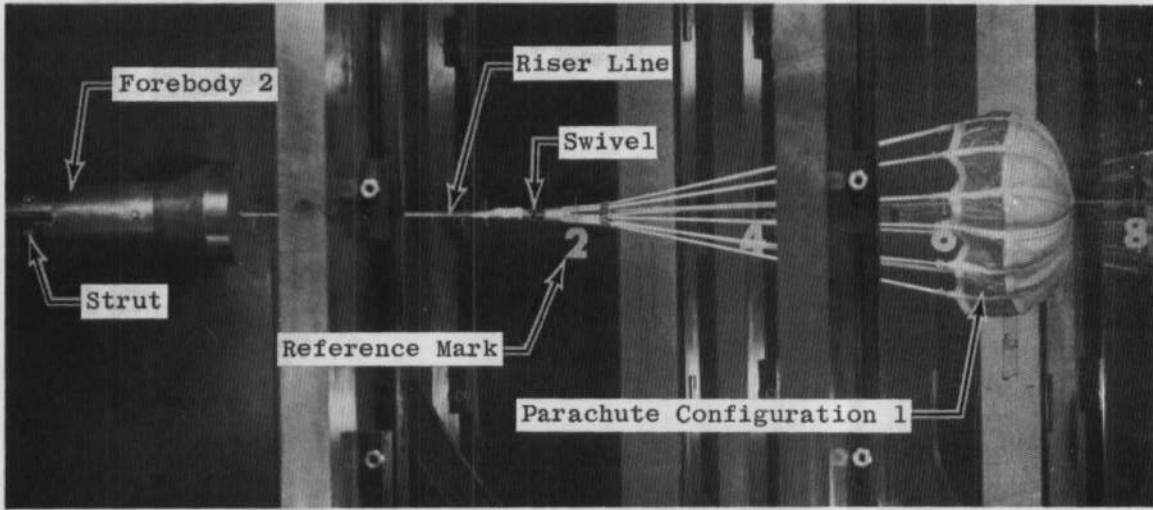

c. Configuration 1 in Tunnel A,  $M_\infty = 4$ ,  $q_\infty = 1.0$  psio

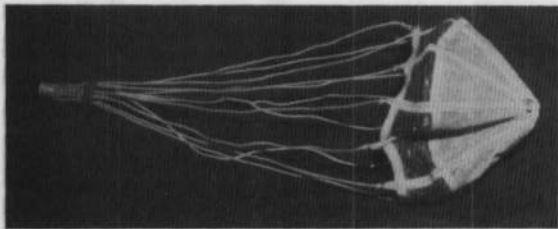

Parachute Configuration 1

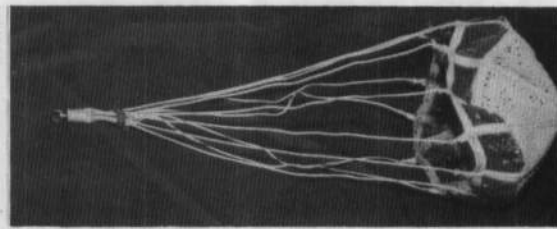

Parachute Configuration 2

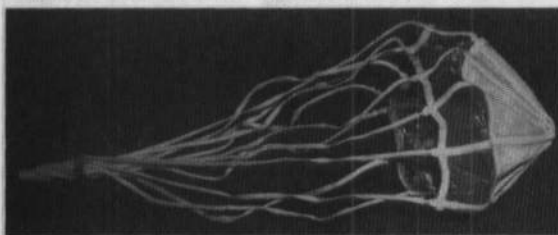

Parachute Configuration 3

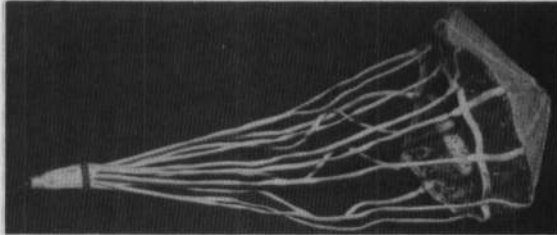

Parachute Configuration 4

d. Configuration Photographs  
Fig. 2 Concluded

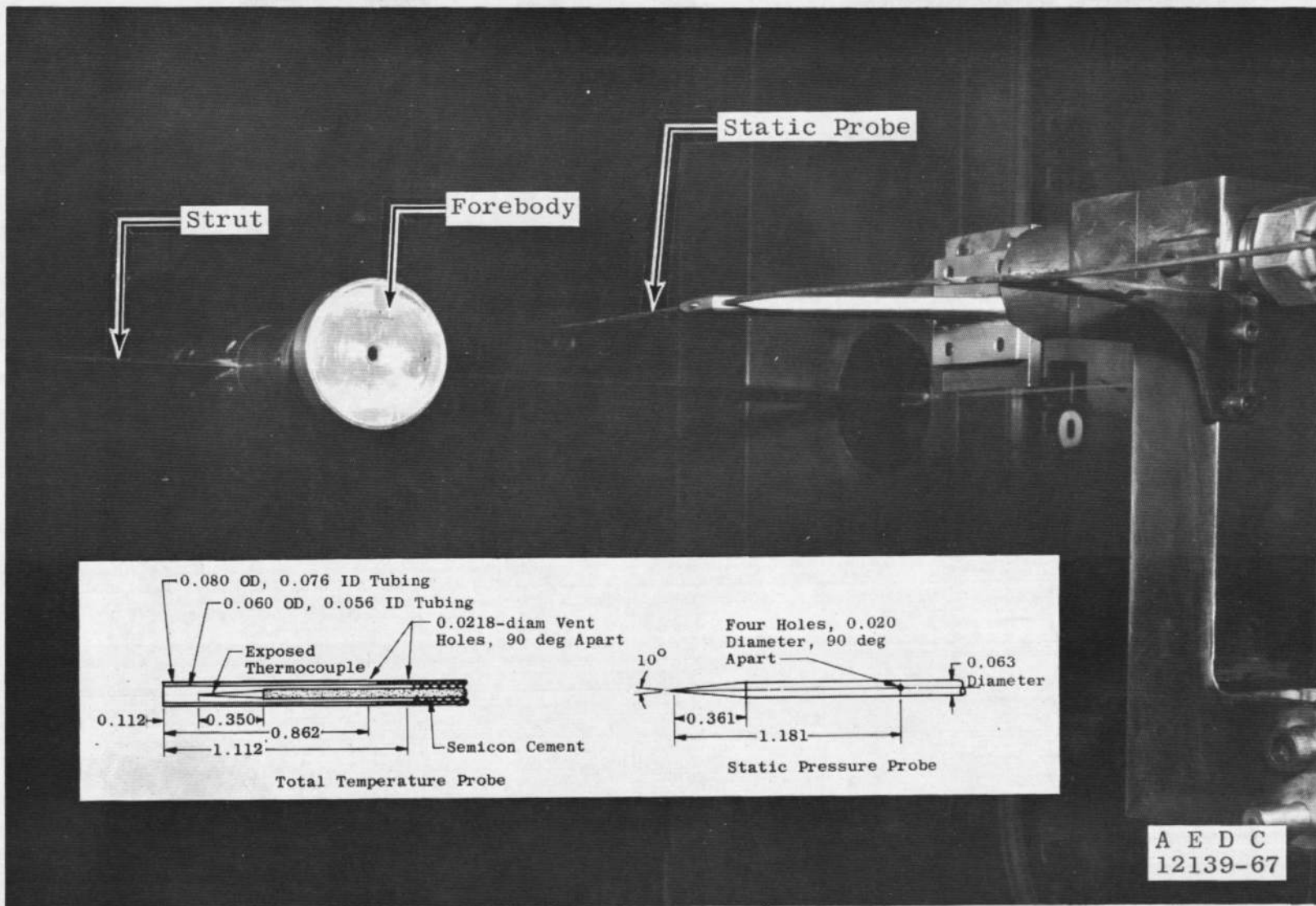

Fig. 3 Wake Survey Probe Details

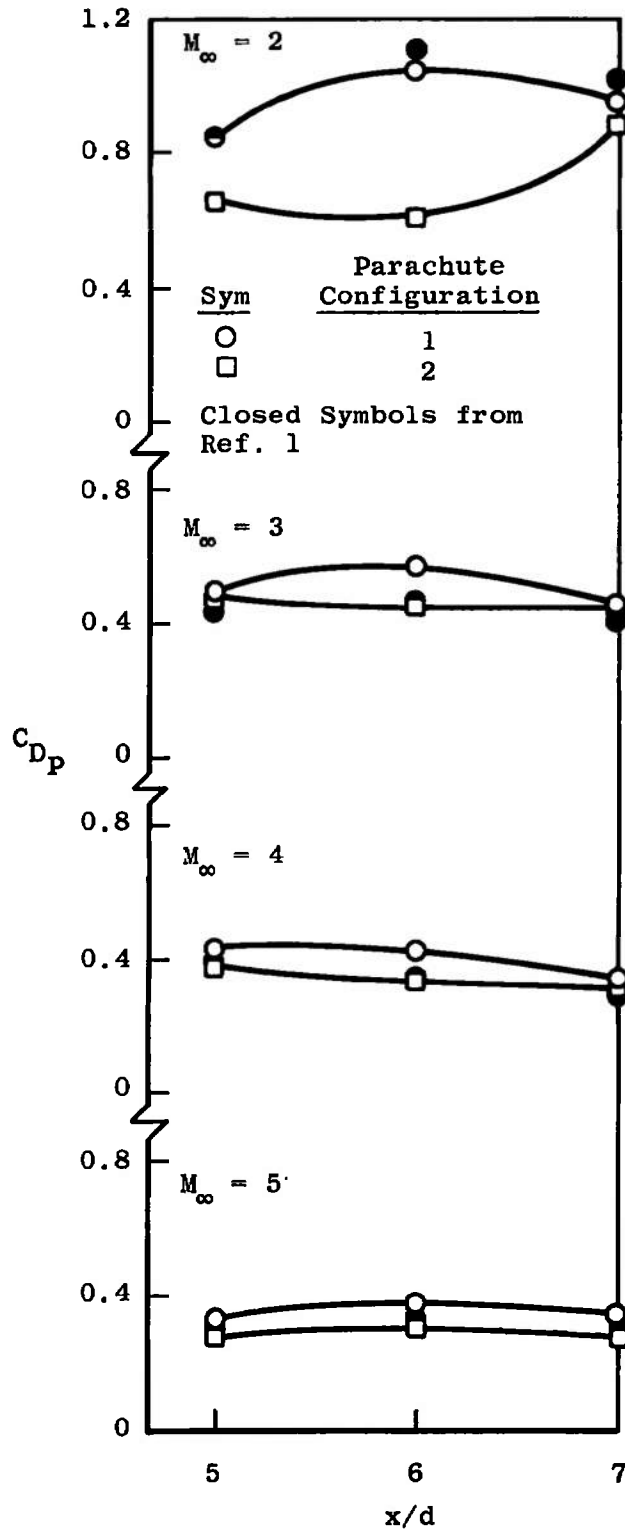

Fig. 4 Effect of Conopy Design, Location in the Wake, and Mach Number on the Drag of Parachutes behind Forebody Configuration 2,  $q_\infty = 1.0$  psio

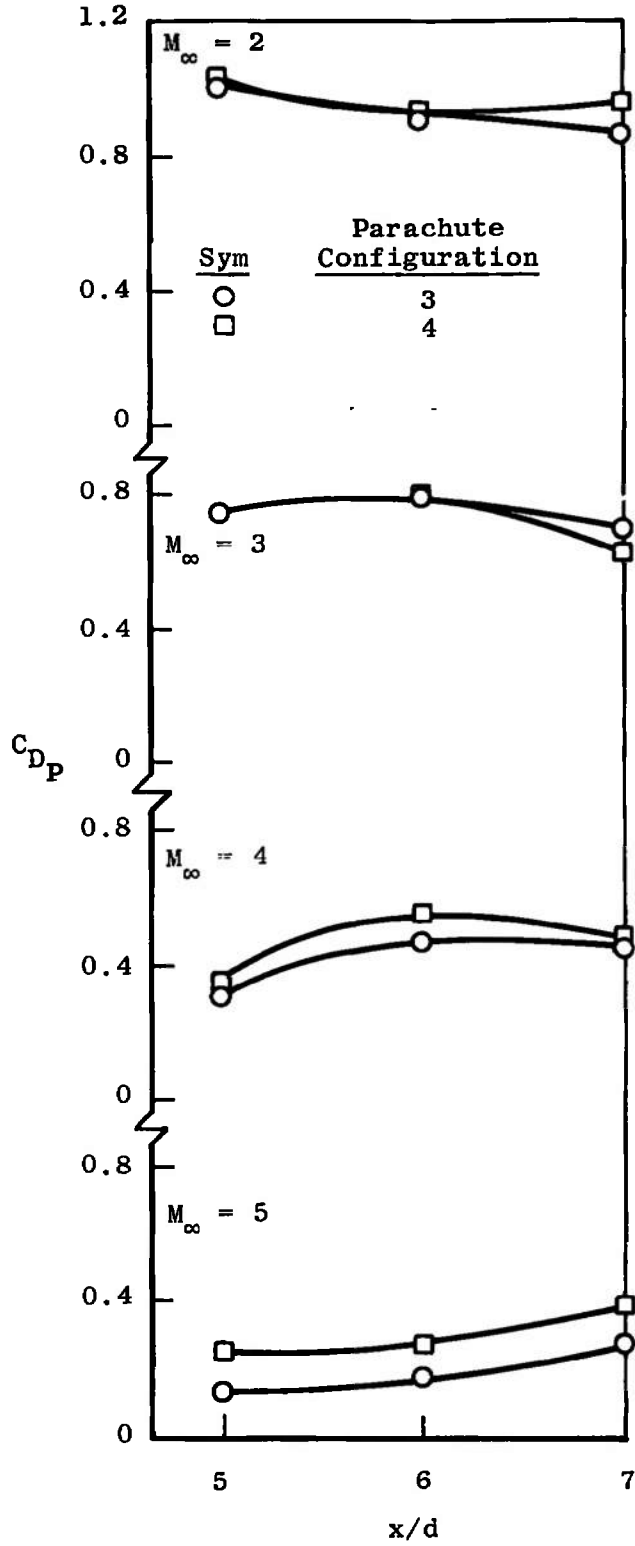

Fig. 5 Effect of Canopy Design, Location in the Wake, and Mach Number on the Drag of Parachutes behind Forebody Configuration 3,  $q_{oc} = 0.5$  psia

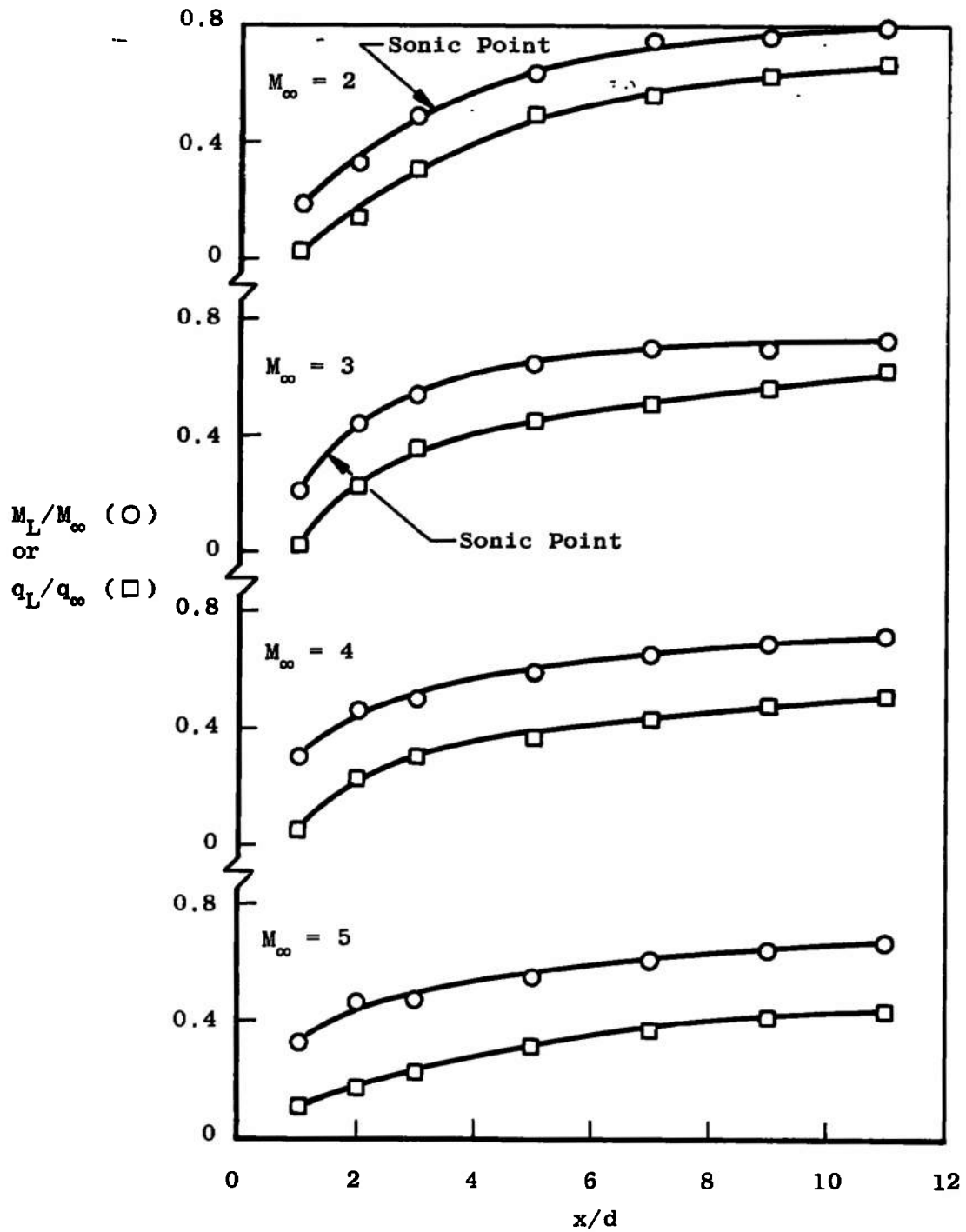

Fig. 6 Wake Centerline Characteristics of Forebody Configuration 2,  $q_\infty = 1.0$  psia

DOCUMENT CONTROL DATA - R & D

(Security classification of title, body of abstract and indexing annotation must be entered when the overall report is classified)

1. ORIGINATING ACTIVITY (Corporate author) Arnold Engineering Development Center, ARO, Inc., Operating Contractor, Arnold Air Force Station, Tennessee		2a. REPORT SECURITY CLASSIFICATION UNCLASSIFIED	
		2b. GROUP N/A	
3. REPORT TITLE DRAG AND PERFORMANCE CHARACTERISTICS OF FLEXIBLE AERODYNAMIC DECELERATORS IN THE WAKES OF DOUBLE-STRUT MOUNTED FOREBODIES AT MACH NUMBERS FROM 2 TO 5			
4. DESCRIPTIVE NOTES (Type of report and inclusive dates) September 12 to 16, 1967 - Final Report			
5. AUTHOR(S) (First name, middle initial, last name) A. W. Myers, ARO, Inc.			
6. REPORT DATE December 1967		7a. TOTAL NO. OF PAGES 22	7b. NO. OF REFS 5
8a. CONTRACT OR GRANT NO. AF40(600)-1200		9a. ORIGINATOR'S REPORT NUMBER(S) AEDC-TR-67-260	
b. PROJECT NO. 6065		9b. OTHER REPORT NO(S) (Any other numbers that may be assigned this report) N/A	
c. Program Element 6240533F			
d. Task 606507			
10. DISTRIBUTION STATEMENT This document is subject to special export controls and each transmittal to foreign governments or foreign nationals may be made only with prior approval of Air Force Flight Dynamics Laboratory (EDFR), Wright-Patterson AFB, Ohio.			
11. SUPPLEMENTARY NOTES Available in DDC.		12. SPONSORING MILITARY ACTIVITY Air Force Flight Dynamics Laboratory (EDFR), Wright-Patterson AFB, Ohio	
13. ABSTRACT Tests were conducted in the 40-in. supersonic tunnel of the von Kármán Gas Dynamics Facility to determine the drag and stability characteristics of a series of flexible supersonic decelerator models deployed at various positions aft of two double-strut mounted forebodies and to define the centerline wake flow characteristics of one of the forebodies. Data were obtained at Mach numbers from 2 to 5 at dynamic pressures corresponding to pressure altitudes which ranged from 82,000 to 142,000 ft. Selected typical results are presented.  This document is subject to special export controls and each transmittal to foreign governments or foreign nationals may be made only with prior approval of Air Force Flight Dynamics Laboratory (EDFR), Wright-Patterson AFB, Ohio.			

This document has been approved for public release  
its distribution is unlimited. PER TAB 1426  
Dtd 20 Dec, 74

14. KEY WORDS	LINK A		LINK B		LINK C	
	ROLE	WT	ROLE	WT	ROLE	WT
aerodynamic configurations flexible decelerators performance forebodies double-strut mounted supersonic flow  2. Parachutes - <i>Parform</i>  1-15.						