

UNCLASSIFIED

AD NUMBER

AD824350

LIMITATION CHANGES

TO:

Approved for public release; distribution is unlimited.

FROM:

Distribution authorized to U.S. Gov't. agencies and their contractors;
Administrative/Operational Use; 16 JUN 1959.
Other requests shall be referred to Army
Aviation Materiel Laboratories, Fort Eustis, VA
23604.

AUTHORITY

USARTL ltr, 17 Mar 1981

THIS PAGE IS UNCLASSIFIED

GENERAL DECLASSIFICATION SCHEDULE

**IN ACCORDANCE WITH
DOD 5200.1-R & EXECUTIVE ORDER 11652**

THIS DOCUMENT IS:

CLASSIFIED BY _____

**Subject to General Declassification Schedule of
Executive Order 11652-Automatically Downgraded at
2 Years Intervals-DECLASSIFIED ON DECEMBER 31,**

BY

**Defense Documentation Center
Defense Supply Agency
Cameron Station
Alexandria, Virginia 22314**

AD 824350

CRASH INJURY REPORT



U. S. ARMY U-1A
De HAVILLAND OTTER ACCIDENT
Fort Carson, Colorado
16 June 1959

Each transmittal of this document outside the agencies of the US Government must have prior approval of U S Army Aviation Materiel Labs., Fort Eustis, Va., 23604

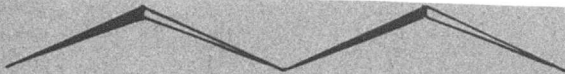

F S F

Aviation Crash Injury Research
of the **F**light **S**afety **F**oundation

2713 East Airline Way

Sky Harbor Airport
Phoenix, Arizona

D D C
RECEIVED
DEC 28 1967
B.C.

CRD 2459

COPY NO 230

DDC AVAILABILITY NOTICES

1. Distribution of this document is unlimited.
2. This document is subject to special export controls and each transmittal to foreign governments or foreign nationals may be made only with prior approval of US Army Aviation Materiel Laboratories, Fort Eustis, Virginia 23604.
3. In addition to security requirements which must be met, this document is subject to special export controls and each transmittal to foreign governments or foreign nationals may be made only with prior approval of USAAVLABS, Fort Eustis, Virginia 23604.
4. Each transmittal of this document outside the agencies of the US Government must have prior approval of US Army Aviation Materiel Laboratories, Fort Eustis, Virginia 23604.
5. In addition to security requirements which apply to this document and must be met, each transmittal outside the agencies of the US Government must have prior approval of US Army Aviation Materiel Laboratories, Fort Eustis, Virginia 23604.
6. Each transmittal of this document outside the Department of Defense must have prior approval of US Army Aviation Materiel Laboratories, Fort Eustis, Virginia 23604.
7. In addition to security requirements which apply to this document and must be met, each transmittal outside the Department of Defense must have prior approval of US Army Aviation Materiel Laboratories, Fort Eustis, Virginia 23604.
8. This document may be further distributed by any holder only with specific prior approval of US Army Aviation Materiel Laboratories, Fort Eustis, Virginia 23604.
9. In addition to security requirements which apply to this document and must be met, it may be further distributed by the holder only with specific prior approval of US Army Aviation Materiel Laboratories, Fort Eustis, Virginia 23604.

DISCLAIMER

10. The findings in this report are not to be construed as an official Department of the Army position unless so designated by other authorized documents.

11. When Government drawings, specifications, or other data are used for any purpose other than in connection with a definitely related Government procurement operation, the United States Government thereby incurs no responsibility nor any obligation whatsoever; and the fact that the Government may have formulated, furnished, or in any way supplied the said drawings, specifications, or other data is not to be regarded by implication or otherwise as

in any manner licensing the holder or any other person or corporation, or conveying any rights or permission, to manufacture, use, or sell any patented invention that may in any way be related thereto.

12. Trade names cited in this report do not constitute an official endorsement or approval of the use of such commercial hardware or software.

DISPOSITION INSTRUCTIONS

13. Destroy this report when no longer needed. Do not return it to originator.

14. When this report is no longer needed, Department of the Army organizations will destroy it in accordance with the procedures given in AR 380-5.

U. S. ARMY U-1A De HAVILLAND OTTER AIRCRAFT
Fort Carson, Colorado
16 June 1959

Report of Accident Investigation
AvCIR-9-PR-104
February 1960

for

U. S. Army
Transportation Research Command
Contract DA 44-177-TC-624

AVIATION CRASH INJURY RESEARCH
A Division of
Flight Safety Foundation, Inc.
2713 East Airline Way
Phoenix, Arizona

Crash-Injury Investigation

Jack Carroll
Harold F. Roegner

Crash-Injury Analysis

Jack Carroll
Harold F. Roegner
William R. Knowles, MSC, U. S. Army

Editorial Assistance

Wayne E. Spangler

TABLE OF CONTENTS

	Page
SUMMARY	1
CONCLUSIONS	3
RECOMMENDATIONS	5
BACKGROUND	6
DESCRIPTION OF THE ACCIDENT	7
General	7
Crash Sequence	8
Damage to the Aircraft	10
CRASH INJURY ANALYSIS	11
CRASHWORTHINESS COMMENTS	13
PICTORIAL ANALYSIS OF THE ACCIDENT	15
Intact Aircraft	15
Accident Scene - Exterior Views	15
Troop Seating Configuration	22
Accident Scene - Interior Views	25
Details of Seat and Seat Belt Damage	33
APPENDIX I Crash Force Analysis	57
APPENDIX II Summary of Medical Reports	58

SUMMARY

An Army U-1A De Havilland Otter engaged in a troop transport flight crashed in a ravine near Fort Carson, Colorado, at 09:25 MST on 16 June 1959. The aircraft sustained major damage as it came to rest inverted. The pilot and nine passengers survived the crash although they sustained injuries ranging from minor to severe.

A crash injury investigation revealed that injuries were the result of the occupants being thrown free due to seat and/or seat belt failures and striking interior structures and rifles.

The analysis of injury causation factors indicates the need for: (1) increased strength of seats and tie-downs, (2) a better restraint system for occupants, and (3) a method of stowing hard-carried weapons.

CONCLUSIONS

It is concluded that:

1. The impact condition was of a moderate nature.
2. Although the inhabitable areas of the aircraft remained reasonably intact, injuries were caused by:
 - a. Failures of seats and/or seat belts, which allowed occupants to be thrown free in the cabin.
 - b. Occupants striking interior structures such as bulkheads and fuselage walls.
 - c. Weapons held by the troops.
3. Seat belt failures were caused by:
 - a. The cutting action of the buckle-fastening mechanism.
 - b. Webbing failures.
 - c. Anchorage failures.

PRECEDING
PAGE BLANK

RECOMMENDATIONS

It is recommended that:

1. Passenger seats presently utilized in this aircraft be replaced with seats which will provide the passengers with a greater degree of safety during a survivable crash. Consideration should be given to the use of seats which will absorb energy through progressive collapse and have anchorage design strength at least equal to that of the primary aircraft structure.
2. Consideration be given to the use of a force-attenuating device at seat belt anchorage points to prevent excessive loading of the seats during a crash.
3. Energy absorption material, such as Ensolite (type 22266) be utilized to pad structural members within striking distance of cabin occupants.
4. Individual weapons such as rifles carried aboard the aircraft be stowed and securely restrained in a manner which will prevent injuries.
5. Quick release (metal-to-metal) type belt buckles be utilized to prevent belt webbing failures.
6. Nylon webbing be utilized for seat belts in all Army aircraft.

BACKGROUND

On 16 June 1959 a U. S. Army U-1A De Havilland Otter aircraft crashed approximately 5 miles SSW of Fort Carson, Colorado. The pilot, a combat scout leader, and eight combat-equipped troops sustained injuries that ranged in degree from minor/none to severe.

The crash injury investigation was conducted by Aviation Crash Injury Research (AvCIR), a division of the Flight Safety Foundation, Inc. The investigation was conducted at the request of the U. S. Army Board for Aviation Accident Research (USABAAR), Fort Rucker, Alabama. The purpose of the investigation was to determine causes of the injuries and to make recommendations for use in the formulation of crash-safety design criteria.

DESCRIPTION OF THE ACCIDENT

GENERAL

A U. S. Army De Havilland Otter (Serial No. 55-2974) crashed with the pilot, a combat scout leader, and eight combat-equipped troops aboard approximately 5 miles SSW of Fort Carson, Colorado, at 09:25 hours (Mountain Standard Time) 16 June 1959.

Following take-off, at an altitude of approximately 25 feet, the aircraft began to settle back toward the ground. The pilot, attempting to maintain flying speed, initiated a descent into an adjacent canyon to avoid striking rough terrain directly off the end of the runway. During this descent, the left horizontal stabilizer struck the trunk of a dead tree. The aircraft then struck the side slope of the canyon in extremely rugged terrain, impacting on its left wing, nose and left side; rolling to a partially inverted position before coming to rest approximately 60 feet beyond the point of initial ground impact. (See Figs. 3-4, p. 16.)

The cockpit and cabin remained reasonably intact. Major damage was sustained by the left wing, the left landing gear, the left lower side of the fuselage, and the engine and nose section. All occupied cabin seats except two were either torn free, broken, or distorted.

The pilot and combat scout leader (who was seated in the copilot's seat) escaped through the broken front windshield. Seven cabin passengers evacuated the aircraft through the left main door, which had been torn free. The remaining passenger required assistance from the wreckage. Several of the passengers in the cabin were drenched by gasoline pouring down from the ruptured fuel tanks.

Medical examination revealed that the passenger who required assistance from the aircraft had sustained a dislocated hip and lacerations. Four passengers had suffered lacerations and abrasions, and the other five occupants had sustained only minor lacerations and abrasions. The pilot and scout leader in the copilot's seat were wearing safety belts and shoulder harnesses; troops in the cabin were wearing only seat belts, some of which failed in the crash.

CRASH SEQUENCE

As the aircraft descended into the canyon, the left horizontal stabilizer struck the trunk of a dead tree, shearing off part of the stabilizer and elevator. (See Kinematics Diagram, p. 9, and Fig. 12, p. 21.) At the time of this impact the aircraft was flying at minimum flying speed in a nose-high attitude with the left wing slightly down. The impact caused the aircraft to yaw approximately 10 degrees to the left and to begin rolling to the left while continuing to move forward and downward.

The left wing tip and the left landing gear struck the side slope of the canyon followed by the engine nacelle and the forward fuselage. The attitude of the aircraft at the instant of impact with the ground was slightly nose high, yawed approximately 10 degrees to the left, with the left wing down 60 degrees in relation to the horizontal (20 degrees in relation to the 40-degree, left-to-right slope of the terrain). The impact speed is estimated to have been 50 to 55 knots. The angle of impact with the ground was 15 to 20 degrees. The approximate direction of the principal crash force was from a point 40 to 50 degrees below and 20 degrees to the left of the longitudinal axis of the aircraft.

As the aircraft struck the ground, the left landing gear was wiped rearward and upward into the bottom of the fuselage, rupturing the fuel cells in the belly and causing a large section of the cabin floor to heave upward. The left wing was rotated rearward and upward as the aircraft continued to roll to the left, causing inward displacement of the cabin wall and the ceiling structure adjacent to the wing root. The aircraft continued to slide along the ground progressively rolling over to a partially inverted position before coming to rest about 60 feet from the point of initial ground impact. The left wing came to rest under the aircraft. (See Fig. 2, p. 15.)

KINEMATICS DIAGRAM - U. S. Army U-1A De Havilland Otter Accident

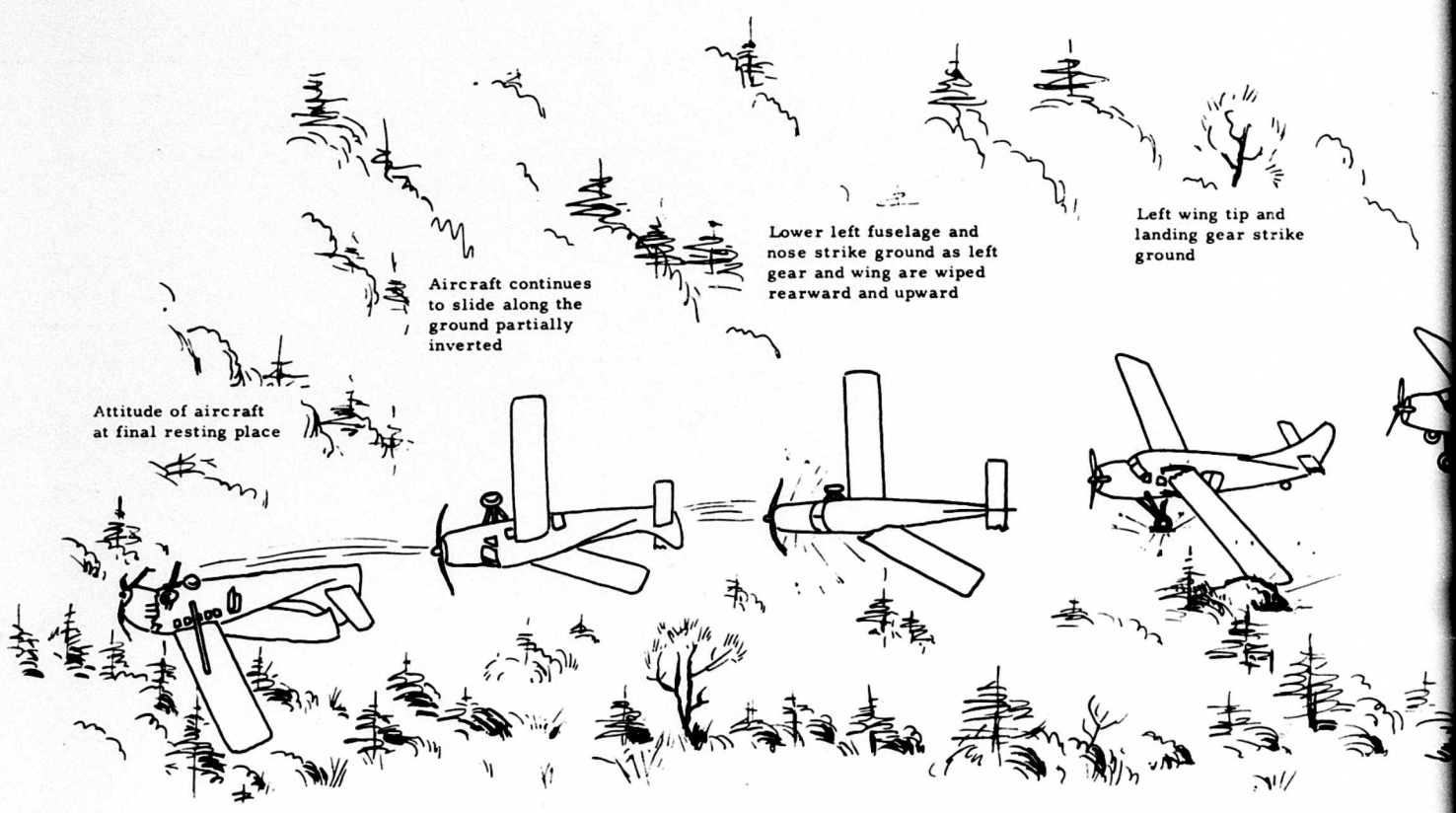

A

1A De Havilland Otter Accident, Fort Carson, Colorado, 16 June 1959

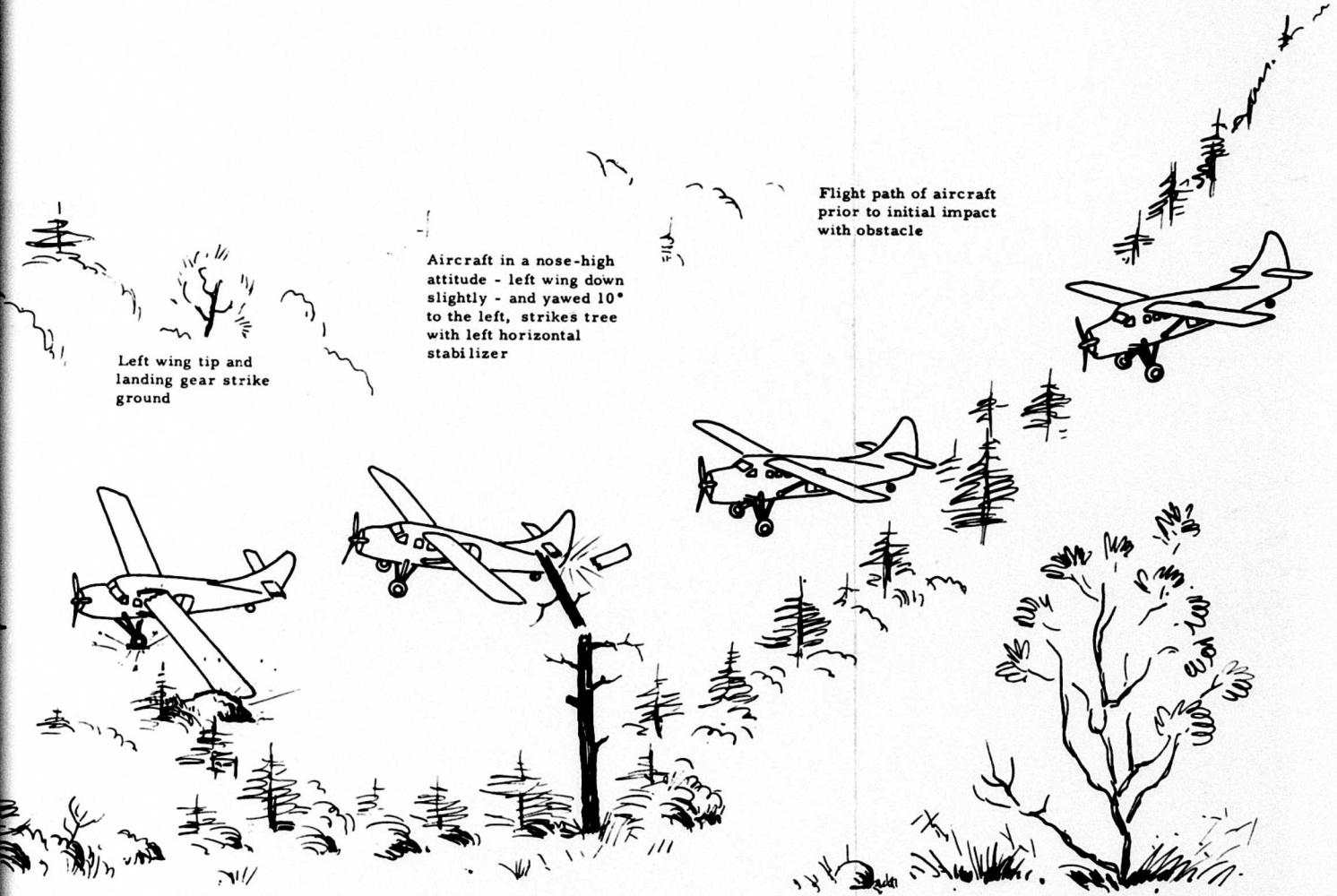

Left wing tip and landing gear strike ground

Aircraft in a nose-high attitude - left wing down slightly - and yawed 10° to the left, strikes tree with left horizontal stabilizer

Flight path of aircraft prior to initial impact with obstacle

B

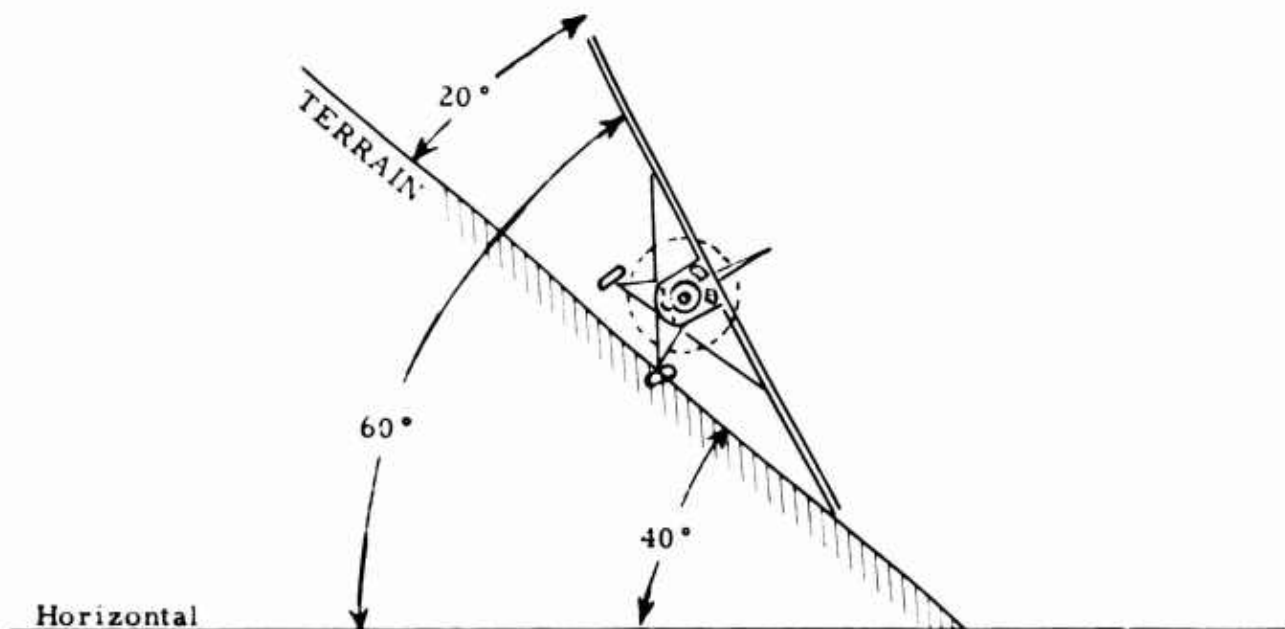

View looking rearward along the flight path, showing the roll attitude of the aircraft in relationship to the horizontal and the terrain at principal impact with the ground.

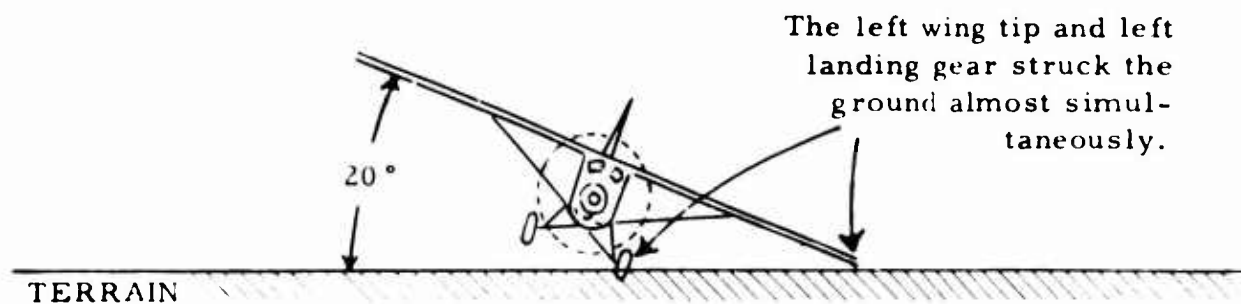

View showing the wing-down attitude of the aircraft in relationship to the terrain at principal impact. (Slope of the terrain has been rotated to the horizontal.)

DAMAGE TO AIRCRAFT

The exterior structure of the cabin and cockpit was generally intact with the exception of heavy buckling damage to the left wing root area, moderate to severe buckling of the belly structure (in the vicinity of the forward fuel cells) and distortion of the main cabin door frame.

The engine was partially torn free during the principal impact; the underside of the nose section was severely buckled. The left landing gear collapsed upward and rearward into the belly of the aircraft. The left wing "hinged" at the root and was swept aft, remaining only partially attached to the fuselage. The outer portion of the left horizontal stabilizer and elevator were torn free.

The interior of the cockpit and cabin was generally intact except for some buckling of the ceiling and wall structure in the vicinity of the left wing root and upheaval of portions of the cabin and cockpit floor. Various components, such as the control wheel column, pilot's seat and some passenger seats, were torn free and/or severely damaged. Both the main cabin door and the overhead emergency exit were torn free at impact.

CRASH INJURY ANALYSIS

Of the ten persons occupying this aircraft* five escaped with only minor abrasions and lacerations; the remaining five sustained more serious injuries. Injuries sustained by each occupant** and their causes were as follows:

Pilot - The pilot, occupying the left front seat (Figs. 18, 30-35) received minor injuries which were sustained as he evacuated the aircraft through the broken windshield. At principal impact he was thrown forward, downward and to the left as the aircraft struck the ground. His shoulder harness, which was attached to the bulkhead separating the cockpit and cabin, functioned properly and prevented his body and head from being thrown against the control wheel and/or instrument panel.

Copilot - The combat scout leader occupying this seat (Figs. 36-37) received minor injuries during his evacuation from the aircraft through the broken windshield. As in the case of the pilot, his restraint system functioned properly, preventing him from striking cockpit structures and components during the crash.

Seat 1L - The occupant of this seat (Figs. 38, 44) received minor injuries. Although his seat remained in place, he was allowed to flex forward (restrained by his seat belt) striking the left rear portion of his head against the forward bulkhead.

Seat 1R - The occupant of this seat (Fig. 48) received moderate injuries. His injuries consisted of a 4-inch laceration on the top of his head and an abrasion of the left flank. These injuries were caused by striking his head and upper torso against the forward bulkhead, even though he was restrained by his seat belt.

Seat 2L - The occupant of this seat (Figs. 39, 40, 45) sustained minor injuries consisting of lacerations of the left side of his chin and contusions of the lower lip. These injuries were caused by striking the muzzle of the rifle which he was holding upright between his knees.

Seat 2R - The occupant of this seat (Fig. 49) was thrown free in the cabin when both his seat and seat belt failed completely. He received moderate injuries which consisted of lacerations on top of his head and above the left eye; abrasions of the shoulder, left hand and right shin. His injuries resulted from (1) being thrown completely free in

* Seating and damage charts are shown on pp. 33, 34, and 35.

** Refer to Summary of Medical Reports, pp. 58 and 59.

the cabin and striking interior structures and (2) striking the muzzle of his rifle.

Seat 3L - The occupant of this seat (Figs. 40, 41, 46) received moderate injuries, although seated in the area of the cabin where the ceiling, wall and floor structure was badly buckled and collapsed (Fig. 40). Lacerations above the right eye, bridge of the nose, and upper lip were caused by striking the muzzle of the rifle which he was holding upright between his knees; abrasions of the left temple and front of the left ear were caused by striking adjacent cabin wall structure and/or seat structure in front of him.

Seat 3R - The occupant of this seat (Fig. 50, 52) received severe injuries and required assistance in evacuating the wreckage. His injuries consisted of a dislocation of the hip and moderate abrasions. The simultaneous failure of his seat anchorages and safety belt allowed him to be hurled through the cabin striking interior structures and components.

Seat 4L - The occupant of this seat (Figs. 42, 43, 47) sustained moderate injuries to his head and right knee. His injuries consisted of a 2-inch laceration on the top of his head, a 3-inch laceration on his right forehead and a torn ligament in the right knee. These injuries were caused by partial failure of his seat which allowed him to move forward, downward, and to the left, as the seat pivoted around the intact wall fitting (Fig. 24) allowing him to strike the cabin wall and rear door frame.

Seat 4R - The occupant of this seat (Figs. 51, 52) sustained minor injuries although the failure of his safety belt resulted in his being thrown forward and to the left across the aircraft cabin. His injuries consisted of abrasions of the left forehead, cheek, and chin and loss of two teeth. It is believed that these injuries were caused by a combination of striking the muzzle of the rifle which he was holding upright between his knees and/or striking interior cabin structures and components.

In summary, the injuries sustained by the occupants seated in the cabin are attributed to:

1. Failures of seats or seat belts.
2. Striking interior structures and components.
3. Striking or being struck by rifles which were being held upright between their legs.

CRASHWORTHINESS COMMENTS

The crash forces involved in this accident were relatively moderate as indicated by the crash force analysis (Appendix I).

Previous crash injury studies have determined that a good crash survival criterion is that the failure and collapse of non-occupiable areas of the aircraft should not result in extensive damage or destruction of the cabin and cockpit areas. It is interesting to note that in this accident the failure of the non-occupiable structure (wing, belly, landing gear) did not cause a substantial amount of damage to the inhabitable areas; the cabin and cockpit remained relatively intact. In addition, the progressive collapse of the wing and belly structures absorbed a considerable amount of energy during the principal impact, preventing high decelerative forces from being transmitted to the intact areas of the fuselage.

In light of the apparent crashworthiness of the Otter fuselage when exposed to moderate impact conditions, it is interesting to note the high percentage of failures of cabin seats and safety belts. The inability of the seats and seat belts to withstand the crash loads experienced in this accident while surrounding cabin structures remained relatively intact is directly related to the injuries sustained by the occupants. An examination of the design specifications for the seats in this aircraft reveals they were designed for 9G forward, 3G upward, 1.5G side, and 6.6G down for a 190-pound man. Since the crash forces experienced during the accident were in excess of the above cited specifications, failure of the seats could be expected. However, since the crash forces were within survivable limits and the structure of the fuselage remained relatively intact, it is suggested that a re-evaluation of the specifications be made and the minimum standards for seats be increased to provide a higher degree of injury protection to the occupants.

Also, consideration should be given to: (1) Use of a well-designed seat which is readily stowable and/or removable. The seat should be designed to yield or deform progressively without complete failure during the imposition of crash loads, thereby absorbing energy which would otherwise be transmitted directly to the occupants. In addition, the seats should be well anchored to primary structure with a tie-down strength at least equal to the strength of the basic floor and cabin structures. (2) Anchoring seat belts to primary structure in lieu of attachment to the seats to prevent loading of the seat during imposition of crash forces. The use of attenuating devices at the seat belt anchorages is also suggested in order to further reduce the load on both the occupant and the belt attachment points. (3) Use of nylon seat belts rather than cotton. Nylon is capable of withstanding higher snap or jolt loads without failing. It is also suggested that the seat belt buckles be the metal-to-metal type to eliminate webbing failures due to the cutting action of the serrated cam type buckle.

PICTORIAL ANALYSIS OF THE ACCIDENT

INTACT AIRCRAFT



Fig. 1. Intact U-1A Otter

ACCIDENT SCENE - EXTERIOR VIEWS

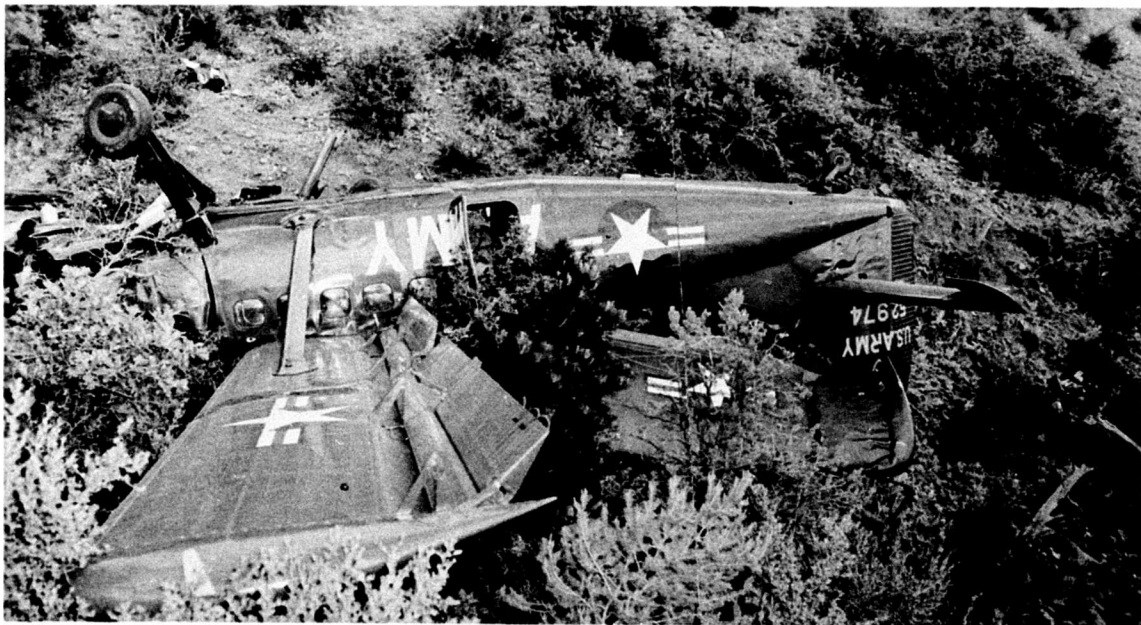

Fig. 2. Final position of wreckage after the crash (composite photo).



Fig. 3. View looking forward along flight path (indicated by line of arrows) showing final resting place of the aircraft. The dead tree (arrow 1) was struck by the leading edge and underside of the left horizontal stabilizer at a point approximately 6 feet above the present top of the tree trunk.

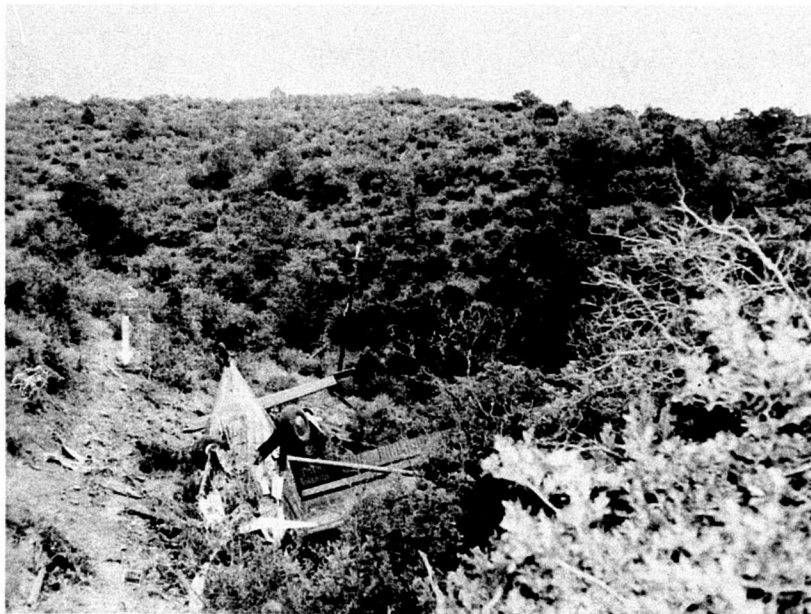

Fig. 4. View looking rearward along the crash path, showing the point of initial impact (arrow) of the aircraft in relationship to its final resting place. Shortly after coming to rest in a partially inverted attitude, the aircraft (after being evacuated) was rolled to a completely inverted attitude by strong winds.



Fig. 5. View showing gouging (arrow) caused by the aircraft's decelerating along the ground following the principal impact. Note the relative intactness of the rear cabin and fuselage structure.



Fig. 6. The side slope of the terrain at the point of principal impact with the ground was approximately 40 degrees. Analysis indicates that the left wing of the aircraft was down about 60 degrees when the wing tip first struck the ground; this resulted in a 20-degree wing-down angle with relation to the terrain at the instant of impact. Note the gouge (arrow) caused by the left landing gear.



Fig. 7. View showing overall damage to the underside of the fuselage, landing gear, and nose structure. The main cabin door was torn free during the crash, and the open doorway (arrow) was subsequently utilized for evacuation by the cabin passengers.

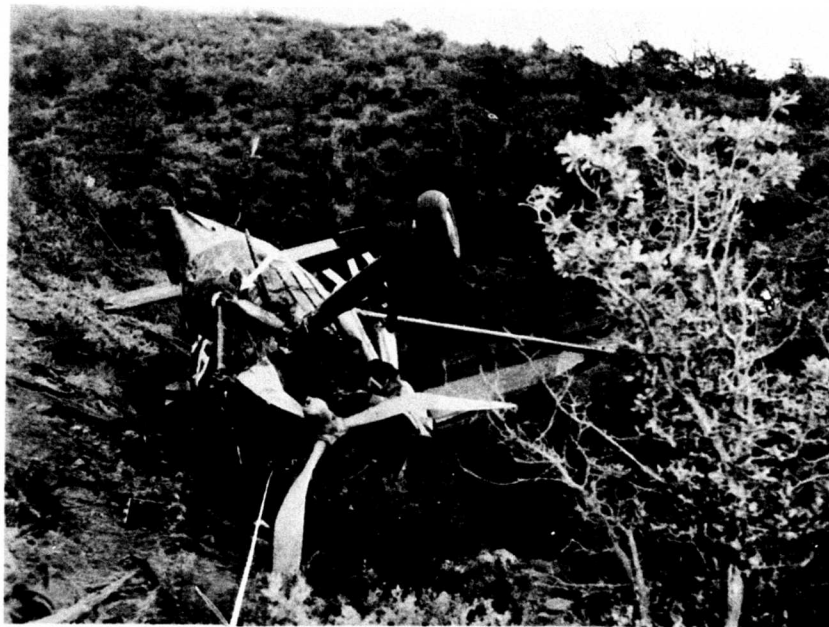

Fig. 8. View of the lower fuselage, showing the extent of rearward displacement of the left landing gear (arrow) and the damage sustained by the belly, engine, and nose areas. The collapse of structure in these areas absorbed an appreciable amount of crash energy and thus reduced the forces transmitted to the cockpit and cabin and to their occupants.



Fig. 9. The lower left fuselage section, slightly aft and below the cockpit (arrow 1), struck the ground immediately after the left landing gear collapsed. As the left gear was swept rearward and upward, fuel cells located in the belly of the aircraft were ruptured (arrow 2), and the lower main cabin door frame was distorted (arrow 3).

Simultaneously, the left wing, pivoting at its root, was forced rearward and upward as the aircraft continued to roll over on its left side. This resulted in an inward displacement of the left cabin wall and ceiling and in severe distortion of the upper main cabin door frame (arrow 4).



Fig. 10. View of damage to fuel cell area (arrow 1), main cabin door frame (arrow 2), and upper left cabin structure (arrow 3). Gasoline flowing downward into the cabin from the ruptured fuel cells drenched the occupants.

Although two occupants were seated adjacent to the structure that was severely damaged by the inward collapse of the wing root (arrow 3), both escaped serious injury. Upheaval of the cabin floor structure, caused by the left landing gear's collapsing upward into the fuselage area (arrow 1), occurred directly beneath the seat of one of these two occupants and resulted in partial failure of the seat anchorages.

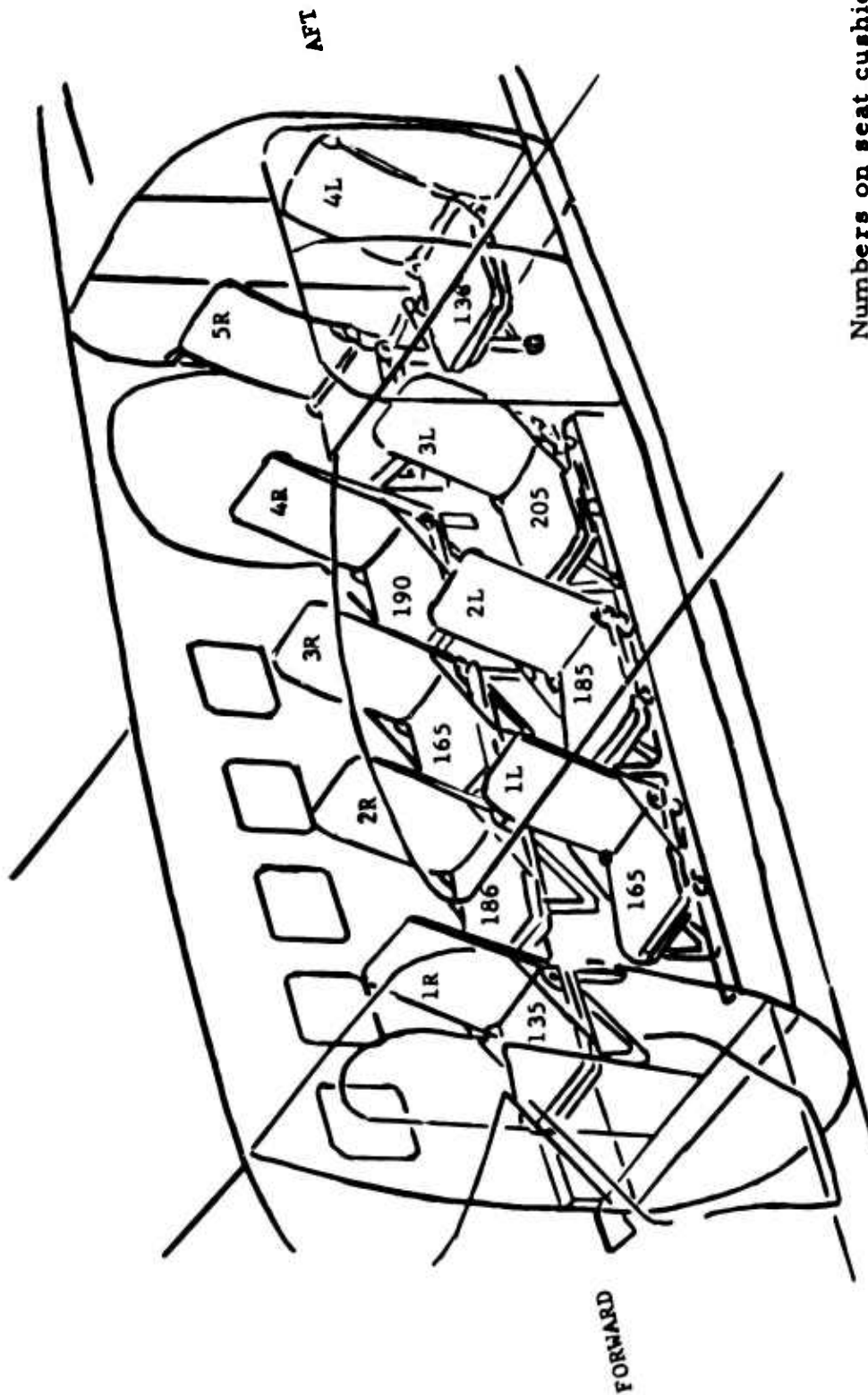

Fig. 11. The cockpit doorway (arrow), although "popped" open during the crash, was not available as an emergency exit because the aircraft was resting partially on its left side. The pilot and copilot escaped through the broken front windshield.



Fig. 12. Impact damage (arrow) to the leading edge and underside of the left horizontal stabilizer was caused by initial impact with a dead tree. This outer portion of the stabilizer along with the entire left elevator subsequently tore free prior to principal impact of the aircraft with the ground.

TROOP SEATING CONFIGURATION



Numbers on seat cushions
are weights of occupants.
5R was unoccupied.



Fig. 13. View looking aft in the cabin of an intact U-1A Otter aircraft, showing the seating configuration utilized for the transportation of combat troops.



Fig. 14. View looking forward in the cabin, showing the seating arrangement utilized in transporting combat troops.



Fig. 15. View of the left-hand cabin area, showing the manner in which combat troops position their weapons during flight. (Passenger occupying the rearmost seat is not shown.)



Fig. 16. View of the right-hand cabin area, showing the seating configuration utilized in transporting combat troops. (Note positioning of weapons, with muzzle near face and head.)

ACCIDENT SCENE — INTERIOR VIEWS

The aircraft came to rest in a partially inverted position. Occupants who were still restrained were hanging upside down in their seats. Occupants whose safety belts had failed during the principal impact had been subsequently thrown "upward" against the ceiling. All interior views have been oriented to show the cabin in a normal, upright position



Fig. 17. Interior view (composite photo) of "intact" cockpit area. The upheaval and collapse of the floor structure (arrow 1) and the tearing free of the control column (arrow 2) probably occurred at the principal impact.

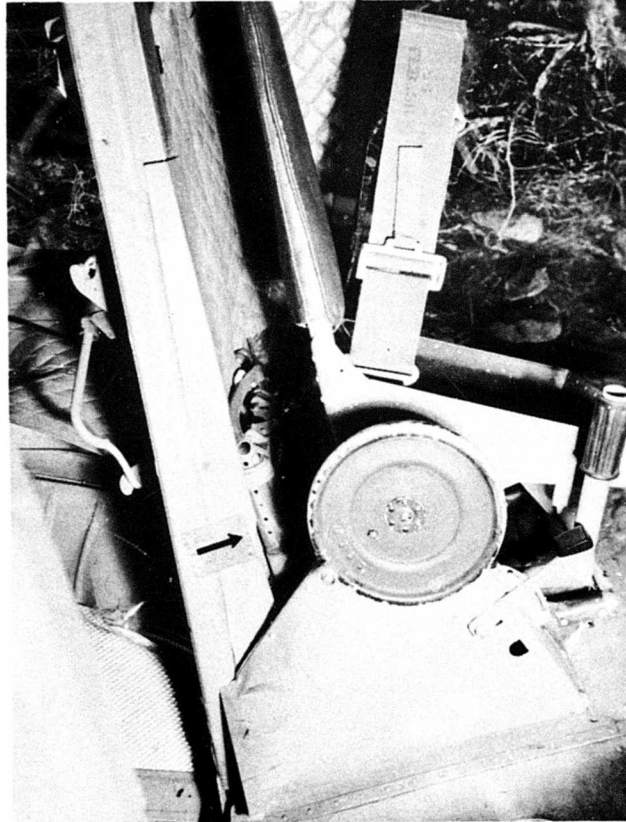

Fig. 18. The pilot's seat was broken forward, downward, and to the left, tearing almost completely free (arrow) from its attachments to the rear tubular supporting members. The pilot, restrained by a shoulder harness and a safety belt, both of which functioned properly, sustained only minor injuries.

Analysis of the seat failure indicates that the restraint provided by the shoulder harness (anchored to the bulkhead separating the cockpit and cabin areas) prevented the seat from tearing completely free at impact.

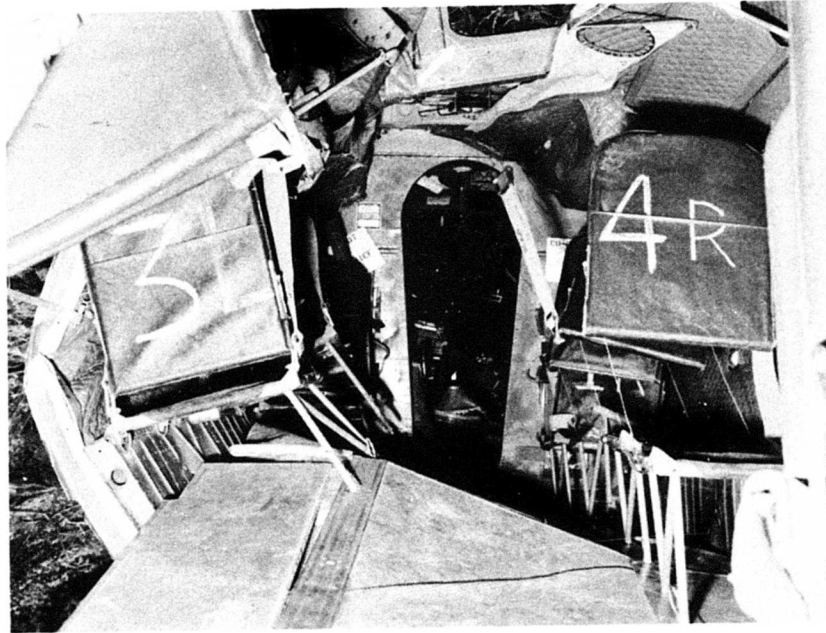

Fig. 19. View showing forward cabin area. Upheaval of the cabin floor structure was caused by the left landing gear's collapsing upward and rearward into the bottom fuselage area during the principal impact. The overhead emergency exit (arrow) popped out during the crash and was found underneath the wreckage.

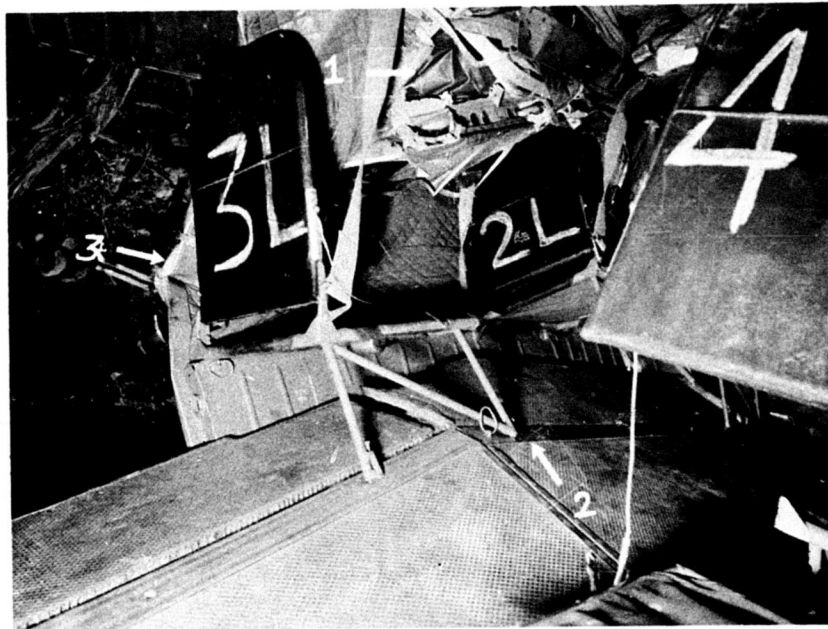

Fig. 20. Rearward hinging of the left wing root pushed the cabin wall and ceiling structure into the area (arrow 1) between seats 2L and 3L. The forward aisle attachment of seat 3L tore free from the floor (arrow 2) because of the upward displacement of the floor structure. Note the distortion of the main cabin door frame (arrow 3).

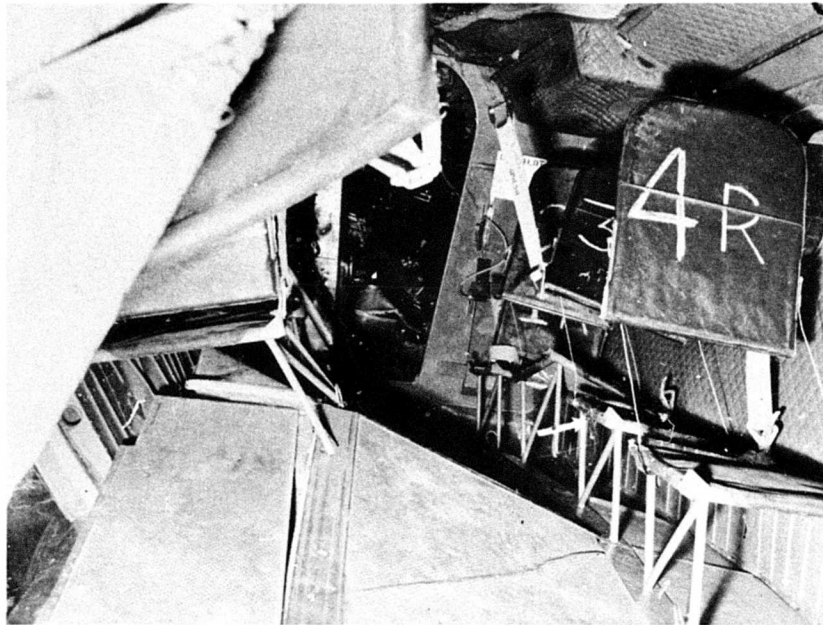

Fig. 21. View of the right side of the cabin (looking forward). The right-hand sidewall and ceiling structure sustained very little impact damage and remained completely intact. Seat 3R (arrow) was torn completely free during the crash. (It was replaced in its normal position prior to being photographed.)

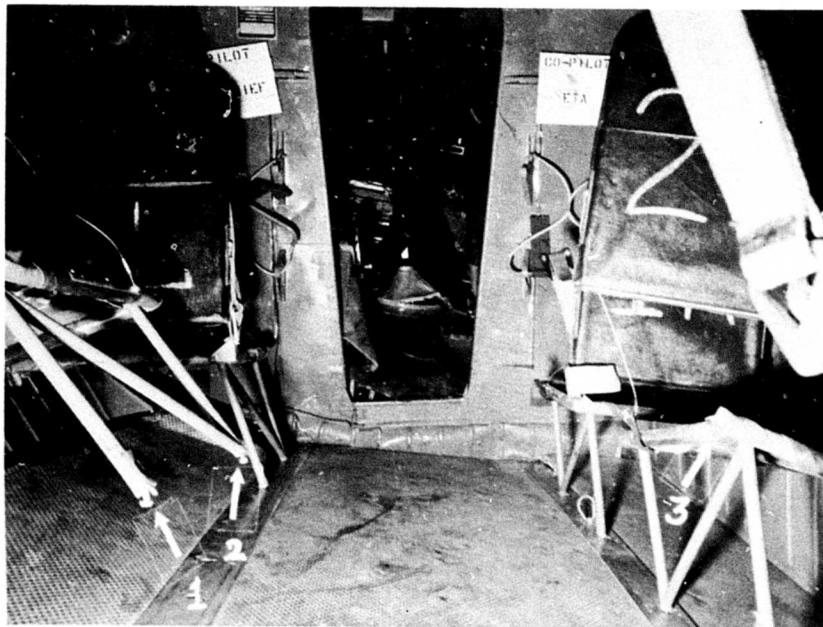

Fig. 22. View of forward cabin and cockpit areas. Failure of both aisle floor attachments on seat 2L (arrows 1 and 2) was apparently caused by the upward displacement of the cabin floor. The seatback on 2R was torn free from the seat pan (arrow 3); both rear anchorages of seat 2R failed.

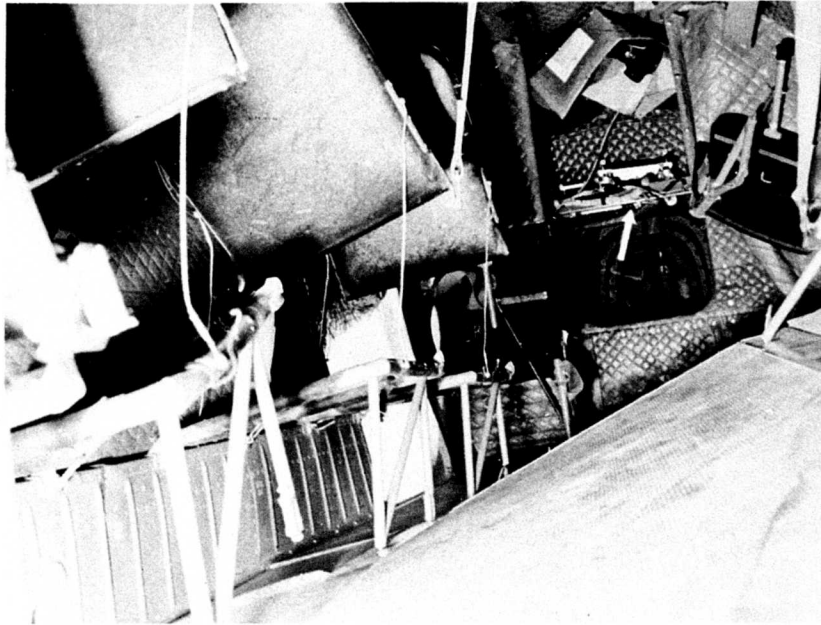

Fig. 23. View of cabin, showing the extent of upward displacement of the floor structure. The shelf utilized for installation of radio equipment (arrow) was not damaged in the crash. (Radio equipment was removed before this photograph was taken.)

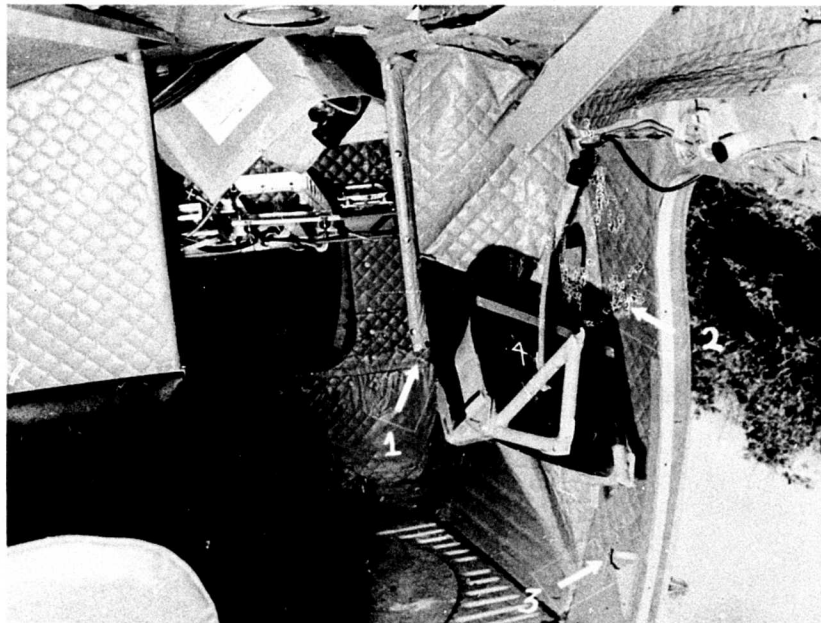

Fig. 24. View of after cabin showing failure of seat 4L and damage to luggage compartment. Seat 4L, normally attached to the luggage compartment post (arrow 1), to the upper and lower cabin wall (arrow 2 and 3), and to the cabin floor, tore partially free; the seat remained attached only by the upper wall fitting (arrow 2). The upper wall attachment, although intact, was badly distorted.



Fig. 25.
View showing failure of luggage compartment post (arrow 1) at the attachment point of seat 4L. The attachment bracket is indicated by arrow 2.



Fig. 26. View of the right-rear cabin area. A toolbox that was carried unsecured on the luggage compartment floor (arrow 1) was found rammed against the left vertical support of seat 5R (arrow 2), and impaled on two exposed bolt ends. It remained attached to them as the aircraft rolled to a partially inverted attitude during the crash sequence.

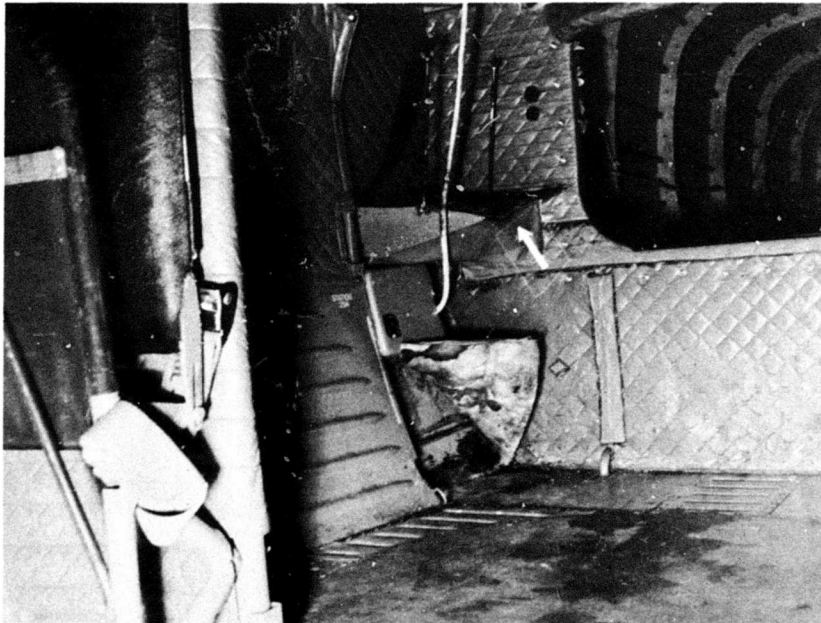

Fig. 27. View of luggage compartment showing downward distortion of the left forward portion of the battery rack (arrow).



Fig. 28. Looking forward in the cabin after removal of the passenger seats. Note the upward displacement of the cabin floor and the inward displacement of the left cabin wall and ceiling structure in the vicinity of the wing root (arrow).

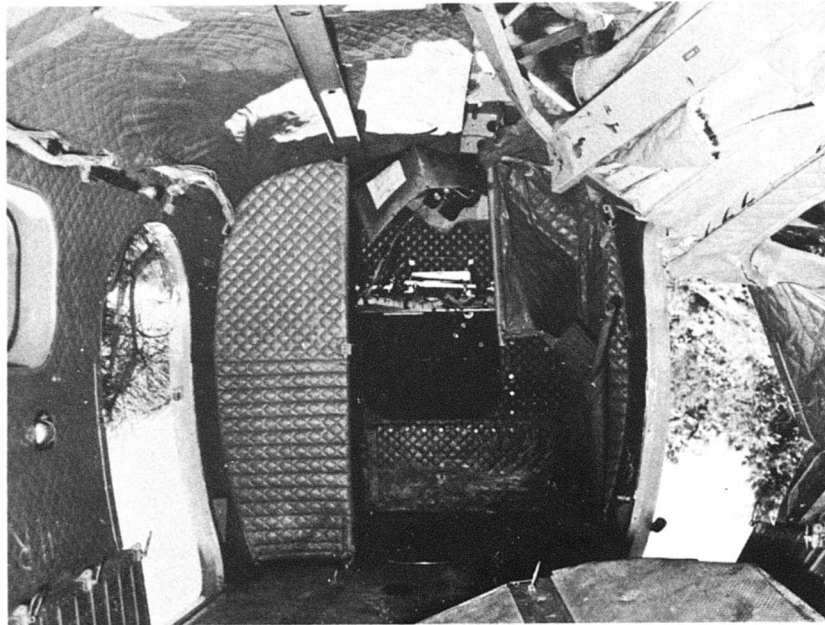
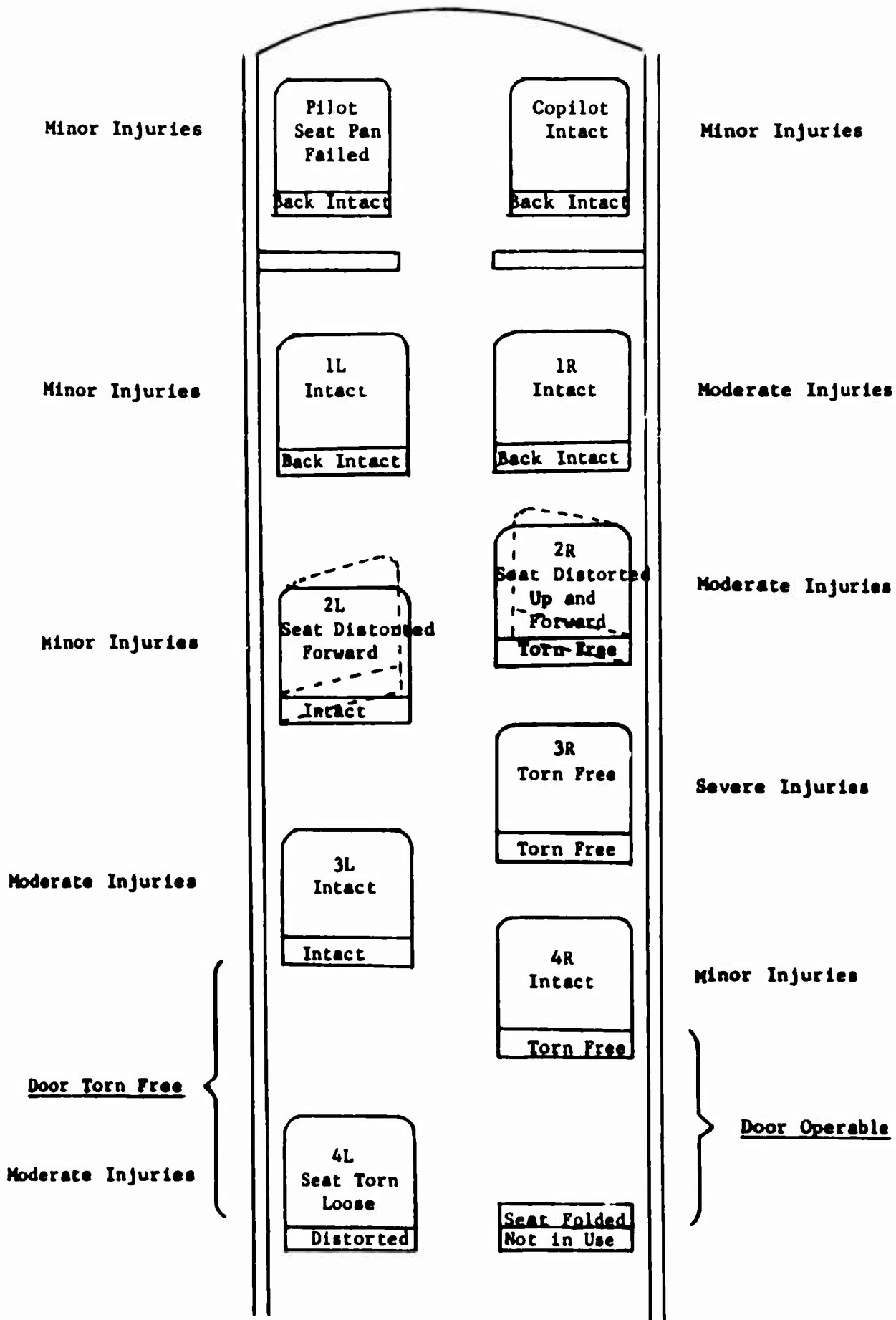
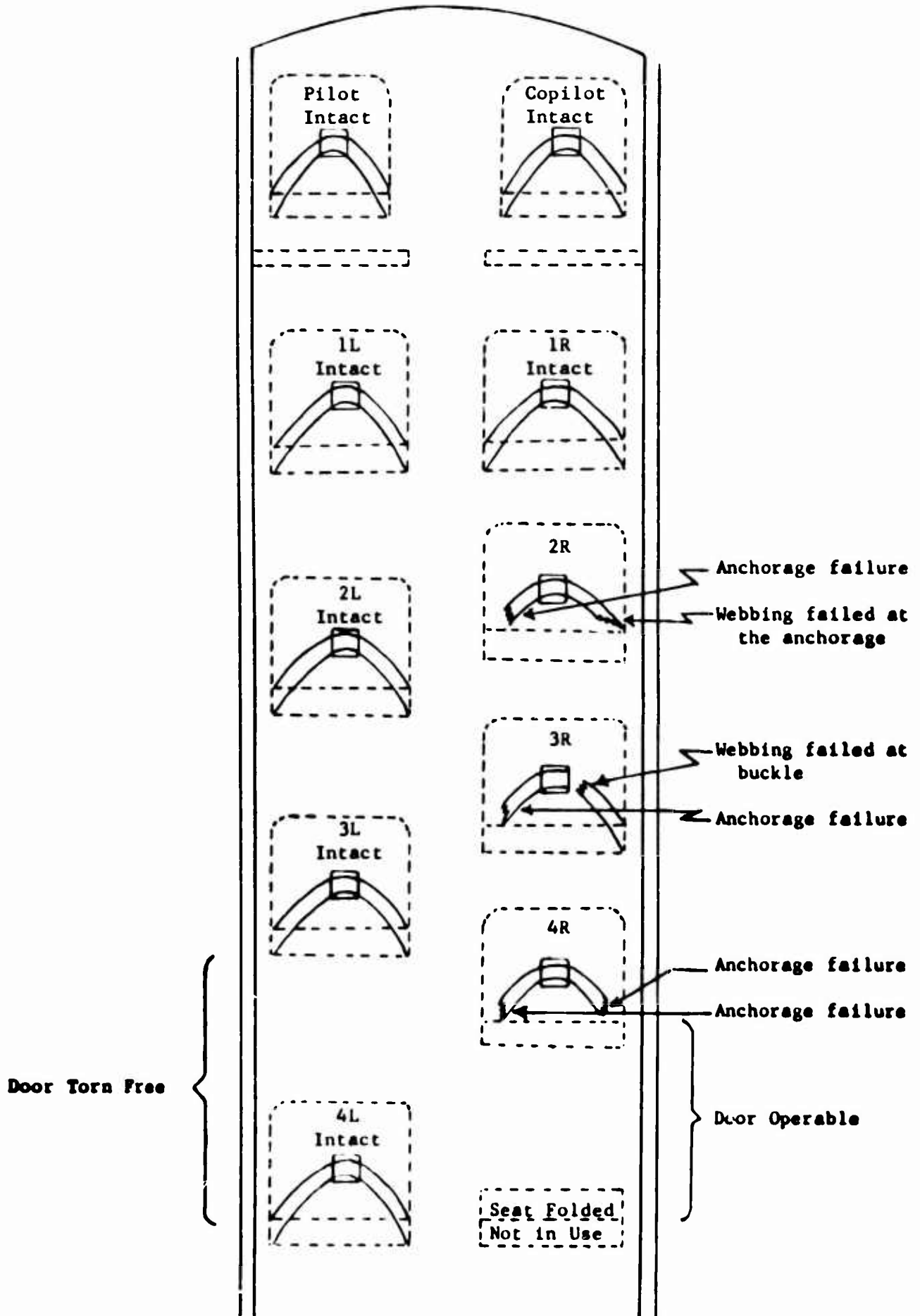

Fig. 29. Looking aft in the cabin following removal of the passenger seats. The upheaval of the cabin floor and the damage to the left cabin wall in the vicinity of the wing root are readily apparent.

SEAT DAMAGE AND PASSENGER INJURIES



CONDITION OF SEAT BELTS



CONDITION OF SEAT ATTACHMENTS

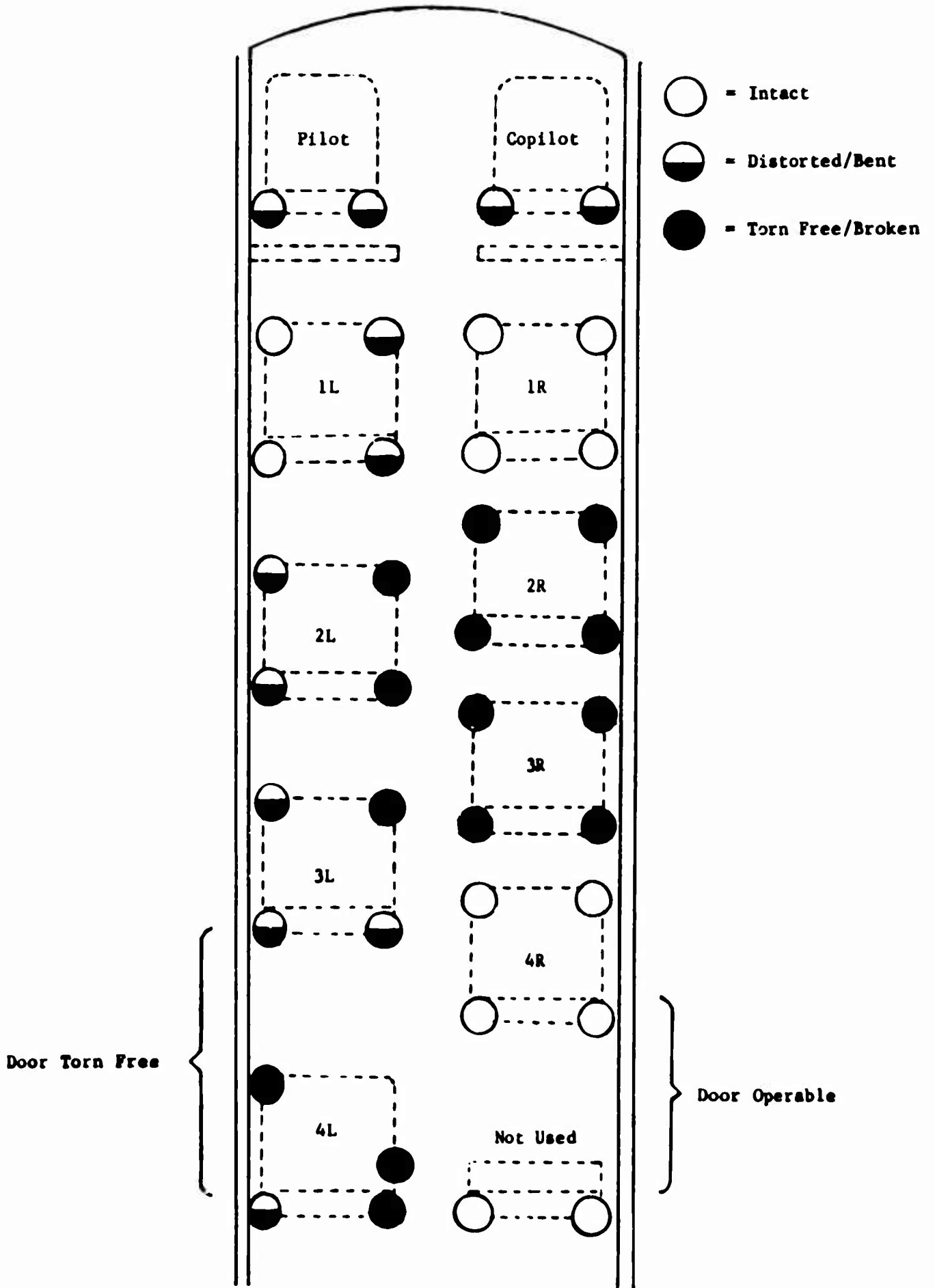

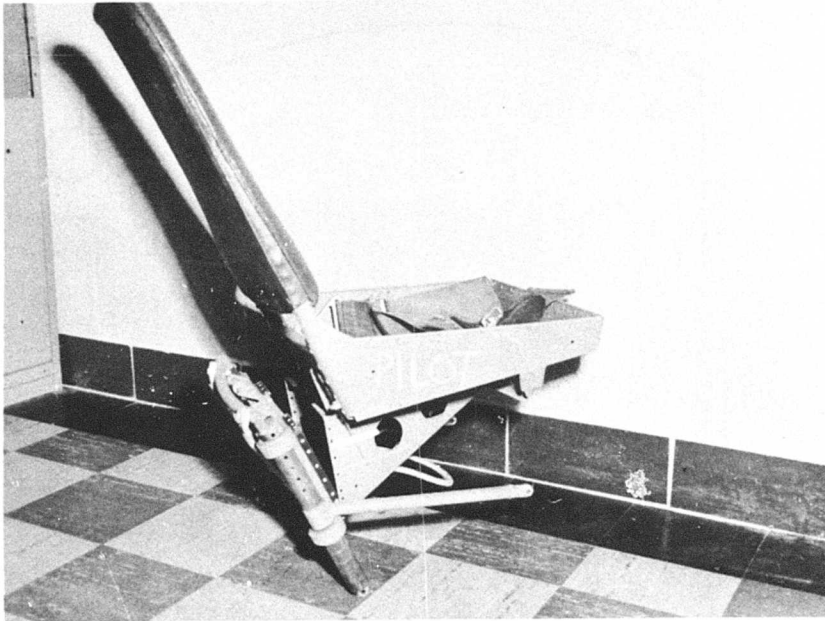

Fig. 30. Failure of the pilot's seat pan, due to shearing of the rivets which attach it to the primary support structure (arrow).

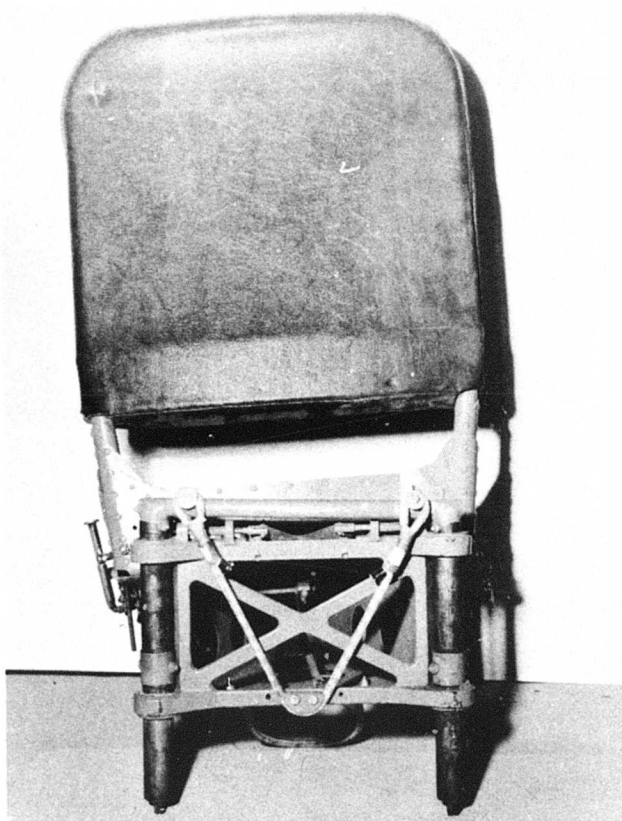

Fig. 31. Rear view of pilot's seat. Note the distortion of the seat pan and the seat back (downward and to the left).

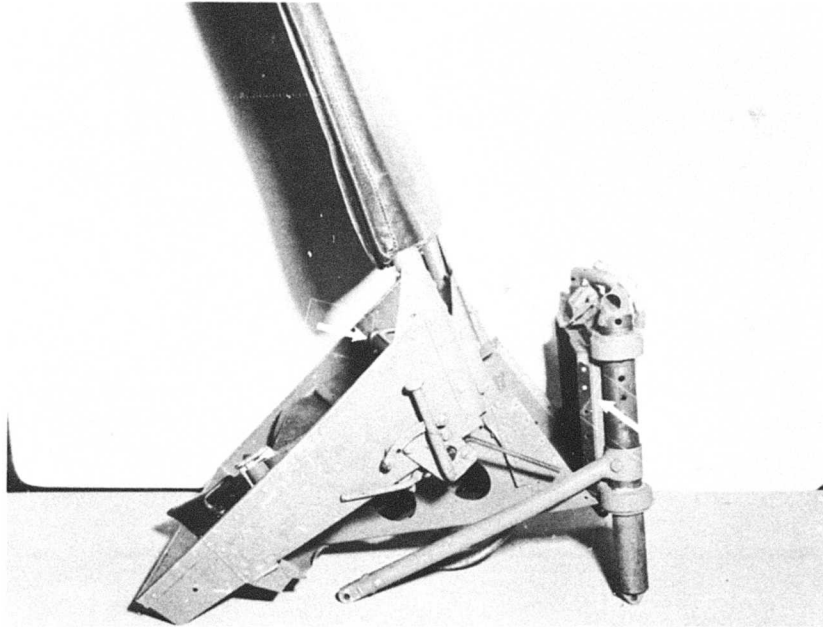

Fig. 32. View of the pilot's seat, showing failure of the seat pan at its left-hand attachment to the rear tubular supporting members (arrow 1). Analysis of the damage to the seat pan indicates that it failed downward and to the left, tearing almost completely free from the rear support assembly. The seat pan, which was free to move in a downward direction, bottomed on the left horizontal support member and/or the cockpit floor structure.

The pilot's shoulder harness, which was attached to the bulkhead separating the cockpit and the cabin, functioned normally and prevented his body and head from being thrown against the control wheel and the instrument panel as the seat failed. His safety belt, anchored to the rear inside corners of the seat pan (arrow 2), would have been useless because of the failure of the seat had it not been used in conjunction with the shoulder harness.

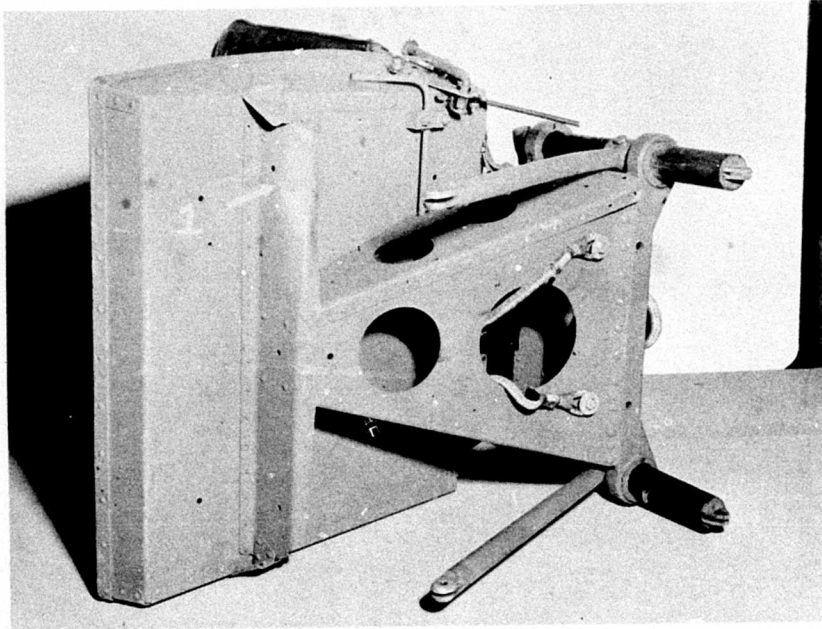

Fig. 33. Close-up view of the underside of the pilot's seat pan, showing bending and distortion of the support bracket (arrow 1) due to bottoming of the seat pan on the horizontal seat-supporting assembly and/or cockpit floor.

As the aircraft struck the ground at the principal impact, the pilot was thrown forward, downward, and to the left. His shoulder harness locked and thus prevented his upper torso from jackknifing forward.

The restraining action of the shoulder harness translated the forward momentum of the pilot's body to a vertical component, and thus resulted in an increased load on the seat pan.



Fig. 34. The outward distortion of the left side of the pilot's seat pan (arrow 1) was due to the pilot's being thrown forward, downward, and to the left during the principal impact.

Note the attachment of the safety belt to the inner rear corners of the seat pan (arrow 2).

The pilot received only minor injuries, which were apparently sustained as he evacuated the cockpit through the windshield.

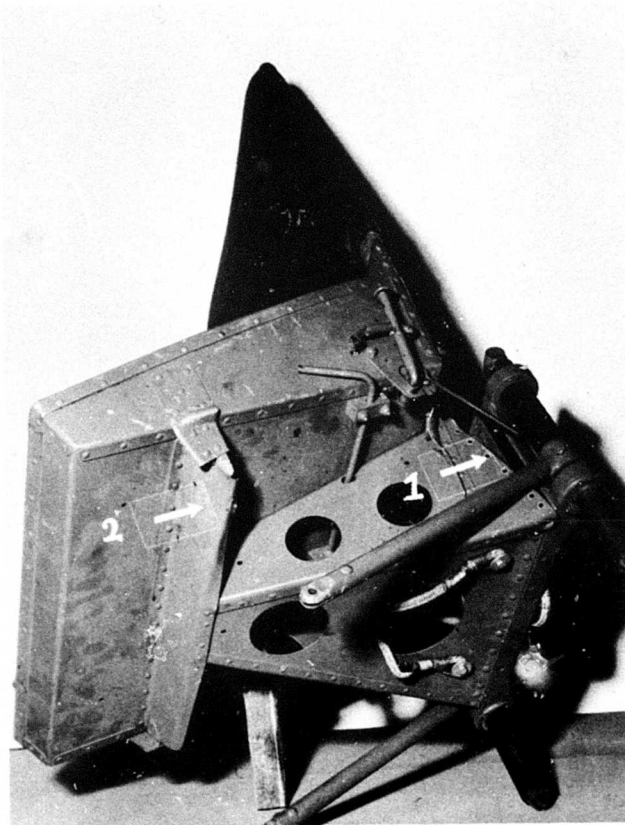

Fig. 35. View of the damage sustained by the pilot's seat, caused by the seat pan's tearing almost completely free from the rear supporting member (arrow 1) and bottoming against the lower horizontal supporting assembly (not shown) and/or cockpit floor. Note bending of the seat pan supporting bracket (arrow 2). Analysis of the damage to the support bracket (arrow 2) indicates that the force with which the seat pan bottomed was relatively low.



Fig. 36. The copilot's seat was intact and showed no evidence of any damage. Both the occupant's shoulder harness (attached to the bulkhead) and seat belt (attached to a bracket joining the inner rear corners of the seat pan and the vertical seat-back support members) functioned properly during the crash.

The person occupying this seat received only minor injuries, which were apparently sustained during his evacuation from the aircraft through the broken windshield.

Note the difference in design of the supporting structure of this seat (arrow) as compared to the pilot's seat.

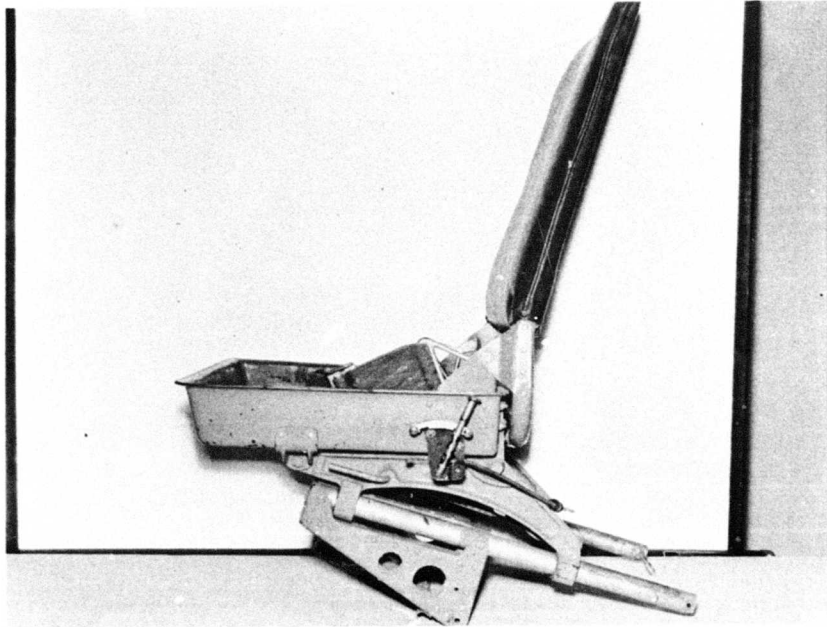

Fig. 37. The copilot's seat, designed to withstand 9g horizontally and a load equal to 6g vertically (upward) when occupied by a person weighing 190 pounds, did not fail, although the calculated crash force apparently exceeded the seat's design limits.

The crash force involved in this accident was calculated to have been relatively low (approximately 10g horizontally and 10.5g vertically).

This lack of failure may have resulted from the fact that the passenger occupying the seat weighed only 140 pounds; this means he would have had to exert a force equal to approximately 8g vertically on the seat pan before the design limits of the seat would have been reached. This is within 2.5g of the calculated vertical deceleration.

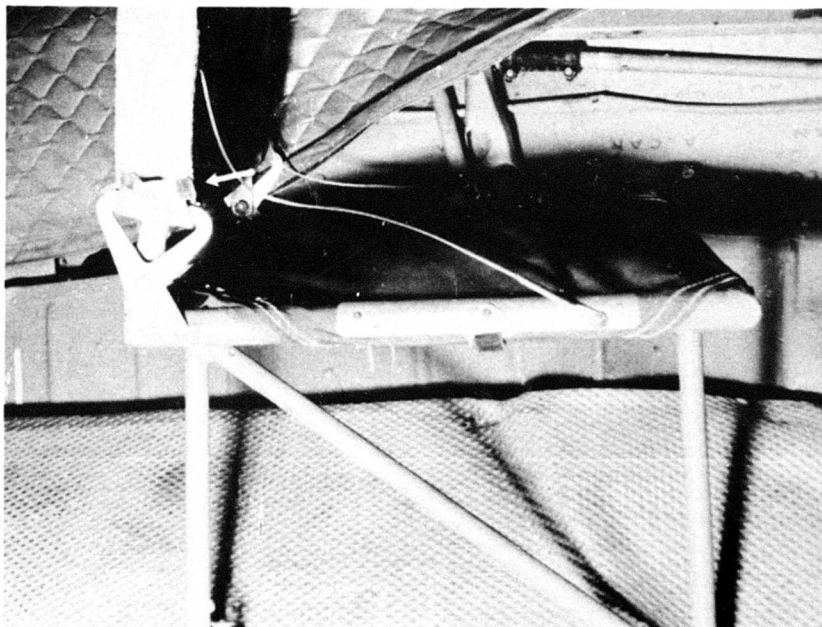

Fig. 38. Seat 1L, which is shown in its normal position in the cabin, remained completely intact during the crash. However, inspection of the safety belt revealed evidence of the beginning of webbing failure near the belt's attachment to the seat (arrow).

The occupant of the seat, restrained by the seat belt, received only minor injuries. Although his seat remained in place, he was allowed to flex forward, striking the forward bulkhead.

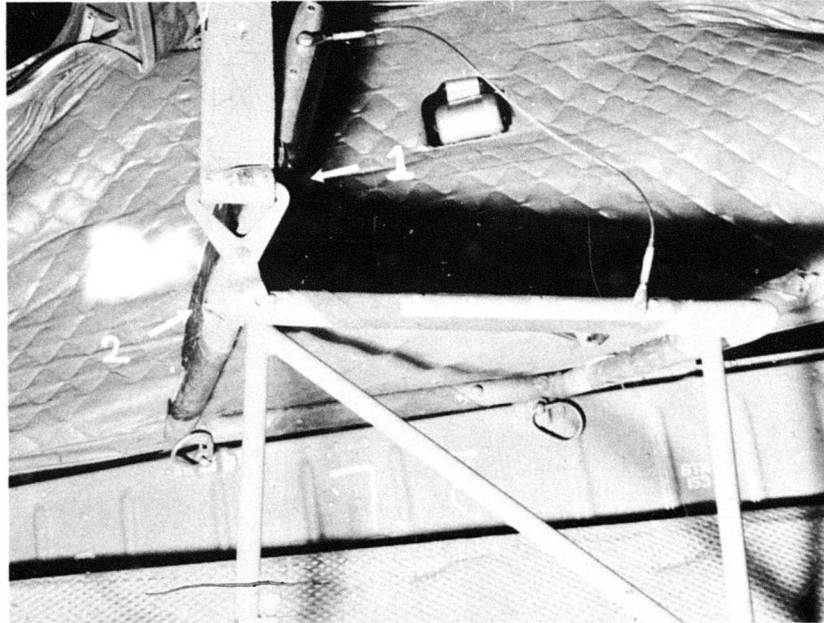

Fig. 39. Seat 2L in its normal position in the cabin. Both aisle anchorage buttons (attachments) were torn free, apparently because of the deceleration and upheaval of the cabin floor during the principal impact. The seat belt showed evidence of incipient webbing failure at its attachment to the seat (arrow). Both the left and the right brackets joining the seat pan and seat back were badly distorted and started to fail. (Arrow 2 indicates the right bracket; the left bracket is not shown.)

The occupant of this seat received only minor injuries.

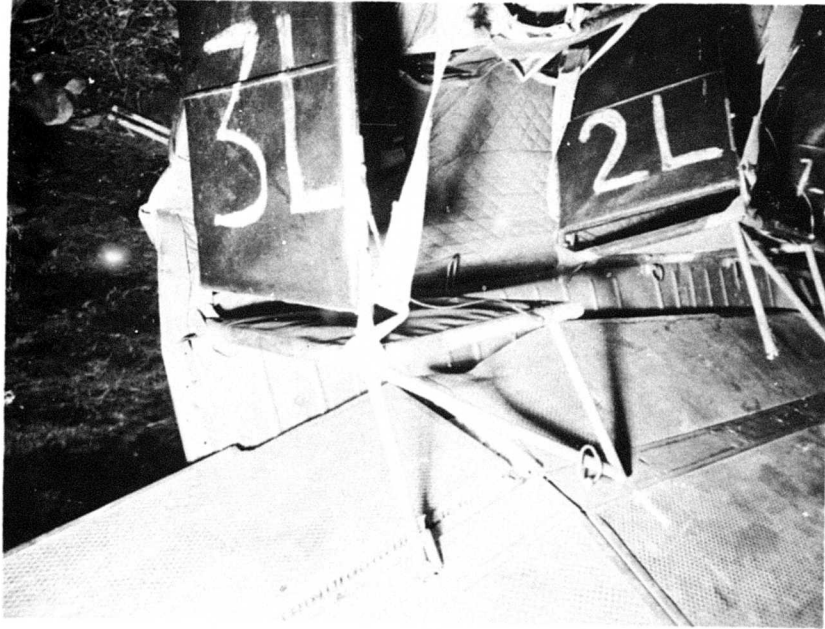

Fig. 40. Seat 3L remained intact except for the forward aisle attachment, which was torn free (arrow). The upheaval and separation of the cabin floor between the forward and rear aisle attachments were in the area where the left wheel collapsed upward into the fuselage during the principal impact.

The occupant of this seat received only minor injuries, although seated in the area of the cabin where the ceiling and wall structure was badly buckled and collapsed.

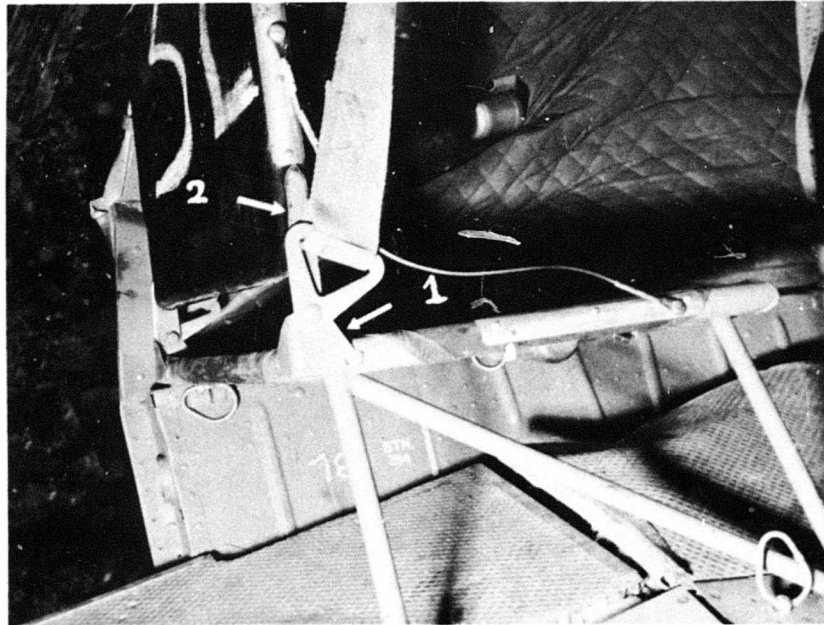

Fig. 41. The safety belt is anchored to the bracket attaching the seat back to the seat pan (arrow 1). The metal strap (arrow 2) attaching and hinging the seat back to the seat-pan bracket showed evidence of beginning to separate from the vertical seat-back support to which it was welded. Complete failure of the metal strap would have allowed the seat back to tear free from the seat pan.

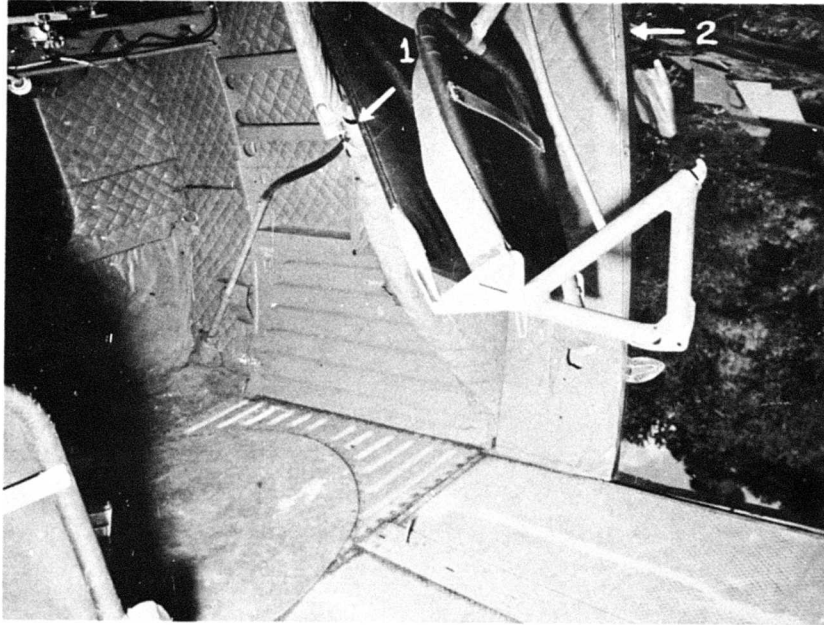

Fig. 42. Seat 4L was torn partially free, remaining attached only to the upper wall fitting. The vertical luggage compartment post, which was utilized as one of the seat attachments, failed completely (arrow 1). Simultaneously, the floor and lower wall attachments tore free and allowed the seat and the belted occupant to move forward, downward, and to the left while pivoting around the intact upper wall fitting. The occupant apparently struck the cabin wall and rear door frame (arrow 2); he sustained moderate injuries.



Fig. 43. Failure of the luggage compartment post utilized as one of the seat attachments is shown by arrows 1 and 2.



Fig. 44. Seat 1L remained completely intact and in its normal position in the cabin during the crash. However, both aisle floor attachments were distorted, and the safety belt revealed evidence of incipient failure at its anchorages to the seat pan.



Fig. 45. Both aisle floor attachments of seat 2L tore completely free. The seat was forced in a forward direction, partially "hinging" at its two wall attachments, which were badly distorted. The safety belt showed evidence of incipient failure near its attachment, and both the left and the right brackets joining the seat pan and the seat back were badly distorted (arrows 1 and 2).

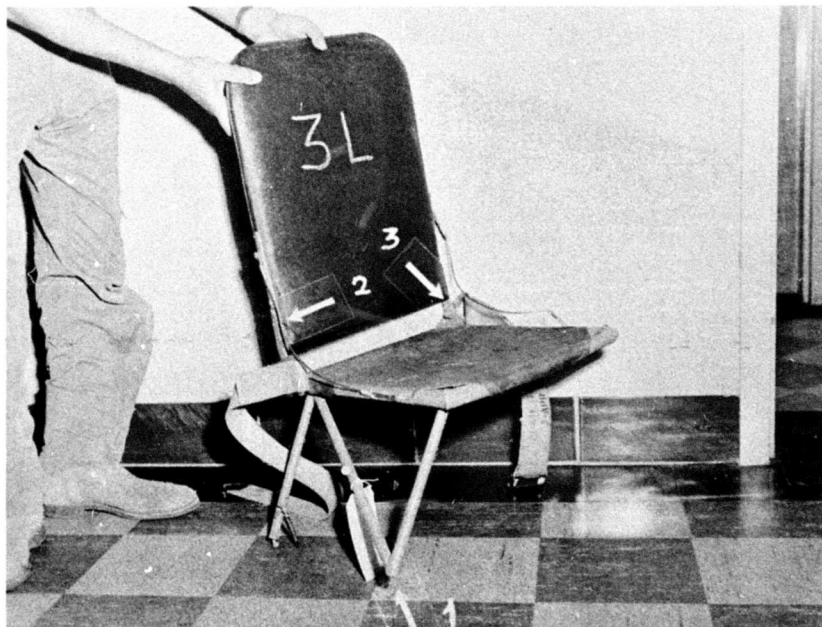

Fig. 46. The forward aisle attachment of seat 3L tore free (arrow 1); the other aisle and both wall attachments were badly distorted. The metal strap (arrows 2 and 3) attaching and hinging the seat back to the seat pan showed evidence of incipient failure. Both safety belt attachments were intact but distorted.

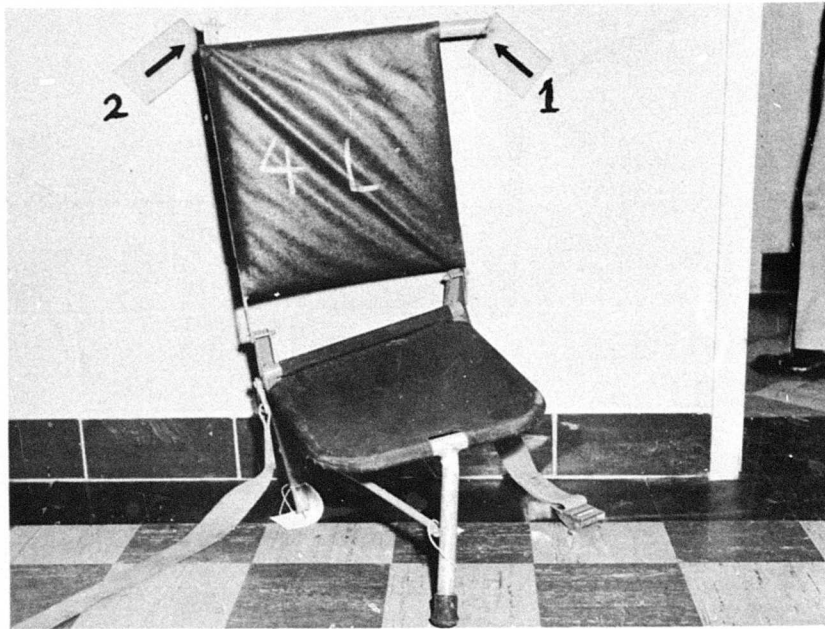

Fig. 47. Seat 4L was torn partially free, remaining attached by only the upper left wall fitting (arrow 1). The seat pan was distorted. Failure of the luggage compartment post allowed the upper right seat attachment (arrow 2) to tear free.



Fig. 48. Seat 1R was the only seat in which the safety belt, seat pan, seat back, and all seat anchorages remained completely intact. The occupant of this seat, who was restrained by his seat belt, received moderate injuries that were apparently caused by his striking his head and upper torso against the bulkhead separating the cockpit and the cabin.



Fig. 49. Seat 2R was severely damaged during the crash. The seat back was torn free from the seat pan because both of the metal straps joining and hinging the back to the pan (arrow 1) failed. Both aisle floor anchorages and the rear wall anchorage tore completely free; the forward wall fitting was badly distorted (arrow 2).

Failure of the metal strap caused the left anchorage of the safety belt to tear free (arrow 3) and the webbing to tear completely through at the right anchorage of the belt.

The occupant of this seat, although unrestrained during a major portion of the crash because of the complete failure of both his seat and his seat belt, received only moderate injuries.



Fig. 50. Seat 3R tore completely free because of failure of the wall and aisle floor anchorages. Failure of the metal straps that joined and hinged the seat back to the seat pan allowed the seat back to tear free from the seat pan. The safety belt failed in two places: (a) in the webbing (arrow 1) because of the cutting action of the serrations of the buckle cam, and (b) in the anchorage (arrow 2), which allowed the left-hand portion of the belt to tear free from the seat.

The occupant of this seat received severe injuries and had to be assisted from the wreckage. His injuries, consisting of a dislocation of the left hip and of moderate abrasions, were inflicted when he hurtled through the air following the simultaneous failure of his seat anchorages and safety belt.

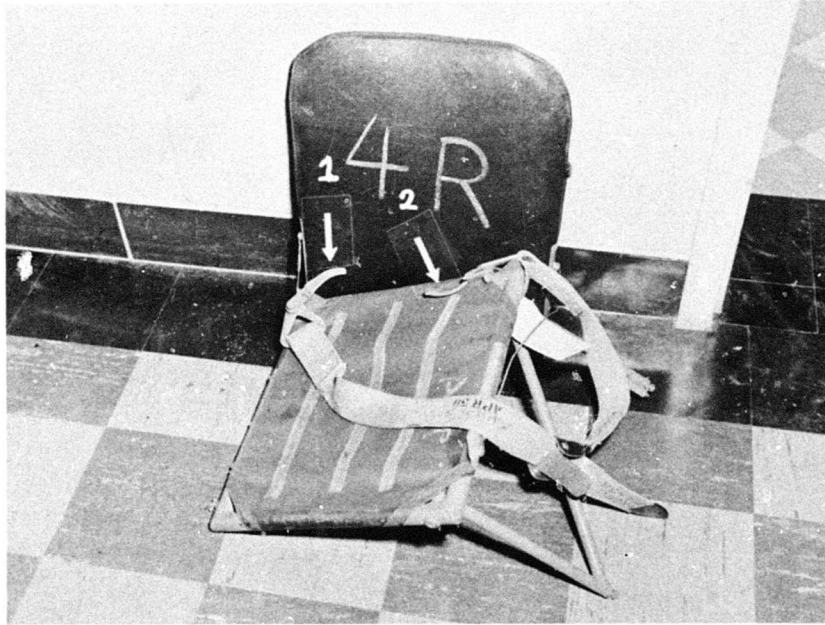

Fig. 51. Both the wall and the aisle floor anchorages of seat 4R remained intact although badly distorted. The seat back and both safety belt anchorages (arrows 1 and 2) tore completely free because of (a) failure of the metal straps hinging and joining the seat back and seat pan and (b) failures of the brackets attaching the seat belt anchorages to the seat pan.

The occupant of this seat sustained only minor injuries, although the failure of his safety belt allowed his body to hurtle forward and to the left across the aircraft cabin.

The difference in injury of this occupant from that of the person in seat 3R is indicative of the variations which may be expected when persons become "free missiles".

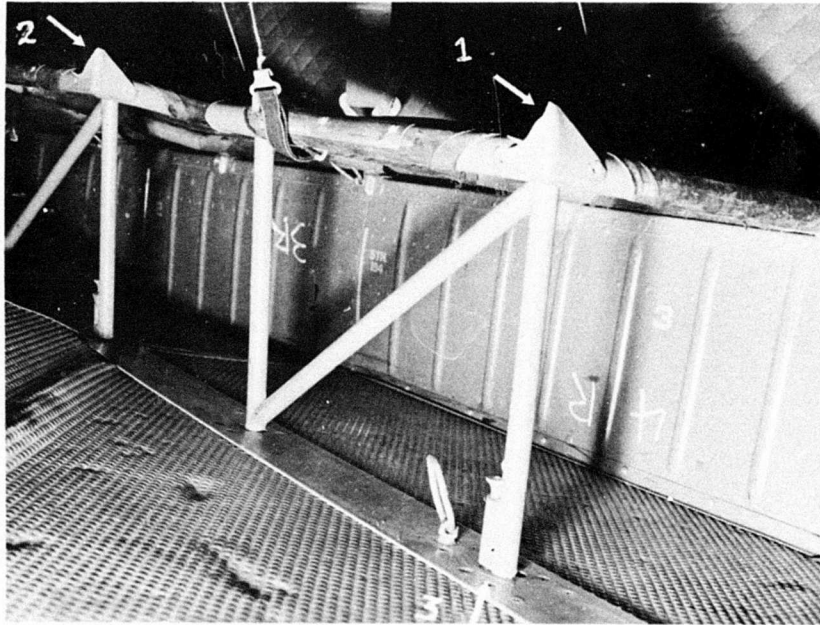

Fig. 52. Although torn completely free during the crash, seat 3R was placed in its normal position in the aircraft for this photograph.

Note the failure of the brackets of seats 4R and 3R (arrows 1 and 2), which serve as anchorages for the safety belt and the seat back. Failures of this type resulted in the safety belts and seat backs tearing completely free from two seats.

The type of attachment of the passenger seats to the floor is indicated by arrow 3.



Fig. 53. Seat 5R was unoccupied and folded up against the rear partition.

PRECEDING
PAGE BLANK

APPENDIX I

CRASH FORCE ANALYSIS

The data* used for calculating the principal mean deceleration in this Otter accident were:

Impact angle: 20 degrees
Horizontal velocity: 80 f. p. s.
Vertical velocity: 29 f. p. s.
Vertical deceleration distance (total): 1.25 ft.
Horizontal deceleration distance (principal impact): 5.75 ft.
Horizontal deceleration distance ("further" run-out): 50.25 ft.
Coefficient of friction: .9

Calculations using these data indicate that the mean horizontal deceleration was approximately 10G with a duration of .086 seconds. The mean vertical deceleration, of the same duration, was approximately 10.5G. The resultant of these is approximately 14.5G applied at an angle of about 40 to 50 degrees below, and 20 degrees to the left of the longitudinal axis of the aircraft. (Peak loads were undoubtedly in excess of these figures.)

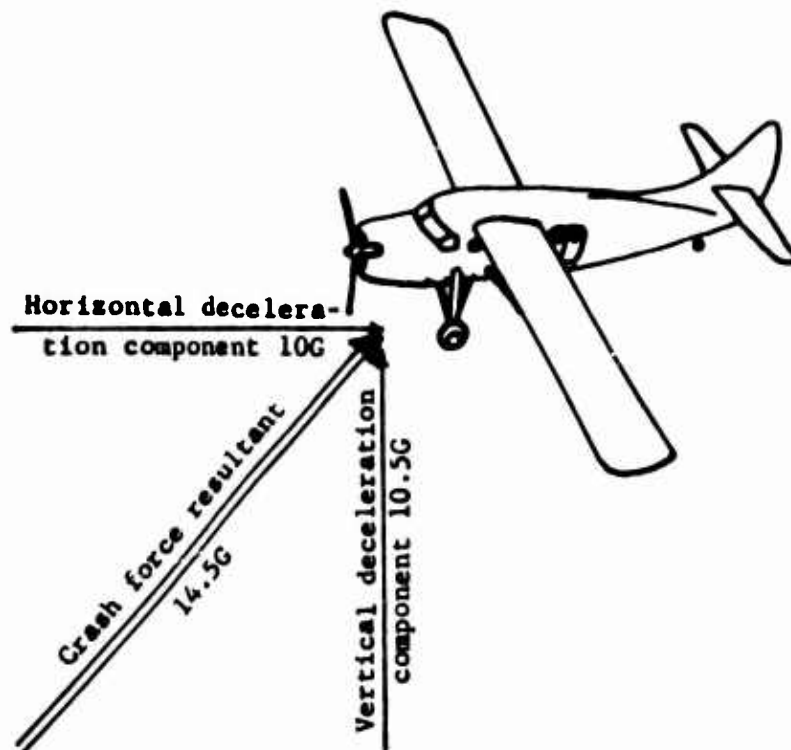

* All data were obtained from measurements and estimates at the crash site.

APPENDIX II

SUMMARY OF MEDICAL REPORTS

SEAT NO.	DEGREE OF INJURY	HEAD	UPPER TORSO
Pilot - L	Minor	1. Abrasion center forehead. 2. Scratch left cheek. 3. Curved scratch upper and lower lip.	
Copilot-R	Minor	1. Contusion under tip of chin.	
1L	Minor	1. Bruise left occiput.	
1R	Moderate	1. 4" laceration top of head.	2. Abrasion left flank.
2L	Minor	1. 1" laceration left side chin. 2. Contusions lower lip	
2R	Moderate	1. 1½" laceration top of head. 2. 1" laceration above left eye. Subconjunctival hemorrhage and periorbital hemorrhage (black eye) left.	3. 3" abrasion left anterior shoulder.
3L	Moderate	1. 2" laceration above right eye. 2. 1" laceration bridge of nose. 3. 1½" laceration upper lip. 4. Abrasions left temple and front of left ear.	5. Right chest soreness.
3R	Severe		1. 3" abrasion back of lower neck.
4L	Moderate	1. 2" laceration top of head. 2. 3" laceration right forehead.	
4R	Minor	1. Abrasions left forehead, cheek and chin. 2. Loss both upper first pre-molar teeth.	

LOWER TORSO	UPPER EXTREMITIES	LOWER EXTREMITIES
	4. Subungual hematoma left ring finger.	5. Abrasion left shin.
		2. Abrasions below knees - lateral aspect left leg; medial aspect right leg.
	2. Abrasions dorsum, right wrist.	3. Abrasions both knees.
3. Strained back (lower).		
	4. Abrasions knuckles, left hand.	5. Abrasions right shin.
	6. 3" scratch back of left hand.	
2. Abrasions and contusions left scrotum.		3. Dislocation left hip without fracture. 4. Abrasions and contusions medial side left thigh. 5. Abrasions right shin.
		3. Tear medial collateral ligament right knee.

**THIS REPORT HAS BEEN DELIMITED
AND CLEARED FOR PUBLIC RELEASE
UNDER DOD DIRECTIVE 5200.20 AND
NO RESTRICTIONS ARE IMPOSED UPON
ITS USE AND DISCLOSURE.**

DISTRIBUTION STATEMENT A

**APPROVED FOR PUBLIC RELEASE;
DISTRIBUTION UNLIMITED.**