

UNCLASSIFIED

AD NUMBER

AD825278

LIMITATION CHANGES

TO:

Approved for public release; distribution is unlimited.

FROM:

Distribution authorized to U.S. Gov't. agencies and their contractors; Critical Technology; DEC 1967. Other requests shall be referred to Air Force Aero Propulsion Laboratory, Attn: APIE-3, Wright-Patterson AFB, OH 45433. This document contains export-controlled technical data.

AUTHORITY

AFAPL ltr, 12 Apr 1972

THIS PAGE IS UNCLASSIFIED

AFAPL-TR-67-143

AD825278

EXPERIMENTAL DEMONSTRATION
OF
ENERGY STORAGE SUBSTATIONS
FOR
AIRCRAFT ACTUATION FUNCTIONS

C. W. Helsley, Jr., B. J. Call

LOS ANGELES DIVISION
NORTH AMERICAN ROCKWELL CORPORATION

FINAL TECHNICAL REPORT AFAPL-TR-67-143

DECEMBER 1967

STATEMENT IS UNCLASSIFIED

This document is subject to special export controls and each transmittal to foreign governments or foreign nationals may be made only with prior approval of

Air Force Aero Propulsion Laboratory
Research and Technical Division
Air Force Systems Command
Wright-Patterson Air Force Base, Ohio

attw: APIE-3
BPSN 6(638128-62405214)

D D C
JAN 19 1968

NOTICES

Foreign announcement and distribution of this report is not authorized. The distribution of this report is limited because it contains technology identifiable with items on the strategic embargo lists excluded from export or re-export under U.S. Export Control Act of 1949 (63STAT.7), as amended (50 U.S.C. App. 2020-2031), as implemented by AFR 400-10.

When Government drawings, specifications, or other data are used for any purpose other than in connection with a definitely related Government procurement operation, the United States Government thereby incurs no responsibility nor any obligation whatsoever; and the fact that the Government may have formulated, furnished, or in any way supplied the said drawings, specifications, or other data, is not to be regarded by implication or otherwise as in any manner licensing the holder or any other person or corporation, or conveying any rights or permission to manufacture, use, or sell any patented invention that may in any way be related thereto.

Copies of this report should not be returned to the Research and Technology Division unless return is required by security considerations, contractual obligations, or notice on a specific document.

| | |
|-----------------|--|
| ACQUISITION | |
| CFSTI | IN THE SECTION <input checked="" type="checkbox"/> |
| ORC | |
| U.S. GOVERNMENT | |
| JUSTICE | |
| BY | |
| DATE | |
| 2 | |

EXPERIMENTAL DEMONSTRATION
OF
ENERGY STORAGE SUBSTATIONS
FOR
AIRCRAFT ACTUATION FUNCTIONS

C. W. Helsley, Jr., B. J. Call

LOS ANGELES DIVISION
NORTH AMERICAN ROCKWELL CORPORATION

FOREWORD

This is the final technical report covering a Phase II effort on research and development on the flywheel as an energy storage device for use in the performance of aircraft actuation functions. The Phase I effort investigated energy storage concepts for aircraft actuation functions, and exhaustively analyzed all pertinent design features of the flywheel.

This Phase II effort is an experimental demonstration program for the operation of aircraft flight control and utility function simulators using energy storage substations which have flywheels as the principal energy storage element. Both the Phase I and Phase II programs were conducted by North American Rockwell Corporation, Los Angeles Division, under USAF Contract AF33(615)-2971, Project No. 8128, Task No. 2, and USAF Contract AF33(615)-5173, Project No. 3145 and Task No. 314528, respectively.

Initial Phase I effort began 1 July 1965. The period of effort which this report documents is from 1 July 1966 through 31 December 1967. This program was monitored by Mr. R. Smith (APIE-3), of the Air Force Aero Propulsion Laboratory, RTD, Wright-Patterson Air Force Base, Ohio. All effort was conducted at North American Rockwell Corporation, Los Angeles Division, under the direction of Mr. C. W. Helsley, Jr. as Program Manager, assisted by Mr. B. J. Call.

This report is identified as North American Rockwell Corporation Report No. NA-67-964, pending USAF approval. Publication of this technical report does not constitute Air Force approval of the report's findings or conclusions. It is published only for the exchange and stimulation of ideas.



Paul E. Peko, Maj USAF
Br Chief, Propulsion and Power
Aerospace Power Division

ABSTRACT

There are two principal uses for flywheels: To create precessional forces (such as gyroscopes) and to store kinetic energy. This program demonstrated the use of optimized energy storage flywheels for the purpose of supplying peak energy demands in aircraft flight control and utility actuation function duty cycles.

Three simulators were used. One was a tilt table for investigation of precessional loads on bearings. Another was the XB-70 landing gear simulator for demonstration of both hydraulic and mechanical power extraction from flywheels in the performance of intermittent type of aircraft actuation duty cycles. A third simulator demonstrated 1,500 hours of aircraft flight control operation, wherein a bank of three XB-70 elevons were supplied one third of their peak hydraulic flow from a motor-pump driven by a flywheel. This test demonstrated 300 flights of 5 hours each.

These endurance test demonstrations were the second phase in a two-phase program. Phase I effort established analytically that very substantial weight savings can be made in aircraft through the use of energy storage substations in secondary power subsystems.

The three simulators were driven by three identical energy storage substations. The only failures that occurred to the substations throughout the testing were associated with rotary seals and support bearings for the flywheels, and motor-pump rotating groups.

The program very successfully demonstrated the operating characteristics and the feasibility of using flywheel energy storage substations in the accomplishment of aircraft actuation functions. The program also verified the validity of the weight saving estimates made in Phase I.

TABLE OF CONTENTS

| Section | | Page |
|---------|--|------|
| I | GENERAL | 1 |
| II | ENERGY STORAGE SUBSTATION | 4 |
| | A. Flywheel Description | 4 |
| | B. Gearbox Description | 12 |
| | C. Motor-Pump Description | 12 |
| | D. Substation Weight | 21 |
| III | TILT TABLE SIMULATOR | 25 |
| | A. Simulator | 25 |
| | B. Precessional Load Test Spectrum | 25 |
| | C. Tilt Table Simulator Testing | 38 |
| | D. Tilt Table Simulator Test Conclusions | 65 |
| IV | INTERMITTENT DUTY CYCLE SIMULATOR | 69 |
| | A. Basic Test Objectives | 69 |
| | B. Hydraulic Power Extraction System and Endurance Test | 69 |
| | C. Mechanical Power Extraction System Endurance Test | 88 |
| | D. Intermittent Duty Cycle Simulator Test Conclusions | 98 |
| V | CONTINUOUS DUTY CYCLE SIMULATOR | 100 |
| | A. Flight Control Application | 100 |
| | B. Simulator | 100 |
| | C. Endurance Test | 103 |
| | D. Disassembly and Inspection | 122 |
| | Flywheel Housing | 122 |
| | Flywheel | 122 |
| | Carbon Seals | 126 |
| | Splined Quill Shaft | 126 |
| | Bearings | 129 |
| | Gearbox | 129 |
| VI | PROGRAM SUMMARY AND CONCLUSIONS | 155 |

LIST OF ILLUSTRATIONS

| Figure No. | Title | Page |
|------------|---|------|
| 1. | Energy Storage Substation | 5 |
| 2. | Energy Storage Substation | 6 |
| 3. | Aerodynamic Losses | 9 |
| 4. | Flywheel Assembly | 10 |
| 5. | Flywheel Assembly | 11 |
| 6. | Gearbox | 13 |
| 7. | Manual Motor-Pump | 16 |
| 8. | Automatic Motor-Pump | 17 |
| 9. | Prototype (Manual) Motor-Pump Configuration | 18 |
| 10. | Prototype (Manual) Motor-Pump Control Configuration | 19 |
| 11. | Automatic Motor-Pump Control Configuration | 20 |
| 12. | Motor-Pump Performance | 22 |
| 13. | Hydraulic Motor Schematic Diagram | 23 |
| 14. | Tilt Table Simulator | 26 |
| 15. | Schematic - Energy Storage Substation Tilt Table | 27 |
| 16. | Time Exceedance Curve | 32 |
| 17. | Time Exceedance Curve | 33 |
| 18. | Time Exceedance Curve | 34 |
| 19. | Time Exceedance Curve | 35 |
| 20. | Time Exceedance Curve | 36 |
| 21. | Time Exceedance Curve | 37 |
| 22. | Vibration Trace | 41 |
| 23. | Vibration Analysis | 42 |
| 24. | Destroyed Motor-Pump | 44 |
| 25. | Tilt Table Test Oscillograph Record | 56 |
| 26. | Tilt Table Test Oscillograph Record | 64 |
| 27. | Spring System Schematic | 67 |
| 28. | Hydraulic Power Extraction System | 70 |
| 29. | Mechanical Power Extraction System | 71 |
| 30. | Schematic - Energy Storage Substation Intermittent Duty Cycle Simulator Hydraulic and Mechanical Power Extraction | 72 |
| 31. | Installation - Energy Storage Substation Landing Gear Simulator | 74 |
| 32. | Simulated Airload on Landing Gear | 75 |
| 33. | Intermittent Duty Simulator - Panoramic View Showing Airload Cylinder | 76 |
| 34. | Intermittent Duty Simulator - Hydraulic Installation | 77 |
| 35. | Intermittent Duty Simulator - Hydraulic Installation Closeup | 78 |
| 36. | Intermittent Duty Simulator - Energy Storage Substation Closeup | 79 |
| 37. | Intermittent Duty Simulator - Energy Storage Substation Closeup (Front View) | 80 |
| 38. | Landing Gear (Hydraulic) Oscillographic Record | 86 |
| 39. | Mechanical Hinge | 89 |

LIST OF ILLUSTRATIONS

| Figure No. | Title | Page |
|------------|--|------|
| 40. | Clutch and Brake Assembly | 90 |
| 41. | Landing Gear Kinematics | 92 |
| 42. | Landing Gear (Mechanical) Oscillograph Record | 96 |
| 43. | Schematic - Energy Storage Substation Continuous Duty Cycle Simulator | 101 |
| 44. | Continuous Duty Cycle Simulator | 102 |
| 45. | Continuous Duty Cycle Test Oscillograph Record | 106 |
| 46. | Continuous Duty Cycle Test Oscillograph Record | 107 |
| 47. | Oscillograph Record With Expanded Ordinate Scale | 108 |
| 48. | Average Substation Temperature | 118 |
| 49. | Flywheel Absolute Pressure | 119 |
| 50. | Continuous Duty Endurance Test Flywheel Assembly | 123 |
| 51. | Closeup of Flywheel Housing | 124 |
| 52. | Flywheel After Continuous Duty Cycle Endurance Test | 125 |
| 53. | Flywheel Seal Mating Rings (Relapped Prior to 1,339.9 Hr Run) | 127 |
| 54. | Flywheel Shaft Seal | 128 |
| 55. | Flywheel - Gearbox Quill Shaft | 130 |
| 56. | Inboard and Outboard Flywheel Bearings | 131 |
| 57. | Service Pump Group Drive Wear | 132 |
| 58. | Gearbox and Service Pump Group Disassembled | 133 |
| 59. | View of Gearbox Half From Motor-Pump Side | 134 |
| 60. | View of Gearbox Half From Flywheel Side | 135 |
| 61. | Gearbox Spline - Input From Motor-Pump | 136 |
| 62. | Pinion Gear and Support Bearing | 137 |
| 63. | Comparison of High Speed Support Bearings | 139 |
| 64. | Closeup of Motor-Pump Driven Gear | 140 |
| 65. | Motor-Pump Driven Gear Tooth Magnified | 141 |
| 66. | Gerotor Vacuum Pump | 142 |
| 67. | Gerotor Lube Pump | 143 |
| 68. | Gerotor Scavenge Pump | 144 |
| 69. | Disassembled Motor-Pump | 145 |
| 70. | Motor-Pump Kidney Port Wear | 146 |
| 71. | Motor-Pump Piston Barrel Valving Surface Wear | 147 |
| 72. | Motor-Pump Wobble Plate | 148 |
| 73. | Closeup of Wobble Plate Erosion | 149 |
| 74. | Motor-Pump Control Actuator Ball Joint | 150 |
| 75. | Motor-Pump Piston Slippers | 152 |
| 76. | Enlarged View of Slipper Erosion | 153 |
| 77. | Motor-Pump Shift Spool Erosion | 154 |

LIST OF TABLES

| Table No. | Title | Page |
|-----------|---|------|
| I | Flywheel Geometry for an Optimized Disk (Approximately Constant Stress) (Material - Steel) | 7 |
| II | Gearbox Itemized Parts List | 14 |
| III | Tilt Table Test Time and Precessional Rate Requirements | 28 |
| IV | Pitch Rate Duty Cycles | 30 |
| V | Roll Rate Duty Cycles | 31 |
| VI | Tilt Table Endurance Test Spectrum | 39 |
| VII | Tilt Table Simulator Test Data | 46 |
| VIII | Tilt Table Test Results Summary | 55 |
| IX | Tilt Table Simulator Test Data (Substation No. 2) | 60 |
| X | Tilt Table Simulator Test Data (Substation No. 1) | 63 |
| XI | Computed Bearing Forces | 66 |
| XII | Intermittent Duty Cycle Simulator Test Data (Hydraulic Power Extraction) | 83 |
| XIII | Intermittent Duty Cycle Endurance Test Results Summary | 87 |
| XIV | Intermittent Duty Cycle Simulator Test Data (Mechanical Power Extraction) | 95 |
| XV | Mechanical Power Extraction Endurance Test Results Summary | 97 |
| XVI | Basic Duty Cycle Applications for Endurance Testing of Energy Storage Substations (Applicable to B-70 Class Aircraft) | 104 |
| XVII | Generalized Control System Duty Cycles (Including B-70 Class Aircraft) | 105 |
| XVIII | Continuous Duty Cycle Test Data | 110 |

Section I

GENERAL

This report covers the Phase II activities of a program to demonstrate the overall feasibility, in terms of performance, reliability and weight, of energy storage substations employing a flywheel as the basic energy storage device. The energy storage concept embraces an approach wherein the energy represented by the surplus power available in the secondary power subsystem during a greater portion of a typical air vehicle mission is stored in one or more substations. The substations are located as close as possible to the point of power use.

It had been shown during Phase I studies (refer to AFAPL TR 66-29) that this approach offered the possibility of saving significant amounts of weight. Therefore, the basic function of this Phase II program was to demonstrate the reliability of the flywheel and to more accurately evaluate the potential weight savings. This demonstration program was also intended to show the dynamic response characteristics of the energy storage substation when used in flight control-type systems, and the durability of the device when used in both flight control and utility applications.

As previously indicated, the flywheel is the "heart" of the system. It is the device which stores the energy through increased rotational speed (and increased internal stress) and gives up energy by slowing down. For this reason, before discussing the demonstration program, it would be well to review some of the flywheel characteristics which were used.

1. The flywheel was made from a high endurance limit (140,000 psi) stress steel which was determined in Phase I to be the most satisfactory material currently available.
2. The cross section of the flywheel was of the so-called "optimized disc" shape. The sides of the disc were double reversed exponential curves thicker at the hub than at the tip. This cross section approached as closely as possible the ultimate, but unattainable, objective of uniform stress throughout the material.
3. At a given stress level, the "optimized disc" configuration has the same specific energy storage (i.e., energy stored per pound of weight) irrespective of diameter. This means that a large diameter, thin, and slow-turning flywheel of the "optimized disc" configuration will store the same energy at the same weight as a small diameter "chunky" flywheel turning at high rotational speed.
4. In addition to its energy-storage characteristics, the flywheel is a gyroscope. This means that when mounted on a maneuvering platform (such as an air vehicle) which maneuvers in three planes, the flywheel will generate significant and sometimes destructive precessional loads in its support bearings.

5. All other things being equal, the precessional loads are a function of flywheel diameter and bearing support spacing. The smaller the diameter and the wider the support spacing the lower the precessional loads. Therefore, to reduce precessional loads, a flywheel should be of as small a diameter and as "chunky" a cross section as possible.
6. Windage losses are a major determinant of flywheel energy storage effectiveness. All other things being equal, flywheel windage losses are a function of the density of the gas surrounding the flywheel and the diameter of the flywheel. The less dense the gas and the smaller the flywheel diameter the less the losses.

As a basis for setting up the demonstration tests, typical aircraft actuation functions have been divided into two general classifications which are identified as "intermittent" and "continuous." Functions fitting the "intermittent" classification are defined as those in which short periods of peak power demand are followed by long quiescent periods of zero power demand. The speed brake and flap systems of most airplanes fit this description as do the landing gear and rocket package extension systems. On the other hand the "continuous" classification is defined as one in which a continuous low level of power demand exists (usually less than 10 percent rated) upon which is superimposed intermittent periods of high power demand (approaching 100 percent rated). Functions fitting this classification are frequently designated "flight control" type and are exemplified by the operation of ailerons, elevons, rudders, air inlet control systems, etc. It then follows that the duty cycles associated with these two functional classifications establish design criteria sufficiently diverse that separate demonstrations were warranted.

For the purposes of this program, the main landing gear extend and retract functions and the flight control elevon actuation function of the XB-70 aircraft were selected as best exemplifying the "intermittent" and "continuous" applications respectively for the endurance test demonstrations. Three simulators were used in the accomplishment of these objectives. These are:

1. A Tilt Table
2. A Flight Control Simulator
3. A Landing Gear Simulator

Each of the above units is described subsequently in detail; however, it is significant to point out that due to careful selection of functions to be demonstrated and tests to be run, it was possible to use essentially the same type of energy storage substation assembly for each of the three demonstrations.

The planned program of testing was as follows:

| | |
|------------------------|-------------|
| Tilt Table Testing | 100 hours |
| Flight Control Testing | 1,500 hours |

Landing Gear (hydraulic
power extraction) 10,000 cycles

Landing Gear (mechanical
power extraction) 10,000 cycles

Tilt table testing was essentially completed prior to starting either the intermittent or continuous duty cycle endurance testing. These first tests established several important facts and cleared up many areas where only projected thinking was available, on which to base operational procedures for the simulators.

Section II

ENERGY STORAGE SUBSTATION

The basic function of the energy storage substation demonstrated during this program was to store the surplus energy available in an aircraft hydraulic system during periods of steady-state (low) demand and make it available for use by the power using (output) device during periods of peak demand. Of the four demonstration tests conducted, three extracted power from the hydraulic system for storage purposes and returned it to the hydraulic system on demand. The fourth (i.e., the mechanical intermittent duty test) also extracted the power for storage from the hydraulic system but delivered the demand power mechanically in the form of rotating shaft power.

In the interests of simplicity the substation designed for this program was set up so that, with only slight modifications, it could be adapted to any of the four demonstrations. The resulting substation is shown in figure 1 and the photograph of figure 2. All three units built were essentially identical except for interchanging different motor-pump units. Figure 1 shows a New York Air Brake motor-pump installed whereas figure 2 shows a Vickers motor.

As can be seen in figure 1 the energy storage substation consists of a flywheel (to store energy), a hydraulic motor-pump (acting as a motor to keep the flywheel wound up and acting as a pump to extract energy on demand), a gearbox (to couple the motor-pump to the high-speed flywheel and to provide a power takeoff pod for the extraction of mechanical power), and a service pump group (to lubricate and scavenge the substation and evacuate the flywheel case). Each of these components is discussed in detail in the following paragraphs.

A. FLYWHEEL DESCRIPTION

The flywheels for all of the energy storage substations were purposely designed the same, even though optimization would have caused them to each be of different capacities. Identical flywheels were chosen in the interest of overall program effectiveness. First, they would be essentially interchangeable on the simulators; and second, a proper evaluation of their true capabilities could be more easily made if disruptive factors resulting from size and configuration differences did not enter into the analysis of data.

Table I is a tabulation of the flywheel geometry and characteristics. It was created by using direct ratios of the flywheels computed and tabulated during the Phase I program.

Total kinetic energy was determined from the values of required useful kinetic energy and speed reduction. The following relationship was used:

$$KE_{\text{Total}} = KE_{\text{Useful}} \frac{(\text{Maximum Speed})^2}{(\text{Maximum Speed})^2 - (\text{Minimum Speed})^2}$$

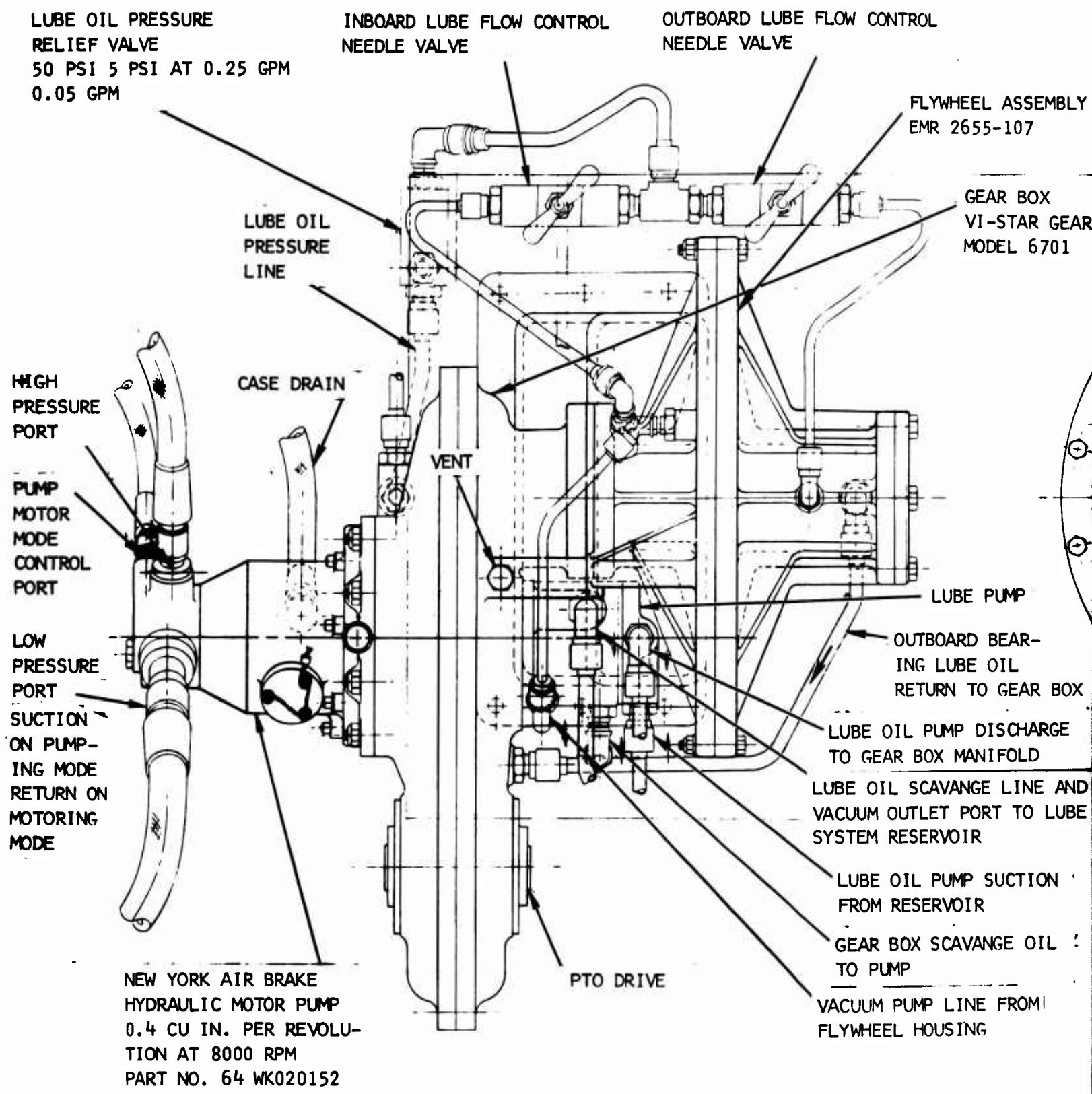

A

LUBE FLOW CONTROL
VALVE

FLYWHEEL ASSEMBLY
EMR 2655-107

GEAR BOX
VI-STAR GEAR CO
MODEL 6701

LUBE PUMP

OUTBOARD BEAR-
ING LUBE OIL
RETURN TO GEAR BOX

LUBE OIL PUMP DISCHARGE
TO GEAR BOX MANIFOLD

LUBE OIL SCAVANGE LINE AND
VACUUM OUTLET PORT TO LUBE
SYSTEM RESERVOIR

LUBE OIL PUMP SUCTION
FROM RESERVOIR

GEAR BOX SCAVANGE OIL
TO PUMP

VACUUM PUMP LINE FROM
FLYWHEEL HOUSING

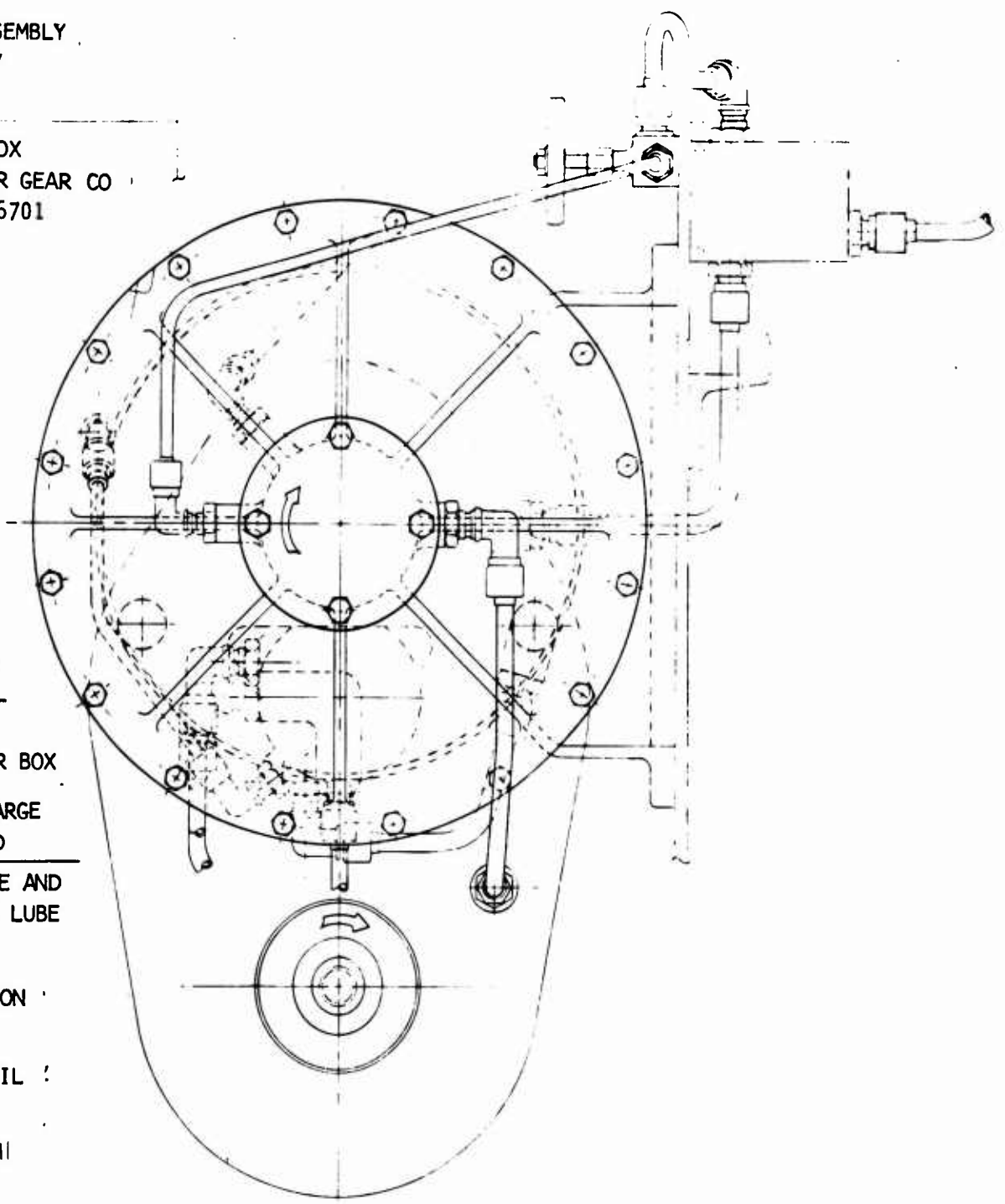

Figure 1. Energy Storage Substation

B

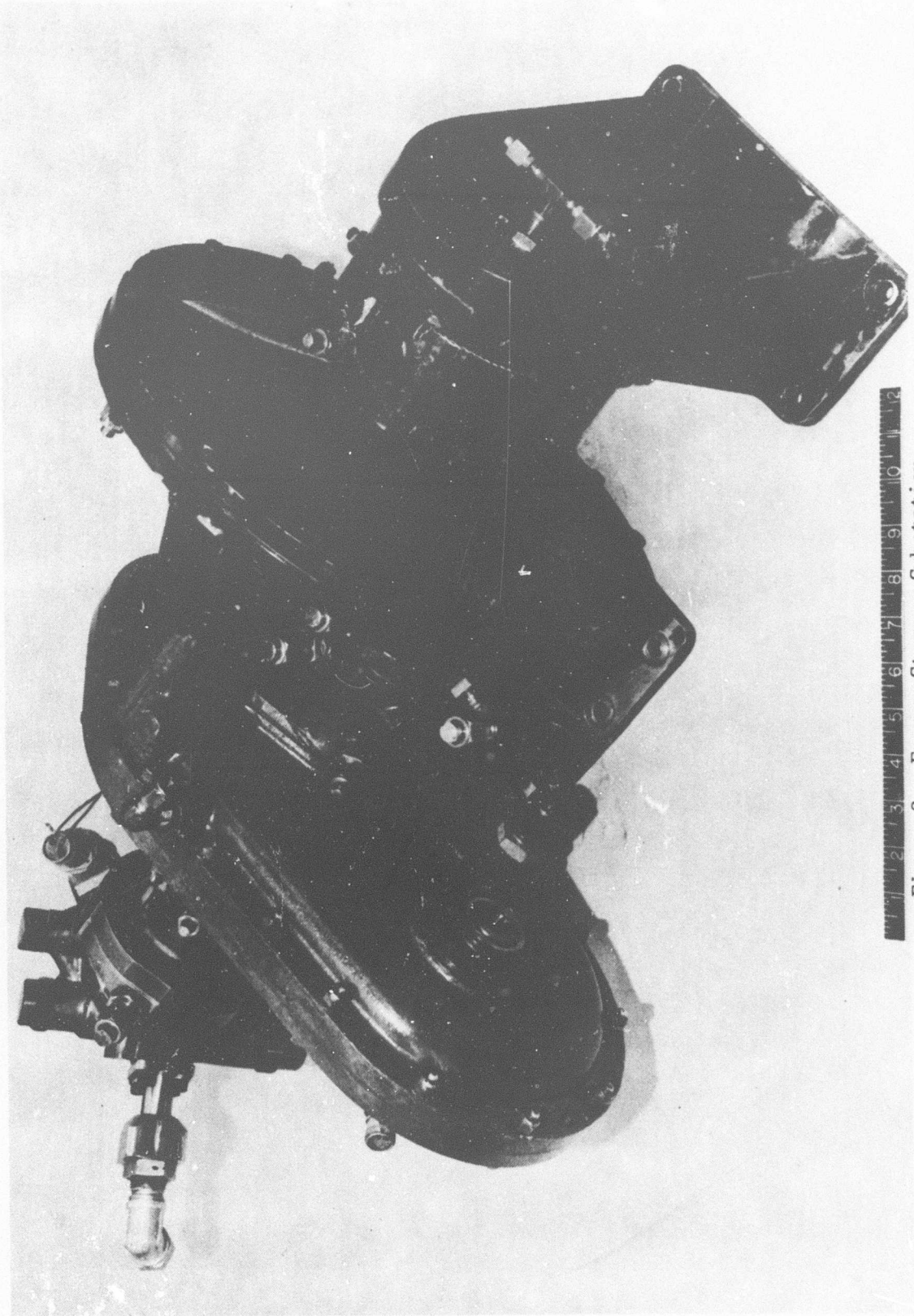

Figure 2. Energy Storage Substation

BLANK PAGE

Table I

FLYWHEEL GEOMETRY FOR AN OPTIMIZED DISK (APPROXIMATELY CONSTANT STRESS)
(MATERIAL - STEEL)

| Position | Radius | Thickness (T) | T/2 | S (Tangential) | S (Radial) |
|----------|--|---------------|------|---|------------|
| | Outside Radius (R) = 5.000 inches | | | Design Stress (S) = 97,222 lb/sq in. | |
| | Poissons Ratio (MU) = 0.300 | | | Density (RH0) = 0.285 lb/cu in. | |
| | Kinetic Energy (KE) = 4,000,000 in.-lb | | | Weight (WT) = 14.058 lb | |
| | Angular Velocity (OMEGA) = 5,487 rad/sec | | | KE/WT = 284,538 in.-lb/lb | |
| | Rad of Gyration (K) = 2.702 inch | | | Moment of Inertia (I) = 0.265 lb-in.-sq sec | |
| 1 | 5.000 | .113 | .056 | 69,240 | 0 |
| 2 | 4.750 | .148 | .074 | 76,355 | 23,692 |
| 3 | 4.500 | .192 | .096 | 81,519 | 40,901 |
| 4 | 4.250 | .246 | .123 | 85,311 | 53,591 |
| 5 | 4.000 | .311 | .155 | 88,126 | 62,926 |
| 6 | 3.750 | .386 | .193 | 90,238 | 69,966 |
| 7 | 3.500 | .473 | .236 | 91,838 | 75,300 |
| 8 | 3.250 | .572 | .286 | 93,062 | 79,379 |
| 9 | 3.000 | .681 | .340 | 94,006 | 82,526 |
| 10 | 2.750 | .801 | .400 | 94,740 | 84,971 |
| 11 | 2.500 | .928 | .464 | 95,313 | 86,883 |
| 12 | 2.250 | 1.061 | .530 | 95,765 | 88,388 |
| 13 | 2.000 | 1.195 | .598 | 96,120 | 89,573 |
| 14 | 1.750 | 1.328 | .664 | 96,401 | 90,508 |
| 15 | 1.500 | 1.454 | .727 | 96,621 | 91,242 |
| 16 | 1.250 | 1.572 | .786 | 96,792 | 91,813 |
| 17 | 1.000 | 1.674 | .837 | 96,993 | 92,249 |
| 18 | 0.750 | 1.758 | .879 | 97,019 | 92,569 |
| 19 | 0.500 | 1.822 | .911 | 97,085 | 92,788 |
| 20 | 0.250 | 1.860 | .930 | 96,123 | 92,916 |
| 21 | -0.000 | 1.874 | .937 | 97,136 | 92,958 |

The useful kinetic energy was established from the duty cycle required of the simulators, and the speed reduction was established by determining the minimum speed that could be tolerated by the pump and still meet the flow requirements.

Having established a total kinetic energy requirement from the foregoing it was then necessary through sizing a number of flywheels to make a weight and trade-off study of windage losses, precessional loads resulting from bearing spacing, housing weight, housing design, and general space and mounting provisions.

As a result of the above analysis, it was found that a 12-inch diameter flywheel was the most efficient in terms of energy storage versus weight at 52,400 rpm when considering the flywheel alone. However, this was not necessarily true when considering the overall flywheel assembly consisting of the flywheel, its housing, seals, and bearings. The analysis indicated that the large OD and relatively slender cross section of the 12-inch diameter flywheel when compared to a lesser diameter "chunkier" flywheel led to disproportionately large windage losses and placed greater demands on the bearings to resist precessional loads (refer to item 5, page 2). At the same time, the "slender" flywheel with a given bearing support spacing has a lesser inherent shaft stiffness. The weight saved in the slender flywheel was more than offset by increased weight in the housing and bearings; therefore, the present 10-inch diameter flywheel was selected as most nearly approaching optimum for the conditions. The 10-inch diameter selected could have been operated at 6,584 radians/second without exceeding 140,000 psi tensile stress; however, in consideration of the interrelated and sometimes conflicting requirements for specific energy storage, windage loss, and bearing life, operation at 5,487 radians/second (i.e. 52,400 rpm or 97,222 psi tensile stress) was selected.

The flywheel was mounted in ball bearings with features generally as follows:

- 25 mm bore (.9843 in.)
- 2.0472 outside diameter
- 17 mm width
- 11/32 dia ball (11 each bearing) single ball row, with angular contact and outer race riding cage, light series

The flywheel shroud was contoured to fit the flywheel exponential shape with a uniform clearance of 1/8 inch, thus reducing aerodynamic losses. To further reduce aerodynamic losses, the shroud was evacuated. Figure 3 is a plot of the horsepower losses versus vacuum. Rotary carbon seals were used between the evacuated flywheel and its bearings.

A cross-sectional drawing of the flywheel in its housing is shown in figure 4. Figure 5 is a photograph of one of the disassembled units after 34.5 hours of testing.

FLYMEEL WINDAGE LOSSES DUE TO HOUSING ATMOSPHERE
(10-INCH DIAMETER FLYMEEL, ROTATING AT 52,400 RPM)

$$\text{POWER (IN.-LB/SEC)} = .073 \times \rho \times \omega^3 \times R^5 (\mu/\rho\omega R^2)^{1/5}$$

ρ = DENSITY, (LB-SEC²/IN.⁴)

ω = ANGULAR VELOCITY, (RAD/SEC)

R = RADIUS, IN.

μ = ABSOLUTE VISCOSITY, LB-SEC/IN.²

$\mu = 2.604 \times 10^{-9}$ (LB-SEC/IN.²)

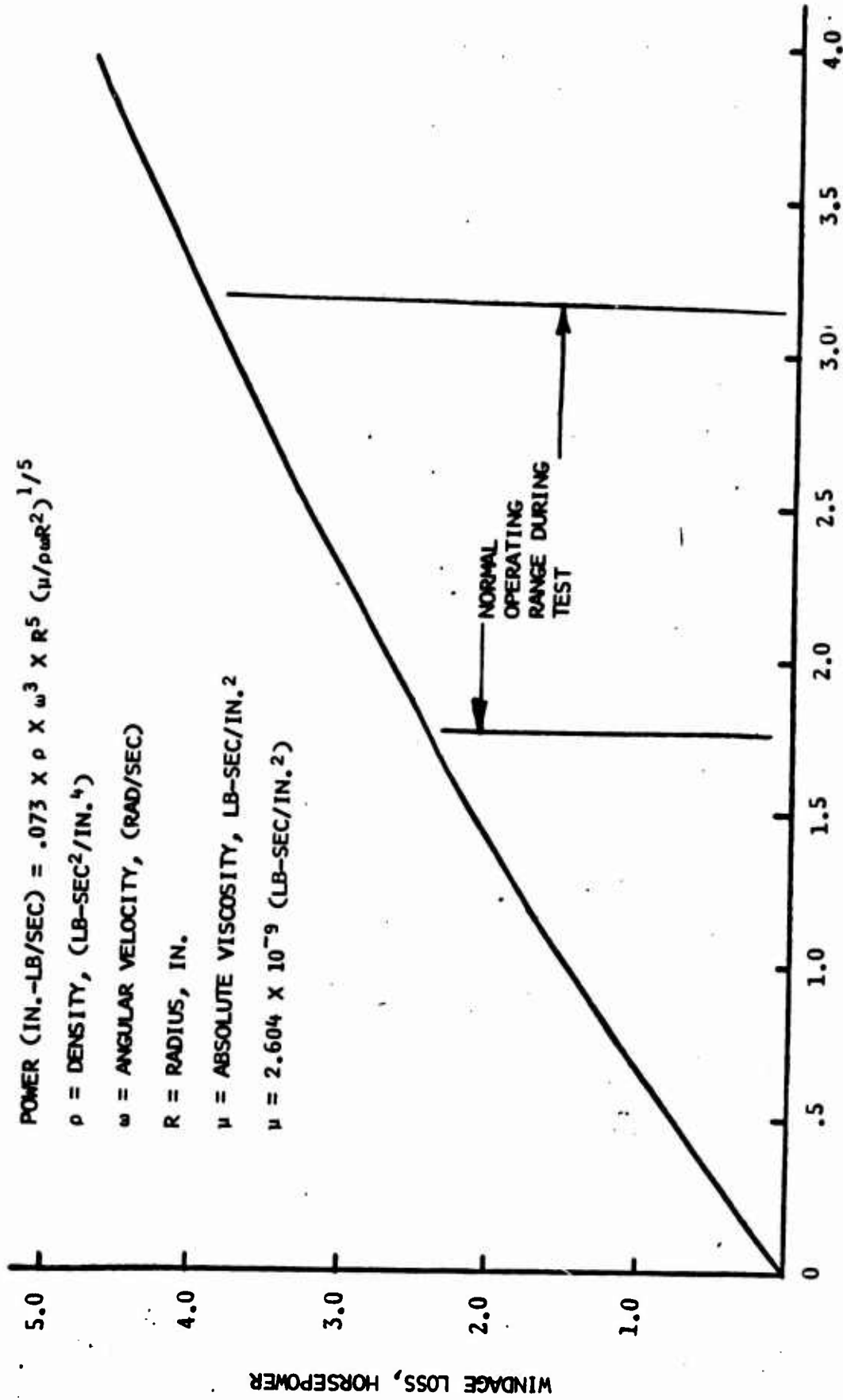

ABSOLUTE PRESSURE, CENTIMETERS OF MERCURY

Figure 3. Aerodynamic Losses

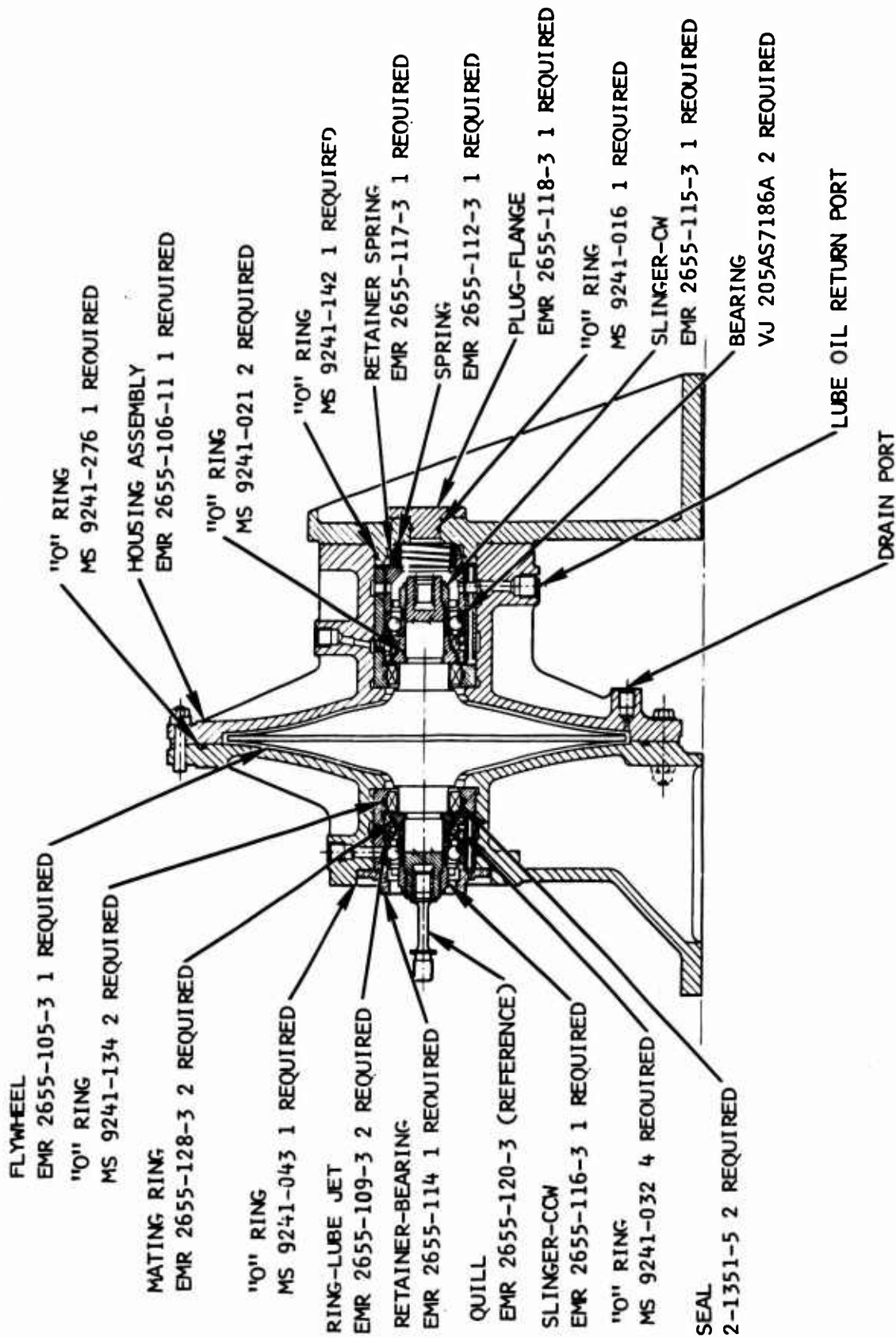

Figure 4. Flywheel Assembly

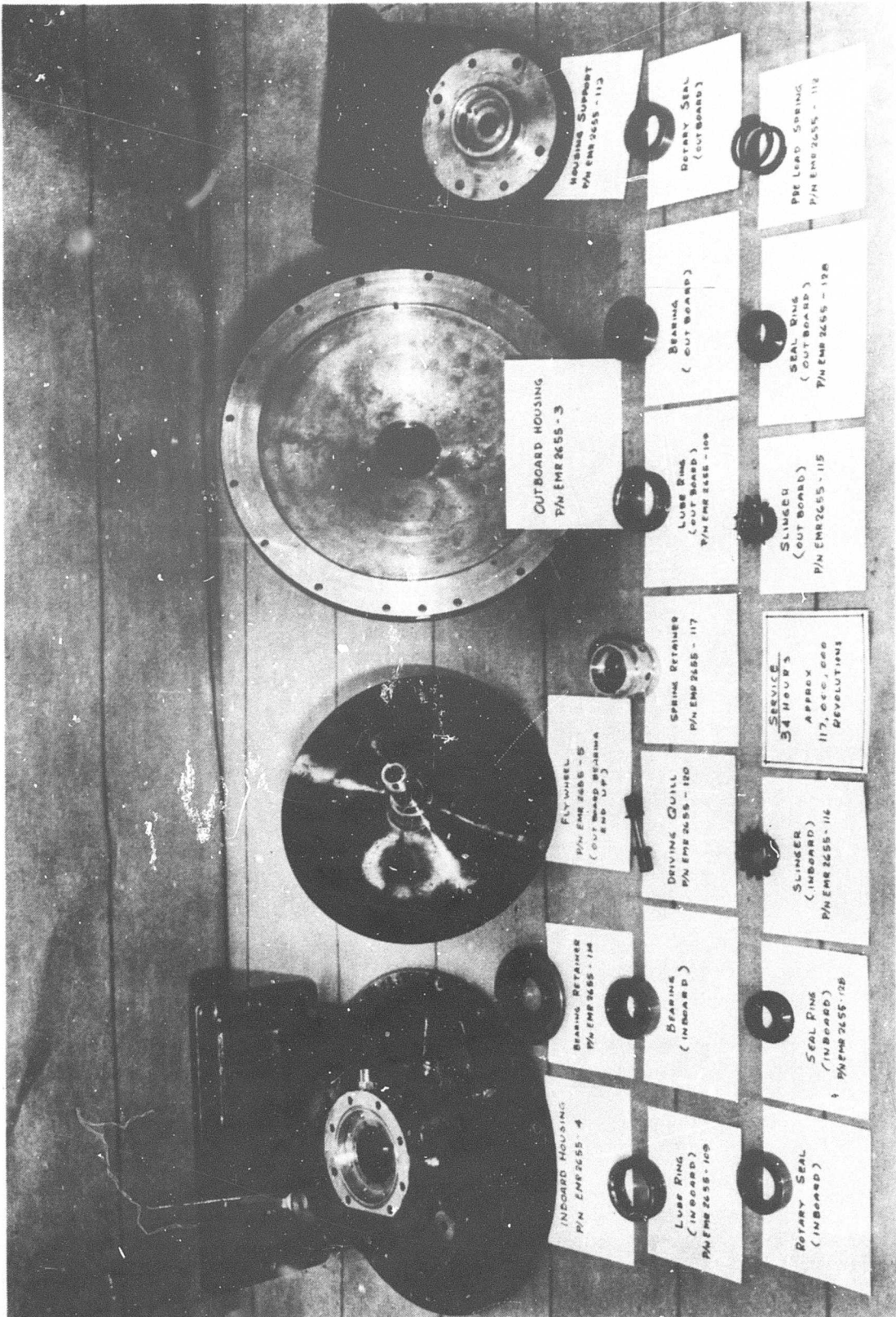

Figure 5. Flywheel Assembly

B. GEARBOX DESCRIPTION

The gearbox consists of a housing which contains three gears and mounts a gear-type service pump group. Figure 6 is the assembly drawing used for its manufacture and table II is an itemized parts list keyed to the callouts of figure 6.

The gearbox housing is fabricated from a heavy sectioned-aluminum sand casting. It is split down the middle and the two halves are doweled together so that all the gear shaft bores and bearing seats were machined in one setup to the extreme accuracy necessary for high-speed operation. The gears are hardened and lapped to attain the tooth profile accuracy required.

The larger gear has 190 teeth and is axially aligned with motor-pump mounting provisions which are on one of the housing halves. The motor-pump drives this gear through a spline at 8,000 rpm. This gear meshes with two other gears. One of these gears has 29 teeth, and therefore rotates at 52,414 rpm for introducing power into, and extracting power from, the flywheel through a splined quill shaft. The flywheel housing bolts rigidly to the gearbox and is machined to maintain accurate alignment between this gear and the flywheel. The gearbox is supported by this attachment which consists of a flange and two "outrigger" pads. This gives a rigid tripod-type support.

The other gear, which is in mesh with the motor-pump driven gear, has 175 teeth and rotates at 8,686 rpm. It is referred to as the PTO shaft gear and drives the mechanism for demonstrating mechanical power extraction in conjunction with the Intermittent Duty Cycle Simulator.

The service pump group is mounted in axial alignment with the motor-pump, on the opposite side (flywheel side) of the gearbox; therefore, it is also driven at 8,000 rpm. It consists of three gear pumps, one for generating lubrication pressure, one for lubricant scavenging from the flywheel bearings and gearbox, and the other for flywheel cavity evacuation. The pumps are located with respect to each other in the above order, with the vacuum pump being nearest to the gearbox.

Pump displacements are as follows:

| | |
|-------------------------|----------------------------|
| Lubricant pressure pump | .038 in. ³ /rev |
| Lubricant scavenge pump | .075 in. ³ /rev |
| Vacuum pump | .325 in. ³ /rev |

Lubricant from the pressure pump is squirted at the gear teeth in two places. This lubricates the gears and at the same time creates a mist which lubricates the bearings. A part of the lubricant flow is piped to the flywheel bearings as shown in the flywheel assembly drawing of figure 4.

C. MOTOR-PUMP DESCRIPTION

The basic motor-pump selected for this program was manufactured by the New York Airbrake Company, and has automatic pressure-sensing control for determining whether it should be motoring at full displacement or should be in the pumping mode. In the pumping mode, displacement is variable and is

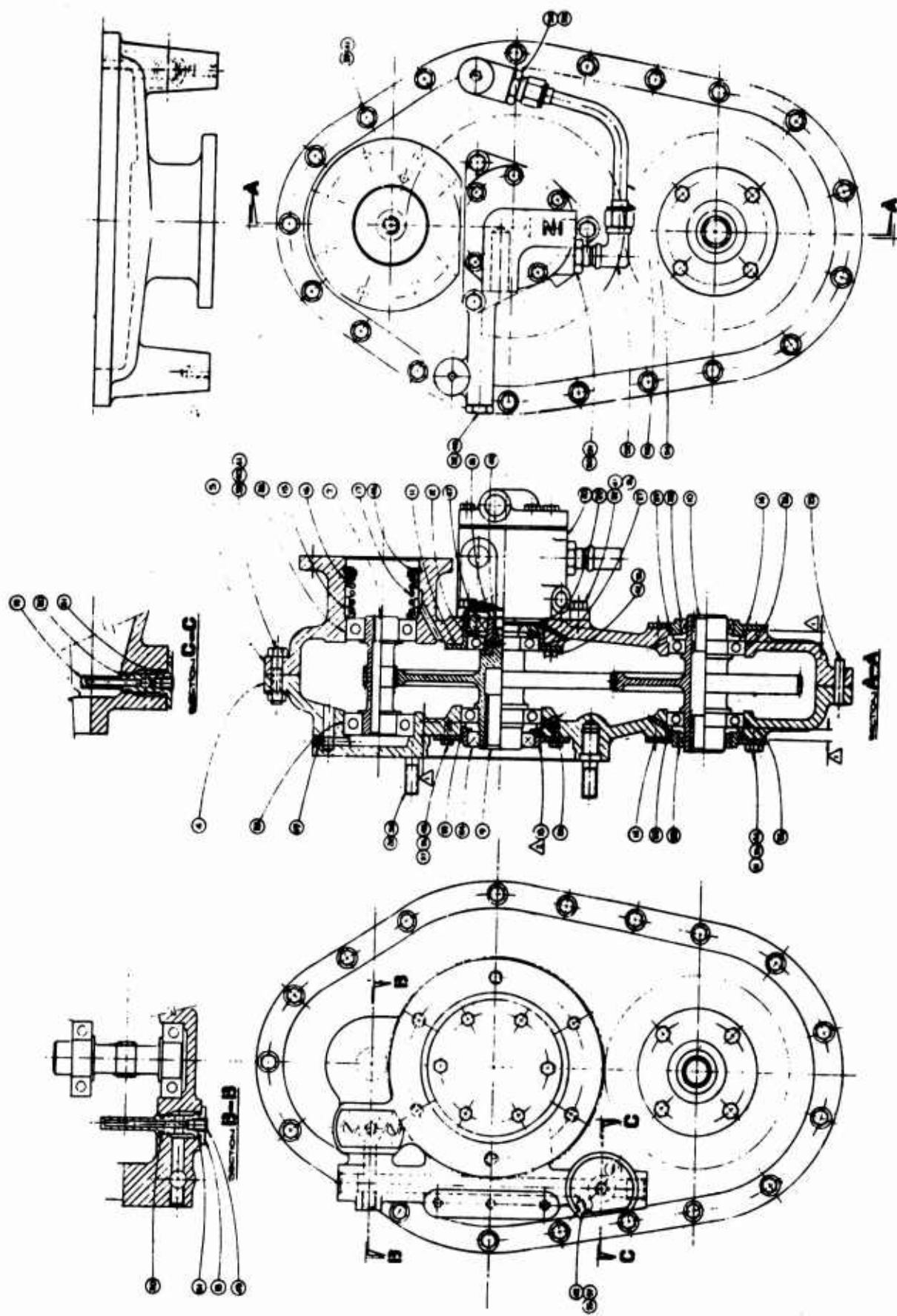

Figure 6. Gearbox

Table II
GEARBOX ITEMIZED PARTS LIST

| Item Number | Nomenclature |
|--------------------|-----------------|
| 4,5 | Housing - input |
| 7 | Pinion |
| 8 | Race |
| 9, 10 | Gear |
| 11 | Sleeve |
| 12 | Spacer |
| 13, 14 | Retainer |
| 15, 16 | Guide |
| 17 | Spring |
| 18, 19 | Oil jet |
| 20 | Pump |
| 25 | Taper pin |
| 26, 27, 28 | Bearing |
| 29, 30, 31, 32, 50 | O-ring |
| 33, 34 | Seal |
| 35 | Stud |
| 36 | Lock ring |
| 37, 38, 39, 43, 44 | Bolt |
| 40 | Nut |
| 41, 57 | Washer |
| 42 | Screw |
| 45 | Pin |
| 46 | Retaining ring |
| 47 | Clutch |
| 48, 49 | Plug |
| 51 | "B" nut |
| 52 | Elbow |
| 53 | Sleeve |
| 54 | Tube |
| 56 | Lock wire |

controlled by pressure. Three of these units were used in the program and were designated "automatic units." All three automatic units have flow regulators built into their control heads.

The Tilt Table Simulator used a modification of the above motor-pump design. The modification allowed manual control of the motoring and pumping mode by means of pressure supplied to an external port in the control head. An externally-attached flow regulator was used to limit motoring speed. This modified "manual" variety of motor-pump was actually a slightly revised version of an existing production unit which could be delivered on an early schedule. This was the principal reason that it was introduced into the program. Figure 7 is a cross-sectional view of this motor-pump.

A third variety of motor-pump was used in the Tilt Table Simulator testing. It was manufactured by Vickers, Inc, and was obtained (one unit) from the XB-70 program. It was introduced into the flywheel program, because several early failures of the prototype motor-pump, due to improper operating conditions, occurred and would otherwise have delayed flywheel testing.

A more detailed description for each of the units follows.

Figure 8 is an envelope drawing of the motor-pump₃ with "automatic" pressure sensing. It has a maximum displacement of .4 in./rev in both the motoring and pumping modes of operation. The rotating group is the same as that shown in figure 7. Each type contains nine pistons and has an operational speed of 8,000 rpm.

The pressure control of the "automatic" unit positions between full displacement and zero displacement in the pumping mode by regulating a variable pressure level to the displacement control actuator. This is dependent upon the existing aircraft system pressure. A low system pressure causes increased flow from the unit, thus extracting energy from the flywheel for high demands in the aircraft control system duty cycle. A higher aircraft system pressure causes the pumping mode to go to zero displacement. A further increase in the aircraft system pressure causes the mode control valve to port pressure into a chamber of the pressure control unit which moves an additional valve slide. Movement of this valve slide causes the mode control actuator to go to full displacement as a motor. Variations in the aircraft system pressure, above the minimum pressure which puts the unit in motoring mode, do not vary the displacement as a variable motor. The maximum speed is limited by a flow regulator in the high pressure port. The reason that the motor was made to operate as a fixed displacement unit, at all times while in the motoring mode, was to make it possible to limit the speed by means of a flow regulator. In some respects it would have been advantageous to use the motor as a variable displacement unit. For example, it would have smoothed the transition from pumping to motoring. However, to do so would have necessitated the use of some type of shaft speed sensing governor and would have complicated the development and procurement of the motor-pump unit considerably.

The above description also applies to the modified "manual" motor-pump except for the previously mentioned differences in the pressure control valving. Figures 9, 10, and 11 depict the variation. This modified unit requires

DISPLACEMENT CONTROL PISTON
(PUMPING MODE)

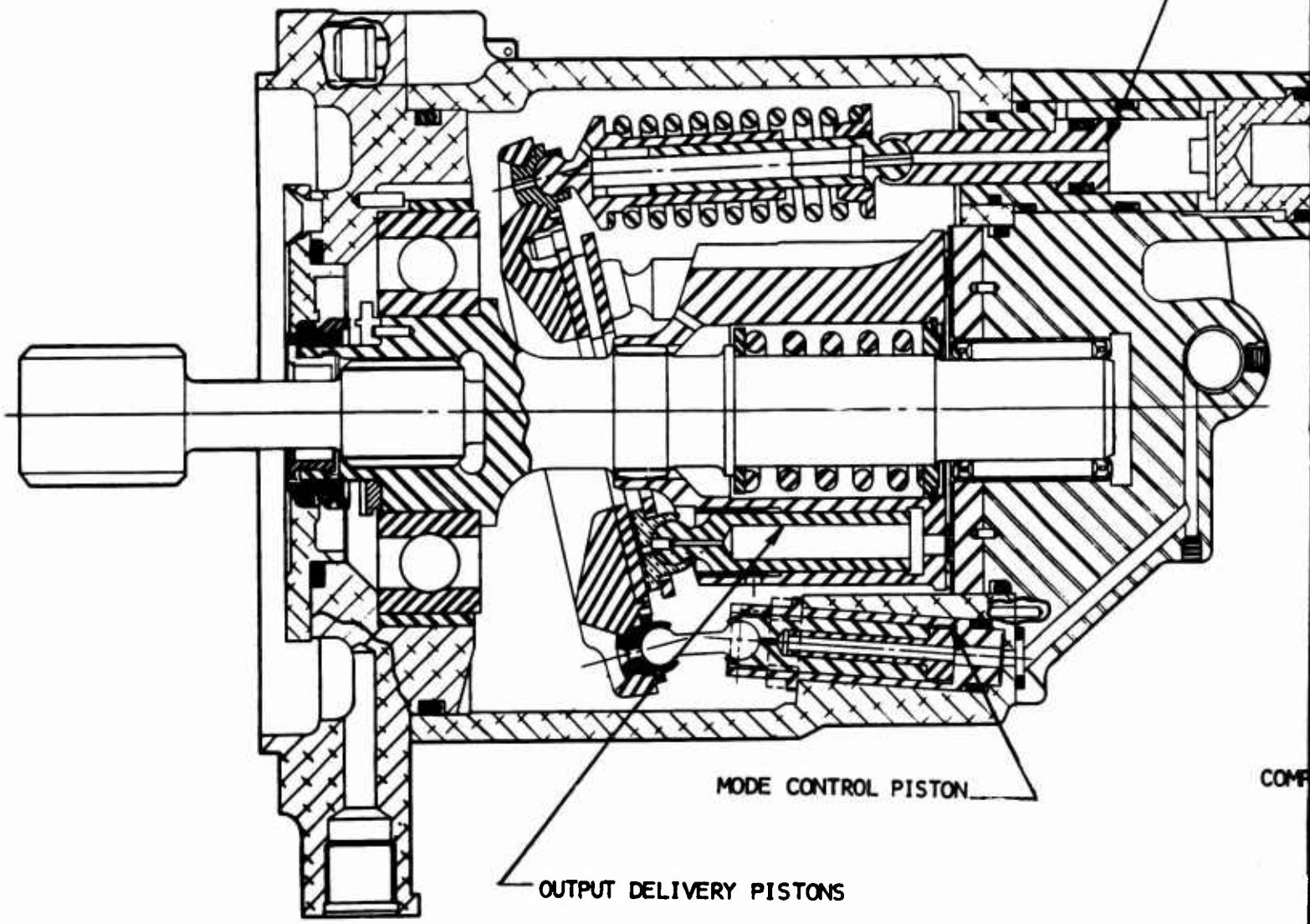

MODE CONTROL PISTON

OUTPUT DELIVERY PISTONS

COMP

A

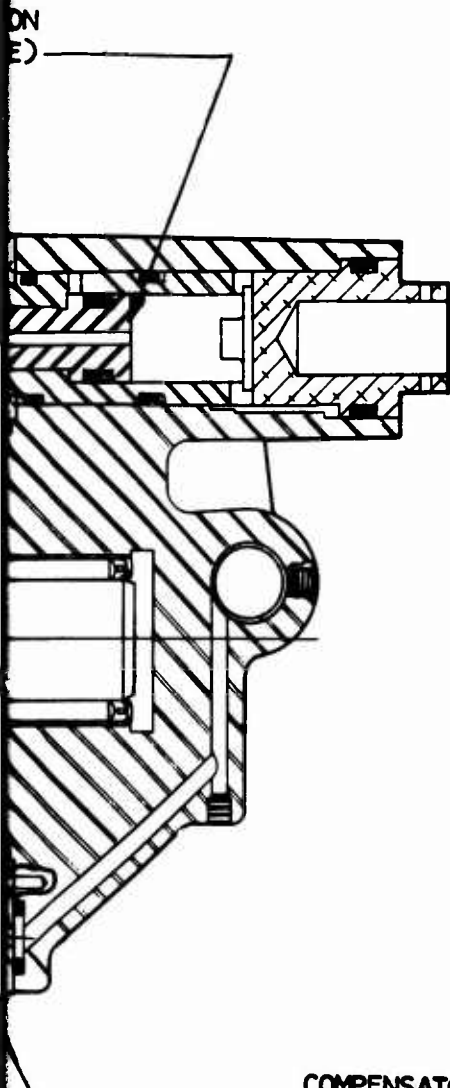

NEW YORK AIRBRAKE
MOD NO. 64WK02002

COMPENSATOR

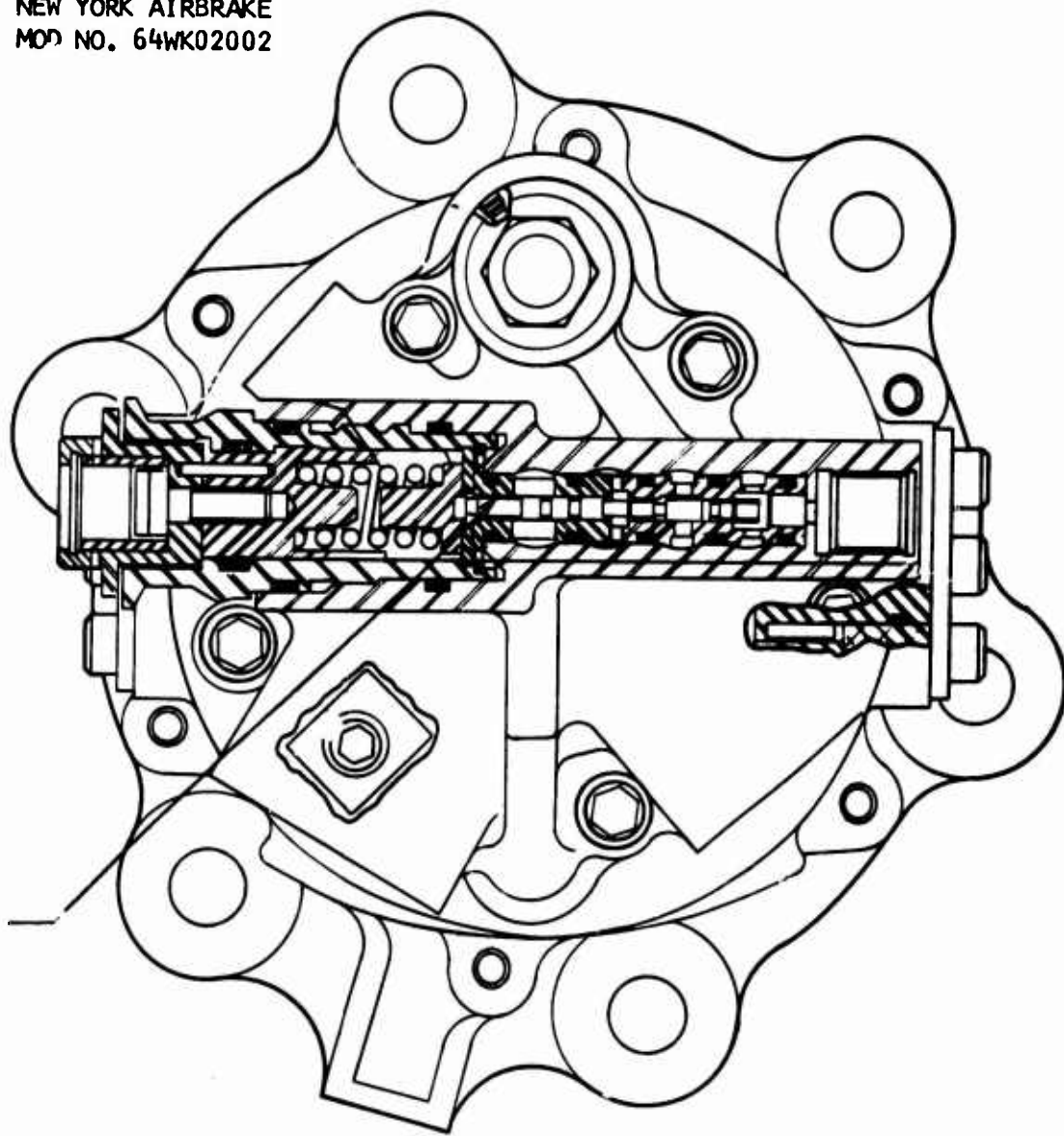
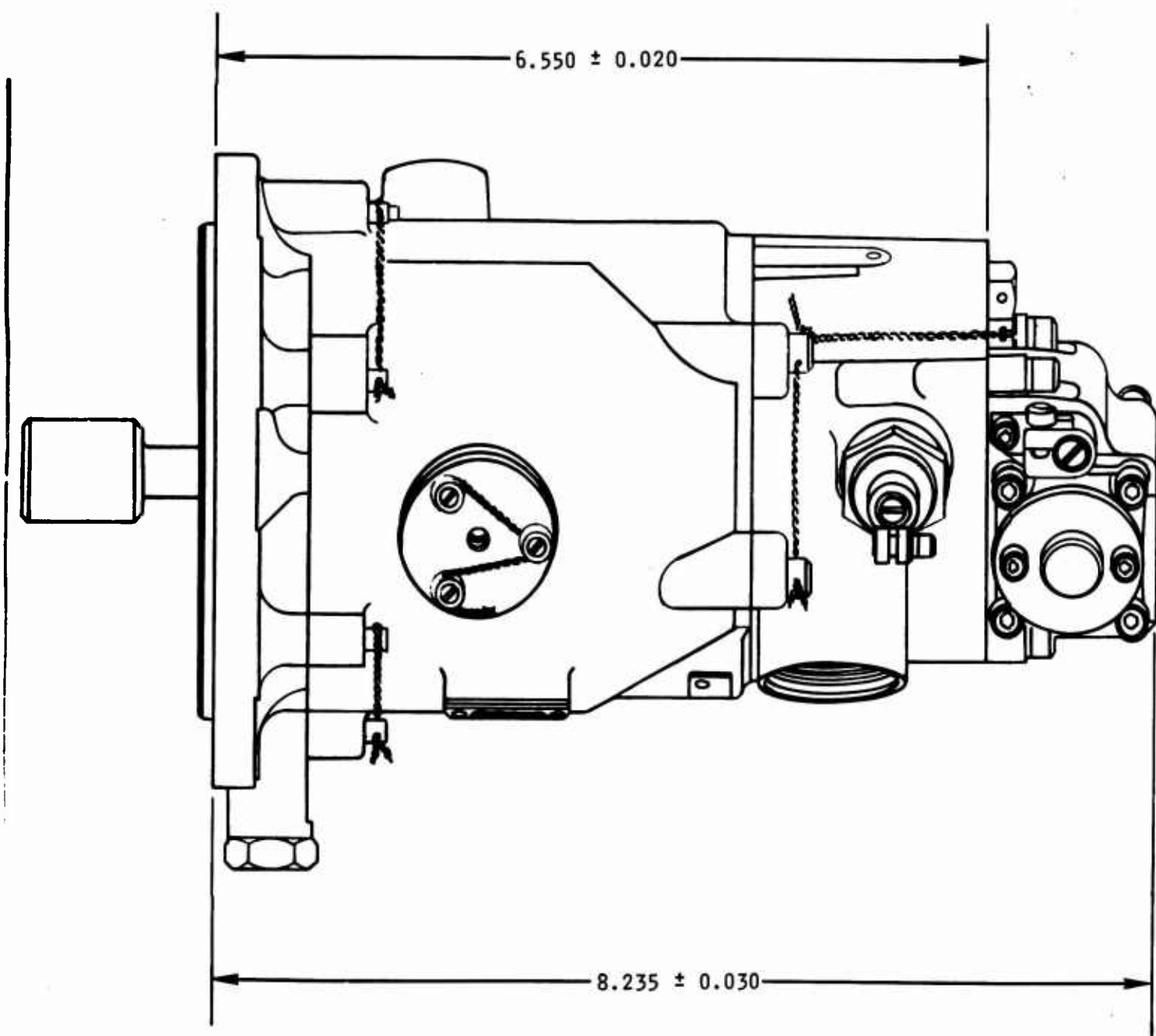

Figure 7. Manual Motor-Pump

B



A

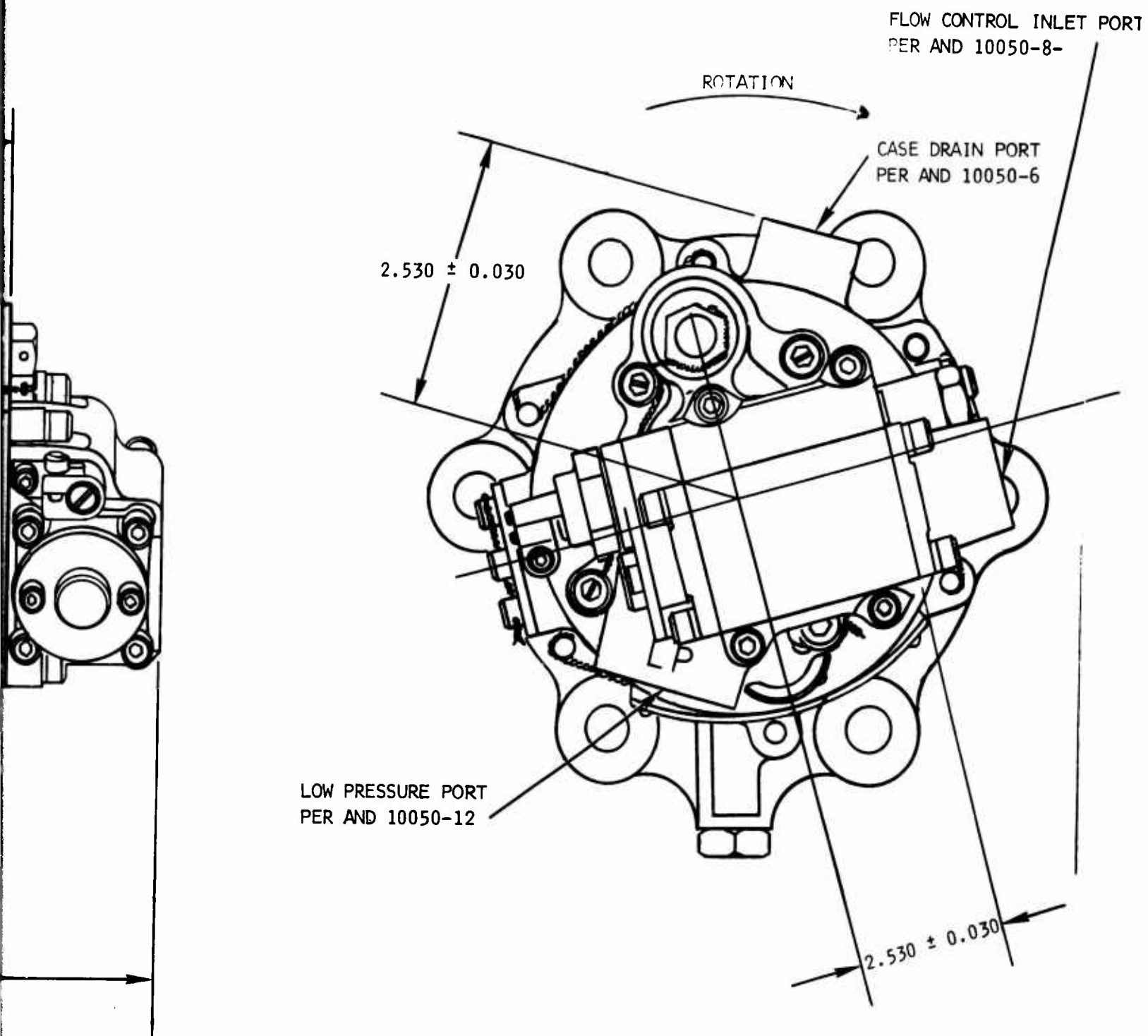

Figure 8. Automatic Motor Pump

B

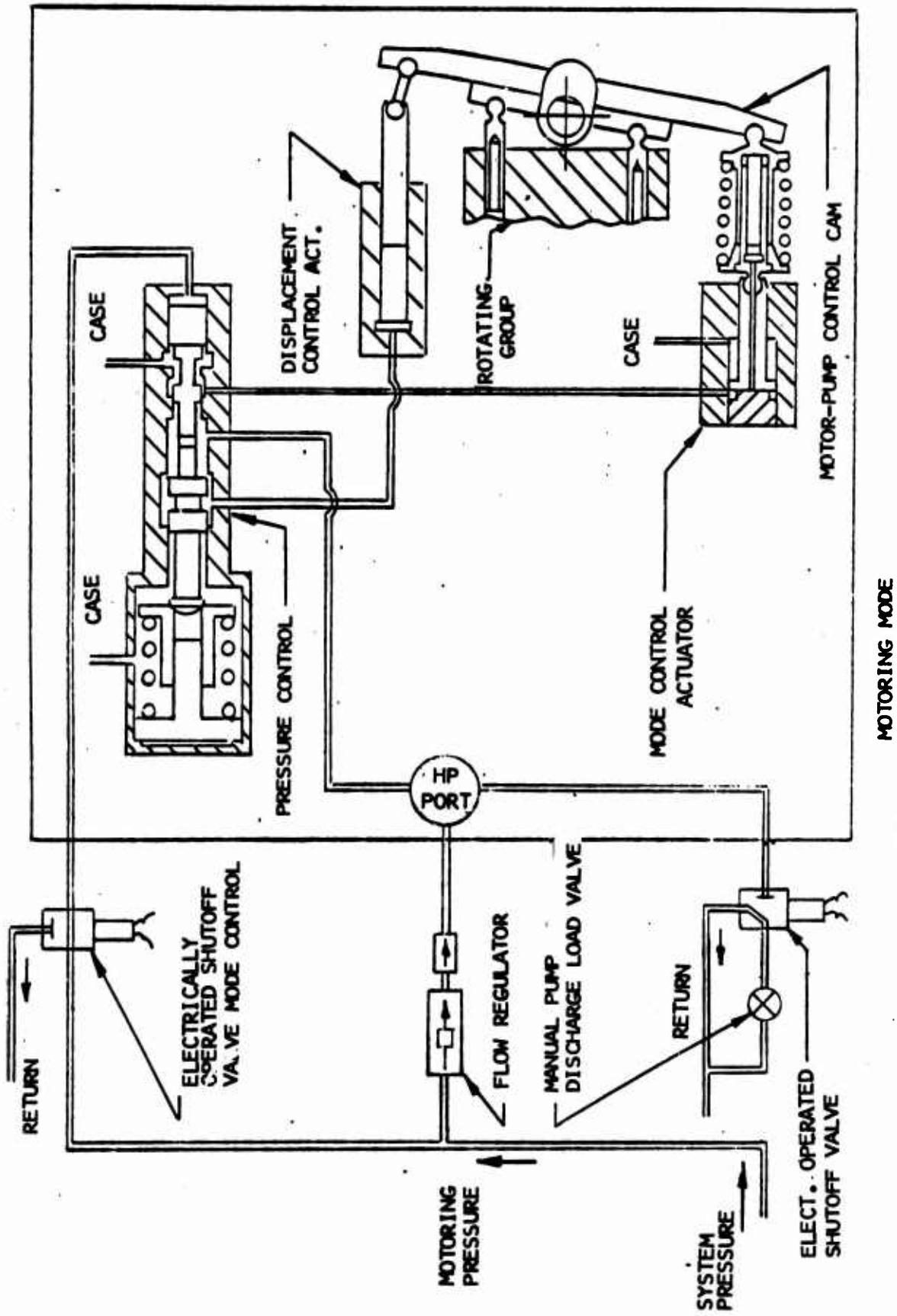

Figure 9. Prototype (Manual) Motor-Pump Configuration

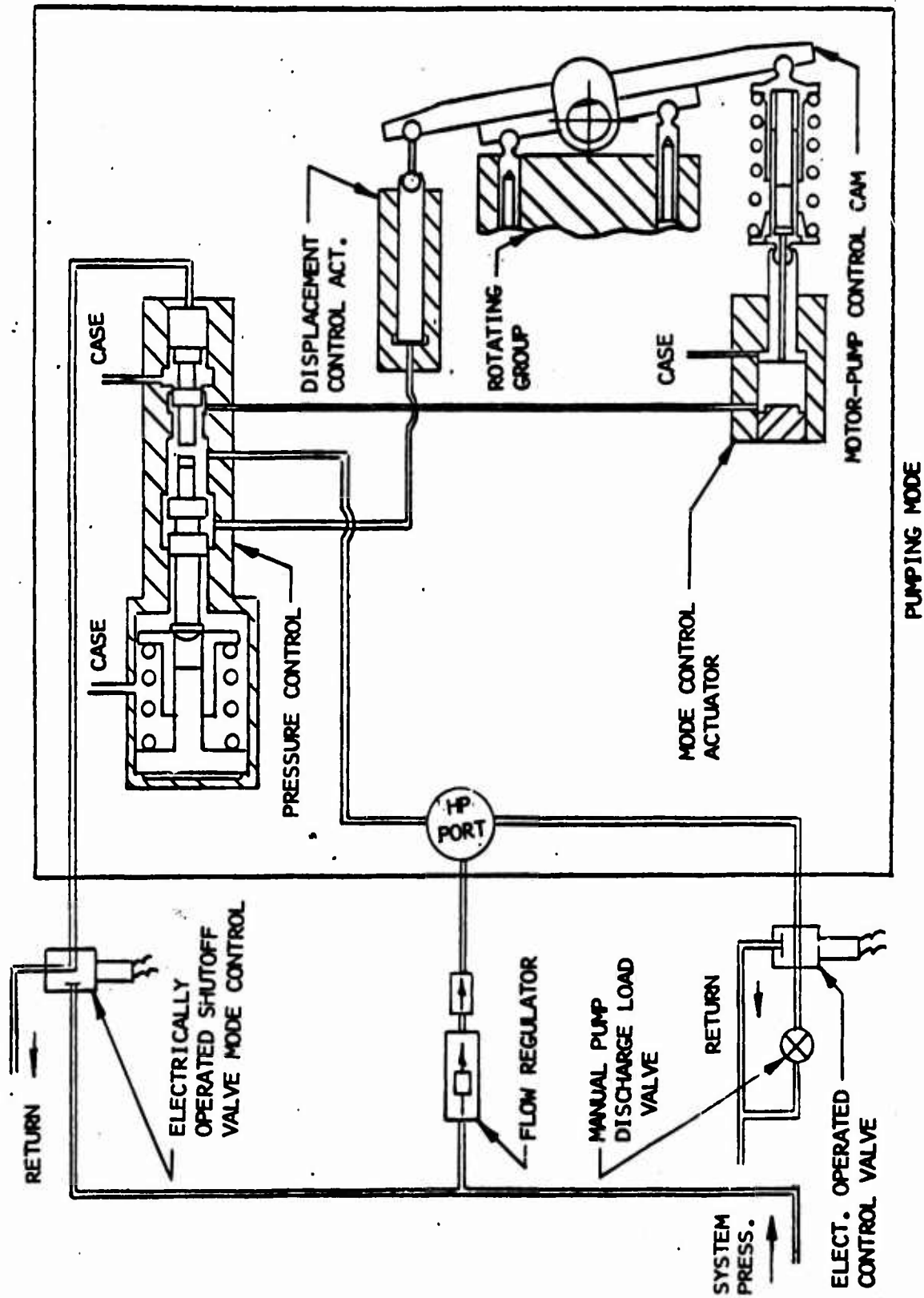

Figure 10. Prototype (Manual) Motor-Pump Control Configuration

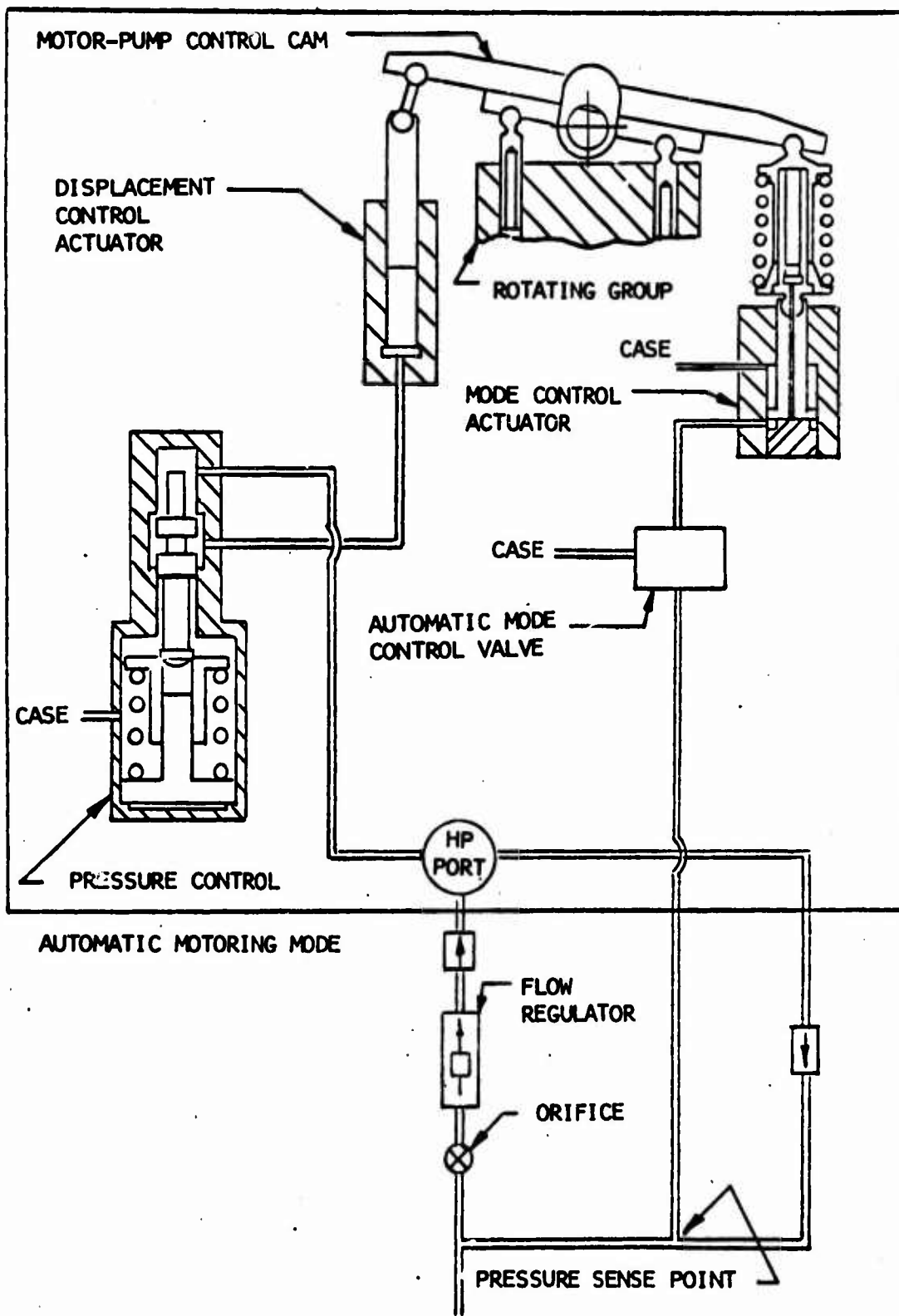

Figure 11. Automatic Motor-Pump Control Configuration

external valving in the test setup to apply dump pressure to the mode control actuator. The shift from motoring to pumping is manually controlled.

Figure 12 is a performance envelope for these New York Airbrake motor-pumps.

The third variety of motor-pump used in the program was from an XB-70 emergency generator application. The rotating group had been developed specifically for the XB-70 wing fold system and was modified for driving the emergency generator by adding a new control head for accurate speed control. The new unit had more displacement, but fortunately had exactly the desired speed built into its control head.

Figure 13 is a schematic diagram of the unit. Other pertinent data are:

| | |
|--------------------------|----------------------------|
| Displacement | .646 in. ³ /rev |
| Speed | 8,000 rpm |
| Rated operating pressure | 4,000 psi |

The application of this unit for the emergency generator required clockwise rotation as viewed from the mounting pad; however, for the energy storage substation application, counterclockwise rotation was required. By rotating the control head 180 degrees it was possible to meet the reversed rotation requirement. This change blocked the case return passage from the return port. To correct this, an external case return line to the reservoir was incorporated. In addition, the tapped mounting holes were reamed to accept the unthreaded shank of the gearbox mounting studs.

As seen in figure 13, this unit incorporates an anticavitation circuit which consists of a fluid recirculation loop. It is designed to protect the rotating group from cavitation when the inlet flow is suddenly reduced while the shaft continues to rotate due to the inertia load of the emergency generator rotor. Although this unit is not a motor-pump, the recirculation loop creates a partial pumping condition which was considered suitable for the application to part of the testing required on the Tilt Table Simulator. A further clarification of this unit's performance will be brought about in covering the actual endurance tests.

D. SUBSTATION WEIGHT

The substation shown in figures 1 and 2 stores 4,000,000 inch-pounds of energy at a weight of 91 pounds. If packaged for an actual air vehicle application, the same unit would weigh less than 60 pounds. The reason for the weight difference is the fact that this unit was standardized, as mentioned previously, so that it could be used in all three test simulators interchangeably. Because of this, certain compromises had to be made. As an example, the heavy feet seen on the flywheel in figure 2 were used to accurately transmit precessional loads to the tilt table bed. An actual air vehicle unit would probably be suspended on a light system of tension struts. Also, the PTO gear portion of the gearbox (seen bulging down in the lower portion of figure 1) is used for only one out of the four tests being conducted (i.e., the intermittent duty cycle mechanical system demonstration). In other words, the gearbox weighs at least one-third more than necessary

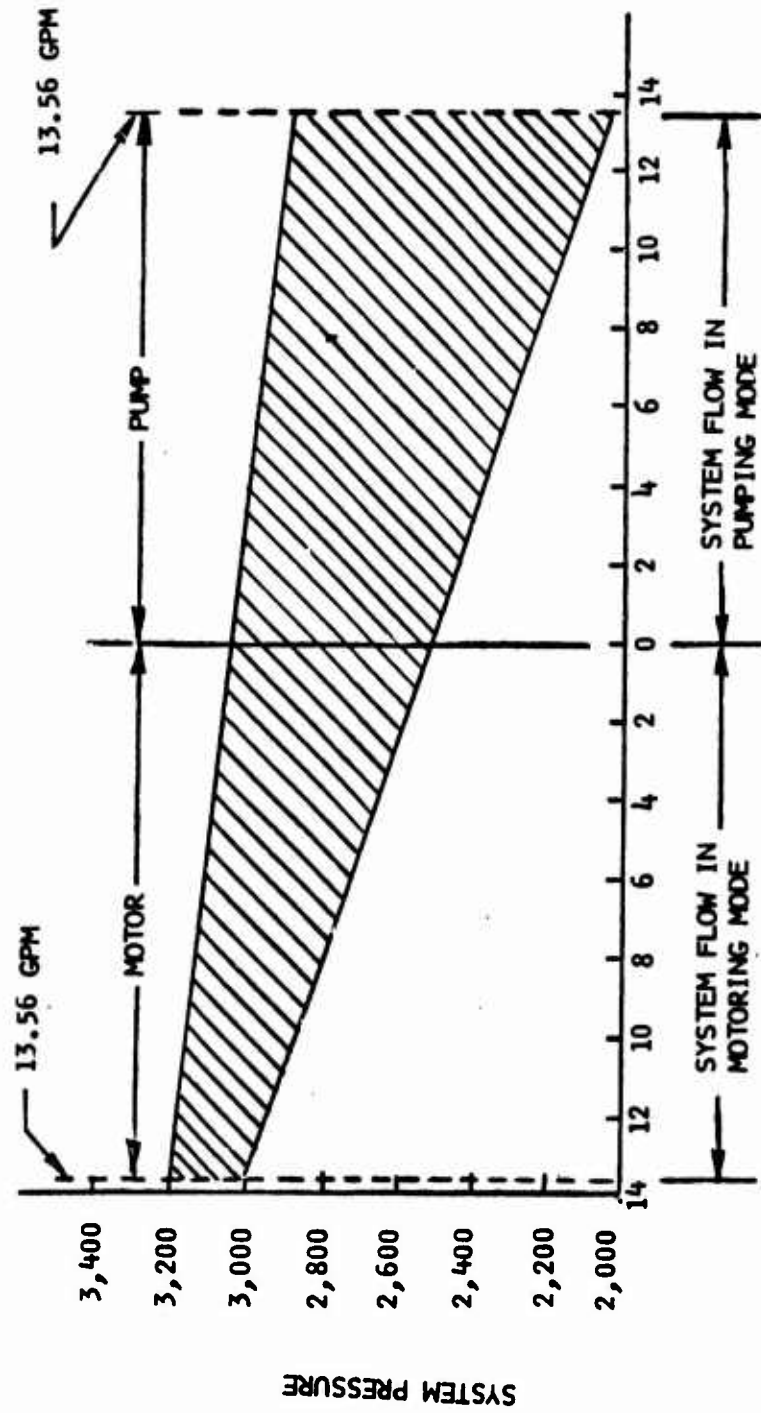

NOTE: 8,100 RPM IS MAXIMUM UNDER ALL LOADING CONDITIONS.

Figure 12. Motor-Pump Performance

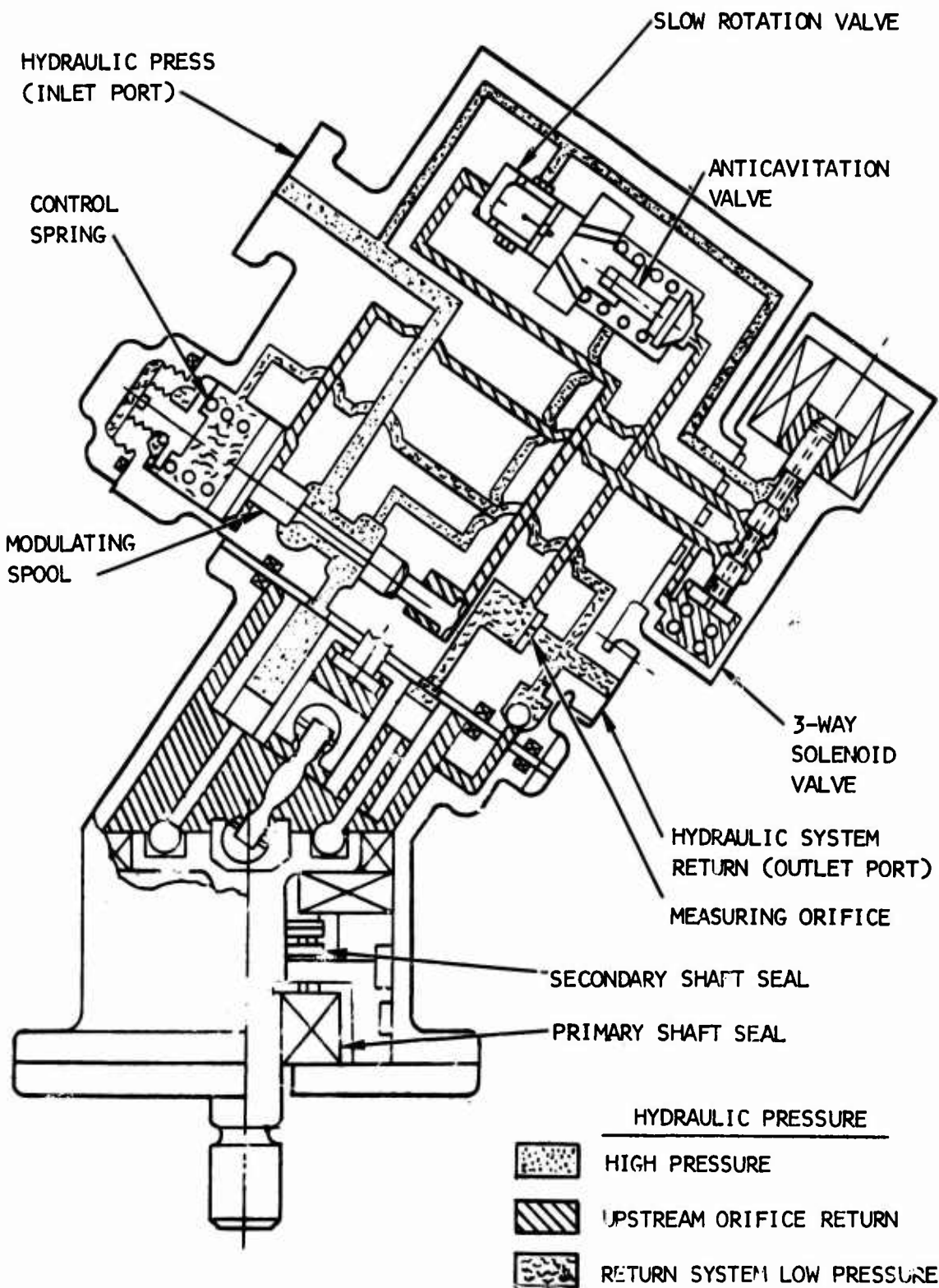

Figure 13. Hydraulic Motor Schematic Diagram

for an actual air vehicle application. It is interesting to note that assuming 60 pounds is a realistic figure for actual air vehicle hardware, this unit's weight is approximately midway between the weights assigned to it for the elevon and main landing gear applications in the Phase I study (54 and 77 pounds, respectively). However, the elevon study of Phase I assumed a 25 percent speed reduction whereas it will be shown later that the actual hardware only experienced an 8 percent speed reduction. This means that the actual air vehicle unit could be 7 pounds lighter (53 pounds total) and still meet the performance of the study unit. Based on these facts it is quite apparent that actual air vehicle hardware will be lighter in weight than the weight values used for the study.

Section III

TILT TABLE SIMULATOR

A. SIMULATOR

The Tilt Table Simulator is a table which is designed to tilt in a controllable manner, on which a flywheel energy storage substation is mounted. Figure 14 shows the simulator in a partially tilted attitude. Figure 15 is a schematic diagram of the test setup. It was used for the investigation and demonstration of flywheel precessional effects on bearings, and to assess the potential gyroscopic effects as related to aircraft stability. An additional principal benefit derived from operation of the tilt table was the experience with the operation of a system of bearings and its associated lubrication system at high speeds.

The tilt table itself is of channel iron construction. The movable platform, on which the flywheel energy storage substation is mounted, is a 16-inch square metal plate 1/2 inch thick. It is pivoted on flange-type ball bearings wherein a 1-inch diameter hole is provided at the bearing centerline axis through which hydraulic lines are routed.

The substation used consists of a motor-pump unit with modified manual control, a gearbox, and a flywheel. The modification of the control permitted the substation to be electrically operated to assume a full motoring mode and a full pumping mode according to the position of the mode and dump valves which are external to the tilt table, but are part of the test setup adjacent to the laboratory hydraulic supply.

A manual pump discharge load valve (see figure 15) downstream of the electrically-operated shutoff valve allowed pressure drop to be regulated at the flow desired to exercise the system at its design capacity. A flow regulator, supplied as part of the motor-pump, is installed in the high-pressure line coming from the laboratory supply to control maximum flywheel speed.

B. PRECESSIONAL LOAD TEST SPECTRUM

A basic objective of the Tilt Table Simulator endurance tests was to show the effects of 3,000 hours of XB-70 airplane flight time on the flywheel bearings in 100 hours of total test time. The analysis of the problem and the spectrum which was established also included other varieties of air vehicles. It is felt that the selection quite well covers the range of performance for manned high-performance air vehicles. Their inclusion and the manner in which they were included provide a scale of values against which the energy storage substation was tested.

The calculated value for bearing life shown in table III and entitled "Percent of Bearing Life Consumed in 3,000 Flight Hours" can be seen to be very low. This could lead to the conclusion that bearings do not represent a problem in flywheel design and would be a correct assumption if the mode of failure were always ball race fatigue.

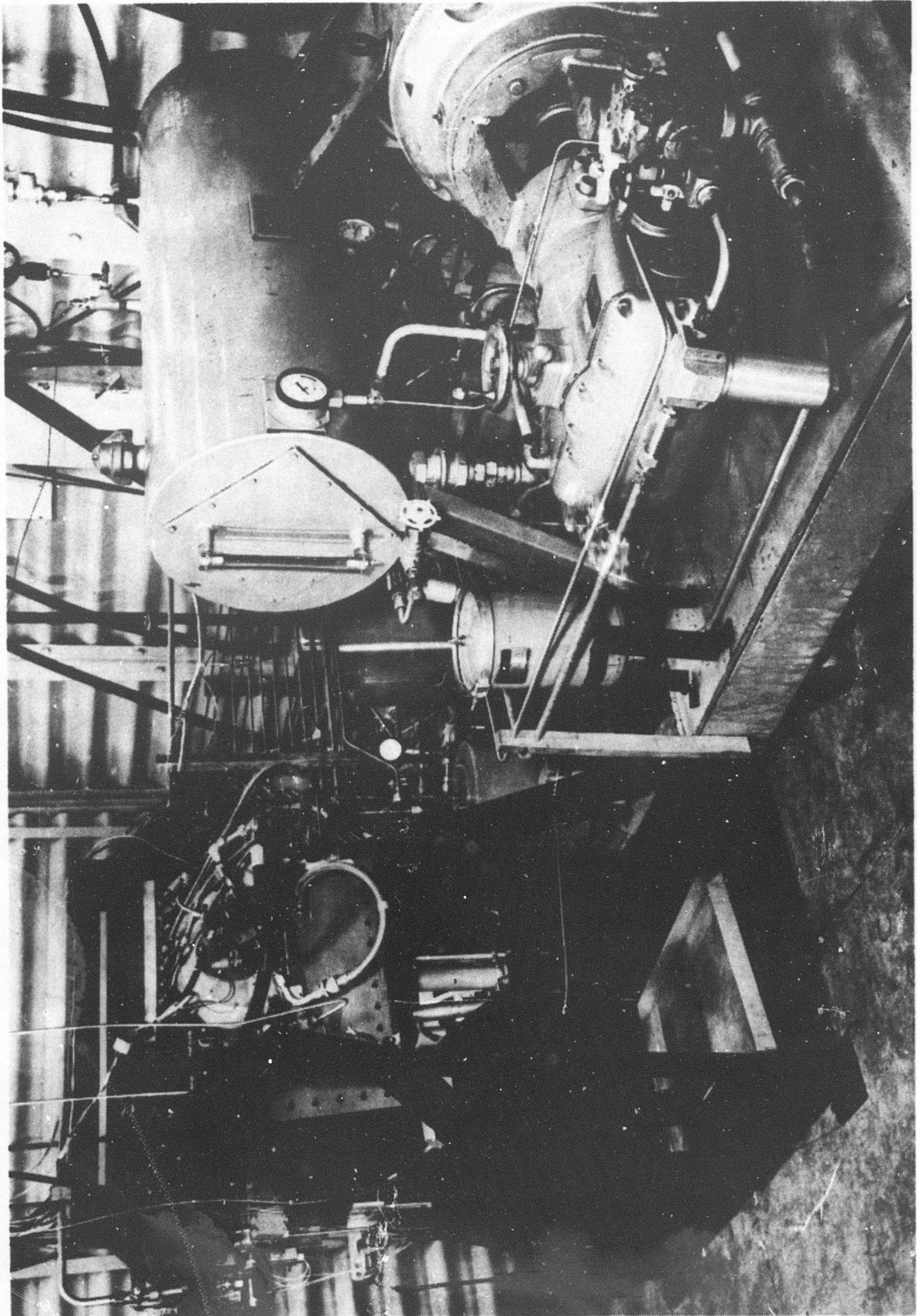
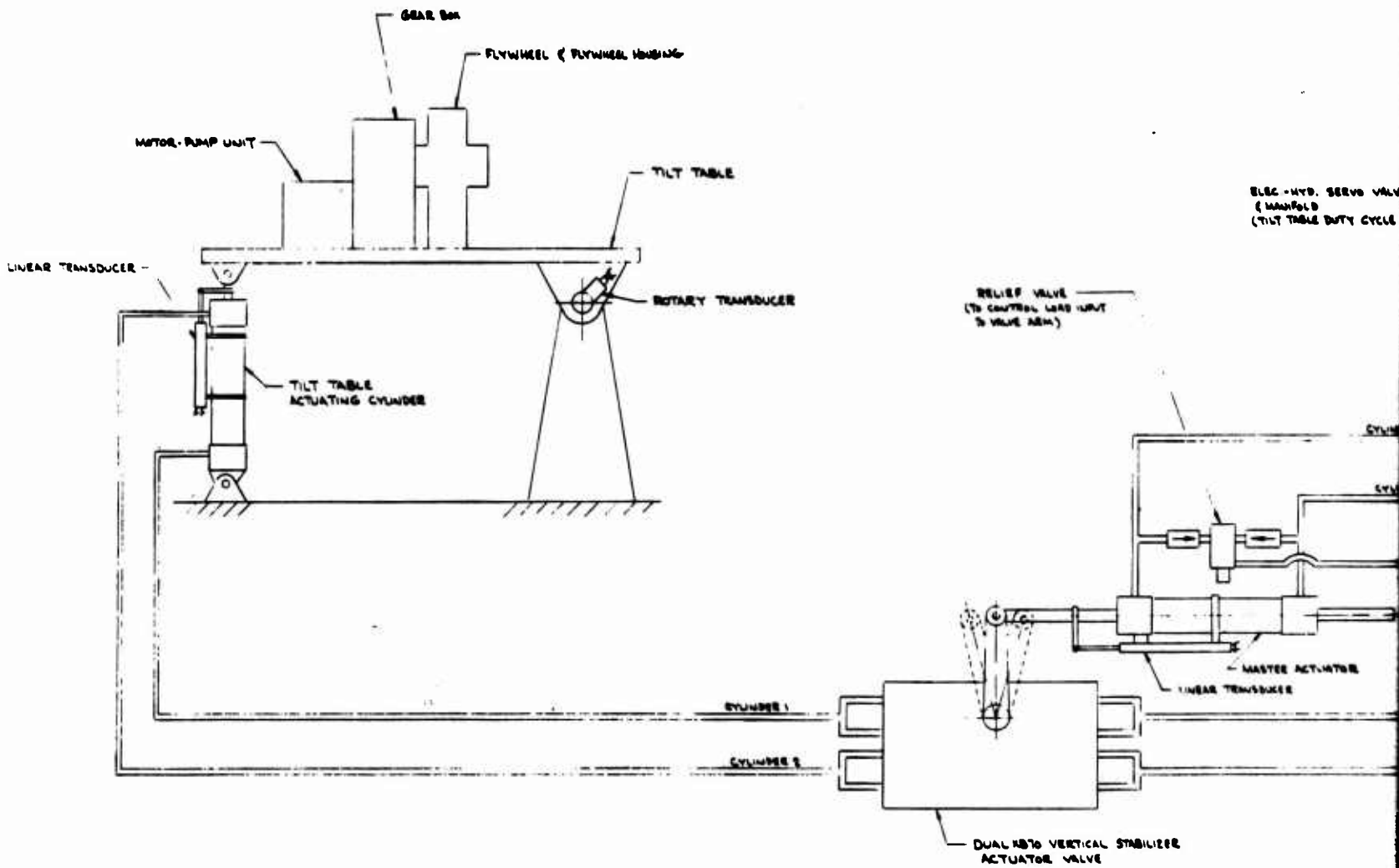
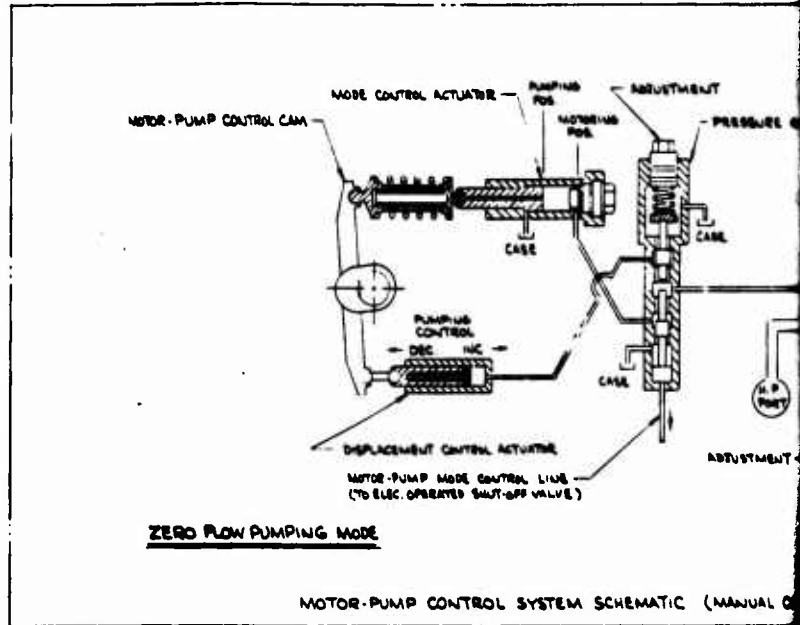
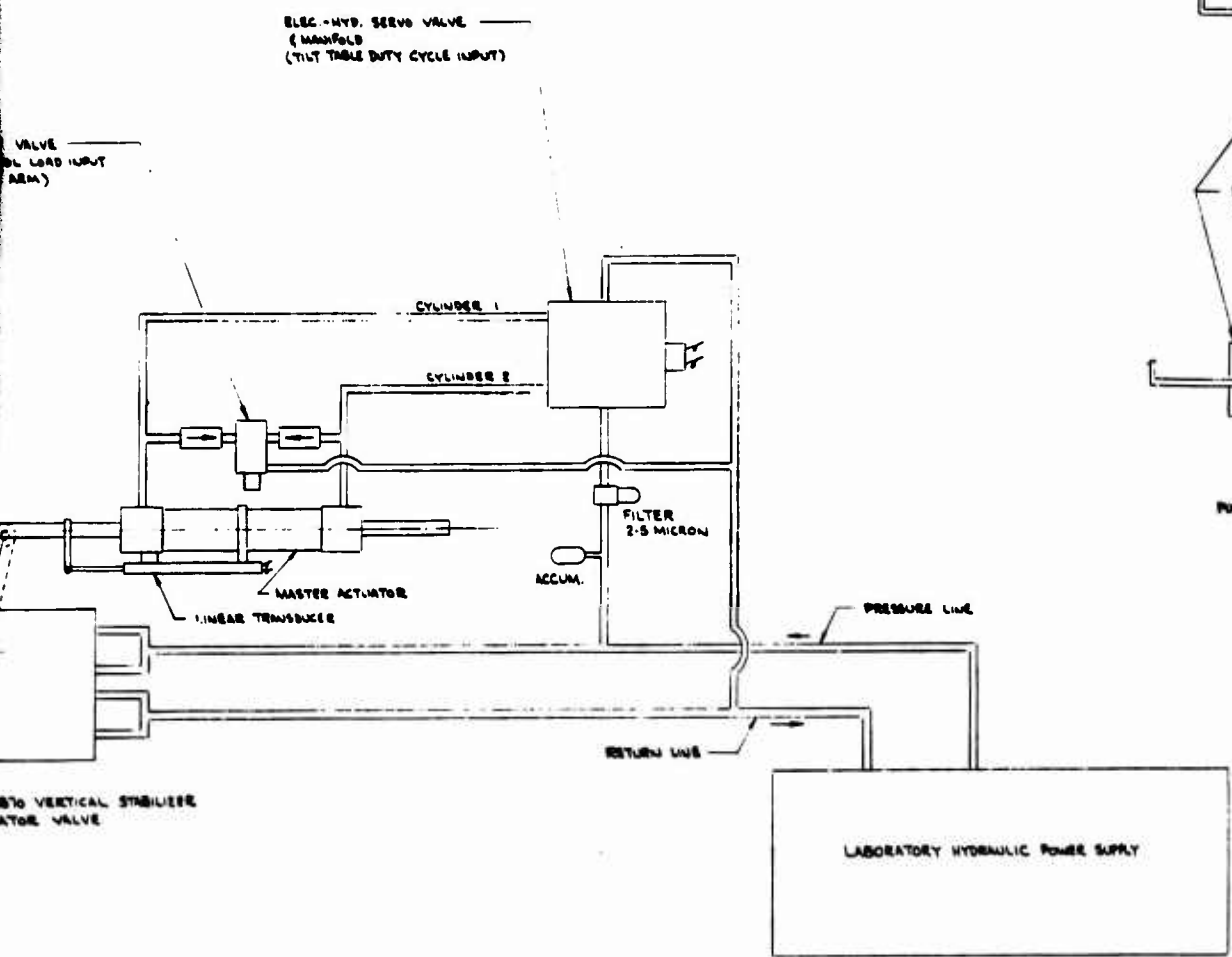
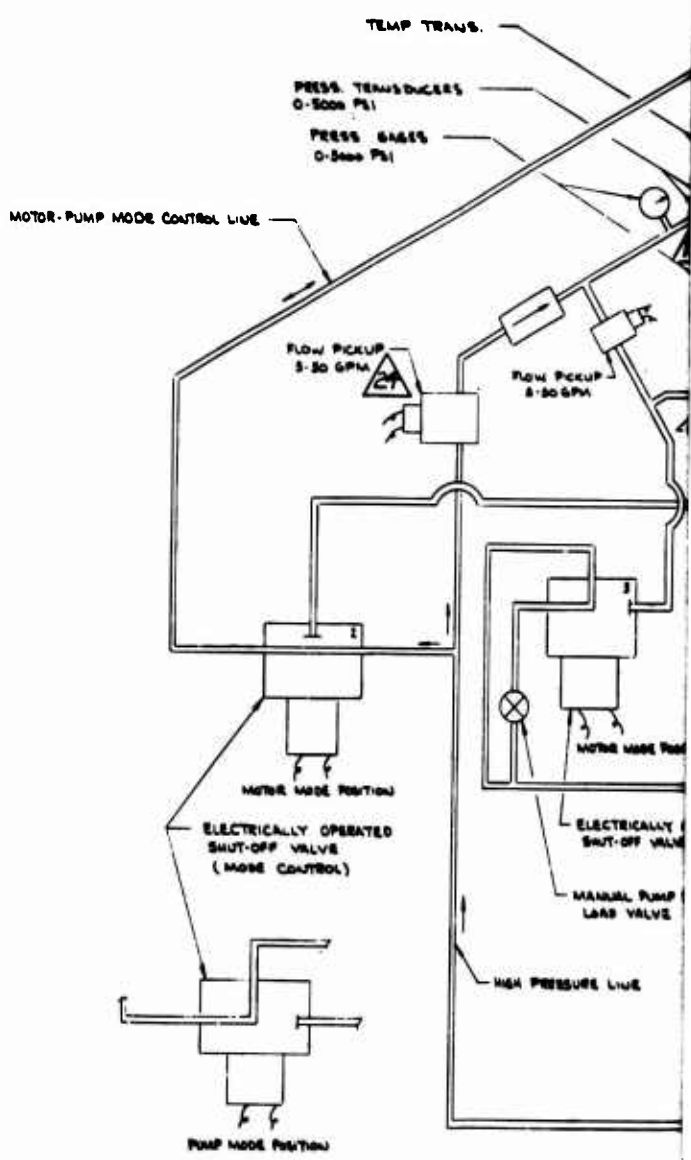
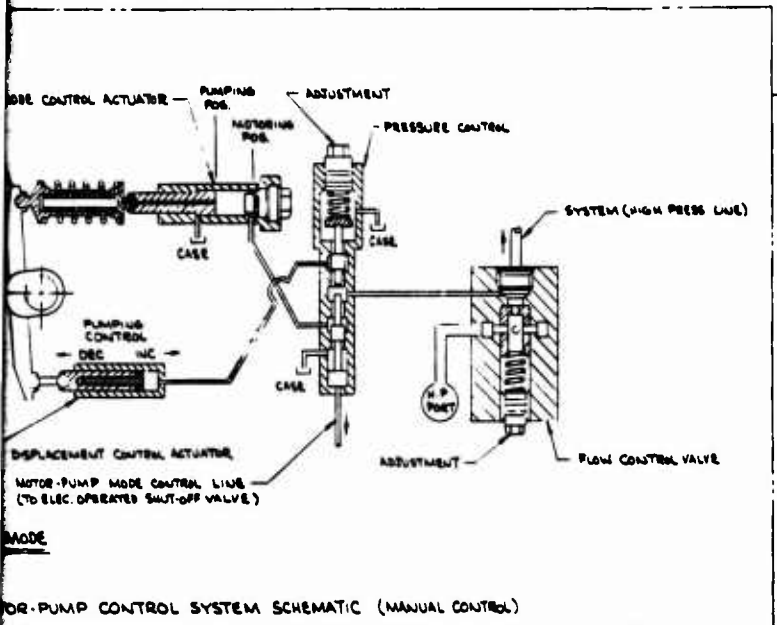

Figure 14. Tilt Table Simulator



A



B

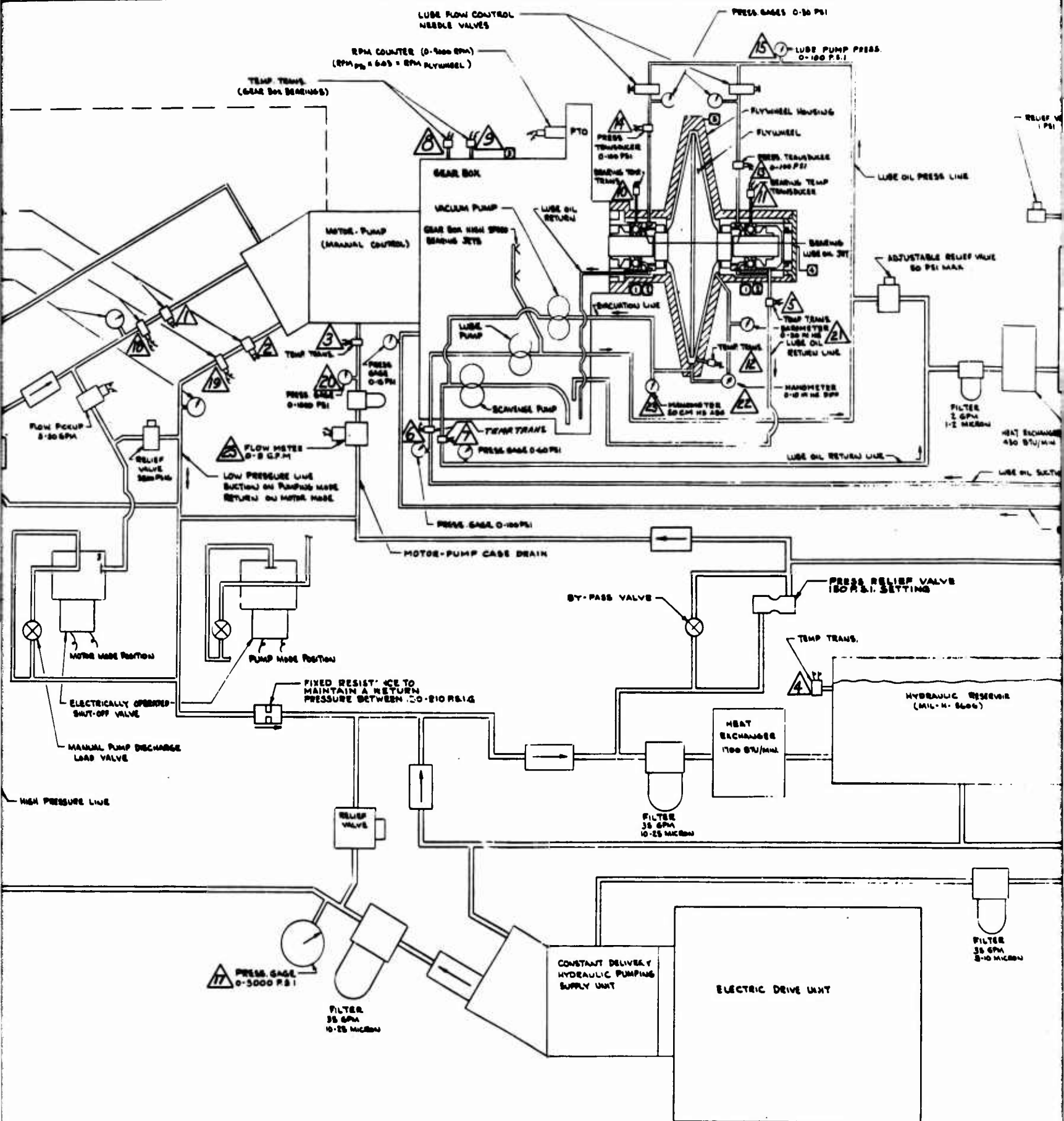

CODE  INDICATES TEST POINT ON DATA SHEET

c

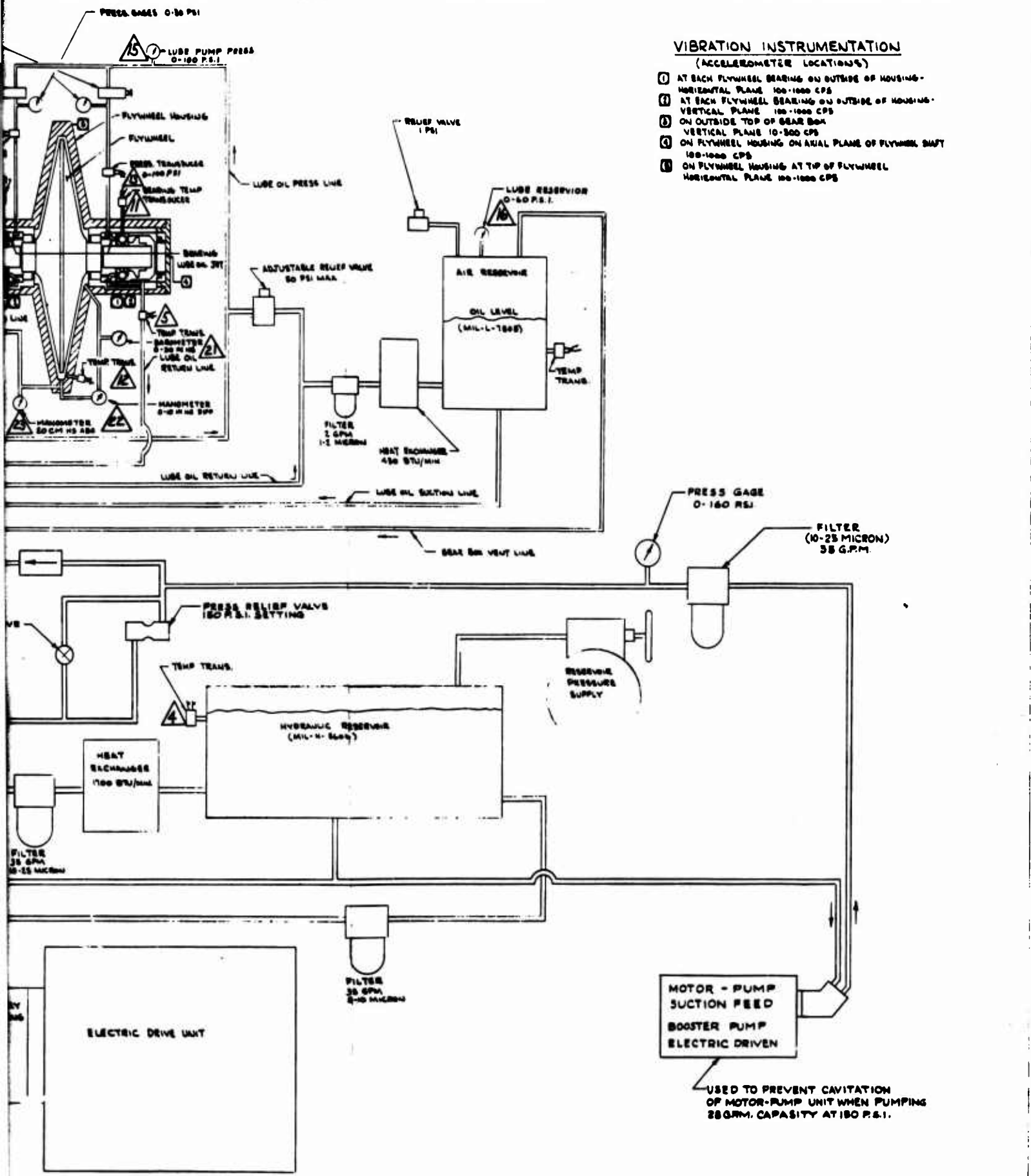

VIBRATION INSTRUMENTATION

(ACCELEROMETER LOCATIONS)

- ① AT EACH FLYWHEEL BEARING ON OUTSIDE OF HOUSING - HORIZONTAL PLANE 100-1000 CPS
- ② AT EACH FLYWHEEL BEARING ON OUTSIDE OF HOUSING - VERTICAL PLANE 100-1000 CPS
- ③ ON OUTSIDE TOP OF BEAR BOX - VERTICAL PLANE 10-300 CPS
- ④ ON FLYWHEEL HOUSING ON AXIAL PLANE OF FLYWHEEL SHAFT 100-1000 CPS
- ⑤ ON FLYWHEEL HOUSING AT TOP OF FLYWHEEL - HORIZONTAL PLANE 100-1000 CPS

CODE INDICATES TEST POINT ON DATA SHEET

D

Figure 15. Schematic - Energy Storage Substation Tilt Table

Table III

TILT TABLE TEST TIME AND PRECESSIONAL RATE REQUIREMENTS

| Aircraft Group | XB-70 | | | Noted* | | | Fighter-Reconnaissance | | |
|--|---------------|---------------|---------------|---------------|---------------|---------------|------------------------|------|--|
| | Pitch | Roll | Pitch | Roll | Pitch | Roll | Pitch | Roll | |
| Maximum precessional rate in maneuver | 10 deg/sec | 30 deg/sec | 10 deg/sec | 100 deg/sec | 20 deg/sec | 180 deg/sec | | | |
| Precessional rate for tilt table to include a "G" factor | 11.7 deg/sec | 30.9 deg/sec | 11.7 deg/sec | 101.7 deg/sec | 23.5 deg/sec | 182 deg/sec | | | |
| Precessional load resultant from tilt table rate | 54 lb | 143 lb | 54 lb | 470 lb | 108 lb | 838 lb | | | |
| Percent of bearing life consumed in 3,000 flight hours | .0265 percent | .0323 percent | .0433 percent | .617 percent | .0577 percent | 3.861 percent | | | |
| Test time required** | 38 hr | 2.5 hr | 62 hr | 1.3 hr | 10.3 hr | 1.48 hr | | | |

* Medium size low-level strategic aircraft

** Test time is established on basis that entire test is performed at the precessional rate of line 4.

BLANK PAGE

Ball race fatigue is the limiting mode of failure for a properly designed, installed, and lubricated bearing which is operated within the load and speed limits for which it was designed. This limiting (longest possible) life can be consistently attained with low speed bearings. However, as bearing speed (DN value) goes up failures, due to other failure modes which are less predictable and controllable, tend to increase in frequency. These other failure modes include, but are not limited to, wear-out failure (usually due to contaminated lubricant), overheat failure (frequently due to improper lubrication system design), and ball separator failure (usually due to improper bearing geometry for the loads and speeds encountered). When these types of failure occur they can, and frequently do, reduce bearing life by several orders of magnitude compared to the bearing life (L) predicted from the above formula.

For the purpose of this program, the problem was attacked by first tabulating pitch, roll, and yaw maneuvers for groups of airplanes which are categorized by their general similarity of flight characteristics (tables IV and V). It will be noted that a table for yaw maneuvers is not included. This is because yaw rates were found to be so small that they could safely be neglected. The airplane groupings are long-range, high-altitude aircraft (XB-70); medium-size, low-level strategic aircraft; and fighter-reconnaissance aircraft. The acceleration and angular velocity characteristics with respect to time for each maneuver was then approximated by a trigonometric function, wherein the general characteristic of a sine wave is predominant. An integration of the time at precession rate for each kind of maneuver of a general airplane class was performed and this allowed the construction of the "time exceedance" curves shown in figures 16 through 21.

The time exceedance curves were stepped off in appropriate increments to establish the total percentage of available bearing life that its particular maneuver would use up in the particular aircraft group for which it represents a 3,000-hour flight life. This percentage, together with test time requirements, is listed in table III. The bearing life from which the percentage is proportioned was established by the conventionally accepted equation:

$$L = (C/P)^3$$

wherein:

L = life of bearing

C = a constant established from a known life of the bearing at a known rated load and its design speed

P = load applied to bearing which will result in a life equal to L

It should be noted that the test time requirements could have been listed for several magnitudes of load (i.e., tilt table precessional rate). The one listed represents the maximum precession load plus a G-load increment. In any event, it can readily be seen by inspection that as the load application due to tilt table precession becomes higher, the test time requirement becomes shorter.

Table IV

PITCH RATE DUTY CYCLES



| B-70 Missions | | | | Manned Strategic Aircraft Missions | | | | F-R Missions | | | |
|---------------|---------|---------------|-------------|------------------------------------|---------|---------------|-------------|--------------|---------|---------------|-------------|
| A (deg/sec) | T (sec) | Reps Per Hour | theta (deg) | A (deg/sec) | T (sec) | Reps Per Hour | theta (deg) | A (deg/sec) | T (sec) | Reps Per Hour | theta (deg) |
| 10 | 4 | 1 | 12.7 | 10 | 4 | 1 | 12.7 | 20 | 4 | 1 | 25.4 |
| 8 | 1 | 150 | 2.6 | 8 | 1 | 250 | 2.6 | 15 | 4 | 1 | 19.0 |
| 5 | 1 | 100 | 1.6 | 5 | 1 | 200 | 1.6 | 10 | 4 | 1 | 12.7 |
| 5 | 4 | 25 | 6.4 | 5 | 4 | 25 | 6.4 | 8 | 1 | 250 | 2.6 |
| 1 | 4 | 25 | 1.3 | 1 | 4 | 25 | 1.3 | 5 | 1 | 200 | 1.6 |
| 1 | 8 | 12 | 2.6 | 1 | 8 | 12 | 2.6 | 5 | 4 | 25 | 6.4 |
| 0.5 | 8 | 12 | 1.3 | 0.5 | 8 | 12 | 1.3 | 1 | 4 | 25 | 1.3 |
| | | | | | | | | 1 | 8 | 12 | 7.6 |
| | | | | | | | | 0.5 | 8 | 12 | 1.5 |

Table V
ROLL RATE DUTY CYCLES



| B-70 Missions | | | | Manned Strategic Aircraft Missions | | | | F-R Missions | | | |
|---------------|---------|-------------|----------------|------------------------------------|---------|-------------|----------------|--------------|---------|-------------|----------------|
| A (deg/sec) | T (sec) | theta (deg) | Reprs Per Hour | A (deg/sec) | T (sec) | theta (deg) | Reprs Per Hour | A (deg/sec) | T (sec) | theta (deg) | Reprs Per Hour |
| 30 | 2 | 30 | 0.4 | 100 | 1 | 50 | 0.6 | 180 | 1 | 90 | 1.0 |
| 15 | 4 | 30 | 2.0 | 50 | 2 | 50 | 2.0 | 100 | 1 | 50 | 1.0 |
| 10 | 4 | 20 | 2.0 | 25 | 4 | 50 | 2.0 | 50 | 2 | 50 | 2.0 |
| 5 | 4 | 10 | 2.0 | 10 | 4 | 20 | 2.0 | 25 | 4 | 50 | 2.0 |
| 2 | 10 | 10 | 2.0 | 5 | 4 | 10 | 2.0 | 10 | 4 | 20 | 2.0 |
| 1 | 10 | 5 | 5.0 | 2 | 10 | 10 | 2.0 | 5 | 4 | 10 | 2.0 |
| 0.5 | 10 | 2.5 | 5.0 | 1 | 10 | 5 | 5.0 | 2 | 10 | 10 | 2.0 |
| | | | | 0.5 | 10 | 2.5 | 5.0 | 1 | 10 | 5 | 5.0 |
| | | | | | | | | 0.5 | 10 | 2.5 | 5.0 |

Dutch roll 1 rep/hour
Dutch roll 2 rep/hr
360-deg rolls 0.4 rep/hr

DUTY CYCLES OF VARIOUS AIRPLANE MODELS FOR FLYWHEEL ANALYSIS
 TIME EXCEEDANCE CURVES VERSUS CYCLE AMPLITUDE
 SPECTRUM FOR 3,000 FLIGHT HOURS
 XB-70 PITCHING CYCLES

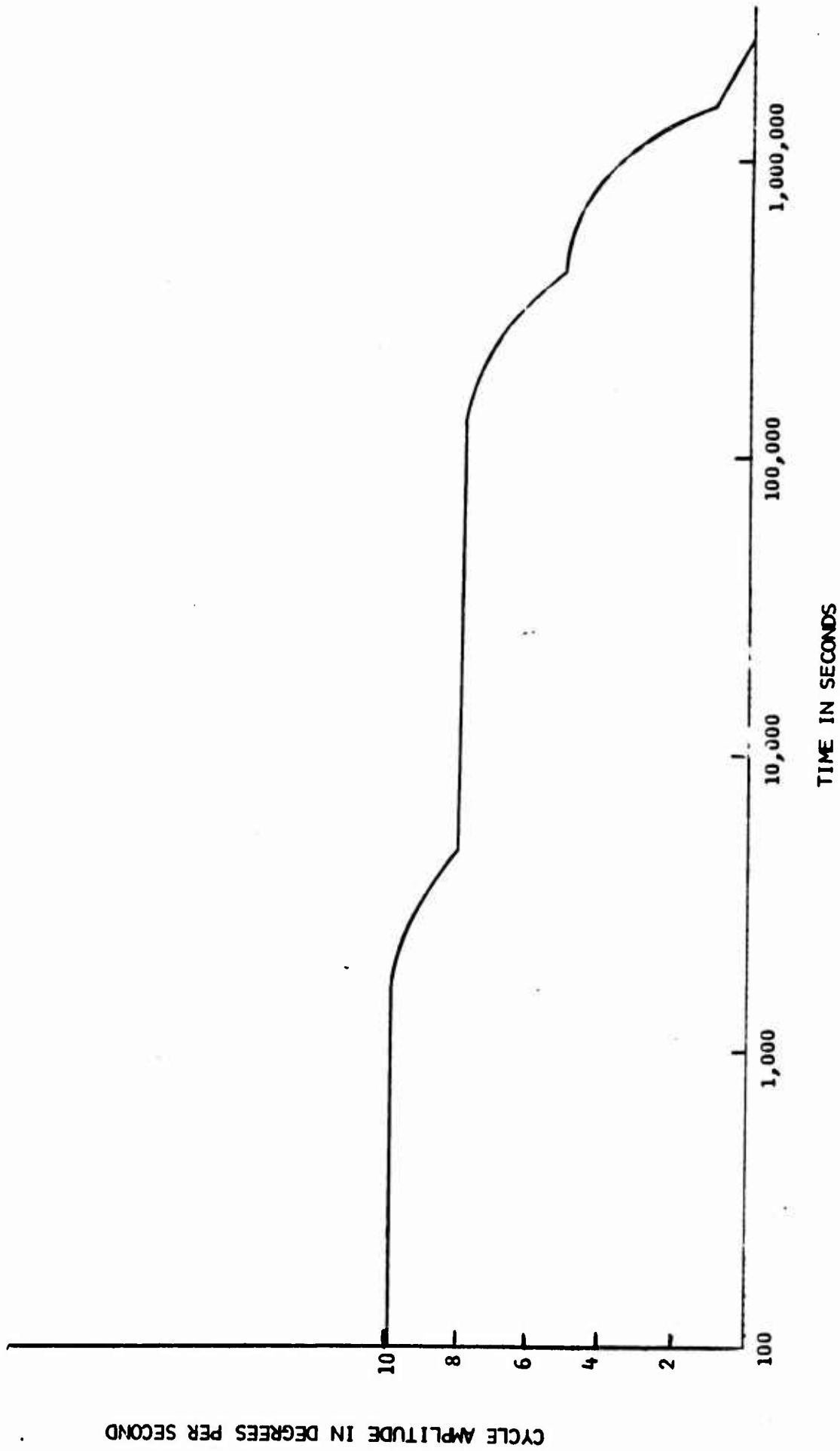

Figure 16. Time Exceedance Curve

DUTY CYCLES OF VARIOUS AIRPLANE MODELS FOR FLYWHEEL ANALYSIS
 TIME EXCEEDANCE CURVES VERSUS CYCLE AMPLITUDE
 SPECTRUM FOR 3,000 FLIGHT HOURS
 XB-70 ROLLING CYCLES

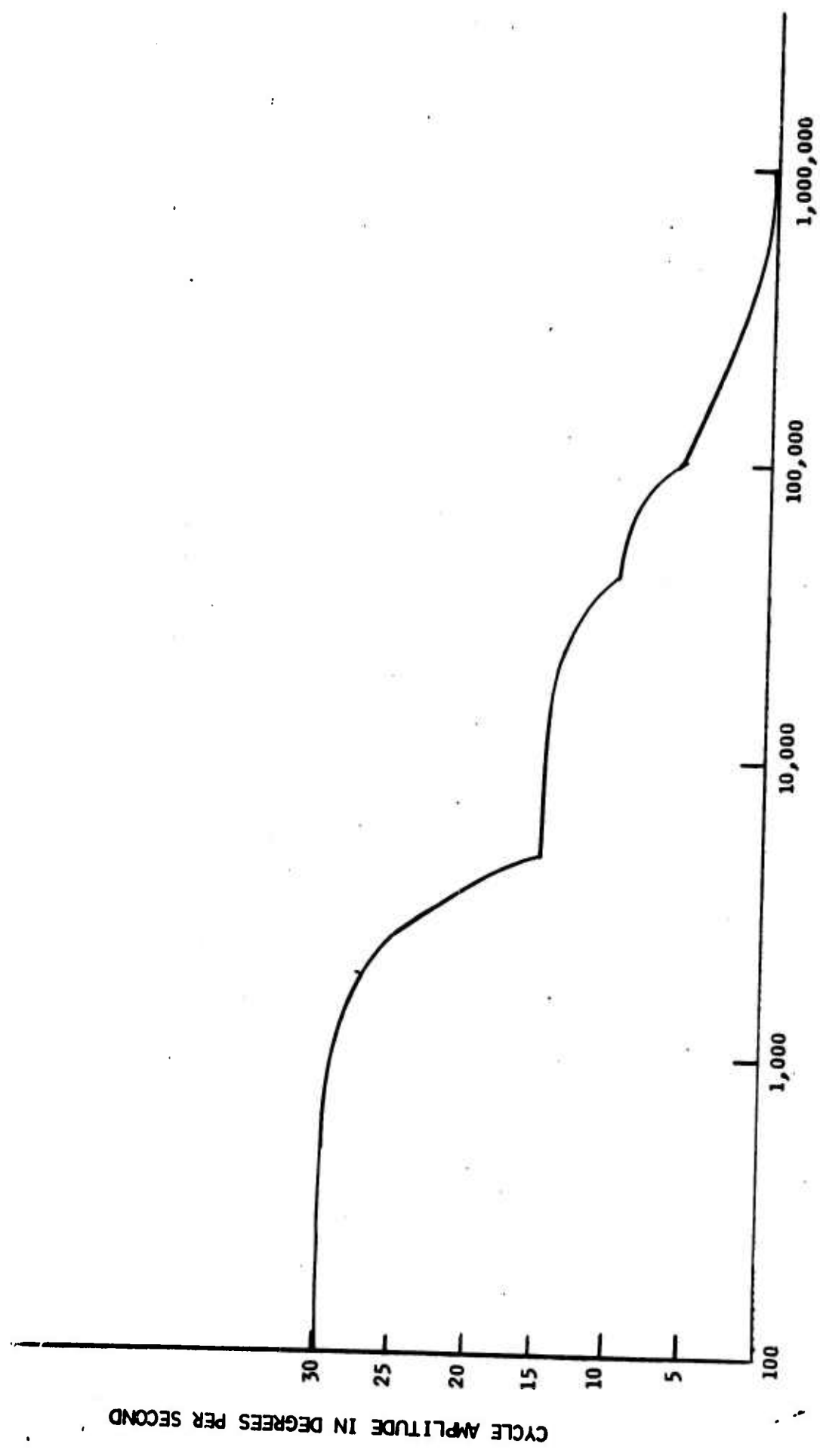
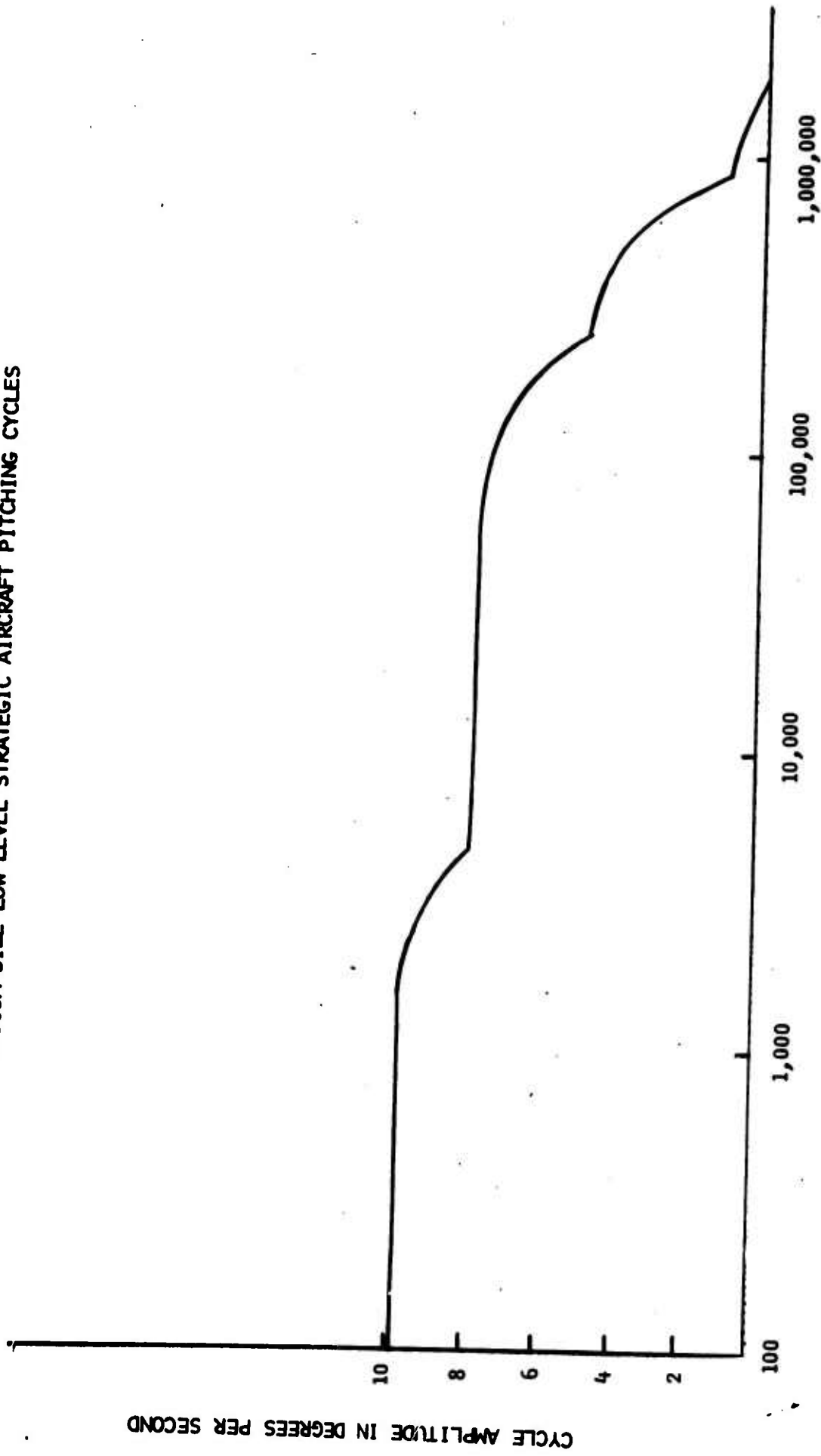

Figure 17. Time Exceedance Curve

DUTY CYCLES OF VARIOUS AIRPLANE MODELS FOR FLYWHEEL ANALYSIS
TIME EXCEEDANCE CURVES VERSUS CYCLE AMPLITUDE
SPECTRUM FOR 3,000 HOURS FLIGHT TIME
MEDIUM SIZE LOW LEVEL STRATEGIC AIRCRAFT PITCHING CYCLES



TIME IN SECONDS
Figure 18. Time Exceedance Curve

DUTY CYCLES OF VARIOUS AIRPLANE MODELS FOR FLYWHEEL ANALYSIS
 TIME EXCEEDANCE CURVES VERSUS CYCLE AMPLITUDE
 SPECTRUM FOR 3,000 FLIGHT HOURS
 MEDIUM SIZE LOW LEVEL STRATEGIC AIRCRAFT ROLLING CYCLES

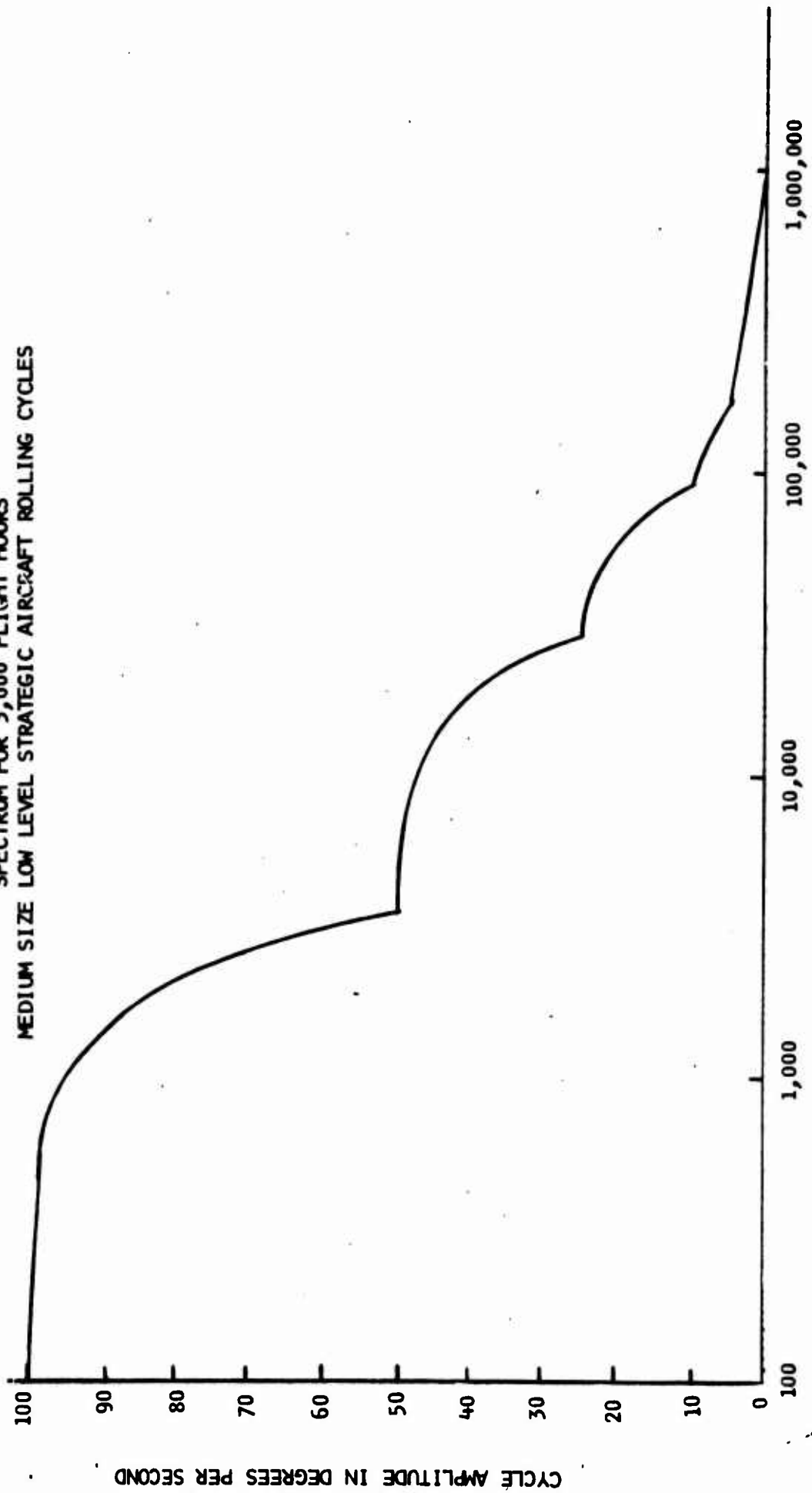

TIME IN SECONDS
 Figure 19. Time Exceedance Curve

DUTY CYCLES OF VARIOUS AIRPLANE MODELS FOR FLYWHEEL ANALYSIS
 TIME EXCEEDANCE CURVES VERSUS CYCLE AMPLITUDE
 SPECTRUM FOR 3,000 FLIGHT HOURS
 FIGHTER-RECONNAISSANCE PITCHING CYCLES

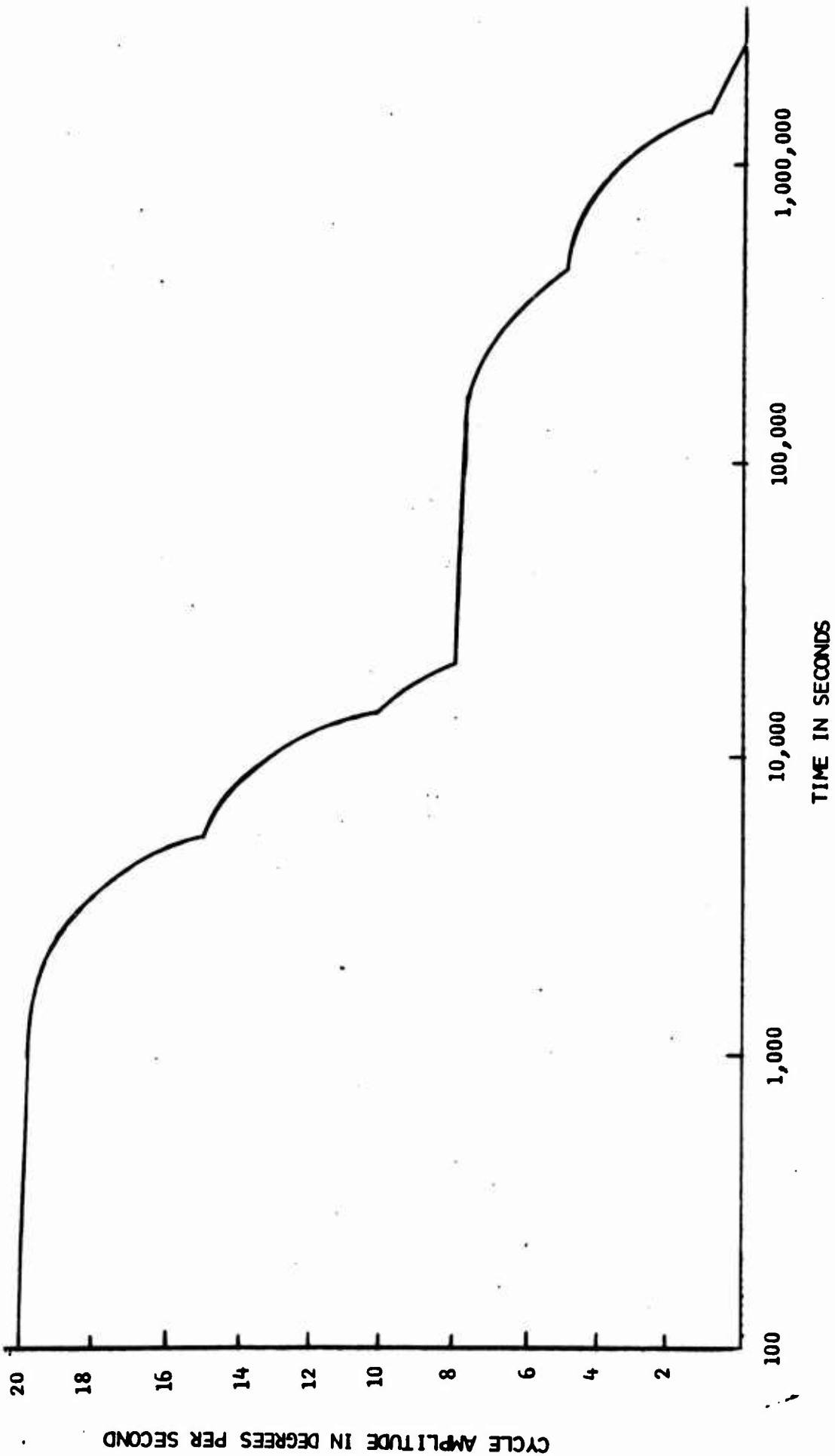

Figure 20. Time Exceedance Curve

DUTY CYCLES OF VARIOUS AIRPLANE MODELS FOR FLYWHEEL ANALYSIS
TIME EXCEEDANCE CURVES VERSUS CYCLE AMPLITUDE
SPECTRUM FOR 3,000 FLIGHT HOURS
FIGHTER-RECONNAISSANCE ROLLING CYCLES

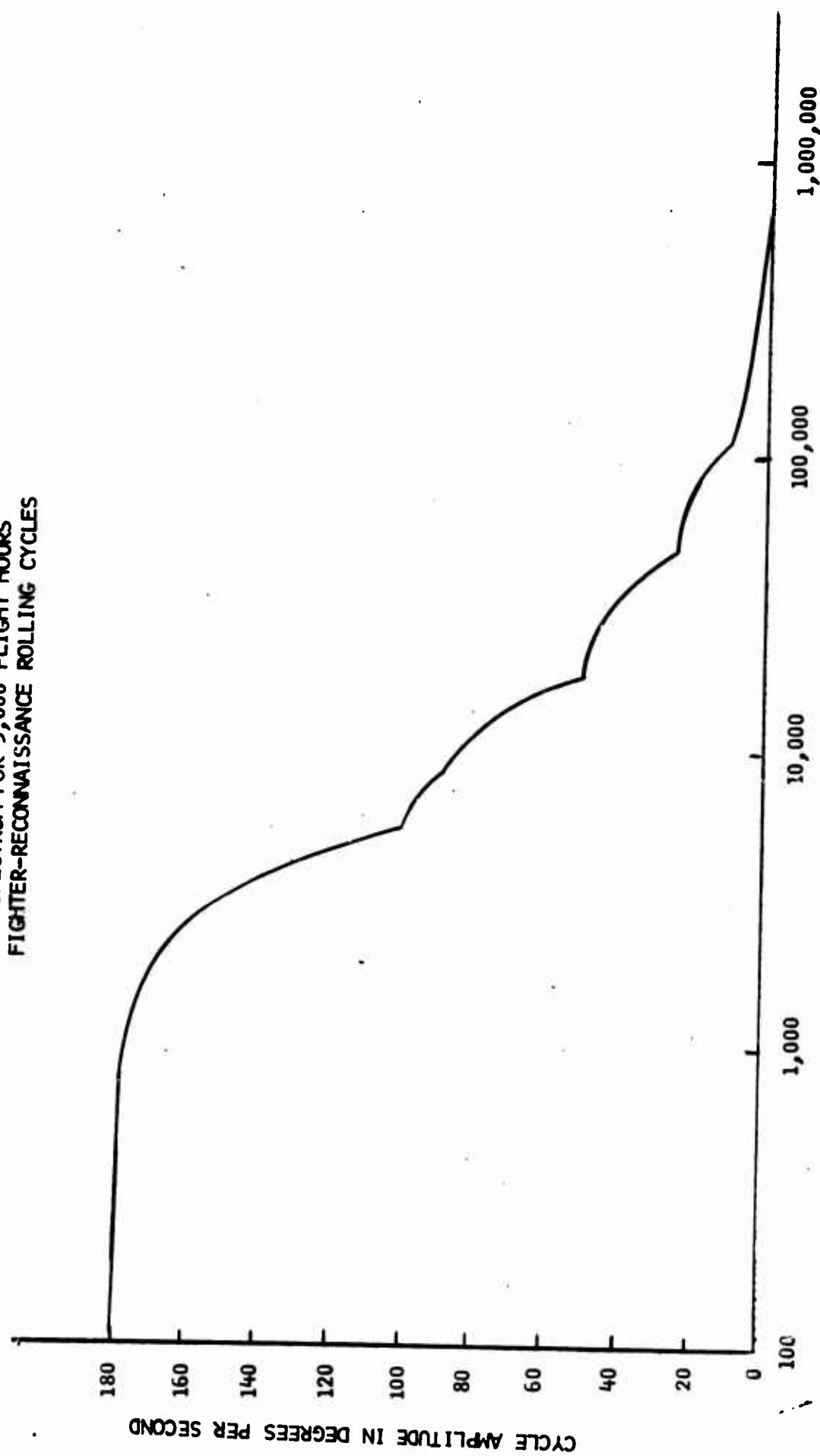

Figure 21. Time Exceedance Curve

As a clarification of the G-load, it should be pointed out that:

1. The G-load never adds algebraically to the precession load except for loads caused by aircraft yaw maneuvers.
2. The precessional loads imposed by yaw maneuvers are negligible. (Since any installation position in an aircraft will always combine them with much larger loads caused by pitch or roll maneuvers, they can be safely neglected.)
3. The G-load varies with the various aircraft maneuvers and aircraft groupings.
4. The G-load adds in a vector quantity for all pitch and roll maneuvers unless the flywheel mounting calls for a vertical axis. In this case, it merely changes the thrust preload on the bearing by adding to one and subtracting from the other.

To satisfactorily account for the above factors, the G-load was added to the precessional load in variable increments arbitrarily chosen, based upon a review of accumulated flight data.

Table VI is basically a listing of the selected test spectrum. It is arranged essentially to allow accomplishment of test objectives in steps which are in ascending order with respect to severity of damage on the bearings, and to give precedence to the fulfillment of XB-70 airplane installation requirements. The test objectives are established considering that the mounting orientation in an airplane will always require that pitch or roll, or both pitch and roll, maneuvers impose precessional loads on the flywheel bearings.

C. TILT TABLE SIMULATOR TESTING

Initial operation of the Tilt Table Simulator substation was begun February 7, 1967. It was planned to increase teststand pressure until the flywheel began to rotate, then gradually increase speed while observing vibration data to determine the frequency, and the magnitude of the resonant points.

When frictional breakout occurred, the speed increased from 0 rpm to over 20,000 rpm and it was found that this was about the minimum speed that could be effectively maintained. This phenomena can be readily explained when it is remembered that it is a characteristic of the design of the New York Airbrake-type motor-pump to display a high breakout friction since the piston shoes do not become floated on a thin film of oil until rotation begins.

Because the speeds between 0 and 20,000 rpm were passed through so quickly, resonant vibration points were observable only as transients. Higher speeds were dwelled upon with sufficient time to establish stabilized conditions where resonant vibration conditions were suspected. The search up to 56,000 rpm was successfully conducted, with a minor delay occurring when 36,000 rpm was reached due to a bearing overheat problem which is described subsequently.

Table VI
TILT TABLE ENDURANCE TEST SPECTRUM

| Test Objective | Tilt Table Rate | Bearing Load | Test Time Increment | Time From Start of Test |
|--|-----------------|--------------|---------------------|-------------------------|
| I XB-70 pitch | 11.7 deg/sec | 54 lb | 38 hr | 38 hr |
| II XB-70 roll | 30.9 deg/sec | 143 lb | .45 hr | 38.45 hr |
| III XB-70 pitch and roll | 30.9 deg/sec | 143 lb | 2.05 hr | 40.5 hr |
| IV Noted* and pitch | 11.7 deg/sec | 54 lb | 0** hr | 40.5 hr |
| V Fighter-Reconnaissance pitch | 23.5 deg/sec | 108 lb | 0** hr | 40.5 hr |
| VI Noted* roll | 101.7 deg/sec | 470 lb | 1.18 hr | 41.68 hr |
| VII Noted* pitch and roll | 101.7 deg/sec | 470 lb | .09 hr | 41.77 hr |
| VIII Fighter-Reconnaissance roll | 182 deg/sec | 838 lb | 1.22 hr | 42.99 hr |
| IX Fighter-Reconnaissance pitch and roll | 182 deg/sec | 838 lb | .02 hr | 43.01 hr |

* Medium size low-level strategic aircraft.

** This objective was satisfied during test objective III in that the total damage accumulated at the end of III resulting from operating the tilt table for 40.5 hours at 30.9 degrees per second exceeds that from the equivalent of 3,000 hours of operation when the flywheel is mounted so as to be subject to pitching only in the types of air vehicle indicated.

This vibration search revealed no resonance conditions of measurable magnitude that could be positively identified by audible changes in pitch or visual observation.

Figure 22 is an expanded trace of substation vibrational accelerations. This particular trace is one taken from accelerometer No. 5, which was monitored at 35,373 rpm. This trace is typical of the highest acceleration encountered during testing while the substation was operating normally. It can be seen that the trace represents a complex combination of accelerations occurring at assorted high frequencies, the sum of which totals approximately 16.6G.

Because this trace represented one of the worst conditions encountered, it was selected for further analysis. Figure 23 is the result of that analysis. This figure was created by running the magnetic tape results from figure 22 through an analyzer having a five-cycle filter bandwidth. The analyzer scanned frequencies from 0 to 3,000 cycles per second. In effect, the analyzer broke the complex trace down into the equivalent sinusoidal vibrations in terms of frequency and "G" amplitude. From this figure it can be seen that the primary contributor to substation vibration is the motor-pump while the flywheel's contribution is nearly negligible.

Although it was originally felt that vibration pickups would provide an excellent indication of imminent bearing failure, actual testing has not proven this to be true. The high level of motor-pump vibrational output shown in figure 23 successfully masks the changes in bearing vibration level. Therefore, the best indicator of imminent bearing failure remains the temperature pickup.

As previously mentioned, the test operation during resonance search was uneventful until 36,000 rpm was approached. At this speed, unacceptable bearing temperature characteristics appeared. The nature of the problem displayed a time-dependent element, i.e., after a few minutes at or near this speed the temperature began to rise with all the characteristics of a runaway temperature condition. Repeated runs to this speed with varied lube oil flows to measure the cooling effect of the oil came up with the same results. The only exception to this rule occurred when a run was made with the gearbox inadvertently evacuated to a low absolute pressure by the scavenge pump. In this case the outboard bearing ran cool. A comparison of the outboard bearing with the inboard bearing (which always ran cool) indicated the condition could be corrected by adding a bearing cavity vent line to supplement the bearing drain line. This conclusion resulted from the consideration of several factors as follows:

1. The bearings, lube jets, slingers and the internal geometry of the inboard and outboard bearing cavities are identical except for the fact that the inboard slinger (in effect an axial turbine) can blow the air and oil mist it draws through the bearing directly into the gearbox.
2. The outboard slinger blows directly at the end cap and the only egress for the oil-air mixture is through a rather small drain line.

GEARBOX VIBRATIONAL DATA RECORD

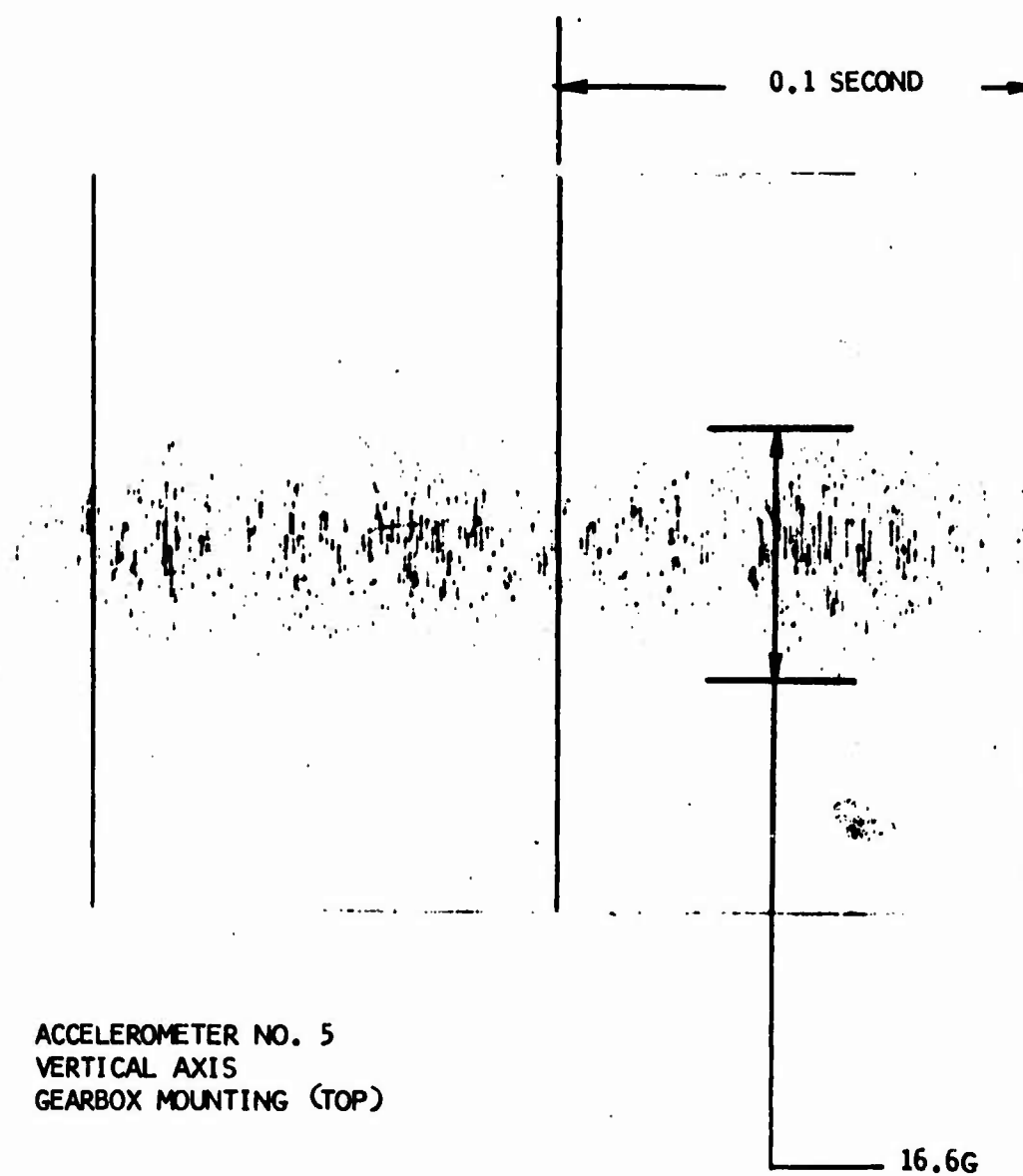
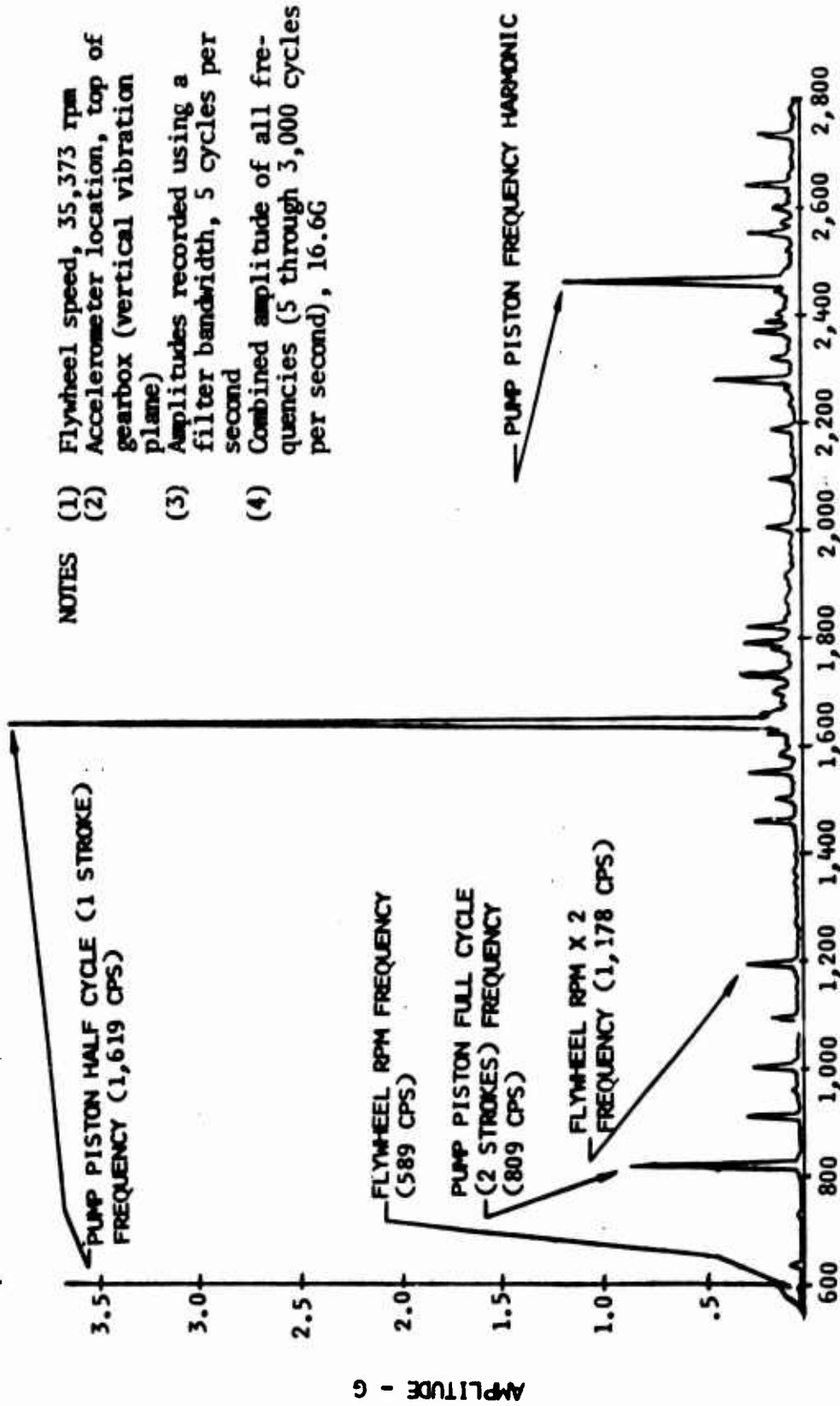

Figure 22. Vibration Trace

EXPANDED VIBRATION DATA RECORD



- NOTES
- (1) Flywheel speed, 35,373 rpm
 - (2) Accelerometer location, top of gearbox (vertical vibration plane)
 - (3) Amplitudes recorded using a filter bandwidth, 5 cycles per second
 - (4) Combined amplitude of all frequencies (5 through 3,000 cycles per second), 16.6G

FREQUENCY - CYCLES PER SECOND

Figure 23. Vibration Analysis

3. Overheat did not occur when the absolute pressure in the bearing cavity was low and the slinger, as a result, was a relatively ineffective air pump.

Based upon the above, it was concluded that the overheating occurred as the result of air recirculation peculiar to the outboard bearing. The air blown by the slinger would find its way back to the low-pressure side of the slinger via the drain passage provided for the carbon face seal coolant oil. This air, already heavily laden with hot oil mist from the bearing, would pick up additional hot oil from the seal and cause the heated and reheated mixture to pass through the bearing a second, third or fourth time. A supplementary effect was to cause the bearing to run flooded, thus generating more heat.

It was correctly concluded that the addition of a vent line would break the recirculating cycle and allow air to enter the cavity tending to help drop the lubrication level. Subsequent operation produced outboard bearing temperatures that were consistent with those of all other gearbox and flywheel bearing temperatures (i.e., 190° to 210° F).

It was noted that when operation was at 52,000 rpm, the flow regulator allowed the motor-pump unit to hunt in 20-second intervals. The flywheel speed varied during this interval from 52,000 rpm to 56,000 rpm. Unsuccessful attempts were made to eliminate the hunting by changing the supply and return pressures.

The motor-pump unit was then cycled to pumping. The resulting slowdown was relatively smooth and quiet. However, toward the end of the cycle, the test stand relief valve started to chatter violently.

A day was spent troubleshooting the relief valve and it was thought that the problem was fixed. However, on the next slowdown cycle the noise and chattering was even more pronounced. Finally, on the third attempted slowdown, the motor-pump destroyed itself. A photograph of the destroyed pump disassembled is shown in figure 24.

At first it was thought that our method of operating the motor-pump during the gradual speed increase incident to resonance search may have initiated the failure. This type of operation involved low inlet pressure (1,500 psi). However, after discussing the failure with New York Airbrake, it was concluded that the failure initiated from a defect in the motor-pump itself. More specifically, it was felt that the failure initiated from gradually-increased binding of a piston which eventually broke that piston's ball end and then complete destruction followed.

Testing was resumed using the XB-70 emergency generator motor, taking advantage of its recirculation loop to perform motor-pump functions with respect to extracting energy from the flywheel. The power losses associated with the recirculation loop consume a modest amount of power. The power consumed was sufficient so that a 15 percent flywheel slowdown occurred in less than 20 seconds. However, it was not considered feasible to further modify the control head so that greater amounts of power could be consumed.

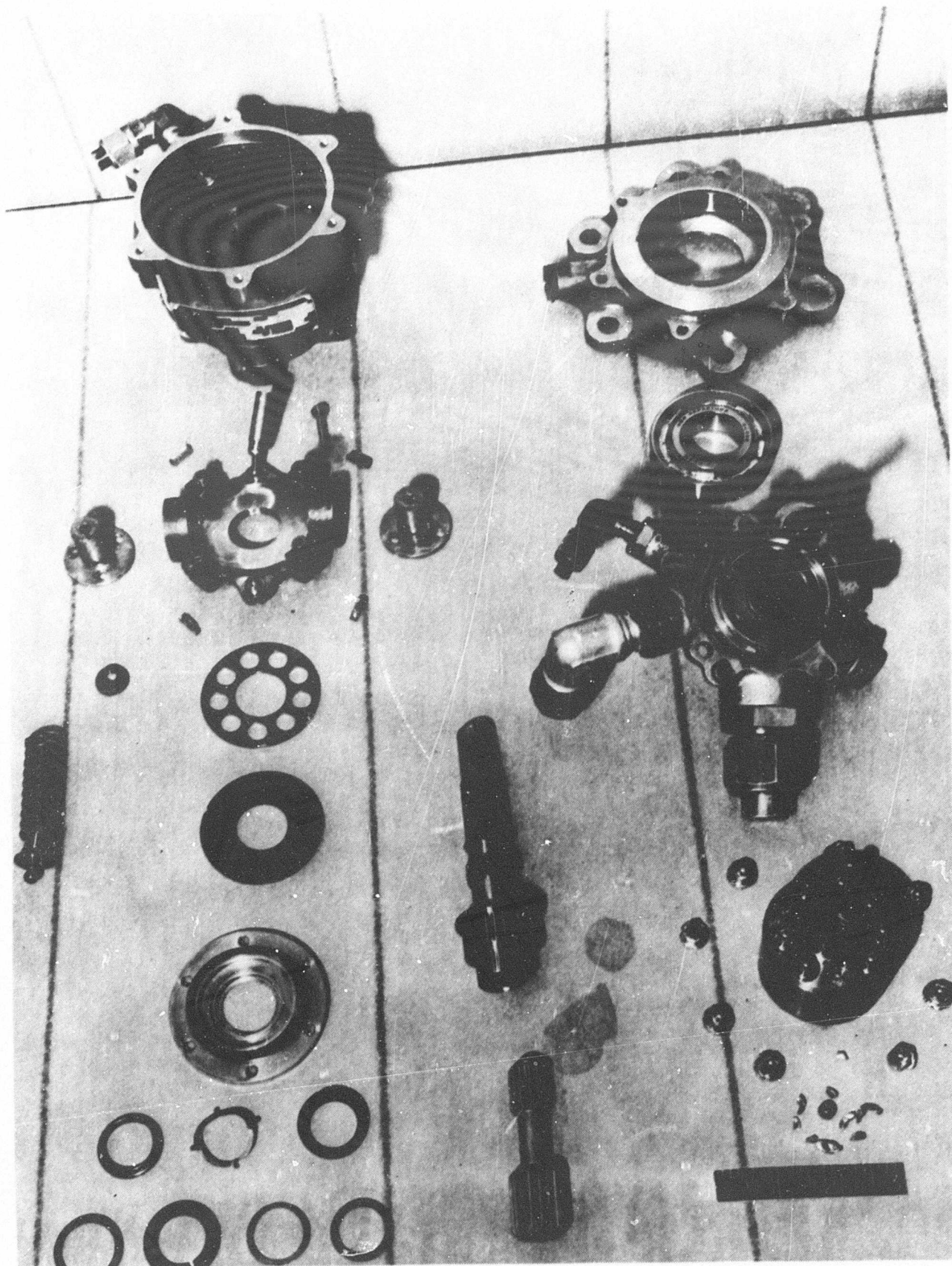

Figure 24. Destroyed Motor-Pump

Recognizing that it is a basic purpose of the tilt table tests to torque load the flywheel while subjecting it to precessional loads, it follows that the reduced slowdown rate and its associated fatigue damage could be compensated for by using increased power for acceleration. To exactly duplicate the torque loading characteristics of the original motor-pump, assuming essentially equal acceleration and deceleration torques, would require a supply pressure of 1,850 psi for the substitute motor-pump. This was determined from the following relationship:

$$3000 \text{ psi} \times \frac{.4 \text{ in.}^3/\text{rev}(\text{Original Motor-Pump Unit})}{.646 \text{ in.}^3/\text{rev}(\text{Substitute Motor Unit})} = 1850 \text{ psi}$$

However, to compensate for the substitute motor-pump's lack of full deceleration torque capabilities, the acceleration torque was increased by raising the supply pressure to 2,000 psi.

The endurance test was begun with the motor-pump set up as just described. The test followed the spectrum of table VI. Approximately 34.5 hours of testing was completed out of 38 hours required for completion of Test Objective I in the spectrum. Table VIII (nine pages) is the recorded data. Table VIII is a summary of calculated results. Figure 25 is a sample data record from which some of the data were taken, and which was used to monitor the performance of the test.

The first 24 hours of testing was conducted with the tilt rate adjusted to slightly less than 12 degrees per second. The tilt rate had some variation throughout the stroke. Maximum tilt rate had a random relationship to instantaneous flywheel speeds, since this was a function of an independent flywheel speedup and slowdown cycle. The net result of these factors was to create bearing precessional loads of a variety of magnitudes. The accumulated data indicated that the average magnitude represented a reduced load on the bearings when compared to the constant 54 pounds called for in the test spectrum.

At this point (24 hours) in the test, a review of the effect of this reduced load was made. It was determined that an increased load of 61 pounds for the remaining 14 hours in Test Objective I would result in a bearing life usage equivalent to the original intent (i.e., that of 38 hours with a 54-pound bearing load).

The actual application of the newly increased rate resulted in a load that fluctuated between 59 and 64 pounds. This load, although it fluctuated, remained more consistent in the remaining portion of the test because the flywheel speedup, slowdown cycles were discontinued.

Shortly before the end of the last full day's testing (30 hours) the vibration traces began to act peculiarly. The test stand was shut down and it was found that several accelerometer leads were loose. After tightening these leads, the test stand was restarted and the vibration traces were much improved; however, they did not return completely to their original characteristics. At the time, the continued peculiarity of the traces was ascribed to faulty pick-ups; however, in retrospect, it is now known that this signaled the start of serious bearing deterioration.

Table VII

TILT TABLE SIMULATOR TEST DATA

Summary Data Sheet No. 1Date: 2-28-67

| Running Time of Test - Hours | 0.5 | 1.0 | 1.5 | 2.0 | 2.5 | 3.0 | 3.5 | 4.0 |
|--|----------|--------|--------|--------|--------|--------|--------|--------|
| Vibration Amp. at Flywheel Bearings - g's | Inboard | 4.1 | 4.1 | 4.1 | 4.0 | 4.1 | 4.1 | 4.1 |
| | Outboard | 3.8 | 3.8 | 3.8 | 3.7 | 3.9 | 3.4 | 3.7 |
| (1) Flywheel Speed at Full Metering-RPM | 52,000 | 52,000 | 52,000 | 52,000 | 52,000 | 52,000 | 52,000 | 52,000 |
| (2) Minimum Speed Attain Under Load-RPM | 44,500 | 44,500 | 44,500 | 44,500 | 44,500 | 44,500 | 44,500 | 44,500 |
| Total Processional Load Cycles | 200 | 410 | 615 | 841 | 1020 | 1231 | 1436 | 1652 |
| Ave. Tilt Table Velocity - deg/sec. | 11.7 | 12.3 | 11.8 | 11.8 | 11.5 | 11.8 | 12.0 | 11.7 |
| Ave. Load on Flywheel Bearings - lbs. | 41 | 40 | 40 | 42 | 41 | 42 | 42 | 41 |
| NO. TEMPERATURE DATA - DEG. F | | | | | | | | |
| 1 Test Pump Inlet | 130 | 135 | 135 | 147 | 138 | 135 | 135 | 133 |
| 2 Test Pump Return | 135 | 140 | 140 | 147 | 148 | 152 | 138 | 138 |
| 3 Test Pump Case Drain | 201 | 205 | 208 | 215 | 200 | 198 | 212 | 208 |
| 4 Main Hyd. Reservoir Supply | 125 | 130 | 130 | 130 | 132 | 130 | 128 | 128 |
| 5 Lube Oil Return | 187 | 195 | 198 | 201 | 203 | 203 | 201 | 203 |
| 6 Lube Oil Suction | 80 | 85 | 88 | 90 | 90 | 90 | 90 | 89 |
| 7 Scavange Oil Return | 130 | 135 | 132 | 135 | 135 | 138 | 132 | 132 |
| 8 Gear Box Bearing Adjacent Pump | 195 | 200 | 200 | 202 | 200 | 200 | 201 | 200 |
| 9 Gear Box Bearing Adjacent Flywheel | 185 | 185 | 185 | 182 | 185 | 185 | 185 | 183 |
| 10 Inboard Flywheel Bearing | 195 | 205 | 208 | 210 | 209 | 208 | 208 | 210 |
| 11 Outboard Flywheel Bearing | 185 | 195 | 195 | 198 | 198 | 198 | 198 | 198 |
| 12 Flywheel Case Housing | 152 | 170 | 172 | 178 | 175 | 178 | 178 | 176 |
| NO. SYSTEM PRESSURE DATA - PSID | | | | | | | | |
| 13 Outboard Flywheel Bearing | 26 | 26 | 26 | 26 | 27 | 27 | 27 | 27 |
| 14 Inboard Flywheel Bearing | 27 | 27 | 27 | 27 | 28 | 28 | 28 | 28 |
| 15 Lube Pump Pressure Port | 68 | 68 | 68 | 68 | 67 | 65 | 65 | 65 |
| 16 Lube Reservoir | 0 | 0 | 0 | 0 | 0 | 0 | 0 | 0 |
| 17 Hyd. Supply Pump Press. Port | 2150 | 2150 | 2150 | 2150 | 2150 | 2150 | 2150 | 2150 |
| 18 Test Motor Press. Port | 2000 | 2000 | 2000 | 2000 | 1980 | 2000 | 1990 | 2000 |
| 19 Test Motor Return Port | 110 | 110 | 110 | 110 | 110 | 110 | 110 | 110 |
| 20 Test Motor Case Drain | 4 | 4 | 4 | 4 | 4 | 4 | 4 | 4 |
| 21 Vacuum at Flywheel Hub - in. Hg | 29.5 | 29.5 | 29.6 | 29.5 | 29.5 | 29.5 | 29.4 | 29.4 |
| 22 Vacuum Across Flywheel Housing - in. Hg (Hub to Tip ΔP) | 1.5 | 1.6 | 1.6 | 1.6 | 1.5 | 1.5 | 1.5 | 1.5 |
| 23 Press. at Flywheel Hub - cm Hg Ab | 2.3 | 2.4 | 2.4 | 2.4 | 2.4 | 2.4 | 2.3 | 2.3 |
| NO. FLUID FLOW DATA - GPM | | | | | | | | |
| 24 Inlet Flow to Motor | 23 | 23 | 23 | 23 | 23 | 23 | 23 | 23 |
| 25 Case Drain Flow of Motor | .2+0.4 | .2-.4 | .2-.4 | .2-.4 | .2-.4 | .2-.4 | .2-.4 | .2-.4 |
| 26 Outboard Bearing Lube Flow cc/min. | 400 | 400 | 400 | 400 | 405 | 405 | 405 | 405 |
| 27 Inboard Bearing Lube Flow cc/min. | 405 | 405 | 405 | 405 | 410 | 410 | 410 | 410 |

Table VII (Continued)

TILT TABLE SIMULATOR TEST DATA

Summary Data Sheet No. 2

Date: 2-28-67

| Running Time of Test - Hours | 4.5 | 5.0 | 5.5 | 6.0 | 6.5 | 7.0 | 7.5 | 8.0 |
|---|----------|--------|--------|--------|--------|--------|--------|--------|
| Vibration Amp. at Flywheel Bearings-g's | Inboard | 4.4 | 4.3 | 4.5 | 4.3 | 4.6 | 4.6 | 4.6 |
| | Outboard | 4.7 | 4.7 | 4.8 | 4.7 | 4.9 | 4.9 | 5.2 |
| (1) Flywheel Speed at Full Motoring-RPM | 52,000 | 52,000 | 52,000 | 52,000 | 52,000 | 52,000 | 52,000 | 52,000 |
| (2) Minimum Speed Attain Under Load-RPM | 44,500 | 44,500 | 44,500 | 44,500 | 44,500 | 44,500 | 44,500 | 44,500 |
| Total Precessional Load Cycles | 1855 | 2080 | 2280 | 2480 | 2680 | 2885 | 3085 | 3294 |
| Ave. Tilt Table Velocity - deg/sec. | 11.9 | 11.6 | 11.7 | 11.2 | 11.6 | 11.6 | 11.6 | 11.6 |
| Ave. Load on Flywheel Bearings - lbs. | 41 | 42 | 41 | 41 | 43 | 42 | 42 | 42 |
| NO. TEMPERATURE DATA - DEG. F | | | | | | | | |
| 1 Test Pump Inlet | 135 | 135 | 135 | 133 | 132 | 131 | 135 | 132 |
| 2 Test Pump Return | 138 | 138 | 138 | 137 | 136 | 133 | 136 | 137 |
| 3 Test Pump Case Drain | 208 | 200 | 205 | 211 | 208 | 210 | 204 | 208 |
| 4 Main Hyd. Reservoir Supply | 128 | 128 | 128 | 128 | 125 | 125 | 125 | 126 |
| 5 Lube Oil Return | 201 | 202 | 204 | 200 | 201 | 200 | 201 | 200 |
| 6 Lube Oil Suction | 89 | 89 | 89 | 90 | 88 | 88 | 88 | 88 |
| 7 Scavange Oil Return | 132 | 133 | 134 | 132 | 130 | 132 | 131 | 130 |
| 8 Gear Box Bearing Adjacent Pump | 200 | 200 | 200 | 200 | 200 | 200 | 201 | 201 |
| 9 Gear Box Bearing Adjacent Flywheel | 185 | 185 | 182 | 180 | 180 | 180 | 182 | 182 |
| 10 Inboard Flywheel Bearing | 210 | 209 | 208 | 204 | 208 | 208 | 207 | 205 |
| 11 Outboard Flywheel Bearing | 198 | 198 | 200 | 201 | 198 | 198 | 199 | 195 |
| 12 Flywheel Case Housing | 178 | 174 | 178 | 175 | 172 | 172 | 175 | 172 |
| NO. SYSTEM PRESSURE DATA - PSIG | | | | | | | | |
| 13 Outboard Flywheel Bearing | 27 | 27 | 27 | 27 | 27 | 27 | 27 | 27 |
| 14 Inboard Flywheel Bearing | 28 | 28 | 28 | 28 | 28 | 28 | 28 | 28 |
| 15 Lube Pump Pressure Port | 68 | 68 | 68 | 68 | 68 | 68 | 68 | 68 |
| 16 Lube Reservoir | 0 | 0 | 0 | 0 | 0 | 0 | 0 | 0 |
| 17 Hyd. Supply Pump Press. Port | 2150 | 2150 | 2150 | 2150 | 2150 | 2150 | 2150 | 2150 |
| 18 Test Motor Press. Port | 2000 | 2000 | 2000 | 2000 | 2000 | 1990 | 2000 | 2000 |
| 19 Test Motor Return Port | 110 | 110 | 110 | 110 | 110 | 110 | 110 | 110 |
| 20 Test Motor Case Drain | 4 | 4 | 4 | 4 | 4 | 4 | 4 | 4 |
| 21 Vacuum at Flywheel Hub - in. Hg | 29.4 | 29.4 | 29.4 | 29.4 | 29.4 | 29.4 | 29.4 | 29.4 |
| (Hub to Tip ΔP) 22 Vacuum Across Flywheel Housing - in. Hg | 1.5 | 1.5 | 1.5 | 1.5 | 1.5 | 1.5 | 1.5 | 1.5 |
| 23 Press. at Flywheel Hub - cm Hg Ab | 2.3 | 2.3 | 2.2 | 2.2 | 2.2 | 2.2 | 2.2 | 2.2 |
| NO. FLUID FLOW DATA - GPM | | | | | | | | |
| 24 Inlet Flow to Motor | 23 | 23 | 23 | 23 | 23 | 23 | 23 | 23 |
| 25 Case Drain Flow of Motor | .2-.4 | .2-.4 | .2-.4 | .2-.4 | .2-.4 | .2-.4 | .2-.4 | .2-.4 |
| 26 Outboard Bearing Lube Flow cc/min | 405 | 405 | 405 | 405 | 405 | 405 | 405 | 405 |
| 27 Inboard Bearing Lube Flow cc/min | 410 | 410 | 410 | 410 | 410 | 410 | 410 | 410 |

Table VII (Continued)

TILT TABLE SIMULATOR TEST DATA

Summary Data Sheet No. 3

Date: 2-28-67

| | | | | | | | | | |
|---|--|--------|--------|--------|--------|--------|--------|--------|--------|
| Running Time of Test - Hours | | 8.5 | 9.0 | 9.5 | 10.0 | 10.5 | 11.0 | 11.5 | 12.0 |
| Vibration Amp. at Flywheel Bearings-g's | Inboard | 4.3 | 4.9 | 5.0 | 4.8 | 5.0 | 5.0 | 4.6 | 4.9 |
| | Outboard | 4.9 | 5.3 | 5.0 | 5.3 | 5.2 | 5.2 | 5.0 | 5.1 |
| (1) Flywheel Speed at Full Motoring-RPM | | 52,000 | 52,000 | 52,000 | 52,000 | 52,000 | 52,000 | 52,000 | 52,000 |
| (2) Minimum Speed Attain Under Load-RPM | | 44,500 | 44,500 | 44,500 | 44,500 | 44,500 | 44,500 | 44,500 | 44,500 |
| Total Precessional Load Cycles | | 3509 | 3722 | 3941 | 4154 | 4380 | 4600 | 4830 | 5050 |
| Ave. Tilt Table Velocity - deg/sec. | | 12.0 | 12.0 | 12.1 | 12.4 | 12.1 | 12.3 | 12.3 | 12.4 |
| Ave. Load on Flywheel Bearings - lbs. | | 41 | 42 | 43 | 44 | 42 | 42 | 43 | 43 |
| NO. TEMPERATURE DATA - DEG. F | | | | | | | | | |
| 1 | Test Pump Inlet | 132 | 132 | 133 | 134 | 132 | 132 | 131 | 131 |
| 2 | Test Pump Return | 136 | 133 | 138 | 138 | 133 | 136 | 135 | 136 |
| 3 | Test Pump Case Drain | 210 | 212 | 201 | 210 | 214 | 201 | 208 | 208 |
| 4 | Main Hyd. Reservoir Supply | 126 | 128 | 126 | 128 | 128 | 125 | 122 | 124 |
| 5 | Lube Oil Return | 202 | 205 | 202 | 202 | 205 | 203 | 205 | 203 |
| 6 | Lube Oil Suction | 88 | 88 | 89 | 89 | 88 | 88 | 88 | 85 |
| 7 | Scavange Oil Return | 129 | 130 | 131 | 132 | 131 | 130 | 130 | 128 |
| 8 | Gear Box Bearing Adjacent Pump | 202 | 204 | 201 | 204 | 202 | 202 | 204 | 202 |
| 9 | Gear Box Bearing Adjacent Flywheel | 183 | 185 | 185 | 184 | 185 | 183 | 184 | 182 |
| 10 | Inboard Flywheel Bearing | 207 | 208 | 208 | 210 | 209 | 209 | 210 | 208 |
| 11 | Outboard Flywheel Bearing | 191 | 198 | 198 | 198 | 198 | 198 | 198 | 198 |
| 12 | Flywheel Case Housing | 172 | 171 | 171 | 171 | 172 | 171 | 171 | 170 |
| NO. SYSTEM PRESSURE DATA - PSID | | | | | | | | | |
| 13 | Outboard Flywheel Bearing | 27 | 27 | 27 | 27 | 27 | 28 | 28 | 28 |
| 14 | Inboard Flywheel Bearing | 28 | 28 | 28 | 28 | 28 | 28 | 28 | 28 |
| 15 | Lube Pump Pressure Port | 68 | 68 | 68 | 68 | 68 | 68 | 68 | 68 |
| 16 | Lube Reservoir | 0 | 0 | 0 | 0 | 0 | 0 | 0 | 0 |
| 17 | Hyd. Supply Pump Press. Port | 2150 | 2150 | 2150 | 2150 | 2150 | 2150 | 2150 | 2150 |
| 18 | Test Motor Press. Port | 1990 | 1990 | 2000 | 2000 | 2000 | 2000 | 2000 | 2000 |
| 19 | Test Motor Return Port | 110 | 110 | 110 | 110 | 110 | 110 | 110 | 110 |
| 20 | Test Motor Case Drain | 4 | 4 | 4 | 4 | 4 | 4 | 4 | 4 |
| 21 | Vacuum at Flywheel Hub - in. Hg | 29.4 | 29.4 | 29.4 | 29.4 | 29.4 | 29.4 | 29.4 | 29.4 |
| 22 | Vacuum ^(Hub to TIP ΔP) Across Flywheel Housing - in. Hg | 1.5 | 1.5 | 1.5 | 1.4 | 1.4 | 1.4 | 1.4 | 1.4 |
| 23 | Press. at Flywheel Hub - cm. Hg Ab | 2.2 | 2.2 | 2.2 | 2.2 | 2.3 | 2.3 | 2.3 | 2.3 |
| NO. FLUID FLOW DATA - GPM | | | | | | | | | |
| 24 | Inlet Flow to Motor | 23 | 23 | 23 | 23 | 23 | 23 | 23 | 23 |
| 25 | Case Drain Flow of Motor | .2-.4 | .2-.4 | .2-.4 | .2-.4 | .2-.4 | .2-.4 | .2-.4 | .2-.4 |
| 26 | Outboard Bearing Lube Flow cc/min | 405 | 405 | 405 | 405 | 405 | 410 | 410 | 410 |
| 27 | Inboard Bearing Lube Flow cc/min | 410 | 410 | 410 | 410 | 410 | 410 | 410 | 410 |

Table VII (Continued)

TILT TABLE SIMULATOR TEST DATA

| Summary Data Sheet No. 4 | | Date: 3-2-01 | | | | | | | |
|---|--|--------------|--------|--------|--------|--------|--------|--------|--------|
| Running Time of Test - Hours | | 12.5 | 13.0 | *13.5 | 14.0 | 14.5 | 15.0 | 15.5 | 16.0 |
| Vibration Amp. at Flywheel Bearings-g's | Inboard | 4.8 | 4.9 | - | - | - | - | - | - |
| | Outboard | 5.3 | 5.3 | - | - | - | - | - | - |
| (1) Flywheel Speed at Full Motoring-RPM | | 52,000 | 52,000 | 52,000 | 52,000 | 52,000 | 52,000 | 52,000 | 52,000 |
| (2) Minimum Speed Attain Under Load-RPM | | 44,500 | 44,500 | 44,500 | 44,500 | 44,500 | 44,500 | 44,500 | 44,500 |
| Total Precessional Load Cycles | | 5262 | 5487 | 5685 | 5886 | 6105 | 6322 | 6530 | 6744 |
| Ave. Tilt Table Velocity - deg/sec. | | 12.0 | 11.7 | 11.9 | 11.9 | 12.0 | 11.9 | 11.9 | 11.7 |
| Ave. Load on Flywheel Bearings - lbs. | | 41 | 41 | 42 | 44 | 45 | 42 | 41 | 43 |
| NO. TEMPERATURE DATA - DEG. F | | | | | | | | | |
| 1 | Test Pump Inlet | 131 | 131 | 115 | 130 | 132 | 133 | 130 | 130 |
| 2 | Test Pump Return | 136 | 135 | 116 | 130 | 136 | 135 | 130 | 135 |
| 3 | Test Pump Case Drain | 198 | 208 | 210 | 212 | 209 | 204 | 213 | 200 |
| 4 | Main Hyd. Reservoir Supply | 123 | 124 | 120 | 125 | 125 | 123 | 125 | 120 |
| 5 | Lube Oil Return | 203 | 204 | 200 | 210 | 210 | 210 | 208 | 207 |
| 6 | Lube Oil Suction | 85 | 85 | 85 | 90 | 90 | 90 | 88 | 88 |
| 7 | Scavange Oil Return | 131 | 130 | 125 | 130 | 128 | 130 | 128 | 130 |
| 8 | Gear Box Bearing Adjacent Pump | 200 | 200 | 195 | 200 | 200 | 200 | 200 | 199 |
| 9 | Gear Box Bearing Adjacent Flywheel | 180 | 182 | 175 | 180 | 182 | 183 | 180 | 180 |
| 10 | Inboard Flywheel Bearing | 209 | 206 | 195 | 205 | 208 | 208 | 207 | 205 |
| 11 | Outboard Flywheel Bearing | 198 | 198 | 195 | 205 | 207 | 205 | 205 | 200 |
| 12 | Flywheel Case Housing | 170 | 170 | 160 | 173 | 178 | 176 | 175 | 175 |
| NO. SYSTEM PRESSURE DATA - PSIG | | | | | | | | | |
| 13 | Outboard Flywheel Bearing | 28 | 28 | 23 | 24 | 24 | 24 | 24 | 24 |
| 14 | Inboard Flywheel Bearing | 28 | 28 | 23 | 23 | 25 | 26 | 26 | 26 |
| 15 | Lube Pump Pressure Port | 68 | 68 | 63 | 63 | 65 | 60 | 60 | 60 |
| 16 | Lube Reservoir | 0 | 0 | 0 | 0 | 0 | 0 | 0 | 0 |
| 17 | Hyd. Supply Pump Press. Port | 2150 | 2150 | 2150 | 2150 | 2150 | 2150 | 2150 | 2150 |
| 18 | Test Motor Press. Port | 2000 | 2000 | 2000 | 2000 | 2000 | 2000 | 2000 | 2000 |
| 19 | Test Motor Return Port | 110 | 110 | 110 | 110 | 110 | 110 | 110 | 110 |
| 20 | Test Motor Case Drain | 4 | 4 | 4 | 4 | 4 | 4 | 4 | 4 |
| 21 | Vacuum at Flywheel Hub - in. Hg | 29.4 | 29.4 | 29.0 | 29.0 | 28.9 | 28.7 | 28.8 | 28.7 |
| 22 | (Hub to Tip ΔP) Vacuum Across Flywheel Housing - in. Hg | 1.4 | 1.4 | 0.8 | 0.8 | 0.8 | 0.7 | 0.8 | 0.7 |
| 23 | Press. at Flywheel Hub - cm Hg Ab | 2.3 | 2.3 | 3.5 | 3.4 | 3.4 | 3.6 | 3.5 | 3.5 |
| NO. FLUID FLOW DATA - GPM | | | | | | | | | |
| 24 | Inlet Flow to Motor | 23 | 23 | 23 | 23 | 23 | 23 | 23 | 23 |
| 25 | Case Drain Flow of Motor | .2-.4 | .2-.4 | .2-.4 | .2-.4 | .2-.4 | .2-.4 | .2-.4 | .2-.4 |
| 26 | Outboard Bearing Lube Flow cc/min | 410 | 410 | 380 | 390 | 390 | 390 | 390 | 390 |
| 27 | Inboard Bearing Lube Flow cc/min | 410 | 410 | 380 | 395 | 405 | 405 | 405 | 450 |

*Start of a new days testing.

Table VII (Continued)

TILT TABLE SIMULATOR TEST DATA

Summary Data Sheet No. 5

Date: 3-1-67

| Running Time of Test - Hours | 16.5 | 17.0 | 17.5 | 18.0 | 18.5 | 19.0 | 19.5 | 20.0 |
|--|----------|--------|--------|--------|--------|--------|--------|--------|
| Vibration Amp. at Flywheel Bearings-g's | Inboard | - | - | - | - | - | - | - |
| | Outboard | - | - | - | - | - | - | - |
| (1) Flywheel Speed at Full Motoring-RPM | 52,000 | 52,000 | 52,000 | 52,000 | 52,000 | 52,000 | 52,000 | 52,000 |
| (2) Minimum Speed Attain Under Load-RPM | 44,500 | 44,500 | 44,500 | 44,500 | 44,500 | 44,500 | 44,500 | 44,500 |
| Total Precessional Load Cycles | 6950 | 7152 | 7363 | 7575 | 7792 | 8005 | 8224 | 8440 |
| Ave. Tilt Table Velocity - deg/sec. | 11.6 | 11.7 | 11.5 | 11.7 | 11.9 | 11.8 | 11.8 | 11.5 |
| Ave. Load on Flywheel Bearings - lbs. | 42 | 43 | 42 | 43 | 41 | 42 | 41 | 42 |
| NO. TEMPERATURE DATA - DEG. F | | | | | | | | |
| 1 Test Pump Inlet | 133 | 130 | 132 | 130 | 134 | 133 | 132 | 133 |
| 2 Test Pump Return | 135 | 130 | 135 | 135 | 135 | 137 | 133 | 137 |
| 3 Test Pump Case Drain | 202 | 215 | 203 | 212 | 215 | 210 | 215 | 212 |
| 4 Main Hyd. Reservoir Supply | 123 | 125 | 125 | 125 | 126 | 127 | 126 | 127 |
| 5 Lube Oil Return | 203 | 203 | 203 | 202 | 203 | 203 | 202 | 203 |
| 6 Lube Oil Suction | 88 | 88 | 88 | 88 | 88 | 88 | 88 | 88 |
| 7 Scavange Oil Return | 128 | 128 | 128 | 128 | 130 | 130 | 130 | 128 |
| 8 Gear Box Bearing Adjacent Pump | 197 | 197 | 197 | 196 | 196 | 200 | 197 | 198 |
| 9 Gear Box Bearing Adjacent Flywheel | 180 | 180 | 180 | 180 | 180 | 180 | 180 | 180 |
| 10 Inboard Flywheel Bearing | 200 | 202 | 198 | 200 | 203 | 200 | 202 | 200 |
| 11 Outboard Flywheel Bearing | 198 | 200 | 197 | 195 | 198 | 197 | 197 | 198 |
| 12 Flywheel Case Housing | 175 | 170 | 170 | 170 | 170 | 170 | 170 | 168 |
| NO. SYSTEM PRESSURE DATA - PSIG | | | | | | | | |
| 13 Outboard Flywheel Bearing | 25 | 25 | 24 | 26 | 26 | 25 | 27 | 26 |
| 14 Inboard Flywheel Bearing | 26 | 25 | 24 | 25 | 25 | 24 | 26 | 25 |
| 15 Lube Pump Pressure Port | 66 | 65 | 66 | 63 | 67 | 62 | 65 | 63 |
| 16 Lube Reservoir | 0 | 0 | 0 | 0 | 0 | 0 | 0 | 0 |
| 17 Hyd. Supply Pump Press. Port | 2150 | 2150 | 2150 | 2150 | 2150 | 2150 | 2150 | 2150 |
| 18 Test Motor Press. Port | 2000 | 2000 | 2000 | 2000 | 2000 | 2000 | 2000 | 2000 |
| 19 Test Motor Return Port | 110 | 110 | 110 | 115 | 115 | 115 | 115 | 115 |
| 20 Test Motor Case Drain | 4 | 4 | 4 | 4 | 4 | 4 | 4 | 4 |
| 21 Vacuum at Flywheel Hub - in. Hg | 28.9 | 28.9 | 28.9 | 28.9 | 28.9 | 28.9 | 28.9 | 28.8 |
| (Hub to Tip ΔP) 22 Vacuum Across Flywheel Housing - in. Hg | 0.9 | 0.9 | 0.9 | 0.9 | 0.9 | 0.9 | 0.9 | 0.8 |
| 23 Press. at Flywheel Hub - cm Hg Abs | 3.1 | 3.1 | 3.1 | 3.1 | 3.1 | 3.1 | 3.1 | 3.2 |
| NO. FLUID FLOW DATA - GPM | | | | | | | | |
| 24 Inlet Flow to Motor | 23 | 23 | 23 | 23 | 23 | 23 | 23 | 23 |
| 25 Case Drain Flow of Motor | .2-.5 | .2-.5 | .2-.5 | .2-.5 | .2-.5 | .2-.5 | .2-.5 | .2-.5 |
| 26 Outboard Bearing Lube Flow cc/min | 395 | 395 | 390 | 405 | 405 | 395 | 410 | 405 |
| 27 Inboard Bearing Lube Flow cc/min | 405 | 395 | 390 | 395 | 395 | 390 | 405 | 395 |

Table VII (Continued)

TILT TABLE SIMULATOR TEST DATA

| Summary Data Sheet No. <u>6</u> | | Date: <u>3-1-67</u> | | | | | | | | |
|---|---|---------------------|--------|--------|--------|--------|--------|--------|--------|--|
| Running Time of Test - Hours | | 20.5 | 21.0 | 21.5 | 22.0 | 22.5 | 23.0 | 23.5 | 24.0 | |
| Vibration Amp. at Flywheel Bearings-g's | Inboard | - | - | - | - | - | - | - | - | |
| | Outboard | - | - | - | - | - | - | - | - | |
| (1) Flywheel Speed at Full Motoring-RPM | | 52,000 | 52,000 | 52,000 | 52,000 | 52,000 | 52,000 | 52,000 | 52,000 | |
| (2) Minimum Speed Attain Under Load-RPM | | 44,500 | 44,500 | 44,500 | 44,500 | 44,500 | 44,500 | 44,500 | 44,500 | |
| Total Precessional Load Cycles | | 8676 | 8866 | 9088 | 9302 | 9516 | 9733 | 9950 | 10167 | |
| Ave. Tilt Table Velocity - deg/sec. | | 11.7 | 11.8 | 12.1 | 11.9 | 12.0 | 12.1 | 11.8 | 11.6 | |
| Ave. Load on Flywheel Bearings - lbs. | | 42 | 44 | 42 | 43 | 42 | 42 | 42 | 43 | |
| NO. TEMPERATURE DATA - DEG. F | | | | | | | | | | |
| 1 | Test Pump Inlet | 135 | 134 | 135 | 135 | 135 | 135 | 137 | 130 | |
| 2 | Test Pump Return | 136 | 138 | 138 | 140 | 138 | 138 | 138 | 135 | |
| 3 | Test Pump Case Drain | 215 | 215 | 215 | 215 | 209 | 210 | 215 | 207 | |
| 4 | Main Hyd. Reservoir Supply | 130 | 128 | 130 | 133 | 128 | 132 | 134 | 125 | |
| 5 | Lube Oil Return | 205 | 210 | 205 | 208 | 208 | 210 | 206 | 200 | |
| 6 | Lube Oil Suction | 88 | 90 | 90 | 88 | 88 | 90 | 90 | 88 | |
| 7 | Scavange Oil Return | 130 | 128 | 130 | 128 | 128 | 127 | 130 | 126 | |
| 8 | Gear Box Bearing Adjacent Pump | 200 | 205 | 202 | 204 | 204 | 202 | 203 | 190 | |
| 9 | Gear Box Bearing Adjacent Flywheel | 180 | 184 | 185 | 183 | 180 | 180 | 183 | 175 | |
| 10 | Inboard Flywheel Bearing | 202 | 210 | 210 | 208 | 206 | 208 | 207 | 194 | |
| 11 | Outboard Flywheel Bearing | 198 | 205 | 205 | 204 | 202 | 205 | 205 | 194 | |
| 12 | Flywheel Case Housing | 170 | 170 | 170 | 169 | 168 | 170 | 170 | 162 | |
| NO. SYSTEM PRESSURE DATA - PSIG | | | | | | | | | | |
| 13 | Outboard Flywheel Bearing | 26 | 27 | 28 | 26 | 26 | 26 | 24 | 24 | |
| 14 | Inboard Flywheel Bearing | 25 | 26 | 27 | 25 | 23 | 25 | 23 | 23 | |
| 15 | Lube Pump Pressure Port | 65 | 67 | 68 | 67 | 67 | 67 | 65 | 68 | |
| 16 | Lube Reservoir | 0 | 0 | 0 | 0 | 0 | 0 | 0 | 0 | |
| 17 | Hyd. Supply Pump Press. Port | 2150 | 2150 | 2150 | 2150 | 2150 | 2150 | 2150 | 2150 | |
| 18 | Test Motor Press. Port | 2000 | 2000 | 2000 | 2000 | 2000 | 2000 | 2000 | 2000 | |
| 19 | Test Motor Return Port | 115 | 115 | 115 | 115 | 115 | 115 | 115 | 115 | |
| 20 | Test Motor Case Drain | 4 | 4 | 4 | 4 | 4 | 4 | 4 | 4 | |
| 21 | Vacuum at Flywheel Hub - in. Hg | 28.8 | 28.9 | 28.8 | 29.0 | 28.9 | 28.9 | 29.0 | 28.9 | |
| 22 | (Hub to Tip ΔP) Vacuum Across Flywheel Housing - in. Hg | 0.8 | 0.8 | 0.8 | 0.8 | 0.8 | 0.8 | 0.8 | 0.8 | |
| 23 | Press at Flywheel Hub - cm Hg Ab | 3.2 | 3.2 | 3.2 | 3.0 | 3.0 | 3.0 | 3.0 | 3.0 | |
| NO. FLUID FLOW DATA - GPM | | | | | | | | | | |
| 24 | Inlet Flow to Motor | 23 | 23 | 23 | 23 | 23 | 23 | 23 | 23 | |
| 25 | Case Drain Flow of Motor | .2-.4 | .2-.4 | .2-.4 | .2-.4 | .2-.4 | .2-.4 | .2-.4 | .2-.4 | |
| 26 | Outboard Bearing Lube Flow cc/min | 405 | 410 | 420 | 405 | 405 | 405 | 385 | 385 | |
| 27 | Inboard Bearing Lube Flow | 395 | 405 | 405 | 395 | 360 | 395 | 375 | 375 | |

Table VII (Continued)

TILT TABLE SIMULATOR TEST DATA

| Summary Data Sheet No. 7 | | Date: 3-2-67 | | | | | | | |
|---|--|--------------|--------|--------|--------|--------|--------|--------|--------|
| Running Time of Test - Hours | | *24.5 | 25.0 | 25.5 | 26.0 | 26.5 | 27.0 | 27.5 | 28.0 |
| Vibration Amp. at Flywheel Bearings g's | Inboard | - | - | - | - | - | - | - | - |
| | Outboard | - | - | - | - | - | - | - | - |
| (1) Flywheel Speed at Full Motoring-RPM | | 52,000 | 52,000 | 52,000 | 52,000 | 52,000 | 52,000 | 52,000 | 52,000 |
| (2) Minimum Speed Attain Under Load-RPM | | | | | | | | | |
| Total Precessional Load Cycles | | 10330 | 10550 | 10802 | 11057 | 11310 | 11330 | 11808 | 12060 |
| Ave. Tilt Table Velocity - deg/sec. | | 14.4 | 14.1 | 14.1 | 14.1 | 14.3 | 14.1 | 14.0 | 13.6 |
| Ave. Load on Flywheel Bearings - lbs. | | 62 | 60 | 61 | 60 | 60 | 59 | 59 | 58 |
| NO. TEMPERATURE DATA - DEG. F | | | | | | | | | |
| 1 | Test Pump Inlet | 118 | 126 | 123 | 128 | 127 | 127 | 129 | 129 |
| 2 | Test Pump Return | 123 | 127 | 126 | 129 | 128 | 128 | 129 | 129 |
| 3 | Test Pump Case Drain | 196 | 200 | 200 | 197 | 200 | 200 | 198 | 198 |
| 4 | Main Hyd. Reservoir Supply | 111 | 115 | 120 | 116 | 115 | 115 | 115 | 115 |
| 5 | Lube Oil Return | 205 | 220 | 220 | 220 | 223 | 220 | 222 | 222 |
| 6 | Lube Oil Suction | 77 | 80 | 75 | 87 | 86 | 88 | 89 | 89 |
| 7 | Scavange Oil Return | 123 | 130 | 137 | 133 | 134 | 133 | 132 | 132 |
| 8 | Gear Box Bearing Adjacent Pump | 206 | 215 | 212 | 215 | 217 | 217 | 213 | 215 |
| 9 | Gear Box Bearing Adjacent Flywheel | 182 | 187 | 188 | 187 | 187 | 187 | 185 | 186 |
| 10 | Inboard Flywheel Bearing | 207 | 215 | 220 | 217 | 220 | 218 | 222 | 222 |
| 11 | Outboard Flywheel Bearing | 200 | 215 | 213 | 214 | 215 | 214 | 212 | 212 |
| 12 | Flywheel Case Housing | 157 | 170 | 180 | 180 | 180 | 180 | 180 | 179 |
| NO. SYSTEM PRESSURE DATA - PSIG | | | | | | | | | |
| 13 | Outboard Flywheel Bearing | 19 | 26 | 26 | 26 | 26 | 26 | 26 | 26 |
| 14 | Inboard Flywheel Bearing | 19 | 26 | 26 | 26 | 27 | 27 | 27 | 27 |
| 15 | Lube Pump Pressure Port | 61 | 59 | 60 | 59 | 59 | 60 | 59 | 59 |
| 16 | Lube Reservoir | 0 | 0 | 0 | 0 | 0 | 0 | 0 | 0 |
| 17 | Hyd. Supply Pump Press. Port | 2000 | 1990 | 1990 | 1990 | 1990 | 1990 | 1990 | 1990 |
| 18 | Test Motor Press. Port | 2000 | 1990 | 1990 | 1990 | 1990 | 1990 | 1990 | 1990 |
| 19 | Test Motor Return Port | 120 | 120 | 120 | 120 | 115 | 115 | 115 | 115 |
| 20 | Test Motor Case Drain | 2 | 2 | 2 | 2 | 2 | 2 | 2 | 2 |
| 21 | Vacuum at Flywheel Hub - in. Hg | 29.1 | 29.1 | 29.0 | 28.9 | 29.0 | 29.0 | 28.9 | 29.0 |
| 22 | (Hub to Tip ΔP) Vacuum Across Flywheel Housing - in. Hg | 0.6 | 0.6 | 0.6 | 0.5 | 0.6 | 0.6 | 0.5 | 0.6 |
| 23 | Press at Flywheel Hub - cm Hg Ab | 2.3 | 2.5 | 2.7 | 2.8 | 2.6 | 2.6 | 2.7 | 2.7 |
| NO. FLUID FLOW DATA - GPM | | | | | | | | | |
| 24 | Inlet Flow to Motor | 23 | 23 | 23 | 23 | 23 | 23 | 23 | 23 |
| 25 | Case Drain Flow of Motor | .2 | .2 | .2 | .2 | .2 | .2 | .2 | .2 |
| 26 | Outboard Bearing Lube Flow cc/min | 340 | 405 | 405 | 405 | 405 | 405 | 405 | 405 |
| 27 | Inboard Bearing Lube Flow cc/min | 340 | 405 | 405 | 405 | 415 | 415 | 415 | 415 |

Table VII (Continued)

TILT TABLE SIMULATOR TEST DATA

Summary Data Sheet No. 8

Date: 3-2-67

| Running Time of Test - Hours | 28.5 | 29.0 | 29.5 | 30.0 | 30.5 | 31.0 | 31.5 | 32.0 |
|--|----------|--------|--------|--------|--------|--------|--------|--------|
| Vibration Amp. at Flywheel Bearings-g's | Inboard | - | - | - | - | - | - | - |
| | Outboard | - | - | - | - | - | - | - |
| (1) Flywheel Speed at Full Motoring-RPM | 52,000 | 52,000 | 52,000 | 52,000 | 52,000 | 52,000 | 52,000 | 52,000 |
| (2) Minimum Speed Attain Under Load-RPM | | | | | | | | |
| Total Precessional Load Cycles | 12320 | 12550 | 12800 | 13050 | 13300 | 13560 | 13800 | 14060 |
| Ave. Tilt Table Velocity - deg/sec. | 13.9 | 13.8 | 13.7 | 14.3 | 14.2 | 14.1 | 14.0 | 14.1 |
| Ave. Load on Flywheel Bearings - lbs. | 59 | 58 | 57 | 61 | 60 | 60 | 61 | 60 |
| NO. TEMPERATURE DATA - DEG. F | | | | | | | | |
| 1 Test Pump Inlet | 129 | 130 | 130 | 127 | 127 | 128 | 128 | 128 |
| 2 Test Pump Return | 129 | 131 | 132 | 128 | 127 | 129 | 129 | 129 |
| 3 Test Pump Case Drain | 198 | 198 | 200 | 198 | 197 | 198 | 200 | 198 |
| 4 Main Hyd. Reservoir Supply | 118 | 118 | 117 | 118 | 118 | 118 | 116 | 117 |
| 5 Lube Oil Return | 222 | 217 | 216 | 218 | 212 | 212 | 210 | 209 |
| 6 Lube Oil Suction | 90 | 83** | 75 | 65 | 60 | 58 | 58 | 54 |
| 7 Scavenge Oil Return | 134 | 131 | 130 | 127 | 128 | 128 | 129 | 129 |
| 8 Gear Box Bearing Adjacent Pump | 215 | 211 | 210 | 210 | 207 | 205 | 208 | 205 |
| 9 Gear Box Bearing Adjacent Flywheel | 186 | 188 | 185 | 182 | 183 | 181 | 180 | 180 |
| 10 Inboard Flywheel Bearing | 218 | 210 | 210 | 210 | 208 | 206 | 209 | 209 |
| 11 Outboard Flywheel Bearing | 213 | 209 | 207 | 206 | 205 | 202 | 201 | 201 |
| 12 Flywheel Case Housing | 180 | 178 | 176 | 173 | 170 | 172 | 170 | 170 |
| NO. SYSTEM PRESSURE DATA - PSII | | | | | | | | |
| 13 Outboard Flywheel Bearing | 26 | 26 | 26 | 26 | 28 | 28 | 28 | 28 |
| 14 Inboard Flywheel Bearing | 27 | 27 | 27 | 27 | 29 | 28 | 29 | 28 |
| 15 Lube Pump Pressure Port | 59 | 59 | 59 | 59 | 59 | 59 | 60 | 60 |
| 16 Lube Reservoir | 0 | 0 | 0 | 0 | 0 | 0 | 0 | 0 |
| 17 Hyd. Supply Pump Press. Port | 1990 | 1990 | 1990 | 1990 | 1990 | 1990 | 1990 | 1990 |
| 18 Test Motor Press. Port | 1990 | 1990 | 1990 | 1990 | 1990 | 1990 | 1990 | 1990 |
| 19 Test Motor Return Port | 120 | 115 | 115 | 120 | 120 | 120 | 120 | 120 |
| 20 Test Motor Case Drain | 2 | 2 | 2 | 2 | 2 | 2 | 2 | 2 |
| 21 Vacuum at Flywheel Hub - in. Hg | 28.9 | 28.9 | 28.9 | 29.0 | 28.9 | 29.0 | 29.0 | 29.0 |
| 22 Vacuum (Hub to Tip AP) Across Flywheel Housing - in. Hg | 0.5 | 0.5 | 0.5 | 0.5 | 0.4 | 0.4 | 0.4 | 0.4 |
| 23 Pressure at Flywheel Hub - cm Hg Ab | 2.7 | 2.7 | 2.7 | 2.7 | 2.7 | 2.6 | 2.5 | 2.6 |
| NO. FLUID FLOW DATA - GPM | | | | | | | | |
| 24 Inlet Flow to Motor | 23 | 23 | 23 | 23 | 23 | 23 | 23 | 23 |
| 25 Case Drain Flow of Motor | .2 | .2 | .2 | .2 | .2 | .2 | .2 | .2 |
| 26 Outboard Bearing Lube Flow cc/min | 405 | 405 | 405 | 405 | 420 | 420 | 420 | 420 |
| 27 Inboard Bearing Lube Flow cc/min | 415 | 415 | 415 | 415 | 430 | 420 | 430 | 420 |

**started to cool lube reservoir with liquid CO₂

Table VII (Concluded)

TILT TABLE SIMULATOR TEST DATA

Summary Data Sheet No. 9

Date: 3-2-67

| | | | | | | | | | |
|---|--|--------|--------|--------|--------|------------|----------------------|--|--|
| Running Time of Test - Hours | | 32.5 | 33.0 | 33.5 | *34.0 | 34.5 | | | |
| Vibration Amp. at Flywheel Bearings-g's | Inboard | - | - | 4.2 | 4.5 | 4.5 | | | |
| | Outboard | - | - | 6.6 | 6.5 | 9.5 | | | |
| (1) Flywheel Speed at Full Motoring-RPM | | 52,000 | 52,000 | 52,000 | 53,000 | 53,000 | | | |
| (2) Minimum Speed Attain Under Load-RPM | | | | | | | | | |
| Total Precessional Load Cycles | | 14300 | 14560 | 14780 | 15080 | 15280 | | | |
| Ave. Tilt Table Velocity - deg/sec. | | 14.1 | 14.2 | 14.0 | 14.0 | 14.0 | | | |
| Ave. Load on Flywheel Bearings - lbs. | | 60 | 62 | 64 | 64 | - | (Failure of bearing) | | |
| NO. TEMPERATURE DATA - DEG. F | | | | | | | | | |
| 1 | Test Pump Inlet | 128 | 128 | 125 | 132 | 138 | | | |
| 2 | Test Pump Return | 129 | 129 | 128 | 137 | 140 | | | |
| 3 | Test Pump Case Drain | 197 | 197 | 195 | 206 | 218 | | | |
| 4 | Main Hyd. Reservoir Supply | 118 | 118 | 118 | 126 | 142 | | | |
| 5 | Lube Oil Return | 207 | 220 | 218 | 220 | 295 | | | |
| 6 | Lube Oil Suction | 52 | 55 | 60 | 73 | 78 | | | |
| 7 | Scavange Oil Return | 123 | 131 | 128 | 126 | 118 | | | |
| 8 | Gear Box Bearing Adjacent Pump | 202 | 208 | 203 | 197 | 206 | | | |
| 9 | Gear Box Bearing Adjacent Flywheel | 181 | 181 | 183 | 178 | 184 | | | |
| 10 | Inboard Flywheel Bearing | 201 | 212 | 206 | 200 | 218 | | | |
| 11 | Outboard Flywheel Bearing | 200 | 210 | 206 | 208 | 296 | | | |
| 12 | Flywheel Case Housing | 169 | 171 | 170 | 146 | 225 to 310 | | | |
| NO. SYSTEM PRESSURE DATA - PSIG | | | | | | | | | |
| 13 | Outboard Flywheel Bearing | 28 | 31 | 27 | 32 | 23 | | | |
| 14 | Inboard Flywheel Bearing | 28 | 29 | 28 | 33 | 24 | | | |
| 15 | Lube Pump Pressure Port | 60 | 60 | 60 | 70 | 70 | | | |
| 16 | Lube Reservoir | 0 | 0 | 0 | 0 | 0 | | | |
| 17 | Hyd. Supply Pump Press. Port | 1990 | 1990 | 1990 | 2860 | 2860 | | | |
| 18 | Test Motor Press. Port | 1990 | 1990 | 1990 | 2860 | 2860 | | | |
| 19 | Test Motor Return Port | 120 | 120 | 120 | 125 | 125 | | | |
| 20 | Test Motor Case Drain | 2 | 2 | 2 | 2 | 2 | | | |
| 21 | Vacuum at Flywheel Hub - in. Hg | 29.1 | 29.1 | 29.1 | 29.5 | 29.5 | | | |
| 22 | (Hub to Tip ΔP) Vacuum Across Flywheel Housing - in. Hg | 0.4 | 0.3 | 0.4 | 0.6 | 0.6 | | | |
| 23 | Press. at Flywheel Hub - cm. Hg Ab | 2.4 | 2.4 | 2.4 | 1.3 | 1.3 | | | |
| NO. FLUID FLOW DATA - GPM | | | | | | | | | |
| 24 | Inlet Flow to Motor | 23 | 23 | 23 | 23.6 | 23.6 | | | |
| 25 | Case Drain Flow of Motor | 0.2 | 0.2 | 0.2 | 0.2 | 0.2 | | | |
| 26 | Inboard Bearing Lube Flow cc/min | 420 | 430 | 410 | 460 | 375 | | | |
| 27 | Outboard Bearing Lube Flow cc/min | 420 | 430 | 420 | 470 | 385 | | | |

*Start new days testing.

Table VIII
TILT TABLE TEST RESULTS SUMMARY

| | |
|--|-------------------------------|
| a. Flywheel, shaft moment of inertia | .266 in.-lb sec ² |
| b. Flywheel, gearbox, motor moment of inertia | .268 in.-lb sec ² |
| c. Upper flywheel speed | 5,250 rad/sec |
| d. Lower flywheel speed | 4,660 rad/sec |
| e. Average hydraulic motor speed | 7,220 rpm |
| f. Kinetic energy at upper speed | 3.83 x 10 ⁶ in.-lb |
| g. Kinetic energy at lower speed | 2.91 x 10 ⁶ in.-lb |
| h. Kinetic energy increase during motoring | 0.92 x 10 ⁶ in.-lb |
| i. Time required to increase speed from lower speed to upper speed | 10.0 sec |
| j. Average power to accelerate | 13.9 HP |
| k. Angular acceleration of flywheel | 59 rad/sec ² |
| m. Torque at flywheel drive quill due to acceleration | 15.72 in.-lb |
| n. Hydraulic pressure drop across motor ports | 1,890 lb/in. ² |
| o. Displacement of hydraulic motor | .646 in. ³ /rev |
| p. Total power supplied to hydraulic motor due to displacement at average speed | 22.2 HP |
| q. Hydraulic motor shaft power at an assumed efficiency of 85 percent [(p) x .85] | 18.9 HP |
| r. Average gearbox and flywheel windage losses plus scavenge, lube pump and vacuum pump power extraction (q - j) | 5.0 HP |

TILT TABLE SIMULATOR TEST DATA RECORD

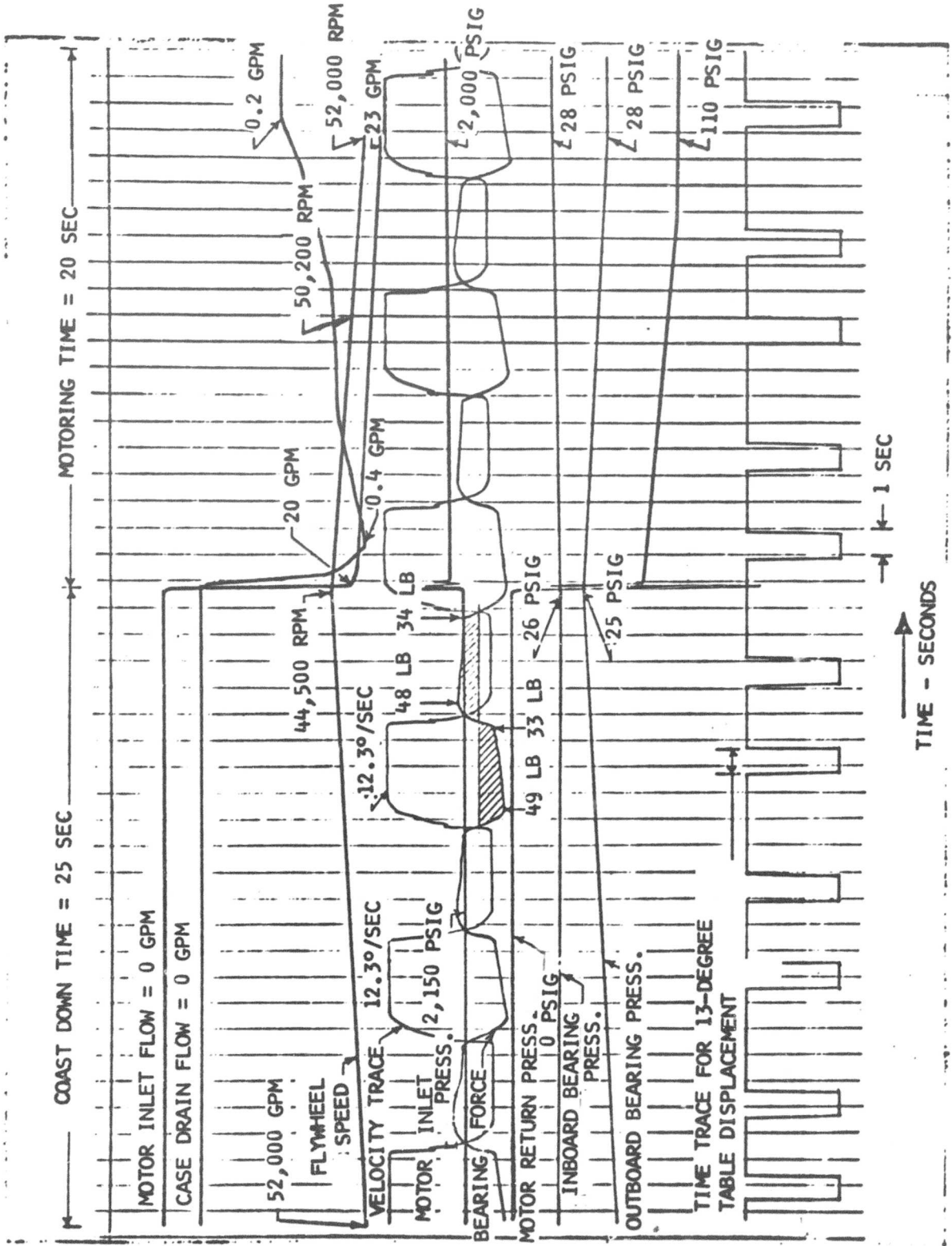

Figure 25. Tilt Table Test Oscilloscope Record

Upon starting up for the next day's operation it was noticed that each time the flywheel tilted downward there was an audible screech. This was shortly followed by a runaway temperature rise on the outboard bearing and the test was shut down at 34.5 hours. Disassembly of the flywheel revealed that the outboard bearing (side farthest from the gearbox) had failed. The ball separator had completely disintegrated and had been carried away in the oil flow in the form of chips. The inner race was badly mutilated; however, all balls had remained in place. The outer race and balls had numerous cuts, scratches, and nicks but discoloration had not progressed to any great extent. The inner race was badly discolored and had, in fact, undergone plastic flow under the rolling load of the balls. No other parts of the flywheel had received any appreciable damage, except the oil slinger blades, which had been dented and bent by the pieces of the bearing separator which had passed through them. The disassembled flywheel is shown in figure 5.

The gearbox was returned to the supplier for teardown and inspection. All internal parts were deemed to be in good condition and reassembly did not require the replacement of any vital details.

Visual inspection of the surface of the flywheel revealed that carbon from the seals had discolored it somewhat all over; also, discoloration at the tip had occurred as a result of the combination of temperature plus the carbon and oil. The maximum temperature estimated at the tip from this discoloration was 400° F.

A basic objective of Tilt Table Testing was to determine as accurately as possible the actual flywheel losses as one of the major indices of performance. The following discussion outlines the method used to approximate the actual losses. In table VIII the summarized listing is based on the speed-up portion of the energy storage substation cycle. Two end conditions, i.e., conditions during lower flywheel speed and upper flywheel speed, can be satisfactorily defined from the measured data. Likewise, this speed-up time is established with fair accuracy.

Considering the complexity associated with demonstrated power extraction capability (in this case, indirectly measured by power input to the flywheel from the motor), it is impractical to treat the problem with other than average values. This stems from the fact that there are many variables introduced for which instantaneous values were not taken as data, and/or for which suitable empirical mathematical expressions are not available. Examples are: aerodynamic losses of the flywheel; windage losses in the gearbox; lube, scavenge, and vacuum pump power requirements; and pressure differential across the motor ports.

It is for these reasons that total energy was divided by total time to give average power. Average power was used to determine angular acceleration and shaft torque.

Power from the motor was then determined using 85 percent overall efficiency. This value is estimated and no attempt was made to establish it from previous engineering data on the motor, principally because this application uses a different hydraulic fluid (MIL-O-5606) from that which was used during its development (Oronite 8200).

Item r, table VIII (average gearbox and flywheel windage losses plus scavenge, lube, and vacuum pump power extraction) is, however, in the range of magnitude expected. A further breakdown of this loss can only be estimated. The flywheel had a differential pressure across it due to its own vacuum pumping effect. This does not lend itself readily to the power loss calculations shown in figure 3. Also, these losses are a function of speed to the 2-4/5 power. Taking these factors into account, it is believed that the flywheel losses of item r, table VIII, are less than 50 percent of the 5 horsepower.

Activity which followed on this simulator consisted of checkout of motor-pumps and flywheel-gearbox combinations. The flywheel-gearbox combinations are designated in order of their manufacture as energy storage substations No. 1, No. 2, and No. 3. The No. 1 energy storage substation was used in the above-mentioned endurance test.

When checkout runs of energy storage substation No. 2 were made, they proved to be not completely satisfactory in that higher bearing temperatures (220° to 235° F), and poorer flywheel housing vacuum were encountered, when compared to that experienced with the No. 1 energy storage substation.

The high bearing temperatures were believed to have resulted from one or both of two factors. The first is associated with a new seal which was installed on the hydraulic motor (XB-70 emergency generator motor). It had an improperly installed static seal which caused overheating, allowing heat to be conducted through the gearbox housing to the gearbox bearings. The second factor was the poorer performance of the flywheel vacuum system, which caused more than a normal amount of heat in the flywheel housing to be conducted to the flywheel bearings. The poorer vacuum was the result of the leaking flywheel shaft seal, and a leaking seal at the gearbox pump group housing. Upon replacement of these defective seals, the equipment operated with bearing temperatures around 170° F which were somewhat lower than those exhibited by the first assembly.

In the meantime, No. 1 energy storage substation had been rebuilt and was ready for checkout and continuation of the endurance test on the tilt table. However, checkout of this reassembled unit revealed higher bearing temperatures than it had exhibited upon initial assembly. It was believed that the possible cause was misalignment of the bearings which support the flywheel. For this reason, the flywheel assembly was disassembled and dimensionally checked. Alignment was found to be satisfactory; however, the lube jet ring O-rings were found to be "nibbled" and pieces of rubber were plugging the lubrication jets.

Since the disassembly and dimensional checks on this first assembly was known to be a time-consuming operation, it was decided to continue the tilt table endurance test using the No. 2 energy storage substation. This testing was scheduled to start with tilt rates equivalent to those called for by Test Objective II in table VI. The time scheduled for this tilt rate was 2.06 hours as an accelerated equivalent of Test Objective I and .45 hour for Test Objective II, plus an additional 2.05 hours to accomplish Test Objective III.

Investigation of the initial flywheel bearing failure led to a conclusion that it was premature and was probably the direct result of insufficient preload. A preload of 80 pounds had been intended; however, an inspection and measurement of detail parts disclosed that it was 69 pounds. Upon refurbishing the flywheel, the spring load was increased to 150 pounds.

Because this change was made, it was believed desirable to use the accelerated equivalent for Test Objective I. It was thought that the unit would quite easily pass through this segment of the test, and permit going on to segments of the test involving higher loads and their associated problems.

This test lasted for only 1 hour and 10 minutes. At this time the in-board bearing on the flywheel failed due to structural failure of the aluminum bronze ball separator. Inspection of the failed parts revealed that there was no evidence of overtemperature associated with this failure. It is believed that a short, sharp physical overload or series of overloads occurred on this separator and caused the failure. Although the exact nature of the mechanics of the overload application internal to the bearing is not known, it is quite clear that it resulted from the precessional loads associated with the high tilt rates.

It was also noted in connection with the higher tilt rates that the flywheel bearings would show a steady, slow temperature rise to unacceptable levels (230° F) until tilt table operation was interrupted. Upon cessation of tilting, the bearings would cool by 10° to 15° F to a lower stabilized operating temperature. In recognition of the fact that aircraft do not barrel roll through the sky for hours on end, it was decided to periodically interrupt the tilt-table operation to more closely simulate actual air vehicle operation. However, possibly because of the damage already done to the bearing before this approach was adopted, the time to cool down became progressively longer and the time to heat up became progressively shorter until the previously described failure occurred.

The data from this test are shown in table IX (two pages). The pickup points for these data may be determined by comparing the data numbers from table IX with those on the system schematic figure 15.

The Tilt Table Simulator was next used to check out the operation of the No. 3 energy storage substation. This unit displayed bearing temperatures around 202° F when operated by the Vickers hydraulic motor (XB-70 emergency generator motor). While this checkout was in progress the first of the New York Airbrake motor-pumps with automatic pressure sensing was received. This unit was checked out on the same (No. 3) energy storage substation and a bearing stabilization temperature of 215° F was noted.

It is believed that the difference in stabilized bearing temperatures between the two hydraulic motors stems from the magnitude of the vibration introduced by the stroking of the pistons. The magnitude of the vibration, in turn, is a function of the operating pressure. In the case of the emergency generator motor a lower hydraulic pressure (2,000 versus 3,000 psi) is used resulting in lower piston stroke vibrational accelerations for that motor (3.5G versus 7G).

Table IX

TILT TABLE SIMULATOR TEST DATA
(SUBSTATION NO. 2)

Summary Data Sheet No. 1

Date: 4-5-67

| Running Time of Test - Hours | Running Time | 0.25 | 0.50 | 1.00 | 1.5 | 1.93 | 2.25 | 2.42 | 2.92 |
|---|--|--------|--------|--------|--------|--------|--------|--------|--------|
| Vibration Amp. at Flywheel Bearings-g's | Inboard | 3.0 | 3.0 | 4.2 | 3.4 | 4.2 | 3.5 | 4.1 | 4.1 |
| | Outboard | 3.0 | 3.0 | 4.2 | 3.4 | 4.2 | 3.6 | 4.0 | 4.1 |
| (1) Flywheel Speed at Full Motoring-RPM | | 52,400 | 52,400 | 52,400 | 52,400 | 52,400 | 52,400 | 52,400 | 52,400 |
| (2) Minimum Speed Attain Under Load-RPM | | -- | -- | -- | -- | -- | -- | -- | -- |
| Total Precessional Load Cycles | | -- | -- | 465 | -- | 750 | -- | 974 | 1096 |
| Ave. Tilt Table Velocity - deg/sec. | | -- | -- | 30 | -- | 30 | -- | 30 | 35 |
| Ave. Load on Flywheel Bearings - lbs. | | -- | -- | 132 | -- | 131 | -- | 132 | 145 |
| NO TEMPERATURE DATA - DEG. F | | | | | | | | | |
| 1 | Test Pump Inlet | 112 | 125 | 127 | 130 | 125 | 131 | 127 | 128 |
| 2 | Test Pump Return | 118 | 130 | 130 | 135 | 130 | 135 | 132 | 132 |
| 3 | Test Pump Case Drain | 192 | 200 | 200 | 200 | 200 | 202 | 204 | 198 |
| 4 | Main Hyd. Reservoir Supply | 105 | 115 | 120 | 122 | 122 | 122 | 120 | 123 |
| 5 | Lube Oil Return | 136 | 150 | 230 | 186 | 225 | 188 | 220 | 219 |
| 6 | Lube Oil Suction | 75 | 75 | 75 | 80 | 78 | 82 | 87 | 82 |
| 7 | Scavange Oil Return | 112 | 120 | 150 | 140 | 148 | 140 | 154 | 150 |
| 8 | Gear Box Bearing Adjacent Pump | 168 | 178 | 220 | 198 | 225 | 200 | 226 | 228 |
| 9 | Gear Box Bearing Adjacent Flywheel | 166 | 170 | 192 | 182 | 195 | 185 | 195 | 198 |
| 10 | Inboard Flywheel Bearing | 135 | 150 | 220 | 182 | 230 | 188 | 220 | 235 |
| 11 | Outboard Flywheel Bearing | 135 | 150 | 224 | 182 | 225 | 188 | 218 | 212 |
| 12 | Flywheel Case Housing | 115 | 137 | 200 | 170 | 195 | 168 | 190 | 185 |
| NO SYSTEM PRESSURE DATA - PSIG | | | | | | | | | |
| 13 | Outboard Flywheel Bearing | 26 | 26 | 35 | 36 | 35 | 35 | 35 | 40 |
| 14 | Inboard Flywheel Bearing | 26 | 26 | 36 | 37 | 36 | 36 | 36 | 42 |
| 15 | Lube Pump Pressure Port | 57 | 55 | 50 | 52 | 50 | 50 | 50 | 50 |
| 16 | Lube Reservoir | 0 | 0 | 0 | 0 | 0 | 0 | 0 | 0 |
| 17 | Hyd. Supply Pump Press. Port | 2480 | 2480 | 2450 | 2450 | 2450 | 2450 | 2450 | 2450 |
| 18 | Test Motor Press. Port | 2340 | 2340 | 2340 | 2340 | 2340 | 2340 | 2340 | 2340 |
| 19 | Test Motor Return Port | 110 | 110 | 110 | 110 | 110 | 110 | 110 | 110 |
| 20 | Test Motor Case Drain | 4 | 4 | 4 | 4 | 4 | 4 | 4 | 4 |
| 21 | Vacuum at Flywheel Hub - in. Hg | 29.4 | 29.35 | 29.2 | 29.2 | 29.1 | 29.2 | 29.2 | 29.2 |
| 22 | (HUB TO TIP ΔP) Vacuum Across Flywheel Housing - in. Hg | 0.7 | 0.7 | 0.9 | 0.9 | 1.0 | 1.0 | 1.0 | 1.1 |
| 23 | Pressure at Flywheel Hub - CM Hg Ab | 2.5 | 2.6 | 3.5 | 3.1 | 3.6 | 2.9 | 3.0 | 3.1 |
| NO FLUID FLOW DATA - GPM | | | | | | | | | |
| 24 | Inlet Flow to Motor | 23 | 23 | 23 | 23 | 23 | 23 | 23 | 23 |
| 25 | Case Drain Flow to Motor | 0.2 | 0.2 | 0.25 | 0.25 | 0.25 | 0.25 | 0.25 | 0.25 |
| 26 | Outboard Bearing Lube Flow cc/min. | 410 | 410 | 500 | 500 | 500 | 500 | 500 | 585 |
| 27 | Inboard Bearing Lube Flow cc/min. | 400 | 400 | 500 | 500 | 500 | 500 | 500 | 595 |

*Stopped precessional load cycling during this period to allow bearing temperatures to decrease.

Table IX (Concluded)

TILT TABLE SIMULATOR TEST DATA
(SUBSTATION NO. 2)Summary Data Sheet No. 2Date: 4-5-67

| | | | | | | | | | |
|---|--|--------|--|--|--|--|--|--|---------------------------|
| Running Time of Test - Hours | Running | 3.22 | | | | | | | |
| | Tilting | 1.17 | | | | | | | |
| Vibration Amp. at Flywheel Bearings-g's | Inboard | 4.5 | | | | | | | |
| | Outboard | 4.2 | | | | | | | |
| (1) Flywheel Speed at Full Motoring-RPM | | 52,400 | | | | | | | |
| (2) Minimum Speed Attain Under Load-RPM | | - | | | | | | | |
| Total Precessional Load Cycles | | 1124 | | | | | | | |
| Ave. Tilt Table Velocity - deg/sec. | | 35 | | | | | | | |
| Ave. Load on Flywheel Bearings - lbs. | | 147 | | | | | | | |
| NO TEMPERATURE DATA - DEG. F | | | | | | | | | |
| 1 | Test Pump Inlet | 130 | | | | | | | |
| 2 | Test Pump Return | 135 | | | | | | | |
| 3 | Test Pump Case Drain | 198 | | | | | | | |
| 4 | Main Hyd. Reservoir Supply | 125 | | | | | | | |
| 5 | Lube Oil Return | 204 | | | | | | | |
| 6 | Lube Oil Suction | 83 | | | | | | | |
| 7 | Scavange Oil Return | 145 | | | | | | | |
| 8 | Gear Box Bearing Adjacent Pump | 227 | | | | | | | |
| 9 | Gear Box Bearing Adjacent Flywheel | 190 | | | | | | | |
| 10 | Inboard Flywheel Bearing | 250 | | | | | | | ← Inboard bearing failed. |
| 11 | Outboard Flywheel Bearing | 205 | | | | | | | |
| 12 | Flywheel Case Housing | 175 | | | | | | | |
| NO SYSTEM PRESSURE DATA - PSIG | | | | | | | | | |
| 13 | Outboard Flywheel Bearing | 32 | | | | | | | |
| 14 | Inboard Flywheel Bearing | 32 | | | | | | | |
| 15 | Lube Pump Pressure Port | 50 | | | | | | | |
| 16 | Lube Reservoir | 0 | | | | | | | |
| 17 | Hyd. Supply Pump Press. Port | 2480 | | | | | | | |
| 18 | Test Motor Press. Port | 2340 | | | | | | | |
| 19 | Test Motor Return Port | 110 | | | | | | | |
| 20 | Test Motor Case Drain | 4 | | | | | | | |
| 21 | Vacuum at Flywheel Hub - in. Hg | 29.2 | | | | | | | |
| 22 | (HUB TO TIP A.P.) Vacuum Across Flywheel Housing - in. Hg | 1.1 | | | | | | | |
| 23 | Pressure at Flywheel Hub - CM Hg Ab | 3.1 | | | | | | | |
| NO FLUID FLOW DATA - GPM | | | | | | | | | |
| 24 | Inlet Flow to Motor | 23 | | | | | | | |
| 25 | Case Drain Flow to Motor | 0.25 | | | | | | | |
| 26 | Outboard Bearing Lube Flow cc/min. | 455 | | | | | | | |
| 27 | Inboard Bearing Lube Flow cc/min. | 455 | | | | | | | |

During these checkout operations of the motor-pump it was discovered that bronze particles were being generated and discharged from the case drain line. Operation of the motor-pump was immediately discontinued and it was returned to the supplier for inspection and refurbishment. A review of the test data records revealed that the return port was not being pressurized to a level as high as would be recommended by New York Airbrake. During portions of the motoring and pumping cycle the pressure would drop as low as 60 psi. (A minimum of 70 psi is recommended by the supplier.) While the motor-pump was being refurbished, the No. 3 energy storage substation was removed from the Tilt Table and installed on the Intermittent Duty Cycle Simulator.

After refurbishment the motor-pump unit was redelivered and it checked out satisfactorily on the Tilt Table Simulator using energy storage substation No. 1. The flow and pressure settings were adjusted to proper calibration. It was then installed on the Intermittent Duty Cycle Simulator.

The Tilt Table Simulator was next used to check out the No. 2 energy storage substation following its refurbishment due to the second endurance test failure. After a short period of operation, it was suspected from the temperature readings that leakage into the evacuated portion of the flywheel was occurring. To verify this, an external vacuum pump was attached to the drain line at the bottom of the flywheel housing. In approximately 2 minutes a fluid quantity approaching a quart was withdrawn while the flywheel was maintaining 52,000 rpm.

It is significant to observe that this excessive oil leakage into the flywheel cavity did not create dangerous temperature conditions (evacuated oil reached 270° F) or create destructive drag forces.

Later disassembly of the flywheel disclosed that improperly sized static O-ring seals had inadvertently been installed where the carbon face seal cartridge is sealed to the flywheel housing.

The precessional load endurance test was next attempted using the energy storage substation No. 1 and the Vickers emergency generator motor. Upon checkout of this test arrangement, an inadvertent closing off of the case drain line led to failure of the rotating group.

The test was resumed using the prototype New York Airbrake motor-pump, i.e., the one using manual control to effect motoring and pumping modes. Approximately 4-1/2 hours of test time was completed using a tilt table precessional rate of 11.7 degrees/second (54-pound bearing load) before the test was terminated due to impending failure of the motor-pump. This was indicated by the fact that a large amount of metal chips were being produced and discharged through the case return port. The data from this test are shown in table X (one page). Figure 26 is a sample data record from which some of the data were taken, and which were used to monitor performance.

Following termination of the third precessional load endurance test, the final two New York Airbrake motor-pumps with automatic pressure-sensing control were received. These units were checked out and calibrated with respect to pressure and flow (speed) on the tilt table. After checkout, one unit was installed on the Intermittent Duty Cycle Simulator as a replacement for the

Table X

TILT TABLE SIMULATOR TEST DATA
(SUBSTATION NO. 1)

| SUMMARY DATA SHEET NO. 1 | | DATE: 5-22-67 | | | | | | | | |
|---|---|---------------|--------------|--------------|--------------|--------------|--------------|--------------|--------------|-----|
| Running Time of Test - Hours | | 0.5 | 1.0 | 1.5 | 2.0 | 2.5 | 3.0 | 3.5 | 4.0 | |
| Vibration Amp. at Flywheel | | Inboard | * | * | 6.5 | 7.3 | 8.5 | 8.5 | 7.5 | 7.5 |
| Bearings - g's | | Outboard | 6.5 | 8.0 | 6.5 | 9.0 | 9.7 | 9.7 | 9.7 | 9.1 |
| (1) Flywheel Speed at Full Motoring-RPM | | 52,000 | 52,000 | 52,000 | 52,000 | 52,000 | 52,000 | 52,000 | 52,000 | |
| (2) Minimum Speed Attain Under Load-RPM | | 38,000 | 38,000 | 38,000 | 38,000 | 38,000 | 38,000 | 38,000 | 38,000 | |
| Total Precessional Load Cycles | | 84 | 210 | 334 | 562 | 880 | 1150 | 1410 | 1690 | |
| Ave. Tilt Table Velocity - deg/sec. | | 11.7 | 11.7 | 11.7 | 11.7 | 11.7 | 11.7 | 11.7 | 11.7 | |
| Ave. Load on Flywheel Bearings - lbs. | | -- | 49-57 | 51-52 | 48-59 | 49-58 | 47-56 | 48-59 | 49-59 | |
| NO. TEMPERATURE DATA - DEG. F | | | | | | | | | | |
| 1 | Test Pump Inlet | 110 | 125 | 130 | 135 | 134 | 126 | 130 | 135 | |
| 2 | Test Pump Return | 125 | 128 | 128 | 119 | 125 | 125 | 127 | 130 | |
| 3 | Test Pump Case Drain | 178 | 178 | 178 | 166 | 170 | 172 | 175 | 172 | |
| 4 | Main Hyd. Reservoir Supply | 123 | 125 | 126 | 115 | 122 | 124 | 125 | 127 | |
| 5 | Lube Oil Return | 210 | 215 | 214 | 195 | 205 | 210 | 207 | 210 | |
| 6 | Lube Oil Suction | 78 | 80 | 81 | 75 | 80 | 83 | 85 | 87 | |
| 7 | Scavange Oil Return | 160 | 160 | 162 | 150 | 150 | 155 | 155 | 155 | |
| 8 | Gear Box Bearing Adjacent Pump | 200 | 192 | 194 | 180 | 185 | 190 | 188 | 190 | |
| 9 | Gear Box Bearing Adjacent Flywheel | 210 | 202 | 204 | 185 | 195 | 195 | 196 | 197 | |
| 10 | Inboard Flywheel Bearing | 200 | 202 | 205 | 184 | 195 | 195 | 196 | 197 | |
| 11 | Outboard Flywheel Bearing | 198 | 202 | 205 | 185 | 195 | 195 | 196 | 197 | |
| 12 | Flywheel Case Housing | 162 | 165 | 170 | 147 | 165 | 170 | 160 | 160 | |
| NO. SYSTEM PRESSURE DATA - PSIG | | | | | | | | | | |
| 13 | Outboard Flywheel Bearing | 32 | 30 | 30 | 30 | 30 | 30 | 30 | 30 | |
| 14 | Inboard Flywheel Bearing | 34 | 31 | 31 | 31 | 31 | 31 | 31 | 31 | |
| 15 | Lube Pump Pressure Port | 50 | 50 | 50 | 51 | 50 | 50 | 50 | 50 | |
| 16 | Lube Reservoir | 0 | 0 | 0 | 0 | 0 | 0 | 0 | 0 | |
| 17 | Hyd. Supply Pump Press. Port | 3360 | 3360 | 3360 | 3360 | 3275 | 3275 | 3275 | 3275 | |
| 18 | Test Motor Press. Port (Motoring) | 3340 | 3340 | 3340 | 3340 | 3200 | 3200 | 3250 | 3250 | |
| 19 | Test Motor Return Port (Motoring) | 120 | 120 | 120 | 120 | 120 | 120 | 120 | 120 | |
| 20 | Test Pump Press. Range (Pumping) | 2350 2300 | 2350 2300 | 2350 2300 | 2350 2300 | 2350 2300 | 2350 2300 | 2350 2300 | 2350 2300 | |
| 21 | Test Pump Suction Press. (Pumping) | 125 | 125 | 125 | 125 | 125 | 125 | 125 | 125 | |
| 22 | Test Motor - Pump Case Drain | 4 | 4 | 4 | 4 | 4 | 4 | 4 | 4 | |
| 23 | Vacuum at Flywheel Hub - in. Hg. | 29.5 | 29.4 | 29.4 | 29.2 | 29.0 | 29.0 | 29.0 | 29.0 | |
| 24 | (HUB TO TIP AP) Vacuum Across Flywheel Housing-in. Hg. | 0.75 | 0.75 | 0.75 | - | - | - | - | - | |
| 25 | Pressure at Flywheel Hub - CM Hg Ab. | 1.7 | 1.7 | 1.7 | 2.0 | 2.6 | 2.6 | 2.6 | 2.6 | |
| NO. FLUID FLOW DATA - GPM | | | | | | | | | | |
| 26 | Inlet Flow to Motor | 13.5 | 13.5 | 15.3 | 15.0 | 15.2 | 15.1 | 15.1 | 15.1 | |
| 27 | Motor-Pump Case Drain Flow | .5-.7 | .5-.7 | .5-.7 | .5-.7 | .5-.7 | .5-.7 | .5-.7 | .5-.7 | |
| 28 | A.P.U. Flow Rate | 18.5 | 18.5 | 18.5 | 18.5 | 18.5 | 18.5 | 18.5 | 18.5 | |
| 29 | Combined A.P.U. & Test Pump Flow | 32.0 30.0 | 32.0 30.0 | 32.0 29.2 | 31.6 29.2 | 31.6 29.2 | 31.6 29.2 | 31.6 29.2 | 31.6 29.2 | |
| 30 | Test Pump Flow Rate | 13.5 11.5 | 13.5 11.3 | 13.5 10.7 | 13.5 10.7 | 13.5 10.7 | 13.5 10.7 | 13.5 10.7 | 13.5 10.7 | |
| 31 | Outboard Bearing Lube Flow - cc/min. | 775 | 730 | 730 | 730 | 730 | 730 | 730 | 730 | |
| 32 | Inboard Bearing Lube Flow - cc/min. | 800 | 760 | 760 | 760 | 760 | 760 | 760 | 760 | |

*Bad data, replaced transducer.

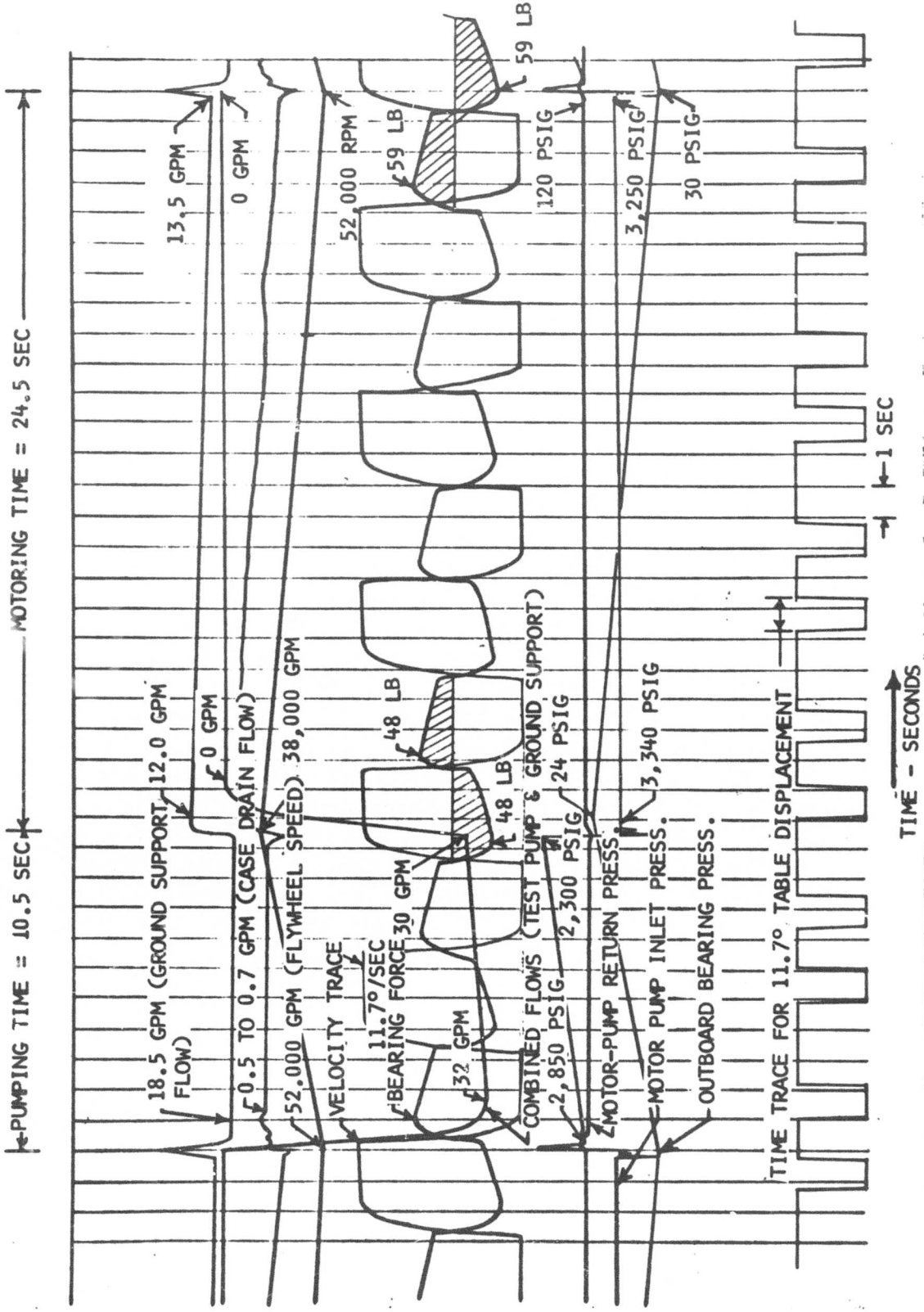

Figure 26. Tilt Table Test Oscillograph Record

first (automatic motor-pump) delivered unit which failed and was returned to the supplier for refurbishment. The other motor-pump was retained at the tilt table for use in the Continuous Duty Cycle Simulator. Tilt Table Simulator testing was discontinued at this point. The Continuous Duty Cycle Simulator was planned to utilize portions of the Tilt Table Simulator. The schedule requirements associated with its fabrication did not permit further exploring of the bearing problems as a Tilt Table.

Prior to operation of the simulator, an analysis of the possible resonant conditions of vibration was made on an IBM 7094 computer using a cathode ray tube graph-plotting camera for output results, as well as numerical printout. The FORTRAN program which was employed took all factors except one into careful consideration. The physical factors such as size, shape, inertia, bearing spring rates, etc, were quite adequately estimated. However, damping could not be adequately estimated and was neglected in the computation. Figure 27 is a schematic of the spring system used as a basis for the computer program.

The computer analysis predicted serious problems as indicated in table XI. However, as stated in the foregoing test description, the vibration search ". . . revealed no resonance conditions of measurable magnitude that could be positively identified. . ."

Configuration "A" in table XI was intended to most closely represent the configuration as tested on the Tilt Table. It should be noted that K_2 , K_3 , etc, are the rates for the springs indicated on the system schematic of figure 27. Configurations "B" through "G" are other spring system arrangements which were investigated in case actual testing indicated a change in design was in order.

D. TILT TABLE SIMULATOR TEST CONCLUSIONS

As a result of the Tilt Table Simulator testing, a high confidence level can be placed on the feasibility of successfully designing energy storage flywheels for airborne applications. The amount of precessional loading endured by the test article would qualify it for installation, with selective position orientation, in aircraft with pitching characteristics similar to heavy long-range bombers and supersonic transports for periods in excess of 3,000 flight hours. The test results would also indicate that this unit, as tested, could be selectively orientated in fighter reconnaissance and low-level strategic-type aircraft and operated without servicing for periods up to 1,000 hours. In each of these cases "selective orientation" means mounting with flywheel axis parallel to the fuselage centerline such that the flywheel bearings would not feel "roll" induced precessional loads.

There are many improvements which can be made to the bearing design, and it would, on this basis, be possible to lengthen the time between replacements and/or increase the flexibility of position orientation.

The failures experienced indicate that the bearing ball fit-up in the separator could probably be improved and separator strength increased, thus lengthening the separator life to a point where race subsurface fatigue became the limiting factor. In that connection even further improvement could

Table XI
COMPUTED BEARING FORCES

| | Critical Speeds | | Bearing Force at Upper Critical at $\alpha = 720 \text{ Rad/Sec}^2$ | Bearing Force During Deceleration at $\alpha = 2$ 15.4 Rad/Sec ² |
|-----------------------------|------------------|--------------------|--|---|
| | Vertical Mode | Horizontal Mode | | |
| Present | | | | |
| Configuration "A" | 25,821 | 766 | | |
| KBRG | 27,878 | 789 | 1,200 lb | 8,250 lb |
| $K_2 = 215,000 \text{ psi}$ | 36,143 | 34,696 | | |
| $K_3 = 31,000 \text{ psi}$ | | | | |
| Configuration "B" | | | | |
| KBRG | 788 | | | |
| $K_2 = 1,000 \text{ psi}$ | 862 | | | |
| $K_3 = 1,000 \text{ psi}$ | 35,831 | | | |
| Configuration "C" | | | | |
| $K_1 = 10,000 \text{ psi}$ | 6,059 | 765 | | |
| $K_2 = 100,000 \text{ psi}$ | 9,894 | 789 | 60 to 70 lb | 410 to 478 |
| $K_3 = 3,115 \text{ psi}$ | 10,456 | 6,683 | | |
| Configuration "D" | | | | |
| $K_1 = 10,000 \text{ psi}$ | 6,337 | | | |
| $K_2 = 200,000 \text{ psi}$ | 13,904 | | | |
| $K_3 = 200,000 \text{ psi}$ | 14,380 | | | |
| Configuration "E" | | | | |
| $K_1 = 10,000 \text{ psi}$ | 6,440 | | | |
| $K_2 = 400,000 \text{ psi}$ | 19,567 | | | |
| $K_3 = 400,000 \text{ psi}$ | 19,663 | | | |
| Configuration "F" | | | | |
| $K_1 = 20,000 \text{ psi}$ | 6,871 | | | |
| $K_2 = 75,000 \text{ psi}$ | 8,554 | | 37 lb | 253 lb |
| $K_3 = 75,000 \text{ psi}$ | 11,252 | | | |
| Configuration "G" | | | | |
| $K_1 = 40,000 \text{ psi}$ | 7,305 | | | |
| $K_2 = 75,000 \text{ psi}$ | 8,663 | | 85 lb | 582 lb |
| $K_3 = 75,000 \text{ psi}$ | 14,861 | | | |

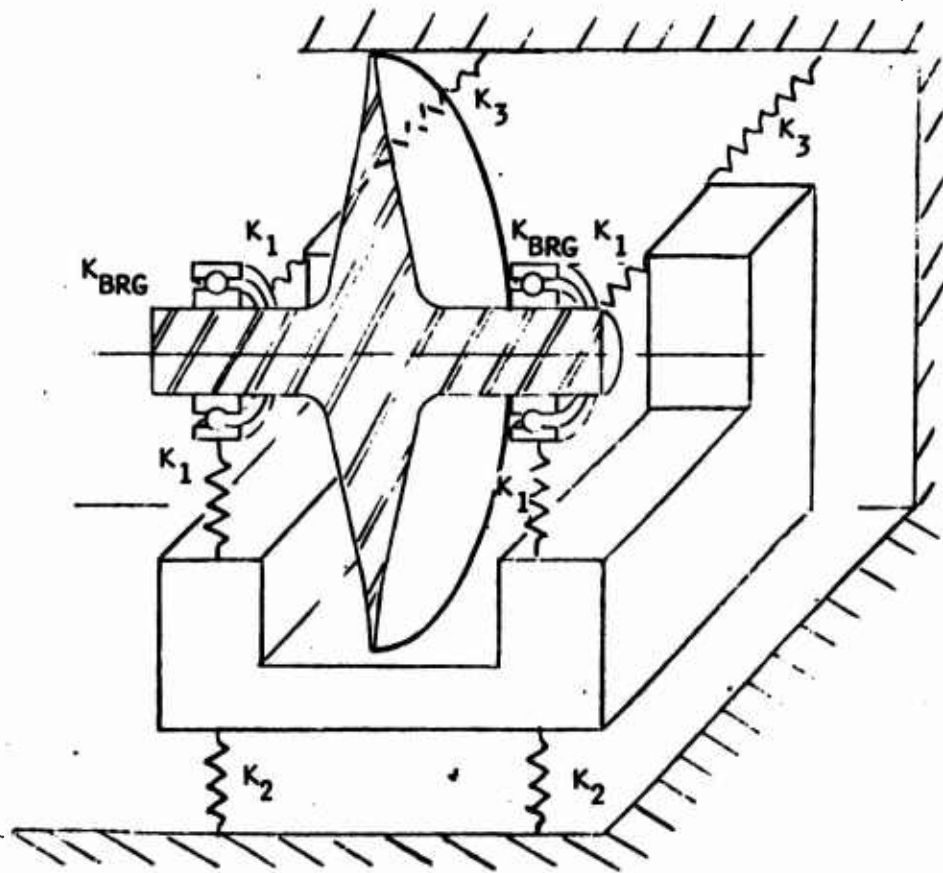

Figure 27. Spring System Schematic

be made by the use of improved steel, such as M-50 tool steel. In addition to improved fatigue life, the M-50 races would allow higher preload, thus reducing the ball path eccentricity, which causes the major loading on the separator.

In addition to using improved bearings, the problem of meeting precessional loads can be ameliorated through redesign of the flywheel. This redesign would involve a smaller diameter, higher speed flywheel of "chunkier" cross section.

A reduction in diameter reduces the precessional loads proportionately. However, a reduction in diameter also increases the base width of the optimized flywheel such that the bearings can be spaced wider apart without changing the resonant vibration conditions. Thus, decreasing the diameter of the flywheel effectively reduces the precessional loads by approximately a factor of two. In addition, it reduces the windage losses by the 1.8 power of the reduction in radius.

The only disadvantage of decreasing the diameter of the optimized flywheel is that it causes the speed to increase in the same proportion. This increase in speed increases the operating DN value of the support bearings, unless the bore diameter is also decreased. Each individual application must be analyzed for its own operating condition; however, it can be generalized that as the speed increases, the torque in the shaft decreases. This would suggest that the DN value for the bearings can usually be held down to acceptable limits regardless of the diameter of the flywheel, until the speed exceeds the practical limits of gearing.

Tilt Table Simulator testing established that by using the best available balancing technology, there will be essentially no problems with resonant vibration conditions induced by the flywheel itself.

It is believed that the poor correlation between measured and computed vibration results indicates that computer results cannot be relied upon for future flywheel designs. This would suggest that resonance conditions induced by flywheel out of balance should be tested for early in the fabrication program of energy storage substations.

Another principle demonstrated by the Tilt Table Simulator is that it is feasible to use a single gear mesh to couple a hydraulic rotating group to a high speed flywheel.

The vacuum system used in the flywheel was demonstrated to be adequate even though it was of small capacity and was a gear pump design. It is believed that a near optimum size was used when its size is considered to be a trade-off between pump power consumption versus flywheel aerodynamic power loss.

Section IV

INTERMITTENT DUTY CYCLE SIMULATOR

A. BASIC TEST OBJECTIVES

The specific objective of the Intermittent Duty Cycle Simulator endurance tests was to demonstrate the use of a flywheel as a source of energy for accomplishing an intermittent actuation function. As a result of this demonstration and the data which were created, the feasibility and weight improvement of applying the flywheel energy storage concept to this type of aircraft actuation function could be evaluated. To this end the XB-70 landing gear extension and retraction cycles were selected. The nature of this duty cycle identifies it as "intermittent" in that it has short periods of peak demand followed by long quiescent periods of zero demand.

Two endurance tests were planned to demonstrate the flywheel's adaptability to utility (intermittent duty cycle) functions. Each of these demonstrations were to operate the simulated XB-70 landing gear through 10,000 cycles. The first demonstration employed a hydraulic motor-pump to supply energy to, and extract energy from, the flywheel. The second demonstration blocked off the pumping function and used the motor-pump solely as a motor to supply energy to the flywheel. Energy was extracted through the power takeoff (PTO) shaft on the gearbox and delivered to the simulated landing gear through a clutch-brake unit and a mechanical hinge.

Figures 28 and 29 are simplified schematic diagrams of the two test arrangements. Figure 30 is a detailed schematic diagram of the simulator showing both hydraulic and mechanical power extraction equipment.

B. HYDRAULIC POWER EXTRACTION SYSTEM AND ENDURANCE TEST

Hydraulic power extraction is accomplished by causing the motor-pump hydraulic unit to assume a pumping mode at the time, or shortly after the time, that gear up or gear down is selected. The conversion from pumping to motoring is accomplished by sensing the pressure drop in the supply line that occurs as the flow capacity of the main system pump is exceeded.

It will be noted that the control of the hydraulic actuator stroke versus time is accomplished by a system employing electrically controlled servo valves. This arrangement was selected principally because the equipment and the technology to successfully implement and maintain it throughout the 10,000 cycles of testing, was readily available in the Structures Laboratory where the Intermittent Duty Cycle Simulator (XB-70 Landing Gear Simulator) was located. This equipment has, in the past, been used to control the hydraulic actuators used to apply fatigue test loading to large aircraft structures.

Duty cycle control was accomplished through a stroke versus time duty cycle curve plotted on a constant speed rotating drum. A curve following device compared the plotted position of this curve with the position of the landing gear as supplied by a position transducer which was fastened

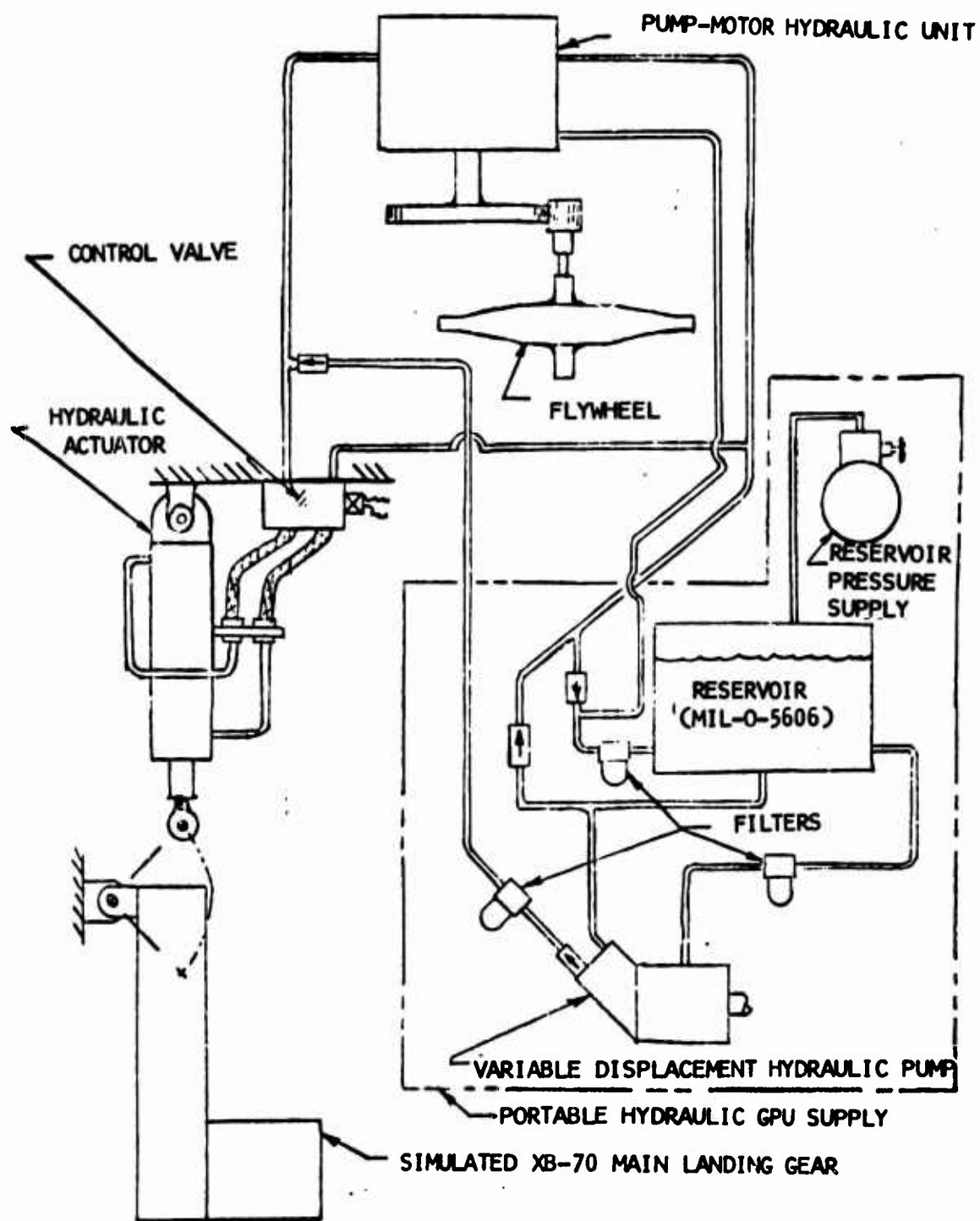

Figure 28. Hydraulic Power Extraction System

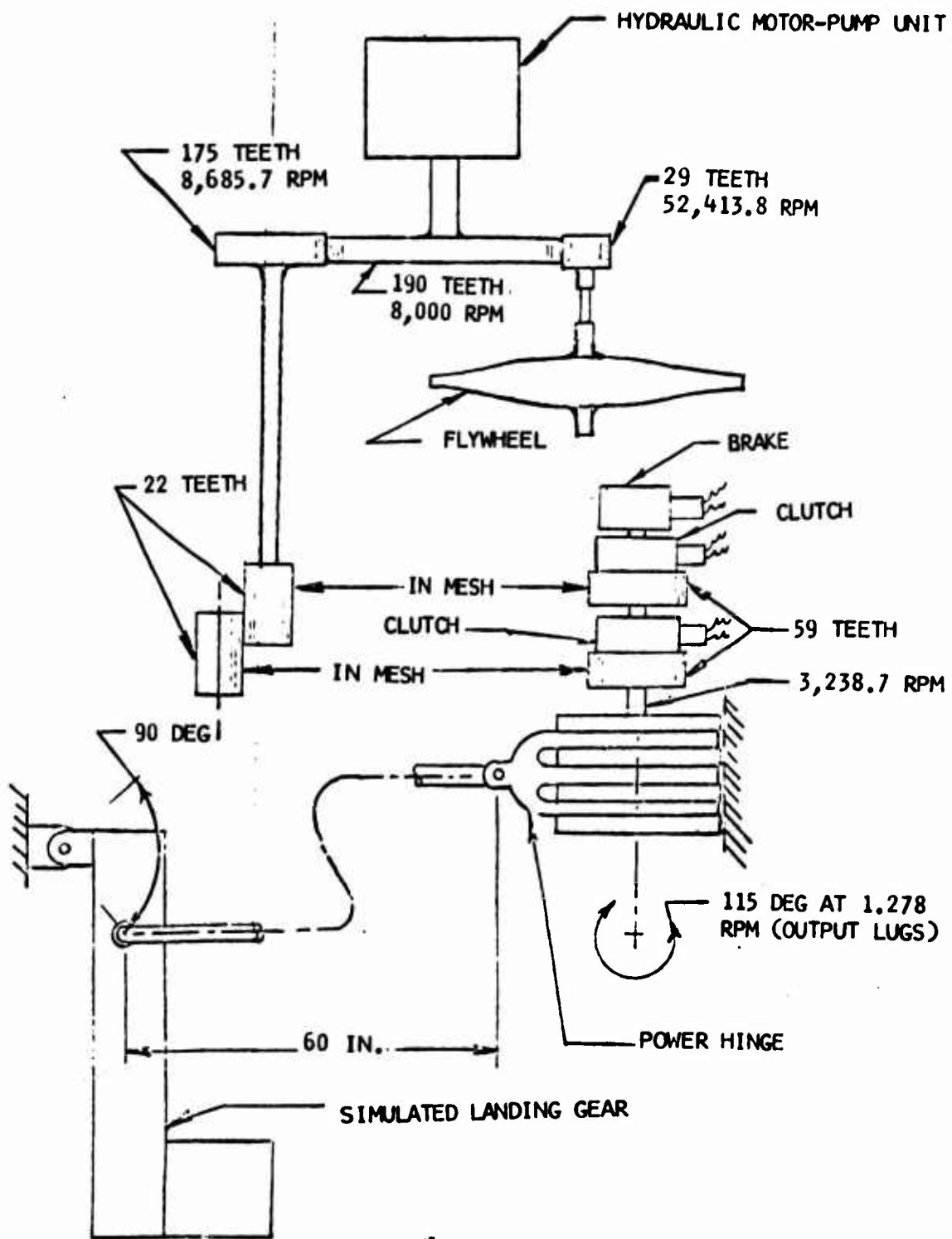
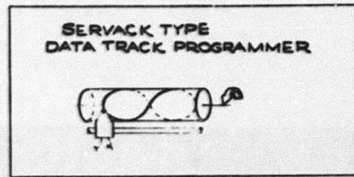
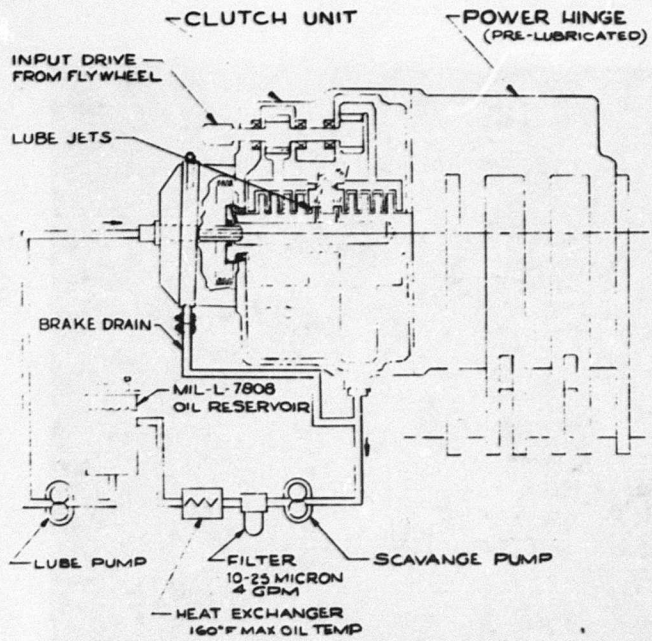
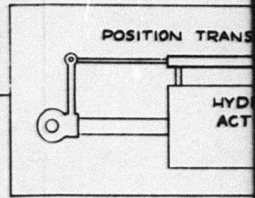

Figure 29. Mechanical Power Extraction System



DEMAND SIGNAL TO SERVO

POSITION FEEDBACK FOR RATE CONTROL



SERVO VALV

FROM ELECTRIC DRIVEN HYDRAULIC POWER SUPPLY (SEE ZONE 3 FOR SCHEMATIC)

FROM ELECTRIC DRIVEN HYDRAULIC POWER SUPPLY SEE ZONE 3 FOR SCHEMATIC

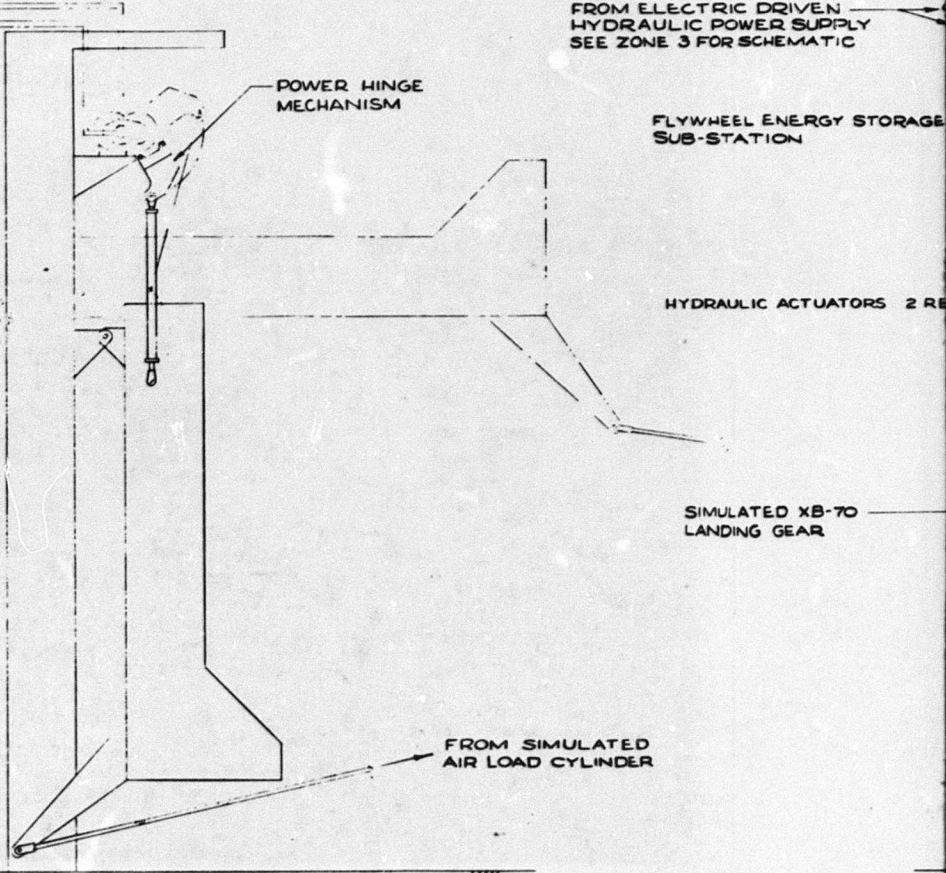

A

INTERMITTENT DUTY CYCLE SIMULATOR MECHANICAL POWER EXTRACTION

ELECTRIC TORQUE MOTOR
HYDRAULIC SERVO VALVE
PROVIDES CONTROLLED RATE FOR BOTH GEAR EXTEND AND RETRACT

DEMAND SIGNAL TO SERVO

POSITION TRANSDUCER

HYDRAULIC ACTUATOR

HYDRAULIC POWER

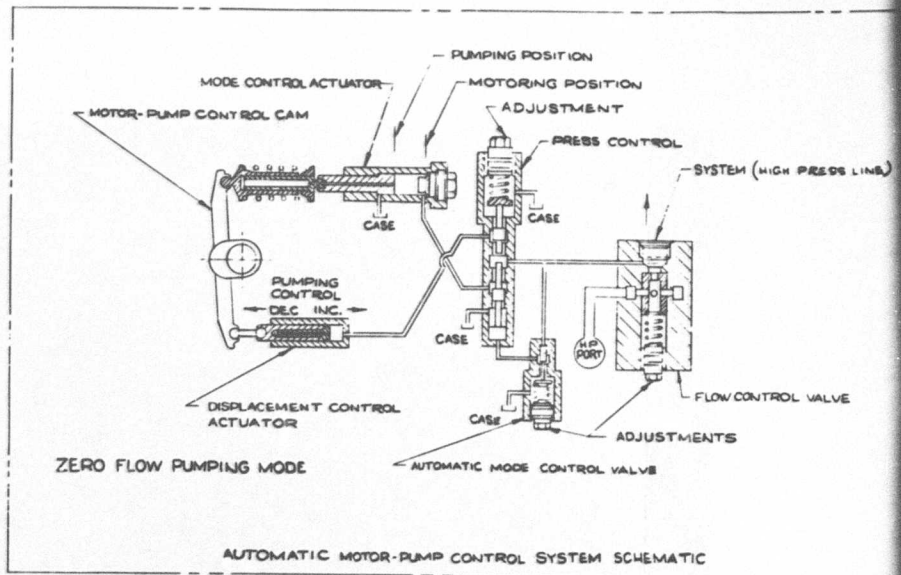

SERVO VALVE

DRIVEN POWER SUPPLY SCHEMATIC

ENERGY STORAGE SECTION

HYDRAULIC ACTUATORS 2 REQD

GEARED XB-70 GEAR

FORCE AIDING RETRACTION
RETARDING EXTENSION

B

INTERMITTENT DUTY CYCLE SIMULATOR
HYDRAULIC POWER EXTRACTION

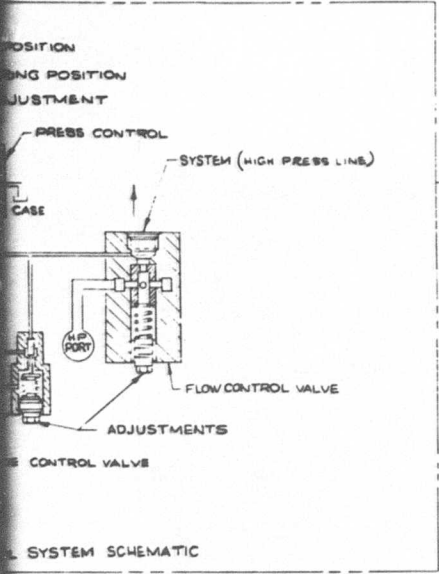

TEMP TRANSDUCER
(GEAR BOX BEARINGS)

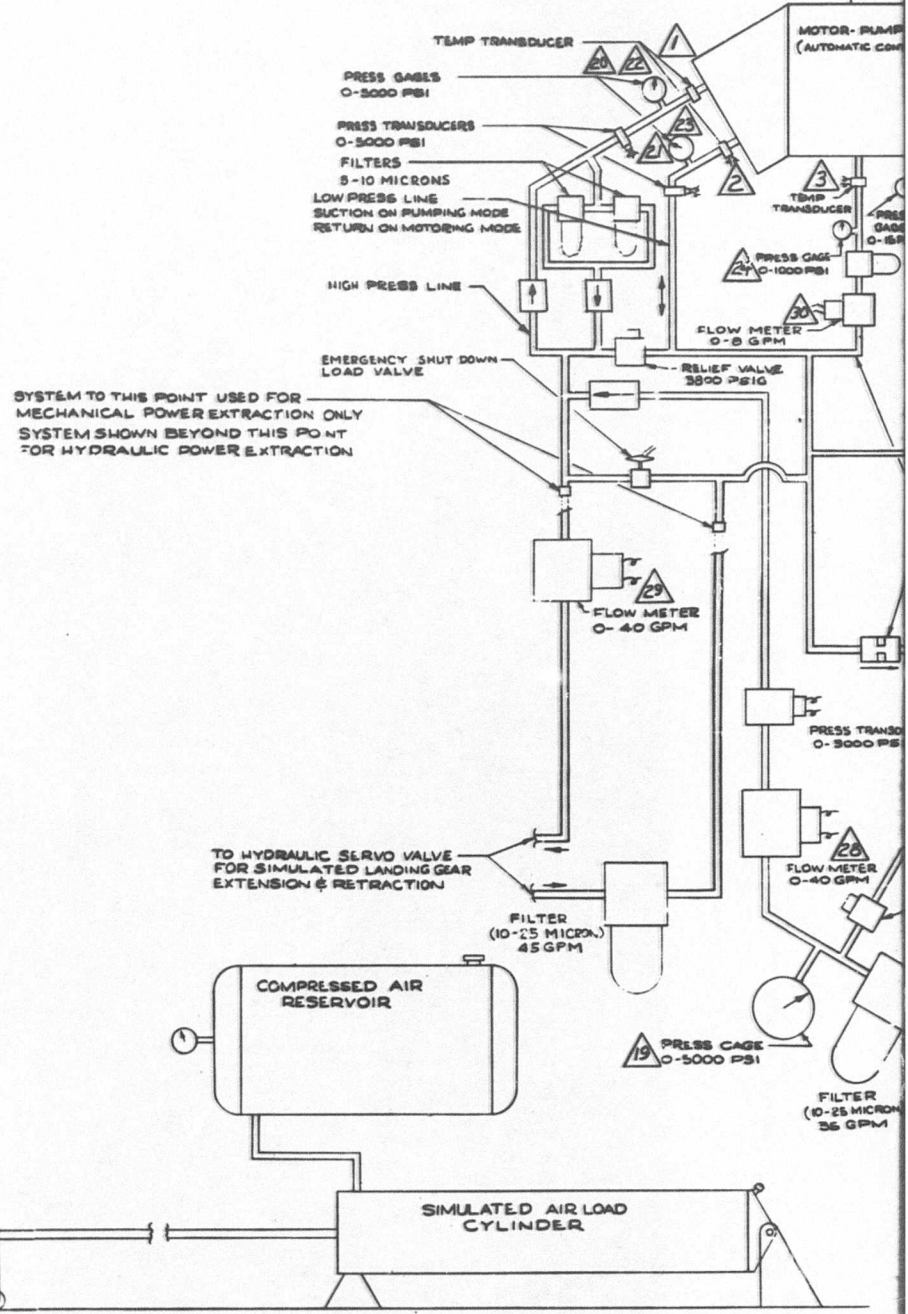

SYSTEM TO THIS POINT USED FOR MECHANICAL POWER EXTRACTION ONLY
SYSTEM SHOWN BEYOND THIS POINT FOR HYDRAULIC POWER EXTRACTION

FORCE AIDING RETRACTION
RETARDING EXTENSION

C

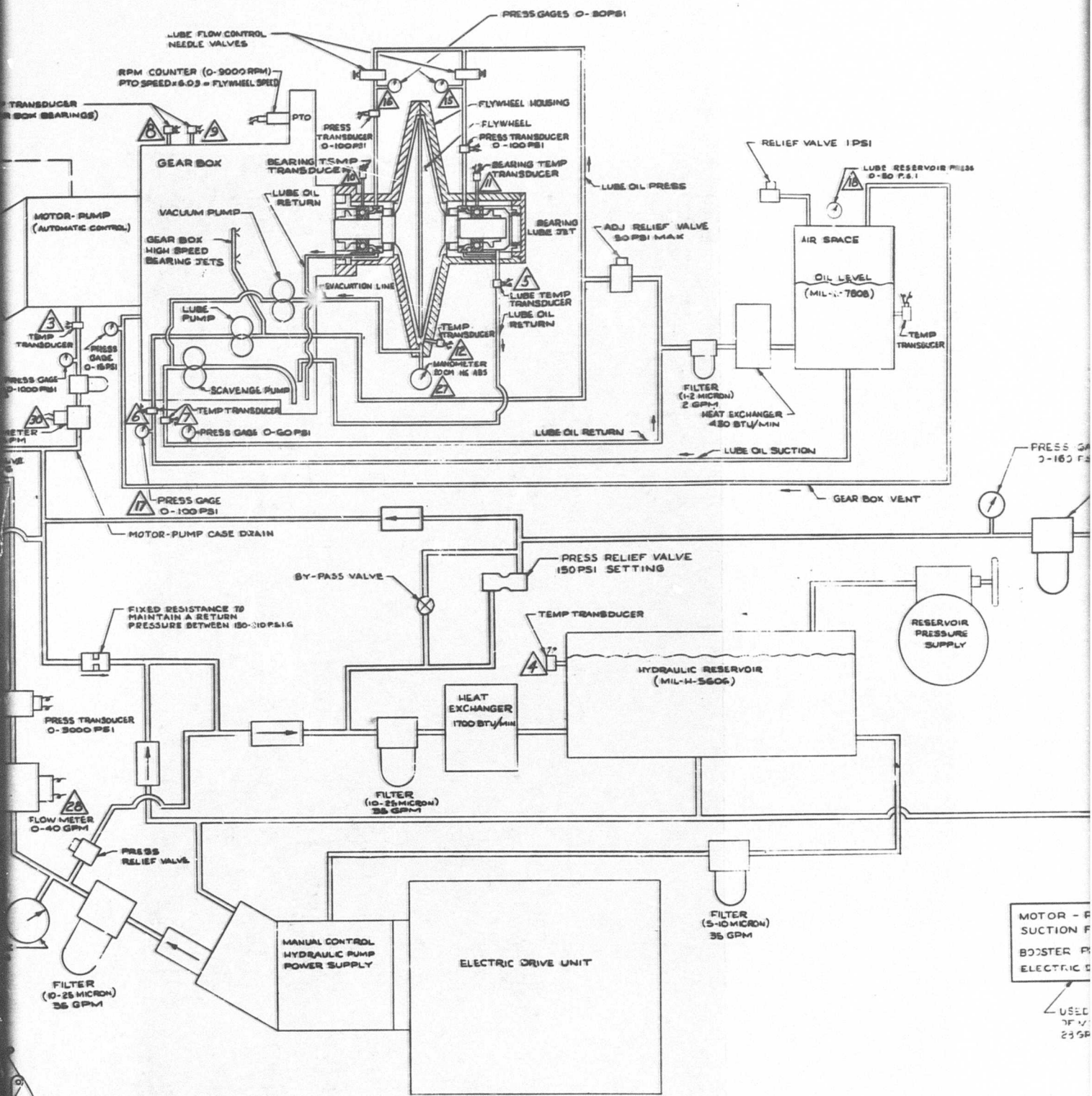

CODE INDICATES TEST POINTS ON DATA SHEETS

SCHEMATIC INTENT

D

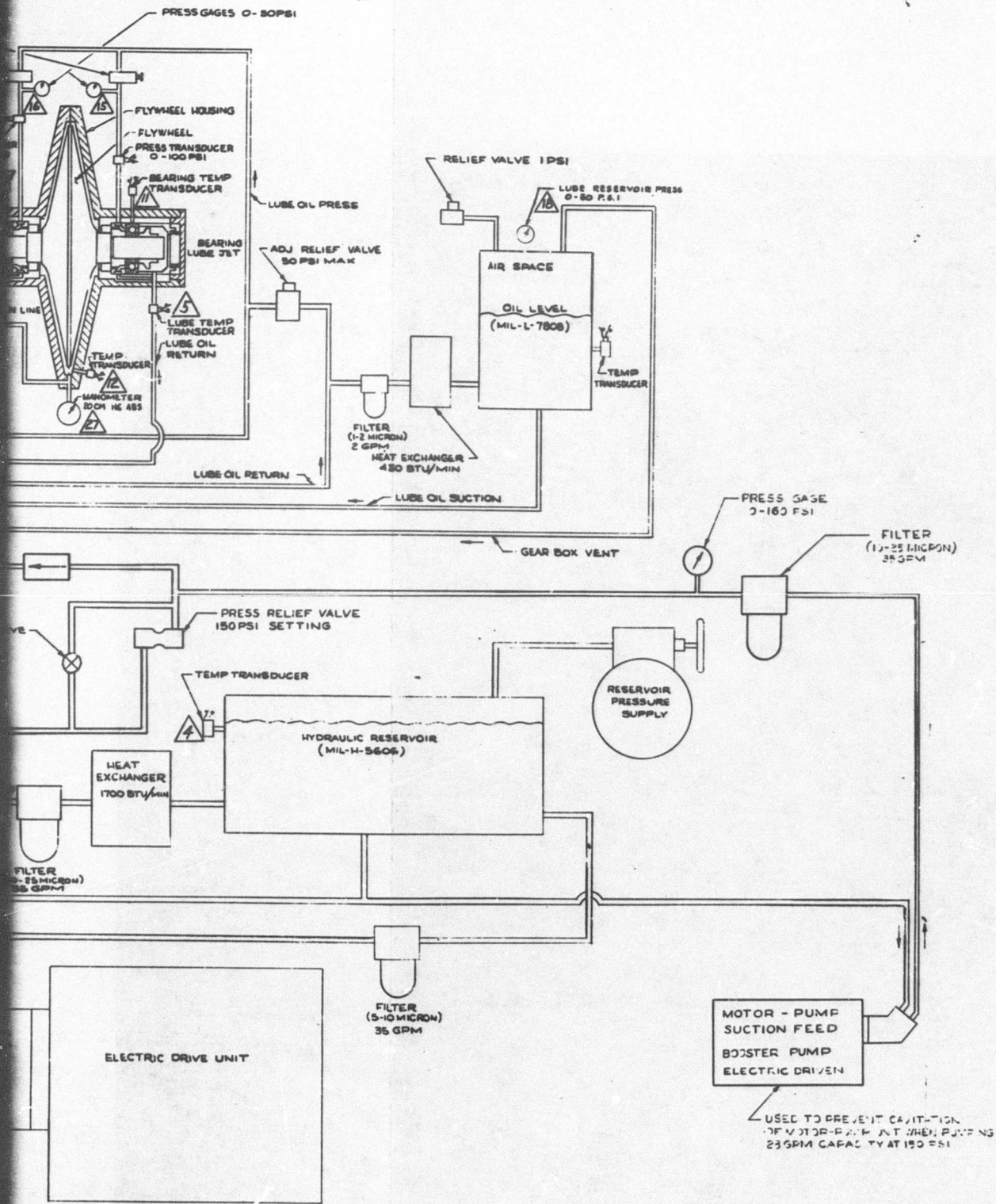

CODE  INDICATES TEST POINTS ON DATA SHEETS

E

Figure 30.

SCHMATIC - ENERGY STORAGE SUBSTATION
INTERMITTENT DUTY CYCLE SIMULATOR
HYDRAULIC AND MECHANICAL
POWER EXTRACTION

to one of the hydraulic actuators. A comparison of the two signals then established an error signal which operated the servo valve controlling the hydraulic supply to the strut actuators.

The principal advantage of using this system, in addition to accurate control, was in the safety provisions which resulted. If the landing gear did not follow the programmed actuation cycle, the servo valve closed, stopping the landing gear. This allowed laboratory personnel to release the airload and lower the gear to the down position as a result of its weight.

Figure 31 is an installation drawing showing both the hydraulic power extraction system and the mechanical power extraction system test setups. With reference to the drawing, the airload was produced by a pneumatic cylinder connected to a large accumulator or storage bottle, which maintained nearly constant pressure. The cable attachment was so located that it would vary the effective moment arm and produce the landing gear trunnion hinge moments shown by the dotted line in figure 32. This moment, when combined with that caused by the landing gear weight and fed through the kinematics closely approximated the requirements.

It will also be noted that the hydraulic power extraction system utilized two (3,000 psi) hydraulic actuators in tandem in lieu of the single (4,000 psi) hydraulic actuator used on the XB-70 air vehicle. When a single (3,000 psi) actuator was considered for this simulator it became apparent that a large side rotating moment would have to be resisted by the trunnion bearings since it (the 3,000 psi actuator) could not be installed on the centerline of the smaller XB-70 actuator. For the 10,000 cycles planned in the endurance test, the dual actuator arrangement appeared more practical.

The endurance test of 10,000 cycles was begun 18 May 1967 and completed 24 June 1967. In attaining this objective, Energy Storage Substation No. 3 operated 132 hours. It had only one failure, which involved the motor-pump. This was near the beginning of the test. The gearbox and flywheel completed the test without incident.

Figures 33 through 37 are photographs showing various views of the test setup. It should be noted that figures 35, 36, and 37 show the emergency generator motor. This unit was not used during the test. The pictures were taken prior to its destruction on the Tilt Table Simulator. The failure is described in a separate section covering operation of that simulator.

Operation of the simulator began using the first delivered automatic New York Airbrake motor-pump after it has been refurbished. This motor-pump failed for the second time after 12 hours (950 cycles) of operation and was replaced with the second automatic New York Airbrake unit. Shortly after this unit began operation it too began discharging abnormal quantities of chips through its case drain line. Although New York Airbrake representatives felt that the conditions under which this motor-pump, and most of its predecessors, had been operated was satisfactory and could not account for the failures, it was decided to increase the low case pressures (0 to 10 psi) by replumbing the simulator so that case pressure equaled return pressure (100 to 200 psi). As soon as this was done, the rate of chip generation decreased dramatically to normal limits and remained there for the rest of

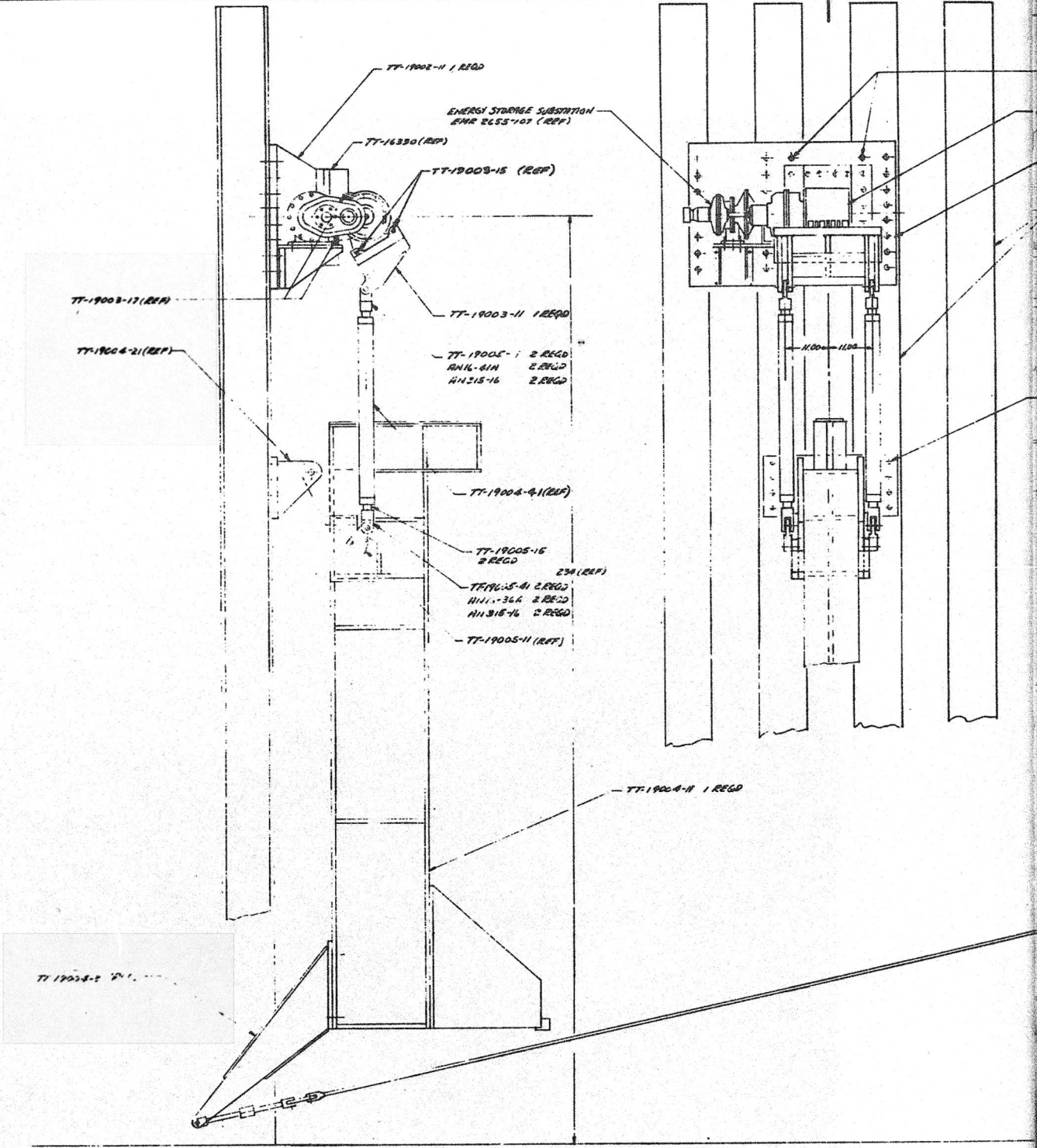

UNITED AIRCRAFT CORPORATION, INC.
 LOS ANGELES DIVISION
 INTERNATIONAL AVIATION, LOS ANGELES 4, CALIFORNIA
 43307 FRAME
 TT-19001

A

12

11

10

①

B-70 KING FOLD DECKING

TP-19008-21 (REF)

ADJUSTMENT

②

TO AIR CYLINDER

TP-19006-21 (REF)

ADJUSTMENT

254.00 (REF)

170.00

TP-19006-21 (REF)

STEERING GEAR

12

11

10

B

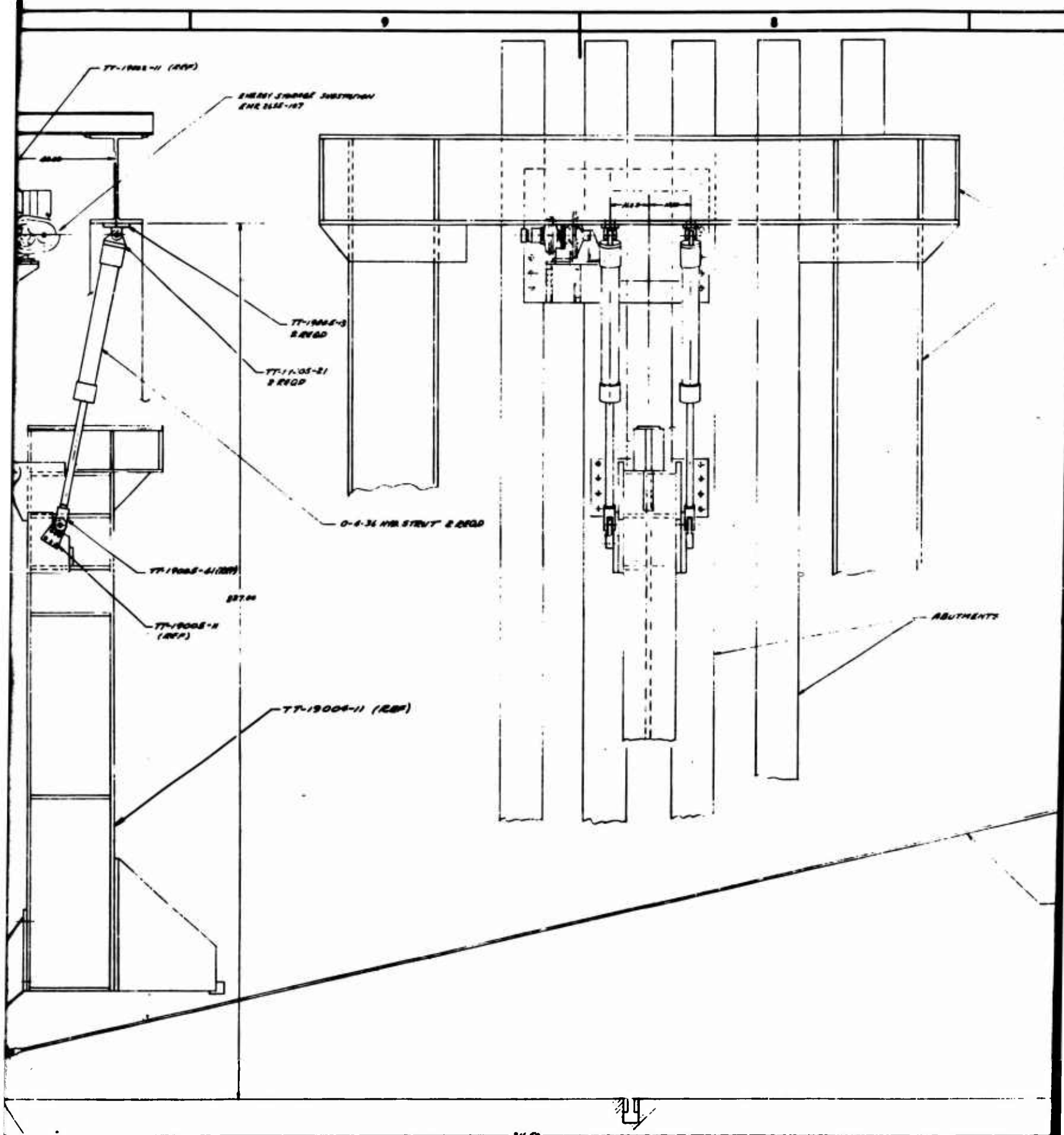

STORM GASE LOAD LMC ①

| | |
|-------------------------|--|
| CRANE FRAME TT-19001 | |
|-------------------------|--|

c

7

6

8

TRUSS FRAME

ABUTMENTS

TRUSS

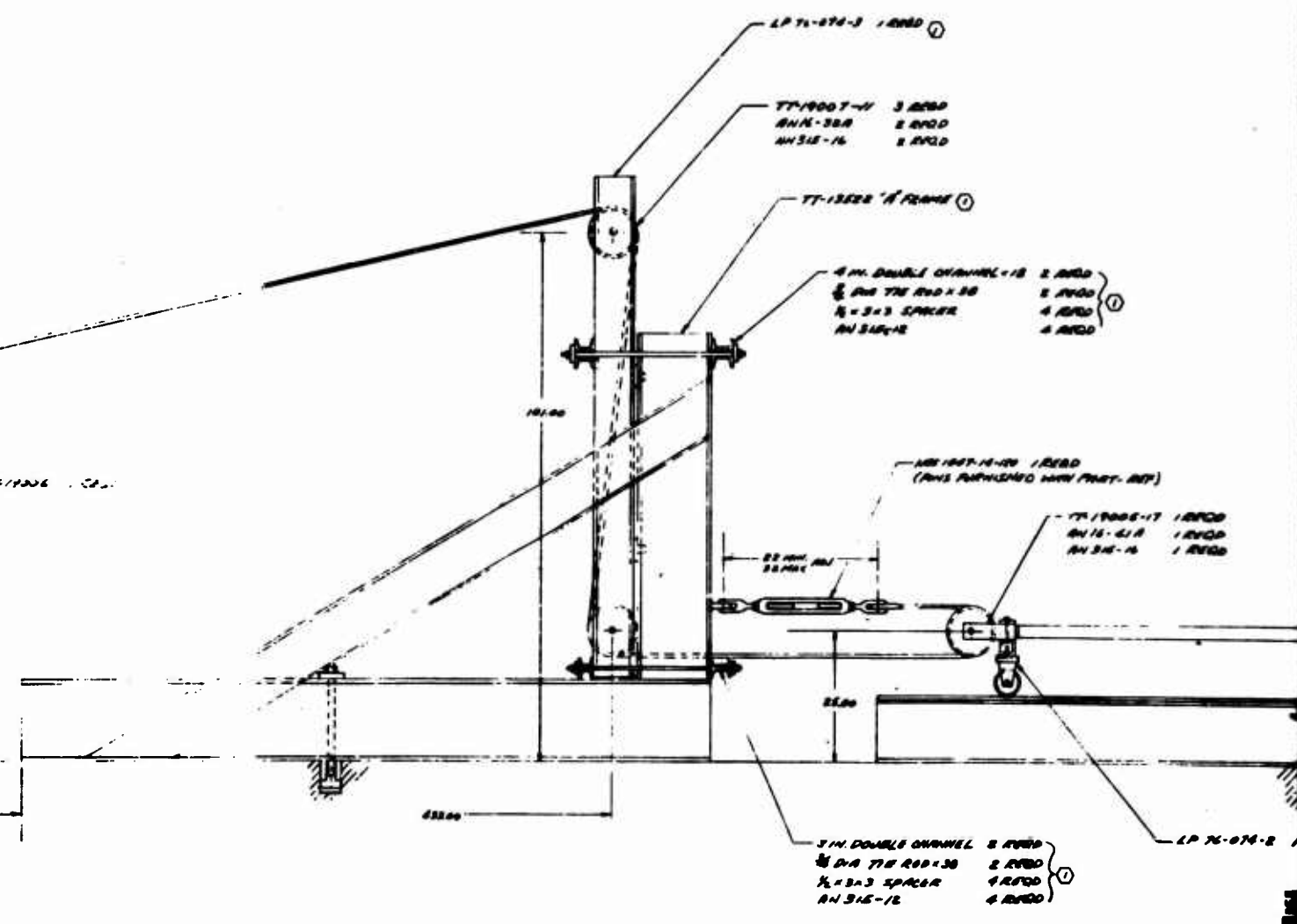

7

6

5

D

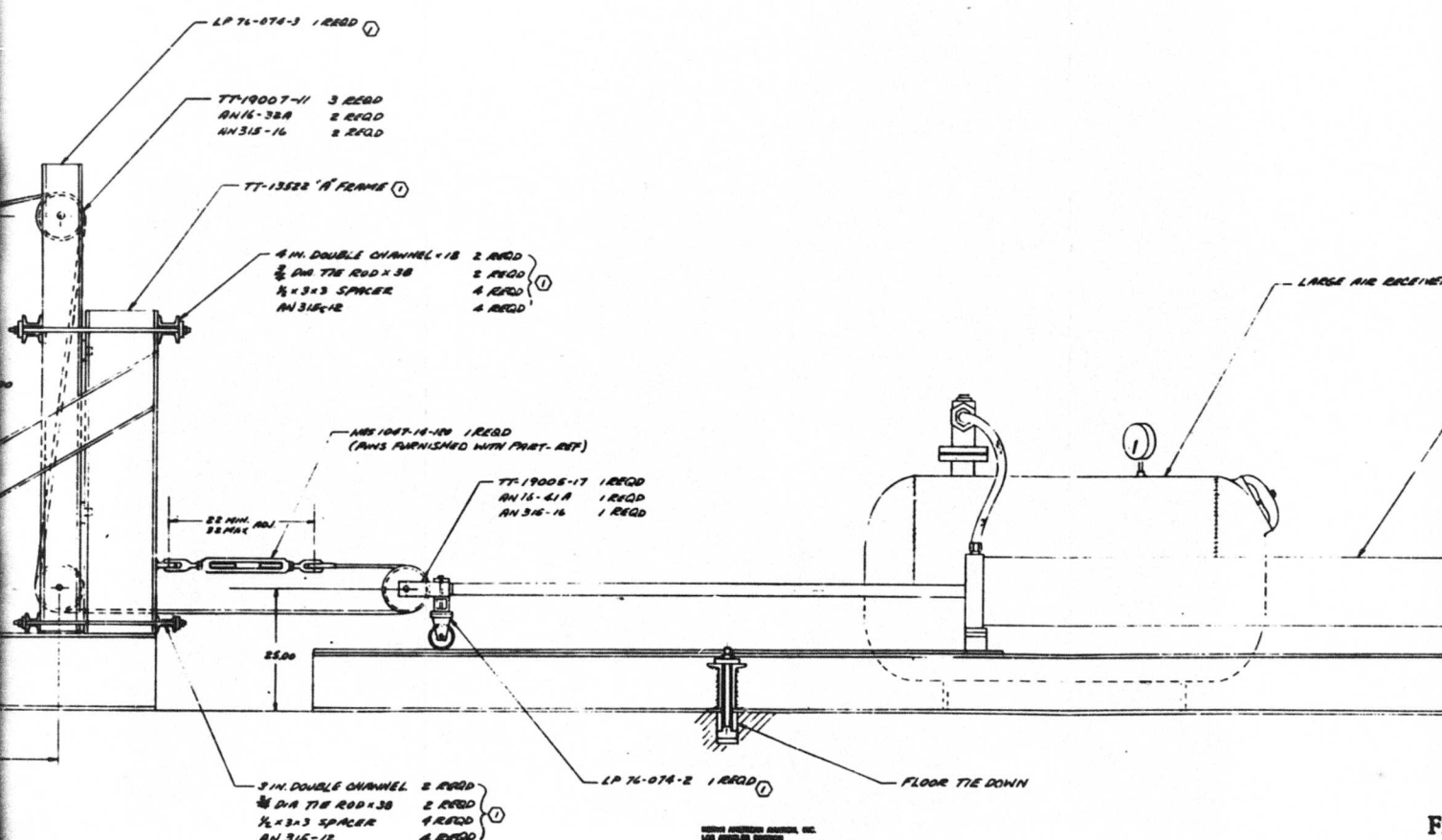

WORLD AVIATION SERVICE, INC.
125 WASHINGTON AVENUE, LOS ANGELES 12, CALIFORNIA

| | | |
|----------|-------|----------|
| TT-19000 | FRAME | ONE REQD |
| TT-19001 | | |

E

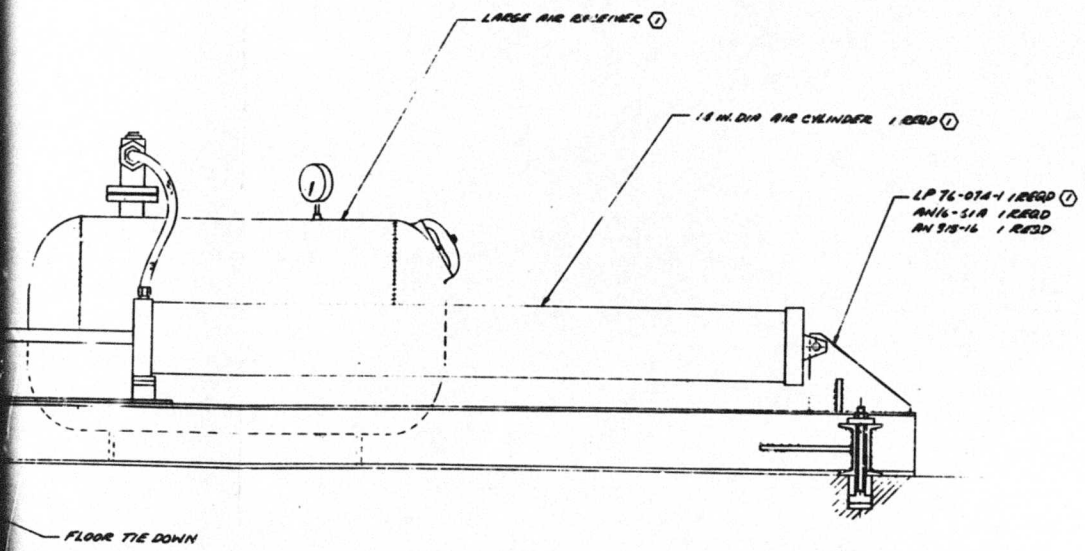

Figure 31. Installation - Energy Storage Substation Landing Gear Simulator

BLANK PAGE

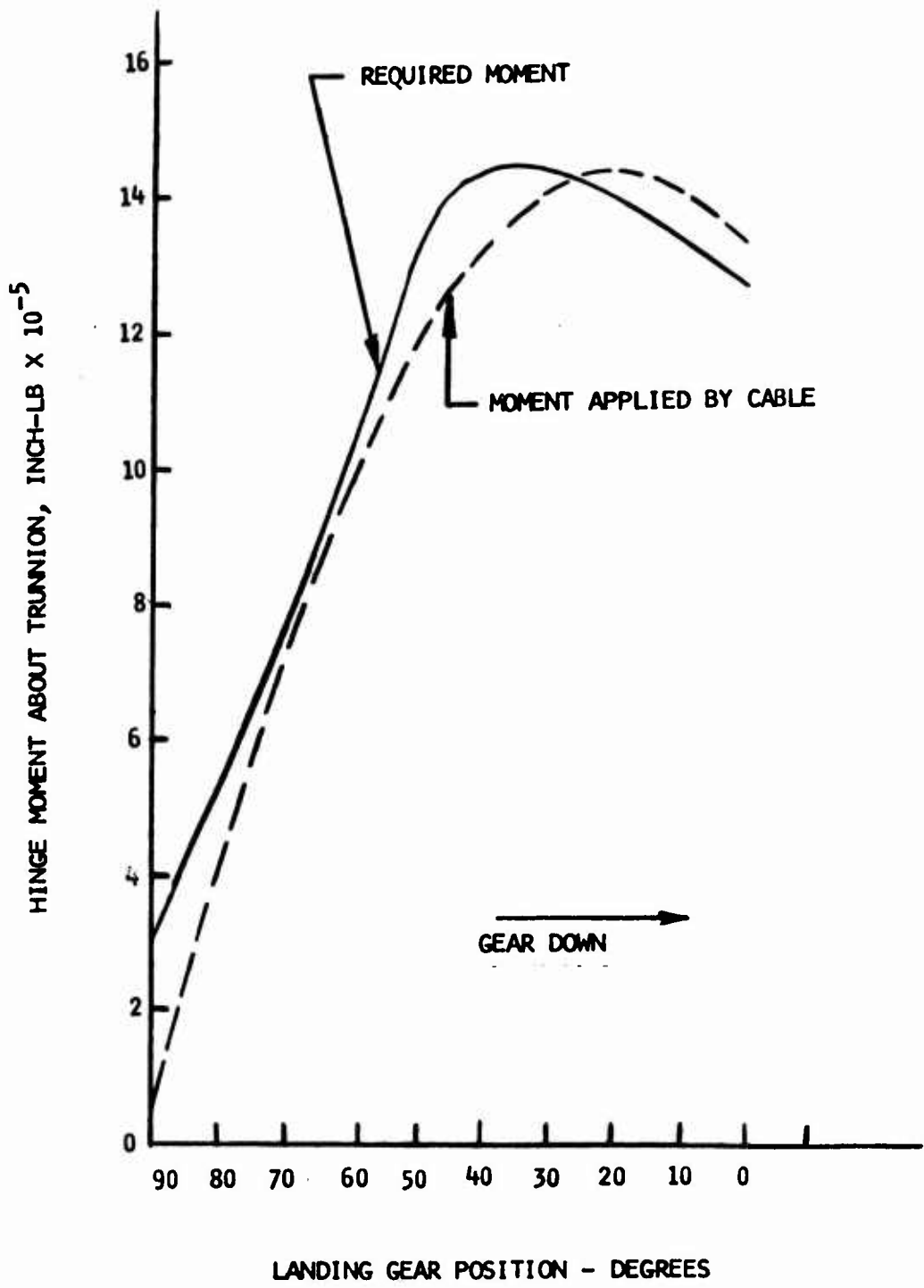

Figure 32. Simulated Airload on Landing Gear

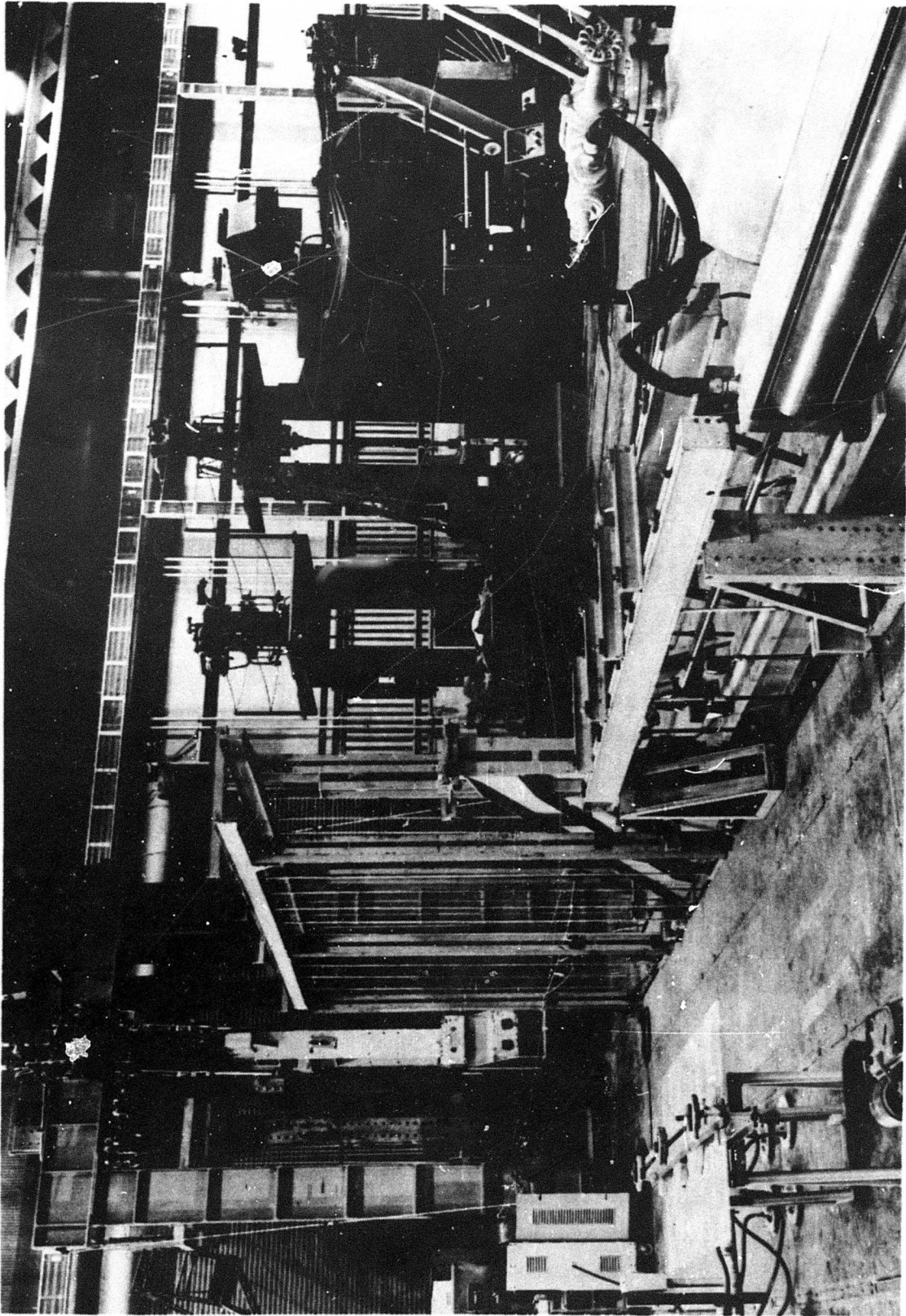

Figure 33. Intermittent Duty Simulator - Panoramic View Showing Air Load Cylinder

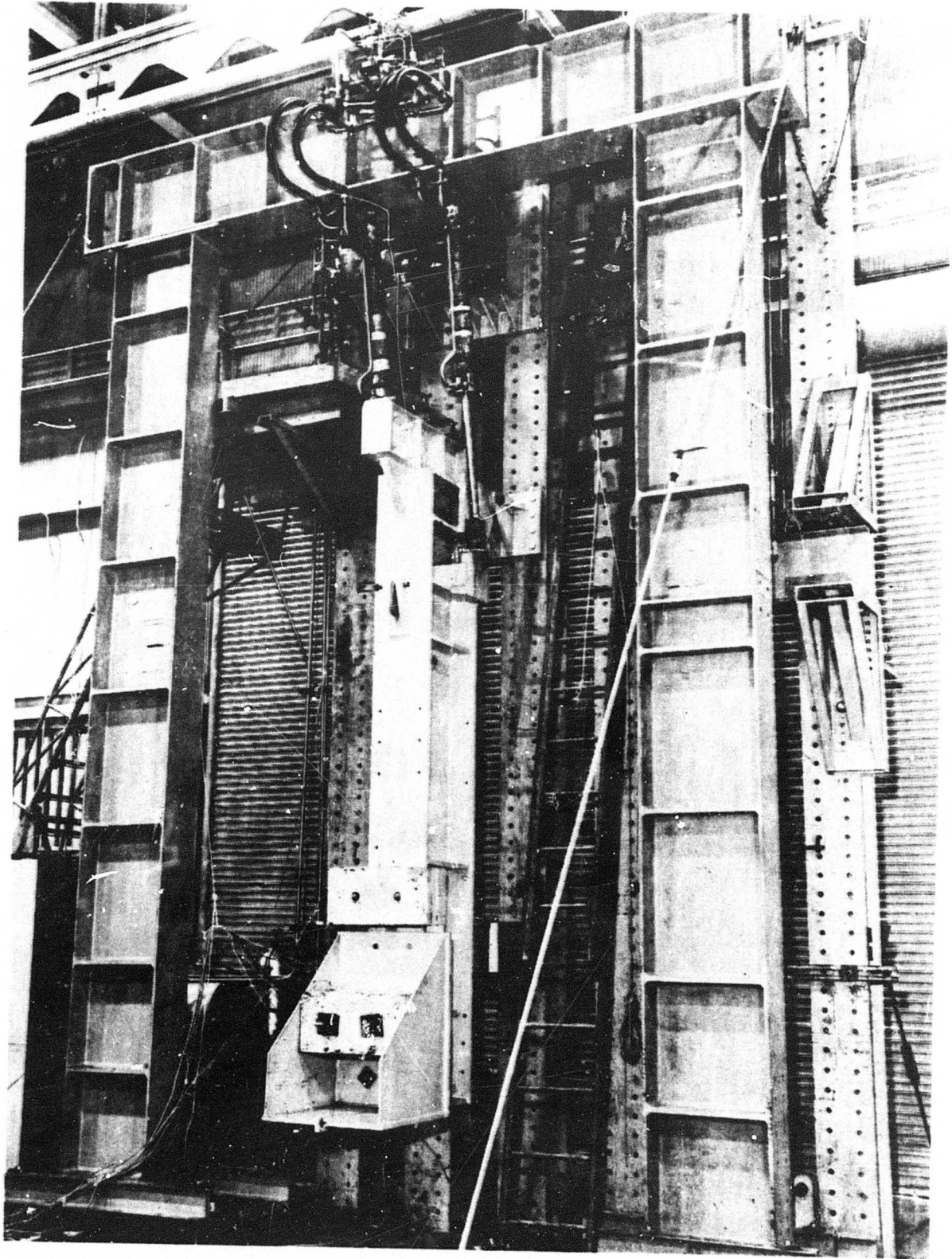

Figure 34. Intermittent Duty Simulator - Hydraulic Installation

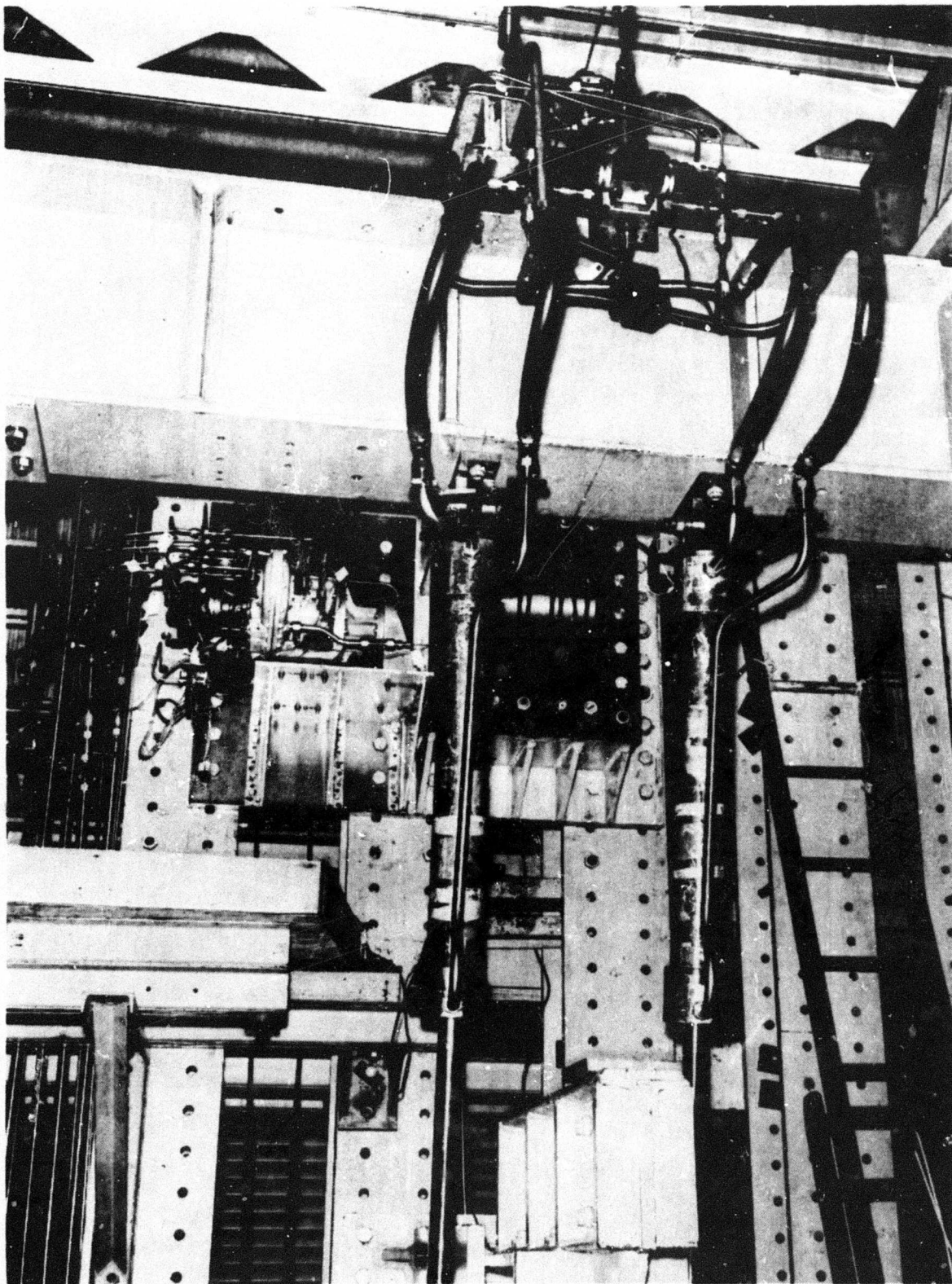

Figure 35. Intermittent Duty Simulator - Hydraulic Installation Closeup

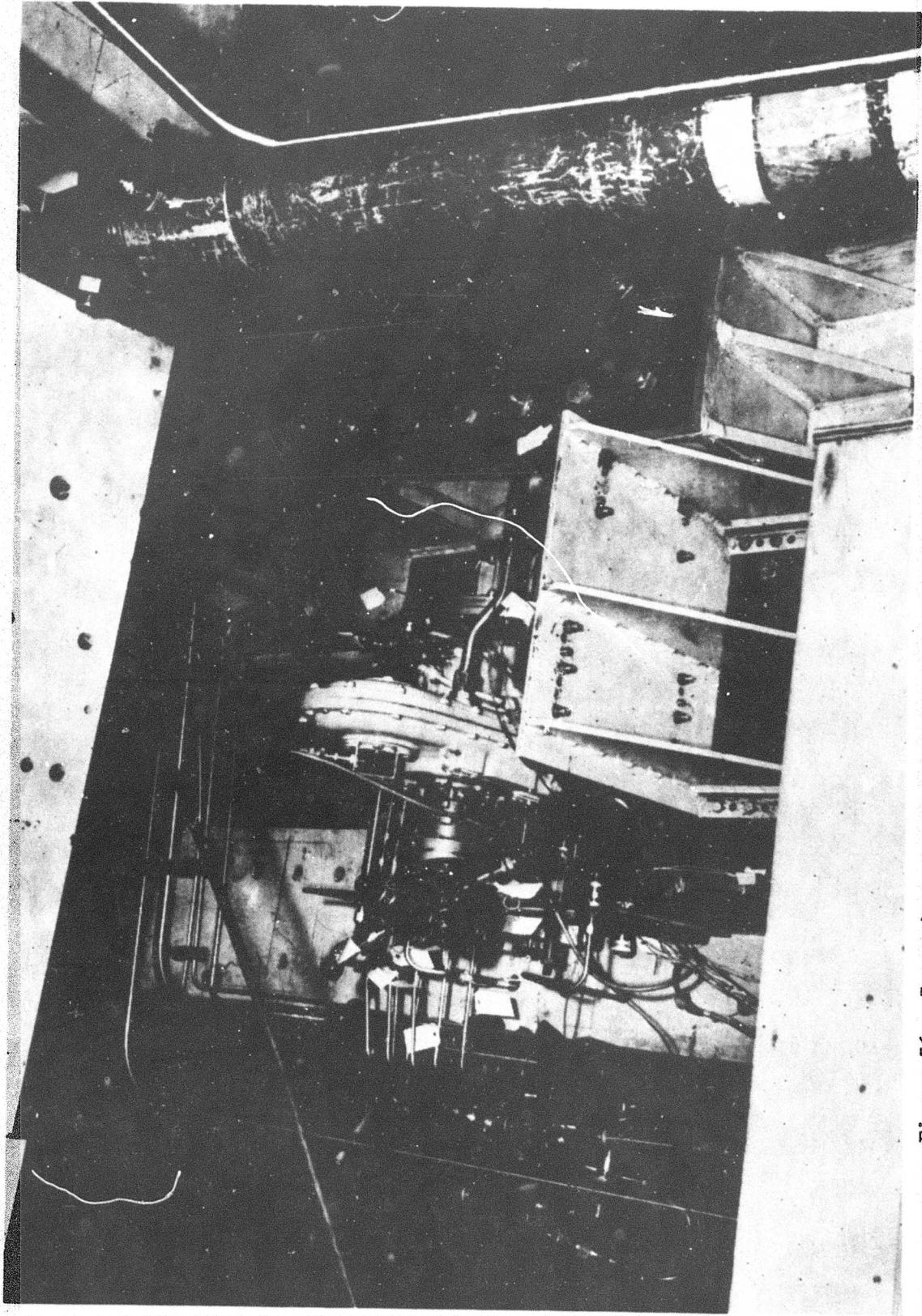

Figure 36. Intermittent Duty Simulator - Energy Storage Substation Close-up

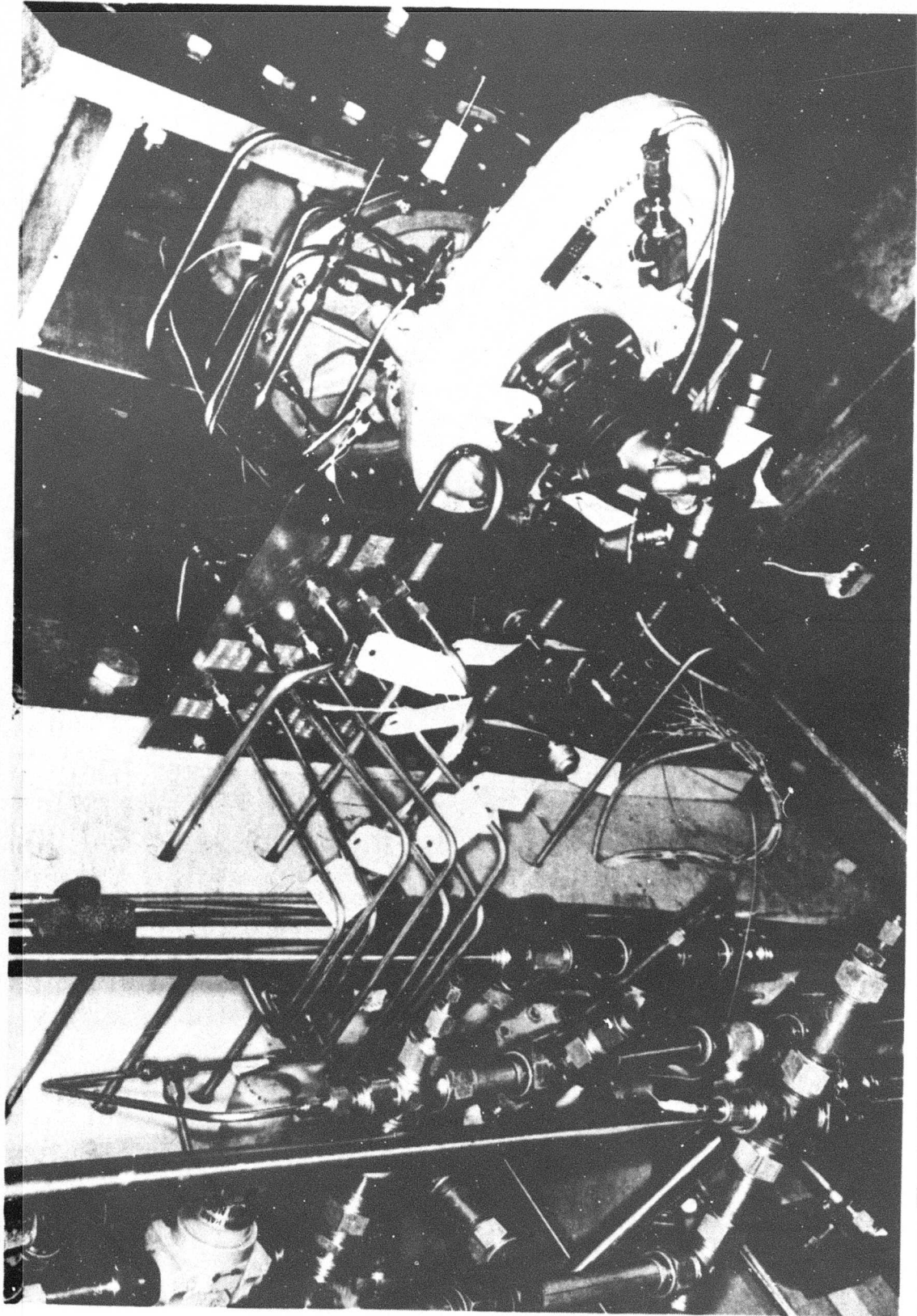

Figure 37. Intermittent Duty Simulator - Energy Storage Substation Closeup (Front View)

the tests. At present, there is still no satisfactory analytical explanation for the improvements resulting from this change. However, it should be pointed out that, from that time until the end of the program all motor-pump operation used the high case pressure approach and no further motor-pump failures occurred. In fact, from that time forward, motor-pump performance was excellent.

At the beginning of the endurance test the flywheel had three manometers. One read flywheel hub absolute pressure, one read flywheel differential from the hub to the tip and a third read barometric pressure at the flywheel tip. During the initial stages of simulator operation it was observed that these manometer lines connected with the flywheel housing would gradually fill with oil. This led to false manometer readings. It was believed that this phenomenon stemmed from peculiarities of the vacuum system. Upon shutdown, the vacuum pump discharge line would siphon a small amount of return oil backward through the meshing gear teeth of the vacuum pump due to residual vacuum in the flywheel housing. Upon startup the bulk of this oil would gradually be scavenged from the housing by the flywheel rotation. In the process, however, the high tip speed of the wheel would vaporize some of the oil it contacted and send the vapors into all parts of the vacuum system. The manometer lines being lower than the substation by about 25 feet, and cooler due to room temperature exposure, would recondense the vapors, trapping the liquid on top of the columns of mercury. The condition was remedied by deleting two of the manometers which were considered nonessential and installing the third manometer above the substation. It supplied absolute pressure at the flywheel tip and was read through a telescope near the test panel. An electrically operated dump valve was also installed at the drain line from the flywheel housing. The dump valve was operated just as substation shutdown was initiated. The line was left open until the next startup and only a small amount of dripping occurred. This was believed to be exclusively rotary seal leakage, since a slight amount of carbon discoloration could usually be detected. With operation as outlined above a close surveillance of the condition of the rotary seals was possible throughout the endurance test. The surveillance indicated that there was no significant change in leakage throughout the test.

During the course of testing most of the interruptions resulted from failures in the landing gear test fixture and its associated commercial and/or instrumentation equipment. The commercial hydraulic actuators, which raise and lower the simulated landing gear strut, were initially designed with aluminum pistons that seal to the barrel by means of an O-ring that is banded on its outside diameter by a teflon ring or "slipper". The nature of the seal installation coupled with the manner in which the actuator was used allowed extrusion of the seal through the piston-to-barrel clearance. An excessive amount of clearance had built up as a result of the actuator's previous usage. This fact plus the large moment on the rod end tending to cock the piston in the barrel led to piston seal extrusion. The same large moment conditions also led to several actuator rod seal failures. Prior to beginning the endurance test, during simulator fabrication, the actuators were refurbished with new seals. New piston and/or rod seals were also installed after 2,756, 4,030, 5,734, and 8,505 cycles due to leakage or excessive bypassing of fluid past the pistons. The condition was improved during the

course of the refurbishments by machining new pistons which had less clearance, and honing the barrels to a very smooth finish. The rod end and cylinder head pivot bearings on these actuators began to gall and bind between the bolt and bearing inside diameter after only a few cycles. Bearing and bolt replacements were made but this only brought temporary relief. The bolts were then drilled and fitted for grease injection. This change, together with periodic grease injection (every 100 cycles), corrected the problem.

After approximately 5,200 cycles, it was observed that a strand of the steel cable which applies the equivalent airload to the strut had broken. This signaled the beginning of cable deterioration, and the cable assembly was therefore replaced. Since this is a relatively inexpensive item and since its failure could result in extensive damage to surrounding equipment, several spare cables were procured with the intent of periodic replacement throughout the remaining portions of the endurance tests. (This cable arrangement would be operative throughout the mechanical power extraction endurance tests as well as those of the hydraulic power extraction.)

Prior to beginning Intermittent Duty Cycle Simulator testing, it became apparent that it would be necessary to operate at landing gear speeds somewhat above that which are used by the XB-70 air vehicle. (The XB-70 air vehicle requires 12.5 seconds to extend the strut and 7.5 seconds to retract the strut.) The Intermittent Duty Cycle Simulator was operated with a 6-second extend time and a 5-second retract time. The dwell time in the up position was 16-1/2 seconds while the dwell time in the extended position was 13 seconds.

This speedup in rate resulted from the fact that the displacement of the motor-pump unit as a motor equals its displacement as a pump and the additional fact that the motor is a fixed (maximum) displacement device at all times when it is in a motoring mode. As a result of this fact the ground power unit (GPU) (the test equivalent of the engine-driven pumps) was required to supply sufficient flow to the motor to wind the flywheel up to 53,000 rpm (i.e., 13.5 gpm plus leakage). This flow, supplied to the two commercial cylinders used to raise and lower the landing gear, was sufficient, all by itself, to raise and lower the gear in the 12- to 15-second operating time range. Under these conditions no power extraction demands would be made on the energy storage substation. In order to draw power from the substation it would, therefore, either be necessary to increase the size of the actuating cylinders or reduce the operating time to approximately one half. It was elected to reduce the operating time to the aforementioned 6 seconds extend and 5 seconds retract.

The data from this test are shown in table XII (three pages). Figure 38 is a sample data record taken during a gear-down and gear-up cycle.

Based on the data gathered during the Intermittent Duty Cycle Endurance Test, table XIII was created to summarize performance characteristics. This summary indicates that the efficiency of extracting power during gear-down and gear-up is 58.7 and 44.5 percent, respectively. (Items t and u.) The losses which go into making up this efficiency can be categorized into those

Table XII

INTERMITTENT DUTY CYCLE SIMULATOR TEST DATA
(HYDRAULIC POWER EXTRACTION)

Data Sheet No. 1

| Date | 5-18 | 5-23 | 5-24 | 5-24 | 6-2 | 6-3 | 6-5 | 6-7 | | |
|---|--|---------|---------|---------|---------|---------|---------|---------|---------|------|
| Accum. Running Time of Test - Hours | 1.0 | 3.2 | 7.9 | 13.0 | 19.4 | 25.1 | 30.9 | 37.4 | | |
| Total Operation Load Cycles | 50 | 100 | 500 | 950 | 1500 | 2000 | 2500 | 3000 | | |
| Vibration Amp. at Flywheel Bearings g's | Inboard | 7.3 | 6.7 | 6.7 | 6.5 | 5.3 | 5.9 | 5.7 | 4.9 | |
| | Outboard | 7.3 | 7.9 | 7.8 | 7.8 | 7.4 | 7.4 | 7.7 | 6.4 | |
| Flywheel Speed at Full Motoring - RPM | 50400 | 52550 | 52550 | 51600 | 50800 | 50750 | 50950 | 51750 | | |
| Minimum Speed Attain Under Load - RPM | 45018 | 45350 | 45950 | 45650 | 44650 | 44250 | 44750 | 45550 | | |
| Average Operational Time Sec./Cycle | Gear Up | 8 | 5 | 5 | 5 | 5 | 5 | 5 | | |
| | Gear Down | 10 | 6 | 6 | 6 | 6 | 6 | 6 | | |
| Dwell Time - Seconds | Gear Up | 25 | 13 | 13 | 13 | 13 | 13 | 13 | | |
| | Gear Down | 25 | 16-1/2 | 16-1/2 | 16-1/2 | 16-1/2 | 16-1/2 | 16-1/2 | | |
| Max. Load on Gear - lbs. | Gear Up | 5519 | 5580 | 5720 | 5630 | 5775 | 5725 | 5770 | 5860 | |
| | Gear Down | 7582 | 7635 | 7580 | 7590 | 7780 | 7635 | 7590 | 8010 | |
| NO. TEMPERATURE DATA - DEG. F | | | | | | | | | | |
| 1 | Test Motor - Pump Inlet Temp. | 94 | 108 | 113 | 116 | 105 | 105 | 107 | 101 | |
| 2 | Test Motor - Pump Return Temp. | 97 | 109 | 112 | 114 | 102 | 105 | 105 | 109 | |
| 3 | Test Motor - Pump Case Drain Temp. | 133 | 147 | 146 | 144 | 145 | 148 | 146 | 147 | |
| 4 | Main Hyd. Reservoir Supply Temp. | 99 | 124 | 118 | 118 | 99 | 103 | 102 | 101 | |
| 5 | Gear Box Lube Oil Return Temp. | 170 | 185 | 180 | 177 | 192 | 180 | 169 | 194 | |
| 6 | Gear Box Lube Oil Suction Temp. | 72 | 75 | 75 | 74 | 68 | 70 | 69 | 72 | |
| 7 | Gear Box Scavenger Oil Return Temp. | 149 | 161 | 153 | 151 | 156 | 158 | 150 | 163 | |
| 8 | Gear Box Brg. Adj. Pump Temp. | 158 | 173 | 167 | 165 | 170 | 171 | 175 | 173 | |
| 9 | Gear Box Brg. Adj. Flywheel Temp. | 177 | 197 | 192 | 189 | 192 | 195 | 190 | 195 | |
| 10 | Inboard Flywheel Bearing Temp. | 165 | 185 | 178 | 176 | 179 | 184 | 176 | 185 | |
| 11 | Outboard Flywheel Bearing Temp. | 158 | 178 | 170 | 165 | 173 | 176 | 168 | 177 | |
| 12 | Flywheel Case Housing Temp. | 152 | 172 | 154 | 154 | 172 | 171 | 150 | 175 | |
| NO. SYSTEM PRESSURE DATA - PSIG | | | | | | | | | | |
| 13 | Actuator Press - Tension-Gear Up | 3048 | 3388 | 3120 | 3100 | 3115 | 3240 | 3020 | 3270 | |
| 14 | Actuator Press - Comp.-Gear Down | 3093 | 3137 | 3060 | 3100 | 3340 | 3090 | 3050 | 3390 | |
| 15 | Outboard Flywheel Bearing Press. | 38.0 | 39.8 | 39.2 | 39.7 | 40.7 | 41.1 | 41.6 | 40.1 | |
| 16 | Inboard Flywheel Bearing Press. | 37.4 | 39.0 | 39.5 | 39.7 | 40.7 | 39.7 | 40.4 | 39.5 | |
| 17 | Lube Pump Pressure Port Press. | 50 | 50 | 50 | 50 | 50 | 50 | 50 | 50 | |
| 18 | Lube Reservoir Press. | 0 | 0 | 0 | 0 | 0 | 0 | 0 | 0 | |
| 19 | Hyd. Supply Pump Press. at Source | 3400 | 3415 | 3390 | 3390 | 3340 | 3352 | 3450 | 3400 | |
| 20 | Test Motor - Pump Port Pressures (Pumping) | Press. | 3080 | 3009 | 2550 | 2444 | 2910 | 2840 | 2800 | 2810 |
| 21 | | Return | 66 | 129 | 157 | 168 | 173 | 172 | 175 | 156 |
| 22 | Test Motor - Pump Port Pressures (Motoring) | Press. | 3344 | 3539 | 3480 | 3520 | 3328 | 3310 | 3311 | 3330 |
| 23 | | Return | 130 | 139 | 188 | 171 | 188 | 192 | 192 | 170 |
| 24 | Test Motor - Pump Case Drain Press. | 155-210 | 155-210 | 155-210 | 155-210 | 155-210 | 155-210 | 155-208 | 153-205 | |
| 25 | Vacuum at Flywheel Hub - in. Hg | 29.6 | — | — | — | — | — | — | — | |
| 26 | Vacuum from Hub to Tip (ΔP) in. Hg | .6 | — | — | — | — | — | — | — | |
| 27 | Press. at Flywheel Hub - Ca. Hg. Ab. | 1.5 | 3.2 | 3.6 | 3.5 | 3.3 | 3.5 | 3.5 | 3.5 | |
| NO. FLUID FLOW DATA | | | | | | | | | | |
| 28 | Hyd. Supply Pump Flow - GPM | 17.6 | 18.3 | 18.0 | 19.3 | 18.7 | 19.0 | 20.2 | 18.5 | |
| 29 | Inlet Flow to Servo - GPM | 20.8 | 32.0 | 31.2 | 31.4 | 31.3 | 34.0 | 35.2 | 33.6 | |
| 30 | Case Drain of Motor - GPM | .7 | .65 | .7 | .65 | .55 | .3-55 | .3-55 | .3-55 | |
| 31 | Outb'd. Bearing Lube Flow cc/min | 550 | 550 | 555 | 575 | 595 | 595 | 595 | 595 | |
| 32 | Inb'd. Bearing Lube Flow cc/min | 540 | 570 | 580 | 590 | 610 | 610 | 610 | 610 | |
| 33 | Axial Vib. | 11.3 | 10.6 | 10.6 | 10.0 | 13.9 | 15.8 | 15.3 | 15.2 | |

Table XII (Continued)

INTERMITTENT DUTY CYCLE SIMULATOR TEST DATA
(HYDRAULIC POWER EXTRACTION)

Data Sheet No. 2

| Date | 6-7 | 6-8 | 6-9 | 6-15 | 6-15 | 6-20 | 6-21 | 6-21 | | |
|---|--|---------|-----------|-----------|-----------|-----------|-----------|-----------|-----------|---------|
| Accum. Running Time of Test - Hours | 43.3 | 49.5 | 55.7 | 62.1 | 68.6 | 74.9 | 80.8 | 86.9 | | |
| Total Operation Load Cycles | 3500 | 4000 | 4500 | 5000 | 5500 | 6000 | 6500 | 7000 | | |
| Vibration Amp. at Flywheel Bearings g's | Inboard | 5.3 | 5.3 | 6.7 | 6.3 | 5.5 | 5.9 | 12.6 | 6.0 | |
| | Outboard | 6.7 | 8.8 | 7.8 | 7.4 | 6.8 | 7.2 | 12.9 | 7.1 | |
| Flywheel Speed at Full Motoring - RPM | 52650 | 51850 | 52050 | 53000 | 50800 | 51100 | 52050 | 52050 | | |
| Minimum Speed Attain Under Load - RPM | 45550 | 45550 | 45450 | 46000 | 45400 | 45400 | 46500 | 46500 | | |
| Average Operational Time Sec./Cycle | Gear Up | 5 | 5 | 5 | 5 | 5 | 5 | 5 | | |
| | Gear Down | 6 | 6 | 6 | 6 | 6 | 6 | 6 | | |
| Dwell Time - Seconds | Gear Up | 13 | 13 | 13 | 13 | 13 | 13 | 13 | | |
| | Gear Down | 16-1/2 | 16-1/2 | 16-1/2 | 16-1/2 | 16-1/2 | 16-1/2 | 16-1/2 | | |
| Max. Load on Gear - lbs. | Gear Up | 5710 | 6010 | 5440 | 5945 | 5350 | 5205 | 5450 | 5150 | |
| | Gear Down | 7580 | 8010 | 7240 | 7920 | 7225 | 6940 | 7370 | 6980 | |
| NO. TEMPERATURE DATA - DEG. F | | | | | | | | | | |
| 1 | Test Motor - Pump Inlet Temp. | 106 | 98 | 105 | 110 | 110 | 110 | 114 | 105 | |
| 2 | Test Motor - Pump Return Temp. | 104 | 100 | 105 | 120 | 109 | 115 | 112 | 108 | |
| 3 | Test Motor - Pump Case Drain Temp. | 145 | 142 | 150 | 147 | 146 | 147 | 150 | 150 | |
| 4 | Main Hyd. Reservoir Supply Temp. | 100 | 98 | 105 | 105 | 105 | 110 | 106 | 105 | |
| 5 | Gear Box Lube Oil Return Temp. | 190 | 165 | 161 | 187 | 178 | 165 | 185 | 205 | |
| 6 | Gear Box Lube Oil Suction Temp. | 70 | 70 | 73 | 71 | 70 | 71 | 74 | 75 | |
| 7 | Gear Box Scavenger Oil Return Temp. | 153 | 150 | 155 | 158 | 160 | 155 | 154 | 165 | |
| 8 | Gear Box Brg. Adj. Pump Temp. | 167 | 163 | 167 | 170 | 173 | 165 | 169 | 185 | |
| 9 | Gear Box Brg. Adj. Flywheel Temp. | 189 | 185 | 192 | 191 | 195 | 190 | 191 | 201 | |
| 10 | Inboard Flywheel Bearing Temp. | 175 | 170 | 178 | 177 | 184 | 178 | 178 | 194 | |
| 11 | Outboard Flywheel Bearing Temp. | 166 | 162 | 166 | 169 | 175 | 172 | 170 | 187 | |
| 12 | Flywheel Case Housing Temp. | 150 | 140 | 144 | 148 | 170 | 147 | 154 | 180 | |
| NO. SYSTEM PRESSURE DATA - PSIG | | | | | | | | | | |
| 13 | Actuator Press - Tension-Gear Up | 3280 | 3280 | 3300 | 3320 | 3295 | 3290 | 3260 | 3250 | |
| 14 | Actuator Press - Comp.-Gear Down | 3260 | 3360 | 3340 | 3460 | 3340 | 3325 | 3350 | 3320 | |
| 15 | Outboard Flywheel Bearing Press. | 40.3 | 41.0 | 41.3 | 40.7 | 40.5 | 41.1 | 40.6 | 41.1 | |
| 16 | Inboard Flywheel Bearing Press. | 39.9 | 40.2 | 39.5 | 40.4 | 39.1 | 40.0 | 39.1 | 39.5 | |
| 17 | Lube Pump Pressure Port Press. | 50 | 50 | 50 | 50 | 50 | 50 | 50 | 50 | |
| 18 | Lube Reservoir Press. | 0 | 0 | 0 | 0 | 0 | 0 | 0 | 0 | |
| 19 | Hyd. Supply Pump Press. at Source | 3400 | 3400 | 3400 | 3400 | 3400 | 3400 | 3400 | 3400 | |
| 20 | Test Motor - Pump Port Pressures (Pumping) | Press. | 2900-2700 | 2890-2650 | 2860-2760 | 2940-2890 | 2900-2820 | 2920-2860 | 2960-2750 | |
| 21 | | Return | 143-203 | 150-206 | 145-200 | 163-230 | 164-217 | 172-226 | 169-220 | 163-217 |
| 22 | Test Motor - Pump Port Pressures (Motoring) | Press. | 3300 | 3305 | 3280 | 3350 | 3320 | 3320 | 3340 | 3317 |
| 23 | | Return | 164 | 167 | 151 | 186 | 181 | 186 | 181 | 181 |
| 24 | Test Motor - Pump Case Drain Press. | 153-208 | 154-208 | 153-210 | 156-210 | 153-210 | 156-209 | 153-210 | 156-210 | |
| 25 | Vacuum at Flywheel Hub - in. Hg | — | — | — | — | — | — | — | — | |
| 26 | Vacuum from Hub to Tip (ΔP) in. Hg | — | — | — | — | — | — | — | — | |
| 27 | Press. at Flywheel Hub - Cm. Hg. Ab. | 3.5 | 3.1 | 3.5 | 3.5 | 3.5 | 3.5 | 3.5 | 3.5 | |
| NO. FLUID FLOW DATA | | | | | | | | | | |
| 28 | Hyd. Supply Pump Flow - GPM | 18.3 | 18.3 | 18.0 | 19.8 | 19.6 | 19.6 | 18.5 | 19.2 | |
| 29 | Inlet Flow to Servo - GPM | 34.3 | 34.5 | 34.5 | 33.8 | 35.2 | 36.2 | 33.9 | 30.9 | |
| 30 | Case Drain of Motor - GPM | 3-55 | 3-55 | 3-55 | 3-55 | 3-55 | 3-55 | 3-55 | 3-55 | |
| 31 | Outb'd. Bearing Lube Flow cc/min | 595 | 595 | 595 | 595 | 595 | 595 | 595 | 595 | |
| 32 | Inb'd. Bearing Lube Flow cc/min | 610 | 610 | 610 | 610 | 610 | 610 | 610 | 610 | |
| 33 | Axial Vibration | 14.5 | 13.9 | 13.1 | 12.6 | 11.3 | 13.2 | 12.9 | 13.5 | |

Table XII (Concluded)

INTERMITTENT DUTY CYCLE SIMULATOR TEST DATA
(HYDRAULIC POWER EXTRACTION)

Data Sheet No. 3

| Date | | 6-20 | 6-22 | 6-23 | 6-23 | 6-24 | 6-24 | | |
|---|--|----------|-----------|-----------|-----------|-----------|-----------|-----------|--|
| Accum. Running Time of Test - Hours | | 92.5 | 98.3 | 104.2 | 110.2 | 116.2 | 122.1 | | |
| Total Operation Load Cycles | | 7500 | 8000 | 8500 | 9000 | 9500 | 10000 | | |
| Vibration Amp. at Flywheel Bearings g's | Inboard | 6.4 | 5.5 | 5.9 | 5.7 | 5.7 | 5.9 | | |
| | Outboard | 7.2 | 7.2 | 7.2 | 6.8 | 7.6 | 7.2 | | |
| Flywheel Speed at Full Motoring - RPM | | 54500 | 52500 | 51600 | 52400 | 51600 | 51150 | | |
| Minimum Speed Attain Under Load - RPM | | 49200 | 46500 | 45500 | 47000 | 45500 | 45950 | | |
| Average Operational Time Sec./Cycle | Gear Up | 5 | 5 | 5 | 5 | 5 | 5 | | |
| | Gear Down | 6 | 6 | 6 | 6 | 6 | 6 | | |
| Dwell Time - Seconds | Gear Up | 13 | 13 | 13 | 13 | 13 | 13 | | |
| | Gear Down | 16-1/2 | 16-1/2 | 16-1/2 | 16-1/2 | 16-1/2 | 16-1/2 | | |
| Max. Load on Gear - lbs. | Gear Up | 5650 | 5150 | 5250 | 5250 | 5400 | 5284 | | |
| | Gear Down | 7620 | 7030 | 7270 | 7240 | 7400 | 7270 | | |
| NO. TEMPERATURE DATA - DEG. F | | | | | | | | | |
| 1 | Test Motor - Pump Inlet Temp. | 110 | 110 | 104 | 108 | 105 | 110 | | |
| 2 | Test Motor - Pump Return Temp. | 110 | 109 | 106 | 108 | 106 | 110 | | |
| 3 | Test Motor - Pump Case Drain Temp. | 146 | 147 | 147 | 141 | 147 | 145 | | |
| 4 | Main Hyd. Reservoir Supply Temp. | 105 | 102 | 102 | 100 | 105 | 105 | | |
| 5 | Gear Box Lube Oil Return Temp. | 178 | 172 | 168 | 180 | 183 | 163 | | |
| 6 | Gear Box Lube Oil Suction Temp. | 74 | 72 | 72 | 70 | 72 | 72 | | |
| 7 | Gear Box Scavenger Oil Return Temp. | 154 | 154 | 156 | 160 | 156 | 158 | | |
| 8 | Gear Box Brg. Adj. Pump Temp. | 168 | 174 | 173 | 173 | 175 | 170 | | |
| 9 | Gear Box Brg. Adj. Flywheel Temp. | 190 | 192 | 194 | 198 | 194 | 197 | | |
| 10 | Inboard Flywheel Bearing Temp. | 178 | 178 | 184 | 188 | 181 | 186 | | |
| 11 | Outboard Flywheel Bearing Temp. | 167 | 176 | 176 | 178 | 170 | 173 | | |
| 12 | Flywheel Case Housing Temp. | 154 | 150 | 163 | 175 | 152 | 155 | | |
| NO. SYSTEM PRESSURE DATA - PSIG | | | | | | | | | |
| 13 | Actuator Press - Tension-Gear Up | 3250 | 3270 | 3265 | 3210 | 3240 | 3240 | | |
| 14 | Actuator Press - Comp.-Gear Down | 3360 | 3365 | 3360 | 3320 | 3270 | 3250 | | |
| 15 | Outboard Flywheel Bearing Press. | 40.9 | 41.0 | 41.0 | 41.5 | 41.0 | 41.0 | | |
| 16 | Inboard Flywheel Bearing Press. | 39.5 | 40.0 | 40.0 | 40.0 | 40.0 | 39.9 | | |
| 17 | Lube Pump Pressure Port Press. | 50 | 50 | 50 | 50 | 49 | 49 | | |
| 18 | Lube Reservoir Press. | 0 | 0 | 0 | 0 | 0 | 0 | | |
| 19 | Hyd. Supply Pump Press. at Source | 3400 | 3400 | 3400 | 3400 | 3400 | 3400 | | |
| 20 | Test Motor - Pump Port Pressures (Pumping) | Press. | 2700-2880 | 2705-2830 | 2820-2900 | 2800-2855 | 2805-2920 | 2815-2890 | |
| 21 | | Return | 163-220 | 172-226 | 166-220 | 169-223 | 173-224 | 173-221 | |
| 22 | Test Motor - Pump Port Pressures (Motoring) | Press. | 3320 | 3315 | 3320 | 3330 | 3310 | 3325 | |
| 23 | | Return | 178 | 186 | 183 | 186 | 190 | 185 | |
| 24 | Test Motor - Pump Case Drain Press. | 158-212 | 156-210 | 155-210 | 156-209 | 157-209 | 157-210 | | |
| 25 | Vacuum at Flywheel Hub - in. Hg | --- | --- | --- | --- | --- | --- | | |
| 26 | Vacuum from Hub to Tip (ΔP) in. Hg | --- | --- | --- | --- | --- | --- | | |
| 27 | Press. at Flywheel Hub - Cm. Hg. Ab. | 3.2 | 3.3 | 3.2 | 3.4 | 3.2 | 3.2 | | |
| NO. FLUID FLOW DATA | | | | | | | | | |
| 28 | Hyd. Supply Pump Flow - GPM | 18.6 | 14.1 | 19.4 | 18.7 | 19.5 | 19.6 | | |
| 29 | Inlet Flow to Servo - GPM | 31.4 | 33.4 | 30.7 | 30.7 | 28.0 | 29.3 | | |
| 30 | Case Drain of Motor - GPM | 0.3-0.55 | 0.3-0.55 | 0.3-0.55 | 0.3-0.55 | 0.3-0.55 | 0.3-0.55 | | |
| 31 | Out'd. Bearing Lube Flow cc/min | 595 | 595 | 595 | 595 | 595 | 595 | | |
| 32 | Inb'd. Bearing Lube Flow cc/min | 610 | 610 | 610 | 610 | 610 | 610 | | |
| 33 | Axial Vib. | 12.9 | 12.0 | 14.2 | 14.2 | 13.9 | 13.5 | | |

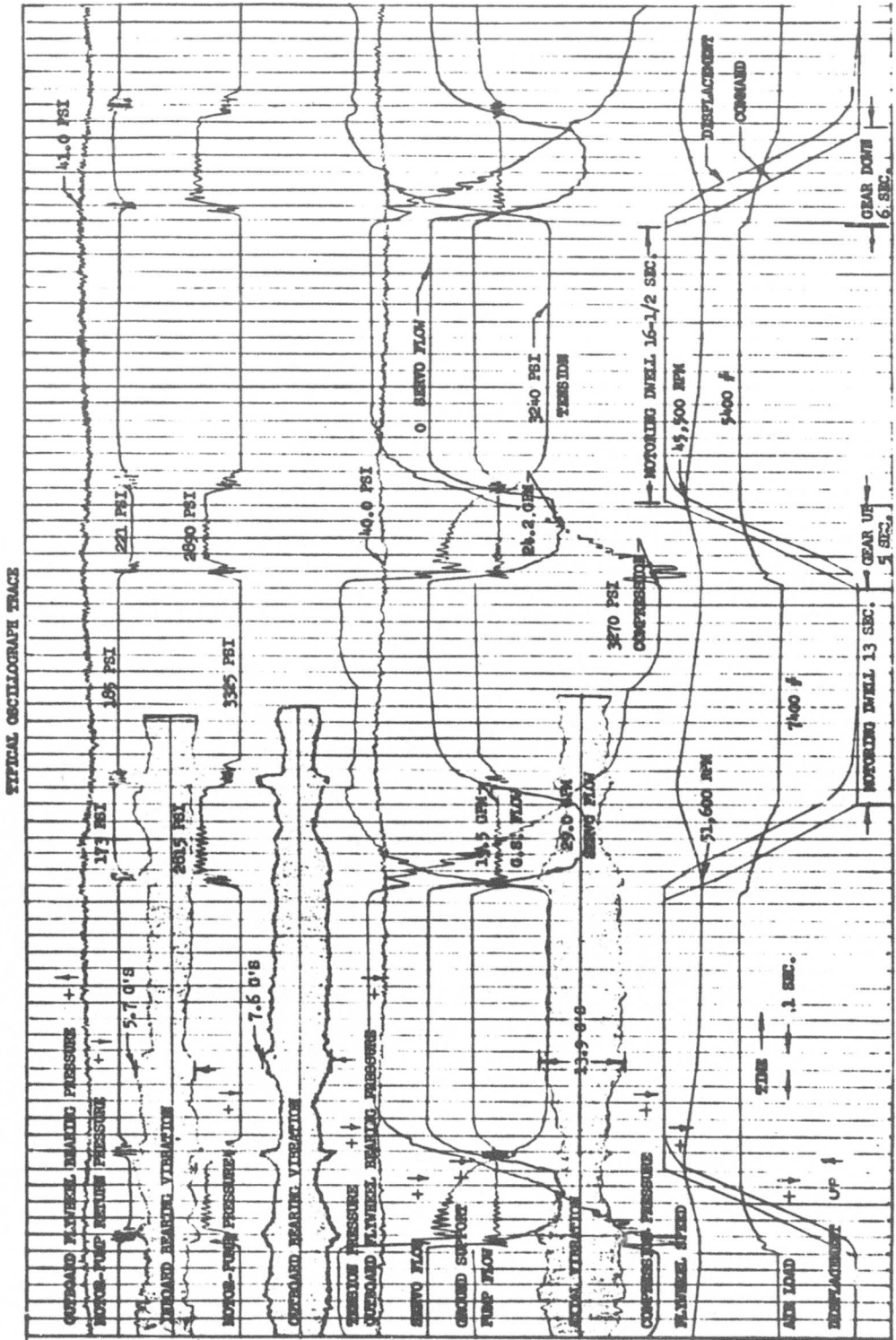

Figure 38. Landing Gear (Hydraulic) Oscillograph Record

Table XIII

INTERMITTENT DUTY CYCLE ENDURANCE TEST RESULTS SUMMARY

| | |
|---|------------------------------|
| a. Flywheel, gearbox, motor moment of inertia | .268 in.-lb sec ² |
| b. Flywheel speed at start of gear down cycle | 51,600 rpm* |
| c. Flywheel speed at end of gear down cycle | 44,600 rpm* |
| d. Flywheel speed at start of gear up cycle | 49,400 rpm* |
| e. Flywheel speed at end of gear up cycle | 45,500 rpm* |
| f. Flywheel kinetic energy reduction during gear down | 990,000 in.-lb |
| g. Flywheel kinetic energy reduction during gear up | 541,000 in.-lb |
| h. Average power supplied by flywheel during gear down | 25.0 HP |
| i. Average power supplied by flywheel during gear up | 16.4 HP |
| j. GPU flow during gear down | 19.5 gpm |
| k. Servo valve flow during gear down | 29.0 gpm |
| l. Substation flow during gear down | 9.5 gpm |
| m. Substation pressure differential during gear down | 2,642 psi |
| n. Substation hydraulic power supplied during gear down | 14.65 HP |
| o. GPU flow during gear up | 19.5 gpm |
| p. Servo valve flow during gear up | 24.2 gpm |
| q. Substation flow during gear up | 4.7 gpm |
| r. Substation pressure differential during gear up | 2,669 psi |
| s. Substation hydraulic power supplied during gear up | 7.3 HP |
| t. Efficiency of power extraction during gear down (n + h) x 100 | 58.7 percent |
| u. Efficiency of power extraction during gear up (s + i) x 100 | 44.5 percent |

* Representative speeds observed during testing

of the motor-pump as a pump, and those of the flywheel and its associated components, i.e., the gearbox, lube pump, and vacuum pump.

It is assumed that the motor-pump when operating at rated pumping conditions (i.e., 3,000 psi, 8,000 rpm and full displacement) is 85 percent efficient. On this basis the fixed losses would compute to be about a 77.5 percent efficiency in the system as it was operated during the pumping phase of the duty cycle, i.e., 9.5 gpm at 2,642 psi and speeds less than 8,000 rpm.

Based on an efficiency of 77.5 percent for the pump, the flywheel losses coupled with the lube pump, vacuum pump, and gearbox would be 6.1 horsepower in the gear-down cycle. A similar computation for the gear-up cycle shows an equivalent 5.1 horsepower loss.

These values of flywheel and associated component losses agree within normal test tolerances with the 5.0 horsepower loss determined from the Tilt Table Endurance Test.

C. MECHANICAL POWER EXTRACTION SYSTEM ENDURANCE TEST

Figures 29, 30, and 31 are applicable to the mechanical power extraction test setup for the Intermittent Duty Cycle Simulator. Additional to this, figures 39 and 40 are drawings of components unique to this arrangement.

The motor-pump used in this test arrangement was the prototype New York Airbrake type described in the section covering the Tilt Table Simulator. It was allowed to operate in the pumping mode only during shutdown of the energy storage substation. All other operation was with full displacement (.4 in. rev) as a hydraulic motor using a flow regulator on the hydraulic inlet line to limit speed.

The clutch units, figure 40, are Curtiss-Wright Part Number 164429, Federal Stock Number 1610-786-7817 used in C-133 aircraft propellers. The brake is Curtiss-Wright Part Number 161510, Federal Stock Number 1610-715-0714. The clutch, as supplied, delivered approximately 2,000 inch-pounds lockup torque with a 1,500 inch-pound engagement torque. The clutch and power hinge input shaft speed was set at 3,238 rpm which was nearly six times the speed used in the C-133 propeller application but still tended to slow gear actuation. The present XB-70 Main Landing Gear operating times are 12.5 seconds, extend, 7.5 seconds retract. To meet the 7.5 seconds time with an unmodified hinge would have required that the input gear, which was designed for 400 rpm, must turn at 8,000 rpm. In effect this would have meant that the 52,000 rpm available from the flywheel must be stepped down to 3,238 rpm in the clutches and then up to 8,000 rpm at the hinge input so that the hinge could step it down to 2 rpm. The obvious solution to this problem would have been to revise the power hinge input gearing to eliminate this "step-up". However, to do so would have involved a major revision to the power hinge and a major delay in program completion.

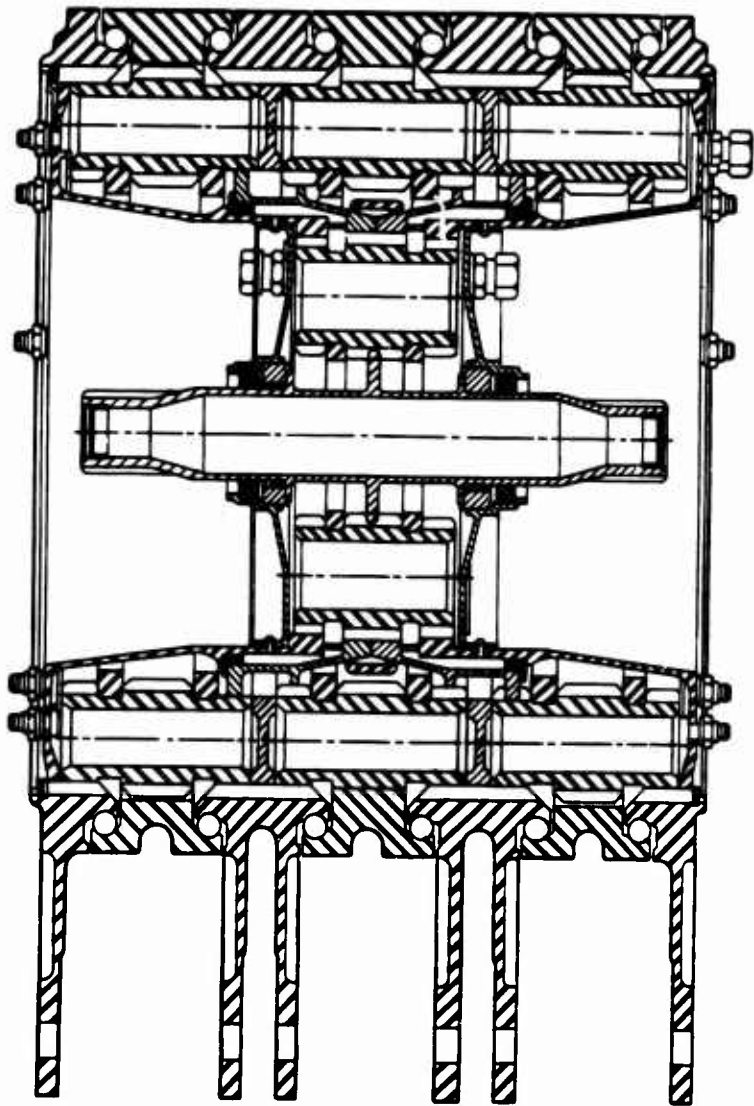

SECTION B-B

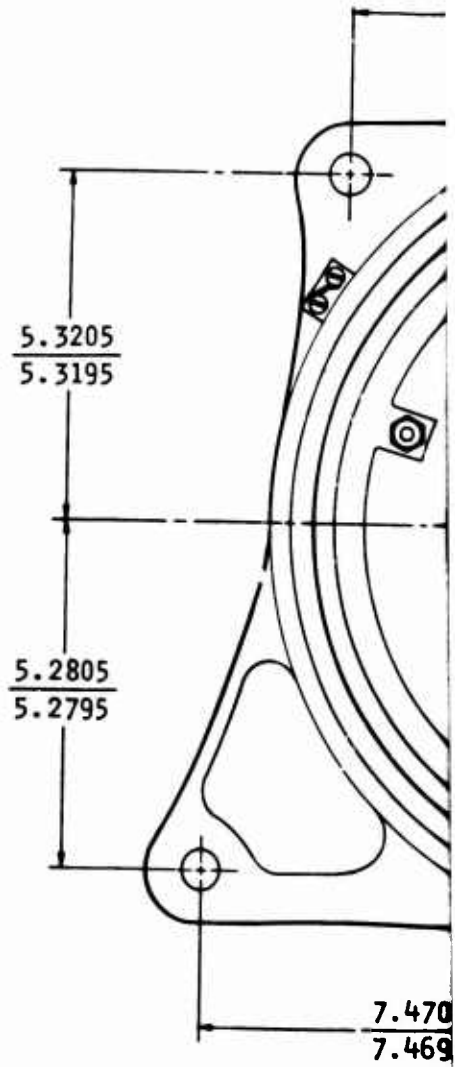

A

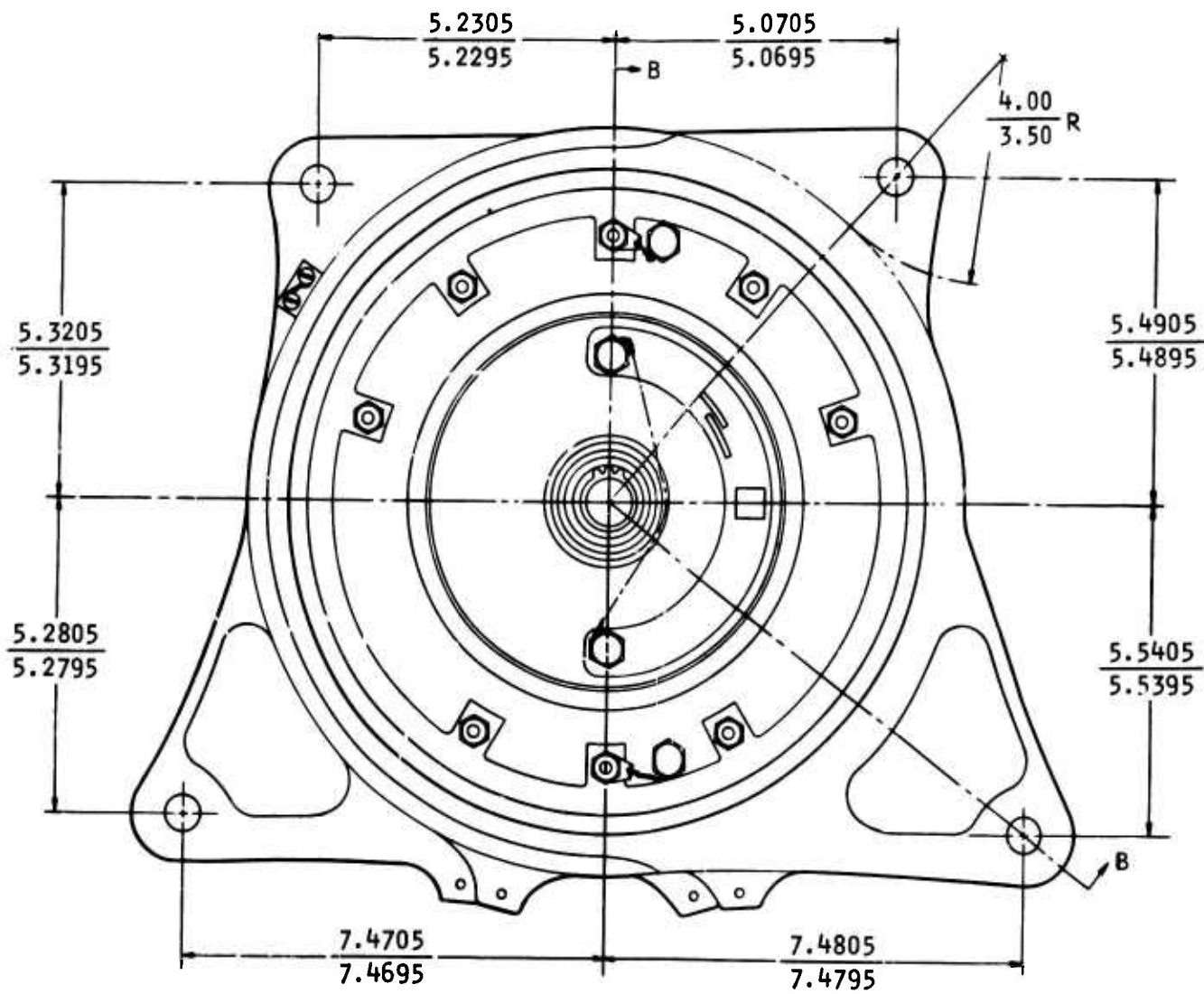
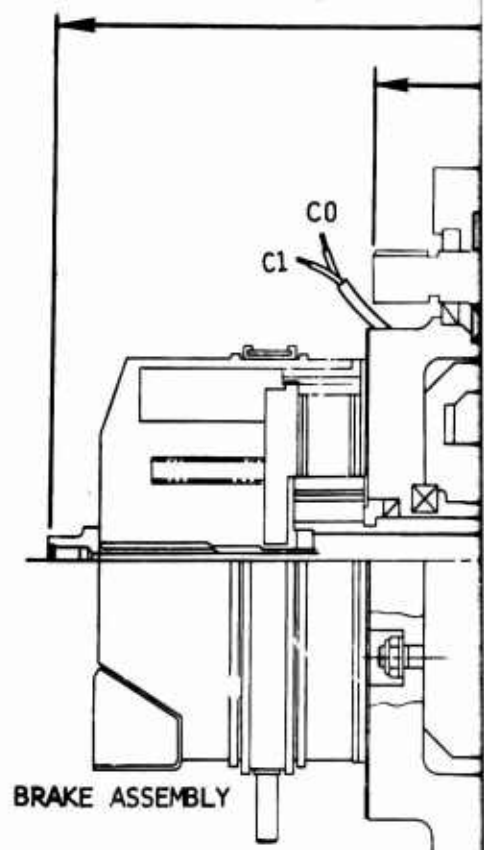
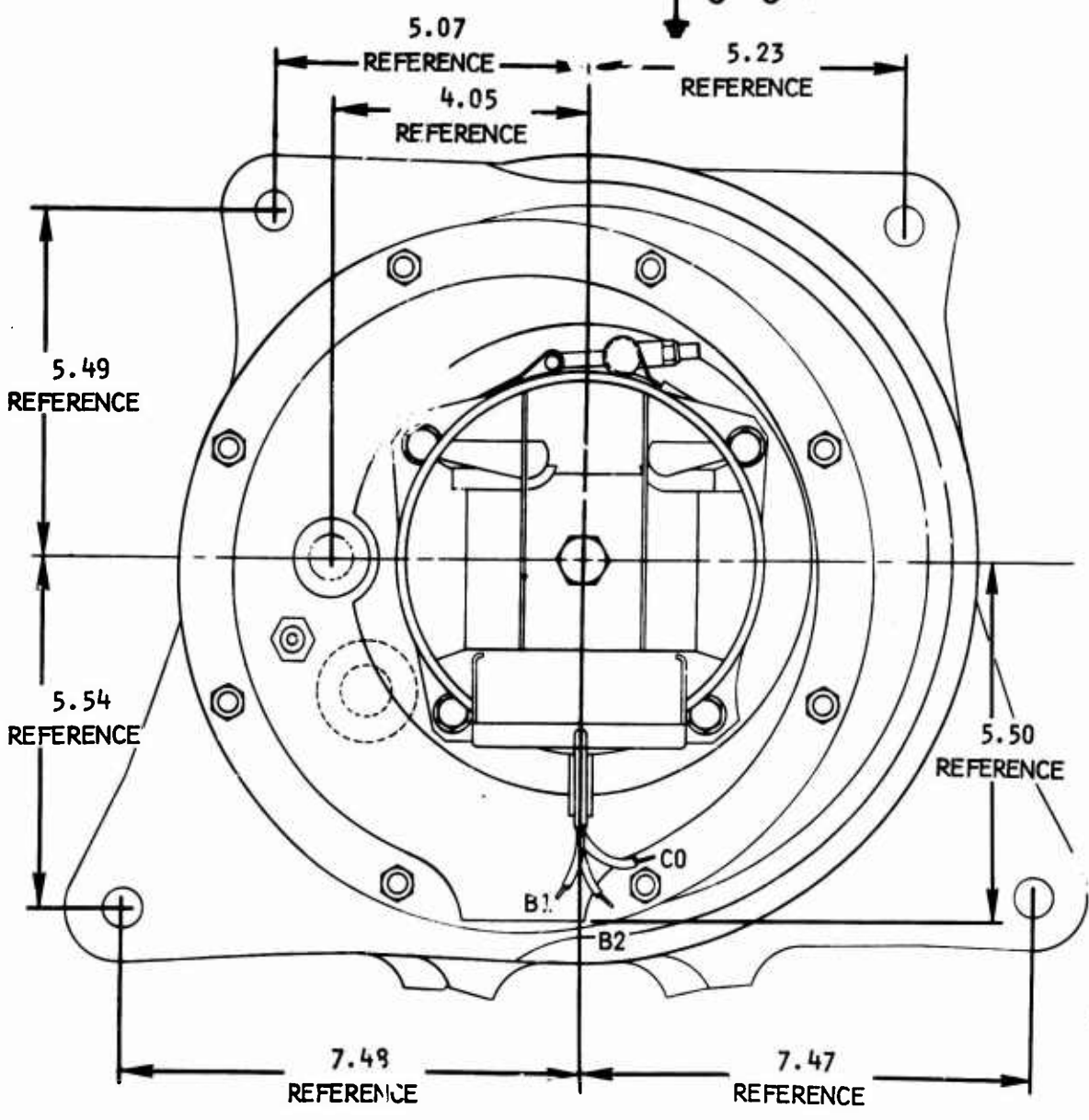
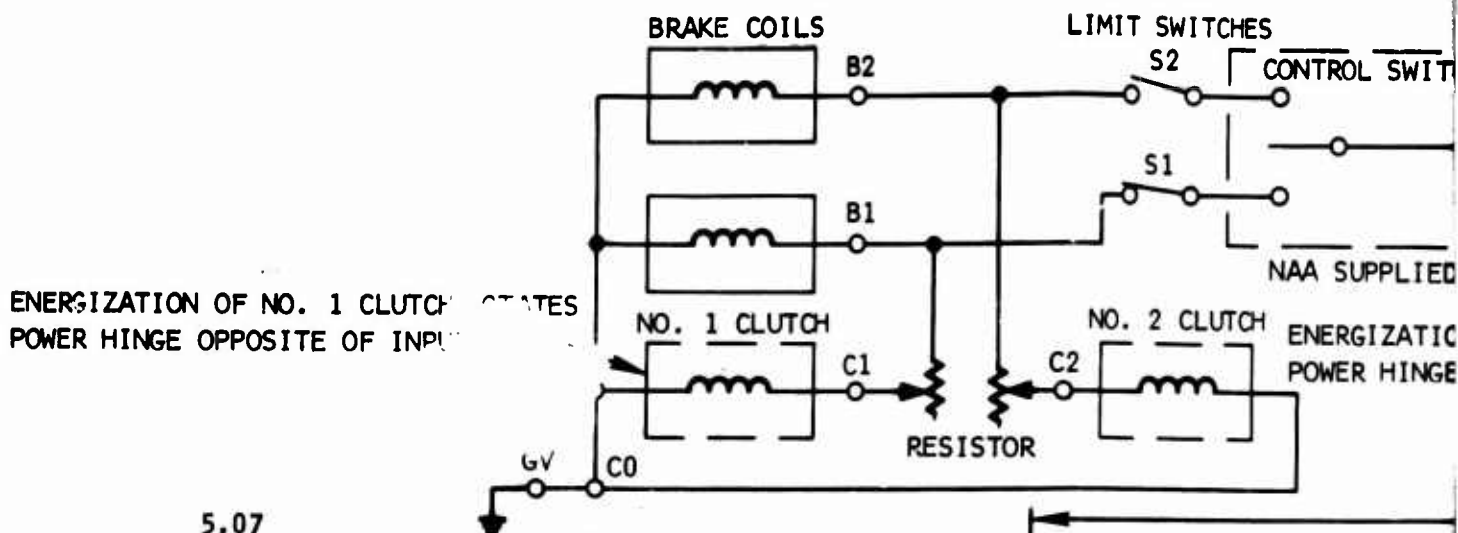

Figure 39. Mechanical Hinge

B



A

LIMIT SWITCHES

S2 CONTROL SWITCH

S1

9V+

NAA SUPPLIED

NO. 2 CLUTCH

ENERGIZATION OF NO. 2 CLUTCH ROTATES
POWER HINGE THE SAME AS INPUT SHAFT

C2

OR

C2 C0

15.185

10.1687

C0
C1

BRAKE ASSEMBLY

NO. 1
CLUTCH

NO. 2
CLUTCH

POWER HINGE ASSEMBLY

Figure 40. Clutch and Brake Assembly

B

A uniform gear extend and retract time of 15 seconds was selected. This represented a deviation from actual air vehicle duty cycles and actual air vehicle gear operation. On closer examination, however, these operating times were considered satisfactory for the following reasons:

1. Irrespective of operating time the output hinge moments remained unchanged.
2. The energy extracted from the flywheel per cycle remained essentially unchanged as a result of changed cycle time.
3. The peak torque experienced by the flywheel was a function of clutch slip-torque characteristics and was independent of operating time.
4. The peak power extraction was reduced by a factor of approximately two. However, since the fatigue stresses in the flywheel, clutch, and gearbox were primarily a function of torque and not of power, this factor did not have a significant effect on the validity of the tests.

A kinematic arrangement was chosen to connect the landing gear to the power hinge wherein the gear retracted 90 degrees while the hinge rotated 115 degrees. This is shown as figure 41. The hinge was overcenter when the landing gear was extended.

This arrangement permitted the clutches to engage with aiding loads (extend) or no-load (except inertia of the power hinge input shaft) (retract). It permitted the brake to engage with opposing load on the system (upstop) or with no-load originating from the landing gear (down-stop over-center). It was believed that this approach was very close to optimum for this landing gear configuration.

The control for this system was connected to an automatic timer wherein a switch was closed to one position and the brake and one of the two clutches was energized. This released the brake and engaged the energized clutch. At the end of the actuation stroke a limit switch would break the electric circuit, engaging the brake and disengaging the clutch. A similar sequence occurred in the reverse direction for the opposite direction of landing gear actuation.

When the endurance test was started, a total of 382 cycles were completed with no noticeable irregularities. The clutch for engaging gear-down then began to slip at the maximum load portion of the cycle and overheated to the extent that the clutch plates became warped and could not be separated from each other in the space that normally remains for the de-energized clutch plate stack. The exact cause for this failure was not immediately established, even though an extensive effort was made to analyze the details of operation associated with the test rig and test specimen.

It was noted during refurbishment that the gear-up clutch plates showed signs of overtemperature, even though this assembly was functioning properly.

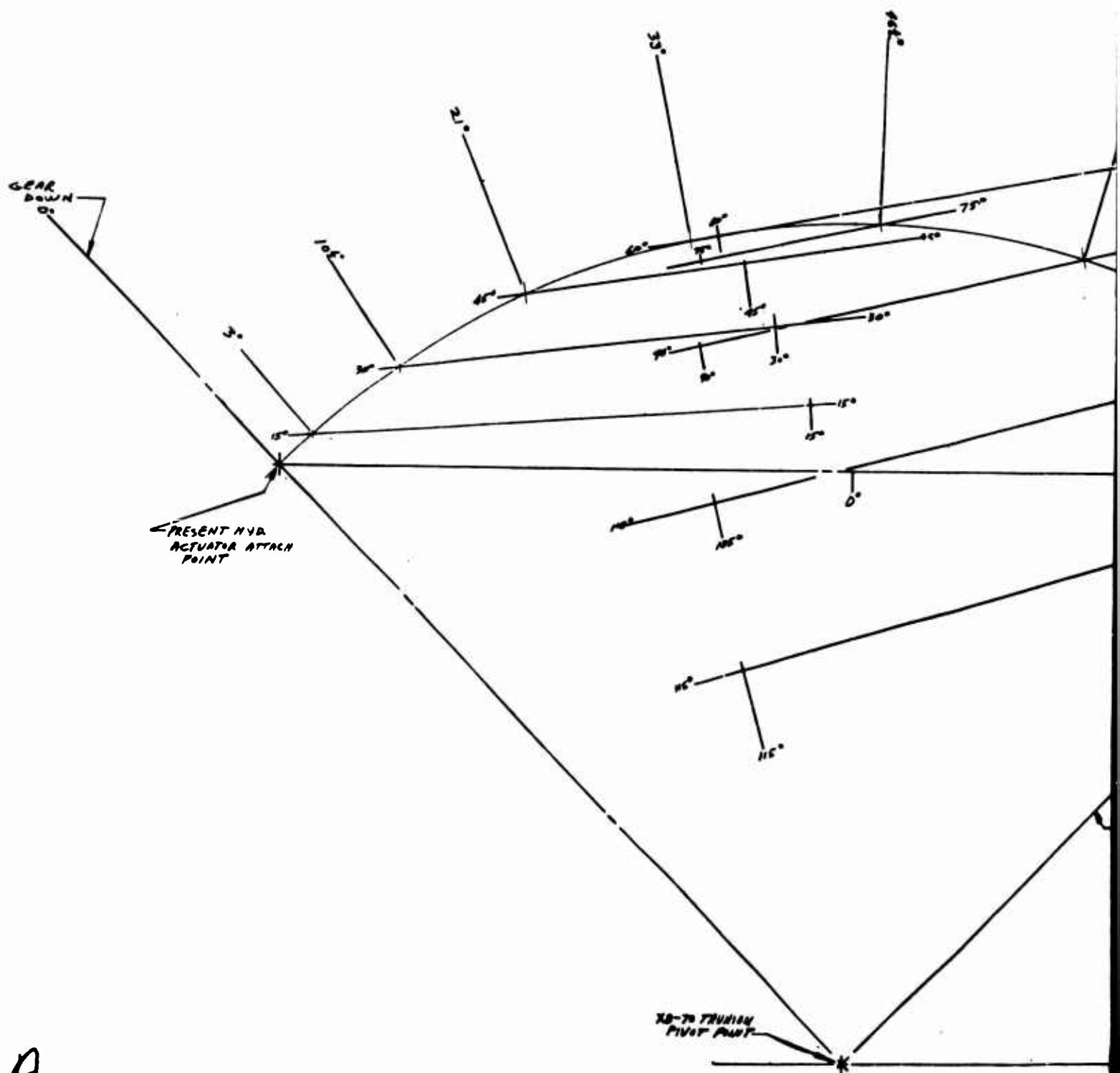

A

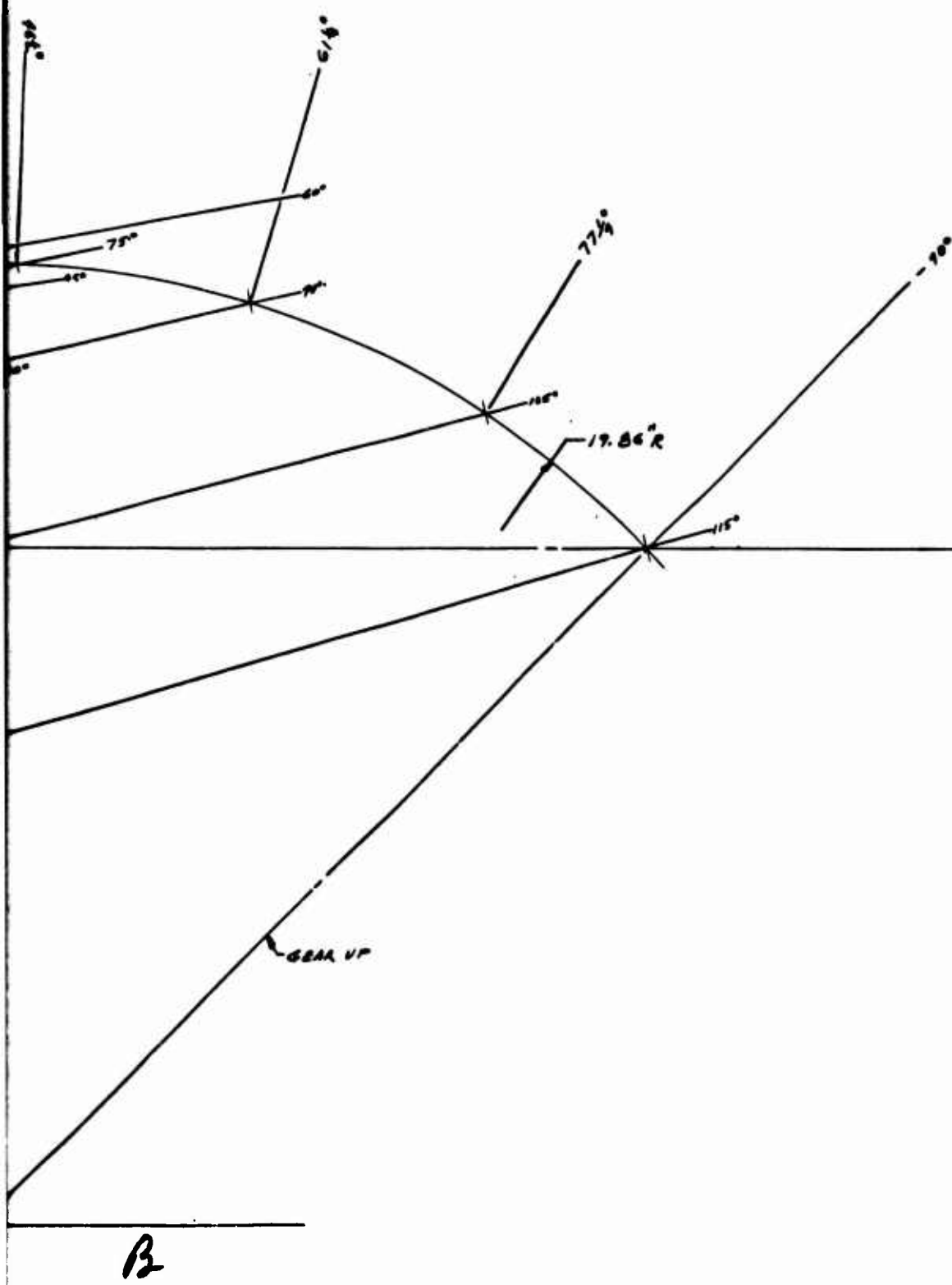

NOTE: + HINGE MOMENTS R
- HINGE MOMENTS

| LANDING GEAR ANGLE | POWER HINGE ANGLE | HINGE MOMENT |
|--------------------|-------------------|--------------|
| 0° | 0° | 7.0 |
| 3° | 15° | 7.8 |
| 10 1/2° | 30° | 8.7 |
| 21° | 45° | 9.5 |
| 33° | 60° | 9.95 |
| 46 1/2° | 75° | 9.6 |
| 61 1/2° | 90° | 8.7 |
| 77 1/2° | 105° | 6.8 |
| 90° | 115° | 1.8 |
| 97 1/2° | 120° | — |

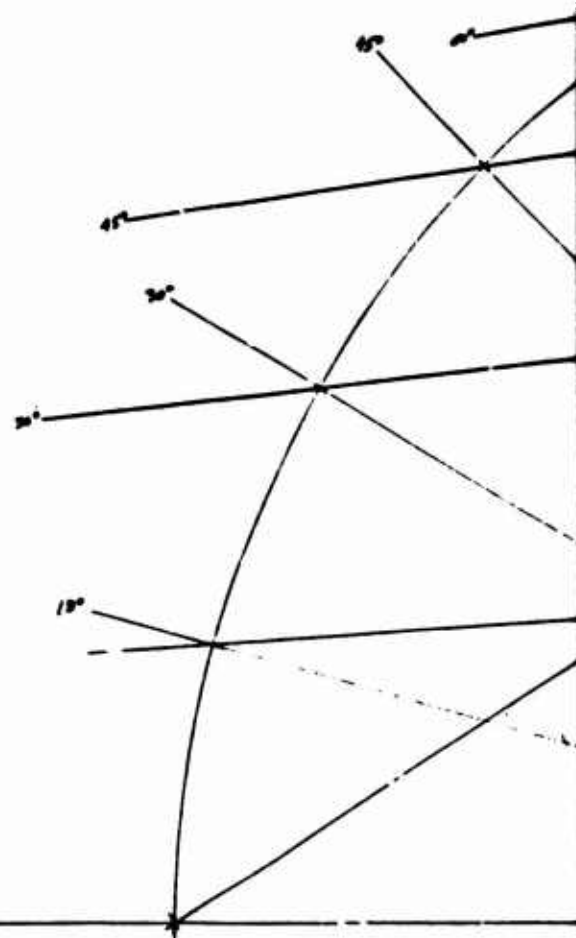

NOTE: + HINGE MOMENTS RESIST MOTION
 - HINGE MOMENTS AID MOTION

| LANDING GEAR ANGLE | POWER HINGE ANGLE | LANDING GEAR LEVER ARM | POWER HINGE LEVER ARM | LANDING GEAR HINGE MOMENT RETRACTING | LANDING GEAR HINGE MOMENT EXTENDING | LEVER ARM RATIO (POWER HINGE / LANDING GEAR) | POWER HINGE HINGE MOMENT RETRACTING | POWER HINGE HINGE MOMENT EXTENDING |
|--------------------|-------------------|------------------------|-----------------------|--------------------------------------|-------------------------------------|--|-------------------------------------|------------------------------------|
| 0° | 0° | 7.00 | 0.0 | -1,083,259 | +939,000 | $\frac{0.0}{7.0} = 0$ | 0 | 0 |
| 3° | 15° | 7.82 | 2.93 | -965,000 | +729,000 | $\frac{2.93}{7.82} = .375$ | -362,000 IN-LB | +345,000 IN-LB |
| 10½° | 30° | 8.78 | 5.37 | -900,000 | +875,000 | $\frac{5.37}{8.78} = .611$ | -550,000 IN-LB | +535,000 IN-LB |
| 21° | 45° | 9.57 | 7.27 | -805,000 | +820,000 | $\frac{7.27}{9.57} = .760$ | -611,000 IN-LB | +623,000 IN-LB |
| 33° | 60° | 9.95 | 8.48 | -700,000 | +725,000 | $\frac{8.48}{9.95} = .853$ | -597,000 IN-LB | +618,000 IN-LB |
| 46½° | 75° | 9.69 | 9.05 | -480,000 | +500,000 | $\frac{9.05}{9.69} = .935$ | -449,000 IN-LB | +467,000 IN-LB |
| 61½° | 90° | 8.70 | 8.85 | -49,000 | +75,000 | $\frac{8.85}{8.70} = 1.02$ | -49,800 IN-LB | +76,500 IN-LB |
| 77½° | 105° | 6.85 | 7.93 | +375,000 | -340,000 | $\frac{7.93}{6.85} = 1.16$ | +435,000 IN-LB | -379,000 IN-LB |
| 90° | 115° | 4.89 | 6.83 | +513,000 | -430,000 | $\frac{6.83}{4.89} = 1.41$ | +723,000 IN-LB | -606,000 IN-LB |
| 97½° | 120° | — | — | — | — | — | — | — |

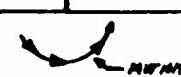

c

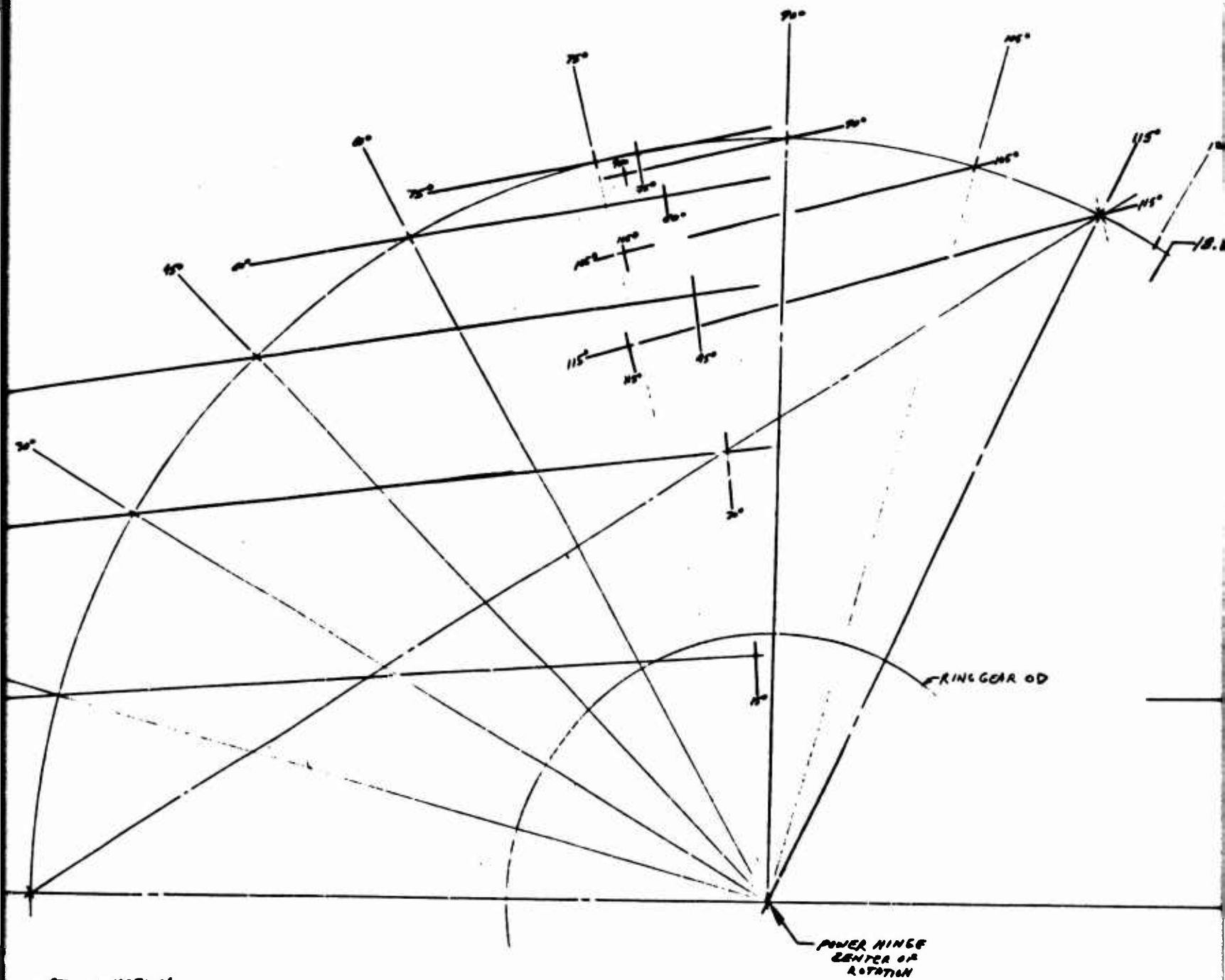

| HINGE RAYS | POWER HINGE MOMENT EXTENS |
|---------------|------------------------------|
| | 0 |
| W-LB | +345,000 IN-LB |
| IN-LB | +535,000 IN-LB |
| N-LB | +623,000 W-LB |
| W-LB | +618,000 IN-LB |
| IN-LB | +467,000 IN-LB |
| IN-LB | +76,500 IN-LB |
| IN-LB | -379,000 IN-LB |
| IN-LB | -606,000 IN-LB |

D

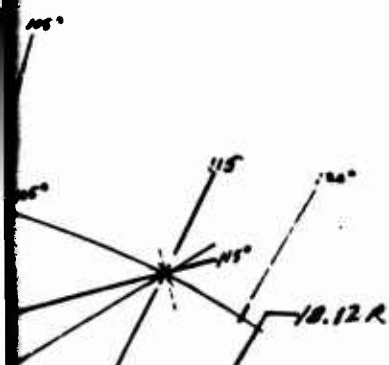

EXTRACTING WORK FROM FLYWHEEL

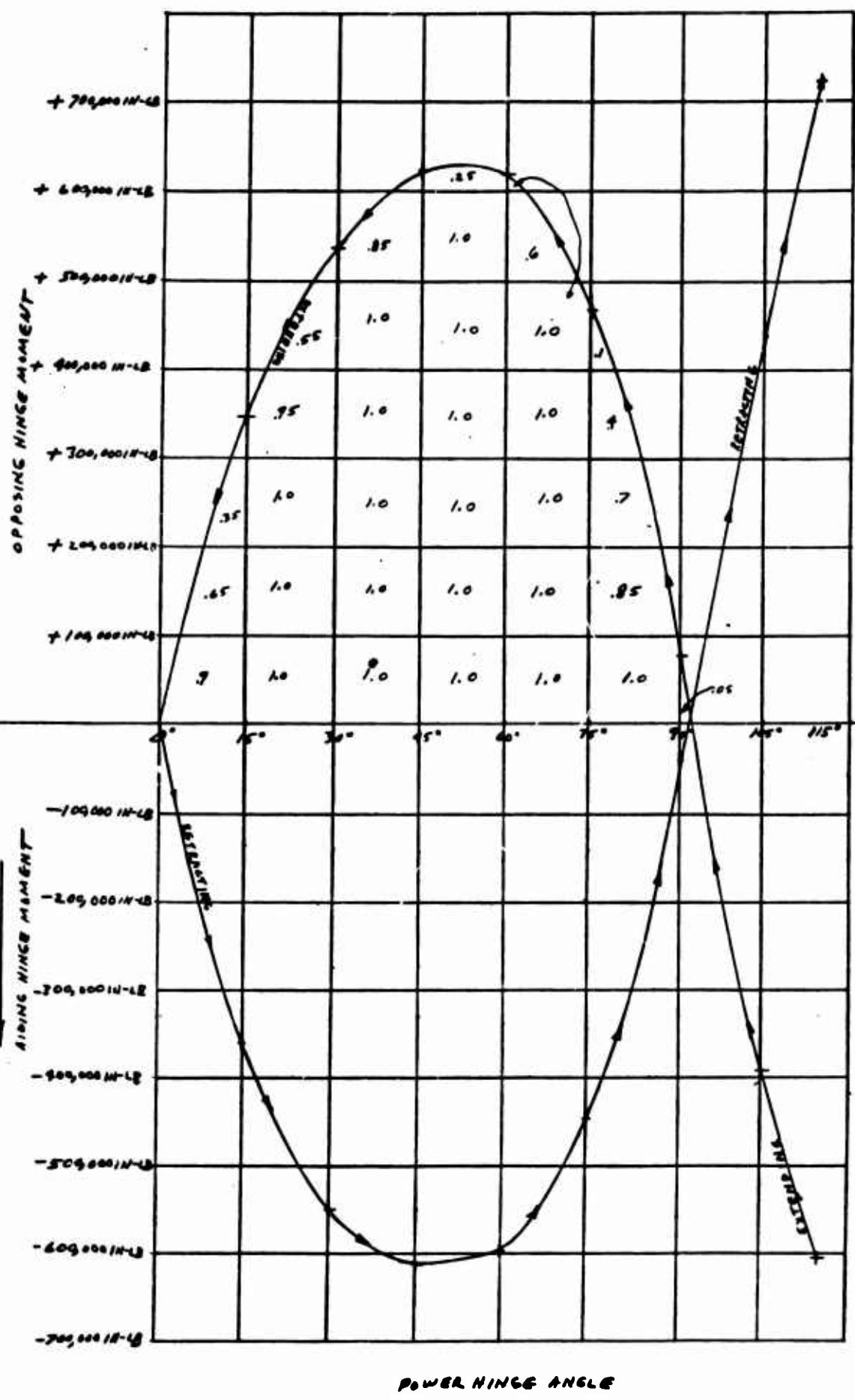

Figure 41. Landing Gear Kinematics

E

A number of potential causes, which were considered, were as follows:

1. Interruption of the clutch lubrication and cooling oil supply
2. Inadvertent energization of the gear-up clutch during the gear-down cycle
3. Inadvertent de-energization of the brake during the gear-down cycle
4. Overload of the clutch by improper operation of the simulated airload system, or by binding in the bearings which attach the linkages to the strut
5. Inadvertent partial de-energization of the gear-down clutch during the gear-down cycle

Following completion of the refurbishment of the clutches, the unit was reinstalled on the simulator. All systems and equipment were checked for proper operation, and endurance testing was resumed.

On the maximum load portion of the second gear-down cycle a repeat of the first failure occurred. In this case the clutch bindup was sufficient to bring the flywheel to zero rpm in about 5 seconds.

The unit was removed and was again returned to the supplier. Disassembly and inspection revealed that the gear-down clutch had done some slipping and showed signs of overtemperature. However, the location of the principal drag loss, where maximum heating occurred and where the flywheel energy must have been consumed with such rapidity, was in the gear-up clutch plates. With this in mind, and remembering that the relative slipping speed of the de-energized clutch doubles during a gear-up or gear-down operation, two additional causes for failure were advanced as possibilities.

1. Improper proportioning, distribution or inadequate quantity of cooling oil supply to the clutches
2. Improper configuration of the clutch plate stack with respect to diametral size, rotational speed, quantity of plates, and space between plates while operating in a de-energized condition

The assembly was completely refurbished and modifications made to increase the space between plates as much as possible within the confines of the existing envelope as well as modifications to direct and more evenly distribute a larger amount of the cooling oil to the plates. These changes were deemed prudent since as has already been pointed out, this application of the clutch calls for speeds several times that for which it was originally designed. Any additional changes of still larger scope which might have been necessary to correct the problem, such as a reduction of the clutch plate diameter, or a change in the clutch speed, through gearing revisions, were not considered possible within the effort and schedule limits of the program.

The assembly was then reinstalled on the simulator and the test again resumed. Performance was satisfactory; however, as the test progressed it was noted that the dwell time between cycles needed to be extended to permit the flywheel to regain its upper operating speed. Additionally the hydraulic supply pressure to the motor had to be progressively increased. Degradation was also noted with respect to an increase in the speed reduction experienced during the gear-down cycle.

After reaching a point somewhere in excess of 1,650 cycles a slipping of the gear-down clutch began to occur intermittently during the heaviest load portion of the stroke. When this occurred, it became standard procedure for the operator to stop the actuation and reverse the stroke. The opposing airloads then became aiding airloads and the gear could be retracted. After this reversal, normal cycles could be operated. However, as would be expected, the frequency of occurrence of this slipping increased, and eventually required shutdown of the simulator at 1,745 cycles.

After a review of the problems, the corrective action previously taken, and test data accumulated to date, it was apparent that a major redesign would be necessary to accomplish the original number of test cycles without an extensive number of refurbishments; therefore, testing was terminated.

The test did, however, accomplish the basic objective of demonstrating the mechanical power extraction approach for energy storage substations, even though the components were misconfigured for this application. Additional testing would have served no useful purpose other than to show 10,000 cycles could be attained after repeated refurbishment of this hardware, where in reality a proper design would require components especially constructed for this application.

Data from this test are shown in table XIV. Figure 42 is a data record taken near the end of the test.

From the data, table XV was created to summarize the performance. The efficiency of 18.7 percent for the mechanical system during gear-down would, on the surface, seem unattractively low; however, this number represents the inefficiency of all of the elements in series, from the flywheel to the airload cable in one path, and from the hydraulic motor to the airload cable in another path. A breakdown of the various elements in these paths is not possible because there were no dynamic torque measurements recorded.

A similar figure in the hydraulic power extraction system would use 25 horsepower as flywheel input, 30 horsepower as GPU input resulting in a total of 2,180,000 inch-pounds over a 6-second time span. This would represent 32.7 percent efficiency including all of the elements in the load path to the airload cable.

Before the test, it was believed that the mechanical system would show a much higher efficiency than the hydraulic power extraction system. The reason that it did not is principally because of the no-load losses that

Table XIV

**INTERMITTENT DUTY CYCLE SIMULATOR TEST DATA
(MECHANICAL POWER EXTRACTION)**

Summary Data Sheet No.

| DURN | | 7-31 | 8-1 | 14-30 | 2-4 | 2-6 | 2-7 | 2-7 | |
|--|--------------------------------------|-----------|---------|---------|---------|---------|---------|---------|---------|
| Accum. Running Time of Test - Hours | | 127.5 | 131.1 | 136.5 | 144.4 | 150.6 | 156.4 | 162.3 | |
| Total Operation Load Cycles | | 50 | 200 | 500 | 750 | 1000 | 1250 | 1500 | |
| Vibration Am. at Flywheel Bearings g's | Inboard | - | 2.8 | 8.1 | 8.1 | - | - | - | |
| | Outboard | 2.1 | 11.7 | 7.2 | 13.6 | 13.6 | 12.0 | 8.4 | |
| | Axial | 15.8 | 16.7 | 14.2 | 16.8 | 15.5 | 14.5 | 15.5 | |
| Flywheel Speed at Full Motoring - RPM | | 49,600 | 49,000 | 51,000 | 49,000 | 52,400 | 49,500 | 49,400 | |
| Minimum Speed Attain Under Load - RPM | | 37,200 | 38,800 | 45,000 | 37,800 | 35,700 | 37,700 | 37,000 | |
| Average Operational Time Sec./Cycle | Gear Up | 20 | 18 | 15 | 15 | 16 | 15 | 15 | |
| | Gear Down | 20 | 16 | 17 | 15 | 18 | 18 | 18 | |
| Dwell Time - Seconds | Gear Up | 25 | 32 | 17 | 17 | 15 | 15 | 16 | |
| | Gear Down | 25 | 40 | 30 | 33 | 32 | 30 | 31 | |
| Air Load on Gear - lbs. | Gear Up | 5280 | 5560 | 5740 | 5170 | 5500 | 5660 | 5340 | |
| | Gear Down | 6795 | 6780 | 7490 | 6840 | 7240 | 7510 | 7000 | |
| Push-Pull Arm Load - Total | | Gear Up | 56,600 | 56,800 | 60,000 | 61,300 | 63,200 | 62,600 | 63,000 |
| Push-Pull Arm Load - Total | | Gear Down | -65,300 | -60,300 | -70,600 | -66,400 | -67,800 | -73,000 | -64,600 |
| NO. TEMPERATURE DATA - DEG. F | | | | | | | | | |
| 1 | Test Motor - Pump Inlet Temp. | 92 | 105 | 110 | 95 | 99 | 100 | 100 | |
| 2 | Test Motor - Pump Return Temp. | 102 | 107 | 107 | 93 | 95 | 97 | 96 | |
| 3 | Test Motor - Pump Case Drain Temp. | 120 | 137 | 160 | 146 | 150 | 154 | 153 | |
| 4 | Main Hyd. Reservoir Supply Temp. | 100 | 108 | 105 | 99 | 100 | 101 | 100 | |
| 5 | Gear Box Lube Oil Return Temp. | 103 | 108 | 210 | 173 | 172 | 183 | 173 | |
| 6 | Gear Box Lube Oil Suction Temp. | 75 | 76 | 83 | 65 | 66 | 70 | 63 | |
| 7 | Gear Box Scavenger Oil Return Temp. | 122 | 160 | 168 | 142 | 149 | 163 | 156 | |
| 8 | Gear Box Brg. Adj. Pump Temp. | 137 | 165 | 172 | 162 | 170 | 172 | 173 | |
| 9 | Gear Box Brg. Adj. Flywheel Temp. | 142 | 175 | 186 | 158 | 168 | 179 | 174 | |
| 10 | Inboard Flywheel Bearing Temp. | 152 | 185 | 170 | 136 | 145 | 156 | 150 | |
| 11 | Outboard Flywheel Bearing Temp. | 153 | 182 | 190 | 155 | 155 | 162 | 154 | |
| 12 | Flywheel Case Housing Temp. | 153 | 173 | 158 | 90 | 90 | 114 | 95 | |
| 13 | Lube Oil to Clutch - Brake Temp. | - | 70 | 110 | 108 | 105 | 110 | 108 | |
| 14 | Lube Oil from Clutch - Brake Temp. | - | 105 | 120 | 115 | 110 | 118 | 110 | |
| 15 | L.H. Side Cover Hinge Temp. | 250 | 175 | - | - | - | - | - | |
| 16 | R.H. Side Cover Hinge Temp. | 230 | 165 | 170 | 160 | 180 | 188 | 200 | |
| 16a | Lube Oil from Brake Temp. | - | 105 | 90 | 85 | 90 | 125 | 159 | |
| NO. SYSTEM PRESSURE DATA - PSIG | | | | | | | | | |
| 17 | Outboard Flywheel Bearing Press. | 39.0 | 43.4 | 40.4 | 28.2 | 27.4 | 26.7 | 25.2 | |
| 18 | Inboard Flywheel Bearing Press. | 39.0 | 43.1 | 40.5 | 26.3 | 26.7 | 27.7 | 26.3 | |
| 19 | Lube Pump Pressure Port Press. | 50 | 50 | 50 | 48 | 48 | 40 | 48 | |
| 20 | Lube Reservoir Press. | 0 | 0 | 0 | 0 | 0 | 0 | 0 | |
| 21 | Hyd. Supply Pump Press. at Source | 2960 | 3100 | 3300 | 3335 | 3400 | 3420 | 3440 | |
| 22 | Test Motor - Pump Port Press. | 2950 | 2975 | 3250 | 3230 | 3350 | 3350 | 3350 | |
| 23 | Pressure (Motoring) Return | 168.0 | 168.0 | 164.5 | 164.5 | 164.5 | 170 | 170 | |
| 24 | Test Motor - Pump Case Drain Press. | 166 | 168 | 168 | 167 | 167 | 165 | 166 | |
| 25 | Press. at Flywheel Tip - On Hg Ab | 3.0 | 3.0 | 2.5 | 1.5 | 1.9 | 2.2 | 2.4 | |
| 26 | Lube Press to Clutch | 26 | 25 | - | 34.0 | 32.0 | 32.5 | 32.0 | |
| NO. FLUID FLOW DATA | | | | | | | | | |
| 27 | Hyd. Supply Pump Flow - GPM | 16 | 16.1 | 16 | 16 | 16 | 16 | 17 | |
| 28 | Lube Flow - GPM | - | 3.5 | 3.5 | 5.0 | 5.1 | 5.1 | 5.0 | |
| 29 | Case Drain of Motor - GPM | - | 1.1 | 1.5 | 1.5 | 1.50 | 1.47 | 1.48 | |
| 30 | Out'd. Bearing Lube - Flow cc/min. | 545 | 580 | 555 | 631 | 670 | 655 | 640 | |
| 31 | In'd. Bearing Lube - Flow cc/min. | 560 | 590 | 570 | 705 | 715 | 730 | 705 | |
| NO. POWER SUPPLY | | | | | | | | | |
| 32 | Clutch Power Supply - Voltage - Down | | | 12.5 | | 11.0V | 11.0V | 12.7V | |
| 33 | Clutch Power Supply - Voltage - Up | | | 12.0 | | 12.5V | 12.5V | 12.4V | |
| 34 | Clutch Power Supply - Amp - Down | | | 8.5 | | 8.9A | 8.8A | 8.8A | |
| 35 | Clutch Power Supply - Amp - Up | | | 10.5 | | 11.0A | 11.0A | 10.5A | |

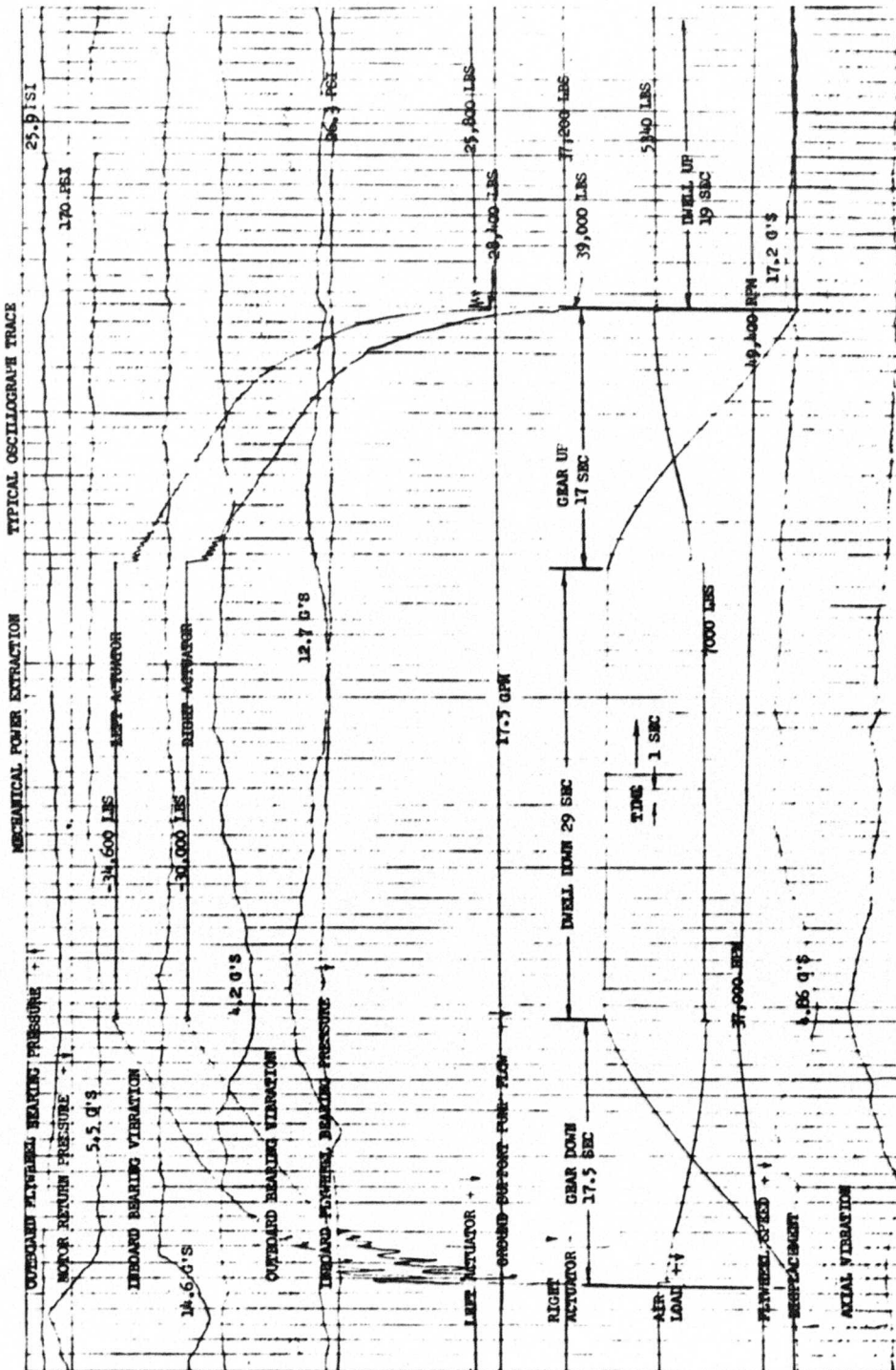

Figure 42. Landing Gear (Mechanical) Oscillograph Record

Table XV

MECHANICAL POWER EXTRACTION ENDURANCE TEST RESULTS SUMMARY

| | |
|---|------------------------------|
| a. Flywheel, etc, moment of inertia | .268 in.-lb sec ² |
| *b. Flywheel speed at start of gear-down cycle | 49,600 rpm |
| *c. Flywheel speed at end of gear-down cycle | 39,200 rpm |
| d. Flywheel kinetic energy reduction during gear-down | 1,365,000 in.-lb |
| e. Average power supplied by flywheel during gear-down | 11.7 HP |
| f. Hydraulic motor pressure differential | 2,680 psi |
| g. Hydraulic motor flow | 10.0 gpm |
| h. Kinetic energy supplied by hydraulic motor during gear-down (85 percent eff) | 1,815,000 in.-lb |
| i. Average power supplied by hydraulic motor during gear-down | 21.2 HP |
| j. Total kinetic energy supplied to mechanical system during gear-down | 3,180,000 in.-lb |
| k. Total average power supplied to mechanical system during gear-down | 32.9 |
| l. Theoretical mechanical energy required by airload and weight | 712,042 in.-lb |
| m. Theoretical average mechanical power required by airload and weight | 5.4 HP |
| n. Efficiency of mechanical system during gear-down | 22.4 percent |

* NOTE The net flywheel speed change during gear-up was frequently equal to zero resulting in no change to the flywheel kinetic energy.

existed in the deenergized clutch. This first became apparent when substation operational checkout required an unusually long time to bring the flywheel up to speed. As noted in the endurance test description, these losses were the result of improper clutch configuration for this application, and eventually lead to early termination of the test.

The flywheel both speeded up and slowed down during the gear-up portion of the cycle; however, in general the net change in speed was for all practical purposes equal to zero. Considering the inefficiencies just cited in the mechanical system, this characteristic of the simulator would indicate that a large amount of the aiding load power was being constructively used to offset losses. It is conceivable that in a properly configured system, the aiding loads of a duty cycle could be used to help restore flywheel speed. This consideration is not applicable in the hydraulic power extraction system.

D. INTERMITTENT DUTY CYCLE SIMULATOR TEST CONCLUSIONS

The tests conducted on the Intermittent Duty Cycle Simulator indicated that mechanical power extraction employing disc clutches and mechanical hinges is very feasible. However, the tests also indicated that, wherever a high inertia power source (such as the flywheel) is connected to, and operates, a high inertia load (such as the landing gear) by means of a clutch, the starting (acceleration) and stopping (deceleration) of the load should be accomplished through overcenter linkage or its equivalent.

As has been previously indicated it was also concluded from these tests that the selection of the clutch size and operating speed is a major factor in the effectiveness of this approach. For this particular application it was concluded that the clutch brake unit should have operated at approximately one-half the speed necessitated by this application (i.e., 1,600 rpm versus this application's 3,238 rpm) and the mechanical hinge's gear reduction ratio should have been reduced to one-third of its present value (i.e., 830:1 versus this application's 2,500:1).

The incorporation of all of these changes (i.e., overcenter linkage, reduced clutch speed and reduced hinge ratio) should lead to numerous improvements in the system as follows:

1. Parasite losses should reduce by 50 percent. This would mean that item k in table XV would become $19.25[33.3 \text{ HP} - (33.3 - 6.2).50 = 19.25]$, thus improving the efficiency of item n to 32 percent. It should be noted that this efficiency is nearly a standoff with the equivalent hydraulic system efficiency (32.7 percent) mentioned earlier. However, since the hydraulic system's efficiency is essentially the same for gear-up and gear-down while the mechanical system can take advantage of aiding loads and does not extract energy from the flywheel during gear-up, it may be safely concluded that the mechanical system's cycle efficiency in terms of losses is approximately twice as good as that of the hydraulic system.

2. Heat rejection, which was a problem throughout the mechanical demonstration, would be reduced by 50 percent and would cease to be a significant consideration.
3. Gear cycle time would be comparable to that exhibited by the hydraulic type (i.e., less than 12.5 seconds).
4. Mechanical power extraction component weight would be reduced and would total to about 250 pounds. The weight of the system as tested was 299 pounds and consisted of the following component weights:

| | |
|-------------------|---------------------|
| Clutch brake unit | 102.5 pounds |
| Mechanical hinge | 199.5 pounds |
| PTO shaft | 2.0 pounds |
| Total | <u>299.0</u> pounds |

With overcenter linkage the size of the brake could be greatly reduced. This plus refinements in the clutches and gearing should make possible a 33-pound weight reduction in the clutch brake unit. The reduction in mechanical hinge gearing ratio would make possible the revision of the inner stage gearing which in turn would reduce the hinge weight by about 16 pounds.

The tabulated weight data for the system would then become:

| | |
|-------------------|---------------------|
| Clutch brake unit | 69.5 pounds |
| Mechanical hinge | 178.5 pounds |
| PTO shaft | 2.0 pounds |
| Total | <u>250.0</u> pounds |

It was concluded when comparing mechanical versus hydraulic power extraction that each had certain basic characteristics which, under a given set of circumstances, might favor its use. The hydraulic system has high efficiency under high load but low efficiency under low load, and no load losses are about as large as the useful work accomplished during peak load. As previously stated, the hydraulic system cannot take advantage of aiding loads. In the presence of aiding loads the flywheel still loses speed. On the other hand, the mechanical systems can store energy in the presence of aiding loads but suffers relatively high energy extraction rates from the flywheel during opposing load portions of the cycle. From this it was concluded that, where load conditions were the primary factor considered, hydraulic systems would tend to be favored in the presence of sustained high opposing loads whereas mechanical systems would be preferred in the presence of moderate average loads and/or reversing loads.

It was also concluded that the mechanical system is inherently more flexible in application. By definition the means for energy input and extraction in the hydraulic system is limited to hydraulic devices (i.e., pumps, motors, and/or pump-motors). Conversely the mechanical system, although limited to mechanical devices for energy extraction, is adaptable to a variety of input devices. These would include hydraulic motors, electric motors, shafting, and gas turbines.

Section V

CONTINUOUS DUTY CYCLE SIMULATOR

A. FLIGHT CONTROL APPLICATION

The Continuous Duty Cycle Simulator was a test arrangement of a simulated flight control system that demonstrated an application of a flywheel energy storage substation. Flight control functions are typified by an almost continuous demand for power at low level (usually below 10 percent of maximum rated power) interspersed with short term power demands approaching 100 percent rated power. The substation in this application was designed to supply a third of the power requirement when the 100 percent rated demand was called for by the duty cycle. On an actual airplane, this would allow the normal engine-driven secondary power system to be designed to slightly larger than continuous duty cycle requirement. Specifically, this simulator was designed to demonstrate the ability of an energy storage substation to supply power to a load bank which simulated the duty cycle and power requirement equivalent to a single system operation of three panels of the XB-70 elevon system.

B. SIMULATOR

As shown in figure 43, the simulator consisted of a laboratory hydraulic power supply package, a motor-pump hydraulic unit, a gearbox for exchanging energy between the motor-pump and flywheel, a flywheel together with its housing, and a load bank package. The XB-70 elevon panel actuator package was simulated by a linear actuator with equal extending and retracting piston areas which converted flow into linear motion. The actuator operated a linear potentiometer which supplied information for the data record.

The energy storage substation for the simulator used the automatic New York Airbrake type motor-pump which incorporated the integrated pressure sensing for motoring and pumping modes, and for varying pumping displacement. A description of the function of the control is covered in the section pertaining to the Tilt Table Simulator.

Fabrication of the Simulator consisted essentially of conversion of the Tilt Table Simulator into a test arrangement with a fixed (nontilting) mounting and the rearrangement and addition of the equipment to impose the appropriate flight control duty cycle power extraction on the energy storage substation.

The flight control duty cycle flow demand was plotted as a curve on a rotating (Data-Trak) drum, which had a curve-following device that generated a representative signal. This signal was supplied to a Moog servo valve which imposed the flow demands on the energy storage substation by operating the actuator.

The duty cycle created for this 1,500-hour endurance test is shown in figure 44. It describes flow characteristics for a simplified yet representative set of motions for operation of three elevon panels in the XB-70 flight control system. The flow pattern shown (covering an interval of

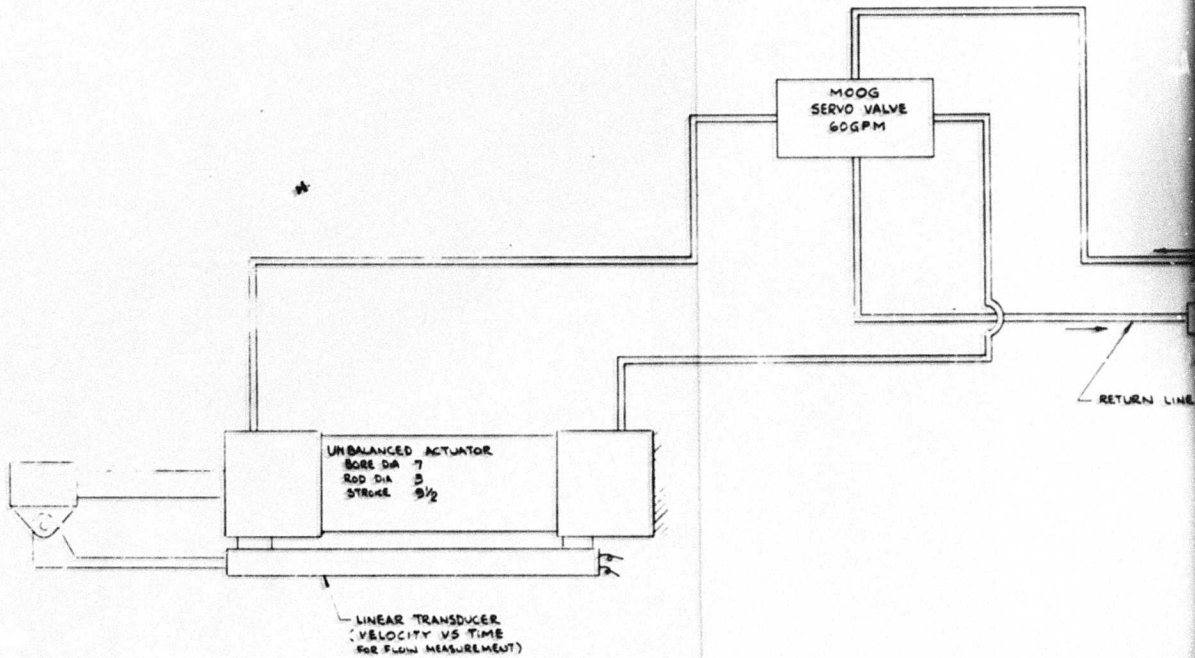
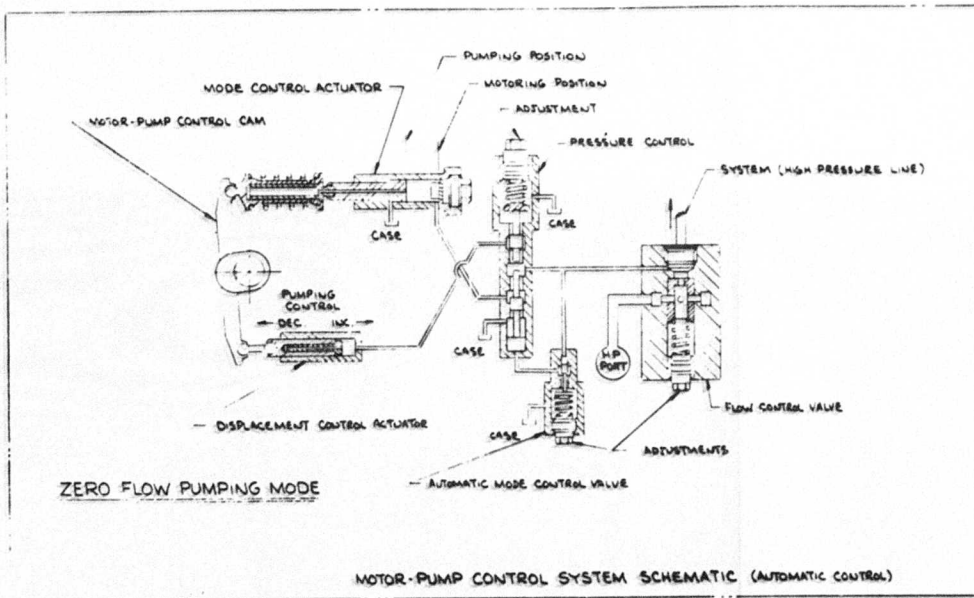

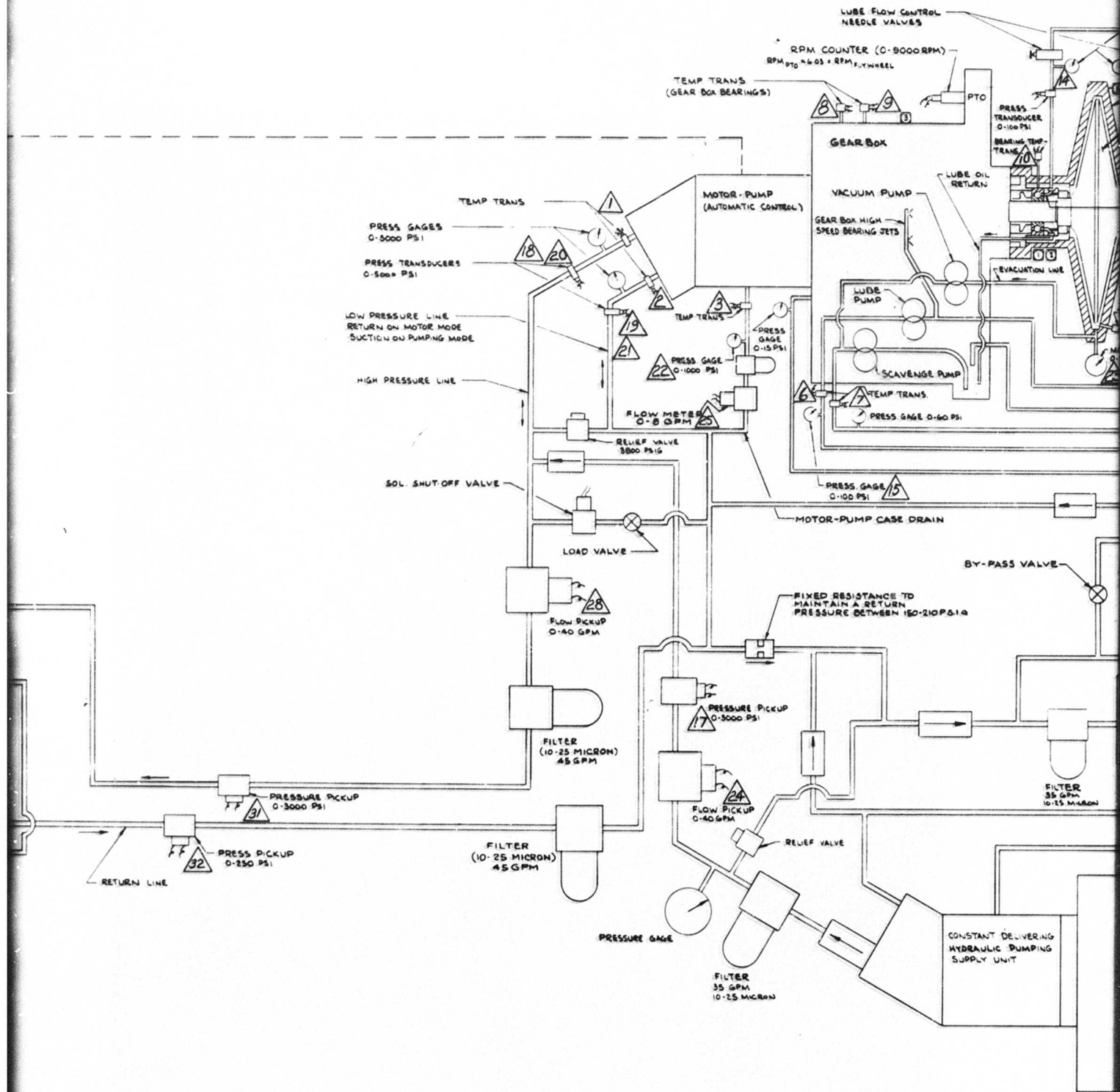

B

VIBRATION INSTRUMENTATION

(ACCELEROMETER LOCATIONS)

- ① AT EACH FLYWHEEL BEARING ON OUTSIDE OF HOUSING - HORIZONTAL PLANE 100-1000 CPS
- ② AT EACH FLYWHEEL BEARING ON OUTSIDE OF HOUSING - VERTICAL PLANE 100-1000 CPS
- ③ ON OUTSIDE TOP OF GEAR BOX - VERTICAL PLANE 10-300 CPS
- ④ ON FLYWHEEL HOUSING ON AXIAL PLANE OF FLYWHEEL SHAFT - 100-1000 CPS
- ⑤ ON FLYWHEEL HOUSING AT TIP OF FLYWHEEL - HORIZONTAL PLANE 100-1000 CPS

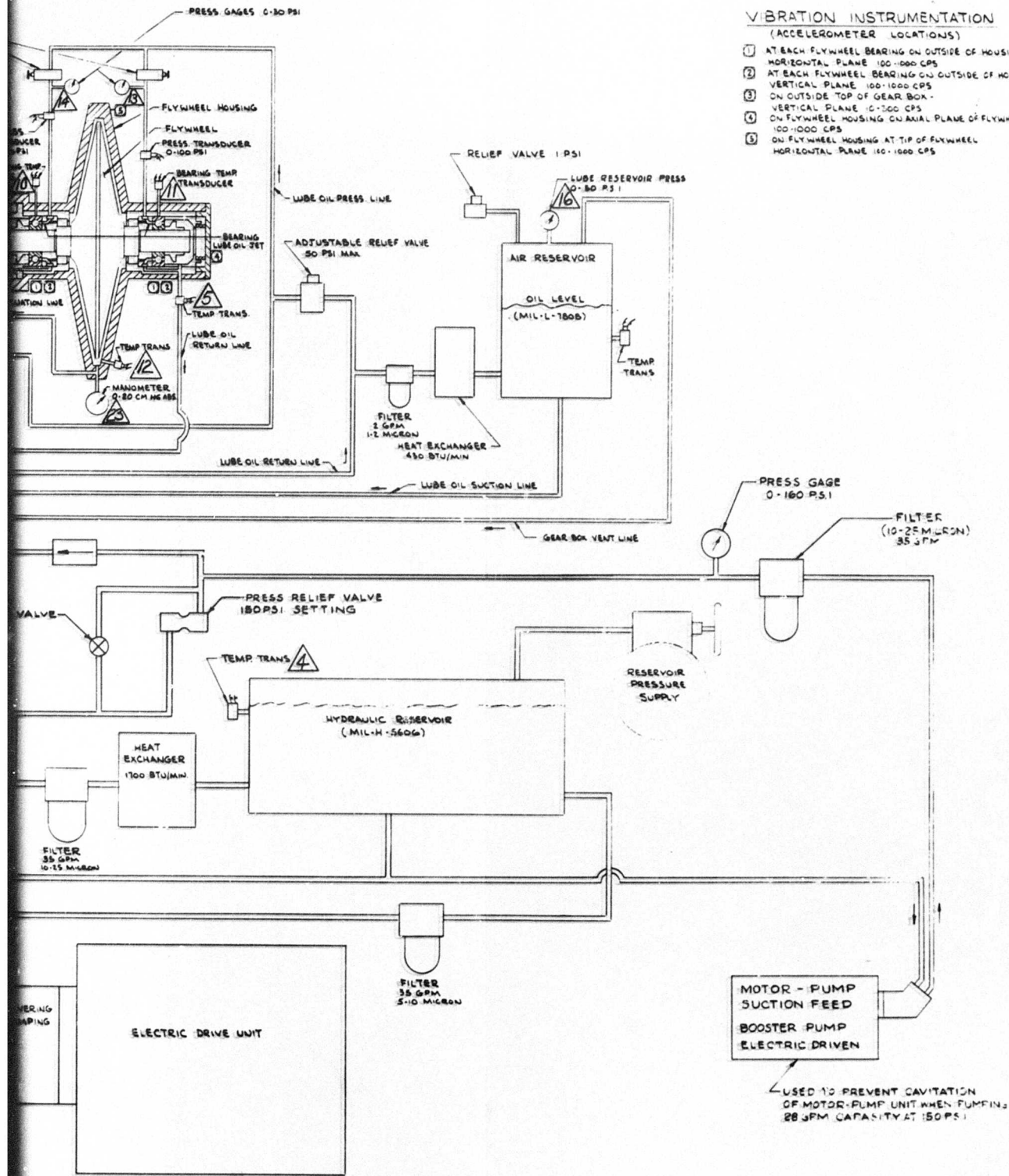

CODE  INDICATES TEST POINTS ON DATA SHEET

Figure 43.

SCHEMATIC-ENERGY STORAGE SUBSTATION
CONTINUOUS DUTY CYCLE SIMULATOR

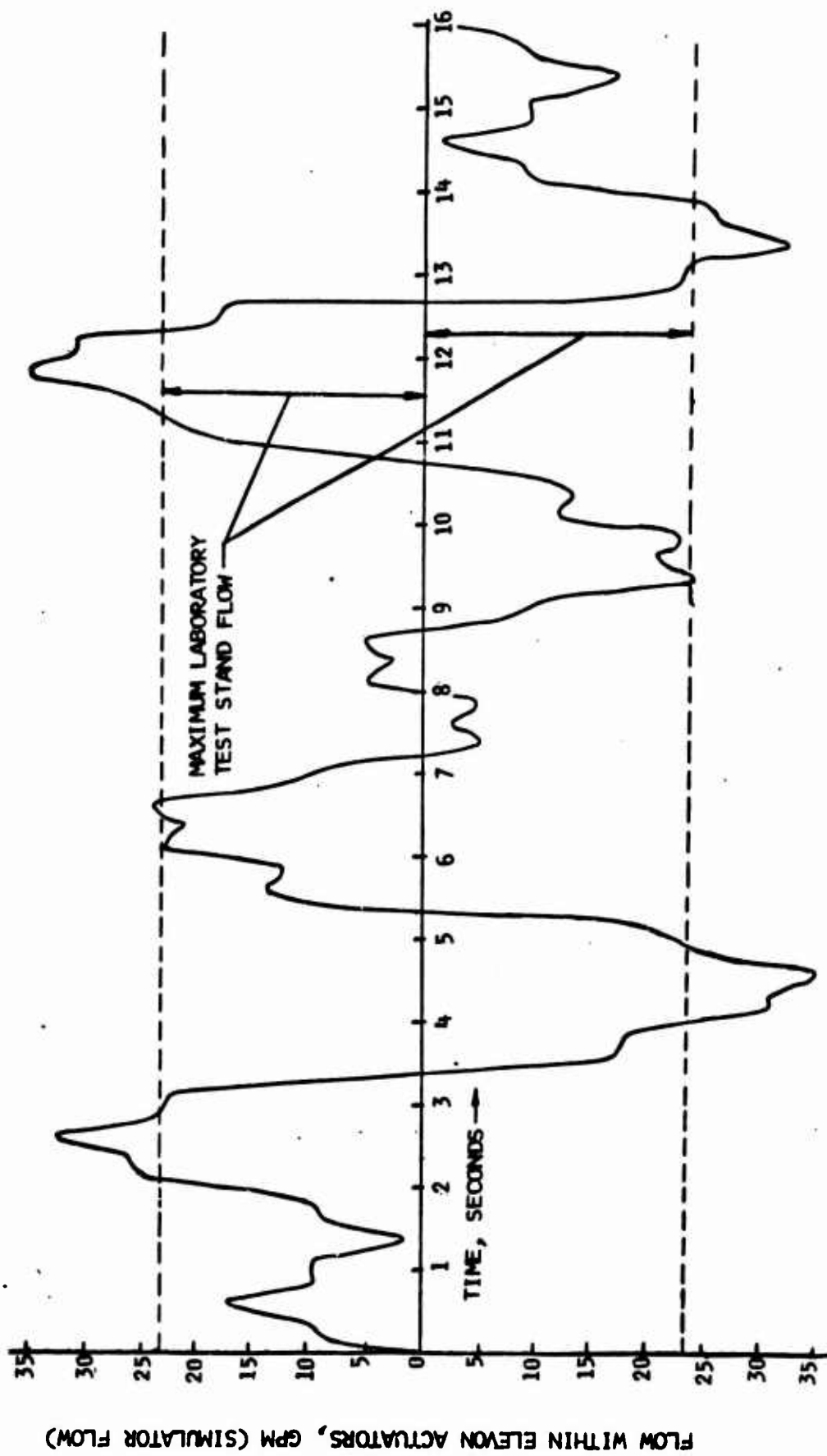

FLOW CHARACTERISTICS OF CONTINUOUS DUTY CYCLE SIMULATOR ENDURANCE TEST SPECIMEN

Figure 44. Continuous Duty Cycle Simulator

16 seconds) is considered to be one flow demand. Table XVI describes the distribution of these representative motions throughout the 5-hour flight missions which the endurance test was to demonstrate. The complete test spectrum consisted of 300 5-hour missions which were combined to demonstrate a total flight time and test time of 1,500 hours.

The first step in arriving at the above test spectrum was to establish a generalized estimate of the requirements for the flight control systems of a variety of aircraft including the XB-70 class vehicles. The mission was considered to be composed of a set of flight regimes, each of which had four types of flow demands. Table XVII is a breakdown of this information.

The duty cycle which was developed used table XVII as a demand-frequency guide. It also utilized flight-test data, analog data, and other experimental information to define the specific nature of the flow demands. The flywheel speed recovery time from these flow demands was small enough that equal spacing of the flow demands in each flight regime was acceptable and statistically compatible with pilot stick inputs. As an example the most severe flow demands occurred during emergency and attack. In this case 34 demands of 16 seconds each was accomplished within 900 seconds of elapsed time.

Surface dither (motion of the surface of small amplitude, but high frequency) was not considered to impose a load on the energy storage substation if the resultant flow demand was less than 50 percent of the maximum flow demand. These type demands would be supplied by the engine-driven pumping system in an actual air vehicle. This effectively eliminated columns A and B shown in table XVII from further consideration in constructing the test spectrum.

In the development of the test spectrum, major consideration was given to the magnitude of flow demands and the relative rates of their occurrences. The particular shape of figure 44 is a flow time history equivalent to three movements of the control surface from neutral to some deflection and then a return to neutral under varying flow demands. The three actuator movements are derived from a combination of control cycles which prevalently appear in flight-test data. The combination of flow rates was scaled to result in a 100 percent flow rate of the simulator.

C. ENDURANCE TEST

The endurance test, targeted for 1,500 hours and consisting of 300 simulated 5-hour flight missions was successfully completed. The only incidents which arose occurred near the beginning of the test. These are discussed at greater length further on.

Figures 45 and 46 are sample data records showing the velocity of the actuator, flywheel speed, and the pressure fluctuations which appeared in the system supply. Figure 47 is similar to figures 45 and 46 except that it was made using expanded ordinate scales to clarify the action which occurs during the transition between motoring and pumping. Since actuator velocity should be proportional to actuator flow demand, a comparison between the output flow shown on these figures and the input of figure 44 was an excellent

Table XVI
 BASIC DUTY CYCLE APPLICATIONS
 FOR
 ENDURANCE TESTING OF ENERGY STORAGE SUBSTATIONS
 (APPLICABLE TO B-70 CLASS AIRCRAFT)

| Mission Regime | Duration (Seconds) | Demands Per Regime C + D From Table II | Basic Duty Cycle Repetitions |
|----------------------|-----------------------|---|---------------------------------------|
| Takeoff, roll | 55 | 6 | 1 |
| Lift-off, climb | 1,300 | 8 | 2 |
| Cruise | 7,020 | 18 | 3 |
| Emergency, attack | 900 | 207 | 34 |
| Cruise | 7,020 | 18 | 3 |
| Descent | 1,340 | 24 | 4 |
| Approach and rollout | 380 | 7 | 1 |
| | <hr/> 18,015 | <hr/> 288 | <hr/> 48 |

Table XVII
 GENERALIZED CONTROL SYSTEM DUTY CYCLES
 (INCLUDING B-70 CLASS AIRCRAFT)

| Mission Regime | Duration (Seconds) | Surface Rate Classification * | | | |
|----------------------|-----------------------|-------------------------------|-----|-----|---|
| | | (No. of Demands Per Regime) | A | B | C |
| Takeoff, roll | 55 | 55 | 8 | 4 | 2 |
| Lift-off | 300 | 300 | 12 | 2 | 0 |
| Climb | 1,000 | 1,000 | 24 | 6 | 0 |
| Cruise | 7,020 | 7,020 | 430 | 16 | 2 |
| Emergency and attack | 900 | 900 | 380 | 200 | 7 |
| Cruise | 7,020 | 7,020 | 430 | 16 | 2 |
| Descent | 1,340 | 1,340 | 185 | 24 | 0 |
| Approach | 300 | 300 | 98 | 4 | 0 |
| Rollout | 80 | 80 | 12 | 2 | 1 |

* Surface rate classifications

| <u>Class</u> | <u>Percent Maximum Surface Rate</u> |
|--------------|-------------------------------------|
| A | 10 |
| B | 33 |
| C | 73 |
| D | 86 |

FLIGHT SEQUENCE NO. 10

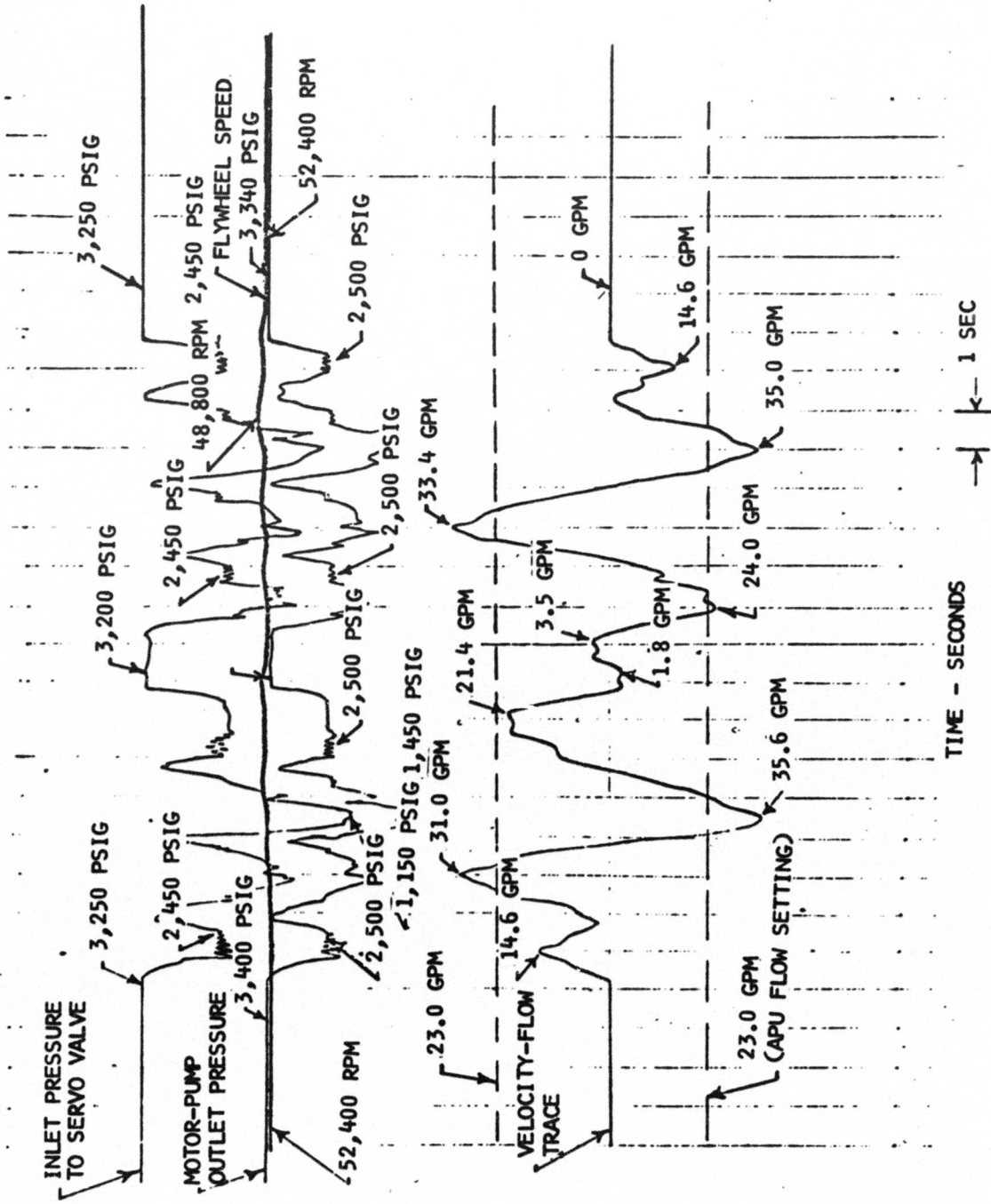

Figure 45. Continuous Duty Cycle Test Oscillograph Record

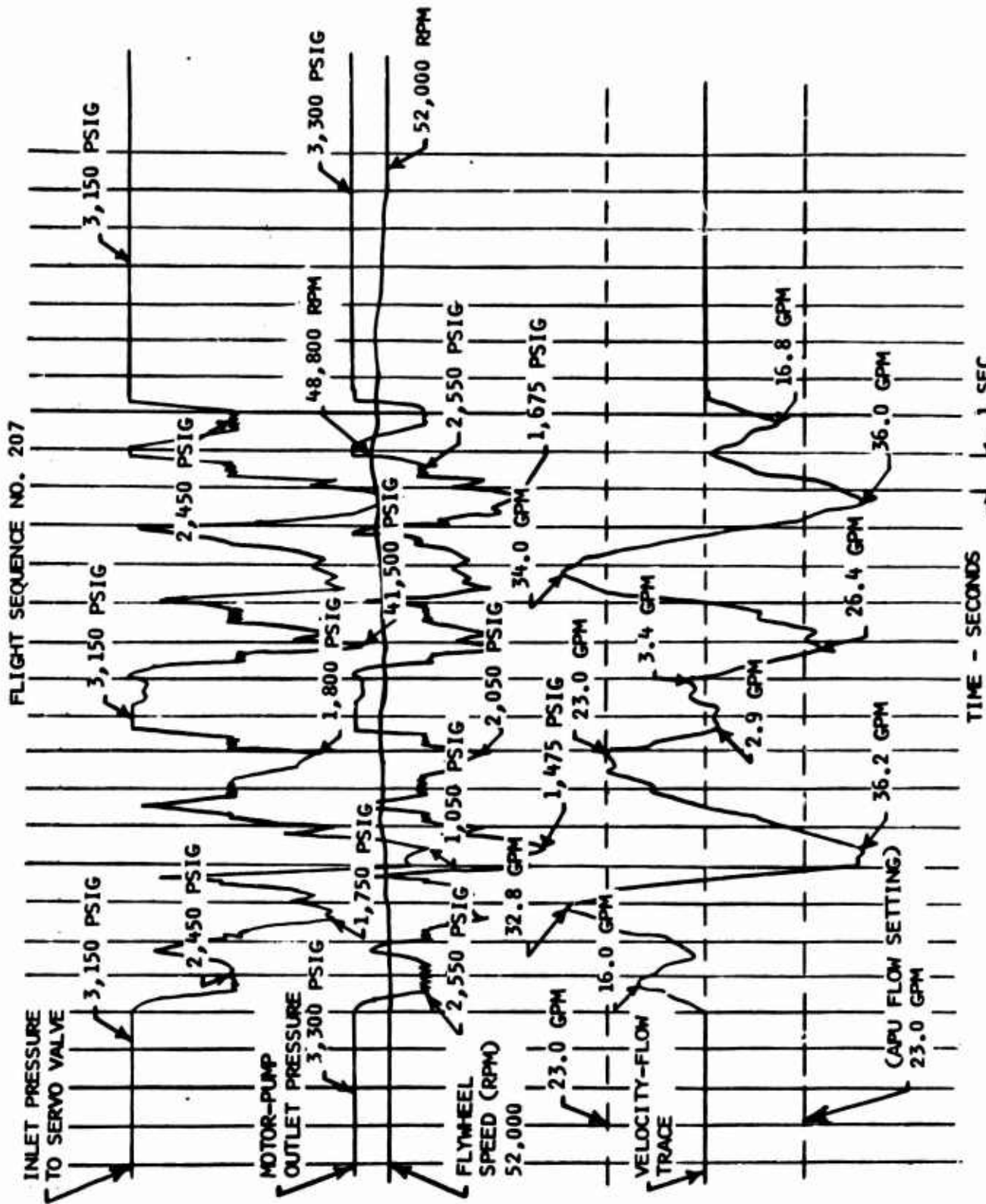

Figure 46. Continuous Duty Cycle Test Oscillograph Record

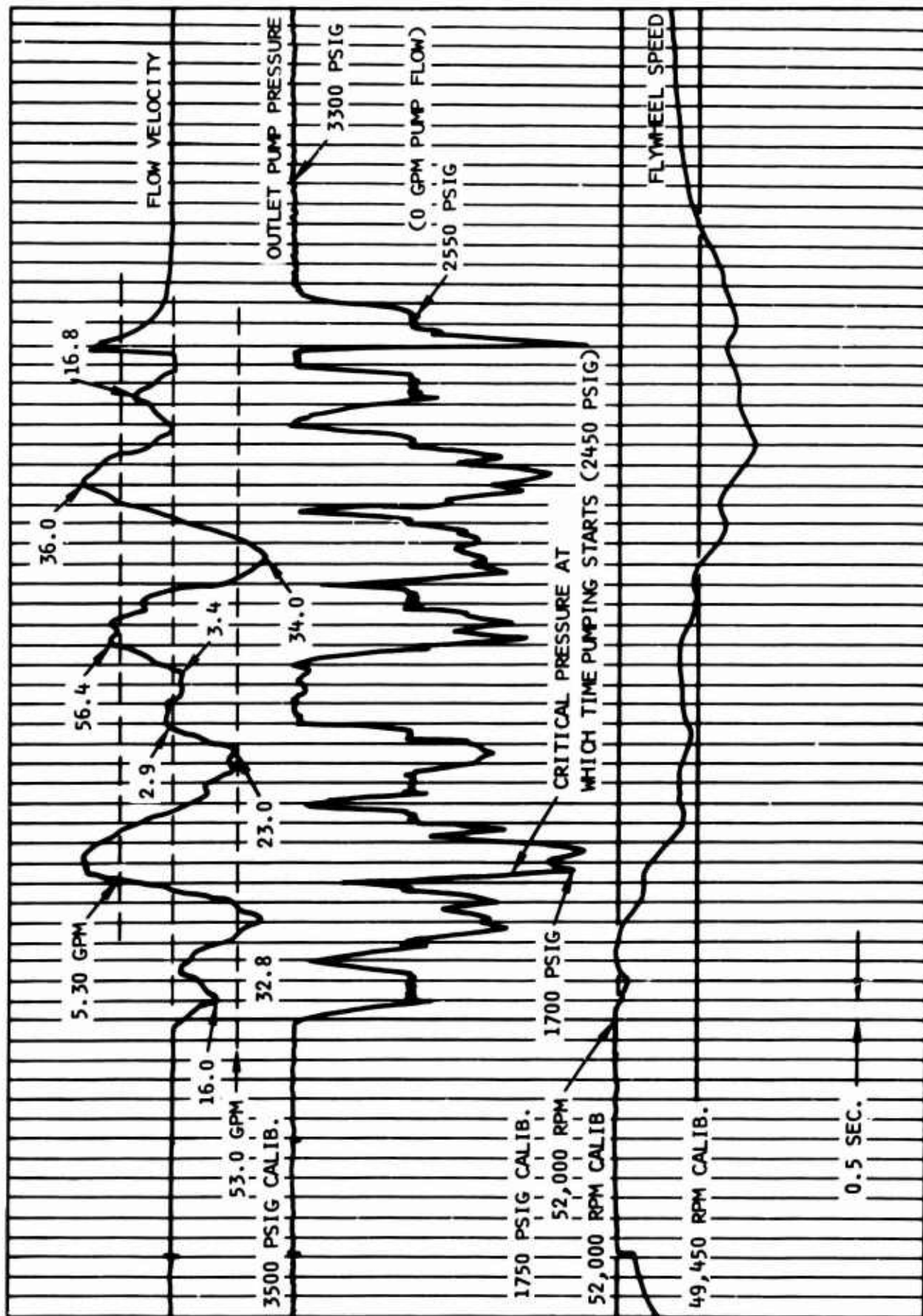

Figure 47. Oscillograph Record with Expanded Ordinate Scale

means to establish that the energy storage substation was being subjected to a representative duty cycle and was meeting its performance requirements. This was periodically done throughout the endurance test and in all cases the correlation between input and output was very good.

Table XVIII (eight pages) are data sheets taken during the tests. Each sheet was selected from among the 38 taken during the 1,500-hour test. Their selection was based upon some particular "out of the ordinary" event. These events ranged from start of test, through substation replacement due to failure to lubricant oil drain and change. Each column of data was taken at 5-hour intervals and does not show short term trends, such as a runaway temperature rise preceding bearing failure. However, they do show the long term changes, such as the gradual degradation in flywheel housing vacuum, which is discussed subsequently.

Figures 48 and 49 are plotted data points obtained from a digital computer which summarized the first 1,100 hours of testing with respect to average temperature, lubrication flow, and flywheel vacuum. The temperature plot (figure 48) is the average of the 12 temperatures taken for each of the 5-hour missions. It shows that, although variations in the operating temperature of the substation occurred, the performance was stable within a reasonable range. It should be remembered when examining the temperature range exhibited in figure 48 that the temperatures in the "shatter shield" box which surrounded the energy storage substation varied widely.

The "shatter shield" box was a device which was required by plant safety personnel until the structural failure characteristics of the flywheel were more accurately delineated. Unfortunately due to its thick woodlined walls it was an excellent insulator and prevented normal convective cooling of the substation. In an attempt to keep the temperature in the box at a normal 70° F a jury-rigged CO₂ system was used. With this arrangement, box temperatures varied widely (20° to 110° F) and helped account for the width of the temperature range in figure 48. However, the average temperature maintained in the box was approximately 70° F.

Figure 49 is a plot of the flywheel housing vacuum and is shown to be directly affected by the condition of the oil. As is noted later, the sharp dips to a lower absolute pressure are associated with routine oil changes.

During flight number 26 (125.7 hours), the flywheel vacuum gradually degraded and at a certain point the temperature of the housing suddenly climbed in a manner typical of a runaway overheat condition. At the same time it was noted that flywheel speed reduced as would be expected if significant power losses were to be suddenly introduced into the system. For these reasons the energy storage substation was shut down for investigation. There was evidence of oil leakage through the rotary seals at the flywheel hubs. However, a vacuum could still be maintained on the housing statically during bench tests, and the bearings appeared to be in operating condition. On the other hand a patch test of the lubricating system showed metal particles plus an unusual finely dispersed metallic-appearing residue. Because this type of contaminant had never been seen during previous flywheel failures it was decided to check the gearbox first. On this basis the gearbox was returned to the supplier for inspection and refurbishment.

Table XVIII
CONTINUOUS DUTY CYCLE TEST DATA

SUMMARY DATA SHEET NO: 1

DATE: 6-28-67

| Running Time of Test - Hours | | 5.3 | 10.5 | 16.0 | 21.5 | 26.5 | 29.8 | 35.5 | 40.5 |
|---|--|--------------|------------|------------|------------|------------|------------|------------|--------------|
| Vibration Amp. at Flywheel | Inboard | -- | -- | -- | -- | -- | -- | -- | -- |
| | Outboard | -- | -- | -- | -- | -- | -- | -- | -- |
| Bearings - g's | | | | | | | | | |
| (1) Flywheel Speed at Full Motoring - RPM | | 52,400 | 52,200 | 52,000 | 52,200 | 52,100 | 52,000 | 52,000 | 52,000 |
| (2) Minimum Speed Attain Under Load - RPM | | 48,000 | 48,200 | 48,000 | 48,000 | 48,000 | 48,000 | 48,000 | 48,000 |
| Total No. of Simulated Aircraft Flights | | 1 | 2 | 3 | 4 | 5 | 6 | 7 | 8 |
| Total No. of Basic Duty Cycle Repetitions | | 48 | 96 | 144 | 192 | 240 | 288 | 336 | 384 |
| NO. TEMPERATURE DATA - DEG. F | | | | | | | | | |
| 1 | Test Pump Inlet | 139 | 138 | 140 | 141 | 142 | 177 | 150 | 150 |
| 2 | Test Pump Return | 139 | 140 | 141 | 142 | 142 | 138 | 162 | 152 |
| 3 | Test Pump Case Drain | 185 | 182 | 185 | 182 | 182 | 188 | 190 | 196 |
| 4 | Main Hyd. Reservoir Supply | 130 | 131 | 135 | 132 | 134 | 138 | 132 | 141 |
| 5 | Lube Oil Return | 192 | 190 | 182 | 174 | 169 | 163 | 189 | 177 |
| 6 | Lube Oil Suction | 94 | 92 | 91 | 91 | 94 | 97 | 111 | 103 |
| 7 | Scavange Oil Return | 148 | 142 | 145 | 140 | 138 | 136 | 143 | 150 |
| 8 | Gear Box Bearing Adjacent Pump | 198 | 190 | 193 | 182 | 170 | 183 | 192 | 190 |
| 9 | Gear Box Bearing Adjacent Flywheel | 200 | 200 | 195 | 189 | 182 | 186 | 195 | 192 |
| 10 | Inboard Flywheel Bearing | 192 | 190 | 189 | 175 | 183 | 174 | 197 | 191 |
| 11 | Outboard Flywheel Bearing | 189 | 185 | 175 | 175 | 164 | 143 | 175 | 152 |
| 12 | Flywheel Case Housing | 168 | 155 | 110 | 104 | 90 | 120 | 128 | 100 |
| NO. SYSTEM PRESSURE DATA - PSIG | | | | | | | | | |
| 13 | Outboard Flywheel Bearing | 30 | 30 | 30 | 31 | 30 | 30 | 31 | 30 |
| 14 | Inboard Flywheel Bearing | 33 | 32 | 32 | 32 | 30 | 31 | 32 | 32 |
| 15 | Lube Pump Pressure Port | 51 | 50 | 50 | 51 | 50 | 51 | 50 | 50 |
| 16 | Lube Reservoir | 0 | 0 | 0 | 0 | 0 | 0 | 0 | 0 |
| 17 | Hyd Supply Pump Press. Port | 3350 | 3350 | 3350 | 3450 | 3500 | 3440 | 3450 | 3450 |
| 18 | Test Motor Press. Port (Motoring) | 3350 | 3350 | 3350 | 3450 | 3500 | 3400 | 3400 | 3400 |
| 19 | Test Motor Return Port (Motoring) | 120 | 120 | 120 | 120 | 120 | 120 | 120 | 120 |
| 20 | Test Pump Press. Range (Pumping) | 2550 1850 | ← | | | | | → | 2200 1450 |
| 21 | Test Pump Suction Press. (Pumping) | 210 120 | 210 120 | 210 120 | 210 120 | 210 120 | 210 120 | 210 120 | 210 120 |
| 22 | Test Motor - Pump Case Drain | 210 120 | 210 120 | 210 120 | 210 120 | 210 120 | 210 120 | 210 120 | 210 120 |
| 23 | Pressure at Flywheel Tip - CM Hg Ab. | 3.4 | 3.5 | 3.4 | 3.2 | 3.1 | 3.2 | 3.3 | 3.2 |
| NO. FLUID FLOW DATA - GPM | | | | | | | | | |
| 24 | Inlet Flow to Meter | 16.0 | 16.0 | 16.0 | 16.0 | 16.0 | 15.8 | 16.0 | 16.0 |
| 25 | Motor-Pump Case Drain Flow | 0.65 | 0.65 | 0.70 | 0.70 | 0.71 | 0.73 | 0.71 | 0.72 |
| 26 | A.P.U. Flow Rate | 23.0 | 23.0 | 23.0 | 23.0 | 23.0 | 23.0 | 23.0 | 23.0 |
| 27 | Combined A.P.U. & Test Pump Flow (Max) | 36.0 | 36.0 | 36.0 | 35.9 | 35.9 | 35.9 | 35.8 | 35.8 |
| 28 | Test Pump Flow Rate - Range | 0-13 | 0-13 | 0-13 | 0-12.9 | 0-12.9 | 0-12.8 | 0-12.8 | 0-12.8 |
| 29 | Outboard Bearing Lube Flow - cc/min | 750 | 750 | 750 | 760 | 750 | 750 | 760 | 760 |
| 30 | Inboard Bearing Lube Flow - cc/min | 820 | 820 | 820 | 820 | 800 | 810 | 820 | 820 |

Table XVIII (Continued)

CONTINUOUS DUTY CYCLE TEST DATA

SUMMARY DATA SHEET NO: 2DATE: 7-5-67

| Running Time of Test - Hours | 45.5 | 50.5 | 55.5 | 60.5 | 65.5 | 70.5 | 75.8 | 81.0 |
|---|--|--------|--------|--------|--------|--------|--------|--------|
| Vibration Amp. at Flywheel | Inboard | -- | -- | -- | -- | -- | 3* | 10 |
| Bearings - g's | Outboard | -- | -- | -- | -- | -- | 8* | 7 |
| (1) Flywheel Speed at Full Motoring - RPM | 2,000 | 1,800 | 1,800 | 1,900 | 2,000 | 1,800 | 1,800 | 1,800 |
| (2) Minimum Speed Attain Under Load - RPM | 1,800 | 1,800 | 1,800 | 1,800 | 1,800 | 1,800 | 1,900 | 1,900 |
| Total No. of Simulated Aircraft Flights | 9 | 10 | 11 | 12 | 13 | 14 | 15 | 16 |
| Total No. of Basic Duty Cycle Repetitions | 432 | 480 | 528 | 576 | 624 | 672 | 720 | 768 |
| NO. TEMPERATURE DATA - DEG. F | | | | | | | | |
| 1 | Test Pump Inlet | 155 | 142 | 160 | 162 | 136 | 160 | 157 |
| 2 | Test Pump Return | 155 | 144 | 160 | 161 | 139 | 160 | 157 |
| 3 | Test Pump Case Drain | 190 | 190 | 195 | 195 | 183 | 193 | 190 |
| 4 | Main Hyd. Reservoir Supply | 133 | 136 | 145 | 142 | 130 | 142 | 140 |
| 5 | Lube Oil Return | 158 | 178 | 195 | 186 | 170 | 190 | 160 |
| 6 | Lube Oil Suction | 98 | 97 | 102 | 101 | 80 | 98 | 100 |
| 7 | Scavange Oil Return | 140 | 145 | 152 | 150 | 135 | 146 | 137 |
| 8 | Gear Box Bearing Adjacent Pump | 183 | 186 | 195 | 195 | 175 | 180 | 170 |
| 9 | Gear Box Bearing Adjacent Flywheel | 183 | 187 | 195 | 195 | 175 | 180 | 172 |
| 10 | Inboard Flywheel Bearing | 183 | 180 | 195 | 183 | 170 | 185 | 172 |
| 11 | Outboard Flywheel Bearing | 165 | 173 | 182 | 178 | 160 | 177 | 160 |
| 12 | Flywheel Case Housing | 98 | 100 | 125 | 108 | 125 | 120 | 105 |
| NO. SYSTEM PRESSURE DATA - PSIG | | | | | | | | |
| 13 | Outboard Flywheel Bearing | 31 | 30 | 29 | 30 | 30 | 32 | 31 |
| 14 | Inboard Flywheel Bearing | 30 | 31 | 30 | 31 | 30 | 32 | 31 |
| 15 | Lube Pump Pressure Port | 51 | 51 | 50 | 49.5 | 51 | 52 | 52 |
| 16 | Lube Reservoir | 0 | 0 | 0 | 0 | 0 | 0 | 0 |
| 17 | Hyd Supply Pump Press. Port | 3450 | 3425 | 3400 | 3400 | 3400 | 3400 | 3400 |
| 18 | Test Motor Press. Port (Motoring) | 3400 | 3400 | 3375 | 3375 | 3375 | 3375 | 3375 |
| 19 | Test Motor Return Port (Motoring) | 120 | 120 | 120 | 120 | 120 | 120 | 120 |
| 20 | Test Pump Press. Range (Pumping) | 1450 | ← | | | | | 1450 |
| 21 | Test Pump Suction Press. (Pumping) | 210 | 210 | 210 | 210 | 210 | 210 | 210 |
| 22 | Test Motor - Pump Case Drain | 210 | 210 | 210 | 210 | 210 | 210 | 210 |
| 23 | Pressure at Flywheel Tip - CM Hg Ab. | 3.2 | 3.2 | 3.2 | 3.1 | 2.4 | 2.9 | 2.7 |
| NO. FLUID FLOW DATA - GPM | | | | | | | | |
| 24 | Inlet Flow to Meter | 16.0 | 16.0 | 16.0 | 16.0 | 16.0 | 16.0 | 16.0 |
| 25 | Motor-Pump Case Drain Flow | 0.75 | 0.75 | 0.75 | 0.80 | 0.75 | 0.75 | 0.75 |
| 26 | A.P.U. Flow Rate | 23 | 23 | 23 | 23 | 23 | 23 | 23 |
| 27 | Combined A.P.U. & Test Pump Flow (Max) | 35.8 | 35.6 | 35.6 | 35.6 | 35.8 | 35.8 | 35.8 |
| 28 | Test Pump Flow Rate - Range | 0-12.8 | 0-12.8 | 0-12.8 | 0-12.8 | 0-12.8 | 0-12.8 | 0-12.8 |
| 29 | Outboard Bearing Lube Flow - cc/min | 760 | 750 | 740 | 740 | 740 | 760 | 760 |
| 30 | Inboard Bearing Lube Flow - cc/min | 820 | 820 | 820 | 820 | 810 | 830 | 820 |

*Started to record vibration g' load on inboard and outboard flywheel bearings.

Table XVIII (Continued)

CONTINUOUS DUTY CYCLE TEST DATA

SUMMARY DATA SHEET NO: 4

DATE: 7-13-67

| | | | | | | | | | |
|---|--|--------------|------------|------------|------------|------------|------------|------------|--------------|
| Running Time of Test - Hours | | 128.4 | 133.4 | 138.7 | 143.7 | 148.7 | 153.9 | 158.9 | 163.4 |
| Vibration Amp. at Flywheel | Inboard | 8.0 | 8.5 | 10.0 | 10.0 | 10.0 | 10.6 | 10.0 | 10.5 |
| | Outboard | 6.5 | 5.9 | 7.8 | 6.7 | 7.8 | 7.8 | 7.8 | 7.8 |
| Bearings - g's | | | | | | | | | |
| (1) Flywheel Speed at Full Motoring - RPM | | 50,400 | 50,400 | 52,200 | 51,200 | 51,600 | 52,100 | 51,600 | 52,000 |
| (2) Minimum Speed Attain Under Load - RPM | | 48,000 | 48,000 | 48,000 | 48,000 | 48,000 | 48,000 | 48,000 | 48,000 |
| Total No. of Simulated Aircraft Flights | | 25 | 26 | 27 | 28 | 29 | 30 | 31 | 32 |
| Total No. of Basic Duty Cycle Repetitions | | 1200 | 1248 | 1296 | 1344 | 1392 | 1440 | 1488 | 1536 |
| NO. TEMPERATURE DATA - DEG. F | | | | | | | | | |
| 1 | Test Pump Inlet | 142 | 149 | 133 | 162 | 158 | 100 | 110 | 101 |
| 2 | Test Pump Return | 142 | 149 | 150 | 161 | 158 | 110 | 111 | 103 |
| 3 | Test Pump Case Drain | 190 | 185 | 190 | 187 | 189 | 161 | 162 | 162 |
| 4 | Main Hyd. Reservoir Supply | 135 | 132 | 120 | 145 | 141 | 98 | 92 | 98 |
| 5 | Lube Oil Return | 142 | 138 | 142 | 145 | 142 | 160 | 158 | 166 |
| 6 | Lube Oil Suction | 79 | 73 | 80 | 82 | 75 | 88 | 80 | 93 |
| 7 | Scavange Oil Return | 105 | 111 | 110 | 120 | 112 | 111 | 107 | 115 |
| 8 | Gear Box Bearing Adjacent Pump | 172 | 170 | 170 | 183 | 176 | 170 | 171 | 178 |
| 9 | Gear Box Bearing Adjacent Flywheel | 148 | 148 | 155 | 154 | 150 | 130 | 158 | 155 |
| 10 | Inboard Flywheel Bearing | 163 | 159 | 145 | 162 | 145 | 141 | 148 | 168 |
| 11 | Outboard Flywheel Bearing | 142 | 135 | 135 | 132 | 140 | 140 | 141 | 162 |
| 12 | Flywheel Case Housing | 130 | 118 | 100 | 112 | 122 | 98 | 98 | 145 |
| NO. SYSTEM PRESSURE DATA - PSIG | | | | | | | | | |
| 13 | Outboard Flywheel Bearing | 30 | 30 | 30 | 32 | 30 | 27.5 | 29 | 29 |
| 14 | Inboard Flywheel Bearing | 30 | 30 | 29 | 31 | 29 | 27 | 28 | 28 |
| 15 | Lube Pump Pressure Port | 57 | 59 | 56 | 56 | 56 | 53 | 53 | 52 |
| 16 | Lube Reservoir | 0 | 0 | 0 | 0 | 0 | 0 | 0 | 0 |
| 17 | Hyd Supply Pump Press. Port | 3475 | 3500 | 3450 | 3450 | 3450 | 3400 | 3400 | 3400 |
| 18 | Test Motor Press. Port (Motoring) | 3460 | 3450 | 3400 | 3400 | 3400 | 3350 | 3350 | 3375 |
| 19 | Test Motor Return Port (Motoring) | 120 | 120 | 120 | 120 | 120 | 135 | 135 | 110 |
| 20 | Test Pump Press. Range (Pumping) | 2520 1450 | ← | | | | | → | 2520 1450 |
| 21 | Test Pump Suction Press. (Pumping) | 210 120 | 210 120 | 210 120 | 210 120 | 210 120 | 215 135 | 215 135 | 200 110 |
| 22 | Test Motor - Pump Case Drain | 210 120 | 210 120 | 210 120 | 210 120 | 210 120 | 215 135 | 215 135 | 200 110 |
| 23 | Pressure at Flywheel Tip - CM Hg Ab. | 4.8 | 3.8 | 3.4 | 4.8 | 2.9 | 2.7 | 2.7 | 2.0 |
| NO. FLUID FLOW DATA - GPM | | | | | | | | | |
| 24 | Inlet Flow to Meter | 15.5 | 15.5 | 16.0 | 16.0 | 16.0 | 16.0 | 16.0 | 16.0 |
| 25 | Motor-Pump Case Drain Flow | 0.65 | 0.65 | 0.75 | 0.75 | 0.75 | 0.60 | 0.60 | 0.62 |
| 26 | A.P.U. Flow Rate | 23 | 23 | 23 | 23 | 23 | 23 | 23 | 23 |
| 27 | Combined A.P.U. & Test Pump Flow (Max) | 36.0 | 36.1 | 36.1 | 36.1 | 36.0 | 36.0 | 36.0 | 36.0 |
| 28 | Test Pump Flow Rate - Range | 0-13 | 0-13.1 | 0-13.1 | 0-13.1 | 0-13 | 0-13 | 0-13 | 0-13 |
| 29 | Outboard Bearing Lube Flow - cc/min | 465 | 465 | 465 | 475 | 465 | 425 | 450 | 450 |
| 30 | Inboard Bearing Lube Flow - cc/min | 485 | 485 | 465 | 470 | 465 | 445 | 455 | 455 |

*Testing of flywheel sub-station No. 2 began at 125.3 hr. into the program.

Table XVIII (Continued)

CONTINUOUS DUTY CYCLE TEST DATA

SUMMARY DATA SHEET NO: 5

DATE: 7-19-67

| Running Time of Test - Hours | | 168.9 | 174.2 | 179.4 | 184.4 | 189.4 | 194.4 | 199.4 | 203.8 |
|---|--|--------------|------------|------------|----------------|------------|------------|------------|--------------|
| Vibration Amp. at Flywheel | Inboard | 13.6 | 10.7 | 9.7 | 10.3 | 12.0 | 11.6 | 11.5 | 11.0 |
| | Outboard | 8.5 | 7.8 | 7.8 | 7.8 | 7.8 | 7.8 | 7.8 | 6.5 |
| Bearings - g's | | | | | | | | | |
| (1) Flywheel Speed at Full Motoring - RPM | | 52,000 | 52,000 | 52,000 | 52,000 | 52,000 | 52,000 | 52,000 | 52,000 |
| (2) Minimum Speed Attain Under Load - RPM | | 48,000 | 48,000 | 48,000 | 48,000 | 48,000 | 48,000 | 48,000 | 48,500 |
| Total No. of Simulated Aircraft Flights | | 33 | 34 | 35 | 36 | 37 | 38 | 39 | 40 |
| Total No. of Basic Duty Cycle Repetitions | | 1584 | 1632 | 1680 | 1728 | 1776 | 1824 | 1872 | 1920 |
| NO. TEMPERATURE DATA - DEG. F | | | | | | | | | |
| 1 | Test Pump Inlet | 102 | 110 | 115 | 112 | 100 | 101 | 122 | 103 |
| 2 | Test Pump Return | 105 | 110 | 115 | 113 | 100 | 102 | 121 | 103 |
| 3 | Test Pump Case Drain | 160 | 160 | 155 | 157 | 155 | 156 | 132 | 160 |
| 4 | Main Hyd. Reservoir Supply | 92 | 92 | 90 | 91 | 90 | 94 | 114 | 100 |
| 5 | Lube Oil Return | 158 | 165 | 165 | 165 | 170 | 157 | 138 | 153 |
| 6 | Lube Oil Suction | 85 | 90 | 90 | 89 | 95 | 95 | 111 | 100 |
| 7 | Scavange Oil Return | 105 | 130 | 122 | 125 | 140 | 118 | 110 | 125 |
| 8 | Gear Box Bearing Adjacent Pump | 168 | 180 | 168 | 168 | 190 | 169 | 147 | 175 |
| 9 | Gear Box Bearing Adjacent Flywheel | 154 | 180 | 168 | 168 | 190 | 169 | 150 | 170 |
| 10 | Inboard Flywheel Bearing | 150 | 165 | 140 | 140 | 170 | 151 | 140 | 150 |
| 11 | Outboard Flywheel Bearing | 145 | 155 | 140 | 140 | 170 | 145 | 141 | 150 |
| 12 | Flywheel Case Housing | 106 | 140 | 130 | 132 | 165 | 129 | 130 | 135 |
| NO. SYSTEM PRESSURE DATA - PSIG | | | | | | | | | |
| 13 | Outboard Flywheel Bearing | 30 | 32 | 29 | 29 | 34 | 32 | 32 | 32 |
| 14 | Inboard Flywheel Bearing | 30 | 32 | 30 | 30 | 32 | 30 | 30 | 31 |
| 15 | Lube Pump Pressure Port | 56 | 57 | 56 | 56 | 57 | 56 | 56 | 55 |
| 16 | Lube Reservoir | 0 | 0 | 0 | 0 | 0 | 0 | 0 | 0 |
| 17 | Hyd Supply Pump Press. Port | 3400 | 3400 | 3400 | 3400 | 3400 | 3400 | 3400 | 3400 |
| 18 | Test Motor Press. Port (Motoring) | 3375 | 3375 | 3380 | 3375 | 3375 | 3375 | 3375 | 3375 |
| 19 | Test Motor Return Port (Motoring) | 120 | 110 | 110 | 110 | 120 | 120 | 112 | 110 |
| 20 | Test Pump Press. Range (Pumping) | 2550 1450 | ← | | | | | → | 2220 1450 |
| 21 | Test Pump Suction Press. (Pumping) | 210 120 | 210 110 | 210 110 | 210 110 | 210 120 | 210 120 | 210 112 | 210 110 |
| 22 | Test Motor - Pump Case Drain | 210 120 | 210 110 | 210 110 | 210 110 | 210 120 | 210 120 | 210 112 | 210 110 |
| 23 | Pressure at Flywheel Tip - CM Hg Ab. | 2.4 | 2.5 | 2.2 | 2.3 | 2.7 | 2.2 | 2.6 | 2.6 |
| NO. FLUID FLOW DATA - GPM | | | | | | | | | |
| 24 | Inlet Flow to Meter | 16.0 | 16.0 | 16.0 | 16.0 | 16.0 | 16.0 | 16.0 | 16.0 |
| 25 | Motor-Pump Case Drain Flow | 0.60 | 0.60 | 0.65 | 0.65 | 0.65 | 0.65 | 0.65 | 0.65 |
| 26 | A.P.U. Flow Rate | 23 | 23 | 23 | 23 | 23 | 23 | 23 | 23 |
| 27 | Combined A.P.U. & Test Pump Flow (Max) | 36.0 | 35.9 | 35.9 | 35.8 | 35.9 | 35.9 | 36.0 | 36.0 |
| 28 | Test Pump Flow Rate - Range | 0-13 | 0-12.9 | 0-12.9 | 0-12.80, 12.80 | 0-12.80 | 0-12.9 | 0-13 | 0-13 |
| 29 | Outboard Bearing Lube Flow - cc/min | 465 | 760 | 750 | 750 | 800 | 740 | 740 | 740 |
| 30 | Inboard Bearing Lube Flow - cc/min | 485 | 830 | 800 | 800 | 820 | 790 | 790 | 805 |

* 2nd start of flywheel sub-station No. 1 after replacement of bearings and seals.

Table XVIII (Continued)

CONTINUOUS DUTY CYCLE TEST DATA

SUMMARY DATA SHEET NO: 10

DATE: 8-8-67

| | | | | | | | | | |
|---|--|--------------|------------|------------|------------|------------|------------|------------|--------------|
| Running Time of Test - Hours | | 368.5 | 373.7 | 378.8 | 383.9 | 388.7 | 394.3 | 399.0 | 404.0 |
| Vibration Amp. at Flywheel | Inboard | 10.8 | 10.2 | 7.8 | 10.3 | 10.8 | 7.4 | 10.9 | 10.3 |
| | Outboard | 6.5 | 7.3 | 6.1 | 6.5 | 7.8 | 6.5 | 6.7 | 7.8 |
| Bearings - g's | | | | | | | | | |
| (1) Flywheel Speed at Full Motoring - RPM | | 52000 | 52000 | 52400 | 52400 | 52200 | 52200 | 52200 | 52200 |
| (2) Minimum Speed Attain Under Load - RPM | | 49000 | 49000 | 49000 | 49000 | 49000 | 49000 | 49000 | 49000 |
| Total No. of Simulated Aircraft Flights | | 73 | 74 | 75 | 76 | 77 | 78 | 79 | 80 |
| Total No. of Basic Duty Cycle Repetitions | | 3504 | 3552 | 3600 | 3648 | 3696 | 3744 | 3792 | 3840 |
| NO. TEMPERATURE DATA - DEG. F | | | | | | | | | |
| 1 | Test Pump Inlet | 93 | 93 | 98 | 90 | 95 | 95 | 95 | 98 |
| 2 | Test Pump Return | 102 | 102 | 102 | 100 | 100 | 98 | 100 | 105 |
| 3 | Test Pump Case Drain | 145 | 140 | 138 | 138 | 140 | 138 | 140 | 143 |
| 4 | Main Hyd. Reservoir Supply | 90 | 90 | 85 | 85 | 90 | 85 | 90 | 95 |
| 5 | Lube Oil Return | 150 | 167 | 141 | 160 | 170 | 158 | 170 | 170 |
| 6 | Lube Oil Suction | 90 | 85 | 80 | 80 | 85 | 80 | 80 | 90 |
| 7 | Scavange Oil Return | 120 | 120 | 115 | 120 | 125 | 118 | 120 | 125 |
| 8 | Gear Box Bearing Adjacent Pump | 160 | 163 | 158 | 160 | 165 | 160 | 160 | 165 |
| 9 | Gear Box Bearing Adjacent Flywheel | 165 | 175 | 160 | 170 | 180 | 170 | 170 | 180 |
| 10 | Inboard Flywheel Bearing | 150 | 160 | 152 | 150 | 170 | 165 | 160 | 165 |
| 11 | Outboard Flywheel Bearing | 140 | 155 | 138 | 145 | 155 | 140 | 155 | 157 |
| 12 | Flywheel Case Housing | 120 | 130 | 105 | 120 | 155 | 135 | 140 | 145 |
| NO. SYSTEM PRESSURE DATA - PSIG | | | | | | | | | |
| 13 | Outboard Flywheel Bearing | 34 | 34 | 33 | 33 | 34 | 33 | 34 | 33 |
| 14 | Inboard Flywheel Bearing | 34 | 34 | 33 | 33 | 34 | 33 | 34 | 33 |
| 15 | Lube Pump Pressure Port | 56 | 55 | 57 | 56 | 55 | 57 | 56 | 56 |
| 16 | Lube Reservoir | 0 | 0 | 0 | 0 | 0 | 0 | 0 | 0 |
| 17 | Hyd Supply Pump Press. Port | 3350 | 3350 | 3350 | 3350 | 3350 | 3350 | 3350 | 3350 |
| 18 | Test Motor Press. Port (Motoring) | 3300 | 3300 | 3300 | 3300 | 3300 | 3300 | 3300 | 3300 |
| 19 | Test Motor Return Port (Motoring) | 115 | 115 | 115 | 115 | 115 | 115 | 115 | 115 |
| 20 | Test Pump Press. Range (Pumping) | 2550 1475 | ← | | | | | → | 2550 1475 |
| 21 | Test Pump Suction Press. (Pumping) | 115 210 | 115 210 | 115 210 | 115 210 | 115 210 | 115 210 | 115 210 | 115 210 |
| 22 | Test Motor - Pump Case Drain | 115 210 | 115 210 | 115 210 | 115 210 | 115 210 | 115 210 | 115 210 | 115 210 |
| 23 | Pressure at Flywheel Tip - CM Hg Ab. | 3.1 | 3.2 | 3.0 | 3.1 | 3.1 | 3.1 | 3.2 | 3.2 |
| NO. FLUID FLOW DATA - GPM | | | | | | | | | |
| 24 | Inlet Flow to Meter | 16.0 | 16.0 | 16.0 | 16.0 | 16.0 | 16.0 | 16.0 | 16.0 |
| 25 | Motor-Pump Case Drain Flow | 0.65 | 0.70 | 0.65 | 0.65 | 0.70 | 0.67 | 0.67 | 0.70 |
| 26 | A.P.U. Flow Rate | 23 | 23 | 23 | 23 | 23 | 23 | 23 | 23 |
| 27 | Combined A.P.U. & Test Pump Flow (Max) | 36.0 | 36.0 | 36.0 | 36.0 | 36.0 | 35.9 | 35.9 | 36.0 |
| 28 | Test Pump Flow Rate - Range | 0-13 | 0-13 | 0-13 | 0-13 | 0-13 | 0-12.9 | 0-12.9 | 0-13 |
| 29 | Outboard Bearing Lube Flow - cc/min | 770 | 770 | 765 | 765 | 770 | 765 | 770 | 765 |
| 30 | Inboard Bearing Lube Flow - cc/min | 830 | 830 | 825 | 825 | 830 | 825 | 830 | 825 |

* NOTE: Min. speed during "attach" 49,500 RPM. Recovered to 51,500 between cycles with 52,400 max. regulated speed after "attach".

Table XVIII (Continued)

CONTINUOUS DUTY CYCLE TEST DATA

SUMMARY DATA SHEET NO: 16

*

DATE: 8-29-67

| Running Time of Test - Hours | 610.0 | 615.1 | 620.2 | 625.1 | 630.2 | 635.0 | 640.0 | 645.0 |
|---|-------|-------|-------|-------|-------|-------|--------|--------|
| Vibration Amp. at Flywheel | | | | | | | | |
| Inboard | 9.7 | 9.7 | 9.7 | 9.1 | 9.1 | 9.7 | 9.7 | 9.7 |
| Outboard | 6.5 | 6.5 | 6.5 | 5.7 | 6.5 | 6.5 | 5.7 | 5.7 |
| Bearings - g's | | | | | | | | |
| (1) Flywheel Speed at Full Motoring - RPM | 52000 | 52000 | 52000 | 52000 | 52000 | 52000 | 52000 | 52000 |
| (2) Minimum Speed Attain Under Load - RPM | 49000 | 49000 | 49000 | 49000 | 49000 | 49000 | 49000 | 49000 |
| Total No. of Simulated Aircraft Flights | 121 | 122 | 123 | 124 | 125 | 126 | 127 | 128 |
| Total No. of Basic Duty Cycle Repetitions | 5908 | 5956 | 6004 | 6052 | 6100 | 6148 | 6196 | 6244 |
| NO. TEMPERATURE DATA - DEG. F | | | | | | | | |
| 1 Test Pump Inlet | 180 | 105 | 85 | 82 | 88 | 100 | 90 | 88 |
| 2 Test Pump Return | 113 | 115 | 96 | 93 | 98 | 102 | 100 | 98 |
| 3 Test Pump Case Drain | 160 | 160 | 148 | 143 | 147 | 148 | 145 | 145 |
| 4 Main Hyd. Reservoir Supply | 100 | 105 | 85 | 82 | 90 | 85 | 90 | 88 |
| 5 Lube Oil Return | 160 | 160 | 152 | 153 | 152 | 160 | 160 | 160 |
| 6 Lube Oil Suction | 100 | 105 | 90 | 88 | 90 | 87 | 90 | 90 |
| 7 Scavange Oil Return | 135 | 135 | 125 | 123 | 128 | 125 | 130 | 127 |
| 8 Gear Box Bearing Adjacent Pump | 175 | 175 | 172 | 170 | 170 | 170 | 170 | 165 |
| 9 Gear Box Bearing Adjacent Flywheel | 175 | 175 | 172 | 170 | 170 | 170 | 170 | 165 |
| 10 Inboard Flywheel Bearing | 175 | 170 | 165 | 163 | 165 | 168 | 168 | 160 |
| 11 Outboard Flywheel Bearing | 160 | 145 | 150 | 148 | 145 | 150 | 155 | 153 |
| 12 Flywheel Case Housing | 155 | 120 | 145 | 148 | 140 | 135 | 145 | 140 |
| NO. SYSTEM PRESSURE DATA - PSIG | | | | | | | | |
| 13 Outboard Flywheel Bearing | 34 | 35 | 35 | 35 | 35 | 35 | 34 | 34 |
| 14 Inboard Flywheel Bearing | 34 | 35 | 35 | 35 | 35 | 35 | 34 | 34 |
| 15 Lube Pump Pressure Port | 54 | 56 | 57 | 57 | 57 | 56 | 56 | 56 |
| 16 Lube Reservoir | 0 | 0 | 0 | 0 | 0 | 0 | 0 | 0 |
| 17 Hyd Supply Pump Press. Port | 3350 | 3350 | 3350 | 3350 | 3350 | 3350 | 3350 | 3350 |
| 18 Test Motor Press. Port (Motoring) | 3300 | 3300 | 3300 | 3300 | 3300 | 3300 | 3300 | 3300 |
| 19 Test Motor Return Port (Motoring) | 120 | 120 | 120 | 120 | 120 | 120 | 120 | 125 |
| 20 Test Pump Press. Range (Pumping) | 1850 | 1850 | 1850 | 1850 | 1850 | 1850 | 1850 | 1850 |
| 21 Test Pump Suction Press. (Pumping) | 210 | 210 | 210 | 210 | 210 | 210 | 210 | 210 |
| 22 Test Motor - Pump Case Drain | 120 | 120 | 120 | 120 | 120 | 120 | 120 | 120 |
| 23 Pressure at Flywheel Tip - CM Hg Ab. | 3.3 | 2.1 | 2.1 | 2.1 | 2.2 | 2.2 | 2.2 | 2.2 |
| NO. FLUID FLOW DATA - GPM | | | | | | | | |
| 24 Inlet Flow to Meter | 16.0 | 16.0 | 16.0 | 16.0 | 16.0 | 16.0 | 16.0 | 16.0 |
| 25 Motor-Pump Case Drain Flow | 0.70 | 0.70 | 0.70 | 0.65 | 0.70 | 0.65 | 0.69 | 0.65 |
| 26 A.P.U. Flow Rate | 23 | 23 | 23 | 23 | 23 | 23 | 23 | 23 |
| 27 Combined A.P.U. & Test Pump Flow (Max) | 36.0 | 36.0 | 36.1 | 36.0 | 36.0 | 36.0 | 36.1 | 36.1 |
| 28 Test Pump Flow Rate - Range | 0-13 | 0-13 | 0-13 | 0-13 | 0-13 | 0-13 | 0-13.1 | 0-13.1 |
| 29 Outboard Bearing Lube Flow - cc/min | 770 | 775 | 775 | 775 | 775 | 775 | 770 | 770 |
| 30 Inboard Bearing Lube Flow - cc/min | 830 | 835 | 835 | 835 | 835 | 835 | 830 | 830 |

* Changed MIL-L-7808 Lube Oil at 614 hours of testing. This improved system vacuum from 3.3 cm. ab. to 2.1 cm. ab.

Table XVIII (Continued)

CONTINUOUS DUTY CYCLE TEST DATA

SUMMARY DATA SHEET NO: 29

DATE: 10-16-67

| Running Time of Test - Hours | | 1139.0 | 1144.0 | 1149.0 | 1154.0 | 1159.0 | 1164.0 | 1169.0 | 1174.0 |
|---|--|--------------|--------------|--------------|--------------|--------------|--------------|--------------|--------------|
| Vibration Amp. at Flywheel | Inboard | 7.3 | 9.7 | 9.1 | 7.9 | 8.5 | 8.9 | 10.1 | 9.1 |
| | Outboard | 3.3 | - | 5.8 | 5.5 | 3.7 | 3.9 | 7.3 | 4.5 |
| Bearings - g's | | | | | | | | | |
| (1) Flywheel Speed at Full Motoring - RPM | | 52,100 | 52,000 | 52,000 | 52,000 | 52,000 | 52,000 | 52,150 | 52,000 |
| (2) Minimum Speed Attain Under Load - RPM | | 48,500 | 48,500 | 48,500 | 48,500 | 48,500 | 48,500 | 48,500 | 48,500 |
| Total No. of Simulated Aircraft Flights | | 225 | 226 | 227 | 228 | 229 | 230 | 231 | 232 |
| Total No. of Basic Duty Cycle Repetitions | | 10,800 | 10,848 | 10,896 | 10,944 | 10,992 | 11,040 | 11,088 | 11,136 |
| NO. TEMPERATURE DATA - DEG. F | | | | | | | | | |
| 1 | Test Pump Inlet | 89 | 95 | 100 | 100 | 93 | 90 | 100 | 92 |
| 2 | Test Pump Return | 89 | 95 | 100 | 100 | 93 | 90 | 100 | 92 |
| 3 | Test Pump Case Drain | 148 | 152 | 142 | 148 | 148 | 150 | 145 | 145 |
| 4 | Main Hyd. Reservoir Supply | 80 | 88 | 80 | 82 | 83 | 83 | 80 | 78 |
| 5 | Lube Oil Return | 158 | 170 | 163 | 160 | 158 | 170 | 152 | 155 |
| 6 | Lube Oil Suction | 85 | 95 | 81 | 88 | 88 | 93 | 80 | 80 |
| 7 | Scavange Oil Return | 120 | 132 | 128 | 130 | 128 | 133 | 112 | 122 |
| 8 | Gear Box Bearing Adjacent Pump | 175 | 188 | 172 | 180 | 185 | 191 | 171 | 180 |
| 9 | Gear Box Bearing Adjacent Flywheel | 170 | 188 | 172 | 180 | 185 | 191 | 171 | 180 |
| 10 | Inboard Flywheel Bearing | 122 | 175 | 161 | 160 | 159 | 170 | 152 | 160 |
| 11 | Outboard Flywheel Bearing | 150 | 165 | 152 | 152 | 150 | 163 | 159 | 150 |
| 12 | Flywheel Case Housing | 103 | 142 | 108 | 102 | 100 | 112 | 112 | 110 |
| NO. SYSTEM PRESSURE DATA - PSIG | | | | | | | | | |
| 13 | Outboard Flywheel Bearing | 33 | 35 | 34 | 34 | 34 | 36 | 34 | 35 |
| 14 | Inboard Flywheel Bearing | 34 | 35 | 34 | 34 | 35 | 34 | 33 | 35 |
| 15 | Lube Pump Pressure Port | 56 | 57 | 58 | 57 | 58 | 58 | 59 | 59 |
| 16 | Lube Reservoir | 0 | 0 | 0 | 0 | 0 | 0 | 0 | 0 |
| 17 | Hyd Supply Pump Press. Port | 3350 | 3350 | 3350 | 3350 | 3350 | 3350 | 3350 | 3350 |
| 18 | Test Motor Press. Port (Motoring) | 3300 | 3300 | 3300 | 3300 | 3300 | 3300 | 3300 | 3300 |
| 19 | Test Motor Return Port (Motoring) | 115 | 115 | 115 | 115 | 115 | 115 | 115 | 115 |
| 20 | Test Pump Press. Range (Pumping) | 1450 2450 | 1450 2450 | 1450 2450 | 1450 2450 | 1450 2450 | 1450 2450 | 1450 2450 | 1450 2450 |
| 21 | Test Pump Suction Press. (Pumping) | 115 200 | 115 200 | 115 200 | 115 200 | 115 200 | 115 200 | 115 200 | 115 200 |
| 22 | Test Motor - Pump Case Drain | 115 200 | 115 200 | 115 200 | 115 200 | 115 200 | 115 200 | 115 200 | 115 200 |
| 23 | Pressure at Flywheel Tip - CM Hg Ab. | 3.0 | 2.0 | 2.1 | 2.1 | 2.2 | 2.3 | 2.2 | 2.3 |
| NO. FLUID FLOW DATA - GPM | | | | | | | | | |
| 24 | Inlet Flow to Meter | 16.1 | 16.1 | 16.1 | 16.1 | 16.1 | 16.1 | 16.1 | 16.1 |
| 25 | Motor-Pump Case Drain Flow | 0.72 | 0.75 | 0.75 | 0.75 | 0.75 | 0.75 | 0.75 | 0.75 |
| 26 | A.P.U. Flow Rate | 23 | 23 | 23 | 23 | 23 | 23 | 23 | 23 |
| 27 | Combined A.P.U. & Test Pump Flow (Max) | 36.1 | 36.1 | 36.1 | 36.1 | 36.0 | 36.0 | 36.0 | 36.0 |
| 28 | Test Pump Flow Rate - Range | 0-13.1 | 0-13.1 | 0-13.1 | 0-13.1 | 0-13 | 0-13 | 0-13 | 0-13 |
| 29 | Outboard Bearing Lube Flow - cc/min | 770 | 790 | 810 | 810 | 810 | 815 | 815 | 790 |
| 30 | Inboard Bearing Lube Flow - cc/min | 860 | 870 | 870 | 870 | 870 | 840 | 870 | 870 |

*Changed MIL-L-7808 lube oil at 1139.0 hours of testing. This improved system vacuum from 3.0 cm. ab. to 2.0 cm. ab.

Table XVIII (Concluded)

CONTINUOUS DUTY CYCLE TEST DATA

SUMMARY DATA SHEET NO: 38DATE: 11-16-67

| | | | | | | | | | |
|---|--|---------------|---------------|---------------|---------------|--|--|--|--|
| Running Time of Test - Hours | | 1499.0 | 1504.0 | 1509.0 | 1514.1 | | | | |
| Vibration Amp. at Flywheel | Inboard | 7.9 | 7.8 | 6.1 | 6.7 | | | | |
| | Outboard | 6.5 | 6.8 | 7.3 | 7.1 | | | | |
| Bearings - g's | | | | | | | | | |
| (1) Flywheel Speed at Full Motoring - RPM | | 52,000 | 52,000 | 52,000 | 52,000 | | | | |
| (2) Minimum Speed Attain Under Load - RPM | | 48,500 | 48,500 | 48,500 | 48,500 | | | | |
| Total No. of Simulated Aircraft Flights | | 297 | 298 | 299 | 300 | | | | |
| Total No. of Basic Duty Cycle Repetitions | | 14256 | 14304 | 14352 | 14400 | | | | |
| TEMPERATURE DATA - DEG. F | | | | | | | | | |
| NO. | | | | | | | | | |
| 1 | Test Pump Inlet | 94 | 92 | 95 | 100 | | | | |
| 2 | Test Pump Return | 94 | 90 | 95 | 100 | | | | |
| 3 | Test Pump Case Drain | 138 | 130 | 138 | 140 | | | | |
| 4 | Main Hyd. Reservoir Supply | 98 | 90 | 85 | 95 | | | | |
| 5 | Lube Oil Return | 155 | 145 | 142 | 125 | | | | |
| 6 | Lube Oil Suction | 80 | 80 | 85 | 90 | | | | |
| 7 | Scavange Oil Return | 120 | 120 | 128 | 125 | | | | |
| 8 | Gear Box Bearing Adjacent Pump | 160 | 160 | 172 | 155 | | | | |
| 9 | Gear Box Bearing Adjacent Flywheel | 165 | 165 | 176 | 170 | | | | |
| 10 | Inboard Flywheel Bearing | 158 | 160 | 160 | 160 | | | | |
| 11 | Outboard Flywheel Bearing | 145 | 140 | 148 | 150 | | | | |
| 12 | Flywheel Case Housing | 132 | 130 | 140 | 125 | | | | |
| SYSTEM PRESSURE DATA - PSIG | | | | | | | | | |
| NO. | | | | | | | | | |
| 13 | Outboard Flywheel Bearing | 36 | 36 | 36 | 36 | | | | |
| 14 | Inboard Flywheel Bearing | 36 | 36 | 36 | 36 | | | | |
| 15 | Lube Pump Pressure Port | 55 | 55 | 56 | 55 | | | | |
| 16 | Lube Reservoir | 0 | 0 | 0 | 0 | | | | |
| 17 | Hyd Supply Pump Press. Port | 3350 | 3350 | 3350 | 3350 | | | | |
| 18 | Test Motor Press. Port (Motoring) | 3300 | 3300 | 3300 | 3300 | | | | |
| 19 | Test Motor Return Port (Motoring) | 125 | 125 | 125 | 125 | | | | |
| 20 | Test Pump Press. Range (Pumping) | 1450 2450 | 1450 2450 | 1450 2450 | 1450 2450 | | | | |
| 21 | Test Pump Suction Press. (Pumping) | 200 | 200 | 200 | 200 | | | | |
| 22 | Test Motor - Pump Case Drain | 125 200 | 125 200 | 125 200 | 125 200 | | | | |
| 23 | Pressure at Flywheel Tip - CM Hg Ab. | 2.7 | 2.7 | 2.7 | 2.8 | | | | |
| FLUID FLOW DATA - GPM | | | | | | | | | |
| NO. | | | | | | | | | |
| 24 | Inlet Flow to Meter | 16.6 | 16.6 | 16.6 | 16.6 | | | | |
| 25 | Motor-Pump Case Drain Flow | 0.75 | 0.70 | 0.75 | 0.75 | | | | |
| 26 | A.P.U. Flow Rate | 23 | 23 | 23 | 23 | | | | |
| 27 | Combined A.P.U. & Test Pump Flow (Max) | 35.9 | 35.9 | 35.8 | 35.9 | | | | |
| 28 | Test Pump Flow Rate - Range | 0-12.90-12.90 | 0-12.90-12.90 | 0-12.80-12.80 | 0-12.90-12.90 | | | | |
| 29 | Outboard Bearing Lube Flow - cc/min | 828 | 828 | 828 | 828 | | | | |
| 30 | Inboard Bearing Lube Flow - cc/min | 880 | 880 | 880 | 880 | | | | |

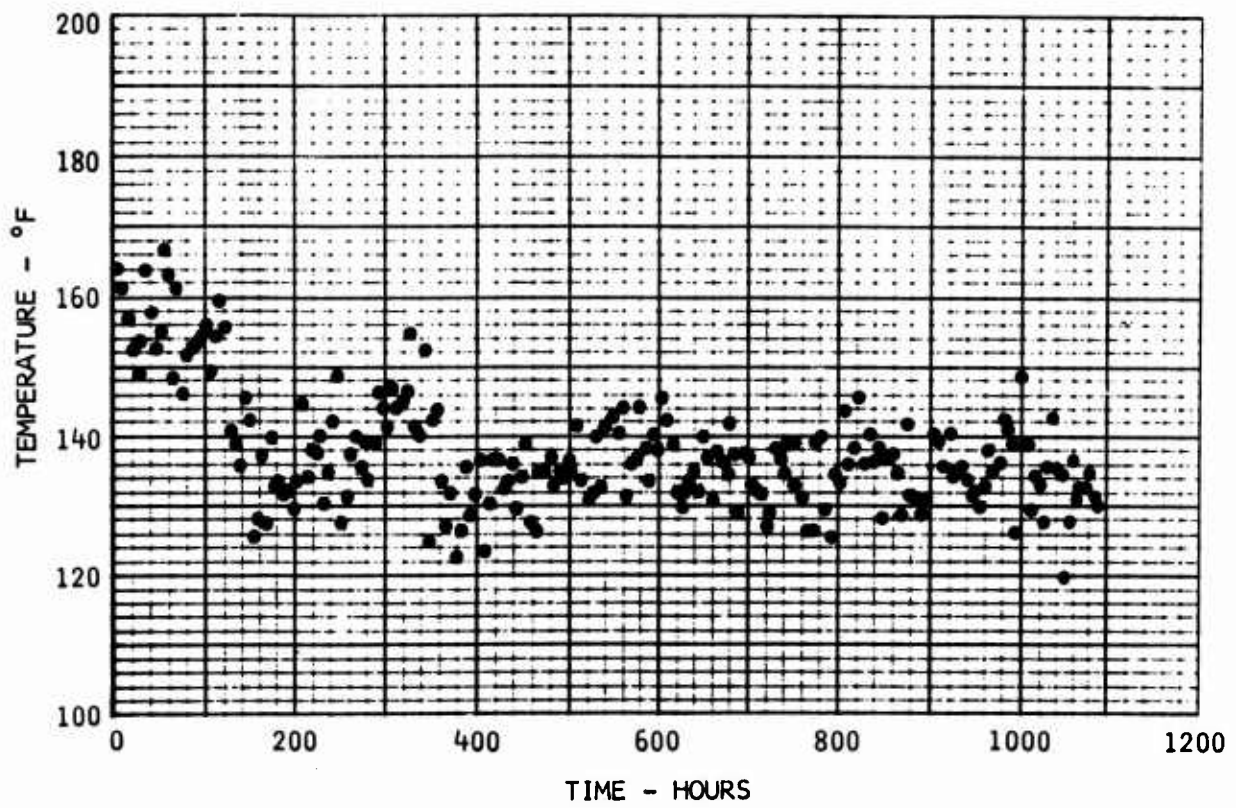

Figure 48. Average Substation Temperature

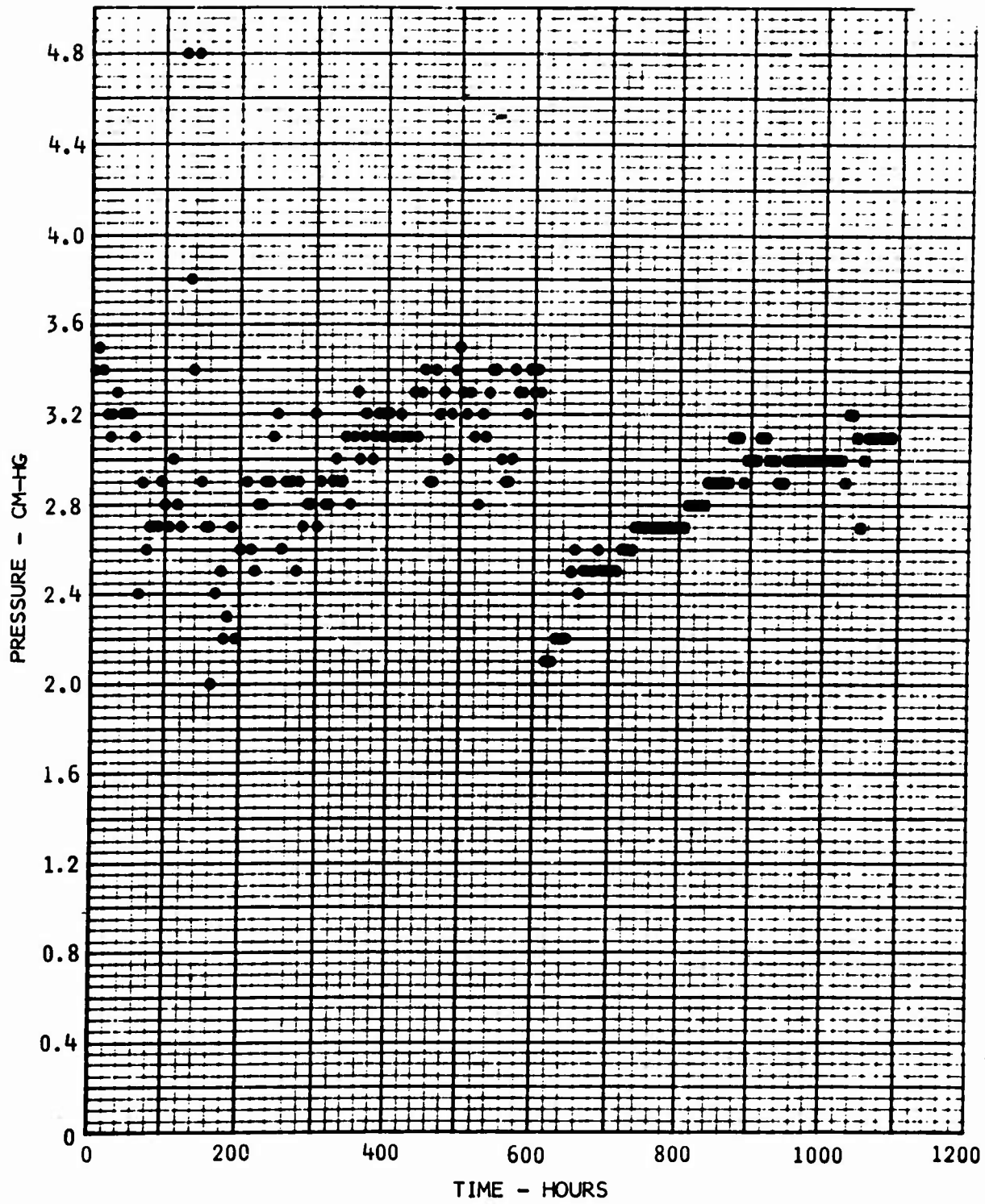

Figure 49. Flywheel Absolute Pressure

All gear tooth faces were in perfect condition as well as all of the bearings. The only parts replaced in the gearbox upon reassembly consisted of replacing the seals as a precautionary measure. There was some sign of fretting corrosion at the gearbox end of the flywheel to gearbox quill shaft. However, there was no explanation for the peculiar contaminant.

The flywheel was then disassembled for lack of other failure evidence. The source of the peculiar contaminant became readily apparent when several drops of mercury were found in the flywheel housing. It is believed that mercury came from the manometer used to measure absolute vacuum.

The carbon seal faces were worn, one more badly than the other. The mating ring which was paired with the more seriously worn seal had a radial scratch across the sealing area. The scratch probably occurred during assembly. It caused scoring of the carbon seal face and led to the early leakage failure.

The tip of the flywheel was discolored from heat and it is estimated that a temperature in excess of 600° F was reached. A surface hardness test indicated that the tensile strength dropped from 260 to 210 ksi for the outer 1/2-inch of the periphery. (This was not considered to impair the strength of the flywheel, since the outer edge has about a 20 percent lesser stress than the center of the flywheel.)

In addition, but not related to the above, a flywheel support bearing was found to have a cracked separator ring.

Microscopic examination of the patch taken from the lubricating oil later disclosed that the metallic particles were about 90 percent mercury.

A complete replacement of the lubrication oil was made as well as the washing and flushing of all tubes, components, and passages which had contact with the oil. A separate recirculating filter system was also connected to the oil reservoir, and was operated on a continuous 24-hour-a-day basis.

In the interim, while the Number 1 energy storage substation was being refurbished, the Number 2 substation was installed on the simulator. It operated satisfactorily for 48.9 hours except in one respect. The vacuum would fluctuate between two relatively fixed levels (i.e., 5.2 and 2.8 centimeters of mercury absolute). During flight number 35, a runaway temperature condition was detected at the flywheel housing, that resembled the condition noted during flight number 26 except of lesser magnitude.

Testing of the Number 2 substation was stopped and investigation of the condition revealed that failure of the rotary seals had allowed oil to enter the housing. There was no discoloration of the flywheel. It is believed that this failure and the previous one were identical except for the fact that, in the first case, mercury had been allowed to accumulate and was subsequently drawn into the housing, from the vacuum instrumentation line. It was felt that the 600° F tip temperature resulted solely from the presence of mercury with its high density and associated high drag losses and that these temperatures will not be reached in the presence of oil.

Refurbishment of this flywheel revealed that the sealing faces of both seals were in generally satisfactory condition. However, one of the dynamic seals was noted to have lost much of its ability to return the carbon face to an extended position upon being depressed slightly beyond the installed position. Two possible causes were investigated: one was an improper installation procedure wherein the spring was overstressed; the other was a degradation of the O-ring seal by swelling. Investigation revealed the probabilities were that the seal housing had been deformed axially during assembly and the seal spring overstressed. In any event the "sticky" action of the seal was believed to be the cause for the erratic performance of the vacuum system.

A change was incorporated in the vacuum instrumentation wherein the test was continuously monitored by a Bourdon-type vacuum gage. The mercury column manometer was used momentarily only once per flight to obtain an accurate reading. This was done to avoid a repetition of the mercury filling incident.

From the time of the reinstallation of energy storage substation Number 1, at 174.2 hours of total test time, the simulator operated satisfactorily. However, during one of the shutdown periods the various heat exchangers for the oil systems were cleaned and flushed. This resulted in a considerable improvement in their efficiency, and the energy storage substation operated at generally lower temperatures from that time on.

During the course of operating, it was noted that the vacuum created in the flywheel case slowly degraded. Absolute pressure readings when energy storage substation Number 1 was rebuilt and reinstalled at 174.2 hours were around 2.5 centimeters of mercury. At 614 hours of operation pressure readings had gradually increased to 3.1 centimeters of mercury.

It was discovered, upon making a routine replacement of the MIL-L-7808 lubricating oil, that the vacuum returned to its original condition. It is reasoned from these observations that the improvement was brought about by the effect of increased viscosity of the new oil and its effect upon the sealing characteristics of the vacuum pump gear teeth as well as the rotary shaft seals. The gradual degradation in vacuum level and its sharp recovery upon changing oil can be seen in table XVIII, sheets 5, 10, and 16, as well as in figure 49.

During the repeated duty cycles representing peak energy extraction, the flywheel speed was reduced only 8 percent, and it recovered to threshold regulated speed in only 3 seconds. The flywheel weighed 15 pounds; however, from the above values it is easily recognized that the optimum flywheel would have been considerably smaller and lighter with a larger (10 to 15 percent) speed reduction. Conversely, maintaining the same weight and size, this flywheel would be capable of meeting a larger percentage of the peak power demand, thus making possible further reductions in the basic power generation and distribution system. The system as tested met one third of the peak power demand. With a somewhat larger motor-pump and greater (≈ 15 percent) speed reduction it could supply one half of the peak power demand.

The total test imposed maximum operational times on components as follows:

| | |
|----------------------------------|----------|
| Flywheel | *1,576.6 |
| Gearbox | *1,596.6 |
| Motor-pump | 1,523.6 |
| Rotary carbon seals (52,000 rpm) | 1,339.9 |
| Flywheel support bearings | 1,339.9 |

*Including tilt table test time and various checkout operations

D. DISASSEMBLY AND INSPECTION

Following completion of the endurance test (1,514.1 hours of operation) the energy storage substation was disassembled (see figure 50) and inspected. The condition of the components parts was found to be as follows:

FLYWHEEL HOUSING

The flywheel housing was in excellent condition. However, it contained very minute traces of mercury which was believed to have originated from the absolute pressure manometer used to obtain accurate flywheel evacuated atmospheric pressure data once during each 5-hour flight. (A bourdon tube pressure gage was used for continuous monitoring of the test.) In addition to the mercury, a small amount of black carbon paste, believed to have been worn from the rotary seals was evident near the seal on one side only. The flywheel cavity was otherwise clean and free of all foreign material. It would appear that the minute oil leakage past the carbon seal faces had a washing action and had carried residue into the vacuum pump. A photograph of the disassembled flywheel housing is shown in figure 51.

FLYWHEEL

The flywheel was blackened with oxidized lubricant residue. This coating was sufficiently tough that removal by abrasive rubbing was required to inspect the parent surface of the metal. The metal surface underneath had its original heat treatment oxide coating except for the outer 1-1/2 inches of periphery. The outermost 1/2 inch was blue and the next inward 1/2 inch was purple. From 1 inch inward the color faded from dark straw to the original color when manufactured.

A hardness check indicated that the tensile strength was unchanged since the mercury filling episode which occurred at 125.3 hours. Figure 52 shows the flywheel and the abrasively-cleaned strip.

The before and after measurements of the outer diameter were not recorded for comparison; however, from the fit of the wheel in the housing, no detectable change was observed. It is believed that no growth had occurred, since the balance of the wheel had not displayed any change as of the end of the endurance test.

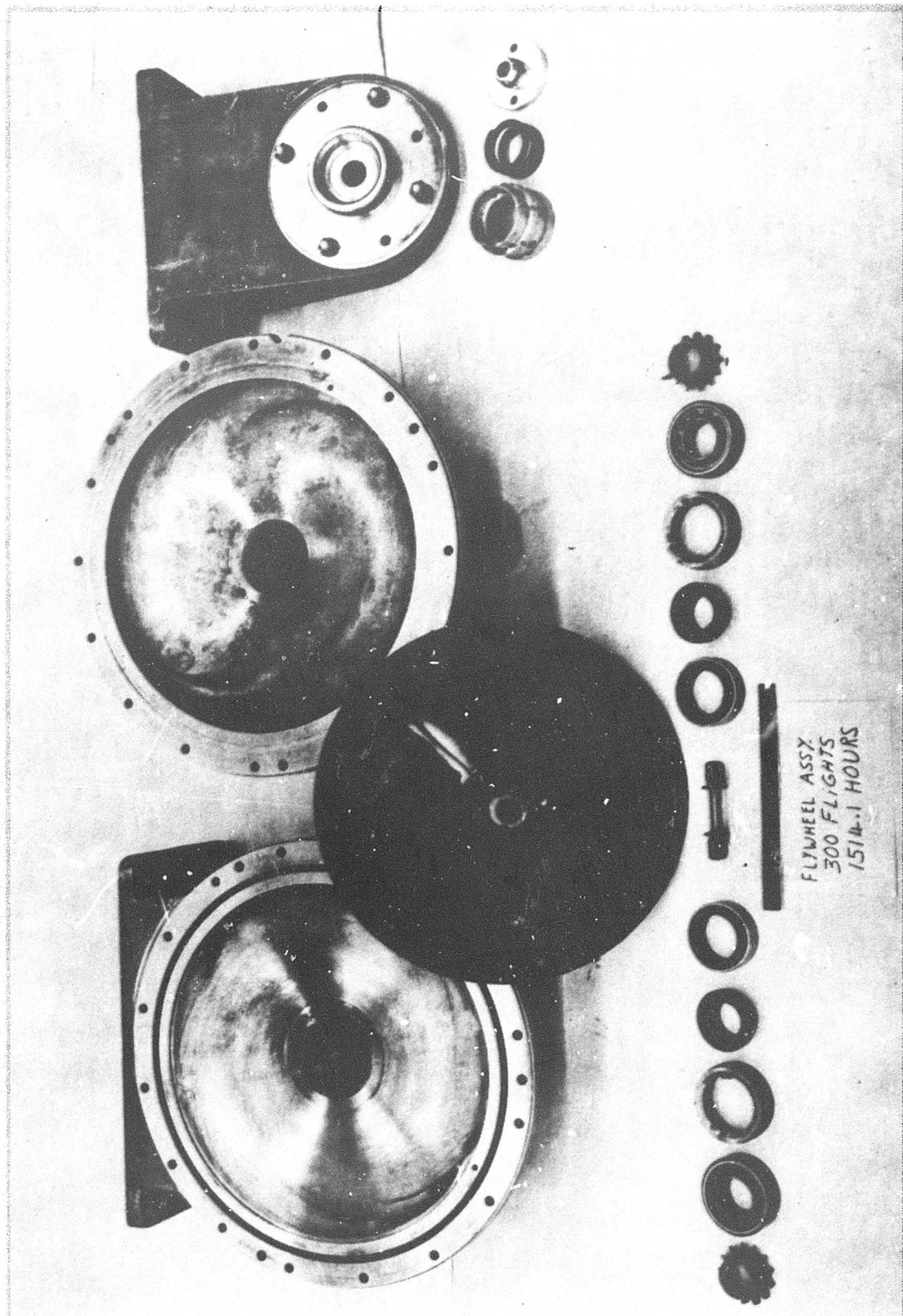

Figure 50. Continuous Duty Endurance Test Flywheel Assembly

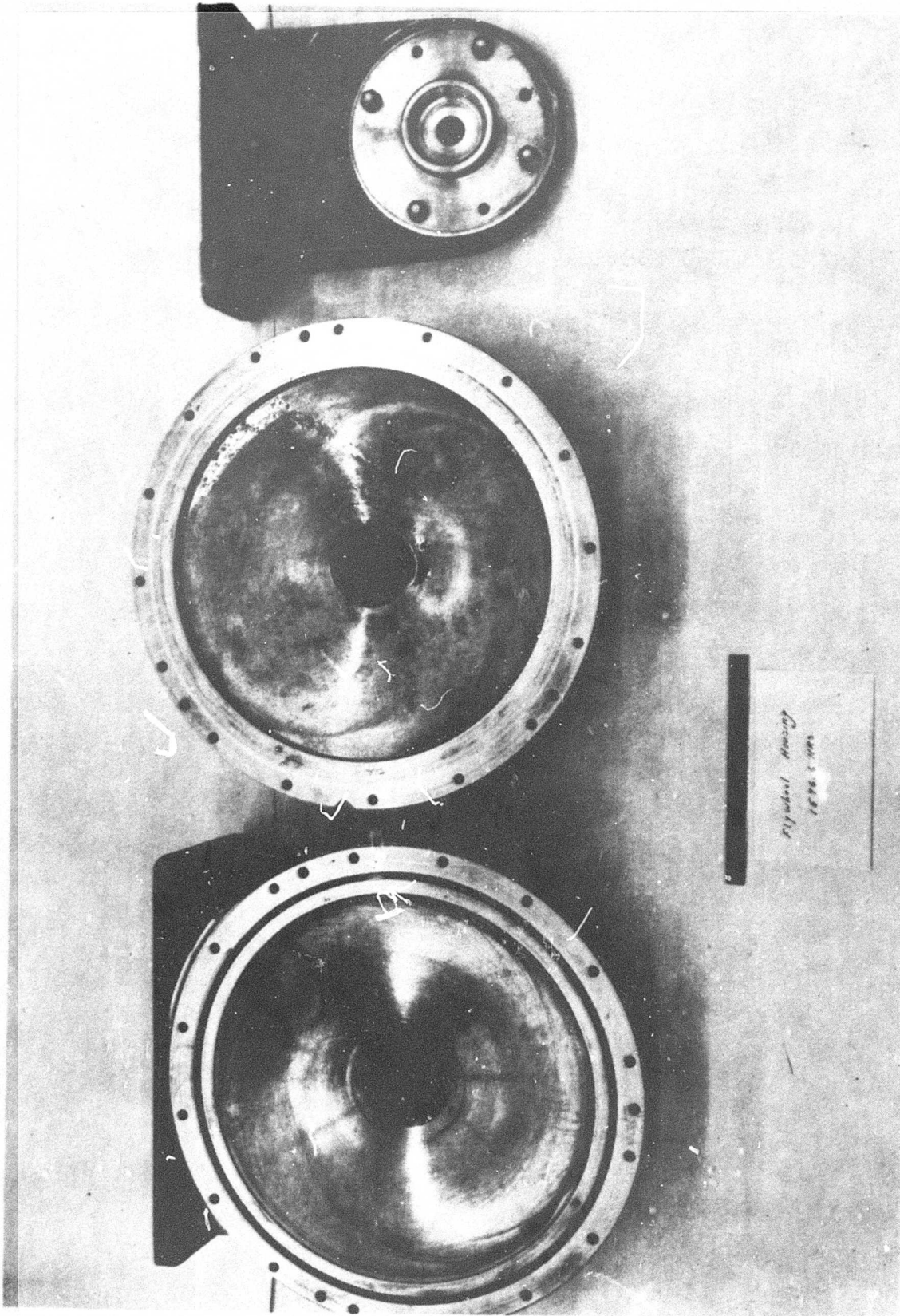

Figure 51. Closeup of Flywheel Housing



Figure 52. Flywheel After Continuous Duty Cycle Endurance Test

CARBON SEALS

The rotary carbon face seals and mating rings were found to be in functioning condition. The spring load of the carbon ring against the mating ring sealing face had not degraded and no appreciable amount of material appeared to have been worn from either part. The mating ring had solid residue, consisting of oxidized lubricant, varnished to its outer edge and on part of the sealing face. No part of either mating ring, however, displayed surface discoloration from metal oxidation. Figure 53 shows the sealing faces of both mating rings. The varnished lubricant can be seen coating the OD surfaces (lubricant side) and the scored grooves can be seen where the carbon seal rode. Inside of this, on the evacuated side, is a windrow of carbonized lubricant.

Although the localized temperature at the point of contact between the two parts was sufficient to decompose some of the lubricant, temperatures generally remained below that which would be necessary to damage elastomeric seals.

The parts (mating ring and carbon seal) were cleaned and inspected for surface finish on a profilometer. The surface condition was as follows:

| | <u>Surface Finish</u> | <u>Groove Depth</u> |
|----------------------|-----------------------|---------------------|
| Inboard mating ring | 20 to 50 RMS | .0005 inch |
| Inboard shaft seal | 20 to 80 RMS | .0005 inch |
| Outboard mating ring | 20 to 90 RMS | .0006 inch |
| Outboard shaft seal | 15 to 90 RMS | .0008 inch |

This roughened surface is believed to have been brought about by foreign particles, including metallic chips and other miscellaneous abrasives, which were introduced into the lubrication system at the time of initial assembly and/or generated during operation.

Apparently the contamination particles worked their way across the sealing faces and initiated the circular score marks. However, due to the ability of the carbon to conform to the convolutions in the mating ring face, leakage characteristics were not seriously affected. The carbon sealing ring is shown in figure 54.

SPLINED QUILL SHAFT

The quill shaft, which interconnects the flywheel and the gearbox pinion, was designed as a symmetrical part. The end which inserts into the flywheel engaged the full length of the mating spline. However, the opposite end, which inserts into the gearbox pinion, engaged only about 80 percent of its spline length due to the configuration of the mating part.

No wear was apparent on the fully engaged spline. However, wear on the other end had removed approximately 50 percent of the teeth cross sections. The female mating part (i.e., the gearbox pinion) displayed about an equal amount of wear. A brown paste wear particle residue typical of

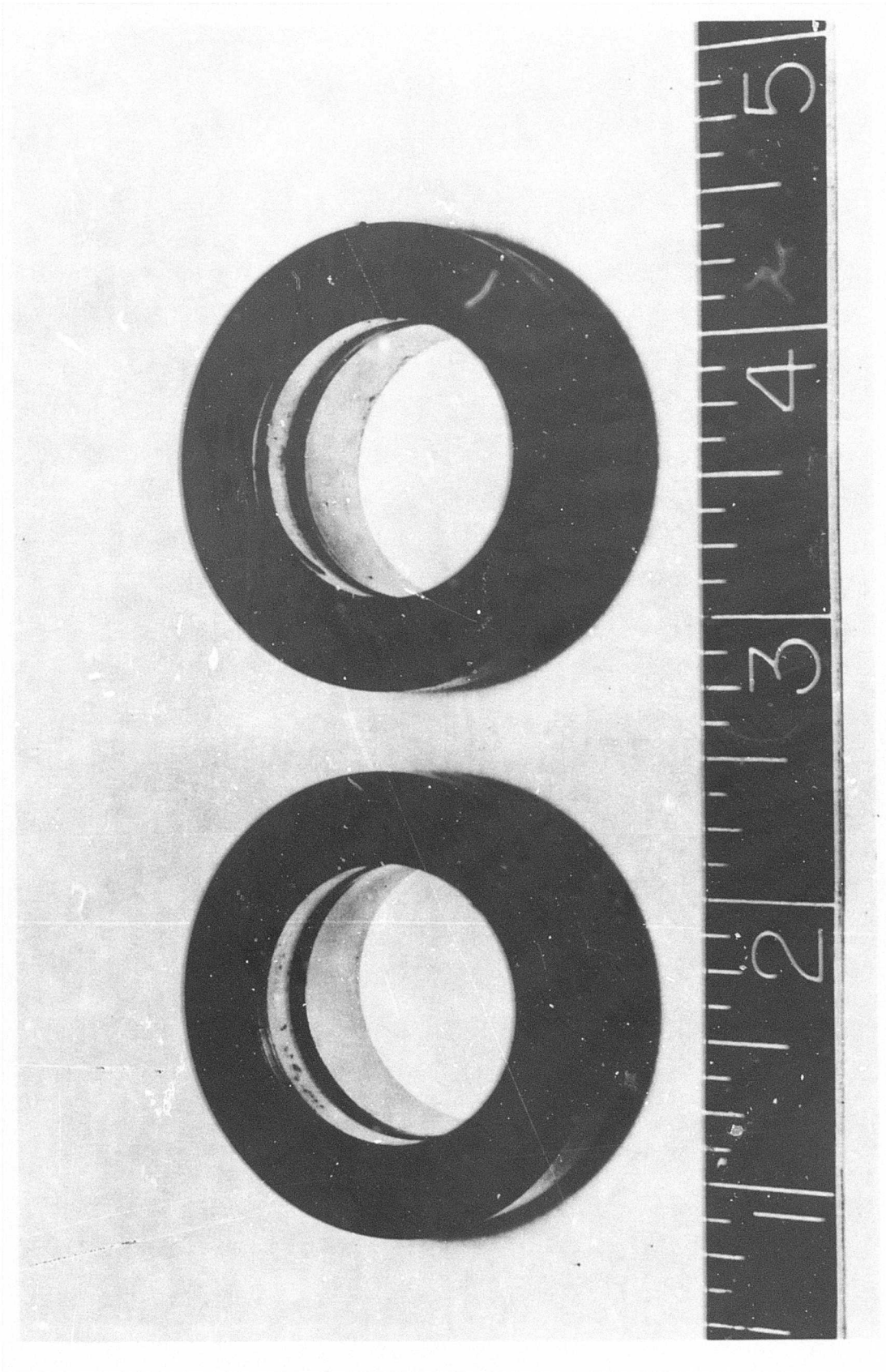

Figure 53. Flywheel Seal Mating Rings (Relapped Prior to 1339.9 Hr Run)

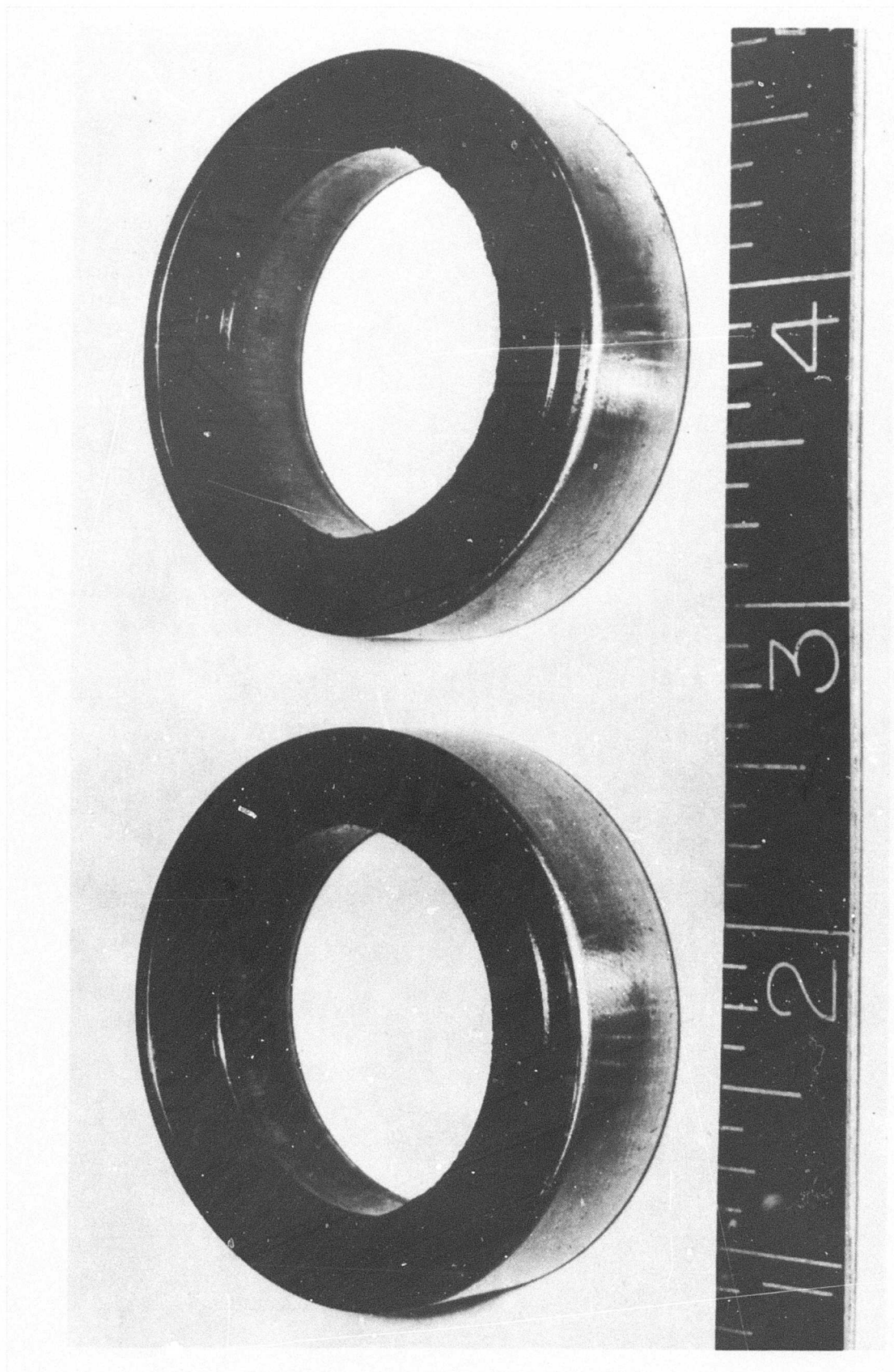

Figure 54. Flywheel Shaft Seal

"fretting corrosion" had built up around the areas of contact. It is estimated that over 70 percent of the spline life had been used up by the test. Both the worn and unworn ends of the quill shaft can be seen in figure 55.

BEARINGS

The flywheel bearings appeared to be in excellent condition. The balls retained their polished brightness. The ball pockets in the retainer showed no signs of elongation or distress. There was no sign of overheating and to all appearances, the lubrication system had performed well. There were some scratches and scuff marks on the balls and the bearings were noticeably rougher than when originally installed. A photograph of both inboard and outboard bearings is shown as figure 56.

GEARBOX

Before disassembly, examination of the gearbox showed that all parts were functioning freely. The gearbox could be hand rotated with noticeably less drag than before the start of the test, and there was no audible sound. The unidirectional brake (overrunning clutch) was also functioning properly.

Disassembly revealed all internal parts to be clean, and there were no visual signs of extraordinary wear except at the service pump group driving shaft. The service pump group is driven at motor-pump speed by a shaft which uses a rectangular key in a slot as a driven spline. The driving sides of the slot were worn to a 30-degree slope. The driven key was worn in a corresponding manner until about one half of the thickness was worn through at the outer edge. However, shearout would probably not have occurred for several thousand hours. The worn key and slot is shown in figure 57.

The completely disassembled gearbox and service pump group is shown in figure 58. It can be seen that the general appearance of all parts ranges from fair to excellent after 1,576.6 hours of operation. A closer view of the gears and their associated bearings, as they would appear looking from the motor-pump side with half of the housing removed, is shown in figure 59. A corresponding view, looking from the other direction, is shown in figure 60.

The motor-pump side view of figure 59 shows that, in spite of the general excellent appearance, certain areas are starting to show signs of distress. These are the motor-pump input spline area and the high speed pinion support bearings. Both of these show signs of overheating.

A closeup of the motor-pump input spline area is shown in figure 61. It can be seen that the shaft seal has started to score the shaft and that the spline area has been overheated. The overheating probably occurred from the combined effects of seal heat generation, spline heat generation, and lack of sufficient lubricant flow in this area to carry the heat away.

Figure 62 is a magnified view of the high speed pinion and one of its support bearings. It can be seen that most of the silverplating is missing from the ball retainer and that both the balls and the retainer are darkened.

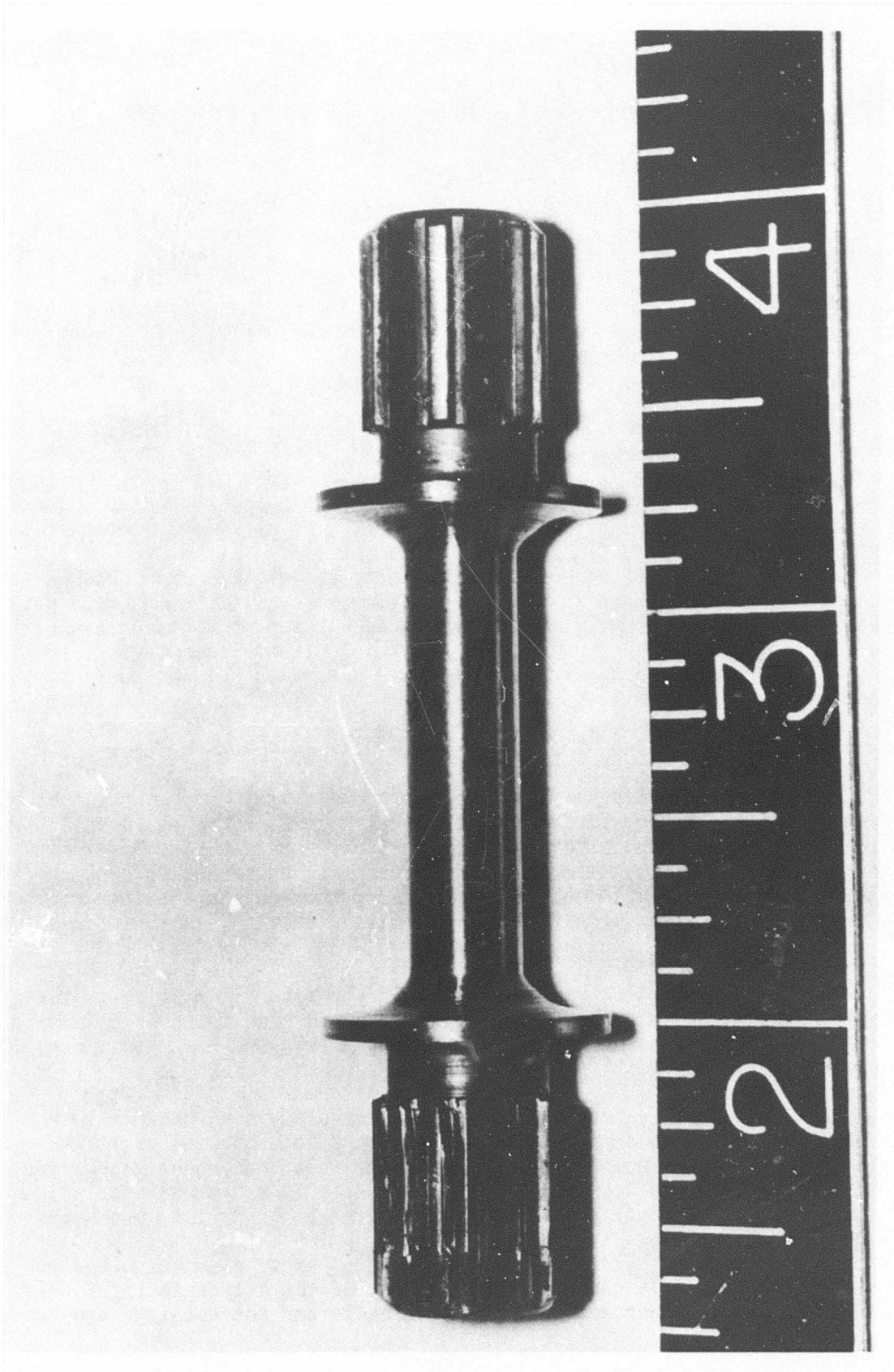

Figure 55. Flywheel - Gearbox Quill Shaft

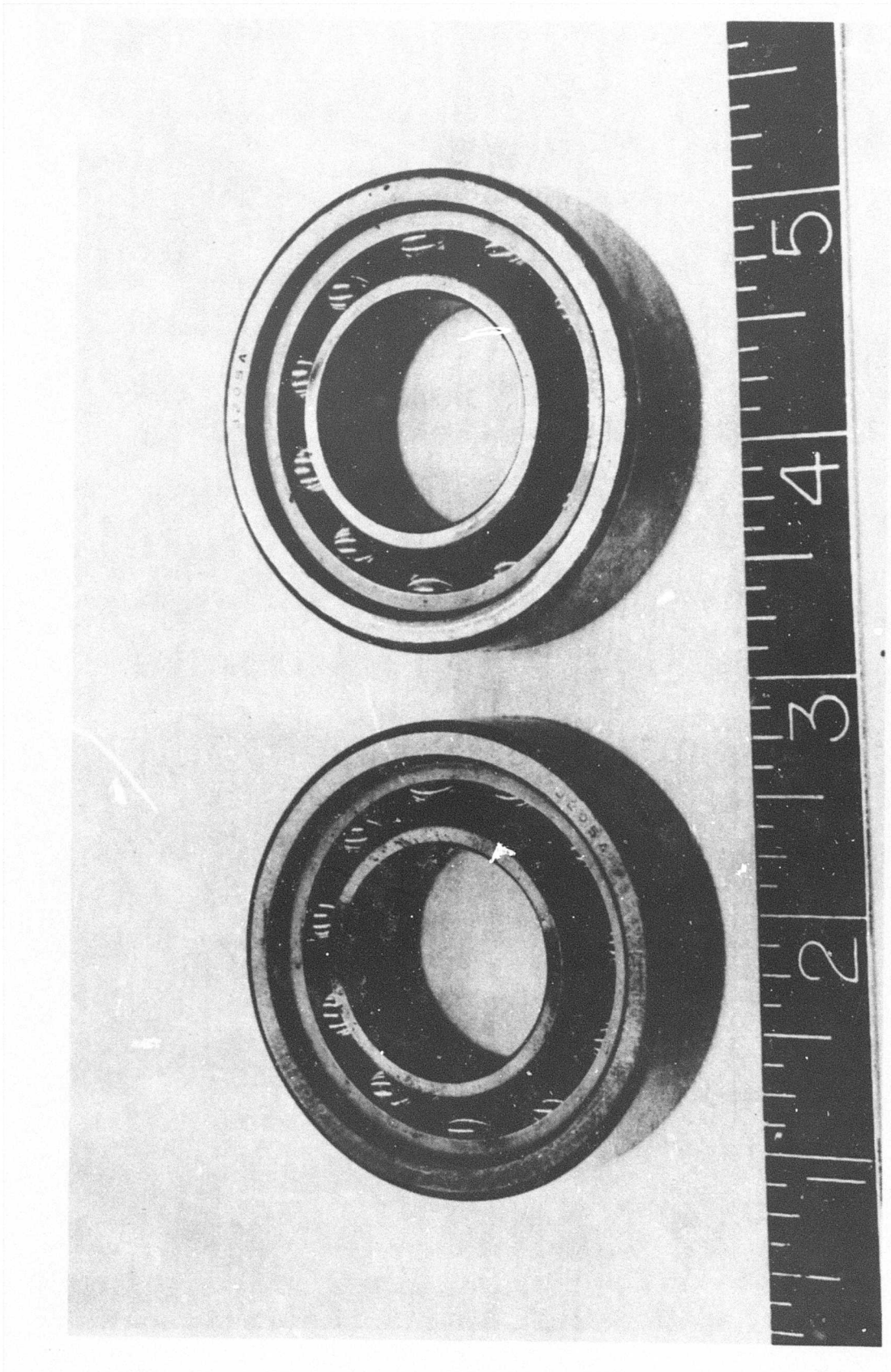

Figure 56. Inboard and Outboard Flywheel Bearings

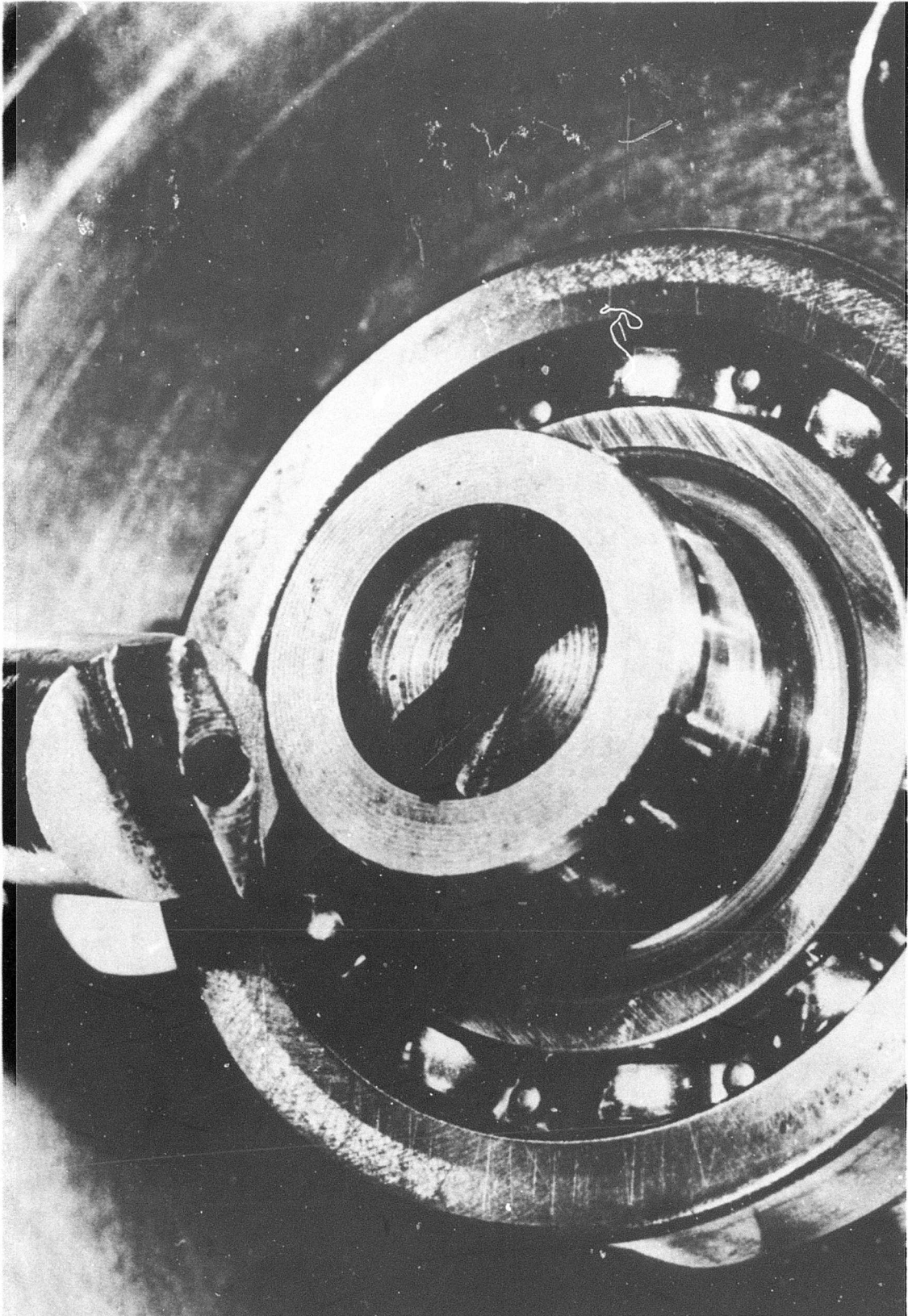

Figure 57. Service Pump Group Drive Wear

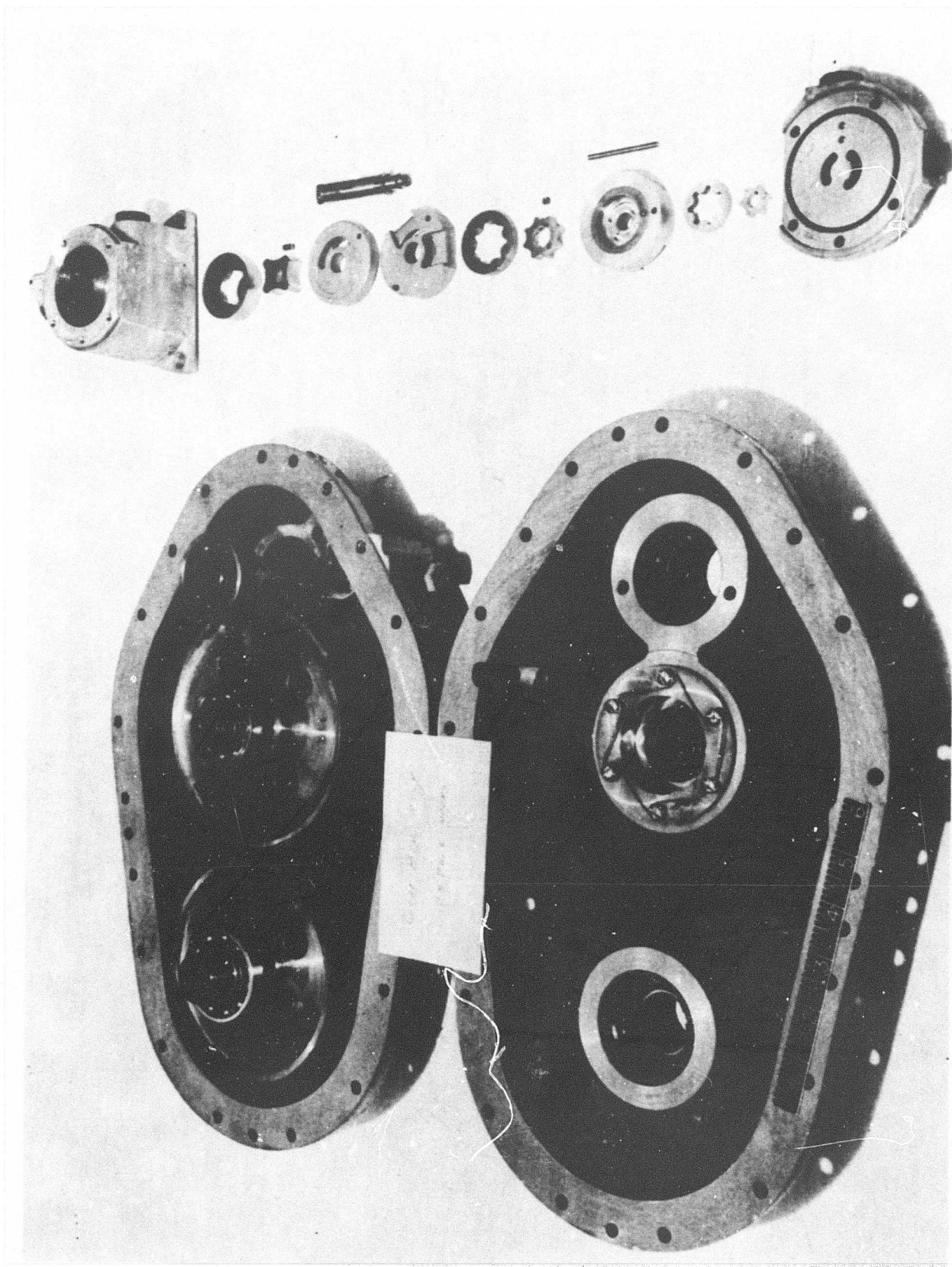
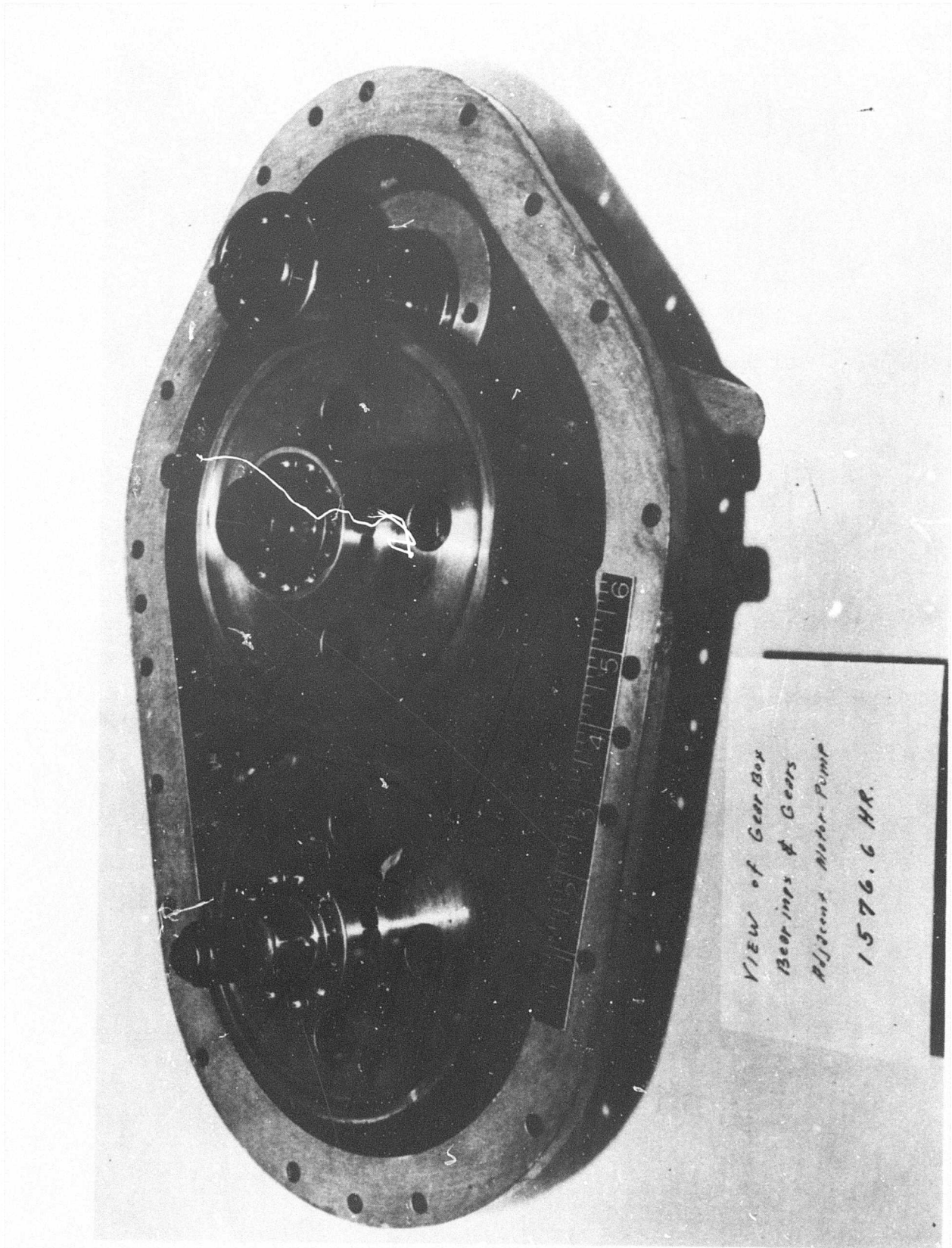

Figure 58. Gearbox and Service Pump Group Disassembled



*VIEW of Gear Box
Bearings & Gears
Adjacent Motor Pump
1576.6 HR.*

Figure 59. View of Gearbox Half From Motor Pump Side

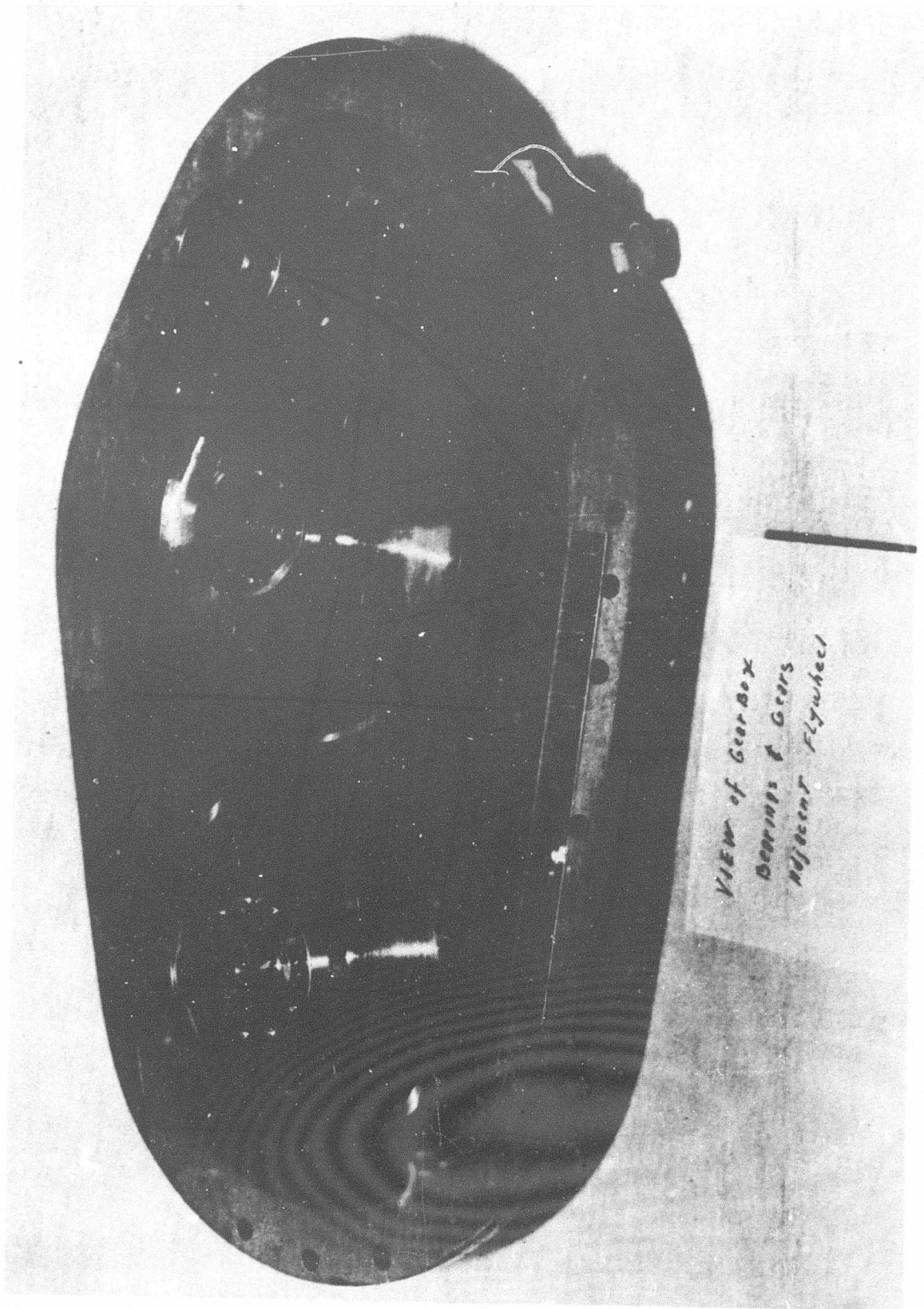

Figure 60. View of Gearbox Half From Flywheel Side

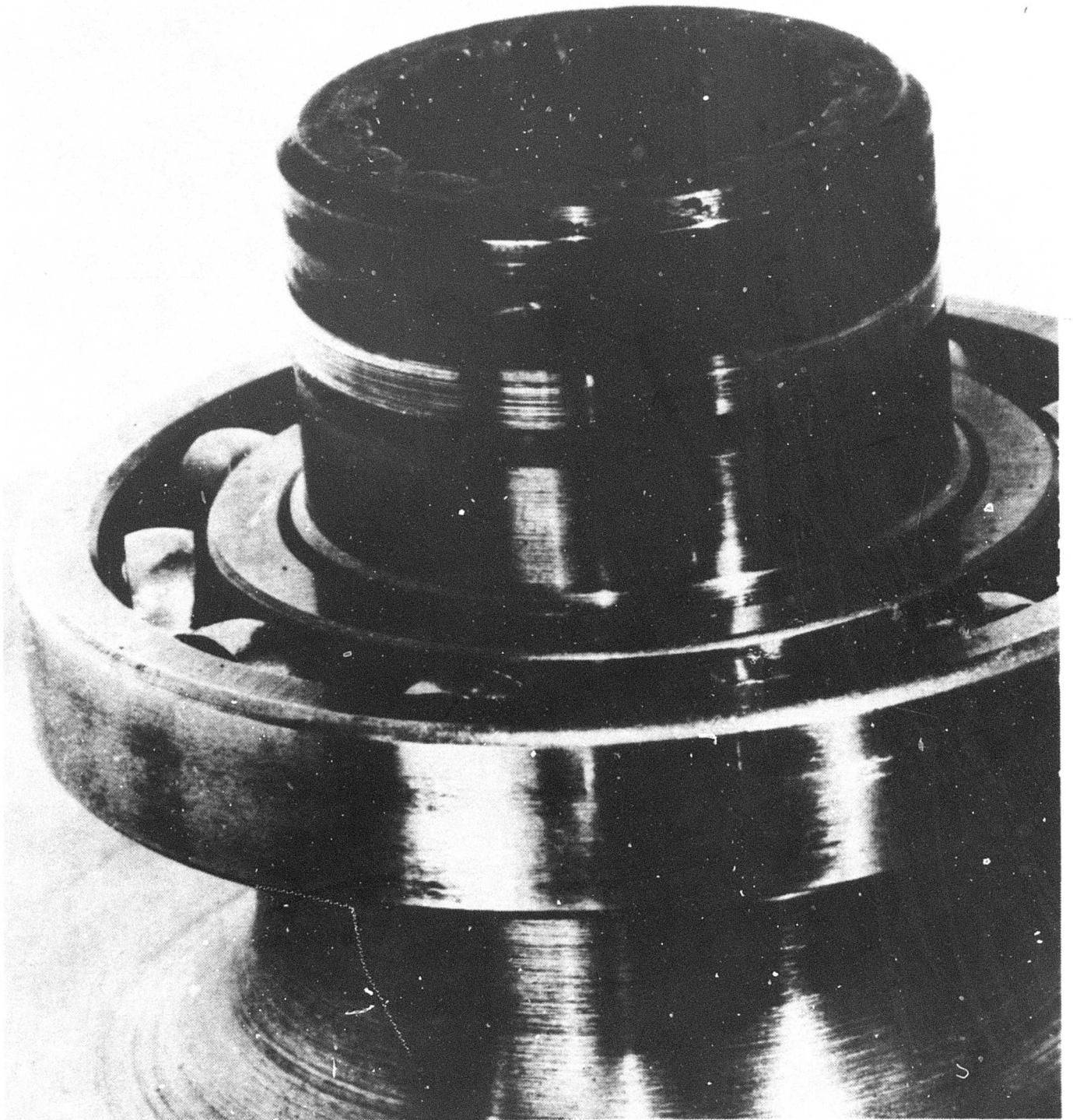

Figure 61. Gearbox Spline - Input From Motor Pump

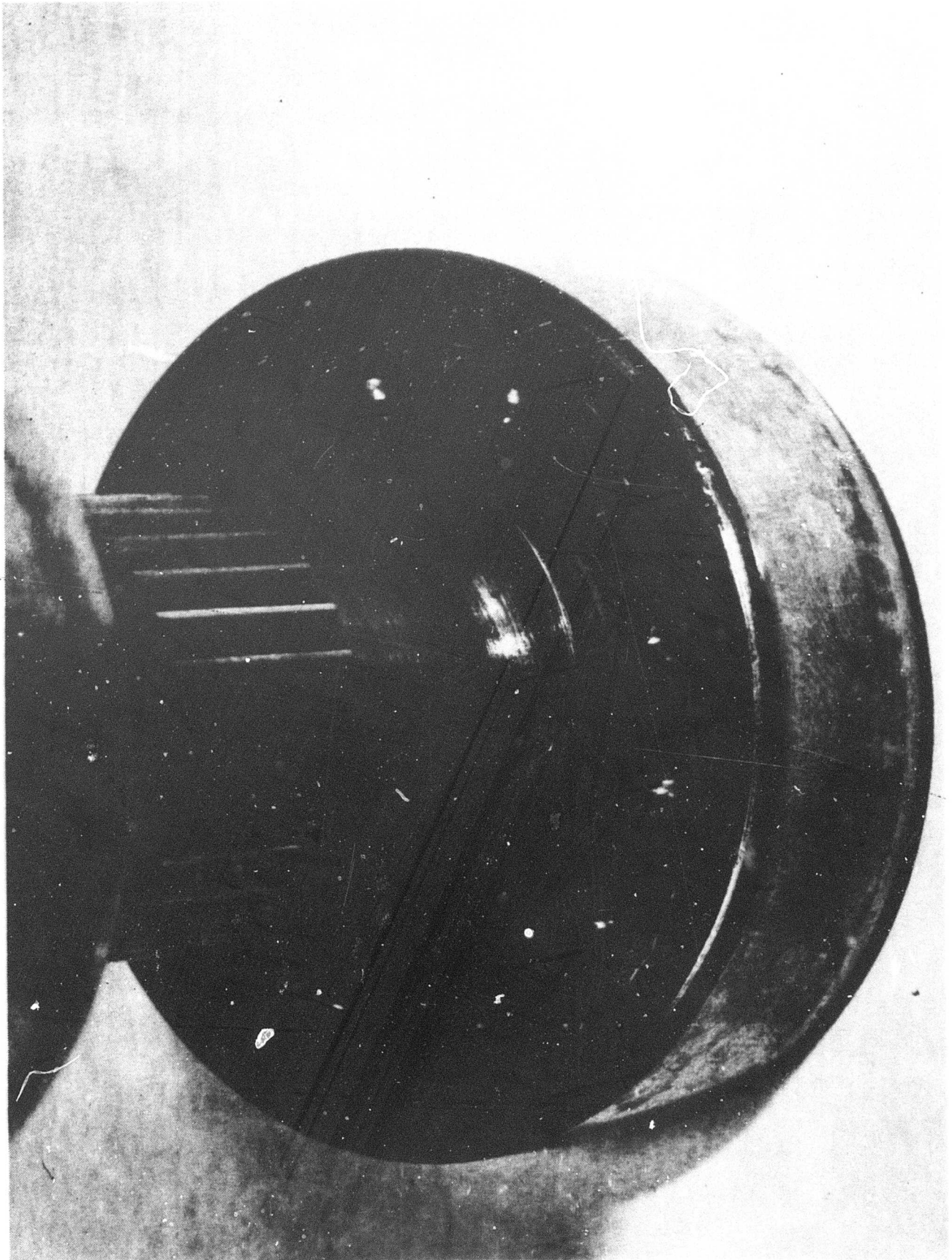

Figure 62. Pinion Gear and Support Bearing

Although it cannot be seen in this photograph, the balls were straw-colored and the ball retainer was blued. This was true of both bearings. In contrast to this, the pinion gear was in excellent condition.

Figure 63 compares the pinion support bearing to an identical flywheel bearing which operated adjacent to it in the flywheel housing at the same speed. The contrast, resulting from heating of the pinion support bearing, is apparent. In most respects the operating conditions for the flywheel bearing were more severe; however, the flywheel bearing was jet lubricated whereas the pinion support bearings were mist lubricated. From this it is apparent that jet lubrication for this type bearing, operating under these conditions, is much to be preferred.

It has already been pointed out that the high speed pinion teeth were in excellent condition. However, both of the larger gears showed signs of distress. Figure 64 is a closeup of the hydraulic motor-pump-driven gear's teeth. The appearance of slight spalling can be seen on the flank of one of the teeth slightly below the center of the picture. Figure 65 is a magnified view of this particular tooth and shows that the spalling is quite widespread. Although a tooth profile reading was not taken, it is believed that the spall depth did not exceed .0004 inch.

All three W. H. Nichols Gerotor pumps in the service pump group were in excellent condition. The disassembled vacuum pump, lube pump, and scavenge pump are shown in that order in figures 66, 67, and 68, respectively.

Visual teardown inspection of the New York Airbrake motor-pump revealed that the unit was in excellent condition considering the 1,523.6 hours of operation under a cyclic pump-motor duty cycle. The disassembled unit is shown in figure 69. The following wear conditions were noted:

1. Upon disassembly the needle bearings used in the wobble plate trunnion were not retained and fell out. The trunnion exhibited some marking from the needle bearings. The needle bearing retention mechanism was missing.
2. Normal valve plate wear, with some cavitation erosion adjacent to the kidney porting V-notch, was evident (see figure 70). Valve plate wear on the mating piston barrel consisted of circumferential grooving of the running surfaces (see figure 71).
3. Slight localized erosion of the slipper (wobble) plate at two points 180 degrees from each other were noted (see figure 72). The shape of this erosion could be matched with the outline of the piston slipper shoes. An enlarged view of the most apparent erosion is shown in figure 73.
4. The mode change mechanism exhibited some abrasive wear at the ball joint which mates with the wobble plate. The nature of the wear is shown in figure 74.

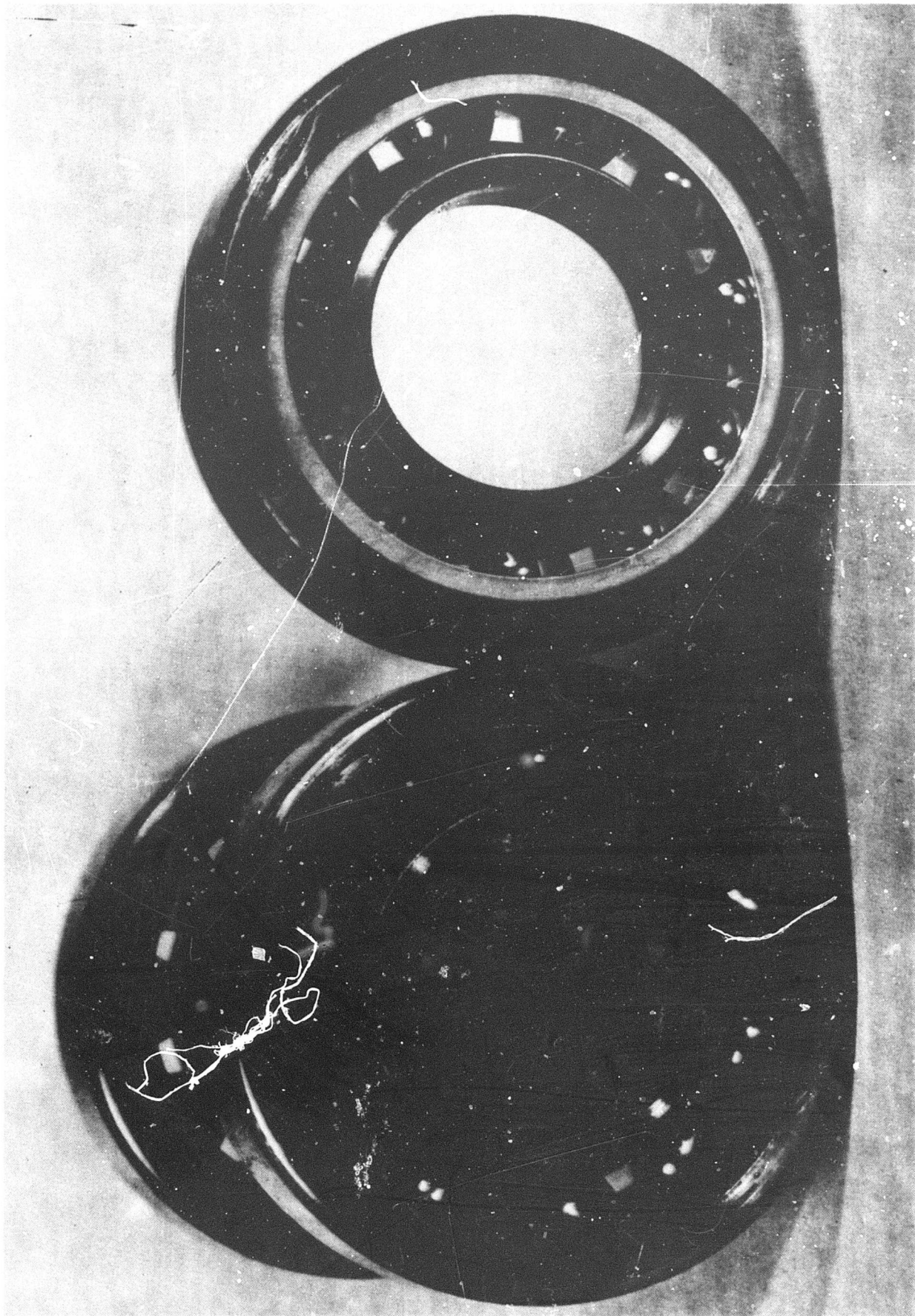

Figure 63. Comparison of High Speed Support Bearings

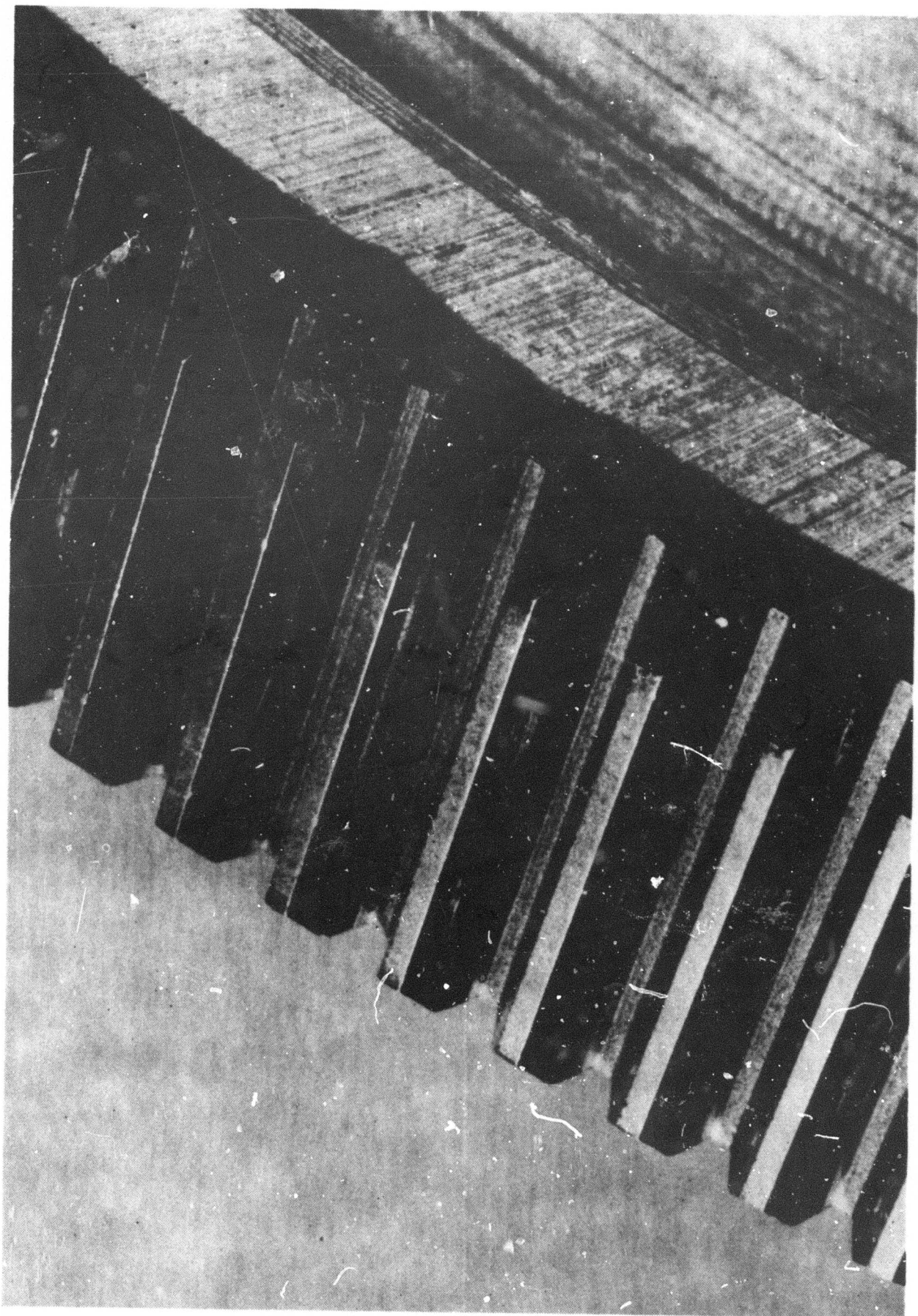

Figure 64. Closeup of Motor-Pump Driven Gear



Figure 65. Motor-Pump Driven Gear Tooth Magnified

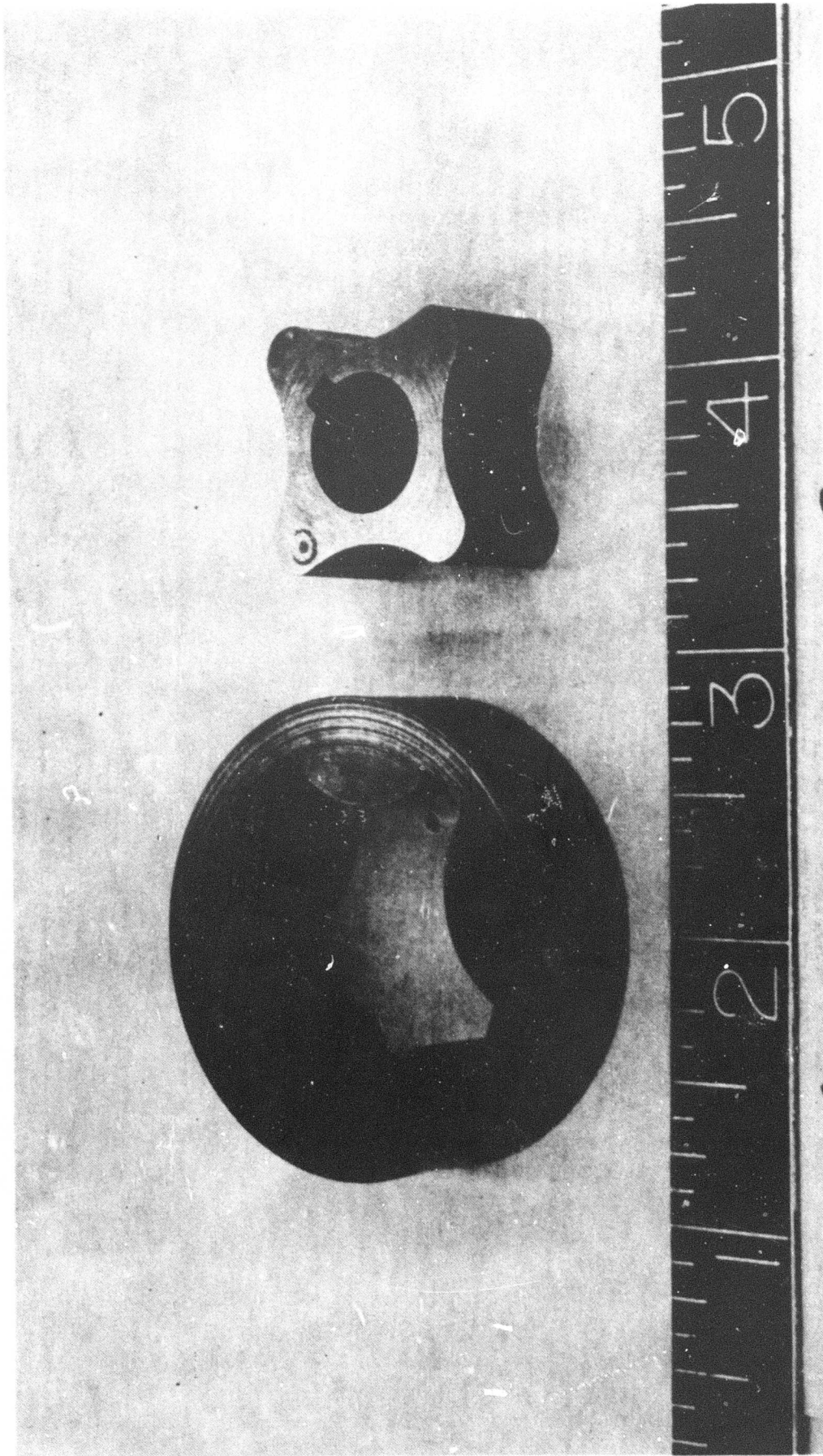

Figure 66. Gerotor Vacuum Pump

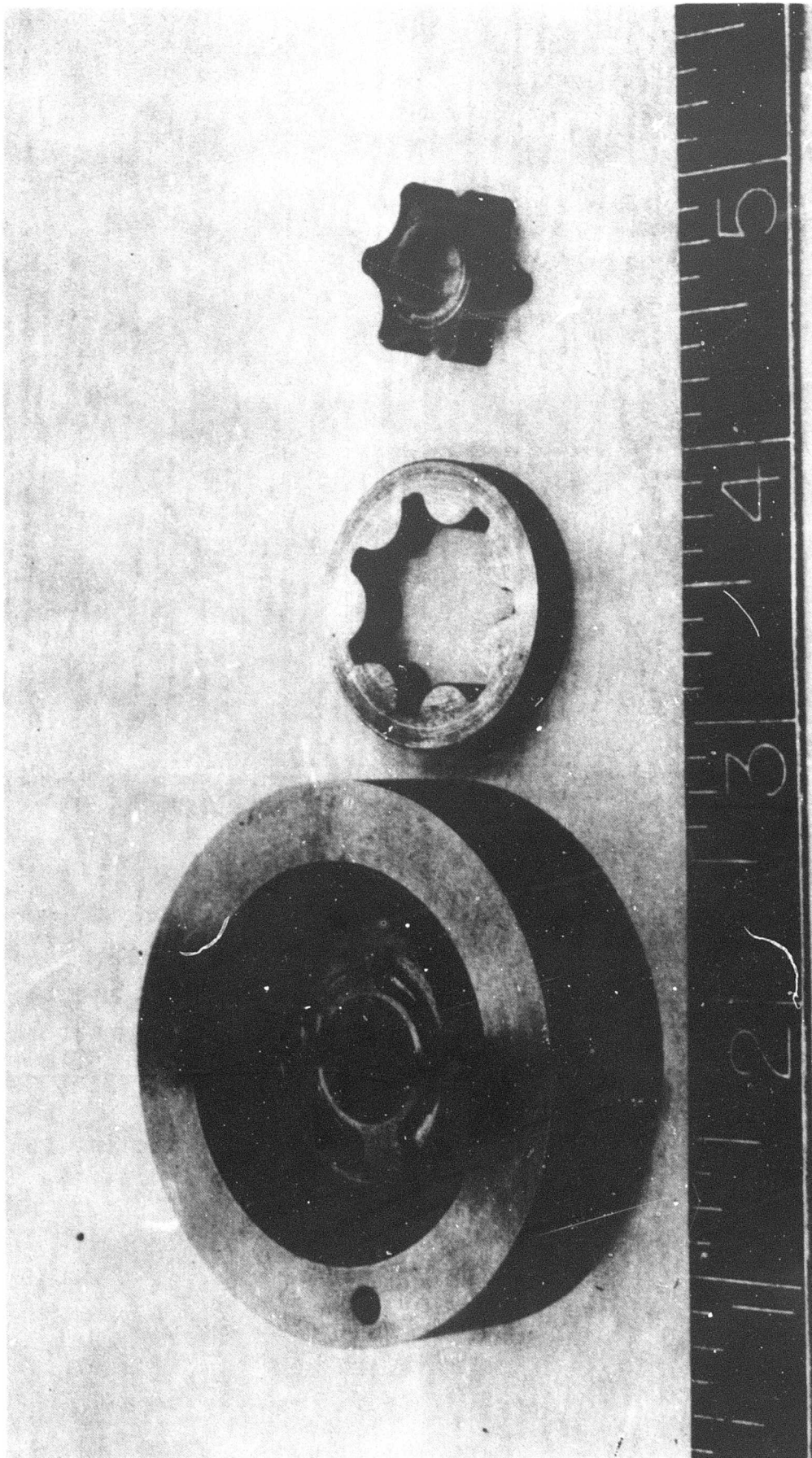

Figure 67. Gerotor Lube Pump



Figure 68. Gerotor Scavenge Pump

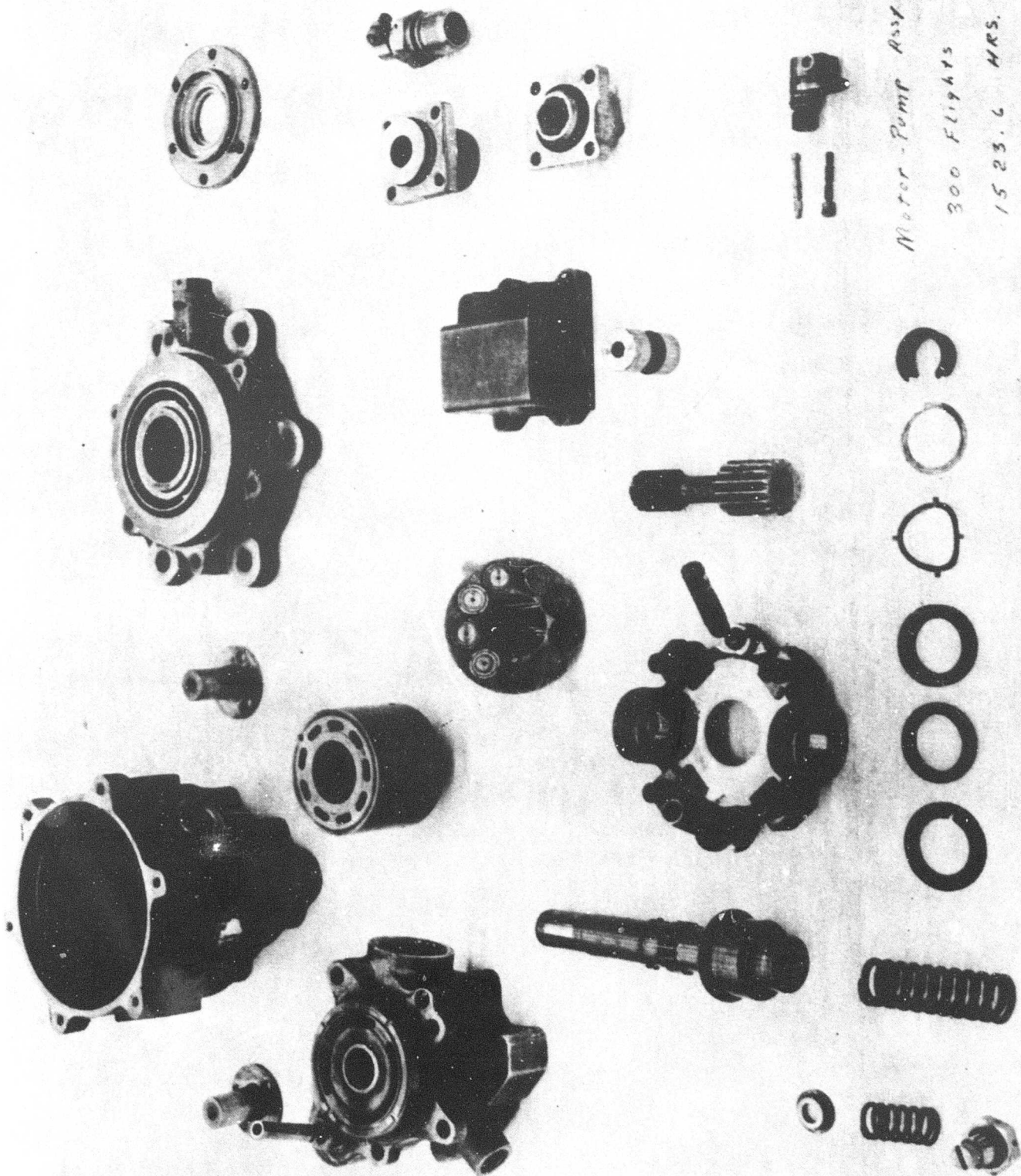

Figure 69. Disassembled Motor-Pump

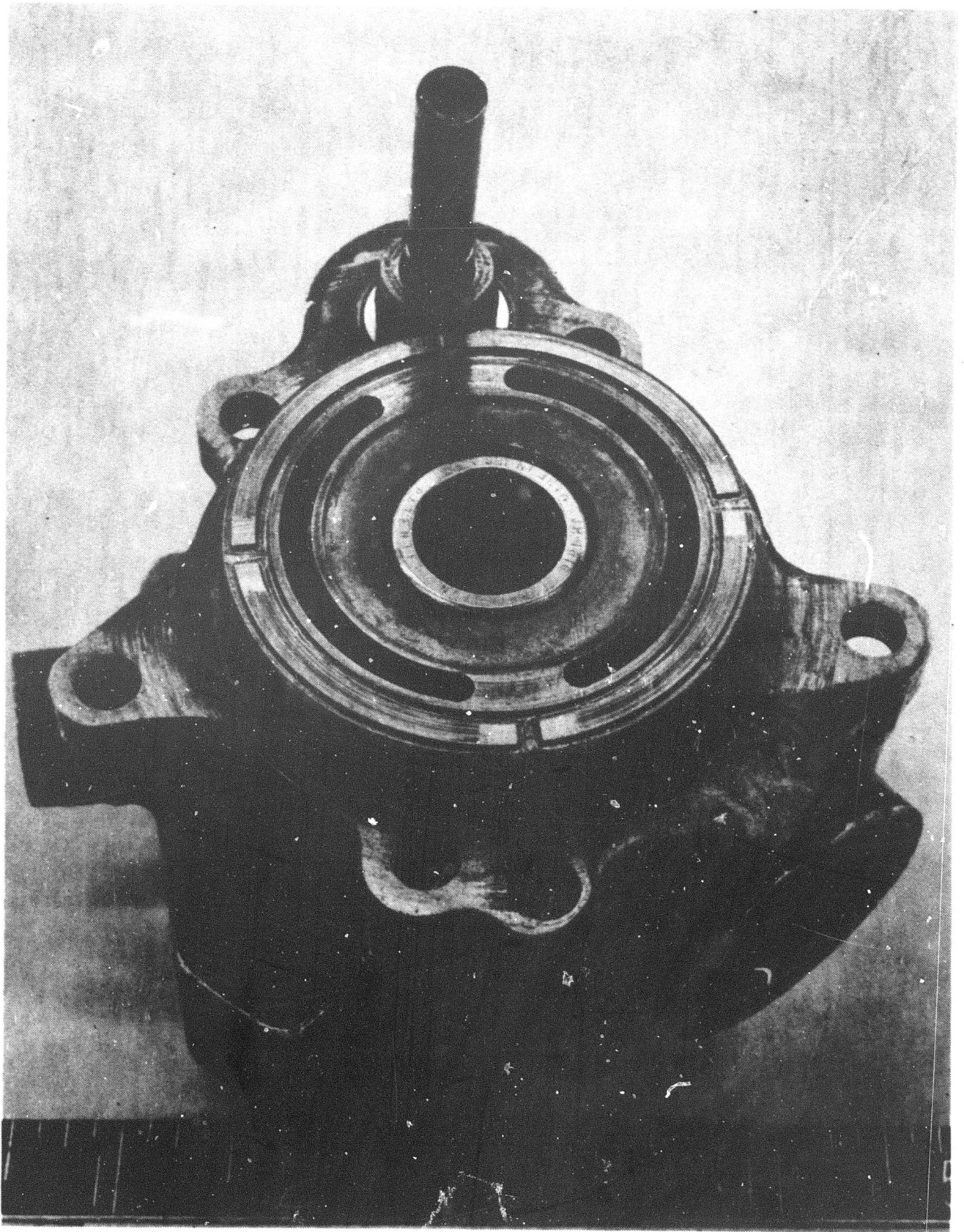

Figure 70. Motor-Pump Kidney Port Wear

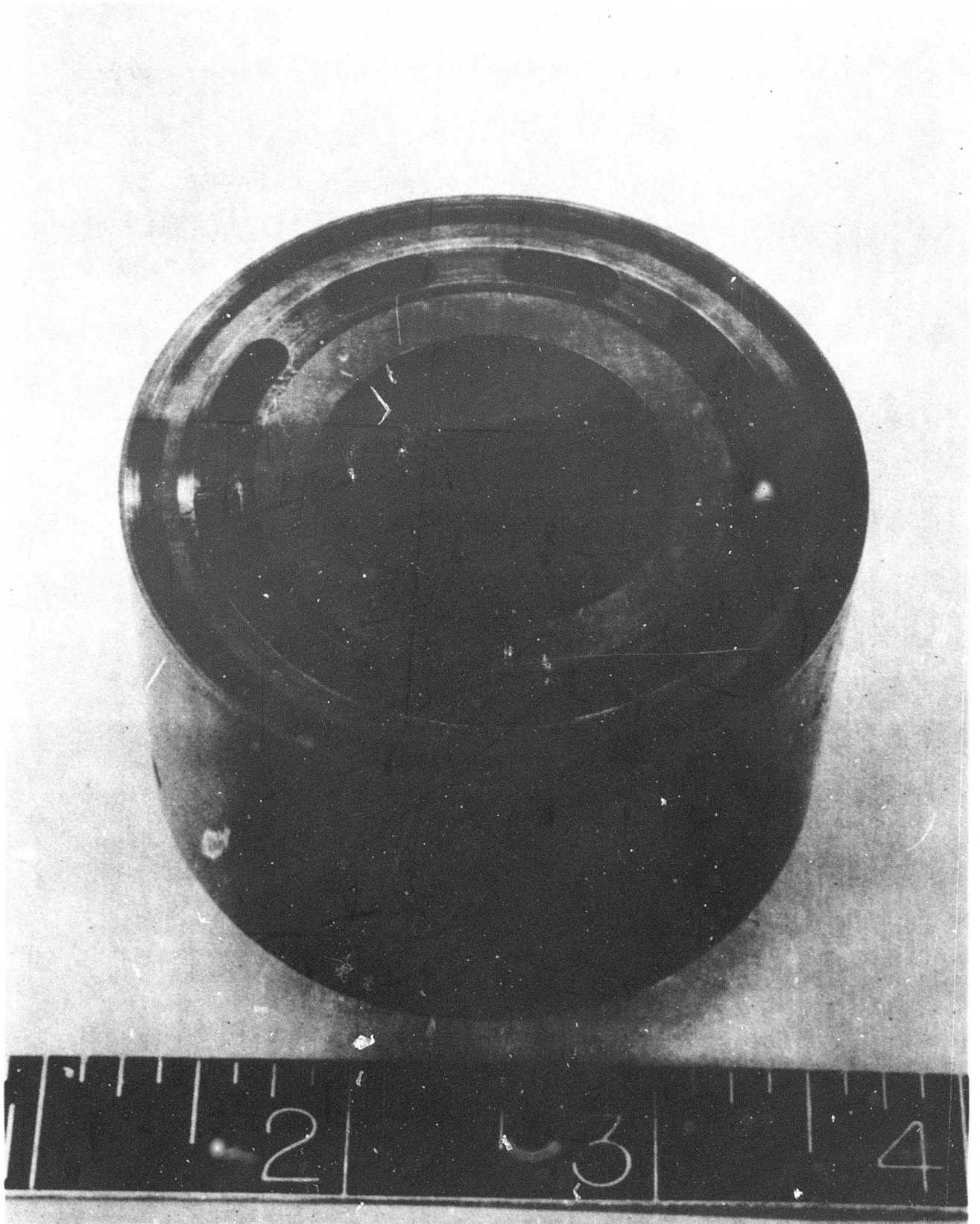

Figure 71. Motor-Pump Piston Barrel Valving Surface Wear

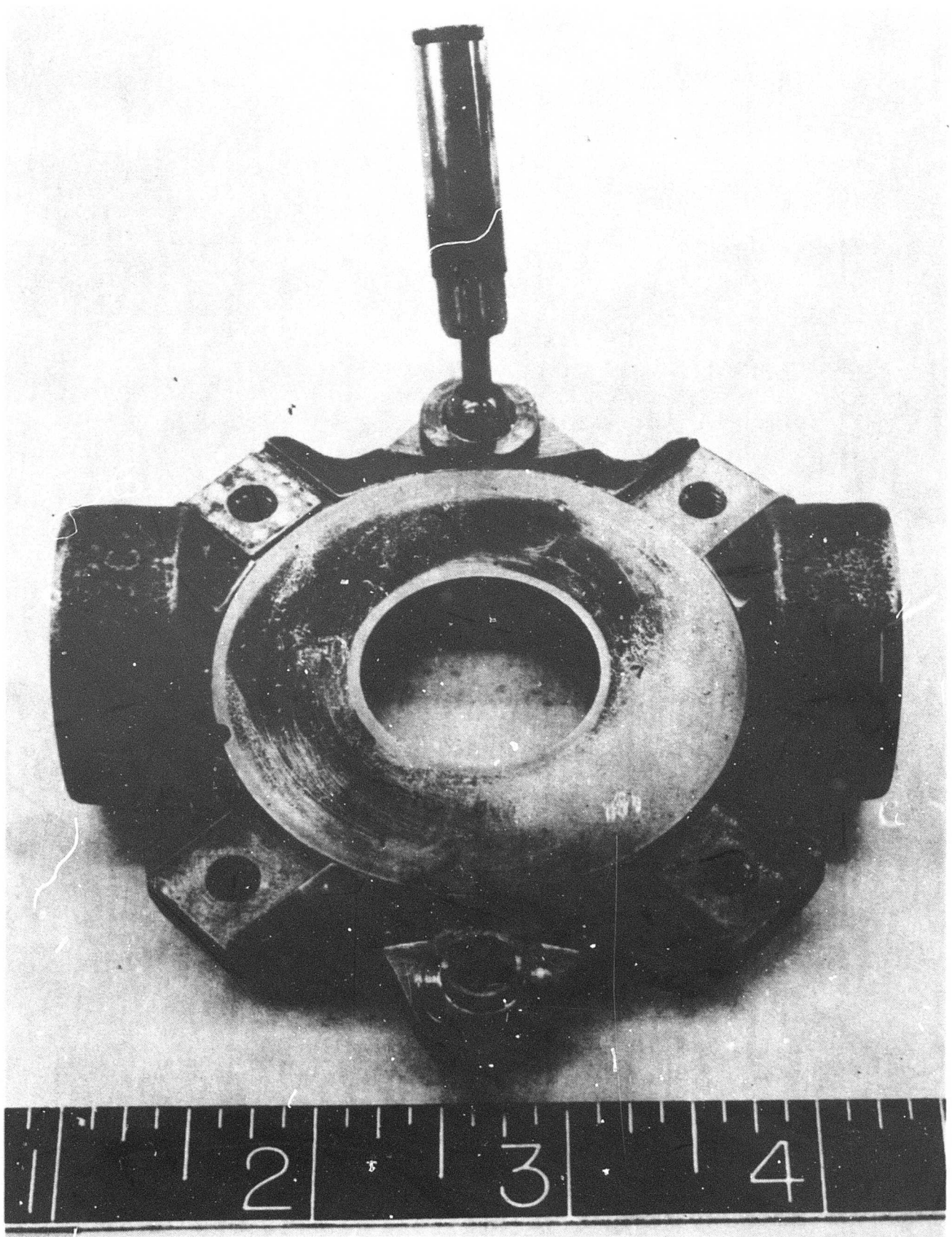

Figure 72. Motor-Pump Wobble Plate

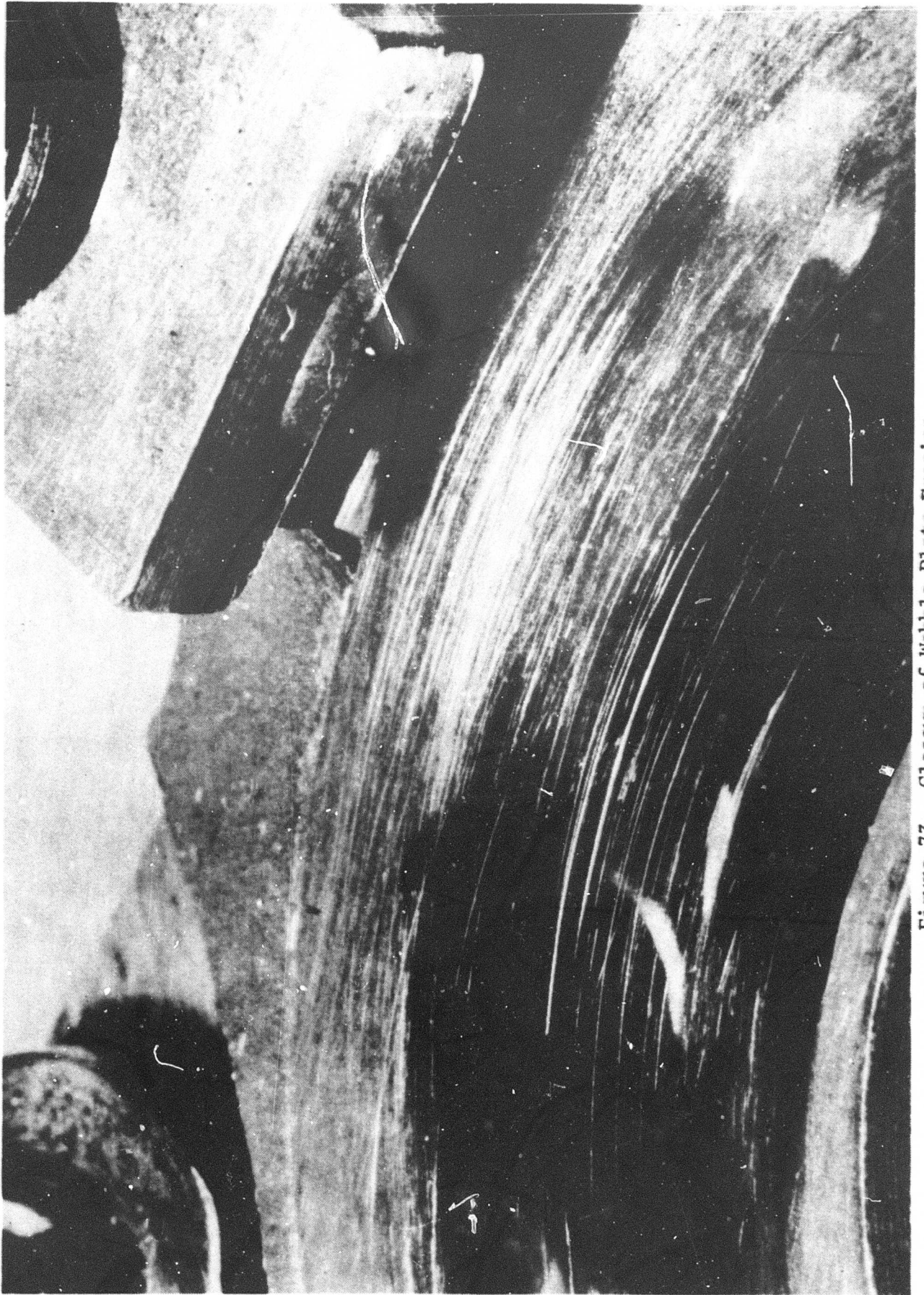

Figure 73. Closeup of Wobble Plate Erosion

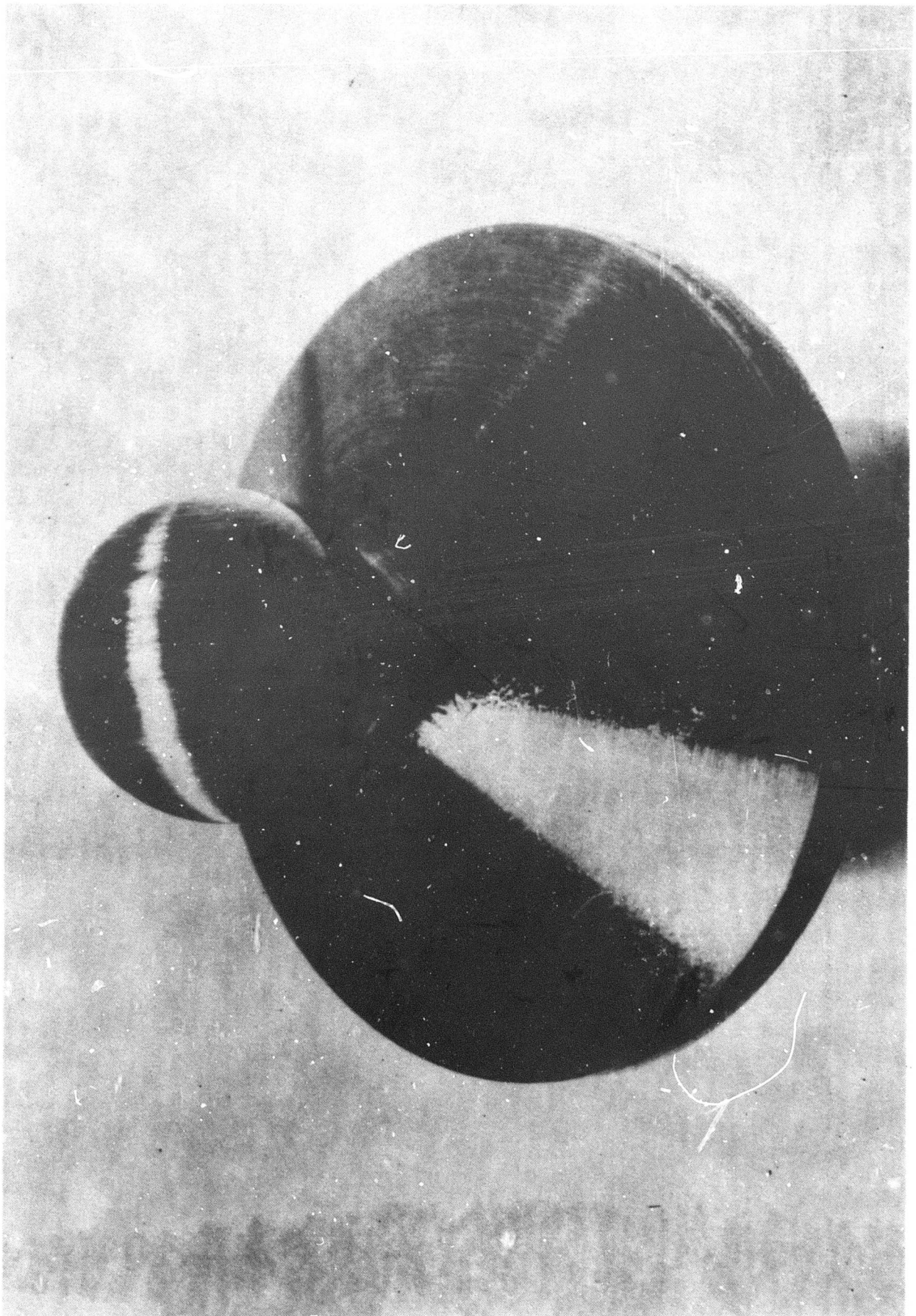

Figure 74. Motor-Pump Control Actuator Ball Joint

5. Erosion was noted at the outer diameter of the piston slipper shoes. This is shown in figure 75 and the enlarged view of figure 76.
6. The control valve shift spool was badly eroded on the large diameter of the spool. The severity of this is shown in figure 77.
7. The pump control actuator piston ball joints were found to have greater than normal freeplay.

The excessive erosion found on the shift spool and the outer diameter of the piston slipper shoes account for the contaminant found in the filters on initial runs of this motor-pump assembly. Increased case pressure at this time resulted in elimination of pump-generated contaminant. There was no pump-generated contaminant found after the increase of case pressure, indicating that the erosion process had been stopped.

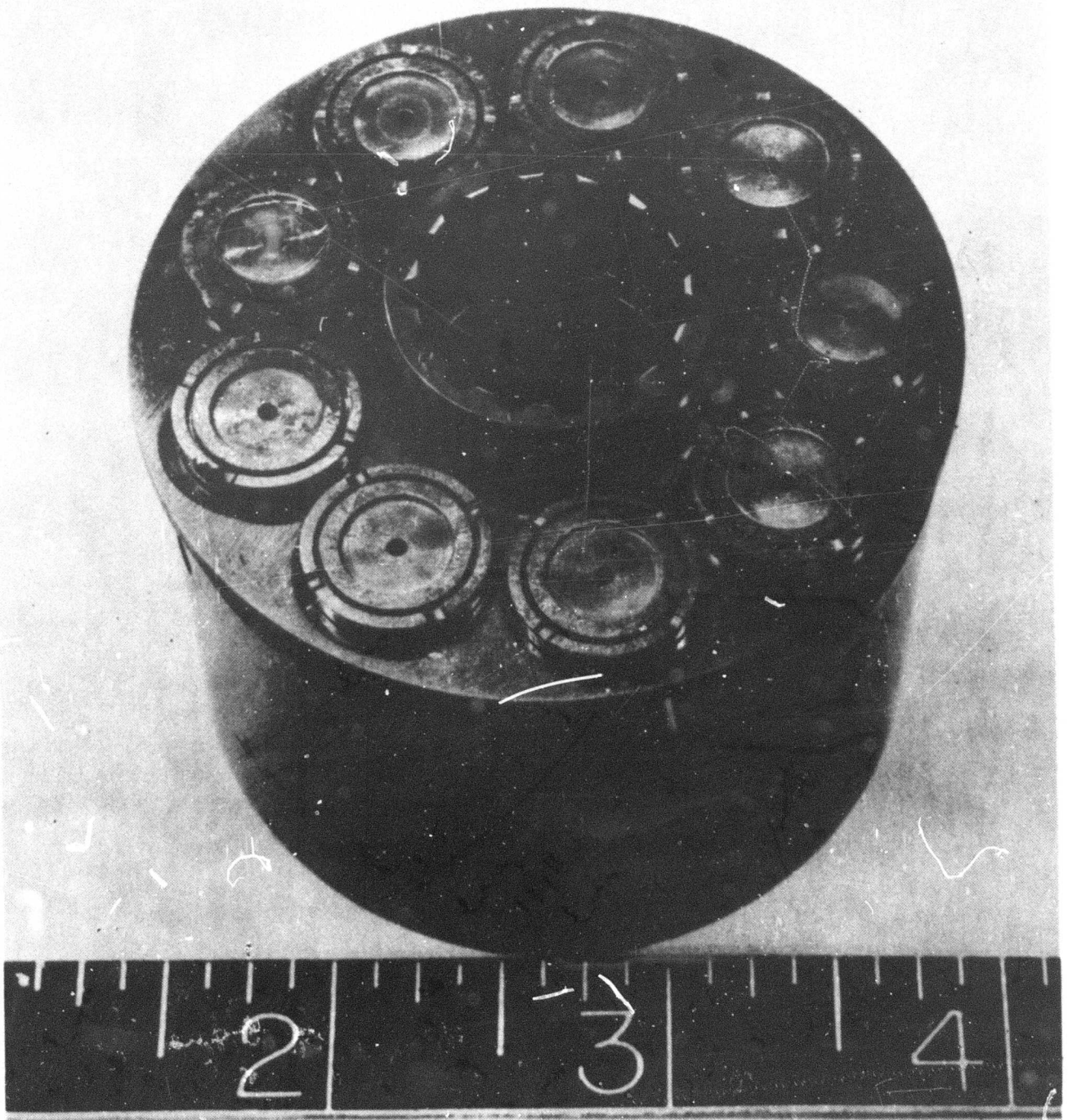

Figure 75. Motor-Pump Piston Slippers

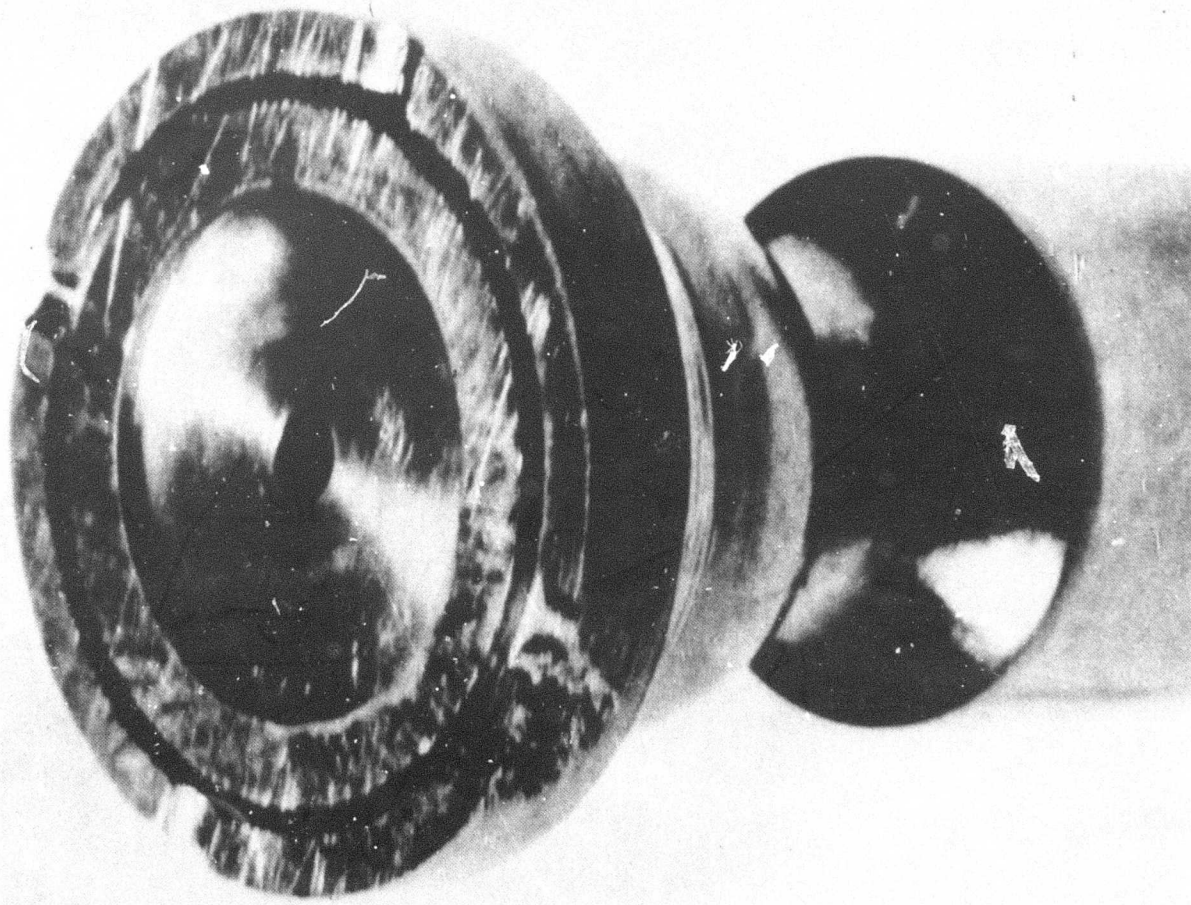

Figure 76. Enlarged View of Slipper Erosion

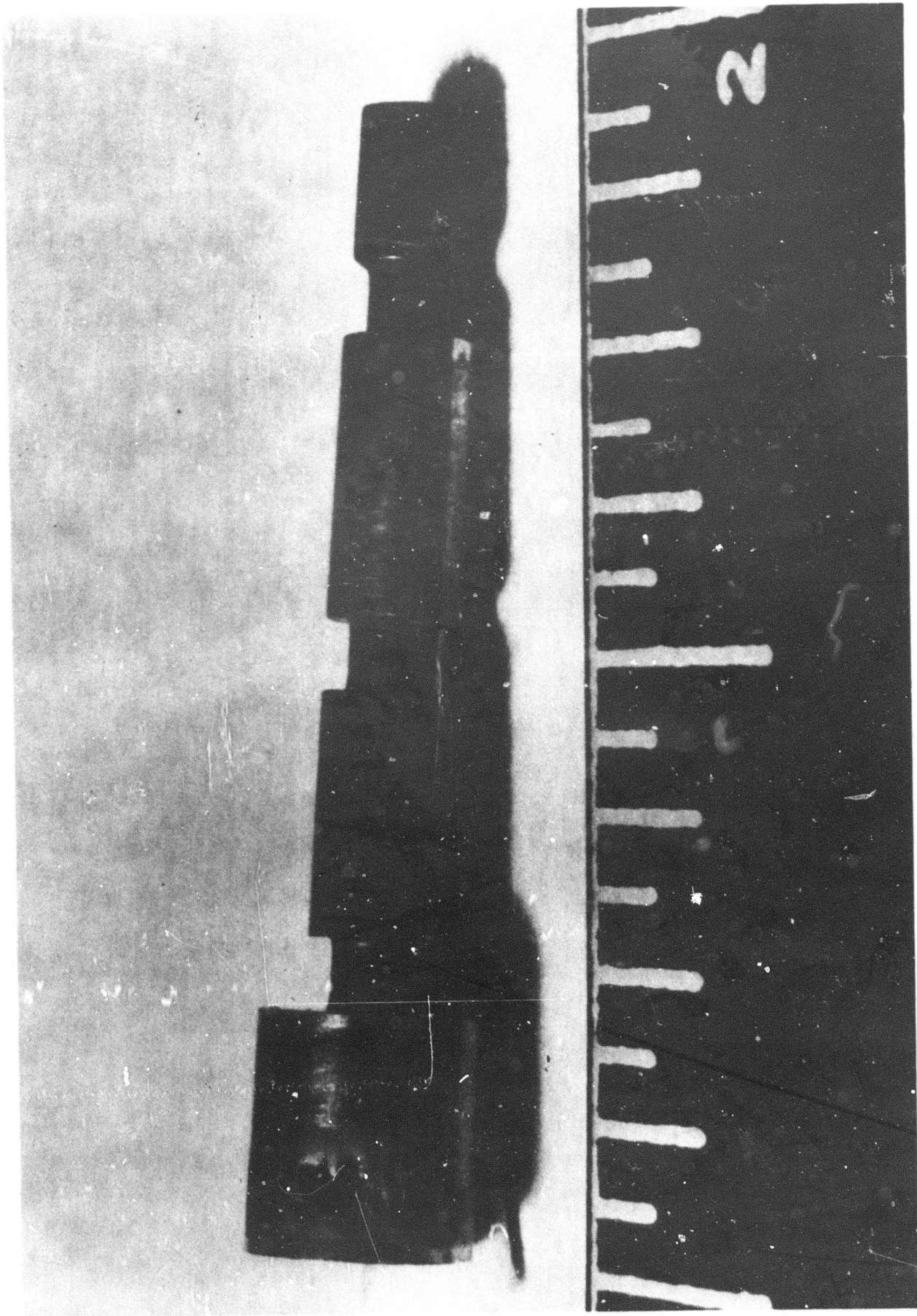

Figure 77 Motor-Pump Shift Spool Erosion

Section VI

PROGRAM SUMMARY AND CONCLUSIONS

Of the four basic demonstrations which constituted this program, two were very successful and the other two indicated that additional work should be done. The demonstrations conducted on the hydraulic version of the intermittent duty cycle simulator and the continuous duty cycle simulator were very successful. The former completed 10,000 landing gear cycles without an incident directly chargeable to the substation. The latter completed 1,500 hours on a typical flight control duty cycle and probably could have completed an additional 500 hours.

The tilt table test demonstration and the demonstration conducted on the mechanical version of the intermittent duty cycle simulator were less successful. The former was targeted at demonstrating the equivalent of 3,000 hours of life for the flywheel bearings when subject to the precessional loads incident to operation in three types of aircraft. The test demonstrated that the commercial "J"-type bearings used for this test were good for the equivalent of 750 to 1,000 hours of operation when used in aircraft similar to the XB-70. The test also demonstrated that when selectively located (i.e., flywheel axis of rotation parallel to fuselage centerline so that roll maneuvers do not generate precession loads) the bearings were good for 750 to 1,000 hours in more maneuverable aircraft. The latter test completed only 17 percent of the 10,000-cycle goal because the components available for the test were misconfigured for the application.

As a result of these tests numerous conclusions have been drawn. A number of these conclusions, dealing with a specific demonstration, have already been discussed at the end of the section covering that particular demonstration. Some of the more important of these will be repeated here. However, in general, the conclusions discussed in this section will cover those drawn from the continuous duty cycle tests and those drawn from the overall program. These conclusions are as follows:

1. Energy storage substations can be designed and fabricated to supply performance and weight saving improvements in excess of those which were established by analysis in the Phase I program (Report No. AFAPL-TR-66-29).
2. The high speed energy storage flywheel is compatible with the normal space, weight, reliability, service life, and maintainability requirements, as well as most of the environmental conditions which will be encountered in present-day and near-future aircraft.
3. The energy storage substation, which is inherently a source of mechanical shaft power, can be successfully coupled to a mechanical actuator. This approach is potentially the best method for utilizing the substation's full capability for both "intermittent" and "continuous"-type applications. However, before this full

capability can be realized, additional work must be done on mechanical couplings and particularly on the mechanical servo needed for continuous duty-cycle-type applications.

4. Charging and discharging a flywheel energy storage device has been demonstrated to be practical using hydraulic means.
5. The speed range of the flywheel and a present-day motor-pump can be coupled through a single mesh of spur gearing. The necessary technology to build such gearing with long life capability at high speed is presently available without further need for development.
6. The energy storage substation concept will enhance survivability. This conclusion is derived from several basic characteristics of the system as follows:
 - a. The energy storage substation reduces the size of the power generation and distribution system, thus reducing its target area with respect to enemy groundfire.
 - b. The energy storage substation is adaptable to use in armored power packs close to the point of power usage.
 - c. The energy storage substation is amenable to a variety of power inputs (hydraulic, pneumatic, electrical, or mechanical).
 - d. If the power from the primary power source is interrupted for any reason (such as gunfire damage), the stored energy in the substation will give the air vehicle greatly enhanced "get home" capability.
 - e. The flywheel containing energy storage substation is very amenable to mechanical power extraction. In its turn, mechanical power extraction when developed will make possible the construction of a compact, relatively projectile-resistant package.

The conclusions which can be drawn with respect to the various components making up the energy storage substation are as follows:

1. Motor Pump (New York Airbrake - Part No. 64 WK020152) - After it was found that this unit must operate at 150 to 200 psi case pressure, the performance of the motor-pump was consistently successful. Both the continuous duty test and the intermittent duty tests show that the principle of storing and extracting energy by means of a motor-pump is a very practical approach.

2. Gearbox (Vi-Star Gear Company - Model 6701) - This gearbox was operated at 8,000 rpm input and 52,400 rpm output and proved to be extremely rugged and reliable. Even though the gearbox was occasionally inadvertently abused, there was no failure chargeable to the gearbox. One of the gearboxes in the program has logged in excess of 1,576 hours and the other two range between 100 and 200 hours.
3. Flywheel (North American Rockwell Corporation - Part No. ER 2655-107) - Except for the precessional load problem previously discussed, the flywheel has proved to be an extremely reliable device. Several interesting failure mode characteristics were uncovered as follows:
 - a. In the event of bearing failure, the flywheel, acting as a gyroscope, continues to rotate around its own axis using the remaining bearing as support. The only sign of failure is rapid bearing temperature rise. There is very little audible sound level change and the flywheel will coast to a stop smoothly on shut-down.
 - b. The flywheel tip is traveling at 132,000 feet per minute (mach 2.3) in an evacuated housing (2 cm Hg abs). It was originally feared that if a leak occurred and a lubricating oil-air mixture entered the housing there was danger of a fire or explosion. Several leaks of this type have occurred and, so far, the only effect has been flywheel slowdown and increases in flywheel housing temperatures approaching 350° F. In one instance, mercury was drawn into the housing from a manometer. The result was a rapid flywheel slowdown and degradation in flywheel tip strength from 260,000 psi tensile to 210,000 psi. Based upon this tensile strength decrease, it is believed that the tip temperatures exceeded 600° F. However, nothing untoward occurred and this flywheel is the one which continued to complete the continuous duty cycle endurance test.
 - c. Vibration at critical speeds were considered a major problem which might lead to early flywheel failure. However, the flywheels used for this program were balanced to less than 0.005 inch-ounce and no critical speeds were encountered for any of the three flywheels involved.
4. Evacuation Scavenge and Lubricating Systems - These functions were accomplished by a compact stack of W. H. Nichols "Gerotor" pumps driven by a common drive shaft. All three systems worked without incident throughout the test in spite of the fact that, in at least two instances, large quantities of metal chips resulting from a flywheel bearing failure passed through the scavenge pump. The most interesting conclusion reached is the fact that a small gear pump will consistently maintain a vacuum of 2 to 3 cm Hg abs when its outlet is wetted with oil.

UNCLASSIFIED
Security Classification

| DOCUMENT CONTROL DATA - R2D | | |
|---|---|---------------------|
| <i>(Security classification of title, body of abstract and indexing annotation must be entered when the overall report is classified)</i> | | |
| 1 ORIGINATING ACTIVITY (Corporate author) North American Aviation/Los Angeles Division International Airport Los Angeles, Calif 90009 | 2a REPORT SECURITY CLASSIFICATION UNCLASSIFIED | 2b GROUP NA |
| 3 REPORT TITLE Experimental Demonstration of Energy Storage Substations for Aircraft Actuation Functions | | |
| 4 DESCRIPTIVE NOTES (Type of report and inclusive dates) Final Report July 66 - Dec 67 | | |
| 5 AUTHOR(S) (Last name, first name, initial) Helsley, C. W. Jr. Call, B. J. | | |
| 6 REPORT DATE Dec 67 | 7a TOTAL NO. OF PAGES 116 | 7b NO. OF REFS 0 |
| 8a CONTRACT OR GRANT NO AF 33(615)-5173 | 9a. ORIGINATOR'S REPORT NUMBER(S) NA - 67 - 964 | |
| b PROJECT NO 3145 | 9b. OTHER REPORT NO(S) (Any other numbers that may be assigned this report) AFAPL-TR-67-143 | |
| c Task No. 214508 | | |
| d | | |
| 10 AVAILABILITY LIMITATION NOTICES Qualified requesters may obtain copies of this report from DDC. Foreign announcement and dissemination of this report by DDC is unauthorized. | | |
| 11 SUPPLEMENTARY NOTES | 12 SPONSORING MILITARY ACTIVITY Air Force Aero Propulsion Laboratory Directorate of Laboratories AFSC Wright Patterson AFB, Ohio 45433 | |
| 13 ABSTRACT Essentially there are two principal uses for flywheels. One is to create precessional forces (such as gyroscopes), the other is to store up kinetic energy. This program demonstrated the use of optimized energy storage flywheels for the purpose of supplying peak energy demands in aircraft flight control and utility actuation function duty cycles. Three simulators were used. One was a tilt table for investigation of precessional loads on bearings. Another was the XB-70 landing gear simulator for demonstration of both hydraulic and mechanical power extraction from flywheels in the performance of intermittent type of aircraft actuation duty cycles. A third simulator demonstrated 1,500 hours of aircraft flight control operation, wherein a bank of three XB-70 elevons were supplied one third of their peak hydraulic flow from a motor-pump driven by a flywheel. This test demonstrated 300 flights of 5 hours each. The program demonstrated the operating characteristics and the feasibility of using flywheel energy storage substations in the accomplishment of aircraft actuation functions. The program also verified the validity of the weight saving estimates made in Phase I. | | |

DD FORM 1473
1 JAN 64

UNCLASSIFIED
Security Classification

| 14. KEY WORDS | LINK A | | LINK B | | LINK C | |
|--|--------|----|--------|----|--------|----|
| | ROLE | WT | ROLE | WT | ROLE | WT |
| Flywheels Energy Storage Gears Bearings Shaft Seals Pumps Motors | | | | | | |

INSTRUCTIONS

1. **ORIGINATING ACTIVITY:** Enter the name and address of the contractor, subcontractor, grantee, Department of Defense activity or other organization (*corporate author*) issuing the report.

2a. **REPORT SECURITY CLASSIFICATION:** Enter the overall security classification of the report. Indicate whether "Restricted Data" is included. Marking is to be in accordance with appropriate security regulations.

2b. **GROUP:** Automatic downgrading is specified in DoD Directive 5200.10 and Armed Forces Industrial Manual. Enter the group number. Also, when applicable, show that optional markings have been used for Group 3 and Group 4 as authorized.

3. **REPORT TITLE:** Enter the complete report title in all capital letters. Titles in all cases should be unclassified. If a meaningful title cannot be selected without classification, show title classification in all capitals in parenthesis immediately following the title.

4. **DESCRIPTIVE NOTES:** If appropriate, enter the type of report, e.g., interim, progress, summary, annual, or final. Give the inclusive dates when a specific reporting period is covered.

5. **AUTHOR(S):** Enter the name(s) of author(s) as shown on or in the report. Enter: last name, first name, middle initial. If military, show rank and branch of service. The name of the principal author is an absolute minimum requirement.

6. **REPORT DATE:** Enter the date of the report as day, month, year; or month, year. If more than one date appears on the report, use date of publication.

7a. **TOTAL NUMBER OF PAGES:** The total page count should follow normal pagination procedures, i.e., enter the number of pages containing information.

7b. **NUMBER OF REFERENCES:** Enter the total number of references cited in the report.

8a. **CONTRACT OR GRANT NUMBER:** If appropriate, enter the applicable number of the contract or grant under which the report was written.

8b, 8c, & 8d. **PROJECT NUMBER:** Enter the appropriate military department identification, such as project number, subproject number, system numbers, task number, etc.

9a. **ORIGINATOR'S REPORT NUMBER(S):** Enter the official report number by which the document will be identified and controlled by the originating activity. This number must be unique to this report.

9b. **OTHER REPORT NUMBER(S):** If the report has been assigned any other report numbers (*either by the originator or by the sponsor*), also enter this number(s).

10. **AVAILABILITY/LIMITATION NOTICES:** Enter any limitations on further dissemination of the report, other than those

imposed by security classification, using standard statements such as:

- (1) "Qualified requesters may obtain copies of this report from DDC."
- (2) "Foreign announcement and dissemination of this report by DDC is not authorized."
- (3) "U. S. Government agencies may obtain copies of this report directly from DDC. Other qualified DDC users shall request through _____."
- (4) "U. S. military agencies may obtain copies of this report directly from DDC. Other qualified users shall request through _____."
- (5) "All distribution of this report is controlled. Qualified DDC users shall request through _____."

If the report has been furnished to the Office of Technical Services, Department of Commerce, for sale to the public, indicate this fact and enter the price, if known.

11. **SUPPLEMENTARY NOTES:** Use for additional explanatory notes.

12. **SPONSORING MILITARY ACTIVITY:** Enter the name of the departmental project office or laboratory sponsoring (*paying for*) the research and development. Include address.

13. **ABSTRACT:** Enter an abstract giving a brief and factual summary of the document indicative of the report, even though it may also appear elsewhere in the body of the technical report. If additional space is required, a continuation sheet shall be attached.

It is highly desirable that the abstract of classified reports be unclassified. Each paragraph of the abstract shall end with an indication of the military security classification of the information in the paragraph, represented as (TS), (S), (C), or (U).

There is no limitation on the length of the abstract. However, the suggested length is from 150 to 225 words.

14. **KEY WORDS:** Key words are technically meaningful terms or short phrases that characterize a report and may be used as index entries for cataloging the report. Key words must be selected so that no security classification is required. Identifiers, such as equipment model designation, trade name, military project code name, geographic location, may be used as key words but will be followed by an indication of technical context. The assignment of links, rules, and weights is optional.