

UNCLASSIFIED

AD NUMBER

AD826172

LIMITATION CHANGES

TO:

Approved for public release; distribution is unlimited.

FROM:

Distribution authorized to U.S. Gov't. agencies and their contractors;  
Administrative/Operational Use; 10 JAN 1968.  
Other requests shall be referred to Office of the Adjutant General (Army), Washington, DC 20310.

AUTHORITY

OACSFOR ltr 13 Sep 1973

THIS PAGE IS UNCLASSIFIED



AD826172

FIELD EVALUATION OF THE  
MEDICAL COMPANY  
(AIR AMBULANCE) TOE 8-137E

DDC  
FEB 7 1968

ARMY CONCEPT TEAM IN VIETNAM  
APO SAN FRANCISCO 96384

STATEMENT #0 UNCLASSIFIED

This document is subject to special export controls and each transmittal to foreign governments or foreign nationals may be made only with special approval of the

DEPARTMENT OF THE ARMY  
ARMY CONCEPT TEAM IN VIETNAM  
APO San Francisco 96384

FIELD EVALUATION OF THE  
MEDICAL COMPANY  
(AIR AMBULANCE) TOE 8-137E

D D  
RECEIVED  
FEB 7 1968  
RECEIVED

DEPARTMENT OF THE ARMY  
ARMY CONCEPT TEAM IN VIETNAM  
APO San Francisco 96384

AVIB-AAD

10 January 1968

SUBJECT: Final Report - Field Evaluation of Medical Company  
(Air Ambulance) (ACA-19F) (U)

TO: Commanding General  
United States Army Vietnam  
ATTN: AVHGC-DST  
APO 96375

1. Reference: Letter, AVHGC-DH, Headquarters, US Army Vietnam, dated 23 February 1967, subject: Letter of Instruction.

2. In accordance with the provisions of reference 1 above, the attached final report is forwarded for review and transmittal to Department of the Army.

3. Request that a copy of the USARV and CINCUSARPAC forwarding indorsements be furnished Commanding Officer, ACTIV.

FOR THE COMMANDER:

1 Incl  
as

  
F. A. KLEIN  
CPT AGC  
Adjutant

AVHGC-DST (10 Jan 68) 1st Ind  
SUBJECT: Final Report - Field Evaluation of the Medical Company (Air  
Ambulance) TOE 8-137E (ACA-19F)

HEADQUARTERS, UNITED STATES ARMY VIETNAM, APO San Francisco 96375

14 JAN 1968

TO: Commander in Chief, United States Army, Pacific, ATTN: GPOP-DT,  
APO 96558

1. The ACTIV final report, subject as above, has been reviewed by this headquarters. Pertinent comments are as follows:

a. Nonconcur that the Medical Company, (Air Ambulance), should be reorganized as recommended by this report, as a solution to the problem of achieving maximum efficiency and effectiveness from medical air evacuation resources. The Air Ambulance Company is not considered to be an appropriate organization for accomplishment of the air medical evacuation mission in Vietnam. The organizational structure is not designed to support the operational requirements imposed upon such a unit in this environment. The nature of tactical operations is such that the Medical Detachment (Helicopter Ambulance) (RA) is better suited due to its inherent ability for independent employment and adaptability to shifting operational requirements.

b. The field siting of the Air Ambulance Company's platoons at distant locations, with the capability of remaining there for a relatively short period of time because of their dependability on the company base, does not permit optimum utilization. The Medical Detachment (Helicopter Ambulance) (RA) is adequately organized for self-sufficiency to preclude such dependency.

c. Retention of the Air Ambulance Company in Vietnam is not recommended. However, if retained, they should be reorganized as recommended by the study with the following exceptions:

(1) The helicopter platoons should be organized so that they are capable of independent operations for a prolonged period of time (page 46, paragraph Blc(1), section III).

(2) With adequate numbers of direct exchange hoists in-country, one hoist per two helicopters (as presently authorized) is considered adequate (page 47, paragraph Blc(5), section III).

14 JAN 68

AVHGC-DST (10 Jan 68)

SUBJECT: Final Report - Field Evaluation of the Medical Company (Air Ambulance) TOE 8-137E (ACA-19F)

(3) Centralization of the company should be predicated upon operational requirements and not on an arbitrary decision to base the unit at one location (page 47, paragraph B2, section III).

2. Subject report is forwarded for comment or approval.

FOR THE COMMANDER:

*John V. Getchell*

1 Incl  
Final Report

JOHN V. GETCHELL  
Captain, AGC  
Assistant Adjutant General

DEPARTMENT OF THE ARMY  
ARMY CONCEPT TEAM IN VIETNAM  
APO San Francisco 96384

FINAL REPORT

FIELD EVALUATION OF THE  
MEDICAL COMPANY  
(AIR AMBULANCE) TOE 8-137E

ACTIV PROJECT NO. ACA-19F

25 November 1967

Approved:

*William G. Sullivan*  
WILLIAM G. SULLIVAN  
Colonel, Infantry  
Commanding

## AUTHORITY

Letter, Headquarters, United States Army Vietnam, AVHGC-DH, 23 February 1967, subject: Letter of Instructions. CINCPAC Message, DTG 180240Z Nov 66.

## ACKNOWLEDGMENTS

The Army Concert Team in Vietnam is indebted to the following officers for their help in the evaluation: Commanding Officers of the 44th Medical Brigade, Colonel Ray E. Miller and Colonel Frederick W. Timmerman, and Commanding Officers of the 498th Medical Company (Air Ambulance), LTC William R. Knowles and LTC Charles V. Heath.

## PROJECT OFFICER

LTC Eugene R. Lucas, Artillery

LTC James D. Hawthorne, Artillery

## EVALUATORS

LTC Lloyd E. Spencer, Medical Service Corps

MAJ John W. Lowe, Medical Service Corps

CPT Walter M. Harris, Medical Service Corps

# CONTENTS

|  | <u>Page</u> |
|--|-------------|
| SUMMARY  | v           |
| I. INTRODUCTION  |             |
| A. Purpose . . . . .   | 1           |
| B. Background . . . . .  | 1           |
| C. Objectives . . . . .  | 2           |
| D. Evaluation Design . . . . .                                 | 2           |
| II. DISCUSSION   |             |
| A. Objective 1 - Performance . . . . .                         | 5           |
| B. Objective 2 - Increased Operational Effectiveness . . . . . | 23          |
| III. CONCLUSIONS AND RECOMMENDATIONS                           |             |
| A. Conclusions . . . . .                                       | 45          |
| B. Recommendations . . . . .                                   | 46          |
| ANNEXES  |             |
| A. Decision/Action Sequence Diagrams . . . . .                 | A1-A7       |
| B. Helicopter Internal Personnel Hoist Operations . . . . .    | B1-B5       |
| C. Evacuation Missions . . . . .                               | C1-C3       |
| D. Additional Duties - Helicopter Platoons . . . . .           | D1-D3       |
| E. Ground Control Approach Radar (GCA) . . . . .               | E-1         |
| F. Personnel Modifications to TOE 1-837G . . . . .             | F1-F4       |
| G. Glossary . . . . .  | G1-G2       |
| H. References . . . . .  | H-1         |
| I. Distribution . . . . .                                      | I1-I2       |

# FIGURES

| <u>Figures</u>  | <u>Page</u> |
|---|-------------|
| 1. Command and Control . . . . .  | 6           |
| 2. Medical Facilities and Evacuation Helicopter<br>Field Sites, II CTZ . . . . .                        | 11          |
| 3. Litter Configuration . . . . .   | 17          |
| 4. Internally Mounted Personnel Hoist Extended . . . . .  | 18          |
| 5. Hoist Viewed from Inside the Helicopter . . . . .  | 19          |
| 6. Medical Treatment and Survival Equipment<br>Aboard Evacuation Helicopter. . . . .                    | 20          |
| 7. Daily Man-hours per Area Spent on Additional<br>Duty in the Helicopter Platoons . . . . .            | 24          |
| 8. Current Functional Organizational Structure<br>of the 498th Medical Company (Air Ambulance). . . . . | 27          |
| 9. Organization Structure of the Medical<br>Helicopter Detachment, TOE 8-500D, Team RA . . . . .        | 28          |
| 10. Proposed Organizational Structure of the<br>Medical Company (Air Ambulance) . . . . .               | 31          |
| 11. Organization of Medical Company (Air Ambulance)<br>TOE 8-137G. . . . .                              | 32          |
| A-1. Decision Action Sequence Diagram -<br>Helicopter Platoon . . . . .                                 | A-3         |
| A-2. Decision Action Sequence Diagram -<br>Individual Helicopter . . . . .                              | A-5         |
| B-1. Extreme Maximum and Mean Maximum<br>Temperatures - II CTZ . . . . .                                | B-2         |
| B-2. UH-1D Helicopter Operating Weight . . . . .  | B-3         |
| B-3. Maximum Gross Weight for Hovering<br>Out-of-Ground Effect with Normal<br>Rated Power . . . . .     | B-3         |

## SUMMARY

The purpose of this project was to evaluate operations of the Medical Company (Air Ambulance), TOE 8-137E, in support of counterinsurgency operations in the Republic of Vietnam to determine whether a significant increase in the unit's effectiveness could be achieved by changes in personnel and equipment authorization, methods of employment, or organization.

The field evaluation of all elements of the 498th Medical Company (Air Ambulance) was made by sending three Medical Services Corps officers and two combat arms project officers to the unit to collect data through questionnaires, personal interviews, record searches, and by observing and participating in combat operations.

Employment of elements of the 498th Medical Company (Air Ambulance) in three widely separated locations in the Republic of Vietnam (RVN) restricted the unit from attaining the maximum capability and flexibility inherent in its present organization. The deployment of three helicopter platoons on a permanent basis to locations away from company headquarters and other company support required these platoons to duplicate the company effort in administration, operations, aircraft maintenance, supply, and motor maintenance. The organization of the helicopter platoons closely resembled the organization of the Medical Helicopter Ambulance Detachment, TOE 8-500D, Team RA. As a result, all elements of the company required adjustments in organization in order to accomplish the unit mission. The size, terrain, and climatic conditions of the area of responsibility and the lift capability and pay load of the UH-1D helicopter limited the capability of the Air Ambulance Company to perform all aspects of its mission.

The resources of the company were not sufficient to provide support for any area the size of the RVN II Corps Tactical Zone (CTZ), where they were located. Since there was no requirement for the unit to operate a company heliport or establish an instrument landing facility, the Ground Controlled Approach Radar Set, AN/TPN-8 and the Radio Beacon Set, AN/GRN-6 were transferred to the 125th Air Traffic Control Company.

When the tactical situation and mission requirements permit centralized operation, the effectiveness of the company could be improved by basing the entire unit at one location and employing platoons or sections at distant points as required for limited periods of time. Mission accomplishment in counterinsurgency operations, however, often requires decentralized operation. The company should be capable of deploying at least two helicopter platoons with supporting elements to distant and separate locations for indefinite periods of time. It is recommended that the 498th Medical Company (Air Ambulance) be converted to TOE 8-137G, as modified by this report, as soon as possible.

**THIS PAGE NOT USED**

# I. (U) INTRODUCTION

## A. PURPOSE

The purpose of this project was to evaluate operations of the Medical Company (Air Ambulance), TOE 8-137E, in support of counterinsurgency operations in the Republic of Vietnam (RVN) to determine whether a significant increase in the unit's effectiveness could be achieved by changes in personnel and equipment authorization, method of employment, or organization.

## B. BACKGROUND

1. The 498th Medical Company (Air Ambulance) was the first TOE air ambulance unit to be employed in combat. The mission of the company is to provide aeromedical evacuation of patients and emergency movement of medical personnel and accompanying equipment and supplies as required. The company is assigned to a Field Army medical brigade, an independent corps, or task force as required. It is allocated on the basis of one per Field Army and one per independent corps or task force as required. The company normally is employed under the overall direction of the medical brigade commander and usually operates under mission-type orders. Current doctrine contained in Field Manual 8-16, Medical Service, Field Army, states that each helicopter platoon has the capability, when augmented by a section of the maintenance platoon and an element of the airfield service section, to operate in a separate location. When separated, the platoon is dependent upon the company headquarters for administrative support, except for local attachment to nearby units for logistical support such as mess.

2. When the 498th Medical Company (Air Ambulance), TOE 8-137E, was deployed to RVN the tactical situation required that the company be deployed at three locations: Pleiku, Qui Nhon, and Nha Trang. These sites were separated by distances up to 120 nautical miles. The platoons were fragmented in some instances up to 100 nautical miles. The primary means of patient evacuation in RVN was air because this was the only secure means of transportation. The company provided aeromedical evacuation of casualties from the battle area to the supported unit's medical facility, to hospital facilities, and from one hospital to another.

3. The method of employment of the company in Vietnam revealed problem areas which appeared to be inherent in doctrine and the organizational structure because there was no qualification on the length of time helicopter platoons would remain at separate locations. The magnitude of these problem areas, as well as changes required to increase the unit's effectiveness in

supporting counterinsurgency operations, could only be achieved by a detailed evaluation of the unit's actual operation. Evaluation of the unit under a peacetime or simulated environment would not have produced the combat data necessary to determine what changes were required to increase its effectiveness in RVN.

4. Other medical air ambulance units employed in combat in RVN during the period of the evaluation were the 82d Medical Detachment (Helicopter Ambulance) operating from Soc Trang in the Delta and the 57th, 254th, and 283d Medical Detachments (Helicopter Ambulance) all operating from Long Binh Post, 13 miles NE of Saigon. Because the operations of the company could not be related to the operations of the detachments, no attempt was made to compare the company with the detachments.

#### C. OBJECTIVES

##### 1. Objective 1 - Performance

Describe the performance of the Medical Company (Air Ambulance), TOE 8-137E, in support of counterinsurgency operations in RVN.

##### 2. Objective 2 - Increased Operational Effectiveness

Determine what changes in personnel and equipment authorizations, methods of employment, or organization, if any, will improve the operational effectiveness of the Medical Company (Air Ambulance), TOE 8-137E, in support of counterinsurgency operations.

#### D. EVALUATION DESIGN

##### 1. Setting of the Project

Evaluation of the 498th Medical Company (Air Ambulance) was conducted in II Corps Tactical Zone (CTZ) of the Republic of Vietnam (RVN), which provided widely varied topographical conditions. See DA pamphlet 550-40, Army Area Handbook on Vietnam, for detailed terrain and environment description.

##### 2. Methodology

###### 1. Data Collection

(1) The primary sources of data were personnel of the company. Analysis of the experience factor of the personnel completing the questionnaires revealed the following information:

| <u>Personnel</u>                      | <u>Number</u>     |
|---------------------------------------|-------------------|
| Medical Service Corps Officers        | 29                |
| Officers from other branches          | 4                 |
| Warrant Officers                      | 17                |
| <br>                                  |                   |
| <u>Five Years Service or More</u>     | <u>Percentage</u> |
| Officers and Warrant Officers         | 54                |
| Enlisted men                          | 21                |
| <br>                                  |                   |
| <u>Served in RVN 6 Months or More</u> |                   |
| Officers and Warrant Officers         | 50                |
| Enlisted men                          | 81                |

Recommendations of medical group and brigade commanders were collected and evaluated. Other sources of information included ACTIV and United States Army, Vietnam (USARV) files, after-action reports, and operational reports.

(2) The primary means of collecting data was through questionnaires. Field observation and document searches conducted by the data collection team contributed a large amount of valuable data. The data collection team consisted of three Medical Service Corps officers and one enlisted man. All of the officers were rated aviators, experienced in the operation of medical air ambulance units. Two of the officers had served with helicopter ambulance detachments in Vietnam. During the evaluation period the evaluators participated in numerous combat assault and medical evacuation missions.

#### b. Analysis

The data were analyzed qualitatively and quantitatively. Information required to accomplish objective 1 was obtained by reviewing the operational records of the unit and by collecting current data relating to operations. Information required to accomplish objective 2 was obtained by analyzing the effect that changes in personnel, equipment, organization, and methods of employment might produce on the unit's operations as related to the current method of employment.

### 3. Limitations and Variables

a. The unit's bases of operation were located at fixed military airfields. They were housed in semi-permanent structures and used facilities and equipment that were not organic to the company. These factors limited the evaluation of the utilization of all equipment and personnel authorized by TOE.

b. Twenty-four helicopter pilots were assigned to the unit in excess of TOE by General Order 37, Headquarters, United States Army, Pacific, dated 1 March 1966. This augmentation recognized the requirement for co-pilots when the company was committed to combat. Additional personnel were assigned above this special authorization to provide the unit with a 24-hour operational capability.

#### 4. Support Requirements

Limited administrative support required by the data collection team was provided by the 498th Medical Company (Air Ambulance).

#### 5. Schedule of Events

|                        |   |
|------------------------|---|
| 15 Jul 66              | Preliminary investigation completed.                          |
| 24 Oct 66              | Evaluation plan forwarded to CGUSACDC thru CINCUSARPAC.       |
| 13 Dec 66              | DA approved evaluation plan for conduct in RVN.               |
| 13 Dec 66 to 13 Feb 67 | Data collection plan prepared.                                |
| 31 Jan 67              | Three officers evaluators and one clerk typist arrived ACTIV. |
| 1 to 12 Feb 67         | Project Officer orientation.                                  |
| 13 Feb 67              | Data collection commenced.                                    |
| 13 Apr 67              | Data collection terminated.                                   |
| 2 Jul 67               | Completion of draft report.                                   |

## II. (U) DISCUSSION

### A. OBJECTIVE 1 - PERFORMANCE

#### 1. Employment

##### a. General

(1) The 498th Medical Company (Air Ambulance) was assigned to the 44th Medical Brigade located in Saigon and placed under operational control of the 43d Medical Group located in Nha Trang (figure 1). The mission of the company was to provide unit, division, and field army level aeromedical evacuation of patients of all US and Free World Military Assistance Forces (US/FWMAF) operating within II CTZ. Support was also provided to the Army of the Republic of Vietnam (ARVN) and Vietnamese nationals when ARVN resources were unable to meet this requirement.

(2) The initial deployment of the company was dictated by the availability of secure areas from which to base operations, real estate availability, the requirement to provide the greatest area coverage in the shortest response time, and proximity to medical treatment facilities. Doctrine as outlined in FM 8-16 states that the helicopter platoons may operate away from the company base with no time limitation on deployment. The company headquarters, flight operations platoon-maintenance platoon, and the first helicopter platoon were located at Nha Trang. The second helicopter platoon was located at Pleiku, 120 nautical miles northeast of Nha Trang. The third and fourth helicopter platoons plus the operations section of the flight operations platoon were collocated at Qui Nhon, 93 nautical miles north of Nha Trang.

##### b. Company Operations

#### (1) Company Headquarters

(a) Command and control and administrative functions were provided by the company headquarters. Since the helicopter platoons were deployed great distances from the company base and beyond the range capability of authorized communication equipment, considerable difficulty was experienced in providing effective command and control by company headquarters. Coordination and command direction was accomplished by visits to the helicopter platoon locations and through weekly conferences. All platoon leaders met weekly with the unit commander to discuss support requirements, past activities, and mission requirements.



The method of employment increased the administrative workload of each helicopter platoon. Company headquarters consolidated and forwarded all reports and correspondence. However, feeder reports, duty rosters, log books, staff journals, and personnel actions were initiated and maintained by platoon administrative sections. These sections were established from resources within the platoon.

(b) Although the normal supply function was provided by company headquarters, deployed helicopter platoons were required to maintain a small supply section to account for platoon equipment. This section also obtained expendables from the local supply depot.

## (2) Flight Operations Platoon

(a) The flight operations platoon consisted of a platoon headquarters, operations section, and communications section. The platoon was located with the company headquarters at Nha Trang. Because of the wide dispersal of the helicopter platoons and lack of responsive communications, the operations platoon was unable to perform its primary function of planning and directing company operations.

(b) Except for a few company activities, which the operations platoon coordinated with supported units and agencies, most platoon activities were confined to consolidating and maintaining evacuation statistics, preparing reports for the company commander and higher headquarters, weapons and survival training, maintaining individual aviator flight records, and processing recommendations for awards and decorations.

(c) The operations section did not operate a heliport at any of the company locations. Personnel from this section were provided to the helicopter platoons to assist in establishing platoon operations sections.

(d) The communications section operated a field telephone system for elements of the company located at Nha Trang. They also operated a high frequency, single sideband (HF/SSB) radio for communicating with the deployed helicopter platoons. This radio, obtained during the latter part of the evaluation, was a commercial model that proved to be unreliable due to high temperatures and humidity. However, it was used occasionally to receive reports from the helicopter platoons.

## (3) Maintenance Platoon

(a) To accomplish organizational aircraft maintenance

the maintenance platoon was organized employed as described in FM 8-16. It was composed of a headquarters element, four aircraft maintenance sections, and an airfield service section. The maintenance sections, each augmented by an aircraft refueling specialist and a crash rescue specialist from the airfield service section, were deployed with each of the helicopter platoons. A number of helicopter mechanics from these sections were retained at platoon headquarters to provide a centralized periodic aircraft maintenance inspection capability. Under supervision of the maintenance platoon leader, these mechanics performed periodic inspections on all company aircraft. Other platoon personnel operating away from platoon headquarters consisted of two aviation electronic repairmen. One repairman was assigned to the maintenance section located at Qui Nhon and the other to the maintenance section at Pleiku. In addition, one technical inspector and one aircraft parts specialist were assigned to the consolidated 3d and 4th Helicopter Platoons at Qui Nhon.

(b) At Qui Nhon the two maintenance sections were consolidated and supervised directly by the senior maintenance section sergeant and one aviator, who was assigned the additional duty as maintenance officer. An aviator in the 1st and 2d Helicopter Platoons was also assigned the additional duty of platoon aircraft maintenance officer. The maintenance platoon leader had no direct supervisory control over these detached maintenance sections.

(c) The crash rescue element of the airfield service section was not established during the evaluation period. Crash rescue service was provided to all elements of the company by the host unit operating the airfield on which the helicopter platoons were tenants.

(d) No requirement existed to maintain GCA equipment during the evaluation period. The GCA equipment was transferred to the 125th Air Traffic Control Company prior to the beginning of the evaluation.

#### (4) Helicopter Platoon Operations

(a) Helicopter platoon operations, often referred to as "Dust Off" operations, provided medical evacuation general support from platoon bases to all US/FWMAF operating within each of the platoon areas of responsibility on an on-call basis. Requests for evacuation were received by the helicopter platoons through various means. The platoons monitored a specific FM radio frequency at all times; American Special Forces units advising Vietnamese Civilian Irregular Defense Groups (CIDG) contacted the platoons on this frequency. Other US units requested patient evacuation through medical channels. In general these requests were routed to the medical clearing facility supporting the combat brigade. Located with the clearing facility was a medical regulating officer (MRO) from the medical group responsible for the field army level medical support in the area. This MRO had direct contact with a medical group MRO through an HF/SSB radio. Requests were routed to the medical group from the clearing facility through an MRO in the field. The group then

passed on the request, most often by telephone to the nearest helicopter platoon operations section. An explanation of the interrelationships among various elements of the aeromedical evacuation process and a description of aeromedical system interfaces with other elements are given in annex A.

(b) Valuable assistance to helicopter platoon crews was provided by US ground units at pickup sites. Radio communication between the pilot and personnel at the site was established while the aircraft was enroute. Ground personnel advised the pilot of conditions at the pickup site such as enemy activity, obstacles, wind direction and velocity, and recommended approach and departure routes. Smoke was also available, at the pilot's request, to show unit location and wind direction and velocity.

(c) The helicopter platoons also received evacuation requests through the Army Air Traffic Control System (ATCS). This system was operated by the 125th Air Traffic Control Company and provided flight following service throughout the Republic of Vietnam. Units often passed medical evacuation requirements to aircraft operating in the vicinity. These aircraft relayed the requests to the 125th ATC Company, which passed it to the nearest Dust Off platoon by FM radio. This notification method provided valuable and in several instances was instrumental in providing timely evacuation of seriously wounded US/FWMAF personnel.

(d) Republic of Korea (RCK) forces requests for medical evacuation support were received generally through one of two means. Normally, an English speaking Korean officer from the Korean medical clearing facility contacted one of the helicopter platoon operations sections by FM/radio or telephone and transmitted the evacuation request directly to Dust Off operations. In other cases the RCK evacuation requests were forwarded to the nearest Dust Off operations by the US Air Force forward air controllers (FAC) supporting ROK forces. Evacuation requests were received by the FAC ground elements either in English or Korean (interpreters were available) and relayed to the airborne USAF FAC. The airborne FAC either passed the request along through FAC channels or contacted Dust Off operations direct. This method of handling evacuation requests from RCK forces proved to be far superior to most other methods employed in support of other FWMAF. In addition the FAC often remained in the vicinity, assisted the Dust Off pilot in identifying the site, and advised him of the tactical situation and the general security of the area. This assistance proved invaluable and contributed directly to the success of "Dust Off" missions in support of ROK forces.

(e) Direct support also was provided to US/FWMAF from the platoon bases. Aeromedical evacuation support for airmobile assaults was an example of this. These support missions generally required a medical evacuation helicopter to be on an airborne station close to the assault landing zone. Once the assault was completed and patients evacuated from the landing zone the medical aircraft were released to their respective platoon bases. At this time evacuation requests were processed as described

previously. These types of missions were usually 3 to 6 hours in duration. One in support of ROK forces, however, lasted 14 days. For this mission, an aircraft was on site from the first light to last light each day. When the aircraft was not required for medical evacuation, it remained on the ground in a standby alert status at the ROK forces forward command post.

(f) The field sites used by the company were of two types: tactical and improved. (Locations of these sites are shown in figure 2). Tactical field sites were temporary sites established by the supported unit for direct support of combat operations. They varied from sites used on previous operations, to existing clearings, to areas freshly hewn out of the jungle. Improved field sites consisted of a helipad located in a relatively secure area with semi-permanent facilities. One of these was located at the 91st Evacuation Hospital at Tuy Hoa and the other at the Army airfield at Ban Me Thuot. Although none of the platoons were required to station aircraft at both of these sites simultaneously, each platoon was required at one time during the evaluation period to provide an aircraft and crew at each site, separately. Crews were generally on duty for seven days, after which they were relieved on site by a new crew.

(g) Helicopters of the 498th stationed at Ban Me Thuot evacuated all US patients in the Ban Me Thuot area to a nearby medical clearing facility operated by the 563d Medical Clearing Company. From the clearing facility patients were evacuated to the 8th Field Hospital at Khe Trang, normally by this same crew. The largest number of patients evacuated in the Ban Me Thuot area were from ARVN units and the CIDG. All ARVN and CIDG patients were evacuated to an ARVN hospital near Ban Me Thuot.

(h) At Tuy Hoa all US patients were evacuated to the clearing facility supporting combat elements operating in the area and from there to the 91st Evacuation Hospital. The ROK, ARVN, and CIDG patients were evacuated to ROK and ARVN hospitals which were located near Tuy Hoa.

(i) Field locations from which the helicopter platoons provided direct medical evacuation support for combat operations were considered tactical field sites. These varied in number during the evaluation period from a minimum of 4 to a maximum of 10. Generally, the nearest helicopter platoon provided support of these locations.

(j) During the evaluation period the 1st helicopter platoon directly supported combat operations at Phan Rang, Phan Thiet, Xuan Loc, and Khanh Duong. Medical clearing facilities were located at all of these tactical field sites. Patients were evacuated from the battle area to a clearing facility by aircraft on site, and from the clearing facility to the 9th Field Hospital by the aircraft based at Khe Trang.

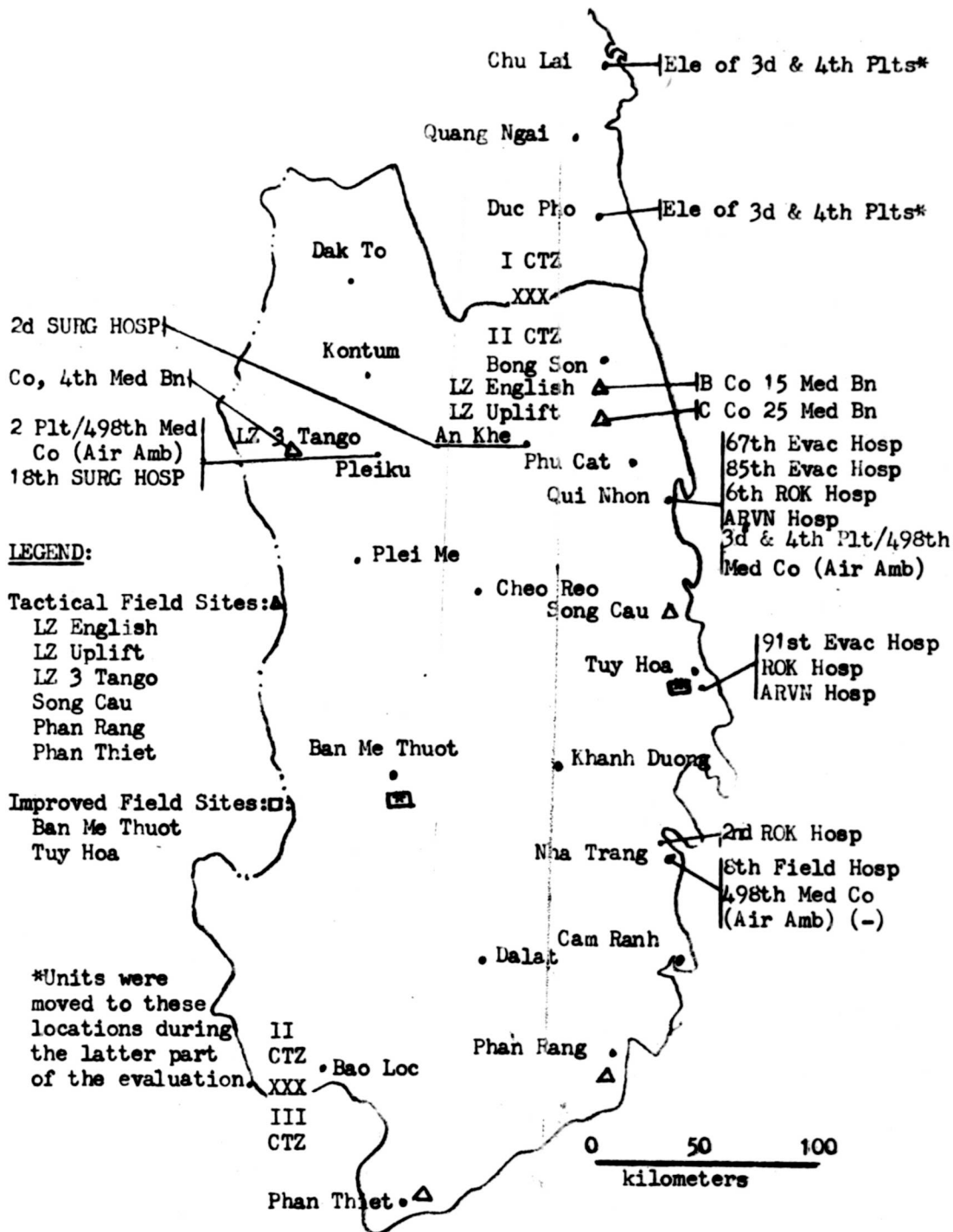

FIGURE 2 Medical Facilities and Evacuation Helicopter Field Sites, II CTZ

Patients of the ROK White Horse Division were evacuated to a ROK hospital near Nha Trang. The 1st platoon supported two to three sites simultaneously.

(k) The 2d helicopter platoon provided direct support to elements of the US 4th Infantry Division with aircraft positioned at landing zone (LZ) 3 Tango, and area support from the platoon base at Pleiku. Patients were flown from the battle area to clearing elements at LZ 3 Tango. From there, the helicopter platoon base evacuated the patients to the 18th Surgical Hospital at Pleiku. Patients were also flown from the clearing facilities and 18th Surgical Hospital to either the 67th or 85th Evacuation Hospitals at Qui Nhon. During the evaluation period the 2d platoon supported one tactical and one improved field site.

(l) The 3d and 4th helicopter platoons provided direct support to elements of the US 25th Infantry Division from LZ Uplift and to the ROK Infantry Division from Song Cau. Area support for these operations were provided from the platoon base at Qui Nhon. Patients were flown from the battle area to the clearing facilities of their respective units by the aircraft on site at the LZ. From the clearing facility US patients were evacuated by platoon based aircraft to either the 67th or 85th Evacuation Hospital at Qui Nhon. Direct support to ARVN units operating with elements of the 1st Cavalry Division (Airmobile) in the vicinity of Bong Son was provided from LZ English. The platoon evacuated patients from the ARVN and 1st Cavalry Division medical clearing stations to evacuation hospitals at Qui Nhon.

(m) Each of the helicopter platoons had two to four aircraft equipped with the internally mounted personnel hoist. Hoist operations were performed by all the platoons. The 1st and 2d platoons were called on for the greatest number of these missions. Hoist missions were flown for all categories of patients when required by the tactical situation and when a landing site was not available. Hoisting operations were critical because of excessive exposure of the helicopter to enemy fire and reduced capability of the helicopter to hover while out-of-ground effect. Existing terrain and climatic conditions further reduced the hover capability. Normally only one patient could be evacuated per sortie using this method of pick-up. As a result some hoist missions were referred to medium helicopter companies (CH-47). (A detailed description of hoist operations is presented in annex B.)

(n) Although the Geneva Red Cross was clearly and prominently displayed on all of the company's 25 helicopters, 19 of them were hit by enemy ground fire on 32 occasions. The number of hits per incident ranged from 1 to 19. Eighty percent of the hits occurred at the evacuation site. One helicopter was hit in mid-air by an enemy rocket or mortar round while performing a hoist mission. As a result of these hits the unit suffered 3 killed and 10 wounded.

(c) During the later part of the evaluation, the company received a requirement to provide aeromedical evacuation support for US forces operating in I CTZ. The mission was assigned to the 3d and 4th Helicopter platoons. Three aircraft were placed at Duc Pho, 90 miles north of Qui Nhon, and three aircraft at Chu Lai, 115 miles north of Qui Nhon. At Duc Pho, evacuation requests were transmitted from the battle area to the brigade surgeon by FM radio, then by telephone to Dust Off. Requests were also passed directly from the combat area to an airborne command and control helicopter which then relayed the request to Dust Off. All patients were evacuated to a clearing station at Duc Pho, and then to one of the evacuation hospitals at Qui Nhon. At Chu Lai evacuation requests were transmitted from the battle area to the brigade tactical operations center (TOC) by FM radio, then by telephone to Dust Off. Patients were evacuated from the battle area to brigade medical clearing, and then to the 2d Surgical Hospital at Chu Lai.

## 2. Personnel Utilization

### a. General

The deployment of the company in three separate locations required duplication of effort in administration, operations, aircraft maintenance, supply, and motor maintenance. Each of the activities were conducted by personnel from the platoon, usually as an additional duty, or by personnel from the maintenance or operations platoon who were deployed with the helicopter platoons. Company headquarters had an additional aviator as administrative officer to maintain continuity in company administration during the commander's absence and to assist in accomplishing administration. Two aviators were assigned the duty of supply officer and assistant supply officer to maintain continuity in the supply operation. The company armorer and two other enlisted men were also assigned to the supply section. During the evaluation the company mess was not established. Mess personnel were attached to a consolidated enlisted mess located on the base at Nha Trang. The average company strength during the data collection period was 32 officers, 16 warrant officers, and 179 enlisted men. Forty-seven assigned enlisted men were in excess to TOE authorization.

### b. Flight Operations Platoon

The majority of the operations platoon personnel did not work in their MOS. The primary function of the platoon was administrative; therefore, the personnel trained to operate a control tower, radar approach, and radio beacon were assigned to either clerical duties or to the helicopter platoons. One senior control tower operator was placed on duty with the Nha Trang Air Traffic Control Facility, which was operated jointly by the US and Vietnamese Air Force. The communications chief operated a limited

communication section. One aviator from the 1st helicopter platoon performed an additional duty as chief of the awards and decorations section. Two Vietnamese typists were employed by the platoon to assist in maintaining the large volume of records and reports.

#### c. Maintenance Platoon

(1) The specific operational conditions, operational locations, techniques for employing Dust Off platoons, and location of the maintenance platoon, generally dictated how personnel of the maintenance platoon would be employed to accomplish the organizational aircraft maintenance.

(2) Each of the maintenance sections, less one senior helicopter mechanic and one helicopter mechanic was deployed under operational control of a Dust Off platoon. In addition, an aircraft refueling specialist and a crash rescue specialist from the airfield service section were assigned to the deployed maintenance section. One aviation electronic equipment mechanic was assigned to the maintenance section with the 2d helicopter platoon at Pleiku and one with the consolidated maintenance sections of the 3d and 4th helicopter platoons at Qui Nhon. This consolidated maintenance section had, in addition, one technical inspector and one aircraft parts specialist assigned from platoon headquarters.

(3) The GCA equipment repairman and the remaining two aviation electronic equipment mechanics constituted an avionics section. This section performed all authorized radio and electronic equipment maintenance on aircraft in company headquarters and the 1st helicopter platoon. They also performed all authorized radio and electronic equipment maintenance that is associated with aircraft periodic inspections.

(4) The aircraft parts specialist, supply records clerk, and shop clerk constituted the aircraft parts supply section. This section requested, received, stored, and issued aircraft repair parts for the aircraft of company headquarters and the 1st helicopter platoon, and all repair parts for aircraft undergoing periodic inspections.

(5) Remaining maintenance personnel performed periodic inspections on assigned aircraft. The maintenance platoon sergeant, assisted by the airfield service section sergeant, supervised periodic inspections. The airfield service section sergeant was available for other duties as a result of the fragmentation of the airfield service section.

#### d. Helicopter Platoon

(1) The 1st helicopter platoon, located at Nha Trang Air Base, was organized into three functional sections: operations, aircraft

maintenance, and motor maintenance. These sections were operated by officers and enlisted men of the platoon. The platoon communication capability was augmented by assignment of two air traffic controllers from the operations platoon. The third radio operator was an air ambulance aidman. This assignment provided 24-hour radio operations. Driving and motor maintenance of the two assigned vehicles was performed by the air ambulance aidman. Aircraft maintenance was performed by assigned crew chiefs, assisted by personnel from the maintenance platoon. One evacuation pilot was assigned to additional duty of platoon aircraft maintenance officer. Patient protector duties were performed by the helicopter mechanics assigned to the platoon and from other elements of the company located at Nha Trang. The platoon was furnished normal airfield service support from the adjacent maintenance platoon. No supply duties were performed by the platoon due to its proximity to company headquarters.

(2) The 2d helicopter platoon, located at Pleiku, used personnel from platoon resources to operate its own operations section. This section consisted on one officer, one operations clerk, and two additional personnel to provide a 24-hour operation. Operations clerk duties were performed by an air ambulance aidman. A radio operator and crash rescue specialist occupied the other two operations positions. The supply and administrative section was assigned a supply clerk and an administrative clerk. One of the platoon aviators was assigned the additional duty of supply officer, another the duty of administrative officer, and a third the duties of motor officer. Air ambulance aidmen performed the duties of motor sergeant and drivers. The aircraft maintenance section sergeant was also the helicopter platoon sergeant. One helicopter crew chief was assigned as an assistant to the aircraft maintenance section sergeant.

(3) The 3d and 4th helicopter platoons were collocated at Qui Nhon Army airfield. To improve personnel utilization, the platoons consolidated their operations, supply, administrative, motor, and aircraft maintenance sections. The flight operations section consisted of one aviator as operations officer and four enlisted personnel. One of the enlisted men, assigned from the operations platoon, was a trained air traffic controller. The other enlisted men were air ambulance aidmen who performed operations duties in addition to duties as air ambulance aidmen. The operations section was manned on a 24-hour basis. The administrative section consisted of one aviator and one Vietnamese typist. The supply section was operated by one aviator and one supply clerk. The motor maintenance section consisted of the company motor sergeant, one helicopter mechanic's helper, and two Vietnamese mechanics. One aviator was assigned to the consolidated aircraft maintenance section as aircraft maintenance officer and test pilot. All other aspects of personnel utilization of the

**BLANK PAGE**

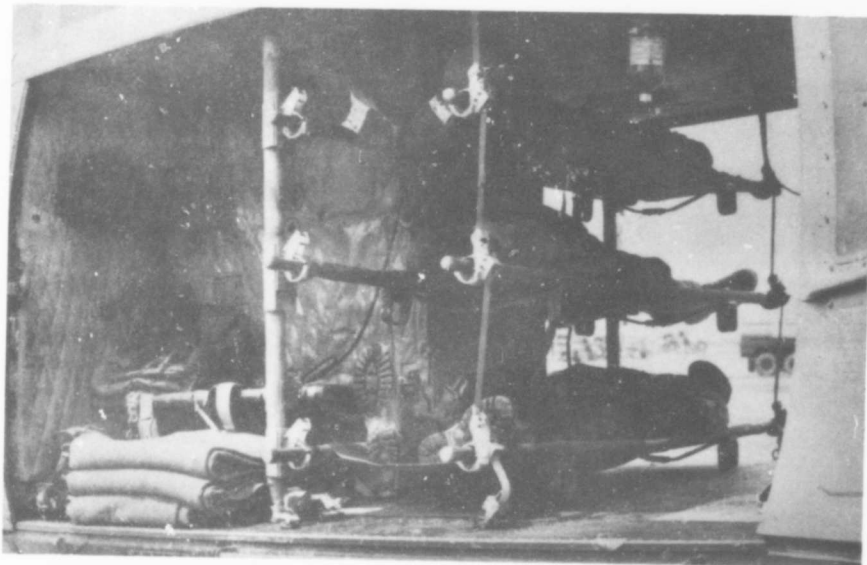

FIGURE 3. Litter configuration

arrival. The deployed helicopter platoons provided radio equipment for the operations section that each platoon maintained. All office equipment was obtained on hand receipt.



FIGURE 4. Internally mounted personnel hoist extended.

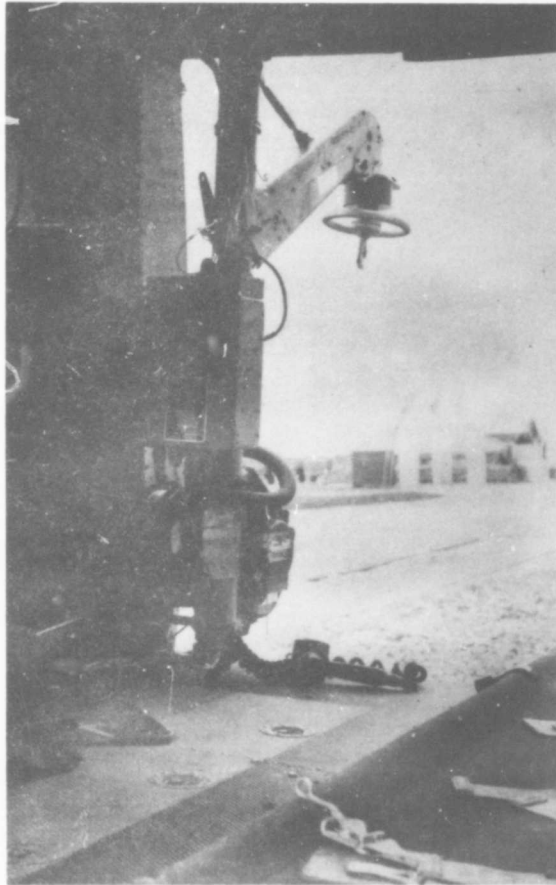

FIGURE 5. Hoist viewed from inside the helicopter.

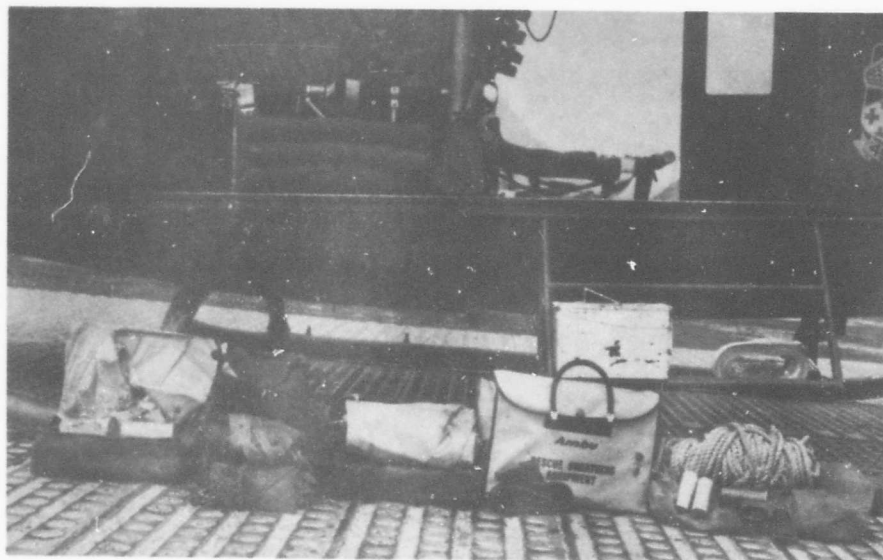

FIGURE 6. Medical treatment and survival equipment aboard evacuation helicopter. (Left to Right) Hot climate survival kit, under arm life preservers, one man life raft, rescue breathing equipment, carrying sling, 50-foot rope, parachute kit bag, tool kit, cargo tie down straps, blankets.

#### c. Maintenance Platoon

(1) The maintenance platoon used its assigned equipment during the evaluation. A Tool Set, Organizational Maintenance, Army Aircraft, Set A, and Supplement to Set A was issued to the detached maintenance sections. The maintenance sections that remained with headquarters and the 1st platoon was equipped with the Tool Set, Organizational Maintenance, Army Aircraft, Set B. This set, combined with the special tools for the UH-1D helicopters, served as a tool crib for both the 1st Helicopter Platoon and the periodic inspection team located at maintenance platoon headquarters. Some components of the Set A and supplement to Set A, which were duplicated by the consolidation of the two maintenance sections at Qui Nhon, were retained by the headquarters section of the maintenance platoon. Most of the UH-1D special tools were issued to the maintenance sections. Several of the special tools not issued to the deployed maintenance sections were made available to them by direct support transportation companies located at the Pleiku and Qui Nhon airfields. The communications equipment authorized for the airfield service section was used by the helicopter platoons. All buildings and facilities used by the platoons were either frame construction or frame type tent shelters. Therefore, no requirement existed for the maintenance platoon or section to use TOE authorized tentage or maintenance shelters. These facilities also eliminated the need for the platoon to use any of the lighting sets. All maintenance elements were located on US Army or US Air Force airfields where central power and normal operational airfield facilities were available. As a result, no use was made of the crash rescue equipment, fire fighting truck, or heliport and airfield lighting equipment.

(2) The unit was issued a 1,200 gallon fuel tanker in lieu of the authorized tank and pump units for truck and trailer mounting. Refueling was accomplished differently at each operational location. At Nha Trang all aircraft were refueled by company fuel tankers. At Pleiku all aircraft were refueled from a central refueling service operated by Holloway Army Airfield. The fuel tanker issued to the 2d Helicopter Platoon was loaned to the central refueling service. At Qui Nhon a mini-port and the company's fuel tanker were available for refueling. The mini-port was operated by Qui Nhon Army Airfield personnel. The fuel tanker was operated by airfield service section personnel assigned to the maintenance section of the 3d and 4th Helicopter Platoons.

(3) Some of the authorized electronic test equipment was used in connection with aircraft periodic maintenance inspections. Since the ground controlled approach and radio beacon equipment had been transferred, however, most of the electronic test and special power equipment was not used.

#### 4. Support

a. During the 8-week data collection period, the unit maintained a weekly average aircraft availability of 67.1 percent. These weekly averages ranged from 52.8 percent to 78.7 percent. The number of aircraft assigned to the company varied from 22 to 26.

b. The unit logged 2,806 flight hours in support of all activities. The evacuation of patients accounted for 80.1 percent of the total flying hours, of which 23.6 percent were performed during the hours of darkness. The unit evacuated 6,519\* casualties, including 62 killed in action. This required 6,378 sorties and 2,343 evacuation missions. Patient pick-up and delivery to a medical facility normally required a minimum of two sorties. The average helicopter patient load was 2.06 patients. The average flying time per sortie was 21 minutes, but the average response time (time unit received request until patient was delivered to medical facility) for the evacuation of urgent category patients was 63 minutes. Only 55 patients were evacuated by employing the internally mounted personnel hoist. The existing high density altitude conditions severely limited this type of support with the UH-1D helicopter equipped with the 1,100 shaft horse power engine. Of the total hoist extractions, 18.1 percent were conducted during the hours of darkness. The average time for each hoist mission was 1 hour and 5 minutes.

c. The company did not accomplish all of the air evacuation of patients within II CTZ. For example, patients from the 1st Cavalry Division were evacuated from the combat area to division medical clearing stations by medical helicopters organic to the division. However, the evacuation of patients from division clearing to evacuation hospitals was done by the 498th. Evacuation of patients was also done by non-medical helicopters. According to records of the 44th Medical Brigade, non-medical helicopters accounted for over 30 percent of the patients evacuated within RVN. Great distances between hospital facilities and the limited payload of the UH-1D helicopter reduced the capability of the company to transfer patients between hospitals and to provide rapid movement of mass casualties. This mission was often performed by UH Air Force in C-7 (Caribou), C123 (Provider), and C130 (Hercules) aircraft upon request of the MRO.

d. Support other than patient evacuation accounted for 14.8 percent of the total flying hours. This included combat assault coverage; search and rescue; movement of medical supplies, whole blood, and personnel; and crash rescue support for USAF defoliation missions. The unit transported 13.6 tons of medical supplies, 1,401 units of blood, and 1,781 personnel. The remaining 5.1 percent of total flying hours was for administration, training, and maintenance. (See annex C, Evacuation Missions.)

\*This number should not be construed to represent the total casualties within II CTZ for the evaluation period. Many patients were transferred within two or three medical facilities by the unit. This number represents the total casualties evacuated from all facilities and sites during the evaluation period by the 498th Medical Company (Air Ambulance).

## B. OBJECTIVE 2 - INCREASED OPERATIONAL EFFECTIVENESS

### 1. Present Methods of Employment, Organization, and Personnel and Equipment Authorizations

#### a. Employment

(1) The method for employing the 498th Medical Company generally conformed with the method described in FM 8-16. The helicopter platoons, which were widely and indefinitely separated from company headquarters and other company support, were required to assume the responsibility for flight operations, administration, aircraft and vehicle maintenance, and unit supply. In order to perform these functions it was necessary to restructure the platoons, add personnel and equipment, and change other elements of the company.

(2) The helicopter platoons at Pleiku and Qui Nhon were reorganized to cope with these added functions. Each established a flight operations section which received, coordinated, and scheduled all missions. Since most mission requirements were received directly from the supported elements, the establishment of this section was essential. Flight reports, records, log books, and a daily staff journal were maintained by this section. Administrative and vehicle maintenance section were also essential to the platoon operation.

(3) The responsibility for supervision of aircraft maintenance was assumed by the helicopter platoon. Personnel were not available from within company and platoon resources for specific assignment to these duties; they were therefore performed by platoon personnel in addition to primary assignments. In certain instances the additional duty became of prime importance and the individual's primary duty assignment became secondary. The administrative officer, operations officer, and aircraft maintenance officer of the deployed helicopter platoons are examples. The operations specialists were examples of this among the enlisted personnel. A direct correlation can be made between the time expended by platoon personnel to perform these functions and the impact of these functions on the helicopter platoons which were operating indefinitely away from the company base. The added platoon tasks were grouped into eight general work areas and the effort expended in these areas was accounted for daily and weekly. A break-out of these tasks and the daily man-hours spent by the platoons on each of them is shown in figure 7.

(4) Using figure 7, a comparison of the total additional effort expended by the 1st helicopter platoon, located with company headquarters, and that of the other helicopter platoons shows that less overall effort was expended by the 1st platoon than the others in all areas except aircraft maintenance and operations. The 2nd platoon, however, expended more effort than the 1st platoon in all areas and more than the 3d and 4th platoons, if treated separately, in five of the eight areas. Annex D discusses additional duties in detail.

| DAILY MAN-HOURS PER PLATOON |       |        |              |       |
|-----------------------------|-------|--------|--------------|-------|
| TASKS                       | FIRST | SECOND | THIRD/FOURTH | TOTAL |
| Clerical and Administrative | 3.3   | 12.1   | 14.6         | 30.0  |
| Aircraft Maintenance        | 10.6  | 18.4   | 13.6         | 42.6  |
| Vehicle Maintenance         | 2.3   | 4.7    | 13.6         | 20.6  |
| Other Maintenance           | 3.5   | 4.2    | 8.0          | 15.7  |
| Security                    | 0.0   | 38.2   | 11.5         | 49.7  |
| Area Improvement            | 3.8   | 7.0    | 31.9         | 42.7  |
| Supply                      | 0.0   | 4.0    | 11.7         | 15.7  |
| Operations                  | 32.0  | 34.0   | 36.0         | 102.0 |
| TOTALS                      | 55.5  | 122.6  | 140.9        | 319.0 |
| Average per day             | 6.9   | 15.3   | 17.6         |       |

FIGURE 7. Daily man-hours per area spent on additional duty in the helicopter platoons.

(5) The mission and capabilities of the operations and maintenance platoons were reduced considerably as a result of the company's method of employment. Three of the four aircraft maintenance sections that were attached to the helicopter platoons at Qui Nhon and Pleiku became an integral part of these platoons and were completely divorced from the maintenance platoon. The capability of the maintenance platoon was reduced to one-fourth of its total capability and its mission reduced to performing periodic maintenance inspections and maintenance associated therewith. Scheduling of aircraft flight time for maintenance purposes was accomplished within each platoon. Thus, the maintenance platoon leader had little or no control over this schedule. The company was informed of the time remaining to inspection on all company aircraft by means of an aircraft status report that was transmitted daily by each helicopter platoon. Normally this report was made by

either radio or telephone. Sometimes, reports were sent through the message center. Reports sent in this manner normally required 2 to 3 days to reach company headquarters.

(6) The capability of the flight operations platoon to establish and operate a heliport and instrument landing facility has not been required since arrival of the company in RVN. There is no requirement in the foreseeable future for the company to use this capability.

(7) Due to wide separation of the helicopter platoons from the operations platoon, the mission of coordinating and directing operational activities was delegated to the helicopter platoons for their respective areas of operation. Except for aircraft periodic maintenance inspections, the platoons at Qui Nhon and Pleiku operated independently. This method of employment imposed a definite limitation on the company commander's ability to exercise command and control over the deployed platoons. Command visits and conferences were the only feasible method of exercising command supervision. Most operational requirements were transmitted directly to the helicopter platoons where they were coordinated and accomplished with total independence from the headquarters and operations platoon. A daily operational status report informed company headquarters of the platoons' previous days activities. Again, communication difficulties often resulted in late reports.

(8) The geographical size of the area of operations, the troop strength supported, and the fact that this unit was the only air ambulance unit (exclusive of the medical air evacuation capability of the 15th Medical Battalion, 1st Cavalry Division) operating in the II CTZ, are factors that bore heavily on the overall operational capability of the unit.

(9) A reduction in capability and flexibility was experienced by all elements of the company. Resources of the unit were dispersed over the II CTZ at three widely separated locations. Platoon aircraft were not all flyable at one time. For example, during the 8-week data collection period when the company collectively averaged 16 aircraft available each day, the 1st platoon, with 6 aircraft assigned, could only provide an average of 4 flyable aircraft per day with the range varying from 2 to 5. The 2d platoon, with 6 aircraft assigned, averaged 4 flyable aircraft with a range of 2 to 5. The consolidated 3d and 4th platoon, with 12 aircraft assigned, provided an average of 8 flyable aircraft with a range from 6 to 11. Poor communications between the company headquarters and the deployment elements of the company, coupled with the wide separation between deployed elements, precluded the most efficient use of the company's total resources.

(10) To provide an organization that is capable of deploying helicopter platoons away from company support for extended periods of time would require major changes in organization, personnel, and equipment for all elements of the company. The mission of the maintenance platoon would be drastically reduced and be assumed by the helicopter platoons.

The helicopter platoons would require additional personnel and equipment to allow them to be self-sustaining.

b. Organization

(1) The present organization of the 498th Medical Company (Air Ambulance) is discussed in detail in objective 1. It is graphically presented in figure 8 to illustrate the impact of the method of employment on the organization of the unit and the show the shift of responsibility to the helicopter platoons for functions that would normally be performed by company headquarters, the operations platoon, and the maintenance platoon. As seen in figure 8, the near total shift of these responsibilities resulted in an organization that functionally resembled the organization of the Medical Helicopter Ambulance Detachment, TOE 8-500D, Team RA. (See figure 9.) This cellular unit, equipped and staffed to operate separately, is more adaptable for employment at specific locations where a continuing aeromedical evacuation requirement exists than is the augmented helicopter platoon of the medical air ambulance company.

(2) The medical company (air ambulance) can utilize its resources more efficiently when mission requirements and the tactical situation permit a basically centralized employment in which all elements of the company are based at one location and platoons or sections are deployed to distant points for limited periods of time. Mission accomplishment in counterinsurgency operations, however, may require decentralized employment for extended periods of time. When Medical Helicopter Ambulance Detachments, TOE 8-500D, Team RA are not available to provide a decentralized capability, the medical air ambulance company should be capable of deploying at least two helicopter platoons with supporting elements to distant and separate points for indefinite periods of time.

c. Personnel

(1) The overall personnel authorizations of TOE 8-137, series E or G, require adjustment when the medical air ambulance company is in support of combat operations. Operations in RVN required additional personnel in each element of the company except the flight operations platoon. The personnel requirements of the operations platoon were reduced by deleting the air traffic control section. All other elements and sub-elements of the company required additional personnel for efficient operation. Aviators of the 1st helicopter platoon were assigned additional duties that encompassed company-wide responsibility. Examples of these duties were:

- (a) Standardization pilot and instructor pilot
- (b) Administration officer
- (c) Supply officer

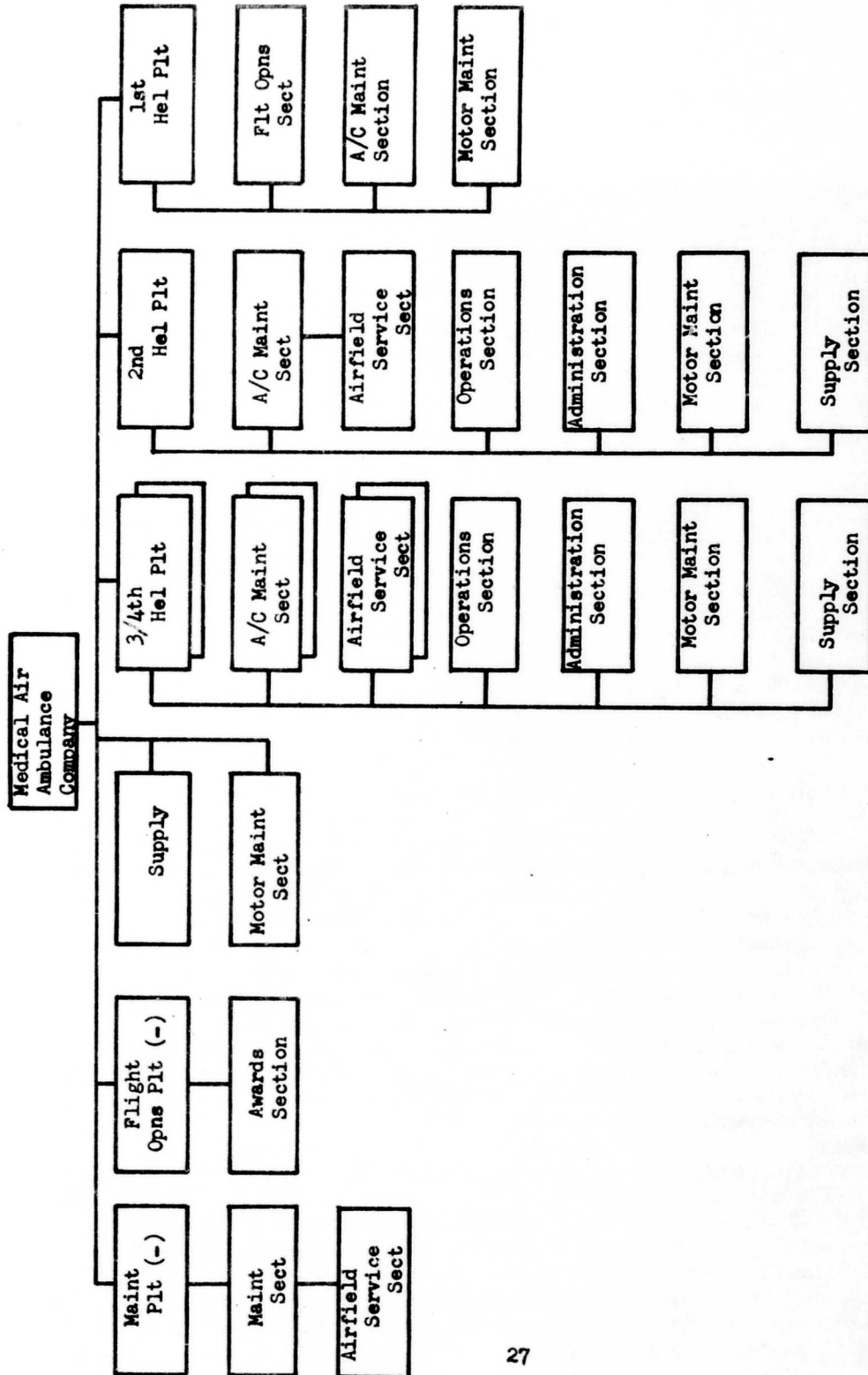

FIGURE 8. Current functional organizational structure of the 498th Medical Company (Air Ambulance).

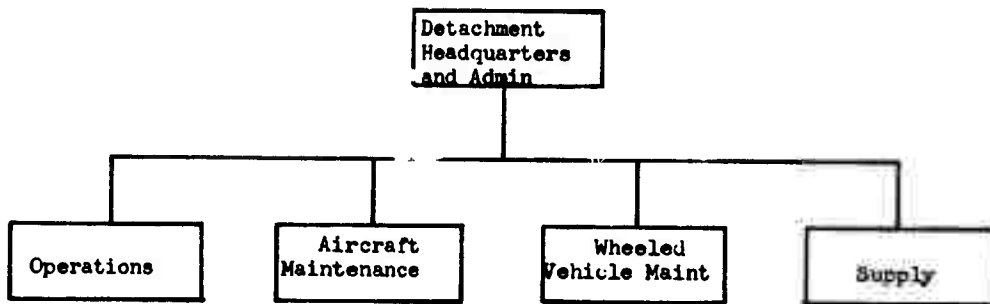

FIGURE 9. Organizational structure of the Medical Helicopter Ambulance Detachment, TOE 8-500D, Team KA.

- (d) Motor officer
- (e) Awards and decorations officer
- (f) Aviation safety officer

(2) The medical air ambulance company, operating under TOE 8-137E, was authorized, by special authority, sufficient aviator personnel to provide two aviators per aircraft. This assignment criterion is considered imperative for combat operations. TOE 8-137G provides for aviator assignment based on this criterion. Forty-seven enlisted personnel, of varying military occupational specialties (MOS), were assigned in excess of TOE. These personnel, although in excess of authorizations, were not in excess of requirements. Their duty assignments generally were compatible with their MOS. These included administrative and supply clerks, and aircraft, vehicle, and power generator mechanics. (Detailed personnel requirements are included in the discussion of the present method of employment and in annex D.)

#### d. Equipment

A full evaluation of all TOE equipment was not possible. Many items of equipment were not used and some items were turned in or stored. Climatic conditions precluded the use of stoves and heaters. Semi-permanent buildings for offices and living quarters negated the requirement for tentage. The static conditions under which the unit operated precluded a thorough evaluation of many major items of equipment. Although complete evaluation was not possible, all TOE items of

equipment were considered for possible addition, substitution, or deletion. Equipment changes were based on the results of an operational analysis made on the data collected.

e. Findings

(1) The method in which the 498th Medical Company (Air Ambulance) was employed in RVN restricted the unit from attaining its maximum capability and flexibility.

(2) The deployment of the helicopter platoons to three locations required these platoons to duplicate the company effort in administration, operations, aircraft maintenance, supply, and motor maintenance.

(3) The manner in which the company was employed required a reorganization of the helicopter platoons to provide for those functions that would otherwise be furnished by the company headquarters, maintenance platoon, and operations platoon.

(4) Increased personnel requirements resulted from duplication of the company effort by the helicopter platoons in administration, operations, aircraft maintenance, supply, and motor maintenance.

(5) The organization of helicopter platoons, which were permanently deployed away from headquarters and other company support, closely resembled the organization of the medical helicopter ambulance detachment, TCE 8-500D, Team RA.

(6) No requirement existed for the unit to operate a company heliport or establish an instrument landing facility.

2. Proposed Employment, Organization, Personnel and Equipment Changes to Improve the Operational Effectiveness of the Medical Air Ambulance Company

a. Employment

(1) Self supporting medical helicopter ambulance detachments, TCE 8-500D, Team RA, are suitable for long term deployment to widely scattered areas when mission accomplishment dictates decentralized employment of air ambulance resources. The ability to respond quickly and a thorough knowledge of the area of operations are operational requirements which often demand decentralized operations. As RA teams become available for these decentralized operations, it should then be feasible to collocate all elements of the medical air ambulance company and to deploy helicopter platoons and sections for limited periods of time only.

(2) The proposed method of employment will increase the unit's effectiveness. Consolidation of the company elements will result in restoration of command and control to the company commander and allow the operations platoon to direct and coordinate helicopter platoon activities. Aircraft maintenance, vehicle maintenance, supply, and administration could be controlled and supervised better by specific elements of the company that are equipped and staffed to perform these functions. The requirement for personnel to be assigned primary duties other than those duties associated with his position assignment would be greatly reduced and virtually eliminated with minor organizational changes of the unit. Of prime importance will be the capability of the aircraft maintenance officer to coordinate the scheduling of aircraft flight time with the operations officer. This will allow for a schedule of routine aircraft maintenance that should result in an increased aircraft availability rate. Under the present system aircraft flight time is scheduled by the helicopter platoons without coordinating with the maintenance platoon. By consolidating the maintenance sections the requirement for the helicopter platoons to engage in detailed organizational maintenance activities would be eliminated.

(3) Temporary requirements (beyond RA team capabilities) to station helicopters at various field sites to provide rapid evacuation response over large geographical areas will continue to exist. The helicopter platoons have met this requirement successfully in the past and consolidation of the company should have no adverse effect on this task. Flight sections or platoons could be tailored for specific support missions. During the latter part of the evaluation this method of operation was used in support of "Operation Oregon" at Chu Lai and Duc Pho and proved successful. Only operational aircraft were at these sites. Aircraft needing maintenance were replaced with operational aircraft from company resources. Repair of aircraft was the responsibility of the maintenance platoon.

(4) This method of employment will allow flight section personnel to devote their full time and effort to accomplishing the evacuation mission without being weighted down by other duties.

#### b. Organization

(1) The proposed organizational structure for a medical air ambulance company shown in figure 10 differs slightly from structure of the unit when organized under TOE 37G, as shown in figure 11. Other than redesignating the maintenance platoon as a service platoon, all changes took place within the platoons.

(2) The flight operations platoon has a flight operations section and a communications section. The air traffic control section, including traffic control personnel, GCA equipment, radio beacon, and allied equipment was deleted from the TOE. (See annex E.)

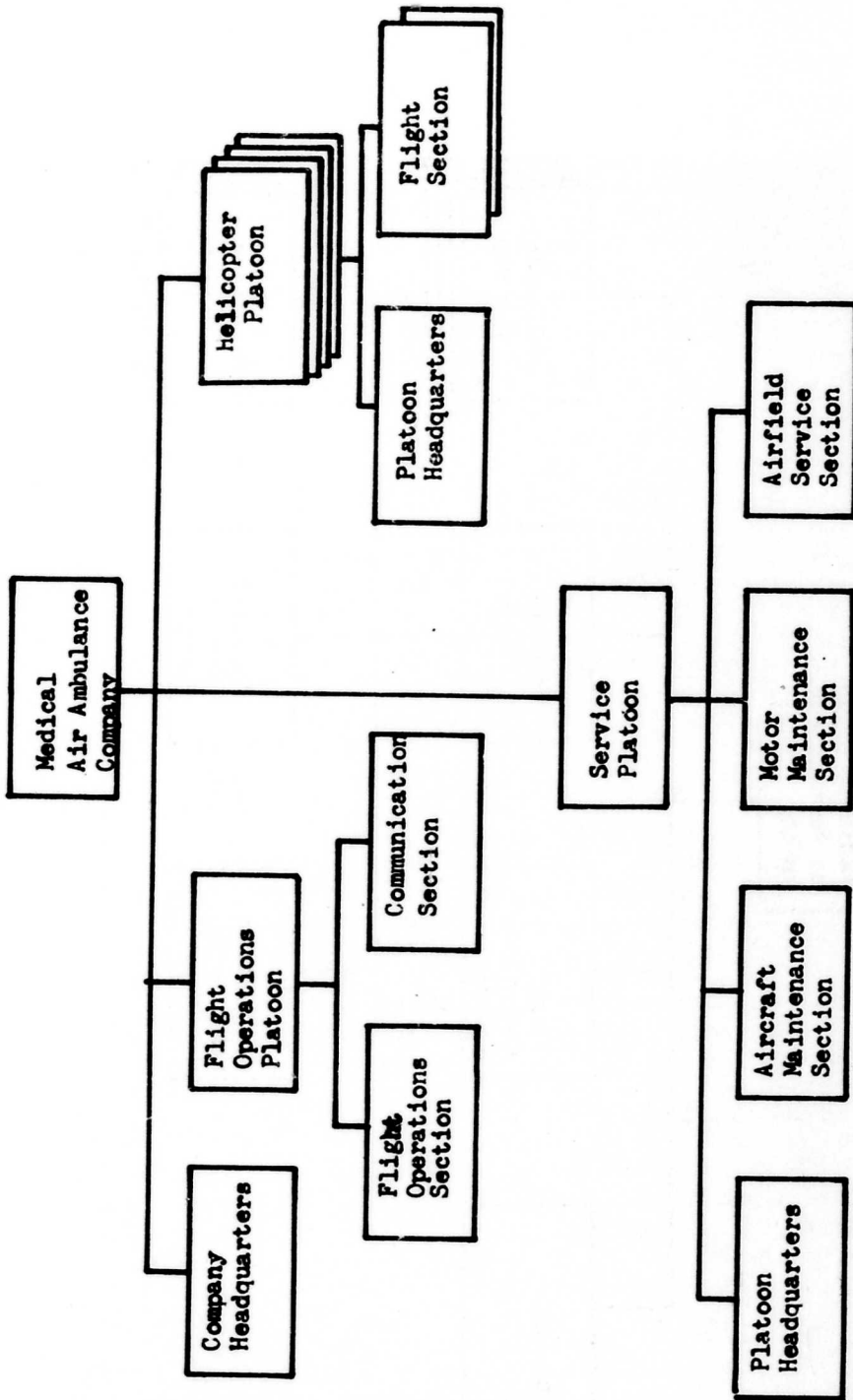

FIGURE 10. Proposed organizational structure of the Medical Company (Air Ambulance).

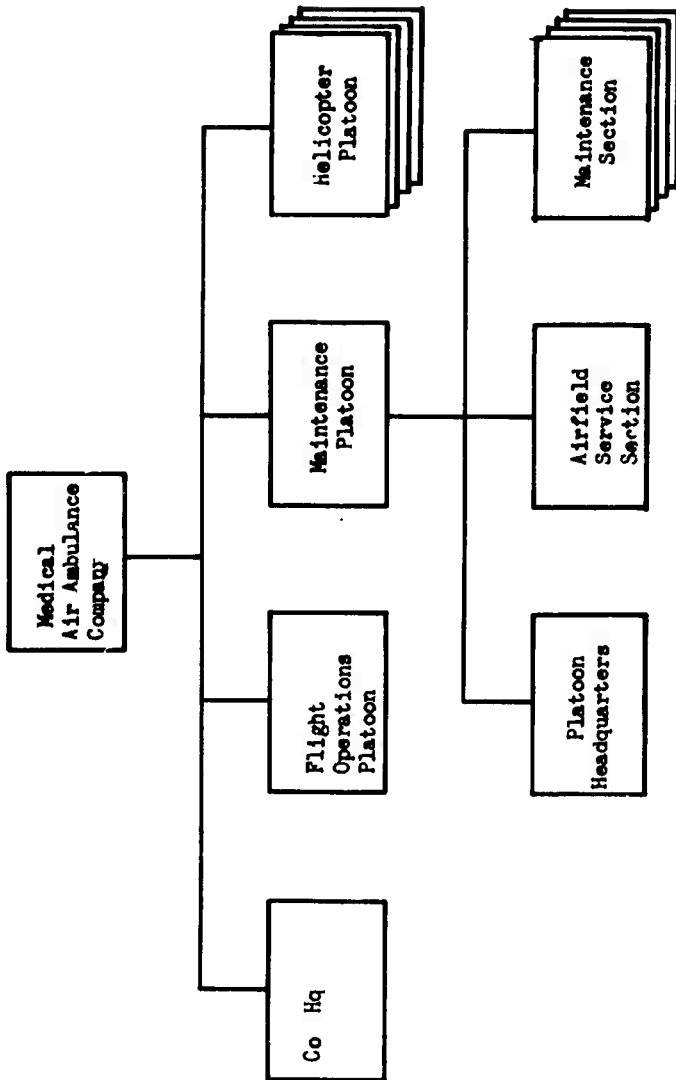

FIGURE 11. Organization of Medical Company (Air Ambulance), TOE 8-137G.

(3) The four helicopter platoons were provided a platoon headquarters in addition to the two flight sections. This organization allows for increased control by the platoon leader.

(4) The service platoon consists of a platoon headquarters, an airfield service section, a wheeled vehicle maintenance section, and a section for aircraft maintenance.

(a) The number of vehicles authorized by TOE 8-137G is 26 trucks with trailers, 2 vans, 1 wrecker, and 1 fire truck. These vehicles were maintained by motor maintenance personnel assigned to platoon headquarters. The proposed organization removes the motor maintenance personnel from platoon headquarters and places them in a separate motor maintenance section in the service platoon.

(b) A single aircraft maintenance section was formed to provide central control of aircraft maintenance activities. This section was constituted by consolidating the four aircraft maintenance sections of TOE 8-137G organization. The consolidation provides for better utilization of special tools and test equipment and more efficient use of assigned personnel. Additionally, it provides the platoon leader with the capability to form mobile maintenance teams from within the section and tailor them to meet aircraft maintenance contingencies.

c. Personnel

(1) The proposed personnel changes are applicable to TOE 8-137G and are in consonance with the proposed method of employment and organization.

(2) Company Headquarters

| (a) Add:                   | Number |
|----------------------------|--------|
| <u>1</u> Executive officer | 1      |
| <u>2</u> Supply officer    | 1      |
| <u>2</u> Clerk typists     | 3      |
| <u>4</u> Supply clerks     | 2      |

(b) Delete:

None

(c) Rationale

1 An executive officer was added to perform administrative tasks required of the headquarters. This assignment will allow

the company commander to engage in closer personal supervision of company activities and permit coordination with supported units. An executive officer is assigned to most company-size aviation units, i.e., the air cavalry troop and the airmobile company.

2 An officer is required as property book officer and for supervising unit supply activities. This officer can also assume the duties of unit mess officer. It is not necessary that this individual be a rated aviator.

3 Two clerk typists were added to assist with the company administrative and mail requirements. During the data collection period, 2,573 man hours of effort were expended in the unit orderly room by the First Sergeant, the authorized company clerk, and two additional clerks. This work requirement averaged 11 hours per man daily for the four enlisted personnel. The operations platoon was responsible for processing awards and decorations for the company. One aviator, one clerk typist, and two Vietnamese typists devoted full time to this effort. During the data collection period, 50% awards were processed. This function is more appropriately the responsibility of company headquarters. Based on this consideration, the third clerk typist was added.

4 The supply activities of the company required that three additional personnel be assigned to assist the supply sergeant. The effort expanded by these four men over the 8-week period was 2,341 man hours, or 11 hours per man per day. It is apparent that additional supply personnel are required, therefore two supply clerks were added.

(2) Flight Operations Platoon

| (a) Add:                              | Number |
|---------------------------------------|--------|
| <u>1</u> Flight Operations Clerk      | 1      |
| <u>2</u> Flight Operations Specialist | 1      |
| <u>3</u> Teletype Operator            | 1      |
| <u>4</u> Wireman                      | 1      |

| (b) Delete:                              | Number |
|--|--------|
| <u>1</u> Team Chief                      | 1      |
| <u>2</u> Senior Control Tower Operator   | 1      |
| <u>3</u> Senior Landing Control Operator | 1      |
| <u>4</u> Control Tower Operator          | 1      |

|  |   |
|--|---|
| <u>5</u> Control Tower Operator Helper | 1 |
| <u>6</u> Landing Control Operator      | 1 |

(c) Rationale

The flight operations specialist and teletype operator were added to provide 24 hour operation of the flight operations section. The flight operations clerk was added to assist in the processing of reports, evacuation statistics, charts and individual flight records for each assigned aviator and flight records of the enlisted crew members. The wireman was added to assist in the continuous operation of the communication section. Air traffic control personnel were not required and were deleted.

(3) Service Platoon

| (a) Add:  | Number |
|---|--------|
| <u>1</u> Aircraft Maintenance Technician<br>(Warrant Officer) | 1      |
| <u>2</u> Helicopter Mechanic                                  | 1      |
| <u>3</u> Helicopter Mechanic Helper                           | 2      |
| <u>4</u> Technical Inspector                                  | 1      |
| <u>5</u> Power Generator Specialist                           | 1      |
| <u>6</u> Wheeled Vehicle Mechanic                             | 1      |
| (b) Delete:   |        |
| <u>1</u> Maintenance Section Sergeant                         | 3      |
| <u>2</u> GCA Equipment Repairman                              | 1      |

(c) Rationale

1 The responsibility of the service platoon encompasses all company maintenance activities and associated supply requirements with the exception of the maintenance of weapons. The density of equipment and the growing sophistication of aircraft and aircraft equipment requires that an aircraft maintenance technician be added to the aircraft maintenance section. This assignment will provide for direct supervision of aircraft maintenance activities and allow the service platoon

leader to direct more effectively all the maintenance for which he is responsible. The warrant officer maintenance technician would also be assigned to test pilot duties. The entire maintenance program of the company would benefit from this assignment. The addition of the helicopter mechanic and two helpers will allow the aircraft maintenance technician to establish six maintenance teams consisting of two senior helicopter mechanics (one of which would act as team chief), three helicopter mechanics, and one helicopter mechanic's helper. These six teams would be supervised by the maintenance section sergeant.

2 Throughout the evaluation period the requirements for technical inspections greatly exceeded the capability of the two technical inspectors. Assistance was occasionally provided by the Transportation Company (DS) which provided direct support maintenance to the company. One technical inspector (TI) was added to cope with the increased TI requirements resulting from combat support operations.

3 The power generator specialist was added to provide a 24-hour operation of the company's power generator equipment.

4 The number of wheeled vehicle mechanics was insufficient to maintain the authorized vehicles. The addition of one mechanic will overcome the mechanic shortage, if the majority of the company vehicles are centrally located.

5 The consolidation of the aircraft maintenance sections negated the requirement for three of the four maintenance section sergeants to be assigned to the service platoon. The remaining maintenance sergeant will be NCOIC of the aircraft maintenance section. The GCA equipment repairman was not required.

(4) Helicopter Platoons

| (a) Add:                  | MOS   | Number |
|---------------------------|-------|--------|
| <u>1</u> Platoon Sergeant | 67N40 | 4      |
| <u>2</u> Radio Operator   | 91A10 | 4      |
| (b) Delete:               |       |        |
| None                      |       |        |
| (c) Rationale             |       |        |

1 A platoon sergeant was added to each helicopter platoon to supervise enlisted personnel of the platoon and to provide continuity of platoon maintenance and operations. The military occupational

specialty 67N40 was chosen because of aircraft maintenance knowledge required.

2 A radio operator added to each helicopter platoon will provide the capability of 24-hour ground-to-air communications.

d. Equipment

(1) The proposed equipment changes are applicable to TOE 8-137G and are in consonance with the proposed method of employment, organizational structure, and personnel authorizations

(2) Company Headquarters

| (a) Add: | Quantity |
|----------|----------|
|----------|----------|

|                              |   |
|------------------------------|---|
| <u>1</u> Duplicating Machine | 1 |
|------------------------------|---|

|  |   |
|--|---|
| <u>2</u> Typewriter, non-portable, 13-inch carriage w/case | 2 |
|--|---|

(b) Delete:

None

(c) Rationale

1 One duplicating machine is required for the reproduction of schedules, reports, plans, and orders. The volume required makes it impractical to depend on higher headquarters for reproduction service.

2 Typewriters were added to company headquarters for the additional clerk-typists. These typewriters are required for the timely processing of the administrative requirements of the company and for processing of decorations and awards.

(3) Flight Operations Platoon

| (a) Add: | Quantity |
|----------|----------|
|----------|----------|

|   |   |
|---|---|
| <u>1</u> Machine, adding, manual and electric | 1 |
|---|---|

|  |   |
|--|---|
| <u>2</u> radio, High Frequency, Single Sideband AN/GRC-106 | 1 |
|--|---|

|   |   |
|---|---|
| <u>3</u> Typewriter, non-portable 13 inch carriage w/case | 1 |
|---|---|

| (b) Delete:                                 | Quantity |
|---|----------|
| <u>1</u> Beacon Set, Radio AN/GRN-6 w/equip | 1        |
| <u>2</u> Generator Set Gas Engine 400 cy    | 1        |
| <u>3</u> Power Supply PP-2953/v             | 1        |
| <u>4</u> Radar Set, AN/TPN-8 w/equipment    | 1        |

(c) Rationale

1 The operations platoon has a definite requirement for an adding machine. The unit has over 50 aviators assigned and is required to maintain an accurate individual aviator flight record for each one. Monthly flight time is also maintained for enlisted personnel on flight status.

2 The requirement exists to have a communications capability beyond that afforded by authorized FM radio equipment. Based on the contingency that helicopter platoons or elements thereof may be required to operate great distances from the company for limited periods of time, and the necessity for these elements to maintain radio communication with company headquarters, provisions should be made to equip the company with HF/SSB radios to provide this communications capability. This would also provide the operations officer with a radio communications capability to net with the high frequency radios of infantry and armor units.

3 The typewriter was added for the increased administrative work load resulting from the increased authorization of aviator personnel.

4 The Beacon Set, AN/GRN-6, Radar Set, AN/TPN-8 and Power Supply PP-2953/v were deleted as not required.

5 The Generator Set, gasoline engine, 400cy, is not required. This is the power supply for the Radar Set, AN/TPN-8.

(4) Service Platoon

| (a) Add:  | Quantity |
|---|----------|
| <u>1</u> Tool Kit, Aircraft Inspection<br>Technical | 1        |
| <u>2</u> Tool Kit, Aircraft Mechanics,<br>General   | 3        |

|          |   |   |
|----------|---|---|
| <u>3</u> | Tool Kit, Automotive Mechanics, Lightweight       | 1 |
| <u>4</u> | Typewriter, Non-Portable, 13 inch Carriage w/case | 1 |
| <u>5</u> | Wrecker, 5-ton, w/e                               | 1 |
| <u>6</u> | Carrier Light Weapons, M274 w/tera tires          | 2 |
| <u>7</u> | Vacuum Cleaners, Industrial Type                  | 2 |

(b) Delete:

|           |  |   |
|-----------|--|---|
| <u>1</u>  | Cabinet, Tool and Spare Parts                                      | 1 |
| <u>2</u>  | Multimeter, AN/PRM-15  | 1 |
| <u>3</u>  | Oscilloscope, AN/USM-50  | 1 |
| <u>4</u>  | Test Set, Radar, TS-488/VP   | 1 |
| <u>5</u>  | Tool Kit, Radar and Radio RPM                                      | 1 |
| <u>6</u>  | Tool Set, Organizational Maintenance, Army Aircraft, Set A         | 1 |
| <u>7</u>  | Tool Set, Organizational Maintenance, Army Aircraft, Set A (Suppl) | 1 |
| <u>8</u>  | Trailer Cargo, 1½-ton, 2 wheel w/e                                 | 1 |
| <u>9</u>  | Truck, Cargo, 2½-ton, 6x6 w/winch, w/e                             | 1 |
| <u>10</u> | Forced Entry and Rescue Equipment Set; Aircraft Crash              | 1 |
| <u>11</u> | Truck, Utility, ½-ton 4x4, w/trailer                               | 4 |
| <u>12</u> | Radio set, AN/VRC-46, Vehicle Mounted                              | 4 |
| <u>13</u> | Wrecker, 2½-ton, w/e   | 1 |

(c) Rationale

1 The tool kits are added for the additional maintenance personnel of the service platoon i.e., one technical inspector, one helicopter mechanic, two helicopter mechanics helpers, and one wheeled vehicle mechanic.

2 A typewriter is needed for the motor maintenance section, the aircraft maintenance section, and the repair parts supply of the service platoon headquarters. Two are authorized by TOE 8-137G. One more is added here.

3 The 5-ton wrecker was added to replace the 2½-ton wrecker. The 2½-ton wrecker is considered to be too light for the quantity, size, and weight of the authorized vehicles, e.g., fuel tankers. The aircraft maintenance section would also benefit by this piece of equipment for the removal and replacement of major aircraft components.

4 Two light weapons carriers ("mule") were added to the airfield service section for carrying the forced entry and rescue kits.

5 Vacuum cleaners were added for cleaning aircraft. One authorized as component of tool set B is insufficient for 25 aircraft.

6 The multimeter, AN/RPM-15; oscilloscope, AN/USM-50; test set, radar, TS-488/VP; and the tool kit, radar and radio repairman, are deleted. There is no requirement for this equipment after the deletion of the radar set and beacon set.

7 Tool Sets, Organizational Maintenance Army Aircraft, Set A, and Set A Supplemental, and the spare parts cabinet were deleted based on consolidation of the aircraft maintenance sections. The aircraft maintenance section would now be authorized two tool sets, for organizational maintenance, Set A, two Sets A supplemental, two spare parts cabinets, and one tool set for organizational maintenance of Army aircraft, Set B. This authorization is considered adequate for the maintenance of 25 aircraft. Sufficient tools are authorized to equip tailored maintenance teams, if required.

8 The 2½-ton truck with trailer was not required as a result of the consolidation of the maintenance section and the reduction of tool sets in the aircraft maintenance section.

9 One forced entry and rescue kit was deleted. The consolidation of the service platoon would make this equipment excess.

10 The four trucks, utility with trailers, and AN/VRC-46 radios were deleted from the airfield service section and transferred to the helicopter platoons.

11 Wrecker, 2½-ton was replaced by the 5-ton wrecker.

(5) Helicopter Platoons

| (a) Add:  | Quantity |
|---|----------|
| <u>1</u> Harness Assembly, Aircraft Safety, Personnel Retaining, Type LA1 | 24       |
| <u>2</u> Hoist, Personnel, Helicopter Internally mounted                  | 24       |
| <u>3</u> Radio Set, high Frequency Single Sideband, AN/GRC-106            | 4        |
| <u>4</u> Radio Set, AN/VRC-46 Mounted in $\frac{1}{2}$ -ton Truck         | 4        |
| <u>5</u> Truck Utility, $\frac{1}{2}$ -ton 4x4 w/trailer w/e              | 4        |
| <u>6</u> Telephone Set, TA-312PT  | 4        |

(b) Delete:

|   |    |
|---|----|
| <u>1</u> Refrigerator, Hermetic                     | 8  |
| <u>2</u> Sling, Carrying Universal, Individual Load | 24 |
| <u>3</u> Splint Set: Telescopic Splints             | 24 |

(c) Rationale

1 The harness assembly was added to replace the universal carrying sling. The harness assembly is designed for crew safety and is equipped with a quick release. When the helicopter is configured for three litter patients the air ambulance aidman is without an easily accessible seat that can be equipped with a seat belt. This harness would allow him freedom of movement within the cabin area and provide adequate safety in lieu of a seat belt. The same harness could be used during hoist operations for crew safety.

2 The personnel hoist should be issued on the basis of one per aircraft. Each aircraft should be modified to accept the hoist. Installation of the hoist should be at the commander's discretion.

3 All radio equipment authorized in the helicopter platoons are "line-of-sight" type radios. These will not provide reliable communications between the helicopter platoons and the aircraft at distant field sites due to terrain and distance. The addition of an HF/SQB radio

to each platoon will improve the communication link between the aircraft and the helicopter platoons. The aircraft will be equipped with HF/SSB radio equipment.

4 The radio set AN/VRC-46 was added to augment the FM communications capability of the helicopter platoons. Each flight section should be provided a vehicle mounted FM radio transmitter. The equipment was assigned to the airfield service section by TOE 8-137G. In practice, it was used by the helicopter platoon.

5 A utility truck is required by the helicopter platoons for routine administrative and logistical transportation requirements and to provide transportation for the evacuation alert crew. This equipment was assigned to the airfield service section by TOE 8-137G. In practice it was used by the helicopter platoon.

6 A telephone set was added to provide a telephone for each of the flight sections.

7 The refrigerators were not used during the evaluation. They were presumably authorized for the temporary storage of whole blood and biologicals which might require refrigeration. Whole blood is shipped in styroform containers and packed with dry ice. No refrigeration is required. The helicopter platoon personnel have neither the time nor the training required to maintain perishable biologicals.

8 There is no use for the universal carrying sling within the helicopter platoon. If used as a retaining strap for the crew, it is a hazard. The strap is not equipped with a quick release. It was replaced by the harness assembly, aircraft safety personnel.

9 At no time did the helicopter platoons use the telescopic splints, nor was property exchange required for this item of equipment. Since exchange of this item was not required and added weight to the helicopter is of continuing concern, this item was deleted.

(6) Recapitulation of Equipment Changes

| (a) Added Equipment  | Quantity |
|--|----------|
| <u>1</u> Electronics Command                                       |          |
| <u>a</u> Radio set, High Frequency,<br>Single Sideband, AN/GRC-106 | 5        |
| <u>b</u> Telephone Set, TA-312PT                                   | 4        |

2 Mobility Command

|          |   |    |
|----------|---|----|
| <u>a</u> | Carrier, Light Weapons, M274<br>w/terra tires                     | 2  |
| <u>b</u> | Harness Assembly, Aircraft Safety<br>personnel retaining, Type A1 | 24 |
| <u>c</u> | Hoist, Personnel, Helicopter<br>Internally Mounted                | 24 |
| <u>d</u> | Tool Kit, Aircraft Inspection,<br>Technical                       | 1  |
| <u>e</u> | Tool Kit, Aircraft Mechanic<br>General                            | 3  |
| <u>f</u> | Truck, Wrecker, 5-ton, w/e  | 1  |

3 Supply and Maintenance Command

|          |  |   |
|----------|--|---|
| <u>a</u> | Case, Field, Office Machine:<br>22½L, 13½W, 17D in. inside Dia | 4 |
| <u>b</u> | Duplicating Machine  | 1 |
| <u>c</u> | Machine, Adding, Manual and<br>Electric                        | 1 |
| <u>d</u> | Tool Kit, Automotive Mechanics<br>Lightweight                  | 1 |
| <u>e</u> | Typewriter, Non-portable, 13 in.<br>Carriage                   | 4 |
| <u>f</u> | Vacuum Cleaner, Industrial                                     | 2 |

(b) Deleted Equipment: Quantity

1 Electronics Command

|          |                             |   |
|----------|-----------------------------|---|
| <u>a</u> | Beacon Set, Radio, AN/GRN-6 | 1 |
| <u>b</u> | Multimeter, AN/PRM-15       | 1 |
| <u>c</u> | Oscilloscope, AN/USM-50     | 1 |
| <u>d</u> | Power Supply, PP-2953/v     | 1 |

|          |  |    |
|----------|--|----|
| <u>e</u> | Radar Set, AN/TPN-8  | 1  |
| <u>f</u> | Test Set, Radar, TS-488/VP   | 1  |
| <u>2</u> | Mobility Command   |    |
| <u>a</u> | Forced Entry and Rescue Equipment Set, Aircraft Crash              | 1  |
| <u>b</u> | Generator Set, 400cy   | 1  |
| <u>c</u> | Tool Kit, Radar and Radio Repairman                                | 1  |
| <u>d</u> | Tool Set, Organizational Maintenance Army Aircraft, Set A          | 1  |
| <u>e</u> | Tool Set, Organizational Maintenance Army Aircraft, Set A, (Suppl) | 1  |
| <u>f</u> | Trailer, Cargo, 1½-ton, 4 wheel, w/e                               | 1  |
| <u>g</u> | Truck, Cargo, 2½-ton, 6x6, w/Winch                                 | 1  |
| <u>h</u> | Truck Wrecker, 2½-ton 6x6 w/Winch w/e                              | 1  |
| <u>3</u> | Army Medical Services  |    |
|          | Splint Set, Telescopic Splints                                     | 24 |
| <u>4</u> | Supply and Maintenance Command                                     |    |
| <u>a</u> | Cabinet, Tool and Spare parts                                      | 1  |
| <u>b</u> | Sling, Carrying Universal Individual Load                          | 24 |
| <u>5</u> | Developmental Items  |    |
|          | Refrigerator, Hermetic   | 8  |

### III. (U) CONCLUSIONS AND RECOMMENDATIONS

#### A. CONCLUSIONS

1. The method for employing the 498th Medical Company (Air Ambulance) in RVN restricts the unit from attaining its maximum capability and flexibility.
2. The deployment of three helicopter platoons to locations away from company headquarters and other company support requires duplication of effort in administration, operations, aircraft maintenance, supply, and motor maintenance.
3. Increased personnel requirements result from duplication of the company effort.
4. All elements of the company required adjustments in organization in order to accomplish the unit mission.
5. Personnel authorizations of TOE 8-137, series E or G, require adjustment when the Medical Air Ambulance Company is in support of combat operations.
6. The organization of the helicopter platoons, which were permanently separated from headquarters and other company support, closely resembled the organization of the Medical Helicopter Ambulance Detachment, TOE 8-500D, Team RA.
7. No requirement exists to operate a company heliport or establish an instrument landing facility.
8. The size, terrain, and climatic conditions of the area of responsibility and the lift capability of the UH-1D helicopter limited the capability of the Air Ambulance Company to perform all aspects of its mission.
9. The resources of the company are not sufficient to provide adequate support for an area the size of II CTZ, RVN.
10. When the tactical situation and mission requirements permit centralized operation, the effectiveness of the medical air ambulance company can be improved by basing the entire unit at one location and employing platoons or sections at distant points as required for limited periods of time.
11. Flexibility and capability can be gained by deploying helicopter platoons and flight sections for limited periods of time rather than deploying platoons permanently.

12. The proposed organization will provide for centralized control of aircraft maintenance and centralized direction and coordination of company activities.

#### B. RECOMMENDATIONS

It is recommended that:

1. The Medical Company (Air Ambulance), be organized under TOE 8-137G as modified below:

##### a. Organization

- (1) Consolidate the aircraft maintenance sections into one section.
- (2) Provide a platoon headquarters for helicopter platoons.
- (3) Delete the air traffic control section from the operations platoon.

##### b. Personnel

- (1) Add one executive officer to the company headquarters.
- (2) Add one company supply officer to company headquarters.
- (3) Add two supply clerks to company supply.
- (4) Add three clerk typists to company headquarters.
- (5) Add two flight operations and two communications enlisted personnel to the flight operations platoon.
- (6) Delete six enlisted personnel from the air traffic control section, operations platoon.
- (7) Add one aircraft maintenance technician to the aircraft maintenance section.
- (8) Add one helicopter mechanic and two helpers to the aircraft maintenance section.
- (9) Add one aircraft technical inspector and one power generator specialist to the service platoon headquarters.
- (10) Add one wheeled vehicle mechanic to the motor maintenance section.

(11) Delete one GCA equipment repairman and three aircraft maintenance section sergeants from the aircraft maintenance section.

(12) Add one platoon sergeant and one radio operator to each of the helicopter platoons.

c. Equipment

(1) Add one HF/SSB radio to the flight operations section and one to each helicopter platoon.

(2) Add one field phone to each helicopter platoon.

(3) Substitute a five-ton wrecker for a 2½-ton wrecker in the service platoon.

(4) Add two light weapons carriers to the airfield service section.

(5) Add one personnel hoist for each assigned aircraft.

(6) Delete radar set, TPN-8 and associated test equipment.

(7) Delete beacon set, AN/GHW-6, and associated test equipment.

(8) Delete one 2½-ton truck and trailer from the aircraft maintenance section.

(9) Delete one tool set, aircraft organizational maintenance Set A and Set A Supplemental from the aircraft maintenance section.

(10) Delete eight hermetic type refrigerators from the helicopter platoons.

2. The company elements be based at one location within the II CTZ, RVN, as soon as centralized company operation is made feasible by the introduction of Helicopter Ambulance Detachments, TOE 8-500 D, Team RA.

3. The doctrine and organization contained in this report be reflected in appropriate field manuals and other training publications.

4. USACDC determine which of the proposed TOE changes should be applied to the next USACDC major revision of TOE 8-137.

5. USACDC, after review and analysis of this report, submit a position paper to the Department of the Army on the proposed organization and doctrine of the Medical Air Ambulance Company, the Medical Air Ambulance Company in RVN and for any Medical Air Ambulance Company that might be scheduled for deployment to RVN.

6. Since this evaluation was limited to the Medical Air Ambulance Company, that a follow-on evaluation of the Army Aero-Medical Evacuation System be conducted in RVN at a later date.

ANNEX A

DECISION/ACTION SEQUENCE DIAGRAM

1. The purpose of this annex is to portray graphically the patient evacuation requests and the procedures carried out by the medical helicopter platoons and medical helicopters at field sites.

2. Decision action sequence diagrams (DASD) allow a modified single thread flow analysis to be accomplished. This technique allows the two basic operations, decisions and actions, to be easily distinguished. All decisions are stated forced choice (yes or no) questions requiring answers and the consequences of each alternative are easily diagramed and traced through the system. DASD permits the identification of information interface points between different system components.

3. The method of interpreting the DASDs employed are as follows:

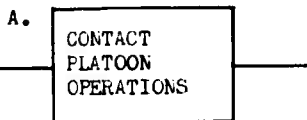

Rectangles represent an action. The specific actions are indicated by the words included inside the rectangle.

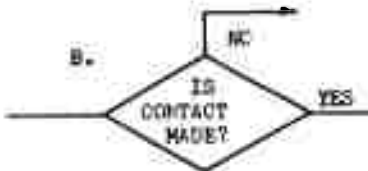

Diamonds represent a forced decision choice. The decision (question) to be made (answered) is stated within the diamond. The consequence of each and every possible answer is identified by the yes and no paths.

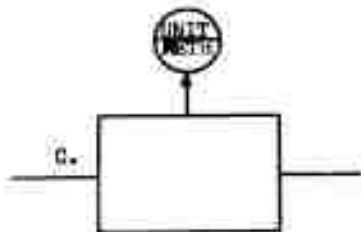

Circles entering into or exiting from action rectangles indicate interface points. The top half of the circles indicates the system, unit, element, or equipment interfaced with the bottom half of the circle indicates the method of interface.

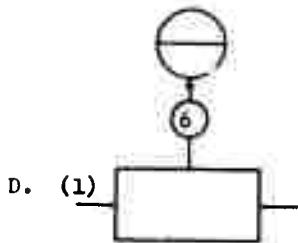

The small circles with one or more numbers inclosed and located on the interface line are used as reference marks to aid in getting back and forth between separate flows. For example, if an interface with some other system unit, or element is indicated (1), and it is desired to know where the interface occurs in other elements, then it is only necessary to find the same number in that other flow (2).

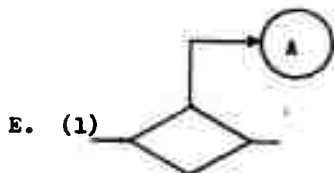
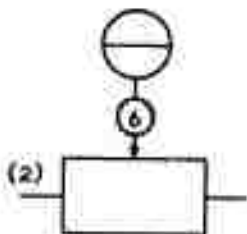

Flow reference circles with inclosed letters are used to key portions of an interrupted flow (1). To determine the proper re-entry point it is necessary to find the point at which the same letter is used to identify the flow re-entry point (2).

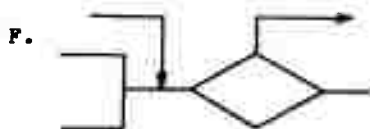
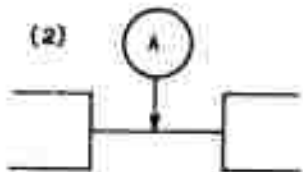

Direction of flow is always from left to right along the main flow line. Where departures from the main flow occur, arrow heads have been included to establish the proper flow direction.



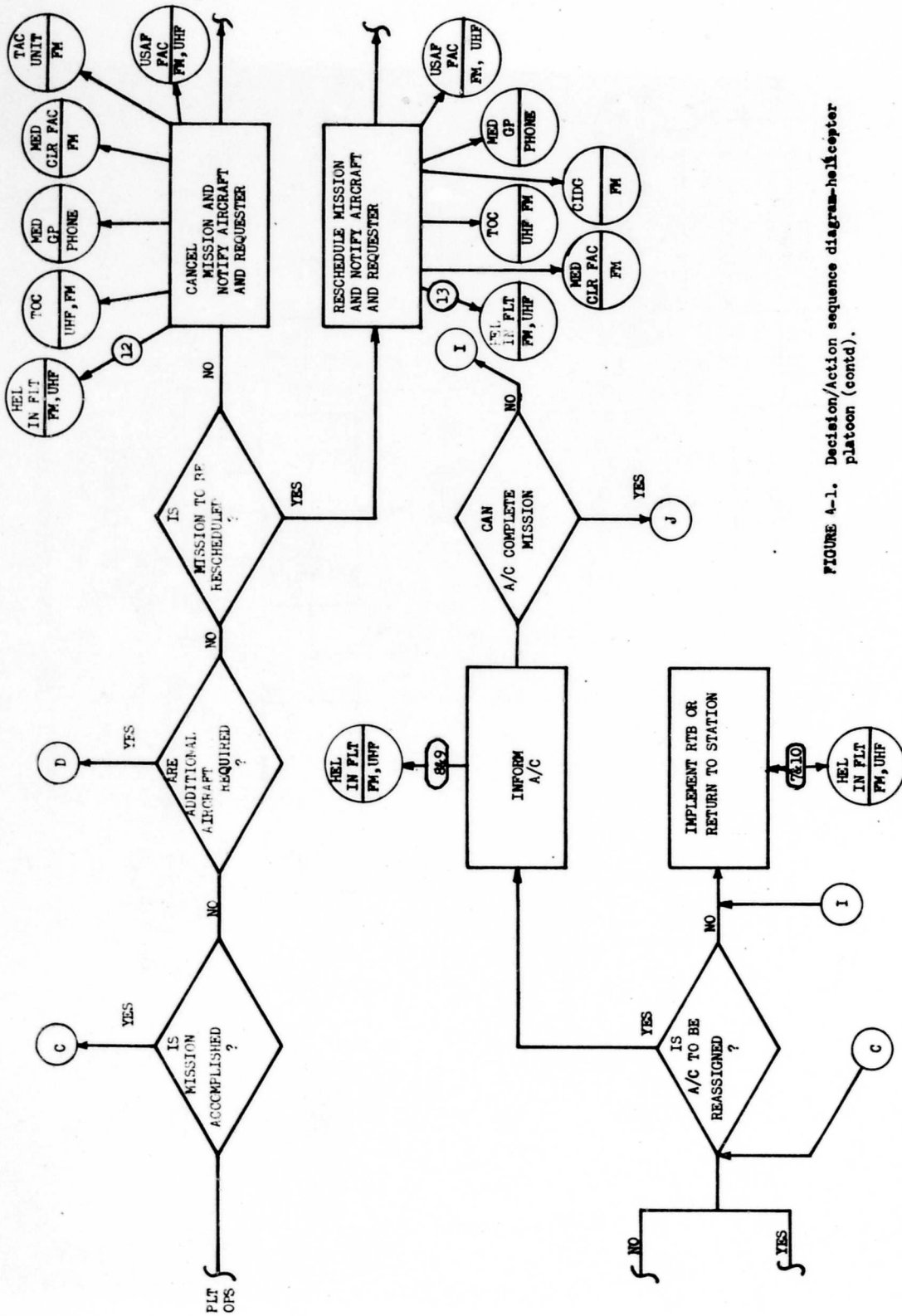

FIGURE 4-1. Decision/Action sequence diagram-helicopter platoon (contd).

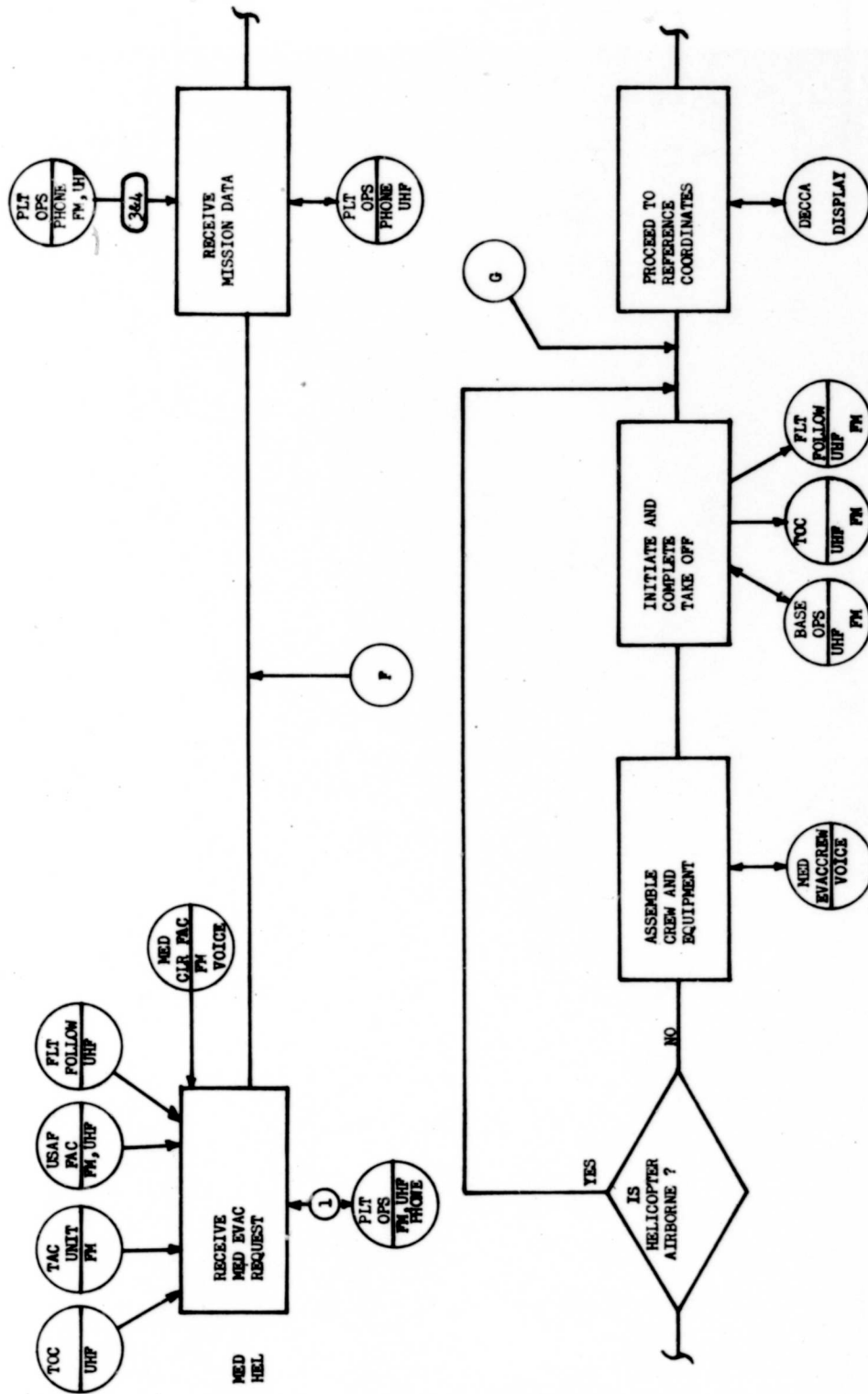

FIGURE A-2. Decision/Action sequence diagram-individual helicopter

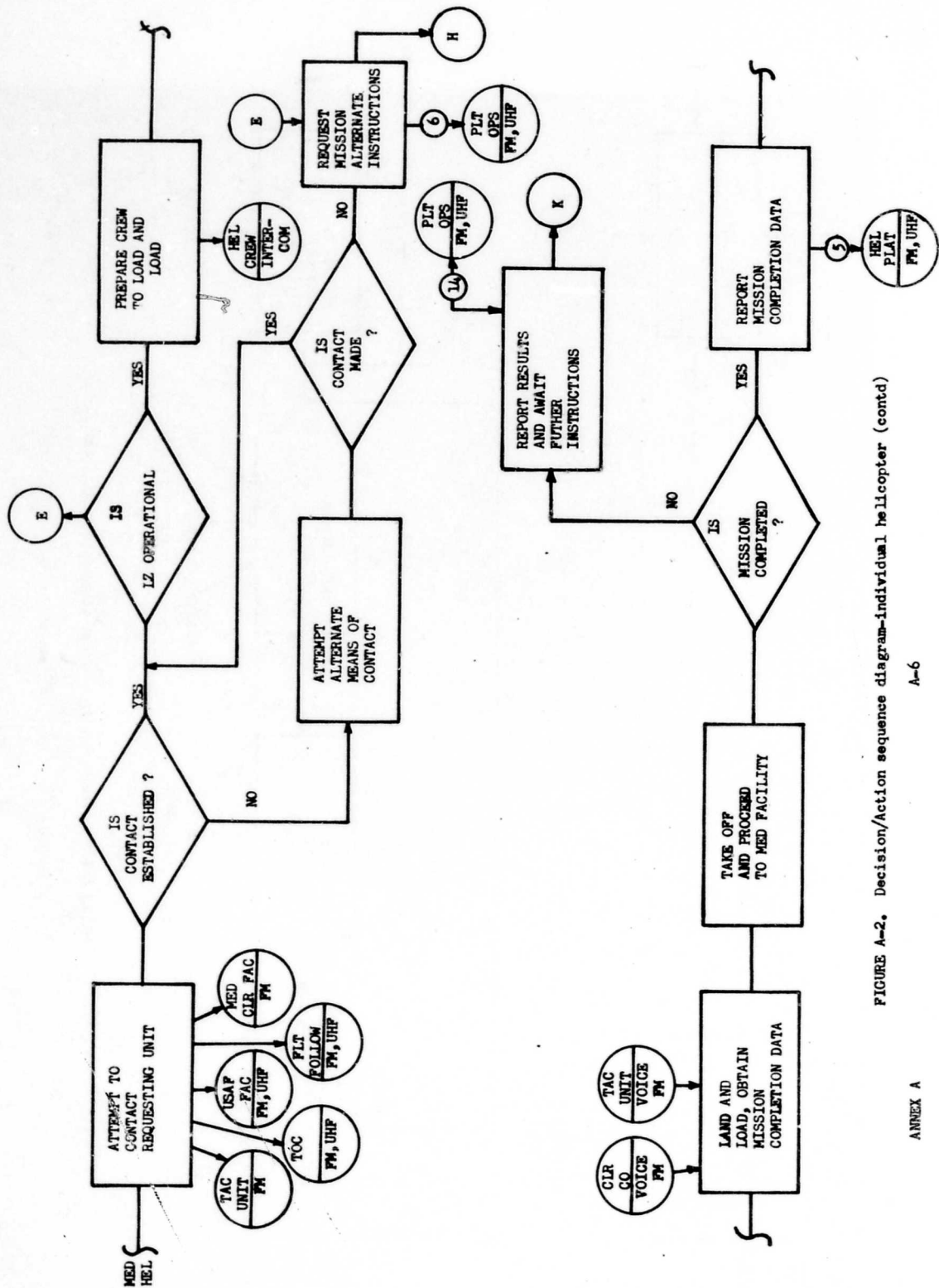

FIGURE A-2. Decision/Action sequence diagram-individual helicopter (contd)

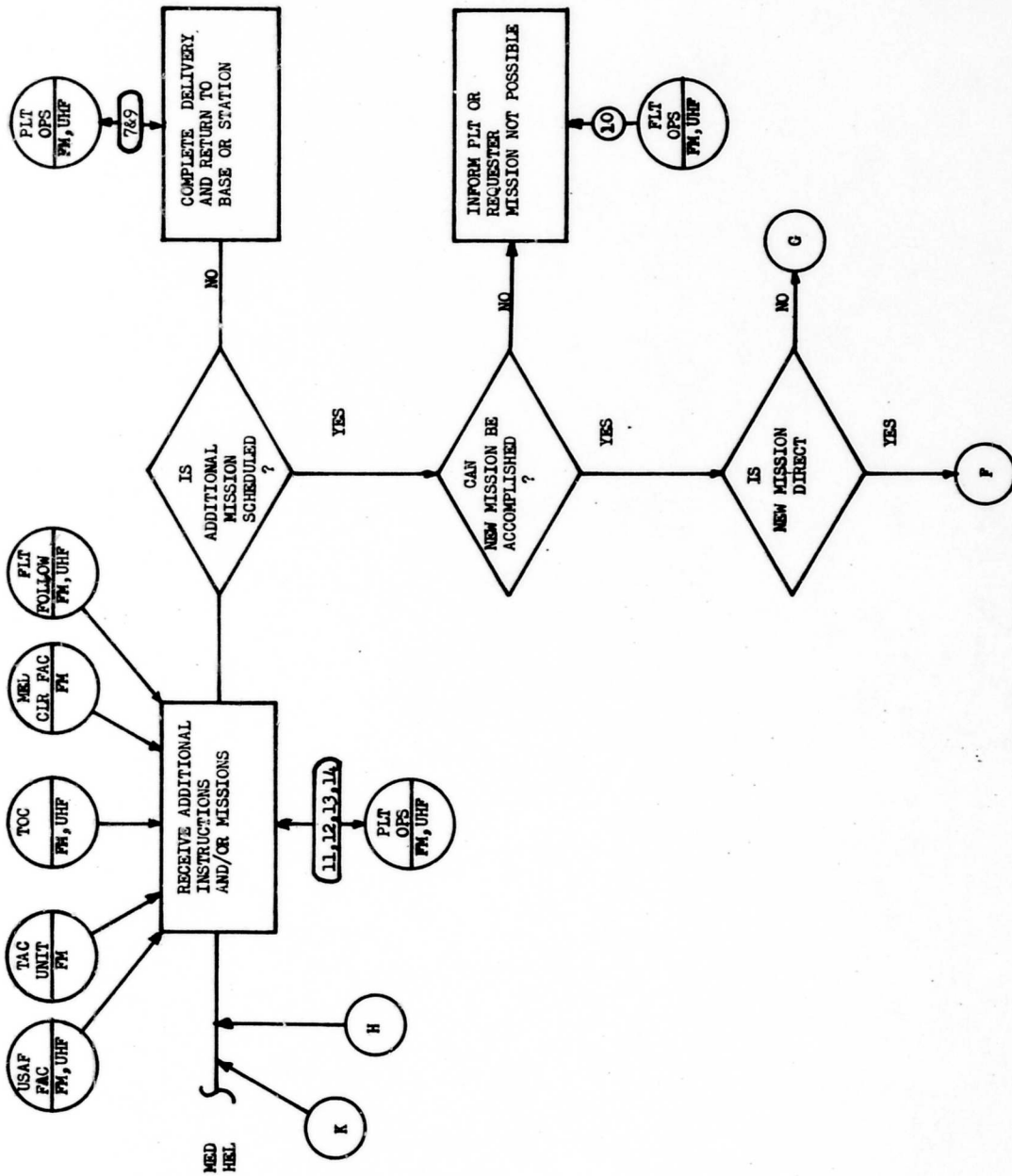

FIGURE A-2. Decision/Action sequence diagram-individual helicopter (contd)  
A-7

**THIS PAGE NOT USED**

## ANNEX B

### HELICOPTER INTERNAL PERSONNEL HOIST OPERATIONS

1. The purpose of this annex is to discuss hoist operations for the 498th Medical Company (Air Ambulance).

2. During the data collection period, the 498th Medical Company (Air Ambulance) used the UH-1D helicopter internally mounted hoist to extract 50 patients from areas where landings were not possible. Hoist operations were most frequent in jungle areas of the central plateau near Pleiku and Ban Me Thuot, and in the Annamite mountains west of Tuy Hoa and west and southwest of Nha Trang. These jungle areas consisted of two canopies of heavy foliage with the first canopy about 40 feet and the second about 125 feet above the jungle floor. Some canopies extended higher than 200 feet. The terrain elevation ranged from 2,000 feet above sea level (ASL). During the evaluation, extreme maximum temperature for these areas was 95 degrees Fahrenheit, the mean maximum temperature was 87 degrees Fahrenheit. (See figure B-1) Representative operating weight of a UH-1D Dust Off helicopter, carrying a full fuel load, medical equipment, and personnel hoist was 8,190 pounds. (See figure B-2)

3. All hoist operations required the helicopter to be hovered out-of-ground-effect (OGE) for prolonged periods of time. The OGE hovering capability of the UH-1D helicopter is determined by the power available at a given temperature and pressure/altitude, and is based on a no-wind condition. For prolonged hovering OGE, it is necessary to use the power chart (figure B-3) to determine gross weight at which a UH-1D can hover OGE at a specific altitude and given outside air temperature. For example, to hover OGE at an altitude of 6,000 feet above sea level (ASL) with an outside air temperature of (OAT) of 15 degrees centigrade, maximum gross weight of the helicopter should not exceed 7,030 pounds. If the OAT were 35 degrees centigrade (95 degrees Fahrenheit), the same helicopter would be limited to an altitude of 2,000 ASL to hover OGE.

4. Most of the Dust Off hoist operations were conducted at altitudes between 2,000 feet and 5,000 feet ASL and OAT between 80 degrees and 95 degrees Fahrenheit. The maximum allowable gross weight to hover OGE at 2,000 feet ASL will vary from 7,400 to 7,000 pounds as the temperature varies from 80 degrees to 95 degrees Fahrenheit. The maximum allowable gross weight to hover OGE at 5,000 feet ASL will vary from 6,600 to 6,200 pounds as the temperature varies from 80 degrees to 95 degrees Fahrenheit.

5. In the central plateau region of Pleiku, where 30 percent of the Dust Off hoist operations were conducted, the average ground elevation was generally 3,000 feet ASL and mean OAT 87 degrees Fahrenheit. The maximum gross weight for these hoist pick-ups was 7,030 pounds. As shown in figure

| STATION         | JAN | FEB | MAR | APR | MAY | JUN | JUL | AUG | SEP | OCT | NOV | DEC | YEARS OF RECORD |
|-----------------|-----|-----|-----|-----|-----|-----|-----|-----|-----|-----|-----|-----|-----------------|
| BAN ME THOUT    |     |     |     |     |     |     |     |     |     |     |     |     |                 |
| Elev. 1,762 Ft. |     |     |     |     |     |     |     |     |     |     |     |     |                 |
| Extreme Maximum | 92  | 95  | 99  | 103 | 99  | 95  | 90  | 94  | 89  | 92  | 90  | 88  | 18              |
| Mean Maximum    | 80  | 85  | 89  | 90  | 88  | 85  | 84  | 84  | 83  | 82  | 81  | 79  | 18              |
| KONTUM          |     |     |     |     |     |     |     |     |     |     |     |     |                 |
| Elev. 1,759 Ft. |     |     |     |     |     |     |     |     |     |     |     |     |                 |
| Extreme Maximum | 96  | 101 | 101 | 103 | 103 | 94  | 94  | 93  | 94  | 95  | 91  | 95  | 23              |
| Mean Maximum    | 82  | 86  | 90  | 92  | 90  | 86  | 83  | 84  | 84  | 84  | 82  | 80  | 23              |
| NHA TRANG       |     |     |     |     |     |     |     |     |     |     |     |     |                 |
| Elev. 20 Ft.    |     |     |     |     |     |     |     |     |     |     |     |     |                 |
| Extreme Maximum | 89  | 92  | 94  | 97  | 101 | 103 | 102 | 103 | 101 | 95  | 94  | 91  | 47              |
| Mean Maximum    | 82  | 84  | 86  | 89  | 91  | 92  | 91  | 91  | 89  | 86  | 84  | 82  | 47              |
| PHAN RANG       |     |     |     |     |     |     |     |     |     |     |     |     |                 |
| Elev. 33 Ft.    |     |     |     |     |     |     |     |     |     |     |     |     |                 |
| Extreme Maximum | 92  | 95  | 101 | 99  | 101 | 101 | 97  | 98  | 100 | 91  | 92  | 88  | 1               |
| Mean Maximum    | 84  | 87  | 90  | 92  | 92  | 92  | 93  | 92  | 90  | 87  | 86  | 84  | 5               |
| PHAN THIET      |     |     |     |     |     |     |     |     |     |     |     |     |                 |
| Elev. 39 Ft.    |     |     |     |     |     |     |     |     |     |     |     |     |                 |
| Extreme Maximum | 94  | 93  | 96  | 96  | 98  | 100 | 95  | 97  | 97  | 94  | 93  | 94  | 10              |
| Mean Maximum    | 85  | 85  | 87  | 89  | 90  | 90  | 89  | 90  | 89  | 87  | 87  | 86  | 10              |
| PLEIKU          |     |     |     |     |     |     |     |     |     |     |     |     |                 |
| Elev. 2,533 Ft. |     |     |     |     |     |     |     |     |     |     |     |     |                 |
| Extreme Maximum | 91  | 95  | 96  | 97  | 96  | 90  | 91  | 88  | 90  | 90  | 87  | 88  | 12              |
| Mean Maximum    | 81  | 84  | 87  | 88  | 85  | 81  | 78  | 80  | 80  | 81  | 80  | 79  | 12              |
| QUI NHON        |     |     |     |     |     |     |     |     |     |     |     |     |                 |
| Elev. 36 Ft.    |     |     |     |     |     |     |     |     |     |     |     |     |                 |
| Extreme Maximum | 91  | 96  | 101 | 97  | 103 | 106 | 108 | 106 | 102 | 99  | 91  | 87  | 32              |
| Mean Maximum    | 78  | 80  | 83  | 87  | 90  | 92  | 92  | 94  | 89  | 84  | 81  | 78  | 32              |
| TUY HOA         |     |     |     |     |     |     |     |     |     |     |     |     |                 |
| Elev. 33 Ft.    |     |     |     |     |     |     |     |     |     |     |     |     |                 |
| Extreme Maximum | 91  | 97  | 97  | 101 | 102 | 102 | 99  | 100 | 100 | 94  | 90  | 85  | 13              |
| Mean Maximum    | 79  | 81  | 85  | 89  | 92  | 93  | 93  | 92  | 90  | 85  | 82  | 80  | 13              |
| BAO LOC         |     |     |     |     |     |     |     |     |     |     |     |     |                 |
| Elev. 2,789 Ft. |     |     |     |     |     |     |     |     |     |     |     |     |                 |
| Extreme Maximum | 86  | 89  | 89  | 90  | 89  | 86  | 85  | 86  | 86  | 86  | 84  | 85  | 14              |
| Mean Maximum    | 79  | 82  | 84  | 84  | 82  | 79  | 78  | 78  | 78  | 79  | 78  | 78  | 14              |

FIGURE B-1. Extreme maximum and mean maximum temperatures, II CTZ

| EQUIPMENT                       | WEIGHT            |
|---------------------------------|-------------------|
| Basic Weight (UH-1D)            | 5,323 lbs.        |
| Oil                             | 34 lbs.           |
| Fuel                            | 1,400 lbs.        |
| Crew (5 <sup>w</sup> 200 lbs)   | 1,000 lbs.        |
| Individual Armor Protection     | 80 lbs.           |
| Hot Climate Survival Kit, Land  | 25 lbs.           |
| Hot Climate Survival Kit, Water | 12 lbs.           |
| Life Vests (14)                 | 28 lbs.           |
| Litters (3)                     | 36 lbs.           |
| Medical Supplies                | 35 lbs.           |
| Individual Weapons              | 46 lbs.           |
| Mechanic's Tools                | 20 lbs.           |
| Hoist                           | 151 lbs.          |
| <b>Total</b>                    | <b>8,190 lbs.</b> |

FIGURE B-2 UH-1D helicopter operating weight

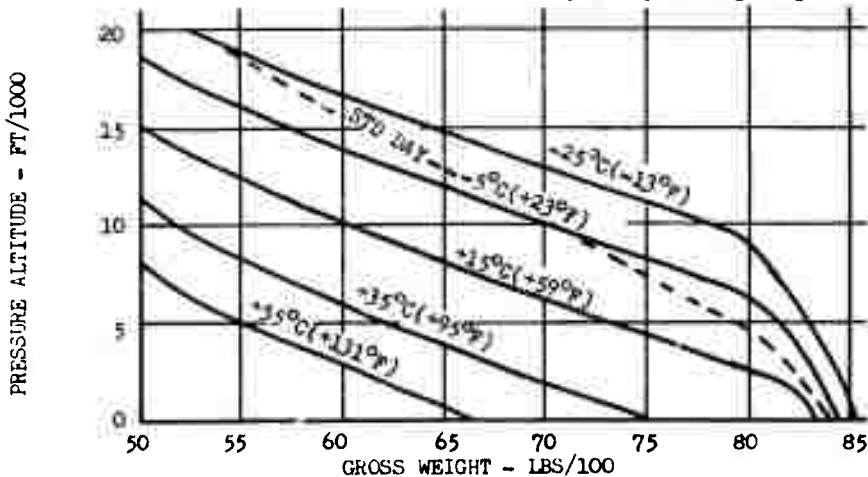

FIGURE B-3 Maximum gross weight for hovering out-of-ground effect with normal rated power.

B-2, the normal operating weight of the Dust Off helicopter was 8,190 pounds. In order to accomplish a hoist mission under these conditions it would be necessary to reduce the operating weight of the helicopter by 1,160 pounds. The duration of hoist missions during the evaluation period averaged 1 hour and 5 minutes. Assuming a rate of fuel consumption of 700 pounds per hour, the amount of fuel required for completion of an average mission with a 30-minute fuel reserve is 1,100 pounds. By not filling the fuel tank to capacity, a savings of 300 pounds in the operating weight of the Dust Off helicopters is realized. A further weight reduction of 860 pounds is required for the helicopter to be able to hover OGE. If the crew chief and patient protector with their weapons and armor protection are removed the weight can be reduced by 400 pounds. Approximately 350 pounds of fuel will be used flying to the pick-up site. This will bring the weight of the helicopter within allowable limits of the maximum gross weight to hover OGE for completion of this mission.

6. The UH-1D Helicopter was extended to its limits and often beyond for the completion of an "average" Dust Off hoist mission. The helicopters were constantly operated at maximum gross weight and, during hoisting of the patient, often exceeded gross weight limitations. This restricted the helicopter to one hoist pick-up per sortie. Many hoist missions required several sorties to be completed. On one occasion during the evaluation, a Dust Off helicopter operating from a field site made 14 sorties and evacuated 14 patients to complete a single hoist mission.

7. The critical gross weight conditions became more severe with the increase of temperature or altitude at which hovering OGE was required. On 10 occasions temperature and pressure/altitude at the pick-up site were such that the Dust Off helicopters had insufficient power available to accomplish the hoist mission. On these occasions, assistance was requested and received from a medium helicopter company equipped with CH-47 Chinook helicopters.

8. Enemy ground fire received during hoisting of patients greatly increased hazards of hoist operations. The reduction in crew to decrease the helicopters' operating weight left the aircraft without armed protection yet exposed to enemy fire for the time that was required to hoist the patient into the helicopter. During the 8-week data collection period, five Dust Off helicopters were severely damaged by enemy fire while hovering for a hoist pick-up. One of these helicopters was totally destroyed when hit by an enemy rocket or mortar round. The pilot and crew members were killed and the co-pilot was critically injured. A second of these helicopters took enemy fire in the area of the flight controls. Inspection of the aircraft after a 20 minute flight to home base revealed that one of the nine rounds received (.30 caliber or larger) had penetrated the main rotor mast. The most enemy fire received by one Dust Off helicopter while hovering for a hoist pick-up was 19 rounds. One of these rounds passed completely through the pilot's ballistic helmet, which he was wearing. This aircraft was severely damaged but all the crew escaped injury.

9. Dust Off hoist operations were equally critical in all areas of operation. The terrain and climatic conditions greatly reduced the hover OGE capability of the helicopter. Aircraft were constantly extended to their maximum allowable operating limits and often beyond to accomplish the missions. Hoist missions usually required hovering for long periods of time and constant exposure to enemy fire. In the final analysis the success of Dust Off hoist missions can be attributed to the willingness, determination, team work, and flying skills of the Dust Off crews.

10. At the close of the evaluation, the 498th Medical Company (Air Ambulance) began to receive the newer UH-1H helicopters. This helicopter is equipped with the T53-L-13 engine, which is rated at 1400 shaft horsepower (SHP) as opposed to 1100 SHP in the T53-L-11 engine in the UH-1D. The performance of the UH-1H is expected to correct many of the shortcomings of the UH-1D in hoist operations in RVN.

THIS PAGE NOT USED

ANNEX C

EVACUATION MISSIONS

1. The purpose of this annex is to show the flying hours logged, number of casualties evacuated, to include KHA, sorties flown, missions accomplished, and other support provided by the 498th Medical Company (Air Ambulance) during the period 13 February - 9 April, 1967.

2. FLYING HOURS LOGGED BY TYPE OF MISSION

| UNIT ELEMENT          | HQ & 1st |       | 2nd |       | 3rd & 4th |       | TOTAL |       |
|-----------------------|----------|-------|-----|-------|-----------|-------|-------|-------|
|                       | Day      | Night | Day | Night | Day       | Night | Day   | Night |
| 1. Medical Evacuation | 469      | 142   | 541 | 135   | 708       | 254   | 1718  | 531   |
| 2. Combat Assault Spt | 61       | 3     | 24  |       | 21        |       | 106   | 3     |
| 3. Defoliation Spt    | 2        |       |     |       |           |       | 2     |       |
| 4. Blood              | 4        | 1     |     |       | 4         | 1     | 8     | 2     |
| 5. Medical Resupply   | 15       | 2     | 8   |       | 7         | 6     | 30    | 8     |
| 6. V. I. P.           | 18       |       | 1   |       | 13        |       | 32    |       |
| 7. Administrative     | 88       | 3     | 54  | 5     | 67        | 5     | 209   | 13    |
| 8. Maintenance        | 42       |       | 11  |       | 34        |       | 87    |       |
| 9. Training           | 27       | 10    | 3   |       | 11        | 2     | 41    | 12    |
| 10. Search & Rescue   |          |       |     |       | 2         | 2     | 2     | 2     |
| 11.                   |          |       |     |       |           |       |       |       |
| 12. Totals            | 726      | 161   | 642 | 140   | 867       | 270   | 2235  | 571   |

3. CASUALTIES EVACUATED BY NATIONALITY TO INCLUDE KILLED IN HOSTILE ACTION

| UNIT ELEMENT                | HQ & 1st |       | 2nd   |       | 3rd & 4th |       | TOTAL |       |
|-----------------------------|----------|-------|-------|-------|-----------|-------|-------|-------|
|                             | Day      | Night | Day   | Night | Day       | Night | Day   | Night |
| 1. United States            | 707      | 165   | 1,565 | 240   | 866       | 277   | 3,138 | 682   |
| 2. PWMAF                    | 110      | 26    | 69    | 1     | 242       | 81    | 421   | 108   |
| 3. ARVN                     | 109      | 78    | 305   | 70    | 621       | 191   | 1,035 | 339   |
| 4. Vietnam Civilian         | 52       | 2     | 9     | 3     | 440       | 128   | 501   | 133   |
| 5. Viet Cong                | 10       | 3     | 5     |       | 48        | 16    | 63    | 19    |
| 6. Other                    | 12       |       | 1     |       | 3         | 2     | 16    | 2     |
| 7. Killed by Hostile Action | 12       | 4     | 13    |       | 23        | 10    | 48    | 14    |
| 8. Total                    | 1,012    | 278   | 1,967 | 314   | 2,243     | 705   | 5,222 | 1,297 |
| 9.                          |          |       |       |       |           |       |       |       |
| 10.                         |          |       |       |       |           |       |       |       |
| 11.                         |          |       |       |       |           |       |       |       |

4. SORTIES FLOWN BY TYPE OF MISSIONS

| UNIT ELEMENT          | HQ & 1st |       | 2nd   |       | 3rd & 4th |       | TOTAL |       |
|-----------------------|----------|-------|-------|-------|-----------|-------|-------|-------|
|                       | Day      | Night | Day   | Night | Day       | Night | Day   | Night |
| 1. Medical Evacuation | 1,046    | 291   | 1,683 | 376   | 2,257     | 725   | 4,986 | 1,392 |
| 2. Combat Assault Cov | 88       | 2     | 30    |       | 37        |       | 155   | 2     |
| 3. Defoliation Spt    | 2        |       |       |       |           |       | 2     |       |
| 4. Blood              | 6        | 3     | 2     |       | 7         | 5     | 15    | 8     |
| 5. Medical Resupply   | 18       | 2     | 11    |       | 22        | 2     | 51    | 4     |
| 6. V. I. P.           | 35       |       |       |       | 1         | 2     | 36    | 2     |
| 7. Administrative     | 164      | 2     | 106   | 6     | 143       | 15    | 413   | 23    |
| 8. Maintenance        | 143      |       | 31    |       | 122       | 1     | 296   | 1     |
| 9. Training           | 63       | 18    | 6     |       | 33        | 4     | 102   | 22    |
| 10. Search & Rescue   | 4        |       |       |       | 9         | 9     | 13    | 9     |
| 11. Total             | 1,569    | 318   | 1,869 | 382   | 2,631     | 767   | 6,069 | 1,463 |

5. MISSIONS ACCOMPLISHED BY TYPE OF MISSIONS

| UNIT ELEMENT          | HQ & 1st |       | 2nd |       | 3rd & 4th |       | TOTAL |       |
|-----------------------|----------|-------|-----|-------|-----------|-------|-------|-------|
|                       | Day      | Night | Day | Night | Day       | Night | Day   | Night |
| 1. Medical Evacuation | 457      | 129   | 513 | 106   | 841       | 297   | 1,811 | 532   |
| 2. Combat Assault Spt | 53       | 2     | 14  |       | 14        |       | 81    | 2     |
| 3. Defoliation Spt    | 1        |       |     |       |           |       | 1     |       |
| 4. Blood              | 4        | 1     |     |       | 4         | 1     | 8     | 2     |
| 5. Medical Resupply   | 11       | 1     | 5   |       | 9         | 3     | 25    | 4     |
| 6. V. I. P.           | 17       |       |     |       | 7         | 1     | 24    | 1     |
| 7. Administrative     | 81       | 4     | 51  | 3     | 91        | 10    | 223   | 17    |
| 8. Maintenance        | 68       | 1     | 16  |       | 62        | 1     | 146   | 2     |
| 9. Training           | 24       | 5     | 6   |       | 14        | 1     | 44    | 6     |
| 10. Search & Rescue   | 2        |       |     |       | 4         | 2     | 6     | 2     |
| 11. Total             | 718      | 143   | 605 | 109   | 1,046     | 316   | 2,369 | 568   |

6. OTHER SUPPORT PROVIDED

| UNIT ELEMENT        | HQ & 1st |       | 2nd   |       | 3rd & 4th |       | TOTAL  |       |
|---------------------|----------|-------|-------|-------|-----------|-------|--------|-------|
|                     | Day      | Night | Day   | Night | Day       | Night | Day    | Night |
| 1. Passengers Flown | 752      | 25    | 335   | 22    | 563       | 84    | 1,650  | 131   |
| 2. Hoist Operation  | 23       | 9     | 11    | 1     | 1         |       | 35     | 10    |
| 3. Medical Supplies | 8,700    |       | 9,859 |       | 6,400     |       | 24,959 |       |
| 4. Units of Blood   | 273      |       | 791   |       | 227       |       | 1,291  |       |
| 5.                  |          |       |       |       |           |       |        |       |
| 6.                  |          |       |       |       |           |       |        |       |
| 7.                  |          |       |       |       |           |       |        |       |
| 8.                  |          |       |       |       |           |       |        |       |
| 9.                  |          |       |       |       |           |       |        |       |
| 10.                 |          |       |       |       |           |       |        |       |
| 11.                 |          |       |       |       |           |       |        |       |
| 12.                 |          |       |       |       |           |       |        |       |

THIS PAGE NOT USED

## ANNEX D

### ADDITIONAL DUTIES - HELICOPTER PLATOONS

1. The purpose of this annex is to describe the added duties of each helicopter platoon and relate the impact of these duties on platoon activities.

#### 2. CLERICAL AND ADMINISTRATIVE TASKS

Clerical and administrative tasks consisted of preparing and typing reports, correspondence, and files. The 2d Platoon and consolidated 3d and 4th Platoons submitted reports and routine correspondence not required from the 1st platoon which was located with company headquarters. Examples of this work load included daily feeder morning reports to company headquarters and strength reports submitted to the supporting units at the separate platoon locations for mess, quarters, and medical dispensary facilities. Other correspondence submitted to the company from the 2d, 3d, and 4th platoons were requests for R&R leave, malaria control, requisition for forms, and recommendations for awards and decorations. Location of the 1st platoon with company headquarters permitted many of these reports to be oral. Other duties in this area common to all platoons were duty rosters, logs, and maintenance of a minimum number of files.

| <u>PLATOON</u> | <u>DAILY MAN-HOURS</u> |
|----------------|------------------------|
| 1st            | 3.3                    |
| 2nd            | 12.1                   |
| 3d/4th         | 14.6                   |

#### 3. AIRCRAFT MAINTENANCE TASKS

The 2nd and 3rd/4th helicopter platoons were required to maintain their own technical supply. This included requisition of aircraft parts, maintenance of a document register, and the prescribed load list. The 1st platoon was required to provide only normal organizational maintenance.

| <u>PLATOON</u> | <u>DAILY MAN-HOURS</u> |
|----------------|------------------------|
| 1st            | 10.6                   |
| 2nd            | 18.4                   |
| 3rd/4th        | 13.6                   |

#### 4. VEHICLE MAINTENANCE TASKS

The 1st platoon was supported by the company motor pool and was required only to perform driver maintenance. The 2nd platoon received support from the 52nd Aviation Battalion and performed more maintenance work than the 1st platoon because of the assignment of an additional vehicle.

The 3rd and 4th platoons were required to establish and operate a motor pool. The company motor sergeant operated this motor pool and was assisted by aircraft mechanics as an additional duty. Two Vietnamese civilians were also employed in the motor pool.

| <u>PLATOON</u> | <u>DAILY MAN-HOURS</u> |
|----------------|------------------------|
| 1st            | 2.3                    |
| 2nd            | 4.7                    |
| 3rd/4th        | 13.6                   |

#### 5. OTHER MAINTENANCE TASKS

These duties included maintenance on equipment other than vehicles and aircraft such as weapons, radios, and organizational equipment.

| <u>PLATOON</u> | <u>DAILY MAN-HOURS</u> |
|----------------|------------------------|
| 1st            | 3.5                    |
| 2nd            | 4.2                    |
| 3rd/4th        | 8.0                    |

#### 6. SECURITY TASKS

Patient protector duties accounted for the majority of the duty tasks. Personnel assigned to company headquarters provided the patient protectors for the 1st platoon. The 2nd, 3rd, and 4th platoons used personnel from within platoon resources as an additional duty. In addition to the patient protector duties the 2nd, 3rd, and 4th platoons were required to perform limited area guard duties.

| <u>PLATOON</u> | <u>DAILY MAN-HOURS</u> |
|----------------|------------------------|
| 1st            | 0.0                    |
| 2nd            | 38.2                   |
| 3rd/4th        | 11.5                   |

#### 7. UNIT AREA IMPROVEMENT TASKS

This area consisted of construction of platoon offices, living quarters, day rooms, and general repair and maintenance of physical facilities.

| <u>PLATOON</u> | <u>DAILY MAN-HOURS</u> |
|----------------|------------------------|
| 1st            | 3.8                    |
| 2nd            | 7.0                    |
| 3rd/4th        | 31.9                   |

## 8. SUPPLY TASKS

The 1st platoon did not maintain a supply section due to its location with Company Headquarters and support from company supply activities. The 2nd and consolidated 3rd and 4th platoons maintained their own supply activities as additional duties. These platoons requisitioned supplies, maintained a document register, and utilized and accounted for self-service supplies at their respective locations. Other tasks included issue, storage, cleaning, and maintenance of general platoon equipment.

| <u>PLATOON</u> | <u>DAILY MAN-HOURS</u> |
|----------------|------------------------|
| 1st            | 0.0                    |
| 2nd            | 4.0                    |
| 3rd/4th        | 11.7                   |

## 9. OPERATIONS TASKS

Platoon deployment necessitated that all platoons maintain their own operations activities. These functions were operated on a 24-hour basis and required additional personnel from within platoon resources, including operations specialists, radio operators, and an operations officer. These tasks were numerous and included the following: daily operations status reports, duty rosters for aircraft commander and pilot, crew chief, aidmen, and patient protectors.

| <u>PLATOON</u> | <u>DAILY MAN-HOURS</u> |
|----------------|------------------------|
| 1st            | 32.0                   |
| 2nd            | 34.0                   |
| 3rd/4th        | 36.0                   |

THIS PAGE NOT USED

## ANNEX E

### GROUND CONTROL APPROACH RADAR

1. The purpose of this annex is to present the rationale for deleting the Ground Control Approach (GCA) Radar Set AN/TPN-8 and the Radio Beacon Set AN/GRN-6 from the TOE.
2. The 498th Medical Company (Air Ambulance) deployed to RVN with the Ground Control Approach Radar Set AN/TPN-8 and the Radio Beacon Set AN/GRN-6 and the personnel needed to operate and maintain the equipment. Since the airfields from which they operated were either instrumented or, as in the case at Qui Nhon, programmed for instrumentation and since this equipment was critical and in short supply, it was transferred to the 125th Air Traffic Control Company.
3. The radar and beacon sets were included in the TOE to provide the company with a capability for operating an instrumented airfield or heliport near a major hospital. This was done to insure accomplishment of the mission in the event that the hospital was not located near an existing instrumented airfield. Also, there was no alternative to including this equipment in the TOE as there were no sources available that could provide the company with this capability on an as-required basis.
4. In a recent realignment of responsibilities the 125th Air Traffic Control Company was charged with operating the Army's flight following service and with providing mobile GCA teams to users on an as required basis. Therefore, any need that the 498th Medical Company (Air Ambulance) may later develop for an instrumented airfield can be satisfied by these mobile GCA teams.
5. If the TOE of the Army-wide Air Traffic Control company is changed to parallel the organization of the 125th Air Traffic Control Company, USACDC should consider deleting the Air Traffic Control Section from the TOE of the Medical Company (Air Ambulance) at the next scheduled revision.

**THIS PAGE NOT USED**

ANNEX F

PERSONNEL MODIFICATIONS TO TOE 8-137G

1. The purpose of this annex is to provide a ready reference and comparison of the proposed modifications to the personnel authorizations of TOE 8-137G.

2. PARA 01 COMPANY HEADQUARTERS

|                          | TOE 8-137G<br>Grade | TOE 8-137<br>(Proposed)<br>Grade | TOE 8-137G<br>No. | TOE 8-137<br>(Proposed)<br>No. |
|--------------------------|---------------------|----------------------------------|-------------------|--------------------------------|
| 01 Company Commander     | MAJ                 | MAJ                              | 1                 | 1                              |
| 02 Executive Officer     | O                   | CPT                              | 0                 | 1                              |
| 03 Supply Officer        | O                   | LT                               | 0                 | 1                              |
| 04 First Sergeant (NC)   | E-8                 | E-8                              | 1                 | 1                              |
| 05 Mess Steward (NC)     | E-6                 | E-7                              | 1                 | 1                              |
| 06 Supply Sergeant (NC)  | E-6                 | E-7                              | 1                 | 1                              |
| 07 Helicopter Crew Chief | E-5                 | E-5                              | 1                 | 1                              |
| 08 Company Clerk         | E-4                 | E-5                              | 1                 | 1                              |
| 09 First Cook            | E-5                 | E-5                              | 3                 | 3                              |
| 10 Clerk Typist          | O                   | E-4                              | 0                 | 3                              |
| 11 Supply Clerk          | O                   | E-4                              | 0                 | 2                              |
| 12 Armorer               | E-4                 | E-4                              | 1                 | 1                              |
| 13 Cook                  | E-4                 | E-4                              | 2                 | 2                              |
| 14 Cooks Helper          | E-3                 | E-3                              | 1                 | 1                              |
| 15 Lt Truck Driver       | E-3                 | E-3                              | 1                 | 1                              |
|                          |                     |                                  | <u>14</u>         | <u>21</u>                      |

3. PARA 02 FLIGHT OPERATIONS PLATOON

| Line                                   |  | TOE 8-137G | TOE 8-137<br>(Proposed) | TOE 8-137G | TOE 8-137<br>(Proposed) |
|--|--|------------|-------------------------|------------|-------------------------|
| 01 Flight Operations Officer           |  | CPT        | CPT                     | 1          | 1                       |
| 02 Flight Operations Chief (NC)        |  | E-7        | E-7                     | 1          | 1                       |
| 03 Communications Chief (NC)           |  | E-5        | E-6                     | 1          | 1                       |
| 04 Senior Flight Operations Specialist |  | E-5        | E-5                     | 1          | 1                       |
| 05 Flight Operations Clerk             |  | E-4        | E-4                     | 1          | 2                       |
| 06 Flight Operations Specialist        |  | E-4        | E-4                     | 1          | 2                       |
| 07 Radio Teletype Operator             |  | E-4        | E-4                     | 2          | 2                       |
| 08 Teletype Operator                   |  | E-4        | E-4                     | 1          | 2                       |
| 09 Flight Operations Helper            |  | E-3        | E-3                     | 1          | 1                       |
| 10 Wireman                             |  | E-3        | E-3                     | 1          | 2                       |
|  |  |            |                         | <u>11</u>  | <u>15</u>               |

|  |            |                         |            |                         |
|--|------------|-------------------------|------------|-------------------------|
| 4. PARA 03 SERVICE PLATOON HEADQUARTERS          |            |                         |            |                         |
| Line   | TOE 8-137G | TOE 8-137<br>(Proposed) | TOE 8-137G | TOE 8-137<br>(Proposed) |
| 01 Platoon Leader                                | CPT        | CPT                     | 1          | 1                       |
| 02 Platoon Sergeant (NC)                         | E-7        | E-7                     | 1          | 1                       |
| 03 Technical Inspector                           | E-6        | E-6                     | 2          | 3                       |
| 04 Maintenance Data Specialist                   | E-4        | E-4                     | 2          | 2                       |
| 05 Power Generator Specialist                    | E-4        | E-4                     | 1          | 2                       |
| 06 Avionics Mechanic                             | E-4        | E-4                     | 4          | 4                       |
| 07 Repair Parts Specialist                       | E-4        | E-4                     | <u>2</u>   | <u>2</u>                |
|  |            |                         | 13         | 15                      |
| 5. PARA 04 AIRFIELD SERVICE SECTION              |            |                         |            |                         |
| 01 Section Sergeant (NC)                         | E-5        | E-5                     | 1          | 1                       |
| 02 Aircraft Fueling Specialist                   | E-4        | E-4                     | 5          | 5                       |
| 03 Crash Rescue Specialist                       | E-4        | E-4                     | 4          | 4                       |
| 04 Airfield Service Crewman                      | E-4        | E-4                     | <u>4</u>   | <u>4</u>                |
|  |            |                         | 14         | 14                      |
| 6. PARA 05 AIRCRAFT MAINTENANCE SECTION          |            |                         |            |                         |
| 01 Aircraft Maintenance Technician<br>(MOS 6716) | 0          | WO                      | 0          | 1                       |
| 02 Section Sergeant (NC)                         | 0          | E-6                     | 0          | 1                       |
| 03 Senior Helicopter Mechanic                    | E-5        | E-5                     | 12         | 12                      |
| 04 Helicopter Mechanic                           | E-4        | E-4                     | 17         | 18                      |
| 05 Helicopter Mechanic Helper                    | E-3        | E-3                     | <u>4</u>   | <u>6</u>                |
|  |            |                         | 33         | 38                      |
| 7. PARA 06 MOTOR MAINTENANCE SECTION             |            |                         |            |                         |
| 01 Motor Sergeant (NC)                           | E-5        | E-6                     | 1          | 1                       |
| 02 Wheel Vehicle Mechanic                        | E-4        | E-4                     | 3          | 4                       |
| 03 Wheel Vehicle Mechanic Helper                 | E-3        | E-3                     | <u>1</u>   | <u>1</u>                |
|  |            |                         | 5          | 6                       |
| 8. PARA 07 FOUR HELICOPTER PLATOONS              |            |                         |            |                         |
| 01 Platoon Leader                                | CPT        | CPT MS                  | 4          | 4                       |
| 02 Section Leader                                | LT         | LT MS                   | 8          | 8                       |
| 03 Evacuation Pilot                              | WO         | WO                      | 36         | 36                      |
| 04 Platoon Sergeant (NC)                         | E-6        | E-6                     | 0          | 4                       |
| 05 Air Ambulance Aidmen                          | E-5        | E-5                     | 24         | 24                      |
| 06 Helicopter Crew Chief                         | E-5        | E-5                     | 24         | 24                      |
| 07 Radio Operator                                | E-3        | E-4                     | <u>4</u>   | <u>8</u>                |
|  |            |                         | 100        | 108                     |

9. RECAPITULATIVE OF ADDITIONS

a. PARA 01

|                     |          |
|---------------------|----------|
| XO                  | 1        |
| Supply Officer (WO) | 1        |
| Clerk Typist        | 3        |
| Supply Clerk        | <u>2</u> |
|                     | 7        |

b. PARA 02

|                              |          |
|------------------------------|----------|
| Flight Operations Clerk      | 1        |
| Flight Operations Specialist | 1        |
| Teletype Operator            | 1        |
| Wireman                      | <u>1</u> |
|                              | 4        |

c. PARA 03

|                            |          |
|----------------------------|----------|
| Technical Inspector        | 1        |
| Power Generator Specialist | <u>1</u> |
|                            | 2        |

d. PARA 05

|                                       |          |
|---------------------------------------|----------|
| Aircraft Maintenance Technician (WO)  | 1        |
| Aircraft Maintenance Section Sergeant | 1        |
| Helicopter Mechanic                   | 1        |
| Helicopter Mechanic Helper            | <u>2</u> |
|                                       | 5        |

e. PARA 06

|                        |          |
|------------------------|----------|
| Wheel Vehicle Mechanic | <u>1</u> |
|                        | 1        |

f. PARA 07

|                  |          |
|------------------|----------|
| Platoon Sergeant | 4        |
| Radio Operator   | <u>4</u> |
|                  | 8        |

10. RECAPITULATIVE OF DELETIONS

a. PARA 02

|                                      |     |          |
|--------------------------------------|-----|----------|
| Line 04 Team Chief                   | E-5 | 1        |
| 05 Senior Control Tower Operator     | E-5 | 1        |
| 07 Senior Landing Control Specialist | E-5 | 1        |
| 08 Control Tower Operator            | E-4 | 1        |
| 11 Landing Control Operator          | E-4 | 1        |
| 14 Control Tower Helper              | E-3 | <u>1</u> |
|                                      |     | 6        |

c. PARA 03

|         |                         |     |          |
|---------|-------------------------|-----|----------|
| Line 05 | GCA Equipment Repairman | E-5 | <u>1</u> |
|         |                         |     | 1        |

c. PARA 05

|         |                  |     |          |
|---------|------------------|-----|----------|
| Line 01 | Section Sergeant | E-6 | <u>3</u> |
|         |                  |     | 3        |

11. CHANGE OF GRADE

a. PARA 01

|                 |     |     |
|-----------------|-----|-----|
| Mess Stewqrd    | E-6 | E-7 |
| Supply Sergeant | E-6 | E-7 |
| Company Clerk   | E-4 | E-5 |

b. PARA 02

|                      |     |     |
|----------------------|-----|-----|
| Communications Chief | E-5 | E-6 |
|----------------------|-----|-----|

12. TOTAL AUTHORIZATION BY GRADE

a. Officers

|     |                  |           |
|-----|------------------|-----------|
| (1) | Major            | 1         |
| (2) | Captain          | 7         |
| (3) | Lieutenants      | 9         |
| (4) | Warrant Officers | <u>37</u> |
|     | Total            | 54        |

b. Non Commissioned Officers

|     |         |          |
|-----|---------|----------|
| (1) | NCO E-8 | 1        |
| (2) | NCO E-7 | 4        |
| (3) | NCO E-6 | 7        |
| (4) | NCO E-5 | <u>1</u> |
|     | Total   | 13       |

c. Enlisted

|     |       |           |
|-----|-------|-----------|
| (1) | E-6   | 3         |
| (2) | E-5   | 66        |
| (3) | E-4   | 69        |
| (4) | E-3   | <u>12</u> |
|     | Total | 150       |

## ANNEX G

### GLOSSARY

**AREA SUPPORT**-- A type of aeromedical evacuation support provided by the 498th Medical Company (Air Ambulance) and elements thereof, to US/FWMAF, ARVN and some local nationals within a specified area or zone. The support provided is based on patient priorities rather than priority to a specific unit or units.

**ARVN**-- Army of the Republic of Vietnam.

#### CATEGORIES OF PATIENTS FOR AIR EVACUATION:

**URGENT**-- A patient who is classified as an emergency case. Evacuation of the patient is required within 12 hours to save life or limb.

**PRIORITY**-- Patients for whom evacuation is required within 24 hours.

**ROUTINE**-- Patients for whom evacuation is required within 72 hours.

**CIVILIAN IRREGULAR DEFENSE GROUP (CIDG)**-- A paramilitary force locally recruited, clothed, fed, armed, trained, and led by ARVN Special Forces personnel and advised by US Special Forces personnel.

**CORPS TACTICAL ZONE (CTZ)**-- A major Vietnamese military and political subdivision of the Republic of Vietnam (RVN). There are four CTZ covering the entire area of South Vietnam. The corps commander is the permanent Government of Vietnam (GVN) representative in his CTZ.

**DUST OFF**-- Radio call sign used by all nondivisional medical evacuation helicopters in RVN. The call sign was originally assigned to the 57th Medical Detachment (Helicopter Ambulance) in 1963. It soon became synonymous with medical evacuation helicopter operations and has been used for this purpose ever since.

**FFORCEV**-- Field Force Vietnam. The I and II FFORCEV are both approximately corps size, I FFORCEV operates in the II Corps Tactical Zone (CTZ) and II FFORCEV operates in the III CTZ. I FFV or II FFV is also used.

**FREE WORLD MILITARY ASSISTANCE FORCE (FWMAF)**-- Those forces in RVN other than the Republic of Vietnam Armed Forces (RVNAF). They include military assistance from Thailand, Australia, Republic of China, New Zealand, Philippines, Republic of Korea, Spain, and United States. The term is frequently used by US forces to indicate forces other than US forces and RVNAF.

**HOVER-OUT-OF-GROUND EFFECT**-- A stationary flight position at a height above the ground (approximately one rotor diameter or greater) where the ground no longer influences the engine power required to hover. The power required is significantly higher than if the helicopter were hovering at a lower altitude in ground effect.

**MEDICAL REGULATING**-- The coordination and control of the movement of patients to the medical facilities best able to provide required medical care.

**MEDICAL REGULATION OFFICER (MRO)**-- An officer or NCO charged with the responsibility of medical regulating. An MRO is located at a medical group and higher headquarters.

**MINI-PORT**-- A heliport specifically designed for refueling. Several helicopters can be refueled simultaneously without stopping the engines of the aircraft.

**PATIENT PROTECTOR**-- A member of the Dust Off crew, armed with an M-14 or M-16 rifle, who provides protection for the patients during landing, loading, and takeoff.

**PERIODIC INSPECTION (PE)**-- An inspection required on Army Aircraft after each 100 hours of flight or sooner at the discretion of the maintenance officer or unit commander. The inspection entails organizational maintenance requirements and direct support maintenance requirements.

**SORTIE**-- One sortie is one aircraft making one landing for the purpose of loading or off-loading personnel, ordnance, or fuel; except that, specifically, armed helicopters escorting troop carrying helicopters in an airmobile assault operation will log a sortie in the landing zone regardless of whether or not they land.

## ANNEX H

### REFERENCES

1. Message, DA 793777 from ACSFOR to CINCUSARPAC, Evaluation Plan, Medical Company - Air Ambulance, (U) DTG 31044Z December 1966. Unclassified.
2. Letter, ACTIV-AAD, to HQ USACDC thru CINCUSARPAC, 24 October 1966, Evaluation Plan - Medical Company (Air Ambulance) TOE 8-137E (JRATA Project No. 1C-213.0) (U). Unclassified.
3. AR 320-5, Dictionary of United States Army Terms.
4. AR 350-5, Authorized Abbreviations and Brevity Codes.
5. FM 8-10, Medical Service. Theater of Operations.
6. FM 8-15, Division Medical Service, Infantry, Airborne, Mechanized, and Armored Divisions.
7. FM 8-16-1, (TEST) Medical Service, Field Army.
8. TOE 8-137G, Medical Air Ambulance Company.

THIS PAGE NOT USED

ANNEX I

DISTRIBUTION

Department of Defense

|   |    |
|---|----|
| Advanced Research Projects Agency, Office of the Secretary of Defense | 1  |
| Chief, ARPA R&D Field Unit, Vietnam                                   | 2  |
| Chief, ARPA R&D Field Unit, Thailand                                  | 1  |
| Defense Documentation Center  | 20 |

Joint Chiefs of Staff

|   |   |
|---|---|
| Office of the Special Assistant for Counterinsurgency and Special Activities, Organization of the Joint Chiefs of Staff | 1 |
|---|---|

Unified and Joint Commands, MAAGS, and Missions

|  |   |
|--|---|
| Commander-in-Chief, Pacific  | 5 |
| Commander-in-Chief, US Strike Command  | 1 |
| Commander, US Military Assistance Command Vietnam, ATTN: J-34                    | 2 |
| Commander, US Military Assistance Command Vietnam, ATTN: J-1, J-2, J-4, J-5, J-6 | 5 |
| Commander, US Military Assistance Command Thailand                               | 1 |
| Commander-in-Chief, US Southern Command  | 1 |

Embassy

|   |   |
|---|---|
| OAS, US Embassy, Saigon, ATTN: Mr. W.T. Field | 2 |
|---|---|

United States Army

|  |    |
|--|----|
| Asst Chief of Staff for Force Development, Department of the Army  | 10 |
| Office of the Asst Chief of Staff for Force Development, Department of the Army, ATTN: ACTIV Liaison Officer | 10 |
| Commanding General, US Army Materiel Command   | 45 |
| Office of the Surgeon General, Department of the Army  | 20 |
| Commanding General, US Continental Army Command  | 25 |
| Commandant, Armed Forces Staff College   | 1  |
| Commanding General, US Army Combat Developments Command, ATTN: CDCRE-T                                       | 70 |
| Commanding General, US Army Combat Developments Command/ Experimentation Command                             | 3  |
| Commanding Officer, US Army LWL  | 2  |
| Commanding General, US Army Test & Evaluation Command  | 2  |
| Commander-in-Chief, USARPAC  | 5  |
| Commanding Officer, US Army Aero Medical Research Unit   | 2  |

ANNEX I

|  |        |
|--|--------|
| Commanding General, USARV, ATTN: AVHGC       | 15     |
| Commanding General, 1st Inf Div              | 5      |
| Commanding General, 4th Inf Div              | 5      |
| Commanding General, 9th Inf Div              | 5      |
| Commanding General, 25th Inf Div             | 5      |
| Commanding General, 1st Cav Div (Airmobile)  | 5      |
| Commanding General, 1st Bde, 101st Abn Div   | 5      |
| Commanding General, 173d Abn Bde             | 5      |
| Commanding General, 1st Avn Bde              | 5      |
| Commanding General, 196th Lt Inf Bde         | 5      |
| Commanding General, 199th Lt Inf Bde         | 5      |
| Commanding Officer, 11th Armd Cav Regiment   | 5      |
| <br><u>United States Navy</u>                |        |
| Chief, NRDUV                                 | 2      |
| <br><u>United States Marine Corps</u>        |        |
| Commanding General, III MAF, ATTN: ACofS, G3 | 5      |
| <br>ACTIV Project Officer, ATTN: AAD         | <br>10 |
| ACTIV Library                                | 20     |

UNCLASSIFIED

Security Classification

DOCUMENT CONTROL DATA - R & D

(Security classification of title, body of abstract and indexing annotation must be entered when the overall report is classified)

|   |  |
|---|--|
| 1. ORIGINATING ACTIVITY (Corporate author)<br>Army Concept Team in Vietnam<br>APO San Francisco 96384 | 2a. REPORT SECURITY CLASSIFICATION<br>UNCLASSIFIED |
|   | 2b. GROUP  |

3. REPORT TITLE  
FIELD EVALUATION OF THE MEDICAL COMPANY (AIR AMBULANCE) TOE 8-137E

4. DESCRIPTIVE NOTES (Type of report and inclusive dates)  
FINAL REPORT - 13 Feb to 13 Apr 1967

5. AUTHOR(S) (First name, middle initial, last name)  
Eugene R. Lucas, LTC, Arty  
James D. Hawthorne, LTC, Arty

|                                    |                              |                      |
|------------------------------------|------------------------------|----------------------|
| 6. REPORT DATE<br>25 November 1967 | 7a. TOTAL NO. OF PAGES<br>48 | 7b. NO. OF REFS<br>8 |
|------------------------------------|------------------------------|----------------------|

|                           |   |
|---------------------------|---|
| 8a. CONTRACT OR GRANT NO. | 8b. ORIGINATOR'S REPORT NUMBER(S)<br>ACTIV Project No. ACA-19F              |
| b. PROJECT NO. NONE       |   |
| c.                        | 8d. OTHER REPORT NO(S) (Any other numbers that may be assigned this report) |
| d.                        | NONE  |

10. DISTRIBUTION STATEMENT  

|                                 |   |
|---------------------------------|---|
| 11. SUPPLEMENTARY NOTES<br>NONE | 12. SPONSORING MILITARY ACTIVITY<br>US Army Vietnam |
|---------------------------------|---|

13. ABSTRACT

This evaluation was conducted to determine what changes could improve the organization and employment of the Medical Company (Air Ambulance), TOE 8-137E, operating in support of counterinsurgency operations in Vietnam. Specific study objectives were to describe the performance of the Medical Company (Air Ambulance), and determine what changes in personnel and equipment authorization, methods of employment, or organization, if any, would improve the operational effectiveness of the company. The evaluation was conducted in the II Corps Tactical Zone and the southern portion of the I Corps Tactical Zone in Vietnam.

Elements of the Medical Company (Air Ambulance) were deployed on a permanent basis in three widely separated locations, requiring three helicopter platoons to duplicate the company effort in administration, operations, aircraft maintenance, supply, and motor maintenance. It was concluded that, when the tactical situation and mission requirements permit, the effectiveness of the company would be improved by basing the entire unit at one location and employing platoons or sections at distant points as required for limited periods of time only. It was recommended that the company be organized under TOE 8-137G modified to consolidate the four aircraft maintenance sections into one section, provide a platoon headquarters for the helicopter platoons, delete the air traffic control section from the operations platoon, and provide additional administrative, flight operations, and aircraft maintenance personnel. Minor equipment changes were also recommended.

~~UNCLASSIFIED~~

Security Classification

| 14. KEY WORDS   | LINK A |    | LINK B |    | LINK C |    |
|---|--------|----|--------|----|--------|----|
|   | ROLE   | WT | ROLE   | WT | ROLE   | WT |
| Field Evaluation of the Medical Company (Air Ambulance) |        |    |        |    |        |    |