

UNCLASSIFIED

AD NUMBER

AD828569

LIMITATION CHANGES

TO:

Approved for public release; distribution is unlimited.

FROM:

Distribution authorized to U.S. Gov't. agencies and their contractors; Critical Technology; SEP 1967. Other requests shall be referred to Rome Air Development Center, Attn: EMATP, Griffiss AFB, NY 13440. This document contains export-controlled technical data.

AUTHORITY

USAF ltr, 17 Sep 1971

THIS PAGE IS UNCLASSIFIED

AD828569

RADC-TR-67-153
Final Report



FPS-85 TUBE IMPROVEMENT PROGRAM 4CPX250K

Maurice L. Mullin
Robert D. Culbertson

EIMAC, Division of Varian Associates

TECHNICAL REPORT NO. RADC-TR-67-153
September 1967

This document is subject to special export controls and each transmittal to foreign governments, foreign nationals or representatives thereto may be made only with prior approval of RADC (EMLI), GAFFB, N.Y. 13440

DDC
RECEIVED
MAR 21 1968
REGISTERED
G

Rome Air Development Center
Air Force Systems Command
Griffiss Air Force Base, New York

When US Government drawings, specifications, or other data are used for any purpose other than a definitely related government procurement operation, the government thereby incurs no responsibility nor any obligation whatsoever; and the fact that the government may have formulated, furnished, or in any way supplied the said drawings, specifications, or other data is not to be regarded, by implication or otherwise, as in any manner licensing the holder or any other person or corporation, or conveying any rights or permission to manufacturer, use, or sell any patented invention that may in any way be related thereto.

ACCESSION FOR		
CPST?	WHITE SECTION	<input type="checkbox"/>
DDC	BUFF SECTION	<input checked="" type="checkbox"/>
ORAI HOUNCED		<input type="checkbox"/>
JUSTIFICATION		
BY		
DISTRIBUTION/AVAILABILITY CODES		
DIST.	AVAIL.	and/or SPECIAL
2		

Do not return this copy. Retain or destroy.

FPS-85 TUBE IMPROVEMENT PROGRAM 4CPX250K

**Maurice L. Mullin
Robert D. Culbertson**

EIMAC, Division of Varian Associates

**This document is subject to special
export controls and each transmittal
to foreign governments, foreign na-
tionals or representatives thereto may
be made only with prior approval of
RADC (EMLI), GAFB, N.Y. 13440**

FOREWORD

This final technical report under contract AF30(602)-4038, System 496L, was prepared by EIMAC, Division of Varian Associates, San Carlos, California. The work covered the period from 1 March 1966 to 1 March 1967.

This report is not releasable to the Clearinghouse for Federal Scientific and Technical Information because it discusses the improvement of a commercial tube used in a radar set which might be of future application to military systems.

This technical report has been reviewed and is approved.

Approved: 
MERTON C. KRAFT
Project Engineer

Approved: 
THOMAS S. BOND, JR.
COL. USAF
Chief, Surveillance & Control Division

FOR THE COMMANDER: 
IRVING M. GABELMAN
Chief, Advanced Studies Group

FINAL REPORT

4CPX250K TUBE IMPROVEMENT PROGRAM

MARCH 1, 1966 TO MARCH 1, 1967

CONTRACT NO. AF30 (602) -4038

TABLE OF CONTENTS

<u>SECTION</u>	<u>DESCRIPTION</u>	<u>PAGE NUMBER</u>
I	ABSTRACT	1
II	PURPOSE OF THE PROGRAM	2
III	NARRATIVE AND DATA	4
	A. GENERAL	4
	1. Personnel on the Program	6
	B. NARRATIVE AND DATA	6
	1. Mechanical Design	6
	2. Beryllia Ceramics	13
	3. High Voltage Arcing	13
	4. Film Cathode Coating	16
	a. Life Test Results	19
	b. Conclusion	21
	5. Binder Material Evaluation	22
	a. The Effect of Varying Amounts of Binder Material in Cathode Spray Mix	22
	b. Effect of Various Binder Solvents	23

TABLE OF CONTENTS
(Cont.)

<u>SECTION</u>	<u>DESCRIPTION</u>	<u>PAGE NUMBER</u>
	c. Results of Binder Material Evaluation	24
	d. Conclusion	25
6.	The Investigation Internal Tube Electronics by Computer Analysis and the Correlation of this Work with the Practical Aspects of Tube Fabrication	25
	a. Analyze "Ideal" 4CPX250K	27
	b. Analyze "Non-Ideal" 4CPX250K	40
	c. Analysis of Four "Non-Ideal" Actual Tubes	43
	d. Conclusion	50
7.	The Optimization of Internal Tube Materials, Processing and Aging Including Ion Pump Exhausting	52
	a. Effect of Silver Plating on Gas in Sealed Tubes	52
	b. The Effect of a Getter on Gas in Sealed Tubes	54
	c. Darkened Heaters	55
	d. Ion Pump Exhausting	62
	e. Dispenser Cathodes	74
8.	Evaluation Test Program to Test the Effects of Improvements	79

TABLE OF CONTENTS
(Cont.)

<u>SECTION</u>	<u>DESCRIPTION</u>	<u>PAGE NUMBER</u>
	a. Power Gain Testing	79
	b. Life Test and Arcing Results.	86
	c. Life Testing With Regard to Sublimation of Cathode Material	89
	d. Arc Protection	90
	9. Delivery of Tubes	94
IV	CONCLUSIONS	95

TABLE OF FIGURES

<u>FIGURE</u>	<u>DESCRIPTION</u>	<u>PAGE NUMBER</u>
1	Cross Sectional Drawing of Tube	5
2	Drawing of Old Stem Assembly & New Stem Assembly.	8
3	Knife Edge Seal vs. No Knife Edge Seal	10
4	Headers With 46 Alloy & P-51 Nickel Center Pins	12
5	Cross Section of Standard Design & New Design Anode Seal.	15
6	Film Cathode Punch and Die	18
7	Model of 'Ideal' 4CPX250K Beam Element.	31
8	Computed Electron Trajectories, 4CPX250K	34
9	Continuation Along Axis of Figure 8	35
10	Current Density Distribution in Beam Near Cathode Plane of 'Ideal' 4CPX250K	37
11	Current Density Distribution of Intervals Along Beam of 'Ideal' 4CPX250K	38
12	Space Potential at Beam Center and Through Centerline of Grids, 'Ideal' 4CPX250K	39
13	Computed Electron Trajectories, 'Non-Ideal' 4CPX250K, Model 2C	42
14	Current Density Distribution in Beam Near Cathode Plane, For All Models Studied	44
15	Photomicrograph of Tube Section	46
16	Cathode Current Density Distribution	48

**TABLE OF FIGURES
(Cont.)**

FIGURE	DESCRIPTION	PAGE NUMBER
17	Electron Trajectories	51
18	Electron Trajectories	52a
19	Electron Trajectories	52b
20	Electron Trajectories	53
21	Final Getter Design.	56
22	Dark Heaters.	60
23	Ion Pump Station	63
24	Ion Pump Station	64
25	Residual Gas Analyzer	72
26	M.S. Plot	73
27	Cross Section of Dispenser Cathode	76
28	Power Gain Tester	80
29	Block Diagram of Power Gain Tester	81
30	Temperature Measuring Vehicle	91
31	Temperature Profile.	92
32	Crowbar vs Fuse Circuitry.	93

EVALUATION

FPS-85 TUBE IMPROVEMENT PROGRAM 4CPX250K

The 4CPX250K is a negative grid tetrode electron tube currently being used as the final pulsed R.F. Amplifier in the AN/FPS-85 Space Track Radar.

Initially the 4CPX250K carried a warranty of (a) 3000 hours for failure due to power out decrease of 3 db; (b) 1000 hours for failure due to arcing; Ten (10) arcs being end of life.

The objective of this program was to investigate the areas where possible improvements could be made in order to provide tubes that would operate in the FPS-85 for a minimum of 4000 hours with a maximum of 10 arcs and a power output decrease not to exceed 3db. Also stressed in this program was the improvement of mechanical strength of the cathode leader assembly.

A design modification using a more unitized construction and the utilization of alloys having lower yield strength has minimized the possibility of tube loss from breakage due to rough handling and socket misalignment. The overall results of mechanical changes has led to a much more rugged tube not only for the FPS-85 use but also for any future military applications.

Design changes to mitigate the arcing problems were primarily concerned with the cathode and the screen grid-to-anode insulator. Experiments with various cathode materials and techniques resulted in the decision to use a sprayed cathode, machined to precise tolerance thereby reducing the chance of arcs due to uneven cathode surface. Test results indicated that this was a preferred technique.

A change in design of the screen grid-to-anode insulator seal area has resulted in a reduction of voltage gradients in the region of screen grid thereby reducing by a large factor the chance of arcs originating from this source.

The area of arc reduction was also investigated by way of a computer program to determine the effect of electrode spacing and alignment on cathode current densities. The results of this program proved conclusively that tight tolerances of electrode geometry are necessary for arc reduction.

Another problem area investigated was the decrease in power output due to evaporated cathode material condensing on the screen grid-to-anode insulating ceramic. The use of darkened heaters allows the cathode to operate at a more uniform temperature throughout the useful life of the tube. Since there would be no increase in cathode temperature during life, the amount of vaporized cathode coating would be substantially reduced.

Although the final results of this program will not be known until extensive life testing has been done at Bendix and at the AN/FPS-85 site, it is indicated from the limited testing done at Kimac during the course of this program that the results of this investigation will provide tubes that will have no difficulty in providing 4000 hours of useful life.

Merton C. Kraft
MERTON C. KRAFT
Project Engineer

I. ABSTRACT

A production refinement program for improving the performance, reliability and the life of the tube type 4CPX250K was conducted. The objective set for this program was to be able to produce a tube that would operate in the Radar Set AN/FPS-85 for a minimum of 4000 hours with a maximum of 10 arcs and a power output decrease not to exceed 3db during that time.

The investigation included mechanical and electrical aspects, as well as a cathode investigation, and a computer analysis of cathode current density as a function of the electrode alignment.

Processing procedures and exhaust schedules were also investigated.

As a result of this contract eight tubes in the power gain test equipment, also built under this contract, have been operating over 2000 hours satisfactorily.

Conclusions regarding methods of improving the 4CPX250K are made. These improvements have been implemented into the EIMAC tube design. Recommendations for further action are made.

II. PURPOSE OF THE PROGRAM

The purpose of this program was to improve the performance, life and reliability of tube type 4CPX250K as it is used in the Radar Set AN/FPS-85. The program was specifically directed toward extending the service life of the tube in the AN/FPS-85 to 4000 hours with a maximum of 10 arcs and a power output decrease not to exceed 3db. The main objectives of the program were as follows:

1. Improve and strengthen the mechanical design of the tube and seals to minimize failures from handling, installation, and in-socket thermal cycling.
2. Investigate high voltage arcing.
3. Study the emission and arcing characteristics of different types of cathodes.
4. Investigate internal tube electronics by computer and analysis and correlate this work with the practical aspects of tube fabrication.
5. Optimize tube processing and aging, including dry pump exhausting.
6. Evaluation Test Program to test the effects of

improvements including life testing with regard to effects of sublimation of cathode material and its relationship as to critical areas.

7. Deliver 100 completed tubes at a rate of 20 per month starting with the eighth month of the program.

In addition, two pieces of equipment were built under this contract: an ion pump exhaust station, and a ten-socket power gain tester. Both were completed and are operational.

To date eight 4CPX250K's have accumulated over 2000 hours per tube on the power gain test equipment simulating actual on-site conditions.

III. NARRATIVE AND DATA

A. GENERAL

The 4CPX250K is a compact ceramic and metal radial beam power tetrode tube used in the AN/FPS-85 radar set. This tube is used at EIMAC in a power amplifier test cavity Bendix No. 2016814-0501 under the following nominal conditions:

$E_{bb} = 5500 \text{ Vdc } \pm 3\%$	$i_b = 3.5 \text{ amps pulse max.}$
$E_{c2} = 1000 \text{ V Pulse } \pm 3\%$	$t_p = 250 \text{ } \mu\text{sec } \pm 1/2\%$
$E_{c1} = -100 \text{ Vdc to } -200 \text{ Vdc } \pm 3\%$	$D_u = .005 \text{ max } \pm 1\%$
$E_f = 6.0 \text{ Vac } \pm 1\%$	$i_f = 3.0 \text{ amps max.}$

Drive Power = 1000 watts pulsed maximum at 442 Mc/sec.

Useful power output = 10,000 watts pulsed minimum at 442 Mc/sec., 25mc \pm 3db bandwidth.

A cross-sectional drawing of the essential parts of the tube are seen in Figure 1.

This program not only resulted in an improved tube but a much greater insight was gained as to what magnitude of several mechanical variables could be allowed. Much of the information in this report could possibly be used in developing or improving other small tetrodes as well.

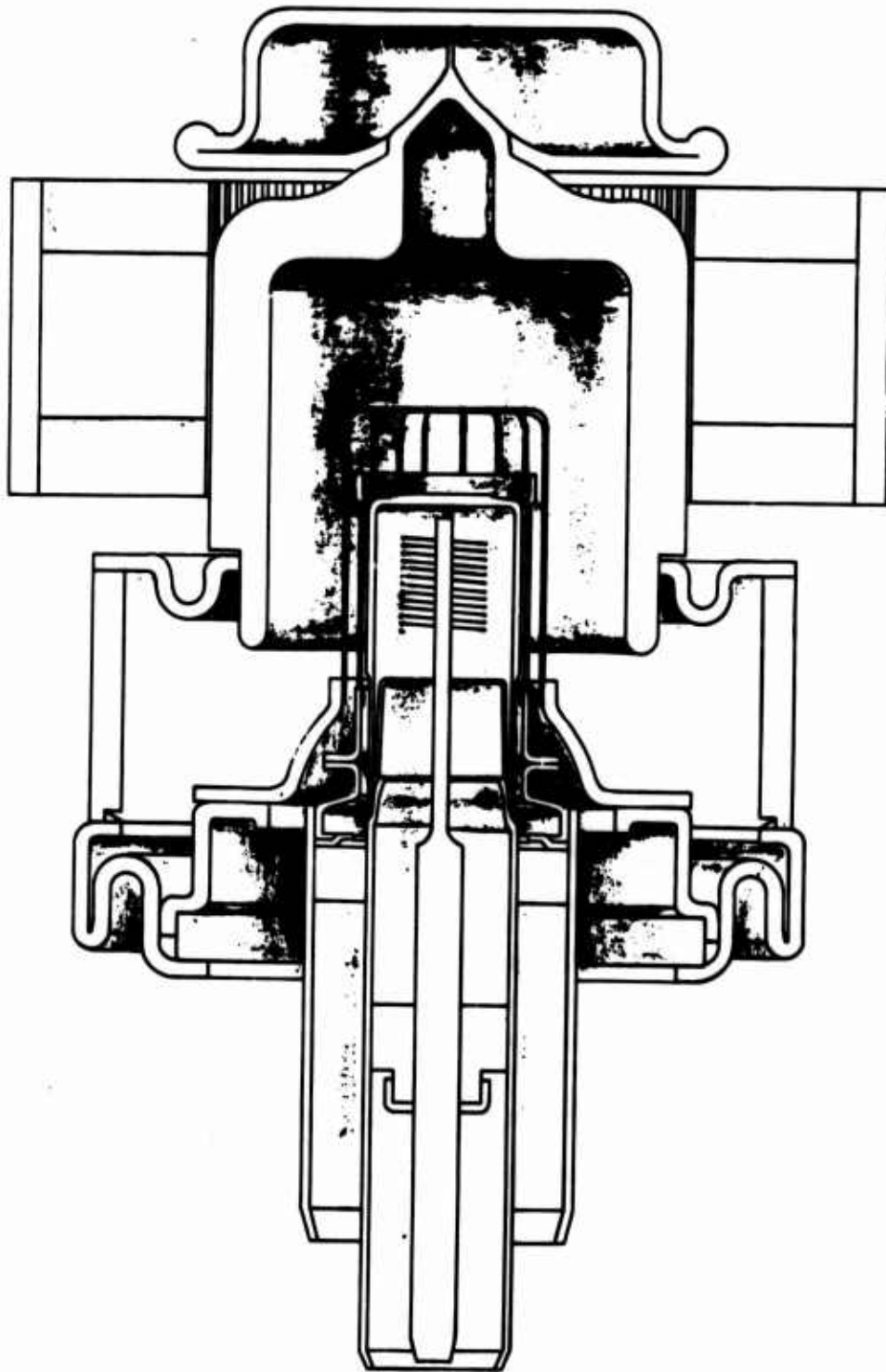

Figure 1. Cross Sectional Drawing of Tube

1. Personnel on the Program

This program was carried out under the general direction of Scott T. Porter, Manager of Production Engineering, Power Grid Tube Division. The work was carried out in both the Power Grid Tube Laboratory and Manufacturing facilities under the immediate supervision of Maurice Mullin, Project Engineer, who was assisted by Robert D. Culbertson, Principal Production Engineer. The computer study was performed in the Laboratory by William H. Sain. The film cathode effort was carried out by Anthony Barraco, Special Devices Department. The ion-pump exhaust station and the Power Gain test equipment was designed and constructed under the supervision of Jesse Souza, Equipment Engineer.

Paul D. Williams, Advisory Engineer, developed the dark heater coating process. Special assistance and consulting was obtained from William Stuart, Principal Production Engineer, who was the Project Engineer on the 4CPX250K prior to this program.

B. NARRATIVE AND DATA

1. Mechanical Design

The main effort in improving the mechanical design was concentrated in the stem assembly. Drawings of the old

construction and the new construction are seen in Figure 2. The improvements made were in the filament support area and in that part of the stem assembly that is contained by cylinders 'A' and 'A-1' in Figure. The new design facilitated better control of metallizing at point 'B-1' than point 'B'. The surface at point 'B' was difficult to metallize uniformly as it is an inside diameter of a small cylinder. An added advantage of the new design is that closer control of the concentricity of the support ends which are inserted into the tube socket is possible because of its simpler construction. This decreases the possibility of socket induced strain on the seals.

The old design base was also assembled and brazed in two sections and subsequently brazed together at point 'C'. The new design, however, is brazed as one complete assembly. This has resulted in improved concentricity control on the grid and cathode support members, which makes it easier for final tube assembly personnel to achieve uniform grid-cathode spacing control necessary to minimize cathode initiated arcs in pulse operation.

It was found in the past that fractures in the center rod ceramic occurred as a result of mishandling or forcing the

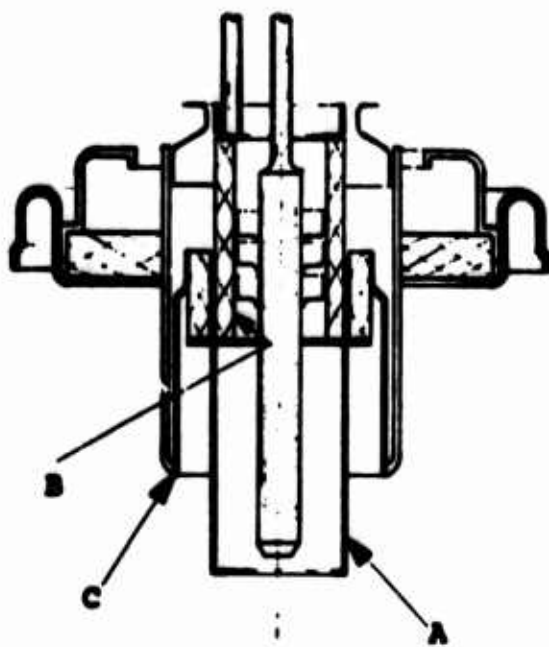

OLD CONSTRUCTION

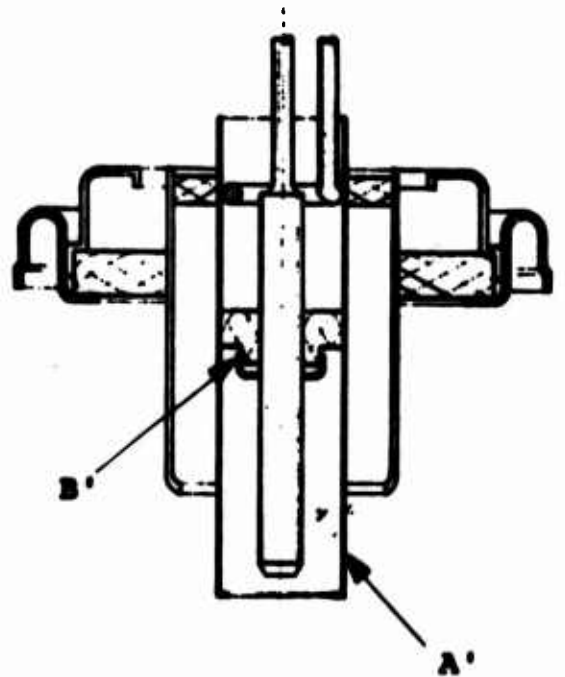

NEW CONSTRUCTION

Figure 2. Drawing of Old Stem Assembly & New Stem Assembly

tube into the socket. In order to provide a greater tolerance to center rod ceramic fractures, a knife edge type seal was investigated concurrently with an evaluation of the center rod material, per se. The idea was to lower the yield strength of the rod, or the seal, to minimize ceramic fractures.

The advantage of the knife edge seal was that the metal member has more flexibility than the O.D. seal metal member (see Figure 3.) and variations in socket dimensions would be less likely to affect the knife edge seal construction. Although the seal area of a knife edge seal is small, it has proven extremely strong and reliable. The initial test, using the knife edge construction, appeared to be satisfactory; however, the concurrent experiments evaluating the center rod material per se, described later, were also satisfactory. The knife edge seal approach was dropped in favor of the center rod material approach. The center rod material was alloy 46 (46% nickel, 54% iron). In order to eliminate the fracturing of the ceramic, P-51 nickel was substituted for alloy 46. This material has a yield strength 5,000 to 10,000 PSI lower than alloy 46. It was thought that the P-51 nickel would yield before the total stresses on the

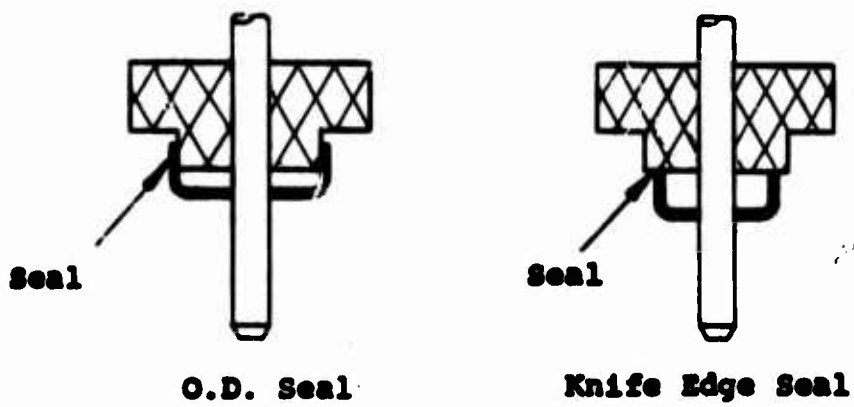

Figure 3. Knife Edge Seal vs. No Knife Edge Seal

ceramic were great enough to cause fracture.

4CPX250K headers were fabricated using both alloy 46 and P-51 nickel as center rod material. After brazing, the center rods were grasped with a pair of pliers and bent. The P-51 nickel center rods could be bent without fracture of the ceramic, while the ceramics fractured when the alloy 46 pins were bent. Figure 4 shows the results of bending the center rods. After bending, the header using the P-51 nickel alloy remains intact and the center rod ceramic has fractured on the header using a center rod of 46 alloy.

In addition to having a lower yield strength there are two other advantages of using this material. First, the P-51 nickel has less inherent voids in the base material. No voids or particulate inclusions are apparent when a cross section of the material is examined at 100X. Microscopic examination of a cross section of alloy 46 at 100X revealed many small voids distributed throughout the material that could result in virtual leaks in a tube by transport of the gas into the tube by diffusion with life, or result in a real leak if enough of the voids in the material lined up in such a way to form a 'pipe'.

The other advantage of using P-51 over alloy 46, is that

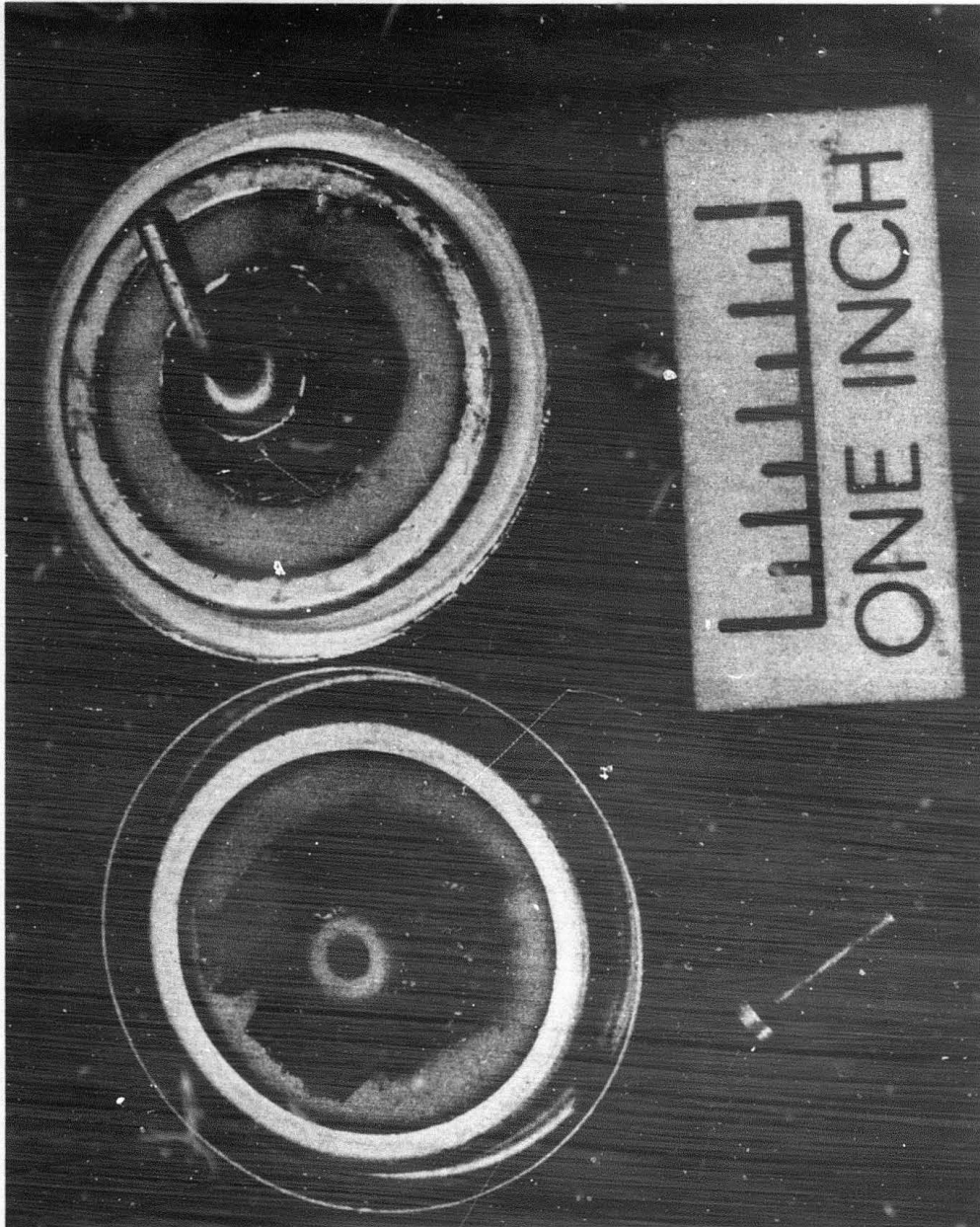

Figure 4. Headers With 46 Alloy & P-51 Nickel Center Pins

the material is wet easily by the braze alloy. The copper-silver-eutectic braze alloy does not wet alloy 46 consistently, requiring that the alloy 46 be nickel plated to assure good wetting.

Because of the good results obtained, P-51 nickel alloy is now incorporated into the 4CPX250K.

2. Beryllia Ceramics

Considerable difficulty was encountered in metallizing and brazing of the beryllium oxide stem parts. Out of a trial run of 30 assemblies, 14 were lost due to leakers. Dissection and metallurgical sectioning and examination indicated that the loss was due to inherent properties in the ceramic body, specifically, large grain size. Since further assemblies would encounter the same problem, this part of the program was discontinued.

3. High Voltage Arcing

Arcing within the tube can be grouped into three categories: cathode initiated arcs, anode initiated arcs, and arcs initiated due to high field gradients at negative electrodes. The predominant cause of arcing was from metallizing imperfections from the inside diameter of the screen grid to anode insulator. Sandblasting the inside

diameter of the ceramic with alumina particles was successful in removing imperfections at the edge of the metallizing on the butt ends of the ceramic cylinder. However, this process was tedious and time consuming. A new design seal was investigated and found to be successful in eliminating metallizing from the inside diameter of the anode to screen grid. Figure 5 is a drawing of a cross section of the standard design and the new design. The new design has a step pressed into the butt end of the ceramic on the inside diameter of the screen grid junction, thus the high voltage gradient does not "see" the metallizing imperfections and manual removal of the imperfections is not required.

Five hundred 4CPX250K tubes have been made with the new design seal and exhibited no arcing. Several tubes were constructed with a corona ring placed at the inside diameter of the screen grid seal at point 'A' on the standard design seal shown in Figure 5. Results indicated that the corona ring would not be successful in preventing screen-grid to anode arcs under power gain test conditions.

The discussion of cathode arcing is given in the cathode coating effort section later on in the report.

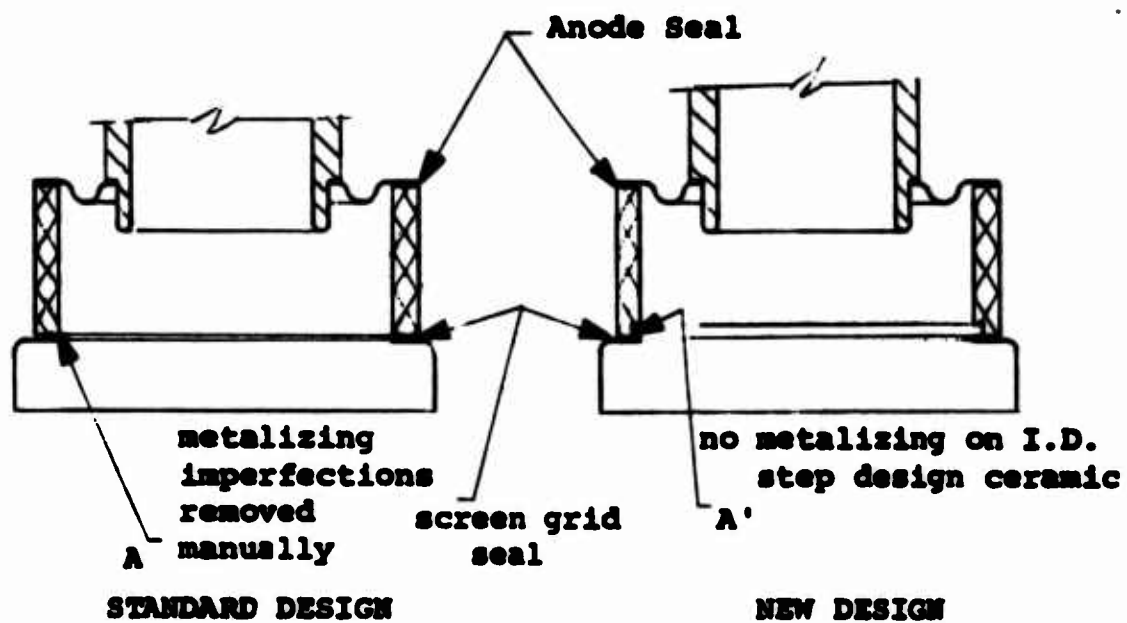

Figure 5. Cross Section of Standard Design & New Design Anode Seal

4. Film Cathode Coating

To further minimize arcing, a separate task was initiated to evaluate in the 4CPX250K a tape or film type cathode that has been used successfully in planar type transmitting tubes. A thin layer of emission carbonates and a binder material are cast onto a sheet of polyethylene. After drying, the polyethylene backing is stripped off and the resulting emission carbonates and binder tape is cut to the desired size and mounted onto the cathode can. The advantages of this system are:

1. A uniform thickness of oxide coating is achieved that can be kept to a tolerance of ± 0.0001 ".
2. A specific and uniform coating density can be maintained.
3. The surface texture is extremely smooth, eliminating the possibility of loose particles or protrusions of oxide on the cathode surface that promote arcing.

Several methods of applying film coating to cathode cans were investigated. The principal problems were:

1. Overlapping of the coating at the seam.
2. The critical quantity of solvent needed for adhesive between the cathode coating and the metal cathode can.

3. Air entrapment between the cathode coating and the cathode can, causing poor adhesion and blistering.

The overlapping seam was eliminated by careful design of a punch and die to cut the cathode coating to precisely the right size. A system of hand feeding the film under the punch and placing the cut film onto the cathode can was developed. Figure 6 shows the punch and die and the film feed arrangement.

A vapor deposition technique was investigated as a means of applying a controlled amount of solvent to the cathode can. Twelve 4CPX250K's were then made using cathodes coated by the solvent vapor technique. All tubes failed due to poor cathode coating adherence. The cause was not determined. Bell jar testing for coating adherence was continued and in all cases the coating adherence was excellent.

Another method of application was investigated, consisting of coating the underside of the film with a solution of glycerin and distilled water. The coated film was punched to the proper size and placed against the surface of the cathode can. The results of bell jar tests were excellent. Six tubes fabricated using this system passed all electrical tests. Another system was tried in order to improve coating adherence. This consisted of putting down film cathodes

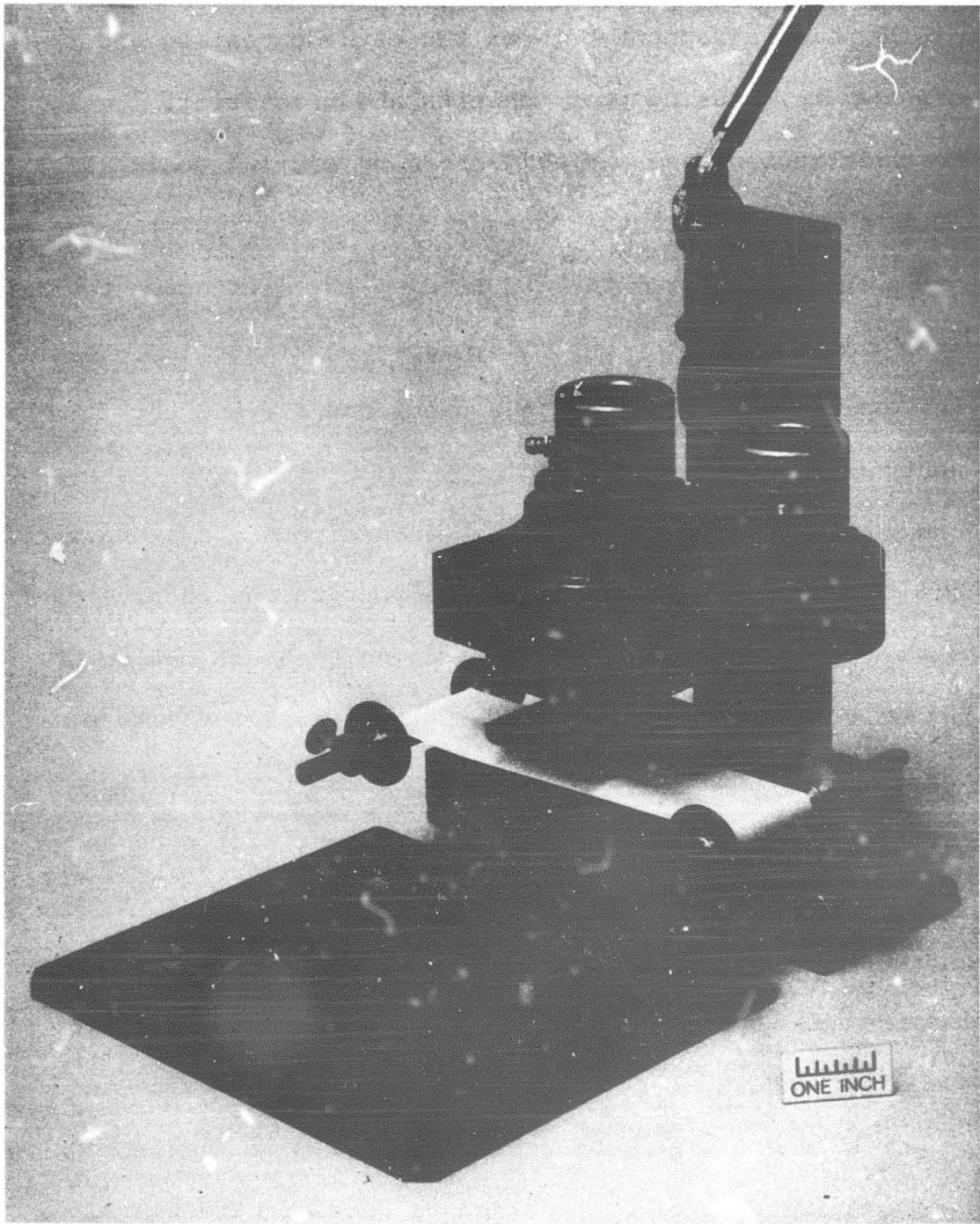

Figure 6. Film Cathode Punch and Die

on nickel cathode cans that had previously been given a thin coat of nickel powder on the surface and sintered to the base metal¹ in order to improve coating adherence. The film of emitting material was applied to the nickelated cathode by using a combination of alcohol and distilled water applied directly to the film by means of a soft polyethylene collar. The tape was cut to encircle the can. Twenty cathode cans of the correct size for tube spacing were nickelated. Cathodes prepared in the above manner were tested for adherence by heating in a vacuum bell jar to simulate a cathode form schedule. Adherence was satisfactory in every case. Ten tubes were made using cathodes prepared in this manner; all ten tubes failed standard production tests. The tubes were opened and inspected; it was found that the coating was peeled off in large sections, and it was apparent that an effective bond to the nickelate had not been achieved.

a. Life Test Results

From all of the experimental work on film cathodes, the method of application that held the most promise was that made by using a combination of glycerine and distilled

¹ A common term used for this procedure is "nickelating".

water applied directly to the emitter film by means of a soft polyethylene roller. Of six tubes made, four passed all electrical tests. The other two arced during power gain testing. Two of the four tubes that passed all tests were put on life test in the new ten-socket power gain tester. After 1,450 hours of testing, both tubes failed due to continuous arcing. The power output of both tubes had dropped to 4.5 and 5.5 kW, respectively. The test conditions were:

$$E_{bb} = 5500 \text{ V}$$

$$E_{c2} = 1000 \text{ V pulse}$$

$$E_{c1} = 110 \text{ V}$$

$$E_f = 6.0 \text{ Vac}$$

$$I_b = 3.5 \text{ Amps pulse max.}$$

$$t_p = 250 \text{ } \mu\text{sec}$$

Drive power = 1000 watts pulsed at 442 Mc/sec.

For several hundred hours prior to the onset of arcing, the tubes exhibited a temperature limited cathode condition.

A small increase in heater voltage would increase the power output significantly. Up until the time of failure, one tube arced at 475 hours and at 960 hours for a total of two arcs, and the other tube arced once at 960 hours.

Both tubes were taken apart and examined visually. The

results of the examination were:

1. The cathode coatings were thin. The base nickel could be seen throughout the coating to the extent that under a low power microscope the coating had a 'salt and pepper' appearance. There was less coating at the top half of the cathode than the bottom half.
2. The anodes were uniformly coated with nickel.
3. The gold coating on the upper one-quarter of the control grids had disappeared.

A 4CPX250K not run on life but made at the same time as the two subject tubes was opened and examined. The oxide coating was much thinner than the standard sprayed cathodes. The anode was not coated with nickel.

b. Conclusion:

Results have indicated that the film cathode approach for use in the 4CPX250K is promising, but a considerable effort is necessary before standard production is realized. In checking the film thickness of the tubes that were on life test, it was found that the thickness of the emission carbonate films was .0013". This is quite a thin coating to start with and it is conceivable that the cathodes were running slightly hotter than the standard sprayed cathodes because of the thin coating. Therefore, at this point in

time, it must be said that the film cathode has no advantage over the present standard sprayed and machined cathodes.

A life test and yield comparison between film cathodes and standard sprayed and machined cathodes is made in the Power Gain Testing section later in this report.

5. Binder Material Evaluation

a. The Effect of Varying Amounts of Binder Material in Cathode Spray Mix.

Standard production 4CPX250K's use a spray coating in which n-butyl methacrylate lacquer is used as a binder instead of the nitrocellulose lacquer used in the past. From earlier work performed at EIMAC, it was found that the original nitrocellulose binder had two main drawbacks. First, during the machining operation of the cathode coating after spraying, the coating was extremely soft and difficult to handle. The other drawback was inherent in the mechanics of binder removal during exhaust. The nitrocellulose lacquers decompose during the bakeout cycle to carbon and carbonaceous fragments. The removal of the carbon subsequently depends on oxidation to a gas (CO and CO₂) so that it may be removed from the tubes. This mechanism is not 100 percent efficient and a finite amount of carbon and carbon compound fragments are left in the tubes. The methacrylate lacquers, under

given conditions, do not decompose to carbon, but sublime to a vapor state during bakeout and cathode conversion and are pumped away. The anode of the tube using this binder material is extremely clean and exhibits no darkening. The machining of the cathode coating is accomplished by spraying on a coating thicker than the required O.D. and machining the coating on a lathe to the required outside diameter. Tubes with methacrylate binder coatings were, in general, superior to nitrocellulose coatings.

Investigations were made to determine the effect of varying the methacrylate binder concentration in the cathode spray mix. The standard binder content is 19 percent by weight of the total mix. Tests indicated that when the binder content is lowered to 6 to 10 percent, the coating tends to shrink and crack excessively when the carbonates are converted to oxides during the pumping process. However, tests of viscosity made on coatings with 6 percent binder content showed that the lower binder content coatings have more stable shelf life after several days.

b. Effect of Various Binder Solvents

Changing the binder solvents causes variations in drying time of the spray as it is applied. This affects the

texture and density of the coating. At present, three solvents are used: toluene and butyl acetate, which are fast drying; and butyl alcohol, which is slower. They are combined in a specific ratio to obtain the desired texture of coating. It was also found that the use of a small amount of plasticizer, SAIB¹ (sucrose acetate isobutyrate), improved the texture and machineability of the coating.

c. Results of Binder Material Evaluation

As a result of the foregoing experiments, a spray mix called "Special K" was made as an attempt to improve the characteristics of EIMAC 423. The difference between this mix and the standard 423 as well as a nitrocellulose binder based spray mix is shown in Table I.

	<u>EIMAC 422</u>	<u>EIMAC 423</u>	<u>SPECIAL K</u>
Carbonates	BaCO ₃ :S ₂ CO ₃	Same	Same
Binder	Nitrocellulose	n-butyl-methacrylate	Same
Binder Solvents	butyl alcohol butyl acetate	Toluene butyl alcohol butyl acetate	Dowanol EE* butyl acetate
Plasticizer	none	none	SAIB**

TABLE I

¹Eastman Kodak

* Dupont trade name for Ethylene glycol monoethyl ether.

** Eastman Kodak

Although the addition of the plasticizer improved the machineability of the coating, no other advantage could be seen. Therefore, it was decided to continue with the EIMAC 423 spray mix for historical and present day yield reasons.

d. Conclusion

It was found that a definite improvement in tube quality was achieved by adopting a methacrylate based binder rather than the nitrocellulose binder. No additional advantages were gained in quality or performance of the tube by adding a plasticizer to the mix. Therefore, the spray mix selected as standard is EIMAC 423.

6. The Investigation of Internal Tube Electronics by Computer Analysis and the Correlation of This Work With the Practical Aspects of Tube Fabrication

This task was undertaken to determine element alignment parameters required to avoid hot spots on the cathode due to uneven space current distribution. This effort was divided into two sub tasks.

Analyze the "ideal" 4CPX250K

Determine nominal operating conditions in the Bendix cavity,

especially electrode currents and voltages at the peak of the r-f cycle. Define boundary conditions for one electron beam element of the tube, under the nominal operating conditions at the peak of the r-f cycle and with the nominal (bogey) hot electrode dimensions, and punch the boundary data deck for the computer solution of the space-charge-limited condition.

Compute and plot the current, current density distribution, space for the ideal case. Compare the measured results with actual tubes. If not in reasonable agreement ($\pm 10\%$), modify boundary conditions and compute again.

Analyze "non-ideal" 4CPX250K

Compute electronic parameters (currents, potentials) for a range of electrode dimensions such as cathode-to-grid spacing, grid wire diameter and pitch, screen-to-grid spacing, screen wire diameter and pitch, and cathode areas using the boundary condition data deck obtained in analyzing the "ideal" 4CPX250K as a starting point for each perturbation of a dimension.

Find the probable range of the electronic parameters (current density, potentials, etc.) at peak operating conditions for current production 4CPX250K tubes, using the computed data and the mechanical "process capability" data for the

4CPX250K supplied by Power Grid Production Engineering.

Define the "safe" operating ranges of the electronic parameters. If these can be exceeded in tubes which are manufactured within the "process capability" of the 4CPX250K, identify the responsible mechanical or electrical variables.

a. Analyze "Ideal" 4CPX250K

1) Determine tubes of nominal operating conditions in the cavity, especially at peak of the RF cycle. Three 4CPX250K tubes were operated at the minimum conditions specified for the Power Gain test of the Tube Specification Sheet; i.e.,

$$F = 442 \pm 5 \text{mc}$$

$$E_{c1} = -100 \text{ to } -200 \text{Vdc}$$

$$E_{c2} = 1000 \text{v}$$

$$E_b = 5500 \text{Vdc}$$

$$P_d = 1000 \text{ watts}$$

$$P_o = 10 \text{ KW}$$

The video grid, screen, and plate current pulses were photographed. The average peak video currents were:

$$i_p = 3.3 \text{ amp}$$

$$i_{c2} = 0.107 \text{ amp}$$

$$i_{c1} = 0.230 \text{ ampere}$$

These average currents measurements were used to find an approximate operating RF load line in the cavity amplifier. The electrode voltages at the peak of the load line, with one kilowatt of RF drive power and ten kilowatts of useful RF output power are the following (all voltages are referenced to the cathode):

$$e_b = 1500v$$

$$e_{c2} = 1240v$$

$$e_{c1} = 75v$$

Twelve 4CPX250K tubes were selected for measurement of grid and anode currents at the voltages specified above. These measurements were made on the Power Grid Laboratory Curve Plotter with dc voltages on the screen grid and anode and a 5 microsecond, half sine wave pulse applied to the control grid. The results are shown in Table II below.

TABLE II

Serial No.	ib amperes	ic2 amperes	ic1 amperes
6CGK-0444	12.0	1.80	1.20
-0445	11.5	1.65	1.30
-0441	12.0	1.80	1.25
-0443	11.6	1.80	1.10

TABLE II
(Cont.)

Serial No.	ib amperes	ic2 amperes	ic1 amperes
6CGK-0442*	11.9	1.75	1.15
-0422	11.9	1.95	1.30
-0440	11.1	1.60	1.45
-0439	11.1	1.70	1.35
-0437*	11.5	1.65	1.25
-0434	11.8	1.70	1.22
-0432	11.0	1.70	1.10
-0421*	11.9	1.60	1.15
Average	11.63	1.72	1.25

2) Define boundary conditions for one electron beam element. The starred * tubes of Table II were opened and the outside diameters of the control grid, screen grid, and cathode were measured with an optical comparator. The diameters were taken at five vertical stations within the length of the cathode coating, and at three circumferential stations, on each tube. These measurements were averaged and corrected for the thermal expansions calculated for the estimated operating temperature. The estimated hot operating electrode dimensions and spacings are:

Grid pitch diameter-to-cathode	.0101 inch
Screen pitch diameter-to-cathode	.036 inch
Anode-to-cathode	.146 inch
Grid bar diameter	.0052 inch
Screen bar diameter	.0108 inch
Cathode diameter (coated)	.345 inch
Number of Grid and Screen bars	44
Pitch of beam element at cathode	.0246 inch

$$(P = \frac{\pi \times \text{Cath Dia}}{44})$$

One beam element is shown in Figure 7 in section, with the dimensions listed above.

3) Computing and plotting the electron trajectories, current density, and space potentials for the "ideal" 4CPX250K. The EIMAC Electron-Beam Analysis Computer Program solves Poisson's equation for mixed-boundary value problems under space charge limited conditions, for a general type of two-dimensional electron gun in a rectilinear coordinate system. To use this program, it is only necessary to specify the mechanical and electrical boundary conditions for equally-spaced mesh points on the boundaries of the system. The output of the computer program consists of a specification of the electrical potential and the space charge at each

mesh point within the boundaries, electron trajectory path coordinates, X and Y components of velocity at each set of trajectory coordinates, the current per unit length between individual trajectory paths and the total current per unit length of the electron gun, and coordinates of any pre-selected equipotential line. Additional information which may be obtained from the output include the electron transit time, current density distribution, and the electric field at any point. The boundary data deck for the average or "ideal" 4CPX250K was made up for a model which is one half a basic beam element as shown in Figure 7 bounded on the left by the cathode plane, on the right by the anode plane, at top by the radial plane of symmetry of the grid centerline and by the surface of the grids, and at bottom by the plane of symmetry half-way between grids. There was assumed to be no component of electric field normal to these planes of symmetry. The results of the computation are presented in the following section.

4) Results

1. Total cathode current was calculated and was 14.9 amperes. The average of the measured currents of 12 tubes was 14.6 amperes. Therefore, it can be assumed that

the estimated dimensions of the model are satisfactory.

2. Electron trajectories and space potential.

Figure 8 shows the electron trajectories and lines of constant potential for the 4CPX250K, as plotted from the computer output. A two-dimensional transverse section of one beam is shown with the cathode represented by the flat plane on the left of Figure 8 and the anode similarly shown as the plane to the right of Figure 9. Of the 13 trajectories calculated for each side of the beam (center line of grids to the beam center line) only trajectories 1, 2, 3, 4, and 7 are shown. Trajectories 1 and 2 strike the control grid (G1) but 3 through 13 go through the grids to focus at approximately .064 inch from the cathode (at $X=70$ mils). The total current contained in the "current tubes" between trajectories 1 and 2 and between 2 and 3 which probably will be intercepted by the control grid is 1.9 amperes. A small fraction of the second current tube may go to the screen grid (G2). The equipotential lines show that the space charge in the region between the screen grid and anode depresses the space potential by about 270 volts below the linearly extrapolated value. This potential minimum is located within the region enclosed by the 1050 volt equipotential line beyond the screen grid.

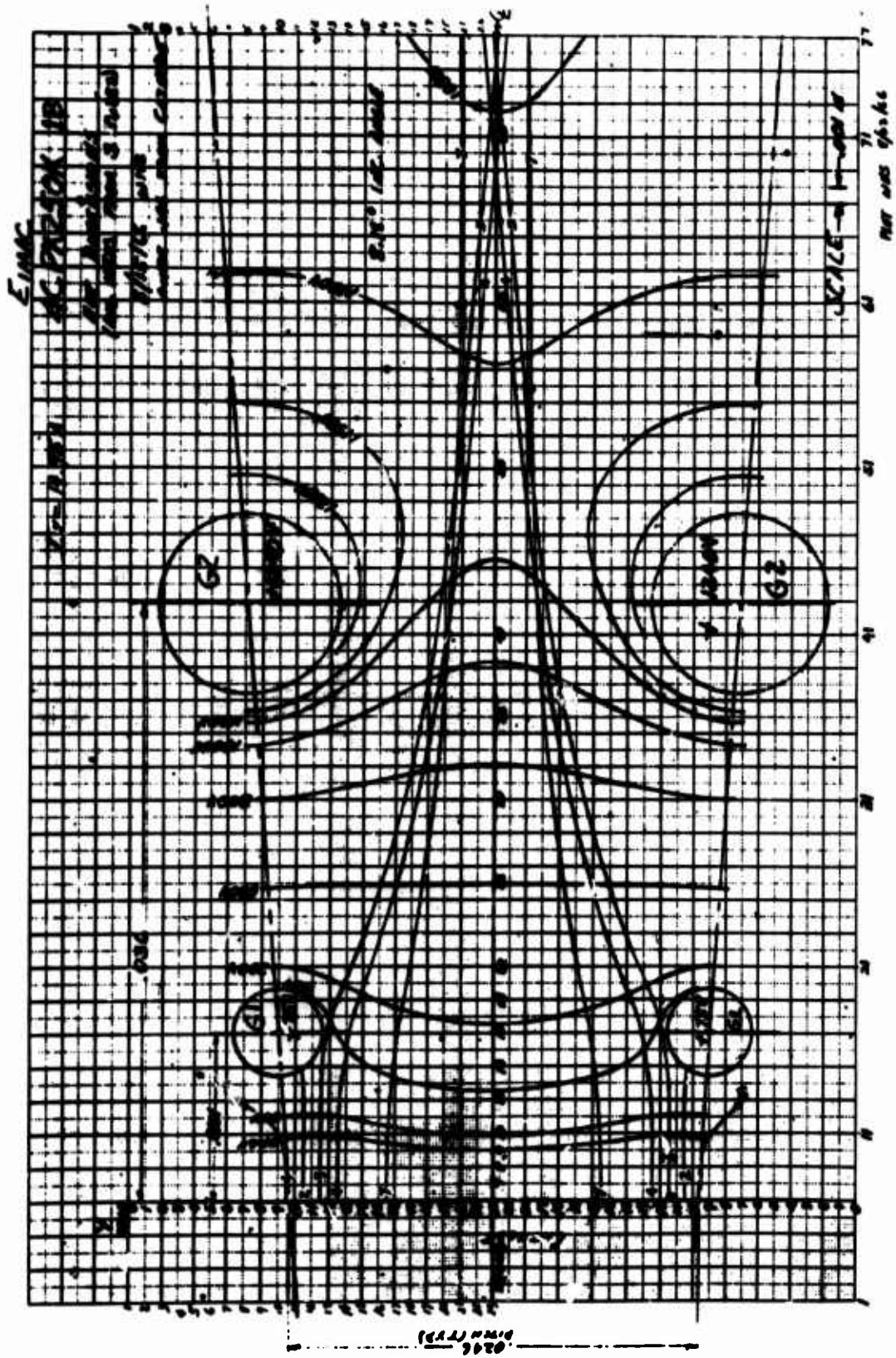

Figure 8. Computed Electron Trajectories, 4CX250K

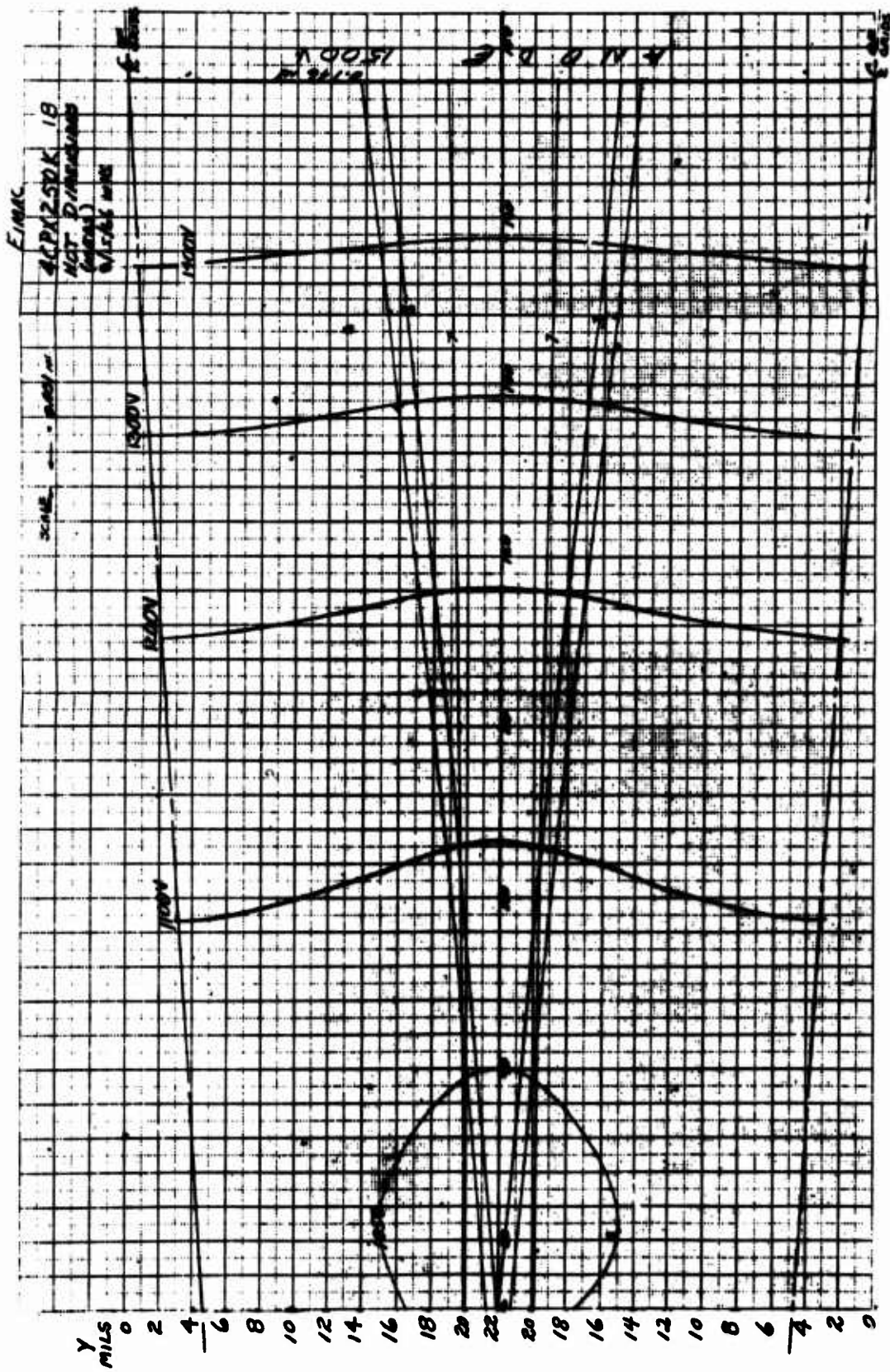

Figure 9. Continuation Along Axis of Figure 8

3. Current density. The computed current density distribution within the beam just off the cathode, taken at the 35.6 volt equipotential line shown on the trajectory plot, is shown in Figure 10. The maximum current density is 8.43 amperes per square centimeter in the center of the beam, decreasing to about 5.0 amperes per square centimeter immediately behind the control grid on the grid centerline. Figure 11 is an isometric plot of the relative current density distribution in the beam as it travels from the cathode to the anode. The current density was obtained from the product of the radial (X) velocity and the space-charge density. Y components of velocity were small and were neglected in the current density calculation. This figure shows that the beam becomes hollow with low current density at the center of the beam, as it goes between the screen grids, then broadens out as it nears the anode. The maximum current density in the tube occurs in the two peaks at .045 inch from the cathode, past the screen grid, and is 30 amperes per square centimeter, or about four times the current density just off the cathode.

4. Space Potential. Figure 12 shows a plot of the space potential as a function of the distance from the

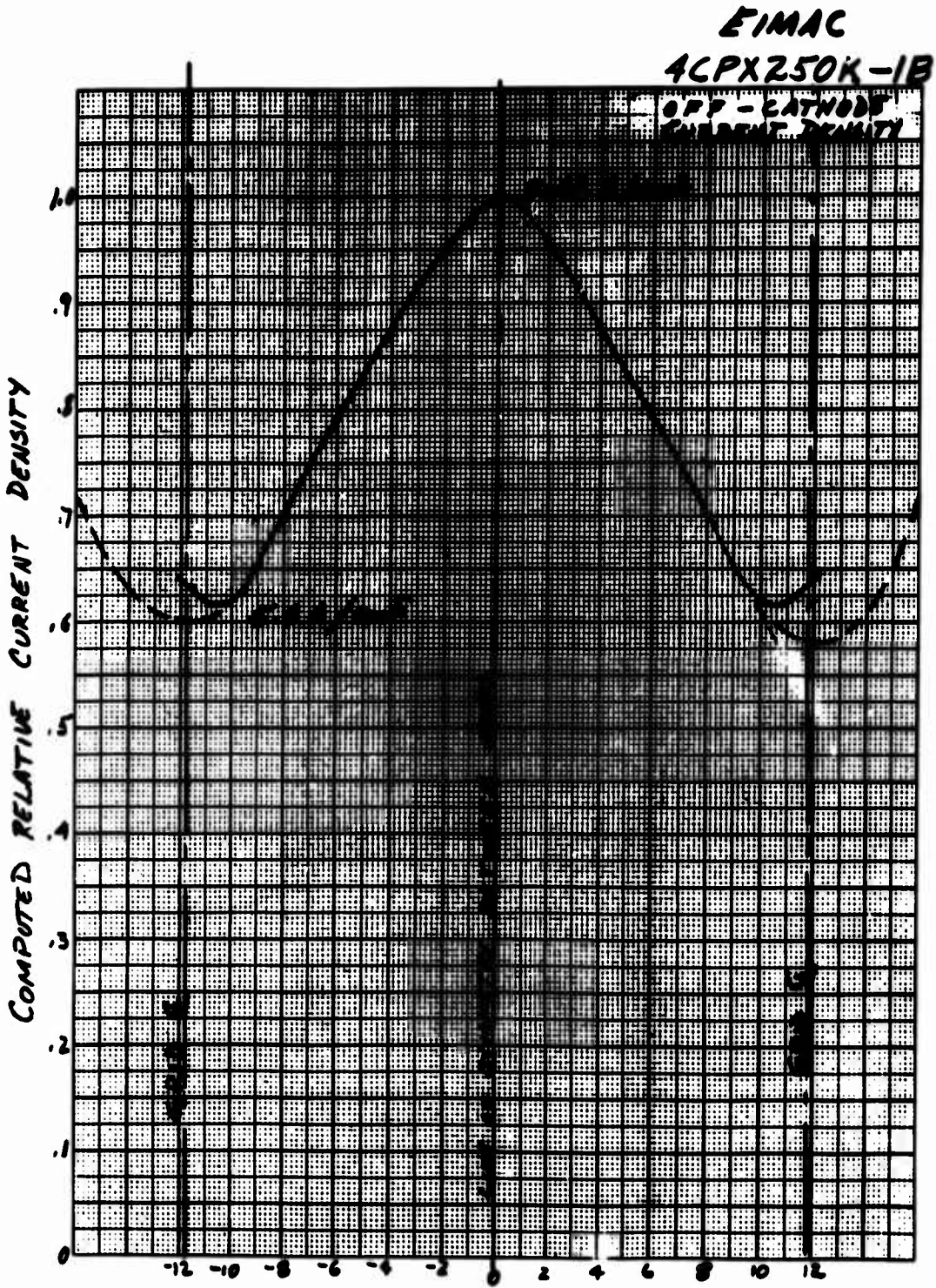

Figure 10. Current Density Distribution in Beam
Near Cathode Plane of 'Ideal' 4CPX250K

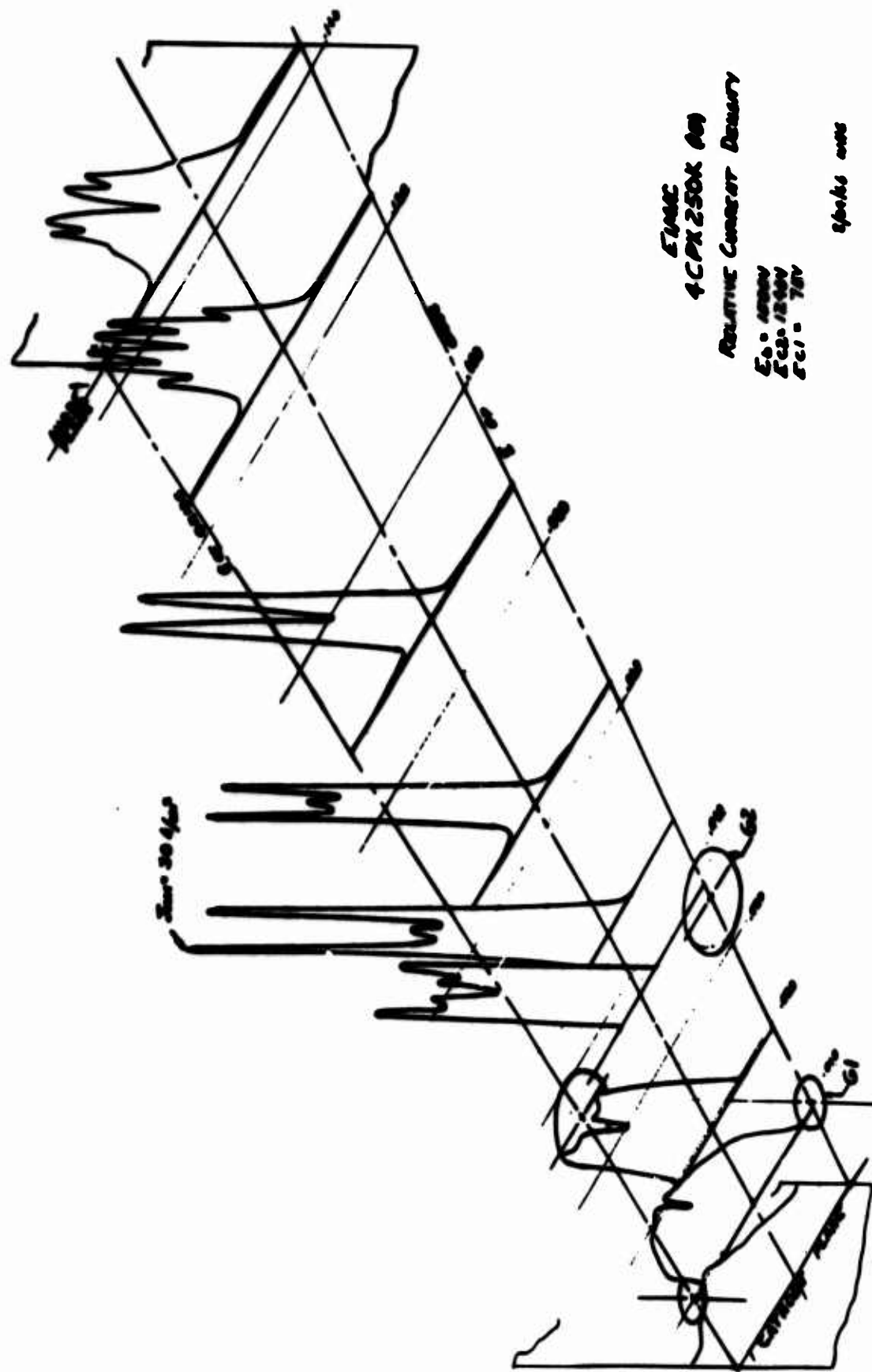

Figure 11. Current Density Distribution of Intervals Along Beam of 'Ideal' 4CPX250K

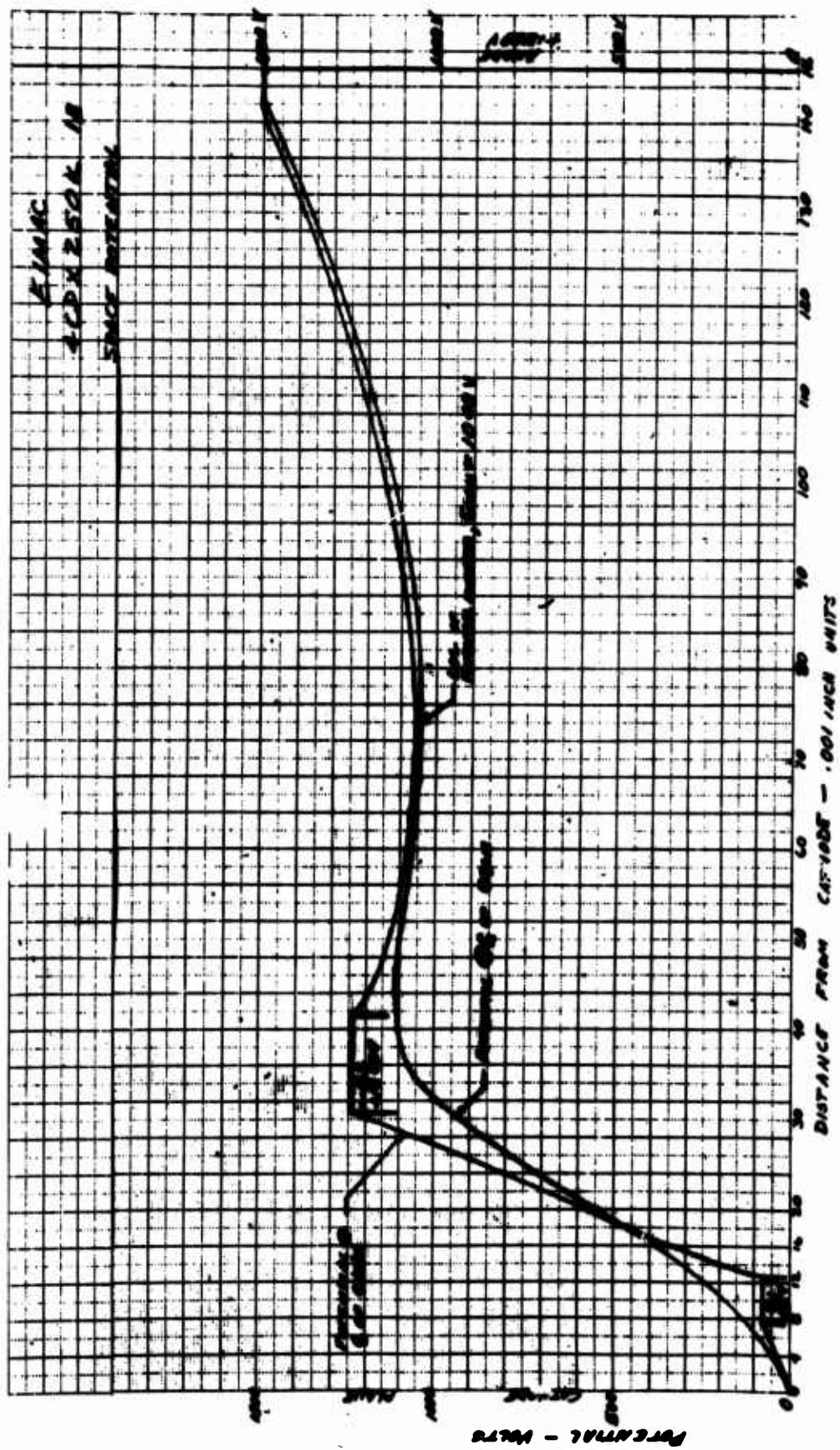

Figure 12. Space Potential at Beam Center and Through Centerline of Grids, 'Ideal' 4CPX250K

cathode, on the planes of symmetry through the centerline of the grids and through the centerline of the beam. The maximum potential gradient occurs at the surface of the control grid facing the screen grid, and is approximately 90 KV per inch.

5. Time of Flight. A numerical integration of the transit time of the electron beam under these peak voltage conditions gives the following results:

Transit time - to plane of control grid = 87×10^{-12} sec
- to plane of screen grid = 135×10^{-12} sec
- to plane of anode = 270×10^{-12} sec

The period of one wave at 442mc is 2.26×10^{-9} sec so that the transit time becomes approximately 0.75 radian.

b. Analyze the "non-ideal" 4CPX250K

In the computations reported in the preceding sections, it was assumed that the model had perfect grid alignment, that the electrode spacings were uniform and regular, and that all sections of the cathode were equally active electron emitters. Even though the calculated cathode current was very close to the measured cathode current, there was a large discrepancy in the grid currents between the calculated and measured values, especially since no screen current was predicted although the measured screen

current was 12 percent of the cathode current. Additionally, the measurements of electrode diameters of good tubes showed that control grid, screen grid, and cathode diameters can vary by several thousandths of an inch from the nominal diameter, causing variations in electrode spacings. To find the effect of these dimensional changes on the tube characteristics, four analyses were made with four combinations of tube dimensions. These dimensions and the calculated current are listed in Table III.

<u>Model</u>	<u>Electrode Spacings</u>			<u>Calculated Current</u>		
	dg1k inch	dg2k inch	dpg inch	Ik amp	Ic1 amp	Ic2 amp
1B("ideal")	.0101	.036	.146	14.9	1.9	-
2A	.0111	.038	.146	12.4	1.6	-
2B	.0111	.034	.146	14.3	1.7	-
2C	.0091	.038	.146	15.9	2.2	-
2D	.0091	.034	.146	18.1	2.3	-

TABLE III

None of these models result in any appreciable screen grid current interception; a typical example of the electron trajectories which result is shown in Figure 13 for model 2C. This figure shows that only the first three trajectories are intercepted by the control grid and that all others go

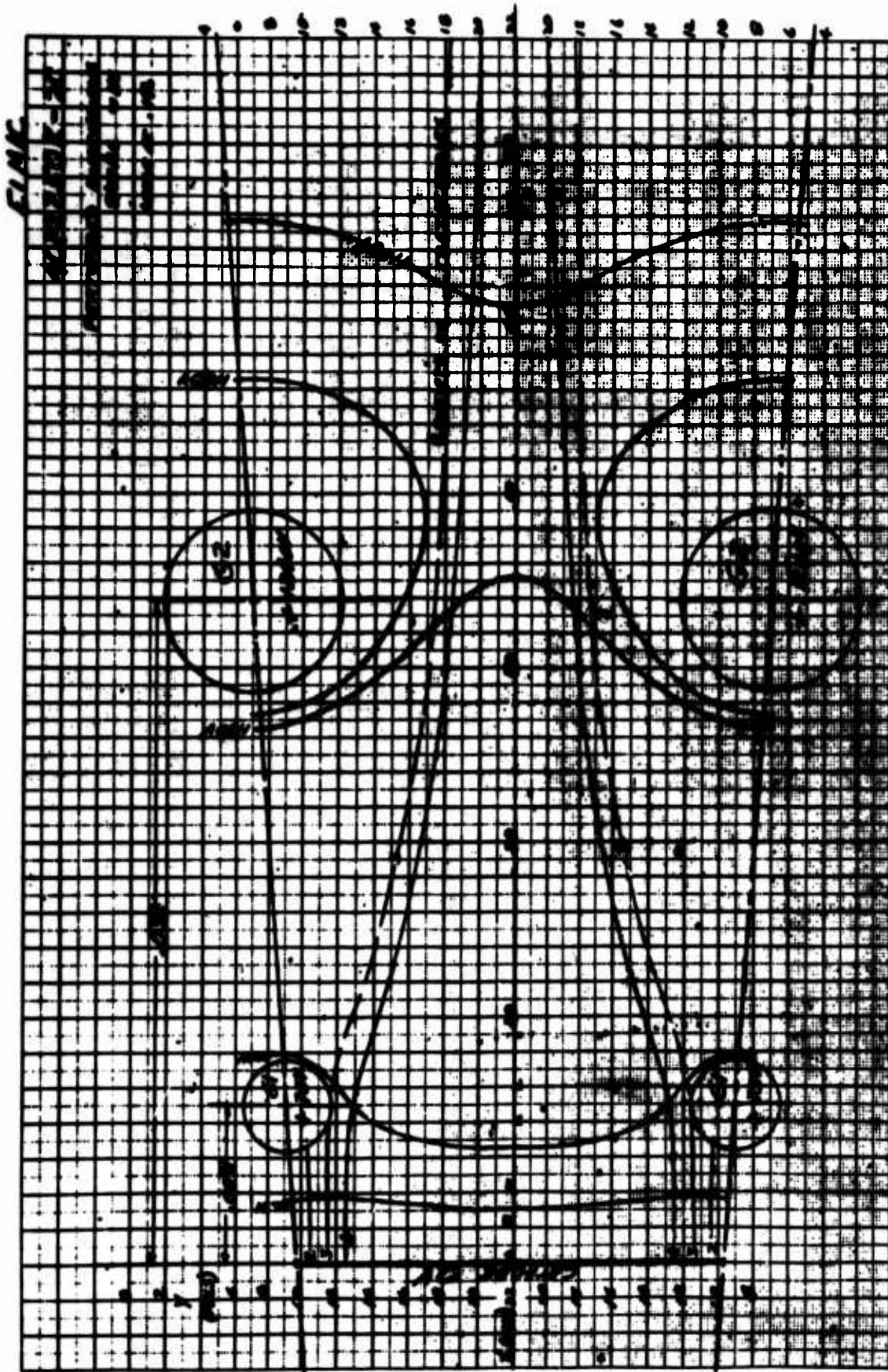

Figure 13. Computed Electron Trajectories, 'Non-Ideal' 4CPX250K, Model 2C

on through to the anode. Figure 14 shows the current density distribution off the cathode for all the models studied. The range of current density is 4 amperes per square centimeter for the minimum of model 2A, to over 10 amperes per square centimeter for the maximum of model 2D. The only differences in the two models was that the control grid in model 2A was 0.002 inch closer to the cathode, and the screen grid was 0.004 inch further away from the cathode. The range of spacings was determined solely from measurements of the diameters of the elements, assuming perfect alignment. If variations in concentricity of electrodes, twist of grids, and radial misalignment of grids are considered, these may contribute the screen grid currents. These variations were not calculated.

c. Analysis of Four "Non-Ideal" Actual Tubes

Two tubes from a good lot and two tubes which had failed the Specification Ic2 test, were opened and cast in plastic. Transverse sections were sawn from the castings of the mounted grid assemblies and then polished and examined. Measurements were made of control-grid-to-cathode spacings, screen grid-to-cathode spacing, and control grid and screen grid pitch, from photomicrographs of the sections.

EIMAC
4CPX250K
CURRENT DENSITY IN BEAM
AT CATH. SURFACE

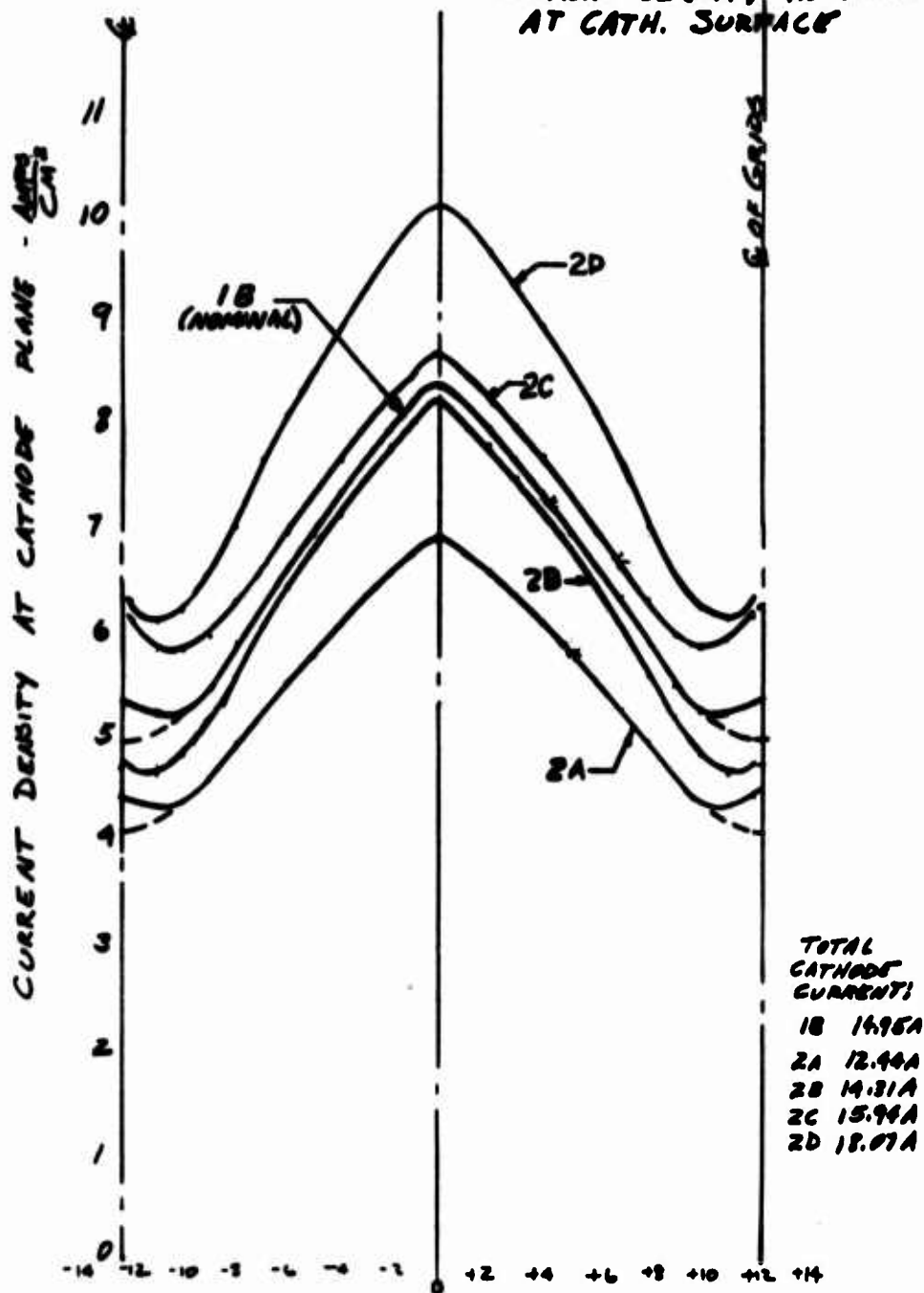

Figure 14. Current Density Distribution in Beam Near Cathode Plane, For All Models Studied

Two typical photographs of one section are shown in Figure 15. These photographs were taken 180 degrees apart on a center section of tube No. 6CGK-0422, and each represents three unit electron guns, or four grid pairs. Taking into account the thermal expansion of the tube electrodes, the deviations from the nominal or ideal dimensions of the unit electron guns of the four sectioned tubes are as listed below:

	Extreme Deviations from Nominal		
	<u>Positive</u>	<u>Negative</u>	<u>Unit</u>
Control-Grid-Cathode Spacing	+0.002	-.002	inch
Screen Grid-Cathode Spacing	+0.004	-.002	inch
Pitch, Control Grid	+0.001	-.001	inch
Pitch, Screen Grid	+0.001	-.001	inch
Angular Alignment	+1.1	-1.1	degree
Control Grid to Screen Grid	+0.004	-.004	inch

The Electron-Beam Analysis Program was used to analyze the four extreme combinations of control grid-cathode and screen grid-cathode spacings, with no angular alignment errors.

These four models were:

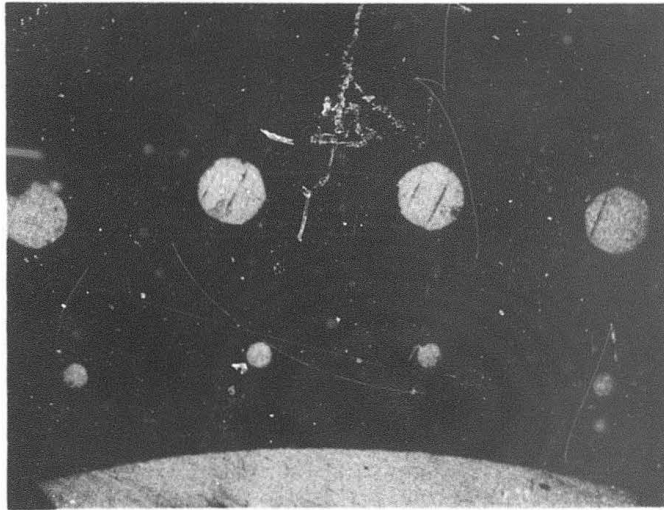

a. 0 Degrees

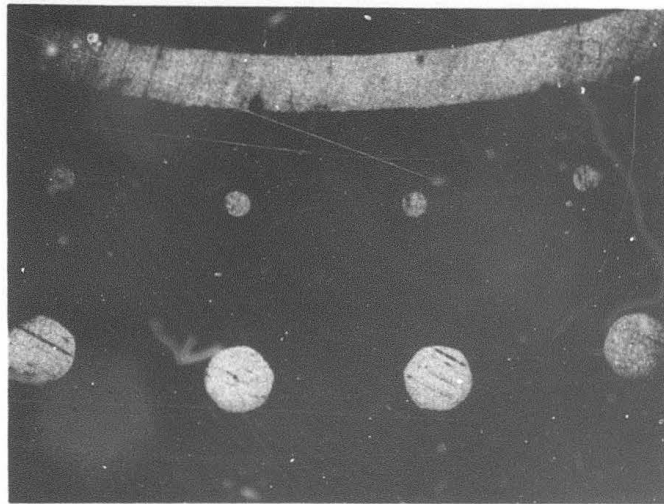

b. 180 Degrees

4CPX250K SECTIONS (38.5X)

Figure 15. Photomicrograph of Tube Section

Model	<u>Control inches</u>	<u>Grid-Cathode deviation</u>	<u>Screen inches</u>	<u>Grid-Cathode deviation</u>
3A	0.0121	+0.002	0.040	+0.004
3B	0.0121	+0.002	0.034	-0.002
3C	0.0081	-0.002	0.040	+0.004
3D	0.0081	-0.002	0.034	-0.002

Results of Analysis:

Cathode Current Density

The cathode current density distribution calculated one mesh point (.001 inch) away from the cathode surface, is shown in Figure 16 for all four models. In the center of the unit beam, halfway between grid bars, the current density varies from 6.5 amperes per square centimeter, for model 3A, to 12.7 amperes per square centimeter for 3D. Opposite the grid bars, the current density is lower, 3.7 amperes per square centimeter to 7.6 amperes per square centimeter. For a cathode with homogeneous electrical properties, this range of cathode current densities represents a twelve-to-one ratio of joule (I^2R) heating power. Although technical difficulties with the computer program data input format made it impractical to investigate models with misaligned grids (angular misalignment) at this time, the cathode

4CPX250K
Current Density in Beam
at Cathode Surface

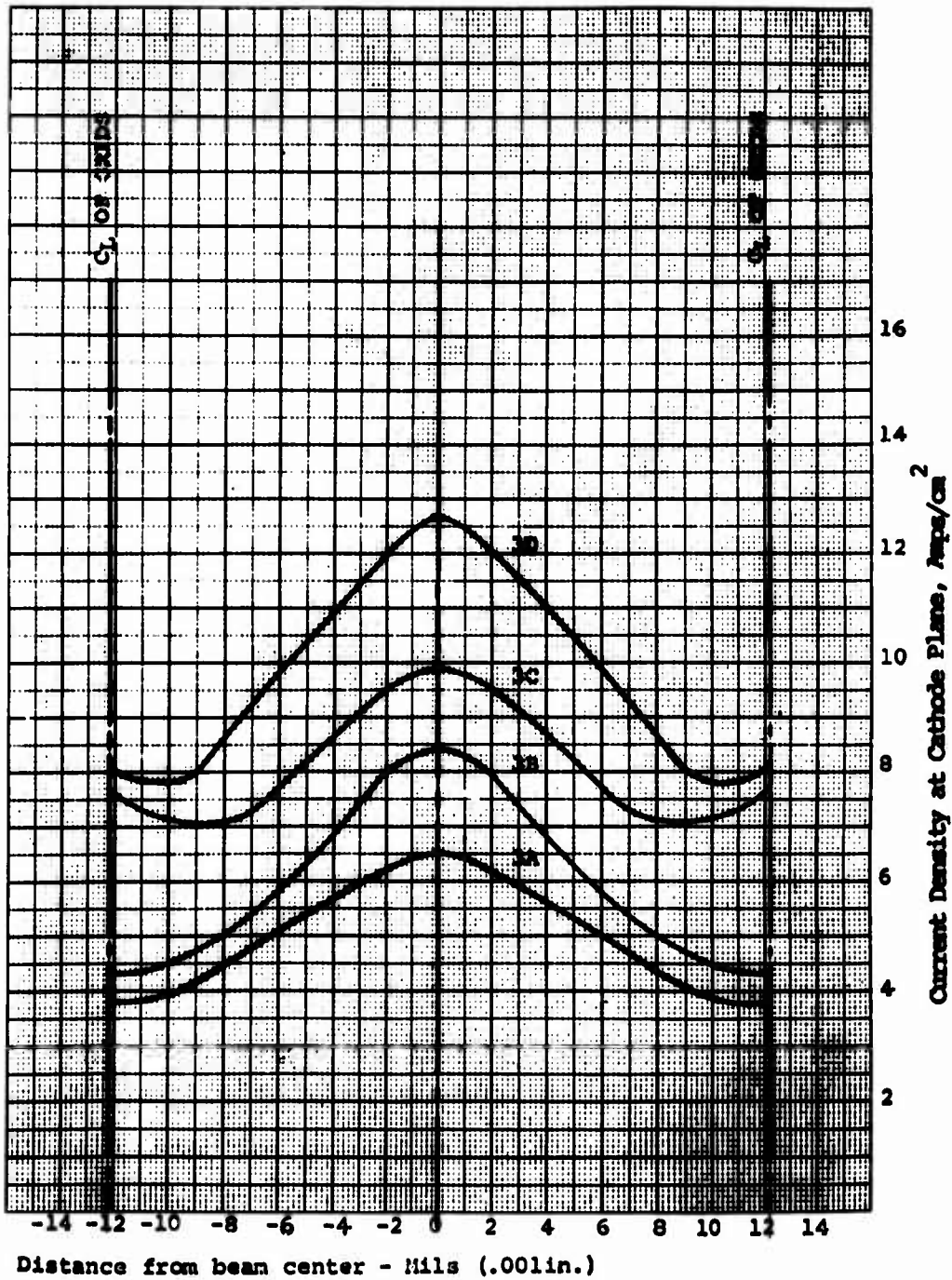

Figure 16. Cathode Current Density Distribution

current density distribution is unlikely to be affected.

Electron Trajectories

Figures 17, 18, 19, and 20 are plots of the equipotentials and electron trajectories of the four models 3A, 3B, 3C, and 3D. Model 3D has the widest beam at a point opposite the screen grid, G2. In no case is there any indicated screen grid interception. The currents calculated for each model are listed below with the average electrode currents of 12 tubes measured at the same set of voltages:

Model	Cathode Current <u>Amps</u>	Control Grid Current <u>Amps</u>	Screen Grid Current <u>Amps</u>
3A	11.1	1.03	-
3B	13.7	1.17	-
3C	18.4	3.3	-
3D	21.6	3.05	-
Average- 12 tubes	14.6	1.25	1.72

The discrepancy between the screen current observed in the tube tests, and the calculated screen current (zero) can be explained by the following effects:

1. Angular misalignment of the control grid and screen grid, on the order of 1.1 degrees (.004 inches). At present, the

program will not accept more than one value of direction of the electric field at either the upper or lower boundary, so the boundary must be a straight line rather than zig-zag.

2. Initial thermal velocities of emitted electrons, transverse to the beam and not normal to the cathode surface, which would cause spreading of the beam.

3. Secondary electron emission from the control grid. Many of the emitted electrons will be intercepted by the screen grid.

4. Electrons which pass close to the control grid and are highly deflected. These are not shown in the computer solution because of the relatively coarse (.001 inch) mesh size used. The electrons which are at or near the edge of the control grid will be intercepted by the control grid or deflected at large angles.

d. Conclusion

This work has shown that very small shifts in mechanical spacings between the control grid and cathode result in a large variance in cathode current density across the surface of the cathode. Thus it is most important that the control grid to cathode tolerances be held as close as possible to ensure long life with a minimum of arcing.

REVISIONS BY DATE & BY NUMBER & BY NAME FOR 1001-2642-11 10/14/54
@ 75 1000 1000 V RLT CURRENT BY 25 SLOPE SPECIFIED .500 PERH

FORM 817

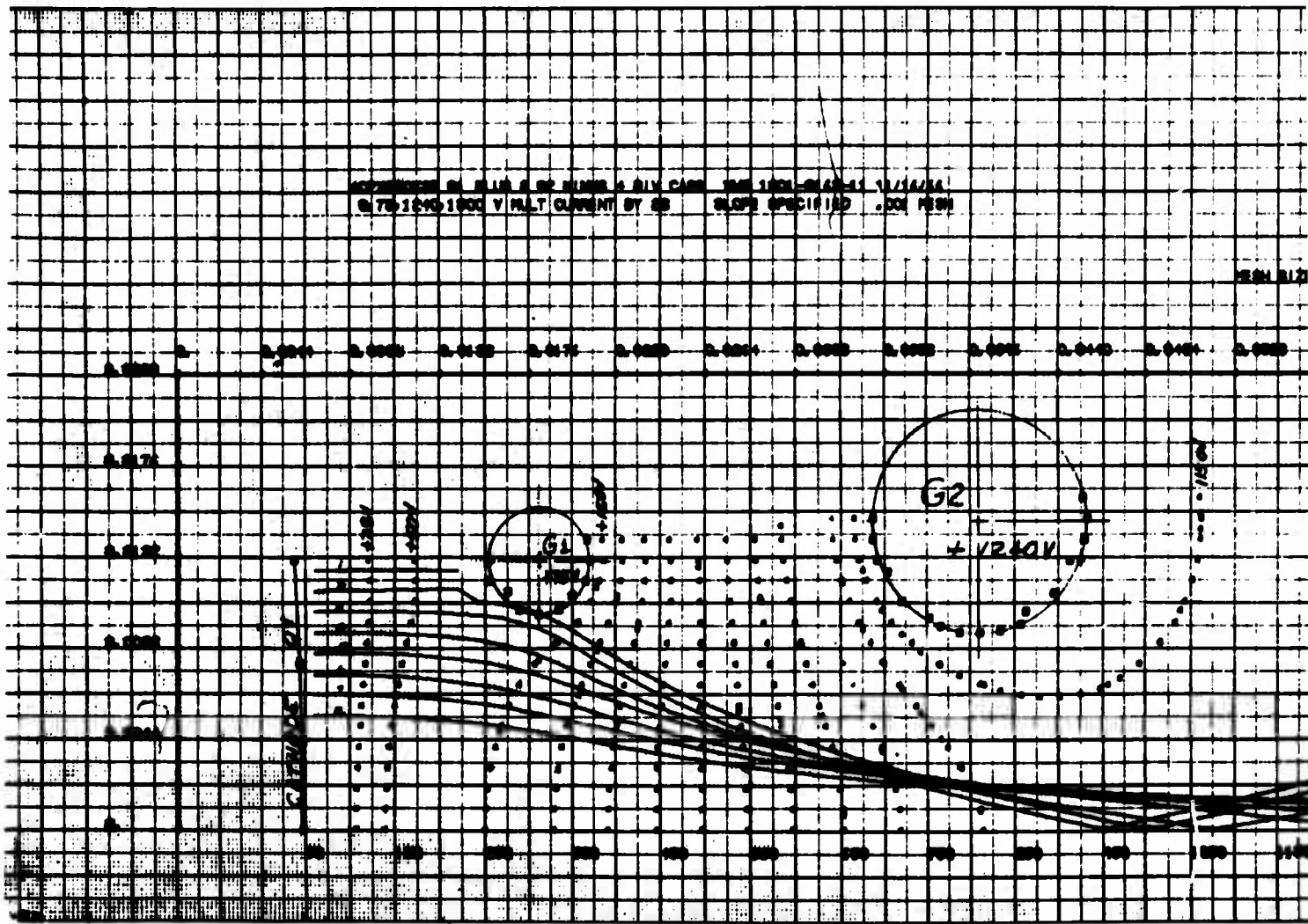

A.

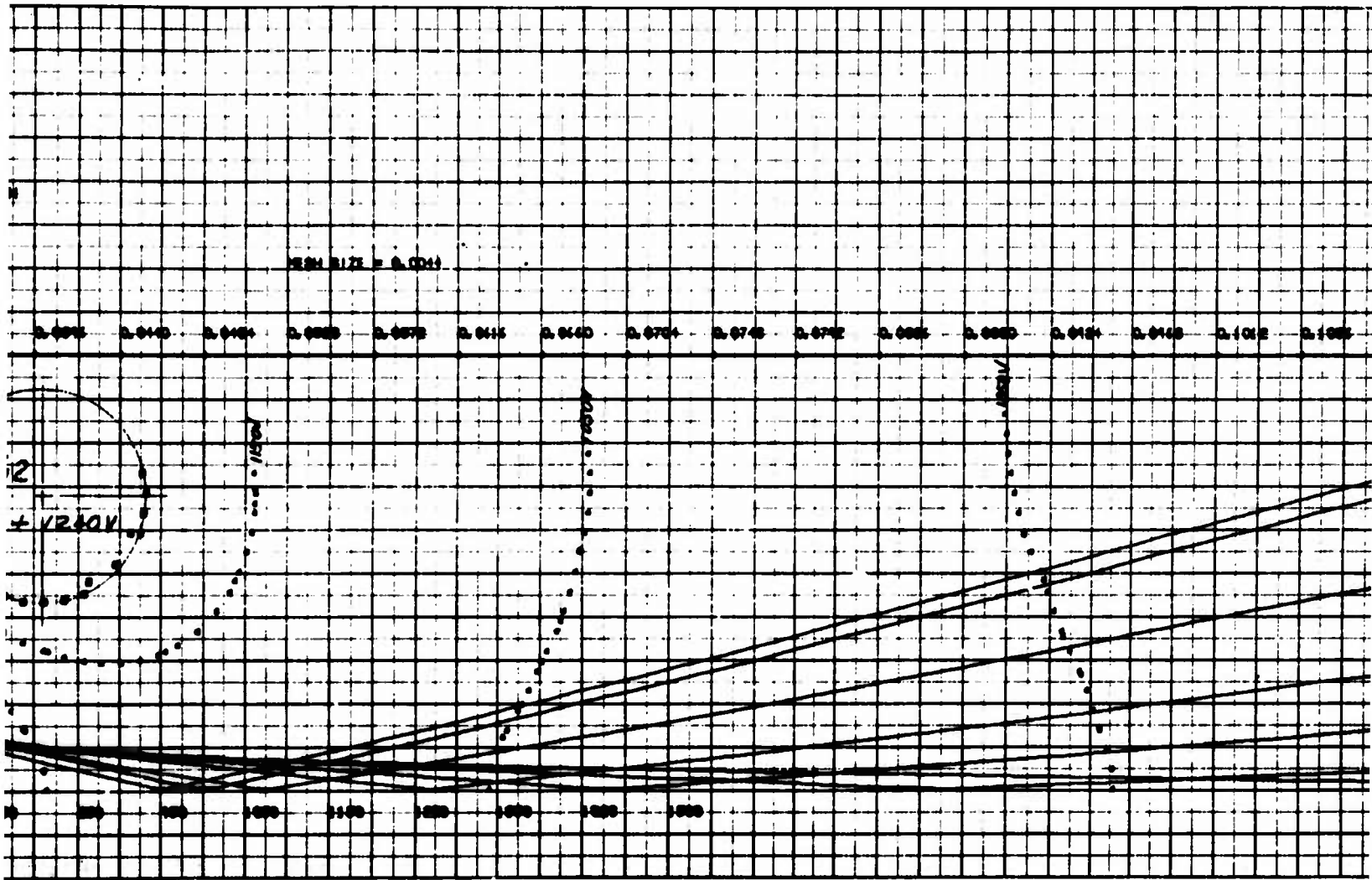

B.

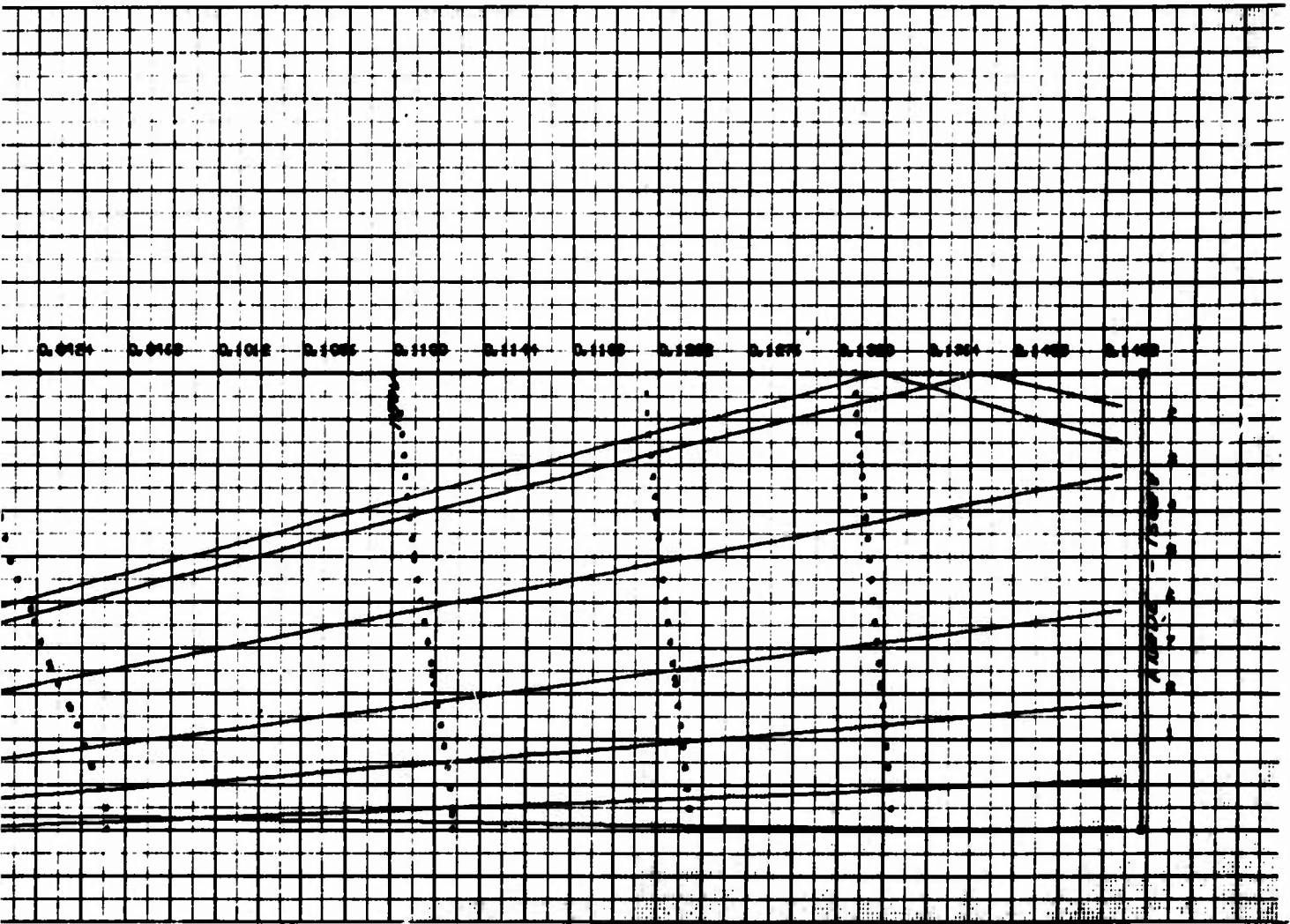

Figure 17. Electron Trajectories

C.

As a result of this work an attempt was made to tighten the tolerances on the control grid assembly, i.e. the I.D., O.D., and concentricity. 100 grids were removed from the stockroom for inspection to the tightened tolerance. The first twenty out of twenty failed to meet the tightened specification. By coincidence, we had noticed that the yield of the tubes that we were making at the time had dropped to below 75%. The loss was due to arcing in power gain testing. The 100 grids removed for tightened tolerance inspection were 100% inspected a second time to standard tolerances. Of the 100 grids, 57 passed inspection, 28 were rejected for small I.D., 2 had broken spirals, 8 were bowed, 1 was under on O.D. and 2 had bent supports. Tubes were made using the 57 control grids that passed inspection. The yield due to arcing during power gain testing went up to over 90%.

7. The Optimization of Internal Tube Materials, Processing and Aging Including Ion Pump Exhausting

a. Effect of Silver Plating on Gas in Sealed Tubes

Previous work performed at EIMAC on the 4CPX250K and similar tube types led to a conclusion that a problem exists with hydrogen that diffuses through the tube envelope. Accelerated shelf life on tubes taken from each step in manufacturing process after tube seal off indicates that final

REPRODUCTION OF THIS DRAWING IS PROHIBITED WITHOUT THE WRITTEN PERMISSION OF THE ORIGINAL AUTHOR
DISTRIBUTION IS LIMITED TO THE PERSONS SPECIFIED IN THE ORIGINAL DRAWING

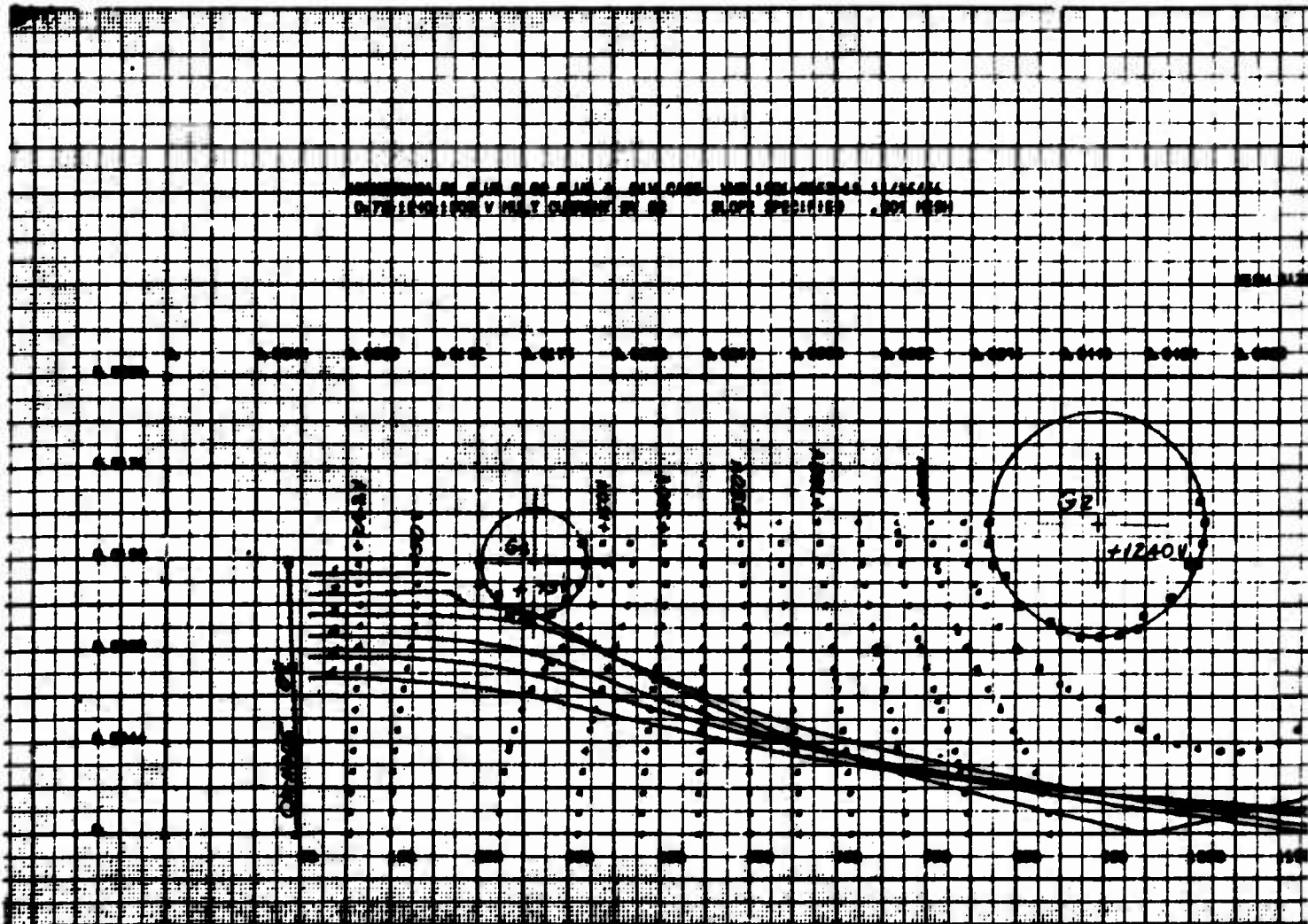

A.

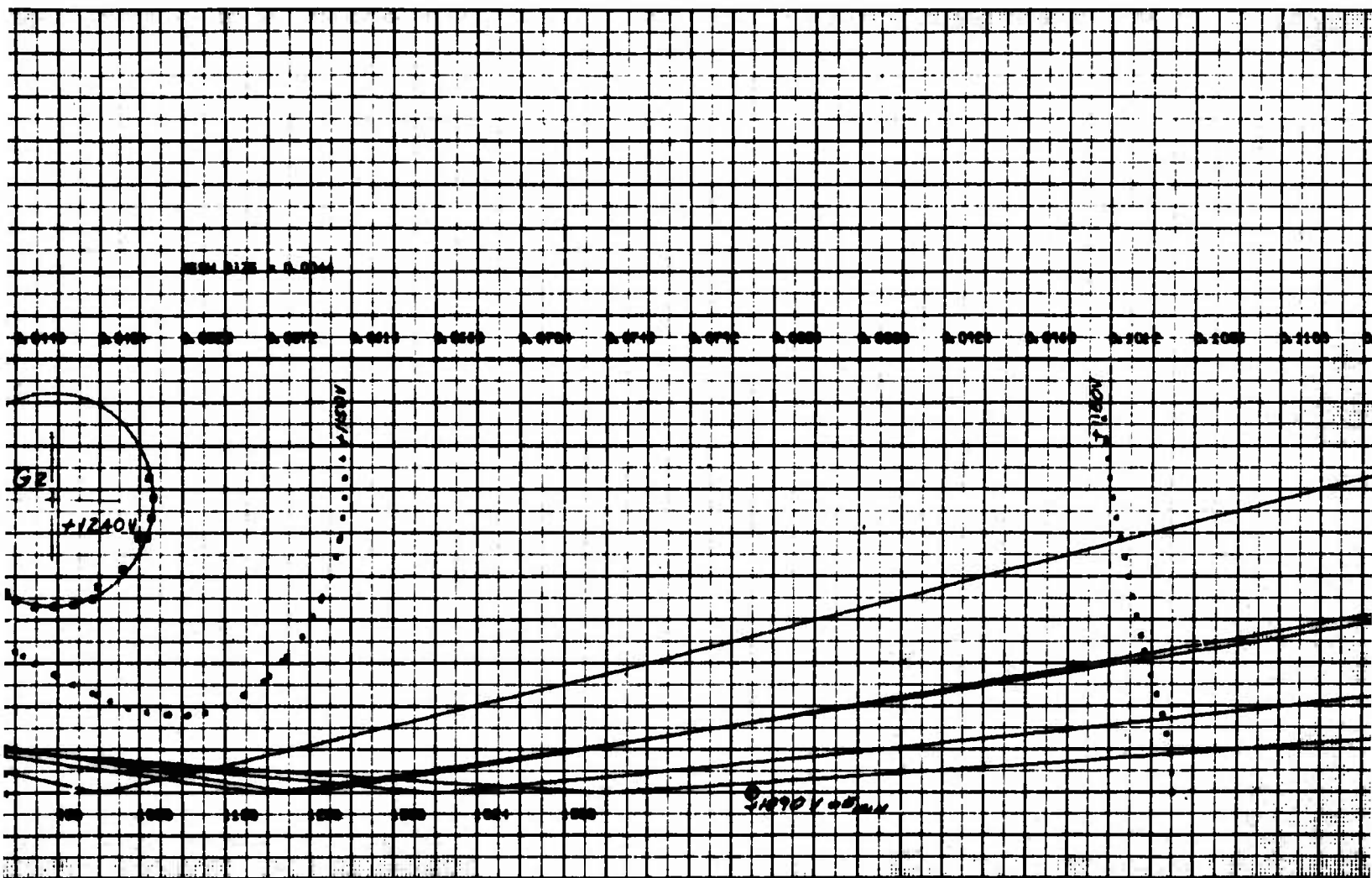

B.

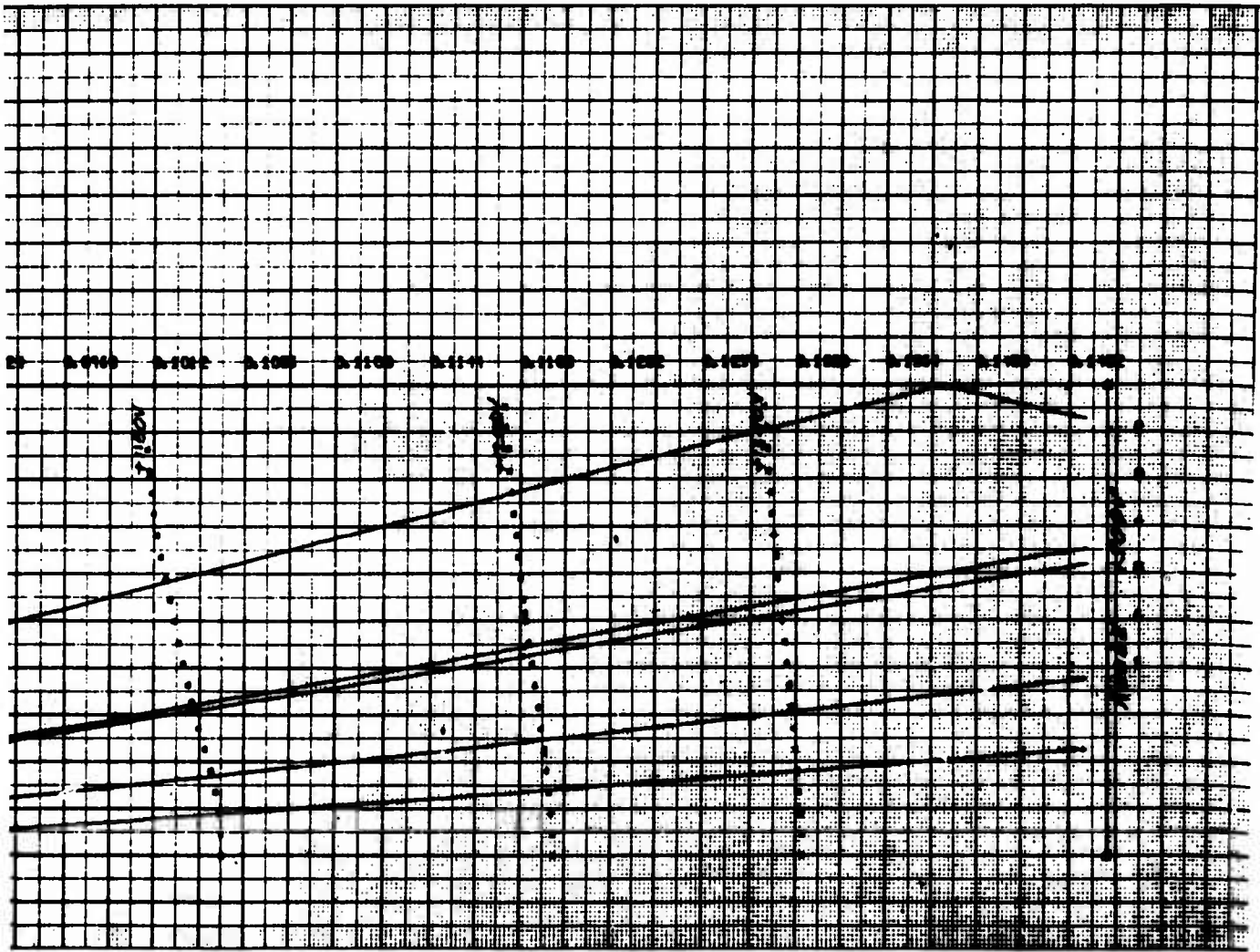
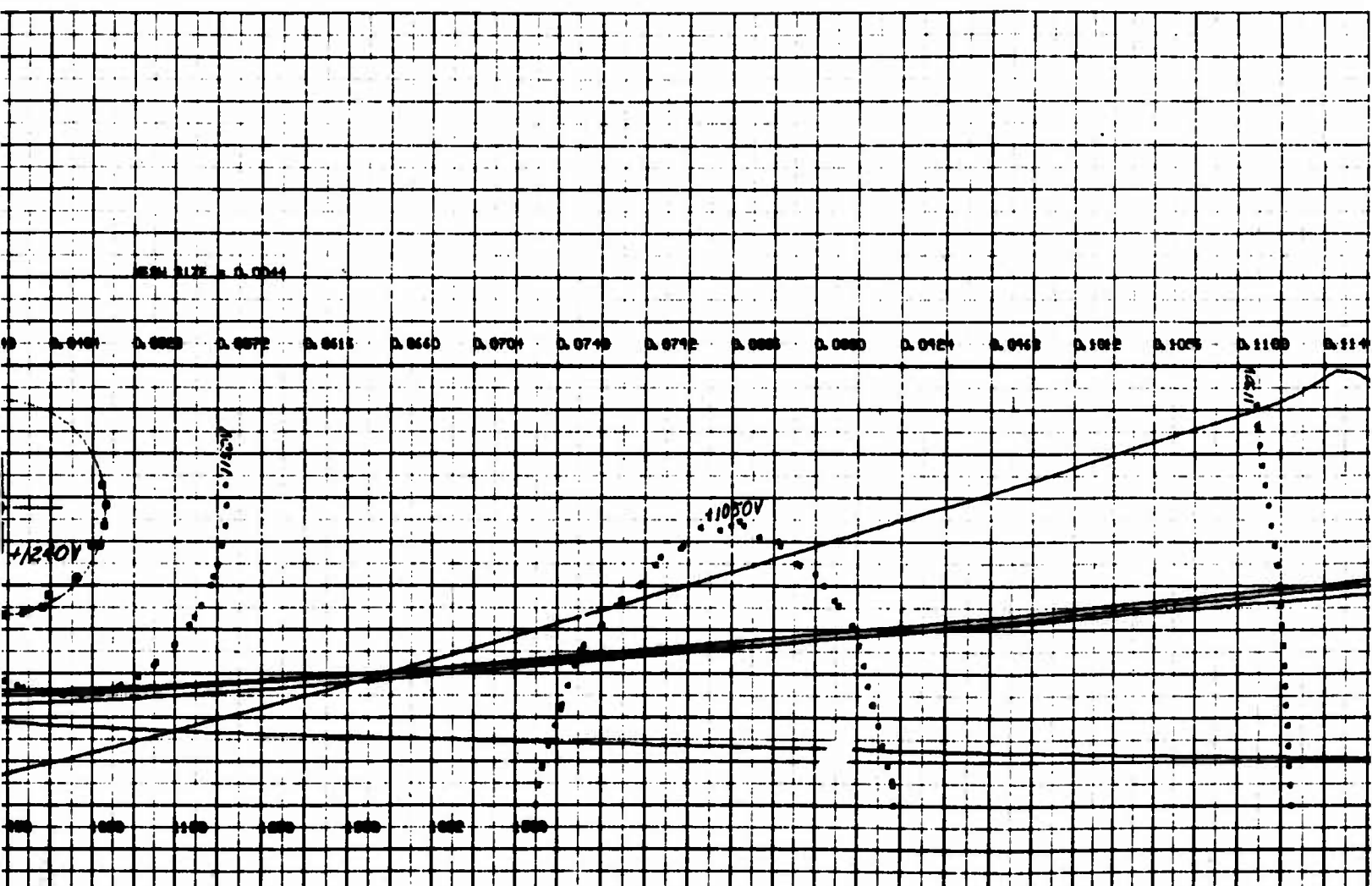
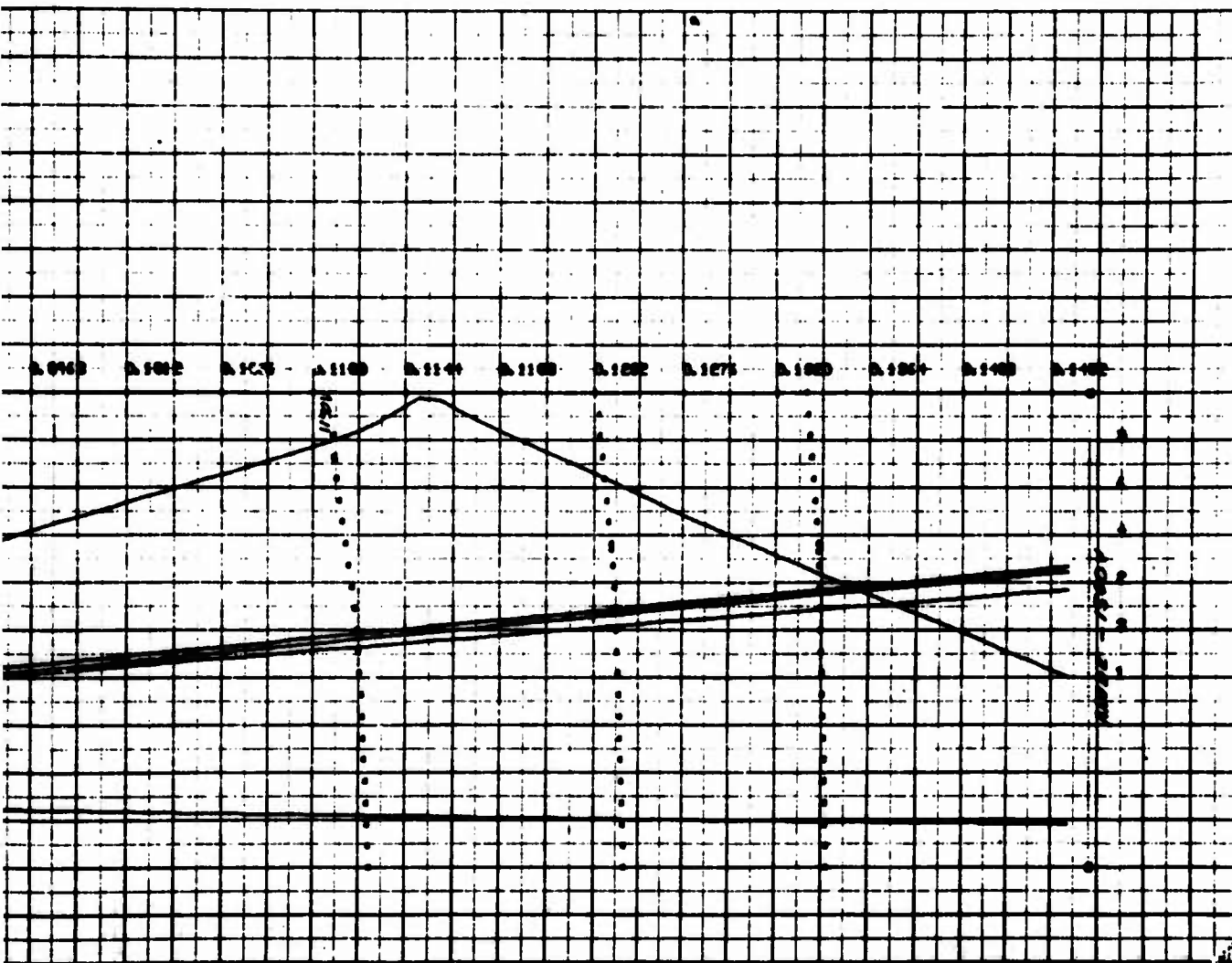

Figure 18. Electron Trajectories

C.



B.



REVISIONS BY NUMBER OF SHEETS ONLY CASE NO. 1001-0240-11 1/24/54
S. 701045-1000 VOLT CURRENT BY 20 SLOPE SPECIFIED 100 PER CENT

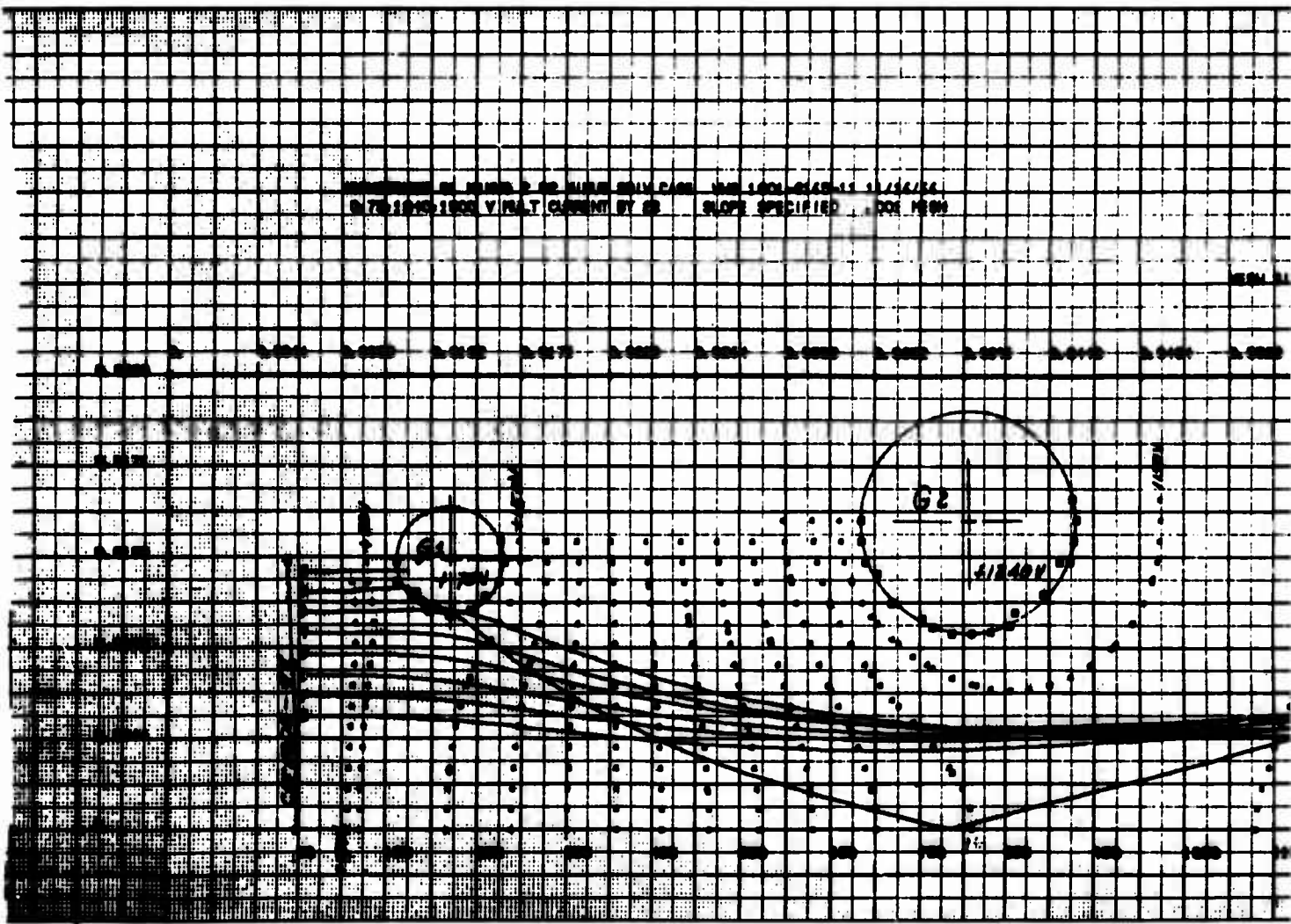

A.

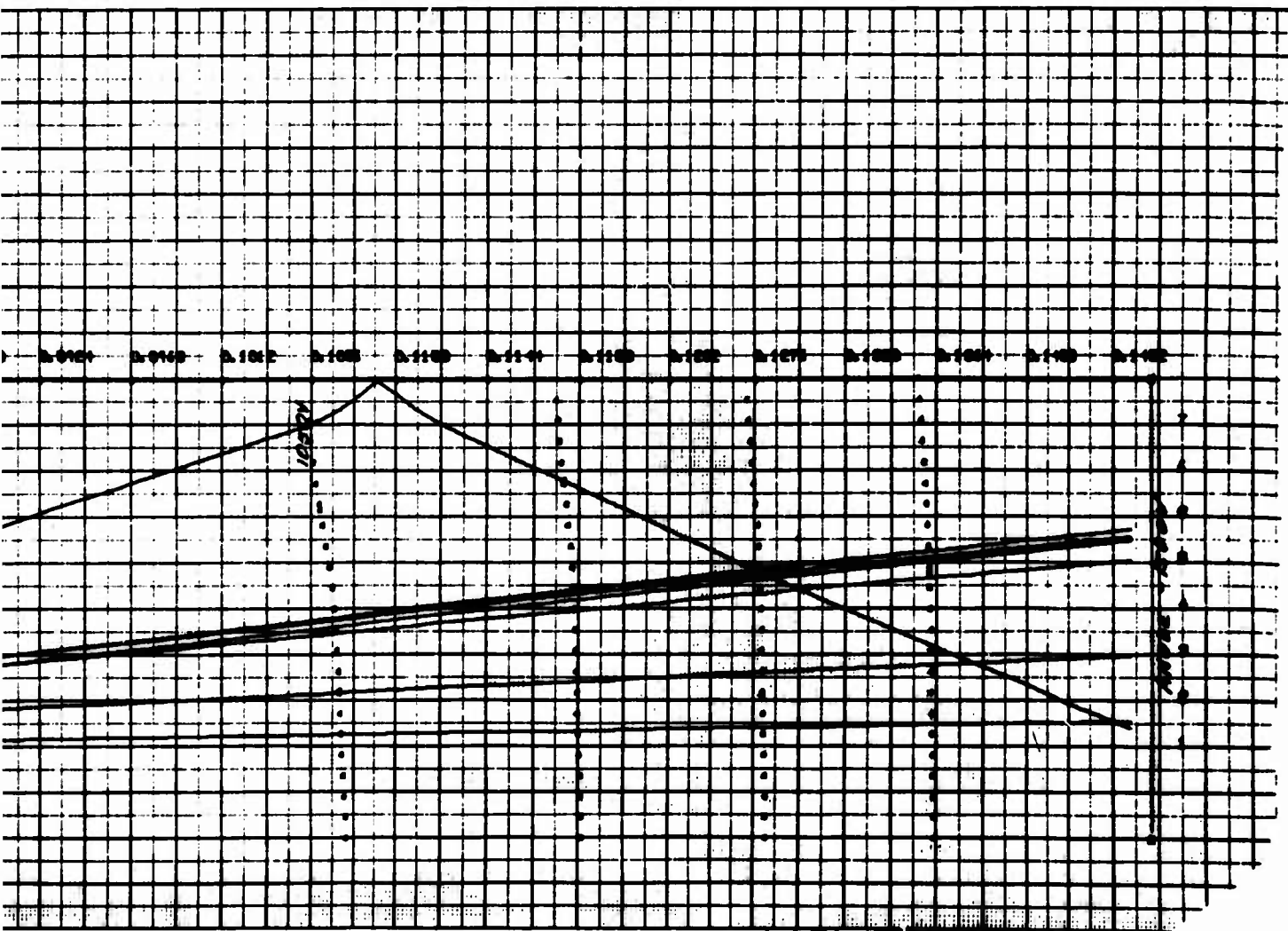

Figure 20. Electron Trajectories

C.

tube plating is the process where free hydrogen is in contact with hydrogen permeable surfaces of the tube envelope. Accelerated shelf life is accomplished by placing a tube in an air oven at 180°C ambient for five days. The rise in gas current is then recorded. To minimize this condition, tight control of plating in standard production is maintained to minimize the amount of hydrogen available during the plating process. Minimizing the time the tubes are immersed in the strike bath is absolutely necessary in order to reduce available hydrogen. The gas level of tubes that are not silver plated does not increase when the tubes are subjected to the 180°C accelerated life test. However, electrical measurements taken at high frequencies showed that the elimination of plating reduced the efficiency of the tube.

b. The Effect of a Getter on Gas in Sealed Tubes

The 4CPX250K contains two zirconium getters placed in the tube so that a maximum getter temperature range can be covered during tube operation. In order to evaluate the effectiveness of the zirconium in controlling gas levels in sealed tubes the getters were removed and accelerated shelf life tests described in the last section were run

with the following results.

<u>Construction</u>	<u>Pre-Life Icl Levels</u>	<u>Post Life Icl Levels</u>
Standard (2getters)	Less than 1 μ A	Less than 5 μ A
'Cool' getter removed	" " "	Less than 7 μ A
'Hot' getter removed	" " "	Greater than 25 μ A

'Cool' getter means 150-300°C during tube operation. 'Hot' getter is very effective in tying up diffused hydrogen and is necessary for good long life reliability. The final getter design is shown in Figure 21. The long skirt increased the amount of getter area in the low temperature range to more effectively sorb hydrogen.

c. Darkened Heaters

Increased tube life and ruggedness can be achieved by having heaters operate at lower temperatures. Tubes having high heater temperature often exhibit emissive inter-electrode leakage early in life. High heater temperatures also increase the rate of chemical reaction between the tungsten heater wire and the alumina (Al₂O₃) coating. The tungsten reduces the alumina with the release of oxygen and the volatilization of aluminum and sub oxides of tungsten. These products contribute to gas and interelectrode leakage.

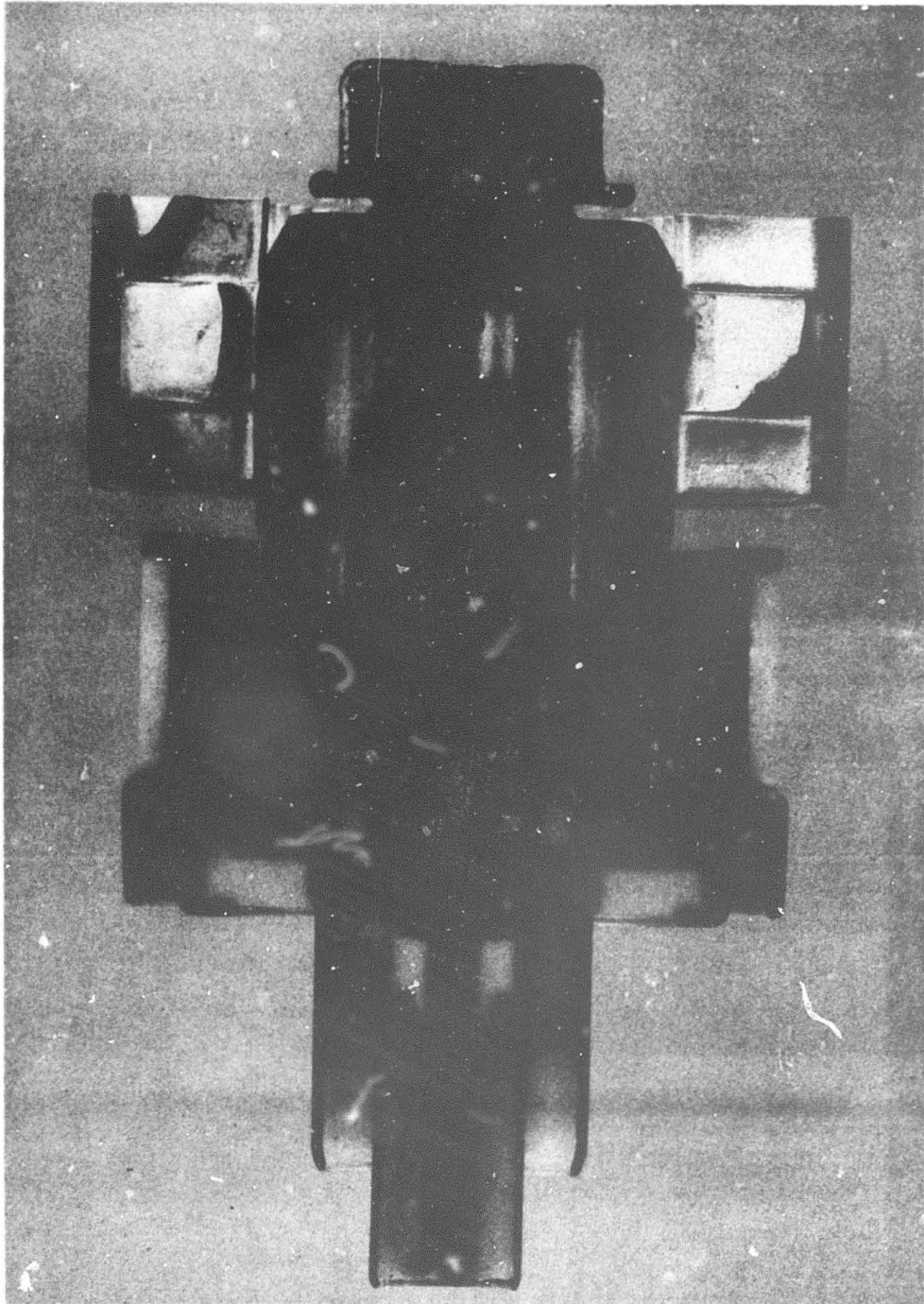

Figure 21. Final Getter Design

Volatile tungsten oxides also deposit on the internal surfaces of the emitter which increases the spectral emissivity over that of bright nickel. Hence the cathode will increase in temperature with life and the cathode usefulness will be shortened by the rapid loss of the barium oxide-strontium oxide emitter coating.

A second area in which heaters can be improved is to increase the adherence of the alumina to the tungsten heater. Under shock and vibration, the coating should not break loose to cause arcing from particles within the tube structure. If alumina is applied to a bright tungsten heater by the usual cataphoresis or spraying technique and hydrogen fired to sinter on the alumina, the bright tungsten surface under the alumina persists. The heat transfer from the bright tungsten to the alumina coating could be increased if the spectral emissivity of the tungsten is improved. Among several procedures for increasing the thermal emissivity, mechanical roughening of the surface is frequently used. One procedure for roughening a tungsten or molybdenum surface is to slightly oxidize and reduce the surface. Reduction in hydrogen does not restore the original smooth surface of the original wire after the surface is oxidized.

Alumina may be cataphorized directly on the oxidized tungsten heater and the tungsten oxide reduction will occur at the same time that the alumina is sintered on the heater. This sintering step is normally fired in hydrogen for a few minutes. The resulting heater processed in this manner will have a slight gray color and while the efficiency of heat transfer from the wire to the coating has now been increased it is possible to further improve heater radiation by darkening the alumina coating. This is accomplished by dipping the fired alumina coated heater in a solution of ammonium tungstate prepared by adding concentrated ammonium hydroxide to a suspension of tungsten trioxide in distilled water. The suspension is stirred vigorously while adding the ammonium hydroxide to just dissolve the suspended powder. A typical solution is composed of tungsten trioxide, water, and ammonium hydroxide to dissolve the tungsten trioxide. The solution does not crystallize or precipitate if kept capped to prevent loss of ammonia.

The heater is dipped in the tungstate solution at room temperature, shaken lightly to remove drops and dried in an upright position by inserting the heater legs in holes drilled in a plastic block. The heater should dry uniformly

without the presence of drops. After drying under a heat lamp or in an air oven, the heaters are fired in a molybdenum boat in a hydrogen atmosphere. When cool the heater is now ready for fabrication into tube structures.

Figure 22 shows heaters and cathodes taken from 4CPX250K's which had 500 hours of filament standby at 6.6 volts (10% above the nominal of 6.0 volts). Two of the tubes had standard production white heaters. It is of interest to note the darkening of the internal surface of the cathode from evaporation products.

The third tube had a dark cathode prepared by oxidizing the tungsten and treating the alumina with ammonium tungstate. The heater for the tube is still dark after this accelerated life. The internal surface of the cathode nickel is bright and clean and is in keeping with a cooler running heater. In developing new processing techniques it is important to avoid introducing additional elements or compounds to a tube structure for which the thermal chemical reactions cannot be substantiated by large production runs and thousands of hours of operational life. The procedure described above does not add any additional elements to that which is already well understood. For example; the tungsten heater wire is roughened by using the wire itself for the

EIMAC
4XC250K'S

ALL TUBES RUN WITH E_f ONLY FOR 500 HOURS
AT 10% ABOVE NOMINAL HEATER VOLTAGE (6.6V)



6PFL4471

STD. PROD. HDR.

TUNGSTEN COATED
WITH Al_2O_3



6PFK5644

STD. PROD. HEATER

TUNGSTEN COATED
WITH Al_2O_3



6ESK6680

DARK HEATER

(NOTE CLEAN INTERNAL
SURFACE OF CATHODE
CAN).

Figure 22. Dark Heaters

complete process. The ammonium tungstate solution impregnates the alumina coating where it decomposes to ammonia gas, water vapor and tungsten oxides as it enters the hot zone of the firing furnace. In the hydrogen hot zone the tungsten oxide is reduced to finely divided and tungsten dispersed throughout the alumina. It is this fine dispersion which increases the spectral emissivity of the alumina. Therefore, it is evident that both the white heater and the dark heater are composed of tungsten metal and alumina and no additional chemical phenomena can be expected. While the product of adding ammonium hydroxide to a tungsten trioxide suspension is described as ammonium tungstate, it has not been determined that this is the actual compound. In attempts to use chemically pure para ammonium tungstate as purchased from chemical supply houses, we have experienced difficulty in achieving a sufficiently concentrated solution to yield the desirable dark heater. There seems to be no advantage in pursuing this approach because the tungsten oxide-ammonium hydroxide technique readily produces a water white "solution" of tungsten oxide and these materials are available in any electronic laboratory.

1) Conclusion

From the foregoing results, incorporation of the dark heater was initiated. Two tubes are presently on Power Gain life test with dark heaters.

d. Ion Pump Exhausting

An ion pump station was one of the two major pieces of equipment built under this contract. It is shown in Figures 23 and 24 and is capable of exhausting up to six tubes at a time.

The station is divided into two separate vacuum systems. One system is a high vacuum system for exhausting the tubes and other system is a low vacuum system that surrounds the outside of the tubes being exhausted for corrosion protection purposes.

1) High and Low Vacuum Systems

High Vacuum System

The entire system is bakeable. All teflon and rubber derivative "O" rings as well as the oil filled mechanical roughing pump have been eliminated. All the gaskets are made of copper as are the valve seats on the bakeable valves. The plumbing that connects the components of the system together are made from 1", 1½" and 2" stainless steel tubing. The valves are capable of being baked out to

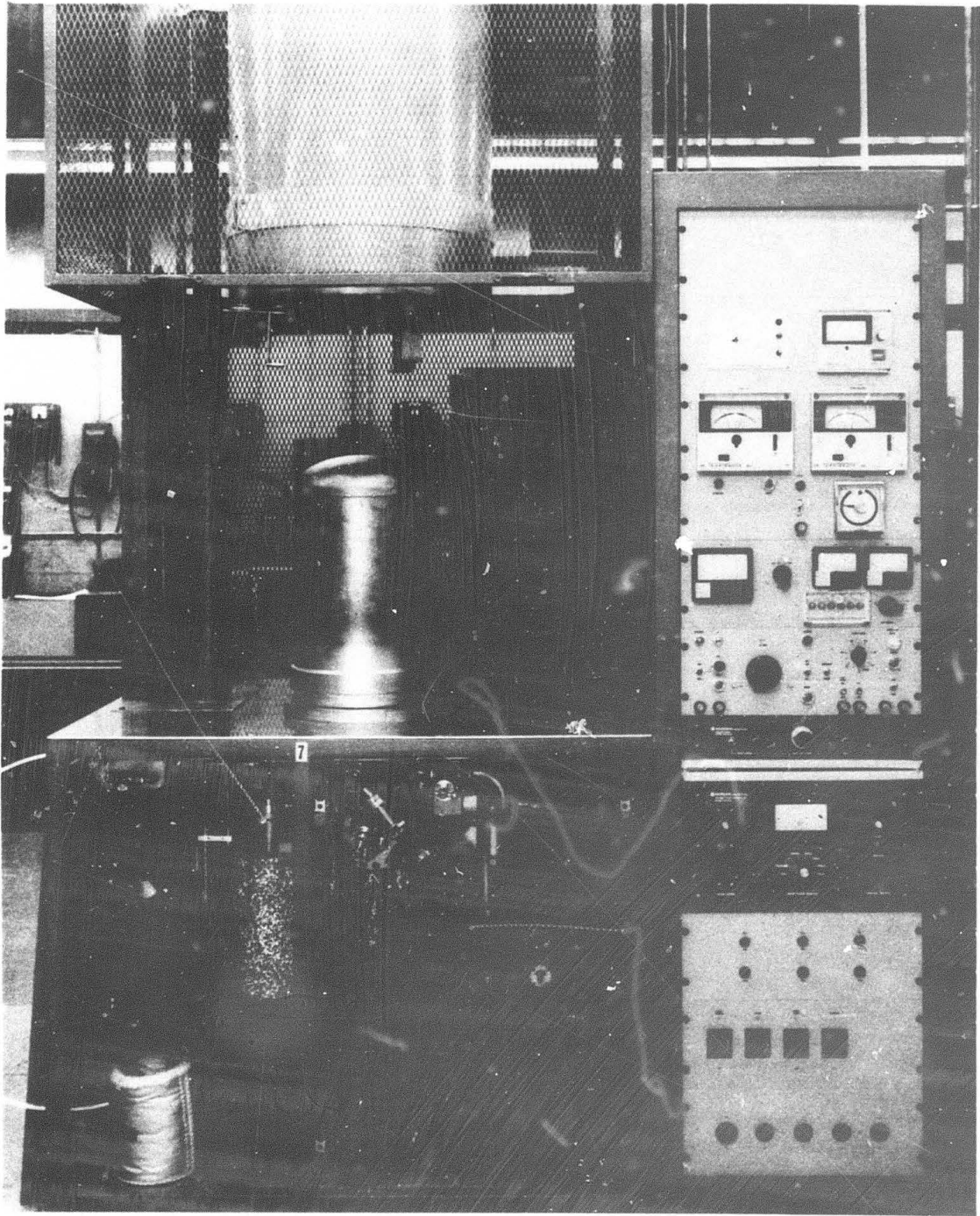

Figure 23. Ion Pump Station

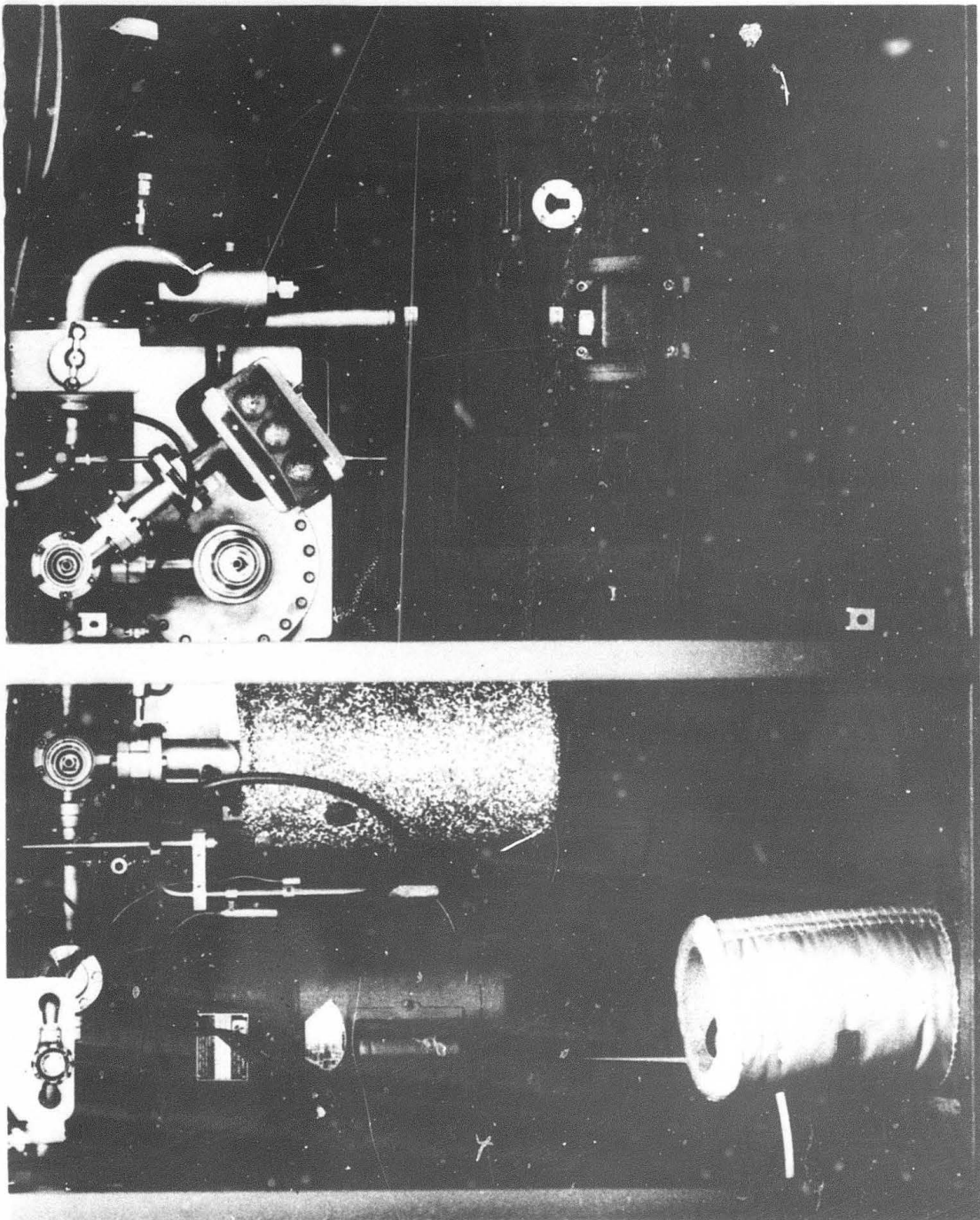

Figure 24. Ion Pump Station

500°C for several cycles.

The VacIon[®] pump is always under high vacuum and is separated from the tube exhaust manifold by a 2" bakeable valve.

The mass spectrometer preamplifier is also separated from the exhaust manifold, by a 1½" bakeable valve. Once the tubes have been placed on the manifold, a VacSorb[®] pump is used to do the initial pumping from atmospheric pressure down to approximately 1 to 10 microns before the VacIon pump is opened. The valve between the VacSorb pump and the main manifold is then closed. The VacSorb pump consists of a container filled with molecular sieve material which exhibits pumping action when immersed in liquid nitrogen.

Low Vacuum System

The low vacuum system is used to prevent oxidation of the outside surfaces of the tubes. It consists of a stainless steel bell jar and a Welch 1397B mechanical pump in series with a valve and oil vapor trap between the two. An electrically heated oven, mounted so that it can be lowered over the stainless steel bell jar, is used during bakeout.

[®]Reg. U.S. Pat. Office

2) Exhausting 4CPX250K's

Several sets of tubes were exhausted on the ion pump station. The manifold vacuum attained before nip off of the tubes is 2×10^{-9} Torr. This is two orders of magnitude better than the oil diffusion pump systems used in standard production.

During the initial ion pump run, the grid and plate supplies were not yet available; therefore, it was decided to evaluate tubes with processing limited to a 600°C bakeout followed by cathode conversion with the tubes still at 600°C temperature. The tubes were then cooled to room temperature, nipped off, aged and tested. The manifold pressure nip off was 2×10^{-9} Torr according to the vac ion pump and 1.2×10^{-8} Torr according to the mass spectrometer. Out of nine tubes pumped using the schedule described above, 3 arced in the power gain tester. The other six produced full 10KW output and two of the tubes are presently on life test. The desired bakeout temperature of 600°C was achieved in approximately one and one-half hours. The tube external vacuum maintained a steady 10 micron pressure throughout the bakeout cycle. The initial exhaust schedule, designated "A", was as follows:

1. Mount tubes on manifold.
2. Hook up filament leads.
3. Attach thermocouples to radiator jacket of one tube with moly wire.
4. Valve in VacSorb[®] pump (cryogenic) and pump tube to a pressure of less than 10 microns.
5. Place heat shields under manifold.
6. Lower external vacuum bell jar and open valve to roughing pump. Pump to 5-10 microns.
7. Raise oven temperature until tube envelope reads 600°C as measured by tube thermocouples. Hold 30 minutes.
8. Raise E_f in $\frac{1}{2}$ volt steps; one minute per step until 7.8 volts is reached. Hold for 3 minutes and reduce to 6.0 volts.
9. Close valve to VacSorb pump and open valve to VacIon[®] pump in high vacuum slowly. (Do not exceed 8×10^{-5} Torr)
10. Continue pumping until tube pressure falls below 9×10^{-8} Torr.
11. Turn off oven heat and raise oven. Turn on cooling fan.
12. When temperature is down to 200°C lower oven and set lifting clamps on external vacuum bell jar. Valve off

[®]Varian trade mark.

roughing pump and introduce N_2 into external vacuum bell jar until pressure is relieved. Valve off N_2 .

13. Raise oven and external vacuum bell jar combined.

Turn off E_f .

Several sets of six tubes each have been pumped by applying voltage to the grids and anode in addition to the filament voltages. This exhaust schedule designated "B", is as follows:

1. Mount tubes on manifold.
2. Hook up filament leads.
3. Attach thermocouples to radiator jacket of one tube with moly wire.
4. Valve in VacSorb pump (cryogenic) and pump tube to a pressure of less than 10 microns.
5. Place heat shields under manifold.
6. Lower vacuum guard and open valve to roughing pump. Pump to 5-10 microns.
7. Raise oven temperature until tube envelope reads $600^{\circ}C$ as measured by tube thermocouples. Hold 30 minutes.
8. Raise E_f in $\frac{1}{2}$ volt steps, one minute per step until 7.8 volts is reached. Hold for 3 minutes and reduce to 6.0 volts.

9. Close valve to VacSorb pump and open valve to VacIon pump in high vacuum system slowly. (Do not exceed 8×10^{-8} Torr)
10. Continue pumping until tube pressure falls below 9×10^{-8} Torr.
11. Turn off oven heat and raise oven. Turn on cooling fan.
12. When temperature is down to 200°C lower oven and set lifting clamps on vacuum guard. Valve off roughing pump and introduce N_2 into vacuum guard until pressure is relieved. Valve off N_2 .
13. Raise oven and vacuum guard combined. Turn off E_f .
14. Remove filament leads. (No.2)
15. Dress tubes with standard pump sockets using special hook up leads provided.
16. With no power applied, run a mass spectrometer chart as follows:
 - A. Run Lo scan to determine H_2 peak.
 - B. Run Hi scan to determine H_2O and CO .
17. Apply power as follows:
 - E_{c1} - 10V
 - E_{c2} - 35V
 - E_b - 550V
 - E_f - 7.0V
 - I_b - up to 1.0 amps

18. Re-run mass spectrometer charts as above.
19. Maintain power to tubes for $\frac{1}{2}$ hour shut off. At this point vacuum should be about 4×10^{-9} Torr.
20. Allow tubes to cool and pinch off. Vacuum should be 1×10^{-9} Torr at time of pinch off.

A total of 51 tubes were processed and all passed static electrical tests. When subjected to power gain testing, 7 arced out of the total of 51. This is comparable with the typical yield of 85 percent which is achieved for production tubes pumped on the standard diffusion pump system. Insufficient tubes have been pumped on schedule "A" to make a like comparison. It should be noted that it is not practical to use the vac ion vacuum system during bakeout since even a 500 liter/sec pump cannot maintain a sufficiently high vacuum to stay within its operating boundaries. This is due to the large quantity of gas liberated during the tube temperature rise between 200-400°C. Experience on other tube types indicates this gas is not associated with the use of oxide cathodes but typical of all vacuum structures. A further limitation is encountered during the conversion of oxide cathodes. The capacity of the vac sorb pump is adequate to simultaneously pump six

tubes, during bakeout and the decomposition of the carbonate to oxides.

3) Residual Gas Analysis

Two sets of six tubes were pumped with one set using pump schedule "A", and the other set using pump schedule "B". Both schedules are identical up to the point where electrode current is drawn in schedule "B". In both the exhaust schedules, the manifold nip off pressure was less than 4×10^{-9} Torr. Residual gas analysis was made using a Consolidated Electrodynamics Residual Gas Analyzer Model 21-611 shown in Figure 25. A typical plot of a gas analysis following a 600°C bakeout and the conversion of the barium strontium carbonates to their oxides per schedule "A" is shown in Figure 26. The three predominant gases indicated on the graph are hydrogen, water vapor and carbon monoxide. The source of the water vapor is believed to be from the walls of the unbaked manifold. Heating elements are being added to the manifold to correct this. The residual gas evolved during electron bombardment of the grids and anode per schedule "B" was examined. When the voltages given in schedule "B" are applied a burst of gas is given off and the total pressure rises to approximately 6×10^{-9} Torr,



Figure 25. Residual Gas Analyzer

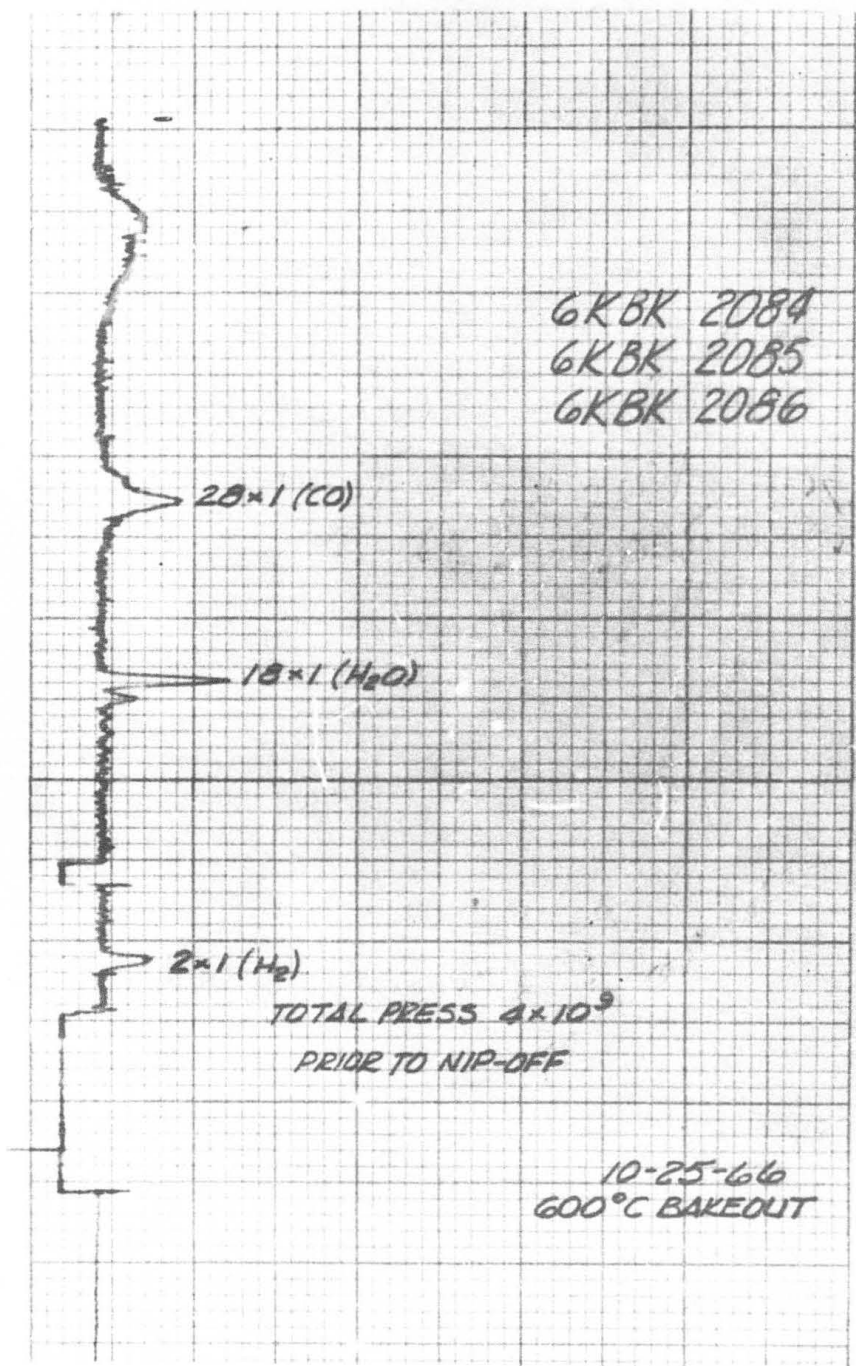

RECORDING CH

NO. 228-0012

PRINTED IN U.S.A.

Figure 26. M.S. Plot

falling back down to 1×10^{-9} Torr within a minute. Monitoring of the H₂ and CO peaks indicated that they both increase and decrease proportionally.

4) Conclusion

Tubes pumped using both schedules are now running in the power gain test gear so that long term results can be evaluated. This will be discussed more in detail under the Power Gain Testing section.

e. Dispenser Cathodes

Dispenser or impregnated tungsten cathodes have offered industry an advantage over oxide coated cathodes for many years, where high average current densities and arc resistance are required. A dispenser or impregnated cathode today is usually thought of as a porous tungsten plug, 85% dense, impregnated at high temperatures (1850°C) with barium, strontium, and sometimes calcium aluminate. The operating temperature of impregnated cathodes being evaluated is between 1000°C and 1100°C. At this temperature the tungsten reduces the aluminates chemically to barium and barium oxide which migrates to and diffuses along the surface of the cathode to provide a low work function surface for thermionic emission. If a high energy arc occurs in a tube, the porous tungsten

plug type emitter acts as a heat sink and very little, if any, of the emitting surface is destroyed. If, on the other hand, an oxide coated cathode suffered from a high energy arc discharge, catastrophic failure of the tube may occur from loss of oxide coating. It has probably been thought of and proposed many times to incorporate an impregnated type cathode in a gridded type tube; however, results to date have not been encouraging from several standpoints. In order to obtain the pulsed cathode current desired, the impregnated cathode would have to run approximately 100°C to 150°C hotter than a sprayed oxide cathode. Cathode life of the tube is usually not impaired due to the higher evaporation rate of emitting material, but reverse grid emission may become a substantial problem due to heat radiated to the control grid.

Because of the advantages that may be obtained if the known problem areas can be solved, construction of 4CPX250K tubes with tungsten impregnated cathodes was started. A cross section of the cathode assembly from the first tube built is shown in Figure 27. This tube was lost in processing. The second tube constructed achieved seven kilowatts output at a cathode temperature of approximately 1075°C. At this

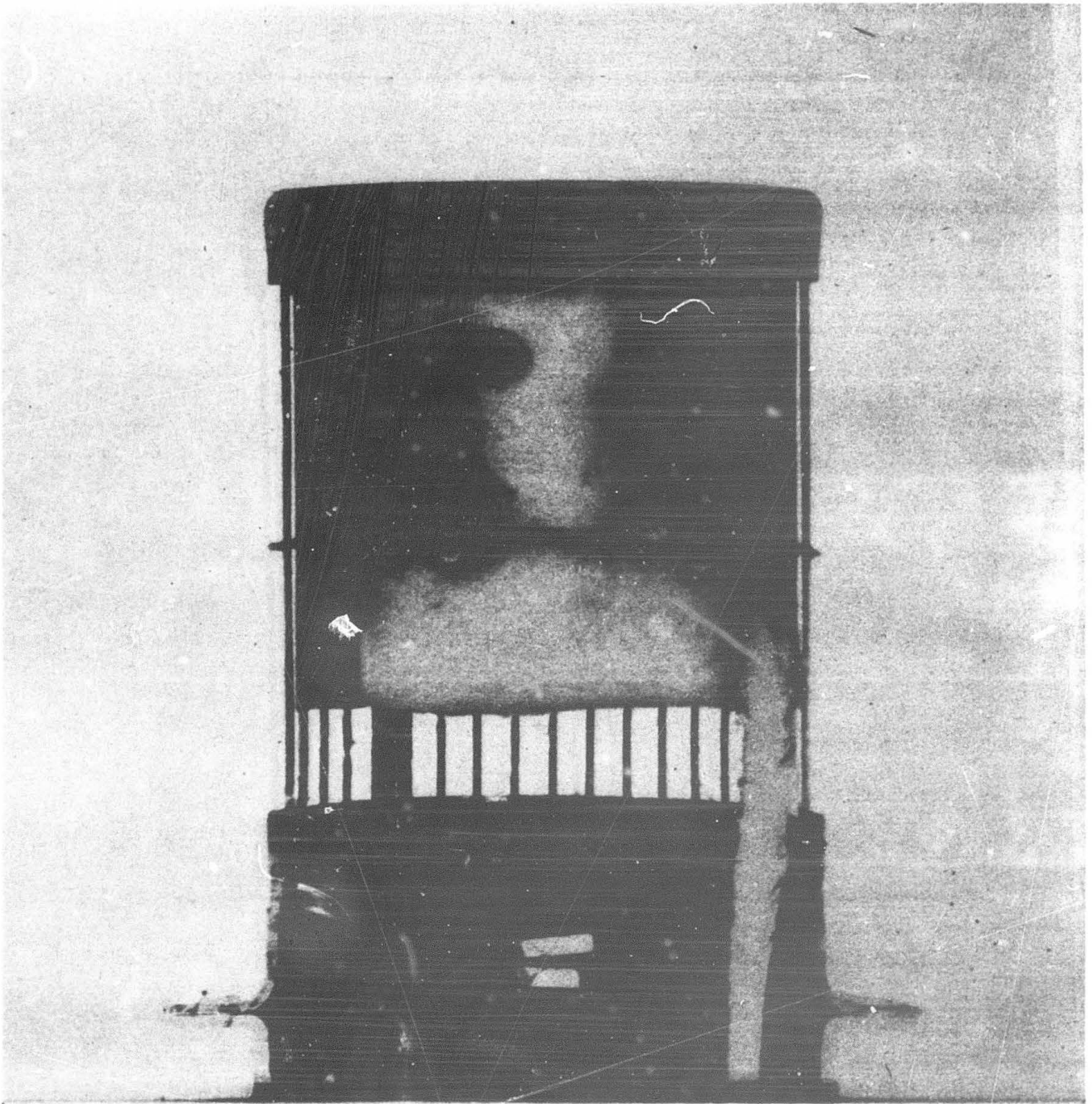

Figure 27. Cross Section of Dispenser Cathode

power level, the tube experienced several arcs. It was dissected for examination. No deterioration of the cathode was observed. The reason for the arcs may have been due to the aging being inadequate. Some cathode poisoning during operation is also suspected. The control grid was gold plated moly and the gold from the top half of the control grid had evaporated due to the higher cathode operating temperature. Heat conducted away from the bottom of the control grid probably kept the gold from the bottom half of the grid from evaporating.

Other problems in evaluating the dispenser cathodes were encountered in that the operating temperature was too low for the required emission with a filament voltage of 6.0 volts with the initial bonded heater design. At 6.0 volts the cathode temperature was approximately 970°BT . In order to obtain static electrical characteristics comparable to the oxide coated cathode, it was found that a cathode temperature of greater than 1020°CBT was necessary. Therefore more cathodes with bonded heaters were ordered so that a temperature of approximately 1020°CBT would be obtained at a filament voltage of 6.0 volts.

High temperature grids were also used in conjunction with

the next generation of dispenser cathodes.

Titanium coated molybdenum, tungsten carbide coated molybdenum and carburized molybdenum grids were made for use with the dispenser cathodes. Titanium coated grids were evaluated with dispenser cathodes operating at 1020°C.

Although the primary grid emission is not as low as is the case with gold plated molybdenum, it is well within the upper test limit of 100 micro amperes. Four more 4CPX250K's were made with dispenser cathodes having an operating temperature of 1020°C_BT at 6.0 volts filament voltage.

Two tubes had titanium coated control grids and the other two had tungsten carbide coated control grids. The tubes were pumped and aged. Again the tubes were low on emission.

The two tubes with titanium control grids were put in the power gain tester and the filament voltage was increased to 6.5 volts. This corresponded to a cathode temperature of 1040°C_BT. The tubes produced 10 kilowatts and 8 kilowatts output respectively. After 100 hours of operation, the output had dropped to 6 and 4 kilowatts respectively and were removed for continuous arcing. The tubes were opened and examined visually. Only a very few faint arc

marks could be found on the cathode. The other parts of the tube appeared normal.

1) Conclusion

The use of dispenser cathodes for this application did not appear to be at all promising; however, there were indications that titanium coated or tungsten carbide coated control grids could be used in conjunction with dispenser cathodes. Since by this point in time the sprayed and machined cathodes were doing well on life test in the power gain test equipment, future work on this portion of the program was terminated.

8. Evaluation Test Program to Test the Effects of Improvements

a. Power Gain Testing

The Power Gain Test Equipment shown in Figure 28 was completed and is operational. Ten tubes can simultaneously be operated at full power. A block diagram of the tester is shown in Figure 29. The equipment is composed of standard commercial equipment housed in standard relay rack cabinets. The system consists of three basic modules. An oscillator-intermediate power amplifier (IPA) and tube under test (TUT) driver module; a control module; and a TUT module.

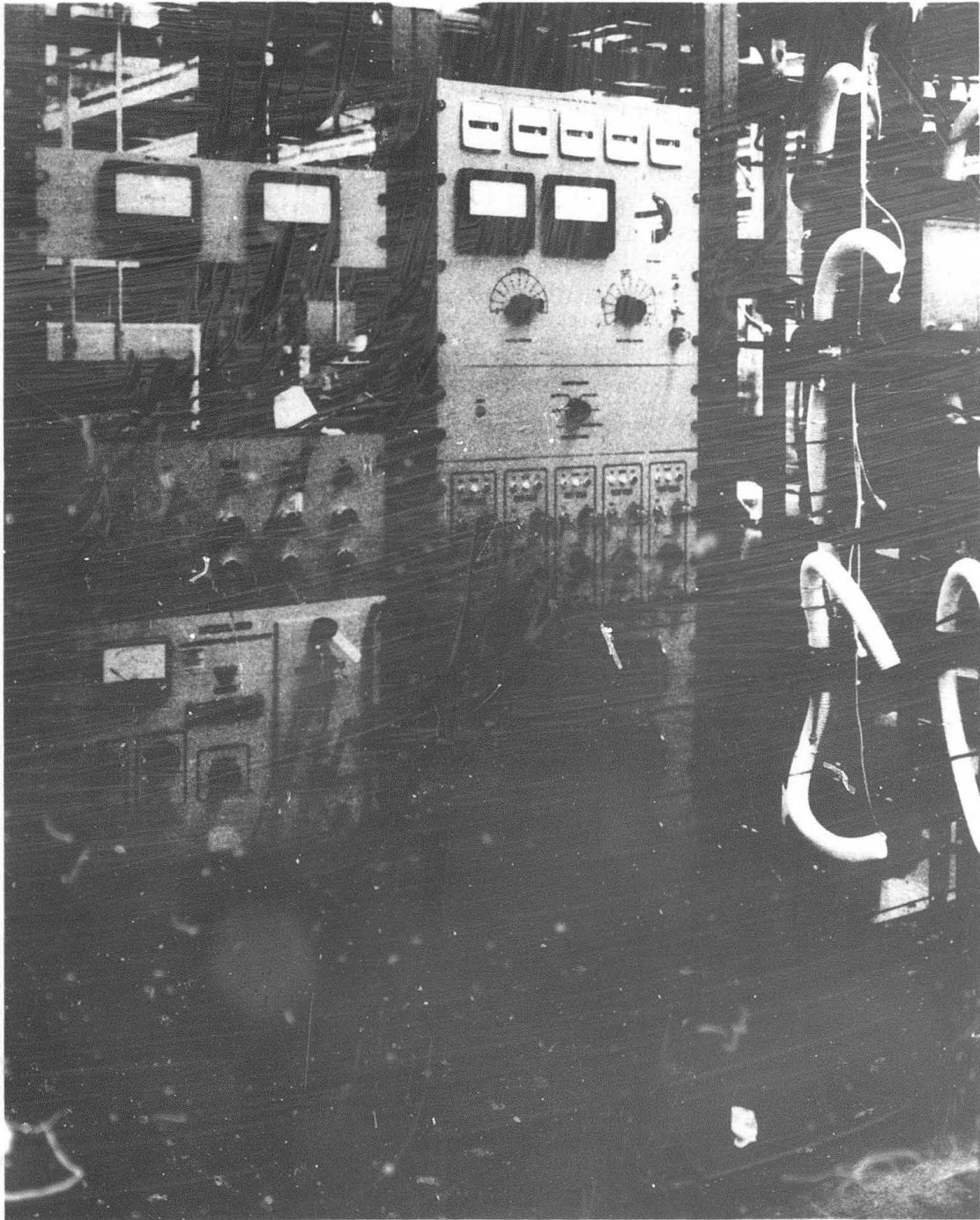

Figure 28. Power Gain Tester

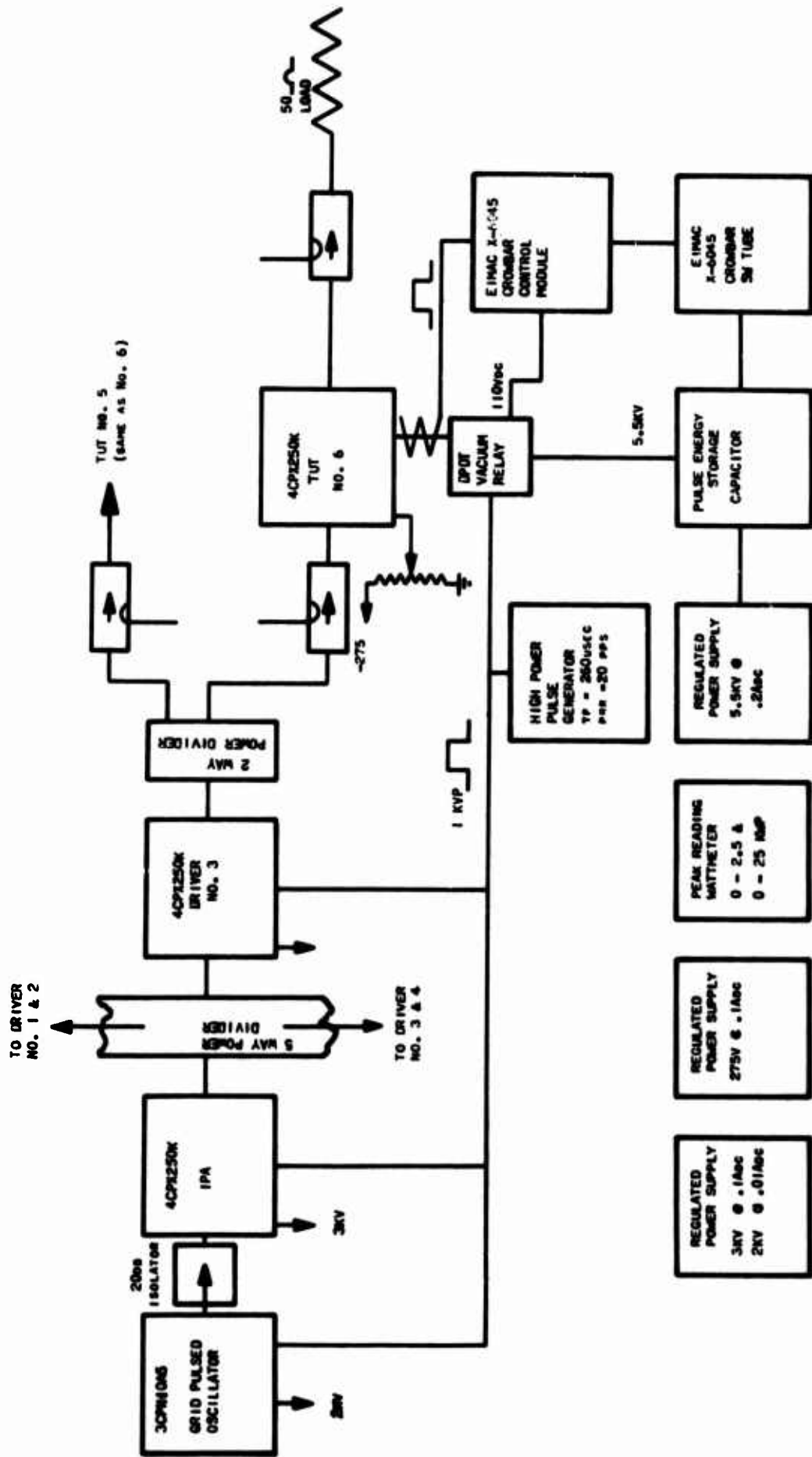

Figure 29. Block Diagram of Power Gain Tester

1) Oscillator, IPA & TUT Driver Module.

This unit provides the pulsed 442MHz rf drive for all 10 TUT's and consists of the following items:

1 ea.) 442MHz grid pulse modulated cavity oscillator consisting of a cavity oscillator using an EIMAC 3CPN10A5.

6 ea.) 442MHz grounded grid amplifiers, Bendix Radio PN 2019230-0501.

1 ea.) 6.0Vac @ 20A filament supply.

2 ea.) Ferrite Isolators.

1 ea.) Five (5) way power divider.

2) Control Module

This unit controls, and monitors equipment operation, and contains the following items:

1 ea.) Metering panel with E_f , E_{c1} , E_{c2} , and E_{tb} meter for the TUT's.

1 ea.) Peak rf power monitoring panel from Bird Electronics.

5 ea.) Filament supplies for TUT's. Each with its own off-on, adjust, and overcurrent protection, and rated for 0-7.5 Vac @ 5A.

1 ea.) High Power Pulse Generator, Velonex model 350 (special) (TUT & driver E_{c2})

1 ea.) Regulated power supply, 0.5 to 6.5KVdc @ .2A,

Northeast Scientific model #RE-6520. (TUT Ebb)

1 ea.) Regulated power supply, 250 to 275Vdc @ .1A, Techni-power model M-265.0-0.100 (Ecl)

6 ea.) Running time meter. 0-9,999.9 hours.

1 ea.) Control panel with required controls.

3) TUT Module

This unit contains the 10 TUT amplifiers, Bendix Radio PN 2019230-0501, and 5 each EIMAC X-6045 Electronic Crowbars with special logic plug-ins. Monitoring of ic2, & ik for TUT's 3 & 8 is accomplished through the use of Pearson model 411 current transformers, and an external oscilloscope. Fault sensing for the X-6045 Crowbars is accomplished by current sensing toroids. Five (5) Vacuum Relays are provided to isolate a pair of TUT's if one of the two arcs during operation. These relays are controlled by the interlock contacts supplied in the X-6045 Crowbar. The electronic crowbars have an arc counting mechanism built into them so that monitoring the number of arcs for a specified time is an easy matter.

4) Operational Testing

Ten tubes were put on test that consisted of four variables shown in Table IV.

<u>Socket No.</u>	<u>Tube No.</u>	<u>Hrs. Running Time</u>	<u>Ecl</u>	<u>Po</u>	<u>Remarks</u>
1	6KBK 2092	0	115	10.5KW	600°C Bakeout-Pumped per schedule A
2	6KBK 2093	0	105	10.5	600°C Bakeout-Pumped per schedule A
3	6KKK 5739	0	100	11.0	Present production tube
4	6KKK 5740	0	110	11.0	Present production tube
5	6KKK 5741	0	100	10.0	Present production tube
6	6KKK 5742	0	100	10.5	Present production tube
7	6CKK 7512	0	100	10.0	Tape film cathodes
8	6CKK 7507	0	100	10.0	Tape film cathodes
9	6KCK 4395	0	100	10.5	Extended interface cathodes
10	6KCK 4396	0	100	10.5	Extended interface cathodes

TABLE IV

The prime objective of this program was to be able to produce a 4CPX250K tube type that will operate for a minimum of 4000 hours with a maximum of 10 arcs. In order to obtain some confirmation of this performance capability a statistical test program was established. If one assumes that the arc rate is constant throughout the 4000 hours of useful operation,

the maximum allowable arc rate would be .0025 arcs/hour. The confidence level obtained during a life test, based on a constant linear arc rate, would be 1.0 minus the probability of obtaining the number of arcs encountered from a tube or tubes with a real arc rate of .0025 arcs/hour when the tube or tubes arc at random.¹

Table V gives the amount of time required by a tube or tubes to achieve a 60% confidence level that the tubes will produce 4000 hours of life with no more than 10 arcs.

4CPX250K Life Test

T = 4000 hours with no more than 10 arcs.
Arc rate = .0025 arcs/hour maximum.

Number of Arcs Encountered During Test Period	Confidence Level	
	60% Test-Hours Required	99% Test-Hours Required
0	372	1840
1	825	2680
2	1230	3360
3	1680	4000
4	2120	4650
5	2510	5240
6	2950	5800
7	3400	6400
8	3760	6920
9	4200	7500
10	4600	8100

TABLE V

¹B. Epstein and M. Sobel, "Life Testing", Journal of American Statistics Association, Volume 48 (1953) pp. 486-502.

At this time, eight of the ten tubes have over 2000 hours of operation. Historically, transmitting tubes have not been known to arc at a linear rate. However, it was not felt it was necessary to generate a statistical model based on non-linear arc rates since life test will be performed at the site utilizing tubes shipped against this contract.

b. Life Test and Arcing Results

At this time, eight of the ten tubes have over 2000 hours running time per tube. The two tubes with film or tape cathodes were removed after 1450 hours running time for low power output and continuous arcing. This was discussed earlier in the cathode section of the report. Table VI summarizes the status of the ten tubes now under test. Two arcing situations have been encountered. Those arcs that take place during life under field power output conditions and arcs that occur in turning the equipment on after a shutdown. The first shutdown of the equipment was made at approximately 1450 hours of life to remove the film cathodes. During that time a total of six arcs occurred, three to the film cathodes, 2 to the extended interface cathodes and one to the Bf pumped only cathodes. This data is summarized in Table VII. The two film cathode

4CPX250K LIFE TEST

<u>Socket No.</u>	<u>TUT NO.</u>	<u>Ecl</u>	<u>PO</u>	<u>Time Meter</u>	<u>Hours</u>	<u>Arcs in service</u>	<u>Remarks</u>
1	6K BK 2092	105	10.5KW	2313	2156	1	600°C Bakeout - Pumped per schedule A
2	6K BK 2093	110	10.5	2313	2156		600°C Bakeout - Pumped per schedule A
3	6K KK 5739	105	11.0	2377	2182		Present production tube
4	6K KK 5740	105	11.0	2377	2182		Present production tube
5	6K KK 5741	105	10.0	2376	2183		Present production tube
6	6K KK 5742	105	10.5	2376	2183		Present production tube
7	7A NK 1968	105	10.0	2116	509		Standard pumped dark heaters
8	7A NK 1969	105	10.0	2116	509		Standard pumped dark heaters
9	6K CK 4395	105	10.5	2287	2094	1	Extended interface cathodes
10	6K CK 4396	105	10.5	2287	2094	1	Extended interface cathodes

TABLE VI

4CPX250K LIFE TEST

<u>TUT No.</u>	<u>Arcs In Service</u>	<u>Arcs During Shutdown & Start up</u>	<u>Remarks</u>
1 6KBK 2092	1	0	Still in service after 2000hrs.
2 6KBK 2093	0	0	Still in service after 2000hrs.
3 6KCK 5739	0	1	Still in service after 2000hrs.
4 6KCK 5740	0	0	Still in service after 2000hrs.
5 6KCK 5741	0	1	Still in service after 2000hrs.
6 6KCK 5742	0	0	Still in service after 2000hrs.
7 7AMK 1968	0	1	Still in service after 500hrs.
8 7AMK 1969	0	0	Still in service after 500hrs.
9 6KCK 4395	1	0	Still in service after 2000hrs.
10 6KCK 4396	1	1	Still in service after 2000hrs.
<hr/>			
6CCK 7512	2*		Removed after 1450 hrs.
6CCK 7507	1*		Removed after 1450 hrs.

* Arcing continuous after 1450 hrs.

TABLE VII

tubes were removed and replaced with two tubes with dispenser cathodes in sockets 7 and 8. The tubes with dispenser cathodes ran for approximately 70 hours before the power output dropped to below 5KW. At the same time continuous arcing took place with these two tubes. The tubes were removed and were replaced with two standard tubes with dark heaters. When the equipment was put back on the air, No. 3 tube (standard) arced once.

When eight of the ten tubes reached 2000 hours they were removed and given static electrical tests. When the tubes were reinstalled and put back on the air in the power gain test equipment, tubes Nos. 5, 7, and 10 arced once. Since that time no arcs have been recorded.

Referring to Table VII it can be seen that so far the tubes on power gain life test are operating well within the minimum requirements of 10 arcs during 4000 hours of operation at 10 kilowatts.

c. Life Testing With Regard to Sublimation of Cathode Material

When the two tubes with film cathodes failed on life test, a deposit of nickel was seen by visual examination on the inside surface of the anode. It was assumed that the source of the deposit was the cathode cans. This led to

another assumption that the cathode was running too hot. A test vehicle was made and shown in Figure 30. A temperature profile was taken using an optical pyrometer. The results shown in Figure 31 indicate that the cathode is not operating too hot; however other heating effects take place at the operating frequency to increase the temperature significantly. Also since the coatings on the film cathodes were thin, this could also be an explanation for a higher than normal cathode temperature resulting in a coating of sublimed nickel on the anode. The effort in this area is still being monitored.

d. Arc Protection

During the course of life testing, the question came up with regard to simulation of conditions of testing at EIMAC vs actual on site conditions. The only area of concern uncovered was the use of fuses at the site for arc protection vs the use of the EIMAC X-6045 Crowbar used at EIMAC.

Tests were performed under conditions shown in Figure 32. The results of the test indicated that the Bendix fuses provide better arc protection to the tube than the EIMAC X-6045 Crowbar in the power gain test equipment.



Figure 30. Temperature Measuring Vehicle

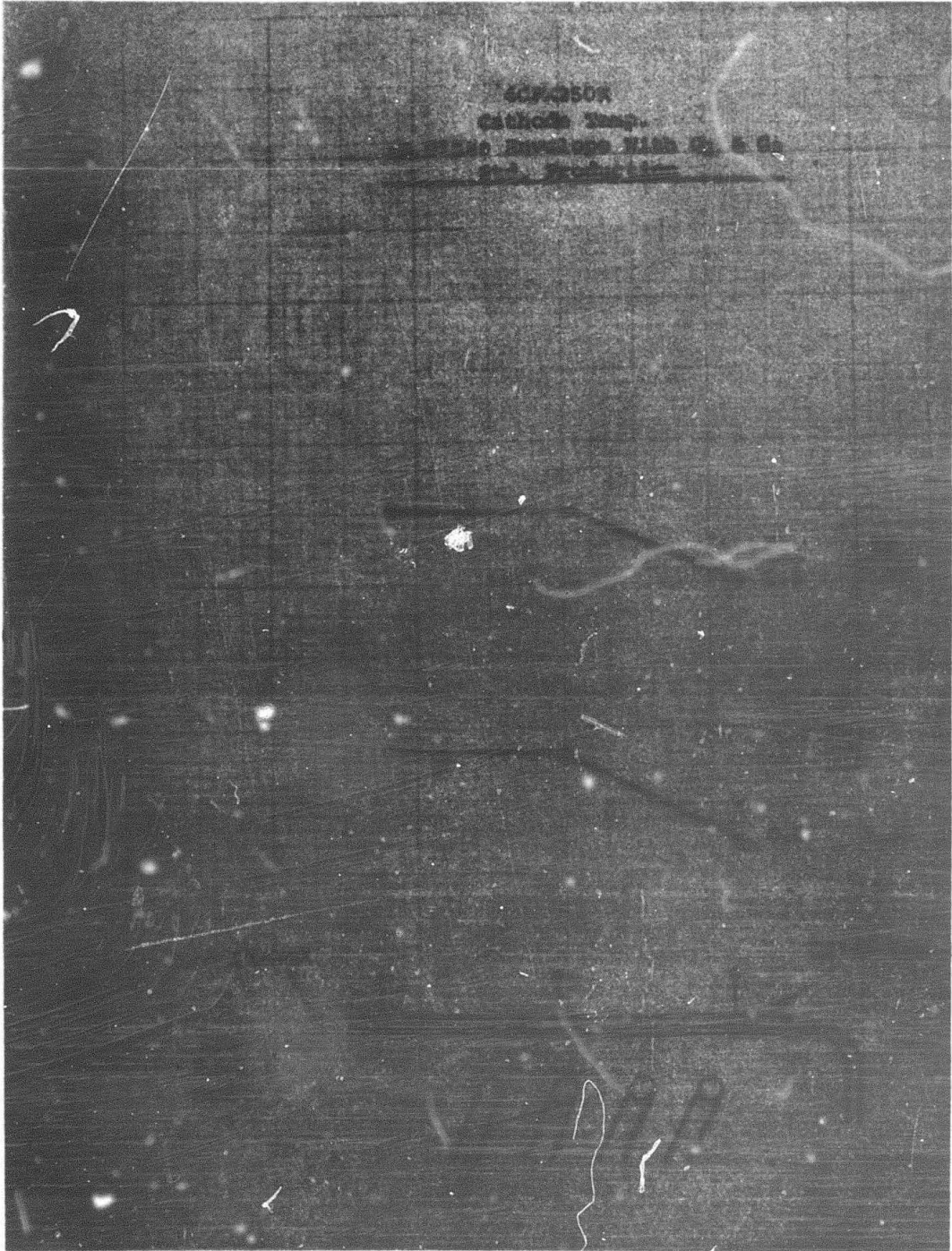

Figure 31. Temperature Profile

Characteristics of Bendix High Voltage Fuses

Bendix Part No.----- 1106-0501

Type ----- Cartridge, 1 3/4"L X 13/32" Dia.

Cost ----- \$.28 each in quantities over 200

DC Current Rating ----- 1.0 Amp nominal

DC Resistance ----- 2.4 ohms nominal

DC Voltage Rating ----- 7.5KV (estimated)

*Energy Rating ----- 0.5 joules nominal

**Clearing time @ 400 amps ----- 6.0 μ secs nominal

* Energy rating established by testing fuse in circuit shown in Fig. I attached. Stored energy in capacitor "C" increased until fuse blew. Test repeated several times, and results averaged.

** Clearing time established by testing fuse in circuit shown in Fig. II attached. Test conditions were:

E = 5000Vdc

R1 = 36K ohm

R2 = 10 ohm

C1 = 3 ufd

Energy in C1 = 37.5 joules

V1 = EIMAC X6045 switch tube module

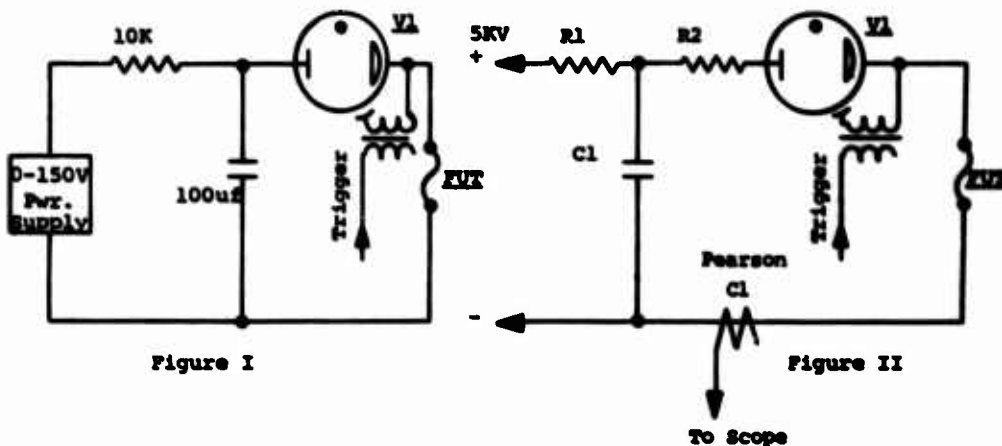

Figure 32. Crowbar vs Fuse Circuitry

The reason the fuses provide better protection is because the time constant of the energy storage capacitor and the crowbar switch tubes current limiting resistor (2 ohms) is greater than the clearing time of the Bendix fuse (8 microseconds). The crowbars could be adjusted to provide better protection, but this was not done since the difference would not be seen by the arcing tube.

9. Delivery of Tubes

During the course of this contract 100 tubes were delivered at a rate of 20 tubes per month over a five month period.

IV. CONCLUSIONS

Eight tubes operating in a mode similar to Radar Set AN/FPS-85 have successfully completed over 2000 hours of operation. Four of the tubes are regarded as present standard EIMAC production. Two other tubes were processed at exhaust using a high temperature bakeout of 600°C. The emission carbonates were converted and the tubes were nipped off. No electron current was drawn on the pump. The last two tubes were fabricated and processed standard, but had extended interface cathodes. Time is still being accumulated on these tubes toward a goal of over 4000 hours per tube.

The mechanical design was improved by:

1. Changing the stem assembly design to afford stronger ceramic-metal seal joints and allow for easier alignment when mounting the cathode and grids.
2. Changing the center rod material from alloy 46 to P-51 nickel to allow greater mechanical flexibility.
3. Incorporation of a step in the ceramic cylinder that is brazed to the screen grid shell to minimize arcing.

The cathode system chosen in the final design was a double carbonate spray mix with an n-butyl methacrylate binder that was oversprayed in thickness and machined back to

size.

Film or tape cathodes and dispenser cathodes with bonded heaters offered no advantage for this application.

The computer analysis pointed out that tight control of cathode and grid spacings is necessary to minimize arcing. Between the maximum and minimum mechanical tolerances on the grids, the cathode current density can double at certain points on the surface. Inspection procedures which result in arc-free yield of greater than 90 percent were established.

The use of dark heaters lowers the heater temperature by $100^{\circ}\text{C}_{\text{BT}}$ for the same number of watts input and the same cathode life, thus extending heater life.

Standard EIMAC production tubes can be made on both ion or dry pump systems as well as oil diffusion pump systems. No apparent electrical or life differences have been noticed; however the pressure at nip off was approximately two orders of magnitude lower (2.0×10^{-9} Torr) for the ion or dry pumped tubes. It was also found that good tubes can be made by using a high temperature bakeout and by not drawing electrode current on the pump after cathode conversion.

The above improvements have been implemented into the standard EIMAC production 4CPX250K tube type.

RECOMMENDATIONS

From the results obtained during the course of this program the following recommendations are made.

1. Maintain the improvements outlined in the conclusion of this program as part of the standard EIMAC 4CPX250K production procedures.
2. Continue life testing the tubes, presently under test, to destruction, i.e. 10 arcs within 4000 hours or loss of power output to below 5 kilowatts.
3. Following the completion of life test, analyze the data to determine if further work is necessary. The tubes should also be analyzed to determine the mode of failure and so that final recommendations can be made.

UNCLASSIFIED

Security Classification

DOCUMENT CONTROL DATA - R & D		
<i>(Security classification of title, body of abstract and indexing annotation must be entered when the overall report is classified)</i>		
1. ORIGINATING ACTIVITY (Corporate author) EIMAC, Division of Varian Associates		2a. REPORT SECURITY CLASSIFICATION Unclassified
		2b. GROUP
3. REPORT TITLE FPS-85 Tube Improvement Program 4CPX250K		
4. DESCRIPTIVE NOTES (Type of report and inclusive dates) Final Report, 1 Mar 66 - 1 Mar 67		
5. AUTHOR(S) (First name, middle initial, last name) Maurice L. Mullin Robert D. Culbertson		
6. REPORT DATE September 1967	7a. TOTAL NO. OF PAGES 120	7b. NO. OF REFS 1
8a. CONTRACT OR GRANT NO. AF30(602)-4038	9a. ORIGINATOR'S REPORT NUMBER(S) TR-67-4	
8b. PROJECT NO. System 496L	9b. OTHER REPORT NO(S) (Any other numbers that may be assigned this report) RADC-TR-67-153	
10. DISTRIBUTION STATEMENT This document is subject to special export controls and each transmittal to foreign governments, foreign nationals or representatives thereto may be made only with prior approval of RADC (ENLI), GAFB, N.Y. 13440.		
11. SUPPLEMENTARY NOTES Merton C. Kraft EMATP/ AC 315 330-4847		12. SPONSORING MILITARY ACTIVITY Rome Air Development Center (EMATP) Griffiss Air Force Base, New York 13440
13. ABSTRACT <p>A production refinement program for improving the performance, reliability and life of the tube type 4CPX250K was conducted. The objective set for this program was to be able to produce a tube that would operate in the radar set AN/FPS-85 for a minimum of 4000 hours with a maximum of 10 arcs, and a power decrease of not more than 3db during that time.</p> <p>The investigation included mechanical and electrical aspects, as well as a cathode investigation, and a computer analysis of cathode current density as a function of the electrode alignment.</p> <p>Processing procedures and exhaust schedules were also investigated.</p> <p>As a result of this contract eight tubes in the power-gain test equipment have been operating over 2000 hours satisfactorily.</p> <p>Conclusions regarding methods of improving the 4CPX250K are made. These improvements have been implemented into the Eimac tube design. Recommendations for further action are made.</p> <p>(1) ↑</p>		

DD FORM 1473
1 NOV 65

UNCLASSIFIED

Security Classification

UNCLASSIFIED

Security Classification

10. KEY WORDS	LINK A		LINK B		LINK C	
	ROLE	WT	ROLE	WT	ROLE	WT
Negative Grid Tetrode High Vacuum Electron Tubes						

UNCLASSIFIED

Security Classification