

UNCLASSIFIED

AD NUMBER

AD830276

LIMITATION CHANGES

TO:

Approved for public release; distribution is unlimited.

FROM:

Distribution authorized to U.S. Gov't. agencies and their contractors;
Administrative/Operational Use; MAR 1964. Other requests shall be referred to Army Materiel Command, Alexandria, VA.

AUTHORITY

USAMC ltr, 22 Jul 1971

THIS PAGE IS UNCLASSIFIED

WICOM 111111
BDDO 507
RM C-147

AMC PAMPHLET

AMCP 706-340

RESEARCH AND DEVELOPMENT OF MATERIEL

ENGINEERING DESIGN HANDBOOK

CARRIAGES AND MOUNTS SERIES

CARRIAGES AND MOUNTS—GENERAL



PROPERTY OF THE U.S. ARMY
REDSTONE SCIENTIFIC INFORMATION CENTER
REDSTONE ARSENAL, ALABAMA

REDSTONE SCIENTIFIC INFORMATION CENTER



5 0510 00197108 1

HEADQUARTERS
UNITED STATES ARMY MATERIEL COMMAND
WASHINGTON 25, D. C.

31 March 1964

AMCP 706-340, Carriages and Mounts--General, forming part of the Carriages and Mounts Series of the Army Materiel Command Engineering Design Handbook Series, is published for the information and guidance of all concerned.

(AMCRD)

FOR THE COMMANDER:

OFFICIAL :

SELWYN D. SMITH, JR.
Major General, USA
Chief of Staff

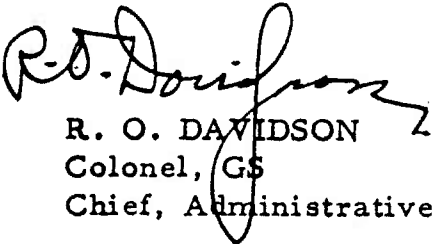
R. O. DAVIDSON
Colonel, GS
Chief, Administrative Office

DISTRIBUTION: Special

PREFACE

This Handbook has been prepared as one of a series on Carriages and Mounts and forms part of the Engineering Design Handbook Series of the Army Materiel Command. This handbook presents introductory information and preliminary design procedures for the structures and mechanisms that are embodied in a gun carriage or mount. More detailed design information concerning these items will be found in other handbooks of the series, published or to be published.

Material for this handbook was prepared by The Franklin Institute for the Engineering Handbook Office of Duke University, prime contractor to the Army Research Office—Durham. The Carriages and Mounts Series was under the technical guidance and coordination of a special committee with representation from Rock Island Arsenal and Springfield Armory, of the Weapons Command ; Development and Proof Services of the Test and Evaluation Command ; Army Tank-Automotive Center of the Mobility Command ; Frankford Arsenal of the Munitions Command ; and Watertown Arsenal of the Missile Command. Chairman was Mr. K. A. Herbst of Headquarters, Weapons Command.

Agencies of the Department of Defense, having need for Handbooks, may submit requisitions or official requests directly to Publications and Reproduction Agency, Letterkenny Army Depot, Chambersburg, Pennsylvania 17201. Contractors should submit such requisitions or requests to their contracting officers.

Comments and suggestions on this handbook are welcome and should be addressed to Army Research Office—Durham, Box CM, Duke Station, Durham, North Carolina 27706.

TABLE OF CONTENTS

	<i>Page</i>
PREFACE	i
LIST OF ILLUSTRATIONS	iv
LIST OF SYMBOLS	v
CHAPTER 1. INTRODIJCTION	1
A. Purpose	1
B. Definition	1
C. Function	1
CHAPTER 2. DISTINCTION' BETWEEN CARRIAGE AND MOUNT ...	3
A. Definition of Carriage and Mount	3
B. Mount	3
C. Carriage	3
CHAPTER 3. TYPES OF CARRIAGES AND MOUNTS	4
A. Monopod Mount	4
B. Bipod Mount	4
C. Tripod Mount	4
D. Antiaircraft Mount	5
1. For Machine Gun	5
2. For Artillery	5
E. Aircraft Mount	6
1. Fixed Mounting	6
2. Flexible Mounting	6
F. Mounts for Defense Armaments on Transport Vehicles	6
1. Truck Mount	6
2. Boat Mount	6
G. Tank Mounts	6
1. Combination Mount	6
2. Ball Mount	7
3. Gimbal Mount	7
H. Field Artillery Carriage	7
1. General	7
2. Single Trail	8
3. Split Trail	8
I. Self-Propelled Carriage	9
1. Tank Chassis	9
2. Double Recoil Type	9
3. Transportation	9
J. Mortar Mount	10
K. Railway Carriage	10
L. Fixed Emplacement Carriage	10
M. Recoilless Gun Mount	10

TABLE OF CONTENTS (Cont.)

	<i>Page</i>
CHAPTER 4. COMPONENTS OF A CARRIAGE OR MOUNT AND THEIR FUNCTIONS	11
A. Cradle	11
B. Recoil Mechanism	11
C. Top Carriage	12
D. Bottom Carriage	13
E. Equilibrator	13
F. Elevating and Traversing Mechanisms	13
CHAPTER 5. PRELIMINARY APPLIED DESIGN LOADS	15
A. Weight Estimates	15
B. Recoil Force	16
C. Buffer Force	17
D. Equilibrator Force	18
E. Elevating and Traversing Gear Loads	19
F. Trunnion Bearing and Traversing Bearing Loads	21
1. Trunnion Bearing Loads.....	21
2. Traversing Bearing Loads	22
G. Applied Loads During Transport	23
CHAPTER 6. SIZE OF STRUCTURE	24
A. Trunnion Height	24
B. Stability Effects of Structural Size	24
CHAPTER 7. PRELIMINARY DESIGN PROCEDURES FOR MORTAR MOUNTS	27
A. Structural Components	27
B. Mount	28
C. Base Plate	30
CHAPTER 8. SAMPLE CALCULATIONS	32
A. Weight Estimates	32
B. Preliminary Recoil Characteristics	32
1. Single Recoil System	32
2. Double Recoil System	32
C. Equilibrator Force	33
D. Elevating and Traversing Loads	33
1. Elevating Gear Load	33
2. Traversing Gear Load	34
E. Trunnion Bearing and Traversing Bearing Loads	34
1. Trunnion Bearing Load	34
2. Traversing Bearing Load	34
F. Size of Structure	35
1. Trunnion Height	35
2. Stability	35
GLOSSARY	37
REFERENCES	39

LIST OF ILLUSTRATIONS

<i>Title</i>	<i>Page</i>
Figure 1. Gun Carriage With Major Components	1
Figure 2. Monopod Mount	4
Figure 3. Bipod Mount	4
Figure 4. Bipod Mortar Mount	4
Figure 5. Tripod Mount	4
Figure 6. Tripod Antiaircraft Machine Gun Mount	5
Figure 7. Multiple Machine Gun Mount	5
Figure 8. Antiaircraft Gun Mount	6
Figure 9. Ring Mount	6
Figure 10. Truck Pedestal Mount	6
Figure 11. Pedestal Mounts on Landing Vehicle	6
Figure 12. Combination Gun Mount	7
Figure 13. Ball Mount	7
Figure 14. Gimbal Mount	7
Figure 15. Single Trail Field Carriages	7
Figure 16. Split Trail Field Carriage	8
Figure 17. Firing Base for Carriage	8
Figure 18. Tank Chassis Carriage	8
Figure 19. Double Recoil Weapon	9
Figure 20. Double Recoil Weapon, Detachable Prime Movers	9
Figure 21. Double Recoil Weapon, Semitrailer	10
Figure 22. Double Recoil Weapon, Attached Prime Mover	10
Figure 23. Cradle Showing Attachments	11
Figure 24. Hydropneumatic Recoil Mechanism	11
Figure 25. Top Carriage	12
Figure 26. Bottom Carriage	13
Figure 27. Spring Equilibrator	13
Figure 28. Elevating Mechanism	14
Figure 29. Traversing Mechanism	14
Figure 30. Muzzle Energy-Recoiling Parts Weight Ratio	16
Figure 31. Muzzle Energy-Weapon Weight Ratio	16
Figure 32. Equilibrator Geometry	18
Figure 33. Elevator Gear Loading Diagram	19
Figure 34. Traversing Gear Loading Diagram	21
Figure 35. Trunnion Bearing Loading Diagram	21
Figure 36. Traversing Bearing Loading Diagram	22
Figure 37. Side Slope Stability	24
Figure 38. Stability by Inspection—Single Recoil System	24
Figure 39. Stability by Inspection—Double Recoil System	24
Figure 40. Stability During Firing—Single Recoil System	25
Figure 41. Stability During Firing—Double Recoil System	25
Figure 42. Mortar	27
Figure 43. Typical Firing Data	27
Figure 44. Loading Diagram of Mortar	28
Figure 45. Pinned Ball and Socket Joint	29
Figure 46. Hand-Held Mortar	30
Figure 47. Base Plate With Spades	30
Table 1. Muzzle Energy-Weight Ratios	15

LIST OF SYMBOLS

<p> A_b = bore area A = projected area of mortar base spade a_m = mortar mount acceleration a_p = acceleration of prime mover a_r = recoil acceleration a_z = acceleration of secondary recoiling parts c = distance, trunnion to equilibrator pivot D_b = bore diameter E_m = muzzle energy E_s = energy of free recoil F_a = inertia force of recoiling parts F_b = buffer force; accelerating force of prime mover; residual force on mortar base cap F_{bs} = secondary buffer force F_E = equilibrator force F_e = effective pressure load F_g = propellant gas force F_{ga} = average propellant gas force F_{gm} = maximum propellant gas force F_i = inertia load of mortar mount F_s = maximum accelerating force exerted by prime mover F_s = side load on mount induced by transverse acceleration F_T = total trunnion load F_{TC} = inertia force of top carriage due to secondary recoil F_t = inertia force of primary parts due to secondary recoil F_{ts} = inertia force of primary parts due to secondary buffing F_{Tz} = inertia force of secondary recoiling parts g = acceleration of gravity h = distance of weapon center of gravity above ground h_m = distance between mortar mount attachment point and bore center line K = resistance to recoil; resistance to primary recoiling parts K_s = spring rate k_t = radius of gyration of tipping parts L = length of recoil L_{cp} = distance from mortar base plate socket to CG tube L_m = distance from base plate socket to mortar mount attachment </p>	<p> L_t = wheel span; length of tube L_o = equilibrator length when $\phi = 0$. L_1 = length of primary recoil L_2 = length of secondary recoil M_B = moment about mortar base socket M_g = mass of propellant gas M_p = mass of projectile M_r = mass of recoiling parts M_{tr} = moment about traversing axis M_w = weight moment of tipping parts M_{w0} = weight moment of tipping parts at zero angle of elevation m_t = mass of tipping parts m_1 = mass of primary recoiling parts m_2 = mass of secondary recoiling parts P_a = ground pressure on mortar base P_g = propellant gas pressure P_{ga} = average propellant gas pressure P_{gm} = maximum propellant gas pressure P_s = ground pressure on mortar base spade R = resistance to secondary recoil; equilibrator arm length R_a = axial reaction on mortar mount R_b = axial load on right leg of mortar mount R_e = total effective load on traverse bearing R_g = elevating gear tooth load R_h = horizontal reaction of trunnion; on mortar base plate R_i = inside radius R_m = ground reaction on mortar mount R_o = outside radius R_p = pitch radius of elevating arc; of traversing gear R_r = specific energy of recoiling parts \bar{R}_r = average specific energy of recoiling parts R_t = radius of CG of tipping parts about trunnions R_{tb} = reaction on traversing bearing R_{tg} = traversing gear tooth load R_v = vertical reaction of trunnion; on mortar base plate R_w = specific energy of weapon \bar{R}_w = average specific energy of weapon r_b = radius of mortar base </p>
---	---

T_a = accelerating torque for elevating tipping parts	W_1 = weight of primary recoiling parts
T_e = design torque of tipping parts	W_s = weight of secondary recoiling parts
T_f = firing torque	\bar{x}_a = distance from traversing bearing center to load center
T_i = torque induced by secondary acceleration	x_b = buffer stroke; primary buffer stroke
T_{tr} = design torque of traversing system	x_{bs} = secondary buffer stroke
v_f = velocity of free recoil	x_1 = distance from center of gravity of weapon to front support
v_{cr} = velocity of counterrecoil	y_T = trunnion height above ground
v_{crs} = velocity of secondary counterrecoil	α_e = elevating acceleration
v_m = muzzle velocity	α_{tr} = traversing acceleration
W = total weight of emplaced weapon; of towed weapon	β = gear tooth pressure angle; half angular spread between mortar mount legs
W_{BC} = weight of bottom carriage	θ = angle of elevation
W_b = weight of mortar base plate	θ_m = maximum angle of elevation
W_c = weight of cradle; of propellant charge	Φ_t = mass moment of inertia of tipping parts
W_g = weight of propellant gases	Φ_{tc} = mass moment of inertia of top carriage
W_m = weight of mortar mount	Φ_{tr} = mass moment of inertia of traversing parts
W_p = weight of projectile; of prime mover	$\#$ = angular displacement of CG of tipping parts; side slope
W_r = weight of recoiling parts	μ = coefficient of friction
W_{TC} = weight of top carriage	
W_t = weight of tipping parts, of tube assembly	
W_w = weight of towed weapon	

CHAPTER 1

INTRODUCTION

A. PURPOSE

1. *Carriages and Mounts—General* is the first in a series of handbooks dealing with gun carriages and mounts. Detailed discussions and design procedures for the individual components that form or are associated with carriages and mounts appear in the other handbooks of this series. These handbooks* are

- 341 *Cradles*
- 342 *Recoil Systems*
- 343 *Top Carriages*
- 344 *Bottom Carriages*
- 345 *Equilibrators*
- 346 *Elevating Mechanisms*
- 347 *Traversing Mechanisms*

This handbook introduces the subject. It provides descriptive material while specific design data and analyses of the various components are taken up in the succeeding handbooks. An effort is made to draw a distinction between a carriage and a mount since these terms have been used rather loosely in the past. The various types of carriages and mounts from a simple monopod, used for a light, automatic rifle, to a heavy artillery carriage are described.

2. A typical carriage with its major components is shown in Figure 1. Their functions, and where possible, the advantages of selecting one type over another are discussed. In order to make possible a preliminary weight estimate of a carriage, curves are included which have weights of weapon and recoiling parts plotted in relation to muzzle energy. Loads experienced in firing and transporting are discussed. General principles of good design are included.

B. DEFINITION

3. Gun mount is a generic term applied to any structure that supports a weapon. The carriage

*See inside back cover for information on handbook designation.

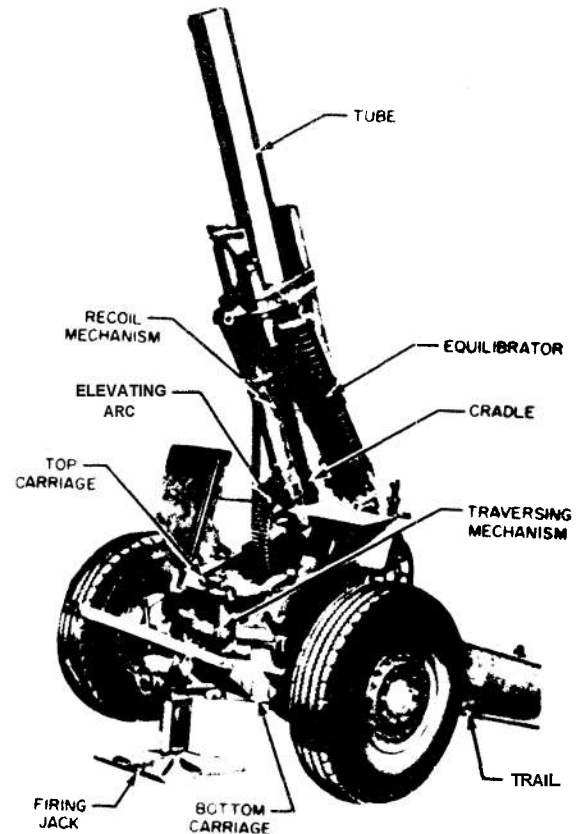

Figure 1. Gun Carriage With Major Components

may be a portion of the mount, or, in some cases, it may be the entire structure that supports and provides mobility for the weapon. Although not always true, *carriage* conveys the idea of a mobile structure, whereas the term *mount* is apt to be associated with weapons that are fixed in place, at least when prepared for firing.

C. FUNCTION

4. Regardless of whether termed carriage or mount, the primary function of the structure and its components is to support the gun, mortar, or rocket launcher during the firing of its missile. Another function involves recoil activity. Recoil

mechanisms moderate the forces induced by firing. On most field mortars, shock absorbers perform a similar function by reducing the shock on the mount. Other functions, including transport, traversing and elevating, depend on the type of weapon. In practically all weapons, traversing and elevating mechanisms adjust azimuth and ele-

vation, but to a degree limited by the type of weapon. The larger caliber weapons have equipment for loading and ramming ammunition installed on the mount. Many field artillery weapons are either self-propelled or have their own prime movers for transportation. Others use auxiliary facilities such as trucks or tractors.

CHAPTER 2

DISTINCTION BETWEEN CARRIAGE AND MOUNT

A. DEFINITION OF CARRIAGE AND MOUNT

5. In many weapons the distinction between the terms *carriage* and *mount* has become rather obscure. No doubt this has developed through the years; although there still seems to be some feeling that the term *mount* has a more general connotation, despite the fact that in some cases the term *carriage* has displaced it. This is particularly evident in the case of some towed weapons.

B. MOUNT

6. The mount may be considered to be the entire structure that supports a weapon. It does not, in itself, move in azimuth or elevation or during recoil. In the case of fixed emplacements the mount is usually attached to a large structure, whereas

in field artillery it rests on the ground. The transportation of the mount may be performed by a separate transporter or, in some cases, it is a vehicle capable of being towed.

C. CARRIAGE

7. As previously stated, the carriage may be a portion of a mount or may be considered complete in itself. Its fundamental function is to support the weapon during the firing cycle. It contains all the equipment for aiming and for absorbing the recoil forces. Wheels may be attached for traveling as a towed weapon, or the carriage may be supported by one or two transporters during traveling.

CHAPTER 3

TYPES OF CARRIAGES AND MOUNTS

A. MONOPOD MOUNT

8. The most elementary mount is the soldier's arm which supports his rifle while firing. For light automatic rifles or light machine guns a more stable rest and therefore better accuracy is available with a small monopod (Figure 2) which is attached to the barrel. Since these weapons are often fired from the prone position, the irregularity of the ground and the need to elevate the weapon requires some telescoping adjustment in the monopod.

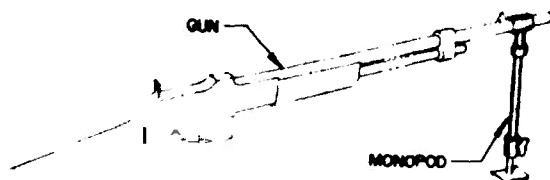

Figure 2. Monopod Mount

B. BIPOD MOUNT

9. Heavier automatic rifles and machine guns, needing more stable support than monopods provide, resort to bipod mounts (Figure 3). The two legs of the mount are adjustable to compensate for uneven ground and change in elevation. Tight field mortars have bipods and base plates (Figure 4). Screw arrangements provide limited elevation and traverse. The traversing and elevating mechanisms which rotate the tube about the base plate

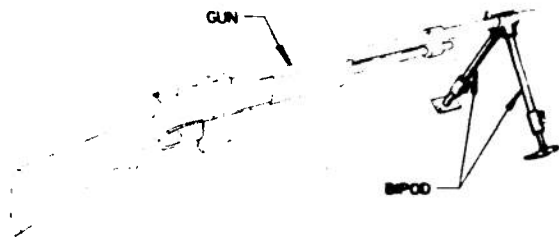

figure 3. Bipod Mount

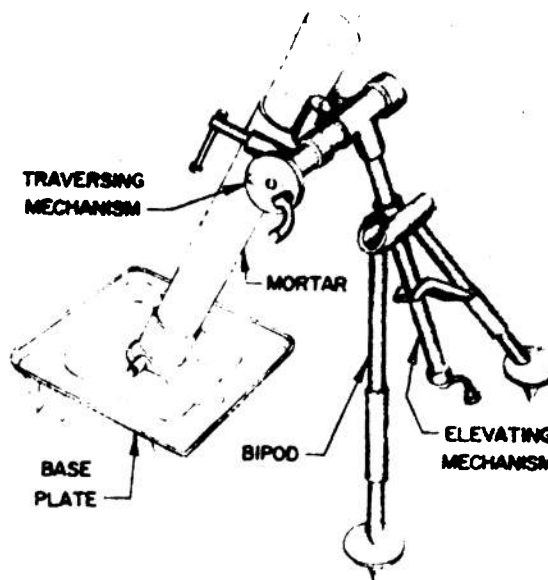

figure 4. Bipod Mortar Mount

usually consist of horizontal and vertical screws housed in tubular yokes and actuated by hand-wheels or cranks.

C. TRIPOD MOUNT

10. Tripod mounts for machine guns support the entire weapon. The gun is aimed directly by the gunner, thus permitting rapid changes in azimuth and elevation, or simple elevating and traversing mechanisms may be used for more stable and pre-

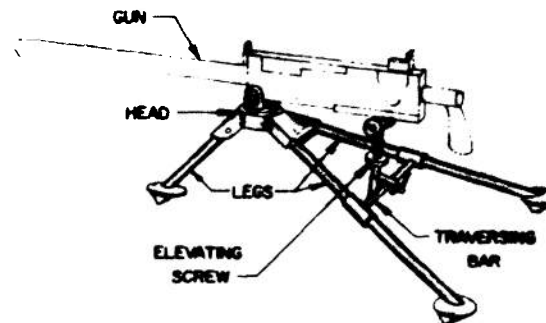

Figure 5. Tripod Mount

aise aiming (Figure 5). The tripod mount is used primarily for ground fire.

D. ANTI-AIRCRAFT MOUNT

1. For Machine Gun

11. Machine guns for antiaircraft use are mounted either singly or in multiple units. The pedestal mount for one machine gun is supported on a three- or four-legged stand (Figure 6). The pedestal extends upward to effect a high trunnion

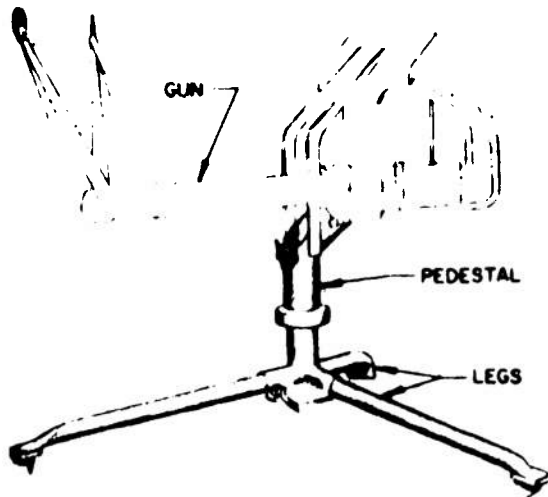

Figure 6. Tripod Antiaircraft Machine Gun Mount

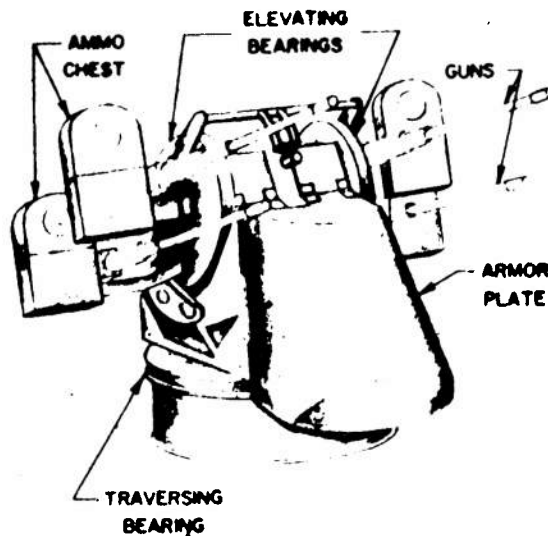

Figure 7. Multiple Machine Gun Mount

and, therefore, ground clearances adequate to permit unlimited high elevation and ample clearance for the gunner when moving with the gun. The mounts for multiple machine guns are of the pedestal type. Figure 7 shows a mount equipped with four machine guns. The mounts may be controlled manually or power-operated. In power-operated mounts, the power plant is self-contained. The multiple machine gun mount may rest on the ground or may be mounted on a vehicle or trailer. It has unlimited traverse, and the guns may be elevated to 90° or depressed below the horizontal. All activity during firing is controlled by the gunner seated centrally on the mount. Armor plate may be located in front of the gunner.

2. For Artillery

12. Existing mounts for antiaircraft artillery are of the pedestal type whether the installation is fixed or mobile (Figure 8). This type mount offers

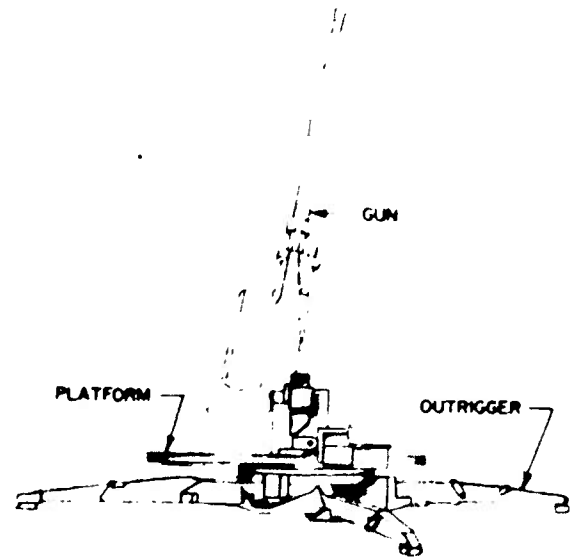

figure 8. Antiaircraft Gun Mount

the freedom of unlimited traverse and the high angles of elevation (80° or better) necessary for antiaircraft fire. Fixed installations formerly used for harbor defense are obsolete and have been replaced with transportable or mobile mounts capable of being moved to the site of action. These weapons range from 3 inches to 120 mm in caliber. The pedestal which rests on the ground has four

folding outriggers attached to its base to provide needed stability. This type mount increases the weapons' versatility by being stable at low angles of elevation thereby rendering the gun effective for general warfare as well as for defense against aircraft. The mount has the additional asset of being easily and rapidly emplaced.

E. AIRCRAFT MOUNT

1. Fixed Mounting

13. The mounts of guns and launchers in fighter type aircraft are usually attached rigidly to some part of the wing or in the forward part of the fuselage. Except for recoil action, no relative motion occurs between any component of the weapon and the aircraft. The guns are aligned with the axis of the plane and are aimed by aiming the aircraft.

2. Flexible Mounting

14. On large bomber type aircraft the guns and launchers may be installed on maneuverable mounts and turrets. Turrets are usually power-operated but have manual operating facilities in case of power failure. Firing is controlled by the gunner either remotely or from the proximity of the weapon; but, where unlimited traverse is available, firing is interrupted automatically when any part of the aircraft comes in the line of fire.

F. MOUNTS FOR DEFENSE ARMAMENTS ON TRANSPORT VEHICLES

1. Truck Mount

15. For self-defense against aircraft and ground fire, transport vehicles are equipped with machine guns mounted on circular tracks. The weapon, usually a caliber .30 or caliber .50 machine gun, is attached to a roller carriage that runs on a circular

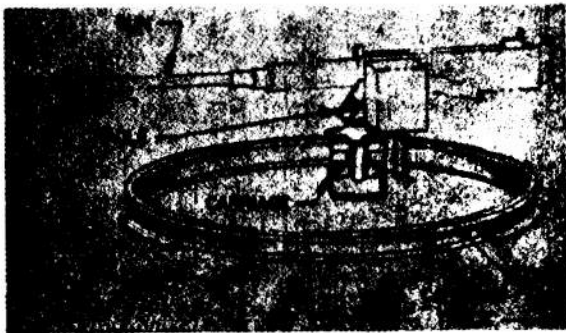

Figure 9. Ring Mount

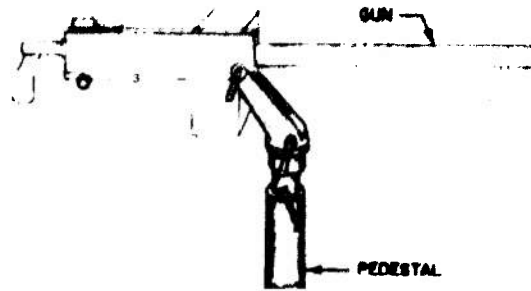

Figure 10. Truck Pedestal Mount

track thereby providing unlimited traverse (Figure 9). Complete overhead coverage is achieved by raising the track for the necessary ground clearance. This type of installation is used on landing vehicles, light armored cars, utility cars, personnel carriers, half tracks and motor carriages. If complete coverage is not desired for these vehicles, pedestal mounts with limited traverse and elevation are used (Figure 10). The pedestal is attached to any convenient part of the vehicle's structure where effective firing can be realized.

2. Boat Mount

16. Machine guns on pedestal mounts are used on small boats and landing craft for limited protection against ground forces and low flying aircraft. This type of mount is convenient for installation where space is limited (Figure 11).

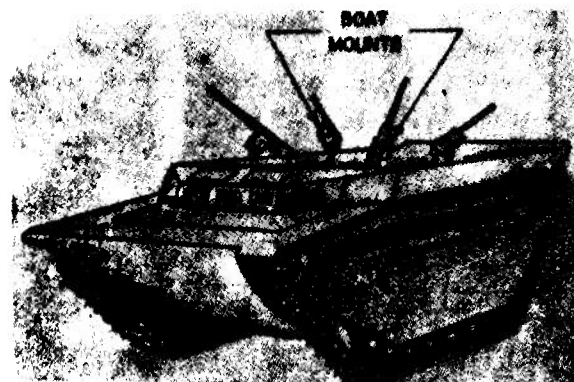

figure 11. Pedestal Mounts on landing Vehicle

G. TANK MOUNTS

1. Combination Mount

17. A combination mount in the turret of a tank houses two guns, a machine gun and the primary

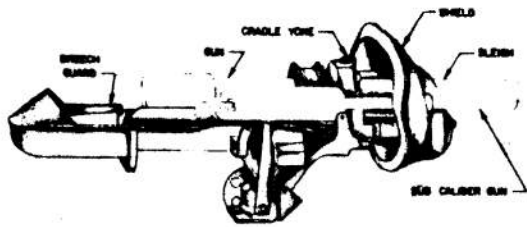

Figure 72. Combination Gun Mount

armament weapon (Figure 12). The machine gun, referred to as a spotting rifle or a coaxial gun, is fired to a fix on the target before the larger caliber weapon is fired. The mount has limited elevation but the turret provides unlimited traverse.

2. Ball Mount

18. A ball mount is used in tanks to support secondary armament such as machine guns. This mount is essentially a ball and socket arrangement with the gun attached to and passing through the ball unit (Figure 13). Close confinement due to

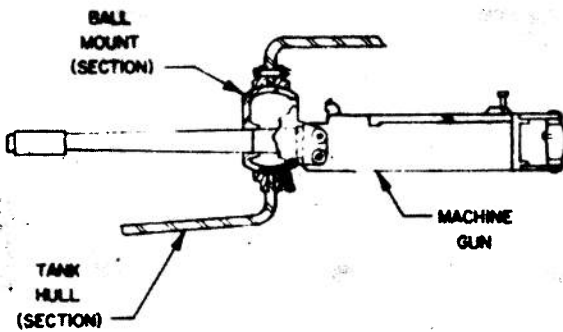

Figure 13. Ball Mount

structural interferences limits both elevation and traverse, but not sufficiently to impair the tactical use of the weapon.

3. Gimbal Mount

19. The gimbal mount (Figure 14) supports light artillery weapons in tank turrets. Elevation and traverse with respect to the turret are limited, but traverse with respect to the tank is unlimited due to the unrestricted rotation of the turret.

H. FIELD ARTILLERY CARRIAGE

1. General

20. Conventional field artillery carriages with trails mount a variety of weapons ranging in cal-

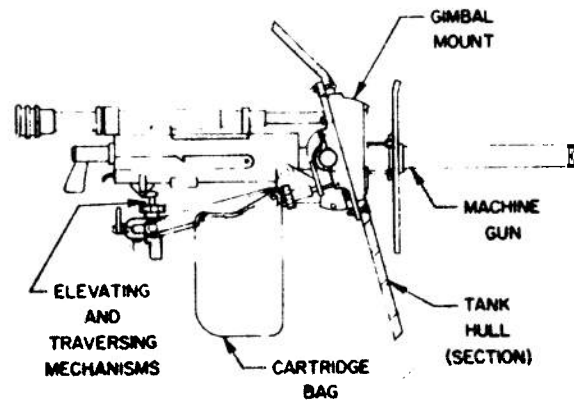
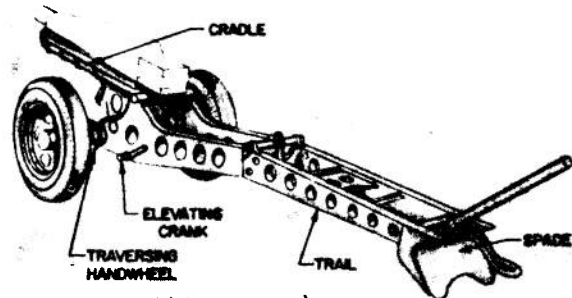

Figure 74. Gimbal Mount

iber from the 37 mm gun used by the infantry to the heavy field pieces such as the 8-inch gun and the 240 mm howitzer. These carriages have single or split trails to carry rearward loads and to provide the necessary stability. Light artillery pieces may be fired with the pneumatic tires resting on the ground whereas the heavier pieces are fired



(a) EARLY FIELD TYPE

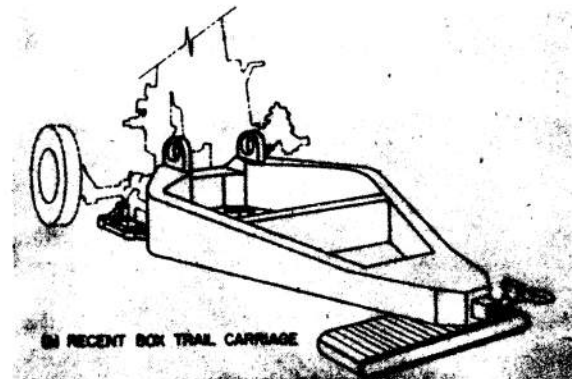

Figure 75. Single Trail Field Carriages

with the carriage supported on a firing base, the wheels being lifted off the ground or removed with the bogie.

2. Single Trail

21. Early field artillery was equipped with single trails (Figure 15a). The single trail is a simple arrangement conducive to rapid emplacement and providing a ready tow bar. Traverse which is limited to only a few degrees is obtained by sliding the unit on its axle. Elevation, because of interference with the trail structure, is limited to about 20 degrees. These restrictions reduce the weapon's effectiveness to the point that this type is used only for light transportable weapons such as pack howitzers.

The recently designed box trail carriage (Figure 15b) is a modified single trail type capable of 360° traverse. The front ends of the carriage are supported by a circular platform on which it pivots while the rear end of the trail rests on a crawler type traversing mechanism which can position the weapon over the full 360° range. Providing ample space inside for the loader to work during firing, the wishbone-shaped box structure combines the advantages of simplicity found in the single trail with the versatility of the split trail and still retains good rigidity-weight characteristics.

3. Split Trail

22. Usage has made the split trail carriage the standard type for field artillery (Figure 16). This type offers several advantages over the single trail type—it permits a longer recoil and therefore lower forces, higher angles of elevation, greater traverse, and greater stability. Angles of elevation may be as high as 65° while traverse may

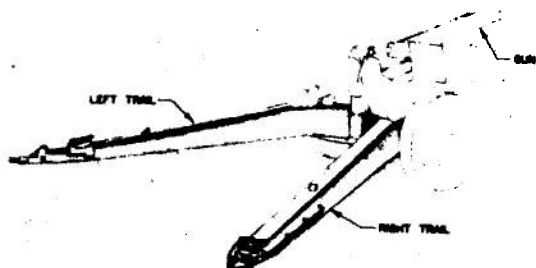

Figure 16. Split Trail Field Carriage

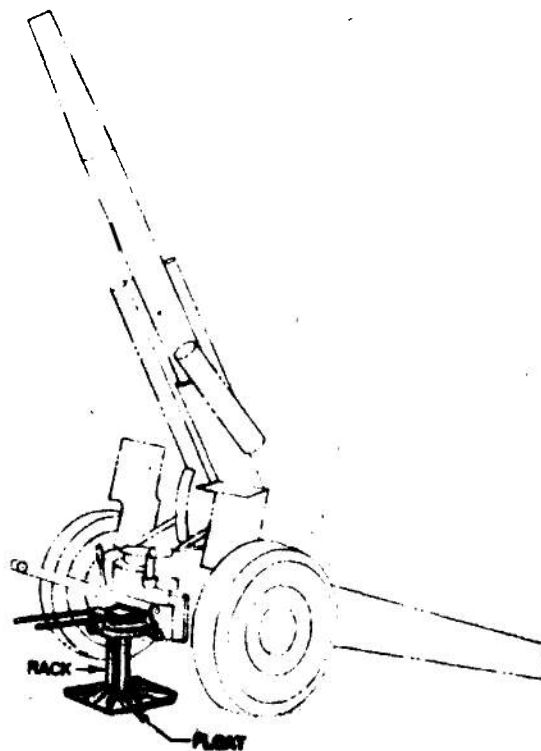

Figure 17. Firing Base for Carriage

swing through any arc within the confines of the trail spread. For those weapons not supported by wheels during firing, a firing base similar to that in Figure 17 provides support at the front of the carriage.

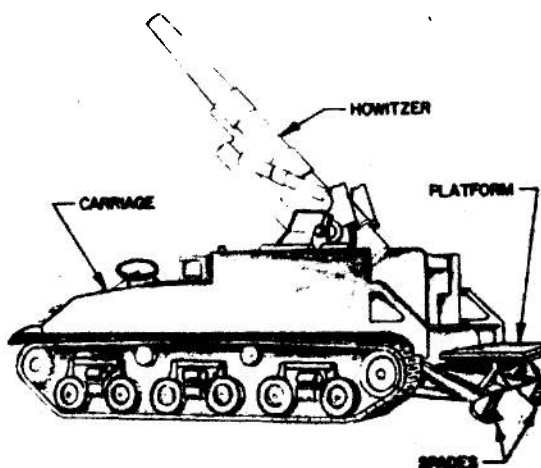

Figure 18. Tank Chassis Carriage

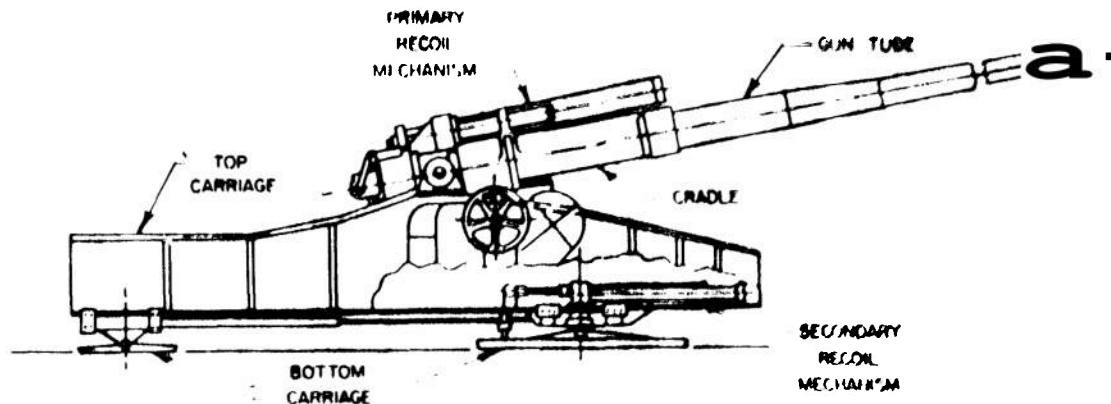

Figure 19. Double Recoil Wwpsn

J. SELF-PROPELLED CARRIAGE

1. Tank Chassis

23. To obtain cross country mobility of heavy field artillery for fluid warfare, weapons have been mounted on tank chassis such as the howitzer shown in Figure 18. Resistance to recoil is offered by large spades hinged as a unit to the rear of the chassis which dig themselves into the ground during firing. No further restriction is offered by this mount, the limits being those of the split trail type. On the other hand, fine traverse is severely limited to a few degrees but coarse traverse, available by simply turning the vehicle, is unlimited.

2. Double Recoil Type

The principal feature of the double recoil weapon is the ability to utilize the mass of the top carriage to help moderate recoil forces. Such a weapon is illustrated in Figure 19. Two recoil systems are involved, the primary system of the gun which is directly affected by the dynamics of the round and the secondary system of the top carriage which controls the impetus of the primary system.

24. On large caliber weapons, the double recoil type of carriage offers advantages that are of a real value in modern fluid warfare. One is the considerable reduction in horizontal ground forces as compared to those experienced in single recoil guns. These low forces and the general structure of the firing base require less staking and little or no ground preparation, both conducive to very

rapid emplacement and displacement which are now a matter of minutes rather than six to eight hours for other large caliber weapons. The stability of the weapon is excellent even at negative angles of fire. From the economic viewpoint, the relatively low recoil forces generally lead to a low weight structure. Although fine traverse is limited to about $\pm 15^\circ$, it is not a serious disadvantage since coarse traverse is unlimited and quickly attained. The double recoil type of carriage need not be restricted to double recoil systems. This type of structure can readily be adapted to single recoil systems simply by eliminating the secondary recoil activity. Although the recoil forces will be the same as those for the split trail types of carriage, all the other advantages of double recoil type of structure will be retained.

3. Transportation

25. Double recoil weapons may be transported by any combination of several methods. A double tractor forms one combination (Figure 20). Another is a semitrailer with bogie (Figure 21). A

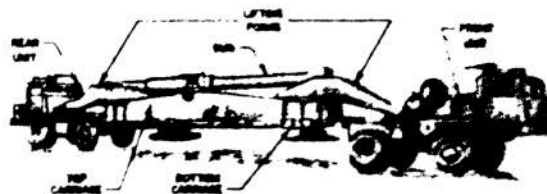

Figure 20. Double Recoil Weapon, Detachable Prime Movers

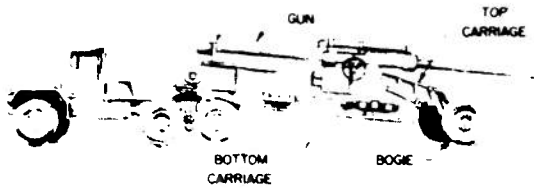

Figure 21. Double Recoil Weapon, Semitrailer

third is a full trailer with bogie and limber, the entire unit being towed by a prime mover. Other units represent a combination of these three. The conveyers may be detachable or attached to the structure. Even the prime mover may be attached, Figure 22 being a sketch of a concept of this type.

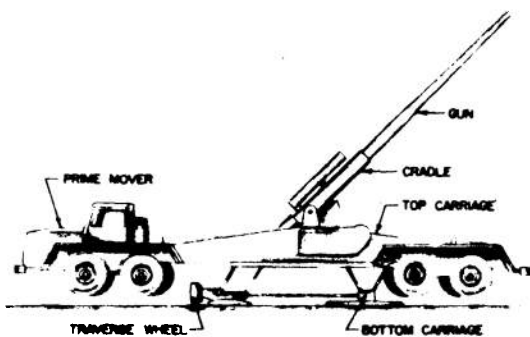

Figure 22. Double Recoil Weapon, Attached Prime Mover

The additional mass of the prime mover increases the effectiveness of the secondary recoil system. In these installations, the designer must be aware that all parts of bogie, limber, or prime mover are subjected to secondary recoil accelerations and must be designed accordingly.

K. MORTAR MOUNT

26. Mortars are the simplest form of artillery, used primarily for short range at high angles of elevation. There are two types, the fixed and the mobile. The fixed mount mortars, now obsolete, were usually of large caliber used for harbor defense. The mobile mounts, being transportable, may be emplaced on any convenient site. Mortars may range in size as widely as other artillery weapons. For the smaller calibers, the mount is usually of simple construction, consisting of a base to absorb the firing loads and a bipod to lend stability to the weapon and to provide limited elevation and traverse. Figure 4 shows such a mount. Figure

46 illustrates an even simpler structure, for a hand-held mortar. The mounts for the larger calibers, because of much greater firing loads, should be provided with some means of moderating these loads.

L. RAILWAY CARRIAGE

27. Railway-mounted heavy artillery was first used during the Civil War. Its development continued through and after World War I, but aircraft bombing assumed the mission of these long-range weapons to the point that they are now considered obsolete. However, the use of railway mounts may be revived since the advent of the missile. This is based on the supposition that railroads augment the mobility aspects of transporting launchers to convenient and tactically advantageous sites.

M. FIXED EMPLACEMENT CARRIAGE

28. Fixed emplacement carriages, including the disappearing, barbette, and pedestal types, were primarily used in harbor and city defense. They usually mounted large caliber guns, howitzers and mortars. These weapons were located at strategic locations, always ready for action, and well protected by fortifications. Permanent facilities such as communications, fire control equipment, and ammunition storage were used to full advantage. Ample power was available to the site and was used freely thereby eliminating the need for extensive auxiliary units. However, the mobile bases of naval aircraft and the extended range of land based aircraft has placed an attacking force beyond the range of these weapons. Additionally, modern explosives and design of fortification-piercing bombs have made the use of fixed fortifications impractical. Thus the very features which made the permanent emplacement highly desirable have been responsible for its present obsolete status.

N. RECOILLESS GUN MOUNT

Recoilless guns induce little or no recoil force, therefore mounts are needed for holding and positioning only. Any simple structure of sufficient stability such as a tripod, or a mere saddle to hold it on the gunner's shoulder, is adequate to support a weapon of this type. When mounted on vehicles, these mounts should be strong enough to sustain the accelerations induced by vehicular travel.

CHAPTER 4

COMPONENTS OF A CARRIAGE OR MOUNT AND THEIR FUNCTIONS

A. CRADLE

29. The cradle is one of the components that make up a carriage or mount (Figure 23). An-

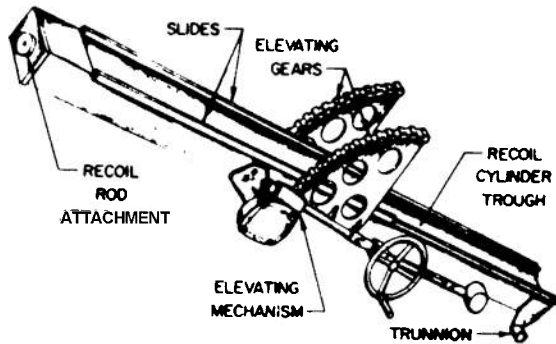

Figure 23. Cradle Showing Attachments

other handbook" deals specifically with the cradle, discussing it in detail along with its components and pertinent design data. The cradle is one of the tipping parts serving as the supporting structure for all other tipping parts. Its primary function is to support the gun tube. It has guides or tracks on which the tube slides during recoil and counterrecoil. It anchors the recoil mechanism. It prevents the tube from rotating. It transmits all loads including those of recoil, tube whip, and rifling torque, to the top carriage primarily through the trunnions. Incidental loads are transmitted by other units such as elevating mechanisms and equilibrators.

30. Aside from the strength and functional requirements the most demanding one of the cradle is its ability, by virtue of its trunnions, to provide a firm and reliable base for the fire control equipment that may be mounted on it. Absolute rigidity is optimum but never attained. The structure will deflect and clearances between moving surfaces will cause some misalignment. However, both these unfavorable aspects can be minimized

* Reference 1.

through good engineering practices. Machined surfaces with low tolerances and small clearances are helpful. Symmetrical structures generally deflect symmetrically therefore less compensation for misalignment is needed. Regardless of the developed misalignments, whether by clearances between mating surfaces or by structural deflections, the fire control engineer should be made cognizant of the extent of these deflections so that he can design his equipment accordingly. These deflections because of indeterminate nature of structure and joints, are not accurately predictable; therefore a prototype weapon may be needed to aid the fire control designer.

B. RECOIL MECHANISM

31. A recoil mechanism moderates the firing loads on the supporting structure of a gun by prolonging the time of resistance to the propellant gas forces. As the gas pressure propels the projectile toward the muzzle, it exerts an equal and opposite force on the breech which drives the gun rearward. The recoil mechanism cushions this force and limits the rearward motion and then returns the gun quickly to the in-battery position. The return motion is called counterrecoil.

Most recoil mechanisms belong either to the hydrospring or to the hydropneumatic type shown in Figure 24. A mechanical spring in the former and gas under pressure in the latter store some of the recoil energy for counterrecoil. Both meeh-

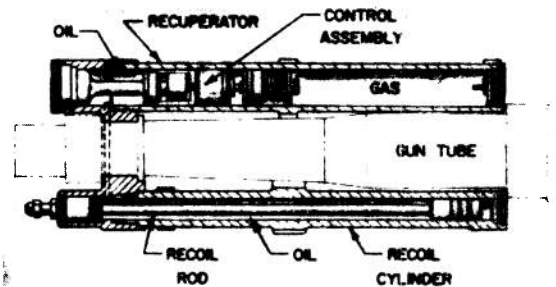

Figure 24. Hydropneumatic Recoil Mechanism

anisms absorb recoil energy by restricting the flow of hydraulic fluid with a regulated orifice. During counterrecoil, the moving mass is brought to a stop with buffers which act over a short distance terminating at the in-battery position.*

32. Recoil systems consisting of recoil mechanisms and associated recoiling parts comprise two types. One is the single recoil system whose recoil mechanism and recoiling parts move as a single coordinate unit in one rearward direction. The other is a double recoil system consisting of two separate units of recoiling parts, with both coordinated units moving in the same general direction but not necessarily in parallel paths. The unit containing the gun tube, i.e., the primary system, is equivalent to the single recoil system.

C. TOP CARRIAGE

33. The top carriage is the primary supporting structure of the weapon (Figure 25). While a

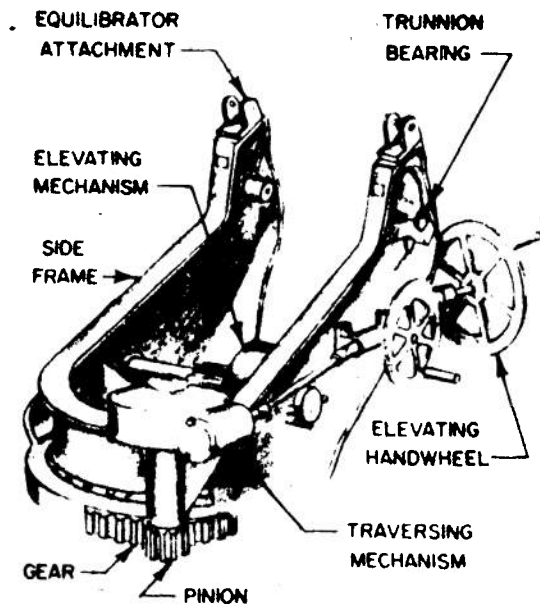

Figure 25. Top Carriage

rigid cradle is a requisite, a rigid top carriage also is needed, to extend the firm base required for fire control. It supports the tipping parts through the trunnion bearings and transmits all firing loads

*Recoil activity and design of recoil systems are discussed in detail in Reference 2.

from the cradle to the bottom carriage or other supporting structure. It anchors the equilibrators. It houses the elevating and traversing mechanisms and the power units if needed for these mechanisms. In traverse, the top carriage moves with the cradle and, in double recoil systems, these two units constitute the bulk of the secondary recoiling mass. Design data, procedures and requirements are discussed in detail in another handbook.*

34. Trunnion and traversing bearings provide the low-friction rotating elements which are so essential during elevation and traverse. Either sleeve or roller bearings are used. Structurally speaking, the bearings must be strong enough to support the large firing loads. In addition, they must permit the units to rotate freely as the weapon is elevated or traversed. If either ball or roller type, they are selected according to manufacturers' specifications. Bearings with rolling elements have a basic static-load rating determined by a combined permanent deformation of ring and rolling element. Sometimes the static load rating can be greatly exceeded without deleterious effects. In this respect, the rating may be doubled for trunnion and traverse bearings without impairing weapon accuracy. It is advisable to consult bearing authorities before the final selection, particularly if any design feature remains questionable. Sleeve bearings are designed according to the strength of the material for static load but when turning, the bearing pressure should not exceed 300 psi.

35. Top carriages are of two types: the single recoil and the double recoil. The top carriage for a single recoil weapon is a simple structure consisting basically of two side frames supported by a base plate (Figure 25). Whatever complexity the structure ultimately acquires is primarily due to the provision of convenient and adequate attachments for the mechanisms which it supports. It is supported by the bottom carriage or equivalent structures on which it rotates. It has no other motion. The double recoil type of top carriage (shown in Figures 20, 21, 22), despite its name, is not restricted to double recoil guns. It may be used for single recoil weapons as well, retaining all its inherent advantages except those derived

*Reference 3.

from double recoil activity. The components of this type of top carriage have basically the same functions as their counterparts in the single recoil weapon. However, its size and shape and structural requirements differ materially. While the top carriage of a single-recoil weapon only rotates with respect to the bottom carriage, that of a double recoil weapon also translates but only during the recoil cycle. Its chief assets stem from its quick emplacement features and its role in the secondary system which, in essence, is equivalent to a longer recoil stroke with a corresponding decrease in force.

D. BOTTOM CARRIAGE*

36. The bottom carriage supports the top carriage and provides the pivot for the traversing parts. It and its components are the structural foundation of the weapon (Figure 26). During

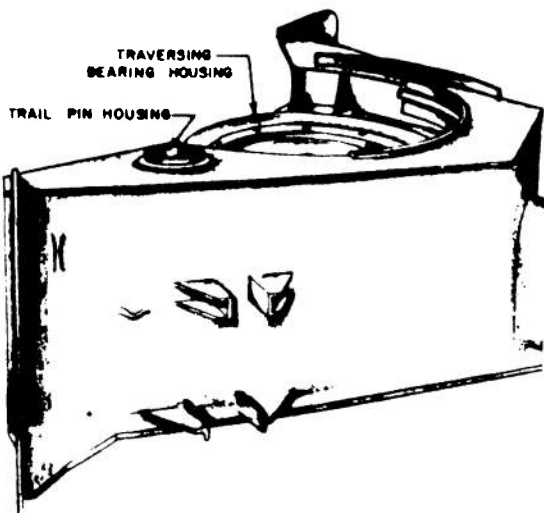

Figure 26. Bottom Carriage

firing it transmits all top carriage loads to the ground. During transit it becomes the chassis for single recoil type weapons or, as part of a double recoil system, it is retractable and hence, relieved of this function. It houses part of the traversing mechanism. It anchors the secondary recoil mechanism of double recoil systems. In single recoil weapons it may include trail or outriggers, spades and floats. Although some structures are called

* Reference 4.

pedestals, platforms, or supports, all are essentially bottom carriages from the functional point of view and the same design philosophy applies for all.

E. EQUILIBRATOR*

37. An equilibrator is a force-producing mechanism of a weapon which provides the moment needed to balance the muzzle preponderance of the tipping parts (Figure 27). It functions as a me-

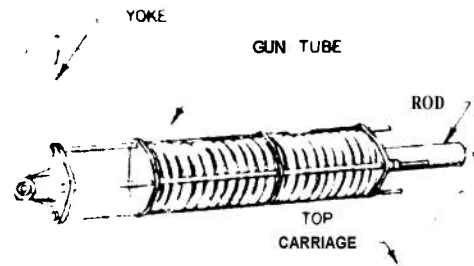

Figure 27. Spring Equilibrator

chanical counterweight but is considerably smaller, lighter, and more practicable in field use than its massive counterpart. Equilibrators are essential for modern weapons particularly since their use enables artillery to have a desirable low silhouette with low center of gravity while still being capable of firing at high as well as low angles of elevation. Proper ground clearance during recoil is achieved by locating the gun tube so that the center of gravity of the tipping parts is well forward of the trunnions. The large weight moment created by this overhung mass is then balanced by the equilibrator.

F. ELEVATING AND TRAVERSING MECHANISMS**

38. The long range of projectiles and missiles requires precise aiming to assure a reasonable degree of accuracy. When aimed by direct sighting, a weapon must be moved slowly and precisely to align it accurately with the target. When aimed by a fire control unit, the cannon or launcher must be able to respond accurately to the direction signals of the unit. In either case, such a weapon

* Reference 5.

** References 6 and 7.

is too heavy to be aimed directly by hand. Hence, handwheel or power-operated mechanisms are provided to enable gunners to attain precise positions in elevation and azimuth and hold them during firing. The angle of elevation corresponding to the distance between gun and target is obtained by rotating the tipping parts and, therefore, gun tube about the cradle trunnions. The elevating mechanism is the apparatus which imparts this rotation (Figure 28). Its horizontal counterpart, the traversing mechanism (Figure 29), rotates the traversing parts which generally consist of the cannon and other tipping parts and the top carriage.

39. The elevating and traversing mechanisms and their controls must be designed for easy operation to the extent that the gunner can devote most of his attention to the target. These mechanisms

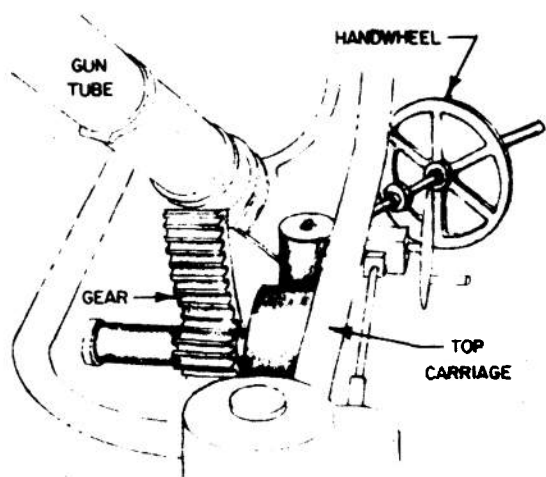

Figure 28. Elevating Mechanism

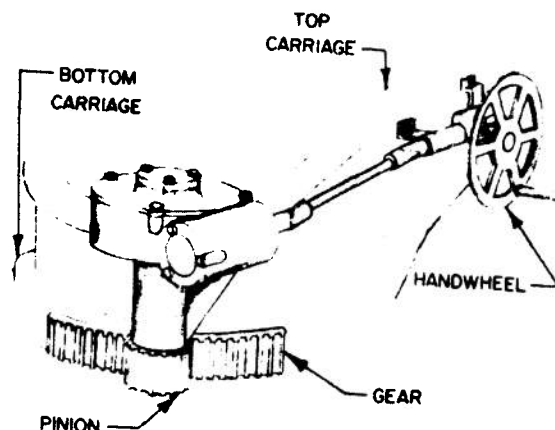

Figure 29. Traversing Mechanism

are essentially gear trains or linkages ; one terminal at the power source, the other on the tipping or traversing parts. The gear train uses either a self-locking worm and worm-wheel assembly or a mechanical brake to hold the rotating parts in the prescribed position. Manual- and power-operated types form the two general categories. Manual-operated units alone are installed on those weapons which do not demand activity at high torques, at high speeds, or for prolonged periods. Effort is applied by a handwheel. If elevation or traverse is too burdensome, the mechanism must derive power from mechanical or electrical sources. However, these mechanisms are operated by handwheel in the event of power failure.

CHAPTER 5

PRELIMINARY APPLIED DESIGN LOADS

A. WEIGHT ESTIMATES

40. The preliminary design of gun carriage or mount can be started concurrently with or even before the tube design when the only known data are the muzzle velocity and weight of the projectile. Later, when the design is more detailed, rod pull will be the controlling factor in determining size and therefore weight of structure, whether the recoil mechanism acts alone or in conjunction with a muzzle brake. These data are all that are needed for a preliminary estimate of the total weight of the weapon and the weight of the recoiling parts,

$$E_m = \frac{1}{2} M_p v_m^2 \quad (1)$$

where

M_p = mass of projectile

v_m = muzzle velocity

Estimates of the weights of weapon and recoiling parts are determined from the two ratios

$$R_w = \frac{E_m}{W}, \text{ specific energy of weapon} \quad (2a)$$

$$R_r = \frac{E_m}{W_r}, \text{ specific energy of recoiling parts} \quad (2b)$$

where

W = total weight of emplaced weapon

W_r = weight of recoiling parts

The two ratios are computed for twelve contemporary weapons consisting of guns and howitzers, ranging in caliber from 57 mm to 240 mm are listed in Table 1. Several other relationships of momentum-weight and energy-weight were investigated but did not compare favorably with R_w and R_r statistically

$$\bar{R}_w = \frac{\Sigma R_w}{12} = \frac{3856}{12} = 321 \text{ ft-lb/lb}$$

$$\bar{R}_r = \frac{\Sigma R_r}{12} = \frac{12601}{12} = 1050 \text{ ft-lb/lb}$$

TABLE 1 MUZZLE ENERGY-WEIGHT RATIOS

Weapon	W 1000lb	W_r 1000lb	W_p lb	v_m ft/sec	E_m 10 ⁶ ft-lb	R_w ft-lb/lb	R_r ft-lb/lb
57 mm G	2.7	0.8	6.28	2700	0.71	262	888
75 mm G	3.4	0.9	14.96	2030	0.96	282	1063
3-in G	5.2	1.6	12.87	2800	1.57	301	980
90 mm G	12.5	2.6	23.4	2700	2.65	212	1020
105 mm H	4.9	1.1	33.0	1550	1.23	251	1115
4.5-in G	12.3	4.1	54.9	2275	4.41	358	1075
120 mm G	48.0	10.8	50.0	3100	7.45	155	690
155 mm H	12.0	3.9	94.8	1850	5.03	418	1290
155 mm G	27.7	9.8	95.6	2800	11.63	420	1190
175 mm G	49.9	14.6	150.0	2850	18.90	378	1295
8-in G	69.5	30.2	240.0	2600	26.20	363	835
240 mm H	64.7	25.5	360.0	2300	29.60	456	1160

H = Howitzer; G = Gun; W_p = weight of projectile.

When based on the average values shown as R_w and R_r , the estimated weights of weapon and recoiling parts are conservatively high. A more realistic approach involves the curves of Figures

30 and 31 which show the spread of the data in Table 1. This large spread inhibits consistency and is therefore replaced by one line in each figure. Available stronger material and new tech-

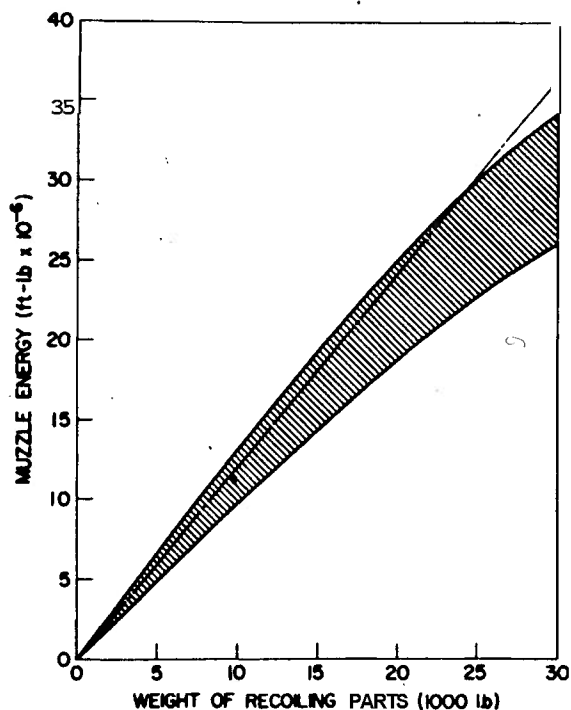

Figure 30. Muzzle Energy-Recoiling Parts Weight Ratio

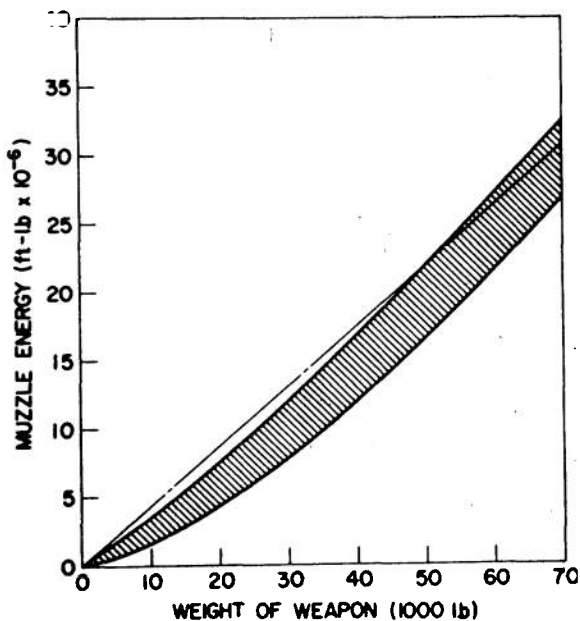

Figure 31. Muzzle Energy-Weapon Weight Ratio

niques in design combined with modern design philosophy follow the trend toward lighter equip-

ment. Therefore the straight lines conforming closest to the upper boundaries of the shaded areas should be used for determining the preliminary weights. The equations based on the straight lines are

$$W_r = 8.2 \times 10^{-4} E_m \text{ lb} \quad (3)$$

$$W = 22.8 \times 10^{-4} E_m \text{ lb} \quad (4)$$

B. RECOIL FORCE

41. The recoil force is the principal design load of the gun carriage. The force is proportional to the size of weapon, i.e., heavy artillery has large recoil forces whereas light artillery and small arms have correspondingly smaller recoil forces. The recoil force can be estimated quickly. It is derived from the velocity of free recoil and the length of recoil. Free recoil assumes the gun to recoil horizontally without resistance. The maximum velocity of free recoil

$$v_r = \frac{W_p v_m + 4700 W_g}{W_r}, \text{ ft/sec*} \quad (5a)$$

where

W_g = weight of propellant gases, **b**

W_p = weight of projectile, lb

W_r = weight of recoiling parts, lb

v_m = muzzle velocity, ft/sec

The energy of free recoil

$$E_r = \frac{1}{2} M_r v_r^2 \quad (5b)$$

where

M_r = mass of recoiling parts

The average required resistance to recoil*

$$K = \frac{E_r}{L} + W_r \sin \theta = F_a + W_r \sin \theta \quad (6)$$

where

L = length of recoil

F_a = inertia force of recoiling parts

θ = angle of elevation

42. Of the four factors in Equation 6 which determine the recoil resistance, the length of recoil, L , appears to be an arbitrary choice, as well it may. However, an estimate of a reasonable length should be attempted. The first choice of L is seldom accurate and because the correct length is

* Reference 8, page 242.

* Reference 2, Equation 3b.

found by iterative calculation, the first approximation should be near the maximum. A practical recoil stroke length

$$L = 10D_b \quad (7)$$

where $D_b =$ bore diameter.

Later, when the carriage design is more complete, the recoil stroke may be adjusted to suit final conditions. The longer the recoil, the lower the recoil force and hence, the lighter the carriage. However, a desirable low silhouette with corresponding low trunnion height severely limits the length of recoil, especially at high angles of elevation when clearance between ground and recoiling parts is not readily realized. For this reason, length of recoil and trunnion height become compromising parameters, each being selected within the compatible limits of the other.

43. Caliber of gun suggests the general size of carriage or mount. Large guns exert large forces, and supporting structures, to be capable of sustaining these forces, will correspond in size to the magnitude of the applied forces. Since recoil force varies inversely with recoil length, a weapon having long recoil requires a light structure but

not necessarily a low one. Since ground clearance is essential, and ample ground clearance may mean high trunnions which impede stability at low angles of elevation, the solution is a variable recoil, i.e., short recoil at high angles with corresponding high, manageable recoil forces, and long recoil at low angles of elevation with recoil forces low enough for weapon stability.

44. The double recoil system in which the top carriage recoils as a secondary mass, is also conducive to stability at low angles of elevation. Pertinent weights are estimated similarly to those of the single recoil weapons by Equations 3 and 4. But, two additional data are needed, the secondary recoil force and the weight of the secondary recoiling parts. Based on experience, the secondary recoiling parts will weigh about 1.5 times as much as the primary recoiling parts. Therefore the ratio

$$\frac{m_1 + m_2}{m_1} \approx 2.5 \quad (8)$$

where

$m_1 =$ mass of primary recoiling parts

$m_2 =$ mass of secondary recoiling parts.

The primary recoil resistance

$$K = \frac{m_1 v_f^2}{2L_1} \left(1 - \frac{L_2 \cos^2 \theta}{L_1 \cos \theta + L_2 \frac{m_1 + m_2}{m_1}} \right) + W_1 \sin \theta \quad (9)$$

where

$L_1 =$ length of primary recoil

$L_2 \leq 5/3 L_1$, length of secondary recoil

$W_1 =$ weight of primary recoiling parts computed as W_r in Equation 3.

The secondary recoil resistance

$$R = \frac{1/2 m_1 v_f^2 \cos^2 \theta}{L_1 \cos \theta + L_2 \frac{m_1 + m_2}{m_1}} \quad (10)$$

Maximum and minimum primary recoil forces occur respectively at maximum and minimum angles of elevation whereas, according to Equation 10, the converse is true for the secondary recoil force. Although Equation 10 indicates otherwise, numerical integrations that have been performed for double recoil systems have shown that the secondary forces vary only slightly as the angle of

elevation changes. The secondary recoil force computed from Equation 10 for 20° angle of elevation closely approximates the rigorously computed value. Early estimates of recoil forces, whether for single or double recoil systems, are sufficiently accurate that radical changes in structure become unnecessary when the design is finalized.

C. BUFFER FORCE

45. Buffering forces at the end of counterrecoil are not large enough to affect the general design of the carriage structure but may be critical with respect to weapon stability. Counterrecoil velocity and buffer stroke are closely associated with rate of fire. In rapid fire guns, time of recoil and counterrecoil are determined by the firing cycle. In artillery where time is not critical, recoil time is secondary to force and length of recoil, and a counterrecoil velocity of 3 to 4 feet per second is adequate. With counterrecoil velocity known, the

* Reference 2, Equation 72.

** Reference 2, Equation 73.

buffer force may be estimated for single recoil systems and for the primary recoiling parts of double recoil systems by assuming constant deceleration for the counterrecoiling mass. Therefore, buffer force

$$F_b = \frac{M_r v_{cr}^2}{2 x_b} \quad (11)$$

where

$$\begin{aligned} M_r &= \text{mass of recoiling parts} \\ v_{cr} &= \text{velocity of counterrecoil} \\ x_b &= \text{buffer stroke} \end{aligned}$$

For the first estimate, let the buffer stroke equal 25% of length of recoil, whether in single or double recoil guns.

46. The forces in a double recoil system produced by buffering the secondary recoiling parts are also found by assuming constant deceleration. Since there is no relative motion between primary and secondary recoiling parts during secondary buffering, the kinetic energy of the two masses moving as a unit must be absorbed by the secondary buffer whose force

$$F_{b2} = \frac{(m_1 + m_2)}{2 x_{b2}} v_{cr2}^2 \quad (12a)$$

where

$$\begin{aligned} m_1 &= \text{mass of primary recoiling parts} \\ m_2 &= \text{mass of secondary recoiling parts} \\ v_{cr2} &= \text{velocity of secondary counterrecoil} \\ x_{b2} &= \text{secondary buffer stroke} \end{aligned}$$

The inertia force of the primary recoiling parts due to secondary buffering

$$F_{i2} = \frac{m_1}{m_1 + m_2} F_{b2} \quad (12b)$$

and that of the secondary recoiling parts

$$F_{i2} = \frac{m_2}{m_1 + m_2} F_{b2} \quad (12c)$$

D. EQUILIBRATOR FORCE

47. The equilibrator force necessary to produce a moment about the trunnions to balance the weight moment is readily computed once the weight and mass center of the tipping parts are known. For preliminary estimates, assume that the weight of the cradle comprises 25% of the weight of the tipping parts. Thus, the weight of the cradle

$$W_c = 0.25 W_t = 0.25 (W_r + W_c) \quad (13a)$$

where

$$\begin{aligned} W_r &= \text{weight of recoiling parts} \\ W_t &= \text{weight of tipping parts} \end{aligned}$$

For preliminary estimates, the weights of other items such as the recoil cylinder are relatively small and are considered negligible.

Collecting terms and solving for W_t

$$W_t = \frac{1}{3} W_r \quad (13b)$$

Although the position of the equilibrator on the mount is a critical design feature, the equilibrator force may be estimated with reasonable accuracy by assuming perfect balance and a geometry comparable to those now in use. Figure 32 is

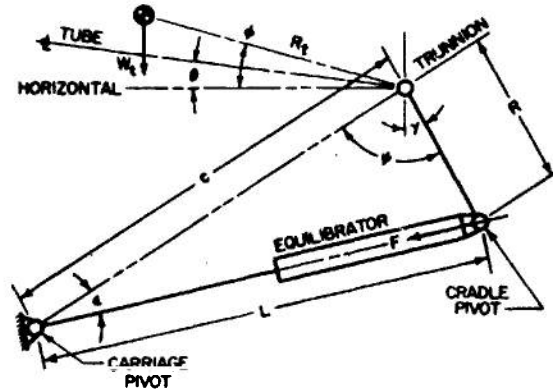

Figure 32. Equilibrator Geometry

typical. Perfect balance is achieved only with a spring equilibrator because of its constant spring rate and only if $\psi = 90^\circ$ when $\phi = 0$ (Figure 32).*

The weight moment of the tipping parts at any angle of elevation is

$$M_w = W_t R_t \cos \phi^{**} \quad (14a)$$

when $\phi = 0$

$$M_{w0} = W_t R_t^{**} \quad (14b)$$

The spring rate for each of two identical equilibrators

$$K_s = \frac{M_w}{2 c R} \dagger \quad (15)$$

*Reference 5, paragraphs 25 and 26.

** Reference 5, Equations 5 and 5a.

† Reference 5, based on Equation 14s.

Although the equilibrator force is maximum at the minimum angle of depression,† the error is small when the maximum force is assumed to be the more readily estimated value of

$$F_E = K_s L_o \quad (16)$$

where

$$L_o = \text{equilibrator length when } \phi = 0.$$

Since perfect balance is preferred, set $\psi = 90^\circ$ and $\phi = 0$, then from Figure 32

$$L_o = \sqrt{c^2 + R^2} \quad (17)$$

For preliminary estimates, let R and $R_i = 5$ calibers in length, and select a convenient value of c between R_i and R . Later, when the design of mount takes on more permanency, the dimensions may be adjusted to be more compatible with the main structure. The type of equilibrator is also subject to change. Although the initial data are for a spring equilibrator, another type, such as the hydropneumatic, may be used in the final design without involving any radical changes in the original design concept.

E. ELEVATING AND TRAVERSING GEAR LOADS

48. Estimates of the preliminary design loads which are applied to the mount through the elevating and traversing mechanism are computed according to accepted methods available in the individual handbooks on these mechanisms.†† Although these methods are accurate when the available design data are accurate, at this early stage in the design, the computed loads are only approximate because the preliminary data are approximate. One of these data is the mass moment of inertia of the tipping parts about the trunnions. For early estimates assume that the radius of gyration of the tipping parts is equivalent to that of a triangular lamina about the centroidal axis parallel to its base.

$$k_i = 0.236 L_i \quad (18)$$

where

$$L_i = \text{length of tube}$$

Assuming further that the trunnions are located two calibers forward of the breech face, and

† Reference 5, paragraph 27.

†† References 6 and 7.

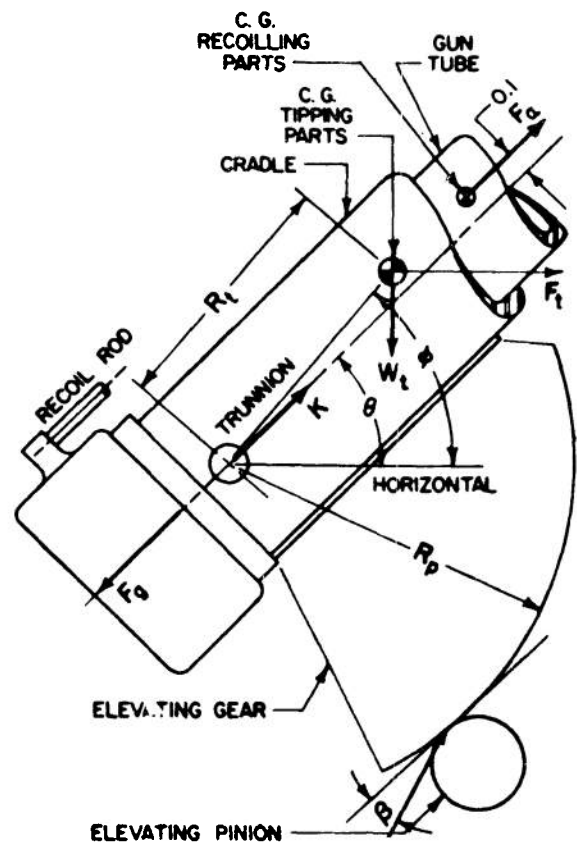

Figure 33. Elevator Gear Loading Diagram

since the centroid of the lamina is at $L_i/3$ from its base, the mass moment of inertia

$$\Phi_i = m_i [k_i^2 + (1/3 L_i - 2D_b)^2] \quad (19)$$

when

$$D_b = \text{bore diameter}$$

$$m_i = \text{mass of the tipping parts.}$$

The torque needed to accelerate the tipping parts during elevation

$$T_a = \Phi_i \alpha_e \quad (20)$$

where

$$\alpha_e = \text{elevating acceleration}$$

Figure 33 shows the preliminary design loads which affect the elevating gear load. (Note that F_0 is zero for single recoil guns). The firing torque is another component contributing to the load on

the elevating arc. A preliminary value is computed by assuming a 0.10 inch offset between trunnion and tube center of gravity. The firing torque

$$T_f = 0.10 F_a \quad (21a)$$

The general equation for the inertia force of the recoiling parts

$$F_a = F_g - K + W_r \sin \theta \quad (21b)$$

where

$$F_g = \frac{\pi}{4} D_b^2 P_g = \text{propellant, gas force}$$

$D_b =$ bore diameter

$P_g =$ propellant gas pressure

$K =$ total resistance to recoil

The total preliminary design torque of the tipping parts of a single recoil gun

$$T_e = T_a + T_f \quad (22)$$

In double recoil guns, the maximum torque applied to the elevating mechanism occurs during secondary recoil acceleration. According to Equations 31a and 21b, when $F_g = 0$,

$$T_f = 0.10 (W_r \sin \theta - k) \quad (23a)$$

The acceleration of the secondary recoiling parts

$$a_2 = \frac{K \cos \theta - W_1 \cos \theta \sin \theta - R^*}{m_2 + m_1 \sin^2 \theta} \quad (23b)$$

(See paragraphs 41 and 44 for explanation of terms.) The inertia force of the tipping parts due to secondary acceleration

$$F_t = \frac{W_t}{g} a_2 \quad (24)$$

The resulting torque (Figure 33)

$$T_t = F_t R_t \sin \phi \quad (25)$$

Finally

$$T_e = T_t + T_f \quad (26)$$

During secondary recoil deceleration, T_t and T_f are in the same direction.

Other components of torque are involved in both double and single recoil guns but these are of minor intensity and are not pertinent for preliminary design estimates. T_a and T_f appear simultaneously only if the weapon fires while elevating

or maneuvering, otherwise the larger of the two components becomes the design parameter. With T_e estimated, the tooth load on the elevating arc becomes.

$$R_e = \frac{T_e}{R_p \cos \beta} \quad (27)$$

where

$R_p =$ pitch radius of elevating arc

$\beta =$ pressure angle of gear.

49. The gear tooth load on the traversing gear (Figure 34) is determined by a similar procedure. The firing torque is assumed to be the same as that for the elevating mechanism but the accelerating torque has a much larger mass to rotate since the traversing parts include the top carriage in addition to the tipping parts. The mass moment of inertia of the traversing parts about the traversing axis

$$\Phi_{tr} = \Phi_t + \Phi_{tc} \quad (28a)$$

where

$\Phi_t =$ mass moment of inertia of tipping parts about the traversing axis. In this analysis assumed to be the same as that about the trunnions. See Equation 19.

$\Phi_{tc} =$ mass moment of inertia of top carriage about traversing axis.

For preliminary estimates, assume that the mass moment of inertia of the top carriage in terms of weight is

$$\Phi_{tc} = \frac{1}{4} W_{TC} \text{ lb-ft-sec}^2 \quad (28b)$$

The accelerating torque

$$T_a = \Phi_{tr} a_{tr} \quad (29a)$$

where

$a_{tr} =$ traversing acceleration.

The total design torque of the traversing system

$$T_{tr} = T_a + T_f \quad (29b)$$

The two components of the total torque are combined only if the gun fires while traversing. If the two never occur simultaneously, the larger is considered for design. The traversing gear tooth load

$$R_{tr} = \frac{T_{tr}}{R_p} \quad (30)$$

* Reference 2, Equation 88.

where

R_p = pitch radius of traversing gear.

F. TRUNNION BEARING AND TRAVERSING BEARING LOADS

1. Trunnion Bearing Loads

50. The recoil force is predominant on the cradle trunnion but additional force components derived from the elevating gear and the equilibrator may influence the total trunnion load to the extent of becoming significant. The equilibrator load was estimated by balancing the weight moment of the tipping parts, while the elevating gear load was

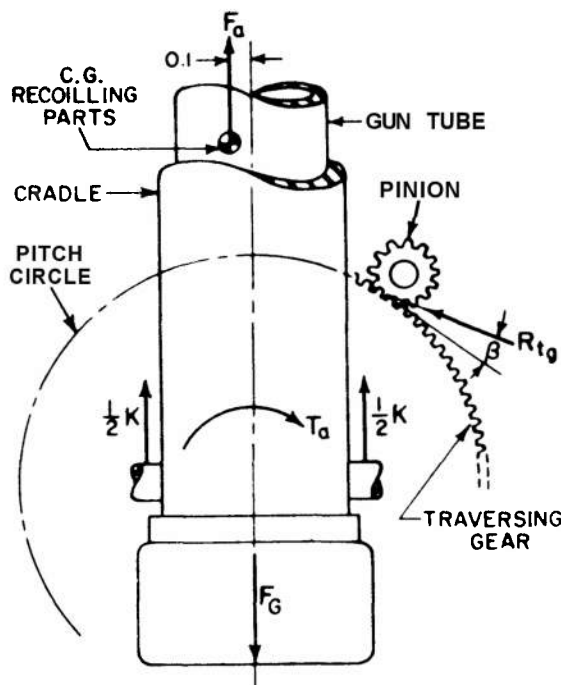

Figure 34. Traversing Gear loading Diagram

derived from balancing the firing torque, i.e., the moments produced by the inertia forces offset from the trunnions. The moments being balanced, the only values left unknown are the horizontal and vertical reactions. According to the direction of forces shown in Figure 35, the horizontal reaction

$$R_h = F_a \cos \theta + R_p \sin (\gamma - \beta) + F_E \cos \lambda - F_t \quad (31a)$$

where

F_E = equilibrator force

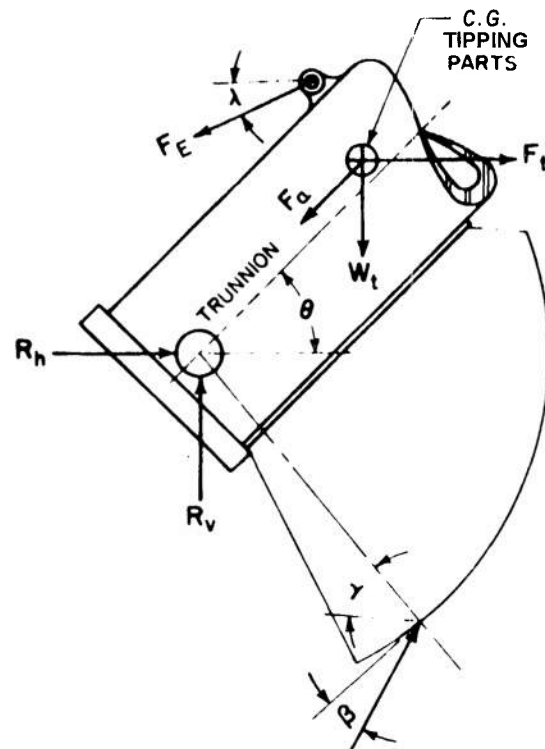

Figure 35. Trunnion Bearing Loading Diagram

F_t = inertia force of tipping parts due to secondary recoil acceleration; zero for single recoil systems

$F_a = K - W_r \sin \delta$, inertia force of recoiling parts (Eq. 6)

R_p = elevating gear tooth load

θ = angle of elevation.

The vertical reaction

$$R_v = F_a \sin \theta - R_p \cos (\gamma - \beta) + F_E \sin \lambda + W_t \quad (31b)$$

The total trunnion load becomes

$$F_T = \sqrt{R_h^2 + R_v^2} \quad (32)$$

Although the forces for the complete range of elevation must eventually be investigated to determine the maximum trunnion load, the loads at zero and maximum angle of elevation are sufficient for preliminary estimates for trunnion bearing selection.

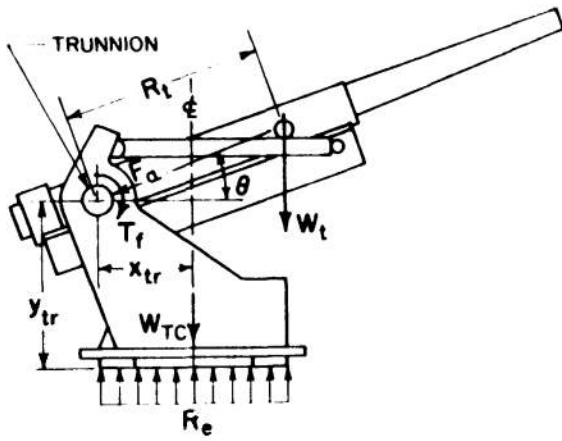

Figure 36. Traversing Bearing loading Diagram

2. Traversing Bearing Loads

51. Early estimates of traversing bearing loads are likewise based on firing at zero and maximum angles of elevation. In single recoil systems, the major externally applied loads and moments include weights of tipping parts and top carriage, the recoil force anti the firing torque (Figure 36). Taking moments about the center of the traversing bearing

$$M_{tr} = -T_f + F_a(y_{tr} \cos \theta + x_{tr} \sin \theta) - W_t(R_t \cos \theta - x_{tr}) \quad (33a)$$

where

$F_a = K - W_r \sin \delta$, inertia force of recoiling parts

T_f = firing torque (Equation 21)

W_t = weight of tipping parts.

To balance the applied moment, assume a bearing load distributed triangularly whose moment about the center

$$M_{tr} = 2R_{tb} \bar{x}_a \quad (33b)$$

where

R_{tb} = reaction on each side of the diameter

\bar{x}_a = distance from bearing center to load center

The effective load on the bearing is the load obtained by applying the maximum pressure of the triangular distribution over the entire bearing surface. The effective load is found by substitut-

ing the expressions for \bar{x}_a of Equation 19* and for R of Equation 17* into Equation 33b and solving for p , the maximum pressure. Applying p over the bearing surface, the effective pressure load is now assumed to be uniformly distributed.

$$F_e = \frac{4R_o}{R_o^2 + R_t^2} M_{tr} \quad (33c)$$

where

R_t = inside radius of bearing

R_o = outside radius of bearing.

The radii are obtained from catalogs for bearings compatible with anticipated loads and structural requirements.

The total effective load on the traversing bearing

$$R_e = F_e + \Sigma V \quad (33d)$$

$$\Sigma V = F_a \sin \theta + W_t + W_{TC} \quad (33e)$$

where

W_{TC} = weight of top carriage, assumed to be on center line of bearing.

G. APPLIED LOADS DURING TRANSPORT

52. Loads produced in carriages or mounts by accelerations during transport seldom exceed those during firing except for the local structural members to which the conveying components are attached. However, the total structure should be investigated generally to detect any critical loads which may appear while traveling. Smooth terrain offers no design problems other than side slopes which generally affect only stability. On the other hand, the effects of rough terrain on design are significant, particularly on towing structures and conveyors such as bogies and limbers. Design procedures for these three structures do not fall within the scope of the Carriages and Mounts Series of handbooks but their capacity for transmitting loads to the carriage structure is involved. The size of these loads depends on several factors including towing acceleration, speed and the type of suspension. Given load factors determine the design loads for each condition when multiplied by the weights of the various carriage components.

53. The maximum towing acceleration depends on the coefficient of friction between tires and running surface and on the weights of prime mover

* Reference 3.

and towed vehicle. During braking, the towed vehicle is assumed capable of stopping itself with its own brakes. The maximum accelerating force which the prime mover can exert is

$$F_p = \mu W_p \quad (34a)$$

where

W_p = weight of prime mover

$\mu = 0.65$, coefficient of friction of tire.

The resulting acceleration

$$a_p = \frac{F_p}{M} g = \frac{0.65 W_p}{W_p + W_w} g \quad (34b)$$

where

W_w = weight of towed weapon.

54. Since the towed unit is capable of stopping itself, the maximum acceleration during braking for both weapon and prime mover is

$$a_p = -\frac{\mu W_w}{W_w} g = -\frac{\mu W_p}{W_p} = -0.65 g \quad (34c)$$

Unless direction has special significance, the decelerating force becomes the horizontal design force. It combines with the vertical forces which

are estimated for one of four conditions involving transportation over level but rough terrain.

Load factors for a sprung chassis

1. 3.0 g 's for maximum speeds of less than 30 mph

2. 5.0 g 's for maximum speeds of 30 or more mph

Load factors for unsprung chassis

3. 5.0 g 's for maximum speeds of less than 30 mph

4. 12.0 g 's for maximum speeds of 30 or more mph

55. The weapon must be capable of being transported along a side slope of 30% without overloading any of its structural components. Such a steep slope must be negotiated at slow speeds to preserve stability and hence, a load factor of 1.0 g seems reasonable. Local areas near attachments may be critically loaded and should be investigated for side loads but the general carriage structure will not suffer under the same conditions. Other than from a stability viewpoint, the side slope condition does not influence preliminary design.

CHAPTER 6

SIZE OF STRUCTURE

A. TRUNNION HEIGHT

56. Required ground clearance at the end of recoil when firing at maximum elevation establishes the trunnion height and hence, the height of weapon. After the preliminary length of recoil has been found (Equation 7c), the trunnion height may be computed by allowing a length of three calibers which is ample for the distance between trunnion and rear of breech ring. Adopting such a measure quickly establishes the preliminary trunnion height of

$$y_T = (L + 3D_b) \sin \theta_m \quad (35a)$$

where

- D_b = bore diameter
- L = length of recoil
- θ_m = maximum angle of elevation.

B. STABILITY EFFECTS OF STRUCTURAL SIZE

57. Under ordinary circumstances, a weapon should be stable at all times, whether firing or in transport. During transport, stability is seldom a vital design factor except for the side slope condi-

tion which specifies stability while moving along a 30% slope. According to Figure 37, stability is achieved when the center of gravity lies inside the wheel span, i.e., when the span

$$L_t = 2h \tan \phi \quad (35b)$$

where

- h = distance of CG above ground
- $\tan \phi = 0.30$, maximum side slope

Thus a symmetrical transverse distribution of weight and a low center of gravity rather than the actual weight are the criteria for stability during transport. The 30% side slope is a limiting design

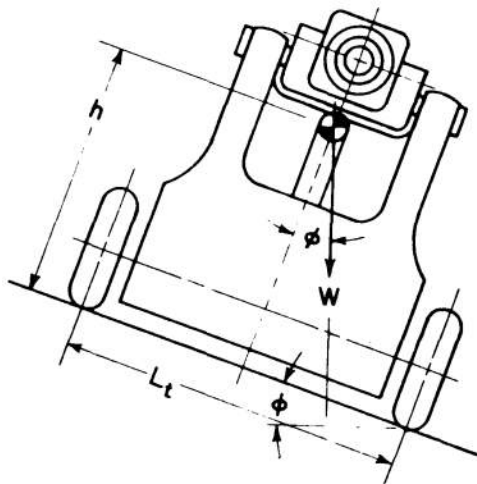

Figure 37. Side Slope Stability

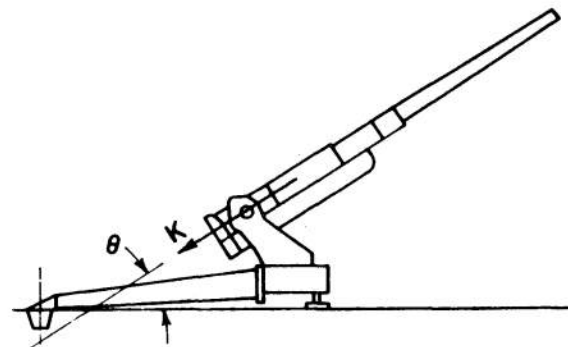

Figure 38. Stability by Inspection—Single Recoil System

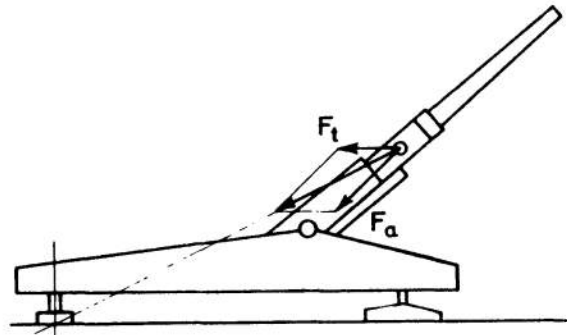

Figure 39. Stability by Inspection—Double Recoil System

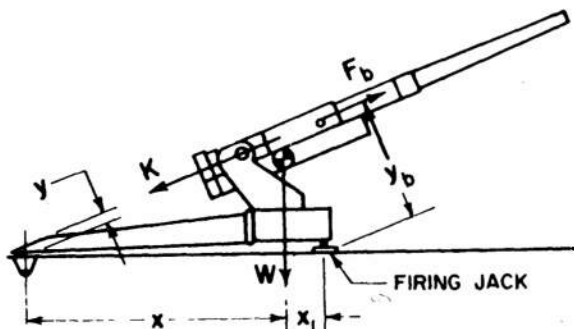

Figure 40. Stability During Firing—Single Recoil System

condition. A value of $\tan \phi$ greater than 0.30 is necessary to assure stability on this slope.

58. On the other hand, weight contributes appreciably to the stability of a weapon when firing, particularly at low angles of elevation. Stability may be checked by inspection. The weapon is stable if the resultant of the recoil forces intersects the ground within the outer limits of the supports (Figure 38); the ends of trails or outrigger of single recoil types, or the rear support of double recoil type carriages (Figure 39). If the angle δf

elevation is low enough for the resultant to intersect the ground outside the rear supports, stability is checked by computing moments about the intersection of rear support and ground. In Figure 40, stability is assured during recoil when $F_b = 0$, if

$$W_x \leq K_y \quad (35c)$$

Similarly, during buffing, when $K = 0$, stability is achieved when

$$W_{xt} = F_b y_b \quad (35d)$$

During recoil if $K_y > W_x$, the front support will leave the ground and the tube will move from its aimed position, thereby inducing some inaccuracy. This movement is "jump." Most of the displacement occurs after the projectile leaves the muzzle, but "jump" is still objectionable because it gradually changes the gun's position. Improved stability may be achieved by increasing the distance between rear support and center of gravity. However, when further extension becomes impractical, minimum angle of elevation must be compromised to satisfy the limiting stability conditions.

59. The stability during recoil of double recoil guns becomes most critical after propellant gas

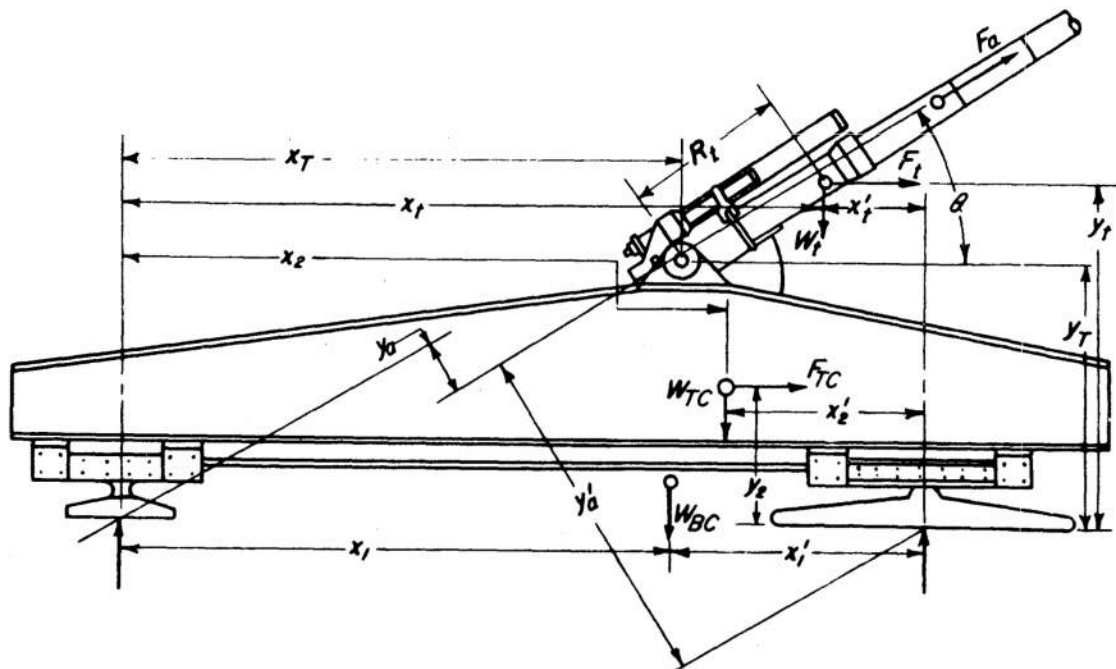

Figure 47. Stability During Firing—Double Recoil System

pressures are no longer effective and when both primary and secondary recoiling masses are decelerating simultaneously. With the forces and dimensions in Figure 41 shown positive, a stable weapon is assured when

$$x_1 W_t + x_2 W_{TC} + x_1 W_{BC} \geq y_a F_a - y_2 F_{TC} - y_t F_t \quad (35e)$$

where

F_a = inertia force of primary parts induced by primary acceleration

F_t = inertia force of tipping parts induced by secondary acceleration

F_{TC} = inertia force of top carriage induced by secondary acceleration

W_{BC} = weight of bottom carriage

W_{TC} = weight of top carriage

W_t = weight of tipping parts

Forces which do not appear in Equation 35e have diminished to zero by the time the present condition prevails.

60. Stability also becomes a problem during counterrecoil, especially during buffing when prevailing forces tending to nose over the weapon are maximum. Although not as critical as during recoil, since projectile flight is not disturbed, a disturbance of this nature may shift the original position of carriage or mount to displace the aiming reference. Rapid fire, single recoil guns need a longer firing base for buffing stability since counterrecoil must be rapid, and with more energy to be absorbed over a short distance, buffer forces are correspondingly higher. But, since these guns have

pedestal mounts equipped with four outriggers equally spaced, stability is assured for 360° of traverse. With recoil forces being larger than buffing forces and with a virtually symmetrical firing base, stability during buffing is also assured.

61. Stability of double recoil weapons during counterrecoil generally includes two conditions. The first occurs during buffing of the primary system while the secondary system is still recoiling or is in the process of counterrecoiling. In either event, the inertia force of the secondary recoiling mass is opposite to that of the primary mass and therefore helps to balance the nosing over moment. The first condition is seldom critical but should be investigated. The second condition occurs during buffing of the secondary recoiling mass, with the primary parts fully returned to battery. The weapon will be stable when, in Figure 41, the moments about the front support

$$x_1' W_t + x_2' W_{TC} + x_1' W_{BC} \geq y_a' F_b + y_t' F_{t2} + y_2' F_{T2} \quad (35f)$$

where

F_b = inertia force of primary parts induced by primary buffing

F_{t2} = inertia force of tipping parts induced by secondary buffing

F_{T2} = inertia force of top carriage induced by secondary buffing

The inertia forces F_a , F_t and F_{TC} are general terms shown positive in Figure 41. During buffing, these terms are replaced, respectively by F_b , F_{t2} and F_{T2} .

CHAPTER 7

PRELIMINARY DESIGN PROCEDURES FOR MORTAR MOUNTS

A. STRUCTURAL COMPONENTS

62. A mortar is basically a short-tubed, light-weight weapon capable of firing at very high elevations with low muzzle velocities. This velocity-elevation combination offers the advantage of being able to reach nearby targets and to clear high barriers that shelter these targets from direct fire. The weapon consists of three primary components: the tube assembly (mortar), the mount, and the base plate which are shown in Figure 42. Base

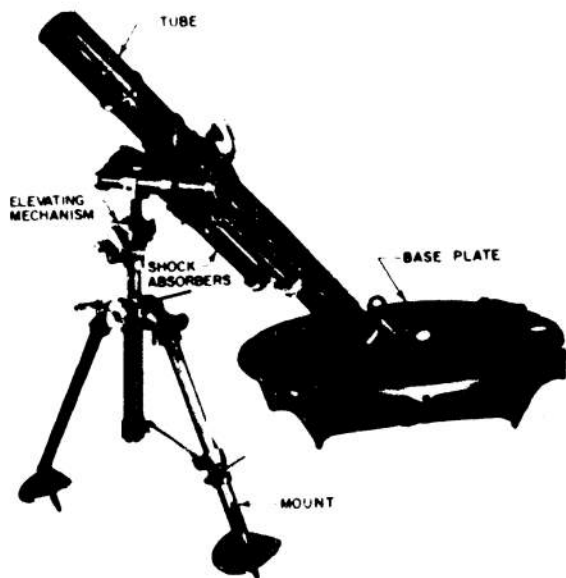
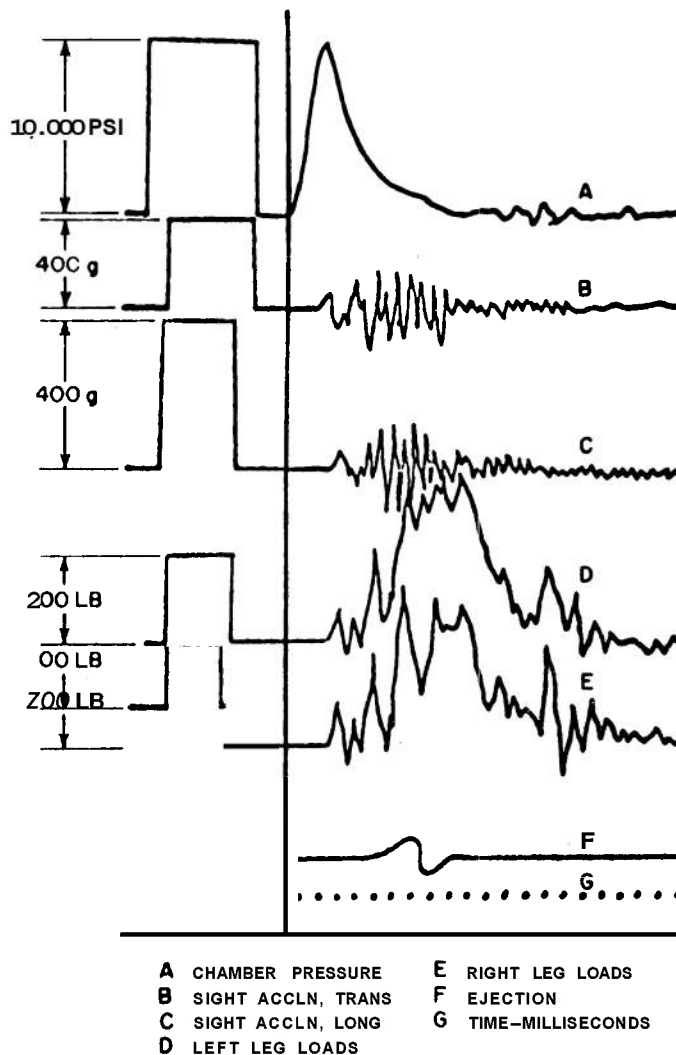

Figure 42. Mortar

plate and mount support and position the tube during firing. Each component is essentially a simple structure, readily attachable to the others, thereby providing for quick emplacement and dis-
 emplacement.

63. Lightness is the fundamental design criterion which renders mortars portable, thereby providing the infantry with large caliber weapons. To be readily portable by one man, each major weapon

component, base, mount, or tube assembly, should not weigh more than 25 pounds. If the tube is much heavier, it may be long enough for two men to carry. Heavier components may still be portable but longer periods of time will be required to reach the area of emplacement.



- | | |
|----------------------|---------------------|
| A CHAMBER PRESSURE | E RIGHT LEG LOADS |
| B SIGHT ACCLN, TRANS | F EJECTION |
| C SIGHT ACCLN, LONG | G TIME-MILLISECONDS |
| D LEFT LEG LOADS | |

Figure 43. Typical firing Data

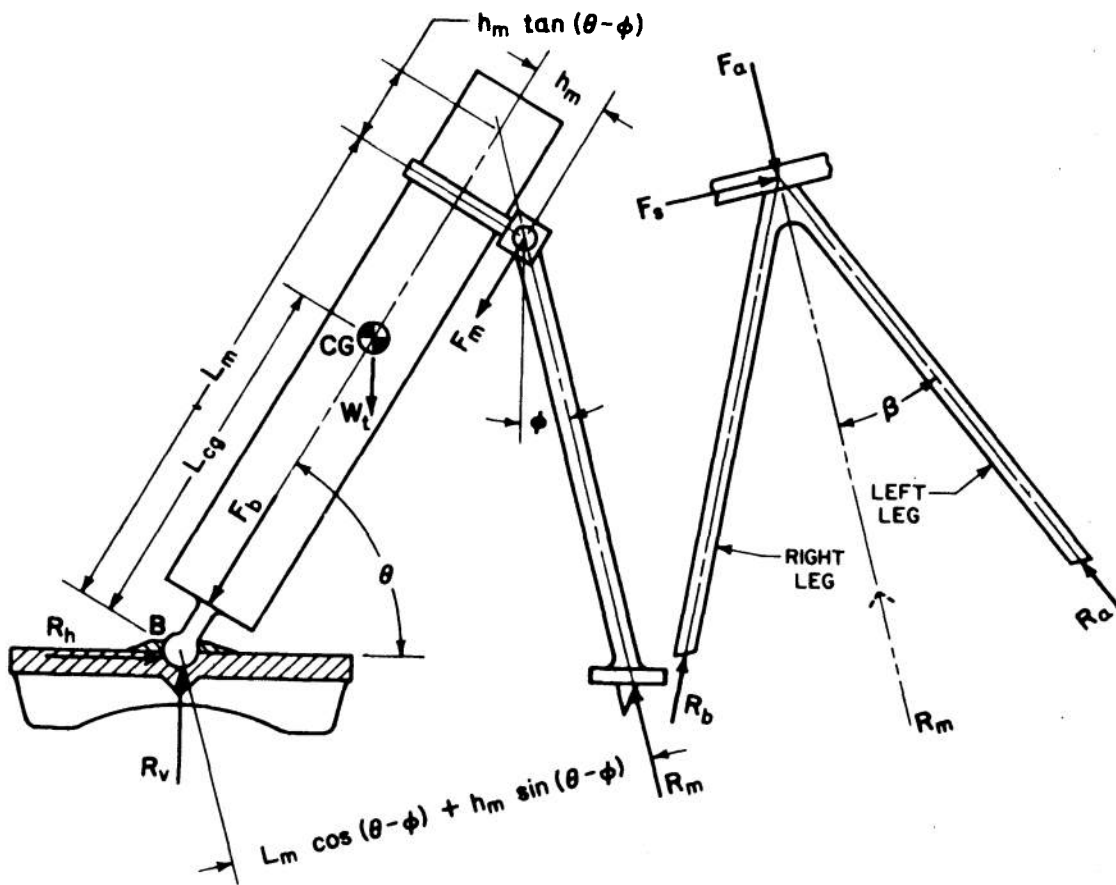

Figure 44. loading Diagram of Mortar

B. MOUNT

64. The mount is the stabilizing and positioning component of the weapon. It supports the elevating and traversing mechanisms and the sight. Both elevating and traversing mechanisms are generally of the screw and nut type. Elevation ranges from 45 to 85 degrees whereas traverse is limited to about ± 5 degrees. Direct support of the tube is achieved through a flexible linkage comprised of one or two shock absorbers mounted parallel to the bore. The piston rod of the shock absorber is clamped to the tube; the cylinder is attached to the mount to permit motion between tube and mount. This motion moderates the shock of recoil on the mount by absorbing the energy of vibration. Under the influence of the shock absorbers, the acceleration induced on the mount is reduced to

20% to 35% of the recoil acceleration. Thus

$$0.20 a_r \leq a_m \leq 0.35 a_r \quad (36)$$

where

$$\begin{aligned} a_m &= \text{mount acceleration} \\ a_r &= \text{recoil acceleration} \end{aligned}$$

The limits of Equation 36 are substantiated by test results similar to those of Figure 43.

65. To obtain static loading conditions, the mass center of the mount is conservatively assumed to be located at the tube attachment. Figure 44 shows the loads, reactions and the dimensions pertinent to the loading analysis. The symbols appearing in the analysis are defined

$$\begin{aligned} A_b &= \text{bore area} \\ F_a &= \text{inertia force on mount in plane of mount} \end{aligned}$$

- F'_b = residual accelerating force on base cap
- F'_{ga} = average propellant gas force
- F'_{gm} = maximum propellant gas force
- F'_m = inertia load of mount applied to tube
- F'_s = side load on mount induced by transverse acceleration
- h_m = distance from mount attachment to bore center line
- L_{cp} = distance from base plate socket to mass center of tube
- L_m = distance from base plate socket to mount attachment
- P_{ga} = average propellant gas pressure
- P_{gm} = maximum propellant gas pressure
- R_a = axial load in left leg
- R_b = axial load in right leg
- R_h = horizontal reaction on base plate
- R_m = reaction on mount in elevation plane
- R_v = vertical reaction on base plate
- W_b = weight of base plate
- W_m = weight of mount
- W_t = weight of tube assembly
- θ = angle of elevation
- ϕ = angle between mount and the vertical in elevation plane

$$M_u = W_t L_{cp} \cos \theta + F'_m h_m - R_m [L_m \cos (\theta - \phi) + h_m \sin (\theta - \phi)] = 0 \quad (38a)$$

$$R_m = \frac{W_t L_{cp} \cos \theta + F'_m h_m}{L_m \cos (\theta - \phi) + h_m \sin (\theta - \phi)} \quad (38b)$$

A bipod mount will have components of the ground reaction distributed to each of the two legs. Since appreciable transverse accelerations are present (Figure 43) the legs are not loaded equally.

All the information needed to compute the loads and reactions are available except for recoil acceleration which determines the inertial load of the mount. An approximate acceleration can be obtained from the average propellant gas force and the known or estimated weight of tube assembly and base. The average propellant gas force

$$F'_{ga} = P_{ga} A_b \quad (37a)$$

The average recoil acceleration

$$a_r = \frac{F'_{ga}}{W_b + W_t} \quad (37b)$$

After obtaining the limits of mount, acceleration from Equation 36, compute the mount inertial force

$$F'_m = \frac{W_m}{g} a_m \quad (37c)$$

66. The ground reaction on the mount becomes available by balancing the moments from Figure 44. Equating the moments about **B** to zero

Furthermore, the right leg cannot be loaded when $F'_s \leq F'_a \tan \beta$, a condition which becomes obvious by inspecting Figure 44. When F'_s exceeds $F'_a \tan \beta$, a balanced system demands that the right leg be put in tension. However, since it merely rests on the ground, tension cannot exist in this member

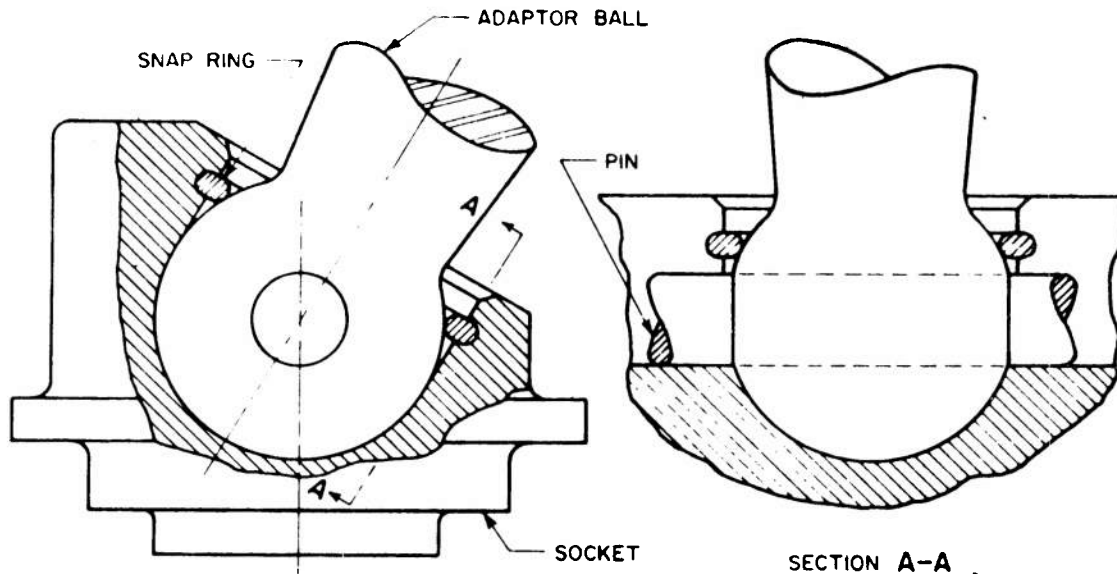

Figure 45. Pinned Ball and Socket Joint

hence a static condition no longer prevails. The residual side load in this case has a tendency to tilt the weapon. The rapid periodic change in direction of the transverse acceleration prevents the weapon from falling. On this basis, the assumption can be made that one leg of a bipod should be capable of supporting the entire vertical load. Thus, the maximum axial load in the leg

$$R_a = \frac{F_a}{\cos \phi} \quad (38c)$$

where

$$F_a = -R_m$$

ϕ varies from 30° to 40°.

R_a completes the design data needed for the stress analysis of the mount structure which may be computed by established procedures for columns.

$$R_v = W_b + W_t + (F_b + F_m) \sin \theta - R_m \cos \phi \quad (39a)$$

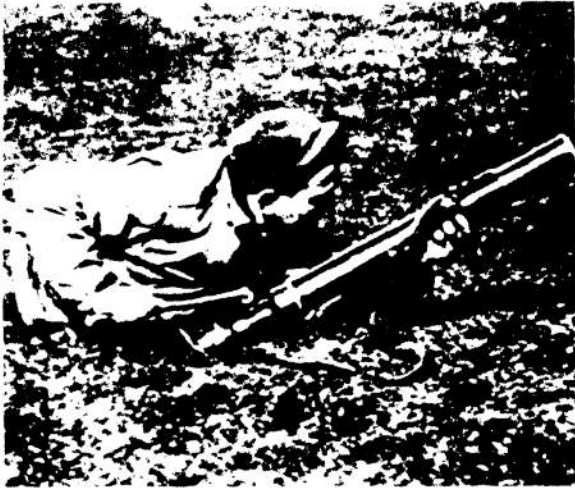

Figure 46. Hand-held Mortar

C. BASE PLATE

66. Base plate and tube are connected by a ball and socket joint. The ball of the adapter base cap rests in the socket located in the center of the base plate and is retained by a snap ring. On some arrangements, the ball has a pin which passes through it on a transverse diameter and enters into corresponding slots in the socket. This arrangement which permits elevating rotation between adapter ball and socket, and azimuth rotation between socket and base plate is schematically illustrated in Figure 45.

67. The base plate transmits most of the firing load from the tube to the ground. The components of these loads are found by completing the static load distribution of Figure 44. The vertical reaction

The horizontal reaction on the spades

$$R_h = (F_b + F_m) \cos \theta + R_m \sin \phi \quad (39b)$$

Although base plates have been made rectangular and may still be useful for hand-supported firing (Figure 46), the trend is toward circular construction. The size of the contacting surfaces is determined from an allowable ground pressure of 190 psi. For a circular base,

$$P_a = \frac{R_v}{\pi r_b^2} \leq 190 \text{ lb/in}^2 \quad (40a)$$

where

r_b = radius of base, in.

The spade area is determined from an allowable maximum ground pressure of 770 psi although one of 500 psi is more desirable

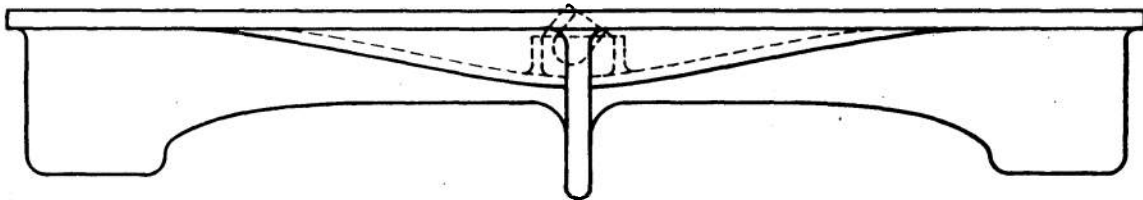

Figure 47. Base Plate With Spades

$$P_s = \frac{R_s}{A_s} \gtrsim 770 \text{ lb/in}^2 \quad (40b)$$

where

A_s = total projected spade area in direction of R_s .

68. No analytic procedure has been established to determine the thickness of top plate and spades

nor the shape of spades. The design is decidedly empirical in approach. Forged aluminum alloy base plates have top plates ranging from $\frac{1}{4}$ to $\frac{5}{8}$ inch thick. Ribs and spades range from $\frac{1}{2}$ to 1 inch thick. The shape of spades is usually patterned after those which have been used successfully, an example is sketched in Figure 47. Find acceptance always depends on experimental firings.

CHAPTER 8

SAMPLE CALCULATIONS

A. WEIGHT ESTIMATES

A 165 mm gun is selected as the hypothetical weapon to illustrate the procedures involved in finding the preliminary design data needed for its carriage and associated components. The given data

- $D_b = 6.5$ in., bore diameter (165 mm)
- $P_p = 45,000$ lb/in², maximum propellant gas pressure
- $v_m = 2850$ ft/sec, muzzle velocity
- $W_p = 126$ lb, weight of projectile
- $W_g = 37$ lb, weight of propellant gas
- $\theta = 65^\circ$, maximum angle of elevation.

According to Equation 1, the muzzle energy

$$E_m = \frac{1}{2} M_p v_m^2 = \frac{1}{2} \times \frac{126}{32.2} 2850^2 = 15,900,000 \text{ ft-lb}$$

From Equation 3, the minimum weight of the recoiling parts

$$W_r = 8.2 \times 10^{-4} E_m = 13,000 \text{ lb}$$

From Equation 4, the minimum weight of the emplaced weapon

$$W = 22.8 \times 10^{-4} E_m = 36,200 \text{ lb}$$

Weights assigned to other components are based on proportions generally found applicable to the type weapon. For the single recoil gun

- $W_{TC} = 10,000$ lb, weight of top carriage
- $W_{BC} = 8,800$ lb, weight of bottom carriage, including trails.

For the double recoil weapon

$$W_{TC} = 19,500 \text{ lb, weight of top carriage, in-}$$

cluding the cradle and other secondary recoiling parts

$$W_{BC} = W - W_{TC} - W_r = 3,700 \text{ lb, weight of bottom carriage.}$$

B. PRELIMINARY RECOIL CHARACTERISTICS

1. Single Recoil System

Both weights represent minimal values which recognizes design philosophy of minimum structural weights. These weights are assigned to single or double recoil type weapons. Equation 5a provides the velocity of free recoil

$$v_r = \frac{W_p v_m + 4700 W_g}{W_r} = \frac{126 \times 2850 + 4700 \times 37}{13,000} = 41 \text{ ft/sec}$$

From Equation 5b, the energy of free recoil

$$E_r = \frac{1}{2} M_r v_r^2 = \frac{1}{2} \times \frac{13,000}{32.2} \times 41^2 = 339,000 \text{ ft-lb}$$

The length of recoil, according to Equation 7

$$L = 10 D_b = 10 \times 6.5 = 65 \text{ in}$$

Based on this distance, the recoil force, according to Equation 6

$$K = \frac{E_r}{L} + W_r \sin \theta = \frac{339,000}{5.42} + 13,000 \times 0.906 = 74,300 \text{ lb}$$

2. Double Recoil System

For a double recoil weapon, assume a primary recoil stroke of 65 in., the same as for the single recoil weapon and a secondary recoil stroke of 4 ft. According to Equation 9, the primary recoil resistance

$$K = \frac{m_1 v_r^2}{2L_1} \left(1 - \frac{L_2 \cos^2 \theta}{L_1 \cos \theta + L_2 \frac{m_1 + m_2}{m_1}} \right) + W_1 \sin \theta$$

$$K = \frac{13,000 \times 41^2}{64.4 \times 5.42} \left(1 - \frac{4 \times 0.423^2}{5.42 \times 0.423 + 4 \times 2.5} \right) + 13,000 \times 0.906 = 62,500 \times 0.942 + 11,800 = 70,600$$

where, according to Equation 8

$$\frac{m_1 + m_2}{m_1} = 2.5$$

The suggested angle of elevation for computing the secondary recoil force is 20". From Equation 10, this force

$$R = \frac{\frac{1}{2} m_1 v_f^2 \cos^2 \theta}{L_1 \cos \theta + L_2 \frac{m_1 + m_2}{m_1}} = \frac{339,000 \times 0.94^2}{5.42 \times 0.94 + 4 \times 2.5} = 19,900 \text{ lb}$$

On the surface, the difference in recoil forces between single and the primary recoil force of double recoil systems is slight but past experience has shown that for similar weights, the double recoil weapon can sustain greater loads and, therefore, can tolerate a shorter recoil stroke which in turn tends towards a lower silhouette. The large contrast between single and double recoil systems is in the horizontal loads which becomes evident at horizontal firing where the spade reaction for the single recoil weapon is 62,500 lb while for the double recoil weapon, according to Equation 10 when θ equals zero, it is only 22,000 lb.

C. EQUILIBRATOR FORCE

Paragraph 47 deals with equilibrator parameters which are obtained from Equations 13b to 17. The weight of the tipping parts

$$W_t = \frac{1}{3} W = \frac{1}{3} \times 13,000 = 17,300 \text{ lb}$$

Conforming to the geometry suggested in paragraph 47

$$R_t = R = 5 D_b = 32.5 \text{ in.}$$

$$c = 2 R = 65 \text{ in. (First trial value, see paragraph 47.)}$$

$$L_o = \sqrt{65^2 + 32.5^2} = 72.7 \text{ in.}$$

The weight moment from Equation 14b

$$M_{wo} = W_t R_t = 31.5 \times 17,300 = 562,000 \text{ lb-in}$$

The spring rate, for each of two equilibrators, according to Equation 15

$$K_s = \frac{M_{wo}}{2cR} = \frac{562,000}{2 \times 65 \times 32.5} = 133 \text{ lb/in}$$

The maximum force for two equilibrators, according to Equation 16

$$F_E = K_s L_o = 2 \times 133 \times 72.7 = 19,400 \text{ lb}$$

If a pneumatic or hydropneumatic equilibrator is desired, its maximum operating pressure determines the piston area to conform with the maximum force.

D. ELEVATING AND TRAVERSING LOADS

1. Elevating Gear Load

To estimate the elevating gear load, assume a tube length of 45 calibers. Other assumed parameters which appear practical are

$$R_p = 38 \text{ in., pitch radius of elevating gear}$$

$$\alpha_e = 0.15 \text{ rad/sec}^2, \text{ elevating acceleration}$$

$$\beta = 20^\circ, \text{ gear pressure angle}$$

$$L_t = 45 D_b = 292 \text{ in.}$$

According to Equation 18, the radius of gyration

$$k_t = 0.236 L_t = 0.236 \times 292 = 69 \text{ in}$$

The mass moment of inertia by virtue of Equation 19

$$\begin{aligned} \Phi_t &= m_t [k_t^2 + (\frac{1}{3} L_t - 2D_b)^2] \\ &= \frac{17,300}{12 \times 32.2} [69^2 + (97.3 - 13)^2] \\ &= 531,000 \text{ lb-in-sec}^2 \end{aligned}$$

From Equation 20

$$T_a = \Phi_t \alpha_e = 0.15 \times 531,000 = 79,800 \text{ lb-in}$$

From Equation 21b

$$F_g = \frac{\pi}{4} D_b^2 P_g = \frac{4}{\pi} \times 6.5^2 \times 45,000 = 1,493,000 \text{ lb}$$

From Equation 21b

$$\begin{aligned} F_a &= F_g - K + W_t \sin \theta \\ &= 1,493,000 - 74,300 + 11,800 \\ &= 1,430,500 \text{ lb} \end{aligned}$$

$$T_f = 0.10 F_a = 143,000 \text{ lb-in}$$

Since the gun does not elevate while firing, T_f becomes the maximum torque, therefore Equation 27 provides the preliminary gear tooth design load

$$R = \frac{T_e}{R_p \cos \beta} = \frac{143,000}{38 \times 0.94} = 4,000 \text{ lb}$$

For a double recoil weapon, the effects of secondary recoil acceleration must be investigated. As T_a and T_f do not appear simultaneously and since secondary acceleration appears after pro-

pellant gas force cease, Equation 21a involves only the primary recoil inertia force, therefore,

$$T_f = 0.10 F_a = 0.10 \times 58,800 = 5,880 \text{ lb-in}$$

$$a_2 = \frac{70,600 \times 0.423 - 13,000 \times 0.423 \times 0.906 - 19,900}{19,500 + 13,000 \times 0.906^2} - \frac{5000}{30,200} = 0.162 g's$$

Based on Equation 24, the inertia force of the tipping parts

$$F_t = W_t a_2 = 17,300 \times 0.162 = 2,800 \text{ lb}$$

In Equation 25, $\phi = 70^\circ$ with the resulting torque

$$T_t = F_t R_t \sin \phi = 2,800 \times 32.5 \times 0.94 = 85,500 \text{ lb-in}$$

From Equation 26

$$T_e = T_t + T_f = 85,500 + 5,880 = 91,380 \text{ lb-in}$$

From Equation 27

$$R = \frac{T_e}{R_p \cos \beta} = \frac{91,380}{38 \times 0.94} = 2,560 \text{ lb}$$

This load is less than that produced by the firing torque which remains as the design condition for the elevating gear.

2. Traversing Gear Load

For the traversing gear load analyses, the pitch radius and angular acceleration for the single recoil weapon are assumed to be, respectively,

$$R_p = 40 \text{ in.}$$

$$\alpha_{tr} = 0.15 \text{ rad/sec}^2$$

Now, according to Equations 28a to 30 inclusive,

$$\Phi_{tc} = \frac{1}{4} W_{TC} = \frac{10,000}{4} \times 12 = 30,000 \text{ lb-in-sec}^2$$

where the top carriage unit is assumed to weigh 10,000 lb

$$\Phi = \Phi_t + \Phi_{tc} = 531,000 + 30,000 = 561,000 \text{ lb-in-sec}^2$$

$$T_a = \Phi_{tr} \alpha_{tr} = 0.15 \times 561,000 = 84,100 \text{ lb-in}$$

The firing torque, $T_f = 143,000 \text{ lb-in}$, is also assumed to apply to the traversing unit and, since it has the larger value, it becomes the design loading. The traversing gear tooth load

$$R_{tg} = \frac{143,000}{40} = 3580 \text{ lb.}$$

Equation 23 when an angle of elevation $\theta = 65^\circ$

$$a_2 = \frac{K \cos 8 - W_1 \cos \theta \sin 8 - R}{W_2 + W_1 \sin^2 8}$$

E. TRUNNION BEARING AND TRAVERSING BEARING LOADS

1. Trunnion Bearing Load

To determine the trunnion bearing loads the assigned values to the angles and loads of Figure 35 for the single recoil weapon are

$$\begin{aligned} \beta &= 20^\circ & F_B &= 19,400 \text{ lb} \\ \gamma &= 60^\circ & F_t &= 0 \\ e &= 65^\circ & F_a &= 62,500 \text{ lb} \\ \lambda &= 25^\circ & R_p &= 4,000 \text{ lb} \end{aligned}$$

The horizontal reaction of the trunnion, according to Equation 31a

$$\begin{aligned} R_h &= F_a \cos 8 - R \sin (\gamma - \beta) + F_B \cos \lambda - F_t \\ &= 26,500 - 2,600 + 17,600 - 0 = 41,500 \text{ lb} \end{aligned}$$

From Equation 31b, the vertical reaction

$$\begin{aligned} R_v &= F_a \sin \theta - R_p \cos (\gamma - \beta) + F_B \sin \lambda + W_t \\ &= 56,600 - 3,100 + 8,200 + 17,300 \\ &= 79,000 \text{ lb} \end{aligned}$$

The total trunnion load as computed from Equation 32

$$F_T = \sqrt{R_h^2 + R_v^2} = 89,300 \text{ lb}$$

2. Traversing Bearing Load

The traverse bearing design load is based on the maximum loading conditions. This happens with a negative firing torque and where

$$\tan 8 = \frac{x_{tr}}{y_{tr}}$$

The values in paragraph 51 assigned for this analysis are

$$\begin{aligned} K &= 74,300 \text{ lb} & T_f &= 143,000 \text{ lb-in} \\ R_t &= 32.5 \text{ in} & W_t &= 17,300 \text{ lb} \\ R_i &= 12 \text{ in} & x_{tr} &= 18 \text{ in} \\ R_o &= 14 \text{ in} & y_{tr} &= 48 \text{ in} \\ \tan \theta &= \frac{1}{4} = 0.375 & \theta &= 20^\circ 33' \end{aligned}$$

Based on Equation 6-

$$F_a = K - W_r \sin \theta = 74,300 - 4,600 = 69,700 \text{ lb}$$

Equation 33a has

$$M_{tr} = -T_f + F_a(y_{tr} \cos \theta + x_{tr} \sin \theta) - W_t(R_t \cos \theta - x_{tr})$$

$$F = \frac{4R_o}{R_o^2 + R_t^2} M_{tr} = \frac{4 \times 14}{340} 3,498,000 = 576,000 \text{ lb}$$

The total effective load on the traversing bearing obtained from Equations 33d and 33e

$$\begin{aligned} R_s &= F_r + F_a \sin \theta + W_t + W_{TC} \\ &= 576,000 + 24,400 + 17,300 + 10,000 \\ &= 627,700 \text{ lb} \end{aligned}$$

The task remaining in the selection of bearing, the roller type being recommended, which will support the trunnion and traversing bearing loads. Sizes and load capacities are available in commercial catalogs. Practice permits 100 percent overloads for firing conditions, therefore a bearing with a static rating of 314,000 lb would be adequate.

F. SIZE OF STRUCTURE

1. Trunnion Height

Equation 35a establishes the preliminary trunnion height as

$$\begin{aligned} y_T &= (L + 3D_b) \sin \theta_m \\ &= (65 + 3 \times 6.5) \sin 65^\circ \\ &= 84.5 \times 0.906 = 76.5 \text{ in.} \end{aligned}$$

2. Stability

The weapon is stabilized by locating the vertical ground reaction with respect to the center of gravity. For the single recoil weapon, assume horizontal firing. Thus in Equations 35e and 35f

$$\begin{aligned} y &= y_b = y_T = 76.5 \text{ in.} \\ W &= 36,200 \text{ lb} \\ K &= 74,300 \text{ lb} \end{aligned}$$

The projected length of the replaced trail in the vertical plane of the tube is obtained from Equation 35e by solving for x

$$x = \frac{Ky_T}{W} = \frac{74,300 \times 76.5}{36,200} = 157 \text{ in.}$$

If this length is considered too long, the weapon must be restricted to a minimum angle of elevation larger than zero if weapon jump is to be precluded.

$$\begin{aligned} &= 143,000 + 69,700(44.9 + 6.32) \\ &\quad - 17,300(30.4 - 18) \\ &= 143,000 + 3,570,000 - 215,000 \\ &= 3,498,000 \text{ lb-in} \end{aligned}$$

According to Equation 33e, the effective pressure load

Nosing-over tendencies prevail during buffing, the latter part of the counterrecoil stroke. Early estimates has the buffer stroke equal to 25% of the recoil stroke (paragraph 45)

$$x_b = 0.25 \times 65 \frac{1}{2} = 1.355 \text{ ft}$$

Assuming a counterrecoil velocity of 5 ft per sec, the buffing force from Equation 11

$$F_b = \frac{M_r v_{cr}^2}{2x_b} = \frac{13,000 \times 25}{2 \times 32.2 \times 1.355} = 3,720 \text{ lb}$$

The horizontal distance between front, support and center of gravity of the weapon to balance it during counterrecoil is computed from Equation 35d

$$x_1 = \frac{F_b y_b}{W} = \frac{3,720 \times 76.5}{36,200} = 7.77 \text{ in.}$$

The stability of a double recoil weapon depends on secondary recoil characteristics in addition to the locations of ground supports, trunnions, and center of gravity. Tentative locations are estimated first for firing at zero elevation. Later, when design data is complete for the entire recoil cycle, the critical elevation may be lower. The assigned data are

$$\begin{aligned} K &= 70,600 \text{ lb} & W_r &= 13,000 \text{ lb} \\ R &= 19,900 \text{ lb} & W_t &= 17,300 \text{ lb} \\ W &= 36,200 \text{ lb} & W_{TC} &= 19,500 \text{ lb} \end{aligned}$$

According to Equation 35a, preliminary trunnion heights of single and double recoil guns are equal. Assume that the mass center of the top carriage is at half the trunnion height and, from experience, within two calibers rearward of the front support. Also the center of gravity of the bottom carriage is at the same horizontal location as the top carriage. Because the effect of the resistance to secondary recoil must be considered, the location of the center of gravity of the weapon is found by a modified version of Equation 35e

$$x = \frac{Ky_T + \frac{1}{2} Ry_T}{W} = \frac{70,600 \times 76.5 + 19,900 \times 38.25}{36,200} = \frac{6,162,000}{36,200} = 170 \text{ in.}$$

The values assigned to the secondary buffer are

$$x_{b2} = 1.0 \text{ ft}$$

$$v_{cr2} = 4 \text{ ft per sec}$$

The total secondary buffing force according to Equation 12a

$$F_{b2} = \frac{(m_1 + m_2)}{2x_{b2}} v_{cr2}^2 = \frac{1010}{2 \times 1.0} \times 4^2 = 8,100 \text{ lb}$$

From Equations 12b and 12c the inertial forces of the primary and secondary recoiling parts due to secondary buffing

$$F_{t2} = \frac{m_1}{m_1 + m_2} F_{b2} = \frac{1}{2.5} \times 8100 = 3,200 \text{ lb}$$

$$F_{T2} = \frac{m_2}{m_1 + m_2} F_{b2} = \frac{1.5}{2.5} \times 8100 = 4,900 \text{ lb}$$

The critical forward tipping action occurs at maximum elevation. The location of the weapon center of gravity from the front support

$$x' = \frac{F_{t2}(y_T + R_t \sin \theta) + \frac{1}{2} F_{T2} y_T}{W}$$

$$\frac{3280 \times 105.9 + 4920 \times 38.25}{36,700}$$

$$= \frac{535,000}{36,700} = 14.6 \text{ in.}$$

The farthest forward location of the trunnions with respect to the front support to insure stability during secondary buffing is found by balancing the weight moments of the components with that of the total weight about the front support.

$$x_2' = 2D_b = 2 \times 6.5 = 13 \text{ in.}$$

$$(W - W_t) x_2' - (R_t \cos 65^\circ - x_T') W_t = W x'$$

$$19,100 \times 13 - 13.75 \times 17,600 + 17,600 x_T'$$

$$= 536,000$$

$$17,600 x_T' = 530,000$$

$$x_T' = 30.1$$

the trunnion distance to the rear of the front support. The actual location of the final design as indicated by past experience would have a distance approximately twice this length.

GLOSSARY

- base plate, mortar.** The structure of a mortar that holds the breech end of the tube and transmits the recoil force to the ground.
- buffer.** A mechanism that absorbs the energy of counterrecoil and brings the recoiling parts to a stop without shock.
- carriage, gun.** Mobile or fired support of a weapon.
- carriage, bottom.** The secondary supporting structure of a gun. It supports the top carriage and transmits firing forces to the ground.
- carriage, top.** Primary supporting structure of a gun. It supports the tipping parts and moves with the cradle in traverse. In double recoil systems, it comprises the bulk of the secondary recoiling mass.
- counterrecoil.** The motion of the recoiling parts as they return to the in-battery position.
- cradle.** The nonrecoiling structure of a weapon that houses the recoiling parts and rotates about the trunnions to elevate the gun.
- elevating mechanism.** Mechanism on a gun carriage by which the tipping parts are elevated or depressed.
- emplacement.** The prepared site of a gun in firing position.
- energy, muzzle.** The combined energy of projectile and propellant gas at the muzzle.
- energy, specific, of weapon.** The ratio of muzzle energy to weight of weapon.
- energy, specific, of recoiling parts.** The ratio of muzzle energy to weight of recoiling parts.
- equilibrator.** The force-producing mechanism that provides a moment about the cradle trunnions equal and opposite to that caused by the muzzle preponderance of the tipping parts.
- firing torque.** The moment induced by the propellant gas force and the inertial force of the recoiling parts caused by their nonlinear lines of action, i.e., the center of gravity of the recoiling parts does not lie on the bore axis.
- gear, elevating.** Upright geared arc attached to the tipping parts or carriage by which the weapon is elevated.
- gear, traversing.** The last gear in the traversing gear train that is attached to the traversing parts.
- moment, weight.** The moment about the trunnion axis caused by the weight of the tipping parts.
- mount, ball.** Small arms or light artillery mount having the tipping parts pivoted by a ball and socket joint.
- mount, bipod.** Small arms or mortar mount consisting of two supporting legs.
- mount, combination.** A tank mount supporting an artillery weapon and a machine gun.
- mount, flexible.** A small arms mount from which a machine gun can be aimed over a large range.
- mount, fixed.** A rigid mount for small arms fixed to aircraft. Aiming is achieved by directing the craft.
- mount, gimbal.** A mount which suspends a small arms gun from gimbals.
- mount, gun.** The general term of a structure that supports a gun.
- mount, monopod.** A small arms mount consisting of one leg.
- mount, mortar.** The component of the supporting structure that positions the mortar.
- mount, tripod.** A small arms mount consisting of three legs.
- muzzle preponderance.** The overhanging weight of the tipping parts.

prime mover. A vehicle capable of providing its own means of locomotion.

propellant gas force. The force produced by the propellant gas acting over the bore area.

recoil. The movement of a gun opposite to the direction of projectile travel.

recoil, double. A system in which the gun recoils on the top carriage and the top carriage recoils on the bottom carriage.

recoil, energy of. The kinetic energy of the recoiling parts.

recoil, free. Recoil of a gun, uninhibited by resistance.

recoiling parts. All parts that move in recoil.

recoil, length of. The distance that the recoiling parts move.

recoil mechanism. The unit that absorbs most of the energy of recoil and stores the rest for returning the recoiling parts to battery.

recoil, primary. The recoiling of the gun tube and its associated parts in a double recoil weapon.

recoil resistance. The resistance to recoil consisting of the force developed by the recoil mechanism and the frictional resistance to the moving recoiling parts.

recoil, secondary. The recoiling activity associated with the top carriage in a double recoil weapon.

recoil, single. The recoil associated with a weapon when only the gun tube and its attached parts move in recoil.

spade. The vertical member of a mount which is buried in the ground to transmit lateral loads into the ground.

tipping parts. The cradle, gun tube and associated parts which rotate about the trunnions.

trail, single. A single rearward thrust member of weapon. It stabilizes the weapon during firing and serves as a link between weapon and prime mover during transport.

trail, split. Two members serving the same purpose as the single trail.

traversing mechanism. The mechanism that transmits power to the traversing parts.

traversing parts. All the units which move in traverse.

trunnion. One of the two pivots supporting a weapon on its mount and forming the horizontal axis about which the weapon elevates.

velocity, muzzle. The velocity of the projectile as it leaves the muzzle.

velocity of free recoil. The rearward velocity that a weapon would attain if no resistance were offered.

REFERENCES

1. Engineering Design Handbook, 341, Carriages and Mounts Series, *Cradles*.*
 2. Engineering Design Handbook, 342, Carriages and Mounts Series, Recoil *Systems*.*
 3. Engineering Design Handbook, 343, Carriages and **Mounts** Series, Top *Carriages*.*
 4. Engineering Design Handbook, 344, Carriages and Mounts Series, *Bottom Carriages*.*
 5. Engineering Design Handbook, 345, Carriages and Mounts Series, *Equilibrators*.*
 6. Engineering Design Handbook, 346, Carriages and Mounts Series, *Elevating Mechanisms*.*
 7. Engineering Design Handbook, 347, Carriages and Mounts Series, *Traversing Mechanisms*.+
 8. T. J. Hayes, *Elements of Ordnance*, John Wiley and Sons, New York, 1938.
- See inside back cover for information on handbook designation.

ENGINEERING DESIGN HANDBOOK. SERIES

The Engineering Design Handbook Series is intended to provide a compilation of principles and fundamental data to supplement experience in assisting engineers in the evolution of new designs which will meet tactical and technical needs while also embodying satisfactory producibility and maintainability.

Listed below are the Handbooks which have been published or submitted for publication. Handbooks with publication dates prior to 1 August 1962 were published as 20-series Ordnance Corps pamphlets. AMC Circular 310-38, 19 July 1963, redesignated those publications as 706-series AMC pamphlets (i.e., ORDP 20-138 was redesignated AMCP 706-138). All new, reprinted, or revised Handbooks are being published as 706-series AMC pamphlets.

<u>General and Miscellaneous Subjects</u>		<u>Ballistic Missile Series</u>	
<u>Number</u>	<u>Title</u>	<u>Number</u>	<u>Title</u>
106	Elements of Armament Engineering, Part One, Sources of Energy	281(S-RD)	Weapon System Effectiveness (U)
107	Elements of Armament Engineering, Part Two, Ballistics	282	Propulsion and Propellants
108	Elements of Armament Engineering, Part Three, Weapon Systems and Components	284(C)	Trajectories (U)
110	Experimental Statistics, Section 1, Basic Concepts and Analysis of Measurement Data	286	Structures
111	Experimental Statistics, Section 2, Analysis of Enumerative and Classificatory Data	<u>Ballistics Series</u>	
112	Experimental Statistics, Section 3, Planning and Analysis of Comparative Experiments	140	Trajectories, Differential Effects, and Data for Projectiles
113	Experimental Statistics, Section 4, Special Topics	160(S)	Elements of Terminal Ballistics, Part One, Introduction, Kill Mechanisms, and Vulnerability (U)
114	Experimental Statistics, Section 5, Tables	161(S)	Elements of Terminal Ballistics, Part Two, Collection and Analysis of Data Concerning Targets (U)
134	Maintenance Engineering Guide for Ordnance Design	162(S-RD)	Elements of Terminal Ballistics, Part Three, Application to Missile and Space Targets (U)
135	Inventions, Patents, and Related Matters	<u>Carriages and Mounts Series</u>	
136	Servomechanisms, Section 1, Theory	340	Carriages and Mounts--General
137	Servomechanisms, Section 2, Measurement and Signal Converters	341	Cradles
138	Servomechanisms, Section 3, Amplification	342	Recoil Systems
139	Servomechanisms, Section 4, Power Elements and System Design	343	Top Carriages
170(C)	Armor and Its Application to Vehicles (U)	344	Bottom Carriages
252	Gun Tubes (Guns Series)	345	Equilibrators
270	Propellant Actuated Devices	346	Elevating Mechanisms
290(C)	Warheads--General (U)	347	Traversing Mechanisms
331	Compensating Elements (Fire Control Series)	<u>Materials Handbooks</u>	
355	The Automotive Assembly (Automotive Series)	301	Aluminum and Aluminum Alloys
<u>Ammunition and Explosives Series</u>		302	Copper and Copper Alloys
175	Solid Propellants, Part One	303	Magnesium and Magnesium Alloys
176(C)	Solid Propellants, Part Two (U)	305	Titanium and Titanium Alloys
177	Properties of Explosives of Military Interest, Section 1	306	Adhesives
178(C)	Properties of Explosives of Military Interest, Section 2 (U)	307	Gasket Materials (Nonmetallic)
210	Fuzes, General and Mechanical	308	Glass
211(C)	Fuzes, Proximity, Electrical, Part One (U)	309	Plastics
212(S)	Fuzes, Proximity, Electrical, Part Two (U)	310	Rubber and Rubber-Like Materials
213(S)	Fuzes, Proximity, Electrical, Part Three (U)	311	Corrosion and Corrosion Protection of Metals
214(S)	Fuzes, Proximity, Electrical, Part Four (U)	<u>Military Pyrotechnics Series</u>	
215(C)	Fuzes, Proximity, Electrical, Part Five (U)	186	Part Two, Safety, Procedures and Glossary
244	Section 1, Artillery Ammunition--General, with Table of Contents, Glossary and Index for Series	187	Part Three, Properties of Materials Used in Pyrotechnic Compositions
245(C)	Section 2, Design for Terminal Effects (U)	<u>Surface-to-Air Missile Series</u>	
246	Section 3, Design for Control of Flight Characteristics	291	Part One, System Integration
247(C)	Section 4, Design for Projection (U)	292	Part Two, Weapon Control
248	Section 5, Inspection Aspects of Artillery Ammunition Design	293	Part Three, Computers
249(C)	Section 6, Manufacture of Metallic Components of Artillery Ammunition (U)	294(S)	Part Four, Missile Armament (U)
		295(S)	Part Five, Countermeasures (U)
		296	Part Six, Structures and Power Sources
		297(S)	Part Seven, Sample Problem (U)