

UNCLASSIFIED

AD NUMBER

AD832615

LIMITATION CHANGES

TO:

Approved for public release; distribution is unlimited.

FROM:

Distribution authorized to U.S. Gov't. agencies and their contractors; Critical Technology; MAY 1968. Other requests shall be referred to Air Force Aero Propulsion Laboratory, Wright-Patterson AFB, OH 45433. This document contains export-controlled technical data.

AUTHORITY

AFAPL ltr dtd 4 May 1973

THIS PAGE IS UNCLASSIFIED

AD832615

AFAPL-TR-68-43

**PYROCHEMICAL THERMIONIC  
HEAT SOURCE INVESTIGATION**

P. Jalichandra and A. E. Campbell  
Electro-Optical Systems, Inc.  
A Xerox Company  
and  
G. A. Marxman and E. L. Capener  
Stanford Research Institute

TECHNICAL REPORT AFAPL-TR-68-43

May 1968



Air Force Aero Propulsion Laboratory  
Air Force Systems Command  
Wright-Patterson Air Force Base, Ohio

This document is subject to special export controls and each transmittal to foreign governments or foreign nationals may be made only with prior approval of the Air Force Aero Propulsion Laboratory

*Attn: AFAP-2 W-P AFB, Ohio 45433*

NOTICE

When Government drawings, specifications, or other data are used for any purpose other than in connection with a definitely related Government procurement operation, the United States Government thereby incurs no responsibility nor any obligation whatsoever; and the fact that the Government may have formulated, furnished, or in any way supplied the said drawings, specifications, or other data, is not to be regarded by implication or otherwise as in any manner licensing the holder or any other person or corporation, or conveying any rights or permission to manufacture, use, or sell any patented invention that may in any way be related thereto.

This document is subject to special export controls and each transmittal to foreign governments or foreign nationals may be made only with prior approval of the Air Force Aero Propulsion Laboratory

ADDRESSION for	
CPSTI	WRITE SECTION <input type="checkbox"/>
DAC	DIFF SECTION <input checked="" type="checkbox"/>
UNANNOUNCED	<input type="checkbox"/>
JUSTIFICATION	
.....	
BY	
.....	
CLASSIFICATION AVAILABILITY CODE	
.....	
DISTR. STATEMENT SECURITY	
.....	
2	

Copies of this report should not be returned unless return is required by security considerations, contractual obligations, or notice on a specific document.

PYROCHEMICAL THERMIONIC  
HEAT SOURCE INVESTIGATION

P. Jalichandra  
A. E. Campbell  
G. A. Marxman  
E. L. Capener

## FOREWORD

This report was prepared by Electro-Optical Systems, Inc., a Xerox Company, Pasadena, California, covering work initiated under Contract F33615-67-C-1545, Task 314520-007. The work was administered under the direction of the Air Force Aero Propulsion Laboratory, with Mr. Albert E. Wallis (APIP-2) as Project Engineer.

The program consisted of three principal tasks, namely, Heat Source Investigation, Materials Compatibility Study, and System Conceptual Design. The heat source effort was carried out by Stanford Research Institute under a subcontract, with G. A. Marxman and E. L. Capener as principal investigators. The materials compatibility work was performed by A. E. Campbell, Jr. The system conceptual design and overall program direction were performed by P. Jalichandra.

This report covers work accomplished during the period 27 March 1967 through 29 January 1968. This report was submitted by the authors in February 1968 and was published by EOS under secondary report number 7214-Final.

Publication of this report does not constitute Air Force approval of the report's findings or conclusions. It is published only for the exchange and stimulation of ideas.

Curtis Kelly  
Chief, Energy Conversion Branch  
Aerospace Power Division  
Air Force Aero Propulsion Laboratory

## ABSTRACT

This report describes a feasibility study of a chemically fueled thermionic generator and includes a study of pyrochemical fuels for this generator. The program consisted of three tasks: heat source study, materials compatibility study, and system conceptual design. System performance goals were that the generator should have a capability of from 1 to 100 kW with a minimum specific energy of 100 W-hr/lb for up to 30 minutes. Fuel preparation and processing are specified and the characteristics of three fuel combinations (Al/KClO<sub>4</sub>, Mg/KClO<sub>4</sub>, and Mg/Teflon) were measured. A solid bed fuel or a slurry fuel system is recommended. Vapor-deposited rhenium was chosen as the combustion chamber material. It was concluded that a pyrochemical thermionic generator using solid fuels (e.g., Al/KClO<sub>4</sub>) is feasible and offers a lightweight power supply with a specific energy of 130 to 150 W-hr/lb for a 30-minute operation with a growth potential in excess of 300 W-hr/lb. This generator concept is believed to be superior to other power supply concepts and a recommended plan for the development of such a generator is outlined in this report.

## CONTENTS

I. INTRODUCTION	1
1. Program Objectives	1
2. Performance Goals	3
3. System Constraints	3
4. Subsystem Requirements	3
5. Summary of Results	4
6. Comparison With Other Power Supply Concepts	6
7. Recommendations	8
II. HEAT SOURCE INVESTIGATION	9
1. Heat Source Objectives	9
2. Literature Review	10
3. Computer Fuel Analysis	19
4. Experimental Fuel Analysis	28
5. Heat Transfer Experiment	41
III. MATERIALS COMPATIBILITY INVESTIGATION	57
1. Selection of Container Material	57
2. Container Fabrication and Processing	58
3. High Temperature Experiments	61
4. Post-Operation Examination	62
5. Summary	65
IV. SYSTEM CONCEPTUAL DESIGN	71
1. Analysis and Evaluation of Experimental Data	71
2. Conceptual Design	82
3. Performance Analysis	89
V. RECOMMENDATIONS	103
1. Phase II Program	104
2. Phase III Program	107
REFERENCES	109

## ILLUSTRATIONS

1	Generator Concept Using Solid Bed Fuel	2
2	Performance Comparison of Various Energy Systems	7
3	Heat of Formation of Oxides	11
4	Adiabatic Combustion Temperature of Elements in Oxygen	12
5	Heat of Formation of Fluorides	14
6	Density versus Pellet Weight	34
7	Partially Decomposed Aluminum/Potassium Perchlorate Fuel Pellet	36
8	Ignition Delay of Magnesium/Teflon Pellets versus Temperature	39
9	Ignition Delay of Magnesium/Potassium Perchlorate Pellets versus Temperature	40
10	Fuel Pellets and Feed Tape	43
11	Ignition Delay Times of Al/KP Fuel as a Function of Mg Additive	44
12	Fuel Igniter Configuration	46
13	Steel Reactor Setup for Ignition and Combustion Experiments	48
14	Instrumentation for Heat Transfer Equipment	49
15	Oscillograph Record of Test 4 - Al/KP Pellet Feed	51
16	Heat Transfer Test 7 Firing Record	52
17	Heat Transfer Test 9 Firing Record	53
18	Heat Transfer Test 10 Firing Record	55
19	Vapor-Deposited Tungsten Container	59
20	Vapor-Deposited Tungsten Container Loaded With Fuel Combustion Products Prior to Final Welding	60
21	200X Photomicrograph of Vapor-Deposited Tungsten Crucible After 18 Minutes Operation at 1500°C	63
22	200X Photomicrograph of Vapor-Deposited Tungsten Crucible After 30 Minutes Operation With Fuel Byproducts at 1700°C. No Evidence of Attack.	64
23	Reaction Zone (0.0015 in.) of Vapor-Deposited Rhenium and Byproducts of Aluminum/Potassium Perchlorate (Mag: 110X)	66
24	Reaction Zone (0.0015 in.) of Vapor-Deposited Rhenium and Byproducts of Aluminum/Potassium Perchlorate (Mag: 220X)	67

**PRECEDING  
PAGE BLANK**

## ILLUSTRATIONS (contd)

25	Reaction Zone (0.0015 in.) of Vapor-Deposited Rhenium and Byproducts of Aluminum/Potassium Perchlorate (Mag: 650X)	68
26	Time History and Chronological Events of Test Run No. 9	72
27	Monochromatic Absorptivity of Luminous and Nonluminous Benzene-Air Flames at 1760°C (after Miller, et al, Ref. 13)	78
28	Generator Concept Using Solid Bed Fuel	83
29	Conceptual Detail of Thermionic Generator	85
30	Design of Heatpipe Converter	86
31	Generator Concept Using Pellet Feed System	88
32	Generator With Slurry Fuel Feed	90
33	Thermionic Converter Power Density versus Emitter Temperature	93
34	Thermionic Converter Efficiency versus Emitter Temperature	94
35	Heat Exchanger	96
36	Specific Energy Characteristics of Al/KClO <sub>4</sub> Fueled Generator	99
37	Specific Volume Characteristics of Al/KClO <sub>4</sub> Fueled Generator	99
38	Specific Energy Characteristics as a Function of Fuel Energy	101

TABLES

I	Heats of Formation of Halides With Elements	15
II	Heats of Reaction of Selected Elements With Oxidizers	17
III	Melting and Boiling Points of Elements	18
IV	Melting and Boiling Points of Oxides	18
V	Melting and Boiling Points of Fluorides	19
VI	Predicted Combustion Products From the Reaction of 32.7% Magnesium and 67.3% Teflon (Stoichiometric Mixture)	21
VII	Predicted Combustion Products From the Reaction of 40% Magnesium and 60% Teflon	22
VIII	Predicted Combustion Products From the Stoichiometric Reaction of Magnesium and Potassium Perchlorate	23
IX	Predicted Combustion Products From the Stoichiometric Reaction of Aluminum and Potassium Perchlorate	24
X	Predicted Combustion Products From the Stoichiometric Reaction of Zirconium and Potassium Perchlorate	25
XI	Predicted Combustion Products From the Stoichiometric Reaction of Iron Oxide and Aluminum	25
XII	Predicted Combustion Products From the Stoichiometric Reaction of Cupric Oxide and Aluminum	26
XIII	Predicted Combustion Products From the Stoichiometric Reaction of Cupric Oxide and Zirconium	26
XIV	Summary of Thermodynamic Parameters for Alternative Fuel Mixes	27
XV	Measured Noncondensable Gases and Heat of Reactions	30
XVI	Noncondensable Gases Evolved From a 60% $KClO_4$ and 40% Aluminum Fuel	31
XVII	Fuel Pellet Burning Times	37
XVIII	Summary of Results Materials Compatibility Study	69
XIX	System Weight for Al/KP Fuel ( $\phi_c = 1.0$ eV)	98
XX	System Weight for Al/KP Fuel ( $\phi_c = 1.2$ eV)	98
XXI	Performance Characteristics of High Energy Fuels	100

## SECTION I

### INTRODUCTION

This document reported results of a feasibility investigation aimed toward the development of a chemically fueled thermionic generator. The generator concept, which is depicted in Fig. 1, consists of a chemical fuel section, a thermionic generator proper, and a power conditioner. In this report the power conditioning aspect was not covered since the details of the user's requirements were not known.

The principle of the generator operation is a simple one. Upon command, an electrical signal is sent to initiate combustion. Heat resulting from the chemical reaction is transported to the thermionic converter via a heat-pipe combustion chamber. Waste heat is rejected to space by a high-temperature radiator which is an integral part of the converter. The resulting system offers a highly compact and lightweight power supply suitable for short duration applications.

#### 1. PROGRAM OBJECTIVES

The effort of this contract consisted of three principal investigation areas, namely

- Heat source investigation. The primary objective was to obtain experimental data such as the ignition, combustion, and heat transfer characteristics of chemical fuels.
- Materials compatibility investigation which had an objective of insuring that the combustion products can be contained within the mission lifetime.
- A system conceptual design to evaluate the generator performance characteristics utilizing the experimental data obtained.

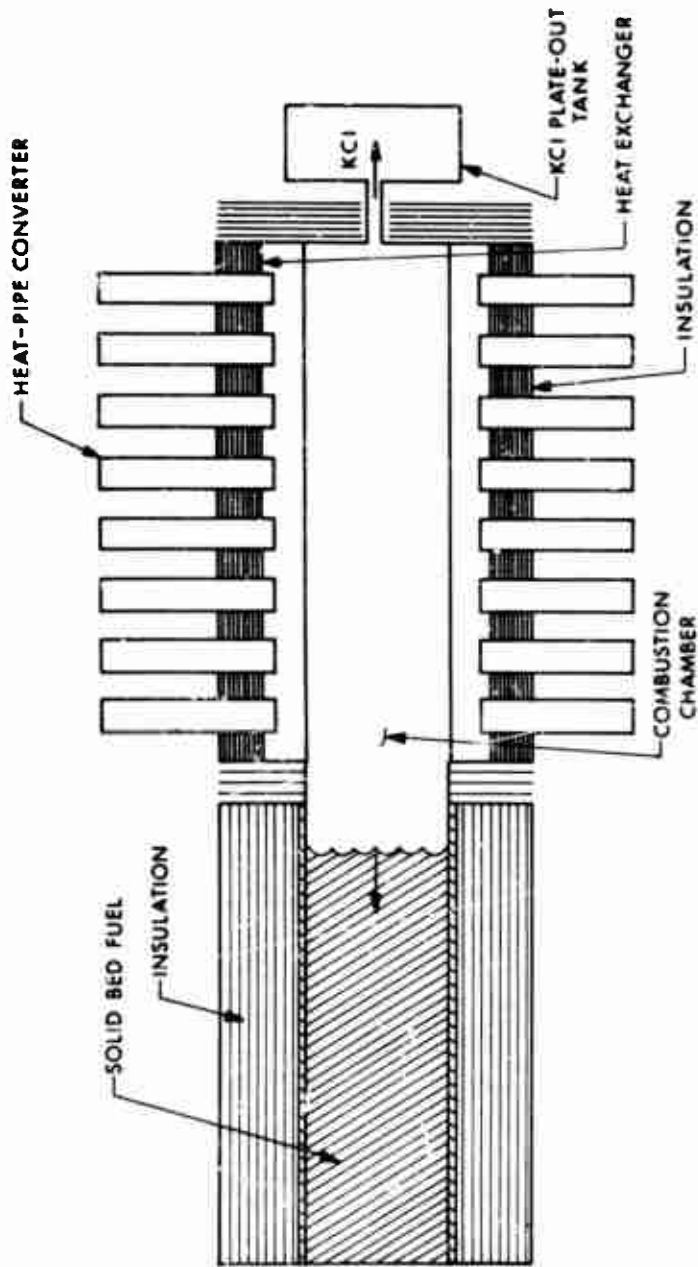

Figure 1. Generator Concept Using Solid Bed Fuel

## 2. PERFORMANCE GOALS

The system performance goals were:

- A generator concept capability ranging from 1 to 100 kW
- A specific energy of 100 watt-hr/lb or greater
- A lifetime up to 30 minutes

## 3. SYSTEM CONSTRAINTS

The constraints which were established prior to the start of the program were:

- No exhaust of combustion products
- Chemical fuels must be easy to store with long shelf life
- Fuel feed system should be simple to enhance system reliability
- Fuels selected for investigation must offer a minimum risk in achieving the proof of feasibility (in terms of ignition and combustion difficulty)

## 4. SUBSYSTEM REQUIREMENTS

A system analysis was performed to establish the subsystem requirements based on the desired performance goals and constraints. These requirements (or objectives) were then used as a framework to guide the exploratory research effort.

a. Heat Source Requirements

- Fuels should have an energy yield of 2000 cal/g or greater.
- It should ignite and burn without difficulty.
- It should attain the combustion chamber wall temperature of 1750°C.
- It should generate a minimum gas so that a closed chemical reactor can be used.
- Combustion products are containable within mission lifetime.

b. Thermionic Converter Requirements

- Heat-pipe converters (both emitter and collector) to achieve a fast start-up, light weight, and uniform temperature distribution
- Power density in the range of 40-50 watts/cm<sup>2</sup>
- Converter efficiency of 30%

The converter requirements represent a moderate advancement in technology. The state-of-the-art converter has a power density of 30 watts/cm<sup>2</sup> at 20% efficiency.

5. SUMMARY OF RESULTS

The analytical and experimental results (reported in Sections II, III, IV) have clearly demonstrated the feasibility and attractiveness of the pyrochemical thermionic generator concept. Program achievements and problem areas are summarized below.

a. Heat Source Investigation

- Establish specifications for fuel preparation and processing to insure a minimum gas generation and to insure no explosive hazards.

- Ignition and combustion characteristics, and the energy output measured were:

	<u>Al/KClO<sub>4</sub></u>	<u>Mg/KClO<sub>4</sub></u>	<u>Mg/Teflon</u>
Ignition temperature (°C)	1100	620	610
Burning rate (cm/sec)	0.030	0.084	0.041
Energy output (cal/g)	2100	2300	1900

(Fuel compositions are 40% metal powder and 60% oxidizer)

- Data obtained from the heat transfer experiment (transient) indicated that radiation was the mode of heat transfer. The measured heat flux and flame temperature were compatible with thermionic conversion requirements. Combustion efficiencies between 90 to 100% were achieved. These are summarized as follows:

	<u>Al/KClO<sub>4</sub></u>	<u>Mg/Teflon</u>	<u>Desired</u>
Heat flux (watts/cm <sup>2</sup> )	85	115	50
Flame temperature (°C)	2050 (peak) 1830 (ave)	2470 (peak) 2000	2060 (steady-state)
Combustion efficiency (%)	90-100	90-100	100

- The problems encountered were: The difficulty in the pressure measurement associated with the fast reaction, and the flame flashback which caused difficulty in achieving runs of long duration with the laboratory fuel pellet feed system.
- A solution to the flashback problem appears to be the use of a solid bed fuel which requires no feed mechanism. An alternate solution will be to use slurry fuels with a passively cooled injector nozzle.

#### b. Materials Compatibility Investigation

- Vapor-deposited tungsten and rhenium were found to be compatible with reaction products of Al/KClO<sub>4</sub> fuel at temperatures of 1700° to 1800°C for 30 minutes.

- Vapor-deposited rhenium is recommended as the combustion chamber material because its superior properties of ductibility and resistance to thermal cycling and shocks.

#### c. Concept Performance Characteristics

- A pyrochemical thermionic generator using solid fuels such as Al/KClO<sub>4</sub> offers a lightweight power supply which has a specific energy of 130 to 150 watt-hr/lb for a 30-minute operation.
- The concept has an excellent growth potential. A specific energy exceeding 300 watt-hr/lb appears feasible.

### 6. COMPARISON WITH OTHER POWER SUPPLY CONCEPTS

The watt-hr/lb performance characteristics of various power supply concepts are shown in Fig. 2. For the pyrochemical thermionic generator the specific energy covers a wide range of possibilities. The lower range represents the performance which can be achieved by Al/KClO<sub>4</sub>, Mg/KClO<sub>4</sub>, and Mg/Teflon fuels, which were investigated in detail in this contract. In addition to being a lightweight power source, these fuels offer the possibility of a completely contained generator with attractive long storage life. Higher performance can be obtained by utilizing Mg/N<sub>2</sub>O<sub>4</sub>, Mg/O<sub>2</sub>, Be/N<sub>2</sub>O<sub>4</sub> and Be/O<sub>2</sub> in that order. The N<sub>2</sub>O<sub>4</sub> systems are storable but result in gaseous products which must be exhausted. The O<sub>2</sub> systems offer a possibility of a closed reactor but have a drawback in the use of cryogenic oxygen.

The performance characteristics of the advanced chemical APU and Li-Cl<sub>2</sub> thermal battery are obtained from References 14 and 15. For the Li-Cl<sub>2</sub> battery, the characteristics correspond to the zero-g design. Additional fuel weight has been added which will be required for startup purpose since the thermal battery must be brought up to its operating temperature of 180°C. Based on the performance characteristics shown in Fig. 2, the following conclusions can be drawn:

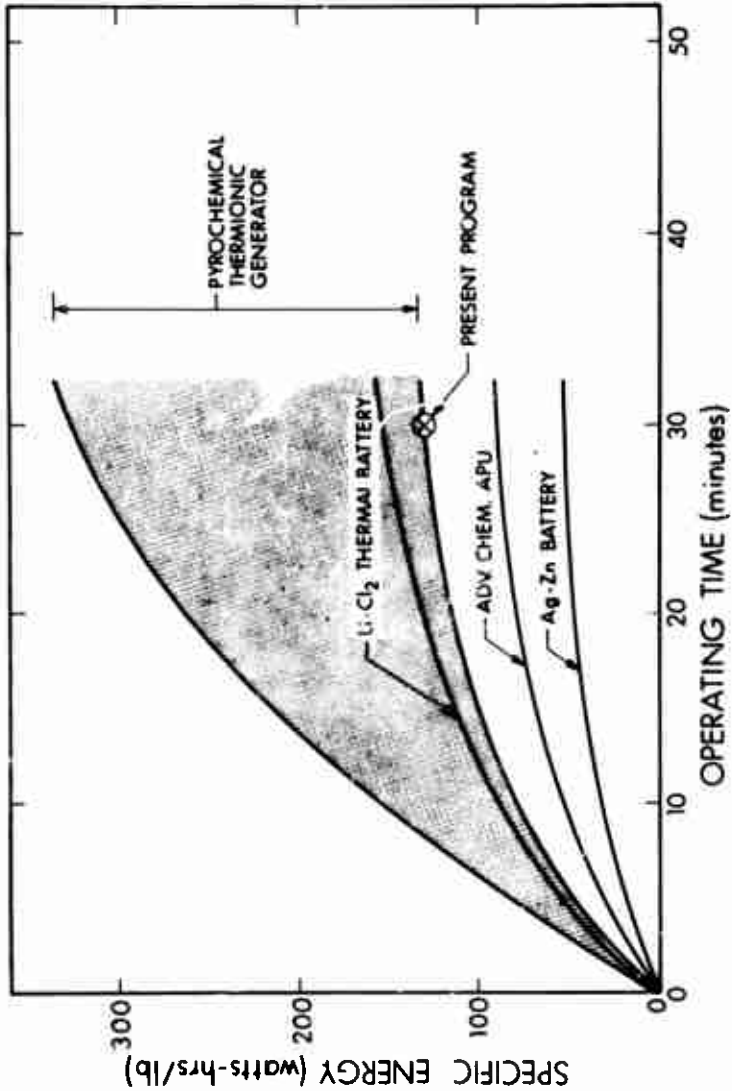

Figure 2. Performance Comparison of Various Energy Systems

- The pyrochemical thermionic generator is superior to the Ag-Zn primary battery.
- It is also superior to the advanced chemical APU.
- The generator concept using Al/KP fuel is competitive with the Li-Cl<sub>2</sub> thermal battery in watt-hr/lb performance. However, it offers a faster startup time.
- The generator concept using advanced fuels will exceed the Li-Cl<sub>2</sub> battery in performance by about a factor of two.

## 7. RECOMMENDATIONS

Because of its high potential performance it is strongly recommended that the pyrochemical thermionic generator be further developed. The recommended development plan is outlined in Section 5 of this report.

## SECTION II

### HEAT SOURCE INVESTIGATION

The purpose of this work was to investigate the feasibility of using a solid or liquid pyrotechnic fuel as a basic heat source for a thermionic power supply. The scope of work was divided into five subtasks as follows:

- Heat source objectives
- Literature review
- Computer fuel analysis
- Experimental fuel analysis
- Heat transfer experiment

Results of the investigation conducted by Standard Research Institute are reported as follows:

#### 1. HEAT SOURCE OBJECTIVES

The program objectives were established based on results of a preliminary system analysis. Initially, either liquids or solids were to be considered as candidate fuels. The following constraints on the fuel system were established. The calorific output of the desired pyrochemical fuel should be greater than 2000 calories/gram. Its equilibrium flame temperature should be sufficiently high that heat could be removed at the combustion chamber wall at about 1700°C. It should generate no gases, or if gases are evolved the pressure generated should be a minimum to prevent a rupture of the closed chemical reactor. Fuels with yield in the range of 1000 to 2000 calories/gram would also be examined beforehand since some of these fuels have desirable characteristics, such as low gas generation, low flame temperature, and slow burning rate. It may be necessary to mix a less energetic fuel with one with a higher yield to obtain a proper combination of combustion temperature, burning rate, and pressure.

The end objective was to make an experimental measurement of the rate of heat transfer from a prototype reactor in a manner to be specified as the work progressed.

## 2. LITERATURE REVIEW

### a. Elemental Fuels

The highest heat evolved during combustion with oxygen is given by the following elements: lithium, beryllium, magnesium, calcium, aluminum, titanium, zirconium, niobium, vanadium, scandium, yttrium, hydrogen, boron, carbon, silicon, and phosphorus. This fact can be substantiated by plotting the dependence of the heat of formation of the oxide versus the atomic number of the elements.<sup>(1)</sup> Data for this plot (Fig. 3) comes from Refs. 2, 3, and 4. Of these high energy compounds, the metals Li, Be, Mg, Ca, Al, Ti, and Zr are available in sufficient quantity and purity to be considered as fuels for this program. Niobium (atomic number 41), vanadium (23), scandium (21), and yttrium (39) also yield high energies; however, none are produced in sufficient quantities to be considered as economical sources of raw materials for pyrochemical fuels. The oxides of hydrogen and carbon were eliminated from consideration because they are gases at the desired operating temperature. Although  $B_2O_3$  is a solid with a melting point<sup>(2)</sup> at  $723^{\circ}K$  and a boiling point at  $2316^{\circ}K$ , other boron compounds are also formed in equilibrium with  $B_2O_3$ . Boron monoxide (BO) is one of these products and it is gaseous at room temperature. Phosphorus is a difficult metal to handle because it ignites spontaneously upon contact with air. It also forms gaseous oxides which would cause the reactor pressure to increase. Silicon has the disadvantage of being difficult to oxidize completely.

Shidlovsky<sup>(1)</sup> also presents adiabatic combustion temperatures of the elements in oxygen plotted versus the atomic number (Fig. 4). Note that Be and Zr give temperatures in excess of  $4000^{\circ}K$  which may limit

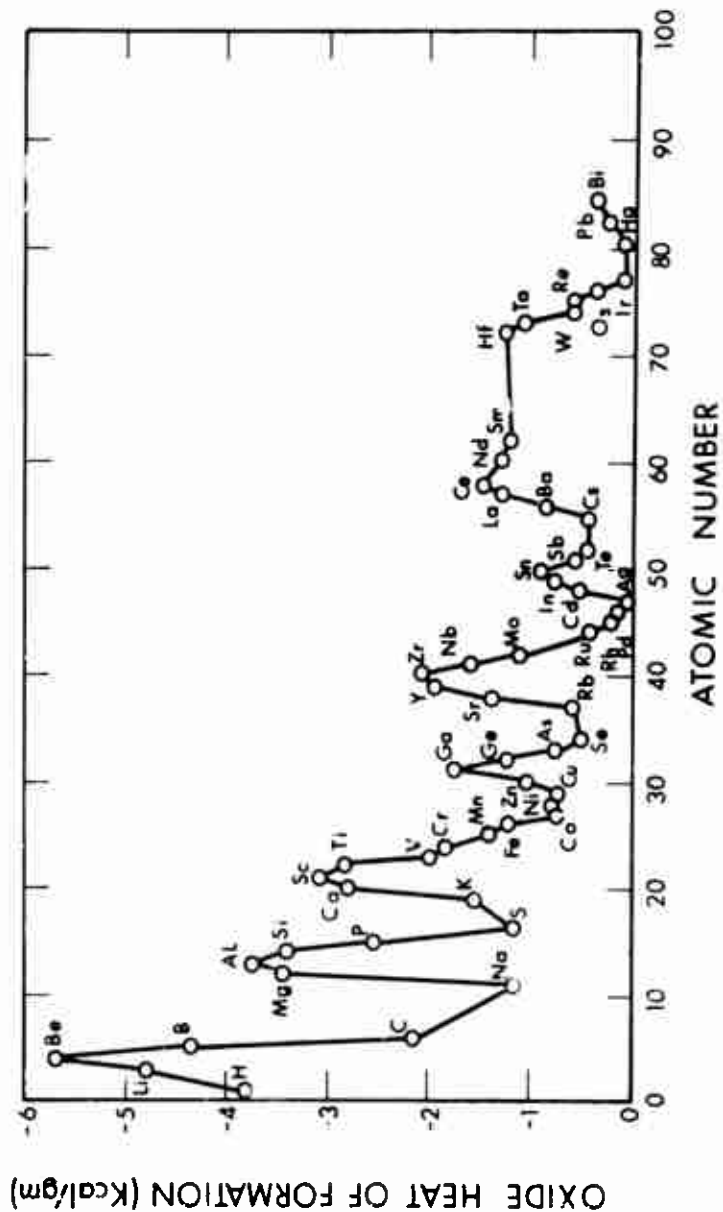

Figure 3. Heat of Formation of Oxides

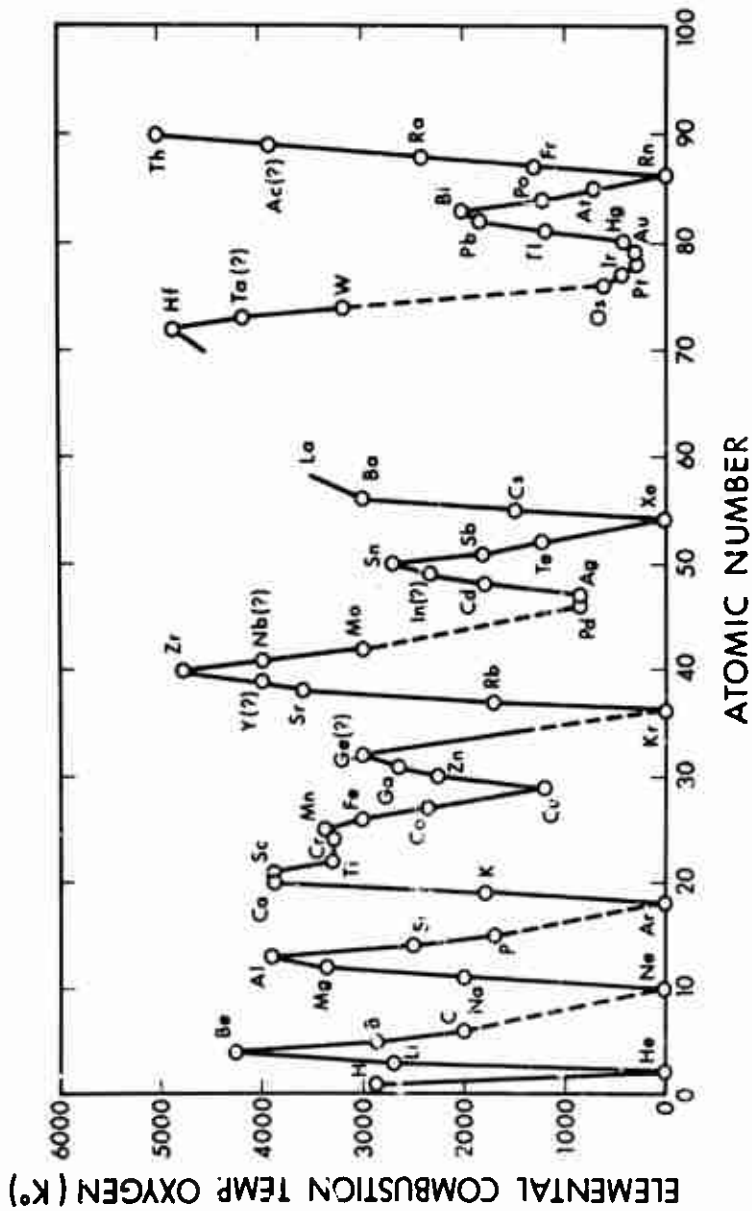

Figure 4. Adiabatic Combustion Temperature of Elements in Oxygen

their potential usefulness in a device of this type. Our remaining candidate metal fuels with oxide heats of formation in excess of 2 kcal/gram all have combustion temperatures in oxygen in excess of 2700°K. Note that Si is somewhat lower at 2500°K and P does not exceed 1700°K. This definitely precludes the use of P as a fuel candidate for an oxidation reaction and places Si in the marginal ranking.

Reaction of fluorine with elements to form fluorides appears to evolve slightly more heat per gram than comparable oxides (Fig. 5 versus Fig. 3). The highest heat evolved during combustion with fluorine again occurs with the same elements that give the highest heat output for combustion with oxygen. However, with these same high heat producing fuels, most of the fluorides are gaseous and this limits their utility for use in the proposed system. Only Li, Na, Mg, K, Ca, Cr, and Mn give solid fluorides of potential use.

In general, the heat evolved by reaction of elements with the halides is in the order of fluorine, chlorine, bromine, and iodine, with fluorine being the highest. Table I lists the heats of formation of the more energetic elements with halides.

Since the degradation in heat output is so severe with all of the halides other than fluorine, only the fluoride reaction is considered energetic enough for the purposes of this study.

#### b. Other Exothermic Reactions

There are two other exothermic reactions which were considered as heat sources. The most important of these is represented by the following equation:



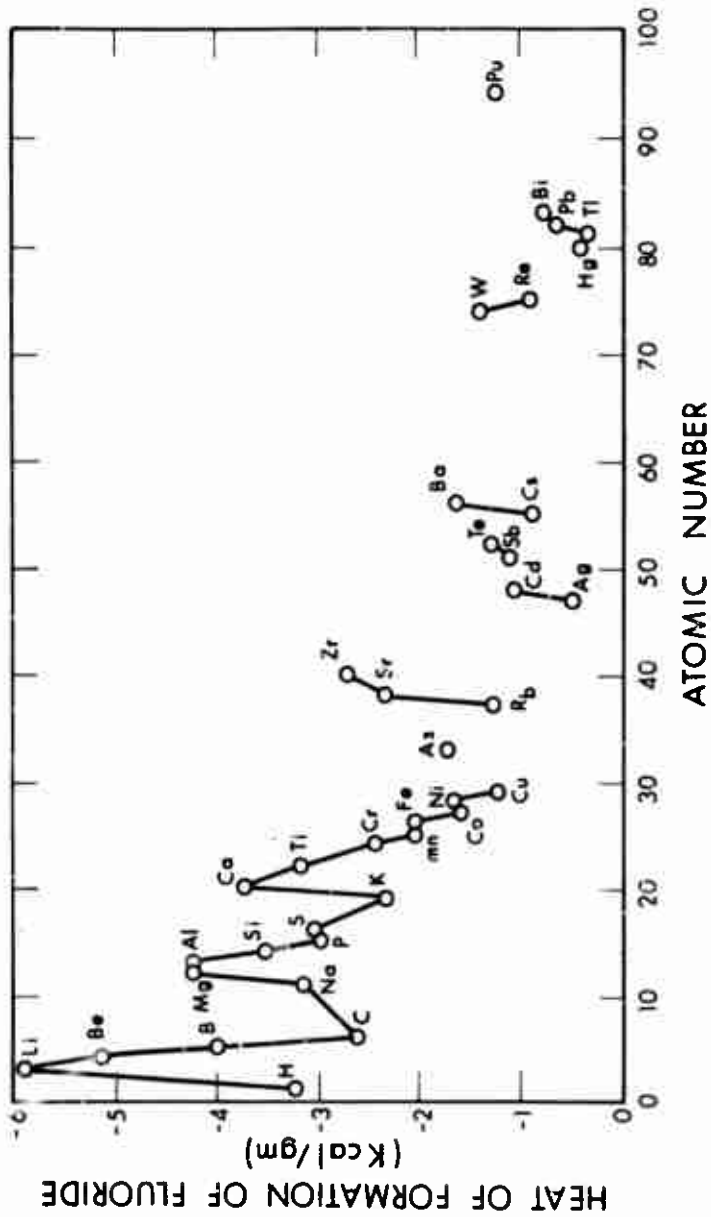

Figure 5. Heat of Formation of Fluorides

TABLE I  
HEATS OF FORMATION OF HALIDES WITH ELEMENTS\*

	<u>- Δ H<sub>f</sub>, 298°K (kcal/mole)</u>			
	<u>Fluorine</u>	<u>Chlorine</u>	<u>Bromine</u>	<u>Iodine</u>
Lithium	145.3	97.5	82.8	65.0
Beryllium	-	112.0	78.3	39.4
Sodium	133.0	98.2	85.5	69.3
Magnesium	266.0	153.2	123.5	86.5
Aluminum	355.7	138.6	120.5	71
Silicon	370.8	154.0	95.0(1)	34.8
Calcium	290.2	190.4	160.7	128.5
Titanium	370	-	155	102
Zirconium	445	230	192	130
Manganese	190	112	90	59

\* Data taken from Ref. 4 except that titanium and zirconium data were taken from Ref. 5.

These binary mixtures of metals and metal oxides are given the general name of thermites. The theoretical thermal output of stoichiometric mixtures of aluminum and  $Fe_2O_3$  or  $Fe_3O_4$  is 0.95 and 0.87 kcal/g, respectively. The peak temperature reported by Ullmann and Mellor<sup>(6,7)</sup> for this reaction is 3273°K and by Fisher<sup>(8)</sup> 2661°K. Other mixtures of metals and metal oxides exceed this calorific output by only about 25%; hence, the thermite-type fuel is considered marginal for application in the program. It is interesting, however, because potentially there is the least likelihood of gas evolution with these reactants. Other combinations<sup>(8)</sup> which have been used as "gaseous" ignition mixtures or first fires for igniting other pyrotechnic devices include the following:

1. 41% zirconium, 10% infusorial earth, and 49% red iron oxide ( $\text{Fe}_2\text{O}_3$ )
2. 25% titanium, 25% silicon, 25% iron oxide, and 25% red lead ( $\text{Pb}_2\text{O}_4$ ).
3. 25% titanium, 25% silicon, and 50% read lead.
4. 15% silicon and 85% red lead.
5. 32-1/2% titanium, 17-1/2% zirconium, and 50% iron oxide.
6. 20% zirconium and 80% lead dioxide ( $\text{PbO}_2$ ).
7. 17-24% magnesium and 81-74% barium peroxide ( $\text{BrO}_2$ ).
8. 33-1/3% silicon, 33-1/3% lead dioxide, and 33-1/3% cuprous oxide ( $\text{Cu}_2\text{O}$ ).

Another unorthodox thermal reaction takes place in the alloying of aluminum and palladium<sup>(9)</sup>. Pyrofuse is a commercial material utilizing the reaction. It takes place at the melting point of aluminum ( $660^\circ\text{C}$ ) with a thermal output of 327 cal/g and produces temperatures above  $2400^\circ\text{K}$ . A disadvantage, besides the unattractively low thermal output, is the high price of the alloy, \$1.60/gram, no doubt due to the scarcity of palladium.

### c. Oxidizers

Only oxidizers capable of solid phase combustion typified in pyrotechnics have been considered in this study. The primary reason for this is the possibility that a liquid fuel of any kind would cause gas generation and pressure within a closed reactor system. The properties of the perchlorate and chlorate oxidizers most frequently used in pyrotechnic fuels are described in Refs. 10 and 11.

The calorific outputs of sodium nitrate and potassium perchlorate in combination with the better elemental fuels are listed in Table II<sup>(9)</sup>. Note that in general these outputs follow the predictions of Fig. 3 for the combination of elements with oxygen.

TABLE II  
HEATS OF REACTION OF SELECTED ELEMENTS WITH OXIDIZERS

<u>Fuel</u>	<u><math>\Delta H_r</math>, kcal/gram</u>	
	<u>NaNO<sub>3</sub></u>	<u>KClO<sub>4</sub></u>
Al	2.2	2.5
Mg	2.1	2.4
B	1.9	2.4
Si	1.7	2.1
Ti	1.5	1.9
Zr	1.4	1.6

The higher outputs of these reactions, 1.5 to 2.5 kcal/g, are appreciably greater than those derived from the simple thermite type reactions where the highest output comes to 1.2 kcal/g for a magnesium-manganese dioxide mixture.

Other oxidizers that are most frequently used in pyrotechnic compositions are NaNO<sub>3</sub>, KNO<sub>3</sub>, Sr(NO<sub>3</sub>)<sub>2</sub>, NaClO<sub>4</sub>, KClO<sub>3</sub>, and BaCrO<sub>4</sub>. Most of the nitrates are gas producing. Barium chromate is less energetic than the most common perchlorates. Fluorine is supplied as an oxidizer in the form of polytetrafluoroethylene (Teflon), a completely fluorinated polymer with a carbon skeleton. The reaction is

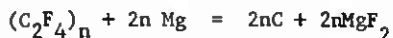

The theoretical heat of combustion amounts to 2.3 kcal/gram.<sup>(1)</sup>

#### d. Phase Changes

Phase changes of reactants and products in all of the proposed pyrotechnic solid fuels will profoundly affect the operation of the reactor. Solid oxides or fluorides deposited on the reactor walls will tend to

slow the heat transfer rate. Vaporization of excess metal fuels existing because of nonequilibrium combustion or use of fuel-rich mixtures will tend to cause pressure increases which are undesirable. Tables III, IV, and V list the melting and boiling points of elements, oxides, and fluorides. These data reveal a number of potential problem areas.

TABLE III  
MELTING AND BOILING POINTS OF ELEMENTS <sup>(12)</sup>

<u>Element</u>	<u>M.P., °C</u>	<u>B.P., °C</u>
Al	660	2500
B	2050	--
Be	1284	(2400)
Ca	850	1420
Li	181	1370
Mg	650	1105
Si	1430	2600
Ti	1660	3260
Zr	1868	(4750)

TABLE IV  
MELTING AND BOILING POINTS OF OXIDES <sup>(12)</sup>

<u>Oxide</u>	<u>M.P., °C</u>	<u>B.P., °C</u>
Al <sub>2</sub> O <sub>3</sub>	2030	(d) 3257
B <sub>2</sub> O <sub>3</sub>	450	2247
BeO	2530	4120
CaO	2600	3527
Li <sub>2</sub> O	1430	4197
MgO		(s) 2770
SiO <sub>2</sub>	1713	(d) 1977
TiO <sub>2</sub>	1920	--
ZrO <sub>2</sub>	2700	(4300)

(d) = decomposes

(s) = sublimes

TABLE V

MELTING AND BOILING POINTS OF FLUORIDES<sup>(5)</sup>

<u>Fluoride</u>	<u>M.P., °C</u>	<u>B.P., °C</u>
AlF <sub>3</sub>	(s) 760	
BF <sub>3</sub>	-127	-100
BeF <sub>2</sub>	(s) 800	
CuF <sub>2</sub>	1360	2500
LiF	842	1676
MgF <sub>2</sub>	1266	2239
SiF <sub>4</sub>	-90	-86
TiF <sub>4</sub>	(s) 284	
ZrF <sub>4</sub>	(s) 600	

(s) = sublimes

All of the higher energy fluoride reactions result in products which are gaseous at the desired reactor operating temperature except for CaF<sub>2</sub> or MgF<sub>2</sub>. The oxides are all either liquid or gaseous at 1700°C. Some of the elemental fuels also have undesirably low boiling points for the proposed system operating temperatures. Calcium boils at 1420°C, lithium at 1370°C, and magnesium at 1105°C. Therefore, any of these used in excess to ensure complete combustion with the oxidizer would have a finite vapor pressure at the reactor operating temperature.

## 3. COMPUTER FUEL ANALYSIS

Theoretical thermochemical computations were made on solid heat-source pyrochemical systems of primary interest to gain information on the products of combustion. We were primarily interested in determining the gaseous products and the equilibrium flame temperatures. Combustion pressure was taken as a variable, because potentially we were concerned with a start-up under space environmental conditions. We also varied the composition of the fuel/oxidizer system to allow us to estimate whether this was going to be a first order variable.

Table VI lists the combustion products for burning a stoichiometric mixture of Mg/Teflon at absolute pressures of 1 millimeter Hg, 1 atmosphere, and 13.6 atmospheres. These data indicate that the gas evolution from the magnesium/Teflon system will result in high pressures in a closed, constant-volume reactor. One of the primary reasons for the large quantity of gaseous products is the high flame temperature of the combustion process. Even at a low absolute pressure of 1 mm Hg, the resulting temperature of 2641<sup>o</sup>K is well above the boiling point of magnesium fluoride. It should also be noted that an increase in pressure causes a substantial increase in flame temperature, for at 13.6 atmospheres the corresponding temperature is 3667<sup>o</sup>K. It appears feasible to reduce the pressure from MgF<sub>2</sub> by lowering the flame temperature below the MgF<sub>2</sub> boiling point, 2512<sup>o</sup>K; however, the equilibrium reaction appears to leave an appreciable residue of unreacted Mg, which will also contribute to the predicted reactor pressure as long as operation is above its boiling point of 1380<sup>o</sup>K.

As can be seen from the data in Tables VI and VII, for a mixture containing excess magnesium (40 percent magnesium and 60 percent Teflon) the flame temperature decreases only slightly from that given by the stoichiometric mixture. Furthermore, the total number of moles of gases has increased, primarily due to the excess magnesium. The net result will be a slight increase in pressure in a closed reactor. Tentatively, it was concluded that this fuel system would not be as attractive as the others from the standpoint of gas generation. However, it will be retained for further study since the feed system may be the least difficult.

A number of alternative fuel mixes have been examined thermodynamically. The predicted combustion products are listed in Tables VIII through XIII. A summary of the data is in Table XIV. The flame temperature and theoretical moles of gas are for stoichiometric mixtures. All can be expected to produce less gas than the magnesium/Teflon fuel mixture.

TABLE VI

PREDICTED COMBUSTION PRODUCTS FROM THE REACTION OF 32.7%  
MAGNESIUM AND 67.3% TEFLON (STOICHIOMETRIC MIXTURE)

<u>Products</u>	<u>Moles/100 gram mixture</u>		
	<u>p = 1 mm Hg</u>	<u>p = 1 atm</u>	<u>p = 13.6 atm</u>
C	0.0014	0.0017	0.0010
F	0.2710	0.0710	0.0302
Mg	0.2035	0.1263	0.0852
CF	0.0010	0.0021	0.0017
CF <sub>2</sub>		0.0013	0.0013
CO	0.0012	0.0013	0.0012
C <sub>2</sub>		0.0015	0.0012
C <sub>2</sub> F <sub>2</sub>	0.0693	0.0927	0.0734
C <sub>3</sub>	0.0028	0.0058	0.0040
MgF		0.0046	0.0069
MgF <sub>2</sub>	1.1395	1.2129	1.2516
C <sub>(s)</sub>	2.8833	2.6547	2.6370
Total Moles Gas	1.6898	1.5212	1.4578
T <sub>(c)</sub> , °K	2641	3359	3667

Subscript (s) = solid

(c) = adiabatic flame temperature

TABLE VII

PREDICTED COMBUSTION PRODUCTS FROM THE REACTION OF  
40% MAGNESIUM AND 60% TEFLON

<u>Products</u>	<u>Moles/100 grams mixture</u>	
	<u>p = 1 atm</u>	<u>p = 13.6 atm</u>
C	0.0008	0.0002
F	0.0212	0.0038
Mg	0.4309	0.4112
CF	0.0005	0.0001
CF <sub>2</sub>	0.0002	0.00004
CO	0.0015	0.0015
C <sub>2</sub>	0.0006	0.0002
C <sub>2</sub> F <sub>2</sub>	0.0124	0.0029
C <sub>3</sub>	0.0024	0.0006
MgF	0.0065	0.0089
MgF <sub>2</sub>	1.1840	1.2013
C(s)	1.1745	1.2008
Total Moles Gas	1.6609	1.6306
T(c), °K	3244	3396

TABLE VIII

PREDICTED COMBUSTION PRODUCTS FROM THE STOICHIOMETRIC  
REACTION OF MAGNESIUM AND POTASSIUM PERCHLORATE

<u>Products</u>	<u>Moles/100 grams mixture</u>	
	<u>p = 1 mm Hg</u>	<u>p = 1 atm</u>
O	0.1937	0.612
Cl	0.1379	0.0859
Mg	0.7773	0.4942
K	0.1437	0.1050
KCl	0.2796	0.3125
O <sub>2</sub>	0.2932	0.1715
MgO	0.0596	0.1422
MgO (s)	0.8554	
MgO (L)		1.0430
Total Moles Gas	1.8896	1.4960
T <sub>(c)</sub> , °K	2417	3337

TABLE IX

PREDICTED COMBUSTION PRODUCTS FROM THE STOICHIOMETRIC  
REACTION OF ALUMINUM AND POTASSIUM PERCHLORATE

<u>Products</u>	<u>Moles/100 grams mixture</u>	
	<u>p = 1 mm Hg</u>	<u>p = 1 atm</u>
O	0.3168	0.2251
Cl	0.2213	0.1119
Al	0.3558	0.2364
K	0.3751	0.2802
AlCl	0.1506	0.1557
AlO	0.0633	0.1018
Al <sub>2</sub> O	0.0361	0.0731
KCl	0.0562	0.1455
O <sub>2</sub>	0.0212	0.0313
Al <sub>2</sub> O <sub>3</sub> (L)	0.4223	0.4180
Total Moles Gas	1.5992	1.3785
T <sub>(c)</sub> , °K	2838	3846

TABLE X

PREDICTED COMBUSTION PRODUCTS FROM THE STOICHIOMETRIC  
REACTION OF ZIRCONIUM AND POTASSIUM PERCHLORATE

<u>Products</u>	<u>Moles/100 grams mixture</u>	
	<u>p = 1 mm Hg</u>	<u>p = 1 atm</u>
O	0.2263	0.2017
Cl	0.2215	0.1423
K	0.2903	0.2151
ZrCl	0.0671	0.0665
KCl	0.0213	0.0932
ZrO	0.0972	0.0893
O <sub>2</sub>	0.0043	0.0143
ZrO <sub>2</sub>	0.0894	0.0560
ZrO <sub>2</sub> (L)	0.3681	0.4060
Total Moles Gas	1.0184	0.8869
T <sub>(c)</sub> , °K	3029	4101

TABLE XI

PREDICTED COMBUSTION PRODUCTS FROM THE STOICHIOMETRIC  
REACTION OF IRON OXIDE AND ALUMINUM

<u>Products</u>	<u>Moles/100 grams mixture</u>
	<u>p = 1 atm</u>
Fe	0.1600
Al <sub>2</sub> O <sub>3</sub> (L)	0.4680
Fe (L)	0.7762
Total Moles Gas	0.1604
T <sub>(c)</sub> , °K	2988

TABLE XII  
 PREDICTED COMBUSTION PRODUCTS FROM THE STOICHIOMETRIC  
 REACTION OF CUPRIC OXIDE AND ALUMINUM

<u>Products</u>	<u>Moles/100 grams mixture</u>
	<u>p = 1 atm</u>
Al	0.0542
Al <sub>2</sub> O	0.0235
CuO	0.1240
Al <sub>2</sub> O <sub>3</sub> (L)	0.2886
Cu (L)	0.9006
 Total Moles Gas	 0.2127
T <sub>(c)</sub> , °K	3606

TABLE XIII  
 PREDICTED COMBUSTION PRODUCTS FROM THE STOICHIOMETRIC  
 REACTION OF CUPRIC OXIDE AND ZIRCONIUM

<u>Products</u>	<u>Moles/100 grams mixture</u>
	<u>p = 1 atm</u>
O	0.0024
CuO	0.0447
ZrO	0.0481
ZrO <sub>2</sub>	0.0045
Cu (L)	0.7536
ZrO <sub>2</sub> (L)	0.3471
 Total Moles Gas	 0.1002
T <sub>(c)</sub> , °K	4025

TABLE XIV  
SUMMARY OF THERMODYNAMIC PARAMETERS  
FOR ALTERNATIVE FUEL MIXES

	Theoretical Δ Hr	Moles-Gas/100 gr.ms		Tc, °K			
		cal/g		1 mm Hg	1 atm	1 mm Hg	1 atm
		1 mm Hg	1 atm	1 mm Hg	1 atm		
1. $\text{KClO}_4 + 4 \text{Mg} \rightarrow \text{KCl} + 4\text{MgO}$	2400	1.890	1.496	2417	3337		
2. $3 \text{KClO}_4 + 3\text{Al} \rightarrow 3\text{KCl} + 4\text{Al}_2\text{O}_3$	2450	1.599	1.379	2838	3846		
3. $\text{KClO}_4 + 2\text{Zr} \rightarrow \text{KCl} + \text{ZrO}_2$	1600	1.018	0.887	3029	4102		
4. $\text{Fe}_2\text{O}_3 + 2\text{Al} \rightarrow 2\text{Fe} + \text{Al}_2\text{O}_3$	960	---a	0.160	---	2988		
5. $3\text{CuO} + 2\text{Al} \rightarrow 3\text{Cu} + \text{Al}_2\text{O}_3$	1000	---	0.213	---	3606		
6. $2\text{CuO} + \text{Zr} \rightarrow 2\text{Cu} + \text{ZrO}_2$	740	---	0.100	---	4025		
7. $\text{C}_2\text{F}_4 + 2\text{Mg} \rightarrow 2\text{MgF}_2 + 2\text{C}$	2320	1.690	1.521	2641	3359		

<sup>a</sup> Did not compute

Each mixture presents a unique problem area. The Mg/KClO<sub>4</sub> fuel does not react completely and leaves magnesium in the combustion products. This will give the same gas problem as the Mg/Teflon mixture. All of the thermite mixtures, reactions 4, 5, and 6, have a low predicted heat of reaction. However, they have attractively lower gas evolutions, in the range of 0.1 to 0.2 moles/100 grams reactants. The lower heat output, of course, would require a greater weight of fuel and higher feed rates. The remaining two reactions involve KClO<sub>4</sub> with either aluminum or zirconium. Both have rather high flame temperatures which can be depressed by adding excess metal; this would also reduce the heat output proportionally. If the flame temperature is lowered below the boiling point of the metal, most of the gas pressure will arise from the dissociation of KCl to K<sup>+</sup> and Cl<sup>-</sup>. These systems appear to offer the highest heat output with the least gas.

Based on these data, it appears that the aluminum/potassium perchlorate, magnesium/potassium perchlorate, and magnesium/Teflon systems are the best compromises. They offer the highest energy output, not excessively high temperatures, and moderate gas evolution.

It should be emphasized that these theoretical data are for adiabatic equilibrium conditions and for constant pressure. In the actual application, the reactor volume will be constant, and the combustion temperature will be determined by the reactor wall temperature and, more importantly, the mode of heat transfer. Since the last factor was not known (it was to be determined from the heat transfer experiment to be performed later) it was not possible to calculate the actual pressure and combustion products species at this time. However, these theoretical results could be advantageously used as a guide for experimental investigation. This proved to be the case.

#### 4. EXPERIMENTAL FUEL ANALYSIS

Early in the program aluminum/potassium perchlorate and magnesium/potassium perchlorate were chosen as the candidate fuels theoretically capable of delivering high energy on a weight basis. We also included magnesium/Teflon high on our candidate list, although its energy capabilities are slightly lower, because of the interesting possibility of making a fluid slurry system from this combination. This tentative selection was based on the following criteria: high heat output, least gas generation, and minimum risk in proof of feasibility objective in terms of ignition and combination difficulties. Higher energy fuels employing Be, Li, or B were not considered because of either the second or third criterion.

### a. Gas Evolution and Energy Output

Thermochemical computer calculations were very helpful during the initial evaluation of various fuel candidates for the heat source. The results of these calculations are reported in the preceding section. Although the computations predict the moles of gas and flame temperatures to be expected from the proposed fuel formulations, these theoretical results are for adiabatic equilibrium conditions and for constant pressure. The fact that heat will be removed at the reactor wall at  $2000^{\circ}\text{K}$ , which is below the adiabatic flame temperature, introduces a nonadiabatic, equilibrium condition which would be extremely difficult to compute because the path between the two states is unknown. Therefore, an effort was made to reduce gas evolution to a minimum by performing experiments in the constant volume combustion chamber using the most promising fuel candidates revealed by the computer analysis. Then these fuels would be burned experimentally to determine the extent to which equilibrium combustion of the fuel was approached in the chemical reactor.

The energy output and moles of gas generated were obtained in a closed bomb calorimeter. The fuel sample, weighing from 10 to 30 grams, was pressed into a stainless steel cup with an internal diameter of 1.370 inches and a depth of 1.247 inches. The cup walls were approximately 1/8 inch thick and the bottom was 1/2 inch thick. The sample was ignited and burned at subatmospheric pressures in a 2-liter stainless steel bomb made from a Hoke cylinder. Pressure measurements made before and after burning were used to compute gas output. After combustion the bomb was allowed to return to ambient temperature before the pressure was recorded, so that only noncondensable gases were measured. The same device was employed as a water bath calorimeter, allowing both gas evolution and heat output to be measured simultaneously. The data in Table XV shows that the lowest gas evolution was measured for the  $\text{Al/KClO}_4$  fuel and the highest gas output was for the  $\text{Mg/KClO}_4$  system.

TABLE XV

## MEASURED NONCONDENSIBLE GASES AND HEAT OF REACTIONS

<u>Fuel Mixture</u>	<u>Moles of Gas/100g</u>	<u>Heat of Reaction at 77°F, cal/g</u>
50 Mg/50 Teflon	$4.73 \times 10^{-2}$	---
50 Mg/50 Teflon	$3.83 \times 10^{-2}$	---
50 Mg/50 Teflon	$4.09 \times 10^{-2}$	---
60 Mg/40 Teflon	$4.2 \times 10^{-2}$	---
60 Mg/40 Teflon	$3.9 \times 10^{-2}$	---
40 Mg/60 Teflon	$5.49 \times 10^{-2}$	1785
40 Mg/60 Teflon	$4.60 \times 10^{-2}$	1875
40 Mg/60 $KClO_4$	$7.63 \times 10^{-2}$	2300
Hyperstoichiometric		
40 Al/60 $KClO_4$	$2.44 \times 10^{-2}$	2100

To identify the effects of impurities such as water vapor and carbon content which could be introduced in the powder production process, we performed the gas measurement for different types of aluminum powder. Table XVI lists the noncondensable gases evolved from a 60%  $KClO_4$ /40% aluminum fuel mixture during constant-volume combustion experiments. These total moles were analyzed for composition by mass spectrometry. There are a number of conclusions which may be drawn from the data.

Ingredient preparation was a first-order variable influencing gas evolution. Removal of water from the aluminum powder by drying at 180°C and 10 mm Hg reduced the gas evolution by almost a factor of three. Another chemical factor, aluminum purity, appears to influence the gas production. LSA 250 is a high purity powder containing 99.995% aluminum. The other powders, except for Magna-Flake, were 99.5% aluminum. The Magna-Flake has not been analyzed. This material was tested because its thickness was less than one micron and we anticipated lowering the oxygen content of the evolved gases through better combustion efficiency.

TABLE XVI

NONCONDENSIBLE GASES EVOLVED FROM A 60%  $KClO_4$   
AND 40% ALUMINUM FUEL

Test No.	Al Data	Sample wt, grams	Gas Moles/g	Gas Analysis, mole %	Remarks
33	VM H-3	29.5	$2.80 \times 10^{-4}$	No Analysis	Al particle size 4.8 $\mu$
39	VM H-3 (Dried)	20.0	1.65	61.5 16.0 22.5	Al particle size 4.8 $\mu$
43	Magna-Flake	9.5	5.93	- 68.5 31.5	Al 20 $\mu$ 771 $\mu$ thick
44	Reynolds - 400	8.0	0.96	73.5 19.4 7.1	Al particle size 6.0 $\mu$
45	LSA-250	7.5	1.01	47.5 18.0 34.5	Al particle size 9.0 $\mu$
46	LSA-250 (Dried)	15.0	0.34	- 42.6 51.3 6.1	Al particle size 9.0 $\mu$

However, this material was contaminated with a lubricant used in grinding, probably stearic acid, so its carbon content was considerably higher than the other powders. The carbon apparently is a contaminant from the carbon electrodes and carbon pot linings used in the electrolytic manufacture of aluminum. The mass spectrometry results would place the carbon content of the 99.5% aluminum powders in the range of 0.08%.

#### b. Ignition and Combustion Characteristics

The investigation of the combustion behavior of fuel pellets containing potassium perchlorate and aluminum has established that incomplete consolidation in some pellets caused by either high porosity or internal fracture can lead to a rapid deflagration during burning. This behavior was observed when we attempted to measure the burning rates of some typical pellets produced in our Stokes pill press.

This high porosity appears to be characteristic of pellets with densities below 2.25 g/cc. Such behavior may be a problem with all powdered fuels. Since a binder is not used in the magnesium/potassium perchlorate fuel pellets, these may exhibit similar behavior. This cannot be determined experimentally because of the difficulty in pressing a low density pellet which would stay compacted.

The ignition temperature of aluminum/potassium perchlorate pellets was found to be in excess of 1100°C. Magnesium/Teflon and magnesium/potassium perchlorate pressed tablets ignite in the range from 610°C to 620°C. The importance of this is twofold. A higher ignition temperature increases the probability of pellet break-up from thermal shock since thermal expansion is greater. Differential thermal analysis showed that during the heating process potassium perchlorate begins to decompose at about 650°C. This decomposition alters the stoichiometry between reactants and leads to inefficient combustion.

The burning rates of pressed pellets of Al/KP, Mg/KP and Mg/Teflon were measured at atmospheric pressure in an oxyacetylene flame by dropping them into a heated carbon crucible. Temperatures in the range of 1400°C were attained in the crucible.

#### c. Fuel Pellet Characterization

Efforts to obtain low density pellets of Al/KP from the Stokes pill press were unsuccessful because consolidation becomes poorer as the pressing pressure is lowered. As a result we weighed and made density measurements on a large number of pellets to establish the density variation associated with the variability in pellet weights which come from the present process. This relationship is shown in Fig. 6. By weighing all pellets we separated the population into a high density (> 2.3 grams/cc) fraction and a low density (< 2.25 grams/cc) fraction which were used in the combustion characterization experiments. The resulting pellet was approximately 0.75 inch dia. x 0.200 inch thick.

It was not possible to press Mg/KP nor Mg/Teflon mixtures in the Stokes pill press because the powder feeder did not put sufficient material into the die to give the same dimensions as the Al/KP pellet. Consequently, another die in a manually operated press was used to make pellets 1/2 inch dia. by 1/2 inch long to study the effect of both size and composition. All three candidate fuels were pressed to this size for use in the combustion experiments designed to measure ignition delay, burn time, and sensitivity to detonation.

#### d. Combustion Characterization

Low density pellets pressed from KP/Al powder to the size 0.75 inch dia. by 0.200 inch thick weighed in the range from 2.7377 to 3.0994 grams. When combusted in a 3 inch dia. by 4 inch long carbon crucible heated to 1400°C by an oxyacetylene torch directed at the top of the

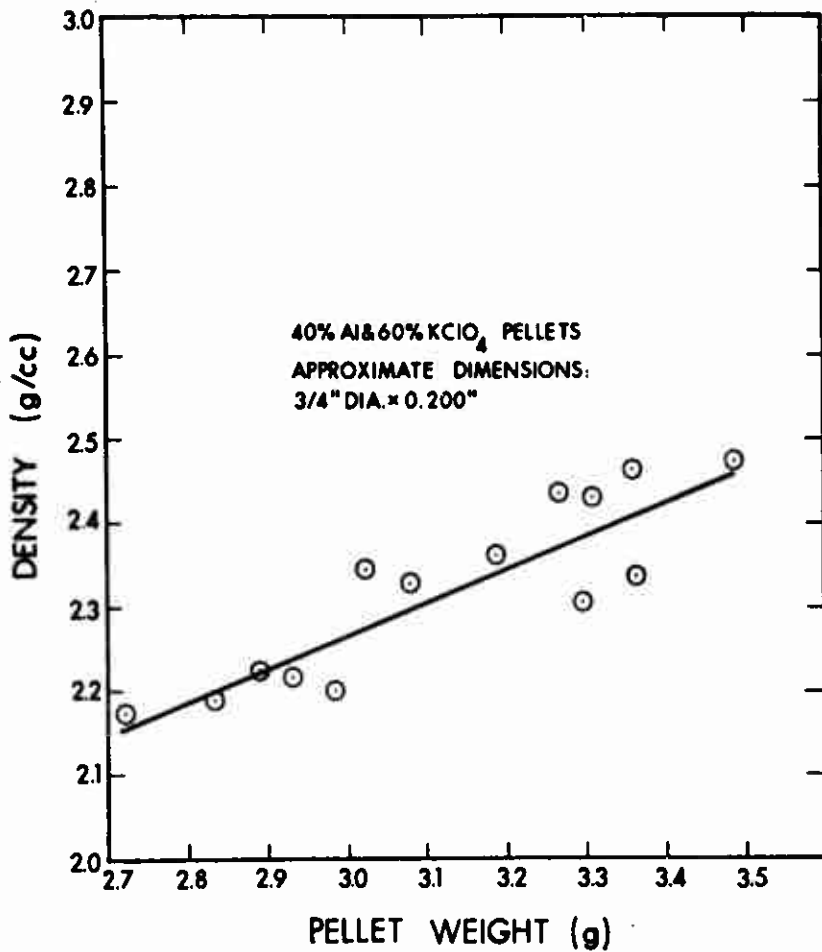

Figure 6. Density versus Pellet Weight

crucible, the mean pellet burn time was 4.65 seconds with a sample standard deviation of 0.48 second. Burning time was measured as the duration of light output indicated by a photocell. Four of twelve pellets in this weight range transitioned from normal combustion into rapid deflagrations with high rates of energy release typical of explosions. High speed photography of pellets falling through the gaseous combustion zone proved that ignition delay plays an important role in the combustion phenomenon. A normal burning pellet appears to ignite as soon as it begins to fall through the oxyacetylene flame. In abnormal combustion behavior shown by some low density pellets, a partial detonation was observed as the first evidence of ignition. This occurred after an ignition delay which was appreciably longer than that observed in normal burning.

To evaluate the effect of the oxyacetylene combustion gases upon pellet combustion, the carbon crucible was heated to  $1400^{\circ}\text{C}$  by directing the flame at the bottom of the crucible. Ten low density pellets were burned without a detonation. However, the burn times varied over the range from 1.68 to 5.93 seconds. This was indicative of poor combustion stoichiometry, probably brought about by the slow cook-off of  $\text{KClO}_4$  before ignition. The result of such behavior is shown in Fig. 7. This pellet was dropped on a hot brick which was at  $1100^{\circ}$  as measured by an optical pyrometer. The thermal shock caused the stress cracking shown in the photograph. The pellet did not ignite. The residue analyzed 21.7%  $\text{KCl}$ , 19.3%  $\text{KClO}_4$ , 6.4%  $\text{Al}_2\text{O}_3$  and 5.7% aluminum with the remainder suspected to be  $\text{KClO}_3$ . These experiments show conclusively that a long ignition delay (indicative of a high ignition temperature) will cause the following undesirable effects: high enthalpy accumulation leading to possible detonation-like combustion, premature decomposition of  $\text{KClO}_4$  leading to poor combustion efficiency, and gaseous products.



Figure 7. Partially Decomposed Aluminum/Potassium  
Perchlorate Fuel Pellet

Eight high density pellets (weights varying from 3.3115 to 3.5177 grams) were burned without a detonation in the carbon crucible heated by directing the oxyacetylene flame at the top. The average burn time was one second longer than that for the low density pellets, 5.68 seconds with a standard deviation of 0.53 second.

Our previous work on gas evolution from the alternate fuels Mg/Teflon and Mg/KP showed that both ignited more easily but evolved more gas than did Al/KP. Their combustion behavior was investigated using 1/2 inch dia. by 1/2 inch long pressed pellets of all three fuels. These were burned in the top-heated crucible at 1400°C. No combustion abnormalities were noted. The burning times and sample weights are shown in Table XVII. The 1/2 inch by 1/2 inch Al/KP pellets were pressed to the same density as the high density 0.75 inch by 0.200 inch pellets used in previous experiments.

TABLE XVII  
FUEL PELLET BURNING TIMES

<u>Composition</u>	<u>Sample No.</u>	<u>Mean Burn Time, sec</u>	<u>Standard Deviation, sec</u>	<u>Mean Weight, grams</u>	<u>Standard Deviation, grams</u>
40% Al, 60% KClO <sub>4</sub>	24	5.68	0.53	3.415	0.103
40% Mg, 60% Teflon	18	5.25	0.75	3.195	0.009
40% Mg, 60% KClO <sub>4</sub>	20	2.53	0.44	3.205	0.012

We observed during disposal operations that powdered Al/KP fuel consistently burned to detonation in layers as thin as 1/4-inch. Since a number of low density pellets were found to be unconsolidated in the center, this observation further supported our theoretical explanations for an accidental explosion; i.e., thermal break-up exposed powdered fuel which deflagrated at a very high rate. We also found that these low density pellets are easily detected, and rejected, by weighing.

#### e. Ignition Characterization

Auto ignition temperatures were determined for all three fuel candidates by dropping small pieces of pressed pellets into a molten Wood's metal or aluminum bath at increasingly higher temperatures. Figures 8 and 9 are plots of ignition delay versus temperature for Mg/Teflon and Mg/KP. The auto ignition temperature is determined by extrapolating the curves to zero ignition delay. Mg/KP ignites at  $620^{\circ}\text{C}$  and Mg/Teflon at  $610^{\circ}\text{C}$ . The ignition temperature of Al/KP is appreciably greater than  $1100^{\circ}\text{C}$ . At this temperature the heating elements of our apparatus repeatedly burned out so we discontinued the experiments.

#### f. Conclusions

It appears from our experiments that the cause of the partial detonation of the Al/KP pellet observed early in the program can be attributed to three factors: high ignition temperature, poor consolidation, and a rapid heat-up rate in passing through the oxyacetylene flame. Ignition temperature may be lowered by changing the fuel composition to either Mg/KP or Mg/Teflon at the sacrifice of increasing the gas evolution and lowering the heat output. It may also be possible to minimize these deficiencies while lowering the ignition temperature by adding magnesium to the Al/KP composition. The rejection of low density pellets with poor consolidation can be done simply by weighing them. If these two factors are controlled, the rapid heating to be expected in the prototype reactor will not cause combustion abnormalities. In fact, we did not experience any combustion difficulty in the heat transfer experiment using high density Al/KP pellets without Mg additives.

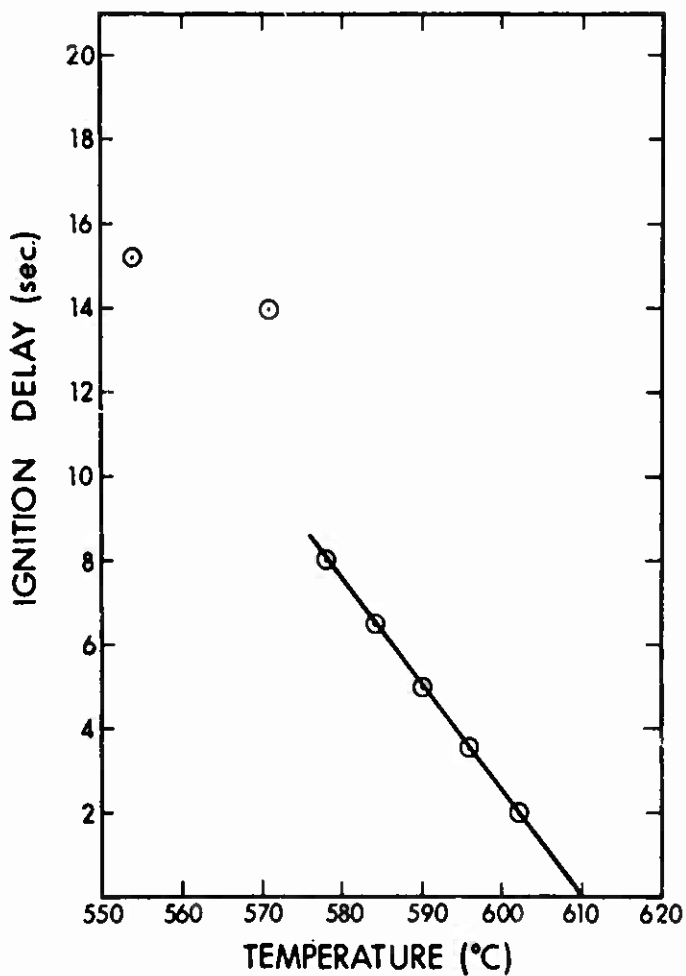

Figure 8. Ignition Delay of Magnesium/Teflon Pellets versus Temperature

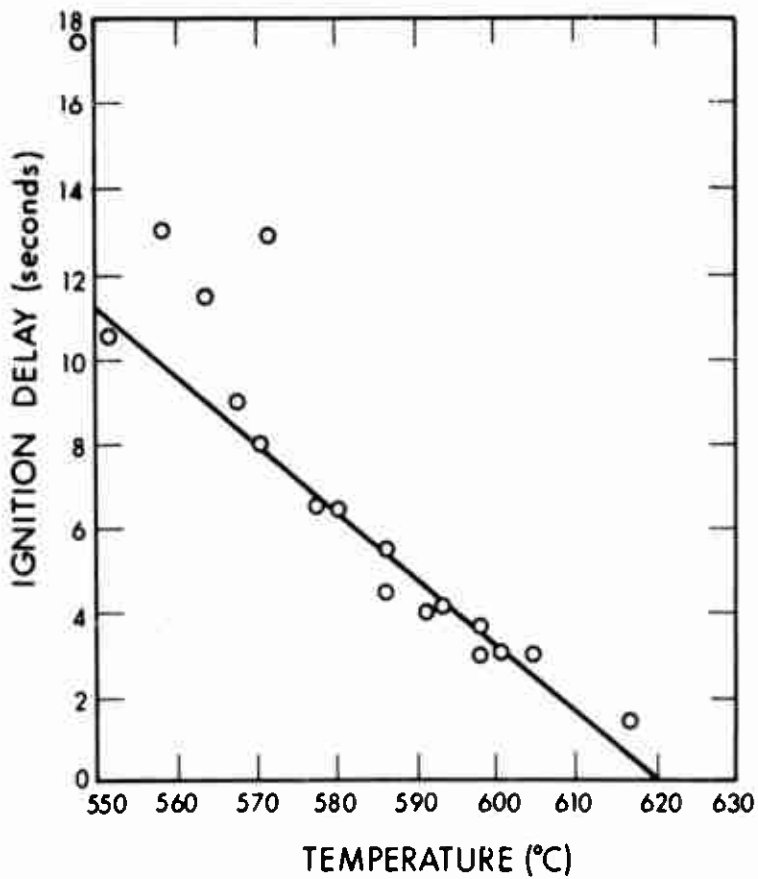

Figure 9. Ignition Delay of Magnesium/Potassium Perchlorate Pellets versus Temperature

## 5. HEAT TRANSFER EXPERIMENT

The heat source investigation was concluded with the heat transfer experiment. The fundamental questions that these experiments were to answer were: Will the combustion temperature and the heat flux derived from the chemical reaction be compatible to the thermionic conversion requirements, and what are the combustion efficiency and the mode of heat transfer? These are primary objectives. In addition, the secondary objective was to monitor the reactor pressure while combustion was in progress.

In the following subsections we will describe the development of the fuel, igniter, and test hardware and finally the experimental results (raw data). The analysis and evaluation of experimental data are reported in Section III.

### a. Fuel Development

A process has been developed to produce fuel pellets compatible with the tape feed proposed for the feasibility experiments. The pellets for the tape feed device contained 60% potassium perchlorate and 40% aluminum. Approximate dimensions are 0.75 inch diameter by 0.205 inch thick. The as-received potassium perchlorate was prepared by grinding it in a hammer mill to a mean particle diameter of 9 microns. This material was dried for 48 hours at 100°C at 0 mm Hg pressure before blending with the aluminum powder. The Reynolds 1-131 aluminum used in the fuel pellet has a mean particle diameter of 6 microns, and was also dried for 48 hours at 100°C under vacuum before blending. The powders were blended by shaking them in a 1-gallon paint can under an inert atmosphere of nitrogen to prevent absorption of atmospheric water. Pellets were pressed in a Stokes pill press to a density of about 2.5 grams/cc.

A number of methods of attaching the fuel pellets to the feed tape were investigated. Although gluing appeared to be the most direct approach, any organic residue would contribute to gas evolution. We decided to use the double tape as a carrier as shown in Fig. 10. Two strips of stainless steel tape, 1 inch wide by 2 mils thick, were spot welded at sufficient intervals to form pockets into which the fuel pellets fit tightly. Two spreader bolts were used to split the tapes and drop the pellets into the reactor as the tape is taken up by a driven drum.

#### b. Igniter Development

Start-up of the thermal reactor utilizing the tape feed mechanism requires an absolutely reliable igniter. The tape containing the fuel pellets must be in motion before ignition to prevent its being burnt through, thereby stopping the pellet feed. This can lead to flash-back into the feed drum with subsequent deflagration of all pellets stored in the drum. Reliable ignition of the 40% Al/60%  $KClO_4$  fuel pellet is made difficult by its high ignition temperature ( $> 1100^\circ C$ ).

The addition of magnesium to the basic fuel composition has been found to lower the ignition temperature significantly. Pellets containing 3.40% and 8.93% magnesium were tested by the method described previously. These percentages amount to 10 and 25%, respectively, of the stoichiometric amount of fuel required to burn the potassium perchlorate to completion. The remaining fuel required is aluminum, which is used in excess by 6.6% to ensure complete combustion of the potassium perchlorate. The ignition delay times of these mixtures versus temperature are plotted in Fig. 11. The zero-delay ignition temperatures for the fuel pellets containing 3.40% and 8.93% magnesium are  $895^\circ C$  and  $849^\circ C$ , respectively.

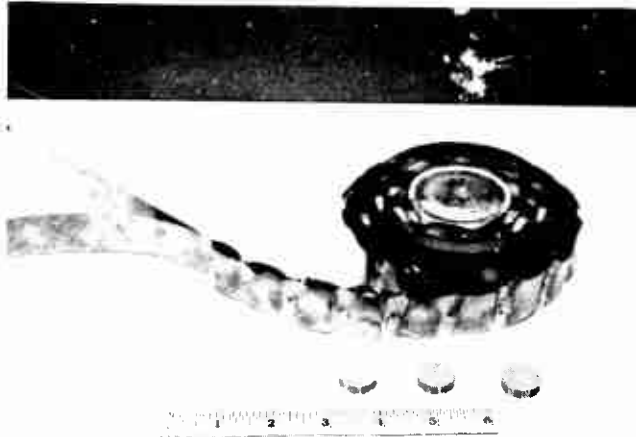

Figure 10. Fuel Pellets and Feed Tape

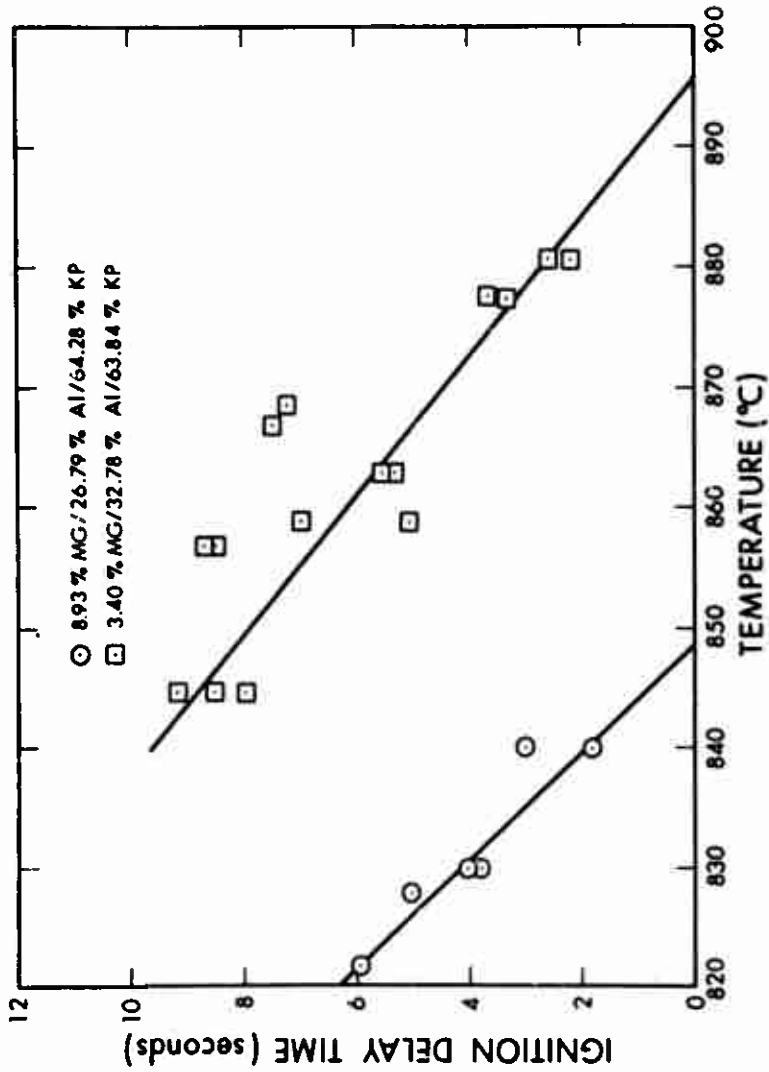

Figure 11. Ignition Delay Times of Al/KP Fuel as a Function of Mg Additive

Since the increase in magnesium content from 3.40% to 8.93% gave a difference in ignition temperatures of only  $46^{\circ}\text{C}$ , a preliminary batch of fuel pellets containing 3.40% magnesium was pressed for igniter tests in the steel reactor. Initial experiments at atmospheric pressure in open containers confirmed that these pellets ignite more easily.

All ignition experiments in a closed reactor system with the fuel pellets containing magnesium to lower the ignition temperature resulted in over-pressurization and burst diaphragm failure when the pressure reached an unanticipated value of 1000 psig. This high pressure condition could not be explained except that we suspect that impurities in the magnesium powder or reaction with the carbon content in steel could easily account for the pressure. As a result we decided to use our early fuel mixture of 60% potassium perchlorate (ground to 9 microns average diameter) and 40% aluminum (Reynolds 1-131) in the heat transfer experiments. The delay time experienced with this igniter during development testing ranged from 2.8 to 3.0 seconds. Figure 12 is a sketch of the igniter. It burned in the range from 2.5 to 3.0 seconds and generated less than one atmosphere pressure when cooled to ambient temperature in our heavy duty steel reactor.

#### c. Hardware Development

The original objective was to conclude the experiment by measuring the steady-state rate of heat transfer by means of a radiation calorimeter. As work progressed it became apparent that the radiation calorimeter approach was not compatible with funds and time available. It was decided to perform a transient experiment employing a thick-walled reactor which was also used in preliminary ignition and pressure measurements.

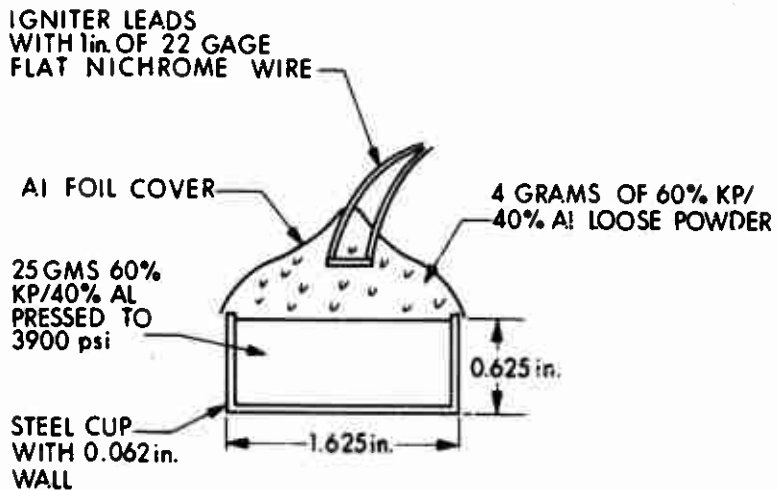

Figure 12. Fuel Igniter Configuration

Two heavy duty reactors were fabricated; one was made of mild steel, and the other from forged tungsten billet. The steel reactor was to be used in the early experiments to gain experience in the operation of the igniter and feed mechanism. It was anticipated that as the operating time is lengthened, the tungsten reactor will be required since the wall temperature will be high, exceeding the service temperature of steel. Both reactors have identical dimensions and they can be equipped with the same fuel feed system.

The heavy duty steel reactor is equipped for feeding solid fuel pellets as shown in Fig. 13. The take-up drum with drive motor is on the left. The feed drum is on the right. The lead-in ports are water-cooled to reduce the possibility of excessive heat build-up in the feed assembly. Fuel pellets are charged to a double thickness of 1 inch wide by 2 mil thick stainless steel feed tape which is drawn through the reactor by the motor-driven take-up reel; two stationary posts inside the reactor split the tape and allow the fuel pellets to drop inside. Initially chamber pressure was indicated by two pressure gages, the low range by a Taber absolute pressure gage ( $P_{C1}$ ) calibrated from 0 to 1 atmosphere, and the high range by a Taber strain gage ( $P_{C2}$ ) calibrated to 500 psia. In later experiments, the lower pressure gage was eliminated. Thermocouples indicating the gas temperatures ( $T_c$  and  $T_s$ ) and the reactor temperatures ( $T_1$ ,  $T_2$  and  $T_3$ ) were installed as shown in Fig. 14. An event marker taken from the voltage to the igniter wire was used to show when the feed tape was started. The feed rate was then calculated from the known feed drum speed.

#### d. Experimental Results

Initial tests were made at tape speeds of 1 inch and 12 inches/second. At the lower speed the fuel ignited inside the tape causing a flashback into the feed drum. When there is no igniter malfunction, the higher tape speed results in satisfactory ignition and burning.

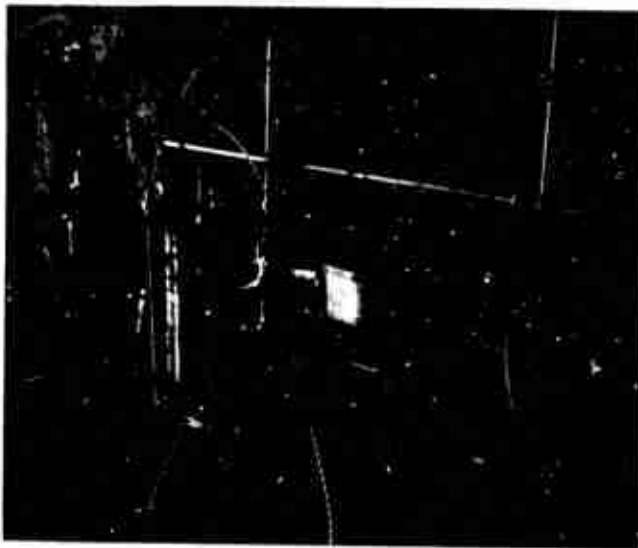

Figure 13. Steel Reactor Setup for Ignition and Combustion Experiments

<u>SYMBOL</u>	<u>THERMOCOUPLE</u>	<u>ACCURACY</u>
$T_1, T_c$ & $T_5$	W-26Re VS. W-5Re	$\pm 1\%$ (0-2000°C)
$T_2$ & $T_3$	CHROMEL VS. ALUMEL	$\pm 1\%$ (0-1000°C)

PRESSURE GAGE

TABER INST. MODEL 206  $\pm 1/2\%$  (0-500 psi)

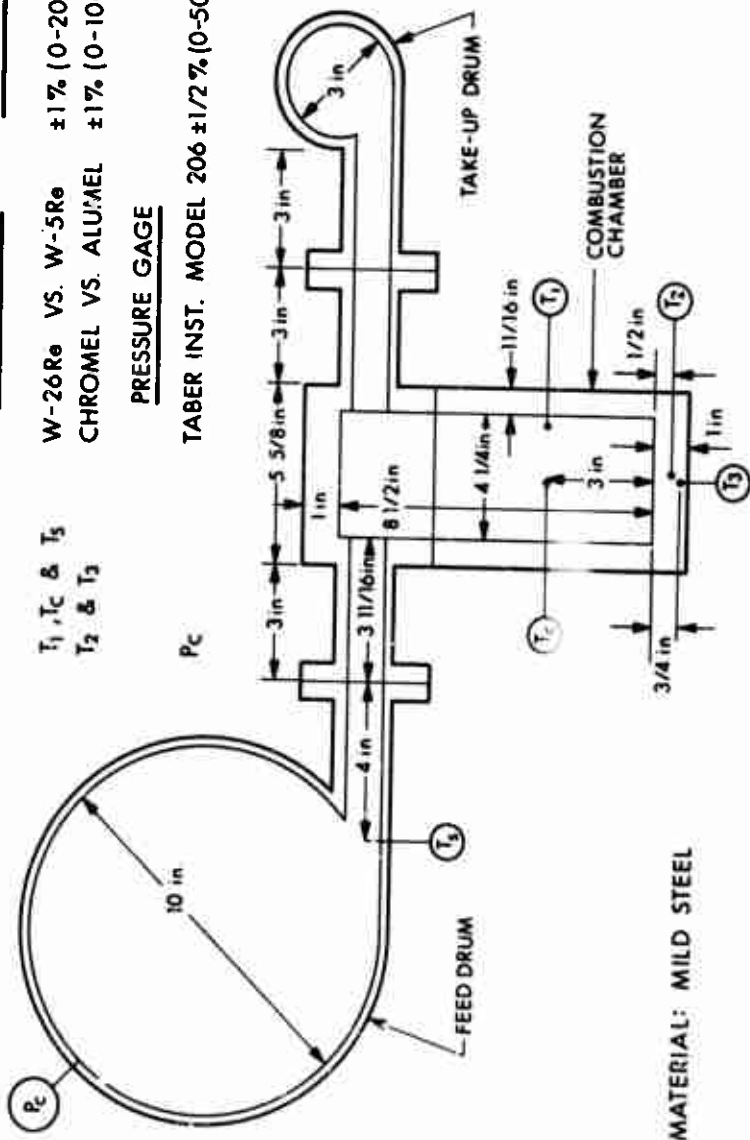

Figure 14. Instrumentation for Heat Transfer Equipment

Figure 15 shows data from the oscillograph record of a successful ignition. After an ignition pressure surge of 213 psia the reactor pressure decreased to 40 psia. Pellet feed rate was 2 per second or 6 g/sec. This amounts to an approximate heat input rate of 12,000 cal/sec. However, thermal, and therefore pressure, equilibrium was not attained because of the short 7-second run time. Another test made to extend the run time by feeding more pellets, failed due to an exceedingly long ignition delay of 10 seconds. When ignition occurred all 50 pellets in the tape had been charged to the reactor. These ignited all at once and caused our pressure safety release mechanism to rupture.

All further efforts to extend our run time beyond approximately 7 seconds usually ended in a pressure failure which upon analysis of the burning record could be attributed to a mismatch between the arrival of pellets in the reactor and the functioning of the igniter. For example, in Test 7 (firing record in Fig. 16), fuel feed started 2.2 seconds before the igniter started to function. However, the gas temperature as indicated by the thermocouple inside the reactor started to increase another 1.8 seconds later. As a result 37.2 grams (12 pellets) of fuel were charged to the reactor before ignition was fully developed. Feed stopped when the tape burned through after 18 pellets were charged. The run was programmed for 25 pellets. We theorized that the ignition of such a large amount of fuel in the reactor probably ignited a pellet in the feed tube leading from the drum to the reactor.

Test 9 was to be a duplicate of Test 7, except the start of fuel feed was programmed to occur closer to the predicted functioning time of the igniter. The firing record in Fig. 17 indicates that we achieved this and fuel started only one second before ignition started. However, the thermocouple inside the reactor indicated a gas temperature increase 2.2 seconds later. Thus 31 grams of fuel were charged before ignition was fully developed. Again the tape burned through and fuel feed stopped. However, this time the fuel in the feed drum ignited and caused the drum

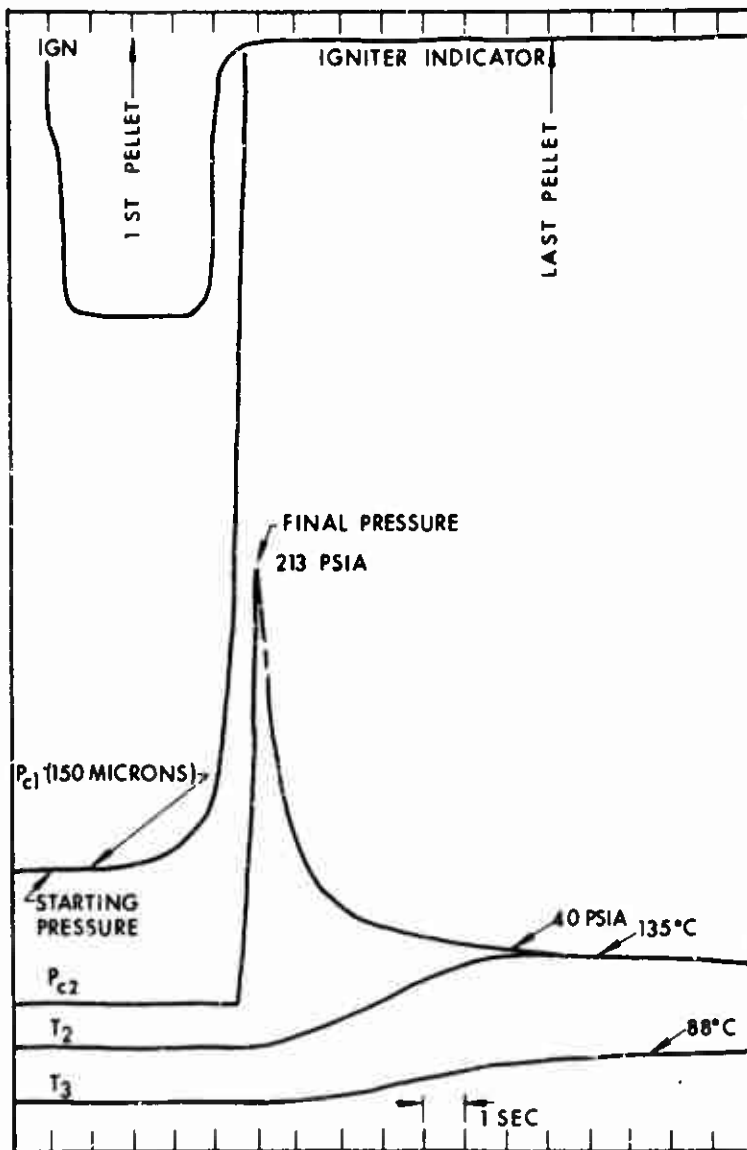

Figure 15. Oscillograph Record of Test 4 - Al/KP Pellet Feed

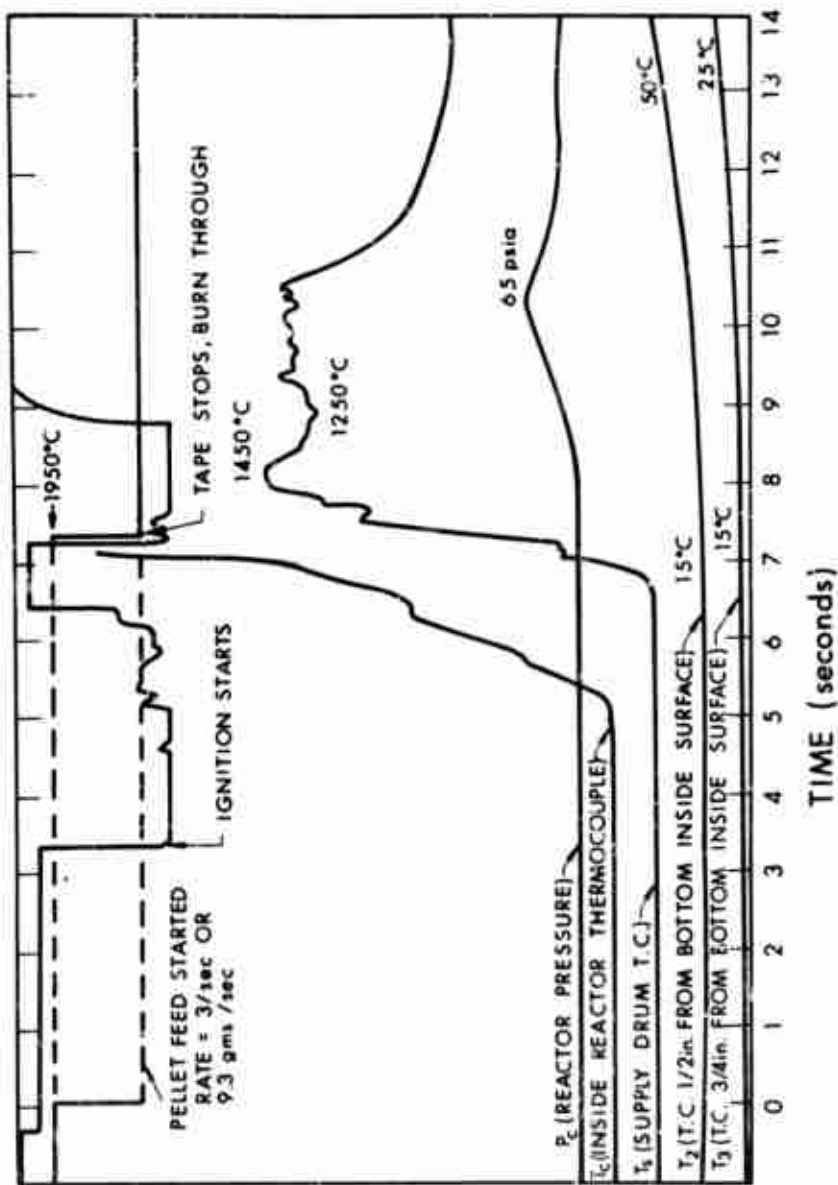

Figure 16. Heat Transfer Test 7 Firing Record

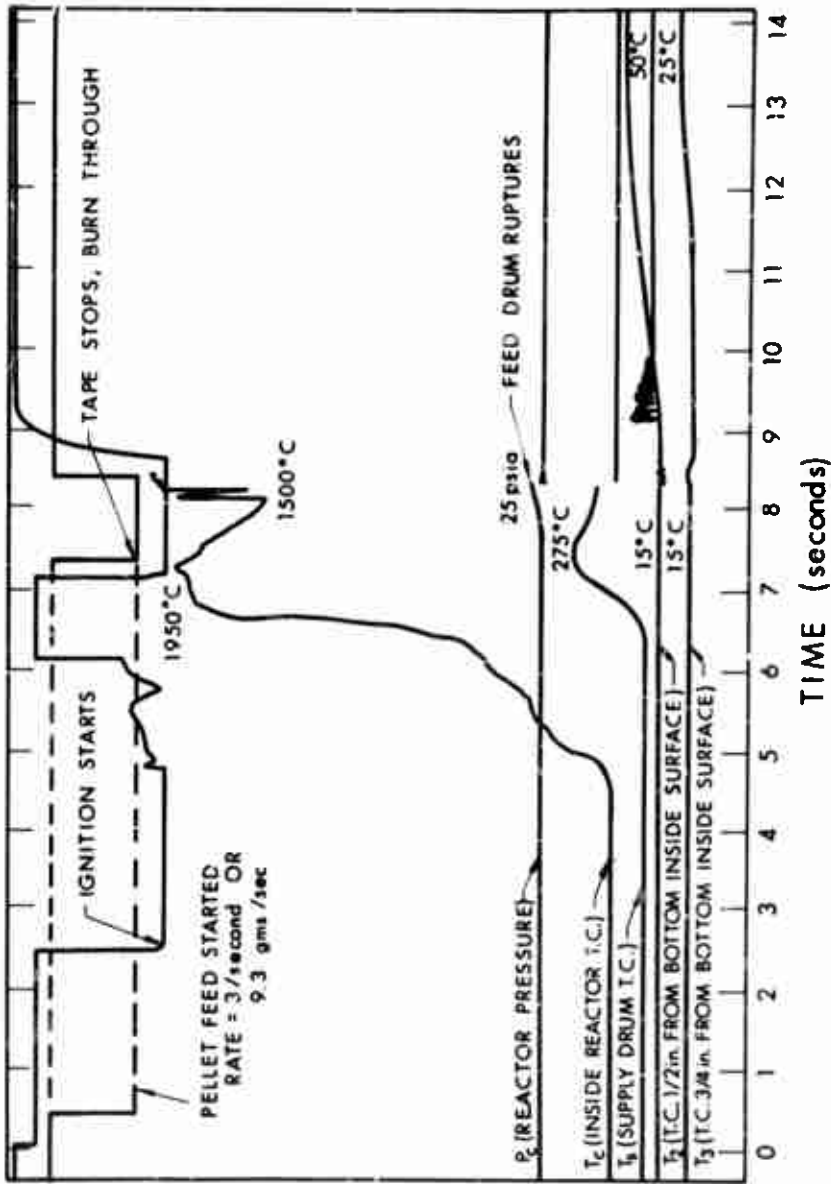

Figure 17. Heat Transfer Test 9 Firing Record

to rupture. Since the lack of funds precluded rebuilding the feed drum for another test, we attempted to achieve our measurement of the heat transfer rate by changing to a liquid fluorocarbon slurry fuel containing 62.24% FC-43 liquid fluorocarbon, 35.71 magnesium powder (-325 mesh), and 2.05% powdered Teflon (TFE #7, DuPont).

The feed ports for the tape mechanism were blocked off with blind flanges. A slurry injector orifice 0.019 inch in diameter was installed in the top closure of the reactor. This was fed from a 2 inch diameter by 6 inch long stainless steel slurry tank through a 1/4 inch ball valve which could be remotely actuated to shut down the firing sequence. The valve was programmed to be closed either by excessive pressure in the reactor or by emptying of the slurry feed tank. Feed rate was controlled at 9.3 g/sec by pressurizing the tank to 150 psig with nitrogen. Figure 18 is the firing record for this test. Ignition was normal and the reactor pressure began to increase upon initiation of the slurry feed. When the pressure reached 105 psia the feed tube from the tank to the injector ruptured from an over-pressure and terminated the test. This was caused when the flame apparently flashed back through the injector and ignited the feed stream. Since the calculated feed velocity of 600 in./sec was appreciably above the slurry burning rate (roughly 2 in./sec), the flashback may have been caused by either a flow stoppage or overheating of the injector, causing ignition behind the orifice. Another possibility is that burning proceeded from the deflagration velocity to detonation velocity. However, since the flame did not propagate into the slurry tank, this appears remote.

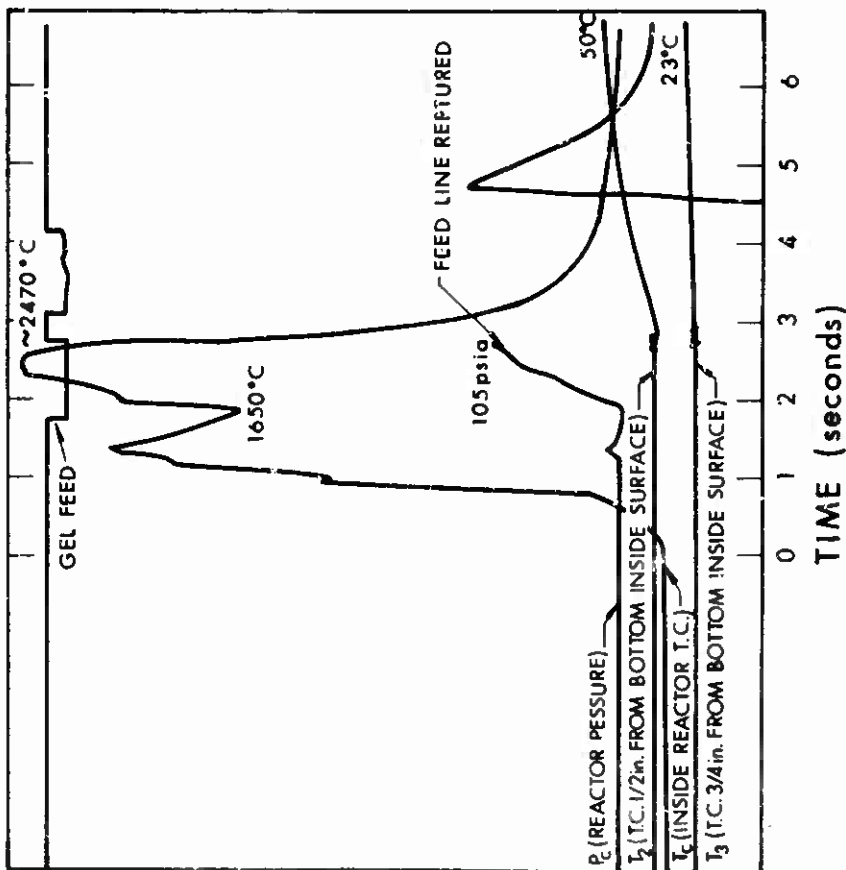

Figure 18. Heat Transfer Test 10 Firing Record

**BLANK PAGE**

## SECTION III

### MATERIALS COMPATIBILITY INVESTIGATION

An experimental investigation of the compatibility between containment and chemical heat source materials was completed. The scope of the investigation was limited to containment materials which are considered state-of-the-art (i.e., this was not to be a materials development effort) and also limited to the products of the reaction rather than the components of the reaction themselves, which require a special handling capability.

The reaction products were prepared by SRI during the course of the fuels selection task. The aluminum/potassium perchlorate reaction was selected during this task and therefore the reaction products were also selected. An analysis of reaction products was performed by SRI and is reported as follows: Potassium chloride - 35 w/o, aluminum - 6 w/o, and aluminum oxide - 59 w/o.

The investigation was comprised of four main efforts: container material considerations, container fabrication and processing, high temperature experiments, and postoperation examinations. The following sections discuss these efforts in more detail and summarize the investigation. Recommendations are included in the last section.

#### 1. SELECTION OF CONTAINER MATERIAL

As a starting point in any materials compatibility investigation, a suitable containment material must be selected. In this study, the requirement of extremely high temperature (i.e., 1700°C) narrows the field of selection to only the few highest melting point refractory metals. Moreover, some metals may be rejected, a priori, because of availability or cost. Osmium and ruthenium belong in this category. Two metals,

tantalum and niobium, which are abundant and possess high melting points, are rejected from another standpoint; namely, they absorb oxygen in great quantities at temperatures as high as 1800°C. This phenomenon could conceivably deprive the reaction of oxygen, thereby preventing the reaction altogether or at least diminishing the heat of reaction to minimal values.

Two metals, tungsten and rhenium, appeared the most promising. They have the highest known melting points of the metals, their oxides are volatile; that is, while they react with oxygen they do not dissolve or absorb it. Tungsten is quite plentiful and rhenium, though once considered semi-precious, has recently become more abundant in supply and less costly. The main problem with these materials is one of fabrication. The next section discusses the procedures of shaping, joining, and processing these metals.

## 2. CONTAINER FABRICATION AND PROCESSING

Chemical vapor deposition is a process in which the halide compound of metal is reduced either by hydrogen or pyrolytically on a disposable mandrel. The halide compounds of tungsten and rhenium are typically gaseous hexafluoride or pentafluorides. Two vapor-deposited tungsten crucibles were purchased from San Fernando Laboratory, Inc., a supplier of metal vapor depositions. The crucibles are shown in Figs. 19 and 20 with an integral pumpout lid. The purpose of the pumpout lid was to provide a means of attachment for vacuum outgassing. The wall thicknesses of the crucibles and tubing were nominally 0.060 inch. A single tube of vapor-deposited rhenium was also purchased. The rhenium capsule thickness was 0.020 inch.

The first tungsten crucible was electron beam welded to a pumpout lid, loaded with one gram of combustion products from the aluminum/potassium perchlorate reaction and mounted in a high speed vacuum system. The crucible was outgassed at 600°C for approximately 10 minutes in a vacuum

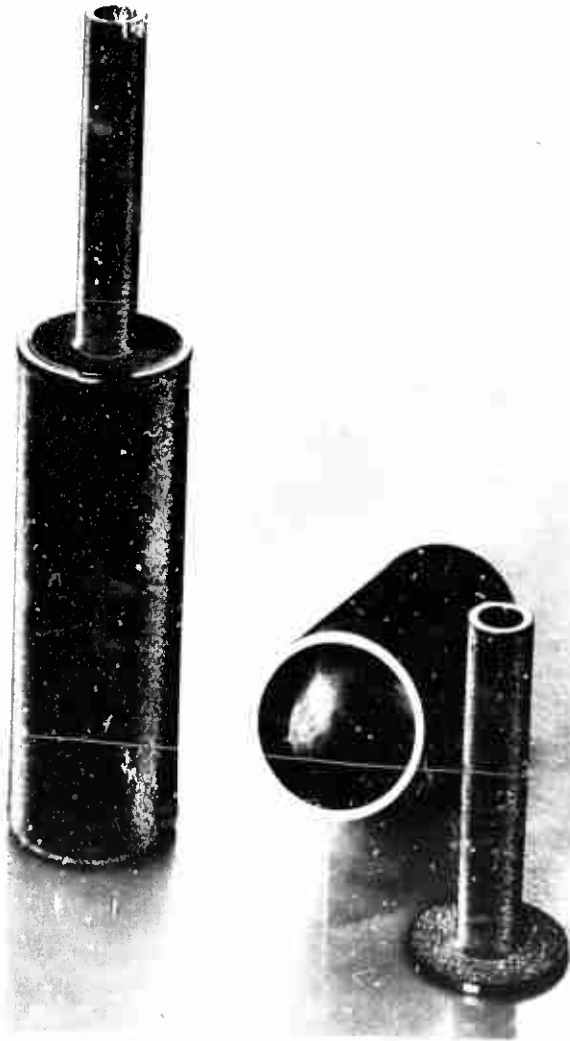

Figure 19. Vapor-Deposited Tungsten Container

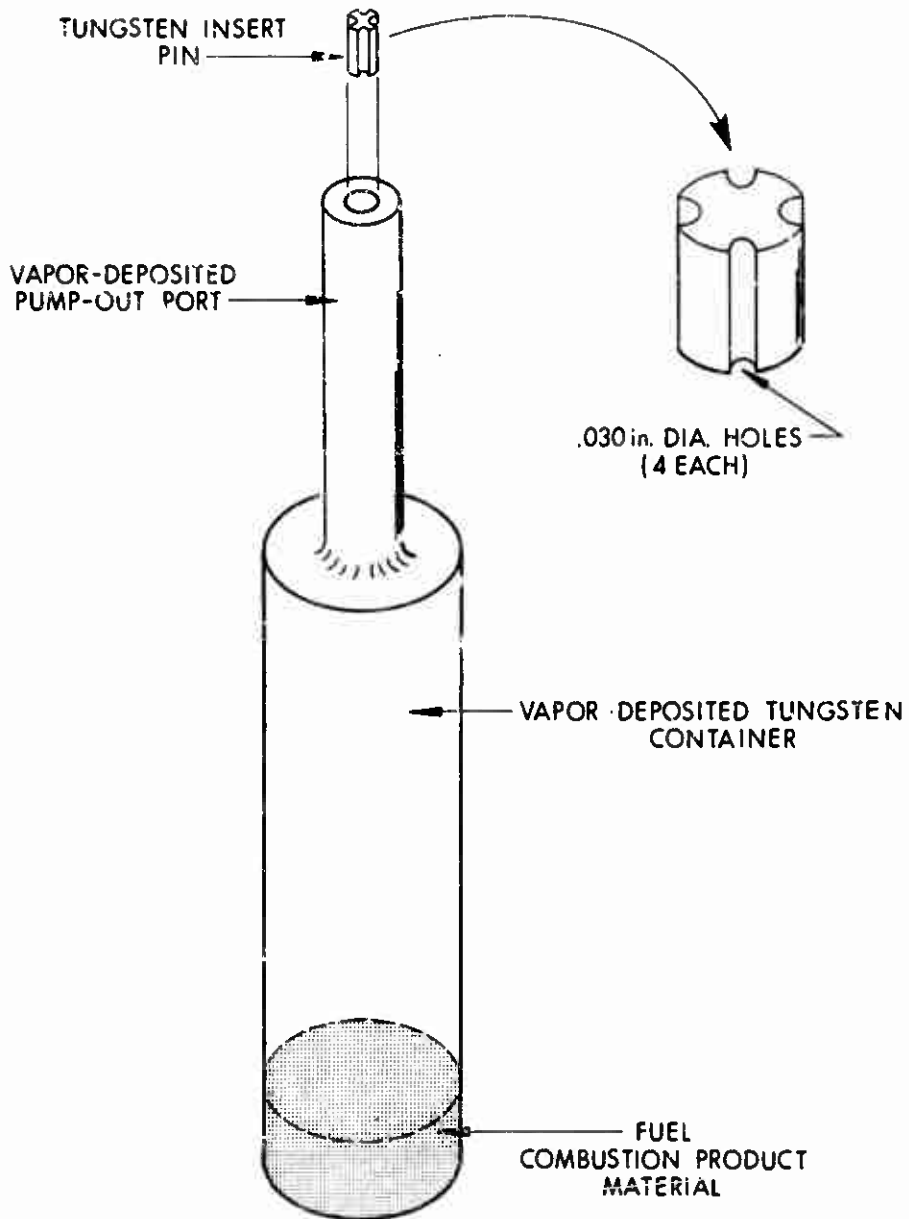

Figure 20. Vapor-Deposited Tungsten Container Loaded with Fuel Combustion Products Prior to Final Welding

environment of  $10^{-7}$  torr. Employing a vacuum manipulator a tungsten plug was inserted into the crucible after the outgassing cycle. The plug was subsequently titanium-brazed into the pumpout port. The key element of this sequence is that after outgassing, the container is sealed in vacuo without removal. It was realized that brazing was only an interim process before a welding procedure was devised.

The second tungsten crucible was electron beam welded to a pumpout lid in the same manner as was the first crucible. This time, however, after loading the crucible with one gram of combustion products, the crucible and insert plug were returned to the electron beam welder. The insert plug was provided with four slots, 0.030 inch in diameter as shown in Fig. 20. The purpose of the slots was to allow pumpout of the crucible before welding them shut. The crucible was preheated to approximately  $600^{\circ}\text{C}$  for 10 to 15 minutes to insure that the combustion products were free from occluded gas and water vapor. The seal-off pressure in the electron beam welder was  $1 \times 10^{-5}$  torr. Closure was accomplished by melting and flowing tungsten over the slots. The resultant structure was therefore entirely welded and consequently stronger and of higher reliability than the first container. The rhenium crucible was fabricated by joining the vapor-deposited rhenium tube to two rhenium disks. The joining was effected by electron beam welding. One disk was slotted, as in the case of the previous tungsten crucible, the other disk was solid. The processing, loading, and final sealing cycle was identical so that of the second tungsten crucible. In the instance of a slotted plug or disk, the evacuating time is purposely extended to compensate for the reduced pumping conductance of the slots.

### 3. HIGH TEMPERATURE EXPERIMENTS

All three containers were heated by an RF induction heating unit capable of 20 kW output. The heating was accomplished in a quartz jar evacuated by a high speed vacuum system. Temperatures were measured with a

micro-optical pyrometer sighted on the container surface. Appropriate corrections were applied to obtain the true temperature. However, this correction is highly dependent upon surface conditions and is at best accurate to within  $\pm 35^{\circ}\text{C}$ .

The first tungsten container was operated at  $1500^{\circ}\text{C}$  (true), instead of the design temperature of  $1700^{\circ}\text{C}$ , to allow for the titanium braze point. The braze failed after 20 minutes at temperature as indicated by a leak check after termination of the experiment. There was no visible evidence of attack on the container walls.

The second tungsten container was operated at  $1700^{\circ}\text{C}$  (true) for a period of 30 minutes. The container was opened and leak checked. The container walls were prepared for metallographic examination, the results of which are discussed in more detail in the next section.

The rhenium container was operated at  $1800^{\circ}\text{C}$  (true) for 30 minutes. The metallographic examination of the container is discussed in the next section.

#### 4. POST-OPERATION EXAMINATION

All three containers were metallographically examined for the degree of interaction, if any, between the reaction products and container. Figures 21 and 22 are photomicrographs of the vapor-deposited tungsten containers and there is no evidence of attack. These photographs were typical of several regions of each container; hence the conclusion that for the period of time and temperature of operation, there was no evidence of interaction between the containers and reaction products. During the sample preparation, the brittle nature of recrystallized tungsten was evidenced. Several samples cracked during the cutting and potting operations. The lack of ductility in tungsten is well known and places a limitation on its use where mechanical load or excessive thermal shock is experienced.

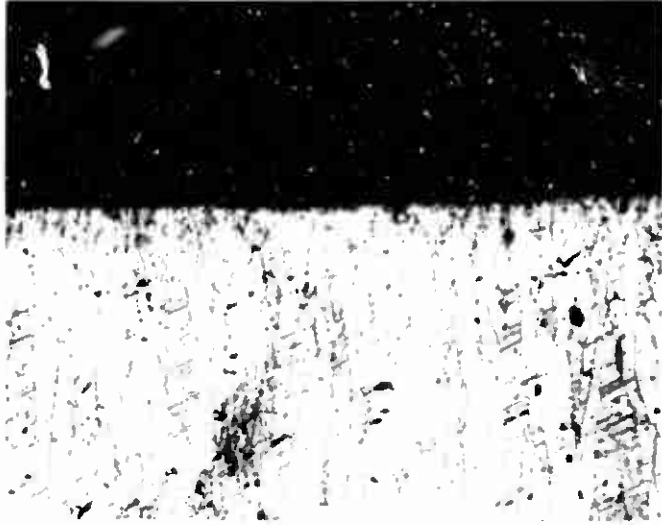

Figure 21. 200X Photomicrograph of Vapor-Deposited Tungsten Crucible after 18 Minutes Operation at 1500°C



Figure 22. 200X Photomicrograph of Vapor-Deposited Tungsten Crucible after 30 Minutes Operation with Fuel Byproducts at 1700°C. No Evidence of Attack.

Figures 23, 24, and 25 are photomicrographs at different magnifications of the same area of the vapor-deposited rhenium container. The depth of the reaction zone, as depicted in the photographs, is 0.0015 inch deep. It should be recalled that the rhenium container was operated at a temperature 100°C higher than was the vapor-deposited tungsten container. The internal pressure was also calculated to be five times that of the tungsten case. These two factors could account for attack in one case but not the other. At any rate, the amount of interaction should be considered as minimal relative to the total wall thickness.

#### 5. SUMMARY

Three separate high temperature experiments and postoperational examinations concluded the materials compatibility investigation. Results of the investigation are summarized in Table XVIII. Of the two containment metals, vapor-deposited rhenium is the recommended material. Although the tungsten appeared more resistant to reaction, it presents problems from a ductility standpoint. It is anticipated that any large thermal shock, such as might be experienced by a pyrochemical heat source ignition cycle, could conceivably fracture tungsten. Rhenium on the other hand appeared relatively inert and is quite ductile. While there is a difference in cost between vapor depositions of tungsten and rhenium, the majority of the cost is in the deposition process itself which includes tooling, setup and labor. The effect of cost difference will therefore be minimal when a large quantity fabrication is involved.

Electron beam welding appears to be the most satisfactory method of joining and processing container geometries of vapor-deposited rhenium (and tungsten). Throughout the investigation, all electron beam welds remained leak tight.

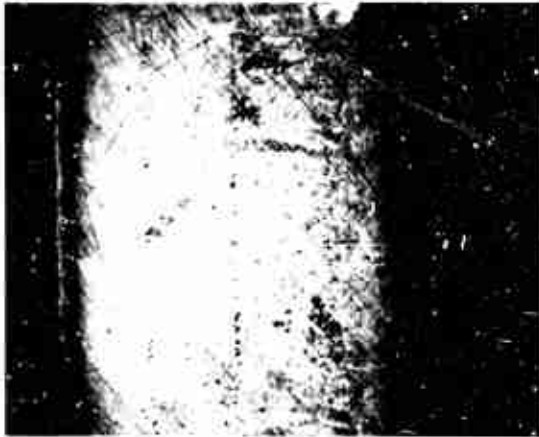

Figure 23. Reaction Zone (0.0015 in.) of Vapor-Deposited Rhenium and Byproducts of Aluminum/Potassium Perchlorate (Mag: 110X)



Figure 24. Reaction Zone (0.0015 in.) of Vapor-Deposited Rhenium and Byproducts of Aluminum/Potassium Perchlorate (Mag: 220X)

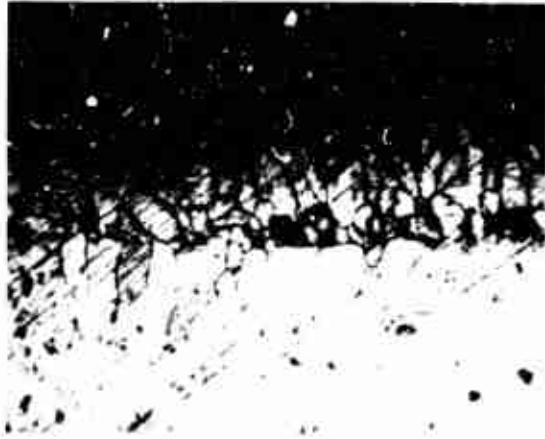

Figure 25. Reaction Zone (0.0015 in.) of Vapor-Deposited Rhenium and Byproducts of Aluminum/Potassium Perchlorate (Mag: 660X)

**TABLE XVIII**  
**SUMMARY OF RESULTS MATERIALS COMPATIBILITY STUDY**

Test No.	Container Material	Temperature (°C)	Calc. Pressure (psi)	Time at Temp. (Minutes)	Degree of Attack	Remarks
1	Vapor-Deposited Tungsten	1500	265	20	No detectable penetration and diffusion zone	Closure by vacuum brazing
2	Vapor-Deposited Tungsten	1700	300	30	No evidence of attack	Closure by eb welding
3	Vapor-Deposited Rhenium	1800	1460	30	Less than 1.5 mils penetration	Closure by eb welding

- Notes: (1) Tungsten container dimensions are 1" diameter x 3" length x 0.060" wall thickness.  
 (2) Rhenium container dimensions are 1/2" diameter x 1-1/4" length x 0.020" wall thickness.  
 (3) All tests are performed with combustion products of aluminum/potassium perchlorate fuel. Chemical analysis showed the following contents: 6% Al; 35% KCl; 59% Al<sub>2</sub>O<sub>3</sub>.  
 (4) Capsule heating is by means of an R.F. coil.

**BLANK PAGE**

SECTION IV  
SYSTEM CONCEPTUAL DESIGN

The work in the system conceptual design task was divided into the following subtasks:

- Analysis and evaluation of experimental heat transfer data
- Conceptual design utilizing experimental data
- Performance analysis of the pyrochemical thermionic generator concept

1. ANALYSIS AND EVALUATION OF EXPERIMENTAL DATA

a. Test Run 9

The analysis will be based on the data of Test Run 9 whose chronological events are shown in Fig. 26. For this run, 29 grams of Al/KP pressed into a steel cup was used as the igniter. Ignition was initiated one second after the first fuel pellet (also of Al/KP) was dropped into the reactor. After 2.2 seconds (and 10 pellets), the thermocouple monitoring the combustion flame temperature began to rise indicating that the igniter had started the combustion. The flame temperature rose rapidly, reaching  $1950^{\circ}\text{C}$  in 2.9 seconds. (This represented a heating rate of  $665^{\circ}\text{C}$  per second.) At this point, the intense radiation caused the feed tape to burn through and thereby stopped the feed. Eighteen pellets were fed into the reactor.

We can summarize the significant factual events which will be used in the analysis as follows:

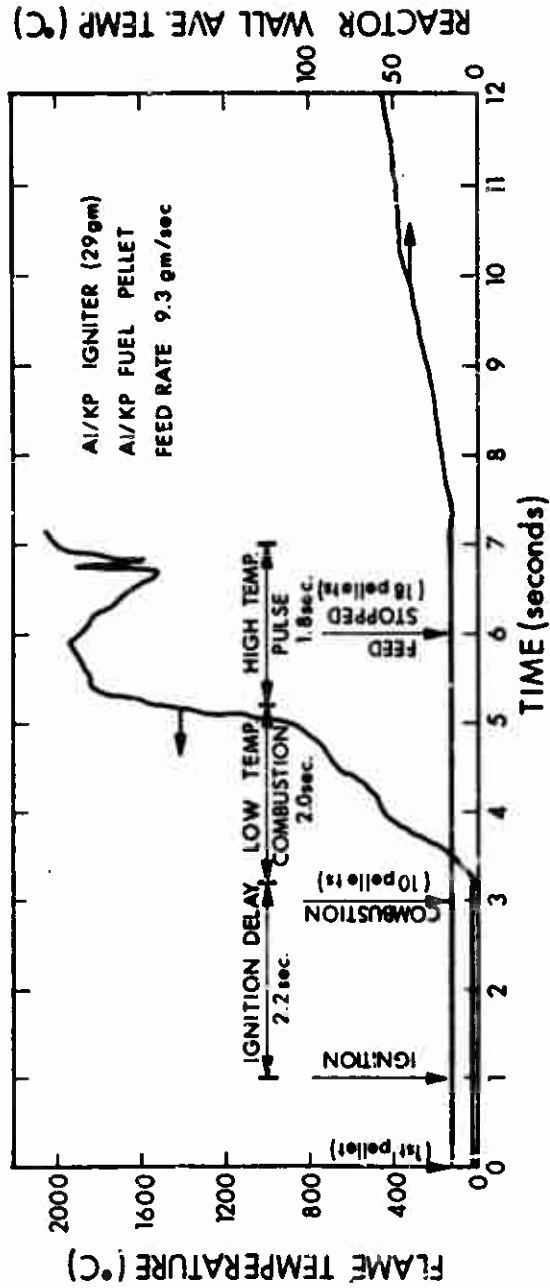

Figure 26. Time History and Chronological Events of Test Run No. 9

- The temperature history shown in Fig. 26 was a result of the energy released from 29 grams of igniter and 55.7 grams of fuel pellets (18 pellets at 3.1 grams each).
- The total energy yield minus the energy required to bring the combustion products to 1950°C will be the net energy available for heat transfer purposes. This is represented by a 1.8-second high temperature pulse as indicated in Fig. 26.
- Because of the short duration of the pulse, the heat received at the reactor wall inner surface did not have sufficient time to diffuse to the outside surface. In other words, the reactor behaved as if it were insulated with no heat loss. This was evidenced by the thermocouple placed at the middle of the wall. To the first approximation, the net energy released was responsible for the wall temperature rise.

We will use the above described facts to perform the following:

- Determine the combustion efficiency by calculating the net energy output and comparing it with the energy responsible for the wall temperature rise.
- Postulate a radiation heat transfer model and calculate the heat flux at the combustion chamber wall. A combustion efficiency computed from this heat flux will provide a check on the validity of the model.
- Compare the heat flux and flame temperature achieved in the heat transfer experiment with those required by a full-scale pyrochemical thermionic generator.

#### (1) Combustion Efficiency

The stoichiometric mixture of 34.2% Al and 65.8%  $KClO_4$  has a theoretical yield of 2450 cal/gm. In our experiment, a hyperstoichiometric fuel of 40% Al and 60  $KClO_4$  was employed. The measured energy yield at room temperature is 2100 cal/gm. (If we assume that the energy output is proportional to the aluminum content the measured value has an excellent correlation with the theoretical yield, i.e.,  $34.2/40 \times 2450 = 2100$ .) The measured energy will be used in computing the combustion efficiency.

If the combustion is brought to completion the energy balance can be stated as follows:

$$\left[ \begin{array}{l} \text{Energy yield} \\ \text{at room temperature} \end{array} \right] - \left[ \begin{array}{l} \text{Energy required to} \\ \text{raise combustion} \\ \text{products to } 1950^{\circ}\text{C} \end{array} \right] = \left[ \begin{array}{l} \text{Net energy output} \\ \text{from combustion} \\ \text{flame} \end{array} \right] \quad (1)$$

$$\text{Also, } \left[ \begin{array}{l} \text{Net energy output} \\ \text{from combustion flame} \end{array} \right] = \left[ \begin{array}{l} \text{Energy received by reactor wall,} \\ \text{causing its temperature rise} \end{array} \right] \quad (2)$$

By combining Eqs. 1 and 2 and stating it mathematically, we have,

$$M_f (E_y - E_{cp}) = M_r C_{pr} \Delta T \quad (3)$$

where  $M_f$  = weight of the fuel and the igniter, grams  
 $E_y$  = measured energy yield, cal/g  
 $E_{cp}$  = energy required to raise the combustion products to  $1950^{\circ}\text{C}$ , cal/g  
 $M_r$  = weight of the steel reactor plus feed system, grams  
 $C_{pr}$  = specific heat of the reactor wall material  
 $\Delta T$  = the reactor wall temperature rise from ambient,  $^{\circ}\text{C}$

If the combustion is not complete, we define the combustion efficiency as,

$$\eta_c = \frac{M_r C_{pr} \Delta T}{M_f (E_y - E_{cp})} \quad (4)$$

The term  $E_{cp}$  can further be expanded as a function of combustion product species, e.g.,

$$E_{cp} = \sum_i (E_{cp})_i \quad (5)$$

$$(E_{cp})_i = \left[ C_p(s) \Delta T_s + \Delta H_m + C_p(l) \Delta T_l + \Delta H_v + C_p(g) \Delta T_{g_{\infty}} \right] i \quad (6)$$

where  $P_i$  = weight fraction of the  $i^{\text{th}}$  species of the combustion products

$\Delta H_m, \Delta H_v$  = heats of fusion and vaporization, cal/g

$C_p(s), C_p(l), C_p(g)$  = average heat capacity in the solid, liquid, and gas phases, cal/g- $^{\circ}$ K

$\Delta T_s, \Delta T_l, \Delta T_g$  = temperature rise in the solid, liquid, and gas regions, respectively

For the Al/KP system, the weight fractions of the combustion products were: 6% Al, 35% KCl, and 59%  $Al_2O_3$ . In the temperature range of this experiment, solid aluminum melts at  $933^{\circ}$ K and remains in liquid form with essentially no gas at  $1950^{\circ}$ C. KCl undergoes two phase changes: it melts at  $1044^{\circ}$ K and boils at  $1700^{\circ}$ K.  $Al_2O_3$  remains solid up to its melting point of  $2030^{\circ}$ C. We shall calculate  $E_{cp}$  for these components from the materials properties compiled.

Aluminum:

$$\begin{aligned} [E_{cp}]_{Al} &= C_p(s)\Delta T_s + \Delta H_m + C_p(l)\Delta T_l \\ &= 0.26(933 - 298) + 90 + 0.31(2223 - 933) \\ &= 650 \text{ cal/g} \end{aligned}$$

Potassium chloride:

$$\begin{aligned} [E_{cp}]_{KCl} &= C_p(s)\Delta T_s + \Delta H_m + C_p(l)\Delta T_l + \Delta H_v + C_p(g)\Delta T_g \\ &= 0.237(1044 - 298) + 84.5 + 0.237(1700 - 1044) + 306 \\ &\quad + 0.125(2223 - 1700) \\ &= 789 \text{ cal/g} \end{aligned}$$

Aluminum oxide:

$$\begin{aligned} [E_{cp}]_{Al_2O_3} &= C_p(s) \Delta T_s \\ &= 0.285 \times (2223 - 298) \\ &= 569 \text{ cal/g} \end{aligned}$$

$$\begin{aligned} E_{cp} &= \sum P_i [E_{cp}]_i \\ &= 0.06 \times 650 + 0.35 \times 789 + 0.59 \times 569 \\ &= 650 \text{ cal/g} \end{aligned}$$

The net energy released per gram of fuel and igniter is

$$E_y - E_{cp} = 2100 - 650 + 1450 \text{ cal/g}$$

The fuel pellets and igniter weighed 84.7 grams. The combined weight of the reactor and feed system was computed to be 50 lb. The temperature rise, as indicated by the thermocouple, was between 40° to 45°C. Using the lower value, the combustion efficiency is,

$$\begin{aligned} \eta_c &= \frac{M_C \Delta T}{M_T (E_y - E_{cp})} \\ &= \frac{(50 \text{ lb})(454 \text{ g/lb})(0.12 \text{ cal/g-}^\circ\text{K})(40^\circ\text{K})}{(84.7\text{g})(1450 \text{ cal/g})} \\ &= \frac{1.10 \times 10^5 \text{ cal}}{1.23 \times 10^5 \text{ cal}} \\ &= 0.9 \end{aligned}$$

The calculated efficiency of 90% is quite conservative, since the feed system (10 lb) was made with a much thinner section. It will be heated up faster than the reactor vessel. However, the thermocouple monitored the reactor average temperature. In actuality, the combustion efficiency should approach 100%.

## (2) Heat Transfer from Combustion Gas to Reactor Wall

We shall postulate that the heat transfer from the combustion gas to the reactor wall is primarily by thermal radiation. We shall test this hypothesis by calculating: (1) the radiation heat flux, (2) the rate of heat transfer, and (3) the energy transfer. The last will provide a check on the validity of the model when the energy transfer is compared to the input energy derived from the exothermic reaction.

For the case of the flame filling the combustion chamber, the emissive property of the combustion gas depends on the gas pressure. This behavior is clearly shown in Fig. 27 for the combustion of a benzene-air mixture at 1760°C. With increasing pressure, the radiation from the gas approaches that of a blackbody.

In our heat transfer experiment, the hypothesis of the reacting gas filling the combustion chamber is supported by the apparent flashback and the uniform reaction products deposition on the wall found after each run. Since the pressure was estimated to be in the neighborhood of 25 to 35 atm, the gas body can be assumed to behave like a blackbody.

The rate of heat transfer from the gas to wall is, to a first approximation, given by

$$Q = P \epsilon_w \sigma A_w (T_f^4 - T_w^4) \quad (7)$$

where  $Q$  = rate of heat transfer, watts

$P$  = empirical factor of less than 1 indicating the closeness to the blackbody

$\epsilon_w$  = emissivity of the wall to be evaluated at the wall temperature

$\sigma$  = Stefan-Boltzmann constant =  $5.67 \times 10^{-12} \frac{\text{watts}}{\text{cm}^2 \text{ } ^\circ\text{K}^4}$

$A_w$  = area of the wall,  $\text{cm}^2$

$T_f$  = flame temperature,  $^\circ\text{K}$

$T_w$  = wall temperature,  $^\circ\text{K}$

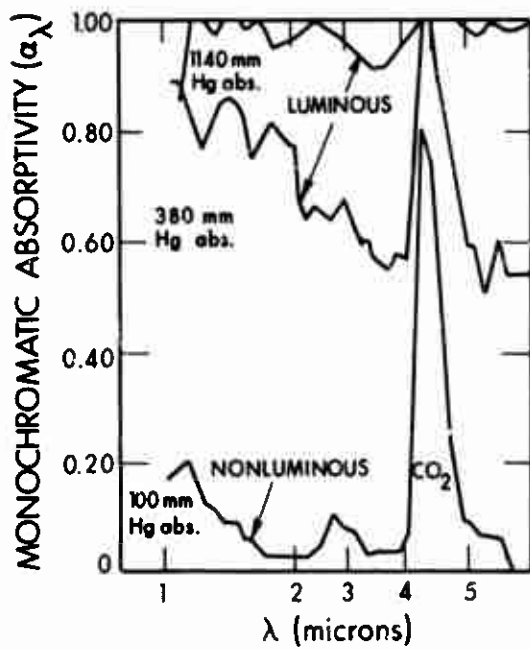

Figure 27. Monochromatic Absorptivity of Luminous and Nonluminous Benzene-Air Flames at 1760°C (after Miller, et al, Ref. 13)

We shall assume that P is about 0.95.  $T_w$  was approximately 373°K. The emissivity of the wall will be that of the steel vessel covered with reaction products deposit. The surface was found to exhibit a dark gray color. Although the emissivity of  $Al_2O_3$  (a likely deposit during the reaction) is about 0.75 at this temperature, we will assume the emissivity to be 0.8 since the deposited surface was very rough. A flame temperature of 2100°K will be used in the calculation. This is the fourth-power average or the temperature trace during the high temperature reaction period.

The heat flux is then,

$$\begin{aligned}
 q_w &= \frac{Q}{A_w} = P e_w T (T_f^4 - T_w^4) \\
 q_w &= 0.95 \times 0.8 \times 5.67 \times 10^{-12} [(2100)^4 - (373)^4] \\
 &= 85 \text{ watts/cm}^2
 \end{aligned} \tag{8}$$

Since the combustion gas filled the combustion chamber proper and the feed drum, the wall surface area must be the total internal surface which was computed to be 2740  $cm^2$ .

The rate of heat transfer to the wall is then,

$$Q = q_w A_w = 85 \times 2740 = 2.32 \times 10^5 \text{ watts}$$

Since the average duration of the high temperature reaction was about 1.8 seconds, the net energy transfer during this period will be,

$$E = \int Q dt = 1.8 \times 2.32 \times 10^5 = 4.20 \times 10^5 \text{ watt-sec}$$

The combustion efficiency based on the heat transfer model can be computed from,

$$\eta_c = \frac{\int Q dt}{M_f(E_y - E_{cp})} \quad (9)$$

Substituting

$$\begin{aligned} \eta_c &= \frac{4.20 \times 10^5 \text{ watt-sec}}{1.23 \times 10^5 \text{ cal} \times 4.18 \text{ watt-sec/cal}} \\ &= 0.82 \end{aligned}$$

In comparison with the  $M_C \Delta T_p$  method, this is a good correlation, since a 2-percent error in temperature measurement could have accounted for the difference. We conclude that the mode of heat transfer is primarily by radiation.

### (3) Heat Flux and Flame Temperature Requirements for a Full-Scale Pyrochemical Thermionic Generator

Having established the radiation mode of heat transfer from the flame to the combustion chamber wall, we shall determine the heat flux and flame temperature requirements for the thermionic generator. Early in the program it was anticipated that conduction and convection would be the modes of heat transfer with a rather large, localized heat flux. We also anticipated that the combustion chamber centerline temperature would be high, with a  $\Delta T$  of the order of  $1000^\circ\text{K}$ . To alleviate the localized heat flux problem, it was planned that the combustion chamber would be made from a double wall heat pipe to insure that the wall temperature is uniform. With the newly found information, i.e., the radiation transfer with combustion gas filling the combustion chamber, the localized high heat flux will not be present although a double wall heat pipe will still be required for heat flux transformation.

For reasonable combustion chamber dimensions of 8 cm in diameter and 30 cm long, the heat flux corresponding to a uniform heat removal

capacity of 37 kW will be about 49 watts/cm<sup>2</sup>. The required flame temperature, assuming the wall operating temperature of 1750°C, can be calculated from Eq. 8:

$$\begin{aligned} \dot{q}_w &= Pe_w \sigma (T_f^4 - T_w^4) \\ 49 &= 0.95 \times 0.8 \times 5.67 \times 10^{-12} [T_f^4 - (2023)^4] \\ T_f &= 2330^\circ\text{K} \end{aligned}$$

It is clear that the heat flux of 49 watts/cm<sup>2</sup> and flame temperature of 2330°K required for a steady-state operation are favorably comparable to the transient heat flux of 85 watts/cm<sup>2</sup> at the average flame temperature of 2100°K. Note that during this transient experiment the wall temperature was only about 373°K. Since the combustion chamber of the prototype generator will be thin, it will heat up quite rapidly. (The experimental reactor wall is from 3/4 to 1 inch thick.) As the wall temperature rises, the heat flux will be reduced, forcing the flame temperature to increase. Eventually, the required equilibrium conditions will be reached. We do not anticipate any difficulty in reaching the flame temperature of 2330°K since peak temperatures of 2223°, 2323°, and 2723°K had been demonstrated in test runs 7, 9, and 10.

b. Test Run 10

Data from test run 10 were analyzed using the same technique described previously. In run 10, magnesium/Teflon fuel was employed in the form of slurry. Results of the analysis indicated the following:

- Postulated radiation mode of heat transfer was again confirmed.
- The flame temperature reached a peak of 2723°K. The fourth-power averaged flame temperature for the pulse duration of 1.8 seconds was determined to be 2273°K.
- The corresponding heat flux was 115 watts/cm<sup>2</sup>.
- Combustion efficiency was greater than 90%.

### c. Estimate of Pressure

Pressure measurement during the transient heat transfer experiment was difficult because the instrument is acceleration sensitive and the change in pressure occurred at a rapid rate. However, the magnitude of pressure can be estimated from the safety release mechanism which was set at 500 psi. This was experienced in test run 9 when the feed drum was finally ruptured. This appeared to check with the calculated pressure of 484 psi, assuming that KCl dissociated completely into  $K^+$  and  $Cl^-$ . The pressure resulting from excess aluminum and aluminum oxide was negligible.

It should be noted that the high pressure condition was due to a rather high rate of energy release (232 kW). For the device designed to operate at 37 kW of steady operation, the pressure will be drastically reduced. The combustion chamber can be designed to withstand this reduced pressure without a significant weight penalty. However, a better solution will be to further reduce the pressure by providing a plate-out tank for KCl which will be kept at a temperature below its boiling point of  $1700^{\circ}K$ . This latter approach will be adopted.

## 2. CONCEPTUAL DESIGN

Three design concepts which evolved from three different fuel feed approaches will be presented.

### a. Generator Employing a Solid Bed Reactor

In the first approach, a solid bed reactor will be employed as the heat source. Figure 28 is a schematic drawing of the concept. The length of the fuel slug was based on a linear burning rate of 0.72 inch per minute of the aluminum/potassium perchlorate fuel, as determined

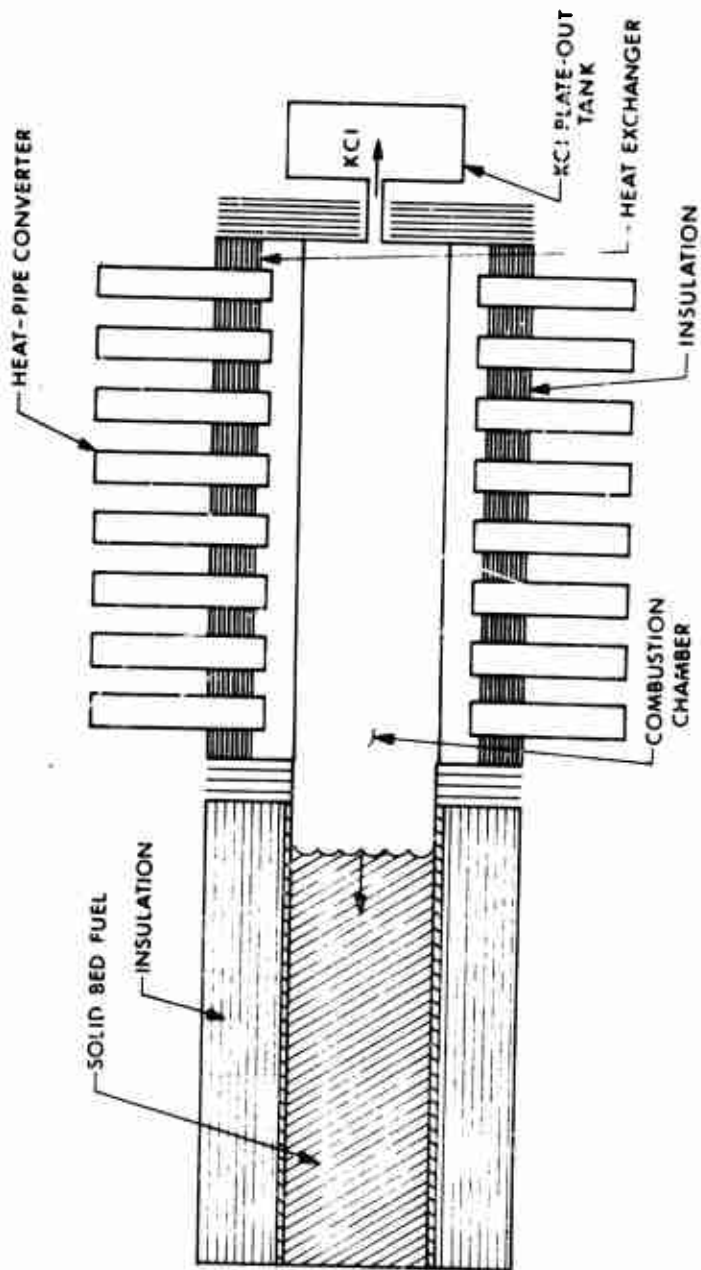

Figure 28. Generator Concept Using Solid Bed Fuel

from the combustion experiment. The Al/KP will be pressed into a ceramic-metal composite casing. The casing thickness will be sized to give sufficient strength and at the same time it must have a thermal characteristic to minimize the side conduction.

After ignition, the high temperature combustion products will tend to permeate the inside of a heat-pipe heat exchanger (also combustion chamber). Heat transfer from the hot reacting gas will be primarily by radiation. A small tank is provided for KCl to plate out at the other end of the heat exchanger. By proper sizing of the tank radiating area and its emissive coating, a surface temperature of 1400°C or less can be achieved, thereby insuring that KCl will plate out. Since KCl is the principal gaseous component (at temperature higher than 1500°C), the internal pressure can be kept at a minimum. Another advantage of this concept is that, with the advancing flame front, the increasing internal volume will tend to stabilize the pressure.

The overall length of the generator will be about 31 inches. For a longer operating time, the length of the generator must be increased at the rate of 0.72 inch per minute of operation.

Figure 29 shows the conceptual detail of the generator proper. Sixty-four thermionic converters are imbedded into a double-wall heat-pipe combustion chamber. The chamber consists of four annular segments which are separated by an insulation layer to alleviate the voltage hold-off problem. The converter is a heat-pipe type, both the emitter and collector/radiator structures. Figure 30 is a schematic of the heat pipe construction.

This concept appears to be very attractive, since no moving parts are required. However, further experimental work will be necessary since the burning rate data of a fuel slug of this size are not in existence. Furthermore, the burning rate used was based on the data obtained from

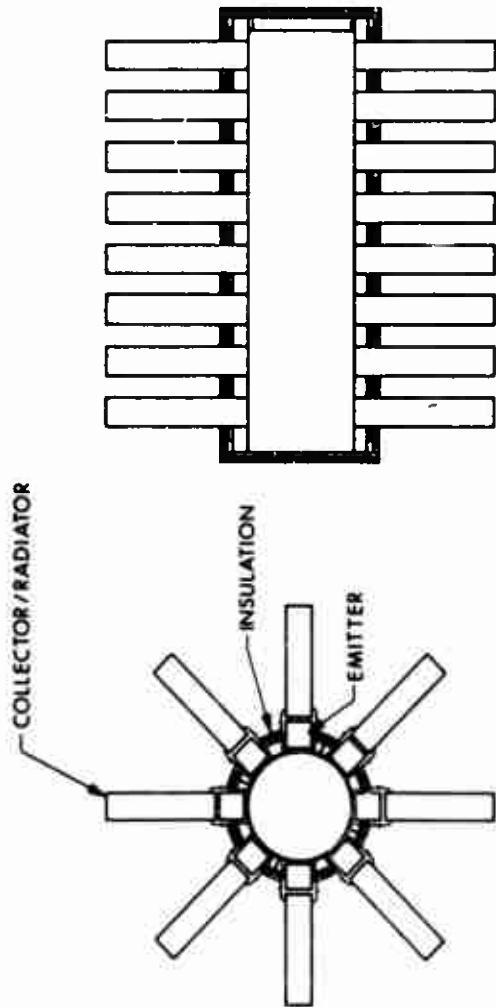

Figure 29. Conceptual Detail of Thermionic Generator

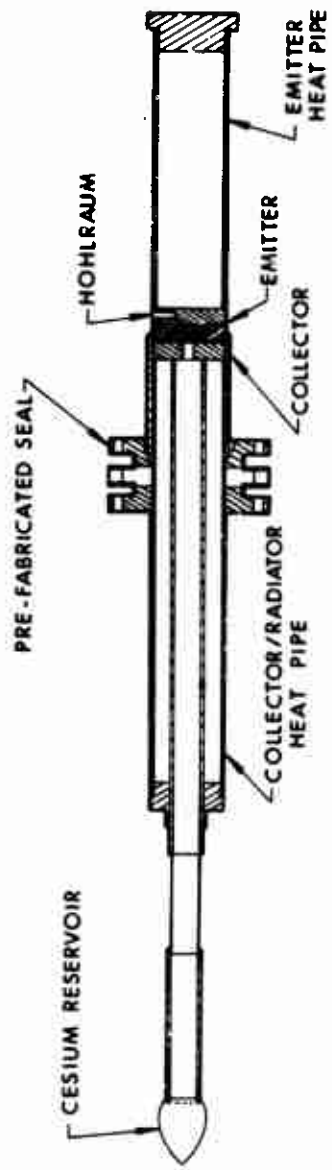

Figure 30. Design of Heat Pipe Converter

experiments performed at one atmosphere. If the pressure were to be higher (due to the possible ineffectiveness of the KCl tank), the burning rate could be increased by a factor of two. This would necessitate the use of a longer fuel slug, or perhaps a partial venting would be required.

b. Generator Employing Pellet Feed

Figure 31 shows a conceptual arrangement of this generator. The feed system will be a Gatling-gun type which consists of several barrels. The number of barrels and their length will be determined by the number of pellets required which, in turn, will be determined by the desired lifetime.

Each barrel will be loaded with pellets held in place with a release mechanism, and back loaded spring. Flashback of the combustion products is minimized by reducing the combustion pressure with the use of a KCl plate-out tank. In addition, the entire feed assembly will be kept under positive pressure of an inert gas, such as argon or nitrogen. Thermal conduction from the combustion chamber to the barrel will be minimized by a proper design of the heat exchangers. The barrel assembly will be rotated by a preprogrammed step motor. The rotation of the barrel after each pellet feeding reduces the time of contact with the feed port. As the barrel moves away from the port, it will be allowed to cool, thereby preventing the remaining pellets from reaching the autoignition temperature of  $1100^{\circ}\text{C}$ .

There are problems associated with this concept. First, the use of pellets will require a larger storage volume in comparison with the solid bed approach since the packing factor will be, at best, about 50%. Second, it requires moving parts and mechanisms which must be operated in a high temperature environment. In view of these factors, we consider this concept to be a third choice, rated behind the solid bed generator and the slurry feed concept to be described next.

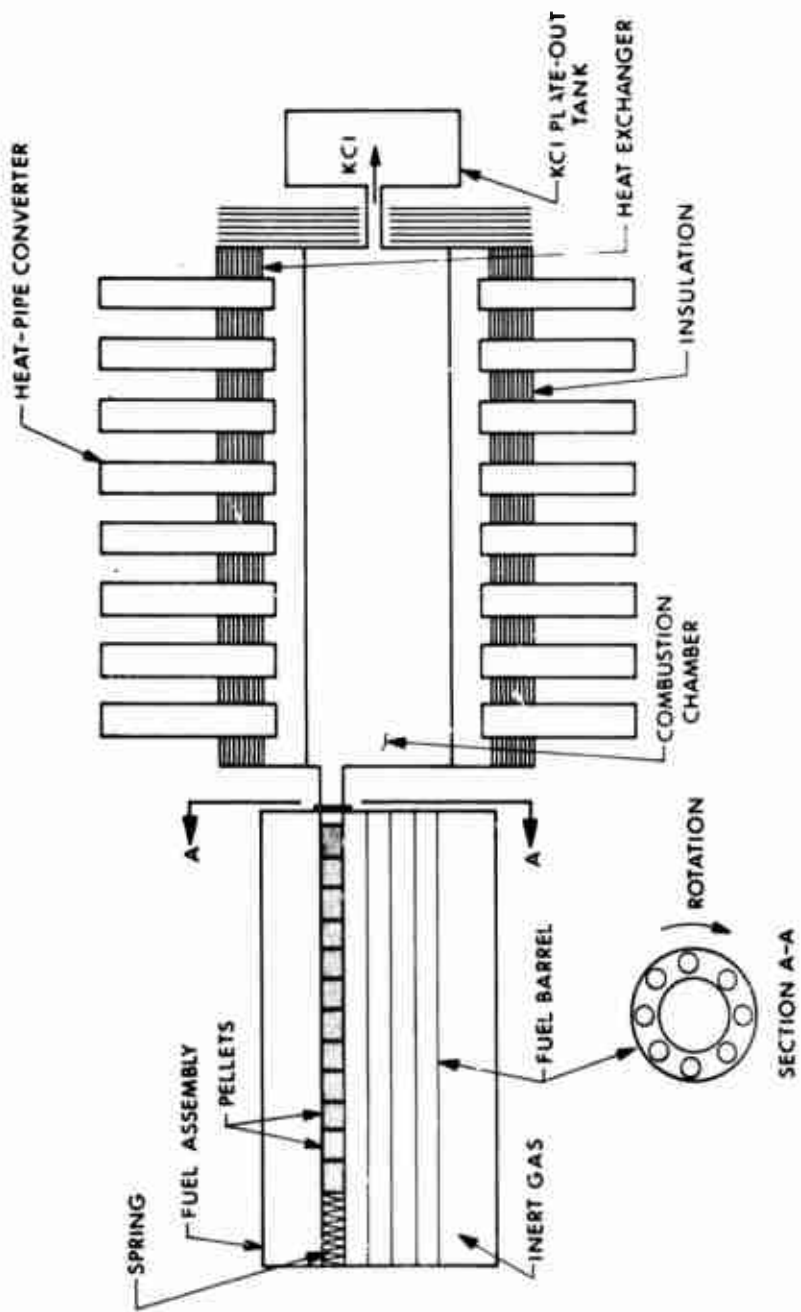

Figure 31. Generator Concept Using Pellet Feed System

### c. Generator Employing Slurry Feed System

Figure 32 shows the schematic arrangement of the slurry feed concept. Basically, the thermionic generator proper is the same for all three concepts considered. One of the slurry feed candidates is a mixture of liquid fluorocarbon, magnesium powder, and a trace of powdered Teflon. The storage tank will be a steel cylinder equipped with a sliding piston. It is connected to a sealed nitrogen tank pressurized to 150 psi. The fuel feed can be initiated by puncturing the seal, which allows the nitrogen gas to push the piston forward. The feed rate is controlled by a proper sizing of the injector orifice which must be cooled and kept below the autoignition temperature of  $610^{\circ}\text{C}$ . The pressure in the combustion chamber will be controlled by providing a plate-out tank for excess magnesium, which is the principal gaseous component.

Next to the solid bed reactor concept, the slurry feed approach is very attractive since it requires only a single, but reliable, moving part. However, additional work in two principal areas will be required. One is concerned with the rheology of slurry flow to insure that flow stoppage will not occur. The second area will be the thermal design of the injector to insure that ignition flashback will not be a problem.

### 3. PERFORMANCE ANALYSIS

In this section, the performance of the pyrochemical thermionic generator will be evaluated, based upon the fuel experimental data reported previously. Two performance parameters which are of interest to us are the specific energy and volume expressed in watt-hr/lb and watt-hr/in<sup>3</sup>. These quantities will be presented in parametric forms as a function of the operating lifetime.

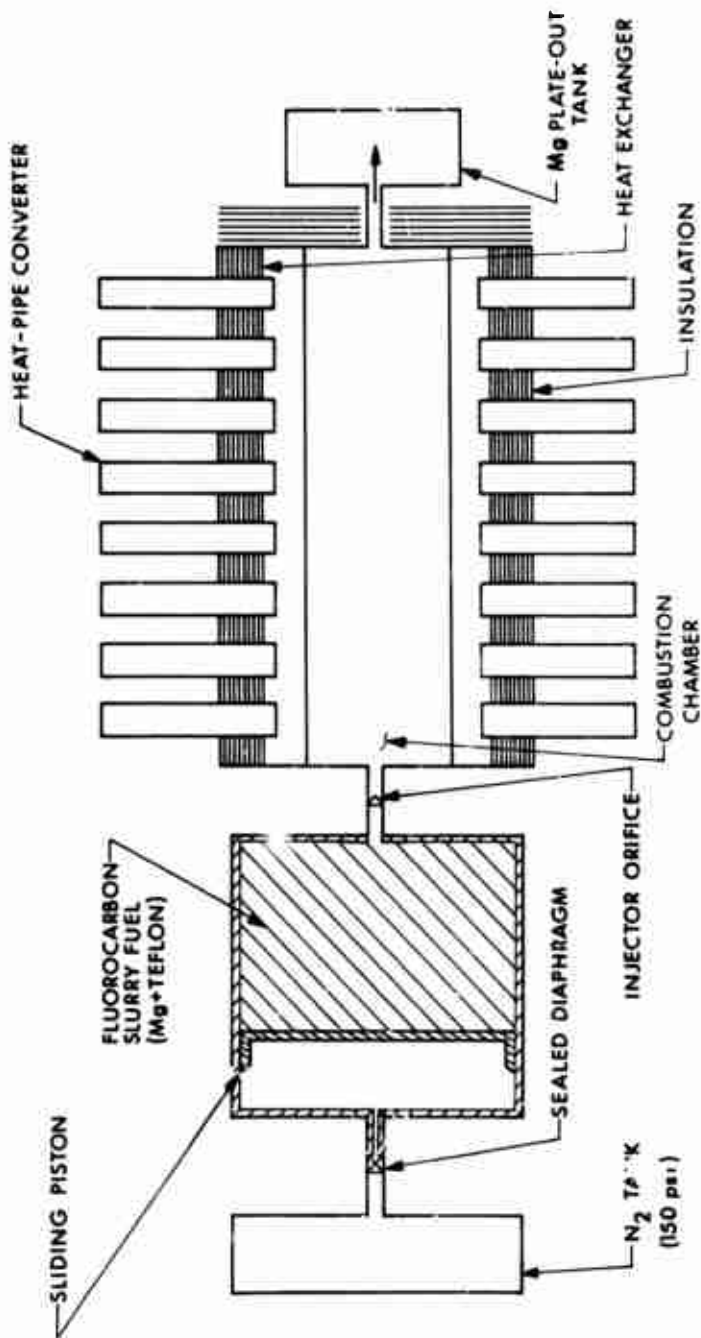

Figure 32. Generator with Slurry Fuel Feed

The baseline design will be based on the solid bed aluminum/potassium perchlorate fuel. Two types of thermionic converters will be considered: an intermediate advanced converter typified by a collector work function of 1.2 eV, and a potentially advanced converter typified by a 1.0 eV collector work function. We shall also analyze the performance of the system using other higher energy fuels.

#### a. Thermionic Converter

To achieve a lightweight compact thermionic power system, it is desirable to operate the thermionic converter at the highest temperature practicable. The resulting high conversion efficiency and power density associated with high-temperature operation offers a lightweight converter, a lightweight radiator, a minimum amount of required fuel, and, finally, a compact lightweight heat source.

A preliminary system analysis indicates that the system weight is near optimum (between performance and materials problems) when the emitter is approximately 1750°C. From the standpoint of thermionic converter operating experience, considering the seal technology (less than 1000°C), practical electrode spacing (3 to 5 mils), material compatibility, and voltage holdoff problem, the emitter temperature of 1750°C appears to be the best compromise. The projected operating characteristics of the 1.2 and 1.0 eV converters in the thermionic generator are summarized below:

#### OPERATING CHARACTERISTICS OF ADVANCED THERMIONIC CONVERTERS

	$\phi_c = 1.2 \text{ eV}$	$\phi_c = 1.0 \text{ eV}$
Emitter temperature, °C	1750	1750
Collector temperature, °C	850	750*
Power density, watts/cm <sup>2</sup>	50	65
Output voltage, volts	0.8	1.0
Conversion efficiency, percent	30	38
Electrode spacing, mils	3.0	3.0

\*(Lower temperature assumed for conservative radiator weight estimate and to alleviate collector surface stability problems.)

The converter will be constructed from a heat-pipe emitter and a heat-pipe collector. The use of heat pipes virtually eliminates the temperature variation on the emitter and collector surfaces. The power density and efficiency characteristics as a function of emitter operating temperature are shown in Figs. 33 and 34.

For a system operating at a 1750°C emitter temperature, the power densities for the 1.2 eV and 1.0 eV converters are 50 and 65 watts/cm<sup>2</sup>, respectively. Sixty-four converters are required. The total weights of the converters based on a 20-mil heat pipe wall are, respectively, 2.15 and 1.75 pounds.

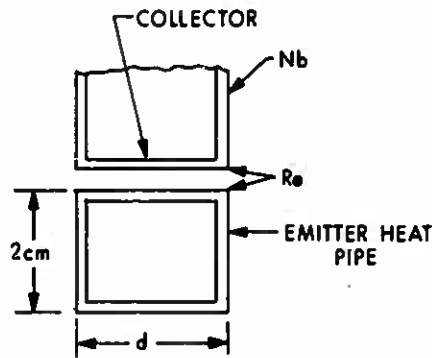

$$d = 2.00, \phi_c = 1.2$$

$$= 1.75, \phi_c = 1.0$$

b. Radiator

The total heat to be rejected from the radiator can be calculated from the equation

$$Q_r = P \left( \frac{1}{\eta_G} - 1 \right)$$

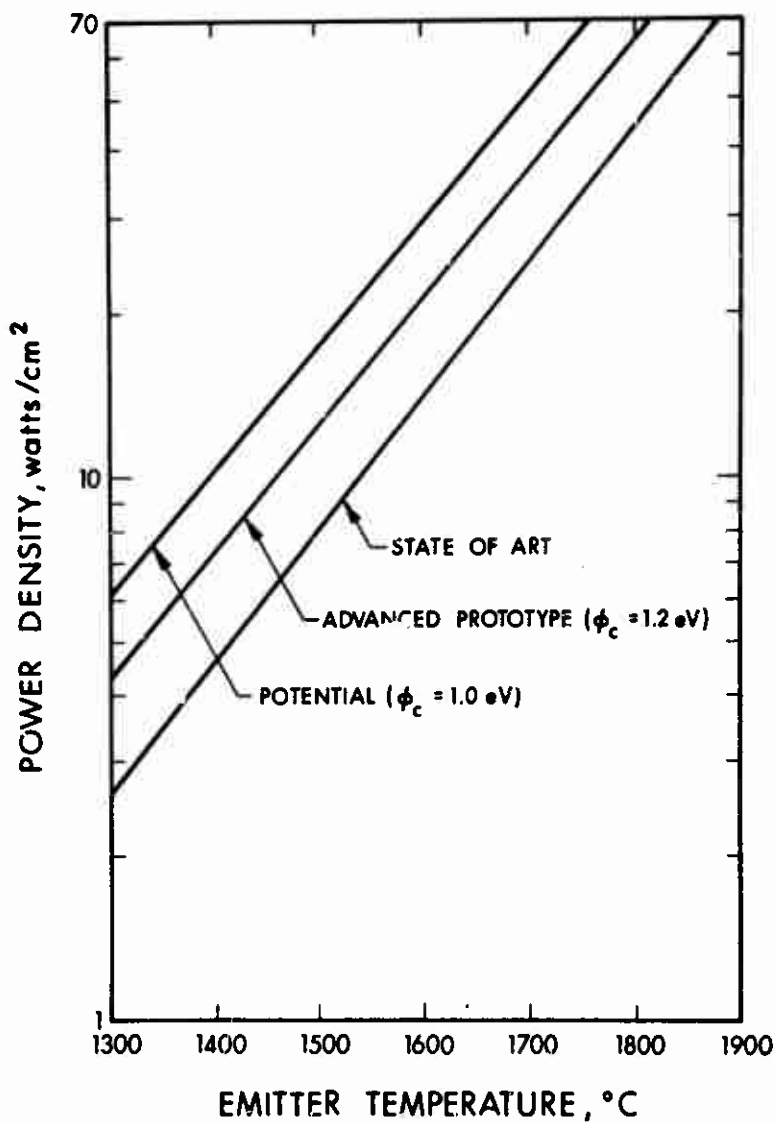

Figure 33. Thermionic Converter Power Density versus Emitter Temperature

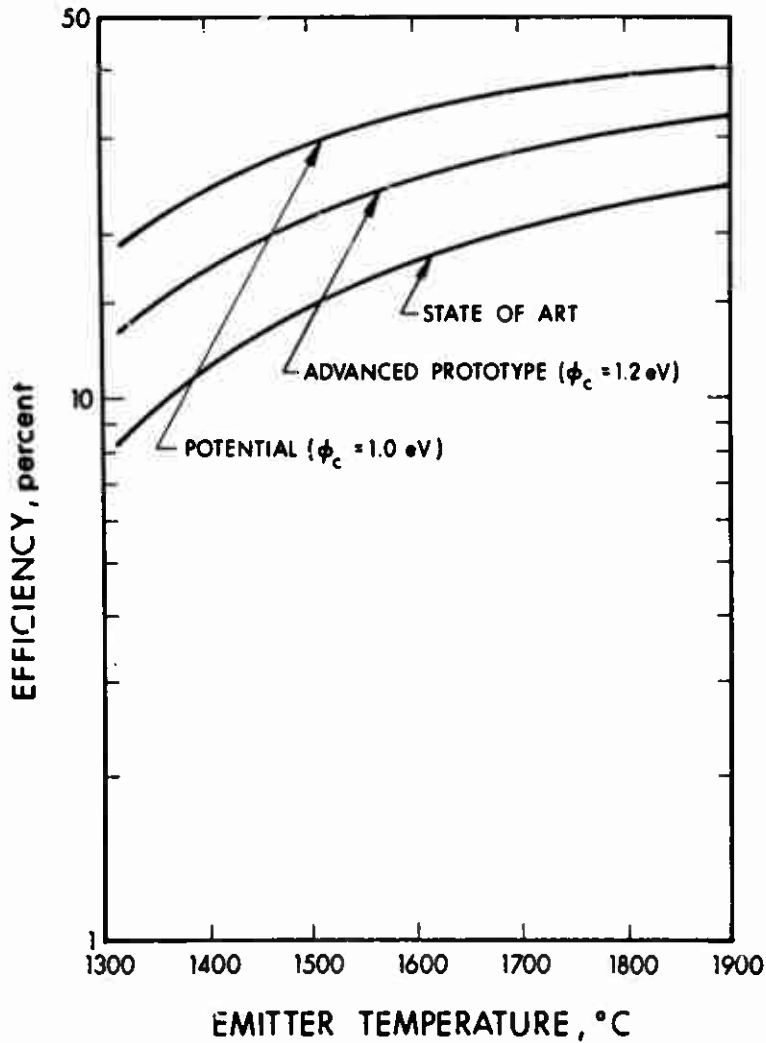

Figure 34. Thermionic Converter Efficiency versus Emitter Temperature

$$Q_r = P \left( \frac{1}{\eta_G} - 1 \right)$$

where  $Q_r$  = rejected heat  
 $P$  = electrical power output  
 $\eta_G$  = generator efficiency

The generator efficiencies, assumed to be 90 percent of the converter efficiencies, are 27 and 34 percent for the system utilizing the 1.2 and 1.0 eV converters.

The radiator area required is given by the equation

$$A_r = \frac{Q_r}{\epsilon \sigma T_c^4}$$

where  $A_r$  = radiator area  
 $\epsilon$  = emissivity  $\approx 0.9$   
 $\sigma$  =  $5.67 \times 10^{-12}$  watt/cm<sup>2</sup> °K<sup>4</sup>  
 $T_c$  = collector/radiator temperature, °K

The weight of the radiator was calculated by assuming an Nb heat-pipe wall of 20 mils. The radiator parameters are summarized below:

	$\phi_c = 1.2$ eV	$\phi_c = 1.0$ eV
Collector/radiator temperature, °C	850	750
Total heat rejected, watts	$2.7 \times 10^4$	$1.94 \times 10^4$
Radiator area, cm <sup>2</sup>	$3.33 \times 10^3$	$3.46 \times 10^3$
Radiator weight, lb	3.96	4.14

#### c. Heat Exchanger (Combustion Chamber)

The heat-pipe heat exchanger (Fig. 35) is essentially an annular structure. Refractory alloys such as Ta-10W, W-25Re, or Re-50Mo which

have superior strength at high temperatures are suitable for this application. The densities of these alloys are estimated to be 16.8, 19.7, and 15.6 g/cm<sup>3</sup>, respectively. For the purpose of weight estimates, W-25Re will be used since both tungsten and rhenium were found to be compatible with the reaction. The weight of the heat exchanger built from 20-mil W-25Re was calculated to be 4.0 lb. The KCl tank weight was 1 lb.

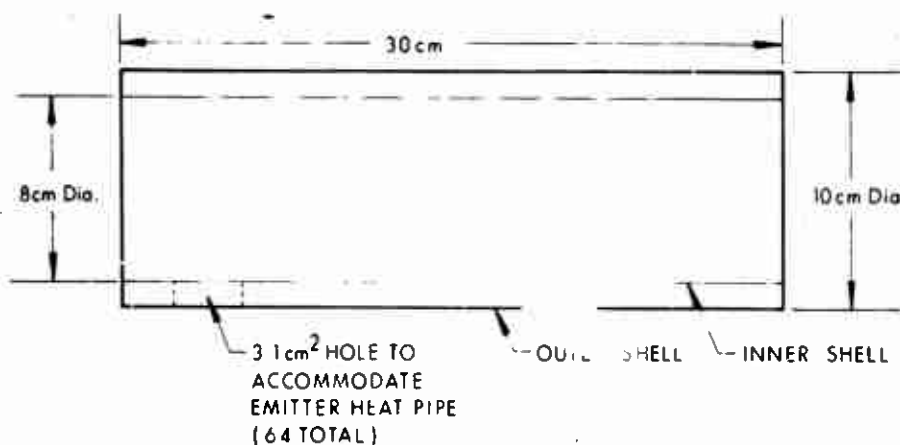

Figure 35. Heat Exchanger

#### d. Fuel Requirements

For the fuel containing 40% Al and 60% KClO<sub>4</sub>, the measured energy yield (at 25°C) is 2100 cal/g. The energy required to raise the reaction products to the combustion temperature of 2330°K was calculated to be 650 cal/g. The net energy output available for thermionic energy conversion will be 1450 cal/g. The thermal power required for the 1.2 eV converter is 37 kW. If the 1.0 eV converter is used, the power required will be 29.4 kW, indicating further improvement in

efficiency. The fuel weight shown below includes 50 grams of igniter which will also heat up the heat exchanger structure to the operating temperature of 2023°K.

Time (minutes)	Fuel Weight (lb)	
	$\phi_c = 1.2 \text{ eV}$	$\phi_c = 1.0 \text{ eV}$
1	0.9	0.8
10	8.2	6.6
20	16.4	13.0
30	24.6	19.5

#### e. Total System Weight

The total system weight and the weight breakdown for various components are listed in Tables XIX and XX for the generator using Al/KP fuel in combination with 1.2 and 1.0 eV converters. The weight estimates were calculated for various operating times up to 30 minutes.

#### f. Performance Characteristics

The specific energy characteristics of the generator using Al/KP fuel are summarized in Fig. 36. At 30-minute operating times, the specific energy varies from 127 to 150 watt-hr/lb.

The specific volume characteristics are shown in Fig. 37. The calculated volume was based on the outside envelope. Although a further packaging optimization is possible, the information given will be sufficiently accurate for integration planning purposes. In the operating time range of 10 to 30 minutes, the generator volume varies from 0.09 to 0.12 ft<sup>3</sup>/kW.

TABLE XIX

SYSTEM WEIGHT FOR Al/KP FUEL ( $\phi_c = 1.0$  eV)

<u>Component Weight (lb)</u>	<u>Operating Time (minutes)</u>			
	<u>1</u>	<u>10</u>	<u>20</u>	<u>30</u>
Converter	1.80	1.80	1.80	1.80
Radiator	4.1	4.1	4.1	4.1
Fuel and Igniter	0.8	6.6	13.0	19.5
Combustion Chamber/Heat Exchanger	<u>5.0</u>	<u>5.0</u>	<u>5.0</u>	<u>5.0</u>
Subtotal	11.7	17.5	23.9	30.4
Miscellaneous	<u>1.2</u>	<u>1.8</u>	<u>2.4</u>	<u>3.0</u>
Total Generator	12.9	19.3	26.3	33.4
Watt-hr	167	1670	3340	5010
Watt-hr/lb	13	87	127	150

TABLE XX

SYSTEM WEIGHT FOR Al/KP FUEL ( $\phi_c = 1.2$  eV)

<u>Component Weight (lb)</u>	<u>Operating Time (minutes)</u>			
	<u>1</u>	<u>10</u>	<u>20</u>	<u>30</u>
Converter	2.2	2.2	2.2	2.2
Radiator	4.0	4.0	4.0	4.0
Fuel & Igniter	0.9	8.2	16.4	24.6
Combustion Chamber/Heat Exchanger	<u>5.0</u>	<u>5.0</u>	<u>5.0</u>	<u>5.0</u>
Subtotal	12.1	19.4	27.6	35.8
Miscellaneous	<u>1.2</u>	<u>1.9</u>	<u>2.8</u>	<u>3.6</u>
Total Generator	13.3	21.3	30.4	39.4
Watt-hr	167	1670	3340	5010
Watt-hr/lb	13	78	110	127

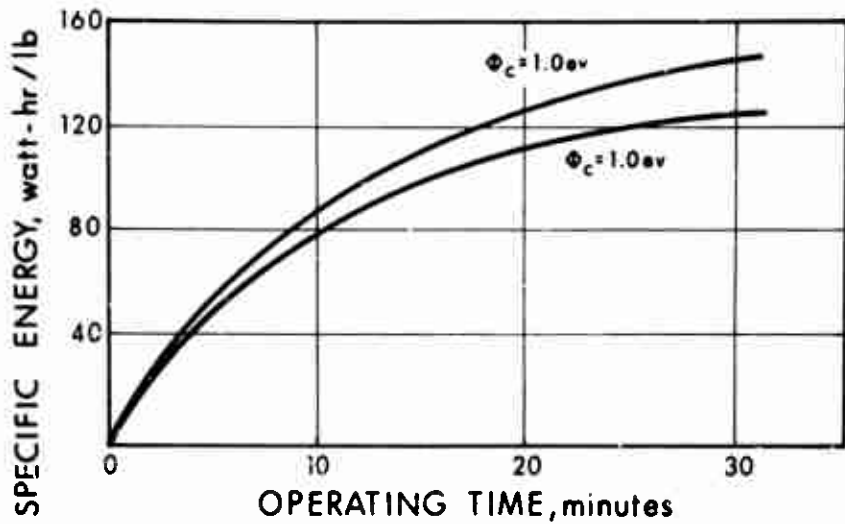

Figure 36. Specific Energy Characteristics of Al/KClO<sub>4</sub> Fueled Generator

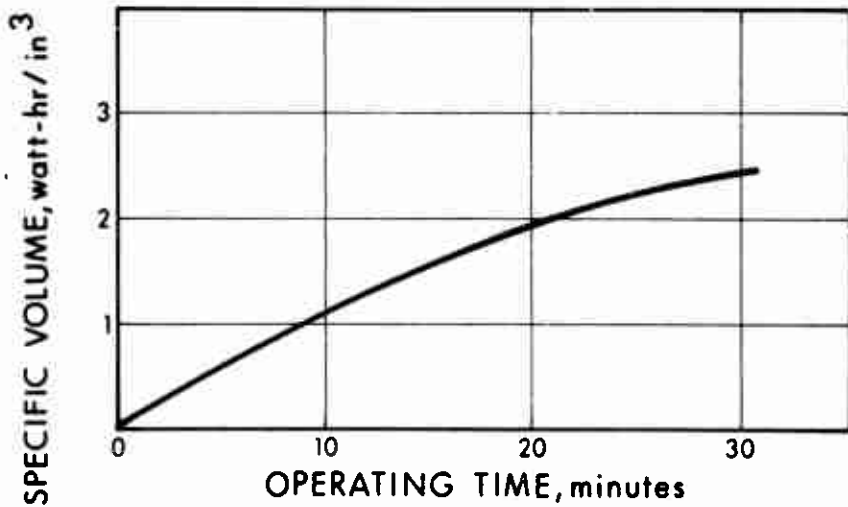

Figure 37. Specific Volume Characteristics of Al/KClO<sub>4</sub> Fueled Generator

g. Performance Characteristics with High Energy Fuels

The performance parameters presented thus far have been based on aluminum/potassium perchlorate fuel. The performance level is typical of all three fuels investigated in this contract, namely, the Al/KP, Mg/KP, and Mg/Teflon. These fuels have common characteristics in that they are premixed (i.e., the metal powder and its oxidizer are a homogeneous mixture prior to combustion) and they are storable with long shelf lives.

We shall now estimate the performance potential of the pyrochemical thermionic generator concept utilizing a different class of fuels which are more energetic. A parametric analysis was performed for four types of fuels. Their watt-hr/lb performances based on 1750°C emitter temperature are summarized in Table XXI for a 30-minute operation. The performance characteristics as a function of fuel energy yield for various operating times are shown in Fig. 38

TABLE XXI  
PERFORMANCE CHARACTERISTICS OF HIGH ENERGY FUELS

<u>Fuel</u>	<u>Theoretical Yield (cal/g)</u>	<u>Watt-hr/lb</u>
Mg + N <sub>2</sub> O <sub>4</sub>	3000	190
Mg + O <sub>2</sub>	3500	215
Be + N <sub>2</sub> O <sub>4</sub>	4440	270
Be + O <sub>2</sub>	5750	325

The four high energy fuels considered belong to the same class; i.e., they are not premixed. The metal powder and oxidizer, which are stored separately, are injected into the combustion chamber simultaneously. If two nozzles are employed, the flashback problem will be

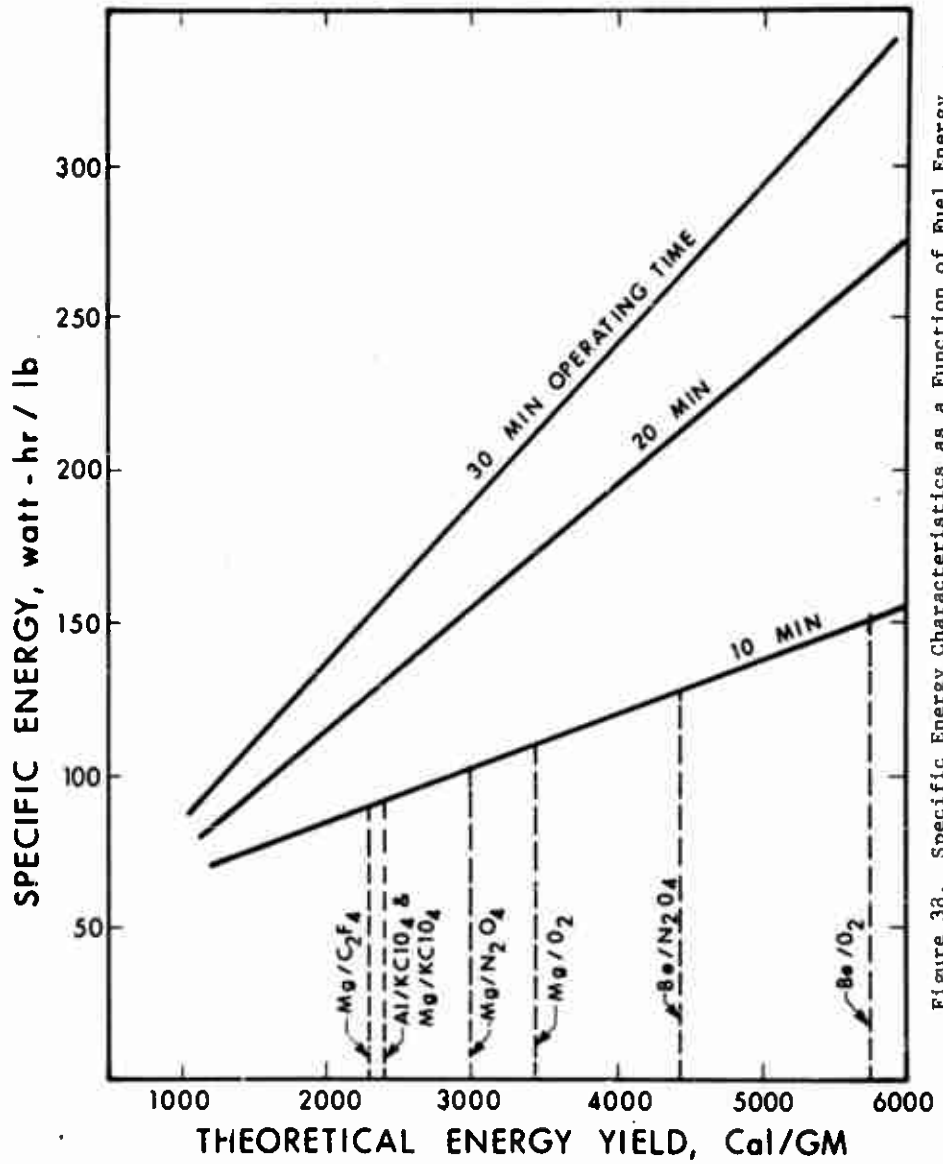

Figure 38. Specific Energy Characteristics as a Function of Fuel Energy

eliminated. For the  $Mg/N_2O_4$  and  $Be/N_2O_4$  systems, the fuels will still be storable with long shelf lives; however, their reaction products are gaseous. Their use will therefore have to be in the application where gas exhaust is permissible. On the other hand, the  $Mg/O_2$  and  $Be/O_2$  systems offer the possibility of no exhaust gas, since the reaction products will be solid particles. Their primary drawback is the use of cryogenic oxygen. In our opinion, this is most objectionable since the generator will not be in the state of "instantaneous readiness." However, there may be applications where a slight delay in oxidizer loading can be tolerated. If this is the case, the systems employing liquid oxygen will be attractive.

As a general rule, the magnesium fuels ignite and sustain combustion easily. Based on our previous results, the flame temperature will be moderately high but suitable for thermionic conversion in the  $1700^{\circ}$  to  $1800^{\circ}C$  range. Beryllium fuels, on the other hand, are more difficult to ignite and burn at a higher temperature. This could create a material problem. Because of the higher temperature we anticipate, however, that the performance characteristics will be even higher than those presented.

SECTION V  
RECOMMENDATIONS

The experimental and analytical results, which were reported in Sections II through IV, have clearly demonstrated the feasibility of the pyrochemical thermionic generator. Specifically, it was shown that moderately high energy fuels, such as Al/KClO<sub>4</sub>, Mg/KClO<sub>4</sub>, and Mg/Teflon, can be ignited and burned without difficulty, and the resulting combustion temperature and heat flux are entirely compatible with efficient thermionic conversion at approximately 1750°C. Materials which can contain the reaction have also been identified experimentally. A generator utilizing a moderately energetic fuel, such as Al/KClO<sub>4</sub>, will result in a lightweight power supply which has a specific energy in the range of 130 to 150 watt-hr/lb for a 30-minute operating time. In addition, the same generator concept will have an ultimate potential of 325 watt-hr/lb performance if higher energy fuels are used. This ultimate performance exceeds that of any known spaceborne primary battery concept by more than a factor of two.

Because of its high performance potential, we strongly recommend that the pyrochemical thermionic generator be developed. We believe the recommended development program is realistic and that a concerted effort will result in an operational system of the 150 watt-hr/lb class in about 3 years. For the 300 watt-hr/lb class, 2 additional years of development will be required. However, if the need arises, an accelerated program can be implemented by development of several tasks which can be attacked on a parallel basis.

Basically, the recommended development plan is based on the following premises:

- A 150 watt-hr/lb generator will be the primary objective.
- This will be augmented by a parallel research effort on higher energy fuels leading to feasibility of the higher performance system.
- At the end of 3 years, the 150 watt-hr/lb working model generator will be operational. The Air Force will have an option at that time whether to pursue the flight qualification program or to continue the development of the higher performance system.

#### 1. PHASE II PROGRAM

The suggested follow-on program is based on the logical extension of the Phase I work (existing contract). In addition, it is based on complementary technology resulting from an in-house program concerned with heat pipes and thermionic converters. The following paragraphs give a brief description of the suggested Phase II effort. The estimated performance duration is 18 months.

##### Task 1. Heat Source Development (12 months)

A solid bed fuel will be developed. Initially, the effort will be concentrated on combustion experiments designed to provide burning rate data at variable combustion pressures of Al/KClO<sub>4</sub>. Various fuel casings and different means of fabrication will be investigated. We shall also explore the means of controlling the combustion pressure by the use of the KCl plate out tank. The end objective will be to develop a long solid bed fuel which will burn at the rate specified by the mission lifetime.

Task 2. Double-Wall Heat Pipe Combustion Chamber (8 months)

A double-wall heat pipe is a critical component used to remove the combustion energy and deliver it to the thermionic converters. As envisioned for the pyrochemical thermionic generator, the double-wall heat pipe and combustion chamber will be fabricated as an integral unit, with heat pipe converters (to be described next) embedded between the walls. The converter outer surface, electrically insulated, will serve as a capillary structure for the fluid return path.

Initially, such a complex structure as described previously will not be attempted. We will first design and fabricate a concentric double-wall structure suitable for operation at 1700 to 1800°C. Our objective will be to evaluate two types of capillary structures (wick and grooved channels or a combination), and to demonstrate that heat can be supplied to the internal member and removed at the outer surface of the external wall. This will be followed by a prototype with mock-ups of converters which will simulate the thermal requirements of the converters.

Task 3. Heat-Pipe Converter (8 months)

For this converter, both the emitter and collector/radiator structures will be made from heat pipes. The advantageous features will be: extremely light weight and extremely uniform temperatures at the energy conversion surfaces. The converter will be a planar type, as shown. Our plan is to first fabricate two heat pipes, one to be operated at 1700°C (emitter) and the other at 800°C (collector). After a thermal check to verify the heat transfer capability, rhenium will be deposited on the energy conversion surface. The metal-ceramic seal will be similar to the EOS standard prefabricated seal developed in the other programs.

Significantly, EOS, under internal funding, is currently developing three types of heat pipes: one in the 1700 to 1800°C range, one in the 1300 to 1500°C range, and the other in the 600 to 900°C range. The 1700°C heat pipe has been operated successfully and we anticipate that the other devices will be ready for operational testing shortly. The technology developed will be very complementary to the efforts proposed in Tasks 2 and 3.

Task 4. Test of Feasibility Model (12 months)

The effort for this task will be to design and fabricate the feasibility model of the reactor which is coupled with thermionic converters. The feasibility model will not be a full-scale generator, but will consist of a combustion chamber, two or three converters, and a solid bed fuel system. The objective will be to demonstrate the chemical/electrical energy conversion feasibility.

Task 5. High Thermal Conductance Electrical Insulator Study (6 months)

Very few electrical insulators maintain their insulating characteristics when subjected to high temperature for a long duration. Fortunately, the anticipated application is short-term so that different materials which would not normally be used will be applicable. Various ceramic oxides and nitrides should be evaluated, both analytically and experimentally.

Task 6. Hardware Design of Integrated Working Model (12 months)

Analytical and experimental results obtained from the tasks described will be utilized in the hardware design of an integrated working model. The design philosophy will be that each major component can be fabricated and tested prior to a final integration step. For example, the

heat pipe converter, double-wall combustion chamber, and solid bed fuel system can be constructed and tested separately prior to the final fabrication step. With this methodology, the weakness in any major component can be corrected before the design is too far committed to affect the other components.

Task 7. Research on High Energy Fuel (18 months)

A parallel research program on highly energetic fuel is recommended. The objective is to conduct an exploratory investigation toward developing a heat source capable of doubling the power output in the range of 200 to 300 watt-hr/lb.

2. PHASE III PROGRAM

Following the successful completion of the 18-month Phase II program, work should be initiated with the objective of achieving an operational working model in 18 months. The major tasks for this phase may be the following:

- Fabrication of major components
- Individual testing of each major component
- Integration of working model
- Test of working model
- Continued research in higher energy fuels
- Formulation of plans for a flight qualification program

## REFERENCES

1. A. A. Shidlovsky, Fundamentals of Pyrotechnics, Technical Memorandum 1615, Feltman Research Laboratories, Picatinny Arsenal (May, 1955), translated by U. S. Joint Publication Research Service from a Russian Textbook, Osnovy Pirotechnik (1964).
2. JANAF Thermochemical Tables, D. R. Stull, Project Director, Dow Chemical Company (August, 1966).
3. O. A. Hougen and K. M. Watson, Chemical Process Principles, Vol. 1, John Wiley & Sons, Inc., New York (1952), p. 253.
4. Colin J. Smithells, Metals Reference Book, Vol. II, Butterworths Scientific Publications (1955).
5. Handbook of Chemistry and Physics, 45th Edition, The Chemical Rubber Co., Cleveland, Ohio (1964).
6. F. Ullmann, Enzyklopaedie der Technisches Chemie, 3rd Ed., W. t-oerst, Muenchen (1951).
7. J. W. Mellor, A Comprehensive Treatise of Inorganic and Theoretical Chemistry, Longmans Green & Co., Ltd., London (1927), New Impression 1952.
8. G. J. B. Fisher, Incendiary Warfare, McCraw-Hill Book Co., Inc., New York (1946).
9. Herbert Ellern, Modern Pyrotechnics, Chemical Publishing Co., Inc., New York (1961).
10. Perchlorates, ACS Monograph 196, ed. by J. C. Schumacher, Reinhold Publishing Co., New York (1960).
11. Chlorates and Perchlorates, Their Manufacture, Properties and Uses, NAVORD Report 7147, Southwest Research Institute (May, 1960).
12. O. Kubaschewski and E. L. Evans, Metallurgical Thermochemistry, John Wiley & Sons, New York (1956).
13. E. C. Miller, A. E. Blake, R. M. Schirmer, C. D. Killredge, and E. H. Fromm, Radiation from Laboratory Scale Jet Combustor Flames, Phillips Petroleum Co., Research Report 1526-56R on U. S. Navy Contract 52-132-C (1965).
14. A. C. Stancliffe and M. G. Coombs, "Compact Turbo Alternator Power Systems for Re-entry Vehicle Applications," Advances in Energy Conversion Engineering, 1967 Inter. Soc. Energy Conversion Engineering Conf., Miami, Florida.
15. E. H. Hietbrink, J. J. Petraitis, and C. M. Craig, "Short Duration Lithium-Chloride Primary Battery Systems," Advances in Energy Conversion Engineering, 1967 Inter. Soc. Energy Conversion Engineering Conf., Miami, Florida.

UNCLASSIFIED

Security Classification

## DOCUMENT CONTROL DATA - R &amp; E

(Security classification of title, body of abstract and indexing annotation must be entered when the overall report is classified)

1. ORIGINATING ACTIVITY (Corporate author) Electro-Optical Systems, Inc., A Xerox Company 300 N. Walstead Street Pasadena, California 91107		2a. REPORT SECURITY CLASSIFICATION Unclassified	
2. REPORT TITLE  PYROCHEMICAL THERMIONIC HEAT SOURCE INVESTIGATION			
4. DESCRIPTIVE NOTES (Type of report and inclusive dates) Final Report March 1967 - January 1968			
3. AUTHOR(S) (First name, middle initial, last name)  Phijit Jalichandra, et al.			
3. REPORT DATE May 1966		7a. TOTAL NO. OF PAGES 118	7b. NO. OF REFS 15
6a. CONTRACT OR GRANT NO. F33615-67-C-1545		6b. ORIGINATOR'S REPORT NUMBER(S) 7214-Final	
8. PROJECT NO.  Task 314520-007		9b. OTHER REPORT NO(S) (Any other numbers that may be assigned this report) AFAPL-TR-68-43	
10. DISTRIBUTION STATEMENT This document is subject to special controls and each transmittal to foreign governments or foreign nationals may be made only with prior approval of AFAPL.			
11. SUPPLEMENTARY NOTES		12. SPONSORING MILITARY ACTIVITY Air Force Aero Propulsion Laboratory Wright-Patterson Air Force Base, Ohio	
13. ABSTRACT  This report describes a feasibility study of a chemically fueled thermionic generator and includes a study of pyrochemical fuels for this generator. The program consisted of three tasks: heat source study, materials compatibility study, and system conceptual design. System performance goals were that the generator should have a capability of from 1 to 100 kW with a minimum specific energy of 100 W-hr/lb for up to 30 minutes. Fuel preparation and processing are specified and the characteristics of three fuel combinations (Al/KClO <sub>4</sub> , Mg/KClO <sub>4</sub> , and Mg/Teflon) were measured. A solid bed fuel or a slurry fuel system is recommended. Vapor-deposited rhenium was chosen as the combustion chamber material. It was concluded that a pyrochemical thermionic generator using solid fuels (e.g., Al/KClO <sub>4</sub> ) is feasible and offers a lightweight power supply with a specific energy of 130 to 150 W-hr/lb for a 30-minute operation with a growth potential in excess of 300 W-hr/lb. This generator concept is believed to be superior to other power supply concepts and a recommended plan for the development of such a generator is outlined in this report.			

DD FORM 1473  
NOV 65UNCLASSIFIED  
Security Classification

14. KEY WORDS	LINK A		LINK B		LINK C	
	ROLE	WT	ROLE	WT	ROLE	WT
Thermionic generator						
Pyrochemical fuels						
Heat source						
Power supply						
Combustion chamber materials						
Heat transfer						
Design						