

UNCLASSIFIED

AD NUMBER: AD0833051

LIMITATION CHANGES

TO:

Approved for public release; distribution is unlimited.

FROM:

Distribution authorized to U.S. Defense agencies;
Administrative/Operational Use; 1 Jul 1968. Other requests shall be
referred to the Army Chief of Engineers, Military Construction,
WashInston, D. C. 20315

AUTHORITY

OCE, D/A LTR, 13 Sep 1976

AD833051
FILE COPY

AD

OCE NEMP PROGRAM
Development of Criteria
for
Protection of NIKE-X Power Plant and Facilities
Electrical Systems Against
Nuclear Electromagnetic Pulse Effects
MAGNETICALLY INDUCED VOLTAGES ON
CONDUCTORS WITHIN COVERED CABLE TRAYS

1 July 1968

Submitted by:
E. R. UHLIG

Placed by:
Military Construction
Office of the Chief of Engineers
Department of the Army
Washington, D. C. 20315

DDC
RECEIVED
JUN 6 1968
RECEIVED

C
Vb

The findings in this report are not to be construed as an official Department of the Army position unless so designated by other authorized documents.

CONTRACT NUMBER DA - 49 - 129 - ENG - 543

GENERAL ELECTRIC COMPANY
PITTSFIELD, MASS.

Each transmittal of this document outside the Department of Defense must have prior approval of Military Construction, Office of the Chief of Engineers, Department of the Army, Washington, D. C. 20315.

Unclassified
Security Classification

DOCUMENT CONTROL DATA - R&D		
<i>(Security classification of title, body of abstract and indexing annotation must be entered when the overall report is classified)</i>		
1. ORIGINATING ACTIVITY (Corporate author) General Electric Company 100 Woodlawn Avenue Pittsfield, Massachusetts 01201		20. REPORT SECURITY CLASSIFICATION Unclassified
		20. GROUP
3. REPORT TITLE OCE NEMP PROGRAM, Development of Criteria for Protection of NIKE-X Power Plant and Facilities Electrical Systems Against Nuclear Electromagnetic Pulse Effects, MAGNETICALLY INDUCED VOLTAGES ON COND. WITHIN COVERED CABLE TRAYS		
4. DESCRIPTIVE NOTES (Type of report and inclusive dates) Final Report - 1 February 1968 to 1 May 1968		
5. AUTHOR(S) (Last name, first name, initial) Brustle, H. H.		
6. REPORT DATE 1 July 1968	70. TOTAL NO. OF PAGES 24	70. NO. OF REFS 2
80. CONTRACT OR GRANT NO. DA-49-129-ENG-543 a. PROJECT NO.	90. ORIGINATOR'S REPORT NUMBER(S) 68U01	
c. d.	90. OTHER REPORT NO(S) (Any other numbers that may be assigned this report) None	
10. AVAILABILITY/LIMITATION NOTICES Each transmittal of this document outside the Department of Defense must have prior approval of Military Construction, Office of the Chief of Engineers, Department of the Army, Washington, D. C. 20315		
11. SUPPLEMENTARY NOTES None	12. SPONSORING MILITARY ACTIVITY Military Construction, OCE Department of the Army Washington, D. C. 20315	
13. ABSTRACT This document describes a series of tests to determine the magnetically induced voltages on conductors within solid metal and expanded metal cable trays. The work is an extension of that reported in #67U10 relating to other types of electrical raceways.		

DD FORM 1473
1 JAN 64

Unclassified
Security Classification

14. KEY WORDS	LINK A		LINK B		LINK C	
	ROLE	WT	ROLE	WT	ROLE	WT
NEMP Effects Shielding Power System Protection						

INSTRUCTIONS

1. ORIGINATING ACTIVITY: Enter the name and address of the contractor, subcontractor, grantee, Department of Defense activity or other organization (corporate author) issuing the report.

2a. REPORT SECURITY CLASSIFICATION: Enter the overall security classification of the report. Indicate whether "Restricted Data" is included. Marking is to be in accordance with appropriate security regulations.

2b. GROUP: Automatic downgrading is specified in DoD Directive 5200.10 and Armed Forces Industrial Manual. Enter the group number. Also, when applicable, show that optional markings have been used for Group 3 and Group 4 as authorized.

3. REPORT TITLE: Enter the complete report title in all capital letters. Titles in all cases should be unclassified. If a meaningful title cannot be selected without classification, show title classification in all capitals in parentheses immediately following the title.

4. DESCRIPTIVE NOTES: If appropriate, enter the type of report, e.g., interim, progress, summary, annual, or final. Give the inclusive dates when a specific reporting period is covered.

5. AUTHOR(S): Enter the name(s) of author(s) as shown on or in the report. Enter last name, first name, middle initial. If military, show rank and branch of service. The name of the principal author is an absolute minimum requirement.

6. REPORT DATE: Enter the date of the report as day, month, year, or month, year. If more than one date appears on the report, use date of publication.

7a. TOTAL NUMBER OF PAGES: The total page count should follow normal pagination procedures, i.e., enter the number of pages containing information.

7b. NUMBER OF REFERENCES: Enter the total number of references cited in the report.

8a. CONTRACT OR GRANT NUMBER: If appropriate, enter the applicable number of the contract or grant under which the report was written.

8b, 8c, & 8d. PROJECT NUMBER: Enter the appropriate military department identification, such as project number, subproject number, system numbers, task number, etc.

9a. ORIGINATOR'S REPORT NUMBER(S): Enter the official report number by which the document will be identified and controlled by the originating activity. This number must be unique to this report.

9b. OTHER REPORT NUMBER(S): If the report has been assigned any other report numbers (either by the originator or by the sponsor), also enter this number(s).

10. AVAILABILITY/LIMITATION NOTICES: Enter any limitations on further dissemination of the report, other than those imposed by security classification, using standard statements such as:

- (1) "Qualified requesters may obtain copies of this report from DDC."
- (2) "Foreign announcement and dissemination of this report by DDC is not authorized."
- (3) "U. S. Government agencies may obtain copies of this report directly from DDC. Other qualified DDC users shall request through _____."
- (4) "U. S. military agencies may obtain copies of this report directly from DDC. Other qualified users shall request through _____."
- (5) "All distribution of this report is controlled. Qualified DDC users shall request through _____."

If the report has been furnished to the Office of Technical Services, Department of Commerce, for sale to the public, indicate this fact and enter the price, if known.

11. SUPPLEMENTARY NOTES: Use for additional explanatory notes.

12. SPONSORING MILITARY ACTIVITY: Enter the name of the departmental project office or laboratory sponsoring (paying for) the research and development. Include address.

13. ABSTRACT: Enter an abstract giving a brief and factual summary of the document indicative of the report, even though it may also appear elsewhere in the body of the technical report. If additional space is required, a continuation sheet shall be attached.

It is highly desirable that the abstract of classified reports be unclassified. Each paragraph of the abstract shall end with an indication of the military security classification of the information in the paragraph, represented as (TS), (S), (C), or (U).

There is no limitation on the length of the abstract. However, the suggested length is from 150 to 225 words.

14. KEY WORDS: Key words are technically meaningful terms or short phrases that characterize a report and may be used as index entries for cataloging the report. Key words must be selected so that no security classification is required. Identifiers, such as equipment model designation, trade name, military project code name, geographic location, may be used as key words but will be followed by an indication of technical content. The assignment of links, roles, and weights is optional.

6
**OCE NEMP PROGRAM,
Development Criteria
for
Protection of NIKE-X Power Plant and Facilities
Electrical Systems Against
Nuclear Electromagnetic Pulse Effects.
MAGNETICALLY INDUCED VOLTAGES ON
CONDUCTORS WITHIN COVERED CABLE TRAYS.**

9 Final rept. 1 Feb - 1 May 68,

11 1 Jul 68

12 24 p.

~~Report by~~

10 H. H. BRUSTLE

Placed by:

**Military Construction
Office of the Chief of Engineers
Department of the Army
Washington, D. C. 20315**

The findings in this report are not to be construed as an official Department of the Army position unless so designated by other authorized documents.

15
CONTRACT NUMBER DA-49-129-ENG-543

**GENERAL ELECTRIC COMPANY
PITTSFIELD, MASS.**

Each transmittal of this document outside the Department of Defense must have prior approval of Military Construction, Office of the Chief of Engineers, Department of the Army, Washington, D. C. 20315.

(149 150)

1473
esf

TABLE OF CONTENTS

	<u>Page</u>
1.0 Introduction	1
2.0 Test Area and Setup	1
3.0 Induced Voltage Measuring System	5
4.0 Injected Current Tests and Applied Current Wave	5
5.0 Review of Related Past Work	7
6.0 Husky RFI Solid Metal Cable Tray	8
7.0 Cope Expanded Metal Cable Tray with Cover	10
7.1 Expanded Metal Cable Tray - Shielded Twisted Pair	12
7.2 Expanded Metal Cable Tray - Parallel Pair Wires	12
8.0 H-Field Tests	13
9.0 Comparison of Shielding Effectiveness of Various Raceways	15
10.0 Summary	19

1.0 INTRODUCTION

The OCE program to develop protective measures for protection of the SENTINEL power system against NEMP has entailed a diverse testing program in support of the design criteria effort. One phase of the testing effort involved the evaluation of the shielding effectiveness of various metal raceways. The work reported herein is a continuation of these efforts under Contract No. DA-49-129-ENG-543, Schedule D.

Specifically, this report describes the test methods used and presents the data obtained during an investigation which had as its objective the determination of the induced voltages on conductors in two types of cable trays. The data is compared to other type raceways which have been evaluated by similar test methods and previously reported¹.

2.0 TEST AREA AND SETUP

The test setup for the injected current tests is shown in Figure 1. The H-field tests are described later in this report. The test area was a shielded room measuring 45 feet x 35 feet x 20 feet high. The test specimen consisted of 24 feet of cable tray with cover. Both expanded metal tray and solid metal tray were tested. Both trays were assembled in accordance with the manufacturers suggested assembly practices. Details of both cable trays are shown in Figure 2. Photographs of the cable trays in place in the test area are shown in Figure 3. A metal, shielded connection box was attached to the tray at the measuring end to allow varying conductor connections. At the current pulse generator end, connection to the tray was made through conductors connected to all four sides of the tray to help equalize the current distribution at this point.

For test purposes a three-conductor, twisted pair cable was randomly placed in the cable tray, as well as several parallel pair conductors. All conductors were connected to the tray at the generator end while induced voltage measurements were made between pairs of conductors and from conductor to ground at the measuring end of the tray.

Aluminum Shielded Room (45' x 35' x 20' high)

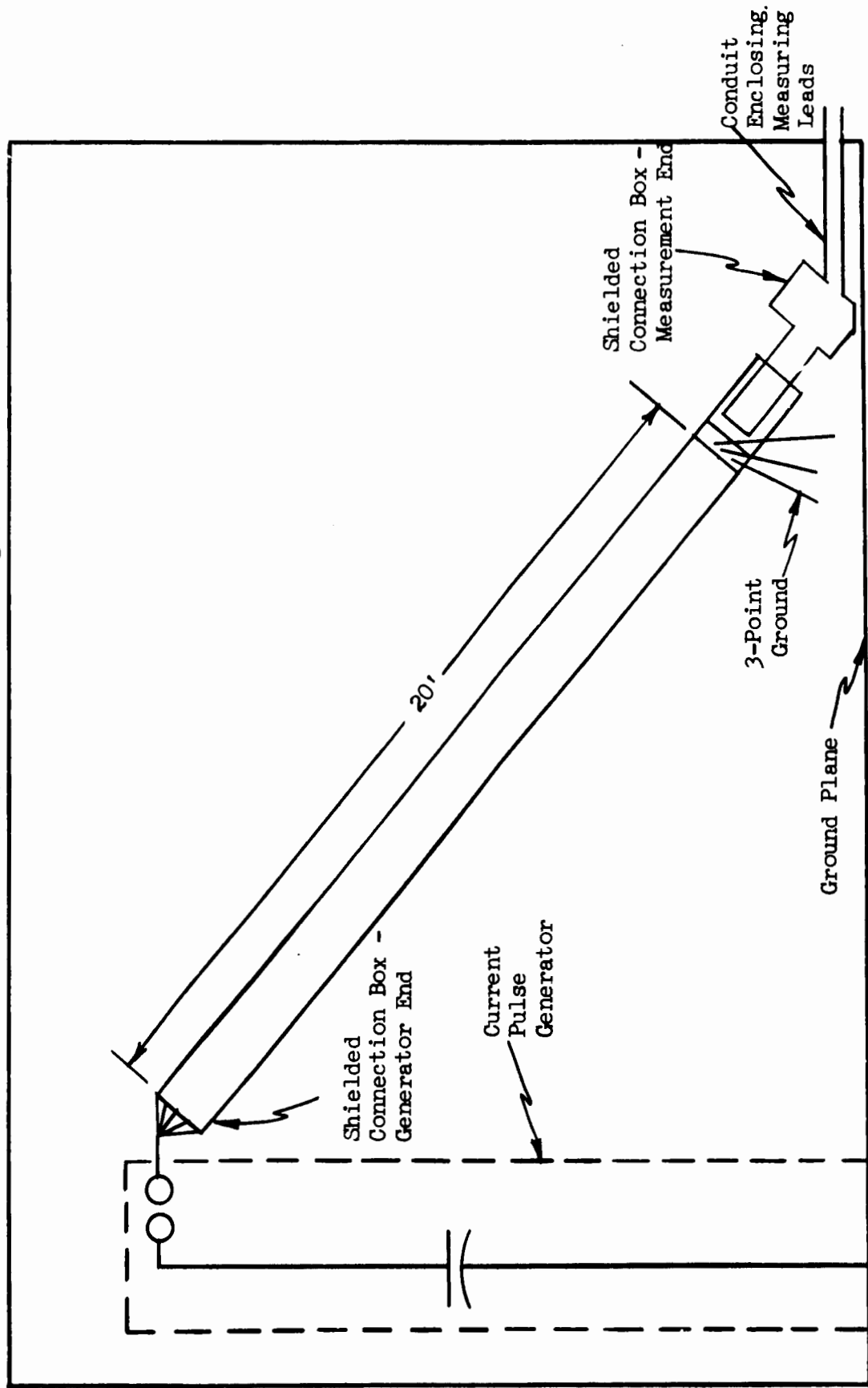

FIGURE 1 Test Area Setup for Injected Current Tests

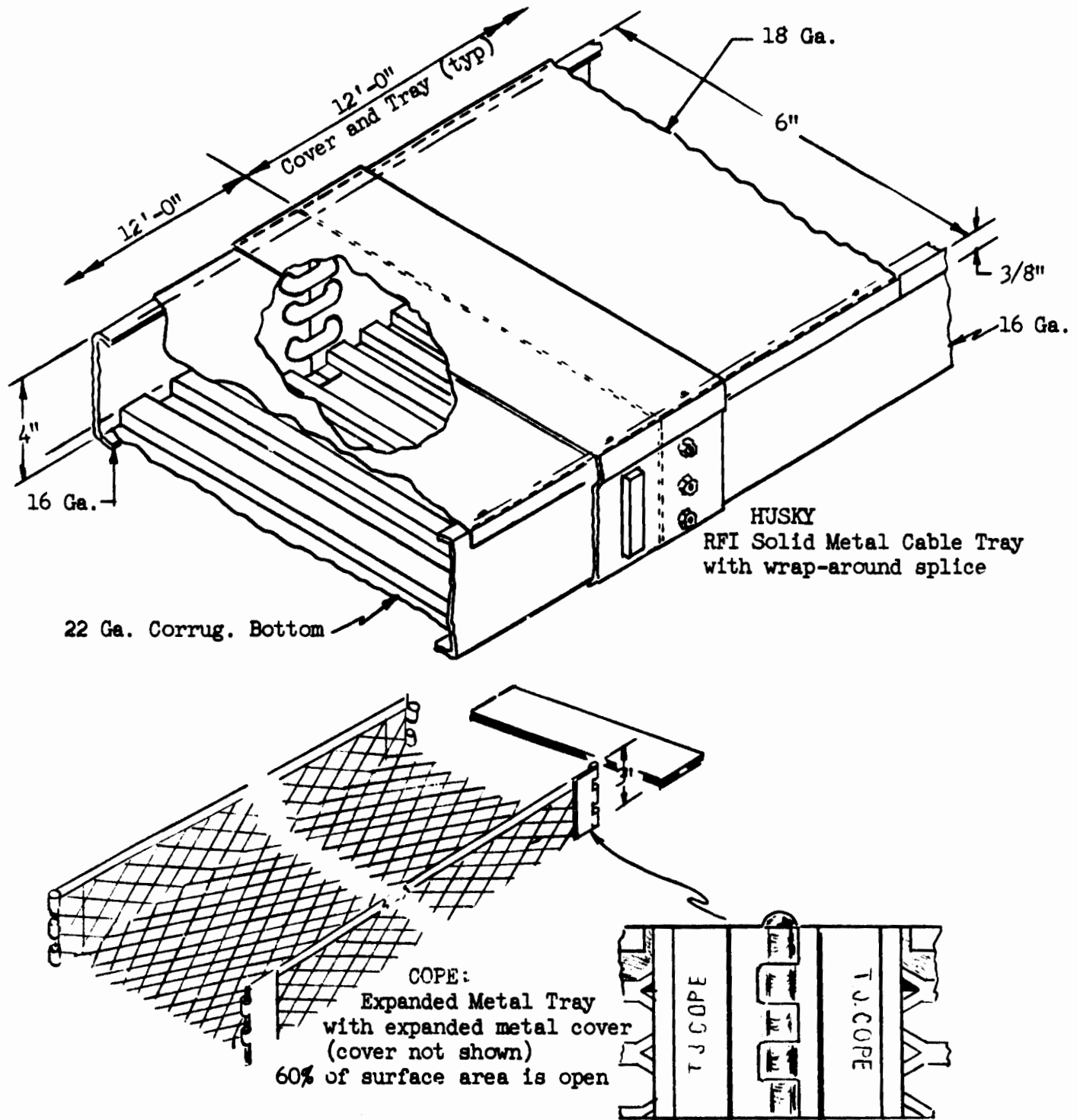
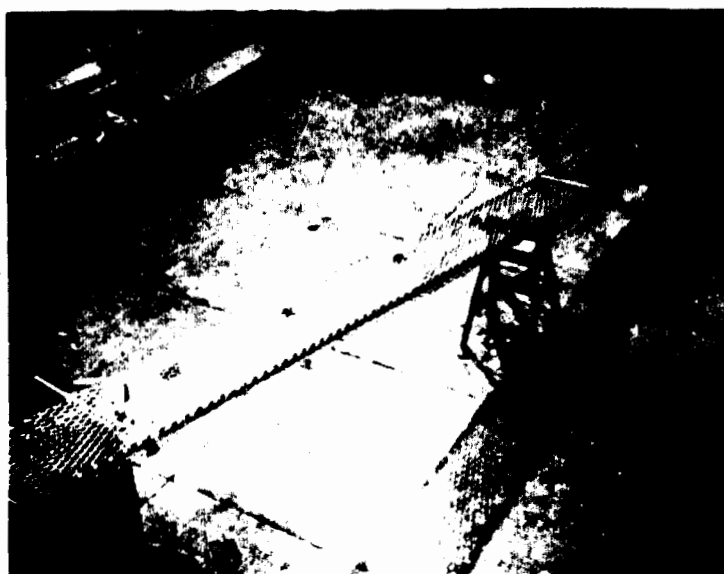

FIGURE 2 Description of Metal Cable Trays

Expanded
Cable
Tray



Solid
Metal
Tray



Measuring End
Connection Box



FIGURE 3 Cable Trays in Place in Test Area

3.0 INDUCED VOLTAGE MEASURING SYSTEM

The induced voltage measuring system was completely shielded with a double shield system. The outer shield was connected to the tray at the measuring end and also at the exit from the shielded room. The inner shield was isolated from the outer shield except at the measurement point in the connection box. The outer shield was terminated at its penetration through the shielded room while the inner shield continued on outside the shielded room to the voltage measuring instrumentation. A toroidal noise filter was used in conjunction with the measuring cable to eliminate unwanted noise signals from flowing on the measuring cable sheath.

Conductor-to-conductor and conductor-to-ground induced voltage measurements were made. Conductor-to-conductor induced voltages were measured by means of a differential type of measurement. Each conductor voltage was fed to one of two input channels of a differential type D Tektronix preamplifier and the difference between the voltages to ground appearing on each of these two measuring leads was displayed on a 535A Tektronix oscilloscope. The input load resistance across the conductors at the time of measurement was 100 ohms. The conductor-to-ground voltages were measured using a 75 ohm measuring system and only one channel of the Type D preamplifier.

4.0 INJECTED CURRENT TESTS AND APPLIED CURRENT WAVE

The current pulse used for this investigation had an effective rise time of 1.0 microsecond and decayed to half value in approximately 55 microseconds. The current wave measurement was made with an 0.0365 ohm non-inductive resistance shunt placed in series with the cable tray and ground with all other grounds removed. Oscillograms of this wave shape are shown in Figure 4. The peak current amplitude was 1480 amperes.

The pulse magnetic field which couples the conductors in the tray is produced by injecting the current pulse at one end of the tray allowing it to flow to ground at the other end of the tray.

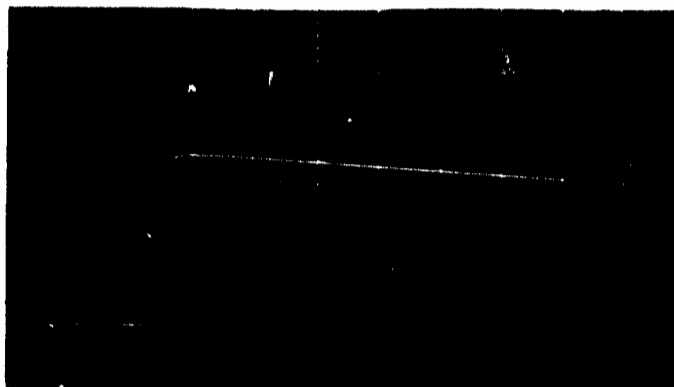

2 μ s/div sweep rate
547 amps/div amplitude calibration

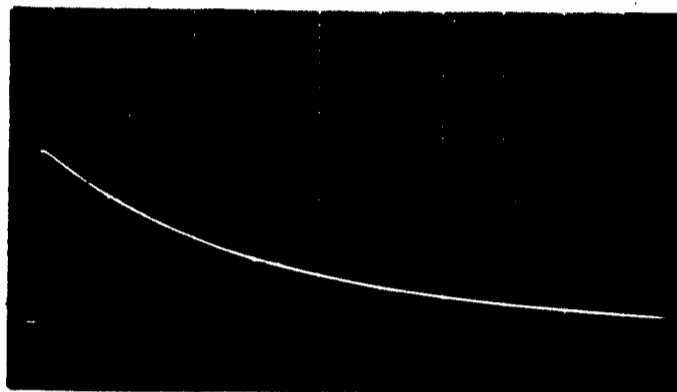

20 μ s/div sweep rate
547 amps/div amplitude calibration

FIGURE 4 . Wave Shape of Injected Current Pulse
Applied Pulse Current - 1480 amperes

5.0 REVIEW OF RELATED PAST WORK

It has been shown¹ that when pulse current flows on a conduit, the conductors within the conduit are subjected to a leakage flux which induces a voltage between conductor and ground. The flux penetrates at such areas as bends and joints. The flux penetration time through these joints is extremely fast and, therefore, the resultant induced voltage initial peak usually occurs at the time of the maximum rate of change of the leakage flux. In addition to the induced voltage on conductors due to leakage flux there is also a voltage which occurs as a conductor-to-conduit voltage which is basically an IR voltage and is time variant with the rate of current diffusion through the conduit wall. This current diffusion process takes considerably more time than the flux leakage through joints and, consequently, the resulting conductor-to-conduit voltage occurs at a later time. It has been previously determined that the time constant of this voltage rise due to current diffusion through a conduit wall is proportional to the conduit wall thickness squared and the permeability of the material and inversely proportional to the resistivity. The peak induced voltage magnitude is a function of the peak current, conduit resistance, permeability, and the shape of the current wave.

Since these voltage transients can propagate throughout the electrical system², the magnitude and wave shape of both voltage peaks are of interest. The experimental program, thus far, has evaluated steel conduit in several different arrangements and joint conditions, wrought iron conduit, EMT conduit, and aluminum conduit. Also tested was aluminum armored shielded cable, Sealtite[®] flexible tubing, standard electrical flexible tubing, carbon steel flexible tubing, and stainless steel flexible tubing. The results of these tests are reported in Reference 2. Evaluations were made by using both an injected current method and an H-field exposure method.

[®] Registered trademark of Anaconda Metal Hose Company

6.0 HUSKY RFI SOLID METAL CABLE TRAY

The cable tray was placed in the test area as shown in Figure 1. A twisted pair, three-conductor cable was randomly placed in the tray and the conductors connected to the tray at the current pulse generator end. The induced voltages measured on the conductors during the current injection tests are given in Table 1. Typical oscillograms are shown in Figure 5.

TABLE 1
INDUCED VOLTAGES ON TWISTED PAIR CONDUCTORS
IN SOLID METAL CABLE TRAY

Applied Peak Current Pulse - 1480 amperes

<u>Conductors Measured</u>	<u>Volts</u>		<u>Time of 2nd Peak</u>
	<u>1st Peak</u>	<u>2nd Peak</u>	
1 - Grd	0.64	0.12	260 μ s
2 - Grd	0.70	0.12	260 μ s
3 - Grd	0.74	0.12	260 μ s
1 - 2	0.04	none	
2 - 3	0.125	none	

As can be noted from the table above and the oscillograms, the first peaks in both the conductor-to-ground and conductor-to-conductor tests occur in a fraction of a microsecond during the maximum rate of change of flux which leaks into the tray and couples the closed loop formed by the conductor and tray. The second peak appears on each of the conductor-to-ground voltage measurements at the same time, with the same polarity and same magnitude. Therefore, it does not appear between conductors. (The longer time conductor-to-conductor oscillogram is not shown.) The second induced voltage peak occurred at 260 microseconds, whereas on conduit¹ which has a much greater wall thickness, the second peak occurred at 3,500 microseconds. In both cases, however, the second peak voltage was lower than the first peak voltage.

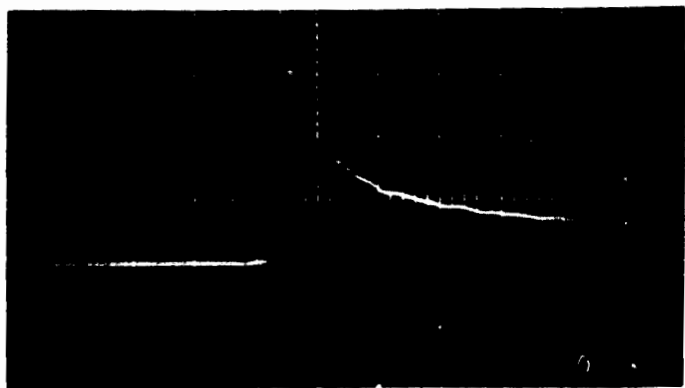

0.2 V/div 1 μs/div
Conductor-to-Ground Voltage

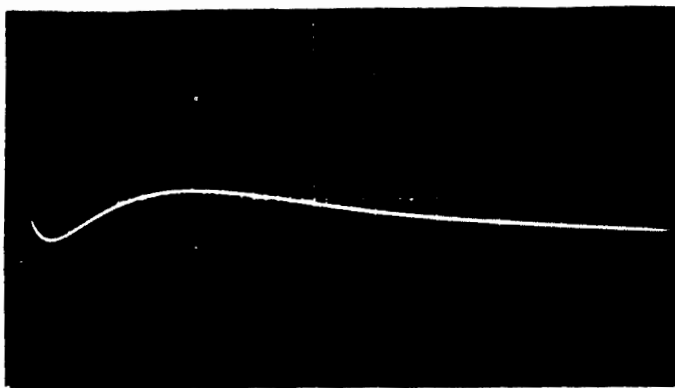

0.1 V/div 100 μs/div
Conductor-to-Ground Voltage

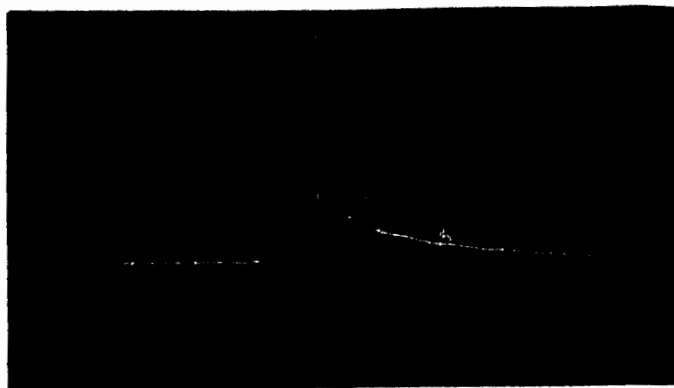

0.05 V/div 1 μs/div
Conductor to-Conductor Voltage

FIGURE 5 Conductor-to-Conductor and Conductor-to-Ground Induced Voltages on Twisted Pair Conductors in RFI Cable Tray. Applied Pulse Current - 1480 amperes peak

7.0 COPE EXPANDED METAL CABLE TRAY WITH COVER

The tray was placed in the test area as shown in Figure 1. The same twisted pair, three-conductor cable as used in the solid metal tray tests was randomly placed in the tray with the conductors connected to the tray at the current pulse generator end. The induced voltages measured on the conductors during the current injection tests are given in Table 2. Typical oscillograms are shown in Figure 6.

TABLE 2

INDUCED VOLTAGES ON TWISTED PAIR CONDUCTORS IN EXPANDED METAL CABLE TRAY HAVING 60% OPEN SURFACE AREA

Applied Peak Current Pulse - 1480 amperes

<u>Conductors Measured</u>	<u>Volts</u>	
	<u>1st Peak</u>	<u>2nd Peak</u>
1 - Grd	30	none
2 - Grd	30	none
3 - Grd	30	none
1 - 2	0.40	none
2 - 3	0.40	none

Immediately apparent is the absence of the second peak induced voltage in the conductor-to-ground measurements. This is because there is no long time flux diffusion through the leaky open material. Comparing conductor-to-ground voltages between the solid metal tray and the expanded metal tray, the shielding effectiveness of the solid metal tray was 32.5 dB higher. One of the objectives of this experiment was to determine this difference. From a conductor-to-conductor viewpoint, the difference was 10 dB, but more significant, the induced voltages measured were quite small, being less than 0.5 volts.

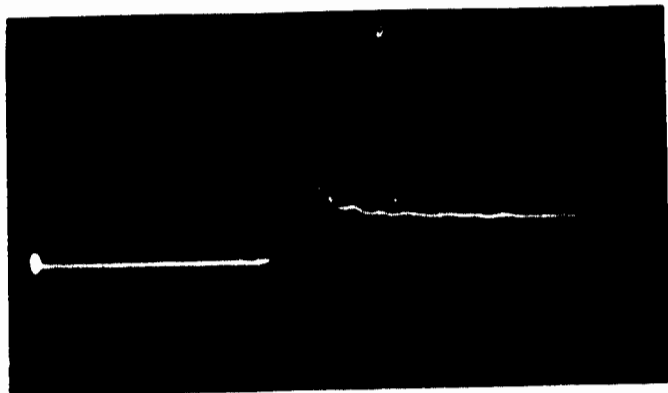

10 V/div 1 μs/div
Conductor-to-Ground Voltage

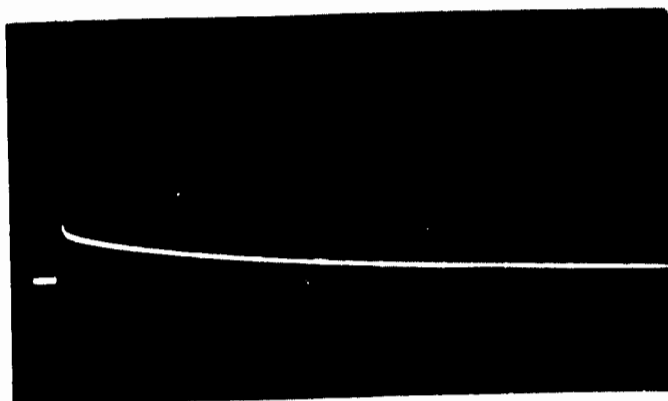

10 V/div 10 μs/div
Conductor-to-Ground Voltage

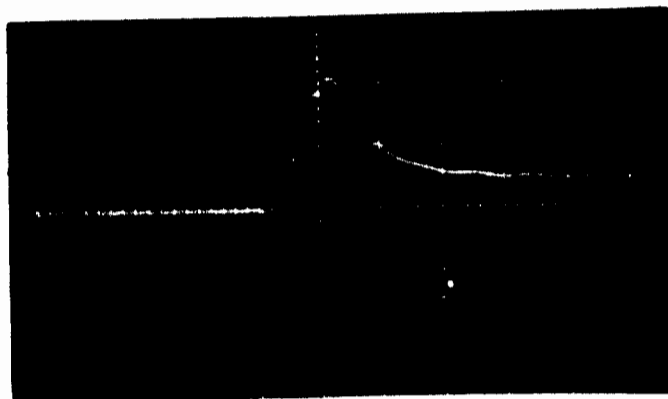

.2 V/div 1 μs/div
Conductor-to-Conductor Voltage

FIGURE 6 Conductor-to-Conductor and Conductor-to-Ground Induced Voltages on Twisted Pair Conductors in Expanded Metal Cable Tray. Applied Pulse Current - 1480 amperes

7.1 Expanded Metal Cable Tray - Shielded Twisted Pair

The three-conductor cable was removed from the tray and replaced by a spirally shielded, twisted pair cable. The conductors were connected to the tray at the current pulse generator end while the shield was connected to the tray at both ends. The induced voltages measured on the conductors during the injected current tests are given in Table 3.

TABLE 3

INDUCED VOLTAGES ON SHIELDED, TWISTED PAIR CONDUCTORS
IN EXPANDED METAL CABLE TRAY HAVING 60% OPEN AREA

Applied Peak Current Pulse - 1480 amperes

<u>Conductors Measured</u>	<u>Volts</u>		<u>Time of 2nd Peak</u>
	<u>1st Peak</u>	<u>2nd Peak</u>	
C - G	2.7	2.7	18 μ s
C - C	0.19	none	

As can be noted, the shielded twisted pair, unlike the unshielded cable, did exhibit an induced voltage second peak at 18 microseconds. This longer time induced voltage peak is probably a measure of the IR drop in the shield.

Comparing the induced voltages in Tables 2 and 3, the shield improves the shielding effectiveness of the overall wiring system by about 20 dB in terms of conductor-to-ground voltages and about 6 dB in terms of conductor-to-conductor voltages. Interestingly enough, the expanded metal tray and shielded wire system have a shielding effectiveness which is within 13.5 dB of that measured on the RFI tray on a conductor-to-ground basis and within 4 dB on a conductor-to-conductor basis.

7.2 Expanded Metal Cable Tray - Parallel Pair Wires

For this experiment parallel conductors were placed in the expanded metal tray as shown in the following sketch.

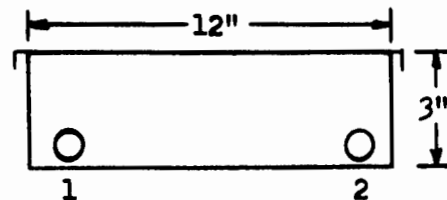

Both conductors were connected to the cable tray at the generator end. The induced voltages measured on the conductors during the injected current tests are given in Table 4.

TABLE 4
INDUCED VOLTAGES ON PARALLEL CONDUCTORS IN
EXPANDED METAL CABLE TRAYS HAVING 60% OPEN AREA

Applied Peak Current Pulse - 1480 amperes

<u>Conductors Measured</u>	<u>Volts</u>	
	<u>1st Peak</u>	<u>2nd Peak</u>
1 - Grd	68	none
2 - Grd	76	none
1 - 2	8	none

Comparing the parallel pair induced voltages with those measured on the twisted pair, we find about a 2 to 1 increase in the conductor-to-ground voltages and a 20 to 1 increase in the conductor-to-conductor voltages.

8.0 H-FIELD TESTS

Both the solid metal tray and the expanded metal tray were also evaluated for shielding effectiveness in terms of the induced voltage measured in a conductor loop within the trays when the trays were exposed to the same engulfing H-field. For these tests the trays were placed under an H-field radiator as shown in Figure 7. The trays were fitted with parallel pair conductors as shown in the following sketch with the conductors connected together and isolated at the generator end to form a loop.

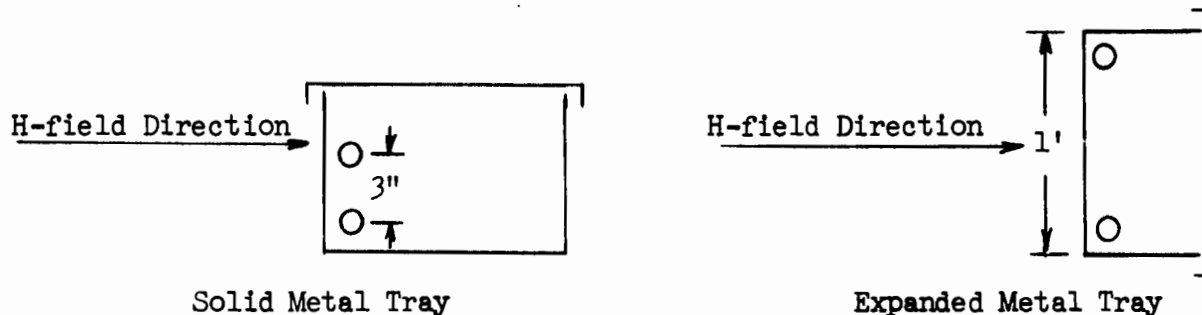

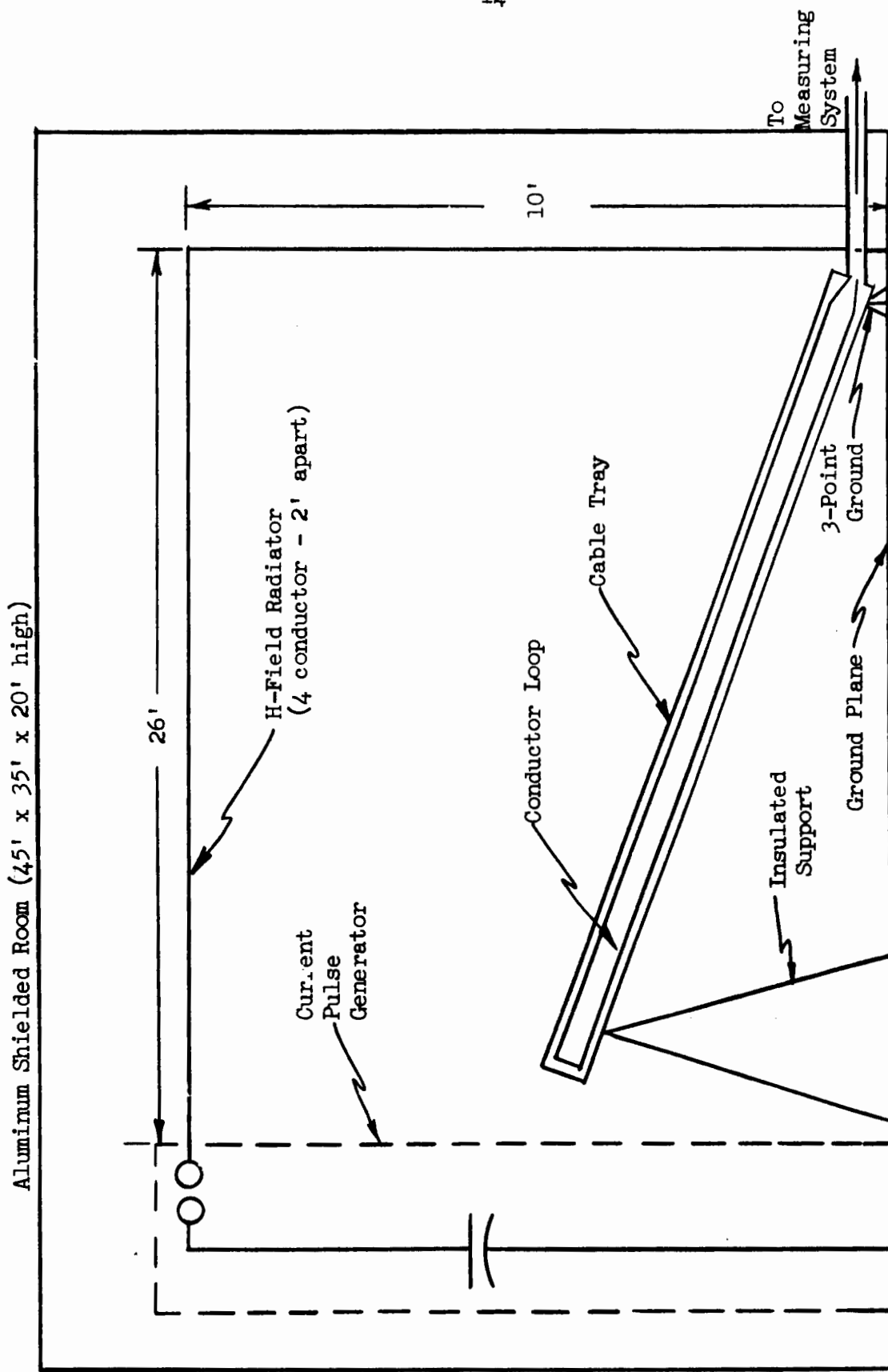

FIGURE 7 Test Area Setup for H-field Tests

This arrangement produced a loop area in the expanded metal tray four times that in the solid metal tray. The conductor loop terminating impedance was the same as that used in the injected current tests.

The H-field which engulfed the trays was non-uniform, ranging from approximately 125 to 175 amperes/meter. The H-field wave shape is shown in Figure 8.

The induced loop voltages measured in the two trays are given in Table 5 and shown in Figure 9.

TABLE 5

COMPARISON OF INDUCED VOLTAGES IN CONDUCTOR LOOPS
CONTAINED IN EXPANDED AND SOLID METAL CABLE TRAYS
ENGULFED BY THE SAME H-FIELD PULSE

Values given are corrected for differences in loop area.

<u>Tray Identification</u>	<u>Volts</u>
Solid Metal Tray	0.52
Expanded Metal Tray	15.0

The difference in shielding effectiveness between the two trays tested under H-field conditions is approximately 30 dB. As indicated earlier (section 7.0), under injected current methods the difference in shielding effectiveness for the conductor-to-ground measurements was 32.5 dB and for the conductor-to-conductor measurements was 10 dB.

9.0 COMPARISON OF SHIELDING EFFECTIVENESS OF VARIOUS RACEWAYS

It was stated in the introduction that the electrical raceway shielding evaluation program which was undertaken under Contract No. DA-49-129-ENG-543 involved many types of conventional raceways, as well as armored, shielded cable. Table 6 is an attempt to compare the significant data obtained from the program since its inception. All the data compared in Table 6 is based on injected current tests using measured values obtained on twisted pair wires only. To make the comparison more realistic and

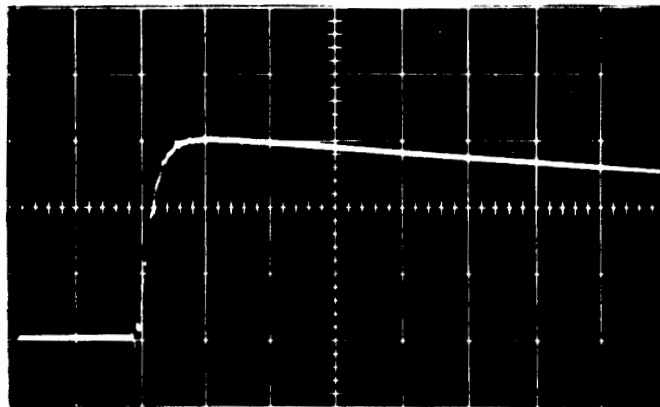

2 μ s/div Sweep Rate

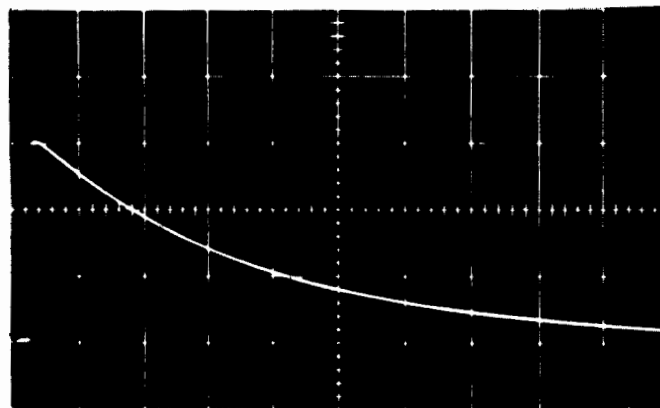

20 μ s/div Sweep Rate

FIGURE 8 Wave Shape of H-field Used in Cable Tray Tests.
Peak magnitude varied from 125 to 175 amperes/meter
in location of tray area.

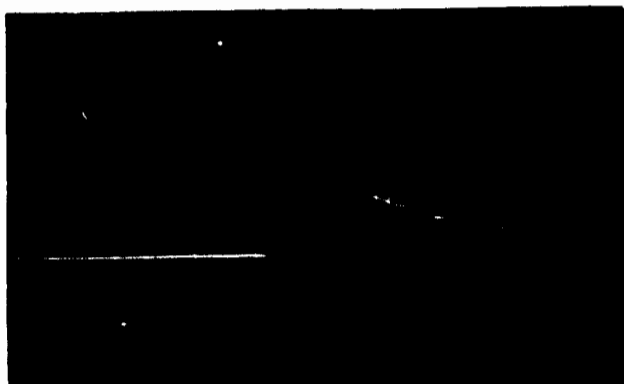

0.05 V/div

1 μ s/div

Solid Metal Tray

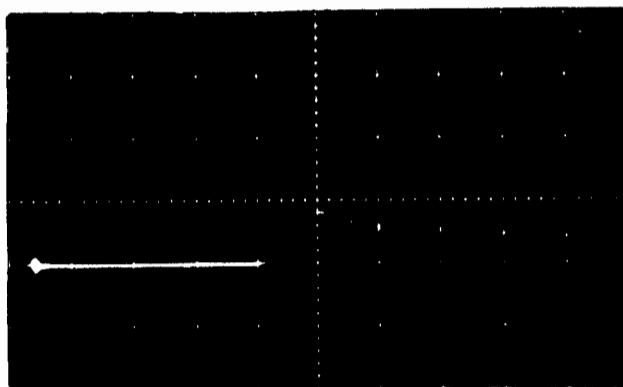

5 V/div

1 μ s/div

Expanded Metal Tray

FIGURE 9

Comparison of Induced Voltages in Conductor Loops
Placed in Solid Metal and Expanded Metal Cable Trays.
Trays Exposed to Same H-Field Pulse.

Loop Area in Expanded Tray 4 Times that in Solid Metal Tray.

INDUCED VOLTAGES ON TWISTED PAIR CONDUCTORS

Based on 100 feet of raceway carrying 1,000 amperes

Conduit or Other Raceway System	Line-to-Ground Volts			Line-to-Line Volts Peak
	1st Peak (< 20 μs)	2nd Peak	Time (μs)	
2" Rigid Steel, welded joints	0.022	0.036	3,500	< 0.002*
2" Rigid Steel, threaded joints	0.083	0.041	3,500	< 0.002*
2" Wrought Iron, threaded joints	0.165	0.090	1,200	< 0.002*
1" Rigid Steel, welded joints	0.021	0.090	3,050	< 0.002*
2" Rigid Steel, threaded joints, one 90° elbow	0.152	0.420	3,500	Not Measured
2" Rigid Steel, threaded joints, one 90° conduit	0.358	0.420	3,500	Not Measured
2" Rigid Steel, one foot section, carbon steel flexible tubing	0.433	0.420	3,500	0.024
Electrical Metallic Tubing	1.33	1.16	350	Not Measured
RFI Cable Trays	2.5	0.50	280	0.43
Aluminum Armored, Shielded Cable armor and shields grounded at both ends	13.0	-	-	1.30
Expanded Metal Cable Tray with cover	105	-	-	1.41
Expanded Metal Cable Tray with cover, shielded twisted pair, both ends of shield grounded	10	-	-	0.70
Sealtite Flexible Tubing	192	152	20	4.50
Greenfield Flexible Tubing	5200	-	-	24.0

* measuring system noise level

usable in terms of necessary extrapolations to other currents or raceway lengths, all the data has been recalculated to compare the induced voltages on conductors in 100 feet of raceway carrying 1,000 amperes peak pulse current having a wave shape similar to that shown in Figure 4.

10.0 SUMMARY

This report presents recent data obtained from injected pulse current tests on cable trays. It also attempts to compare the induced voltages measured on conductors contained within other raceways which were tested. The usefulness of the data in terms of electrical system performance is derived only when it is related to given NEMP environments, electrical system performance requirements, and specific electrical system design. The data has been used in this context for Reference 2.

REFERENCES

1. OCE NEMP PROGRAM, DEVELOPMENT OF CRITERIA FOR PROTECTION OF NIKE-X POWER PLANT AND FACILITIES ELECTRICAL SYSTEMS AGAINST NEMP EFFECTS, MAGNETICALLY INDUCED VOLTAGES ON CONDUCTORS WITHIN CONDUITS AND CABLES, 3 November 1967, Submitted by E. R. Uhlig, General Electric Company, Pittsfield, Mass.

2. OCE NEMP PROGRAM, DEVELOPMENT OF CRITERIA FOR PROTECTION OF NIKE-X POWER PLANT AND FACILITIES ELECTRICAL SYSTEMS AGAINST NEMP EFFECTS, PROTECTIVE MEASURES, 1 December 1967, Submitted by E. R. Uhlig, General Electric Company, Pittsfield, Mass.