

# CONVAIR A

CONVAIR DIVISION OF GENERAL DYNAMICS CORPORATION

AD833211

PRELIMINARY OPERATING  
 AND MAINTENANCE INSTRUCTIONS  
 FOR LAUNCHER ASSEMBLIES  
 USED WITH D - SERIES MISSILES AT  
 TEST SITES MSTs 1-1, SYC S-1, S-2  
 AND AMR 11, 12, 13, and 14  
 AZM-27-290  
 1 July 1959

Rev. A - 9-11-59  
 Rev. B - 10-21-59  
 Rev. C - 12-9-59  
 Rev. D - 1-28-60

*A 25826*  
 SUPERSEDING DOCUMENT AZM-27-010(TN)  
 Dated: 1 August 1958

PREPARED BY *G.K. Jerashian*

APPROVED BY *F.C. Roacker*

CHECKED BY *F.J. [unclear]*

APPROVED BY \_\_\_\_\_

Published by Launcher and Mechanisms Group  
Engineering Department

### REVISIONS

NO.	DATE	BY	CHANGE	PAGES AFFECTED
A	9-15-59	T.Sadowski	Revised Table of Contents	ii, iii
			Revised List of Illustrations	iii, iv
			Revised Figure 1-1	1-2
			Revised Paragraph 1-12	1-4
			Revised Paragraphs 2-7, 2-8, 2-11, 2-12	2-2, 2-3
			Revised Figures 2-1, 2-2	2-6, 2-7
			Revised Paragraph 3-2	3-1

REVISIONS

NO.	DATE	BY	CHANGE	PAGES EFFECTED
A			Removed Paragraphs 3-23, 3-24, 3-25 Renumbered Paragraphs 3-26, 3-27, 3-28, 3-29 Revised Paragraph 4-3 Revised Sections 4-13, 4-14 Revised Paragraphs 4-17, 4-19 Revised Figures 4-1B, 4-2, 4-3 Replaced Figure 4-4 Revised Figure 4-5 Revised Figures 4-11, 4-13, 4-14, 4-15  Added Figure 4-18 Removed Paragraphs 5-4, 5-5 Renumbered Following Paragraphs Revised Figure 5-1 Added Figures 5-2, 5-3, 5-4, 5-5 Revised Paragraph 6-1 Revised Table 8-1  <i>H.K. Jerahian 9-11-59</i> <i>F.C. Roach 9/11/59</i>	3-4 3-5  4-1 4-4, 4-5, 4-6, 4-7 4-9 4-11, 4-12, 4-13 4-14 4-15 4-23, 4-25, 4-26 4-27 4-30 5-1, 5-2 5-1 to 5-4 5-5 5-6, 5-7, 6-1 8-2
B	10-20-59	Jerahian	Revised Sections 4-14 Removed Figure 4-3  <i>H.K. Jerahian 10-21-59</i> <i>F.C. Roach 10/21/59</i>	4-5, 4-6, 4-7, 4-8 4-13
C	12-9-59	Jerahian	Added paragraphs 3-27 and 3-29 Expanded paragraph 4-8 Revised paragraph 4-11 Revised paragraph 4-17 Revised <del>figure</del> 4-1A Revised figure 4-1B Revised paragraph 5-9 Removed paragraph 5-10 Renumbered paragraph 5-12 Revised figure 5-1 Revised figure 5-2  <i>H.K. Jerahian 12-9-59</i> <i>F.C. Roach 12/9/59</i>	3-5 4-2 4-2 & 4-3 4-9 4-10 4-11 5-2 and 5-3 5-3 5-3 5-4 5-5

REVISIONS				
NO.	DATE	BY	CHANGE	PAGES EFFECTED
D	1-25-60	Jerahian	Revised paragraph 4-14 and 4-15 Revised Paragraph 5-9d Revised Figure 5-1 Removed Firdure 5-2 and 5-3 Revised Section VII Revised Table 8-1 Deleted Table 8-2	4-5,4-6,4-7, 4-8 5-3 5-4 5-5 7-1, 7-2, 7-3 8-2

LIST OF EFFECTIVE PAGES

TOTAL NUMBER OF PAGES IN THIS PUBLICATION IS 66, CONSISTING OF THE FOLLOWING:

PAGE (S)	DATE OF ISSUE
Title	Original
Revision Sheet	Revision C
Sheet A	Original
i thru iv	Original
1-1 thru 1-4	Original
2-1 thru 2-8	Original
3-1 thru 3-5	Revision C
4-1 thru 4-30	Revision C
5-1 thru 5-7	Revision C
6-1	Original
7-1 thru 7-3	Original
8-1 thru 8-2	Original

## AZM-27-290

## TABLE OF CONTENTS

Section		Page
I	GENERAL DESCRIPTION .....	1-1
	1-1 Introduction to Manual .....	1-1
	1-5 Purposes of Launcher Assembly (Model 7-80).....	1-1
	1-7 General Description of Launcher Assembly.....	1-1
	1-9 Composite Description of Launcher Subassemblies.....	1-3
	1-12 List of References.....	1-3
II	FUNCTIONAL DESCRIPTION OF LAUNCHER .....	2-1
	2-1 Launcher Assembly .....	2-1
	2-3 Launcher Mounting and Support .....	2-1
	2-5 Holddown and Release Mechanism .....	2-1
	2-6 General Description .....	2-1
	2-7 Detailed Description .....	2-2
	2-13 Missile Support Arm Snubbers .....	2-3
	2-17 Center Supports .....	2-3
	2-19 Auxiliary Supports .....	2-4
	2-21 Service Lines .....	2-4
	2-23 Service Line Connections .....	2-4
	2-25 Propellant Fill and Drain Line Supports .....	2-4
	2-27 Static Firing Links .....	2-4
	2-29 Umbilical Plug Retract Mechanism .....	2-5
	2-31 Functional Description of Missile Nacelle Door Lanyards .....	2-5
III	FUNCTIONAL DESCRIPTION OF ASSOCIATED EQUIPMENT AND SYSTEMS .....	3-1
	3-1 General .....	3-1
	3-4 Launcher Hydraulic and Pneumatic System .....	3-2
	3-6 Support and Balance System .....	3-2
	3-9 A-frame Actuation System .....	3-2
	3-10 Holddown and Release System .....	3-3
	3-11 Launcher-Associated Electrical Equipment .....	3-3
	3-14 Umbilical Plug Ejection Switches .....	3-3
	3-16 Engine Ignitors and Ignition Detector Brackets .....	3-4
	3-17 Static Ground Plug .....	3-4
	3-18 Gyro Disconnect Plug.....	3-4
	3-19 Propellant Lines.....	3-4

AZM-27-290

TABLE OF CONTENTS (cont)

Section	Page
3-21 Launcher Water Cooling System. . . . .	3-4
3-23 Accessory Pod Cooling Lines. . . . .	3-5
3-25 Turbine Exhaust Deflector. . . . .	3-5
3-27 Functional Description of the Liquid Nitrogen Overflow Ducts. . . . .	3-5
3-29 Functional Description of the Thrust Area Heater Duct. . .	3-5
 IV PREPARATION AND CHECKOUT. . . . .	 4-1
4-1 Setup of Launcher . . . . .	4-1
4-3 Special Tools and Equipment . . . . .	4-1
4-4 Conditions for Adjusting Launcher . . . . .	4-1
4-9 Checkout and Adjustment of Launcher . . . . .	4-2
4-10 Checkout and Adjustment of 7-49065 Links . . . . .	4-2
4-11 Checkout and Adjustment of Centerlines of 7-49021 Support Pins. . . . .	4-2
4-12 Checkout and Adjustment of 7-49006 Auxiliary Support Pins .	4-3
4-13 Checkout and Adjustment of 7-49276 Snubbers (AMR Sites Only)	4-4
4-14 Checkout and Adjustment of 7-49018 Release Mechanism (AMR Sites Only). . . . .	4-4
4-15 Checkout and Adjustment of 7-49021 Support Pins. . . . .	4-8
4-16 Checkout and Adjustment of 7-49005 Auxiliary Supports (AMR Sites Only). . . . .	4-8
4-17 Checkout and Adjustment of the Service Line Coupling Support Assemblies. . . . .	4-9
4-18 Pre-operation Checkout of 7-49005 Auxiliary Supports (AMR Sites Only). . . . .	4-9
4-19 Pre-mating Preparation of Launcher. . . . .	4-9
 V OPERATION. . . . .	 5-1
5-1 Operating Details. . . . .	5-1
5-4 Procedures During Mating of Missile and Launcher. . . . .	5-1
5-5 Connecting Propellant Fill and Drain Valves. . . . .	5-1
5-6 Procedure for Connecting Rise-off Disconnect Fittings. . .	5-1
5-7 Procedures During Missile Erection. . . . .	5-1
5-9 Procedures After Missile Erection. . . . .	5-2
5-10 Pre-Flight Procedures. . . . .	5-3

AZM-27-290  
TABLE OF CONTENTS (Cont)

Section		Page
VI	POST-LAUNCH OPERATIONS .....	6-1
	6-1 Procedures for Securing Launcher after Missile Launch .....	6-1
VII	PREVENTIVE MAINTENANCE .....	7-1
	7-1 Frequency of Launcher Inspection .....	7-1
	7-4 Launcher Lubrication .....	7-1
	7-6 Servicing 7-49276 Launcher Snubbers, AMR only ....	7-2
	7-8 Preventive Maintenance Under Storage Conditions ....	7-2
VIII	TROUBLESHOOTING .....	8-1
	8-1 Use of the Troubleshooting Section .....	8-1
	8-3 Cautions in Troubleshooting .....	8-1

LIST OF TABLES

Number		Page
3-1	Launcher Hydraulic and Pneumatic System Functions .....	3-1
8-1	Troubleshooting the Launcher Mechanism .....	8-2

LIST OF ILLUSTRATIONS

Number	Title	Page
1-1	Missile Launcher .....	1-1
2-1	Holddown and Release Mechanism .....	2-6
2-2	Arm and Mechanism Assembly-Exploded View .....	2-7
2-3	Auxiliary Support Assembly-Exploded View .....	2-8
4-1A	Launcher Rigging and Adjustment .....	4-10
4-1B	Launcher Adjustment .....	4-11
4-2	7-49234 Checkout Fixture Installed on 7-49018 Arm and Mechanism Assembly .....	4-12
4-4	27-49084 Strut locked in Position in Checkout Fixture ....	4-14

LIST OF ILLUSTRATIONS (Cont'd)

Number	Title	Page
4-5	Missile Support Pin Shown Fully Extended from 7-49018 Arm and Mechanism Assembly . . . . .	4-15
4-6	Adjustment of 7-49065 Links. . . . .	4-16
4-7	Release Arm Height Adjustment at Static Test Sites . . . . .	4-17
4-8	Release Arm Height Adjustment at AMR Sites, 11, 12, 13 and 14. . . . .	4-18
4-9	Adjustment of Distance in a Horizontal Plane Between Centerline of 7-49021 Support Pins and Vertical Load Cell Centerlines . . . . .	4-19
4-9A	Main Support Arm Pivot Bearing Exploded View . . . . .	4-20
4-10	Adjustment of Distance Between Centerline of 7-49006 . . . . .	4-21
	Auxiliary Support pins and Centerline of Z load cells. . . . .	4-21
4-10A	Auxiliary Support Adjustment Exploded View . . . . .	4-22
4-11	Missile Support Arm Shown Rotated and Fully Compressing Snubber. . . . .	4-23
4-12	Uplock Adjustment. . . . .	4-24
4-13	Arm and Mechanism Assembly-Missile-Support Pin Locked in Extended Position. . . . .	4-25
4-14	Arm and Mechanism Assembly-Missile-Support Pin Unlocked in Extended Position. . . . .	4-26
4-15	Arm and Mechanism Assembly-Missile-Support Pin Fully Retracted . . . . .	4-27
4-16	Missile Support Pin Adjustment . . . . .	4-28
4-17	Auxiliary Support Frame Adjustment . . . . .	4-29
4-18	Position Block Installed on 7-49018 Arm and Mechanism Assy . . . . .	4-30
5-1	Adjustment of Rise-off Disconnect Panels . . . . .	5-4
5-2	Adjustment of Rise-off Disconnect Panels . . . . .	5-5
5-3	Suggested Go or Nogo Gauge . . . . .	5-5
5-4	Adjustment of Rise-off Disconnect Panels . . . . .	5-6
5-5	Checkout of Vertical Location of Missile . . . . .	5-7
7-1	Lubrication Chart. . . . .	7-3

(A)

## SECTION I

## GENERAL DESCRIPTION

1-1. INTRODUCTION TO MANUAL

1-2. This manual provides operating and maintenance instructions for the launcher used with D-Series missiles at flight test sites AMR 11, 12, 13, and 14, and static test sites MSTs 1-1, SYC S-1 and S-2. The instructions are based on information available on the date of publication and are interim in nature. The manual will be revised as additional information is developed through actual operating and maintenance experience at the factory and the test sites.

1-3. Personnel concerned with operation or maintenance of this equipment can contribute to the effectiveness of the revised manuals by forwarding comments and suggestions to the cognizant design engineer.

1-4. Minor variations exist between the flight test launchers (AMR) and the static test launchers. These variations result in slightly different procedures noted in the appropriate sections of this manual.

1-5. PURPOSES OF LAUNCHER ASSEMBLY (MODEL 7-80).

1-6. The primary purposes of the launcher assembly at the test sites specified in Paragraph 1-2 are: (1) to engage a horizontal missile and rotate with it to a vertical position within the service tower; (2) to support and release the missile during launching; (3) to support and restrain the missile during static firing tests; and (4) to provide support for service lines, propellant fill and drain lines, and electrical connections.

1-7. GENERAL DESCRIPTION OF LAUNCHER ASSEMBLY

1-8. The missile launcher assembly (Figure 1-1) is a heavy-walled tubular-welded structure approximately 22 feet long, 16 feet wide, and 16 feet high, weighing about 30 tons. It consists of the following sub-assemblies:

- a. Two heavy-walled, U-shaped, tubular-welded structures (7-49076).
- b. Two tubular center supports (7-49077).
- c. Two arm and mechanisms assemblies (7-49078).
- d. Two holddown and release cylinders (7-89366).
- e. Two auxiliary supports (7-49005).



1-9. COMPOSITE DESCRIPTION OF LAUNCHER SUBASSEMBLIES. The main rectangular frame, composed of the two U-shaped structures (7-49076) and the two tubular center supports (7-49077), has a tripod frame mounted on each corner. A pair of these tripod frames, on each end of the main frame, forms a stanchion at each end on which each arm and mechanism assembly (7-49018) is mounted. The arm and mechanism assemblies consist of two wishbone-shaped housings each of which is constructed of heavy welded-steel plate and weighs approximately 3600 pounds. Missile hold-down pin and pin-actuating mechanisms are contained in each of these housings. A holddown and release cylinder (7-89366) connects the bottom of each arm and mechanism assembly to the base of the launcher. These cylinders are pressurized to hold the missile captive. The cylinders are vented at launch. As the missile rises, it rotates the arm and mechanism assemblies about their pivot points at the top of the end stanchions. This action retracts the holddown pins through a mechanical linkage, and the outward swing of the arm and mechanism assemblies is arrested by two snubbing cylinders mounted on the erector trunnion frame assembly (7-95050). At static test sites, two 7-49197 links are installed instead of the 7-89366 cylinders. These links are used to facilitate installation of a missile.

1-10. Four static-firing links (7-49070) are provided, weighing approximately 1500 pounds each. These links are adjustable turnbuckles which attach to the arm and mechanism assembly and to the main rectangular frame at the base of the launcher. Locks are provided on each link to lock the turnbuckles at the desired length.

1-11. A hinged auxiliary support is mounted on each side of the main rectangular frame which serves to balance the erected missile. Each auxiliary support (7-49005) consists of a tripod, a vertical support pin (7-49006) and an actuating cylinder. The 7-49006 vertical support pins are mounted in the apexes of the auxiliary support (7-49005) and are interconnected and pressurized to provide the missile-stabilizing system. At launch, these auxiliary supports are pneumatically swung outward to the missile-drift-clearance position as the missile clears the auxiliary support pins.

1-12. LIST OF REFERENCES:

a. Missile Launcher Assembly	7-49002
b. Launching Release Mechanism Support	7-49076
c. Center Launching Release Mechanism Support	7-49077
d. Missile to Launcher Service Lines and Auxiliary Support	7-49005

e.	Missile Support Arm and Mechanism Assembly	7-49018
f.	Launcher Structure Alignment Link Assembly	7-49065
g.	Static Firing Missile Restraining Link Assembly	7-49070
h.	Pod Umbilical Plug Retracting Mechanism Installation	27-49300
i.	Hydraulic and Pneumatic Equipment Installation	7-89000
j.	Launcher Instl AMR #11	7-96006
k.	Launcher Instl AMR #12	7-96001
l.	Launcher Instl AMR #13	7-96007
m.	Launcher Instl AMR #14	7-96002
n.	Launcher Instl S-1	7-96000
o.	Launcher Instl S-2	7-96008
p.	Procedure for Erecting Missile XSM-65A in Tower	ZM-7-200E(TN)
q.	Launcher Pneumatic and Hydraulic System	ZM-7-516 (TN)

(A)

## SECTION II

## FUNCTIONAL DESCRIPTION OF LAUNCHER

2-1. LAUNCHER ASSEMBLY.

2-2. The launcher assembly incorporates certain mechanical, hydraulic, and pneumatic devices which function synchronously to raise a missile to a vertical position, support and balance it in the vertical position, hold it down during static tests, and hold it down until releasing it at the optimum thrust value during a launching operation. For instructions on erecting missile in tower, see Convair Report ZM-7-200E(TN).

2-3. LAUNCHER MOUNTING AND SUPPORT.

The launcher is mounted on the site flame deflector structure by four vertical and three horizontal load cells during engine test runs and launching operations. The load cell system is used to measure the weight of the missile, the thrust of the engines, and any horizontal loads.

2-4. During the erection of the missile, the launcher is supported by the 7-95050 erector trunnion frame assemblies, which also serve as pivot points for the missile-launcher-trailer-erector combination during this operation.

2-5. HOLD DOWN AND RELEASE MECHANISM. (See figure 2-1)

2-6. GENERAL DESCRIPTION. For launching, the large release arms are held in their missile-support position by the mechanical bottoming of the release cylinders (7-89366). With the engines at full thrust, the missile is restrained from rising by pneumatic pressure on the upper side of the pistons in the two release cylinders. For launching, this pressure is relieved through an orifice at a predetermined rate which limits the initial acceleration of the missile. As the pneumatic restraint drops below the net thrust, the missile starts rising. At approximately 6.2 inches of rise, the missile restraint has dropped to zero and the mechanical linkage that keeps the missile and release arms engaged starts retracting the support pins. Pin retraction is completed in the next 2.5 inches of missile rise (8.7 inches of total rise) and the release arms continue to rotate to the snubbed position. Missile thrust, applied through a suitable linkage, is used to retract the support pins and rotate the release arms to the clearance position.

## SECTION II

2-7. DETAILED DESCRIPTION. The missile release mechanism on the launcher consists of the arm and mechanism assembly (7-49018), the holddown and release cylinder (7-89366), and the actuating strut assy. (27-49085). The release mechanism performs the following functions: (A)

- a. Locks the 7-49021 missile support pin in the extended position.
- b. Retracts the 7-49021 pin into the arm at the proper time.
- c. Allows outward rotation of the 7-49018 arm to clear the rising missile.
- d. Limits the load transmitted to the fairing.

2-8. The force required to actuate the mechanism is transmitted from the missile to the mechanism by the 27-49085 actuating strut assembly. This strut assembly rests against the 7-45996 sleeve in the 27-77815 aft nacelle adapter on the missile fairing, aft of the support socket. The other end of the 27-49085 strut assembly is attached to the 7-49028 slotted link through the 7-49019 levers. (A)

2-9. The launch signal, initiated at the blockhouse, opens the valves on the two release cylinders through the action of the system described in paragraph 3-10. As the restraining force supplied by the holddown and release cylinders drops to a value less than the net thrust of the missile, the missile rises and rotates the 7-49018 arms about their pivot. As the missile rises, the blocks on the 7-49028 links strike the 7-49049 bell cranks. These, in turn, rotate against the 7-49042 links, shearing the lock-wire through the 7-49042 links and the 7-49038 eye, and raise them above the over-center locked position. This action unlocks the 7-49021 missile support pin. When the missile has risen approximately 6.2 inches, the bottom of the slots in the 7-49028 links contacts the bolts in the 7-49046 levers. Additional vertical motion of the links against the 7-49046 levers rotates the 7-49037 shaft. Through the action of the 7-49033 bell crank, the 7-49032 link, and the 7-49022 levers, the pin is pulled into the arm assembly.

2-10. The timing of the mechanism is such that the 7-49042 link and 7-49038 eye are unlocked and the motion of the 7-49021 pin is impending at 6.2 inches of missile rise. The pin is fully retracted at approximately 8.7 inches of missile rise.

2-11. When the 7-49021 pin has been retracted, the 7-49019 levers contact the stops on the 7-49009 arm, and the force supplied by the missile through the 27-49085 strut assembly rotates the 7-49018 arm upward to clear the missile. (A)

## SECTION II

2-12. Uplocks (7-49027) are provided on the 7-49018 arm assembly. These uplocks engage bolts in the 7-49019 levers and prevent the pin-retracting mechanism from rebounding from the retracted position. As the arm assembly is being accelerated away from the missile, the 27-49085 st assys. are disengaged from the 27-77815 aft nacelle adapters on the missile fairing, are swung up against the 7-49051 bumpers on the 7-49019 levers by the action of the 7-49254 springs, and are locked in place by the 7-49024 pins to prevent them from striking the missile fairing. (A)

2-13. MISSILE SUPPORT ARM SNUBBERS.

2-14. The missile support arm snubbers arrest the motion of the missile support arms during the last 24 degrees of arm rotation. The kinetic energy of the arms is dissipated by the snubbers to prevent rebounding of the arms.

2-15. The snubbers are self-contained hydraulic units mounted on the 7-95050 trunnion frame supports and stabilized by spring-loaded braces. The braces align the snubbers with the missile support arm and allow the snubbers to be deflected slightly from the centered position.

2-16. A light return spring maintains the snubber piston rod in the extended position when no load is applied. The spherical rod end fitting engages a spherical socket on the missile support arm after the arm has rotated 116 degrees from the holddown position.

## NOTE

The snubbers are not used at static test sites.

2-17. CENTER SUPPORTS.

2-18. The 7-49077 center supports are tubular members attached between the two main U-shaped support structures (7-49076). These members are designed to bend as the main missile support points are deflected outward by any radial deflection of the missile thrust structure.

## SECTION II

2-19. AUXILIARY SUPPORTS

2-20. The two auxiliary supports (7-49005) are mounted at an angle of 90 degrees to the main holddown points. The auxiliary supports receive the balance of the missile weight and a large part of the load along the Y axis. The vertical pins (7-49006) at the top of the auxiliary supports are installed as part of a hydraulic and pneumatic system. This system limits the load transmitted to the missile structure at the attachment point of the auxiliary support pins 7-49006 and maintains the missile in a vertical position. During launching, the auxiliary supports are rotated outward 30 degrees to clear the missile.

2-21. SERVICE LINES

2-22. All service lines (pressurization, hydraulic, propellant, etc.) are connected to the missile through separable fittings, half of each fitting being mounted to the launcher center support or main support sections. Supports and fittings provide for variations in the relative positions of the two halves of the fittings. This is to allow for manufacturing variations and deflections caused by changes in temperature, weight, or line pressures. At approximately 2 inches of missile rise at launching, all lines are disengaged.

2-23. SERVICE LINE CONNECTIONS.

2-24. The launcher-to-missile service-line disconnects are located in two groups: one on the 7-49077 center support in quadrants I and II and the other on the 7-49077 center support in quadrants III and IV. The ground half of each fitting may be individually aligned horizontally to match the airborne missile valves. The valve mounting plates are supported by links which allow lateral motion of the valves relative to the launcher base.

2-25. PROPELLANT FILL AND DRAIN LINE SUPPORTS.

2-26. The launcher propellant fill and drain lines and valves are located in quadrants III and IV. They are attached to the launcher main supports.

2-27. STATIC FIRING LINKS.

2-28. The static firing links (7-49070) are used during captive engine tests to maintain securely the arm and mechanism assembly (and therefore the missile) in the holddown position.

## SECTION II

2-29. UMBILICAL PLUG RETRACT MECHANISM .

2-30. The electrical cable umbilical plugs, which attach to the missile, are supported and retracted by portions of the launcher structure. The retraction mechanism mounted on the 7-49018 arm assembly retracts the pod umbilical plugs. The upward movement of the missile, upon launch, ejects the plugs on the booster section. Lanyard cables are attached to the launcher structure for the purpose of mechanically ejecting the plugs in the event of an electrical ejection failure.

2-31. FUNCTIONAL DESCRIPTION OF MISSILE NACELLE DOOR CLOSING LANYARDS

The missile nacelle doors are held in the open position while the missile is in the launcher by four pins which fit into lugs on the doors and the aft nacelles. Attached to each pin is a steel cable lanyard, the lower end of which is connected to the launcher structure. When the missile reaches an altitude of approximately 5 feet during launching, the lanyards become taut and the four pins are withdrawn. The springs provided on each nacelle door then pull the doors to the closed position.

The upper or pin ends of the lanyards are secured with lockwire to prevent accidental release of the nacelle door closing lanyards during pre-launch operations.

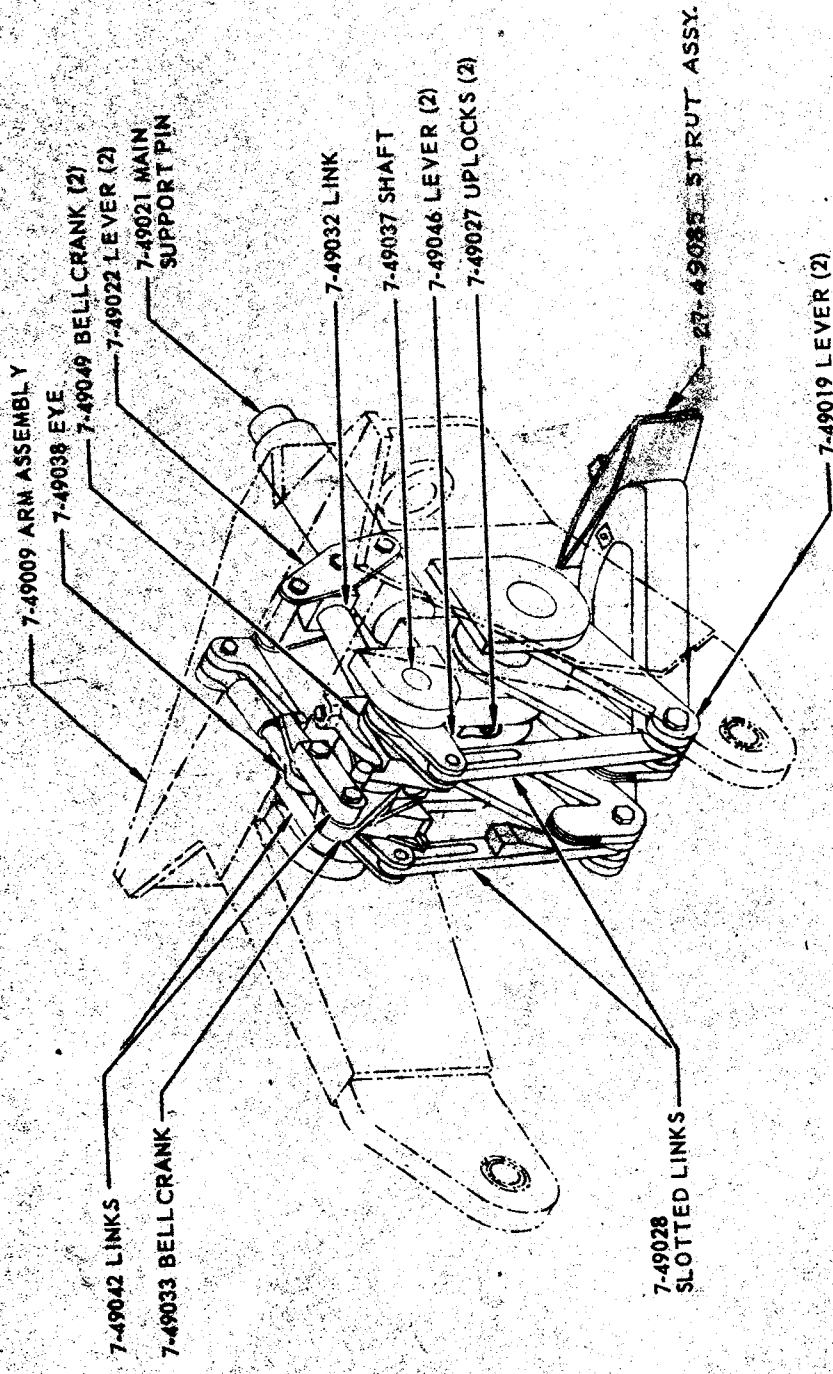
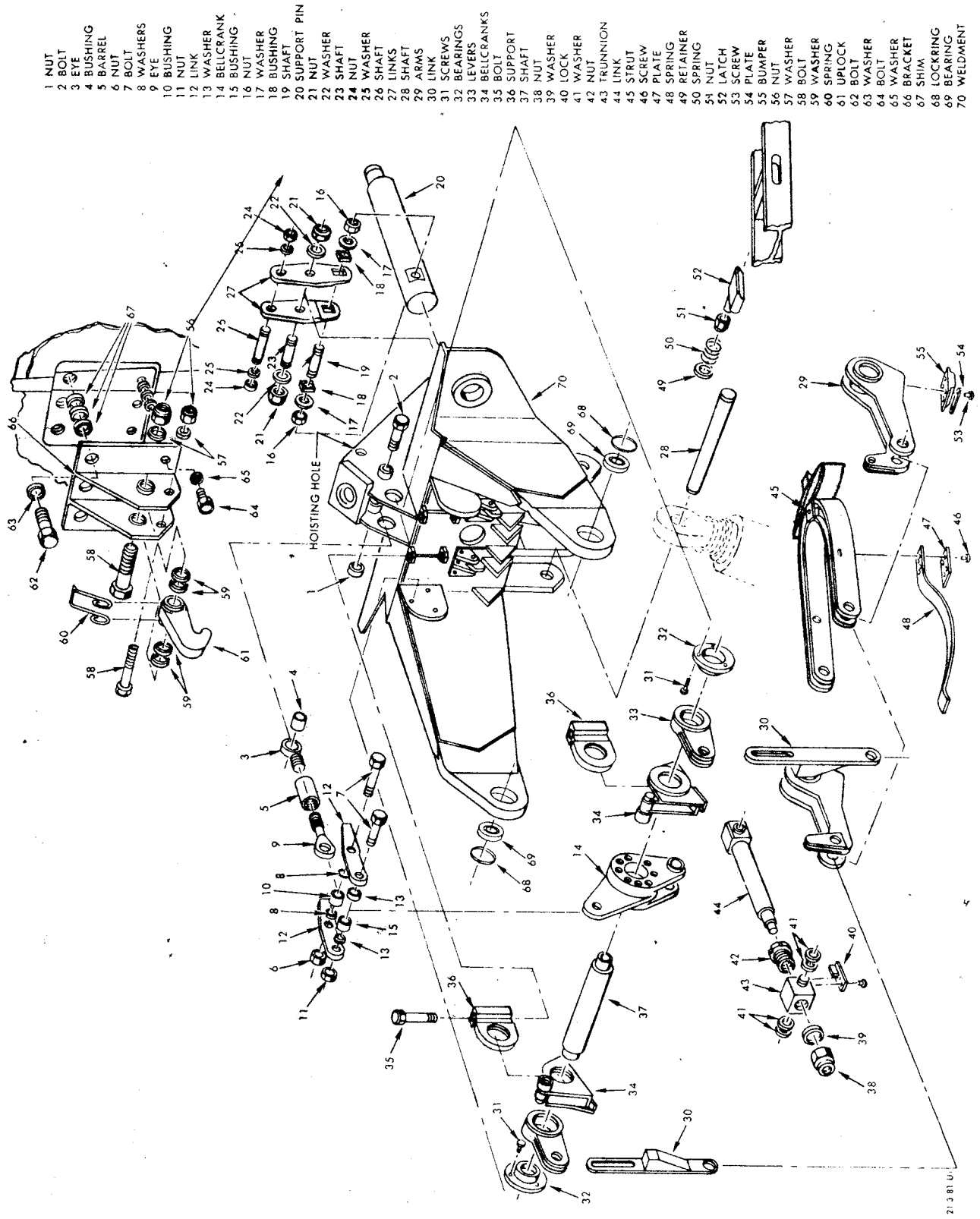
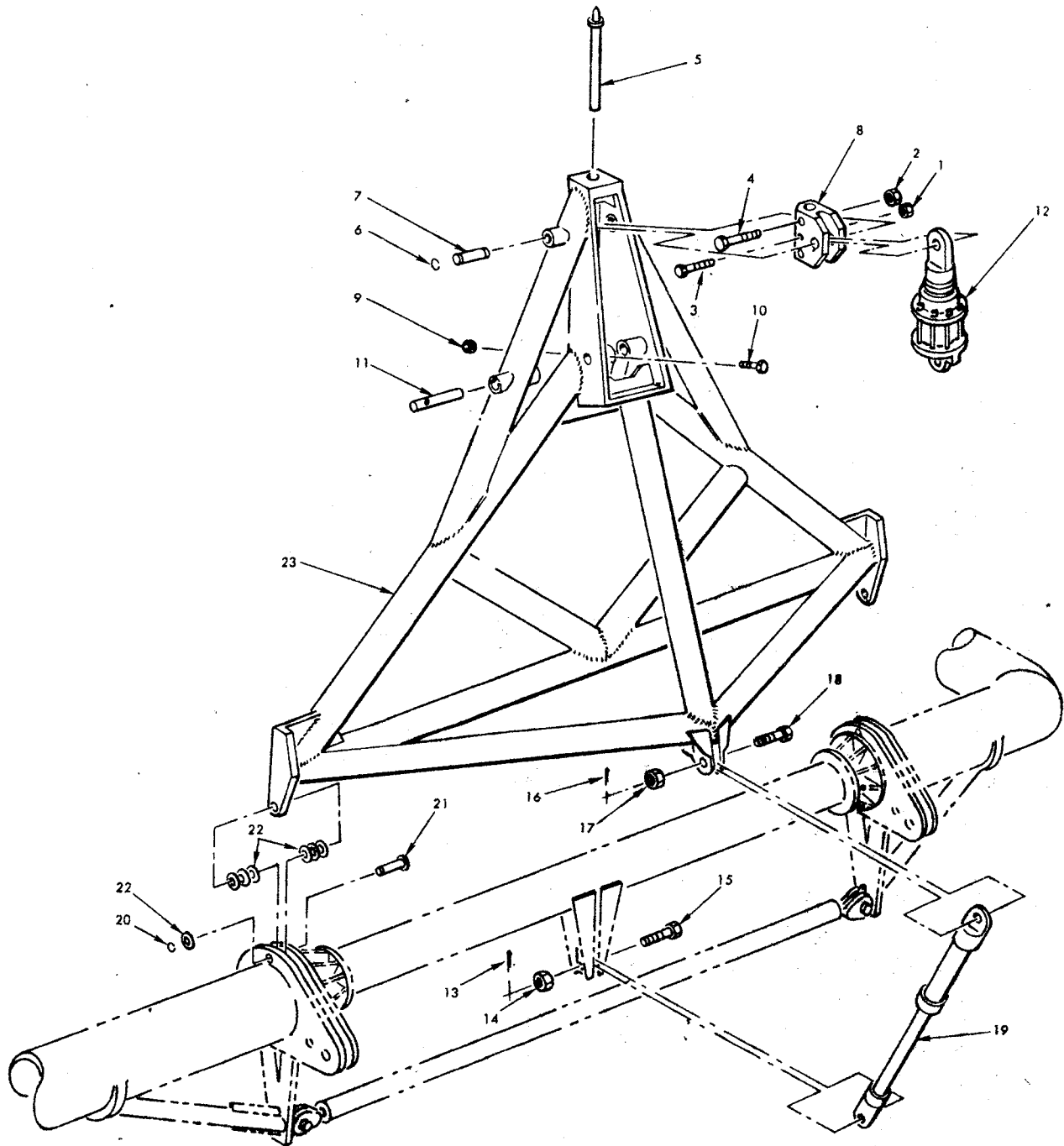

Figure 2-1. HORN-DOWN AND RELEASE MECHANISM



- 1 NUT
- 2 BOLT
- 3 EYE
- 4 BUSHING
- 5 BARREL
- 6 NUT
- 7 BOLT
- 8 WASHERS
- 9 EYE
- 10 BUSHING
- 11 NUT
- 12 LINK
- 13 WASHER
- 14 BELLCRANK
- 15 BUSHING
- 16 NUT
- 17 WASHER
- 18 BUSHING
- 19 SHAFT
- 20 SUPPORT PIN
- 21 NUT
- 22 WASHER
- 23 SHAFT
- 24 NUT
- 25 WASHER
- 26 SHAFT
- 27 LINKS
- 28 SHAFT
- 29 ARMS
- 30 LINK
- 31 SCREWS
- 32 BEARINGS
- 33 LEVERS
- 34 BELLCRANKS
- 35 BOLT
- 36 SUPPORT
- 37 SHAFT
- 38 NUT
- 39 WASHER
- 40 LOCK
- 41 WASHER
- 42 NUT
- 43 TRUNNION
- 44 LINK
- 45 STRUT
- 46 SCREW
- 47 PLATE
- 48 SPRING
- 49 RETAINER
- 50 SPRING
- 51 NUT
- 52 LATCH
- 53 SCREW
- 54 PLATE
- 55 BUMPER
- 56 NUT
- 57 WASHER
- 58 BOLT
- 59 WASHER
- 60 SPRING
- 61 UPLOCK
- 62 BOLT
- 63 WASHER
- 64 BOLT
- 65 WASHER
- 66 BRACKET
- 67 SHIM
- 68 LOCKRING
- 69 BEARING
- 70 WELDMENT

Figure 2-2. ARM AND MECHANISM ASSEMBLY - EXPLODED VIEW



- |                  |                        |                       |
|------------------|------------------------|-----------------------|
| 1 NUT            | 9 NUT                  | 17 NUT                |
| 2 NUT            | 10 BOLT                | 18 BOLT               |
| 3 BOLT           | 11 PIN                 | 19 ACTUATING CYLINDER |
| 4 BOLT           | 12 STABILIZER CYLINDER | 20 LOCKRING           |
| 5 STABILIZER PIN | 13 COTTER PIN          | 21 PIN                |
| 6 LOCKRING       | 14 NUT                 | 22 WASHER             |
| 7 PIN            | 15 BOLT                | 23 AUXILIARY SUPPORT  |
| 8 ACTUATING ARM  | 16 COTTER PIN          |                       |

21.3-91(U)

Figure 2-3. AUXILIARY SUPPORT ASSEMBLY - EXPLODED VIEW

## SECTION III

FUNCTIONAL DESCRIPTION OF  
ASSOCIATED EQUIPMENT AND SYSTEMS3.1. GENERAL.

3.2. The following equipment and systems are directly associated with the launcher:

- a. Launcher hydraulic and pneumatic system.
- b. Electrical equipment.
- c. Propellant lines.
- d. Launcher water cooling system.
- ~~Accessories for the launcher assembly.~~
- e. Accessory pod cooling lines.
- f. Turbine exhaust deflectors.

3.3. The functions of the foregoing equipment and systems are briefly described in this section. Special emphasis has been placed on their specific relationship to the launcher assembly.

Table 3-1. Launcher Hydraulic and Pneumatic System Functions

SYSTEM	HARDWARE CONTROLLED	ACTUATING CYLINDER	PURPOSE
Support and balance	7-49006 auxiliary support pins	7-08267	Maintains missile support and balance
A-frame actuation	7-49005 auxiliary support structure	7-08247	Positions A-frame for mating; retracts A-frame at missile launch
Holddown and release	7-49018 arm and mechanism assembly	7-89366	Accomplishes hold-down and release of missile during launch

## SECTION III

3-4. LAUNCHER HYDRAULIC AND PNEUMATIC SYSTEM.

3-5. The launcher hydraulics and pneumatics may be separated, for clarity, into three separate systems which perform the separated functions shown in table 3-1.

## NOTE

The 7-89366 cylinders and the 7-08247 cylinders are not used at static test sites.

3-6. SUPPORT AND BALANCE SYSTEM. Two combination hydraulic and pneumatic cylinders (7-08267) are mounted on the 7-49005 auxiliary supports. The 7-49006 auxiliary support pins are mechanically connected to these cylinders.

3-7. The hydraulic sections of the 7-08267 cylinders are cross-connected so that vertical motion of one 7-49006 pin results in identical motion of the other pin. This hydraulic action of the system maintains the missile in a vertical position. A temperature compensator is installed in the system to prevent excessive pressures from developing by expansion of the hydraulic fluid.

3-8. The pneumatic section of the two 7-08267 cylinders is pressurized with gas to maintain a force against the auxiliary support fittings of the missile. As the missile is fueled, the cylinders allow the 7-49006 pins to move down in relation to the auxiliary supports. This portion of the system maintains a constant total balance force against the missile.

3-9. A-FRAME ACTUATION SYSTEM. The 7-49005 auxiliary supports (A-frames) are positioned by actuating the two 7-08247 pneumatic cylinders. During mating of missile and launcher, these units may be operated from a panel located in quadrant II below the 7-49076 support. During the launching sequence, the 7-08247 cylinders are pressurized on the piston rod end so that as the missile rises from the 7-49006 auxiliary support pins, the 7-49005 auxiliary supports are retracted. The 7-08247 cylinders may be replaced with the 7-89325 link assemblies to provide an alternative method for adjusting the auxiliary supports during the mating of missile to launcher. The missile may be erected with these links installed, but they must be replaced with the 7-08247 cylinders prior to fueling and launching operations.

## SECTION III

## NOTE

At static test sites the 7-08247 cylinders are not used. The 7-89325 links are used for all operations except during tanking and engine firing. During these operations the links must be removed.

3-10. HOLDDOWN AND RELEASE SYSTEM. The 7-89366 holddown and release cylinders restrain the 7-49018 arm and mechanism assemblies to prevent the missile from rising during the initial stages of the launching cycle. Nitrogen, under high pressure on the upper side of the pistons, prevents the piston rod from moving until the launch signal is given from the blockhouse. The launch signal opens a solenoid valve which permits pneumatic pressure to enter the release system master pneumatic cylinder. The piston rod of this cylinder is mechanically connected to two hydraulic master cylinders. A hydraulic line runs from each master cylinder to the corresponding slave cylinder, which opens the dump valves on the 7-89366 release cylinders. This system ensures that both 7-49018 arm and mechanism assemblies are released simultaneously.

## NOTE

The 7-89366 cylinders are not used at static test sites.

3-11. LAUNCHER-ASSOCIATED ELECTRICAL EQUIPMENT.

3-12. The electrical equipment closely associated with the launcher is as follows:

- a. Umbilical plug ejection switches.
- b. Engine ignitors and ignition detector brackets.
- c. Gyro Disconnect Plug
- d. Static ground plug.

3-13. The electrical equipment listed above is briefly described in the following paragraphs. No attempt is made here to describe the function of this equipment unless the launcher mechanism performs some active function to contribute to the effective operation of the equipment. For identification purposes, each item of electrical equipment is located with reference to launcher quadrants and launcher components.

3-14. UMBILICAL PLUG EJECTION SWITCHES. As the 7-49018 missile support arms rotate upward during launching, two umbilical plug ejection switches are closed. Closing these switches actuates a solenoid on each umbilical plug. These solenoids eject the plugs from the missile. The ~~two~~ umbilical plug ejection switches, one each in quadrants I, III, & IV, are mounted on the 7-49076 supports.

## SECTION III

3-15. In case of an electrical ejection failure at the time appointed for plug retraction, the launcher mechanically releases the umbilical plugs, as follows:

- (1) The pod umbilical plugs located at Station 1133 on each missile accessory pod are retracted by a mechanism mounted on 7-49018 arm ass'y
- (2) The booster section umbilical plugs are retracted by the upward motion of the missile.

3-16. ENGINE IGNITORS AND IGNITION DETECTOR BRACKETS. Brackets for engine ignitors and ignition detector links are provided on the 7-49076 supports and on the 7-49077 center supports.

3-17. STATIC GROUND PLUG. The static ground plug is mounted on the pod in quadrant IV. This plug is disconnected by the action of the missile pod umbilical retraction mechanism during the launching sequence.

3-18. GYRO DISCONNECT PLUG The Gyro Disconnect is pulled away from the missile when the missile reaches an altitude of approximately 42 inches by a lanyard cable which is part of the 27-49002 retraction mechanism. The disconnect is secured to the missile structure with lockwire to prevent inadvertent release before 42 inch rise-off.

3-19. PROPELLANT LINES

3-20. The missile is tanked with fuel and liquid oxygen while it is installed on the launcher. Two pipes, one for fuel and one for liquid oxygen, run up the trunnion supports (7-95050) from the site supply. They run through swivel joints and along the launcher to quadrants III and IV, where they attach to the fill and drain valves.

3-21. LAUNCHER WATER COOLING SYSTEM

3-22. A water spray cooler installation (7-96050) is attached to the 7-49076 launcher support. This system is operated for a time after each static firing to cool the aft end of the missile thrust structure. The cooler installation is also used to cool the launcher after a missile is launched.

3-23. AFT NACELLE SHOCK ABSORBERS

3-24. The aft nacelle shock absorbers are self-contained hydraulic units, mounted on the aft nacelle fairing of the missile, which engage the missile release arm actuating struts (7-49003). These units are designed to limit the load transmitted to the fairing by the support arms.

3-25. Each shock absorber incorporates a spring-loaded orifice plug which opens at a predetermined pressure as the piston is forced down by the 7-49003 strut.

## SECTION III

3-23. ACCESSORY POD COOLING LINES.

3-24. The air cooling ducts which attach to the missile accessory pods are attached to the pod umbilical retracting mechanism of the launcher. As the missile rises at launching, a lanyard cable pulls the cooling ducts away from the pod.

3-25. TURBINE EXHAUST DEFLECTOR

3-26. A turbine exhaust deflector is mounted on the launcher center section (7-49077) in quadrant III. Hot gases from the turbine exhaust are directed into the exhaust deflector, where they are cooled by water sprayed into the deflector from a manifold which surrounds the top opening. The cooled gases are directed down, the deflector and are exhausted into the flame bucket.

3-27. FUNCTIONAL DESCRIPTION OF THE LIQUID NITROGEN OVERFLOW DUCTS

3-28. The liquid nitrogen overflow ducts (2) which attach to the missile thrust barrel, are attached to the 27-49078 lanyard installation located in quadrant I on the launcher. As the missile rises at launching, lanyard cables pull the liquid nitrogen overflow ducts away from the missile thrust barrel.

3-29. FUNCTIONAL DESCRIPTION OF THE THRUST AREA HEATER DUCT

3-30. The 27-80039 thrust area heater duct installation which attaches into the missile fire shield is located in quadrant I on the launcher. As the missile rises at launching, a lanyard cable pulls the thrust area heater duct away.

## SECTION IV

## PREPARATION AND CHECKOUT

4-1. SET-UP OF LAUNCHER.

4-2. In general, the launcher shall be set up in accordance with drawings 7-49002, 7-49018, and 7-49452.

4-3. SPECIAL TOOLS AND EQUIPMENT.

- a. Engineer's transit to level and align launcher.
- b. Plumb bobs.
- c. Level rod graduated in inches.
- d. Steel surveyor's tape.
- e. Four steel bars at least 4 feet long, with a maximum diameter of 1 5/4 inches (may be flattened at one end for use as pry bars).
- f. Two steel bars at least 1 foot long, with a diameter of 7/16 inch.
- g. Spanner wrench, hook, adjustable, 2 to 4-3/4 inch, Williams 474 or equivalent.
- h. Open-end or adjustable wrench to fit 2 1/2-inch nut, 1/2-inch maximum thickness.
- i. Open-end or adjustable wrench to fit a nut 6 1/2 inches across flats.
- j. Special pliers for lock rings, Waldes Kohinoor No. 26 or equivalent.
- k. Spanner wrench, 7-95093, for trunnion shaft.
- l. Strap wrench with 1-inch-wide strap.
- m. Pressure hydraulic system bleeder.
- n. Tower utility hoist or le-torneau diesel electric crane of at least 5 ton capacity.
- o. Hydraulic bleeder hose.
- p. Static-firing link handling sling (7-96077).
- q. Checkout fixture, release mechanism (7-49234). (Not required at static test sites.)

4-4. CONDITIONS FOR ADJUSTING LAUNCHER.

4-5. The launcher is to be mounted on and supported by three side load cells and four vertical load cells. Preliminary leveling adjustments must be made to transfer load from the trunnion shafts to the 4 load cells. Refer to Convair Report ZM-7-200E (TN) for procedures for these preliminary leveling adjustments.

## SECTION IV

4-6. The 7-95042 trunnion shafts are to be disengaged from the launcher. (Refer to Convair Report ZM-7-200E(TN) for procedures to disengage trunnion shafts.)

4-7. The static firing links (7-49070) must be removed. Refer to Convair Report ZM-7-200E(TN) for removal procedure.

4-8. The launcher must be leveled to establish a horizontal base plane through the four Z load cell lugs. (Use an Engineer's Transit to level the launcher.) With the launcher leveled, and with the two auxiliary supports (7-49005) in the vertical position, the launcher must be releveled to establish a horizontal plane with the upper surfaces of 7-49008 caps of 7-49005 auxiliary support. Make adjustment as required by rotating adjustment screws on each Z load cell to vary length. Z load cells should be adjusted in pairs (e.g. Z-1 and Z-2 for 7-49005 support in quadrant I & II and Z-3 & Z-4 for support located in quadrants III & IV).

NOTE

The 7-49005 auxiliary supports are in the vertical position when the following conditions exist:

- (a) The distance in a horizontal plane between the centerline of the 7-49006 auxiliary support pin and the centerline of the 7-49021 main support pins is  $62.17 \pm 0.03$  inches.
- (b) The distance in a horizontal plane between the centerlines of the two 7-49006 auxiliary support pins is  $124.34 \pm 0.03$  inches.

4-9. CHECKOUT AND ADJUSTMENT OF LAUNCHERNOTE

The procedures in Paragraphs 4-10 through 4-19 apply to all sites unless otherwise noted.

4-10. CHECKOUT AND ADJUSTMENT OF 7-49065 LINKS

- a. Verify that 7-49065 links are adjusted so that there is no axial play.
- b. Adjust links if necessary by rotating barrel until links are impending tension. Care should be exercised to prevent links from being over-tightened. Lock adjustment with 7-49064 nut. See Figure 4-6.

4-11. CHECKOUT AND ADJUSTMENT OF CENTERLINES OF 7-49021 SUPPORT PINS

- a. Verify that distance in a horizontal plane between centerline of 7-49021 support pins & vertical load cell centerlines is  $84.00 \pm 0.06$  inches. See Figure 4-1A.
- b. Adjust distance, if necessary, by varying number of 7-49058 shims used on each side of arm pivot bearings. See Figure 4-9. (Refer to Drawing 7-49002 for additional adjustment instructions.)
- c. Verify that distance between centerlines of 7-49021 support pins and horizontal base plane established between the upper faces of the 7-49008 caps of the 7-49005 auxiliary supports is  $18.00 \pm 0.03$  inches. See Fig. 4-1B. If this distance is not as specified, perform Step (d) or (e) for applicable site.

## SECTION IV

- 4-11. d. At AMR sites 11, 12, 13, & 14, adjust height of release arm as follows:  
See Figure 4-8.
- (1) Loosen 7-89206 nut on 7-89369 fitting of 7-89366 release cylinder sufficiently to free 7-89207 washer.
  - (2) Rotate 7-89372 piston rod by using a strap wrench around the 8.00-inch-diameter portion of rod. Rotation of rod clockwise as viewed from above will lengthen cylinder.
  - (3) When 18.00 inch dimension has been obtained, lock rod by tightening 7-89206 nut against 7-89207 washer and 7-89372 rod. Secure nut with a lockwire.
- e. At static test sites, adjust height of release arm as follows: See Figure 4-7.
- (1) With 7-49018 arm assembly supported by 7-49070 static firing links, remove NAS 464-14 bolt through 7-49196 nut of 7-49197 missile release arm support link.
  - (2) Remove 7-49071 lock pins from lower end of each 7-49070 static firing link by removing AN380 cotter pin.
  - (3) Using bars through holes provided in 7-49070 static firing links, rotate barrel portion of each link on one arm assembly simultaneously to obtain the 18.00 inch dimension. Rotation of barrel clockwise as viewed from above will shorten links.

NOTE

Care must be exercised in making this adjustment so that the arm assembly is not twisted by unequal adjustment of the links.

- (4) When desired adjustment is attained, lock each 7-49070 link with 7-49071 lock pin, rotating both link assemblies in same direction to align lock pin holes in link body with castellations in 7-49069 eye bolt. Insert cotter pins in each 7-49071 lock pin.
  - (5) Rotate 7-49196 adjusting nut on each 7-49197 link assembly until NAS 464-14 bolt can be inserted in holes in 7-49196 nut and 7-49194 eye. Secure bolt with nut. Apply a spot torque paint to 7-49196 adjusting nut and body of link.
- 4-12. CHECKOUT AND ADJUSTMENT OF 7-49006 AUXILIARY SUPPORT PINS.
- a1 Verify that distance between centerline of 7-49006 auxiliary support pins and centerline of Z load cells is 60.56 inches measured parallel to Y axis in a horizontal plane.
  - b. Adjust distance if necessary by varying number of washers used on either side of auxiliary support pivot bearings. (See drawing 7-49002 for additional adjustment instructions.) See figure 4-10.

## SECTION IV

4-13. CHECKOUT AND ADJUSTMENT OF 7-49276 SNUBBERS (AMR SITES ONLY)

- a. Verify that the distance from the end of the 7-49271 rod end (in the extended position), perpendicular to the centerline of the 7-49018 arm and mechanism assembly pivot pins is 42.3 inches with the 7-49271 rod end centerline lying in the plane of the Y-Y axis of the launcher. See Figure 4-11.

If this distance is not as specified adjust as follows:

1. Loosen AN 316-16R nuts which lock 7-49280 rod ends to 7-49281 brace rods.
  2. Rotate 7-49281 brace rods, using an open end or adjustable wrench on flats provided, until desired dimension is obtained.
  3. Tighten AN 316-16R nuts against 7-49280 rod ends to lock adjustment.
- b. Repeat procedure specified in step (a) to checkout and adjust arm on opposite end of the launcher.

4-14. CHECKOUT AND ADJUSTMENT OF 7-49018 RELEASE MECHANISM (AMR SITES ONLY)

The checkout is to be performed by using the tower utility hoist. The tower must be rolled back approximately 10 ft. on to the transfer table. The tower wheels should be checked to prevent accidental movement. The tower utility hoist should be positioned toward the end of the tram rails at the front of the tower so that the utility hoist cable, when lowered, will be approximately on the centerline of the launcher.

- a. Exhaust all pressure from 7-89366 release cylinder and place control valve in BY-PASS position.
- b. Remove the two 27-49082 springs and the 27-49083 lug from the 27-49085 strut assembly.
- c. Install release mechanism test fixture (7-49234) on one 7-49018 arm assembly, using the following procedure:
  1. Place 7-49237 beam assembly under 7-49018 arm assembly with 27-49084 strut in position over block on 27-49316 shaft and attach with AN-7 bolt. See Figure 4-4.
  2. Install 7-49238-41 sub-assembly on 7-49009 missile support arm static-firing link lugs, using 7-49250 bushings, 7-49249 washers and AN16 bolts.

3. Bolt 7-49238-37 and -38 sub-assemblies to 7-49009 launcher arm using 7-49245 studs and AN365-820 nuts to attach 7-49238-9 and -10 members.
4. Bolt 7-49238-37 and -38 subassemblies to -41 subassembly using AN8 bolts.
5. Attach 7-49238-39 and -40 subassemblies to -37 and -38 subassemblies with AN8 bolts and to 7-49239 pins through launcher arm pivot points by means of 7-49247 collars and AN6 bolts.
6. Attach 7-49237 beam assembly to 7-49238 tripod assembly with AN8 bolts.
7. Make sure 7-49021 missile support pin is fully extended from 7-49018 arm and mechanism assembly by noting that 7-49042 links are locked against -69 stop on top of 7-49099 arm assembly. Remove shear wire from 7-49042 links and 7-49038 eye. See Figure 4-5.
8. Attach 7-49244 sling to end of 7-49237 beam by means of 97-99102-003 shackle.

Note

The 7-49244 sling incorporates an aluminum shear bolt which is designed to fail if the load required to actuate the mechanism or rotate the arm exceeds the maximum permissible. Failure of shear bolt indicates binding in the mechanism due to corrosion or improper set up. Corrective action should be taken. Under no circumstances should a steel bolt be substituted for the aluminum shear bolt.

CAUTION

In the following operations, the slowest hoist speed should be used.

- d. Place 27-49753 checkout fixture in position against 7-49009-85 stop on the launcher arm structure. Raise hoist slowly until 7-49019 lever contacts 27-49753 checkout fixture. STOP HOIST. (See Figure 4-18). With fixture in this position, arm mechanism should have moved such that motion of 7-49021 missile support pin into 7-49018 arm and mechanism assembly is impending (that is, any additional movement of arm will begin pin motion and retraction). The 7-49042 links should have moved above the overcenter locked position.
- e. Press down on the 7-49042 links until they are in contact with the rollers on the 7-49049 bellcranks and the 7-49049 bellcranks are in contact with the lugs on the 7-49028 links. With the links in this position, the bolts in the 7-49046 levers should be just contacting the bottom of the slots in the 7-49028 links.

Note

To insure that the bolts in the 7-49046 levers are in contact with the bottom of the slots in the 7-49028 links, remove all slack from the mechanism by pushing against the 7-49022 arms in the direction of extending the 7-49021 support pin.

- f. With the mechanism in this position, verify that the 7-49042 links have been raised a minimum distance of 0.50 inches above the overcenter locked position. See Figure 4-14.

NOTE

If all conditions stated in steps (e) & (f) do not exist, use the following procedure to adjust the mechanism. Otherwise, proceed to step (g).

- (1) Remove the cotter pin through the 7-49039 barrel at the top of the 7-49018 arm & mechanism assembly.
- (2) Rotate the 7-49039 barrel in a clockwise direction (as viewed from the pivot end of the launcher) while pressing down on the 7-49042 links until the 7-49042 links are bearing on the rollers on the 7-49049 bellcranks, and the 7-49049 bellcranks are bearing on the lugs on the 7-49028 links and the bolts through the ends of the 7-49046 levers contact the bottom of the slots in the 7-49028 links. If this position is passed, readjust by rotating the 7-49039 barrel in a counter clockwise direction keeping the 7-49042 links in bearing with the rollers on the 7-49049 bellcranks.

NOTE

To insure that the bolts in the 7-49046 levers are in contact with the bottom of the slots in the 7-49028 links, remove all slack from the mechanism by pushing against the 7-49022 arms in the direction of extending the 7-49021 support pin.

- (3) With the mechanism in this position again verify that the 7-49042 links have been raised a minimum distance of 0.50 inches above the overcenter locked position.
- g. Remove the 27-49753 checkout fixture.
- h. Observe that a minimum of 0.19 inches clearance exists between the 7-49042 links and the 7-49039 barrel. Check by sliding a 0.19 feeler gauge across the open end of the 7-49039 barrel while moving the 7-49042 links through full vertical travel from the overcenter locked position. See Figure 4-14. If check is successful, proceed to Step h (9). If check is not successful, adjust as follows:
- (1) Determine minimum clearance between end of 7-49042 link and 7-49039 barrel. Note difference between existing minimum clearance and required minimum clearance of 0.19 inches.
  - (2) Remove Q320-24-A97 bolt and 52TE-242 nut attaching 7-49042 link to 7-49038 eye. Measure the distance between the centerline of the 7-49038 bolt hole and the centerline of bolt in 7-49040 eye.
  - (3) Rotate 7-49039 barrel to screw it toward the 7-49040 eye a distance required to obtain 0.19 inches minimum clearance as noted in Step (1).
  - (4) Insert cotter pin in 7-49039 barrel.

NOTE

If barrel has moved sufficiently to cover pre-drilled hole in 7-49040 eye, drill 0.203 to 0.208 hole through 7-49039 barrel and 7-49040 eye, as required, to permit insertion of cotter pin.

## 4-14. (continued)

- (5) Unscrew 7-49038 eye sufficient to re-establish the distance between the centerline of bolt hole in 7-49038 eye and centerline of bolt in 7-49040 eye as established in step (2).
- (6) Insert Q320-24-A97 bolt in 7-49042 link and 7-49038 eye.

NOTE

If 7-49023-11 bushing and Q8-H5068-2P washer in 7-49038 eye have been disturbed during previous steps, reinstall before inserting bolt.

- (7) Attach 52TE-242 Nut to Q320-24-A97 bolt.
- (8) Verify 0.19 inches minimum clearance using the procedure specified in Step (h).

NOTE

Repeat steps 4-14d through g.

- (9) Insert cotter pin in 7-49039 barrel unless inserted in step (4).
- i. Retract the 7-49021 support pin by rotating the 7-49019 levers toward the 7-49009 arm structure until the 7-49019 levers contact the 7-49009-85 stops on the launcher arm structure. STOP HOIST (See Figure 4-15).
- j. Verify that 7-49027 uplocks are now engaged with bolts in end of 7-49019 levers. If they are not, adjust as follows:
  1. Center 7-49027 uplocks in slots in 7-49019 levers by shimming uplock in desired direction, using Q-8H-5212 washers on pivot bolt. See Fig. 4-12.
  2. Extend uplock to engage bolt through 7-49019 lever by placing not more than one additional AN960 washer on each bolt between 7-49009-31 plate on arm structure and 7-49020 fitting.
- k. Release the 7-49027 uplocks, lower hoist, extend 7-49021 pin, place 7-49042 links against 7-49009-69 stop, and insert AN995-AA91 shear wire through 7-49042 links and 7-49038 eye.
- l. Actuate hoist until 7-49021 pin is fully retracted and 7-49019 levers have contacted 7-49009-85 stops. With the hoist in this position, verify that there is a minimum clearance of 0.12 inches between the 7-49022 arms and 7-49009-57 plate on arm structure. Using a pry bar, remove excess slack in linkage by applying a force against 7-49022 arms in the direction extending 7-49021 pin prior to checking clearance. See Figure 4-15. The 7-49019 levers must be in contact with the 7-49009-85 stops on the launcher arm structure while performing this step.
- m. Continue raising 7-49018 launcher release arm assembly until the locking segment slots on the piston rod of the 7-89366 holddown and release cylinder are fully exposed. STOP HOIST.

n. Check condition of shaft surface, keyway and segment slots for scuffing, gaul marks and corrosion. Lubricate exposed surfaces.

o. Activate hoist to lower launcher arm to the starting position.

p. Remove 7-49034 checkout fixture.

#### 4-15 CHECKOUT AND ADJUSTMENT OF 7-49021 SUPPORT PINS.

a. Set the distance from the shoulder of one 7-49021 missile support pin to the centerline of the 7-49006 auxiliary support pins to  $61.46 \pm .03$  inches. Use the procedure specified in steps (c) through (e) below. See Fig. 4-1A.

b. Set the distance between the shoulders of the two 7-49021 missile support pins to  $122.92 \pm .03$  inches. Use the procedures specified in steps (c) through (e) below in adjusting the pin on the other side to the one set in the preceding step.

c. Remove lock wire and AN4 bolts (2) holding 7-49047 lock to bottom of 7-49045 trunnion block. See Figure 4-16.

d. Use a spanner wrench to rotate 7-49044 nut until desired dimension is obtained.

e. Reinstall 7-49047 lock, rotating nut if necessary to align slot with blade of lock. Secure the bolts with safety wire.

f. Again verify with the 7-49021 support pins fully retracted that there is a minimum clearance of 0.12 inches between the 7-49022 arms and the 7-49009-57 plate on the launcher arm structure. Using a pry bar, remove all slack from the mechanism by pushing against the 7-49022 arms in the direction of extending the 7-49021 support pin prior to checking the clearance. The 7-49019 levers must be in contact with the 7-49009-85 stops on the launcher arm structure while performing this step (See Figure 4-15).

#### Note

Do not adjust the 7-49021 pin dimensionally by rotating the 7-49039 barrel. Such rotation will change the timing of the mechanism.

#### 4-16 CHECKOUT AND ADJUSTMENT OF 7-49005 AUXILIARY SUPPORTS (AMR SITES ONLY).

a. Allow 7-49005 auxiliary supports to rotate to retracted position.

b. Place a protractor level on flat machined area at top and measure angle of inclination. Angle should be 30 degrees  $\pm$  6 degrees.

c. Adjust length of 7-08247 cylinders to obtain proper angle:

(1) Loosen NAS 509 locknut until NAS513 lockwasher is free of slots in piston rod. See Figure 4-17.

(2) Turn piston rod with a strap wrench around piston rod immediately adjacent to rod end.

(3) When desired adjustment is attained, lock rod end to piston rod by tightening NAS 509 nut, making certain NAS 513 washer is engaged in slots on piston rod.

**4-17. CHECKOUT AND ADJUSTMENT OF SERVICE LINE COUPLING SUPPORT ASSEMBLIES**

- a. Verify that distance between centerlines of 7-49021 support pins and upper face of 27-49019 launcher rise-off disconnect panel assembly is 80.64 ~~80.03~~ inches. (See Figure 4-1B).

If this distance is not as specified, adjust height of the 27-49021 launcher rise-off disconnect panel as follows: (See Figure 5-4).

1. Remove lockwire from 27-49030-9 forks and 27-49030-13 barrels.
  2. Rotate 27-49030 barrel until the desired dimension is obtained.
  3. Secure the 27-49030-9 forks and 27-49030-13 barrels with lockwire.
- b. Repeat the procedure specified in 4-17a to checkout and adjust disconnect panel located on the opposite side of launcher.
- c. Check support links for freedom of motion and proper range of travel.

**4-18. PRE OPERATION CHECKOUT OF 7-49005 AUXILIARY SUPPORTS (AMR SITES ONLY)**

- a. Use procedure specified in ZM-7-516(TN) to actuate 7-49005 auxiliary supports through their full travel.
- b. Check for clearance between auxiliary support and other portions of launcher.
- c. Check action of flex lines for any tendency to bind or chafe.

**4-19. PRE-MATING PREPARATION OF LAUNCHER**

- a. Engage trunnion shafts in launcher. The load cells may need to be readjusted to permit trunnion shafts to enter launcher easily.
- b. Prepare launcher for rotation to horizontal position and disconnect seven load cells from launcher. Refer to ZM-7-200E(TN) for rotating procedures.
- c. Rotate launcher to a horizontal position and check for possible interference between launcher and erection equipment. Flex hoses and lines should be checked for any tendency to bind or chafe. With launcher in horizontal position, centerline of 7-49021 support pins should be approximately 100 inches above ramp.
- d. Install 7-95095 arm retractor assemblies on erector and launcher.
- e. Swing open 7-49018 arm and mechanism assemblies with 7-95095 retractor assemblies.
- f. Unlock toggles at top of 7-49018 arm assembly by removing shear wire through 7-49042 links and 7-49038 eye, by raising 7-49042 links from 7-49009-69 stop and manually retract 7-49021 support pin.
- g. Fold 27-49085 strut assys back against 7-89366 cylinders so that every portion of assembly will be at least 98 inches from centerline of launcher.
- h. If missile is not to be mated to launcher at this time, close 7-49018 arm assemblies. Rotate launcher back to vertical position and support it on load cells.

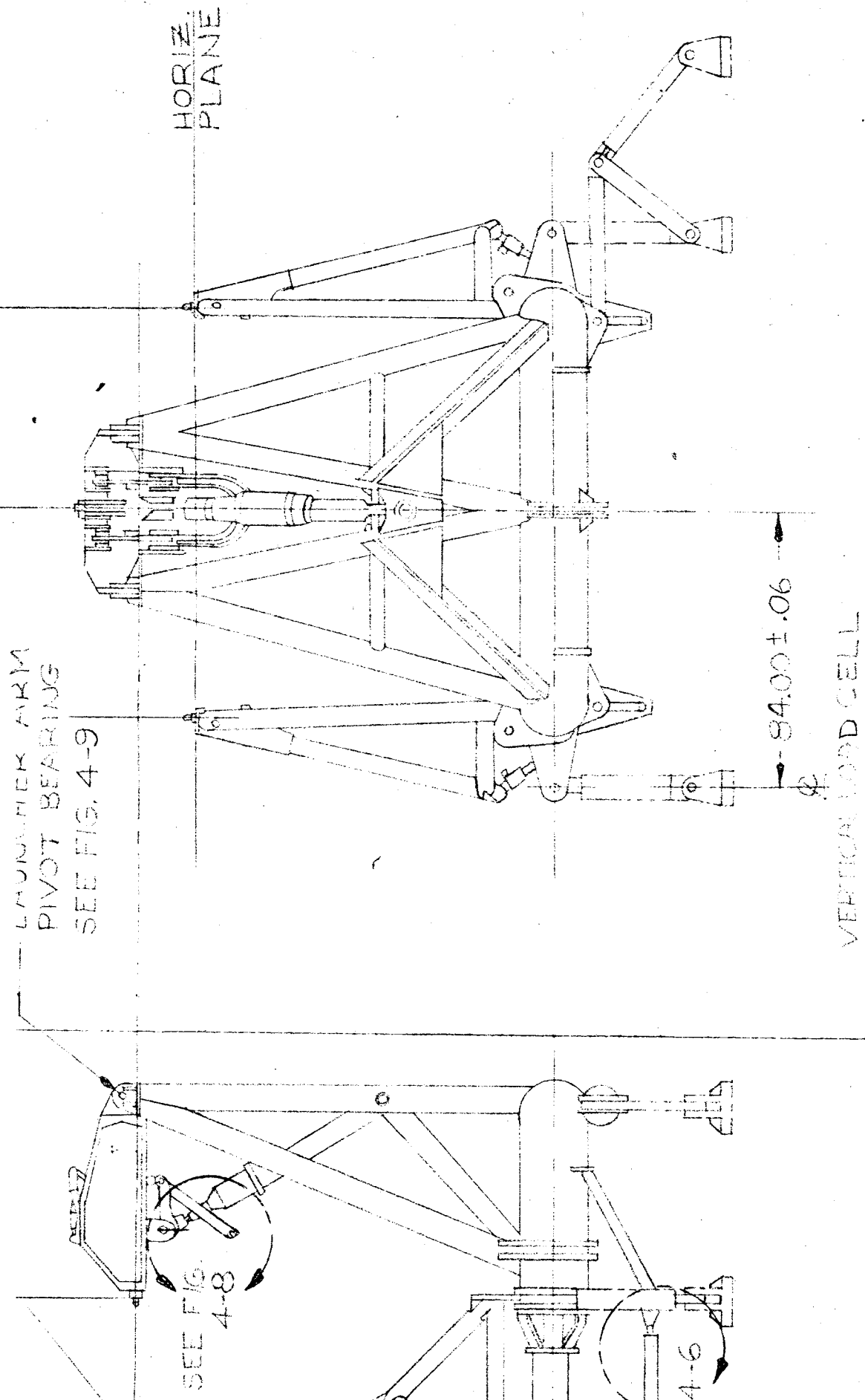

4-1A LAUNCHER RIGGING AND ADJUSTMENT

B

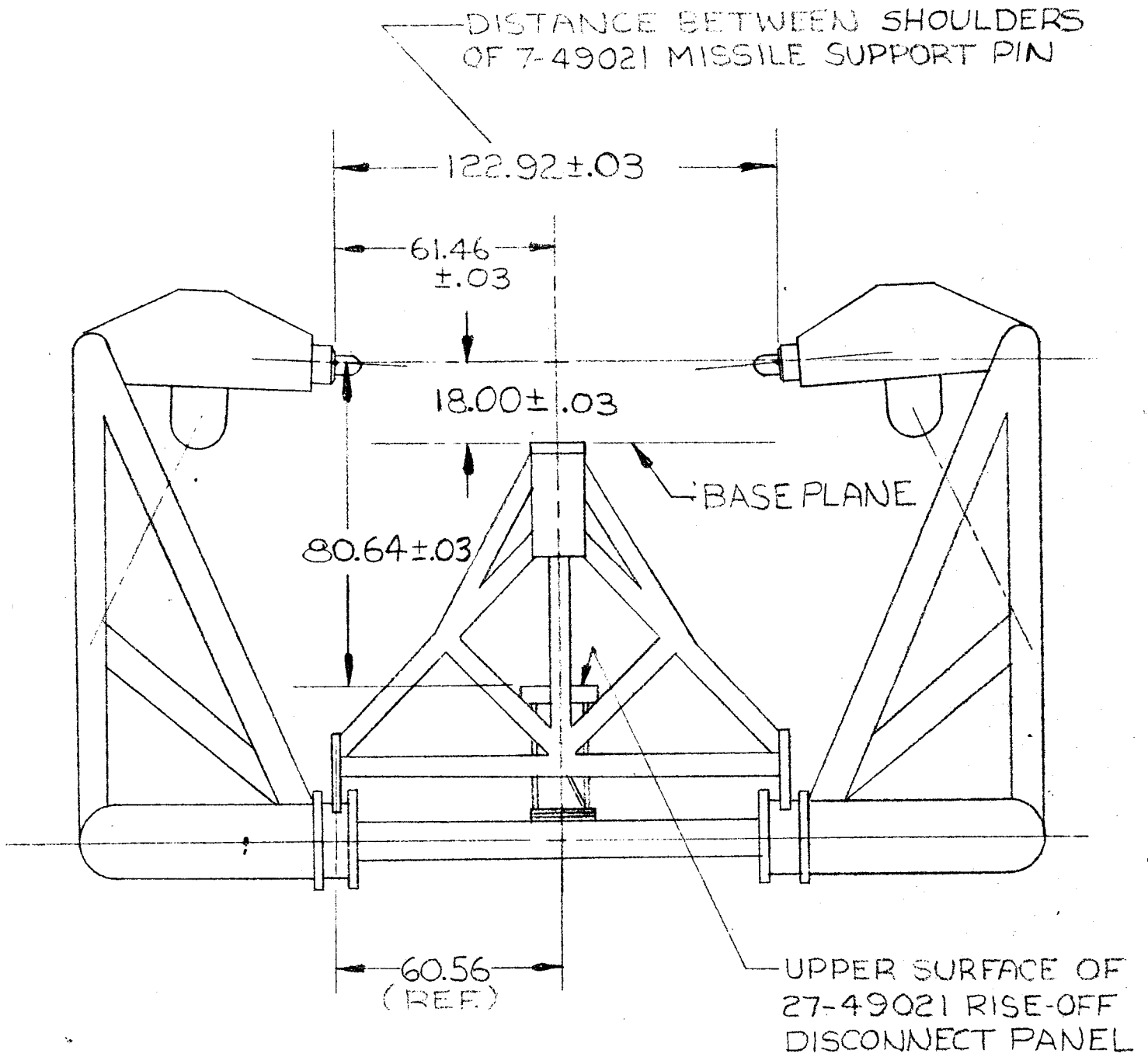

FIGURE 4-1B LAUNCHER ADJUSTMENT



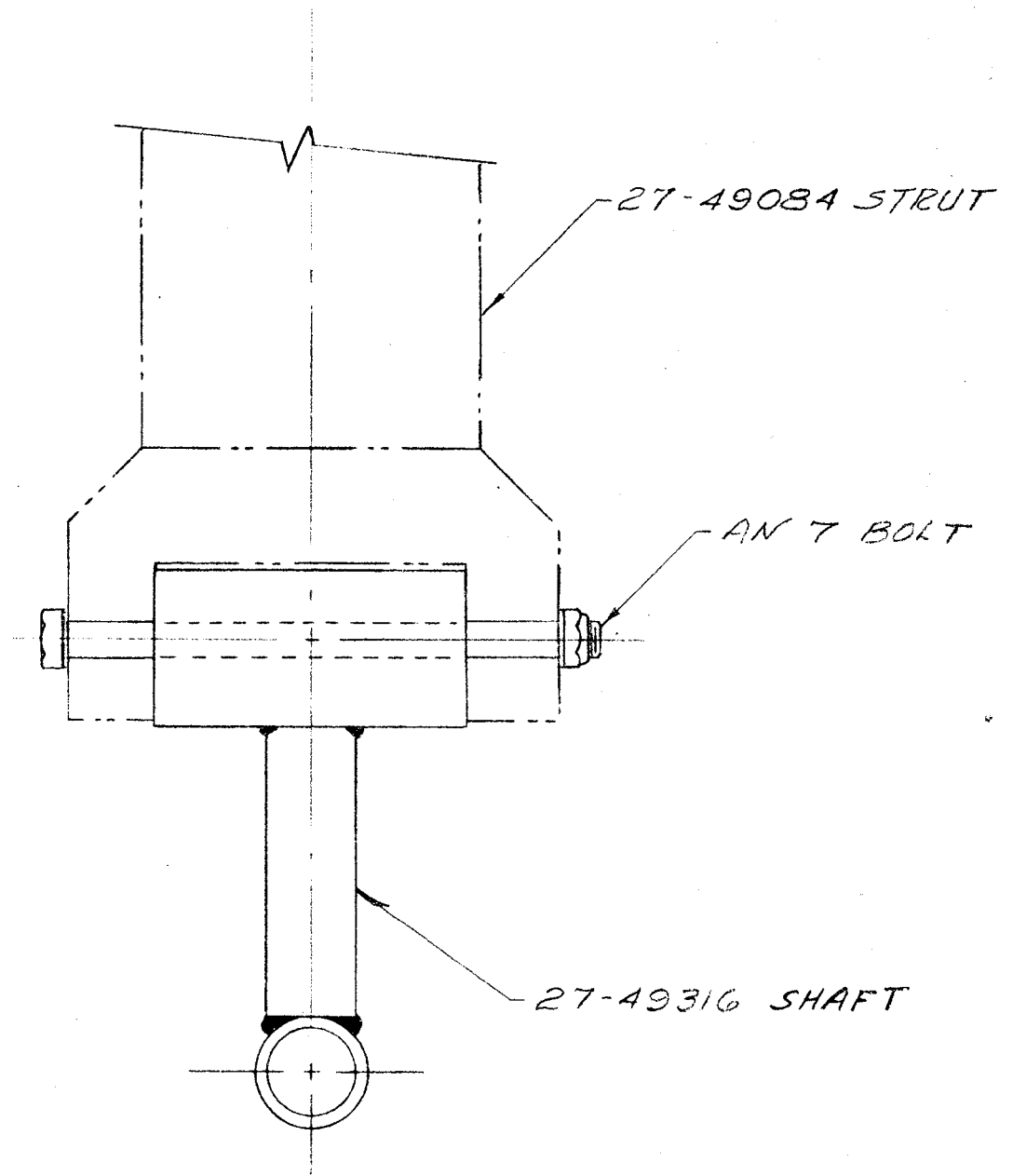
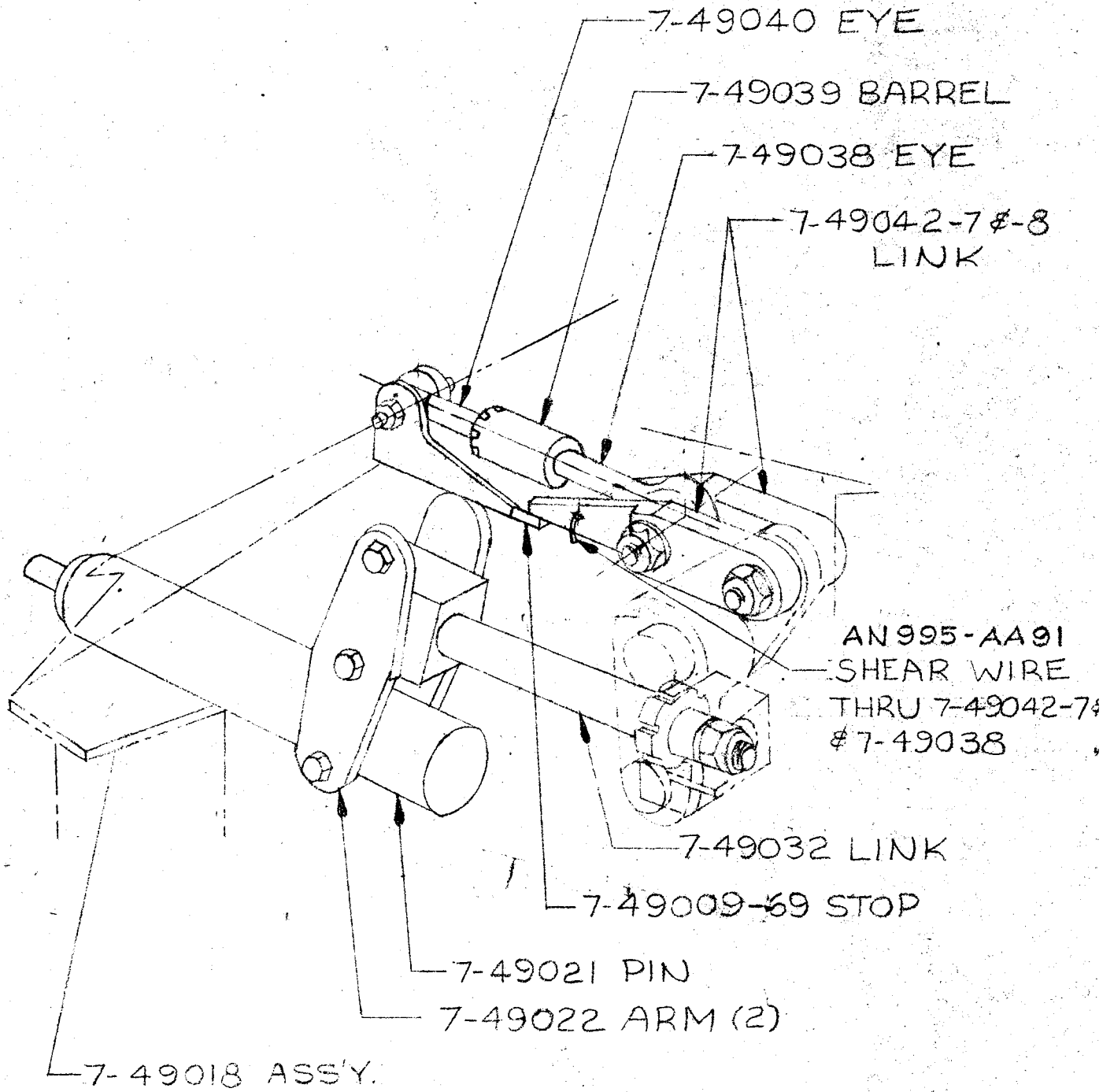

FIG. 4-4 27-49084 STRUT LOCKED  
IN POSITION IN CHECKOUT  
FIXTURE



MISSILE SUPPORT PIN SHOWN FULLY  
 EXTENDED FROM 7-49018 ARM & MECHANISM  
 ASSEMBLY

FIGURE 4-5

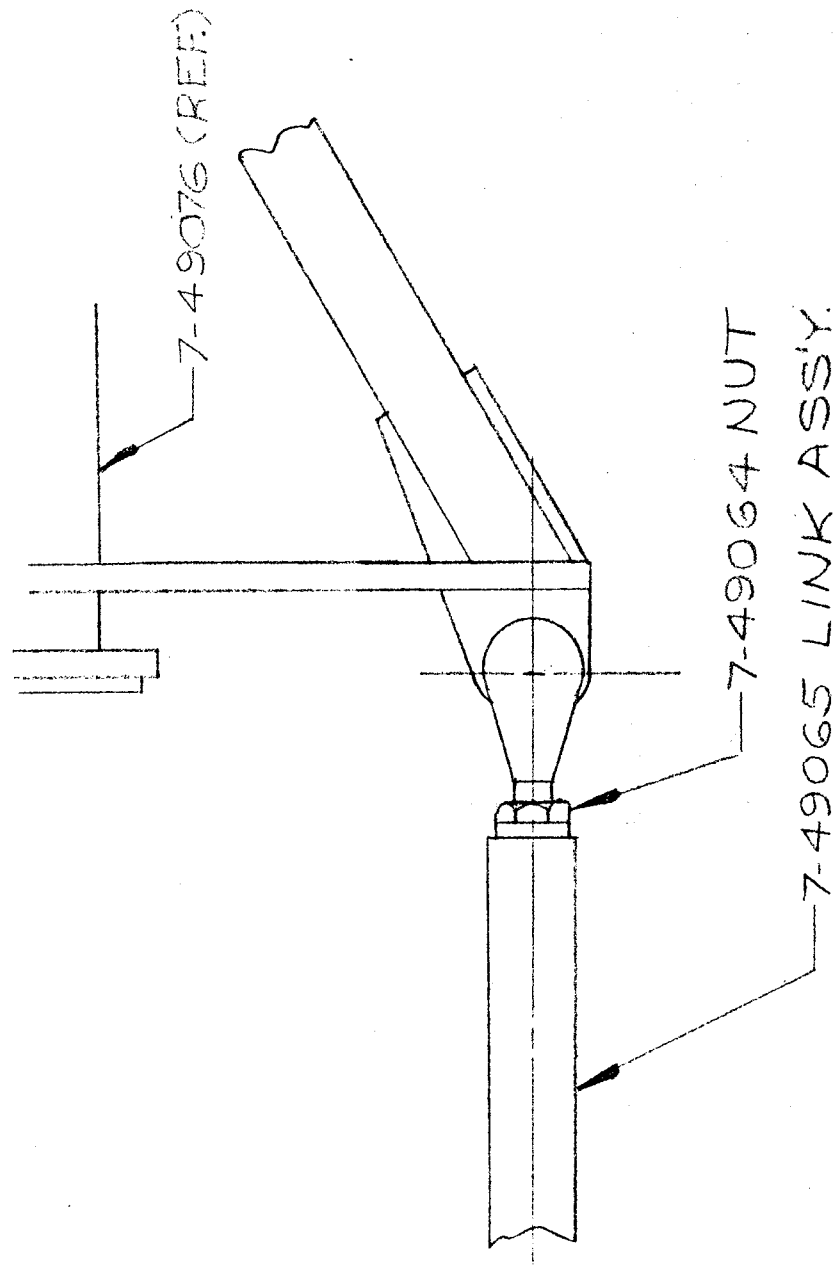

FIGURE 4-6 ADJUSTMENT OF 7-49065 LINKS

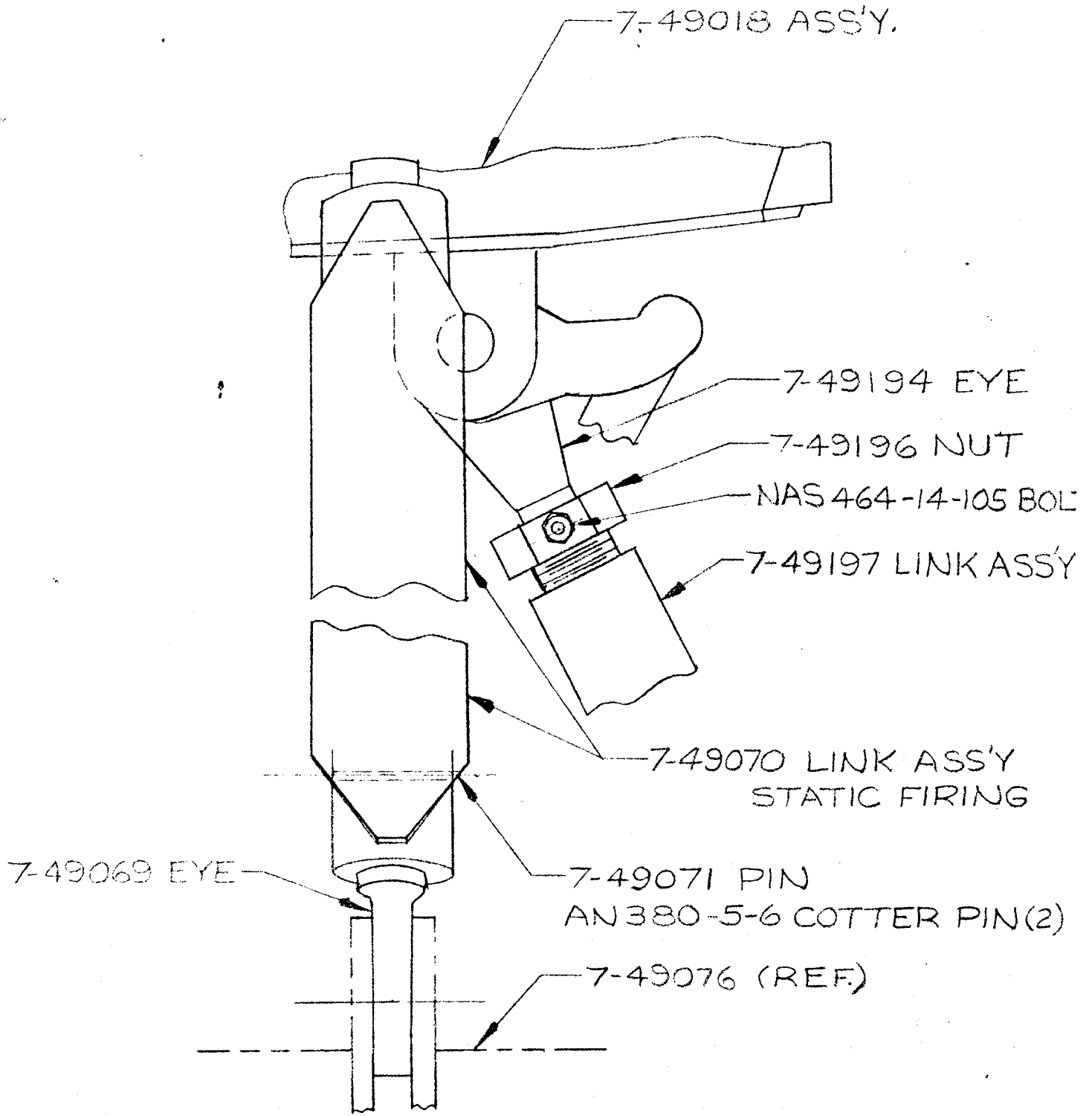

FIGURE 4-7 RELEASE ARM HEIGHT ADJUSTMENT  
AT STATIC TEST SITES

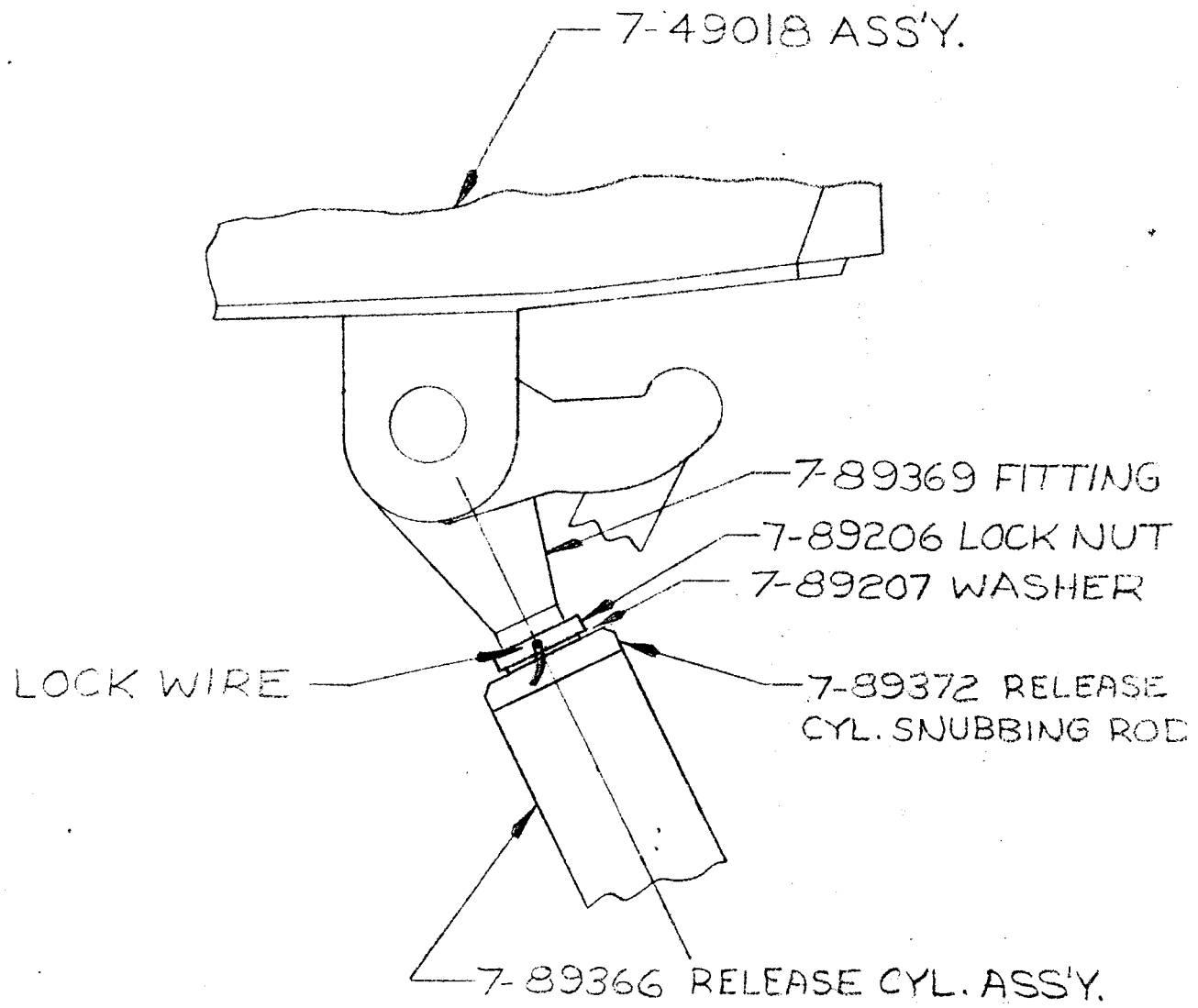

FIGURE 4-8 RELEASE ARM HEIGHT ADJUSTMENT AT AMR SITES 11, 12, 13 AND 14

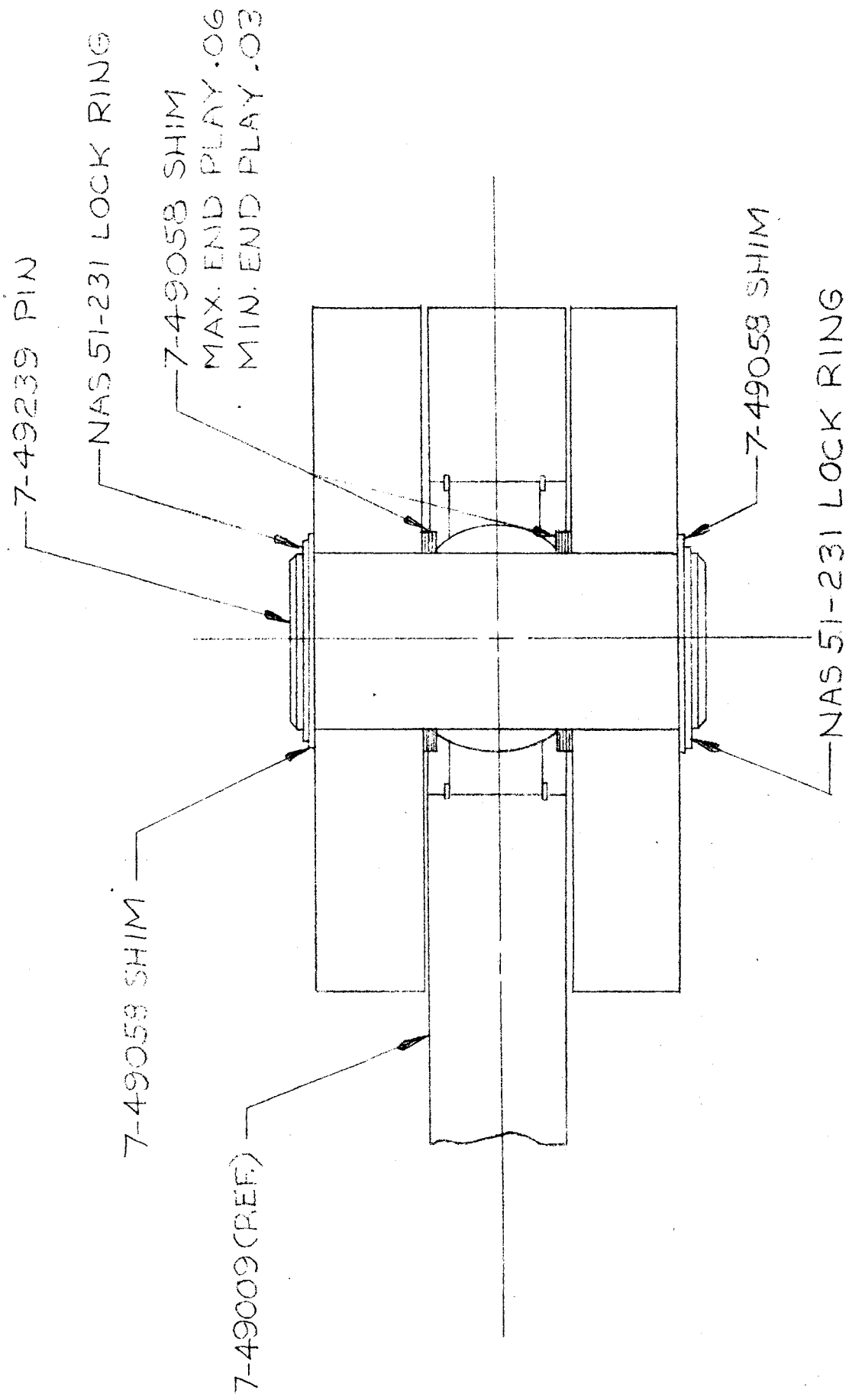
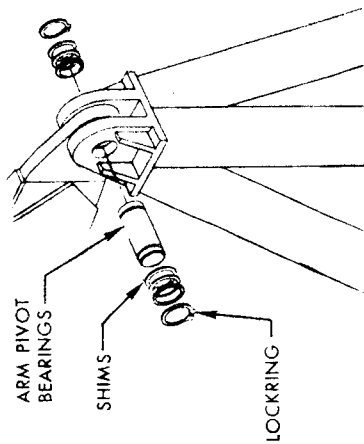

FIGURE 4-9 ADJUSTMENT OF DISTANCE IN A HORIZONTAL PLANE BETWEEN CENTER-LINE OF 7-49021 SUPPORT PINS AND VERTICAL LOAD CELL CENTERLINES



20348 U1

Figure 4-9A. MAINSUPPORT ARM PIVOT BEARING-EXPLODED VIEW

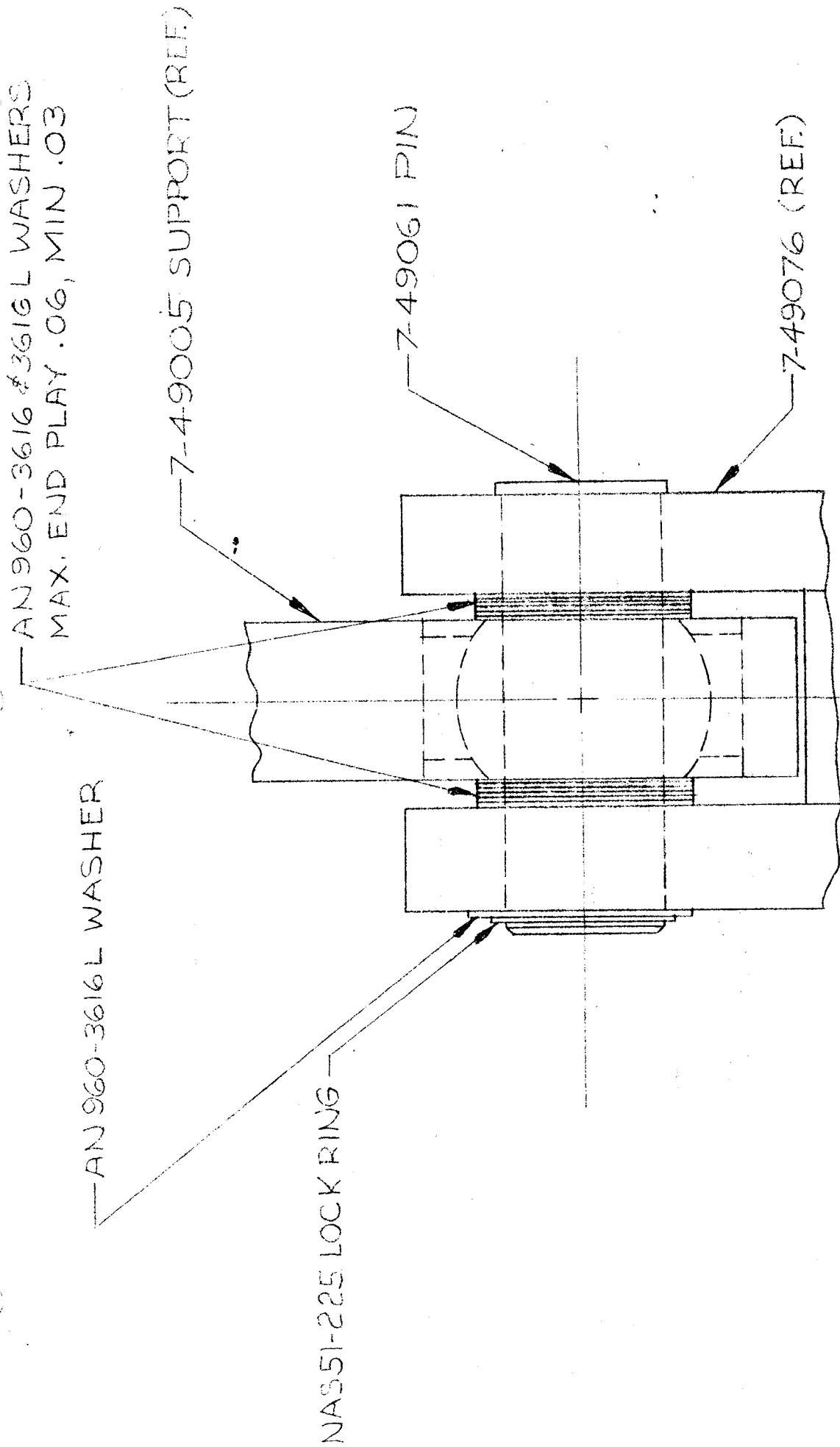
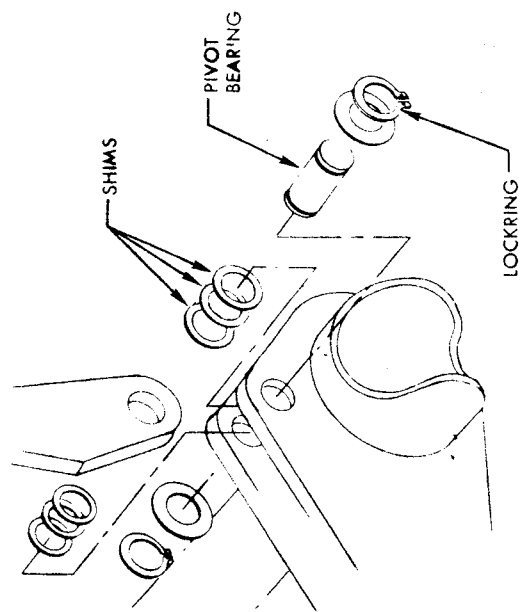

FIGURE 4-10, ADJUSTMENT OF DISTANCE BETWEEN CENTERLINE OF 7-49006 AUX. SUPPORT PINS AND CENTERLINE OF Z LOAD CELLS



20.34-910

**Figure 4-10A. AUXILIARY SUPPORT ADJUSTMENT-EXPLODED VIEW**

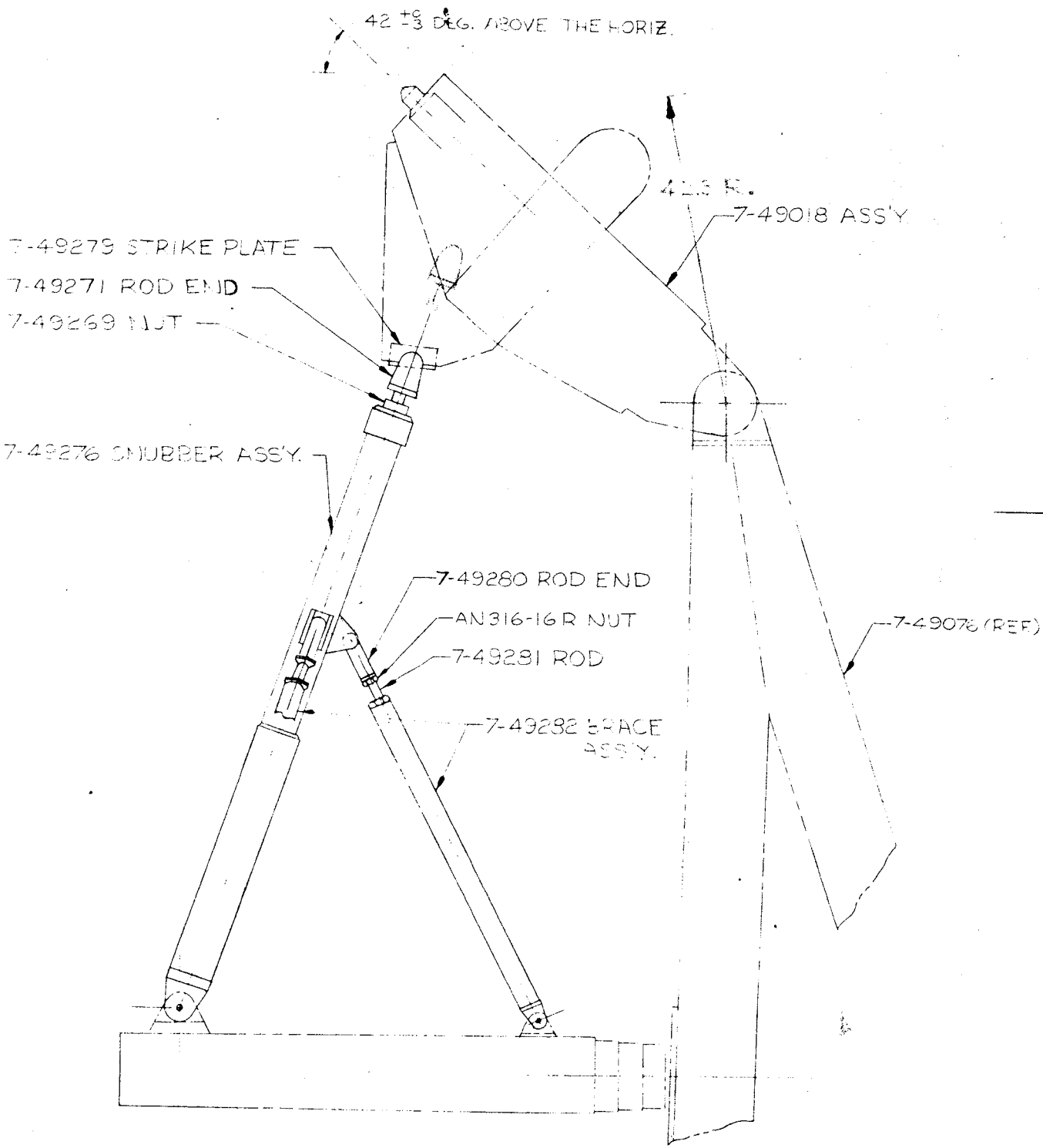

FIGURE 4-11 MISSILE SUPPORT ARM SHOWN ROTATED AND FULLY COMPRESSING SNUBBER

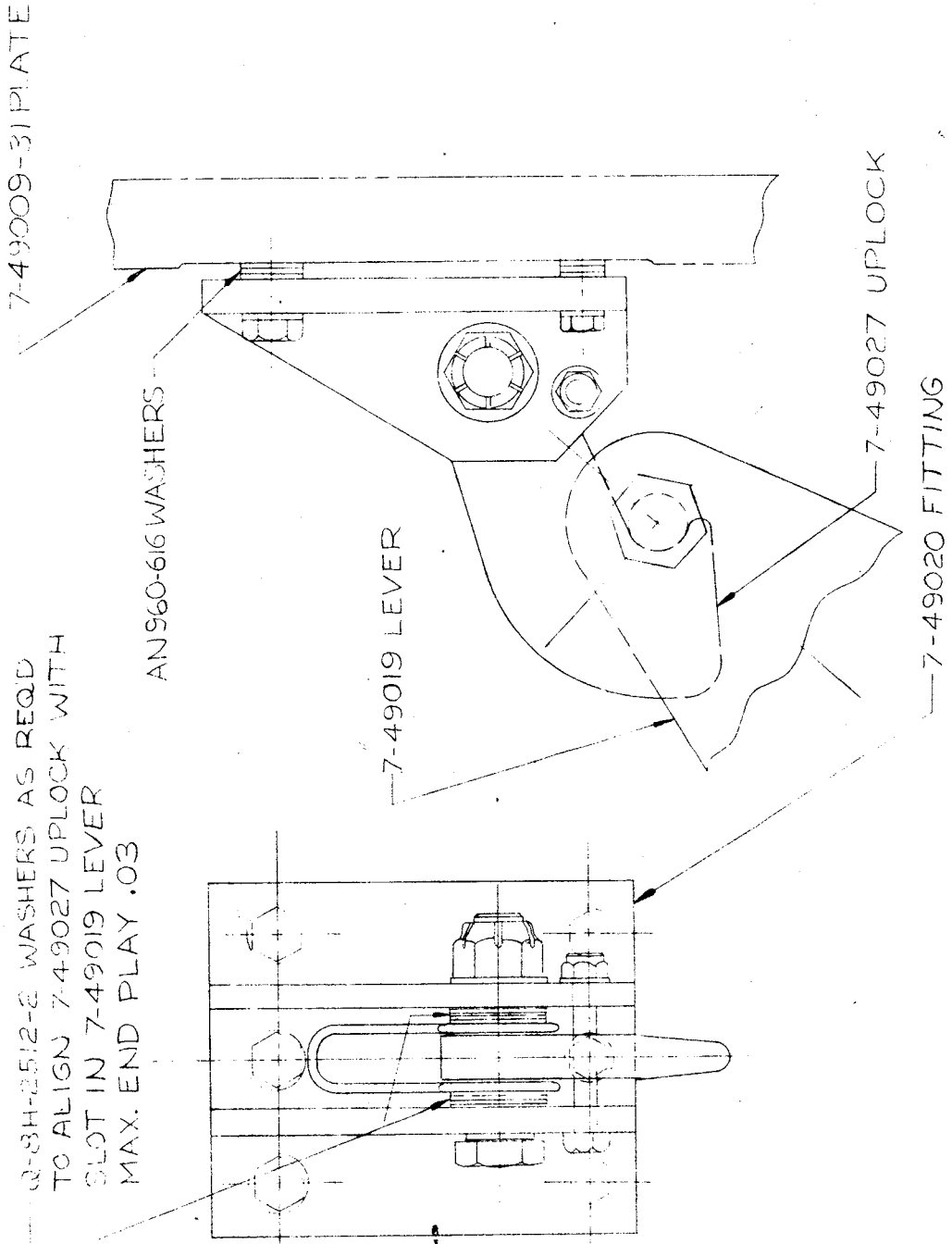

FIGURE 4-12 UPLOCK ADJUSTMENT



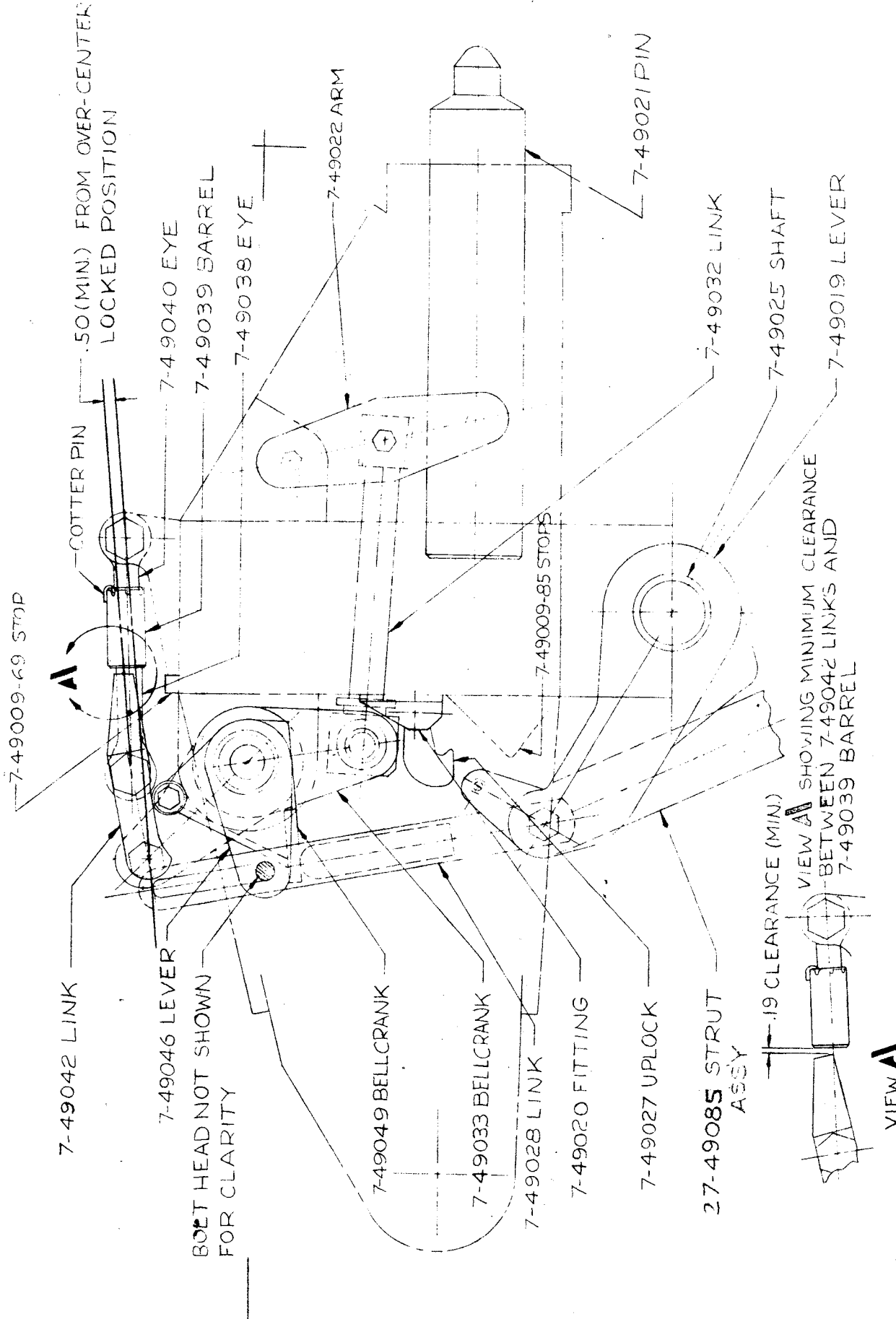

FIGURE 4-14 ARM MECHANISM ASSEMBLY - MISSILE SUPPORT PIN UNLOCKED IN EXTENDED POSITION

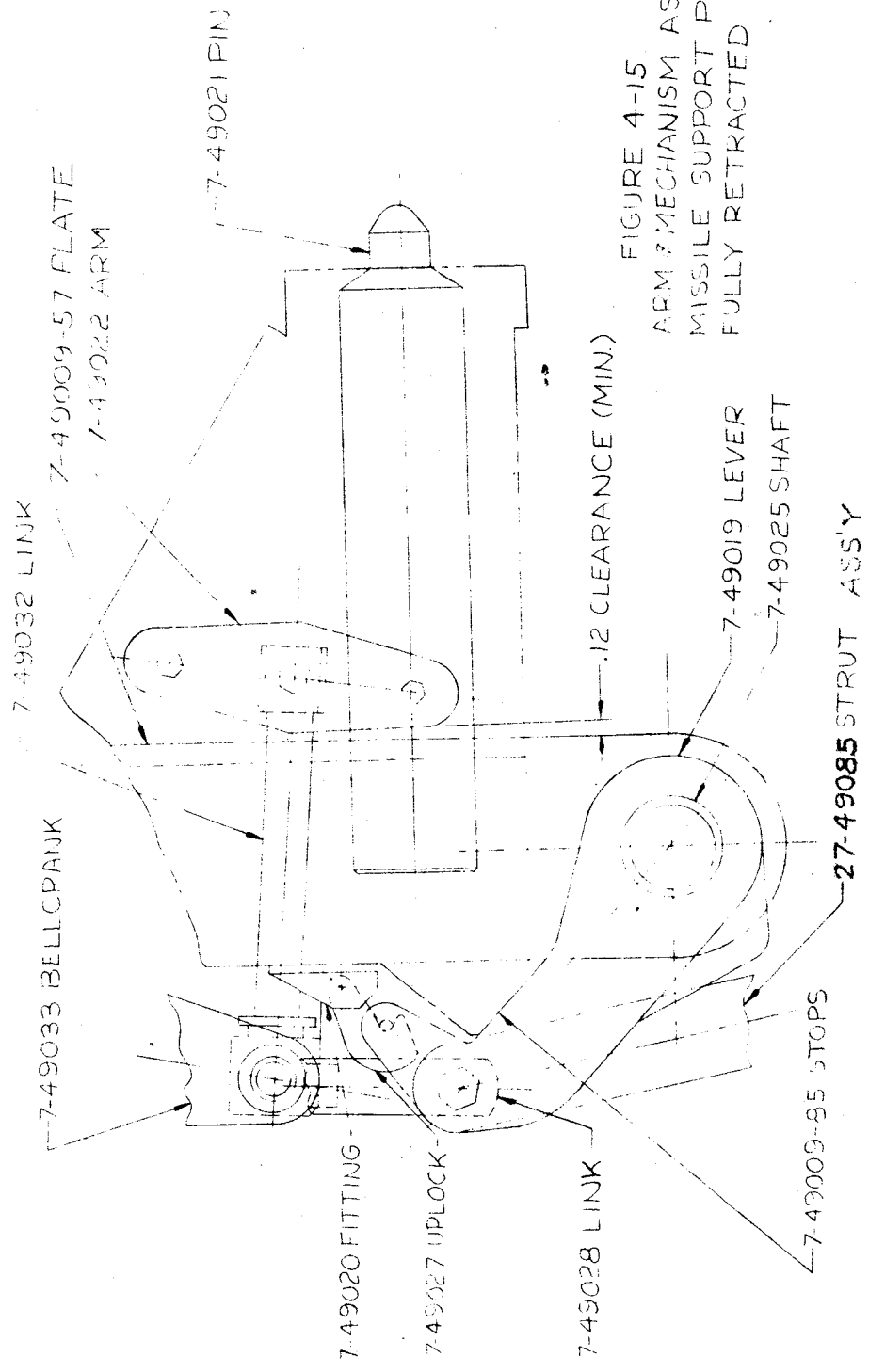

FIGURE 4-15.  
 ARM & MECHANISM ASS'Y.  
 MISSILE SUPPORT PIN  
 FULLY RETRACTED

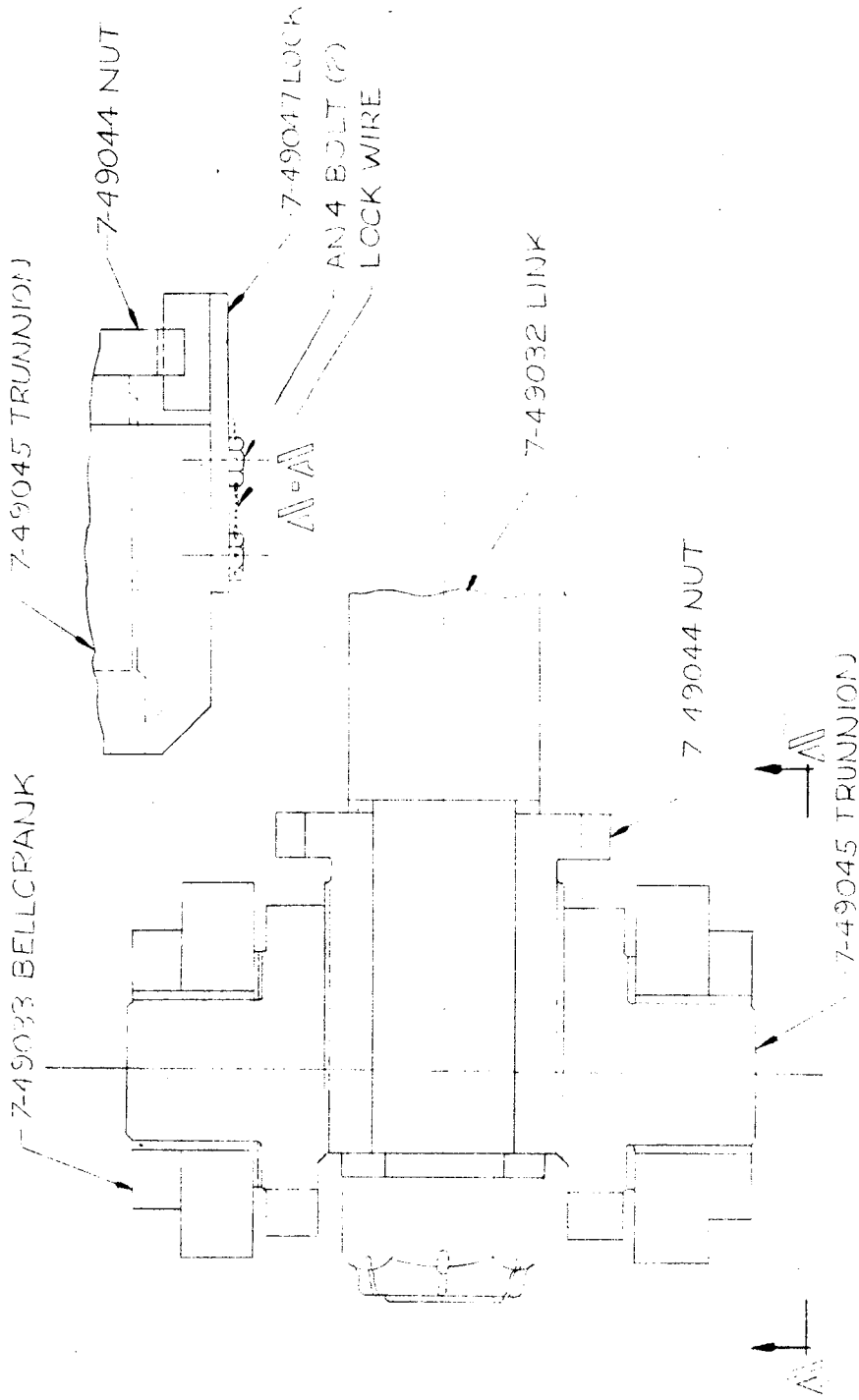

FIGURE 4-16 MISSILE SUPPORT PIN ADJUSTMENT

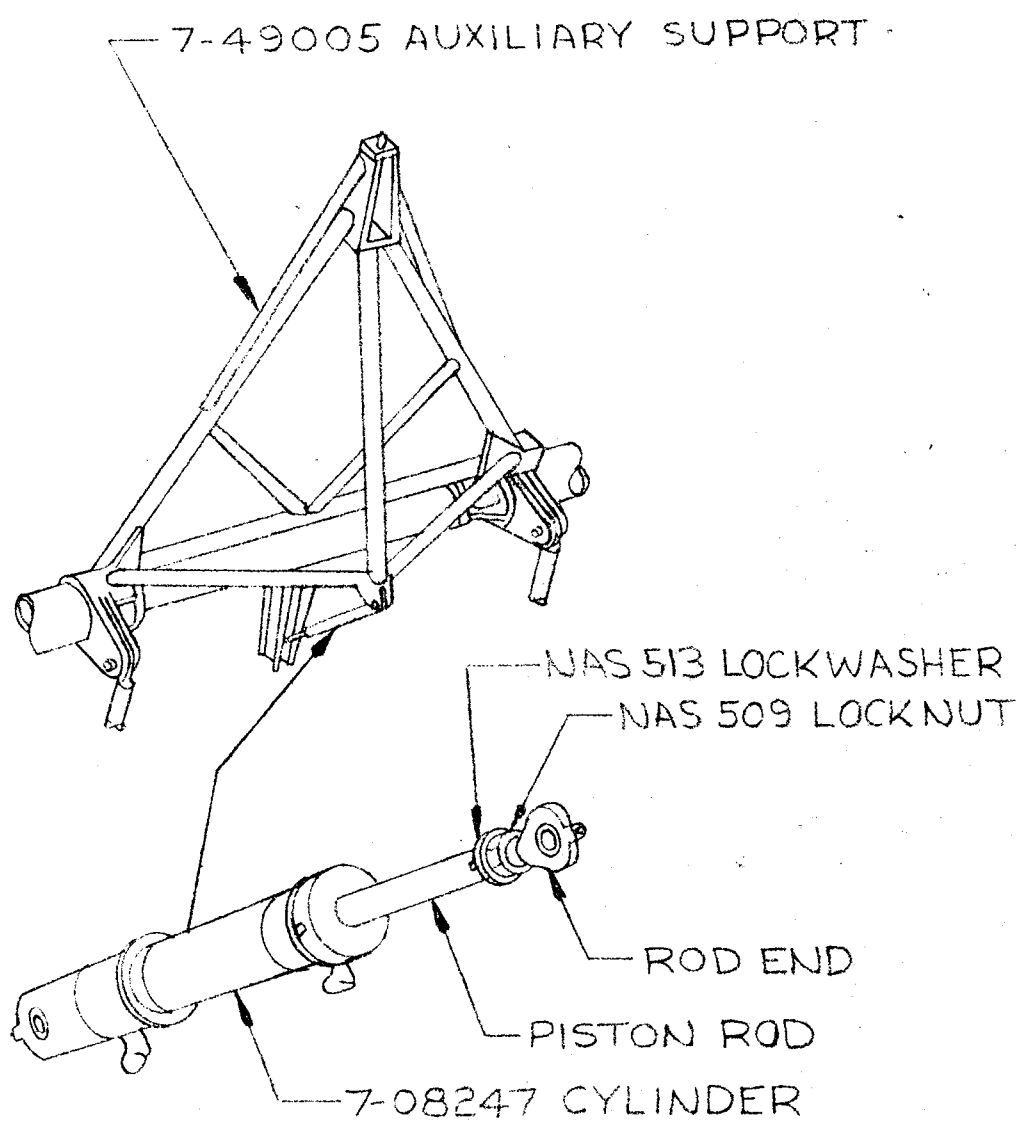

FIGURE 4-17 AUXILIARY SUPPORT ADJUSTMENT

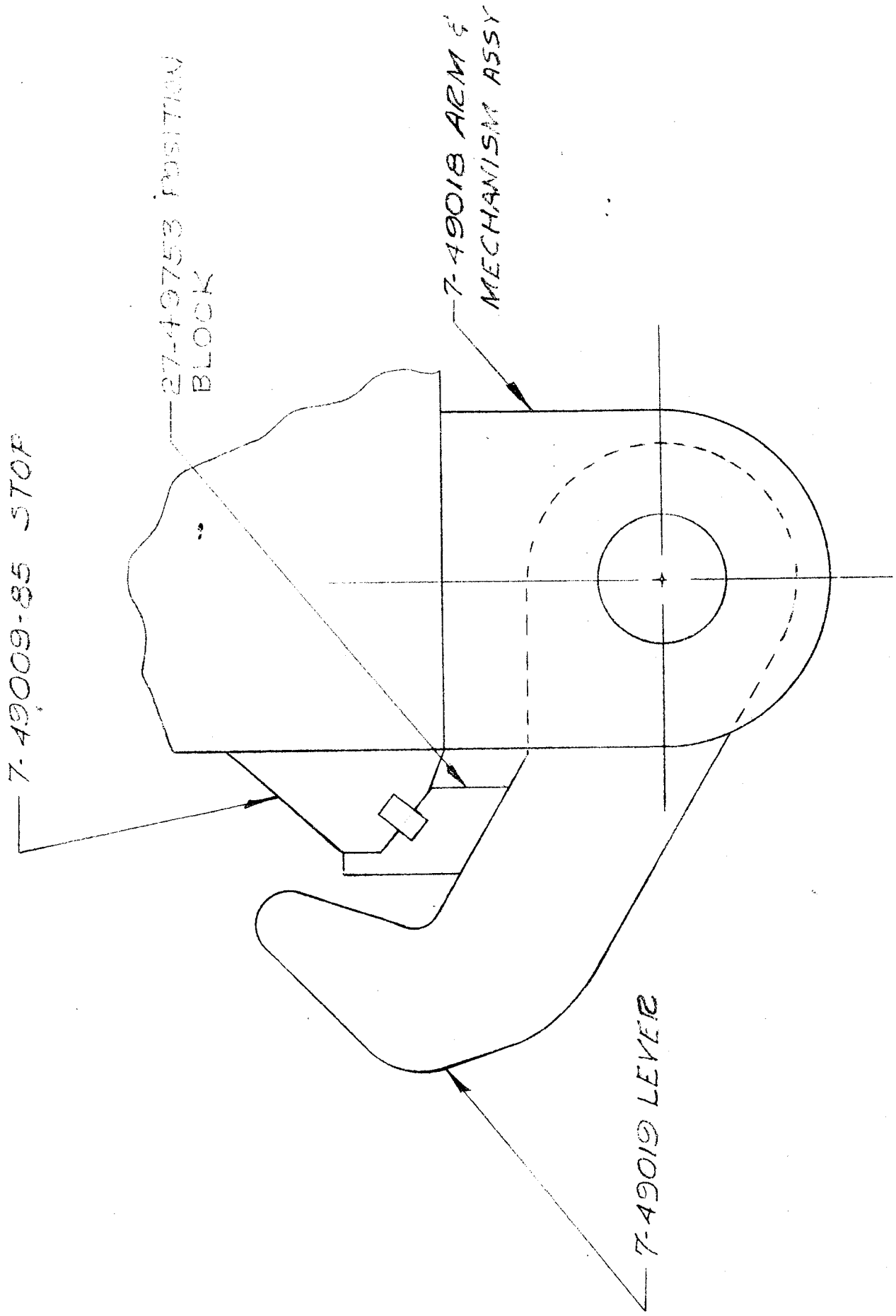

FIGURE 4-18 POSITION BLOCK INSTALLED ON  
7-49018 ARM & MECHANISM ASSY

## SECTION V

## OPERATION

5-1. OPERATING DETAILS.

- 5-2. Before the missile and the launcher are mated and erected, the launcher shall be adjusted as specified in Paragraphs 4-9 through 4-19.
- 5-3. The missile erection procedure is covered in ZM-7-200E(TN). The following procedures cover the steps which must be accomplished (1) before erection of the missile, (2) during erection of the missile, and (3) after erection of the missile on the launcher.

5-4. PROCEDURES DURING MATING OF MISSILE AND LAUNCHER.Note

From missile 23D & on the 27-04500 socket assembly will be used in place of the 7-09229 socket.

The 27-04500 socket assembly incorporates a locking plunger which prevents the socket bearing from rotating until the main support pin is inserted into the socket. As the pin is inserted, it compresses the plunger which unlocks the socket bearing.

WARNING

The socket cannot be rotated without compressing the plunger.

During mating of the missile and the launcher, the missile should be stopped about 2 inches short of mating position. The main support pins can then be inserted at that point without unlocking the sockets manually.

5-5. CONNECTING PROPELLANT FILL AND DRAIN VALVES.

- a. Stop rearward travel of trailer and missile approximately one foot from final position in launcher.
- b. Vent chambers between fill and drain valves and protective caps on airborne and ground fill and drain valves.
- c. Remove protective caps from each valve.
- d. Complete mating of missile to launcher.
- e. Connect ground and airborne, fuel and liquid-oxygen fill and drain valves by actuating quick-action latches.
- f. Remove pins and transport links connecting ground fill and drain adaptors to missile thrust barrel.

## SECTION V

5-6. PROCEDURE FOR CONNECTING RISE-OFF DISCONNECT FITTINGS.

- a. The launcher disconnect panels are fitted with guide pins which mate with corresponding bushings in the missile disconnect panel as the missile is backed into the launcher. Check guide pins to ensure proper entry into bushings in missile panel.
- b. As missile is backed farther into launcher, rise-off disconnect fittings will start to engage. The fittings must be checked to ensure that they engage without binding.

5-7. PROCEDURES DURING MISSILE ERECTION.

- 5-8. To locate the following procedures in their operational sequence, refer to ZM-7-200E (TN):
  - a. Verify that 7-49021 support pin shoulders are in place against 7-09229 sockets in thrust structure.
  - b. Insert AN995-AA91 lockwire through holes in 7-49042 links and 7-49038 eyes. Bend lockwire over to retain.
  - c. Install two 7-49070 static-firing links in Quadrants III and IV. Connect only upper, or clevis, end of links to launcher at this time. Apply lubricant to holes and 7-49072 pins before assembly. Tie lower end of each link to lugs on launcher base with heavy rope.

5-9. PROCEDURES AFTER MISSILE ERECTION.

- a. Install two static firing links in Quadrants I and II. Connect only upper or clevis end at this time.
- b. Verify that the following conditions exist before proceeding to step (c) and (d).
  - (1) Missile fuel tank pressure 5 psig (minimum).
  - (2) Launcher leveled on vertical support links.
  - (3) Missile aligned vertically in the tower.
  - (4) Holddown and release cylinders pressurized to 2000 psig.
  - (5) Auxiliary support balance system pressurized.
  - (6) Missile is not in stretch condition.
- c. Verify the vertical location of the missile in the launcher by measuring the distance between the lower surface of the 7-49006 auxiliary support pin shoulder and the upper surface of the 7-49008 cap of the 7-49005 auxiliary support frame. This dimension must be 1.15 maximum inches to 0.85 minimum inches. See figure 5-5. If this distance is not as specified, the launcher release arms must be raised or lowered by readjusting the length of the 7-89366 release cylinders using the procedures specified in Section 4-11d, or 4-11e.

NOTE

The missile must be removed to accomplish this adjustment.

If the distance measured is within the limits specified, proceed with Step "c".

## SECTION V

5-9 (cont'd.)

- d. Verify that the distance between the forward (upper) face of the missile rise-off disconnect panel and the upper surface of the launcher rise-off disconnect panel is  $4.45 \pm 0.15$  inches. This dimension may be verified in the following manner:
- (1) Place one end of a telescopic gage (such as a Starrett #229E-3 $\frac{1}{2}$  to 6 inches) on the upper surface of the launcher disconnect panel adjacent to the tank pressurization disconnect fitting. (large fitting located in the center of each disconnect panel).
  - (2) Extend the telescopic end of the gage until it contacts lower surface of flange on missile half of the tank pressurization disconnect fitting.
  - (3) Lock gage and remove in the locked position.
  - (4) Measure length of gage rod using a 6 inch scale.

If this distance is not within the limits specified, adjust the height of the 27-49021 launcher rise-off disconnect panels using the procedures specified in section 4-17a (1), (2) and (3).

- e. Adjust length of all four static firing links so that holes in bolt ends and holes in lugs on launcher base are aligned. Apply lubricant to holes and 7-49072 pins, and install pins.
- f. Again check 7-49021 support pins for proper engagement as stated in Paragraphs 4-10e. If there is any gap between shoulder of 7-49021 pin and 7-09229 socket assembly, 7-49021 pins must be adjusted as specified in Paragraphs 4-15c through 4-15e. This adjustment can most easily be made with missile stretched.
- g. Connect pod umbilicals as follows:
- (1) Swing open spring loaded clam-shell blast shield on each umbilical plug.
  - (2) Rotate knurled knob at back of plug so that locking pin on contact face of pin is fully extended.
  - (3) Place plug against missile receptacle, inserting locking pin in hole in receptacle.
  - (4) Turn knurled knob clockwise until plug is fully engaged with receptacle. Then rotate knob  $\frac{1}{2}$  turn counterclockwise.
  - (5) Using same procedure as in (4) above, connect booster section umbilical plugs.
  - (6) Connect static ground plug.
  - (7) Connect autopilot 42-inch umbilical to missile.
  - (8) Attach pod cooling ducts to missile accessory pods.
  - (9) Attach thrust area heater duct into firewall.
  - (10) Attach liquid nitrogen overflow ducts to missile thrust barrel.

5-10. PRE-FLIGHT PROCEDURES

- a. Remove four static-firing links prior to a launching.

CAUTION

The release cylinders must be pressurized at all times when the static-firing links have been removed and a missile is in place on the launcher.

- b. Connect lanyards to all umbilical plugs, air conditioning ducts and launcher attach points.
- c. Connect lanyard to gyro disconnect plug (autopilot 42 inch plug) and launcher attach point and secure with lockwire as shown on Drawing 27-49002.
- d. Insert the four lanyard pins into the missile nacelle door restraining lugs and secure with AN995 C32 lockwire as shown on Drawing 27-49055.

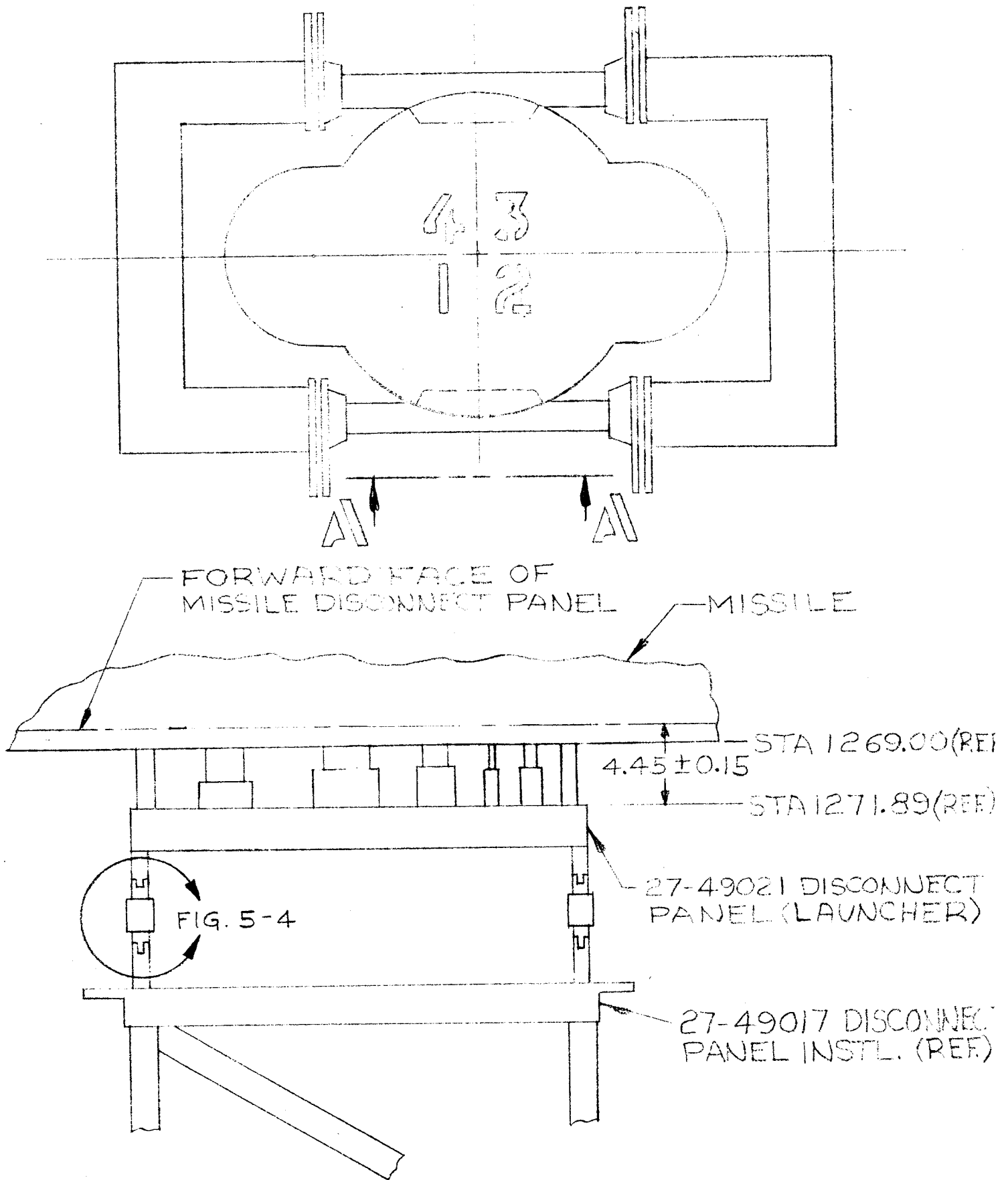

VIEW A-A TYPICAL FOR BOTH PANELS

FIGURE 5-1 ADJUSTMENT OF RISE-OFF DISCONNECT PANELS

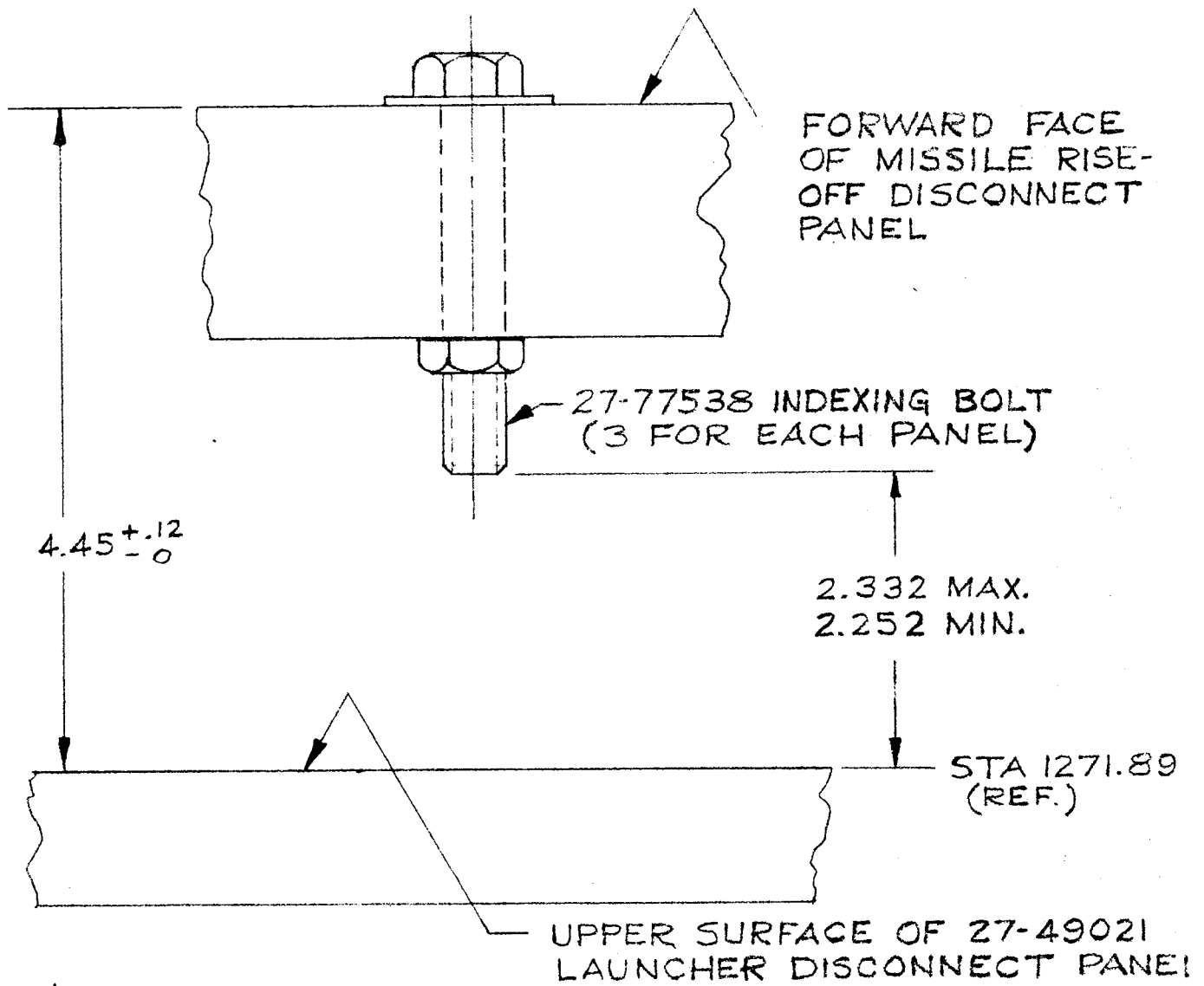
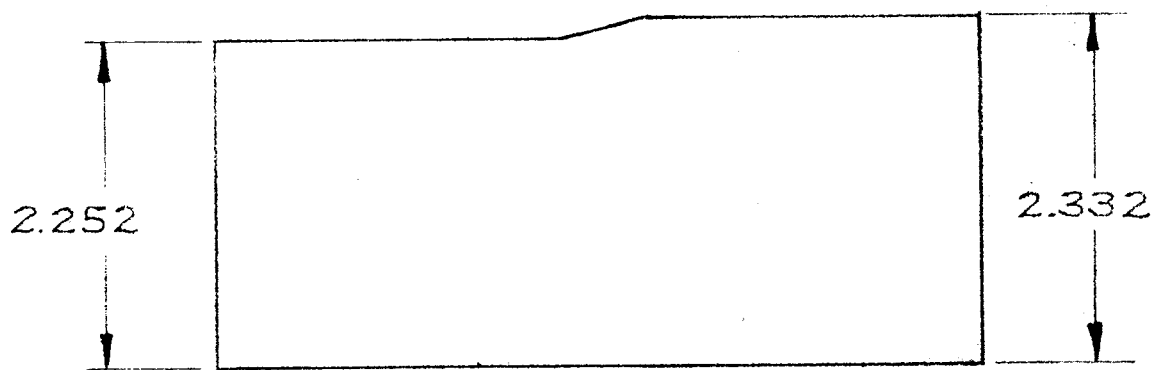

FIGURE 5-2.



SUGGESTED GO OR NOGO GAUGE

FIGURE 5-3.

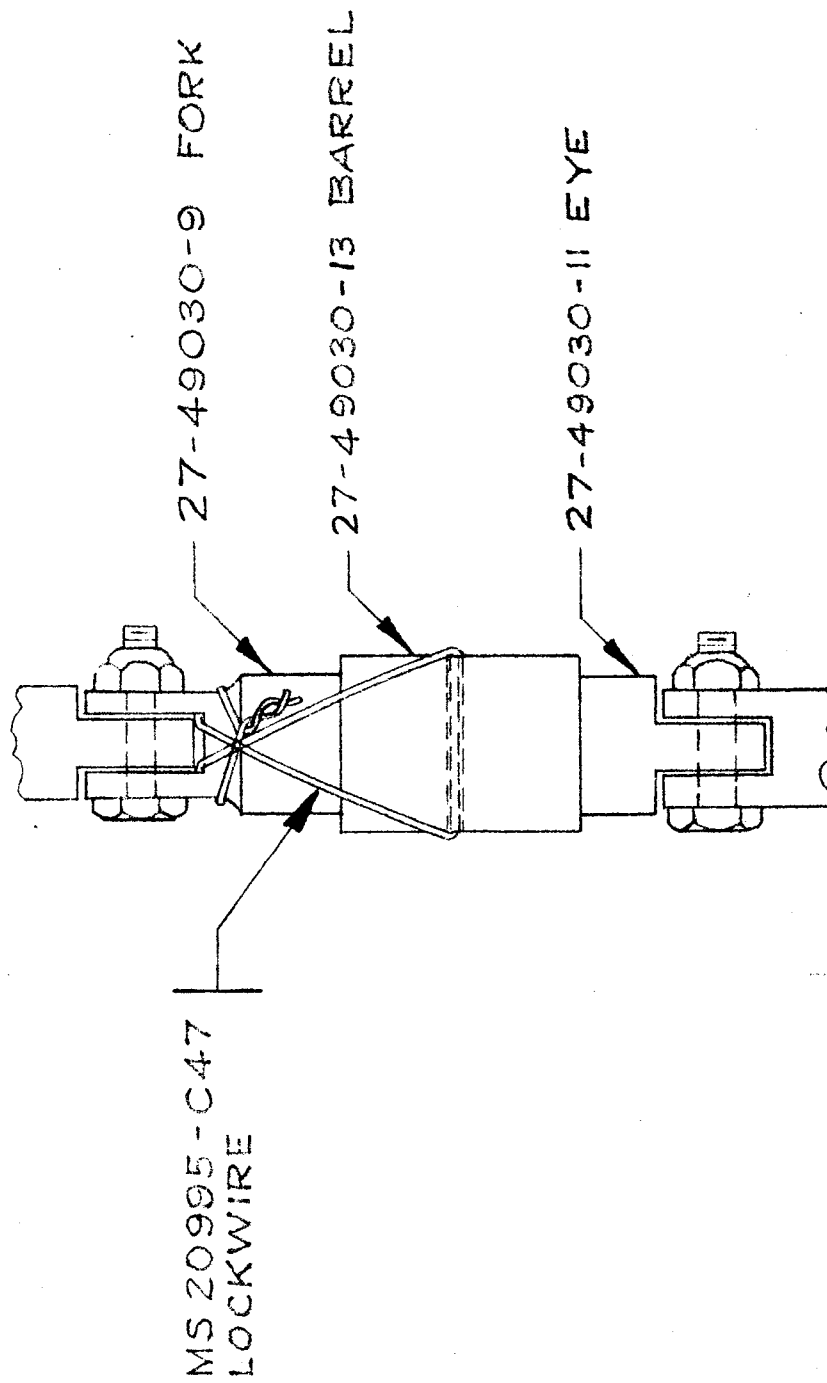

FIGURE 5-4.

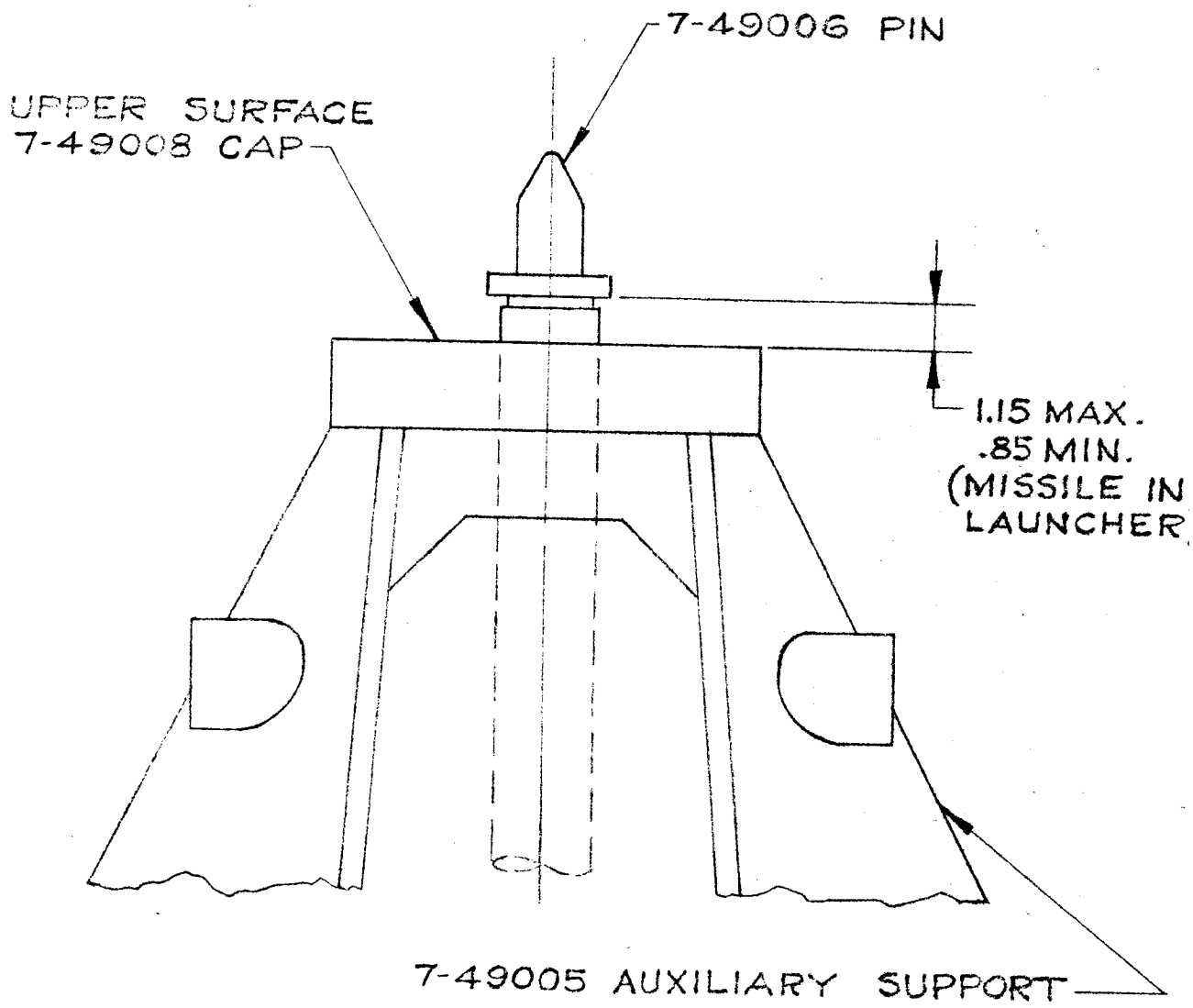

FIGURE 5-5 CHECKOUT OF VERTICAL LOCATION OF MISSILE

## SECTION VI

## POST-LAUNCH OPERATIONS

6-1. PROCEDURES FOR SECURING LAUNCHER AFTER MISSILE LAUNCH.

- a. Shut off electrical, pneumatic, and hydraulic power to launcher.
- b. Move service tower over launcher. (See Section 4-14 for procedure)
- c. Use the tower utility hoist and a cable sling through holes in -71 lugs of 7-49009 arms to raise arms off snubbers. Rotate arms to holddown position. The arms must be lowered slowly and carefully to allow segments in 7-89366 cylinder to engage piston rod.
- d. Release 27-49085 strut assemblies from 7-49019 levers by disengaging 7-49024 lock pins. To disengage lock pins, place a punch through holes in 7-49019 levers and push back 7-49024 lock pins.

WARNING

Disengage the 7-49024 lock pins carefully. The 27-49085 strut assemblies will be thrown downward forcibly by the compressed rubber bumpers.

- e. Release 7-49027 uplocks and lower 7-49019 levers.
- f. Inspect launcher for corrosion damage as specified in Paragraph 7-2.
- g. Replace all damaged parts.
- h. Check out launcher as specified in Paragraphs 4-9 through 4-19 before another missile is loaded.

## SECTION VII

## PREVENTIVE MAINTENANCE

7-1. LAUNCHER INSPECTION

7-2. The launcher shall be inspected weekly for evidences of corrosion.

7-3. The entire launcher assembly shall be inspected before and after each engine test or launching operation for sign of damage and for loose or missing bolts, nuts, or snap rings.

7-4. LAUNCHER LUBRICATION

7-5. Once a week or before and after each engine test or launching operation, the entire launcher and associated equipment shall be lubricated as follows:

- a. Lubricate the grease fittings with a hand-operated or power driven lubrication gun. Use sufficient new lubricant to cause the old lubricant to be forced out from the ends of the journals and bearings.
- b. Coat all the sliding surfaces and exposed machined surfaces with a thick coating of lubricant (RPM#5 grease) except where noted. If the metal shows any signs of corrosion, remove the old lubricant and corrosion before applying the new lubricant.
- c. Coat the exposed portion of all the adjustable threaded surfaces with a thick coating of lubricant (RPM #5 grease) except where noted. If the threads show signs of corrosion, remove all the old lubricant and corrosion before applying the new lubricant.

CAUTION

Do not use RPM #5 grease on any surface which comes in contact with liquid oxygen. ~~The~~ lubricant is distinguished by its purple color to avoid confusion with lubricants compatible with liquid oxygen.

- d. Lubricate the nacelle door lanyard pins with a light coat of RPM#5 grease.
- e. Launcher rise-off disconnect panels: Lubricate the counter bores and retainer plates with a light coat of RPM #5 grease. Apply no grease to the rise-off fittings and use caution when reinstalling to prevent contamination of the fittings, particularly the open ends. Frequency of this lubrication shall be at initial installation of rise-off fittings and whenever fittings are replaced.
- f. Auxiliary support pivot bearings: Use a low temperature oil through fittings provided on auxiliary support frame to lubricate bearings (MIL-L-7870A general purpose, low temperature, lubricating oil). Pack around outside of bearing with a thick coating of RPM #5 grease to prevent moisture from seeping through to bearings and pins.
- g. Auxiliary support pins: Depressurize auxiliary support balance system (only when there is no missile in the launcher). Apply a thick coating of RPM#5 grease to exposed surfaces of pins. Manually exercise pins through full vertical travel to spread grease to entire pin sliding surfaces.

NOTE

All launcher mechanisms are to be thoroughly exercised for proper operation, inspected for evidences of corrosion and lubricated prior to loading a missile in the launcher.

## SECTION VII

7-6. SERVICING THE 7-49276 LAUNCHER SNUBBERS

- 7-7. Check the fluid level in the 7-49276 snubbers before each launching operation. Fill with hydraulic oil MIL-O-5606 to the level of the filler plug while the piston rod is extended (with the snubbers in the vertical position). If the snubbers have been drained or if the fluid level is extremely low, use the following procedure for filling: (capacity approx 2.5 gallons)
- Unscrew the 7-49262 cap at the top of the snubber housing.
  - Lift the entire piston and rod assembly weighing 90 pounds, out of the barrel.
  - Pour hydraulic oil into the snubber barrel until the level of the oil is approximately 6 inches below the filler plug. Place a container under the filler plug to catch the excess fluid.

CAUTION

- Do not permit dirt or other foreign matter to enter the snubber barrel.
- Insert the piston and rod assembly.
  - Tighten the 7-49262 cap.
  - The snubber should now be full to the level of the filler plug; if not, add oil through the filler plug hole.
  - After the snubber has been adjusted dimensionally, as explained in paragraph 4-12, recheck the fluid level.

7-8. PERIODIC INSPECTION OF SNUBBER ASSEMBLY

- 7-9. The snubber assemblies shall be inspected weekly for evidences of corrosion.

7-10. LUBRICATION OF SNUBBER ASSEMBLY

- 7-11. Once a week or before and after each launching operation, the snubber assemblies are to be lubricated as follows:
- Lubricate the snubber assemblies and barrel strut attachment points where special fittings are provided using RPM #5 grease. Use sufficient new lubricant to cause the old lubricant to be forced out from the ends of the journals and bearings. See paragraph 7-4 for launcher lubrication procedure.

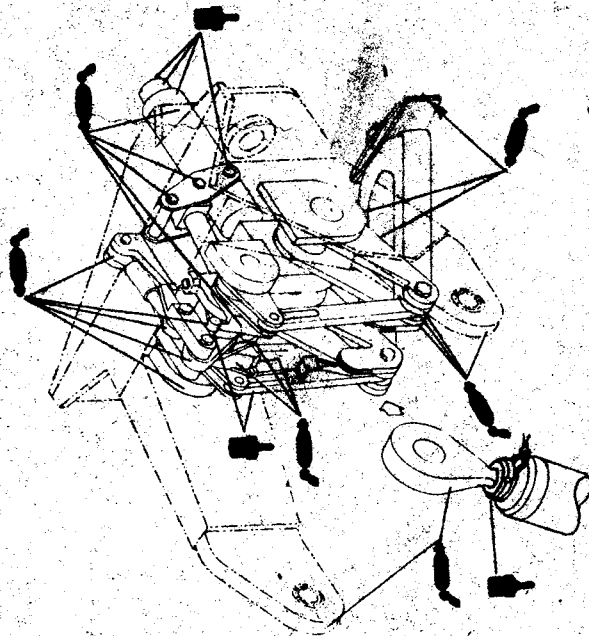
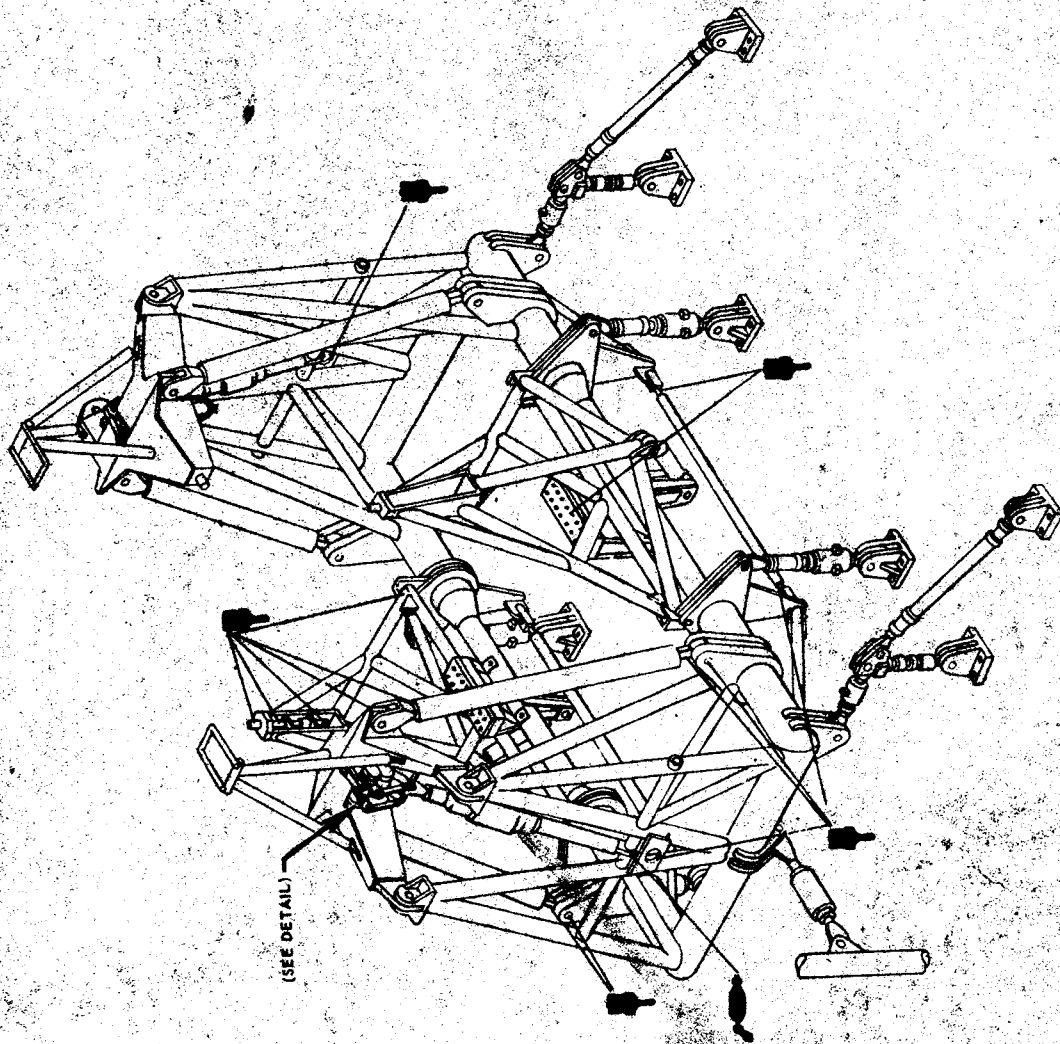

ARM MECHANISM ASSEMBLY DETAIL

PREFERRED GREASE LUBRICANT IS  
RPM AVIATION GREASE NO. 5.

(LUBE POINTS FOR IDENTICAL PARTS  
USUALLY SHOWN ON ONE PART ONLY)

USE GUN, GREASE FITTING

BRUSH OR WIPE ON THIN  
COATING OF GREASE

Figure 7-1. LUBRICATION CHART

## SECTION VIII

## TROUBLESHOOTING

8-1. USE OF THE TROUBLESHOOTING SECTION.

8-2. This section consists of a troubleshooting table to provide information useful in diagnosing and, if practical, correcting any unsatisfactory operation or failure of the launcher mechanism. (Refer to table 8-1.) Corrective measures to be taken do not comprehend major repairs or rebuilding of the mechanism. Upon locating the trouble and determining the primary cause, always check for and correct any secondary or contributing conditions that may exist.

8-3. CAUTIONS IN TROUBLESHOOTING.

8-4. Exploratory troubleshooting can be extremely expensive in both time and money if maintenance personnel are not thoroughly familiar with the item of equipment as well as its spare parts support. The operator and maintenance personnel must use caution in attempting component field repairs that are not supported in the spare parts system. At times it may be more economical to replace than to repair a low-cost item. Further, there are certain items of equipment that require factory repair and are made useless and unrepairable if disassembled in the field.

TABLE 8-1. TROUBLESHOOTING THE LAUNCHER MECHANISM

TROUBLE	POSSIBLE CAUSE	POSSIBLE REMEDY
Roughness noted when rotating arm assembly. Sticking or binding noted in mechanism.	<p align="center"><u>ARM AND MECHANISM ASSEMBLY</u></p> Broken or damaged roller bearing in arm pivot. Rust in bearings or sliding surfaces. Bent or damaged components in mechanism. Improper lubrication	Replace bearing.  Remove rust. Replace bent or damaged components. Lubricate properly. (See paragraph 7-4)
The 7-49042 links do not raise from the stops on arm.	Mechanism not properly adjusted.  Broken rollers on 7-49049 bell cranks. Wrong material used for shear wire	Readjust mechanism. (See paragraphs 4-14d, 4-14e) Replace rollers. Use AN 995-AA91 shear wire
The 7-49019 levers will not lock in up position.	The 7-49027 uplock not properly adjusted. The 7-49027 uplock bent. The 7-49026 spring is defective.	Readjust uplock. (See paragraph 4-14h) Replace uplock. Replace the spring.
The 27-49085 strut assy will not lock against 7-49019 lever.	Broken lock pin spring.  Bent 7-49024 lock pin.	Replace lock pin spring. Replace lock pin.
Binding or irregular motion noted in auxiliary supports.	<p align="center"><u>AUXILIARY SUPPORTS</u></p> Damaged actuator cylinder  Corroded or damaged pivot	Replace actuator cylinder. Replace pivot bearings.