

UNCLASSIFIED

AD NUMBER

AD834482

LIMITATION CHANGES

TO:

Approved for public release; distribution is unlimited.

FROM:

Distribution authorized to U.S. Gov't. agencies only; Administrative/Operational Use; 1964. Other requests shall be referred to US Army Management School, Fort Belvoir, VA 22040.

AUTHORITY

USAMS ltr 29 Apr 1971

THIS PAGE IS UNCLASSIFIED

V

# MANAGEMENT VIEWS

887200

*Alphabet of the  
Army Management*

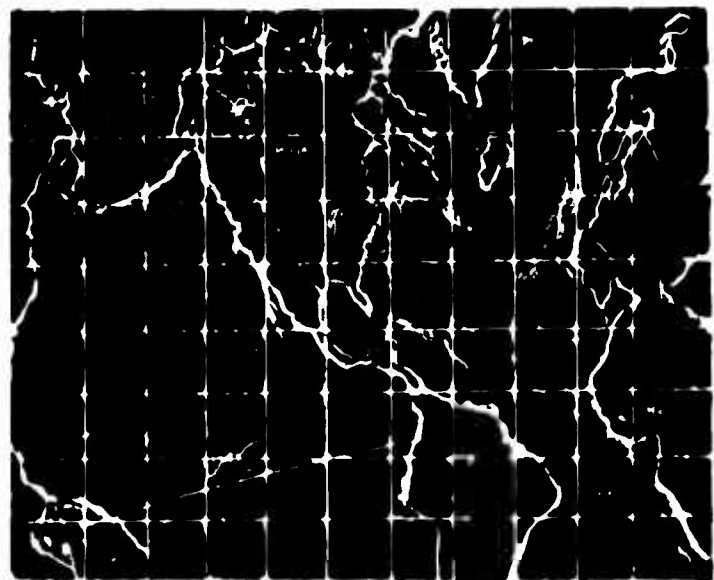

## TOP MANAGEMENT in the military

### Management of Army FIELD COMMANDS

VOL. IX/PART 1 SELECTED SPEECHES

ACADEMIC YEAR 63-64

U.S. ARMY MANAGEMENT SCHOOL

FORT BELVOIR, VIRGINIA

# MANAGEMENT VIEWS

Transcriptions of Selected  
Oral Presentations Made at  
U. S. Army Management School  
1963-64

## VOL. IX

### Part 1

TOP MANAGEMENT IN THE MILITARY  
MANAGEMENT OF ARMY FIELD COMMANDS

### Part 2

*(Published Separately)*

ADVANCED SYSTEMS AND TECHNIQUES  
MODERN BUSINESS MANAGEMENT  
MILITARY APPLICATION OF MODERN MANAGEMENT  
TECHNIQUES  
MANAGEMENT IN THE FEDERAL GOVERNMENT

### Part 3

*(Published Separately)*

HUMAN FACTORS IN MANAGEMENT  
CREATIVE PROBLEM SOLVING

Information as to availability of any of the three parts of Vol. IX should be addressed to School Secretary, USAMS, Fort Belvoir, Virginia 22060.

U. S. ARMY MANAGEMENT SCHOOL  
Fort Belvoir, Virginia  
1964

## PREFACE TO VOL. IX

The vast and rapid changes in our modern world forcefully accentuate the increasing need for the best possible management of our Armed Forces. One method employed by the U. S. Army Management School to promote an increase in knowledge and a broadening of experience on the part of course participants is to present a highly diversified guest-speaker program.

Senior military leaders, prominent educators, and eminently successful business executives have presented a wide range of concepts and experiences. All of these presentations have been invaluable in achieving the objectives of this School, namely, to motivate participants to broaden their knowledge, to re-examine their attitudes and habits, and to improve their skills and techniques.

Publication and distribution of these volumes is made in order to assist military and government officials to keep abreast of the latest trends and current thinking in management.

They also serve as a token of appreciation to those speakers whose ideas and experience are reflected in *Management Views*. They have given most generously of their time and made significant contributions to the United States Army and the success of this School.

1 Sept. 1964



C. C. COYNE  
Colonel, Artillery  
Commandant

# CONTENTS

	<i>Page</i>
Preface to Vol. IX Colonel C. C. Coyne .....	ii
<b>Cumulative Speaker Index to Vols. I-VIII .....</b>	<b>v</b>

## TOP MANAGEMENT IN THE MILITARY

<i>The Management Concept of Mr. Robert S. McNamara, The Secretary of Defense</i> Honorable Solis Horwitz .....	1
<i>Some Remarks on Comptrollership in Today's Army</i> Lieutenant General Robert Hackett .....	25
<i>Management in the U. S. Air Force</i> Lieutenant General F. A. Bogart .....	46
<i>Planning, Programing, and Budgeting at Department of Army Headquarters</i> Brigadier General Leonard C. Shea .....	65
<i>Concepts of the Command Channel Stock Fund</i> Mr. James C. Jenkins .....	90

## MANAGEMENT OF ARMY FIELD COMMANDS

<i>Army Materiel Command</i> General Frank S. Besson, Jr. ....	105
<i>The Combat Developments Command Program</i> Lieutenant General Dwight E. Beach .....	121
<i>Progress of the Defense Supply Agency</i> Major General Ray J. Laux .....	144
<i>The Mobility Environment</i> Major General Alden K. Sibley .....	158

	<i>Page</i>
<i>Control of a Major Enterprise</i> Major General William B. Bunker .....	173
<i>Some Problems in Managing a Military Installation</i> Major General Charles W. G. Rich .....	190
<i>Some Remarks on Management at the Army Weapons Command</i> Major General Nelson M. Lynde, Jr. ....	206
<i>The Challenge of Post Management</i> Major General Harry H. Critz .....	211
<i>Operations of the Supply and Maintenance Command</i> Major General Robert C. Kyser .....	231
<i>Managing the Test and Evaluation Command</i> Major General James W. Sutherland, Jr. ....	243
<i>Project Management</i> Brigadier General C. W. Eifler .....	256
<i>Internal Auditing and the Army Audit Agency</i> Mr. James A. Robbins .....	274
<i>Speaker Index to Part I</i> .....	282

CUMULATIVE SPEAKER INDEX  
TO VOLS. I-VIII\*

- AHERN, Joseph P., Col.** "ACMS at Class II Installations." *Speeches*, 1957, Part 1, pp. 23-39.
- ANDERSON, Joseph A., Mr.** "Managing for Maximum Creativity." *Management Views*, 1961-62, pp. 541-553.
- ANSON, Richard W., Capt.** "An Insight Into Operations Research." *Management Views*, Vol. VIII, Part 1, 1962-63, pp. 271-305.
- ARGYRIS, Chris.** "Human Behavior in Organization." *Speeches*, 1957, Part 2, pp. 141-162.
- ARNOLD, William H., Lt. Gen.** "Fifth Army Management." *Speeches*, 1960, Part 1, pp. 14-28.
- AULT, T. J., Mr.** "Diversification of Management." *Speeches*, 1957, Part 2, pp. 118-140.  
"Management Today, Tomorrow." *Speeches*, 1956, pp. 40-48.
- BARNETT, Frank R., Mr.** "New Dimensions in National Strategy." *Speeches*, 1959, Part 2, pp. 247-267.
- BARTON, Douglas C., Lt. Col.** "ACMS at Class I Installations." *Speeches*, 1957, Part 1, pp. 12-22.
- BEARE, Gene K., Mr.** "The Creative Manager." *Management Views*, Vol. VIII, Part 2, 1962-63, pp. 541-552.
- BEAUCHAMP, Charles E., Maj. Gen.** "Financial Management at Fort Dix." *Management Views*, Vol. VIII, Part 1, 1962-63, pp. 48-80.
- BENDETSSEN, Karl R., Mr.** "Organization Man and the Military Mind." *Speeches*, 1960, Part 2, pp. 193-206.
- BESSON, Frank S., Jr., Lt. Gen.** "Decision by Design." *Management Views*, Vol. VIII, Part 1, 1962-63, pp. 19-47.
- BLACKWOOD, George W., Mr.** "Evolution of a Management Philosophy." *Speeches*, 1959, Part 2, pp. 36-57 (contains Q & A); *Speeches*, 1960, Part 2, pp. 11-27 (reprint w/o Q & A).
- BLEND, D. W., Mr.** "Management Advisory Committee System." *Speeches*, 1960, Part 1, pp. 113-133 (w/ Q & A); *Speeches*, 1960, Part 2, pp. 234-249 (reprint w/o Q & A).  
"Multiple Management." *Speeches*, 1959, Part 2, pp. 110-131.
- BORKLUND, C. W., Mr.** "The Problems of the Defense-Industry Relationship." *Management Views*, Vol. VIII, Part 2, 1962-63, pp. 553-571.

\*This index lists those speakers whose speeches were published in the annual speech book for the period 1956 through June 1963.

The speech book was titled *Speeches* for Vols. I-V, 1956-60. Beginning with Vol. VI, 1961, the title was changed to *Management Views*.

Not listed in this index are those speakers whose speeches appear in Vol. IX. See the separate indexes at the end of Parts 1-3 for these speakers.

- BOWEN, F. S., Jr., Maj. Gen.** "Problems of a Post Commander in Installing the Army Command Management System." *Speeches*, 1956, pp. 155-168.
- BRISTOL, Lee H., Jr., Dr.** "The Bristol-Myers Story." *Management Views*, 1961-62, pp. 517-531.
- BROWN, Alvin, Mr.** "How to Organize." *Speeches*, 1957, Part 2, pp. 47-66; *Speeches*, 1959, Part 2, pp. 58-73 (reprint).
- BROWN, T. A., Capt., USN.** "Management at the Defense General Supply Center." *Management Views*, Vol. VIII, Part 2, 1962-63, pp. 420-432.
- BRUCKER, Wilber M., Hon.** "Address." *Speeches*, 1960, Part 2, pp. 104-110.
- BUEHLER, V. M., Lt. Col.** "Accounting Aspects of ACMS." *Speeches* 1957, Part 1, pp. 1-11.
- BURNETT, J. W., Col.** "Programing at United States Continental Army Command." *Speeches*, 1959, Part 1, pp. 64-76.
- CAPITO, Charles E., Col.** "Management at New Cumberland General Depot." *Speeches*, 1960, Part 1, pp. 47-67.
- CASHMAN, Paul H., Dr.** "Listening—A Vital Skill." *Management Views* 1961, pp. 336-343.
- CHANDLER, Burton B., Lt. Col.** "The Nature of Management." *Speeches*, 1958, Part 1, pp. 28-34.  
"The Philosophy of Management." *Speeches*, 1956, pp. 1-9.
- CHANDLER, R. Carl, Mr.** "Building a Growth Company." *Management Views*, Vol. VIII, Part 2, 1962-63, pp. 572-598.  
"Building a Growth Company with a Planned Program." *Management Views*, 1961, pp. 253-267.
- CHILES, H. E., Jr., Mr.** "Building the Top Management Team." *Speeches*, 1959, Part 1, pp. 42-53.
- CHRISTENSEN, John M., Jr., Col.** "Advanced Management Systems and Techniques." *Management Views*, Vol. VIII, Part 1, 1962-63, pp. 218-248.
- CLARKE, Bruce C., Gen.** "Address Before First Army Management Orientation Course." *Speeches*, 1959, Part 1, pp. iii-viii.  
"Army Management." *Speeches*, 1960, Part 1, pp. 10-13.
- COLGLAZIER, R. W., Jr., Lt. Gen.** "Logistics Management." *Management Views*, 1961-62, pp. 114-118.  
"Logistics Management in Today's Army." *Management Views*, 1961, pp. 47-56.
- COLLINS, James F., Lt. Gen.** "Command and Management." 1961, pp. 33-46.
- CYR, Arthur R., Col.** "Management of an AIF Installation." *Management Views*, 1961, pp. 199-213.
- DALE, Ernest, Prof.** "Decentralization." *Speeches*, 1959, Part 2, pp. 132-148.

- DAVIS, Chester R., Hon.** "Financial Management at the Department of the Army." *Speeches*, 1957, Part 1, pp. 114-127.  
 "The Fiscal Year 1957 Army Budget." *Speeches*, 1956, pp. 176-186.
- DECKER, George H., Gen.** "The Challenge to Army Management." *Management Views*, 1961, pp. 1-11.
- DECKER, William C., Mr.** "Improving the Effectiveness of Management." *Speeches*, 1957, Part 2, pp. 67-84 (w. Q & A); *Speeches*, 1959, Part 2, pp. 160-177 (reprint w different Q & A).
- DEVORE, Leland S., Jr., Lt. Col.** (Excerpt from General Management Seminar.) *Speeches*, Part 2, 1957, pp. 229-233.
- DONOHUE, Maurice F. X., Dean.** "Society and the Administrator." *Speeches*, 1958, Part 1, pp. 1-27.
- DRUCKER, Peter F., Dr.** "Spirit of an Organization." *Speeches*, 1956, pp. 49-56.  
 "Trends in Management Thinking." *Speeches*, 1958, Part 2, pp. 19-29.
- DUFF, Charles B., Maj. Gen.** "Programing at the Department of the Army." *Speeches*, 1960, Part 1, pp. 192-203.
- EASTERBROOK, Ernest F., Maj. Gen.** "Management at Fort Rucker." *Management Views*, 1961-62, pp. 177-190.
- EIFLER, C. W., Col.** "Management Needs Systems Engineering." *Management Views*, 1961-62, pp. 324-350.
- ENGLER, J. E., Maj. Gen.** "Logistical Management at Headquarters USCONARC." *Speeches*, 1960, Part 2, pp. 72-88.  
 "Logistical Management at USCONARC." *Management Views*, 1961, pp. 92-108.
- FAITH, Don C., Brig. Gen. (Ret.).** "Leadership." *Speeches*, 1957, Part 1, pp. 166-177.
- FINKE, W. W., Mr.** "Electronic Data Processing." *Management Views*, 1961-62, pp. 583-591.
- FISCHER, Harvey, Maj. Gen.** "Management at Fort Riley (ACMS)." *Speeches*, 1960, Part 1, pp. 29-46.
- FORIO, Edgar J., Mr.** "Philosophy of Public Relations in Management." *Speeches*, 1959, Part 2, pp. 192-197; *Management Views*, 1961, pp. 268-274 (reprint).
- FOSTER, Hugh F., Jr., Lt. Col.** "Automatic Data-Processing Systems—An Aid to Army Management." *Speeches*, 1960, Part 1, pp. 204-231.  
 "Class I Installation Data-Processing System Prototype at Fort George G. Meade, Maryland." *Management Views*, 1961, pp. 239-252.
- FOX, John M., Mr.** "What It Takes To Be a Manager." *Speeches*, 1956, pp. 78-90.

- FOY, Fred C., Mr.** "The Control Section As an Aid to Management." *Speeches*, 1956, pp. 135-141.
- FREEMAN, Paul L., Jr., Lt. Gen.** "Management at the Installation Level." *Management Views*, 1961, pp. 57-69; *Management Views*, 1961-62, pp. 35-46 (reprint).
- GANZ, Louis A., Mr.** "Men At Work." *Speeches*, 1957, Part 2, pp. 200-228.
- GATES, James E., Dean.** "Applied Imagination and Creative Thinking." *Speeches*, 1958, Part 1, pp. 35-51 (w/Q & A); *Speeches*, 1959, Part 2, pp. 178-191 (reprint, w/different Q & A); *Management Views*, 1961, pp. 344-355 (reprint); *Management Views*, 1961-62, pp. 424-435 (reprint).
- GERHARDT, Harrison A., Maj. Gen.** "Congress and the Military." *Management Views*, 1961-62, pp. 191-202.
- GERMANE, Gayton E., Dr.** "Centralization and Decentralization." *Management Views*, Vol. VIII, Part 2, 1962-63, pp. 599-608.
- GILBRETH, Lillian M., Dr.** "The Human Side of Automation." *Speeches*, 1957, Part 2, pp. 181-199.
- GREEN, Edward J., Mr.** "Management by Objectives for More Effective Operations." *Management Views*, 1961, pp. 275-284. "The Managerial Lag." *Speeches*, 1959, Part 2, pp. 149-159.
- HALL, Herbert A., Brig. Gen.** "Command Management." *Speeches*, 1958, Part 2, pp. 51-57.
- HAMLETT, Barksdale, Lt. Gen.** "Readiness—The Product of Army Management." *Management Views*, 1961, pp. 70-76; *Management Views*, 1961-62, pp. 27-34 (reprint).
- HANEKE, W. C., Col.** "The Application and Management Uses of Cost and Performance Data." *Speeches*, 1959, Part 2, pp. 224-237.
- HANSEN, F. A., Maj. Gen.** "The U. S. Army Munitions Command." *Management Views*, Vol. VIII, Part 1, 1962-63, pp. 81-109.
- HARDING, H. F., Dr.** "Can You Drive the Triple I Turnpike?" *Speeches*, 1960, Part 2, pp. 207-219.
- HARVEY, Oliver C., Maj. Gen.** "How I Influence Management at the Defense Clothing and Textile Supply Center." *Management Views*, 1961-62, pp. 280-299; *Management Views*, Vol. VIII, Part 2, 1962-63, pp. 339-364. "Uses of the Army Command Management System at a General Depot." *Speeches*, 1959, Part 2, pp. 207-223.
- HAUCK, Clarence Jonathan, Jr., Brig. Gen.** "Reorganization of the Defense Department." *Speeches*, 1959, Part 1, pp. 16-32.
- HAYES, James L., Dean.** "A Philosophy of Management Development." *Speeches*, 1960, Part 1, pp. 145-174 (w/Q & A); *Speeches*, 1960, Part 2, pp. 152-172 (reprint); *Management Views*, 1961, pp. 356-368; *Management Views*, 1961-62, pp. 475-489 (reprint); *Management Views*, Vol. VIII, Part 2, 1962-63 (reprint).

- HAYES, John J., Col.** "The Army Industrial Fund." *Speeches*, 1956, pp. 169-175.
- HERSHEY, R. L., Dr.** "Committee Line Management." *Management Views*, 1961-62, pp. 562-573.
- HEWITT, Robert A., Maj. Gen.** "Personnel Management in the Department of the Army." *Management Views*, Vol. VIII, Part 1, 1962-63, pp. 110-130.
- HITCH, Charles J., Hon.** "The Implication of Programing in Defense Management." *Management Views*, 1961-62, pp. 351-359.
- HOELSCHER, L. W., Mr.** "Role of Comptrollership in the Army." *Speeches*, 1958, Part 1, pp. 167-181.
- HOFF, Stuart S., Maj. Gen.** "Military Management—An Area To Explore." *Management Views*, Vol. VIII, Part 1, 1962-63, pp. 131-142.
- HOFMANN, Philip B., Mr.** "Centralization vs. Decentralization." *Speeches*, Part 1, 1958, pp. 98-104.
- HOPE, Stanley C., Mr.** "My Philosophy of Management." *Speeches*, 1958, Part 1, pp. 71-97.
- HORWITZ, Solis, Mr.** "Secretary McNamara's Concept of Management." *Management Views*, Vol. VIII, Part 2, 1962-63, pp. 433-455.
- HOUSEMAN, Evan M., Maj. Gen.** "The Industrial Fund Concept." *Speeches*, 1957, Part 1, pp. 40-64.  
"Management Problems." *Speeches*, 1958, Part 2, pp. 131-140.
- HYMAN, Paul J., Mr.** "Use of ADP in Defense Materiel Management." *Management Views*, 1961-62, pp. 372-391.
- IVES, Dudley H., Maj. Gen.** "The Role of the Inspector General in Management." *Management Views*, 1961-62, pp. 137-148.
- JAMES, Clifford C., Mr.** "The Changing Management Concept." *Speeches*, 1956, pp. 10-22.
- JARMAN, Burnice H., Dean.** "Motivation." *Speeches*, 1958, Part 1, pp. 52-70 (w/Q & A); *Speeches*, 1959, Part 2, pp. 6-21 (reprint); *Speeches*, 1960, Part 2, pp. 111-126 (reprint); *Management Views*, 1961-62, pp. 497-516 (reprint)
- JOHNSON, Robert E., Mr.** "Cost Reduction Through Operations Research." *Speeches*, 1958, Part 2, pp. 89-99.
- JOHNSON, W. Paul, Maj. Gen.** "Management at Fort Knox." *Management Views*, 1961, pp. 109-128.
- KENDERDINE, John M., Brig. Gen.** "Developments and Impacts of MILSTRIP and MILSTAMP." *Management Views*, Vol. VIII, Part 2, 1962-63, pp. 390-419.
- KLANDERMAN, R. R., Col.** "Management of an Industrial Fund at Picatinny Arsenal." *Management Views*, 1961-62, pp. 300-323.
- KUSIK, John E., Mr.** "Coolie Chains of Human Communication." *Speeches*, 1956, pp. 115-119.  
"Why a Railroad Must Grow." *Speeches*, 1957, Part 2, pp. 105-117.

- LARSEN, Finn J., Hon.** "Management in Research and Development." *Management Views*, Vol. VIII, Part 1, 1962-63, pp. 1-8.
- LAWTON, William S., Lt. Gen.** "Current Highlights in Army Comptrollership at Department of the Army Level." *Speeches*, 1959, Part 2, pp. 238-246.
- LEWIS, Ronello B., Mr.** "Accounting Reports for Management." *Speeches*, 1958, Part 1, pp. 196-203.  
"The Role of the Comptroller in Industry." *Speeches*, 1956, pp. 96-107.
- LIPPITT, Gordon, Dr.** "Characteristics of Groups in Organizations." *Speeches*, 1960, Part 2, pp. 186-192; *Management Views*, 1961, pp. 369-376 (reprint); *Management Views*, 1961-62, pp. 490-496 (reprint).
- LUNDIN, E. J., Mr.** "Concepts of the Horizontal Stock Fund." *Management Views*, Vol. VIII, Part 1, 1962-63, pp. 306-336.
- LYLE, J. M., Rear Adm.** "Defense Supply Agency—After One Year." *Management Views*, Vol. VIII, Part 2, 1962-63, pp. 365-389.
- LYNN, William M., Jr.** "The Army's Planning, Program, and Budget Systems." *Management Views*, 1961, pp. 214-238.
- MACAROW, Frederick, Mr.** "The Executive Task." *Speeches*, 1957, Part 2, pp. 163-180.
- MacLAUGHLIN, Victor J., Maj. Gen.** "Applied Management at the Defense General Supply Center." *Management Views*, 1961-62, pp. 203-238.
- MACY, John W., Jr.** "Civilian Career Service." *Speeches*, 1956, pp. 120-134.
- MAROUN, Autrey J., Brig. Gen.** "Role of the Comptroller, USAREUR." *Speeches*, 1959, Part 1, pp. 108-116.
- MARTIN, N. H., Mr.** "Strategy and Tactics of Management." *Speeches*, 1958, Part 2, pp. 58-76.
- McCRACKEN, Paul W., Dr.** "The Economic Outlook." *Speeches*, 1958, Part 1, pp. 149-166.
- McDANIEL, Edward H., Maj. Gen.** "Manpower Plan at Department of the Army." *Speeches*, 1957, Part 1, pp. 128-145.
- McELHENY, John D., Col.** "Project ARM (Army Ready Materiel)." *Management Views*, Vol. VIII, Part 1, 1962-63, pp. 249-270.
- McGARR, Lionel C., Maj. Gen.** "Uses of ACMS at a Class I Installation." *Speeches*, 1960, Part 2, pp. 28-54.
- McNAMARA, A. T., Lt. Gen.** "Defense Supply Agency." *Management Views*, 1961-62, pp. 119-136.
- McNEIL, W. J., Hon.** "Financial Management and Policy." *Speeches*, 1956, pp. 142-154.
- MILTON, Hugh M., II, Hon.** "Management in the Army." *Speeches*, 1960, Part 1, pp. 1-9.

- MITCHELL, Don G., Mr.** "Assuring a Dynamic Organization." *Speeches*, 1956, pp. 57-65; *Speeches*, 1960, Part 1, pp. 82-93 (reprint w/Q & A); *Management Views*, 1961, pp. 285-293 (reprint); *Management Views*, 1961-62, pp. 574-582 (reprint).  
"Dynamic Management." *Speeches*, 1957, Part 2, pp. 85-104.
- MITCHELL, Robert C., Mr.** "A Talk on 'Decentralization'." *Speeches*, 1958, Part 2, pp. 77-88.
- MOORE, Leo B., Prof.** "Motivation." *Management Views*, 1961-62, pp. 436-448.
- MOSEL, James N., Prof.** "Motivation." *Management Views*, 1961, pp. 377-402; 1961-62, pp. 449-474 (reprint).  
"Managing and Changing Organizations." *Management Views*, Vol. VIII, Part 2, 1962-63, pp. 472-503.
- MYERS, Samuel L., Maj. Gen.** "Management of MAAG Vietnam." *Speeches*, 1960, Part 1, pp. 68-81.
- NADEN, William, Mr.** "Management Philosophy and Executive Development." *Speeches*, 1958, Part 1, pp. 105-113.
- ONCKEN, William, Jr.** "Communication and Human Relations." *Speeches*, 1960, Part 2, pp. 127-151 (w/Q & A); *Management Views*, 1961, pp. 294-311 (reprint w o Q & A).
- PLOWMAN, E. G., Mr.** "Centralization and Decentralization." *Management Views*, 1961, pp. 312-320; 1961-62, pp. 592-600 (reprint).  
"Communication as a Management Technique." *Speeches*, 1957, Part 2, pp. 219-228.  
"Decentralization." *Speeches*, 1958, Part 1, pp. 114-122.  
"Decentralization." *Speeches*, 1960, Part 1, pp. 134-144 (differs from above).
- POWELL, Grosvenor F., Col.** "Uses of the Army Industrial Fund System." *Speeches*, 1959, Part 1, pp. 92-107.
- POWELL, Herbert B., Gen.** "Practicality—The Goal for Army Management." *Management Views*, 1961, pp. 12-20.  
"Views on Army Management." *Management Views*, 1961-62, pp. 1-10.
- POWELL, J. Lewis, Mr.** "The Collapse of Time." *Speeches*, 1958, Part 2, pp. 1-18.  
"Digest of 'Muscles to Missiles' ('The Collapse of Time')." *Speeches*, 1959, Part 2, pp. 22-35; 1960, Part 2, pp. 220-233 (reprint); *Management Views*, 1961, pp. 162-176 (reprint); 1961-62, pp. 409-423 (reprint).
- PRINCE, George M., Mr.** "Developing an Ability To Solve Problems Inventively." *Management Views*, Vol. VIII, Part 2, 1962-63, pp. 609-625.
- RANCK, J. R., Brig Gen.** "The Depot Command Management System." *Speeches*, 1957, Part 1, pp. 65-92.

- RATHE, Alex W., Mr.** "Communications." *Speeches*, 1956, pp. 108-113.
- RICH, C. W. G., Maj. Gen.** "Management at Fort Campbell." *Management Views*, 1961-62, pp. 248-279
- ROBBINS, James A., Mr.** "Internal Auditing in the Army." *Speeches*, 1958, Part 2, pp. 110-118.  
 "Internal Auditing in the Army." *Management Views*, 1961, pp. 177-181 (differs from above).
- RODERICK, George H., Hon.** "The Army's Financial Management Plan." *Speeches*, 1959, Part 2, pp. 198-206.  
 "Climate for Creativity." *Management Views*, 1961-62, pp. 554-561.  
 "Financial Management." *Speeches*, 1958, Part 1, pp. 182-195.  
 "Formulation of the Army Budget." *Speeches*, 1959, Part 1, pp. 54-63.  
 "How About a Functional Budget?" *Speeches*, 1960, Part 2, pp. 1-10.
- RUFFNER, Clark L., Gen.** "Management Aspects of the Modern Army." *Management Views*, 1961, pp. 21-32.
- RUGGLES, John F., Maj. Gen.** "Post Operation and Unit Command under the Army Command Management System." *Management Views*, Vol. VIII, Part 1, 1962-63, pp. 143-157.
- SALET, Eugene A., Maj. Gen.** "Management Is Command." *Management Views*, Vol. VIII, Part 1, 1962-63, pp. 158-171.
- SCHAUB, W. F., Hon.** "Top Management in a Changing Climate." *Management Views*, 1961-62, pp. 360-371.
- SEBREE, E. B., Maj. Gen.** "Leadership." *Speeches*, 1956, pp. 91-95.
- SECKLER-HUDSON, Catheryn, Dean.** "The Executive of Tomorrow." *Speeches*, 1959, Part 1, pp. 1-15.
- SECORD, Arthur, Dr.** "Motivation." *Speeches*, 1960, Part 1, pp. 175-191 (w/ Q & A); *Management Views*, 1961, pp. 403-419 (reprint w/o Q & A).
- SHARTLE, Carroll L., Prof.** "Administrative Leadership." *Speeches*, 1956, pp. 66-77.
- SIMBERG, Alvin L., Mr.** "The 'Why' of Creativity." *Management Views*, Vol. VIII, Part 2, 1962-63, pp. 626-644.
- SMIDDY, Harold F., Mr.** "Management Development Progress at General Electric." *Speeches*, 1957, Part 2, pp. 1-31.  
 "Managerial Decision Making." *Speeches*, 1958, Part 2, pp. 30-50.  
 "Present Status of the Work of Managing." *Speeches*, 1956, pp. 23-39.
- SMITH, Nicholas M., Dr.** "The New Science of Management Decision." *Management Views*, Vol. VIII, Part 2, 1962-63, pp. 645-678.
- SMITH, Sheldon P., Mr.** "Management of an Army Ordnance Guided Missile Plant." *Speeches*, 1960, Part 1, pp. 94-112.

- SMITH, Theodore A., Mr.** "Organization and Management." *Speeches*, 1959, Part 1, pp. 33-41.  
 "Organizational Communications." *Speeches*, 1960, Part 2, pp. 173-185.  
 "What Makes an Organization Tick?" *Speeches*, 1958, Part 1, pp. 123-139.
- STEVENS, Edwin L., Prof.** "Conference Techniques." *Management Views*, Vol. VIII, Part 2, 1962-63, pp. 504-532.
- TANK, Charles F., Brig Gen.** "Management of an Industrial Funded Activity." *Management Views*, 1961, pp. 150-161.
- TEELE, Stanley F., Dean.** "Executive Development." *Speeches*, 1957, Part 2, pp. 32-46.
- TRAUB, David W., Lt. Gen.** "Current Highlights in Army Comptrollership." *Management Views*, 1961, pp. 77-91.  
 "Minimum Knowledge of Comptrollership." *Management Views*, 1961-62, pp. 11-26.
- TRUDEAU, Arthur G., Lt. Gen.** "Army Research and Development: One Billion Dollar Business." *Management Views*, 1961-62, pp. 47-59.
- TRUSCOTT, Lucien K., Jr., Gen. (Ret.)** "Leadership." *Speeches*, 1957, Part 1, pp. 154-165.
- TUCKER, R. H., III, Maj. Gen.** "Management at Fort Dix." *Management Views*, 1961-62, pp. 149-165.
- TULLEY, David H., Maj. Gen.** "Leadership." *Speeches*, 1957, Part 1, pp. 178-190.
- UPGREN, Arthur R., Prof.** "Our Depressions Are Getting Smaller." *Speeches*, 1958, Part 1, pp. 140-148.
- VERBECK, William J., Maj. Gen.** "Managing Two Commands." *Management Views*, 1961-62, pp. 239-247.
- VITTRUP, R. L., Lt. Gen.** "Army Manpower and Personnel Management as it is Conducted at the Policy Level in the Department of the Army." *Management Views*, 1961-62, pp. 87-113.
- WATERS, John K., Gen.** "Views on Army Management." *Management Views*, Vol. VIII, Part 1, 1962-63, pp. 9-18.
- WEBER, A. K., Mr.** "Managing Today's Technology." *Speeches*, 1958, Part 2, pp. 119-130.
- WEIBLE, W. L., Lt. Gen.** "Manpower Management." *Speeches*, 1957, Part 1, pp. 146-153.
- WERNETTE, J. Philip, Dr.** "The Outlook for the Dynamic American Economy." *Management Views*, Vol. VIII, Part 2, 1962-63, pp. 533-539.

- WESTMORELAND, William C., Lt. Gen.** "The Challenge of Post Management: Doing More and Better with Less (A Report on Post Management at West Point)." *Management Views*, Vol. VIII, Part 1, 1962-63, pp. 172-201.  
"Management Improvement at the United States Military Academy." *Management Views*, 1961-62, pp. 166-176.
- WESTPHALINGER, Henry R., Maj. Gen.** "Management of Logistics." *Speeches*, 1958, Part 2, pp. 100-109.
- WICKHAM, Kenneth G., Brig. Gen.** "Data Automation and Army Management." *Management Views*, Vol. VIII, Part 1, 1962-63, pp. 202-217.
- WILLIAMS, C. J., Col.** "Management Uses of the Industrial Fund." *Speeches*, 1960, Part 2, pp. 89-103.
- WILLIAMS, Edward T., Lt. Gen.** "Address before second Army Management Orientation Course." *Speeches*, 1959, Part 2, pp. 1-5.
- WILSON, Donald B., Col.** "Review and Analysis at DA." *Speeches*, 1957, Part 1, pp. 102-113.
- WISHART, P. B., Mr.** "Developing Management Skills." *Management Views*, 1961-62, pp. 601-618.
- WOLLE, C. Packard, Mr.** "Plural Management and Research in This Field." *Speeches*, 1959, Part 2, pp. 74-109.
- WOOD, Robert J., Lt. Gen.** "Creative Management at ARADCOM." *Management Views*, 1961-62, pp. 60-86.
- WOOTEN, Sidney C., Maj. Gen.** "Army Command Management System at Fort Dix." *Speeches*, 1960, Part 2, pp. 55-71.  
"Management at Fort Dix." *Management Views*, 1961, pp. 129-149.
- WRIGHT, Moorehead, Mr.** "Integration—A Basic Management Function." *Management Views*, 1961, pp. 321-335.
- ZENGERLE, Joseph C., Jr., Mr.** "The Stock Fund." *Speeches*, 1957, Part 1, pp. 93-101; 1959, Part 1, pp. 77-91 (reprint); 1960, Part 1, pp. 232-246 (reprint); *Management Views*, 1961, pp. 182-198 (reprint); 1961-62, pp. 392-408 (reprint).

SECTION ONE

TOP MANAGEMENT IN THE MILITARY

through the unified commands in the Joint Chiefs of Staff, the dissatisfaction with the handling of problems of materiel and manpower, and the insistence upon the Army Air Corps withdrawing from the Army and become a separate establishment, it was felt in 1947 that we had to take a good look at our defense posture and at our defense organization.

There were two schools of thought at that time. There was the school of thought enunciated by the Department of War — Mr. Stimson's point of view and Secretary Patterson's point of view — that we should have a single unified Department. Now this was not a view that was supported by everybody in the Army but was generally known at that time as the Army view and particularly the view of the Army Air Corps.

The Navy, on the other hand, represented by Mr. Forrestal, was opposed to this. They were for imposing a layer on top, but they wanted that layer to be a coordinating layer.

In this conflict between basically an Army view and a Navy view, the Congress adopted the Navy view.

With the National Security Act of 1947 the Congress set up three departments — an Army, a Navy, and an Air Force. These were Executive Departments. As heads of Executive Departments, their Secretaries were members of the Cabinet and also members of the National Security Council. No Department of Defense was created. Instead these three Executive Departments were together formed into an amorphous body known as the National Military Establishment. At its head was put an official called a Secretary of Defense, who was to exercise general authority, direction, and control. But the statute stated that all powers not specifically given to the Secretary of Defense were reserved to the Secretaries of the three military departments. (See Fig. 1.)

At the same time the Congress gave statutory recognition to the wartime body of the Joint Chiefs of Staff and provided for a separate Joint Staff to assist them. The Joint Chiefs were to be the principal military advisors to the President, the Secretary of Defense, and the National Security Council. Note that they were to be advisors.

At the same time, the Chief of Naval Operations, the Chief of Staff of the Air Force, and the Commandant of the Marine Corps were

---

*Hearings.* In 1950-51 he was Counsel to the National Security Resources Board, and in 1951-53 he was General Counsel to the Reconstruction Finance Corp. In 1954 he was Counsel to the Senate Committee on Government Operations in the Army-McCarthy hearings; and in 1957-60 he was Counsel to the Senate Democratic Policy Committee, the Senate Special Committee on Astronautics and Space, and the Preparedness Investigating Subcommittee of the Senate Armed Services Committee for Missiles and Satellites Investigation. Among his publications is *The Tokyo War Crimes Trial*. He was appointed Asst. Secretary of Defense (Adm.) in July 1964.

(The present paper was presented at USAMS, Fort Belvoir, Virginia, on 4 February 1964.)

THE MANAGEMENT CONCEPT OF  
MR. ROBERT S. McNAMARA,  
THE SECRETARY OF DEFENSE

Honorable  
SOLIS HORWITZ  
Assistant Secretary of Defense (Administration)

The subject which I have been asked to discuss is Mr. McNamara's concept of management, because this is the concept of management which today prevails in the Department of Defense. I hasten to say that I think it is not a concept of management which is unique to Mr. McNamara. I believe it is a concept of management which his predecessor, Mr. Gates, had and I think it is a concept of management that probably most of his successors will have.

*Three Conceivable Roles*

Mr. McNamara himself has stated there are three conceivable roles for a Secretary of Defense. First, the role of the Secretary of Defense can be envisaged as that of a mediator and a coordinator — one who allows his subordinates to work out problems; and then when they cannot agree, tries to get them together to arrive at a coordinated position.

The second role would be really a middle position, a referee's position, a judge's position. In other words, if there is a disagreement, he would resolve it.

The third is the view that the Secretary of Defense is a leader, and that it is his responsibility to take the leadership in management and in the decision-making process.

Mr. McNamara's own view is that the Secretary of Defense must be a leader, that the law imposes this responsibility upon him, and that it would be abnegation of his responsibility to fail to exercise leadership.

*Evolution of DOD*

Let's see the basis for this view: Prior to 1947 we managed our military affairs through two Executive Departments — the Department of War and the Department of the Navy. For various reasons, growing out of World War II, principally the use of joint operations

*Mr. Horwitz is an alumnus of the University of Pittsburgh and the Harvard Law School. His nonmilitary legal career experienced a number of high points upon his release from the Army in 1945. In the period 1945-48 he was Deputy Chief Counsel of the International Prosecution Section of the Supreme Commander Allied Powers for the trial of major Oriental war criminals. In 1949 he was Counsel to the House Armed Services Committee for B-36 Investigation and Strategy and Unification*

LEGISLATIVE DEVELOPMENT

SECRETARY OF DEFENSE	COORDINATOR FOR GENERAL POLICIES			
ARMY, NAVY, AIR FORCE	EXECUTIVE DEPARTMENTS			
STAFF ASSISTANCE	R&D BOARD MUN. BOARD 3 SPEC. ASS'T  JCS (100 OFFICERS)			
	1947			

Fig. 1.

given command over the forces that rested within their respective jurisdictions. Since the days of Elihu Root, the Army did not impose command upon its Chief of Staff. He was given such supervision over the forces of the Army as the Secretary of the Army might direct; command in the Army rested in the Secretary of the Army and, through him, in the Chief of Staff, by virtue of delegation.

Mr. Forrestal worked with this organizational arrangement for just two years; and despite the fact that he was the author, he decided that it wouldn't work — and it couldn't work. He then recommended to President Truman that the Defense establishment return to what had originally been suggested by the civilian leaders, at least, of the Department of the Army.

In 1949 Congress passed the 1949 Amendments to the National Security Act of 1947. (See Fig. 2.)

With the 1949 Amendments, Congress completely altered the picture. It provided for a single Executive Department known as the Department of Defense, to be headed by the Secretary of Defense, who was to be the principal assistant to the President for all matters relating to the Department of Defense. The Departments of Army, Navy, and Air Force ceased to be Executive Departments and became military departments within the single Executive Department. These military departments were required to be separately administered. The Office of the Chairman of the Joint Chiefs of Staff was also created at this time.

In 1953 President Eisenhower, in response to the farewell message of Secretary Lovett, and as a result of the report made by the Rockefeller Committee, sent a Reorganization Plan to Congress. For our purpose in understanding the nature of the Secretary of Defense's job, the details of that plan are not as important as the statements made in President Eisenhower's message to the Congress. (See Fig. 3.)

President Eisenhower said his concept of the Department of Defense was that there was to be no Department of Defense function independent of the Secretary of Defense, and that he regarded the Secretaries of the military departments as operational managers for the Secretary of Defense. So, clearly, he drew a line between policy decision and operational execution.

The next significant organizational change came in 1958, following the Congressional investigation into missiles and satellites, when President Eisenhower proposed legislation for the reform of the Defense Department. (See Fig. 4.)

As a result of the DOD Reorganization Act of 1958, there were two significant additions to the Secretary's power. First, there was increased responsibility given to the Secretary of Defense in connection with military operations. The statute specifically said that

LEGISLATIVE DEVELOPMENT

SECRETARY OF DEFENSE	<del>COORDINATOR FOR GENERAL POLICIES</del>	PRINCIPAL ASS'T TO PRESIDENT FOR DOD		
ARMY, NAVY, AIR FORCE	<del>EXECUTIVE DEPARTMENTS</del>	MILITARY DEPARTMENTS, SEPARATELY ADMINISTERED		
STAFF ASSISTANCE	R&D BOARD MUN. BOARD <del>3 SPEC. ASS'T</del>  JCS <del>(100 OFFICERS)</del>	DEP. SEC. R&D BOARD MUN. BOARD 3 ASS'T SECS.  JCS W/CHAIRMAN (210 OFFICERS)		
	1947	1949		

Fig. 2.

## LEGISLATIVE DEVELOPMENT

SECRETARY OF DEFENSE	COORDINATOR FOR GENERAL POLICIES	PRINCIPAL ASS'T TO PRESIDENT FOR DOD	NO DOD FUNCTION INDEPENDENT OF SEC DEF	
ARMY, NAVY, AIR FORCE	EXECUTIVE DEPARTMENTS	MILITARY DEPARTMENTS SEPARATELY ADMINISTERED	SECRETARIES OF MIL DEPTS AS "OPERATIONAL MANAGERS"	
STAFF ASSISTANCE	R&D BOARD MUN BOARD 3-SPEC ASS'T  JCS (100 OFFICERS)	DEP SEC <del>R&amp;D BOARD</del> <del>MUN BOARD</del> <del>3-ASS'T-SEC</del> JCS W/CHAIRMAN (210 OFFICERS)	DEP SEC  9 ASS'T SECS GEN COUNSEL JCS CHAIRMAN W/INCRP'ASED DUTIES	
	1947	1949	1953	

Fig. 3.

LEGISLATIVE DEVELOPMENT

SECRETARY OF DEFENSE	<del>COORDINATOR FOR GENERAL POLICIES</del>	PRINCIPAL ASS'T TO PRESIDENT FOR DOD	NO DOD FUNCTION INDEPENDENT OF SEC DEF	INCREASED RESPONSIBILITY IN OPERATIONS AND RESEARCH
ARMY, NAVY, AIR FORCE	<del>EXECUTIVE DEPARTMENTS</del>	MILITARY DEPARTMENTS <del>SEPARATELY ADMINISTERED</del>	SECRETARIES OF MIL DEPTS AS "OPERATIONAL MANAGERS"	MILITARY DEPARTMENTS SEPARATELY ORGANIZED
STAFF ASSISTANCE	R&D BOARD MUN BOARD <del>3 SPEC ASS'T</del>  JCS <del>(100 OFFICERS)</del>	DEP SEC <del>R&amp;D BOARD</del> <del>MUN BOARD</del> <del>3 ASS'T SECS</del>  JCS W/CHAIRMAN (210 OFFICERS)	DEP SEC  9 ASS'T SECS GEN COUNSEL JCS CHAIRMAN W/INCREASED DUTIES	DEP SEC DIR DEF R&E  7 ASS'T SECS GEN COUNSEL JCS: OPERATIONAL DIRECTION (400 OFFICERS)
	1947	1949	1953	1958

Fig. 4.

all forces committed to unified and specified commands were responsible to the Secretary of Defense and the President of the United States. In other words, by statute, the Secretary of Defense was put directly in the line of command over the unified and specified commands. The chain of command, by law, was to run directly from the Secretary of Defense to the commanders of the unified and specified commands, who in turn were to exercise full operational command over the forces assigned to them.

At the same time, the Secretary of Defense was given the full authority to centralize control over research and development and to assign new weapons systems for development and operation as he deemed appropriate. There was also a change made with respect to the military departments. They were no longer required to be separately administered, but were to be "separately organized." I have never quite figured out, although I worked with the Senate Armed Services Committee, just what was the intent of this change. I do not know that it was intended to be a weaker phrase than "separately administered," but to just what degree has never been clear.

The command responsibilities of the individual Chiefs were also changed. (See Fig. 5.)

For example, the responsibility of the Chief of the Air Force was altered. Until 1958, the National Security Act provided that under direction of the Secretary of the Air Force, the Chief of Staff exercised command over the United States Air Force.

In 1958 this was changed to read as follows:

"The Chief of Staff shall exercise supervision over such of the members and organizations of the Air Force as the Secretary of the Air Force determines." (See Fig. 6.)

This provision is now identical for the Chief of Naval Operations, the Commandant of the Marine Corps, and the Chief of Staff of the Army.

By statute, the Secretary has command over the unified and specified commands. It is the Secretary, with the approval of the President, who has placed the Chiefs of Staff in their joint capacity in intermediate command between the Secretary and the unified and specified commands. They exercise this authority by virtue of delegation.

### *Legal Authorities of the Secretary*

Now let us examine the legal authorities of the Secretary.

First, the Secretary is the head of an Executive Department. As an Executive Head of a Department, he is authorized to prescribe regulations for the government of his Department and the distribution and performance of its business. This is a power that only Secretaries

THE AUTHORITY OF THE CHIEFS OF SERVICE:

**1947** ...UNDER DIRECTION OF THE SECRETARY OF THE AIR FORCE, THE CHIEF OF STAFF...SHALL EXERCISE COMMAND OVER THE UNITED STATES AIR FORCE AND SHALL BE CHARGED WITH THE DUTY OF CARRYING INTO EXECUTION ALL LAWFUL ORDERS AND DIRECTIONS WHICH MAY BE TRANSMITTED TO HIM

Fig. 5.

## THE AUTHORITY OF THE CHIEFS OF SERVICE:

~~1947~~ ..UNDER DIRECTION OF THE SECRETARY OF THE AIR FORCE, THE CHIEF OF STAFF...SHALL  
1958 EXERCISE COMMAND SUPERVISION OVER THE UNITED STATES AIR FORCE AND SHALL BE CHARGED WITH THE DUTY OF CARRYING INTO EXECUTION ALL LAWFUL ORDERS AND DIRECTIONS WHICH MAY BE TRANSMITTED TO HIM SUCH OF THE MEMBERS AND ORGANIZATIONS OF THE AIR FORCE AS THE SECRETARY OF THE AIR FORCE DETERMINES

Fig. 6.

of Departments possess — the Secretary of Defense and his nine Cabinet colleagues. Other administrative heads of agencies must have specific authority under which to act. (See Fig. 7.)

Second, the statute says the Secretary of Defense shall be the principal assistant to the President in all matters relating to the Department of Defense. This occasioned a General Counsel in 1953 to say: "The Secretary of Defense is thus made the Commander-in-Chief's Deputy." This, I believe, is sound. Whether the rest of that sentence is sound is a matter of construction. It depends on whether the President himself is a military officer in his role as Commander-in-Chief. I don't think it is worth arguing about, but it is true that the Secretary of Defense by statute is made the Commander-in-Chief's Deputy. (See Fig. 8.)

The third of his powers is the direction, authority, and control over the Department of Defense. We hear a great deal about Mr. Vinson's objecting to what the Secretary of Defense does from time to time, but at the time of the 1949 Amendments, this is what Mr. Vinson said he was giving the Secretary of Defense. (See Fig. 9.)

The fourth of these powers is his responsibility for the unified and specified commands. The statute provides that such combatant commands are responsible to the President and the Secretary of Defense for such military missions as may be assigned to them by the Secretary of Defense with the approval of the President. (See Fig. 10.)

It is in the light of these statutory mandates that the Secretary of Defense believes that he is not only responsible for, but that he must exercise leadership in, the Department of Defense.

#### *A Dual Responsibility*

Thus the Secretary of Defense has a dual responsibility, exercised through a dual chain of command. On the one hand he is responsible for directing and controlling the operations of the unified and specified commands; and on the other hand he is responsible for exercising authority, direction, and control over the military departments which provide, train, and equip the forces which go into the unified and specified commands. (See Fig. 11.)

Mr. McNamara therefore believes that he can carry out the responsibilities imposed on him only if he looks upon his function as a leadership function. He exercises an affirmative role in resolving issues and making decisions.

He has certain ways of going about making these decisions and resolving these issues. (See Fig. 12.)

Statutory Authority of the Secretary of Defense

HEAD OF AN EXECUTIVE DEPARTMENT:

"There is hereby established, as an Executive Department of the Government, the Department of Defense, and the Secretary of Defense shall be the head thereof."

--Sec. 201(a), National Security Act of 1947,  
as amended.

"The head of each department is authorized to prescribe regulations...for the government of his department...the distribution and performance of its business..."

--Sec. 22, Title 5, United States Code

Fig. 7.

Statutory Authority of the Secretary of Defense

PRINCIPAL ASSISTANT TO THE PRESIDENT:

"The Secretary of Defense shall be the principal assistant to the President in all matters relating to the Department of Defense..."

--Sec. 202(b), National Security Act  
of 1947, as amended.

"...the Secretary of Defense is thus made the Commander in Chief's Deputy... Under this power...the Secretary of Defense is the highest military officer of the Department."

--Legal opinion of the General  
Counsel, 27 March 1953

Fig. 8.

Statutory Authority of the Secretary of Defense

"The Secretary of Defense shall have direction, authority, and control over the Department of Defense."

--Sec. 202(b), National Security Act of 1947, as amended.

- DIRECTION: "...the act of governing, management, superintends."
- AUTHORITY: "...legal power; a right to command; the right and power of a public officer to require obedience to his order..."
- CONTROL: "...power or authority to manage, to direct, superintend, regulate, direct, govern, administer, or oversee."

Fig. 9.

Statutory Authority of the Secretary of Defense

RESPONSIBLE FOR UNIFIED AND SPECIFIED COMMANDS:

"SUCH COMBATANT COMMANDS ARE RESPONSIBLE TO THE PRESIDENT AND THE SECRETARY OF DEFENSE FOR SUCH MILITARY MISSIONS AS MAY BE ASSIGNED TO THEM BY THE SECRETARY OF DEFENSE, WITH THE APPROVAL OF THE PRESIDENT..."

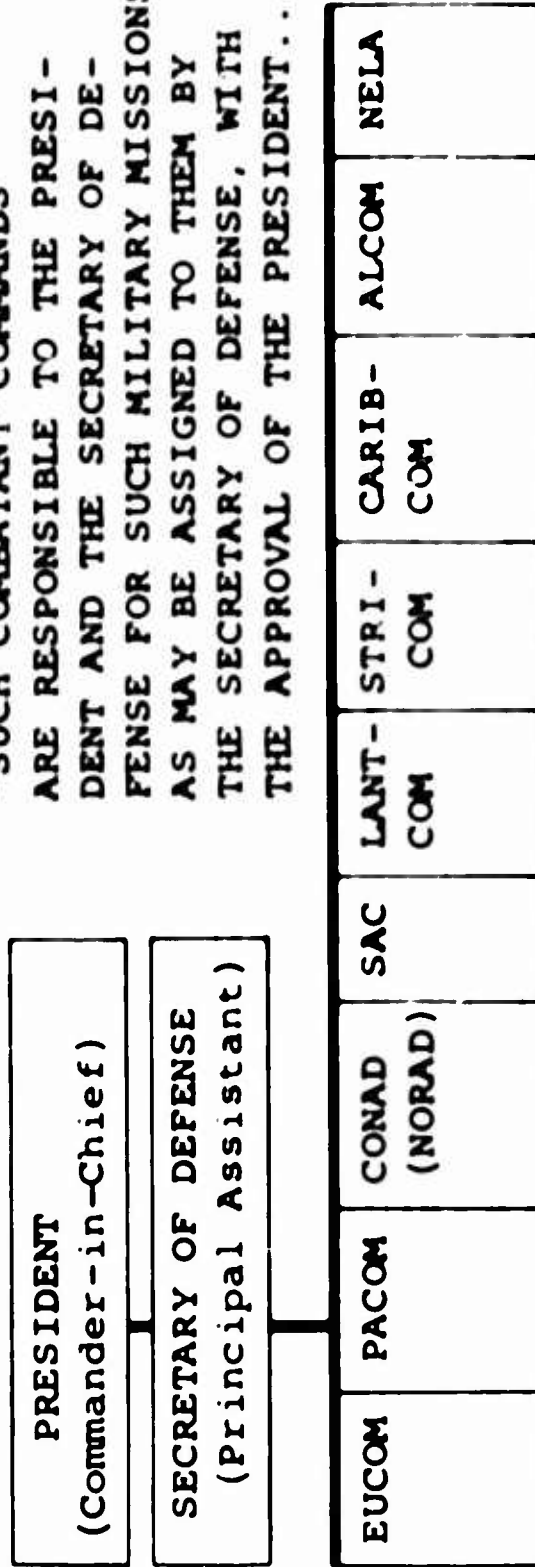

•--Sec 202 (j). National Security Act of 1947, as amended.

Fig. 10.

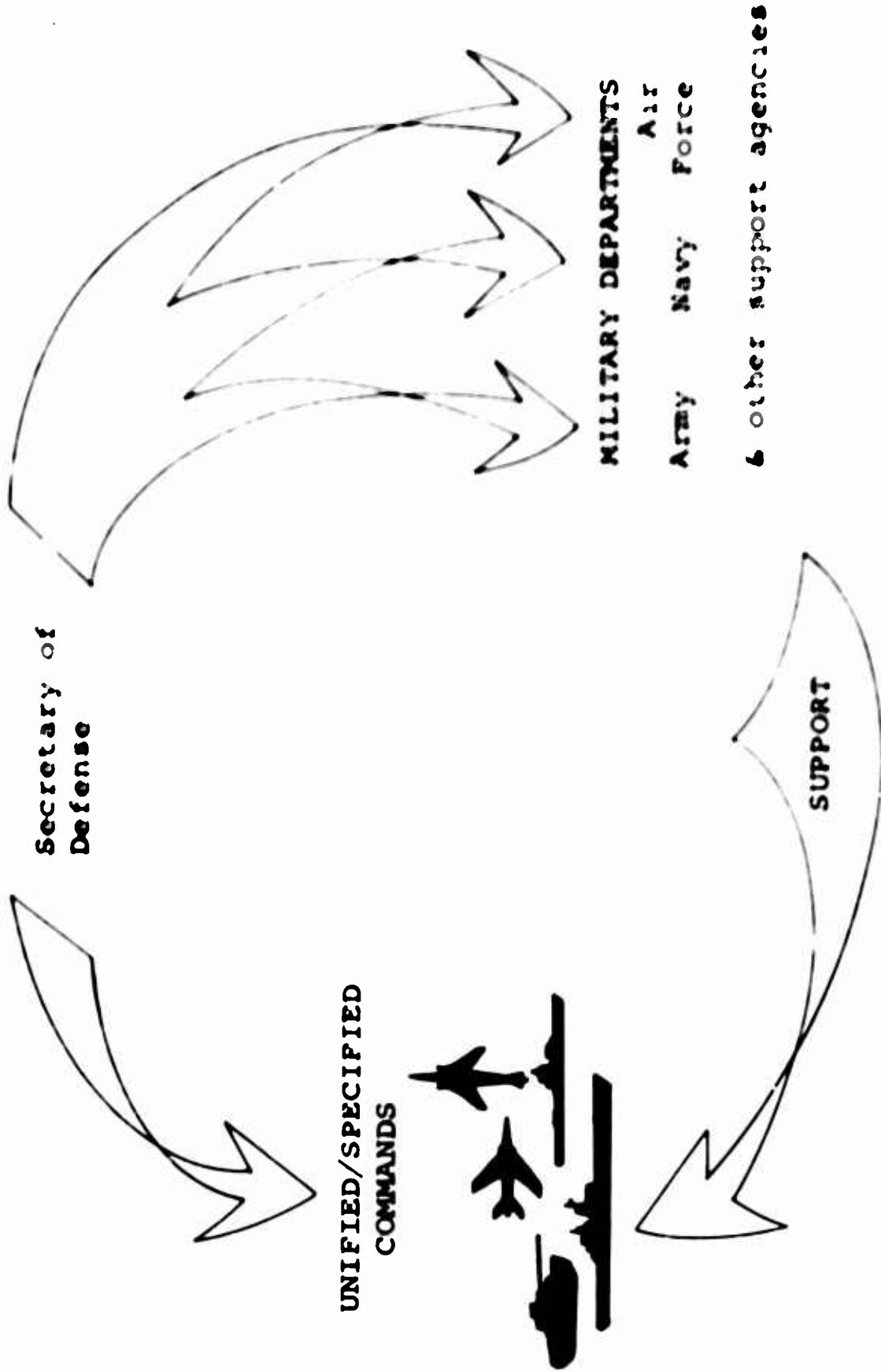

Fig. 11.

**MANAGERIAL DEVICES AND TECHNIQUES**

- **ROLE OF THE SECRETARY OF DEFENSE**
- **THE USE OF ALTERNATIVES**
- **CONCEPT OF DECISIONS**
- **DESIGN OF ORAL BRIEFINGS**
- **SPECIAL PROJECTS**
- **PROGRAMMING AND BUDGETING**
- **FIRM PERSONNEL CEILINGS**
- **CONSOLIDATION AND DELEGATION**
- **RELATIONS WITH PRINCIPAL SUBORDINATES**
- **WORK HABITS**
- **DEADLINES**

Fig. 12.

*Concept of Decisions*

I have already spoken of the role of the Secretary of Defense. I want next to speak of his concept of decisions. Mr. McNamara believes that one of the great difficulties, whether in industry, in the Department of Defense, or in other agencies of government, is the inability and lack of desire to make decisions. If a problem involves conflict, the tendency is not to decide the problem. The tendency is to shove it under the carpet to avoid the conflict; or in the alternative, to arrive at a decision which satisfies everybody. Normally a decision that satisfies everybody probably is not attacking the problem at all.

His concept of decisions is that there are two types of decisions to be made. First of all, there are a host of minor decisions. The important part about these is that they must be made. It really does not make much difference whether most of these decisions are "yes" or "no." They are administrative type decisions. They arise from the type of problems where you should decide that either you are going to do something or not do something and get it over with.

On the other hand there are important problems. Mr. McNamara believes decisions in these areas cannot be left to be solved by the processes of time. They will not solve themselves. As to these problems, he believes they must be thoroughly studied. They must be thoroughly analyzed. They must be subjected to review and every fact brought out — but most importantly, they must be brought to a head. They must be resolved. A decision must be made, and appropriate action must be taken.

In arriving at a decision, Mr. McNamara does not want to be presented with a single staff study that says: Do it this way. He wants a problem analyzed. He wants to know: What are the alternative solutions? This is probably his most important demand on any of his staff: What are the alternatives, including the status quo? And he wants those alternatives looked at. He wants to see the advantages and the disadvantages of each alternative.

Then he wants the various alternatives weighed in terms of their advantages and disadvantages.

Why does he want this? I think this is important, both from the point of view of the decision maker and from the point of view of the staff member.

From the point of view of the decision maker, unless he is given the choice of alternatives, he soon ceases to be the decision maker, because his staff is really making the decisions.

Furthermore, it gives the decision maker, in considering the various alternatives, the assurance that there has been good staff work done, that the problems have been laid out, and that there are no booby traps hidden which have not been brought to the surface.

Incidentally, talking about advantages and disadvantages, Secretary McNamara wants all disadvantages listed even if you don't personally believe that a certain disadvantage is a disadvantage. You can take care of that when you analyze the relative merits of the advantages and disadvantages; but if somebody sees a disadvantage in an approach, he wants that disadvantage listed, then analyzed and weighed.

He is thus assured that he is, one, the decision maker and, two, that he has had good work upon which to base his decisional judgment.

From the point of view of the staff man, it gives him the assurance that he is doing that which his boss needs to have in order to make a decision. There is a great deal of personal satisfaction in making sure that you have presented to your top man the results of a complete and analytical study.

### *Demise of Oral Briefings*

Mr. McNamara likes to see these studies in writing because as a manager he likes to deal not only with generalities but also with detail. By his tremendous grasp of detail, he can weigh the generality. There is no report too long for him to read. He does not care nor does he insist that a report be limited to one page or 20 pages. He wants it to be as long as it needs to be. We have given him reports out of my office that have been 500 pages in length, because this was necessary for the analysis of the problem that he had assigned. He does not generally want to be orally briefed, because he feels oral briefings can only touch the surface of a problem.

When he goes in to discuss a matter with the military Secretaries or the Joint Chiefs of Staff, he wants to be the master of the subject. He expects a similar grasp of the subject on their part.

This demise of oral briefings, I am afraid, has given rise to some criticism about the Secretary not paying too much attention to his military advisors; and sometimes you hear it about his civilian advisors too. It goes back to the fact that we are all human. As a lawyer trying a case in which I was not the principal trial lawyer but was sitting as the assistant at the trial table, I could always think of the questions that my colleague, standing on his feet and questioning the witness, couldn't think of, because I was not under fire at the moment. Similarly, I think many of the officers who used to go in and brief feel that their Chiefs are not presenting the points as well as they would if they were doing the briefing. This is a human reaction. However, I think we are getting away from this criticism. People are now quite aware of the technique that Mr. McNamara uses of acquainting himself with all the details and requiring those who deal with him on the subject to be equally proficient.

Mr. McNamara is not content to allow all problems to come up to him from below. But on the other hand, he feels it his duty to look at the weak spots of the organization and to attempt to correct them. He has adopted the process which we all know well, assigning special projects for investigation and study. One of these special projects was to ask the Secretary of the Army to look at the logistics organization of the Army and whether the Technical Services should be retained. This resulted in the reorganization of the Department of the Army that was approved last year. There have been whole hosts of these special projects.

I have a rather broad charter that enables me to conduct such studies as I think necessary in connection with organization and management of the Department of Defense. I have had this charter for over two years, but I have never once used that power because I cannot keep up with the special projects dealing with organization and management that Mr. McNamara assigns me.

#### *Programing and Budgeting*

Mr. McNamara felt that the Department of Defense needed a new system of programing and budgeting as a management tool. He felt the whole programing system was engaged in a process of treating each of the individual Services with their service responsibilities as a unit. He suspected we were making decisions based on a comparing of apples with oranges; and that instead of getting a good high class type of orange, we were probably getting a somewhat adulterated form of fruit salad. He felt that probably some of the problems that were attendant upon the Department of Defense arose from the fact that we were not looking at our forces functionally. For example, we were making trade-offs between bombers and tactical aircraft in the Air Force rather than making decisions between strategic forces of the Air Force and strategic forces of the Navy.

The result was the institution of the new programing method which is designed to achieve two goals. One, it is designed to produce a functional approach to the analysis of force structure. In other words, we compare and determine our force structure for strategic warfare, regardless of Service. Similarly, we should consider our force structure for air defense as a whole, whether it be Air Force airplane or Army missile type. The second goal is to look at that force structure in terms of total cost over a period of the next five years to give us some idea of what the force structure is going to look like coming down the road and the costs that we are getting into. It is not for us to say, in Mr. McNamara's opinion, that we are buying so many airplanes at such-and-such a cost but he wants to know the total cost of those airplanes throughout their service life. True, they

are going to cost so much; their spare parts are going to cost so much; but in addition, there are associated O&MA and personnel costs that can be identified and these represent part of the total cost of a particular type of force. It is facts like these that Mr. McNamara believes the manager must have in order to make an adequate cost and effectiveness decision, because a relatively inexpensive weapon may demand a very high upkeep which, in the long run, may cost more than an expensive weapon which requires less personnel and has a lower upkeep cost.

#### *Firm Personnel Ceilings*

Mr. McNamara firmly feels that one of the controls he needs is a firm personnel ceilings. While there have been adjustments made and new agencies created, the entire Department has been kept within the personnel ceiling that was originally fixed by him or is annually adjusted. In other words, if he creates an intelligence agency and takes the intelligence functions out of the military departments, adjustments are made so that the total number of people in intelligence remains the same as it was prior to the time the new intelligence agency was created.

#### *Consolidation and Delegation*

Mr. McNamara has a very firm view about consolidation and delegation. One of the problems that he discovered when discussing centralization is that people sometimes don't stop to think what they are talking about. Actually, when we discuss the problem of centralization, there are three different connotations in which we use that word. The first is the centralization of responsibility. In connection with the statute that we are dealing with, there is little question about this. Responsibility is centralized in the Secretary of Defense. However, the other two connotations are more important. We sometimes confuse them. One is the centralization of function, and the other is the centralization of authority.

These two bear a very interesting relationship to each other. I think we can state it almost as a geometrical theorem. The more a function is decentralized or fragmented, the higher the organizational level on which the authority to make a decision must be centralized. Conversely, the more a function is consolidated or centralized, the more the authority to deal with that function can be delegated to a lower level within an organization.

Let me give you a simple illustration with which you are all familiar. Two years ago, shortly after he came into office, Mr. McNamara had a staff meeting in which were present some representa-

tives from the Quartermaster. There were all kinds of belt buckles and all kinds of butchers' smocks lying on the table. There was the Secretary of Defense, mind you, called upon to make a decision as to which belt buckle and which butcher's smock was to be bought. Why? Because the function was fragmented among four military Services, and they couldn't agree. So the question was — the Secretary of Defense had to make his mind up: Would there be a single belt buckle? Would there be a single butcher's smock? If there was going to be one, which one? I think this, more than anything else, convinced Mr. McNamara of the necessity of setting up the Defense Supply Agency with authority to make this type of standardization decision. The net result is that today this function is centralized in the Defense Supply Agency, and the Secretary of Defense no longer decides which belt buckle will be worn. I have news for you: General McNamara (Lieutenant General A. T. McNamara) doesn't either; he has delegated the authority further down in his organization, because he can't be bothered by this type of decision either.

I believe this is the important lesson. Mr. McNamara believes that where a function of this nature is fragmented and the fragmentation is such that it causes problems which require resolution at his level, then it is imperative that that function be consolidated so that this type of decision may be removed from his bailiwick and he can be left with those basic policy decisions that only the Secretary of Defense can make.

#### *Relations with Subordinates*

I have spoken somewhat of his relations with the principal subordinates. Mr. McNamara, first of all, believes that there is a definite limit on the number of people who can report directly to him. He believes that this number at the optimum is about seven. Unfortunately, the size of the Defense Department does not permit the Secretary of Defense to limit it to seven, because there are three Secretaries of military departments and five Chiefs, and that is eight before you get to anybody else in the organization. But he believes that the number must be kept as few as possible. He believes that he must work closely with his principal assistants; he must meet with them; he must discuss his problems with them. He expects his principal subordinates to be experts in those areas which he has entrusted to them, and to give him their advice. He expects them to be as fully qualified to discuss the problem as he is, and I have already told you he does his homework. Let me say that if you have done your homework and are familiar with the facts, he is not a difficult man to convince. He is willing to buy a reasonable point of view that can be supported. But he will not buy general statements, guesses, or

estimates. He will not buy if he feels that his subordinate has not the mastery of the subject that he believes his subordinate should have. As a matter of fact, one of his techniques is that if he does not get from a subordinate what he needs, he will not hesitate to turn to someone else to get it, if he needs that information to make his decision.

#### *Work Habits*

As to his work habits, Mr. Gilpatric said, "... maybe part of our problems are due to the ETA at which Mr. McNamara enters the building." He is there at 7:15. He works from 7:15 until about 7:15. He spends almost every minute of the time either in conference or at his desk reading. When he came into office, he found that there were at least five big meetings that he had to attend every week, like the Armed Forces Policy Council, his Staff Meeting, his meeting with the JCS, and his meeting with the Secretaries. He also had one or two others regularly scheduled. To keep his workload down, he compressed this schedule into two meetings per week. One meeting is the Armed Forces Policy Council, which takes place on Monday morning. But the Armed Forces Policy Council is augmented by all of his principal assistants. It includes the Service Secretaries, the Chiefs, the Director of Defense Research and Engineering, the Assistant Secretaries of Defense, and his special assistants. On Monday afternoon, he and Mr. Vance meet with the Chiefs on wholly military matters.

#### *Deadlines*

Another technique that is associated with Mr. McNamara's special projects, and particularly with his concept of decisions, has been his use of deadlines. As I pointed out earlier, one of our difficulties in assigning a problem in the Pentagon has been the sending down of a problem and then never seeing the answer because people couldn't agree on the answer. The purpose of the deadline is not only to hurry up the work, but also to shift the burden of proof. In other words, if you send work down without a deadline, maybe you don't get it. On the other hand, if you send it down with a deadline, people believe either that they will have to meet the deadline or they have to come in and ask for an extension. I have never known Mr. McNamara or Mr. Vance to refuse an extension as long as the person requesting the extension had good ground; but the Secretary believes that he will eventually get a study if the man responsible fixes a subsequent deadline date. So far his belief has been justified.

These are the principal management techniques that he has used

in carrying out his responsibilities. Many of these techniques, I believe, are good for whoever is running the Department of Defense. Some of them I think are indispensable, such as the use of alternatives, the necessity for making a decision, and the programming and budgeting.

Some of these concepts state some rather basic truths, such as consolidation and delegation. Others are personal to Mr. McNamara. Whether you like oral briefings, or whether you want to read, is rather personal, depending on how you are attuned. I know many judges who like to read briefs; and I know many judges who won't read them at all, but prefer to rely upon the oral argument to get their knowledge of the facts.

•

To sum up: Mr. McNamara believes that, by law, he is responsible for running the Department of Defense. He believes that the ultimate decisions must be made by himself based upon the best advice, military and civilian, that he can get. He believes the best advice is that which analyzes the problems fully for him in terms of alternatives and weighs those alternatives. He believes that once the policy decision is made, operations must be carried out by those who are operationally responsible, but they must be carried out in full conformity with the policy decision made.

## SOME REMARKS ON COMPTROLLERSHIP IN TODAY'S ARMY

Lieutenant General  
ROBERT HACKETT  
Comptroller of the Army

I could talk at great length, using all types of statistics. I'd probably get them mixed up if I did; I'd also bore you. I'm quite sure your instructors have already regaled you with details during the past several weeks.

Instead, I would like to give you a word picture in broad terms of some of the things we are presently studying and implementing in order to improve our operations.

### ARMY COMMAND MANAGEMENT SYSTEM

As many of you know, the Army began the development of the Army Command Management System in 1954. The philosophy behind ACMS was to install an improved, integrated Army program and budget management system and thus give more flexibility to installation commanders over that which they had before 1950.

The backbone of ACMS was the integration of programing, budgeting, and accounting. Our goal was to balance operating programs and the required resources throughout the planning, directing, and controlling phases of program management. The integration of programing and budgeting at the operating level, in the absence of a station-level stock fund, required the employment of cost-based operating budgets.

On 1 August 1956, the President signed Public Law 863, which required cost-based budgets to be submitted to the Congress as directed by the President. The Army believed the law would soon be implemented Government-wide and that, with the implementation of our various financial systems under ACMS, the submission of cost-based budgets to higher authority would be a relatively easy thing to accomplish. Unfortunately, everything we planned for under ACMS did not come about. First, cost-based budgets about the Army level did not become a way of life; in fact, the Department of Defense began objecting to the Army's presentation of the Operation and Maintenance

---

*Lieutenant General Hackett began his military career as Second Lieutenant of Field Artillery upon graduation from West Point in 1931. During the initial years he served in such capacities as that of battery commander in artillery units in the U. S. and the Philippines. He was assigned to the U. S. Military Academy first as instructor and then as assistant professor in the period 1940-41. In 1944 he was assigned to G1, U. S. Armed Forces in the Far East, with successive*

Appropriation on a cost basis. Second, the Office of the Secretary of Defense changed its financial management concepts in the early 1960s by the installation of the Department of Defense programing system and thus became much more involved in details at lower levels of command than had been envisioned. Because of this, Headquarters, Department of the Army, was never able to give the installation commanders the flexibility promised them when ACMS was first instituted. Third, with limitations below the appropriation level, the reporting workload of ACMS proved to be most detailed and burdensome.

Finally, the Office, Secretary of Defense, and the Bureau of the Budget continued to insist on data concerning obligations and expenditures at the project level. As early as 17 December 1957, the Army told one of the Congressional committees, "ACMS, which represents the ultimate in the extension of integrated accrual accounting, is burdened by requirements that are not entirely compatible with the concepts of budgeting and accounting on a cost basis. Under this system fund control is exercised at the budget program level. Due to the continuing requirements of the Department of Defense and the Bureau of the Budget for obligation and expenditure data at the project level, however, installations operating under ACMS in the O&M,A appropriation are required to derive such data from costs rather than merely operating accrued costs."

In view of the above, the Army has made certain internal changes during the past few years. First, the accrual costing of Service contracts was changed to a method of costing a contract as of the date the contract was signed. This meant that cost and obligations were identical for all practical purposes under the system. Second, we are now engaged in changing our concept of the stock fund operation. During the period 1951-59 the Army, under the guidance of the DOD, developed and implemented the Army stock fund for financing and managing inventories at all CONUS and overseas depots except Korea and Okinawa.

---

*duty in Australia, New Guinea, and the Southern Philippines. He remained with that headquarters in its new role as General Headquarters, U. S. Armed Forces Pacific, with successive locations in Manila and Tokyo. He contributed to the success of the New Guinea, Southern Philippines, and Luzon campaigns. In 1946 he was assigned to Second Army and in 1948 to the Office of the Comptroller of the Army at the Pentagon. During the next three years he engaged in various phases of financial management, and in 1951 was assigned Special Advisor to the Assistant Secretary of Defense (Comptroller) on international security and economic affairs. He attended the Industrial College of the Armed Forces before being assigned Deputy Comptroller, Hq., U. S. Army Europe. In 1954 he was appointed Comptroller, in which capacity he served until 1957. In the period 1951-57 General Hackett was associated with various studies of the economic impact on member nations of NATO. He was also engaged in negotiations toward rebuilding the military forces of West Germany. After completing assignments in Hawaii, Maine, and New York, he was assigned Director of the Army Budget in August 1962. He was appointed Comptroller of the Army on 20 August 1963.*

*(The present paper was prepared from the transcription of an oral presentation made at USAMS, Fort Belvoir, Virginia, on 23 January 1964.)*

ARMY STOCK FUND

I would like to interject here that there was a darned good reason for starting the Army Stock Fund. At the end of World War II we had billions of dollars of supplies on our shelves. I think this was true of all the Services. Between World War II and Korea our budgetary resources were not sufficient to properly carry out the approved programs. So the Army used up the stocks that were on the shelves. When we entered the Korean conflict we were short reserve stocks. We were in a sorry plight. I know this, because I helped write six budgets in one year to get the stocks that went into supplying our troops in the fighting.

The stock fund was established in order to make the reserve stocks more sacrosanct; and not to be used by the commander without control, but rather to require budgeting for the money necessary to buy the normal operating stocks in order to properly carry out our missions.

We think the stock fund is a good thing. The world-wide general supply financial operations in the stock fund were conducted in accordance with seven charters approved by the DOD and the Bureau of the Budget. Each charter designated the chief of a technical service, such as the Quartermaster General or the Chief of Ordnance, as the operating agency of a specified division of the fund responsible for the financial and supply management of that division at all levels.

This technique was commonly referred to as the "vertical" concept of organization operation and management. Detailed studies of the operations were conducted in 1955 through 1957, and it was concluded that the vertical extension below the CONUS depot level was disadvantageous and cumbersome. Some of the significant disadvantages found were, first, the chief of technical service as the operating agency for the chartered stock fund divisions was charged with the responsibility for managing the financial and supply aspects of stock fund operations in CONUS Class I and major overseas areas. This responsibility extended across "command lines" and was concluded to be, at best, somewhat inefficient and nonresponsive to the commander.

Second, the technical service supply officers occupying staff and operating positions at CONUS Class I installations and in the overseas commands were placed in the position of protecting the interests of both the stock fund division and the command. Too often this was not possible, due to the differing desires of the two or more commands concerned.

Third, the capability of moving supplies between inventory supply points on a nonreimbursable (interbranch transfer) basis caused stockage levels in the overseas depots, and at some CONUS installations, to be built up unnecessarily in order to assure an adequate

supply at that particular installation. This tied up inventories, caused severe imbalances in the world-wide supply system, and also caused unnecessary expenditures of stock fund cash to procure materiel to sustain the CONUS depot system.

Such expenditures of stock fund cash caused severe shortages of stock fund obligational authority required of commands to finance the procurement of nonstockage items and severely impaired the routine forecast procurement during the fourth quarter of each fiscal year. The accounting and reporting workload required for each of the 14 separate branch offices established was also a major disadvantage. These systems used were not always compatible with each other, which still further complicated matters.

#### COMMAND CHANNEL STOCK FUND

Due to these findings, the Army staff concluded that there should be no further extension of stock fund operations under the "vertical" concept. Instead, we were authorized to initiate a test of stock fund operations under the "command channel," or, as we call it, the "horizontal" concept, beginning on 1 July 1959. This would place the stocks and the stock fund directly under the commander of the installation. This concept provides for a separate division to be established, operated, and managed by a major CONUS or overseas commander within command channels. The assignment of stock fund responsibilities could be then performed in the same manner as all other missions and assignments. This included all responsibilities related to the financial and supply management of inventories on hand and on order for delivery to each installation and activity within a command.

For several years the Office of the Secretary of Defense opposed the extension of the command channel stock fund at the operating level. However, in 1962, the Secretary of Defense directed a study to be made to determine the proper use of operating funds and stock funds. He raised several critical questions, one of which concerned "the appropriate points in the organizational structure where budget centers for operating funds and stock funds should be located." The Office of the Comptroller of the Army and the Office of the Assistant Secretary of the Army (Financial Management) made an all-out effort to secure acceptance of the principles of consumer funding and command channel stock funds at the operating level. These efforts were successful, and these concepts were formally sanctioned by the DOD on 30 March 1963 in a letter written by the Deputy Secretary of Defense to the Comptroller General of the United States. In this letter he stated, "All Services will be required to extend the stock fund to depot level for the items properly stock-funded. Extension

below the depot level will be permitted on an optional basis, provided consistent practices are followed within a military Service. This is permitted in recognition of differences in organization and command relationships within the military Services."

The Army Staff took immediate steps to advise all commands of the Secretary of Defense's approval of the command channel concept and to implement the plan for completion on or about 1 July 1964. As regards the present status of the extension of the command channel stock fund operation, in the USCONARC division 28 Class I installations were successfully established as branch offices on 1 July 1963. These were in addition to nine previously established within Third Army on a test basis. The approved plan called for 34 more to be capitalized on 1 January 1964. Actually, 33 of these were capitalized on or before 1 January 1964.

The extension effective on 1 July 1963 and 1 January 1964 also included applicable inventories at 23 smaller Class I installations and activities which are satellited on some one of the larger Class I installations for logistical and accounting support. This phase of the extension program is not completely implemented.

The approved plan called for three sub-home offices for the U. S. Army Materiel Command division, at the Test and Evaluation Command, the Supply and Maintenance Command, and the Surgeon General's Office; and for branches at each major Class II installation and hospital.

As of the present time, all operating stocks at the Army Materiel Command are still scheduled to be capitalized within that installation division by 1 July 1964. Insofar as the U. S. Army Pacific division is concerned, the approved plan calls for capitalization of stocks and depots, storage locations, sales commissaries, and clothing stores in Hawaii, Japan, Okinawa, and Korea. On 1 January 1964, the inventories of the U. S. Army Materiel Command and the medical-dental vertical divisions in Hawaii and Japan, as well as Operation and Maintenance, Army and Military Personnel, Army inventories in commissaries and sales stores of the U. S. Army Pacific division were converted to command channel operation.

A second phase is now scheduled for 1 July 1964 in Okinawa and Korea, bringing in clothing, subsistence, POL, and allied products, general supplies, and mobility support categories of materiel. The final phase is tentatively planned for 1 October 1964, to include all inventories of the remaining 13 categories of materiel in Okinawa and Korea depots.

In accordance with current understanding it is now planned to convert to the U. S. Army Europe division by 1 July 1964 all vertical stock fund inventories which are in communications zone depots. On

1 October 1964, all inventories in 65 commissaries and 28 clothing sales stores will be brought under the U. S. Army Europe division.

Final plans for the administrations of the remaining inventories, those belonging to Seventh Army and installation stocks at the European Command property accounts, are still to be worked out.

We intend, and I am very intent on this, however, to place the smallest possible workload on the Army itself. We do not want combat troops to be mixed up in accounting for stocks if we can help it.

The plans for establishing the U. S. Army Alaska division prescribe a date of 1 July 1964 for capitalization of present vertical-division stocks and all appropriation-financed inventories. A Department of Army team is scheduled to visit U. S. Army Alaska in March 1964 to assist the command with technical aspects of the implementation. Finally, the U. S. Army Southern Command division is scheduled for operation on 1 July 1964. It will include all present vertical division stocks and appropriation-financed inventories.

The new command channel stock fund operation will require the attention of the installation commander to insure that inventories are responsive to the needs of the installation. He, the installation commander, can no longer complain about the technical services not being responsive to his needs. He must, rather, see to it that his stock fund has on hand the items required to carry out his mission. If this is done, the system will be most responsive to the needs of the installation commander and will permit the maximum utilization of funds for those programs for which they were budgeted. We will not have millions of dollars tied up in undelivered orders at the end of each year, as we have had in the past.

Two years ago the Department of the Army had some \$57 million tied up in undelivered orders from the stock fund. The DOD took \$37 million out of the next year's budget, on the basis that the still undelivered orders should be used to finance the next year's operations. While this had merit, the resultant program was somewhat unbalanced.

#### BUDGET SYSTEM CHANGES

Now we come to the budget system. We are planning to change two fundamental features of the budget process. The first of these changes is a conversion from cost-based budgets to obligation-based budgets. The second change consists of a reduction in and simplification of the reporting requirements imposed on the field for data to be used in budget management. When the command channel stock fund has been fully extended to all operating levels, costs and obligations will be synonymous for supplies and equipment requisitioned from the station stock fund. One will requisition something, have it issued, and pay for it at that time; we will not have a complicated

accounting system for items that may not be delivered for the next six months. As I observed earlier, the accrual-costing of contracts has already been eliminated. Accordingly, we will automatically be on an obligation-based budget when the stock fund becomes fully extended at station level. However, that condition will not obtain fully until 1966, but it was decided to go on the obligation basis for Operation and Maintenance of the Army in FY 1965.

The 1965 budget estimate was formulated by the Department of Army staff and submitted to the Office, Secretary of Defense, on an obligation, not cost, basis. The preparation of the 1965 apportionment request next spring on an obligation basis and subsequent operations in 1965 on the same basis will present some problems.

We were faced with two choices in the manner of development of obligation data for budget formulation and execution. One choice was the continuation of a cost system at installations with the new techniques initiated at Department of the Army Headquarters in order to convert cost data from the field to obligations. The other choice was a full conversion to obligation data for all performance accounts at all echelons of the Army. The latter option has been selected because not only will it be more in the line with the thinking of the Secretary of Defense and the Congress, but it also will place the computations at that level having the best capability of conversion, that is, the man who is doing the job in the field.

Under present conditions, there are several advantages of going to an obligation-based budget. We will be using data that are more understandable to higher authority, and the controversial differences between costs and obligations will be eliminated. The improved communications should, therefore, reduce some of the past difficulties in justifying budget requirements.

The use of obligations for budgeting will provide compatibility between data presented in the DOD program system and corresponding data in the budget. These two have not been comparable in the past. One has been on a cost basis and the other on an obligation basis. This step and others being taken will result in an improved relationship between the Army's program and budget systems.

The budget cycle process of the Army, from installation level to the Department of the Army, will also be simplified under the new system. Much of the involved technicalities of these will be eliminated, resulting, we hope, in making the budget less of a mystery to the commander. If the commander knows what the budget is all about, he can handle much better the job he is doing on the post. If he doesn't know, he's at a loss. If he doesn't really know what's going on.

The second and main feature of the budget system being changed is the execution phase of the budget formulation and execution cycle.

Our present system requires a number of cost and performance reports from the major commands during each current fiscal year. These reports were established to provide the data from the field that were considered necessary for the Department of the Army staff in the management of the budget. However, in our recent reviews of the existing systems, we have concluded that the timing of these reports is such that much effort is being wasted. The first-quarter report is based on insufficient experience due to the shortness of preparation time. The second-quarter report is based on sufficient experience data but arrives too late in the year for it to have any real effect on the operation. The third-quarter report cannot be evaluated before the year is over. And the fourth-quarter report is historical.

Last year I abolished the third-quarter report when I was Director of the Army Budget. I threw out the fourth-quarter report except for a few historical facts, and it didn't harm one person's capabilities one iota except perhaps for some of the imbeciled personnel who were afraid the change would affect their job descriptions.

Each of these reports to a certain extent duplicates information contained in the fiscal reports. We are therefore considering eliminating the first-, second-, and third-quarter cost and performance reports and changing the timing on a new second-quarter report to be known as the Budget Execution Review report. The report will contain four months of actual experience. This will have data on fund use for all funds used for all operations in maintenance of Army activities, plus projections for two months to indicate an expected position at the end of the six-month period. The report will also contain projections for the last six months of the year to reflect the anticipated fund requirements for the entire year. It is further contemplated that the report will be due at Department of Army headquarters by 1 January for use in the mid-year review. The date 1 February has been thought of as the completion date of the review.

This will mean that the mid-year adjustments to the annual funding program will reach the major commands approximately seven to eight weeks earlier than in the past. Capability of the commands to react to the adjustment should be much improved. The fact that only one review, made at mid-year, will be utilized for changing the annual funding program will not, I am sure, inhibit the commander from requesting other changes that he may deem essentials.

#### IMPROVING PLANNING, PROGRAMING, AND BUDGETING

There are also several other actions being taken by the DA which should improve our planning, programing, and budgeting system. On 13 November 1963 the Chief of Staff appointed a steering committee to (a) provide overall direction and guidance to Army

staff agencies in the development of improvements to the programing and budgeting systems; (b) prescribe the priority of effort by the staff on specific subprojects; (c) through the chairman, inform the Chief of Staff periodically of progress in this project.

I am chairman of this committee; I have representation from the Director of Army Programs, the Deputy Chief of Staff for Logistics, and the Assistant Chief of Staff for Force Development. One of the main problems facing this steering committee is how to provide the Office, Secretary of Defense, with the information they desire on DOD program elements, yet not have a duplicate or excessive reporting system placed on the field.

You can tell by the actions I have already taken as Comptroller of the Army that I am very sensitive to excessive reporting requirements.

Our committee is proceeding on the concept that Headquarters, DA, will provide information to Office, Secretary of Defense, from existing reports, statistical samples, and the use of factoring insofar as feasible. A limited number of accounts will, however, need to be added to what we receive from the field. It was desired earlier by certain elements in the DA that we put the programing system down to posts, camps, and stations. This would have meant still another system in the field, another system to keep track of funds and programs, and another system to be reported on. However, by some modification of the grouping of accounts in what we already have, we can make our present accounts conform to the Office, Secretary of Defense, program structure.

Early in February, the field will receive a new Army Regulation (AR 1-11-5), the revised Army management structure, which will include these changes. These are minor changes; later there will be other changes as we closely integrate together the programing and the budgeting. Next we are combining the Army fiscal code and the Army management structure into one document. I have been concerned with the duplication in the two documents for some time, particularly when I find the two responsible elements in my own shop issuing conflicting instructions to the field. A single document will correct this. We're combining the two documents and we're going to name it the Army Program, Budget and Fiscal Structure. It will be the one accounting structure for the whole thing — programing, budgeting, and fiscal. We will issue it by 1 July 1964.

[Note: AR 37-100, entitled "Financial Administration, The Army Management Structure (Fiscal Code)," was issued 15 June 1964. Change No. 1 contains O&M,A Budget Program 2300. - Ed.]

Don't get the idea that we are destroying all the concepts that we have established in recent years. That is certainly not the case. Of the six objectives of the Army Command Management System, as stated in AR 11-45, only one will be eliminated, that is, development

of cost-based budgets. Budgets will now be obligation-based rather than cost-based. The rest of the concepts are still there, but we have simplified the system, cut down on the amount of reporting, and avoided additional duplication in the field by not placing the program system down to that level.

The improvements we have made in the past to integrate budget, programming, and accounting remain. We hope to keep the best from our current system and gain by reducing the workload and providing fund adjustments once a year, early enough to be of value. We think that, once the adjustments are made, the installations and major command will be the ones to benefit.

#### AUDIT COMPLIANCE

My next topic concerns audit compliance. I would like to begin by talking about the various audit programs affecting the Army. I realize that this whole talk is slanted to the Army, and I realize we have other Services here, but I assure you that the other Services are all affected by what I am now going to talk about.

I would like to begin by talking about the various audit programs affecting the Army. First is the external audit program conducted by the General Accounting Office; second is the internal audit program conducted by the Army Audit Agency; third consists of the internal review programs conducted by commands, installations, and activities throughout the Army. This latter internal review includes the audit of nonappropriated funds. I shall not discuss further the internal review program of the subordinate commands and installations of the Army except to say that I certainly endorse all measures by a commander to affect efficient, economical programs and to avoid critical findings by the General Accounting Office or the Army Audit Agency.

#### GENERAL ACCOUNTING OFFICE

Let me first speak about the General Accounting Office. This is an agency of the Congress headed by the Comptroller General of the United States. Its authority derives from acts of Congress passed in 1921 and 1950, and it reports directly to the Congress. The GAO interprets its authority to permit auditing of any activity affecting or requiring the use of Government funds. This, to me, means that they can audit anything they desire. So, to those of you who have not been exposed to GAO audit and think of it only as a review of finances, you have a rude awakening coming. The Marines had a rude awakening recently on a couple of major units; the Army had one on its aircraft in connection with getting ready for Cuba.

The GAO reviews everything from combat readiness to the purchase of excess supplies. The scope of the usual GAO office audit may extend to all aspects of internal or management control and may include the procurement and evaluation of information concerning the history, purposes, authorities, organizations, activities, policies, and procedures of an agency, together with a review of its operating results. Many of you have probably seen the issue of the *Army-Navy-Air Force Journal and Register* which in a front-page article highlighted the so-called intrusion of the GAO into the subject of combat readiness. The article describes the severe criticism of the combat readiness of the 3d Marine Division in Okinawa, and states that the Marine Corps had accepted the GAO recommendations and placed them into effect with vigor. The magazine predicted a growing rapport between the Services and the GAO and said, further, that the GAO will "continue to cover fields which in the past have been thought to be the sole domain of the military experts."

#### U. S. ARMY AUDIT AGENCY

The second major audit program is the one conducted by the U. S. Army Audit Agency. This agency is a Class II activity under the supervision of the Comptroller of the Army. Its genesis is found in Office, Secretary of Defense, directives which require each Service to create a single audit agency answering to the Comptroller.

The Army Audit Agency performs audits of commands, installations, and activities. In addition, it audits contracts and contractor operations. It also performs lateral audits, that is, examinations of a single function or activity at various levels of operation and or in several different locations. An example was a world-wide audit of the control and utilization of Conex containers. In this audit the Army Audit Agency looked into Conex container management in connection with other audits being conducted at various locations. It then consolidated the findings to produce an evaluation.

For the purpose of this discussion, I intend to concentrate my remarks on the audits of commands and installations rather than across-the-board ones. Inevitably questions are raised in relation to the duplication which may exist between the General Accounting Office and Army Audit Agency. It is true that there has been duplication, but usually the GAO avoids duplicating the Army's auditing, particularly when our own auditing is effective. A review has been made of the last 100 reports of audits made by the GAO of Army activities. Findings in the logistics areas cited deficiencies in supply management, inventory excesses, overconsumption of requirements, illegal use of operation and maintenance funds, unnecessary procurement, etc. The findings in the operations area pertain

mainly to deficiencies in aviation operations and combat readiness. Reported conditions in the personnel area alleged unjustified cost-of-living allowances, unnecessary costs for maintaining separate hospital facilities, and malassignments of personnel. Comptroller area reports pertain to stock funds and to leasing vs. buying automatic data-processing equipment. But one of the most disheartening revelations of the analysis of the 100 GAO reports was that, significantly, 31 incidents of similar findings were previously reported by the Army Audit Agency. In some cases these had occurred at the same location. The other Services are having the same troubles.

If proper follow-up and corrective action had been made when inefficiencies were first reported by the Army Audit Agency, there might have been no GAO findings and none of the unfavorable publicity which usually follows on the heels of a GAO report.

I cited the Conex container case as an example of a later audit by the Army Audit Agency. Just the other day we received a draft report on the Conex container audit made by the GAO which might not have been made had we completely corrected the conditions reported by the Army Audit Agency.

Some of you may conclude from these duplications that the audit agencies are passing information back and forth. They do. From time to time the GAO will request copies of audit reports made by the Army Audit Agency. They may also review the work papers at the audit site. However, if they are satisfied with the adequacy of the Army's own examination, and particularly with the responses and follow-up corrective action of the Army, the GAO will go no further. There are also instances where conditions have been reported to have been corrected, whereas the next audit discloses they have not been. A charitable view of this situation is to excuse it as carelessness or oversight. Whether it is that or just plain dishonesty is immaterial; it cannot be tolerated.

#### AUDIT COMPLIANCE GROUP

As a consequence of these difficulties, an Audit Compliance Group has been established in my immediate office. It is a relatively small group with a specific function of providing a focal point in the DA staff for insuring that appropriate action is taken on both General Accounting Office and Army Audit Agency audits. I would like to emphasize that the action taken must be appropriate, because this group looks at both sides of the coin. On occasion the auditors of the Army Audit Agency have been found to be in error or have been overruled. In addition, we have succeeded in getting several GAO audit reports withdrawn.

I should like to say that the timing of the establishment of the Audit Compliance Group was fortuitous in that it preceded recognition by the Office, Secretary of Defense, of the difficulties I have mentioned. That Office has issued some strongly worded instructions designated or designed to improve the response to audit reports. One of these memoranda speaks of "disciplinary action in regard to those seeking to avoid responsibility through dishonest or improper responses to criticism and recommendations."

#### A CLOSER LOOK AT GAO AUDITS

I would like to go back and speak in more detail of the GAO audit. The General Accounting Office, like the Army Audit Agency, performs a variety of audits, including contract and civilian pay audits. But for the purposes of this discussion, I think it is in the area of comprehensive audit that most of you will become involved. Until recently, the GAO audited installations very much like the Army Audit Agency does today. However, they now more frequently select an activity, function, or weapon system and dig into it in great depth and detail either in one area or at selected locations all over the world. A recently issued draft report on aviation operations in Vietnam is an example of an audit of an activity at a single location. The current conduct of audits of combat and combat-support vehicles and the utilization of family housing on a world-wide basis is an example of the present approach.

The vehicle audit is particularly interesting in that it begins at the Army Tank Automotive Center, which is the initial procurement source of vehicles as well as the required spare parts. The audit then examines the activity through the entire system down to the using units at Class I installations both in the continental United States and overseas. Some of the other audits being undertaken now by the GAO are: impairment of combat readiness (1st and 2d Armored Divisions); additional costs being incurred due to failure to standardize combat boots; excessive weights claimed by Army personnel for shipments of professional books, papers, and equipment; improper utilization of trained enlisted personnel; the Hawk air defense system in Korea; the Reserve Officers' Training Corps; and commissary stores.

I could list hundreds of inefficiencies found by the two audit agencies, some of them unbelievably stupid, and some of them the growth of the tremendous size of our business today. Many of them are the result of our own systems established for emergency responsiveness rather than for peacetime economy. But the necessity for peacetime economy is mandatory and extends into all fields, including combat readiness. Many feel, I know, that GAO auditors have no

business in the field of combat readiness. Let me read from the verbatim transcript of an exit conference with the GAO.

The auditor: "I think it might be important to mention here that the General Accounting Office did not perform these inspections. We were provided people from your organizations who were excellently qualified to apply your standards to these vehicles. Our people were merely witnesses."

Assistant division commander: "I am not arguing with the criteria at this point, but I do feel that to say 57% of our vehicles are noncombat serviceable is stretching a point."

Auditor: "General, I would like to make a comment on that. In the first place, we have not intended to say that 57% of your vehicles are not serviceable. We intended only to say your inspectors are applying the criteria which has been given to them by the Army, determining that 57% of those which they looked at did not meet the test."

I emphasize that they are using *our* criteria and *our* inspectors to determine *our* combat readiness. We certainly cannot dispute their competence to record what we tell them.

Let me say something further about the GAO. Increasingly we find in their reports such recommendations as "indicate disciplinary action as appropriate," as well as "evaluation of the efficiency ratings of the personnel responsible." I know there is no one in this room today who is so naive as to ask the question, who are the persons responsible? Each of you will sooner or later have an assignment which will place you in a vulnerable position for future Army Audit Agency or GAO audits. When the reports of the GAO are issued to the Congress, they almost always hit the front pages.

You may remember some of the headlines of the recent past. The "deplorable unreadiness" of the 3d Armored Cavalry Regiment; "\$100 million in overpayments to servicemen"; "Army could be reduced by 2,000 men, with efficient noncombat vehicle maintenance"; "Army depot has 41 years' supply of artillery lamps"; *ad infinitum*. And I could say the same thing for the Navy, the Air Force, the Marine Corps, the Coast Guard.

There will be a new crop of reports hitting the headlines any day now. They seem to conveniently appear just about the time we begin the difficult task of convincing Congress of our need for the funds contained in the annual budget request. I can assure you from personal experience that some of the questions asked by members of Congress last year as a result of GAO reports were extremely difficult to answer. I would agree that frequently the newspaper and other interpretations of GAO reports are unnecessarily slanted toward the sensational. However, regardless of their sensational approach, I can also assure you that the GAO facts are usually right.

#### WHAT CAN BE DONE?

Obviously the answer to our problem in this field lies in eliminating the deficiencies and weaknesses prior to the audit, whether it be made by the Army Audit Agency or the General Accounting Office. We should certainly react constructively to the findings of these agencies, above all the Army Audit Agency, since we at least keep our errors at home if we respond properly to that agency's findings. We do not place the Army in a bad light publicly, provided we expeditiously and efficiently correct the errors. Emphatically, we should cooperate with the personnel of both groups.

No one of us wants waste. We have too many unfinanced requirements. We have just turned the various commands down on 400 million dollars' worth of delayed unfinanced requirements. Corrections on the spot will usually remove criticism from the reports. When the auditors find something wrong, don't waste time making excuses or trying to cover up; instead, immediately take steps to correct the situation, because it will probably be a weakness that should be corrected for the Army's own good. Such cooperation and assistance invariably results in favorable reporting by the auditors.

#### SOME STEPS TAKEN

In closing this portion of my remarks, let me quickly review the steps that have been taken by the DA, at headquarters and in the field, regarding the internal and external audit. The focal point, which I mentioned earlier, the Audit Compliance Group, has been established by the Army Staff for processing both internal and external audits. The Army Staff now approaches both the Army Audit Agency and the GAO audits in the same way, giving equal weight and attention to both. AR 36-6 has recently been published, spelling out all the steps to be taken in connection with Army Audit Agency reports. A revised AR 36-20 has gone to the printer, compiling all instructions relating to general GAO audits. Action has been taken by the DA staff to disseminate on a world-wide basis the findings and conditions reported by both the Army Audit Agency and the General Accounting Office. It is expected that all commands and installations in which similar conditions may exist will take immediate corrective action. Commanders may expect unfavorable reaction by Headquarters, DA, where the findings of earlier audits are repeated, where conditions they have been told to correct are still found uncorrected, where conditions are still found which have been reported as already corrected.

## CIVILIAN PERSONNEL MANAGEMENT PROBLEMS

I'd like to touch upon one other item before concluding my presentation. This concerns the effect of civilian personnel management on the operation and maintenance budget. Civilian personnel costs represent 40.8% of the Operation and Maintenance Appropriation for Fiscal Year 1964. In addition, this percentage is increasing each year. If we take the year 1958 and project it to the 1964 budget, the average civilian salary has risen by more than 40% while the total Operation and Maintenance Appropriation has increased by less than 6%. In addition to increasing salaries, there has been a gradual but persistent grade increase from 6.3 to 7.1%. This looks small, but it represents, at present salary rates, a cost of \$210 per classified civilian employee, or a total of \$43,680,000, just due to grade increases. Indications are that this grade increase is continuing. This may not be wrong, but it's costing money. There have been no reductions in the costs of the employment of indigenous employees. While we have reduced or planned to reduce the man-years by more than 10%, the average salaries have increased by almost 20%. We are now facing an increase in some costs in Korea of 45% in one year. Operation and Maintenance, Army costs overseas have remained almost constant despite our reduction of personnel.

## ANY SOLUTIONS?

The trend cannot continue, or we face having only civilian employees and no supplies and material to properly utilize. What are the prospects for a change? Can we expect substantially larger sums from the Congress? I think not. We're facing an austere period. Can we do with less equipment and fewer supplies? I think not. Can we reduce the wages of our civilian work force? The answer is obviously no. What can we do, then? The only solution is more effective use of our labor force. By this I mean the whole gamut of personnel actions — recruitment of the best people, the most efficient use of people, the retention of only the best people. All of these actions represent areas in which each manager plays a direct and important role. Only by demanding such high standards in our manpower fulfillment can we have true economy. In this respect we should look at the definition of economy as applies to the Defense budget given by the Assistant Secretary of Defense, Charles J. Hitch, in a recent speech.

"Economy in defense does not mean scrimping on essentials, it does not mean buying the cheapest equipment, it does not mean a smaller defense budget. In fact, the defense budget has increased about \$10 billion, or 25%, since this administration took office.

Economy in defense, as we use the term, means getting the most defense capability out of any given level of resources, or, conversely, providing a given level of defense with the given amount of resources. Thus economy in defense is concerned with the efficient use of resources."

Let me cite an example of management problems in the personnel area regarding cost and the consumption of resources. Last year in one command our indigenous hired civilians received a substantial hourly wage increase. This increase had not been anticipated and, consequently, there was no money in the budget to provide for it. The result was insufficient funds to pay the people. A number of possible solutions were available: (1) try to get additional funding while delaying any other action; (2) discharge personnel to get within dollar limits; (3) use some combination of actions involving more money and fewer people.

From the manager's viewpoint and certainly from many others', the least desirable solution is to fire valuable employees. To obtain more money for pay, there were two possible alternatives. The Command could request more money from the DA or reprogram within the command ceilings. From the command standpoint, it was obviously more desirable to obtain additional funds from the DA. At the DA, where a shortage also existed, it appeared to be more desirable for the command to reprogram funds from an activity of lesser priority. In this case some personnel, in all probability, would of necessity have to be fired. The command would reprogram, and the DA would assist with more money.

However, until a situation like this is resolved, matters continue to worsen. My point is that considerable coordination is necessary before a solution can be achieved. Yet this is the very thing that did not happen. The comptroller screamed about his money; the Chief of Personnel protected his valuable employees; and the officer in charge of the TD kept pointing to the authorization. It was a perfect example of an alleged old Army maxim, "When in doubt, run in circles, scream and shout." And that's all they did. They didn't report their problems anywhere and kept the people on the rolls. They were in trouble. An early discharge of employees might have meant a savings for a substantial part of the fiscal year and would have made the absorption of the increased wages easier. On the other hand, with the shortage of skilled labor in the local economy, it is doubtful that employees could ever be rehired if additional funds were obtained. For this reason a mass discharge of indigenous employees was inadvisable. Yet delay only compounded the problem. Each additional pay period the employees were retained meant that still large numbers had to be discharged when it became evident that increased funds were not forthcoming.

## VALUE OF TIMELY COORDINATION OF ACTIONS

I could talk about this particular incident for some time, but I think the point is clear. Whose problem was this? Obviously, it was a multiple staff problem and certainly a case where the comptroller and the personnel officer should have coordinated their actions to arrive at a timely solution. This illustrates another point with which you are probably already familiar but which can always stand repeating. To employ personnel, you must have both an authorization for the manpower and sufficient funds. You have an authorized manpower ceiling of 100, funds that pay . . . — and in effect your ceiling is 90. It doesn't happen quite as often, but sometimes you will find that you have funds to pay more people than your manpower ceiling permits. Manpower ceiling changes or funding changes each have an effect on the balance, and early dissemination of impending changes is mandatory if coordinated action to get the best results is going to be effected. Failure to coordinate promptly may result in failure to effectively use all monetary resources, or, conversely, may require funding at an increasing magnitude proportionate to the delay in coordination and action.

I realize that certain civilian personnel regulations which have been written to protect the employee are both desirable and necessary. But they often complicate the rapid solution of problems. As an example, a requirement to reduce \$10,000 in civilian personnel costs could be easily solved by getting rid of one employee making \$10,000 per year, if you could in fact do this. We all know that eliminating the job does not necessarily get rid of the man. This might be a valuable employee that you want some place else. After bumping and other actions have been taken, it is usually a \$3,000 employee who goes off the payroll. And months later, you're still in the hole. That's not the solution.

Likewise, reductions made at the end of the year are difficult to absorb. Employees must receive proper advance notification and proper placement; replacement actions must be effective. On top of that, the persons finally discharged must be paid earned terminal leave.

You, as managers, must be in on the planning of such matters early in order to insure the least impact on the labor force in effecting the necessary changes. At the same time, managers cannot protect the labor force at the expense of forcing the commanding officer into a violation of statutory requirements to stay within the funding limitations. Early coordinated planning is mandatory if a balanced program is to be established.

Every once in a while things can be really fouled up. Recently a newly organized command's personnel budget was based on improper

average salaries in the face of an end strength greatly reduced from the beginning strength. The improper average salary was further complicated by a much higher grade structure than was originally contemplated. To further complicate the matter, the reduction was of such numbers in certain localities that the Secretary of the Army had to give approval of the actions or face a barrage of inquiries, Congressional and otherwise, to explain the large reduction in force. The decision was made to effect the reductions by a system of normal attrition, with exceptions for key positions. Perhaps if this had been pushed and decided on early in the year, the effect would have been smaller. The information was available in July. The action was started in January. The action was delayed until too late. The result at the end of the year was excess personnel in areas of activities facing a period of de-emphasis and shortages in critical areas of operations. The widespread nature of the command would not permit shifts in personnel. You can wait only so long to resolve the problem, and usually the problem does not go away by itself.

So, again, I must say that timely and effective coordinated planning is the only panacea for the ill. I'm not saying that close coordination within the staff would have eliminated the problem. I am saying that such coordination in a timely manner would have kept the problem as simple as the existing conditions permit. It is virtually impossible to obtain any dollar savings in the current fiscal year on a reduction in force action that takes place in the fourth quarter. Dollar savings from a reduction in force in the third quarter are very small. This means that your planning should be done as early as possible, preferably at the time the budget is being formulated. The information on which such plans can be made is not always available to you at that time, but all too often plans are not made when the information is available in the hope that the problem will go away.

#### MOST FROM THE LEAST

Every indication is that our personnel ceiling in the Army is going to be reduced progressively over the next several years. This is also true for all the Services. The Secretary of Defense and, above all, the President have stated this much. We must do more with fewer people; we must shift people from low to high priority missions; we must constantly increase our productivity.

The Secretary expects the Army, as well as the rest of the Department of Defense, to equal the productivity gains in the civilian economy. You probably remember that a major point was made in this regard with respect to the President's approval of the 1965 budget.

Let us consider briefly the general statements made by the Bureau of the Budget about civilian manpower in its instructions for the preparation and submission of the 1965 budget estimates. These instructions are not really a set of controls, but they might just as well be. The Bureau of the Budget stipulates that civilian manpower estimates for the budget year are to reflect the most efficient utilization. The instructions also require that all estimates for staffing requirements be developed on the assumption that improvement in skills, organization procedures, and supervision will steadily increase employee productivity and at the same time maintain adequate quality. In other words, we must seek to accomplish more with the same people.

When I speak of increasing productivity, I hope it is more effective than one case that was recently told to me.

A certain Navy friend of mine had just finished a course in comptrollership, including work measurements, work simplification, and the like. He was just debarking from a ship at his new station when he saw a man moving wheelbarrows from the dock to a warehouse. He was wheeling them one at a time to the warehouse and walking back empty handed. Seeing a chance to place some of his newly acquired expertise to work, my Naval friend called the man over and said, "Why don't you take a load of wheelbarrows each time? That's what a wheelbarrow is for." The worker allowed that made sense, so he loaded a second wheelbarrow in the first, wheeled the load over to the warehouse, unloaded it, and then wheeled the first wheelbarrow back for another load.

I won't go into internally generated workload vs. the increased productivity in this case, but we could make great strides without such improvements.

Presently of special importance is the fact that where automatic data-processing systems or other new equipment is installed, special gains in employee productivity will ordinarily be budgeted. Thus, if you get automatic data-processing equipment, you should budget for fewer people, not more. Unfortunately, this has not always been followed, for the added capability of the data-processing equipment sometimes results in new evaluations that we have done without since 1775.

Within agencies and commands personnel currently authorized must be utilized to the maximum extent possible in staffing new programs and in expansions of existing programs. A reduced number of personnel should generally be planned where the workload is stable. Estimates of staff requirements for continuing, as well as new, programs are to be based, so far as practicable, on an analysis of the relationships between the number of personnel required and the workload to be performed.

In essence, the Bureau of the Budget demands that you, the manager, obtain the most from the least. And on that note, which I, as Comptroller of the Army, must indorse, I now bring my remarks to a close.

## MANAGEMENT IN THE U. S. AIR FORCE

Lieutenant General

F. A. BOGART

The Comptroller of the Air Force

I would like to talk about Air Force management, in particular. In order to do this, I am going to have to go into organization to some extent, primarily to show you some of our staff and command relationships within the Air Force and some of our major management operations. Then I want to go into things that are currently going on, particularly in the comptroller field, because they cut clear across the Air Force and I am certainly more familiar with these programs than other current ones. Then I will try to show you how we got into these particular programs.

### ORGANIZATION

Basically, the Air Staff is rather a normal type of military staff organization. As shown in Fig. 1, we have across the center level the Deputy Chiefs of Staff. We are of course organized functionally with the Comptroller, Personnel, Programs & Requirements, Plans & Operations, Research & Development, and Systems & Logistics.

Underneath the Deputy Chief level, which is functional, we have specific directors. This directorate level is supposed to be the working level of the Air Staff. As a matter of fact, it pretty much is. At this level each of the deputies is expected to do the decision making which is in his particular bailiwick and where he can do so by having his directors obtain coordination across the staff. We try to keep from the Vice Chief and the Chief any decisions which logically can be made in any one particular area.

I would like to point out certain of these directors. We have the Director of the Budget, the Director of Personnel Planning, and the Director of Aerospace Programs, who is the leading force in getting our Air Force program together and working with the Department of Defense in establishing our program. The Director of Operational Requirements does exactly what his name implies; he also has another very important function I will point out in a moment. The Assistant for R&D Programming and the Assistant for Materiel Programming are also key directors.

*General Bogart received an appointment to West Point in 1927 and a commission as second lieutenant (Coast Artillery) in 1931. After five years of service he entered the Coast Artillery School, where he remained two years. He was then assigned to the Panama Canal Zone. Returning to the U. S. in 1940, he served in North Carolina before being assigned to the War Department General Staff. He worked on logistic planning of overseas operations and was sent to Moscow as logistic planner*

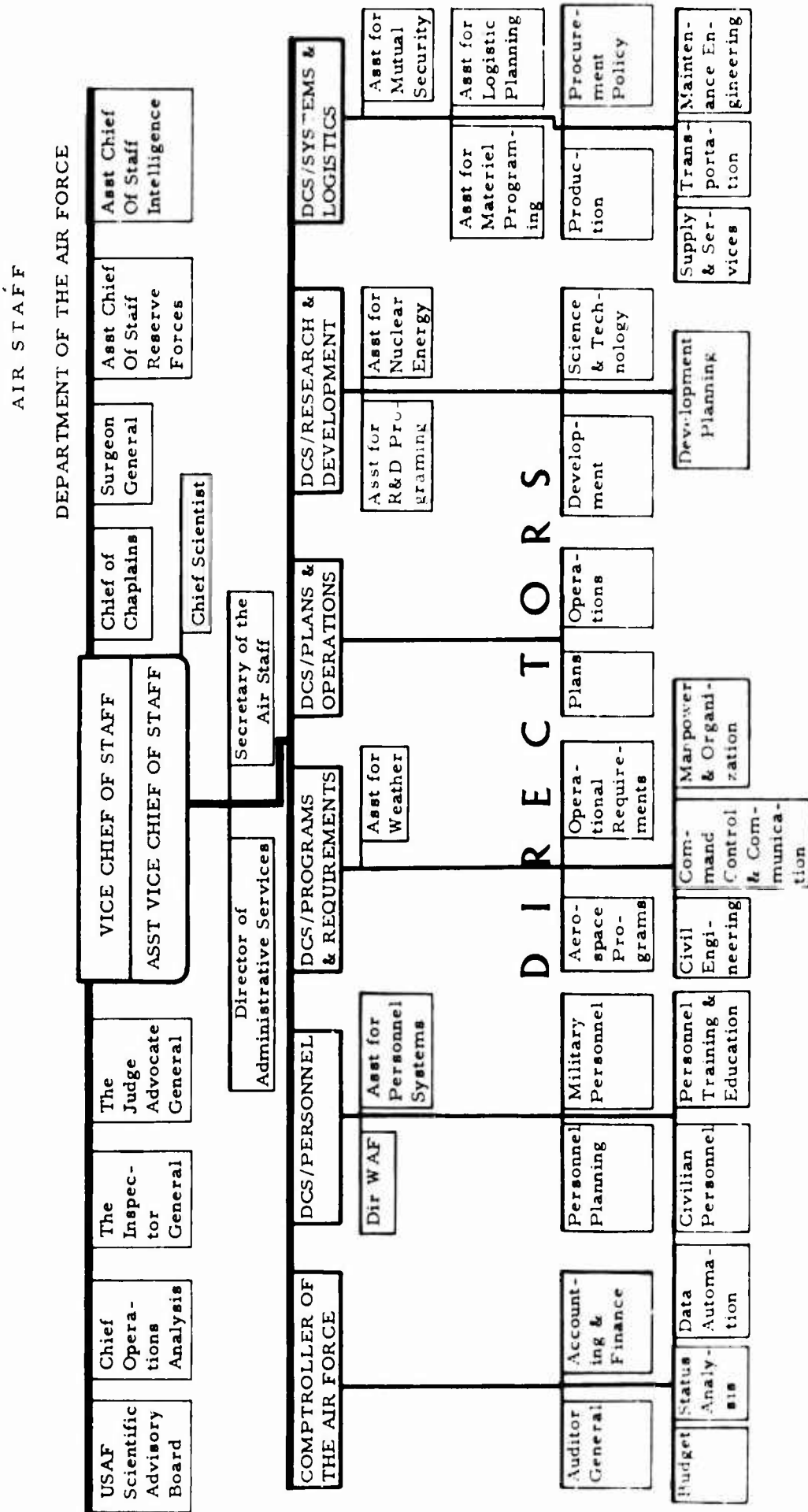

Fig. 1.

The Deputies, together with the Vice Chief of Staff, make up the Air Force Council, which is responsible for recommending to the Chief of Staff all matters of policy and decisions which cannot be made in a specific functional area.

The Air Staff Board (Fig. 2) helps to accomplish our overall development of specific programs, allocate resources, and develop priorities. This board consists of the directors I pointed out previously, with the Director of Operational Requirements as the chairman. These panels, which are permanent and are made up of members at the division level throughout the Air Staff, have the job of sorting out requirements and recommending the allocation of resources within specific areas.

The Force Structure Committee and the Program Review Committee are very important elements of this. The Force Structure Committee is headed by the plans people who recommend to the Air Staff Board what parts of the Force Structure should be particularly beefed up or reduced during any given period. The Program Review Committee has the responsibility of reviewing the allocations of resources against programs and actually making the detailed recommendations to the Air Staff Board.

Obviously, the recommendations that come to the Air Staff Board from these various panels are going to be slanted. So the Air Staff Board, primarily by using the Program Review Committee, attempts to develop a balance across all of these specific areas in making recommendations. It is primarily a matter of developing priorities for utilization of resources available to the Air Force.

The field management of the Air Force is a responsibility of the various commands (Fig. 3). I do not want to dwell on this at all except to point out that all of these operating commands — Strategic Air Command, Air Defense Command, Tactical Air Command, MATS, Air Forces Europe, Air Forces Pacific, and so forth — all of these activities primarily are engaged in the management of operation and maintenance funds that are made available to them by the headquarters. However, Logistics Command and Systems Command have the responsibility for the overall management of the major system resources.

In weapon system management the responsibilities are divided in the following way. The Air Force Systems Command is responsible

*in 1944 for the U. S. Military Mission there. He continued in the logistics field after again returning to the U. S. He transferred to the Air Force in 1947 and his initial service was as Executive Officer for the Deputy Chief of Staff for Materiel. His duties since 1950 have included service in the DOD; Chief of the Plans and Programs Branch of the Logistics Division of SHAPE; Director of Budget; Director of Plans and Programs, AMC; Director of Supply, AMC. On 19 May 1964 he became Comptroller of the Air Force.*

*The present paper was prepared from the transcription of an oral presentation made at USAMS, Fort Belvoir, A. G. on 14 December 1964.*

HQ USAF BOARD STRUCTURE

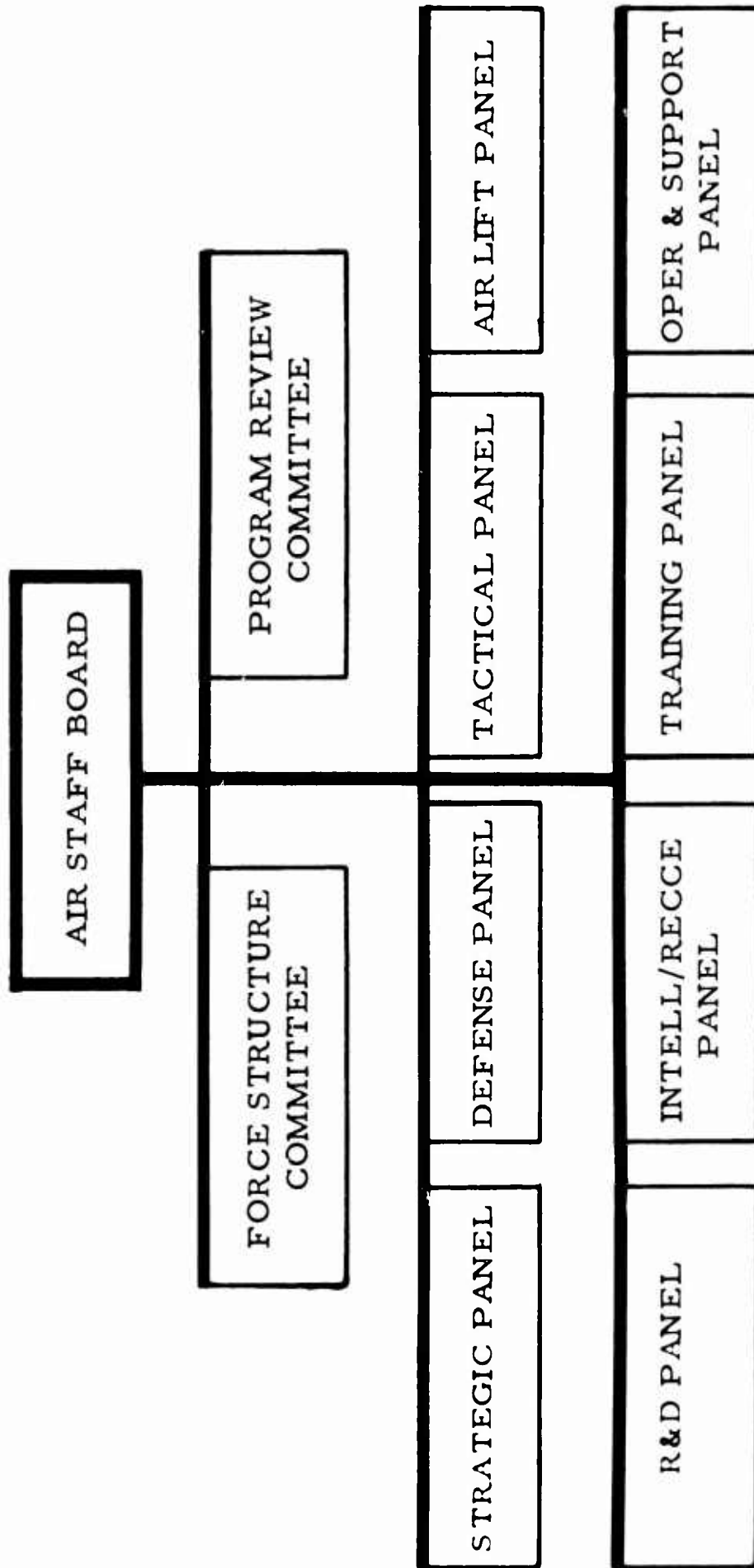

Fig. 2.

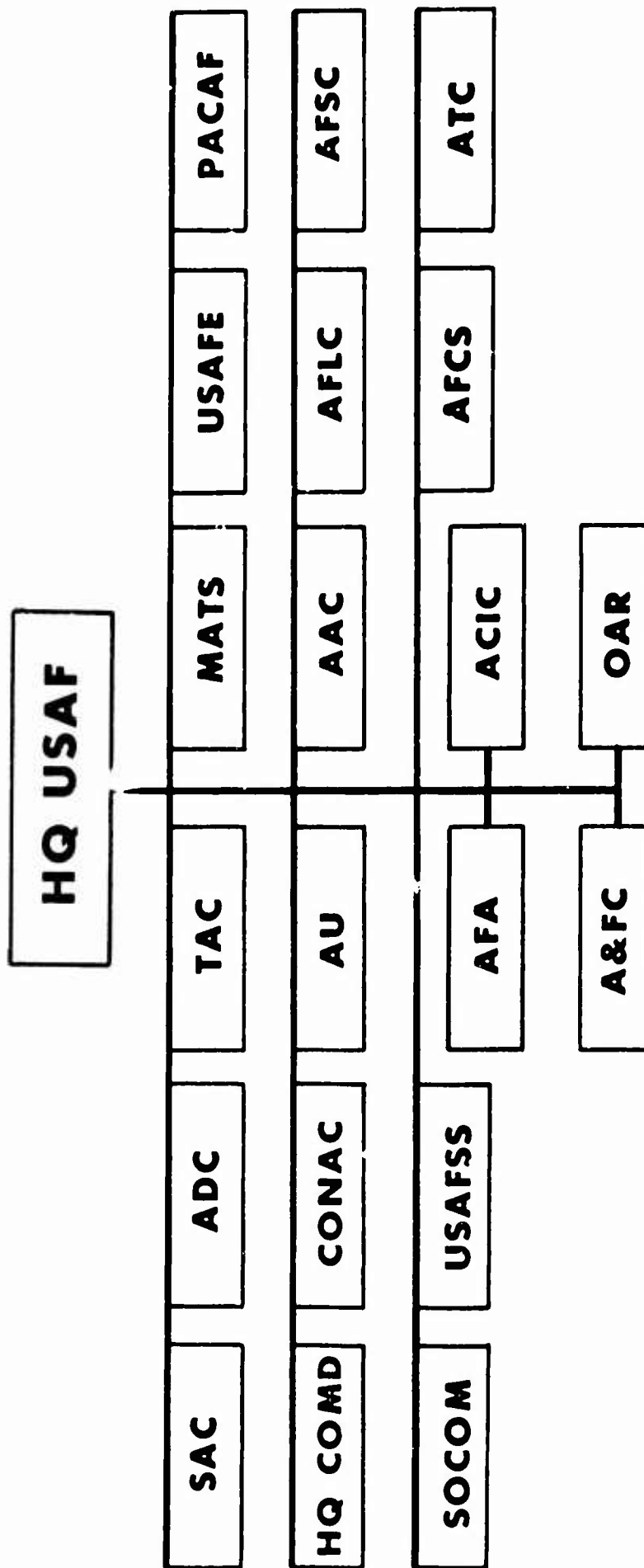

Fig. 3.

for the development of all Air Force weapons systems and for the acquisition phase. The Systems Command is responsible from the time a weapon system is conceived through its development stage until it is purchased and placed in the inventory, at which time the Logistics Command picks up the responsibility for supply, transportation, and maintenance — in other words, for the logistic support of that weapon system throughout its life. The Training Command has the responsibility for training personnel; the Strategic Air Command or other operating command has the responsibility for the operation of that weapon system.

The principal means that are used in the Air Force for the development, acquisition, and later support of an Air Force weapon system — and by this I mean Atlas or Minuteman or the B-52 system — is what we call the SPO (the Systems Project Office). This office is chaired during the development and acquisition phase by an officer from the Systems Command. The Systems Command provides the scientists, engineers, procurement people, etc., and also provides the responsible project officer. However, at the same time, personnel from the Training Command are put into this Systems Project Office to be sure that all the training programs are developed concurrently during the development and acquisition phase. The Logistics Command puts personnel into the Project Office to develop the support systems which will be required and to plan the maintenance and supply systems which will be required to support that weapon system throughout its operating life. And of course at the same time the using command, whichever one it may be (there may be two or three), provides personnel to the Project Office to see that when the weapon system comes out of procurement it is a useable system and that it has the technical data, etc., that are needed. These offices may be very large indeed, as in the case of the Minuteman Project Office or the C141 Project Office, or they may be relatively small. However, at the time that the acquisition phase is finished — and we usually take this at the point where there are no longer any engineering changes to be made on the weapon system. — the Systems Project Office actually becomes a support system office and is commanded by the Logistics Command from then on. It then actually moves to one of the depots.

The Logistics Command, which is responsible for the support of all of our operational weapon systems throughout their operating life, has had for the last decade a philosophy of operating on three basic logistic tools. Everything that has been done in the Logistics Command since about 1952 has been based on utilizing the capabilities of these three things:

(1) Fast, reliable communications. (It started out with punch card communications and is now going into what is known as

AUTODIN, which started out as COMLOGNET, which is fast digital communications and automatic switching.)

(2) Fast, accurate data processing. (The Logistics Command has been developing the use of data-processing equipment with considerable bumps and grinds, as I will explain a little later, since about 1952.)

(3) Responsive land, sea, and air transportation. (I use the word "responsive" advisedly because we do not rely entirely upon air transport. We do have many cases where sea and land transportation are more responsive than air transport. It is purely a question of getting things where they have to be when they have to be there, and of course we cannot afford to use air indiscriminately.)

This management philosophy of the Logistics Command has actually produced results. There is no question about it; it has worked. We have reduced our inventories in the last ten years. As a matter of fact, our spares inventories have been reduced from about 19.5 to 13.5 billion dollars and they are still coming down. We have reduced our pipeline times. For example our pipeline time on engines has been reduced from 45 to 8 days, and this in itself is a terrific saving. When we first went to air transport for engines we took \$960 million out of the engine budget for that one year. That was of course not all at one time, but it was not all a one-time saving, either. It is still coming down.

Our manpower has been cut in the Logistics Command from 225,000 to about 148,000 at present and we have eliminated all of our overseas depots. Of course this has a very immediate effect in producing this reduced inventory. At the same time, our AOCP (Aircraft Out of Commission for Parts) rates have gone down while our supply effectiveness ratings have gone up materially. So this is not theory; it works.

#### SOME COMPTROLLER PROGRAMS

Let us now talk about the comptroller programs for a little while (Fig. 4). These three directors are primarily in the policy and procedures business and are not operators in any sense of the word. The auditor-general is both a policy and procedures man and an operator in that he has a world-wide organization which is outside the normal chain of command within the Air Force. He has, for example, a resident auditor on each base, and he has contract auditors in all of the plants that are producing for the Air Force, and in the Procurement district organization. These people report to the Auditor General. They do *not* report to the local commanders. On the other hand, they are also designated as liaison auditors and operate on the principle of trying to find trouble before it happens and reporting it to the

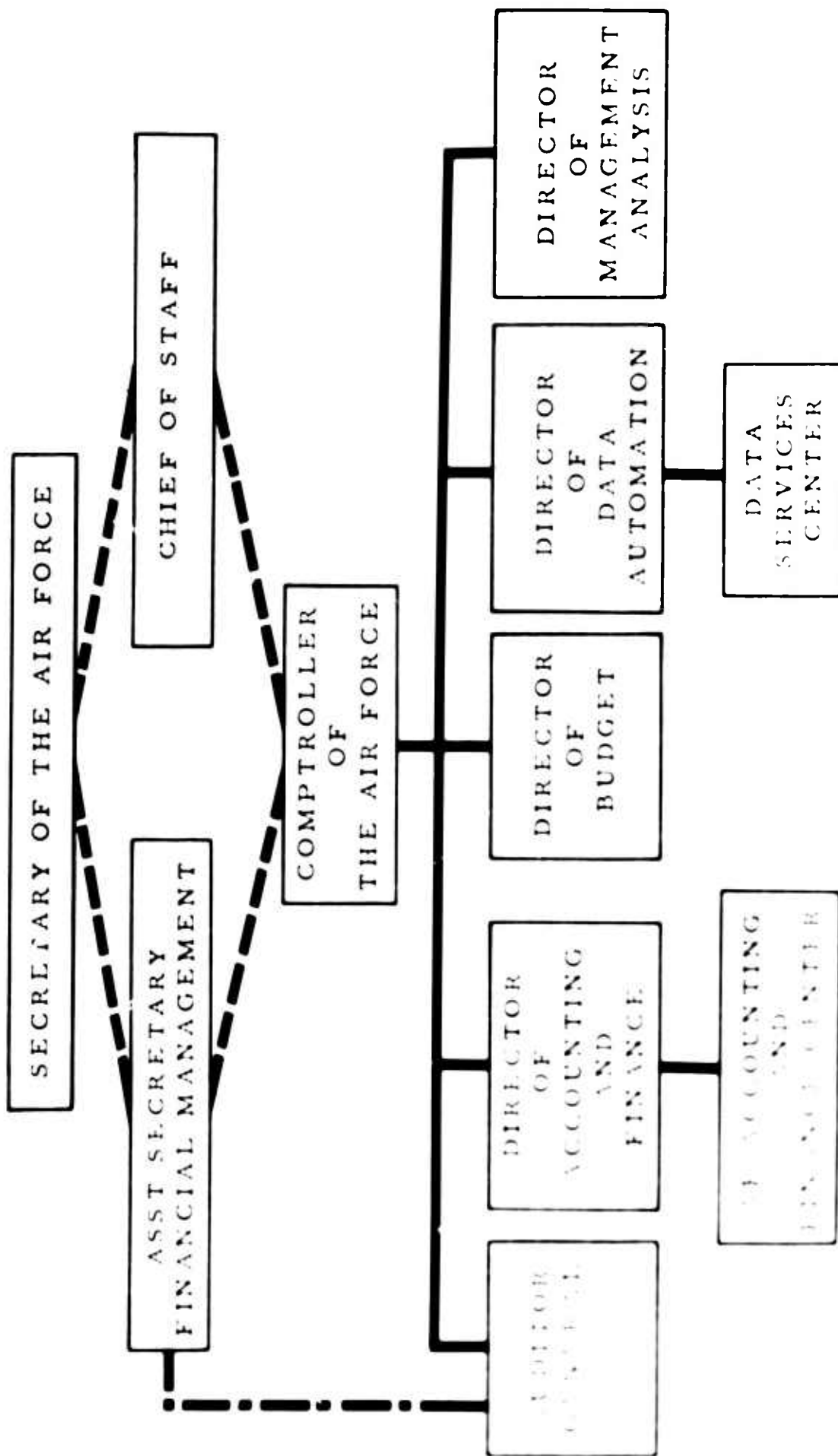

FIG 4

commander. We have had very good success and very good acceptance because of this particular philosophy.

The Accounting and Finance Center at Denver is the field extension reporting in to the headquarters through the Director of Accounting and Finance. The Data Services Center, which is our operating data services outfit for the headquarters, is also a field extension although it is located in the basement of the Pentagon and reports to the Director of Data Automation.

I will talk very briefly about some of the major programs that these people are working on at the present time, and then I will try to show you how we are attempting to control these things.

The Auditor General has in the last few years got what he calls "the Department of New Business" — the precontract audit and cost validation job. Here the auditors, instead of simply auditing the accounts, also take on the job of advising the procurement people on the validity of contractors' submissions. This is precontract work and it has proved very, very valuable because, with their experience in working with contractors and knowing their systems and what previous work has cost, they are able to do a good job in advising the contract negotiators as to the validity of estimates given to them by the contractors. Of course they also have a program to attempt to improve our internal audit. This is pretty difficult because this department of new business has been working pretty hard and we are very short of personnel in the Auditor-General organization. We keep getting new authorizations so that they can pick up more and more of the internal audit and the nonappropriated fund audit, but attempting to schedule this is a little difficult because we keep getting the 1.5% cut, just like everybody else.

We are trying to put more effort into nonappropriated funds mainly because, although the dollar value is relatively small, the morale and welfare value is very, very high and the nuisance value of errors and such things as embezzlement, etc., in this area is terrific.

In Accounting and Finance we have a number of quite interesting programs. Here I am simply going to touch upon some of the specialized programs that these people are working on. The Accrued Military Pay System is now being installed throughout the Air Force; it uses a very small computer, the NCR-390, at base level. There will be about 172 of these computers installed across the Air Force. It will be an absolutely standard system using identical programs all of which are produced at Denver and all of which will be used at every base. This is standardized even to the point where at the finance center we have set up a pegboard for hanging up the program tapes, so that a pay clerk will be able to go from one base to another and find this same tape on the same peg as the base he comes from. This system will give us our first real opportunity to produce accounting

records on military pay on an accrual basis, which was the requirement that was set upon us by Department of Defense one year ago. The DOD established a requirement that we go to an accrued military basis and that we have it operational in Oct. 1964. We had two systems under development, but we had to take this one, the base level system. It is going in on schedule and by July 1964 will be 100% operational across the Air Force.

We were working at the time on what we called IMPACT, a centralized military pay system on which we expect to use a computer at Denver and do all of our military pay from that centralized location. We are doing that now for all of our allotments and all of our retired pay. It is, however, a terrific job to set the thing up and we could not make that date of Oct. 1964. We do not want to keep changing systems all the time, but we said we would go to the base level computerized system. The next step will be IMPACT, or the centralized system, but we will not put that in until three years after we are 100% operational across the Air Force on this one.

LITE is a rather interesting thing. This is legal information through electronic data processing. It is a retrieval system which has been talked about for a considerable period of time. Some of our people in fiscal law at the Accounting and Finance Center have established a project which is now working to develop a computer program and a data base for fiscal law. Strangely enough, we were not going to go ahead and implement this ourselves, but the General Counsel in the Air Force and the General Counsel in DOD and then the GAO (General Accounting Office) and the Bureau of the Budget got so enthusiastic about it that they really forced our hand. We had to go ahead with it this year, even though we did not have the resources to put on it.

We have a very intense program going now in an effort to consolidate and satellite wherever we can in accounting and finance. We have had some success. As you know, there is always an allergy to cutting across command lines on a thing of this sort, but we have found out that a single accounting and finance office can provide good service to more than one type of customer. We are doing this now not only in the military bases but also in the contract area. We have accounting and finance offices in the procurement districts and we have them at many of the larger contractors' plants. Because our communications and our data processing are getting so much better, we have been able, for example, to consolidate six offices in the Los Angeles area into one. We think we have just scratched the surface on this.

Status analysis is quite a unique operation. They do not have exactly the same thing in the Army General Staff. This is what we used to call management analysis and still do in the Field Head-

quarters. At the headquarters the primary job of this directorate is to take a deep look at each one of our major commands and make current status reports to the Chief of Staff. For example, we have just had a report to the Chief on the Tactical Air Command. The Chief of Staff wants this as an Air Staff look at the entire command and does not want it to be the commander's report on this command.

We have teams of specialists who go out; they go clear through the Air Staff, the command, and the command staff and find out how they are doing on combat readiness, how they are making out on their inspections, what their command relationships are, what their problems are, and what their achievements are. Then they put this all together in a report and brief the Deputy Chiefs of Staff. After we get through working on it they brief the Chief. It takes them from four to six months to make up each one of these reports. It has proved to be a very valuable tool for the Chief of Staff. By very careful winnowing out of material they are able to get these down, usually, to about an hour's presentation.

At the moment we also have the additional job of trying to get together a management summary which carries all the information that the Secretary needs regarding the various weapons systems in the Air Force, procurement and development, and of course our fiscal data, personnel data, and so forth. We have been doing this for years, by producing a number of different reports. The Secretary wanted us to try to get it all into one condensed fact book so that he could be aware of the important developments and changes as they occur, in order to keep abreast of all situations.

Also, the Chief of Staff puts out each year a series of very specific chores that he wants to get done throughout the Air Force by the end of the fiscal year. Status analysis is also the reporting activity on that.

I will not discuss the budget in any great detail. However, I do want to mention the fact that we have a major effort going on to get the program package system to a state where we can do as much of it as possible on the computers. Right now we do quite a bit of this. We publish the program and financial base on the computers and also update it on them. We have, for the past 18 months, been developing a management system, a procedure which I maintain is basic to the development of any data system. It will permit us, for example, to take all the program change proposals and bump them against the approved program and financial base to see what effect they will have on each element of the program; to check against the appropriation breaks, as well as the program element breaks; and to see what they do in the way of breaking thresholds and things of that sort. In other words, it will permit us to service-test each one of the program

change proposals before it goes in, and to service-test the alternatives in fiscal and force structure terms so that we know what we are doing when we make a program change proposal, without the tremendous amount of detailed staff computation and coordination that is required at present. It will also give us a capability of taking an approved program change proposal, or one that it approved in part, or one that is slightly modified and cranking it in automatically to up-date our program financial base. By July of next year we expect to be able to have this complete system ready for use in the review of the 1966 budget.

#### COST ANALYSIS

We also have a major effort going on in cost analysis. I do not mean price analysis but the analysis of the cost of new weapon systems which we want to put into development, which are usually pushing the state of the art, and which require very sophisticated pricings as much as seven to ten years in the future. This is a very sophisticated business; as a matter of fact, the only people who were doing much about this were the Rand Corp. Mr. McNamara brought a number of people from that company in on a contract which was called "Rand-Bethesda." It was set up to help with the initial establishment of the program package plan and to go into cost effectiveness studies. He had made a commitment to cut that contract back by 30 June of last year. Last spring we were able to obtain the services of this organization, and we have a plan which will help us to develop an in-house cost analysis capability of this type which will permit us to take state of the art developments, cost them out in a very realistic way, and let us cost full force structures and things of this sort. Also, we will be doing a certain amount of validation of cost effectiveness studies which are a part of the program package system. This is quite a difficult thing, and we think it will be about a three-year program before we will be able to have an in-house capability of this type. With the help of Rand-Bethesda we have set up a school at the Air Force Institute of Technology. The first class goes in on 6 January 1964. This will be a 12-week course and we hope to keep it going continuously until we are pretty well equipped across the Air Force with class one cost analysis of which I am told there are only half a dozen in the country today.

#### DATA AUTOMATION

We have some very significant problems here, and I think I can say we are making some fairly significant progress. Three years ago we completed a study in the Air Force of all of our data automation

processes. We had started back in 1952 in the Logistics Command, then the Air Materiel Command, to develop data automation as a means of assisting primarily in supply management. This got to be a very fascinating business. When I was Director of Plans and Programs at the Air Materiel Command in 1958, part of my job was trying to ride herd on data automation. We found at that time that we had within nine air materiel areas (depots) at least nine different systems for doing the same thing, because we had to start with available equipment and develop means of using it to support our operation. The same thing had happened right across the Air Force; as each one of the commands developed a capability for using computers, to do particular jobs such as scheduling aircraft for the Strategic Air Command, and for MATS, for that matter, they developed their own programs for doing it. But in every case we had always started with the available equipment. We usually were tied to one manufacturer and we had no compatibility. So, after this data automation study was completed three years ago, and after considerable threshing in the Air Council, it was decided that they would give the Comptroller the job of pulling this thing together — of being the focal point of the Air Force. We were directed to take the development away from the field and pull it into the headquarters. The only way that this could be done was to charge the functional areas, that is, each one of the Deputy Chiefs of Staff in the Air Force, with developing his own management system. When I say "developing," I really mean stating his management system in sufficient detail so that it could be translated into a data system which would permit the development of logic diagrams and would then permit the development of specifications for hardware. In other words, starting from a management system, instead of starting from a piece of equipment, and then trying to fit a management system to it. It took a great deal of effort just to get that train turned around as far as thinking was concerned.

We set up a Data Automation Panel with some subpanels for each of the functional areas. We decided that we would set up an evaluation group instead of having each of the Commands attempt to go to industry and get competition for equipment. This is an equipment evaluation group and we set it up in the Electronics Systems Division of the Systems Command near Boston. We set it up there mainly because they had been working with the computers for the Command and Control Systems for years. We decided that we would buy this equipment the same way we buy a weapon system. We would put out specifications to industry after the development of a system, we would complete it, and we would then have this evaluation group review the submissions of all the contractors. We would then have a system selection by a board of general officers exactly the

same way we handle our selections for the procurement of an aircraft or a missile or anything else.

We have had Supply on computers at bases in the Air Force since about 1958. All the Strategic Air Command was on computers, but we had to get more capacity. The first thing we worked on was supply, and we found out immediately that in order to set up a base level supply package and to get specifications for it we had to start all over again in writing out the management system design. In other words, the supply manual for base supply was not adequate to develop a package of specifications for equipment. So we spent a year re-writing that manual and getting instructions in sufficient detail. We finally did come up with a fine set of specifications. As a matter of fact, the major contractors were so enthusiastic about the specifications and they did so much talking about it that the unsuccessful bidders couldn't bleat after we had an evaluation and source selection and selected one contractor to provide 152 computers for the Air Force base supply package. That was a 35-million-dollar jolt to the industry and we now have a standard base package for supply. It will be an identical operation at every base in the Air Force. It will have the identical machine program on it, any machine man or supply clerk will be able to go from one base to another and find the identical supply operation, which is something we have not been able to do to date.

We also have a standard major command computer program which is considerably more difficult. We are not yet quite ready to go for competition on this, but here again, once we get our specifications, we will go to industry on it. We will compete it and it will also be standard, so that any deviations will be local deviations specifically authorized as an addition. There will be no deletions to any part of the command machine program.

In addition to this sort of thing, we have in the Air Force now a plan which is in the initial stages of implementation for centralizing all our military personnel management at Randolph. This is a great departure — taking all of our personnel management out of the headquarters and putting it into a personnel center which will ultimately become part of the Training Command so that it will become a Personnel and Training Command. One of the big jobs here is to get a computerized system which will permit the major portion of this work to be done on computers because of the workload involved and the accuracy required when you do this centrally. We think it will take about three years to complete the implementation. We have now the personnel data system for officers. It is completed and being run on the computers at the Pentagon. As soon as we finish with our facility work at Randolph, we will install the computers there and pull that out of my data center at the Pentagon.

I have been talking about some of the major programs that our directors within the Comptroller are working on. I want to show how we got there, how we got these things set up, and how we track them. We set up a series of basic objectives about 2½ years ago (Fig. 5). These are general objectives and I do not want to dwell on any one of them except to point out that in our overall general objectives we said we wanted to standardize our organizational structure, and to simplify and standardize data accumulation and reporting systems. This is quite important: the elimination of duplicate data sources and reporting channels. If you know anything about accounting and finance, you will know that the worst thing you can do is to have two sources for the same piece of data, because you never can reconcile it. I would much rather be somewhat wrong and be consistent than have two reports on the same thing and not know which one is right. Of course in automatic data processing and communications this is a very general type of thing but it is again simplification and standardization.

Now let me point out certain things that we are trying to do within the Air Force to improve the quality of the data that we are providing. Cost analysis is a specific one. The matter of career development for both military and civilian personnel is also very important. We emphasized the selection of personnel at as early a point as we can for further training. For the ones that we think will ultimately come out on top, we try to line them up so that we get them through the proper schooling and so forth.

This matter of standardization particularly applies to our procedures in accounting and finance and all of our machine activities. We are trying to maintain a capability to provide data back and forth with the other Services and with OSD, and this is quite a problem.

In summary, then, the objectives that we have been working on in the comptroller business, and, for that matter, right across the Air Force, are matters of standardization, simplification, and exploitation of technological advances in communications and data processing with the idea of trying to provide, in the Comptroller's case, more meaningful service to management, because we are a service organization.

By working toward these objectives, we have really reduced equipment requirements. I don't say that we have cut our requirements for EDP equipment in total in the Air Force, because we're still expanding the areas in which we are using them (for example, in the personnel side). But we have been able to reduce requirements and actually to reduce costs in every individual area where we have attacked this on a basis of standardization and simplification of procedures. We have also reduced the requirement for retraining of personnel because we standardized our accounting and finance organization

**OBJECTIVES**

- \* SERVICE TO MANAGEMENT
  - \* PROVIDE APPROPRIATE ACCURATE & TIMELY DATA TO COMMANDERS AND STAFFS AT ALL ECHELONS
- \* ORGANIZATIONAL STRUCTURE
  - \* STANDARDIZE
- \* SYSTEMS DEVELOPMENT
  - \* SIMPLIFY AND STANDARDIZE DATA ACCUMULATION AND REPORTING SYSTEMS; EMPHASIZE ELIMINATION OF DUPLICATE DATA SOURCES AND REPORT CHANNELS
- \* AUTOMATIC DATA PROCESSING AND COMMUNICATIONS
  - \* EXPLOIT EXPANDING POTENTIAL OF DATA PROCESSING AND COMMUNICATIONS TECHNOLOGIES THRU SIMPLIFICATION AND STANDARDIZATION OF DATA ELEMENTS, CODES, PROCEDURES, ETC.

Fig. 5.

and procedures. We do have that standardized across the Air Force bases now. We were losing from three to seven months of each man's time when he was transferred from one command to another. He had to start all over to learn the new command system. He might basically be an accounting and finance clerk or a pay clerk, but he still had to learn different procedures. We have made considerable progress here and have of course made savings in O&M funds. We will ultimately end up here with compatible computer applications. It would be very nice, I guess, if we could just standardize on one manufacturer's computers and put them in clear across the board and do everything on them. However, we do have the problem of competition, so we have adopted the policy of standardization by application. Two good examples are the accrued military pay system on the NCR-390 and the base supply application across the Air Force with 152 Univac equipment (the 1040).

We are now trying to get compatible between bases, within commands, between commands, between commands and the Air Force, and ultimately between the headquarters and other elements of the Department of Defense. One program that we have going on is quite an extensive, long-range effort to get common data elements and codes right across the Air Forces. It should go without saying that if you are going to be automated, if you are going to use computers, you should be using standard data elements and codes or nothing will be compatible. This is quite true, but we have found as many as 33 different codes to refer to the same item of equipment, which happened to be one spare part. We also find in the DOD there are 27 different codes that refer to the Pentagon. Getting these things reduced to a single one with the proper number of digits is quite a chore. We are making material progress. We have almost finished with the materiel side and we are about half way through with personnel. We have still to go into such areas as intelligence and things of that sort. I think this is probably another three-year project.

Basically, then, our philosophy across the Air Force is to set some basic objectives and then milestone the thing and track the milestone. You've got to track it; if you don't track the milestone, it rapidly loses its meaning and you don't get the progress that you expect to get because people forget it.

We make changes or try to make them only when they will increase the effectiveness or economy of our operation, and where we can prove it to ourselves before we do it, because changes, whether they are organizational or procedural, are always disruptive and can cost a lot more than they are worth. So we try to do a very careful cost effectiveness study of any changes we want to make before we decide to implement them.

We try throughout to point out the importance of people in our management systems. It does not make any difference how much you get mechanized or how much you get computerized; unless you have trained and dedicated people, you can't operate your system at all. We work very carefully on our career progression trying to pick the right people for the high slots, to ensure that they are put there at the proper time, and also to be sure that we select the proper people for the various professional schools and that we later track them to see whether their assignments are compatible with the basic education that they have already had.

#### COMMUNICATION

One other point I would like to cover is the matter of communication. I have said that we rely on fast, accurate communications in the Air Force and that the Log Command has built a total system on this; but in this case I am talking about communication between people, with regard to the products of one system or one program against another. For example, I might have issued a supply policy directive when in the Air Materiel Command and found out by going back to Supply nine months later that the item clerks had never heard of it, unless I had specifically directed that it be read in a certain order to certain people. In other words, you have to get the word out.

I would like to give one horrible example of what happened to us with regard to the Automatic Resupply Logistics System, which was developed for support of the ballistic missiles. When we went into the ballistic missile program, we had a theory that this was going to be something quite different from anything done before and that the support of missiles was not even going to resemble the requirements that we had for the aircraft systems. We got together a very talented group of supply people, maintenance people, management people, and some very skilled computer people and locked them up at Norton Air Force Base, which was to be the support base for the first of the ballistic missiles — Atlas and Titan. They developed this system by throwing away the book and starting from scratch. They came up with a very fine product, generally speaking. This went on for four years. At just about the time we went operational, in other words, when we were about to turn over the first flight of three missiles to Strategic Air Command, we put this system on the air. It started grinding out automatic resupply requirements and sending out status reports, inventory data, and configuration data to the inventory managers, who did not know what to do with it. The whole thing broke down. One day we got six dump trucks, took the output of the machine room out of the materiel manager's office, and

ran it over to the incinerator. This was quite a job because most of it was classified. We then had to start some special schools. The funny part of it is that the people who were operating that system from the standpoint of the computers knew exactly what they were doing and the people who had been running supply and maintenance management knew exactly what they were doing, but that neither of them knew what the other was supposed to be doing. For that reason we had to run special schools to train all the supply and maintenance people on what that system was, what it would do. That system is now working like a watch.

We had a breakdown in communications at that point which made the system utterly worthless. So I think probably one of the most important links in our whole management business is communications. This is something that we can never forget.

## PLANNING, PROGRAMING, AND BUDGETING AT DEPARTMENT OF ARMY HEADQUARTERS

Brigadier General  
LEONARD C. SHEA  
Director of Army Programs  
Office of the Chief of Staff

I am pleased to have this opportunity to discuss certain facets of planning, programing, and budgeting, the principal elements of the management process at the Department of the Army through which our objectives are translated into a combat-ready Army. As you know, all three systems have been influenced by innovations introduced by Secretary McNamara which emphasize the importance of developing management procedures that assure the best possible defense posture for the resources expended.

### DIRECTORATE OF ARMY PROGRAMS

I would first like to locate the Office of the Director of Army Programs in the DA Headquarters organization (Fig. 1).

As this figure shows, my office is a part of the Office of the Chief of Staff. I serve as the principal assistant to the Chief of Staff and the Vice Chief of Staff on program matters. In addition, I chair the Program Advisory Committee and am a member of the Budget Advisory Committee. My office serves as the focal point for programing activities on the Army staff, and is the Army point of contact with DOD and the Joint Staff on program actions.

The directorate has two divisions. One, the Coordination and Evaluation Division, handles program change proposals and most of the other day-to-day actions which are assigned to our office. The other, the Plans and Systems Division, is primarily concerned with the overall development, refinement, and procedures of the Army Program System. In other words, they are concerned with the underlying concepts and long-range design of the system.

The Army of course operates within the framework of the DOD integrated management system which is keyed to the three-phase decision-making process of planning, programing, and budgeting.

---

*General Shea entered the U. S. Military Academy in 1932. He was commissioned a second lieutenant, Field Artillery, in 1936. His first assignment was to the 12th Field Artillery, Fort Sam Houston, Texas.*

*Transferring to the Cavalry in 1938, in the period 1938-40 he served in the 5th Cavalry (Fort Clark, Texas); the 3d Infantry Division (Fort Lewis, Washington); and the 9th Cavalry (Fort Riley, Kansas). During World War II he commanded*

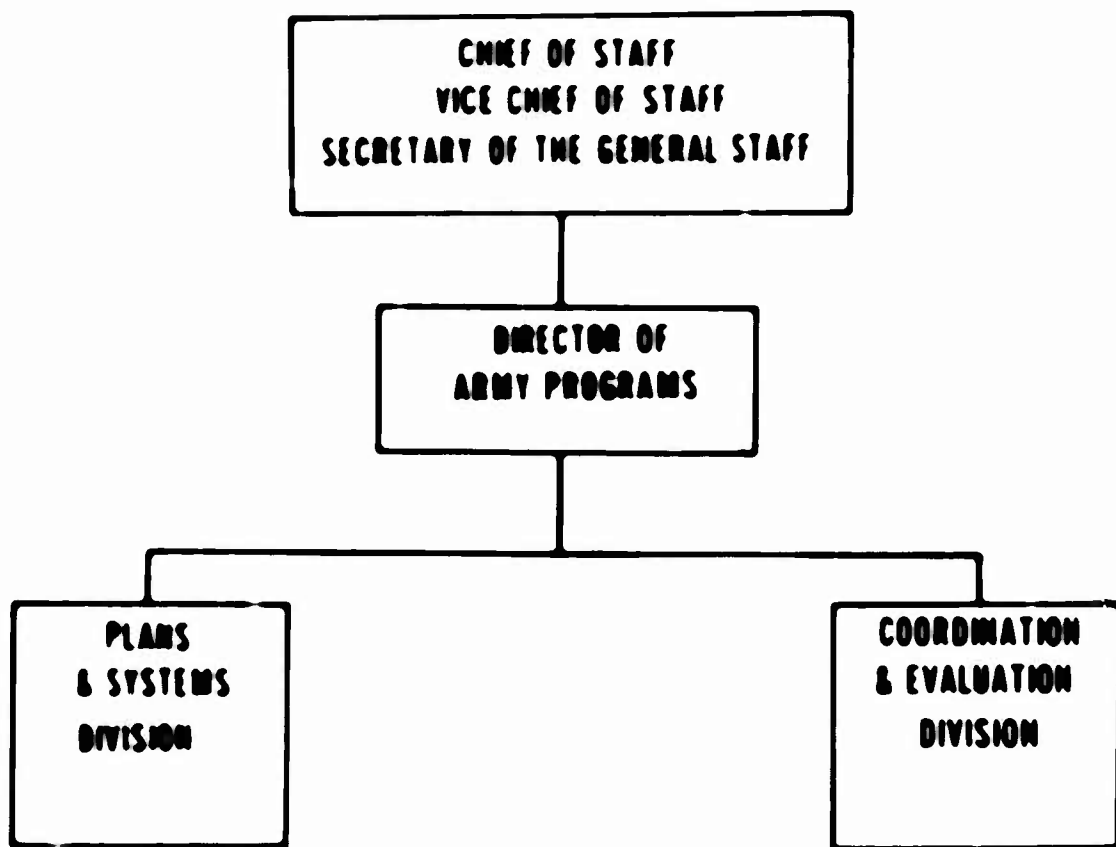

FIG. 1.

This system is designed to tie all facets of the defense effort together, relating national security objectives to strategy, strategy to forces, forces to resources, and resources to costs -- all within the same conceptual framework and all projected several years into the future.

Although much of our current emphasis is on the program phase, I would like to stress that the new programming system in no way changes the importance of the planning activities which precede program development — or the budget activities that occur after the program is approved.

*In the first phase, planning*, we determine strategic objectives and the requirements to meet them. This includes such basic long-range considerations as the nature of future warfare, the role the Army will play in such warfare, the type of equipment and weapons systems that we will need, and the optimum grouping of forces and weapons systems to accomplish the missions assigned. In other words, what we need to do our job.

*In the next phase of the decision process, programming*, we translate our strategic requirements into time-phased courses of action calculated to produce what we need — when and where we need it. This is the phase where we link forces with resources and costs, and secure Secretary of Defense approval of the Army's part of the defense program. Throughout the Services today the standard format for expressing this time-phased course of action is the Five-Year Force Structure and Financial Program, commonly called the Base Program. I will discuss this in some detail later.

*The third distinct phase, budgeting*, is the process by which we obtain legislative approval of the annual segment of the program in terms of appropriated monies and authorizations for strength, major materiel items, and research and development.

---

*the 2d Squadron, 124th Cavalry. In 1944 he attended the Command and General Staff College. Thereafter, until 1946, he was assigned as instructor in the Tactical Department, U. S. Military Academy.*

*His assignments from 1946 to 1950 were: 5th Cavalry, 1st Cavalry Division (Japan); Assistant Director of Instruction, The Armored School (Fort Knox, Kentucky); 82d Reconnaissance Battalion, 2d Armored Division (Fort Hood), Texas.*

*He was assigned as Assistant Chief of Staff, G1, in 1951, and in Germany that same year became Chief of Staff of the 2d Armored Division, which position he held until August 1953. Returning to the U. S., he attended the Armed Forces Staff College until January 1954.*

*In 1954-56 he was assigned to the Army General Staff, serving successively as Chief, Strategic Planning Branch; Chief of Policy Planning Division; and Assistant Director of Plans, Office of the Deputy Chief of Staff, Military Operations. In 1956-57 he attended the National War College.*

*In July 1957 General Shea was assigned to SHAPE, remaining until March 1961 as Chief, NATO Annual Review Branch, and Assistant for Coordination, Programs Division. Upon his return to the U. S. in April 1961 he became Chief of the Estimates and Funding Division, and subsequently Assistant Director of Army Budget for Plans and Operations, Office, Comptroller of the Army.*

*He was assigned as Director, Coordination and Analysis, Office of the Chief of Staff, in December 1962, and became Director of Army Programs on 20 August 1963.*

*(The present paper was presented at USAMS, Fort Belvoir, Virginia, on 3 February 1964.)*

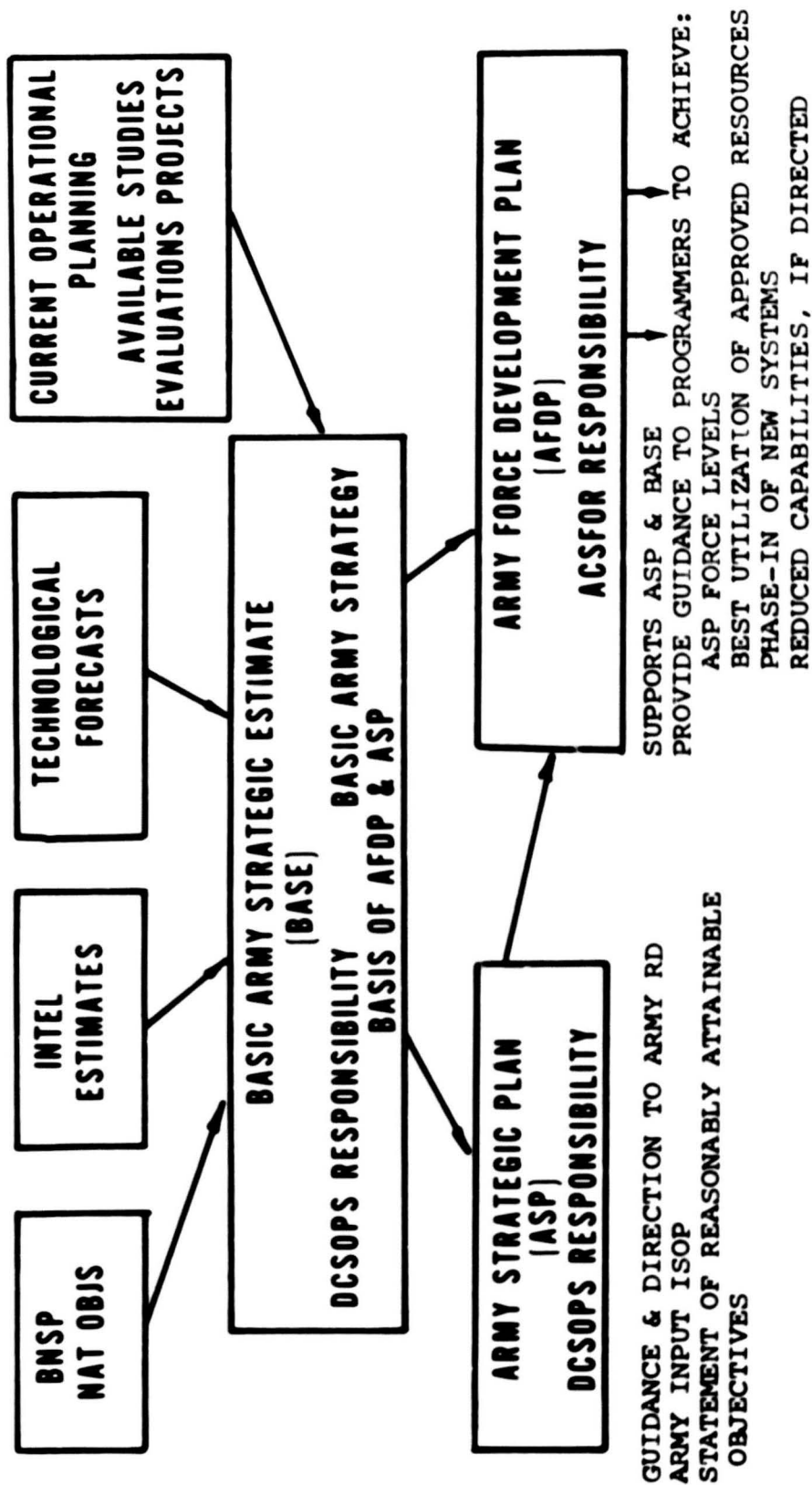

FIG. 2. NEW ARMY PROGRAM FOR PLANNING.

The three phases are closely related, and there is no sharp line of distinction between them.

Under the DOD integrated management system, it is essential that guidance derived from plans be translated into programs, or changes to existing programs, which detail the application of resources by mission area. Thus, refined and approved plans must serve as the evaluated blueprint for program changes. Without such a blueprint, proposed changes to the Base Program on a random choice basis exposes any part of the program to spot decisions promoting imbalances and may lead to a fragmented or "patchwork" end product.

#### ARMY'S NEW FAMILY OF PLANS

Figure 2 shows the Army's new family of plans. They are designed to provide service input into the JSOP (Joint Strategic Objectives Plan) and other plans within the cognizance of the Joint Chiefs of Staff, and to provide the detailed guidance for program development. The time span of the three plans starts with the current year and projects 20 years into the future to satisfy the various needs for guidance. Each plan is to be maintained current, with major updating and extension annually.

The basic document in the new family of plans is called the Basic Army Strategic Estimate or BASE. Some of the source documents utilized in the development of the BASE are shown in the figure. The estimate sets forth pertinent portions of Basic National Security Policy and other policy determinations, provides a technological forecast, evaluates the enemy threat and capabilities to affect the land battle, and outlines the preferred Army strategy to deal with this threat. In effect, it provides a 20-year environmental forecast and is an assessment of the Army's role in that environment. It does not identify force requirements, but does provide broad basic guidance for the Army's R&D effort.

The Strategic Estimate precedes development of the Army Strategic Plan (ASP), a plan directed toward determining in fairly finite terms total Army resources required to support the strategic concept, intelligence estimate, and technological forecast of the BASE. The mid-range part of the ASP (2 to 8 years in the future) serves as a basis for developing Army input to the JSOP. In the longer range time frame (8 to 20 years) it provides more finite guidelines than those in the BASE for the Army research and development effort. The plan takes into account estimates of resource levels that are reasonably attainable in the climate of the times.

The Army Force Development Plan provides us with the essential link between strategic plans and programs. The Force Development Plan does this by providing detailed guidance on future forces in

terms of specific units and associated materiel, requirements for training facilities, construction, R&D, etc. It is constrained by various resource limitations and constitutes the planning basis for revising the Army Five-Year Force Structure and Financial Program. It serves three principal purposes:

First, it is the basis for the development of the best possible Army within the resource levels of the approved program. It identifies shortfalls and attendant risks, and provides alternatives for lessening the risks. This plan analyzes the Army Five-Year Force Structure and Financial Program and identifies those highest priority needs not reflected in the currently approved program.

Second, it sets forth desired incremental and balanced increases in new weapons systems and forces, time phased and in order of priority, and identifies the associated additional resources required to attain planned objectives.

Third, it shows how to best accept incremental decreases in capabilities — in inverse order of criticality — in the event of budget cuts or other unforeseen eventualities.

The fundamental objective of this plan is to assure the best possible use of resources provided to the Army to do its job.

The ultimate result of the planning activities just discussed leads us then to the Army's Five-Year Force Structure and Financial Program — the Base Program.

#### ARMY PROGRAM SYSTEM

The Army Program System is rooted in the system which DOD initiated in early 1961 to satisfy a need for a single integrated information system which would serve to keep top management abreast of the entire current and planned defense program. Its overall purpose was to regularize the decision-making process and to provide for comprehensive evaluation and cost effectiveness analysis. The functional arrangement of the budget into programs such as pay, construction, procurement of equipment, etc., while useful for many purposes, does not focus on forces and capabilities in relation to missions, which have become the key decision-making areas of concern to DOD.

The objectives of the system are:

— To program on a mission-oriented rather than a function-oriented basis, as has been the case in past years.

— To give greater consideration to alternative programs with respect to both cost and effectiveness.

— To extend the time span of DOD-approved programs to five years or more, and thus provide to the Services and DOD agencies the long-range guidance not heretofore available, including total costs

- I STRATEGIC RETALIATORY FORCES
- II CONTINENTAL AIR AND MISSILE DEFENSE FORCES
- III GENERAL-PURPOSE FORCES
- IV AIRLIFT AND SEALIFT
- V RESERVE AND GUARD FORCES
- VI RESEARCH AND DEVELOPMENT
- VII GENERAL SUPPORT
- VIII CIVIL DEFENSE
- IX MILITARY ASSISTANCE

Fig. 3. Programs.

MAJOR PROGRAMS	PROGRAM ELEMENTS
I STRATEGIC RETALIATORY FORCES	B52 B47 POLARIS ATLAS TITAN
II CONTINENTAL AIR & MISSILE DEFENSE FORCES	F102 F106 NIKE HERCULES MISSILE MASTER BOMARC
III GENERAL PURPOSE FORCES	INFANTRY DIVS (BY AREA) REDSTONE BNS (BY AREA) F100 F104 DDE AKA CARRIERS
IV SEALIFT AND AIRLIFT	ARMY PORT TERMINALS C130 C124 MSTs SHIPS BY TYPE
V RESERVE AND GUARD FORCES	NIKE AJAX NIKE HERCULES DIVISION FORCES BRIGADES
VI RESEARCH AND DEVELOPMENT	NIKE ZEUS MISSILE B MAULER PLUTO ASW SEA PLANE
VII GENERAL SUPPORT	RECRUIT TRAINING PROFESSIONAL TRAINING ARSENALS DASA
VIII CIVIL DEFENSE	SHELTER ACQUISITION WARNING CONTROL AND COMMAND

Fig. 4. DOD programs.

of forces and systems over their operational lifetime.

— To develop long-range programs without regard to any fixed budgetary, manpower, or materiel ceilings, with military need as the prime criterion.

— Finally, to make budget recommendations consistent with DOD program decisions. For example, the program for FY 1968 will be continually revised and updated during the next three years as a prelude to its becoming the budget recommendation for FY 1968.

A system based on these objectives promises a dynamic approach toward solving many of the problems which have plagued us in the past. Needless to say, the system is still far from perfect. Although it incorporates no new specialized methods for determining resource requirements, a program developed in the context of these objectives does provide a logical way of portraying requirements in mission terms over an extended time period.

In its present form, the DOD program consists of the nine major programs shown in Fig. 3. These programs reflect the entire defense effort, and being organized on a broad mission purpose basis, they cut across individual Service organizations and functions. Resources to support the broad missions are allocated, on the basis of their relative importance, through the program system. Each of these major programs is composed of many subdivisions called "program elements" which provide a more detailed breakout of the total resources devoted to each program.

Figure 4 shows the relationship of the major programs to the program elements assigned to the Services. A program consists of an interrelated group of program elements, considered together, inasmuch as in aggregate they support a broad specific mission. The important point here is that the unifying principle of each program is a common mission or set of purposes for the elements involved.

A program element is an integrated activity, a combination of men, equipment and facilities which together constitutes an identifiable military capability or support activity contributing to accomplishment of one of the broad missions stated or implied in the title of a major program.

I'll review briefly the Army's participation in these major programs and describe some of the Army's 280 program elements which are of particular interest.

*Program I, Strategic Retaliatory Forces*, is made up primarily of Air Force strategic bomber and missile forces and the Navy's Polaris missile forces. It contains no Army program elements.

*Program II, Continental Air and Missile Defense Forces*, includes all of the active Army's resources devoted to the air defense of CONUS (ARADCOM) as well as certain Air Force and Navy air defense elements. Here the relationship of program elements to

the major mission program is clear: for example, both Nike Hercules and F-106 fighter aircraft clearly contribute to continental air defense.

*Program III, General Purpose Forces*, includes our oversea commands and the CONUS-based Strategic Army Force, certain Marine Corps and Navy fleet activities, and the Air Force tactical air units. This program naturally is of extreme importance to us, and is the largest Army program by far. For any of the five years addressed in the Base Program, it reflects about 50% of the total obligational authority available each year and over two thirds of the military manpower.

*Program IV, Sealift and Airlift Forces*, includes only a few Army ports and terminals, along with the Navy's MSTs ships and the Air Force MATS fleet.

*Program V, Reserve and Guard Forces*, includes all Army Reserve component units in their various readiness categories, as well as the Reserve forces of the other military departments. This program also carries the Army National Guard on-site Nike Hercules battalions.

*Program VI, Research and Development*, encompasses most of the Army and other service major R&D projects.

*Program VII, General Support*, reflects those Army activities not directly related to any specific mission program. Included are such activities as training centers, strategic communications, schools, hospitals, logistical support, and the Army's participation in agencies managed at the joint and defense level.

*Program VIII, Civil Defense*, and *Program IX, Military Assistance Program*, are both prepared at present by the DOD, and there are no specific Army program elements in these programs.

To accommodate the Army's varied forces and missions in a meaningful display, the basic DOD program structure was altered to reflect a geographic break for the Army. (See Fig. 5.) To illustrate this point, this figure shows the program elements for Army Forces, Europe. As far as the Army is concerned, this geographic break is a significant and highly desirable feature because it corresponds to the way we command, plan mission accomplishment, and administer funds, and therefore is the way we need to program. Also, the command to which an Army unit is assigned and its geographic location are essential to any real understanding of the role that a specific unit plays in our strategy. You will note that the manpower and other resources required to sustain these forces on the continent would in effect correspond roughly to the direct Army contribution to U. S. participation in the defense of Western Europe.

For these and other reasons, the assignment of program elements to a particular geographic area in Program III is peculiar to the Army.

COMBATANT FORCES

INFANTRY DIVISIONS	REDSTONE BATTALIONS
ARMORED DIVISIONS	CORPORAL BATTALIONS
AIRBORNE DIVISIONS	SERGEANT BATTALIONS
MECHANIZED DIVISIONS	LA CROSSE BATTALIONS
PROVISIONAL AIR MOBILE UNITS	PERSHING BATTALIONS
BRIGADES	MISSILE COMMANDS
NIKE HERCULES BATTALIONS	SPECIAL FORCES
HAWK BATTALIONS	AVIATION COMPANIES
HONEST JOHN BATTALIONS	OTHER COMBAT FORCES
LITTLE JOHN BATTALIONS	COMBAT SUPPORT UNITS

COMMAND AND SUPPORT FORCES

LOGISTICAL AND SUPPORT FORCES  
ADMINISTRATIVE AND COMMAND FORCES  
SUPPORT TO NON-ARMY AGENCIES

Fig. 5. Army general-purpose forces, world-wide.

Each program element in the structure is represented in the program documentation by a Descriptive Data Sheet which describes in layman's language the purpose of the element and its composition, and by a "cost," or Program Element Summary Data Sheet, which contains pertinent financial and manpower data. The Descriptive Data Sheet identifies the element by title and its code. Other information on the sheet concerns some of the missions and related tasks which you might expect an airborne division to perform. Also shown are some examples of force composition, strengths of selected units, and some major items of equipment. The descriptive sheet, in essence, provides a thumbnail sketch of an airborne division.

The Program Element Summary Data Sheet also identifies the element by name and code. It displays force levels for the current year plus eight years into the future. Costs, on the other hand, are reflected for only the current year plus five additional years. The financial data are broken out into three categories: R&D costs, which are self-explanatory; investment costs or the capital investment, which are the costs required to put a newly developed capability into operational use; and operating costs, the recurring costs required to man, operate, and maintain the capability.

The Army Five-Year Force Structure and Financial Program is currently organized into 12 separate volumes. Included are a summary volume, individual volumes for each of the six DOD Programs in which the Army has activities, and five annexes. (See Fig. 6.)

The summary volume shows by major programs the estimated costs in each appropriation, and the manpower data used in formulating the five-year program. The six major programs in which the Army has program elements summarize the use of Army resources in mission purpose terms. Supporting this mission/purpose breakout are detailed annexes, similar to the old "Control Programs," that show what we have programmed in functional areas. The Materiel Annex, for example, provides a five-year shopping list for major items of equipment. The Construction Annex portrays like data on our military construction projects for the same time period. The other annexes are designed to provide similar data in each area indicated by the title of the annex.

The only annex not complete at this time is the Force Basis Annex and this is a real void in our documentation. The Force Basis Annex will provide current guidance to the DA staff and major commands concerning the programmed unit composition of the Active Army, the Reserve components, and proposed AUS augmentation units. This annex should be completed by 1 July of this year.

These functional annexes are the basis for the detailed program and budget guidance which is provided to the major Army commands and agencies below Departmental Headquarters level. Last year,

MAJOR PROGRAMS

PROGRAM ELEMENT SUMMARY DATA SHEETS

PROGRAM ELEMENT DESCRIPTIVE DATA SHEETS

MATERIEL ANNEX

PEMA SHOPPING

EQUIPMENT DATA SHEETS

CONSTRUCTION ANNEX

FORCE BASIS ANNEX

INSTALLATION ANNEX

FAMILY HOUSING ANNEX

Fig. 6. Documentation for Army Base Program.

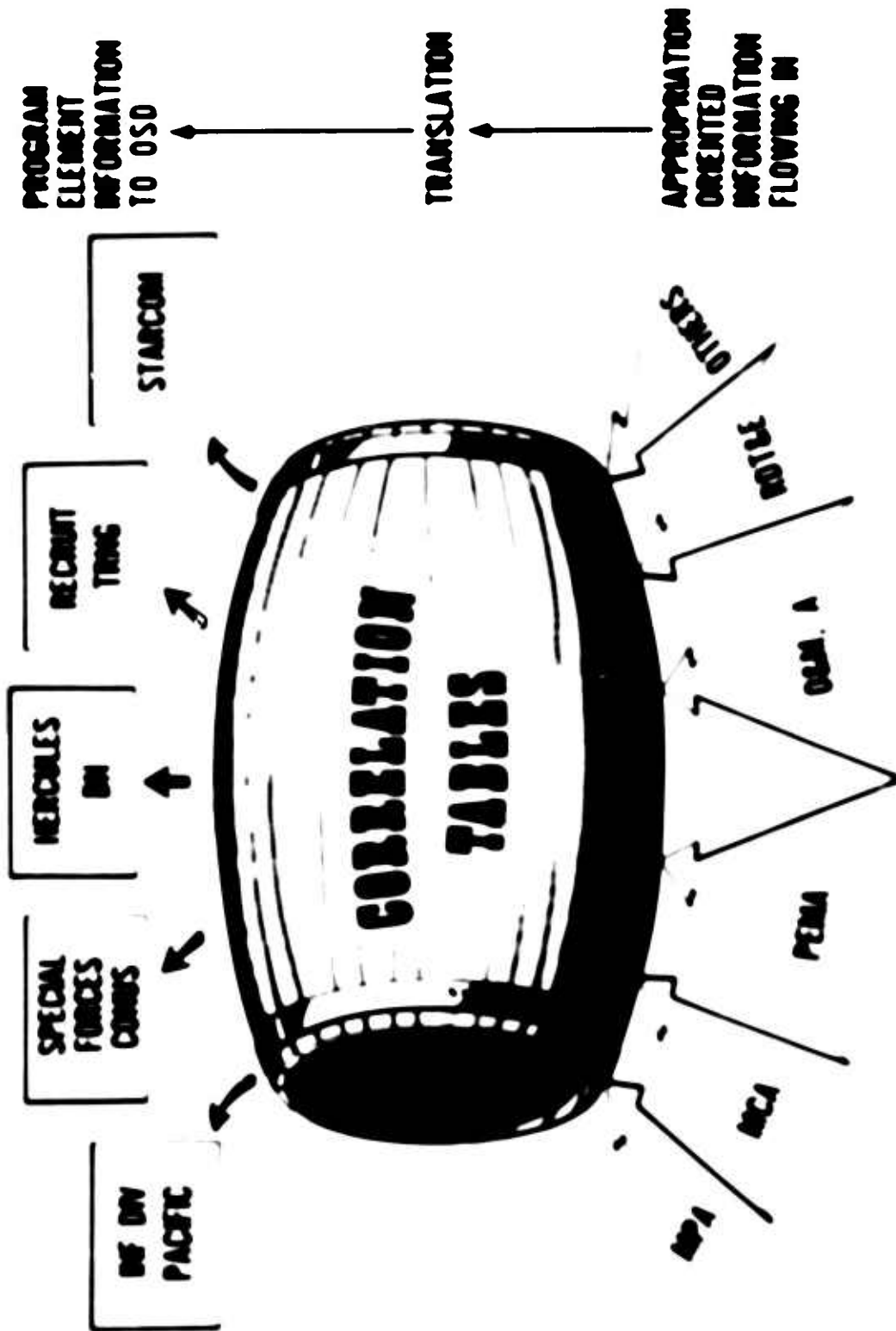

Fig 7 Appropriation/program element correlation

using the basic data available in the annexes, we were for the first time able to provide five-year guidance to the field. In the past, our guidance has been limited to one year and our field commanders have often expressed their need for definitive guidance over a longer time frame.

As has been said a number of times, the programs and program elements are mission purpose-oriented. The budget structure, on the other hand, is functional and the Army below Departmental Headquarters continues to employ a management system based on the functional budget programs such as pay, construction, and procurement of equipment.

Figure 7 portrays the translation problems implicit in this difference, in very simple form. Taking our functional or budget-based inputs, the Army staff, employing a series of correlation tables, represented here by the barrel, allocates resources to the mission purpose elements. We must at all times be able to display our resource needs in both forms, since we normally deal with OSD in mission program terms and our communications to the Army's field establishment are in functional budget terms. In essence, we employ the program structure and channels in decision-making, but executive controls in execution are in budget terms. The correlation of dissimilar structures is still far from perfect, and we are currently realigning part of the functional management structure used below Headquarters, Department of the Army, so that reports from the field will correlate more directly to the program element structure. We are also studying ways of making a more meaningful distribution of overhead or indirect costs to program elements.

Since Army activities are never static, the Base Program can never be static. The logical question, then, is, how do we keep the Base Program current? Heretofore, most plans and programs were revised periodically, normally on an annual basis. This is where the current system deviates greatly from the past. By using a formalized program change control system, changes to the program can be recommended at any time. In theory, then, the Base Program is always current — a living document.

In accord with the management-by-exception principle, the Secretary of Defense has established specific criteria covering change proposals which must be submitted to his office for approval. He has done this by establishing decision thresholds. (See Fig. 8.)

A threshold is an upper limit which cannot be exceeded without the personal approval of either the Secretary of Defense or his deputy. The current thresholds are shown in the figure. For the most part these thresholds are conveniently grouped into three "Cost Type" categories: research and development, investment, and operating. There is also a "Forces and Manpower" threshold which limits changes

	FIRST PROGRAM YEAR	TOTAL PROGRAM
RESEARCH & DEVELOPMENT		
NEW PROGRAM ELEMENTS (VI)	ANY	ANY
CHANGES TO PROGRAM VI	\$10,000	\$25,000
INVESTMENT		
ITEMS UNDER DEVELOPMENT	\$10,000	\$25,000
CHANGES TO PROGRAM ELEMENTS	\$10,000	\$25,000
MATERIAL ITEMS	\$10,000	\$25,000
CONSTRUCTION PROJECTS	\$5,000	\$10,000
OPERATING COSTS		
CHANGES TO PROGRAM ELEMENTS	\$20,000	\$50,000
MILITARY ASSISTANCE PROGRAM		
NEW COUNTRY	ANY	ANY
CHANGES TO COUNTRY TOTAL	\$2,000	\$5,000
FORCES & MANPOWER		
CHANGES IN FORCE LEVELS	ANY	ANY
CHANGES IN YEAR-END STRENGTHS	ANY INCREASE	ANY INCREASE

Fig. 6. OSD program structure.

to end-year strengths and force structure units, and an MAP threshold. As a general rule, the thresholds are somewhat more restrictive in the near years.

The Army, within these limits, can institute "Below Threshold" changes to the Base Program. Of course, program change proposals must be submitted in all cases where the change requires resources in excess of the levels in the last Army Base Program approved by the Secretary of Defense.

Program change proposals which affect the Army Base Program originate from many sources: the Secretary, Deputy Secretary, or Assistant Secretaries of Defense; Chairman, Joint Chiefs of Staff; other military departments or independent DOD agencies. Of course, the bulk of the change proposals are initiated by the Army staff.

Proposed changes are forwarded to OSD for decision on a standardized program change proposal form. The change proposal is the life-blood of the system; Fig. 9 shows what basic information is required.

Page one of the form outlines "What you want and why you want it." The specific areas addressed in each proposal are shown in the figure. Page two presents primarily cost information, and in brief asks, "When you want the money and how much." For example, if the change concerns a materiel item, you would indicate the year you want Congress to appropriate the funds and the year, or years, in which you anticipate delivery. The costs of the proposal are presented in the three categories — R&D, investment, and operating. Page three presents some of the details on "resource requirements versus availability." On this page the question of "trade-offs" is resolved, and your specific requirements are listed. One item of interest on this page — the program change is a Secretary to Secretary communication and each proposal is signed out by the Secretary of the Army. At the OSD level Secretary McNamara or his deputy makes the decision on every proposal.

A program change proposal travels a rather long and winding route on the road to decision.

Let's follow a hypothetical program change, assuming the proposal originates in the Army staff. (See Fig. 10.) The appropriate staff element initiates the change and then coordinates the change with all other Army staff agencies. After coordination, the change is forwarded to the Office of the Director of Army Programs, where it is reviewed for consistency with the overall program, and for the preparation of a "summary analysis." This summary analysis presents the various considerations that were part of the development of the change proposal and recommends a course of action selected from a number of alternatives.

<p>WHAT YOU WANT AND WHY YOU WANT IT</p> <p>IDENTIFICATION OF ELEMENT ULTIMATE OBJECTIVE BASIS FOR CHANGE R&amp;D STATUS FACILITIES</p>	<p>WHEN YOU WANT THE MONEY AND HOW MUCH</p> <p>YEAR OF FUNDING YEAR OF DELIVERY R&amp;D COSTS INVESTMENT COSTS (MCA &amp; PEMA) OPERATING COSTS (OMA &amp; MPA) FORCE/ITEM OBJECTIVES FIRST LINE LIFE</p>
<p>REQUIREMENTS VS AVAILABILITY</p> <p>SAVINGS IMPLICATIONS MANPOWER REQUIREMENT SPECIFIC APPROVAL FINANCING IN CURRENT &amp; BUDGET FY (S/A) SIGNATURE</p>	

Fig. 9. Program change proposal format.

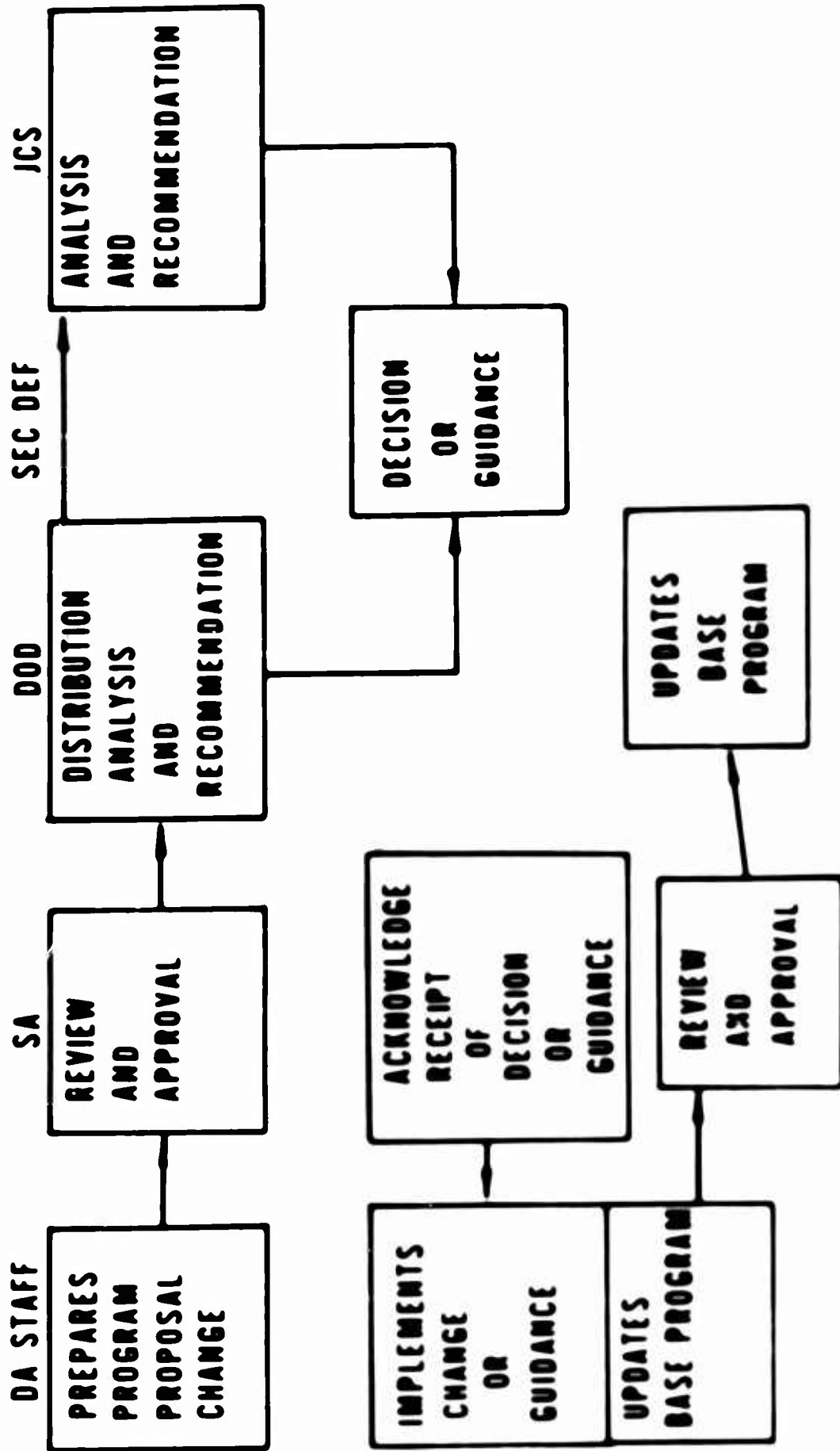

FIG 10 FLOW CHART FOR PROGRAM CHANGES

The Chief or Vice Chief of Staff then forwards the change proposal to the Secretary of the Army. If the Secretary of the Army approves the change proposal, it is forwarded to OSD, where it is processed by the staff of the Assistant Secretary of Defense (Comptroller). At OSD level the proposal is circulated for review and comment to the Joint Chiefs of Staff, DOD Staff Agencies, and the other Services. Based on these comments, the Secretary of Defense makes his decision and issues instructions to the Service concerned.

The Secretary of the Army can either accept and acknowledge the decision of the Secretary of Defense, or he can exercise his reclama privilege if the decision is not acceptable to him. Assuming approval, the next step is to update the Base Program. This is a mechanical process of preparing revised Program Element Summary Data forms and distributing them to all holders of the Base Program. With revised Program Element Summary Data forms inserted into the Base Program document, the circuit is closed and the Base Program is again current.

#### CONTROL DEVICES

Every successful management system must contain a procedure for review, and the DOD Program System is no exception. Although not perfected, DOD is experimenting with two approaches.

One approach is to require Monthly Progress Reports on selected materiel items or systems over which OSD desires to maintain close supervision. The Army items are shown in Fig. 11. A "milestone schedule" is being developed for each of these items. A "milestone" is a significant occurrence in the life or scheduling of an equipment item, extending through the development, production, and operational phases to obsolescence and removal from inventory. Milestones will indicate whether the particular item is developing as originally projected or whether it needs additional management attention to bring it to the desired operational state. The Army must be prepared to explain in detail and justify any deviation of actual accomplishment from programmed milestones.

For each item or system, the Army has designated a DA Systems Staff Officer to serve as the DA focal point. This Systems Staff Officer supplements the materiel Project Manager found at Army Materiel Command and other field commands, and is to be thoroughly knowledgeable on the overall status of the item. ACSFOR monitors progress to insure coordination of the materiel facets with doctrine, training, organization and deployment.

Another control device is called Resource Category Reporting. A resource category is either a unique type of resource or a homogeneous grouping of related resources. They can be viewed in

COMMUNICATIONS SATELLITE	MACHINE GUN, M-60
AIRPLANE, MOHAWK (AO-1)	MAULER
GENERAL SHERIDAN (XM 551)	LANCE
CBU 1A/2A	MORTAR CARRIER (T257E1) (XM106 SP)
CARRIER, PERSONNEL (M-113)	NIKE HERCULES
CARTRIDGE, 7.62mm	NIKE ZEUS
CARTRIDGE, 105mm, HEAT (M-456)	PERSHING
C&R VEHICLE (T-114)	RADIO SET (AN/VRC-12)
DAVY CROCKETT	RECOVERY VEHICLE (T120E1)
ENTAC	REDEYE
HAWK	RIFLE (M-14)
HELICOPTER, CHINOOK	SERGEANT
HELICOPTER, LOH	SHILLELAGH
HELICOPTER, IROQUOIS	TANK, M-60
HOWITZER, SP, 105mm (T195E1)	TANK RECOVERY VEHICLE, M-88
HOWITZER, SP, 155 mm (T196E1)	DAIS
HOWITZER, 8", M-110 (T236E1)	VX FACILITIES - MUNITIONS

Fig. 11. Reporting requirements.

management terms as a "functional slice" of the program.

At this time, we identify only four types of resource categories, namely (1) major R&D projects, (2) major PEMA items, (3) major construction projects, and (4) manpower costs. Other types of resource categories will be identified in the future.

Resource category reports are used for comparing the actual execution of programs in various categories against the original schedules. Problems encountered, or improper execution of schedules, in these high-cost areas will be identified quickly for prompt remedial action.

In sum, in the reports area, as in other areas, we are in the process of refining an operational program system to make it an even more effective tool of management.

#### ARMY BUDGET PROCESS

I will not dwell on the Army budget process, not because budgeting is not important, but because it has changed little in recent years and is generally well understood. In the final analysis, the budget process is the means of securing resources and allocating them to those areas which will provide the greatest return in combat effectiveness. It is through the budget process that the projected plans for operation of the Army, as well as its long-term readiness, are presented for review and acceptance by higher Executive authority, by the Congress, and, finally, by the American people.

The budget document reveals the near-year costs of carrying out the program. In this context, it should be only an annual slice, an increment, of the five-year program. Of course, at budget time the real world intrudes on this ideal relationship and the annual budget review is still a painful process. And, while the Army budget is considerably larger than it was just a few years ago, we are all aware that there is still not nearly enough money to sustain all of our programs, and to do all of the things that we know should be done. However, as we refine our planning and programming systems, the objective of having "programs become budgets" is closer to realization.

The budget has long been held to be the critical element in the execution phase of the management system. It is significant to note that the program system offers nothing to replace it. I mention this because a few people have suggested this possibility. The existing budget controls are rooted in law, are operational and effective, are served by an adequate accounting mechanism, and have the unique quality of being understood by the Army establishment worldwide. The Army cannot replace this system without the consent of OSD and Congress, and neither has indicated any desire to change the status

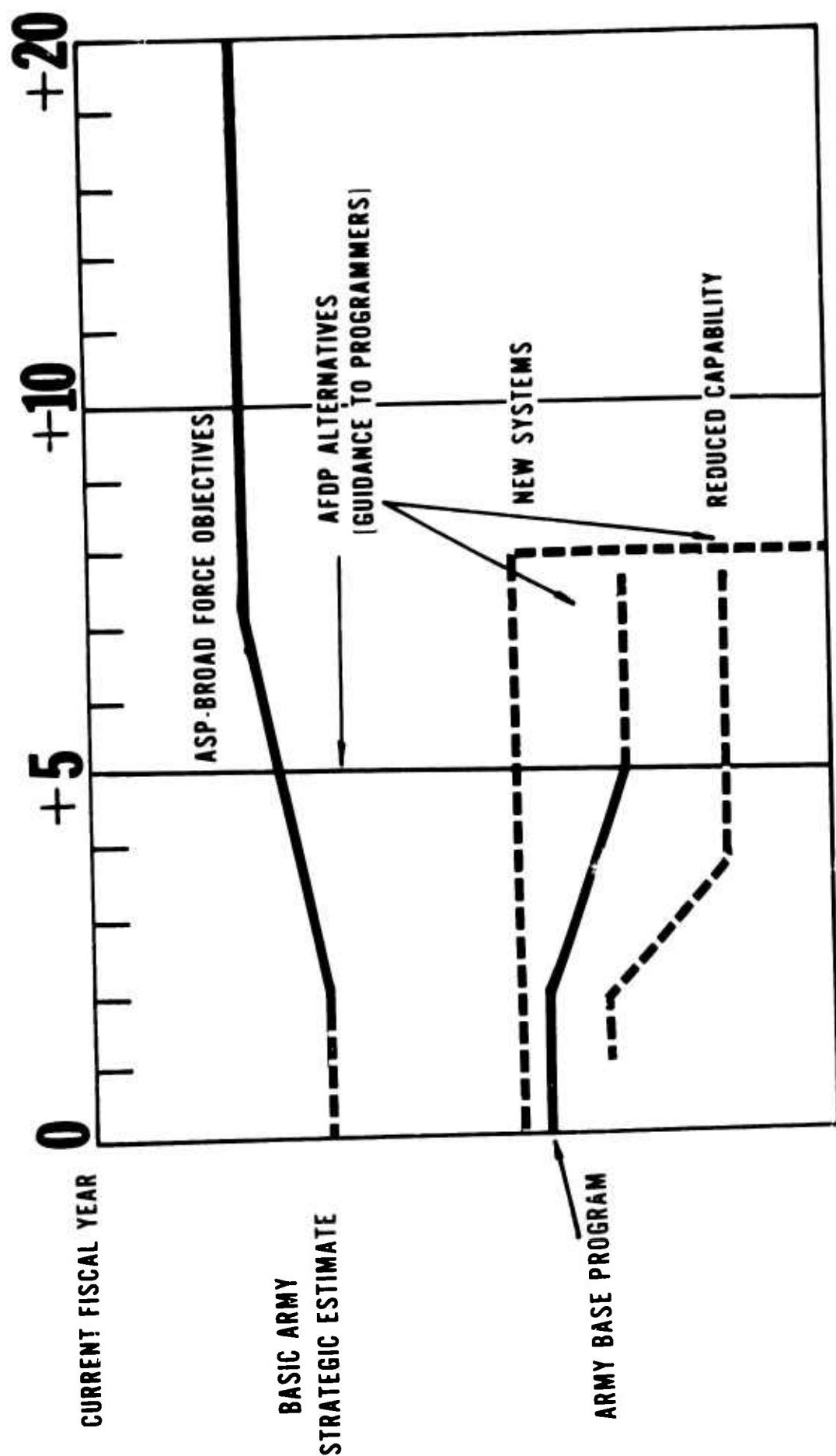

FIG. 12. PLAN / PROGRAM RELATIONSHIP.

qu ). Thus there is little evidence to justify the extension of a dual program-oriented control system below DA Headquarters.

#### PLANS AND PROGRAMS

I would now like to retrace my course somewhat, and show how our plans and programs tie together, or, more specifically, how planning objectives flow into the program and ultimately into the budget. Figure 12 provides a graphic portrayal of the plan program relationship.

I would caution you not to associate any specific resource scale with this figure. For our purposes, just assume that planning requirements exceed our present capabilities. The heavy black lines on the lower half of the figure represents the Base Program — or level of resources — as currently approved by the Secretary of Defense.

On the left, we have portrayed input from the BASE as providing for the 20-year time frame an environmental forecast and guidance on strategy adequate for the development of other more definitive plans. From this guidance the Army staff develops the Army Strategic Plan which establishes the Army's entry position on force and resource levels for JSOP deliberations, and sets those objectives toward which the Army directs its efforts. The Force Development Plan, oriented toward those objectives, provides the detailed guidance for effecting necessary changes to the Base Program to achieve the stated objectives within reasonably attainable resource levels.

The guidance we expect from the AFDP falls into the three general areas mentioned earlier.

*First*, we expect the plan to examine what is currently in the approved base to identify areas for improvement, and, at the same time, identify the high priority items and systems that we would bring in first if we assume a projection of resources at about the FY 64 level. As you note, the base program has a downward bias as we proceed into the future time frame. Basically, this is caused by the DOD prohibition against including forces and cost — other than R&D — in the mission programs when an equipment item is still in the developmental stage and has not been approved for deployment. This is true even though it is contemplated that such materiel will be ready for procurement during the program period. For example, we could anticipate a production decision on Nike X or on some such high cost system prior to end FY 1968. The force levels and related investment and operating costs are identified in the Force Development Plan — based on the predicted readiness dates. The AFDP tells us when we should submit a program change and about how much to ask for. This is a typical example of how the Force Development Plan provides the guidance for initiating a program

change to secure authority to include the new materiel and related forces in the Army Five-Year Force Structure and Financial Program.

Next, it should outline alternative ways of attaining the objectives level of the Army Strategic Plan. In so doing, it should detail the incremental steps involved for a number of alternatives. For example, one alternative might get us to the objectives level in two annual increments. Another alternative, on the other hand, might portray a much more conservative approach in attaining the desired objectives.

Third, the AFDP should provide a decrement list to accommodate a decision to reduce resource levels below current projections. In other words, it tells us what will hurt the least if we must absorb cuts in the future.

We can see that the force development plan, in PERT lingo, presents the optimistic, the most likely, and the pessimistic view of future expectations.

The new emphasis on a DOD-integrated management system has already had a profound effect upon the management activities of the Military Services. The program system has undoubtedly been the most significant change. The establishment and maintenance of an approved program over an acceptable time span organized in mission-purpose terms, encompassing the total activity of the DOD, places before top-level decision makers more organized information than has ever been available in the past.

While the program system, as well as other facets of management, is still far from perfect, the possibilities inherent in the new system would seem to fully justify the effort which will be required. Our ultimate goal is the achievement of a practical process for transforming well conceived military plans into effective actions which in total provide the degree of national security required for the future development and growth of our nation.

Although the Army has made significant steps in aligning its own management system with the evolving OSD model, much remains to be done. It is recognized that a more effective means of correlating planning, programing, budgeting, and program-budget execution must be developed. In this regard, the Army has recently initiated a study designed to achieve improvements in the Program and Budget Systems. A steering committee, consisting of myself, the Comptroller of the Army (as chairman), the Assistant Chief of Staff for Force Development, and the Deputy Chief of Staff for Logistics, has been established to provide overall direction and guidance to Army staff agencies in the development of improvements during the conduct of the study.

The system developed must serve with equal advantage the Pentagon decision maker and field commander charged with carrying out the decisions. The Army staff has a unique opportunity to shape this system to serve their needs and fully intends to do so.

## CONCEPTS OF THE COMMAND CHANNEL STOCK FUND

Mr.  
**JAMES C. JENKINS**  
 Chief, Office of Working Capital Funds  
 Office of Assistant Secretary of the Army (FM)

Too often instructions come to you in the field to install this or that system with operating accounting and reporting procedures for its operation. Too seldom are the significance of the system, the philosophy behind its adoption, and the principles of management inherent in it to obtain maximum operating results clearly presented and understood. It is my purpose today to try to provide some of this background so that the importance of your part in the Command Channel Stock Fund operation may be clearer to you during your deliberations here and in its operation when you return home.

The mission of this School is "To assist commanders and selected staff officers and civilians to perform managerial functions pertaining to installations and activities." We find further that "command management includes programing, budgeting, accounting, manpower, and logistics management" and that "command management encompasses the functions of management, which are planning, organizing, directing, coordinating, and controlling."

Since the Command Channel Stock Fund is not just a financial gimmick but is an instrument of logistical and financial management, it is an integral part of the programing, budgeting, accounting, and logistics management with which you are concerned and for which you are picking up ideas at this School to improve the management of these things.

Because you are some of the key people in the management of the Army, Navy, and Air Force, I think you have a need to know, a need to know how this or any system we discuss can contribute to management. We want you to know what the Command Stock Fund is and what it is supposed to do. Because you are the key people, many of you will be located at the Department of Army from time to time; you may be in AMC or at inventory control points, you may be commanders of stations, you may be in an overseas command. In any of these capacities you may be staff officers, program managers, commanding officers, or supply and financial managers. But in any

*For many years Mr. Jenkins has been engaged in activities relating to the installation of the Army Stock Fund as a means of financing the procurement and managing inventories of secondary material. His experience has been gained in private industry, life insurance, salesmen, education, university instructor, and Government, among others, budget analyst.*

*The present paper was prepared from the transcription of an oral presentation made at USAMS, Fort Belvoir, Virginia, on 23 October 1961.*

of these capacities at any of these places you will have a part in the command of the installation. If we have a Command Channel Stock Fund at these places there is not going to be much question but that you will have a part to play in it because you cannot avoid it. And I do not think you do want to avoid it.

As background for the discussion of the Command Stock Fund, I think it would be extremely interesting to give in brief a summary of policy decisions with respect to consumer funding and stock funding that were included in the Gilpatric Memorandum of 30 March 1963 in reply to the General Accounting Office. Consumer funding, stock funds, and command stock funds are to say the least controversial both within the Army and outside. However, there is nothing that dampens controversy like a policy decision. Until 30 March 1963 we did not have any real clear-cut DOD policy decisions with respect to stock funds and consumer funding. Each of the Services had implemented in varying manner stock funds both as to coverage of items and depth of extension. For example, the Navy which had the oldest stock fund, used in many years for purely consumptive type material (subsistence, general housekeeping supplies and clothing), some electronics material, etc. Up until 1951 or 1952 the Army had no stock funds at all, and then in a three-year period they practically put everything in it. As for the Air Force, it just has not believed in stock funds and therefore has limited it generally to subsistence, clothing, fuel, medical and general supplies. The Navy has now approached more closely what the Army has been doing by putting in a lot more of the technical type of material.

Because of the shortage of consumer funds, not applying them in the right proportions to buying materials from the stock funds, and various other reasons, the GAO about two years ago started a very serious study of stock funds and consumer funds. This study recommended that stock funds and consumer funds be pulled back to the CONUS depot level or, as an alternative, that both stock funds and consumer funds be abolished. About the same time the Department of Defense supply people had a project which was called the DUMP project, the integration of supply and financial management. This was recommending not the abolition of stock funds in toto but pulling stock funds back to the depot level with no extension below. Then soon after the Defense Supply Agency came into being and it was advocating stock funds at major consuming points, provided that it was a DSA stock fund.

As a result of all these varying points of view and methods of using stock funds and consumer funding, the Secretary of Defense in August 1962 instituted a study to resolve the problem. This study culminated in the Gilpatric Memo of 30 March 1963. There are many things in this study bearing on the subject of my discussion.

First, the Gilpatrick Memo defined items that were to be financed by the stock fund. This includes all items except major end items, assemblies, components, and parts that require a high degree of centralized management, repair parts that are coded exclusively for depot repair, insurance-type items, items directly related to the safety of personnel, items in the research and development stage, and items locally procured where there is no stock fund.

The second thing in the Gilpatrick Memo that was decided was when and where we would use stock funds. Mr. Gilpatrick informed the Comptroller General of the United States that it would be mandatory for all three Services to use stock funds at CONUS depots and at overseas depots. Extension below the depot level for each of the Services and the type of stocks used were permissive provided that the type of extension was uniform within the Service. In other words, we could not use a command-type stock fund in CONUS and a vertical-type stock fund overseas. It had to be one or the other. Also, stock funds had to be used for clothing and subsistence items that were expended primarily to military personnel appropriations down to the lowest feasible point. And this has an interesting application, because we are now putting stock funds in the forward points in Europe for clothing and subsistence under remote accountability.

Here is another interesting point that has a bearing on some of the things that I am sure you are interested in. Department of Defense policy now requires that consumer funding be at the installation level, as set forth in the following statement: "With few exceptions, experience has proven that the best budget center for the consumer funds is the base level. This is the location where the ability to forecast requirements exists and where the best judgment can be applied with respect to the relative priority of the (DDI) programs as established from higher echelons. As management people, I am sure you are interested in some of the aspects of that statement."

Another interesting thing that was decided in this particular memorandum was that "separate financial restrictions will not be imposed on base commanders with respect to the use of available operating funds as contrasted with other base operating costs." This means that there would be no separate financial restrictions on money for materiel as distinct from other operating costs. In other words, we at the Army level or CONARC headquarters or any of the armies cannot establish separate restrictions on the money in O&MA for materiel consumption. This can only be done at the station level and not above. And, finally, "a system of financial inventory accounting of materiel below the depot level is required in all military services." Keeping in mind this latter point, if you have financial inventory accounting, the installation of the stock fund

becomes somewhat easier, entailing almost no extra work and providing an inventory management system that we think is effective.

No doubt you have heard statements to the effect that the size of inventories at CONUS installations hardly justifies all of the management, accounting, and reporting inherent in a stock fund operation. The smaller the station we are considering may seem to lend credence to this assertion.

However, the aggregate of the inventories at all Class I CONUS stations will approximate \$150 million on hand and \$85 million on order. Sales will approach the \$770 million level annually. This can hardly be dubbed a peanut operation. The maintenance of inventories on hand and on order in a reasonable state of balance to meet an annual sales program of this magnitude covering as high as 20,000 to 25,000 items at larger stations justifies the application of competent supply and financial management. Since the level of competent management for the whole division is the aggregate of the level of competency of all the armies and stations having the stocks, it is essential that personnel make the most effective contribution of which they are capable to the installation's logistics activities. However, the impression should not be left that the dollar value of sales and inventories is the major significant aspect of this program. Of far greater significance is the supply management of the program within available resources so that the right items, in approximately the right quantities, are in the right place at the right time. Among other things, the extent to which this supply objective is attained will have an impact on such things as:

1. Adequate feeding of troops.
2. Availability of personnel and organizational clothing.
3. Availability of materiel for training of troops.
4. Readiness of equipment for training, deployment, and combat.

As background for some of the philosophy and rationale underlying the use of the Command Channel-type Stock Fund, it appears important to briefly review what a stock fund is and why the Army has chosen to use it at any level.

There are essentially two methods of financing the buying of materiel from a manufacturer or supplier for stockage, distribution, and use. One of those is a direct appropriation made annually by Congress for this purpose. This is the method used to buy major end-items such as tanks, personnel carriers, trucks, etc., and major components and assemblies such as engines and transmissions. These items are issued to the user free of charge without the necessity of any financial consideration on the part of the user to obtain it. These are generally higher unit cost items ranging into thousands of dollars

each. Their importance and extreme variability of demand require that the management of each line item of materiel be subjected at all levels to a high degree of centralized knowledge of the supply and readiness status of these items wherever located and, in some cases, including those in the hands of the troops. About 400 of these items represent the major portion of the Procurement of Equipment and Missiles Appropriation. This number is small enough to permit a review on an item basis both within the Army, by higher authority, and even by Congressional Committee. This high degree of item control at all levels decreases the need to exercise a high degree of broad financial control.

The only purpose in discussing this group of items is to illustrate the differences in the application of financial and materiel management techniques to this group of items contrasted with those used for the next group of items to be discussed. Contrasted with the relative handful of items financed under PEMA, there is another group of items generally categorized as consumable-type items such as subsistence, clothing, and housekeeping supplies. Also included are spare parts, smaller assemblies, and minor end-items of equipment. These items are the fast turn-over type of items and, when put into use, represent a cost of doing business. In the total Army system, there are about 500,000 of these items. At an average size installation, about 20,000 of these would most likely be stocked. In an overseas area the number stocked might well exceed 100,000 items. The fast turn-over consumptive characteristics of these items and the large number of items involved not only permits, but requires, a different type of supply and financial management. First, central knowledge and control of world-wide assets on an item basis is not required. As a substitute, therefore, control can and is exercised over these items by establishing separate policies for stockage objectives to be maintained at the various levels, viz., CONUS depots, CONUS stations, and in overseas areas. The appropriate stockage levels are then computed by the application of these policies to anticipated issues at the various distribution levels. This of course must be done on an item basis at the operating levels. For example, CONUS inventory control points must review items to determine initial procurement requirements from the manufacturer, and stations and overseas areas must review items to determine quantities to be requisitioned from depots or procured locally.

However, for purposes of determining the fund requirements at each level and exercising broad control over the execution of the materiel program, the supply determinations made with respect to each item at the operating level are priced out so that requirements and assets can be reviewed above the item analyst on a dollar basis. In

fact, considering the large number of items involved, even at a station, this is the only feasible technique for review and management. This is, in effect, what the Army generally refers to as financial inventory accounting. It tells you how much you have, how much you have issued, why you have it and where it is. However, in and of itself, financial inventory accounting provides no method of financing the required inventory levels and no technique for exercising supply and financial control over the management of these inventories consisting of such a large number of items.

For this purpose, the Army has chosen to use the stock fund as the most feasible financial vehicle for assuring adequate and continuous financing of authorized levels of supply. At the same time, it provides a technique for exercising management control at all levels of supply with a high degree of decentralized management to the lowest level.

A stock fund is a working capital-type revolving fund. Under this system, assets, consisting of inventory and cash for working capital, are capitalized into a business-type operation. Its assets are subjected to the requirements of a double entry business-type accounting. The law requires that the fund be charged for the cost of inventories which it must acquire to meet demand. Likewise, it must be reimbursed for issues (sales) of materiel made to consumers. The consumer pays for this materiel from appropriations made by Congress to the various operating appropriations such as Operations and Maintenance and Military Personnel Appropriations. These reimbursements for issues (sales) provide the stock fund the financial resources with which to make new procurements of inventories to replace those sold to consumers. Therefore the financial resources required for replacement can be made to parallel the determination that replacement must be made on an item basis.

#### PRINCIPLES OF A STOCK FUND

In summary, the principles of a stock fund are as follows:

a. Stock funds are revolving funds established to finance the orderly and timely procurement to maintain a level of inventories on hand and on order necessary to support operational requirements. These levels include:

(1) Normal peacetime levels established in accordance with Army policies authorizing such levels. These must be related to realistic anticipated issues (sales) for which operating funds may be expected to be available and used to reimburse the stock fund.

(2) Provisioning of a reasonable level of support for new items of equipment on a realistic basis until deployment of the item.

and experience with its operation has reached a status that permits the determination of realistic usage rates.

(3) War reserve levels in accordance with DOD policies establishing acquisition objectives for such reserves.

b. Stock funds are required to pay, when appropriate, for the cost of materiel procured.

c. Stock funds must be reimbursed from available appropriations for sales of materiel withdrawn from the stock fund for use.

d. Stock funds require that the capital of the fund (cash and materiel) be accounted for in a manner that explains:

(1) What has happened to cause the capital (cash and materiel) at the end of the period to differ from the capital (cash and materiel) at the beginning of the period.

(2) The reasons for a change in the distribution between elements of the capital during the period, i.e., the difference between cash and materiel at the end of the period compared to that at the beginning of the period.

Now let's turn to the Command Channel Stock Fund — what it is, why selected, and some of the management requirements.

#### WHAT IS THE COMMAND-TYPE STOCK FUND?

a. The Command-type Stock Fund is a revolving fund exactly like the overall Army Stock Fund.

b. It is a part of the overall Army Stock Fund, in effect, a revolving fund within a revolving fund.

c. It is a separate, but complete, revolving fund and is organized within the total Army Stock fund for each command. For example, there will be one for USAREUR, one for USARPAC, etc. Further, in the case of CONARC, this principle of organization is carried to the Army and station level.

d. Each command is assigned primary responsibility for the operation of its Command Stock Fund subject to Department of the Army direction and control.

e. Responsibilities, direction, and control are exercised through the same command channels as those used for all other assigned missions.

f. Each command will have only one Stock Fund Division to include all 18 categories of stock fund-type materiel.

g. Its purpose is the same as that for any other stock fund to finance the orderly and timely acquisition of materiel to maintain the required levels of inventory on hand and on order to support the command's assigned operational requirements.

h. Its principles of operation are the same as those for the total Army Stock Fund.

- (1) Its assets consist of materiel in the command plus cash allocated to the command division.
- (2) It must pay for materiel acquired from:
  - Army Materiel Command Stock Fund.
  - Defense Supply Agency Stock Fund.
  - Local and any other procurement.
- (3) It must be reimbursed for materiel issued (sales to customers).
- (4) It must be operated by the command, army, and station to acquire the kind of materiel and in the quantities that can be sold (except War Reserves).
- (5) It must account for its assets.

#### WHY THE COMMAND CHANNEL STOCK FUND WAS SELECTED

Within the parameters of the Gilpatric Memo, let's examine the reasons why the Army chose the Command Channel Stock Fund. First, under the terms of the Gilpatric Memo it was mandatory that we choose a stock fund for overseas and it had to be either vertical- or command-type. The Army had enough experience with the vertical extension to decide that it did not want to continue its use. Under the vertical stock fund, you can move centrally procured materiel from CONUS into Europe or any other place where there is a vertical stock fund without any financial consideration. The stock fund is under the CONUS-AMC inventory control points. Europe, on the other hand, is running the supply business over there. And since they had no financial control over the movement of stocks under this stock fund concept material is often ordered far in excess of their requirements. Someone may say, "So what?" Well, within the confines of trying to keep initial procurement from manufacturers down to what is needed to provide support for the total Army, and thus avoid any unnecessary expenditures of Uncle Sam's money, keeping in mind that you have only so much material, the minute you move too much in excess of demands in one location, you are going to wind up with shortages for somebody else.

Because of such difficulties with the vertical stock fund, and in view of the fact that we have to extend one to overseas, the Army plans to use the Command Stock Fund overseas as well as using it at CONUS stations, which constitutes half of our business.

The Command-type Stock Fund has been selected as the best type of stock fund extension because:

- a. It places responsibility for total local management of the command division on CONARC, Army, and the station, and is therefore consistent with the Army's concept of command management responsibility.

b. It simplifies supply and financial management under the stock fund by:

(1) Including in one stock fund division 18 existing materiel categories currently under the stock fund ownership of 18 separate stock fund entities and managed through 18 CONUS inventory control points under the direction of the Army Materiel Command and the Army Surgeon General.

(2) Funding the Command Stock Fund with resources with which to acquire its appropriate materiel requirements. This is in lieu of the present system of funding separately each category of materiel insofar as local procurement and procurement from the Defense Supply Agency are involved. It is also in lieu of using Operations and Maintenance appropriations to finance inventories where often the level of maintenance of inventories on hand depended on the degree to which O&MA funds could be made available considering other high priority requirements.

(3) It results in improved programing of use of consumer funds. This is due to the fact that a complete Command Stock Fund operating budget program must be prepared by the station, the armies, and CONARC. Since one of the principles of the stock fund operation is to acquire the kind of and the quantities of materiel which can realistically be expected to be sold, the extent of the use of appropriated funds to procure from the stock fund for use must be first realistically determined.

(4) It assists in decentralizing supply and financial management to the maximum extent by using financial management techniques to:

(a) Finance application of Army supply policies.

(b) Review the extent to which performance indicates the application of these policies.

(c) Exercise at all echelons, as appropriate, the responsibility for the application of these policies.

These financial management techniques are just as necessary and useful to the command as they are to higher echelons.

With this background in mind, I would now like to make a few personal observations based on experiences with the Third Army test operations. I hope some of these points will be recalled and discussed in connection with one of your subcourses entitled "Applied Management Techniques." I should like to emphasize that, although this subcourse appears under the heading of "Financial Management" it is equally applicable to "Supply Management." In fact, this leads me to my first observation.

a. The Command Channel Stock Fund is not a financial operation alone. It is a means of financing a station supply operation, namely, the maintenance of inventory levels on hand and on order.

Therefore a stock fund operation in a financial sense is no better or no worse than the supply operation which it finances.

b. Stock fund financial data must, in fact, reflect as accurately as possible supply requirements and stock status. For example, requisitioning objectives computed on an item basis and priced out should reflect in terms of dollars valid supply requirements. However, there are many instances where this has not been the case. An illustration of this occurred recently in connection with a Command Channel Stock Fund review in the Far East. On the basis of the dollar issues of stockage list items, an R/O computed in dollar terms in accordance with Army policy was 25% higher than that reflected in the 30 June financial inventory accounting. Had the financial inventory accounting R/O been accepted, this category's stockage objective would have been under-funded. If the dollar R/O on the financial inventory accounting report actually reflected the computation of R/Os on an item basis and quantities were requisitioned on this basis, there could be actual supply failures occurring. Such was the situation in the case of ordnance materiel at one of the larger Third Army stations early in the test.

c. Care and caution must be exercised in the granting of credits for materiel returned to the stock fund. This caution will need to be exercised to avoid accepting unserviceable items of material that cannot be repaired or to prevent acceptance of large quantities of items which cannot be used or returned to technical service depots and therefore must be disposed of as excess with a resultant loss to your stock fund. On the other hand, the granting of credit for material which can be used in the Third Army or returned to the depots for use elsewhere is not only a fair basis of doing business with the operation appropriations, but also will encourage the turn-in of material which can be used in lieu of new expenditures for the procurement of new items of material.

d. A substantial amount of the accounting and reporting of data under the stock fund can be utilized as applied supply management techniques. For example, the relationship of "physical inventory adjustments," a stock fund account, can be used to measure the extent to which there is a difference between the inventory on the stock records and that which is actually in the bins based on a physical inventory. If the difference continues to be significant, there is a need to examine all aspects of stock control. Therefore it is urged that each of these accounts be considered as having a supply usefulness, as well as a financial usefulness.

e. There is a need to maintain a close correlation between the issue of items and the ordering for replacement all through the years. In stock fund parlance this means a close correlation between sales and the use of acquisition authority to order for replacement. At

times there has appeared to be a tendency in Third Army to use acquisition authority at a rate somewhat higher than sales during the first 10 months of the fiscal year and then make the adjustment in the last two months. If, as a result of this, the items for which higher stockage then may be required are procured during the first 10 months and are the same items and quantities for which there is a requirement in the last two months, this causes no particular problem. However, if this is not the case, the adjustment can be painful.

f. With respect to organization for management, the most effective operations have occurred where primary responsibility for the Command Channel Stock Fund has been placed in the logistics organization and focalized in a responsible individual. This is essential to obtain integrated supply management to include at least:

- (1) Uniform supply procedures and policies.
- (2) Uniform application of supply procedures and policies.
- (3) One channel of supply policies, procedures, guidance, and assistance.

However, the establishment of this focal point of responsibility should not be interpreted as usurping the functions of the Comptroller. Logistics should not only utilize the accounting and budgeting services of the Comptroller but should welcome the independent review and analysis of budgets and supply performance reflected in stock fund and financial inventory accounting reports.

g. The close teamwork between logistics and financial management people is further emphasized by the similarity of meaning between stock fund financial terms and supply terms. In fact, when people present problems that are alleged to be financial problems, ask first, what is the supply problem behind and what would you do supply-wise? The answer to the supply question will more often than not provide the financial answer too. Let's examine a few terms that you will be using.

<b>Supply Terms</b>	<b>Financial Terms</b>
Issues, demands	Sales
Procurement	Acquisition authority
Stockage objective	Stockage objective
Assets	Assets

In closing, I would like to mention a couple of examples evidencing the results that can be accomplished by utilizing the management advantages afforded by the Command Channel Stock Fund. At one of the larger Third Army stations prior to the test and under the vertical stock fund, inventory turnover rate was approximately 4 times a year. During the first year of operation and for every

year thereafter, the turnover ratio was approximated 6 times a year. This represents a definite savings in inventory investment. At the time of capitalization in the Third Army approximately \$4 million of inventory was excess. By the end of the first year, this had been reduced to \$2 million which represented the value of about 2 months of returns from customers. Except during periods of excessive turn-ins from situations such as the Berlin build-up, the value of excess has remained at the level of about 2 months of returns from customers. This indicates a more rapid return of excesses to depot for use elsewhere or more rapid disposal if it is a true excess.

Lastly, I believe I could do no better than to quote the words of General Shoup of the Marine Corps. "The management of a supply system has often been stated in the following lucid and logical manner: 'To have the right item in the right place at the right time and in the right manner.' It is important to realize the system has been designed of necessity to satisfy a number of opposing requirements to fill the maximum number of requisitions with the minimum amount of stock, to provide the fastest possible service with the minimum personnel, to position stocks as close as possible to the consumer without dissipating limited assets; in short, to achieve maximum efficiency with the minimum investment of men, money, and materiel." That is exactly what we hope that management of the Command Channel Stock Fund will accomplish.

The exercise of these elements of good supply management is equally applicable to local procurement and acquisition of materiel from the technical services. If this is done, not only will the Command Channel Stock Fund operate successfully, but you will go far to avoid the problem of major excesses and disposition of materiel at substantial loss to the Government as well as a loss to the stock fund. On the positive side, this kind of operation will provide a sound basis for obtaining the financial resources with which to support your supply program and make it responsive to supply requirements.

SECTION TWO

MANAGEMENT OF ARMY FIELD COMMANDS

## ARMY MATERIEL COMMAND

General  
FRANK S. BESSON, JR.  
Commanding General  
U. S. Army Materiel Command

In talking to you today I will probably spend a great deal of time on organization, because this has been my major concern in the past two years — almost two years.

It was two years ago this coming March that the Army announced its plan to go into a major reorganization. At that time I was put in command of the planning group for the Army Materiel Command, and in August, a year and a half ago, we became operational.

In looking back, the Army materiel functions had been largely handled by seven technical services: Engineers, Quartermaster, Ordnance, Signal, Transportation, Chemical, and Medical. The materiel functions of all of these technical services, except Medical, were put under me for consolidation. Now, when I say the "materiel functions," I have to leave out other functions, because the chiefs of the technical services had certain responsibilities for personnel in their own services. They had responsibilities for training. They had responsibilities for organization and doctrine.

### THE ARMY'S NEW ORGANIZATION

All of these things were changed when the Army established its new organization. I like to oversimplify this because it makes it easier to understand. Basically, the Army's mission in peacetime is well known. First, you have to establish your doctrine; that is, how you are going to fight, how you are organized to fight, and what kind of equipment you will need to fight. "Materiel" is getting those things with which you will fight. Personnel does the fighting. And then you have the job of training, which is the integration of the doctrine, the materiel, and the personnel.

These functional divisions of the Army's mission were the basis for the reorganization of the Army a year and a half ago.

Figure 1 shows the major Army components which have to do with the fielding of unified forces. This is how we accomplish our mission of preparing troops for assignment to the unified forces, and

---

*General Besson was graduated from the U. S. Military Academy in 1932 as a second lieutenant, Corps of Engineers. He later received an M.A. from the Massachusetts Institute of Technology.*

*During the period 1940-43 he supervised the development of wartime engineer equipment. He was in charge of the development of, portable steel airfield runways, portable pipelines, airborne and mountain equipment, and armored bulldozers.*

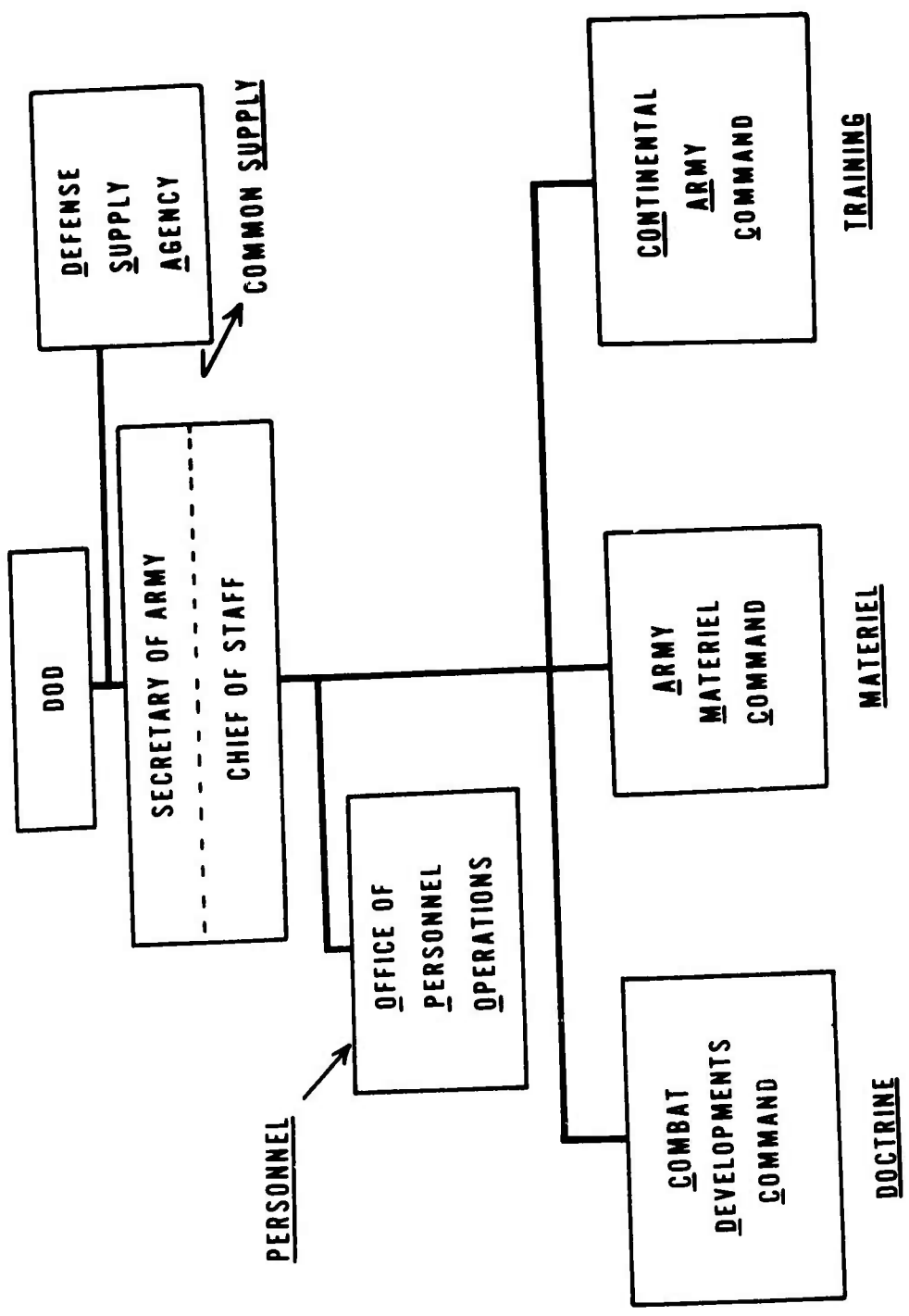

Fig. 1.

preparing them for engaging in whatever operations, cold or hot war, that may be required.

The Combat Developments Command at Ft. Belvoir is responsible for doctrine: It decides how we are going to fight, how we should organize, what TO&E's we ought to have, and what kind of materiel we should have.

It is my job to get the materiel.

And the Continental Army Command takes the materiel, the doctrine, and the people it gets from the Office of Personnel Operations, and translates all of these components into trained fighting units.

The Defense Supply Agency appears at the top in the figure to show in clear context my relationship with the Defense Supply Agency, because I have been asked, at rather high sources sometimes, if I work for General McNamara. (I wouldn't mind, but I don't.)

The Defense Supply Agency is responsible for common items of supply for all three Services. The list of common items is growing. This is fundamentally the difference between the Defense Supply Agency and the supply agencies of the Services: The Defense Supply Agency handles the common items: food, clothing, construction material, medical supplies — getting down now into aircraft common parts and automotive common parts. For those things peculiar to the Army, I am responsible for the whole gamut of the logistical chain from inception to disposal.

#### SOME FACTS ABOUT AMC

As shown by Fig. 2, we have a Deputy Chief of Staff for Operations, who is responsible for the Army Strategic Plan, which tells us how the Army is going to fight.

Then there is a Chief of Staff for Force Development, who is responsible for the scheduling and the planning of the development of forces. He really is the coordinator of the CDC, AMC, and CONARC in the general business of translating ideas into trained troops.

We have an Assistant Chief for Research and Development who basically looks to me for the development program.

Personnel furnishes the manpower input.

---

*In December 1943, General Besson was assigned as Assistant Director and General Manager of the Third Military Railway Service in Iran. In the spring of the following year he assumed full command. While in this assignment he was promoted to brigadier general.*

*During the final offensive build-up for the war against Japan, he held a key position as Deputy Chief Transportation Officer (Operations), Army Forces, Western Pacific. In early August 1945 he was ordered to assume complete control of the railroads in the Eighth Army's assigned Zone of Occupation in Japan. His actions led the Eighth Army commander to comment that "his supervision of the operation of the entire Japanese rail system during the first year of our occupation was the greatest single factor in the results attained."*

*Returning to the U. S. in 1948, he served as an Assistant Chief of Transportation*

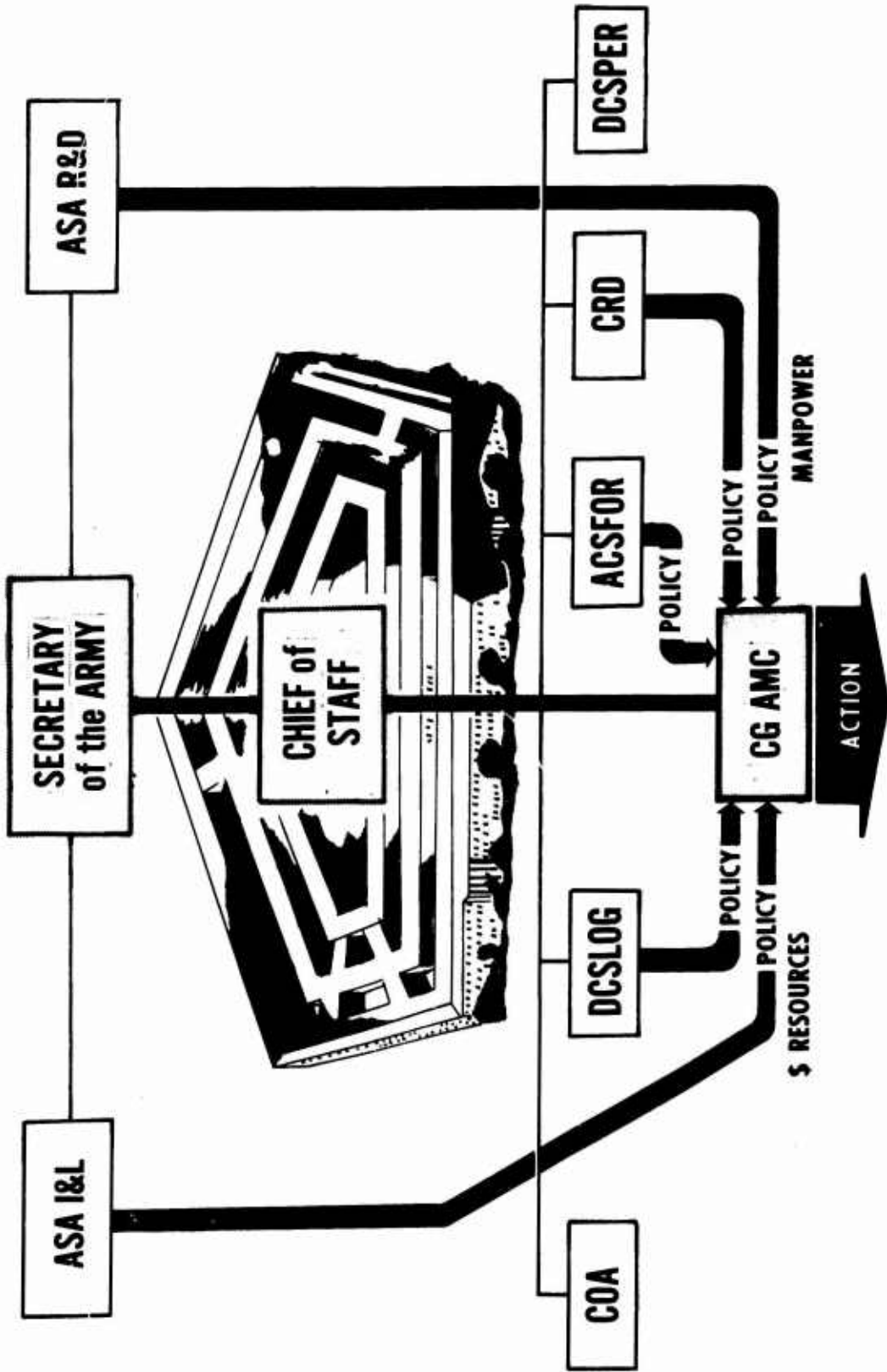

Fig. 2. AMC command and staff relationships.

Logistics handles the distribution problem. The procurement aspects of logistics really bypass the Army military staff and go to the Assistant Secretary. One area in which I deal directly with the Assistant Secretary is on not what we buy, which is DCSLOG's job, but how we buy it. I go to the Assistant Secretary of the Army for Installations and Logistics.

One thing happened in this organization that I didn't realize would happen. I expected that I would be right up to my ears in defending the Army budget on the materiel side. This has not come to pass. Frankly, although I was surprised, I was not disappointed. The budget is rehashed so many times at so many different levels by so many people that it gets pretty well set in granite by the time it gets to the Congress. Then Congress takes its hammers and chisels and works away at it. I am just glad that I don't have to stand up there and pick up the pieces and try to put them back.

I would suspect that in the days and years to come, as the Army Materiel Command gets less embroiled in the problems of reorganization, and gets down more into the details of running its own job, that there will be a tendency perhaps to lean more heavily on the AMC for the defense of the budget. But at the present time, the Research and Development budget is handled by the Assistant Chief for Research and Development and the logistics budget is handled by DCSLOG.

You must remember too that my responsibility basically stops at the waterline in the United States. I have the terminal commands of the Army under me, and I load the stuff aboard the ship. My basic responsibility ends at the time that I put the materiel on the ship. It is DCSLOG's job, through the unified commands structure, to look over the logistics practices overseas.

Of course I have a moral responsibility which I can't shirk, which is to make sure that the equipment that I send overseas does, in fact, work. And, as a consequence, I have people overseas all the time in direct contact with the Army elements that are using the equipment that we send.

---

*for nearly five years, pioneering a number of concepts aimed at greater speed and efficiency for the transportation system. He carried these concepts still further after assuming command of the Transportation Center and School, Fort Eustis, Virginia.*

*From December 1954 to March 1958, General Besson was assigned to SHAPE, first as Assistant Chief of Staff, Logistics, and later as Assistant Chief of Staff, Programs.*

*In March 1958, he was appointed U. S. Army Chief of Transportation, a post he held until April 1962, when he assumed command of the newly established Army Materiel Command. Concurrently he was promoted to lieutenant general. AMC was activated in May 1962 and became operational in August 1962.*

*(The present paper was presented at USAMS, Fort Belvoir, Virginia, on 7 February 1964.)*

# ARMY MATERIEL COMMAND

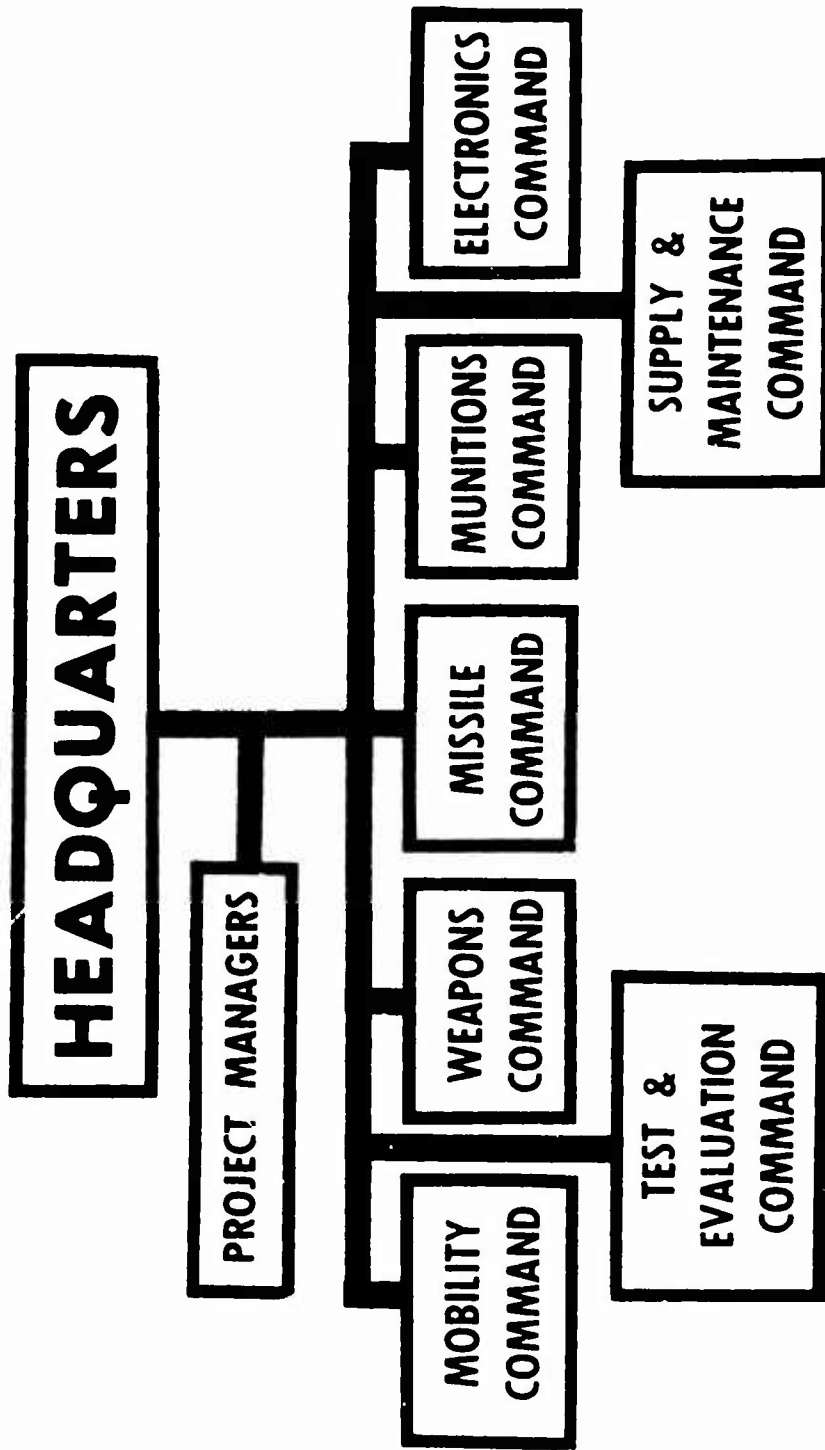

Fig. 3.

SOME FIGURES ON SIZE

Now to give you some idea about the size of the AMC, here are a few figures.

We spend about nine billion dollars a year. I support a materiel inventory in the hands of troops and in the depots of over \$18 billion. I started out with 186,000 people, of whom some 22,000 were military. That figure has gone down about 15,000 since I took command about a year and a half ago.

I have 233 installations and activities scattered around the continental United States, plus one in Alaska and one in Panama.

Just to give you an idea of what a billion dollars looks like, a million dollars in thousand dollar bills is seven inches high, so a billion dollars is about the height of the Washington Monument. I spend the height of the Washington Monument in thousand dollar bills, several times a year.

AMC ORGANIZATION

Figure 3 shows the way we are organized.

I decided that we would go on a commodity basis; that is, I would have a commodity manager responsible for everything having to do with a particular piece of equipment. In setting up AMC, I went along the traditional lines of the Army to move, to shoot, and to communicate. Five commodity commands cover the spectrum of Army materiel.

Under the Mobility Command are our aircraft and our general-purpose vehicles, our railroad equipment, our harbor equipment.

Under the Weapons Command come the tanks and the guns.

Under the Missile Command of course come the missiles.

Munitions, again self-explanatory, has responsibility for atomic munitions.

And, finally, the Electronics Command is the communicating command.

Backing up these five commodity commands is a Test and Evaluation Command, which is responsible for proving out the equipment developed by the commodity commanders. This is an independent check to insure that the equipment developed will in fact meet the needs of the user, and can in fact be utilized successfully in the field.

Then I have a Supply and Maintenance Command, which is responsible for bridging from the commodity commander to the user. He is the independent guy who makes sure that the commodity commander doesn't get so engrossed in materiel that he forgets the user.

The Supply and Maintenance Command is located in Washington, D. C., and, because of this, I departed from normal traditional lines

of organization in my own headquarters; and I have no supply and maintenance or transportation personnel in my own headquarters. I decentralize the responsibility for these actions to my Supply and Maintenance Commander. He, in fact, is my deputy in dealing with the commodity commanders on supply, maintenance, and transportation. He doesn't control what goes into the system. That is the responsibility of the commodity commander. But he does control how it is handled in the system, and what kind of procedures are used to translate it from the depot system into the hands of the users.

Up under my headquarters, I show an item called "Project Managers." I have introduced project managers into the AMC on a very important scale. I did this for several reasons. In the first place, project managership is a growing tool of modern management.

I borrowed what I could from the other Services. I talked to Admiral Rayburn who ran the Polaris system, which was the one real project managership in the Navy, and a very authoritative one, I must say. I talked with General Schriever and his people about how the Air Force Systems Command handled project managers through their SPOE system.

Basically, I would say that I borrowed something from both the Air Force and the Navy. I borrowed the authoritative control from the Navy, and I borrowed the broad scope of the utilization of project managers from the Air Force.

Another reason why I introduced project managers into AMC was because in picking up this new organization one of my primary considerations was to make sure that we did not drop the ball. I had a tremendous job in picking up installations and people and welding them into this new organizational structure.

You might be interested in knowing how we started in business, because it is an indication of how a simple approach works.

I said that a staff officer, which all of the people in Washington are, really does only three things. He either loses a piece of paper — and I said, "We are not going to do that in the AMC." So this leaves him only two things to do.

He either signs the piece of paper and tells somebody to do something, or he prepares a piece of paper for somebody else's signature. In simplest form, this is what a staff officer does.

I said that wherever these staff officers are, we will just change the name over the door. If they signed the piece of paper before, they will sign it now. If they prepared it for somebody else's signature, they will now prepare it for the signature of a nucleus which I have established in my headquarters.

# **CRITERIA FOR P/M**

---

- **MISSION CRITICALITY**
- **URGENT NEED BY USING UNITS**
- **COMMAND INTERESTS**
- **COMPLEXITY - ORGANIZATION OR TECHNICAL**
- **HIGH DOLLAR COSTS**

FIG. 4.

## PROJECT MANAGEMENT

Now, back to the reason why I have project managers. I found that project managers are in high repute in the top level of Defense, so I didn't see any reason why I shouldn't go along with them.

Another reason that I have project managers is to maintain the continuity of operations and the continued support of our military forces.

One way to do this, it seemed to me, was to put some people on top of certain of the important areas, so that I knew exactly who was handling those elements. And as you will see, I applied this to a very substantial portion of my business.

Finally, I guess another reason I have project managers is because almost everybody, including myself, wouldn't have given much for my chances of surviving this reorganizational procedure. And I decided that if I were going to go down, I was going to go down doing it differently. I didn't intend to go down just doing the same old thing.

Figure 4 lists some of the criteria that we have for establishing project managers. The essential thing to know about project management is that it is an exceptional system of management. You can't apply it to everything. It then no longer becomes exceptional; and, furthermore, the thing will fall apart from fracturization of your whole organization.

The points in the figure are fairly self-explanatory. What the criteria mean is that if an item warrants special attention — and you have to be careful what is given special attention — or if any one of these factors or any combination of them apply; if it is important that the item should be placed in an exceptional position where you give exceptional authority and look for exceptional performance; then we put the item under project management.

Items under project management change from time to time. We now have 33 project managers. They actually control expenditures of over a billion and a half dollars in PEMA and three quarters of a billion dollars in RDT&E. I have 3,184 people assigned to the project manager's staff.

About 640 million and 1.75 billion dollars, respectively, are my direct RDT&E and direct PEMA funds. About 50% of each of these programs is under the project manager's direction.

Some project managers report directly to the commodity command, and some report in to me directly. I will show you how they work in Fig. 5.

This illustrates the case where a project manager reports directly to me. Reporting to me, he is over my staff. There is a direct relationship between me and the project manager. He is responsible to me.

# PROJECT MANAGEMENT CASE I

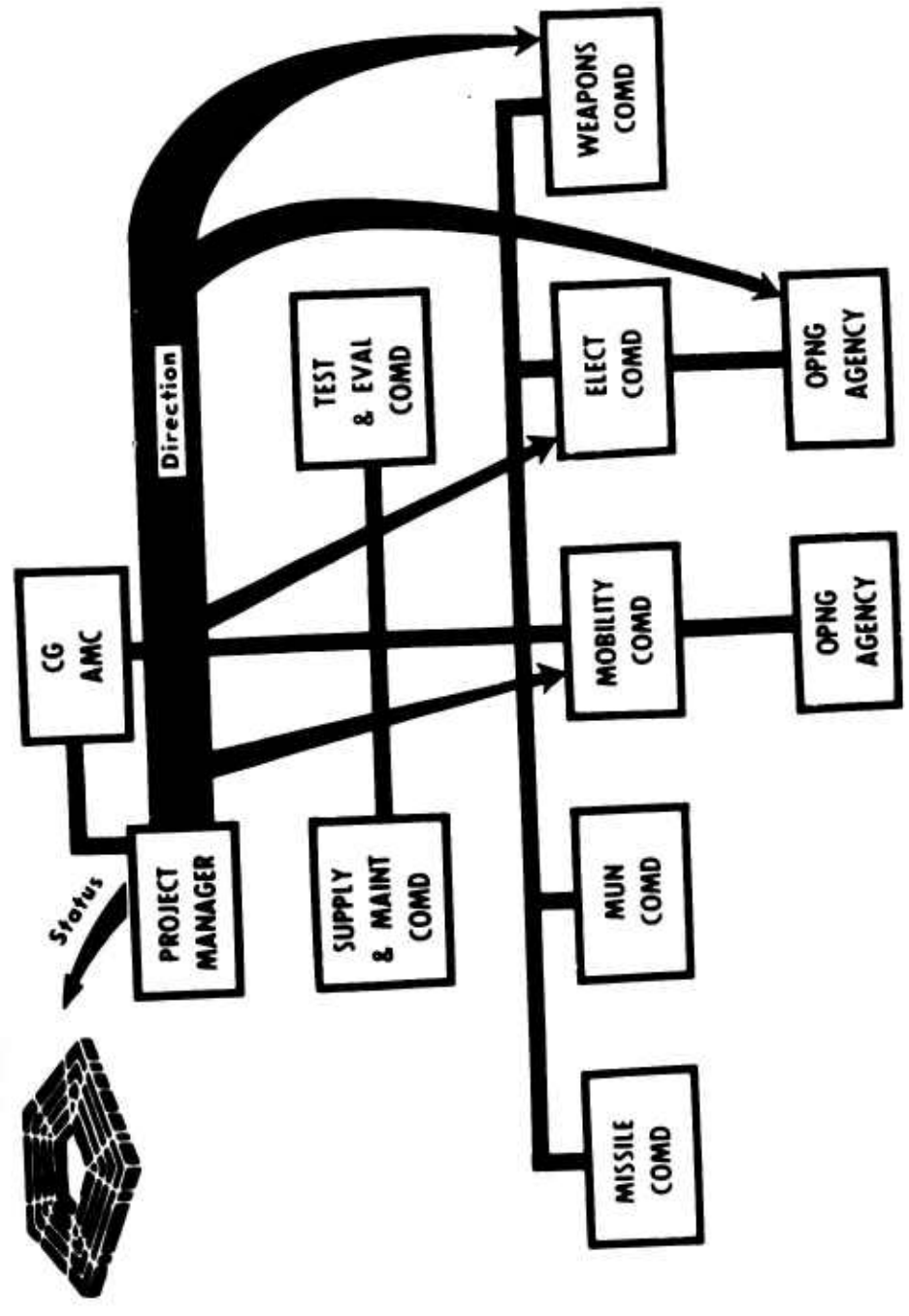

Fig. 5.

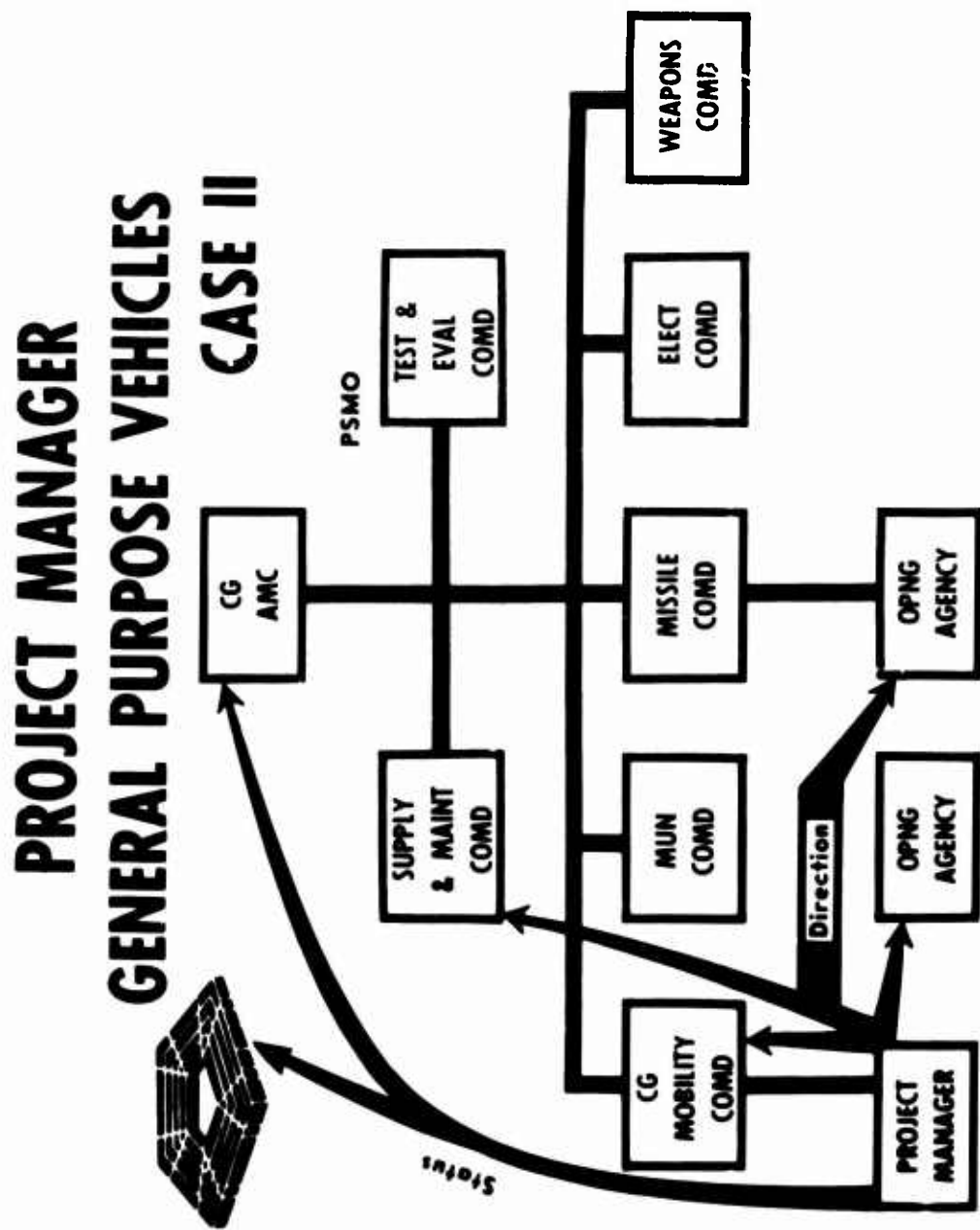

Fig. 6.

for the direction of the program. He has his own staff, a relatively small staff. It will run from 10 or 15 people, to the maximum — which is our Zeus project — of about 300. He has my authority to issue orders anywhere across the command to get his program done.

Now, he has to have a plan. He has a master plan which is approved. And this master plan is staffed. Under the master plan we establish the schedules and give him the resources that he is going to have to use. After that, he is on his own. I of course get weekly reports — highlight reports. And I get regular monthly reports on the schedule. But my staff is in the picture only so much as a project manager or I want to bring the staff in. The staff has no responsibility for supervision of the project manager.

A project manager under a commodity commander reports directly to the commanding general of that command (see Fig. 6). Here, again, the staff of that command is not over him. It is a one-to-one relationship between the project manager and the commander of the commodity command. Here, again, despite the fact that this project manager is in the subordinate command, he has my authority to issue orders across the board just as though he were reporting directly to me.

In exchange for this authority which I have delegated to him, he has a responsibility to come back to me and keep me advised if things are not going the way he wants. In effect, he has a more far-ranging responsibility than the commanding general of a commodity command, because he can issue orders to subordinate commanders in other commands. Therefore he has to be responsible to me because of this special delegation of responsibility.

Now the question is raised: Suppose he and the commodity commander don't get along?

Generally speaking, reasonable men looking at the facts come to the same conclusion. So I don't really anticipate difficulties, nor have I had serious difficulties, except in one or two instances between the project manager and the commodity commanders under this unusual relationship which I have.

The basic principle of the project manager, aside from the fact that it is an exceptional system of management, is that he has a staff. He is not an expeditor. That is what I found the Army had prior to the establishment of AMC. They called them project managers, but they weren't. They were merely expeditors — a man at a desk and a girl and a pencil and a telephone. My project managers are responsible. They get the money. They control the dollar resources, and when they go out to the other commodity commands, they go with a checkbook, and they order and pay for the resources that they are going to get out of that command. Because of this delegation of

authority, they have a responsibility back to me. They are directly wired in to me.

And I either write or endorse their efficiency reports.

People have told me about the problems of project managership. I remember at the very beginning, when they told me what the problems were going to be, they said that one of the problems was that the project manager was going to freewheel. Well, that's the reason he is put up there. So he can freewheel.

They said he would give some conflicting instructions at the bench level. By that, I mean that with all of these project managers cutting across the organization, everybody down the line would be hopelessly confused. The fact of the matter is that very few of these lines get down to the same depth, and even if they do get down to the same depth, the project manager doesn't cause the problem. The problem already existed. The fact that the project manager is looking at it merely brings it to light. He gets it out from where the staff tried to hide it, hoping it would go away, and gets it back up into the command channel where somebody, reluctantly or not, will have to take action to get it resolved.

They say that project management is an invitation to meddle. I am referring now to people like the Army Staff, and DOD, who could reach down and meddle in my business. Well, from what I have seen of Washington, you can't stop meddling. Consequently, I prefer to let them know where they can meddle and have it fixed and finite so that they go to the proper place to meddle. My project manager, like all the rest of my staff, is enjoined that he does nothing that anybody tells him except me. He doesn't have to accept guidance from anyone if it is contrary to his own personal beliefs as to how things ought to be done. But he is responsible to come to me and tell me when he doesn't agree with the instructions that he is getting from somewhere else.

So I can't stop the meddling; in fact, I encourage it. I subscribe to the theory that you don't have to take all the advice you get, but you are wrong if you don't get the best advice you can. And if there are smarter people topside, I would just as soon hear what they have to say.

My role in the command channel — I have already discussed that. Bypassing the command channel has not been a problem. My staff, my commanders, and my project managers have been living with this for over a year because we put this project manager system into being the first day I went into operation.

Of course, like any other system, it will rise or fall on the quality of the people that you have. I look forward to the day when the project managerships — assuming that this system survives, and I think that it will — will be a training ground for the future

generals, certainly in the logistics business of the Army. Many of my project managers are in that status at the present time. On the other hand, starting as quickly as we did, we were not able to get all of the people who were young enough and still had a future as generals in the Army, and we had to kind of go with what we had.

I have always had a philosophy, however, that if you take a man and give him the authority and the responsibility and tell him what you want done, you will be surprised at how well he will do the job and how a man will grow to fill the responsibilities placed upon him.

I have found this to be true, and the project manager system has been working extremely well. The comments that I get from industry are most favorable. In fact, project managership has gotten to be sort of a status symbol. If you are not a project manager, you are not really in the elite. This gets rather harmful, as a matter of fact, because I intend to introduce new project managers when needed, but as the project stabilizes, I want to put it back in the functional system. I find that the pressure is a little strong sometimes to keep me from turning them loose and putting them in the functional system again.

I will now talk a little bit about some of the things that we are doing outside of the actual organizational area.

We, like everybody else, are attacking Secretary McNamara's contract improvement program. We have goals in terms of cutting the amount of our cost-plus-fixed-fee contracts in half, stepping up our incentive contracts, and stepping up our firm fixed price contracts.

And this last year we pioneered in multi-year procurement.

What we do under a multi-year procurement is that we advertise for a one-year buy and then for an estimated two- or three-year buy. And we evaluate the prices based on the one-year vs. the three-year buy. Fundamentally, the difference between buying on a one-year and on a three-year basis is a saving of about \$3 million with reference to the  $\frac{1}{4}$ -ton tactical truck. The multi-year approach gives the contractors the opportunity to establish a continuous work schedule and plan. He has a firm basis for building up a work force and he is assured a continuity of production.

Of course we don't know that we are going to get the quantity that we prescribe for the ensuing two years. That is up to the budget makers and the Congress. So we have to set aside a certain amount of money for cancellation charges in case it doesn't go through.

Furthermore, we have a problem of how to take care of price escalation. Initially for the automotive industry, we just took a flat automotive index. But this didn't prove satisfactory, and this year we have adopted a new system.

Working with the Bureau of Labor Statistics we have a weighted index that we apply. We establish this index at the beginning of the contract and then we evaluate it each of the succeeding years that follow, modifying the contract according to certain factors, involving 40% for labor, 40% for materiel, and 20% for productivity and competition.

Next is the metal product index which was going down during the period.

The motor truck industry index has been generally on the down scale because of increased productivity. Despite the fact that wages and materials have been going up, the actual cost of motor vehicles has been going down. So this is the type of index, the composite index, that we use in adjusting the prices for the succeeding years on the contract.

Multi-year buys does several things for us: It stabilizes our business, it gives us better prices, and it reduces our workloads in the ensuing year.

To summarize what we have done in AMC, we imposed command control in the first year and a half. And within three months after we had taken over full responsibility for the technical services, we ran into Cuba, and we got through it, which was a real test. Too, we have established our project managers and have had continuity of operations.

I thought the first year of this job would be the hardest, but I found that this wasn't so. People were so concerned with the job that I had that they pretty well left me alone and let me run it. But now they are beginning to pay more and more attention to how I am running it and why I am running it the way I am. So I've got a big job of shaping up the area and the field organization. And I will end, then, by saying that it looks to me like the honeymoon is over.

## THE COMBAT DEVELOPMENTS COMMAND PROGRAM

Lieutenant General  
 DWIGHT E. BEACH  
 U. S. Army Combat Developments Command

It is certainly a pleasure to be with you today to tell you a bit about combat developments in the Army. During my presentation I will cover our responsibilities, the organization of the command, the procedures we employ to discharge our responsibilities, and our relationships with the Department of Army staff and the other major commands. I will also discuss a few of our projects.

### BACKGROUND

As a bit of background, I should initially like to give you a philosophical frame of reference which we have developed in the U. S. Army Combat Developments Command. Specifically, I want to emphasize the necessity for a complete marriage of the *products* of our most advanced technology and the best *doctrinal concepts* for the employment of these products. For it is patently obvious that superior weapons and equipment are of little value unless these items are brought to bear in the most effective manner possible. Similarly, new tactics to exploit an enemy's weaknesses will surely fail if our weapons and equipment cannot do the job required, if they are unreliable, or if they are so expensive and complicated that they cannot be acquired in sufficient numbers or operated and maintained by troops in the field.

The validity of this concept is amply borne out by even a brief review of our own military history. Such a review reveals very clearly the price we have paid for our failure to keep doctrine and technology in balance in past conflicts. For example, in the Civil War, the rifled musket and other improved weapons were many times more lethal than those used previously, but the organization and tactics employed by both the North and South were practically unchanged from the Napoleonic era 50 years earlier. Consequently, the war dragged on, and casualties were immense, primarily because doctrine lagged far behind technology.

*General Beach attended the University of Michigan prior to entering the U. S. Military Academy from which he graduated in 1925. He was then commissioned a second lieutenant. Field Artillery and active in the American Expeditionary Force in World War I he served with distinction in Europe and the Pacific.*

*Shortly after Pearl Harbor and the beginning of World War II General Beach was transferred to the Southwest Pacific where he served with distinction in the*

World War I showed the same failure — and more vividly. Technological advances made the machine gun, aircraft, gasoline-powered vehicles, telephones, and radios available. During the conflict the British developed the first successful tank, a weapon which could have overcome the dominance of the machine gun, but they failed to exploit its great potential. Similarly, the Germans developed poison gas but never fully utilized its capabilities until counter-measures were produced — and then it was too late. The machine gun dominated the battlefield. Four years of stalemate bled the major participants white, again because neither side could, or would, capitalize on technology with new tactics, at least not to the extent of swinging the balance.

Between World Wars I and II, we in the American Army developed very effective techniques for the massing of artillery fire, and we were most proud of that accomplishment. But consider what was necessary to do this: A long-range gun, available since the Civil War; accurate survey, also long available; and a fast reliable means of communication, available since the telephone was invented by Alexander Graham Bell and in wide use since about 1900. In other words, our development of this artillery doctrine lagged technology by at least 30 years.

World War II, on the other hand, shows what can, and does happen when one side melds advanced technology with advanced doctrine while the opponent fails to do so. The startling success of just a handful of German Panzer divisions supported by Stuka formations and employing tactics which were questioned even by some members of the German General Staff is too well known to bear repeating. On the other hand, the Allies developed highly effective techniques for landing large attacking forces on hostile shores — most dramatically demonstrated in Normandy. World War II shows, at different stages and on different sides, the great military advantage which

---

*167th Field Artillery Battalion. His unit in the 41st Infantry Division participated in campaigns in the Southwest Pacific area from Australia through New Guinea to the Philippines and Japan. In the Philippines he became Executive Officer of the 24th Division Artillery.*

*Since World War II he has commanded the artillery of the 11th Airborne Division, the artillery of the 45th Infantry Division in Korea, and served as Artillery Officer and Deputy Chief of Staff for Plans and Combat Operations, 8th U. S. Army, in Korea. In November 1954, he was appointed Chief of Staff of that organization.*

*Following Korea, General Beach was assigned to USCONARC as Director of the Office, Special Weapons Development. He was then assigned to the DA in the Office of the Deputy Chief of Staff for Military Operations as Director of Guided Missiles.*

*He commanded the 82d Airborne Division, Fort Bragg, North Carolina, from June 1959 to April 1961. In May 1961 he returned to the Pentagon as the Deputy Chief of R&D.*

*In July 1962, General Beach was promoted to the rank of lieutenant general and assumed the duties of Chief of R&D. He was designated Commanding General, USCDC, in August 1963.*

*(The present paper was presented at USAMS, Fort Belvoir, Virginia, on 20 March 1964.)*

accrues to the force which capitalizes on technological progress by the adoption of doctrinal advances.

From these examples, it is clear that success has generally come to the side which has taken advantage of technology and formulated appropriate doctrine to exploit it. It is the job of my command to insure that the U. S. Army does just that.

With this background, let me now define exactly what we mean by combat developments, for I find the term is widely misunderstood.

#### COMBAT DEVELOPMENTS—A DEFINITION

*Combat developments* are the formulation of new Army doctrine, organizations, materiel objectives and requirements, and the early integration of the resulting products into the Army (AR 71-1).

Note that the combat developments process covers the whole gamut from the generation of ideas to the integration of advanced hardware, new organizations, and improved doctrine into units in the field.

This definition, when applied to my command, can be misleading. This is the specific mission of the CDC:

- To command all assigned field agencies;
- To formulate and document current doctrine for the Army; and
- To determine the type of forces and materiel needed in the future, and how these forces and materiel should be employed.

Note the third point. We *do not* develop the hardware, train the troops, or determine how many are needed. These missions belong to other agencies. In simplified form, our mission is, basically, to answer three questions:

- How should the Army fight?*
- How should the Army be equipped?*
- How should the Army be organized?*

How well the CDC solves these three questions may well determine the success of our Army next year, five years from now, or as far into the future as we can predict.

In the past, this task was theoretically performed by many different elements of the Army: service schools, parts of the offices of the chiefs of the technical services, and so on. As many of you recall, the CDC was created in July 1962 at about the same time as the Army Materiel Command, and was designed to consolidate all of the combat developments activities then being performed by many different elements and echelons of the Army. The objective was to place these wide-ranging responsibilities under the control of a single

commander who would be immediately responsive to the Army Chief of Staff.

#### AN EXTENSIVE PROGRAM

To accomplish our job, we have an extensive, detailed program. The end products of my command's efforts are field manuals, which prescribe doctrine, and tables of organization and equipment, which, for each type of unit, prescribe the total number of personnel and the amount and kinds of equipment that unit should have. To arrive at these results, we conduct studies and establish the materiel objectives and requirements necessary to obtain the desired operational capability. Of course we also monitor the development of hardware by the Army Materiel Command, and the other developing agencies.

The CDC obviously cannot, and does not, operate in a vacuum. Many agencies are involved and our relationships with these agencies can become quite complex in the details of execution. But our basic responsibilities and relationships are fairly simple. In general, we can say that the DA provides guidance for our efforts and sanctions our results by approval for implementation.

#### RELATION TO OTHER MAJOR COMMANDS

With respect to the other major commands of the Army, the CDC acts as a catalyst for combat developments within its assigned areas of responsibility. (See Fig. 1.) In passing, I might mention that we are the smallest major command in the Army. We are authorized just under 6,000 people and have an annual budget of only about 25 million dollars. But our responsibilities are *not* small, as I hope to point out. As depicted in the figure, the CDC functions as the user representative for the U. S. Continental Army Command (USCONARC), the continental armies and our oversea commands. It relies upon the field for review and testing of proposed changes in doctrine and organization, and for additional input of new ideas into the system.

The U. S. Army Materiel Command (USAMC), on the other hand, as the major operating command for the development and production of hardware, furnishes us an estimate of anticipated technological progress, in the form of technological forecasts for the next 20 years. This forecast is used by the CDC to assist us in the establishment of materiel requirements which are within the realm of expected feasibility. In addition, when the CDC establishes a materiel requirement, the AMC provides input almost from the beginning. When the materiel requirement receives DA approval, the AMC, either in-house or by contract, does the necessary research and development to

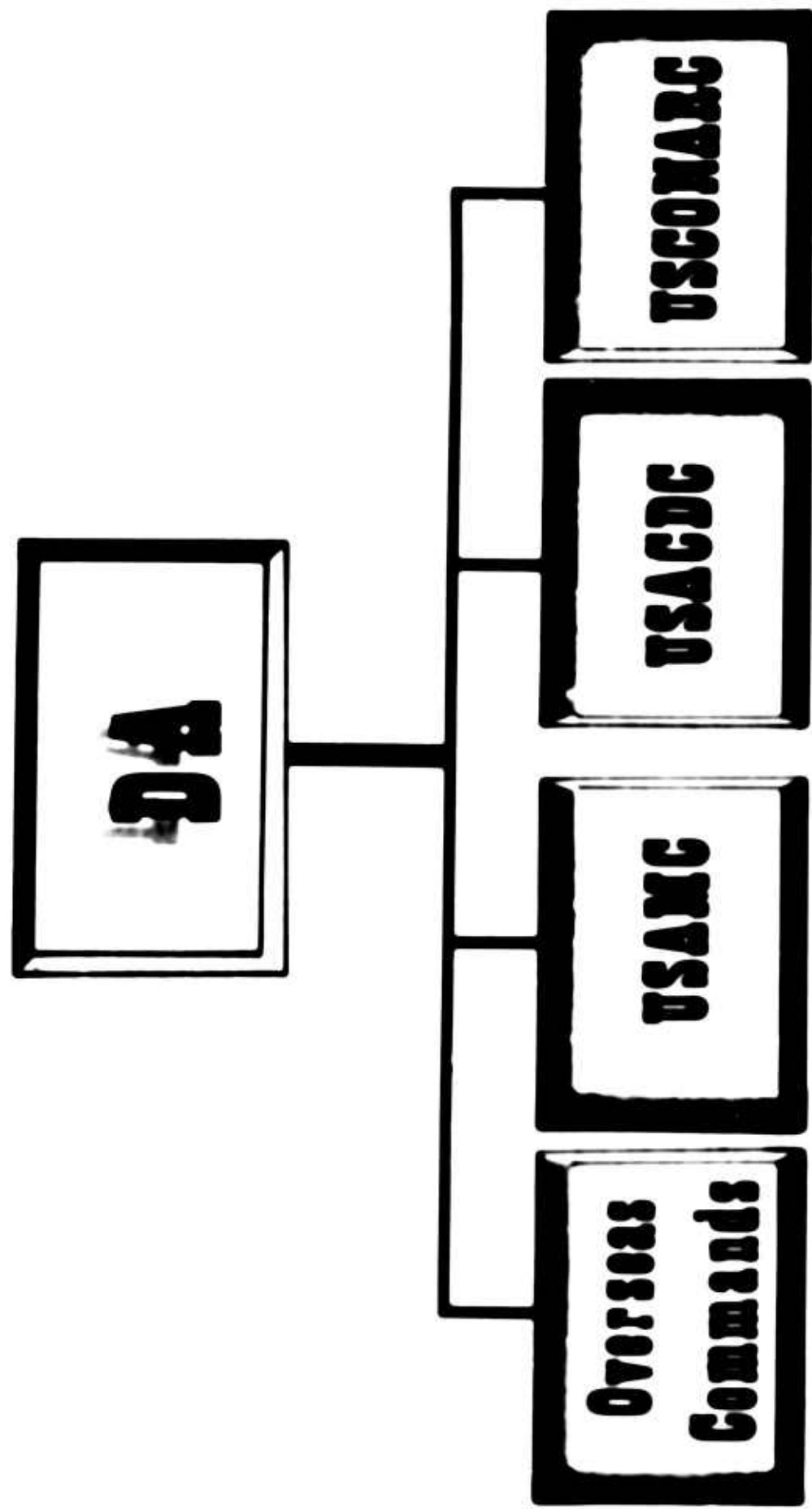

Fig 1

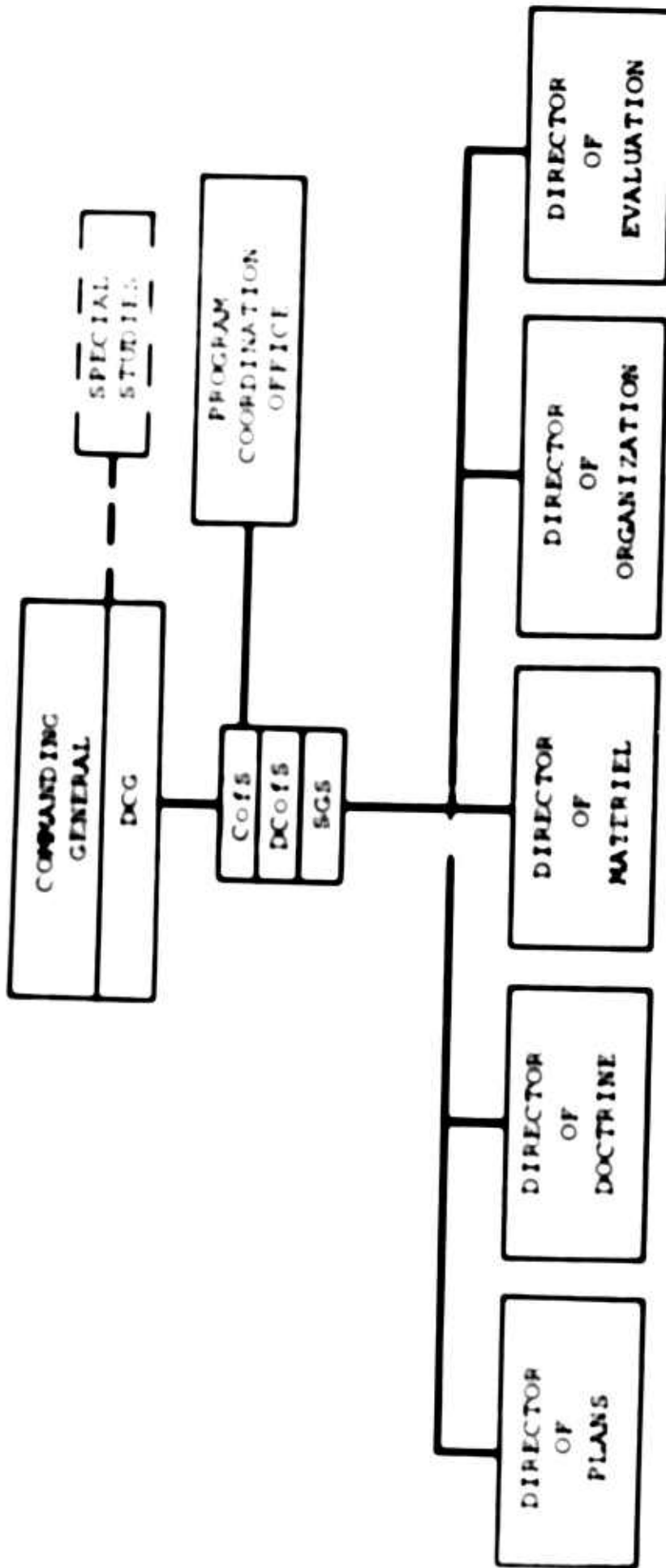

Fig. 2. Headquarters, CDC.

produce the piece of hardware. There are many checkpoints in the materiel developments process between our two commands to insure that the end product meets the stated need.

#### ORGANIZATION

Now let me show you our organization to accomplish our mission. (See Fig. 2.) This is my headquarters at Fort Belvoir. It consists of a command group, an Office of the Chief of Staff, and five functionalized directorates. Though not shown, there are also the usual administrative services.

Note on the upper right of the figure that a special studies element has been established to provide us a capability to conduct the numerous special studies which we have been assigned. Since activation, with the exception of 10 days, we have had some type of *ad hoc* study underway. These studies have been assigned to us by DOD and DA. They almost always require resources from outside the CDC, so we have set up a special element to handle this kind of action.

The *Director of Plans* develops the basic policy guidance and general objectives that establish the direction of the total combat developments effort for the future. He is responsible for broad futuristic conceptual studies for the post-1980 period. He derives guidance from the DA plans and, in turn, generates input for these plans.

The *Director of Doctrine* has staff responsibility for determining "how the Army should fight," and the broad concepts of how it should be organized.

The *Director of Materiel* has staff responsibility for determining "how the Army should be equipped"; in other words, developing our materiel objectives and requirements.

The *Director of Organization* has staff responsibility for determining "how the Army should be organized," producing detailed organization documents based upon approval concepts and also determining the bases of issue for equipment.

The *Director of Evaluation*, through the use of scientific methods and principles, such as war gaming, operations research, field experimentation, and troop tests, determines whether the concepts and materiel developed are sound and appropriate for incorporation into the Army. He, in effect, keeps the four other directors honest.

#### SUBORDINATE COMMANDS

To collect, sort, collate, and evaluate conceptual data and reduce them to recommended materiel requirements, doctrine, and organizations, the CDC has seven subordinate commands and one special group

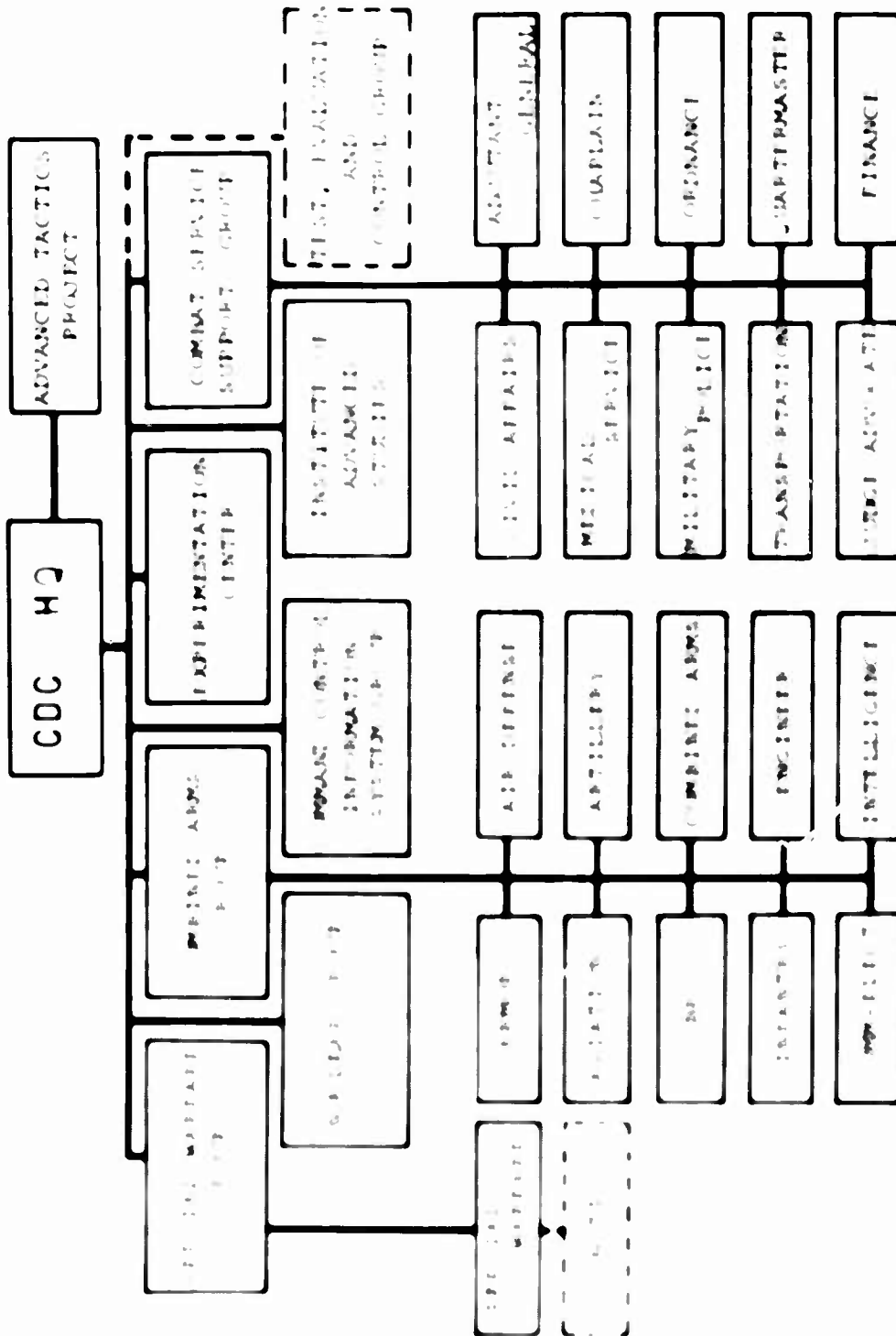

Fig. 1. CDC Subordinate Organization.

located throughout the continental United States. These subordinate elements are shown in Fig. 3.

The *Special Warfare Group*, located at Fort Belvoir, Virginia, concerns itself with activities in support of special warfare and counterinsurgency operations by both indigenous and United States Forces. The subordinate agency of this group is the Special Warfare Combat Developments Agency at Fort Bragg, North Carolina. It also has direct contact with ACTIV, the Army Concept Team in Vietnam.

The *Nuclear Group* at Fort Bliss, Texas, works on nuclear energy matters concerning Army employment of nuclear weapons and other nuclear devices and the defense against nuclear weapons used by the enemy.

The *Combined Arms Group*, collocated with the Command and General Staff College at Fort Leavenworth, Kansas, commands the field agencies shown. It develops current and future doctrine and materiel for the combat and combat support elements. The Commandant of C&GSC is also the commander of the Combined Arms Group.

The *Command Control Information Systems Group*, located at Fort Belvoir, Virginia, with a subordinate office at Fort Huachuca, Arizona, conducts our program for the development of data-processing equipment and related systems to reduce reaction time during combat operations.

The *Combat Developments Experimentation Center*, familiarly known as CDCFC, is located at Fort Ord, California. The center serves as a field laboratory for the evaluation of concepts and operations, both tactical and administrative. It has an organic capability to conduct field experiments through battalion level and is supported on a contract basis by the Stanford Research Institute. I might mention that two thirds of our personnel strength is committed to the Experimentation Center.

The *Combat Service Support Group*, at Fort Lee, Virginia, commands the agencies shown. It performs functions similar to those of the Combined Arms Group, but in the area of logistics and combat service support matters.

The *Army Institute of Advanced Studies*, collocated with the Army War College, is responsible for preparing very long-range conceptual studies on the broad international, national, and departmental level. These studies deal primarily with the organization, employment, and strategic operations of the theater army and major subordinate elements above field army level. Included also are studies on joint operations.

The *Test Evaluation Control Group* is a subordinate agency located at Fort Benning, Georgia. It has the mission of drawing up the

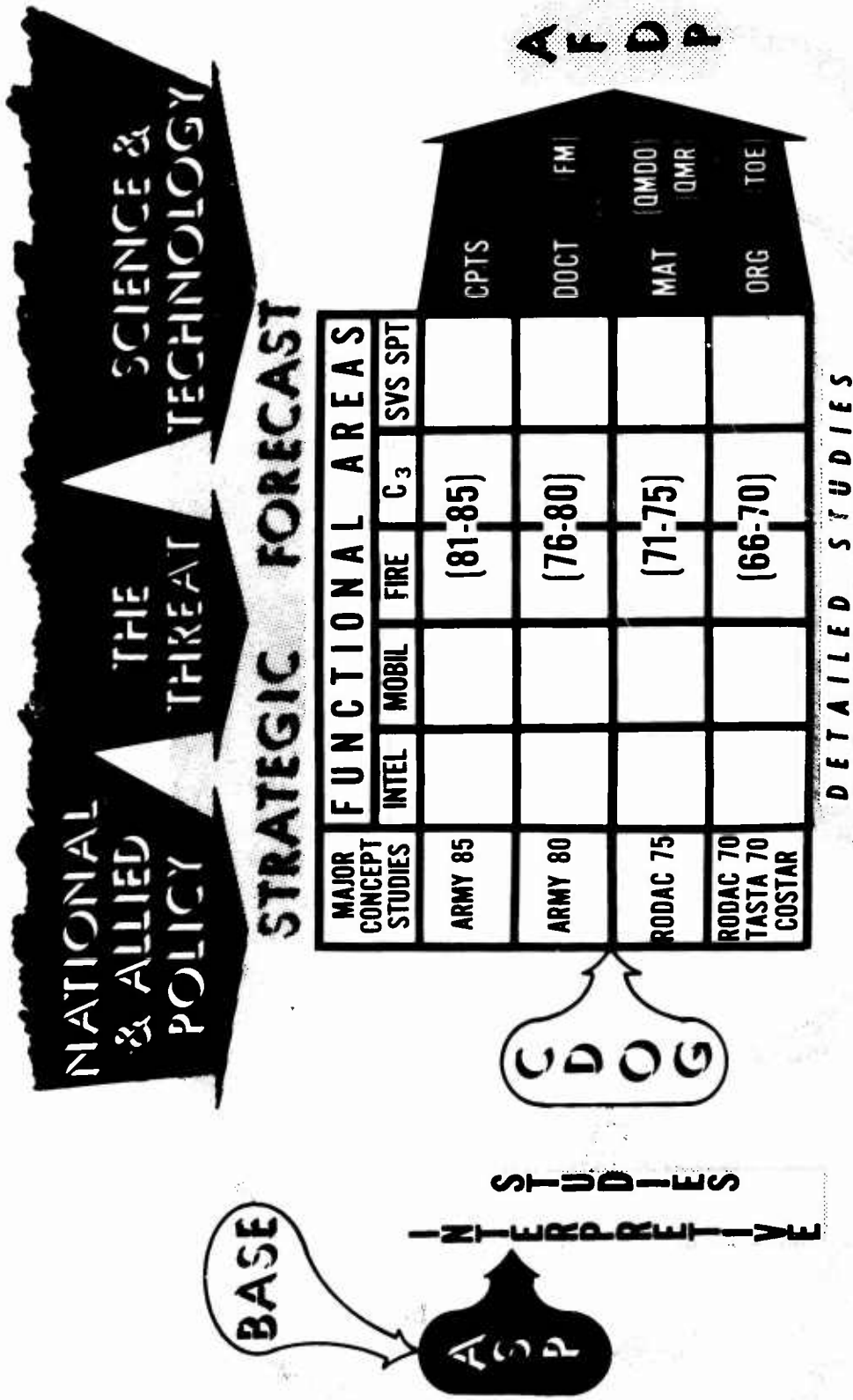

Fig. 4. Pattern for combat developments.

detailed test plans for the 11th Air Assault Division, controlling the tests as conducted, and evaluating the results. I will discuss this program in greater detail in a moment.

Please note the geographic dispersion of the many elements of the CDC. Almost all of the CDC field agencies are collocated with their respective service schools, the Quartermaster Agency being with the Quartermaster School, for example. Though entirely separate from the schools, organizationally, these agencies of CDC work closely with the schools to insure compatibility of instruction and doctrine, both present and future.

So much for our organization. Now, let me discuss how we operate. We receive our guidance for our work from DA through the medium of approved plans.

#### PATTERN FOR PLANNING

In Fig. 4 you see a schematic of the methodology we employ to discharge our assigned responsibilities. We call it our pattern for the combat developments. We obtain our directions initially from the Basic Army Strategic Estimate (BASE) and the Army Strategic Plan (ASP). We translate this guidance through interpretive study into general objectives which, upon approval, are included in the Combat Developments Objectives Guide (CDOG), which is, in effect, a catalogue of our program.

Now, let us look at the matrix which is the heart of our pattern for combat developments.

The vertical axis depicts the timeframe from the present out to 20 years in the future. We have arbitrarily broken this 20-year period into 5-year increments for administrative control purposes, and also because past experience indicates a 5-year period seems to be a reasonable period to study. On the horizontal axis we portray the functional areas which are considered basic to Army operations. These are intelligence, mobility, firepower, command control and communications (shown as  $C_3$ ), and service support. Each of these functional areas is further subdivided into detailed study areas, the sum total of which should provide the complete coverage of that functional area.

There is nothing magical about these subdivisions; we arrived at the five functional areas shown after much debate and analysis. There can be almost as many solutions as there are people to contribute; however, the objective was to find functional areas under which related aspects could be grouped. For example, in the " $C_3$ " area we include under "Command" such aspects as professional knowledge and leadership ability; under "Control" such aspects as organization,

training, and discipline; and under "Communications" all those systems needed to provide for command and control from arm and hand signals to automatic data processing.

Now, in using this pattern for planning, our basic problem is to blend the detailed specialized knowledge in each portion of each functional area into a total concept; and, conversely, to insure that the specialized aspects are in consonance with the total concept.

We use the common basis established by the DA plans and the CDOG for the orientation of our effort. It is obvious that this orientation is more specific in the nearer timeframes than it is in the long-range periods. In all cases, our detailed studies, which can be considered as specialized studies, extend as far into the future as possible. Within this overall framework, current structures, equipment, and materiel under development serve to guide our study effort in the closer timeframe — and technological forecasts and broad Army objectives for the more distant timeframes.

The major concept studies, shown on the left of the matrix, using the materiel available in the detailed studies, combine these elements into a total concept in which the component parts must be compatible. Where detailed studies are not available, the final major concept study must either develop the necessary coverage or highlight the fact that a detailed study in these specific areas is required. In this way detailed studies have an impact upon broad concept studies and *vice versa*.

The major concept studies in the 0- to 5-year timeframes usually take the form of an organizational study. This is exemplified by the studies shown here as RODAC-70 (*Reorganization and Objectives Division, Army Corps-1970*), COSTAR (or *COmbat Service to the ARmy*), and TASTA (or *The Administrative Support, Theater Army*). These studies draw together the organizational and operational concepts and the materiel under development, and thus provide the basis for our programming of field manuals; tables of organization and equipment; small development requirements; troop tests; and, sometimes, field experiments.

Our broad concept studies for the 5- to 10-year period, such as RODAC-75, for the 10- to 15-year period (Army 80), and the 15- to 20-year period (Army 85) are designed to blend, hopefully in an orderly development, the concepts for the 0- to 5-year period all the way out to 20 years hence.

This matrix, then, provides us with a system to coordinate, control, and assign priorities to our projects. The output of our studies in the form of concepts, objectives, materiel requirements, doctrine, and organizations provides input into the Army Force development Plan (AFDP), which, in the shorter range coverage, results in guidance for the Army Five-Year Force Structure and Financial Program for the next five years.

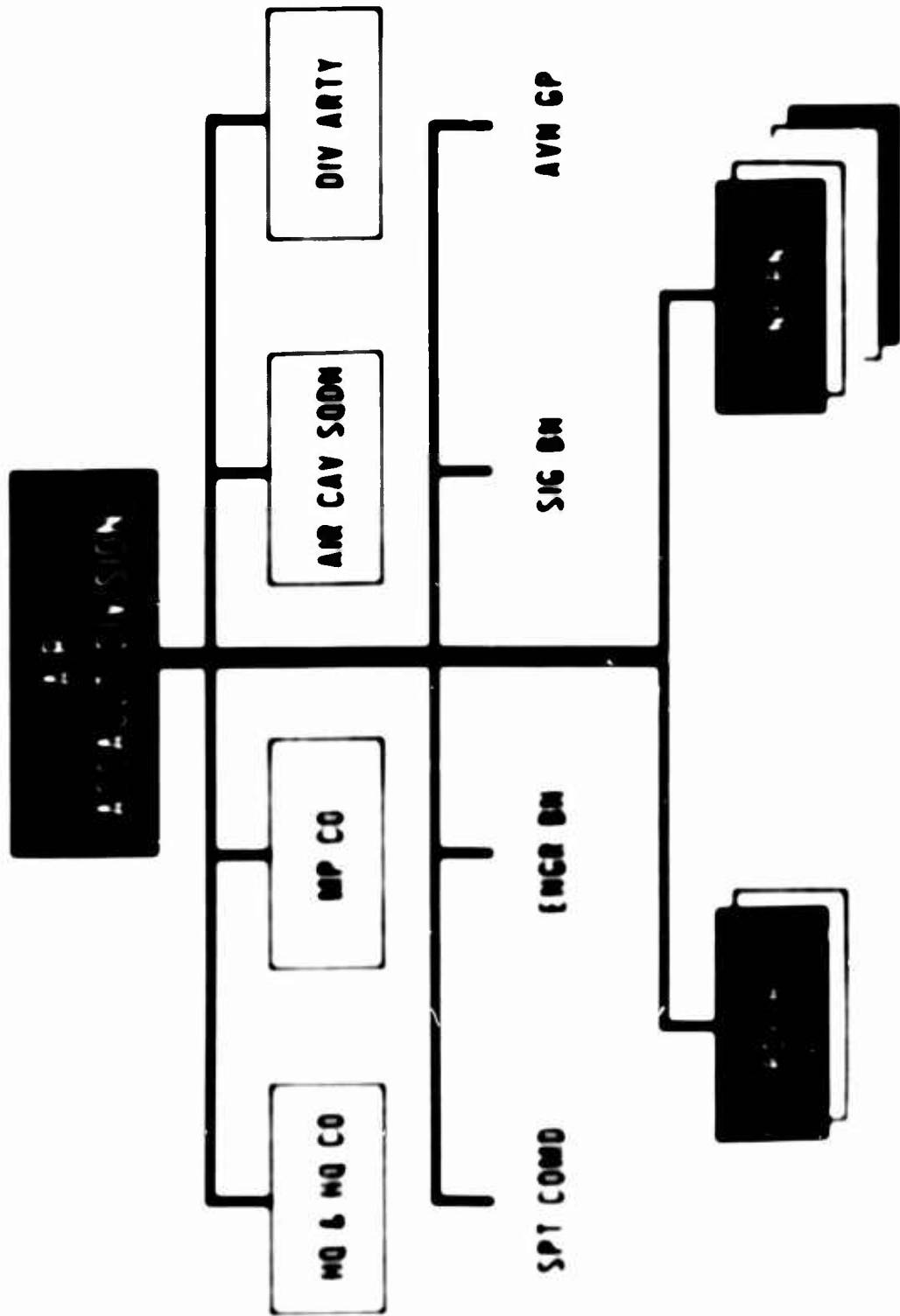

Fig 5

All together, these actions provide feedback into the basic Army plans. This, then, is the methodology used to program and control our combat developments program.

#### SOME CURRENT STUDIES

Next, I want to discuss in some detail some of our current studies. First, there is the Army Tactical Mobility Program, begun by a study conducted by the Howze Board two years ago. The CDC has been given the responsibility for continuing the actions initiated by the Howze Board. As you know, that board took a bold new approach to the problem of mobility and came up with recommendations for the testing of three new organizations: the Air Assault Division, the Air Transport Brigade, and the Air Cavalry Brigade.

The Air Assault Division is now undergoing organization, training, and testing. Phase I was the organization, training, and testing of a battalion-size force. This has been completed.

Phase II is the organization, training, and testing of the division. Further tests will be conducted in October and November of this year. Aside from the activities of the Test, Evaluation, and Control Group I discussed earlier, we also have a mammoth effort — studies, war games, and field experiments — being conducted by almost every element of my command as we look into all aspects of air mobility for the Army.

#### AIR ASSAULT DIVISION ORGANIZATION

The organization of the Air Assault Division currently being tested is as shown in Fig. 5. It is organized functionally and on the building block principle.

For example, there are eight identical infantry battalions and three identical brigade headquarters. The other organizations of the division are similarly structured, thus enabling the tailoring of brigade forces to cope with varying situations. In this way, it resembles our current ROAD divisions. However, the equipment and employment vary from ROAD. The most noticeable differences are the few land vehicles and the many air vehicles. In the current tests the division will have about 16,000 men and 459 aircraft. It will be able to move about one third of its assault forces by air at one time. These aircraft include 30 Mohawks, 293 Iroquois, 48 Chinooks, and 88 light observation helicopters.

Tests conducted to date show problems and promises, but the final evaluation will not be available until the tests are completed.

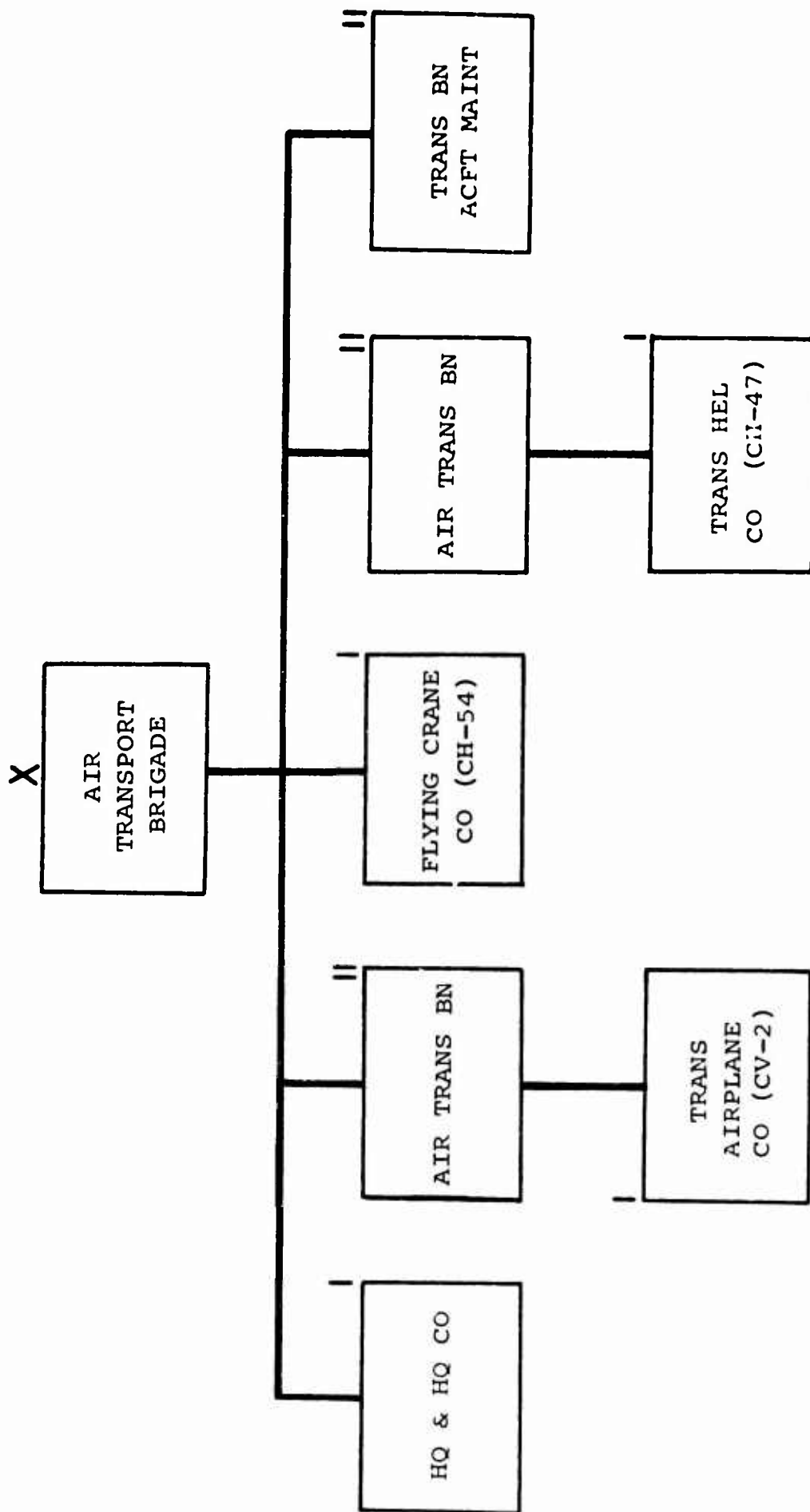

Fig. 6.

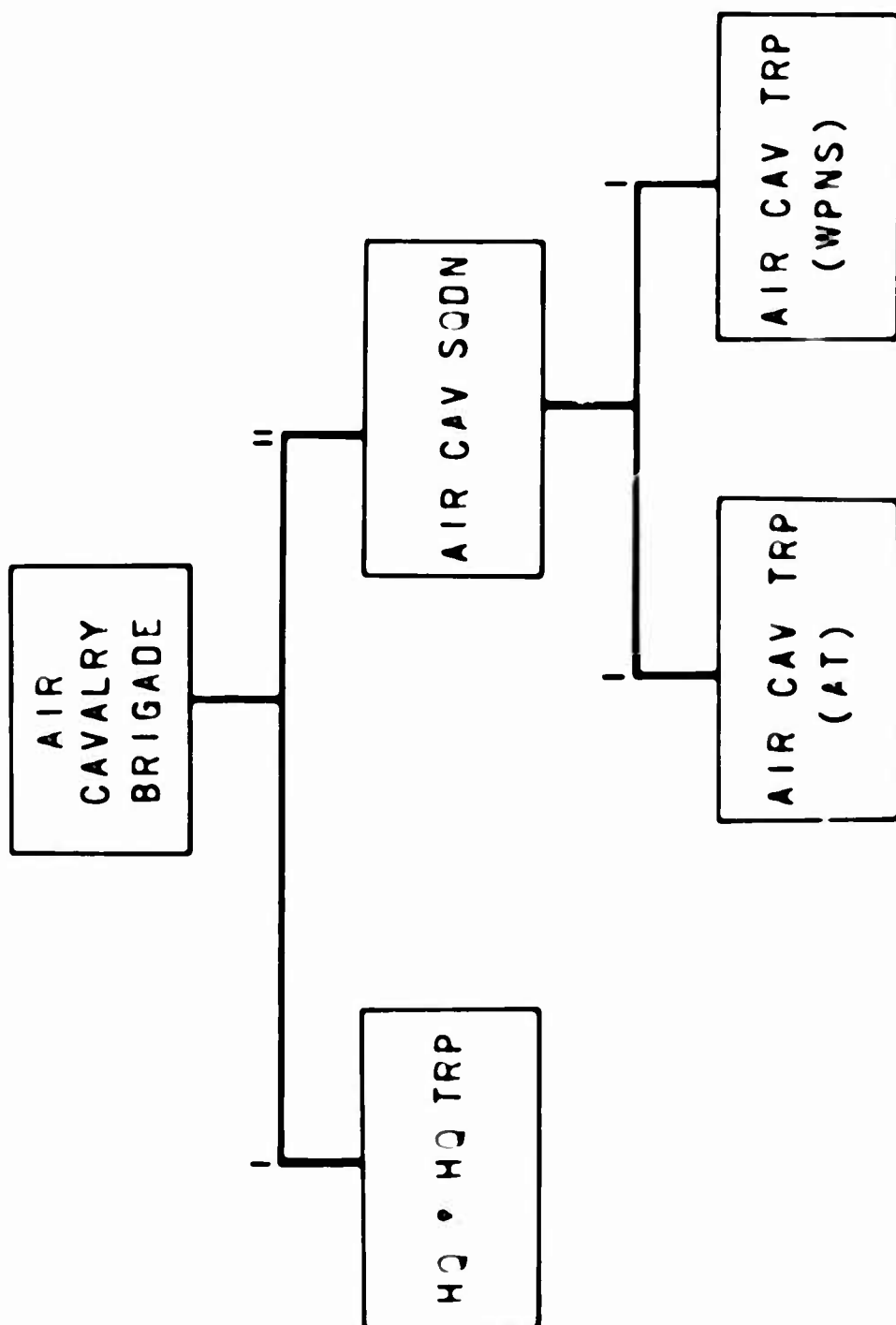

FIG. 7

**AIR TRANSPORT BRIGADE ORGANIZATION**

Figure 6 shows the organization of the experimental Air Transport Brigade. As envisioned, the Air Transport Brigade would supplement the air lift support provided by the Air Force and also provide an airline of communication from the division to its brigade and battalions. For the current tests this unit will have about 3,500 men and 130 aircraft. Its air vehicles will include 80 Caribous, 32 Chinooks, and 9 Flying Cranes. It will be capable of lifting about 3,500 troops or 400-500 tons of cargo, for a 100-nautical-mile radius in a one-time lift at sea level. The experimental Air Transport Brigade is now being organized.

**AIR CAVALRY BRIGADE ORGANIZATION**

The anticipated organization of the test Air Cavalry Brigade is shown in Fig. 7. Although such a brigade has not yet been organized, it is intended to be a hard hitting, highly mobile outfit with about 2,500 men equipped with 276 aircraft. These are 92 light observation helicopters and 184 Iroquois.

These, then, are the organizations we are studying in our efforts to increase our organic air mobility.

**COMMAND CONTROL INFORMATION SYSTEMS**

The objectives of the CCIS program are:

To develop automatic data-processing techniques for the Army in the field which will result in significant operational gains through reduction in reaction time.

To provide compatible automatic data-processing systems at acceptable cost in terms of men, money, and equipment required.

And, to integrate various automated functional areas on a time-phase basis where it appears feasible and desirable to do so, thus permitting a gradual phase-by-phase introduction of the systems into the Army in the field.

An automatic data-processing subsystem is envisioned for each of these functional areas:

- a. Operations.
- b. Fire Support.
- c. Intelligence.
- d. Logistics.
- e. Personnel and Administration.

The Operations Subsystem will automate certain functions to assist the commander in monitoring and controlling the tactical situation.

The Fire Support Subsystem provides for automation of selected artillery functions to enable the commander to use the fire support provided his force in the most effective manner.

The Intelligence Subsystem will enable improvement, both in timeliness and accuracy, of the production and dissemination of tactical intelligence.

The Logistics Subsystem will extend automatic data processing to selected logistics functions of combat service support in the field army, and the Personnel and Administration Subsystem will automate selected functions of the administrative elements of the field army.

#### LOGISTICAL SUPPORT ORGANIZATIONS

**COSTAR** stands for "Combat Service to the Army." It is a logical extension of the functionalized ROAD Division service support concept as opposed to the current technical service support provided. The objective is to develop a simplified combat service support structure within the field army.

To accomplish this objective a Field Army Support Command (**FASCOM**) is established to provide a command-type organization responsible for combat service support of the field army, less personnel replacements, communications, and construction. The **FASCOM** consists basically of a headquarters, an inventory control unit, Army-wide services, and support brigades.

The mission of the support brigade is to provide field maintenance, supply and service support to divisional and nondivisional units in a corps slide. The mission of the direct support group is to provide maintenance, supplies and/or services directly to nondivisional units assigned or attached to the field army.

They are similar in many respects to the structure of the ROAD Division Support Command, and in essence, the DS group is a nondivisional support command established for support of field Army non-divisional units.

The mission of the General Support Group is to provide back-up supplies and/or services to divisional and **FASCOM** direct support units. In **COSTAR** the General Support Group will probably also be functionalized.

**TASTA** stands for "The Administrative Support, Theater Army." **TASTA** extends the new functionalized concept of service support to the Communications Zone, and encompasses both the field army and the Communications Zone.

OBJECTIVES AND REQUIREMENTS

Now, based upon the results of studies such as the ones I have just described, we develop new or revised doctrine which we include in field manuals. Our new organizational concepts are the basis for new tables of organization and equipment, and our materiel objectives are refined into Qualitative Materiel Development Objectives, Qualitative Materiel Requirements, and Small Development Requirements.

Let me explain the difference in our statements of materiel objectives. The Qualitative Materiel Development Objective, or QMDO, states a requirement for an item whose technical feasibility is unknown. The Qualitative Materiel Requirement, or QMR, states a requirement for an item which is technically feasible. Lastly, the Small Development Requirement, or SDR, states a requirement for an item which is technically feasible but which is of a lesser magnitude with respect to cost, complexity, and lead time than a QMR. Most of our training devices and conventional ammunition fall into the category of SDR.

Let's examine for a moment the preparation and coordination of statements of requirements.

Regulations provide that a draft statement of a materiel requirement may be initiated by any organization or individual, one of you, for example, and that the CDC will review and refine these statements as necessary to obtain DA approval. Most of our statements of requirements originate within the command; however, approximately 20 percent of the requirements received by CDC since its activation have been initiated by organizations or individuals outside the command. Most of our small development requirements for training devices, for instance, are originated by elements of USCONARC.

To illustrate the routing and processing of materiel requirements I have selected the qualitative materiel requirement for the new Main Battle Tank. (See Fig. 8.) This QMR was selected because it was one of the first for a major system to be completely processed subsequent to the activation of the CDC. Although the development of the tank is a joint undertaking, in discussing the QMR I shall refer only to the procedures followed on the U. S. side.

In December 1962 the CDC Armor Agency at Fort Knox completed preparation of a draft QMR for a new Main Battle Tank which would be superior to the current M60 tank in firepower, mobility, and battle-field survivability. The Armor Agency drafted the organizational and operational concepts and the definitive characteristics of the new tank. The agency then informally coordinated the draft QMR with other CDC agencies and with the Armor School and the Armor Board. As a result of this coordination, some draft characteristics of the new tank were added or changed. Also, the technical feasibility of the

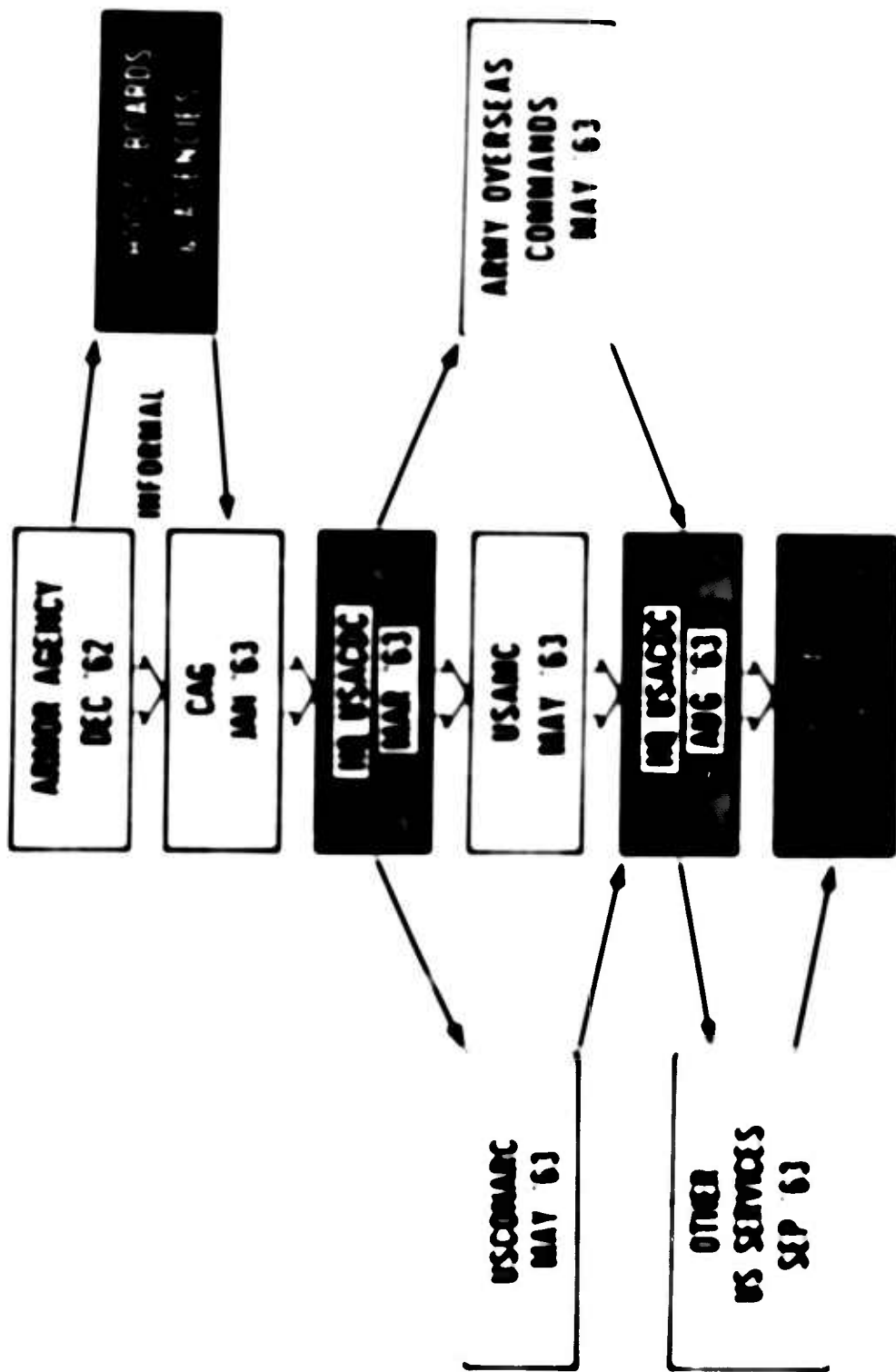

Fig 8 Qualitative materiel requirement for main battle tank

new tank was established tentatively by the Armor Board. In January 1963 the draft QMR was sent to the CDC Combined Arms Group where it was coordinated with the Combat Service Support Group. As a result, additional information concerning logistical implications and maintenance of the new tank was inserted into the draft QMR.

When the QMR arrived at Headquarters, CDC, early in March 1963, it was checked for conformity to applicable concepts and detailed studies and to administrative requirements. Then, in May 1963, it was sent to USCONARC, which stated that the training considerations were adequately covered in the QMR. At the same time, the draft QMR was sent to the Army Materiel Command, which verified that the system was technically feasible and stated that it could be produced without significant effect on the production of other essential items of materiel and without excessive use of critical materials. Simultaneously, the draft QMR was coordinated with US Army, Pacific; US Army, Europe; US Army, Alaska; and US Army Forces, Southern Command. Although there were some minor changes in the characteristics contained in the draft QMR as a result of the coordination with the various oversea commands, there were no major divergencies in their views.

The comments of CONARC, AMC, and oversea commands were received at intervals until August 1963. Each comment was considered and correlated with the draft QMR and with all other comments, and the proposed QMR was prepared in final form. On 4 September 1963 it was sent, along with the comments which were not incorporated of other major commands to Headquarters, DA. At the same time, it was provided to the US Navy, the US Marine Corps, and the US Air Force for formal review and comment directly to Headquarters, DA.

The proposed QMR was subsequently approved by Headquarters, DA, and Maj Gen Welborn G. Dolvin, US Army Materiel Command, was named U S project manager for the development of the tank. The development effort is being conducted jointly by the United States and the Federal Republic of Germany.

This is an example of the process which a QMR goes through upon initiation or receipt in the CDC. The processing of a QMDO or a SDR differs only in detail. Of course there is a breakpoint between a QMDO and a QMR. This breakpoint is reached when we get information that an item called for by a QMDO is now known to be technically feasible. We then verify that the need for the item still exists and, if so, prepare a QMR for it.

Now, let me turn to our evaluation program. Before final acceptance of a piece of hardware, a new organization, or revised doctrine, we must check it out to insure it fulfills our needs. We have many techniques to use including war gaming, operations research, and

similar methodology. Two of our most important tools are field experiments are troop tests. Let me define these two processes for you.

#### FIELD EXPERIMENTS

A field experiment is a field trial employing specially trained units under controlled conditions. It is oriented towards a specific problem area and is designed to collect objective data for scientific evaluation. A field experiment is problem-oriented, extends over a relatively long period of time, may have several replications which are really mirror-image repetitions, and is characterized by extensive control. It is specifically designed to test organizations and doctrine, not hardware as such.

#### TROOP TESTS

Troop tests, on the other hand, are tests conducted in the field, using TOE units, and are designed to evaluate operational or organizational concepts, doctrine, techniques, procedures, or, sometimes, to gain further information on materiel as it affects concepts, doctrine and/or organizations. Normally these troops tests are conducted in conjunction with tactical field exercises, and, as opposed to field experiments, are unit-oriented, extent over a relatively short period of time, and are characterized by less control.

#### EXPERIMENTATION CENTER

Our *field experimentation program* is conducted by our Experimentation Center at Fort Ord, Calif. The Experimentation Center, with support from the Stanford Research Institute, performs scientific, field evaluations of new concepts, doctrine, and organizations. Their mission is to serve as a field laboratory to evaluate, by objective experimentation and operations, as directed by CDC.

The CDC Experimentation Center is a unique facility in the Free World in that it conducts controlled field experimentation from which scientific data are collected. All aspects of the experiments conducted at the Experimentation Center, commonly called "C-DECK," are accomplished by joint military-scientific effort.

The troop command at "C-DECK" consists of an armored brigade, an umpire-controller group, and supporting elements located at Fort Ord, Camp Roberts, and Hunter-Liggett Military Reservation. The brigade provides all tactical players and conducts the detailed training required for experiments. They are totally committed on this mission and are not available for troop testing or other missions.

The Stanford Research Institute, located at Menlo Park, Calif.,

furnishes scientific support through its Research Office at "C-DECK" headquarters at Fort Ord.

I have tried to show you the overall picture of combat developments, and in particular, the role of the CDC. From this discussion I hope it is apparent to you that we have a job of major proportions. We are constantly trying to improve our structure and procedures. There is certainly room for improvement, but I am convinced that the present system is far superior to the one used previous to the activation of the CDC almost two years ago.

In conclusion then, I would ask you to bear two points in mind. First, future success for the Army will come only if we capitalize upon the very finest weapons and equipment which technology can provide, combined with the very best thinking in the form of doctrine to make these weapons and equipment most effective. Second, we must never forget that in the final analysis, the key to our success is just one man — that lonely individual at the end of the line, the combat soldier on the battlefield.

## PROGRESS OF THE DEFENSE SUPPLY AGENCY

Major General  
**RAY J. LAUX**  
 Assistant Director  
 Plans, Programs and Systems  
 Defense Supply Agency

I am truly grateful for the opportunity to visit the Army Management School and to talk about the Defense Supply Agency. I have heard and know much about the excellence of this School and its accomplishments. The judgments and expressions of the graduates speak most eloquently with respect to the purposes and achievements as well as the quality of the instruction. In my opinion, each one of you is fortunate to be here. Make the most of the opportunity while you have it. For it is to schools such as this that the Defense establishment looks for the quality in individuals to meet the challenges of tomorrow. It is in this arena, the future, that the DSA is destined to play a major role. So let's talk about DSA.

### BACKGROUND

In presenting this subject, I will briefly trace the evolutionary development of integrated management in defense logistics, bring you up-to-date on DSA, and review some of the current trends which are shaping the future logistics structures of the Department of Defense.

They tell a story around the Pentagon about officers assigned to Defense agencies. We are supposed to enter a kind of never-never land in which we wear purple uniforms. Admiral Irwin, who formerly directed the Defense Communications Agency, used to tell of the two brothers who operated a clothing store. One was conservative and the other was a real plunger.

The conservative brother entered the store one day and was shocked to see a bright new purple suit on the rack. He argued with his brother about investing in this kind of merchandise. Finally he walked out, declaring he would remain home until that suit was sold.

Soon after he arrived home, his brother phoned and told him to return because the suit was gone. So he drove down, re-entered the

---

*Major General Laur, graduated from the University of Arizona in 1928, receiving an A.B. in Education. He graduated from the AC&GSC (1942), ICAF (1949), and completed the Advanced Management Program of Harvard University (1956).*

*While attending the University of Arizona, General Laur completed the ROTC program and was commissioned a second lieutenant (Cavalry Reserve) in 1928. He served in the Officer's Reserve in 1928-34 while a high school teacher of science and mathematics.*

store, and found his brother battered and torn, obviously the victim of a beating.

"My goodness," he exclaimed (and you can see that we have very proper storekeepers hereabouts), "did the customer do that to you?"

"No," said his brother, "it was his seeing eye dog."

We of DSA are wary of all dogs, especially sea dogs.

I might say that we have tried to reach as many of the schools as possible during the last two years, not because DSA requires special pleading, but because we consider it vitally important that all of the military, whatever their assignments or career interests, should understand what is happening in logistics.

As you know, the rapid progress of science and technology has profoundly influenced strategy and tactics. Revolutionary developments have occurred, and will continue to occur, in such fields as transportation, communications, and weapons systems. They have opened up new dimensions in space and time which brought unprecedented challenges to the logistician. The multiplicity of new things and their increasing complexity, coupled with the total absence of experience factors in many areas, have created major problems which demand solutions.

I believe it is a fair assessment that the logistics system had not kept pace with the operating forces in adjusting to new concepts, new weapons, and new equipment. But if technology brought massive problems to the supply manager, it also provided management tools that can help in working out solutions. He has at his disposal larger and faster computers, high-speed communications systems, and electronic data-processing equipment with which to perform essential functions more quickly and efficiently than ever before.

Increased attention has been focused in the logistics area by the Department of Defense and the military departments in recent years. New management techniques have been introduced which employ the most modern electronic and mechanical devices. Actually, these management tools and techniques hold out more promises than we have

---

*General Laur entered active service in 1934 as a first lieutenant assigned to the CCC. He served as a staff officer in Arizona and Texas.*

*Recalled to active duty in January 1941, for the next year he served as Deputy Assistant Chief of Staff, G1, Hq., VIII Corps Area, Fort Sam Houston. During World War II he served in executive and planning capacities with the War Department general and special staffs. In February-July 1942 he was Executive Officer of the Assistant Chief of Staff, G1, War Department General Staff.*

*In 1943-46 General Laur was concerned primarily with establishing policies and plans for military government in territory occupied by the U. S. As Executive Officer of the Civil Affairs Division, War Department Special Staff, he served as coordinator between the War Department and other military and civilian agencies of the U. S. and Great Britain, including the Combined Chiefs of Staff.*

*Following his release from active service in January 1946, General Laur joined Trans-World Airlines (Kansas City, Missouri), as executive assistant. He returned to active Army service in December 1946 and served two years as planner for the Civil Affairs Division. He was commissioned in the Regular Army in June 1947.*

resources to explore simultaneously. We in DSA have been obliged to establish priorities of effort and to undertake a time-phased, sequential approach in some areas. Our four customers, the Military Services have similar problems and opportunities and they too are hard at work to improve support.

DSA is, of course, an outstanding example of the trend toward centralization in the management of common supply and related services. You may recall that Secretary of Defense Robert S. McNamara announced his decision to establish this agency 31 August 1961. Twelve days later, while seated under a camouflage net in P'yong-Tek, in the midst of an alert, the message came through announcing the selection of General McNamara as director and ordering him back to the States. He has often said that Korea never looked better or smelled sweeter than it did at that moment.

He reported to Secretary McNamara on 1 October and received clear and explicit instructions. General McNamara was told that DSA would provide effective support in war or peace at the lowest feasible cost. Those are the objectives, stated in proper priority, which govern all of our planning and operations. They also constitute the criteria against which we are judged by Secretary McNamara and the Military Departments. We have made progress towards those objectives as I will explain later.

Soon after DSA was announced, Mr. McNamara was allegedly asked to explain the organization of the Department of Defense. He is said to have replied as follows: "The Department of Defense consists of three Military Departments, the Joint Chiefs of Staff, and the two McNamaras — general and specific."

True or not, it makes a good story.

The similarity in names has caused some confusion. A reporter asked why it is that the Secretary of Defense and the Director of DSA have the same last names. That's a logical question, and General McNamara replied as logically as he could, "because our fathers had the same last names."

---

*Subsequent to his graduation from ICAF in 1947, he filled assignments concerned with budgetary and internal management matters in the Far East Command, the Quartermaster General's Office, QM Market Center System, and the Army and Air Force Exchange System. In the Korean War he was Deputy G4 of the X Corps and later commanded the Kokura General Depot.*

*General Laur was assigned to the Office of the Quartermaster General in Washington in 1952-56, where he was Assistant Quartermaster General for Administration and later Executive Officer to the Quartermaster General. In June 1956 he became Deputy Commander to the QM Market Center System in Chicago, and became Deputy Executive Director when that agency became the Military Subsistence Supply Agency late in 1956. He was named Deputy Chief, Army and Air Force Exchange Service (New York City) in July 1958. He became Chief of the Exchange Service in July 1960.*

*General Laur was assigned to DSA in June 1963.*

*(The present paper was presented at USAMS, Fort Belvoir, Virginia, on 5 February 1964.)*

The reporter printed it!

DSA was established upon a solid base of experience in centralized management within the Military Departments. I refer to the so-called "single manager" system initiated in 1955 and 1956 by the DOD. Under this system, the Secretary of one Military Department became responsible to procure and distribute a specific category of supply for all of the Services.

Thus, Army managed food, clothing and textiles, and general supplies; Navy managed medical and dental items and bulk petroleum. At the same time, assignments were made for common services. Army performed traffic management in CONUS on a Defense-wide basis. Navy managed sealift and Air Force managed airlift.

The original single-manager commodity agencies demonstrated that integrated supply management was sound. They provided effective support. They drew down inventories by more than half a billion dollars in five years' time. They reduced annual operating costs by \$20 million. Encouraged by these results, the DOD made other commodity assignments in 1959 and 1960. By 1961 eight commodities had either been placed under centralized management or were scheduled to come into the system shortly.

However, some problems had developed. Each single manager devised his own systems and procedures and set up his own distribution system, using the Service depots as agents. This was not a major concern when the agencies managed a relatively small number of items. But it could be troublesome in view of the additional assignments comprising more than one million items, including many directly related to weapons systems.

The military customer faced the unpleasant prospect of dealing with eight different supply sources, in addition to his own service, in eight different ways. He might receive centrally managed stocks from any one of 77 depots, some of which handled only one commodity. The Services reasoned that such arrangements could create serious problems in emergency or mobilization.

Secretary McNamara wanted to retain the advantages of the integrated system but he also wanted to eliminate any disadvantages. So he asked the Military Departments and the Joint Staff to consider alternatives designed to improve and strengthen the system. When their study was completed in July 1961, the Secretary consulted with the Military Secretaries and the Chairman of the Joint Chiefs of Staff. Then he decided to establish DSA outside of the Military Departments and reporting directly to him.

He said that he would transfer to DSA the existing commodity and service activities, less MSTs, which remained in Navy, and MATS, which remained in Air Force.

The decision had several beneficial results. As you can see, it immediately shortened the chain of command and drastically reduced decision-making time. Also, it permitted pooling common inventories of many items which had previously been separately managed and stocked. As a consequence, it became possible to draw down long supply in lieu of new procurement. Over the long range, this should permit minimum inventory investment consistent with peacetime operating requirements and realistic mobilization reserve levels.

Perhaps the most significant benefit is that there is, for the first time, a Defense-level, jointly-staffed military organization which can devote its total capabilities to improving logistics support of the services because it has no other mission.

It is important to note that DSA did not spring out of a vacuum. Rather, it evolved from a series of related actions, each of which contributed to restructuring the logistics system on the wholesale level.

In addition to the missions of procurement and distribution of common commodities, the Secretary of Defense assigned several functional programs to DSA on a Department-wide basis. They include traffic management, standardization, coordinated procurement, cataloging, materiel utilization, and surplus property disposal.

We commenced operations on 1 January 1962 after 90 days of preparation. From the outset, we have followed the same basic management concept of decentralized operations. Responsibility and authority were placed in the hands of field commanders to the degree their missions required. We look to them for prompt decisions and results. By relying upon their mature judgment, and their highly competent organizations, we can concentrate the headquarters efforts on overall direction, broad planning, and improved systems and operations.

On the other hand, DSA must and does function as one agency and not a loose federation of semiautonomous activities. We are striving for uniformity in organization, procedures, and practices to the extent that it will increase efficiency and we have come a long way in the last two years.

During the study which preceded the DSA decision, the Services identified several other areas wherein they believed integrated management might be properly extended. They included common chemicals, industrial plant equipment, and aeronautical spare parts. All three were taken under study with participation by the Military Departments.

DSA became responsible 1 July 1963 for supply management of 4,300 chemicals and chemical equipment items related to industrial-type activity. The item assignments were divided between two

existing supply centers: Medical, for apparatus, and Petroleum, for the chemicals.

In the case of industrial plant equipment, DSA recommended improvements through centralized management of that part of the inventory held in reserve and available for current reutilization. This covers some 150,000 items, valued at \$1 billion. We established the Defense Industrial Plant Equipment Center in Memphis, Tenn., to manage this commodity. DIPEC, as we call it, is also establishing central inventory of all such equipment in the DOD. It may later procure general-purpose tooling at the request of a Military Department.

The Aero Materiel Study is a tremendous task and has taken almost two years to complete. We forwarded the study to the Secretary of Defense last month. It covered the management of an inventory in selected classes, related to engines, valued at \$6 billion. It would not be proper to comment upon the findings, since the Services have been asked for comments, but we recognized that Aero materiel is a fast moving, highly technical commodity closely related to weapons systems and therefore gave it our best judgment.

The newest assignment, which became effective 1 November 1963, transferred to DSA from Air Force the operational control of the Defense Documentation Center for Scientific and Technical Information. DDC is located with DSA Headquarters at Cameron Station in Alexandria.

Briefly, the mission involves receipt, storage, and distribution of all formal research reports generated by Defense programs, whether they are prepared by in-house researchers or those working on Defense contracts in universities and industry. To give you some idea of the volume, DDC anticipates receiving more than 50,000 such reports in fiscal 1964.

The problem here is to make known to those qualified to receive this information the results of new research in order to avoid duplication of effort and to apply the new knowledge as quickly as possible.

We also support the Civil Defense Fallout Shelter Program which has thus far involved procurement of some 195 million pounds of survival biscuits and sufficient emergency medical and sanitation kits to provide temporary care for 30 million people.

The sanitation kit is a truly ingenious device. It is packed in a metal tank suitable for the storage of potable water. The idea is that when the water has been consumed, a polyethylene liner can be inserted, a seat installed, and the device then becomes available for its second function as a receptacle for human waste.

General McNamara stated that when the specifications were presented to him, he noted that the tank was 17 inches wide and 21 inches high. After more than 15 years in Washington, he considered himself expert in such matters and recalled that the average height

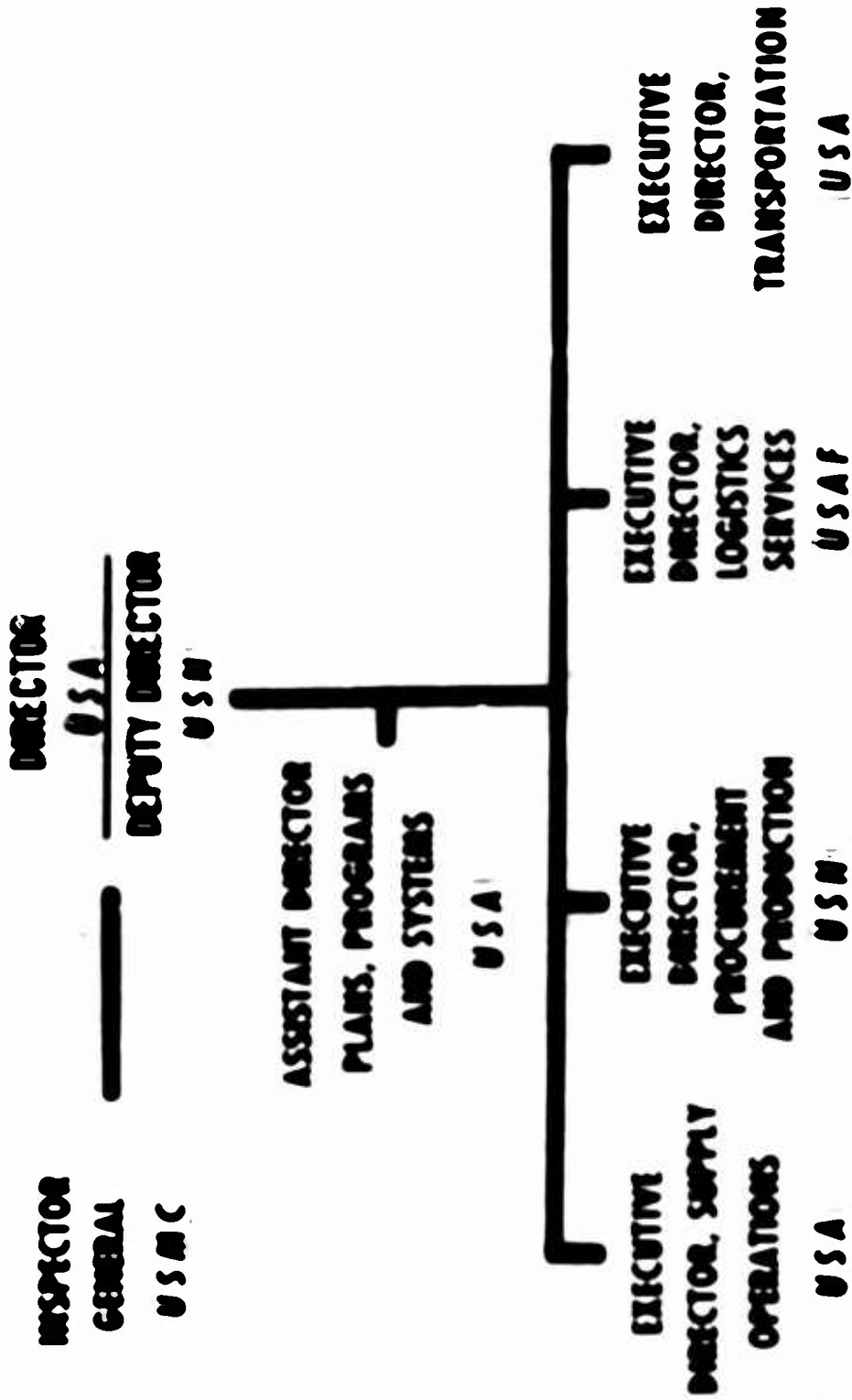

Fig 1 Hq. Defense Supply Agency

of such devices in our homes and offices is 15 to 17 inches. So he innocently asked if they wanted him to issue stirrups. The answer came back, "No!" But you can see things will move at a higher level.

Reflecting that joint staffing policy I mentioned earlier, our headquarters organization is shown in Fig. 1. Note that all of the Services are represented at the directorate or immediately subordinate level.

We are striving to achieve balanced representation: 30% Army, 29% Navy, 26% Air Force, and 6% Marine Corps. Similar proportional representation is being established throughout the DSA field structure.

I might say that, despite the Navy presence, we still have depots in the DSA system. So long as General McNamara is director, they will continue to be known as depots and not "deepots." That a firm, policy decision at the highest level.

DSA is a fair-sized enterprise but considerably smaller than any of the Military Departments.

We will centrally manage more than one million of the 3.9 million items in the Defense supply system this fiscal year. Compare that with one of the nation's largest mail-order houses which stocks 100,000 items.

We will buy about \$3.1 billion in new materiel and sell about \$3.4 billion to the Services and other customers. That includes over \$1 billion in petroleum products not purchased through the Defense Stock Fund.

We employ more than 28,000 people in a coast-to-coast network of commodity management and service centers, depots, procurement, inspection and surplus sales offices. Not one of those personnel spaces represents an addition to the Defense payroll. All were transferred to DSA from the Services and their allocations were reduced proportionately.

We actually performed our tasks with some 3,475 fewer people in fiscal 1963. I expect the personnel "savings," or reductions if you will, to approach the 5,000 mark at the end of fiscal 1964.

Some of those personnel reductions will accrue from the DSA distribution system, which is a network of depots linked electronically with our supply centers where we have centralized stock control.

#### INTEGRATED DEPOT SYSTEM

The design of an integrated depot system was a major undertaking in our first year of operations. There are seven principal depots, each serving an assigned geographical area and carrying a wide range of DSA items. Six of these depots have been transferred

to the operational control of DSA. One, the Atlanta Depot, remains under Army control.

There are four specialized depots, specialized, that is, as to the type commodity stored there or as to the customer served. One in South Philadelphia is co-located with the Clothing and Textile Supply Center. It stocks women's wear, flags, and other specialties. Another, in Dayton, is co-located with the Electronics Supply Center and stocks only electronic parts. Both are operated by DSA.

Norfolk and Oakland, operated by Navy, are the principal sources of DSA material for the fleet, Navy overseas installations, and nearby installations of the other Services. We have also established certain direct supply support points, as Navy requested, at shipyards and maintenance bases which are heavy consumers of certain materials, chiefly industrial hardware. We position DSA stocks at these sites, and much of it moves directly from production source to the point of consumption.

The distribution system will not be fully implemented until fiscal 1965. Meanwhile, we are attriting stocks from 66 other locations and directing new procurement into the main depots. I anticipate that this system will make possible cost reductions of \$11 million annually.

#### RELATIONS WITH SERVICE SUPPLY SYSTEMS

As to our interface with the Service supply systems, I can describe the relationships in this fashion.

The Services determine requirements. They tell us what they want, where and when they want it. DSA computes requirements, decides how much to retain in wholesale inventories, and how much to buy, and accomplishes distribution down to the point at which the material enters the Service-managed retail system.

The Services also determine which items DSA will manage. As new systems or equipment enter the system through the provisioning process, they are carefully scrutinized in a coding procedure. Those which the Services want to retain for management are coded "A." They may decide that DSA can buy them, but we do not become supply manager for these items. Those which are considered susceptible to central management are coded "B" and come to DSA. Those which can be decentralized, or placed on local procurement, are coded "C". Additionally, the Services provide the specifications under which we conduct procurement for them or for centralized inventories.

As a result of coding actions, DSA is the wholesale supplier of parts for many weapons systems, including Polaris, the Army's Hawk air defense missile, and SAC bombers, Minuteman, and other intercontinental ballistic missile systems.

I believe this clearly establishes DSA's role as a vital member of the Defense team.

Turning to those objectives stated by the Secretary of Defense, our primary concern is improved support. The Cuban emergency subjected the DSA system to an unexpected, limited, but nevertheless realistic test in our tenth month. The response was instantaneous and complete. The supply and service centers rapidly absorbed a vastly expanded workload — high-priority requisitions increased by nine times — expedited shipments of materiel, and scheduled the movements for the emergency relocations of forces.

We dispatched liaison officers to CINCLANT, to Army's Logistics Command in Florida, to Fort Bragg and Fort Campbell, and other areas of concentration. Our emergency supply operations center in the headquarters and the field activities worked around the clock, seven days a week, to place the right materiel where it was needed at the right time.

Our customers were well satisfied and the performance elicited commendations from Service commanders.

Since then we have maintained or improved the level of performance throughout the system.

#### COST REDUCTION

As to the second objective, that of cost reduction, we have made significant progress.

DSA's operating costs last year were \$31.3 million less than the Services estimated they would require for the functions we assumed. They will be \$39 million less than the previous base line level this year. Most of this reduction is explained by those personnel savings I mentioned. As examples, we closed one military clothing factory, consolidated 13 inspection and six industrial mobilization offices, and 18 surplus sales offices.

The wholesale supply inventory was drawn down \$261.6 million last fiscal year by selling long stocks to the Services without replenishment and without tapping mobilization reserves. Defense has put some of this to use in the current budget, applying \$123.4 million to Army pay and \$19.3 million to Navy pay. About \$40 million was returned to Navy's Stock Fund. Inventory drawdown is expected to be \$132 million during FY 1964. This illustrates why cost reductions are helpful to our customers and to the DOD.

I much prefer to talk about cost avoidance or cost reduction rather than savings, but whatever term is used, it is not DSA which benefits. It is the customer or the taxpayer.

As to other economies, there has been a sharp reduction in paperwork by eliminating unnecessary reports. This released 100,000 manhours for more productive use.

Space will not permit further discussion of detailed progress, but we are working toward simplifying supply for the user by installing standard procedures. We are meeting assigned goals in the overall DOD cost reduction program in such areas as price competition, item reduction, secondary spare parts buys, value engineering, small business participation, and interservicing.

Up to this point, I have described the background of DSA, its mission, organization, accomplishments, and current status.

As I said earlier, DSA was the product of an evolutionary process. This raises the obvious question whether DSA itself is a step in the further development of an ultimate logistics organization, whatever that might be. So many unknowns and variables are involved that I think the best we can do is to attempt an objective view of certain trends which seem to be shaping the course of Defense logistics and leave it to time to supply a definitive answer.

Several developments have direct bearing upon the organizations of the present and future:

First, and basic, there is the well-known trend towards centralization or consolidation of authority and functions at Defense level. This process began with the establishment of the Office of the Secretary of Defense in 1947 and has continued without interruption. It has been manifested in the enhanced stature of the Joint Chiefs of Staff and the Joint Staff, by the creation of unified commands, and the establishment of the Defense Agencies, such as DCA, DIA, and DSA.

Centralization is by no means confined to Defense-wide activities. The Military Departments have instituted reorganizations in order to clarify and consolidate responsibilities in research and development, and material support. Air Force went through this process several years ago, creating a Systems Command and a Logistics Command. Army eliminated its technical services in favor of a single Materiel Command. Navy is undergoing a comparable realignment focused upon the Office of Naval Materiel.

Next, and obviously related, is the further integration of common functions and services. Transportation was the first to be successfully integrated. Since then, DCA has taken over long-lines communications. Certain facets of intelligence were consolidated under DIA. DSA represents the integration of certain aspects of supply and services. Foreign language instruction is being integrated. DSA was assigned responsibility for the consolidated management of household goods storage and movement a few months ago. Defense has begun a test of centralized contract administration as a possible forerunner to applying this concept to much of the Services' procure-

ment. Printing and publications management is under joint study. How many other areas will be studied is anyone's guess, but the Joint Economic Committee of the Congress identified 40 functions as susceptible to possible integration.

Next, new approaches to weapons systems management have had significant impact upon management systems and practices within the Departments. Defense-level applications of similar concepts in material support are beginning to emerge. The F-4 Program points to the use of single-manager-type support in major weapons systems. The TFX will quite likely follow this pattern. In August 1963 OSD assigned to Army the integrated management of combat and tactical vehicles and parts. These actions suggest the possibility of further consolidations outside of DSA.

From the foregoing, it seems clear that the trend toward Defense-level logistics management will continue and will utilize two basic systems:

One, specialized management organized on a weapon or major equipment system basis to include critical repair parts and supporting equipment.

Two, general support systems organized on commodity or functional basis for a wide range of supply and services in support of the operating forces and weapons systems managers.

This dual pattern has existed within the Services for some time, but its application on centralized basis at Defense level is new. Certainly both types of management are required.

Another relatively new development is the role of the General Services Administration as a major supplier of commercial items to the military. This increasing reliance is reflected in fiscal 1964 estimates of \$976 million in material and services for military use from GSA sources, an increase of \$200 million in one year and 66 percent of total GSA volume.

DOD policy with respect to the utilization of GSA has been clearly stated by Secretary McNamara in these terms: "Whenever we find that it is more economical to use the capabilities or facilities of other Government agencies, with no loss in military effectiveness, and at the same or less cost, we should not and have not hesitated to do so."

In keeping with that policy, and in view of the growing dependence upon GSA, we in DSA have been assigned responsibility to monitor the effectiveness of GSA support to the Services. This is important because the Project 100 Committee and the military logistics chiefs placed great stress upon the military aspects of integration and urged that it must be controlled by military personnel subject to policy guidance of civilian Presidential appointees.

Finally, the advent of electronic and mechanical management tools have made the foregoing changes possible and ushered in a new era in logistics. The impact of automation defies accurate prediction, but it is clear that enormous opportunities are at hand in information technology. As a result, I would anticipate that new management concepts and devices cutting across organizational and functional lines will have even more profound influence upon Defense structures.

To mention only three areas of major interest, the Federal Supply Catalog central files have been automated to the point where rapid and effective screening of catalog information can be accomplished for a wide variety of purposes and users including item entry control and increased utilization of assets. Next, the identification and retrieval of information in Defense research reports will be increasingly automated to improve the service capability of the Defense Documentation Center. Third, the Military Services and DSA are working on Projects leading to a standard technical data system that would be susceptible to automation.

As these efforts go forward, we will have much greater capability to pursue programs for improved procurement, standardization, cataloging, item entry control and inter-servicing. Experience to date has demonstrated that substantial benefits will accrue from the introduction of technological advances.

Now, to conclude, let me turn back to DSA and stress a few fundamentals.

DSA will not provide a magic solution to all supply problems. Many of them lie entirely outside the reach of improvements in organization and method and are rooted in economic constraints, or in technological factors such as design unreliability.

But DSA can and will improve support and reduce costs, as we have done in the first two years of operations. We can move faster if the Services recognize DSA as a full participant. There is still a tendency in some quarters to regard us as "just another supply source" and to equate us with GSA, or to treat the two agencies as if they are interchangeable which they are not.

GSA is entirely civilian. DSA is a jointly-staffed military organization capable of exercising military judgment based upon military training and skills. Yet we have not enjoyed full acceptance as a military organization comparable to the Navy's bureaus, Army's commodity commands, or other wholesale supply agencies within the Departments.

Without such acceptance, the Services may inadvertently pave the way for gradual assumption of logistics functions by a civilian organization which, whatever its performance in time of peace, would become a highly dubious source in the event of mobilization or war.

There is urgent need for solid thinking about the system by which unified commanders obtain support — STRICOM, for example, with its vastly expanded responsibilities. Do we fight as services? Or do we provide forces placed at the disposal of unified commands? And if we do, should not those commands have a general support base attuned to their requirements?

Based upon our performance, I believe that DSA is entitled to your confidence and support and that you should make increasing use of its capabilities. I am confident this will come in due time.

## THE MOBILITY ENVIRONMENT

Major General  
ALDEN K. SIBLEY  
Commanding General  
U. S. Army Mobility Command

Although the Army Management School is perhaps the youngest institution of its kind in the Army, it has in the short space of ten years gained a tremendous reputation in offering an intensive course in the science of management that I am sure each of you will find invaluable to your careers. I consider it a very real privilege and honor to participate in your studies.

More than a decade ago I shared in the conception of the Army Management School, when I served as a member of the Army Policy Council in the Office of Karl Bendetsen, who as you know was at that time Assistant Secretary of the Army for Management. He was deeply concerned about the obvious need for a top-flight Army school of this type, and I therefore had the privilege of assisting him in planning for the Management School and in making this need known in places where it would do the most good. Since establishment of the school in 1954, I know that Karl has had a strong sense of pride and satisfaction over the outstanding success of the Army Management School.

I have been asked to discuss with you the subject of mobility in land warfare and what we are doing in the Mobility Command in Detroit to provide the Army with the mobility equipment it needs for operations in all environments. I should like to ask you, therefore, to join with me in first looking at the various environments in which the Army is asked to fight, and how we manage our mobility resources to assure the success of these operations.

### THE MILITARY ENVIRONMENT

Throughout history the impact of environment upon strategic and tactical mobility has been one of the most important subjects in the whole spectrum of military planning. Environment, when

---

*After his freshman year at the University of Nevada General Sibley was appointed to the U. S. Military Academy, graduating in 1933. He was commissioned in the Corps of Engineers and was selected as a Rhodes scholar, attending Magdalen College, Oxford University, where he took three degrees in theoretical and nuclear physics*

*Returning to the U. S. in 1936, he commanded the 1st Battalion, 5th Engineer*

neglected or poorly evaluated, has frequently led to defeat. Leaders who have neglected this art have invited disaster and have watched their forces in the field, even when superior, brought to their knees. Conversely, the annals of military history are replete with victories won by leaders who understood and mastered the art of the military use of environment.

The military environment, in its broadest sense, encompasses two different but closely related worlds. The first is that composed of physical phenomena, the static and kinetic environmental factors of the earth's surface. The second is what might be called the metaphysical aspects of the military environment, the nonphysical political, economic, sociological, and psychological aspects of the world today.

### *Physical Aspects of Environment*

I should like you to consider with me first the physical aspects of the military environment, and their impact upon strategic and tactical mobility.

We can begin with a hypothetical, featureless world analogous to the watery domain of the navigator.

If the entire earth were as smooth as a billiard ball with no mountains, no valleys, no rivers, no oceans — a smooth waste — what would be the nature of warfare on such an earth? Land warfare would resemble classic sea warfare, and in such an environment we might well examine the teachings of Clausewitz, Douhet, McKinder, and Admiral Mahan, for in an environment without precedent we should have real need for strategic guidance. In the contest between land-going "naval" task forces ranging over the surface, scanning the horizon, speed and maneuver would be crucial, as there would be no place to hide. Land operations would resemble a game of checkers with all moves clearly visible.

If we add the ocean to this hypothetical planet, it is immediately complicated. Different vehicles are required for land and for water.

---

*Regiment, at Fort Belvoir, Virginia, and graduated from the Engineer School in 1937. In 1937-38 he served as a White House aide to President Roosevelt. In the period before the U. S. entered World War II he was Executive Officer during construction of the Conchas Dam in New Mexico, Chief of Construction Inspection of the John Martin Dam in Colorado, and Executive Officer of the St. Lawrence Seaway and Power Project in New York State.*

*In January 1942, General Sibley became Chief Engineer of the U. S. Military North African Mission in Egypt. He later became District Engineer of the North African Engineer District in Cairo. He was subsequently AC of S, G4, and then Deputy Chief of Staff for the Middle East Theater of Operations. Later he assumed command of the Eritrea Base Command (East Africa).*

*In 1943 he served as Chief of the Army Component of the Joint British-U. S. Operations Planning Group, and also commanded the Tripoli Base Command in North Africa. He was ordered to London in late 1943 as Executive Officer to the AC of S, G4, ETO. In early 1944, transferred to SHAEF, London, he helped plan the Normandy invasion. He was later C of S of the SHAEF Mission to France.*

Access to many islands, or even continents, is denied to land vehicles where there are not land bridges. Access to most inland areas is denied to ships because there are no waterways. Our checker game has been complicated. It is as though half the game were played on red squares and half on black, with certain rights of capture or destruction honored across the many boundaries between the red and black. Routes of access or approach become all-important. Areas where many routes coincide, such as an isthmus joining large land masses, or a channel from one large body of water to another, have major military significance. This simple dual environment would encourage feints, backdoor attacks, amphibious redeployments, and flanking assaults. It would be a fast game of mobility and maneuver, with only two kinds of environment, the wet and the dry.

Our oversimplified example, however, excludes the variations in weather and climate all over the earth. Oceans freeze at the poles, and the equatorial areas are hot and humid. Climatic phenomena, temperature, wind and rain, cause great ice sheets in one region and deserts in another. Physical protection requires new procedures, logistics become complex, and the propitious moment for an assault often depends on the sun, the moon, the season of the year, and the ebb and flow of the tides.

The smooth, artificial land of this hypothetical earth must be transformed into what it really is, a complex of mountains and valleys, hills, and plains.

Next, we must include the lakes, rivers, and marshes. To the military obstacles of hills and mountains, we have added many new obstacles that are the consequence of drainage.

Vegetation must be added, including everything from dense forest and jungle to open grassland. We must differentiate the land surface according to the types of soil and roughness of the ground; some soils are dry and firm, others moist and slippery. Finally, we must add the cultural environment: roads, urban areas, and railways. Our analogy to naval warfare now becomes less meaningful. The complexities of

---

*In October 1945, the General was designated a member of the War Department General Staff and returned to the U. S. as Assistant Deputy to the AC of S, G4, in Washington. In 1946 he served as a member of the Joint Logistics Plans Committee of the Joint Chiefs of Staff, and later as Chief of the Army Planning Coordination Group in the Office of the CofS. In 1950 he established the Army Policy Council and served as its first military secretary for 2½ years.*

*In 1952 he went to Paris as Chief of the Logistics Plans Branch, SHAPE. In 1955 he served as Director of the Educational Development Division at the National War College in Washington. He became Division Engineer of the U. S. Army Engineer Division, New England, in 1957, directing the region's largest public works and military construction program.*

*In late 1960, General Sibley was ordered to Saigon as Deputy Chief of the Military Assistance Advisory Group to Vietnam. Late the next year he was appointed Deputy Chief of Engineers for Military Operations, DA, Washington. In June 1962, he was named to head the then newly organized Army Mobility Command.*

*(The present paper was presented at USAMS, Fort Belvoir, Virginia, on 18 February 1964.)*

relief, drainage, vegetation, and other obstructions impose a discipline in which the long way around may be the quickest way to get there. Our original checkerboard analogy no longer holds. Even the game of chess is far simpler than the strategy and tactics of warfare.

The physical character of military environment is governed by both static and kinetic factors, whose interaction generates elements of environment. Static factors include the relief and slope angles of an area; underlying bed rock, soils, the general pattern and characteristics of drainage, and distribution of plants. These so-called static factors are, of course, subject to change, but this change is gradual.

Kinetic factors, on the other hand, change rapidly and at times abruptly. They include rain, wind, temperature, fog, dust, and foliage. Neither static factors nor kinetic factors constitute environment or terrain as such, but they interact in predictable ways with one another to produce what we call the military environment. Impermeable soil plus poor drainage plus rain produce floods, mud, and quagmires that can paralyze mobility. But add another kinetic factor, low temperature, and the outcome can be a frozen plain that permits surface mobility in areas normally impassable. In poorly vegetated areas, aridity plus high winds can loosen dry soil from the surface and produce dust storms. In each case, the kinetic factors do something to the static factors to produce an environmental element. It is characteristic of these elements that they change much more slowly than the kinetic factors which generate them. Thus mud remains long after the rain ceases and dust hangs in the air long after the wind calms.

Examples are legion of the overriding importance of accurate evaluation of environment to gain an advantage both in the offense and in the defense. An attacker with a stronger force seeks mobility and speed to close with the enemy and destroy him. His desire is to secure the element of surprise, reduce opposition rapidly, and move to his objective before the defense has time to rally. To further define this physical environment, let's look at four specific historical examples of military operations in which the environment proved crucial to the outcome.

#### *Desert Campaign, Africa, 1940-42*

Here the attacker is advancing toward us in an environment ideal for rapid cross-country mobility, good observation, and unobstructed fields of fire — an almost ideal environment for offensive operations. I had the privilege of serving for two years with the British Eighth Army in the western desert, and was at first surprised to find that both Alexander and Montgomery had British naval doctrine in their

libraries. Later, when I learned something of desert warfare, their reasons became obvious.

In the North African desert war from 1940 to 1942, when logistics permitted either side to embark on an offensive, the environment was almost entirely in the attacker's favor. Once dislodged from prepared positions, a defending force had virtually nowhere to go except to retreat. The obstacles to mobility were few and far between in the zone of operations; a wide, coastal plain bounded on the south by the great dune-covered expanse of the central desert. An attacker could exploit this type of environment until his momentum was overcome by the sheer magnitude of his logistics problems. On many occasions it was simply a matter of his running out of gas. Historically, the four-year cycles of advance and retreat of the British Eighth Army in the face of Rommel's Afrika Korps were similar to the stretching of a logistic rubber band which snapped the attacker back to his base whenever it became overextended.

#### *Braddock's Campaign, Fort Duquesne, 1755*

The defeat of Braddock in the Battle of Monongahela in 1755 by the French and Indians is a classic example of the effective use of military environment in the defense. Marching in traditional British close order in his move against Fort Duquesne, he was ambushed by the French and Indians within eight miles of his objective. His troops, unfamiliar with the guerrilla tactics of forest warfare, panicked and broke during the battle that followed, and Braddock himself was mortally wounded, defeated not by the superior forces of the French and Indians, but by his enemy's successful exploitation of ideal defense environment.

#### *Hitler's Campaign, Russia, 1941-42*

The defeat of Hitler at the gates of Moscow is an example of poor evaluation of environment in the attack, and of the profound effect this environment had upon the mobility of his Panzer divisions, his most powerful weapon. As in the earlier defeat of Napoleon, owing to a similar miscalculation of the physical environment, Hitler's inability to conquer Russia was also very much the result of his inadequate comprehension of the problems of Russian environment. The success of the German Army against the USSR in the period from June to October 1941 had resulted in large part from environment which permitted his mobile armored divisions to roll eastward. The Germans timed their invasion in June, when they could rely on dry soils after the spring thaws and yet have as much time as possible before winter. They had excellent mobility and drove all the way to

the suburbs of Moscow. The Russians withdrew rapidly, leaving only scorched earth and guerrillas. All was well until the beginning of winter. Without cold-weather clothing and low-temperature lubricants, men and machinery froze. One day's mud became the next day's frozen ground. Assaults were delayed while tanks, frozen in mud, were liberated with crowbars and blow torches. Although logistical problems were critical, Hitler would not tolerate withdrawal to an environment having more favorable defensive characteristics. Artificial strongpoints at the limit of advance were to be held at all cost. The Russians attacked and succeeded. Hitler's refusal to accept the discipline of environment on mobility prevented him from defeating a weaker Russian Army and winning what was almost a sure thing.

*The Malayan Campaign, Singapore, 1941-42*

Finally, the unsuccessful defense of Singapore in the Malayan campaign in World War II is one of the most outstanding historical examples of a tragic misunderstanding of the use of environment in the defense.

Singapore, fortified to command the Straits of Malacca and the southern entrance to the South China Sea, had long been the pivot of British strategy in Southeast Asia. The naval and air base there was intended to secure Australia and the neighboring British and Dutch islands, as well as the entrance to the Indian Ocean from the Pacific. The British assumed that the environment of the dense jungles of Malaya precluded any large-scale overland attack from the north. But the Japanese shrewdly avoided a direct naval assault on Singapore and, under protective air cover, landed 400 miles to the north. They fought down the west side of the Malay Peninsula and used small leap-frogging amphibious operations where necessary to take Singapore from the direction which was supposed to be protected by environment and was therefore left totally undefended.

With these examples in mind, let us look at the earth's three major types of environment, each of which affects profoundly the mobility of military forces. These are 1) the environment of the earth's land masses, 2) the water areas, and 3) the polar regions.

LAND ENVIRONMENT

The land mass of Europe, because of its long history of warfare, furnishes many examples of the dominating influence of environment on military operations. The land environment of Europe, with its hills, mountains, uplands, and plains has for centuries channeled military operations through its many gates, corridors, passes, and strategic waterways.

*Defiles of Europe*

The English Channel has been an obstacle to invasions and counter-invasions since time immemorial. The Skagerrak and Kattegat provide the only entrance to the Baltic. Hitler took Norway in 1940 partly to control the Skagerrak and protect Swedish iron ore shipments to Germany. Control of the land on either side of the water gateway at Gibraltar controls the entrance to the Mediterranean. In all these examples, terrain adjacent to these waterways acquires strategic significance in proportion to the importance of the waterways themselves.

On land, several of the most important gates and corridors in Western Europe are the Toulouse gap, between the Pyrenees and the Central Massif of France, affording passage from the Mediterranean to the French Atlantic coast. The Rhone corridor is a passageway from the French Mediterranean coast to eastern France and southwest Germany. The Belfort gap leads from Eastern France into the Rhine valley. The Lorraine gap connects the Moselle valley of France with the Rhine valley near Strasbourg. The Belgian corridor, between the Ardennes and the coast, will be discussed later in some detail. The Rhine valley itself is a corridor 20 miles wide and 150 miles long leading to the Hessian corridor, which in turn leads to the North German plain.

To the east, the Linz corridor leads into eastern Czechoslovakia and Hungary. The Moravian gateway leads north into the North European plain. In the south, the Ljubljana gap is actually not a corridor but a narrow pass connecting the north coast of the Adriatic with the Hungarian plain. The Morava-Vardar corridor affords access from the Aegean coast to the Hungarian plain, but is winding and partly obstructed.

*Switzerland/Poland*

The permanence of political boundaries has always depended on the environment according to the degree to which this environment impedes or facilitates mobility. Switzerland and Poland furnish clear examples. Switzerland has strong mountain barriers at its perimeter and has been able to continue as an independent state because access is extremely difficult. Relatively easy defense has allowed the Swiss nation to remain serene in the midst of epic struggles between France, Italy, and Germany. Poland, on the other hand, is historically a military pushover in spite of the fortitude of the Polish people, because her borders afford excellent mobility and access on several sides. From the terrain standpoint, these borders are roughly as defensible as those between Kansas and Nebraska. Proof of this is shown by the

routes of invaders from barbarian days through Napoleon's day to the 20th century. Switzerland has survived. Poland has been repeatedly overrun and partitioned.

*German Operations in France, 1914*

In 1914 the Germans achieved surprise and almost captured Paris by violating Belgium's neutrality and moving rapidly through this favorable environment into France. After the first clash in the famous Battle of the Frontiers, the French and the B. E. F. retreated before the advancing Germans until the order for counterattack was given when German forces were within 20 miles of Paris.

*Trench Warfare, 1914-18*

The Germans were stopped and rolled back with the help of the famous taxicab redeployment of the French Sixth Army to the north of Paris, and the easy victory contemplated by Moltke slipped from his grasp. The Germans, lacking sufficient mobility and speed to envelop the French armies and the B. E. F., were forced to retreat to the northeast, where the war stalled into the static slugging matches of the trenches for the next 3½ years. Both sides threw in millions of men and used the defensive characteristics of the environment to the utmost. Later, this same environment, which favored an attack toward the east, was a factor in breaking the Hindenburg line and defeating the Germans.

*German Operations in France, 1940*

In 1940 the Germans again struck rapidly with highly mobile armor through the Ardennes and outflanked the Maginot Line. In 1945 the Allies penetrated Germany back through the same area. In these conflicts the environment ruled out high mobility between these countries except through the Belgian corridor between the Ardennes and the coast. Therefore many major battles have been fought here rather than farther inland to the south, where the environment, with a few exceptions, impedes the attacker and favors defense.

*Plans for Cross-Channel Invasion, 1944*

The selection of Normandy as the site for the massive amphibious assault for our principal invasion of Europe involved a colossal double deception. The German General Staff believed that the invasion, for reasons of economy of effort and good mobility environment, would be along the narrowest part of the English Channel near Calais. Heavy

forces were committed to the defense of this area. Hitler and Rommel, who was in charge of the north coast forces, correctly suspected that the landing would be in Normandy, but felt that it would concentrate on capture of either Cherbourg or Le Havre. Rommel believed that a self-sustaining amphibious landing was beyond the capability of the Allies and that they would require immediately one of these two major ports. He could not be sure which would be the objective and had to prepare to hurdle the Seine in either direction. This uncertainty complicated his initial planning and movement.

#### *Logistic Support of Normandy invasion*

He could scarcely have suspected a real breakthrough in logistics mobility, that the Normandy landings would be logistically supported by the innovation of a floating harbor protected by sunken blockships. As a result, the Allies were able to exploit his weakness in the middle by driving directly inland to secure the beachhead.

#### WATER ENVIRONMENT

Turning to the other side of the world, we see the water environment of the Pacific, in which the islands have great strategic significance.

In World War II the strategy of assaulting only a few key Japanese bases up through the central Pacific, rather than conquering all heavily defended islands along the way, provided the best access to Tokyo. New Guinea, Guadalcanal, and Tarawa initially were strongly attacked to pin down major Japanese forces. The Army, Navy, and Marine team then assaulted selected islands up through the Gilberts, Marshalls, Marianas, and Ryukyus, one by one, developed them as bases, and used them to neutralize resistance in the area by maintaining superiority in the air and on and under the sea. By island-hopping they left behind them, intact but isolated, islands of the Bismarck Archipelago and Rabaul in the Solomons.

As the advance across the Pacific continued along a chain of selected islands, other islands in the Carolines, Marshalls, and northern Marianas were leap-frogged, as well as Wake, Marcus, and small areas in the Philippines.

#### *Victory in the Pacific, 1945*

When the Japanese surrendered in Aug. 1945 a great number of islands, including the Bonin group, were still in Japanese hands. The Japanese were good students of military environment and dug in deeply on most islands, which made conquest of all of these strong

points prohibitive. Moreover, the islands were for the most part so small as to deny opportunities for tactical mobility, and often required direct frontal assault from the moment of attack to the capitulation of defense. Ocean areas between islands provided good maneuvering space for carrier task forces, the seagoing analogue of mobile armored forces on land, by means of which the remaining Japanese bases were effectively neutralized.

Of great significance in the reduction during World War II of the far-flung Japanese empire in the Pacific was the rapid development of amphibious assault techniques and equipment. In this theater also we see the first highly successful use of strategic and tactical air mobility and airborne assault forces.

---

#### THE POLAR ENVIRONMENT

A global gateway now assuming great importance for strategic mobility is the Bering Strait, now that submarine transit of the Arctic Ocean under the pole has been established by the U. S. Navy. Opposite sides of this strait are controlled by today's two strongest powers. In the event of conflict, who will control the strait itself? Whose missile-bearing submarines will be able to use it? Certainly it will be of enormous value to the country which controls it. Moreover, the few miles separating the new State of Alaska from the Soviet Union across the Bering Strait are frozen every year. In February the North Polar ice cap is frozen solid to the USSR, North America, and Greenland. Although all this ice is not land, it can be a useable environment. Thus for a part of each year America has what may be called a strategic environmental connection with the USSR in the direction of closest approach.

#### *Ice-Cap Landing Field*

Technology will soon make access feasible in either direction over the polar area, and the day of protection of the U. S. by large oceans will have passed. Our vulnerability to land attack will be a factor to consider in future strategic planning.

•

The historical examples we have considered point up clearly the incontrovertible fact that he who neglects environment in strategic planning may well be defeated by it. What, then, are we doing as a nation today to profit by these cold, hard lessons of the past? I should like to discuss this question within the framework of what I referred to earlier as the metaphysical environment.

*Metaphysical Aspects of Environment*

Implicit in our historical review of the evaluation of environment for tactical and strategic mobility has been the alternation and interplay between firepower and mobility throughout the history of warfare. Attainment of absolute firepower in the form of the thermonuclear weapon has created a new strategic environment and has changed forever the art of war. The literally world-shattering significance of this thermonuclear bomb, as compared to the uranium fission bomb, is the absence of critical mass. Moreover, there are enough of the proper hydrogen isotopes in ordinary sea water to run the world for the next 10,000 years. Thus you can build as many as you like, as big as you like, almost as cheap as you like — more bank for your buck.

To see how attainment of absolute firepower has affected military strategy, tactics, and organizational concepts, it may be helpful to review the thesis of the interplay between firepower and mobility developed by Gen. Clyde Eddleman, which he published shortly before his retirement as Vice Chief of Staff.

Throughout history the balance between mobility and firepower has been fundamental to the art of warfare. The phenomenal campaigns of Alexander the Great, Caesar, and Genghis Khan were made possible by the comprehension of strategic mobility in an era when firepower was limited in force and range. With the introduction of gunpowder in the latter half of the 13th century, reliance shifted from mobility to firepower, and, in consequence, to defensive tactics. The resulting "age of the fortress," which left Europe dotted with medieval castles, witnessed few such mobile and far-flung expeditions as those of Alexander or Caesar. This was a period of moats and "Maginot Line" thinking. Not until the cavalry campaigns of Frederick the Great and Napoleon was the dominance of mobility again restored.

The advent of the machine gun and long-range artillery, however, brought warfare back to the static and bloody slugging matches of the trenches in World War I. Then the industrial revolution and the technological explosion transformed the art of war into the science of mobility. With military aircraft, fast ships, the battle tank, the armored and transport vehicles, with airborne and amphibious forces, mobility again came into its own in World War II, the only global war of mobility in history. Victory in World War II went inevitably to the possessor of mobile power rather than firepower.

When the Free World emerged victorious from World War II, however, we were faced with two incontrovertible facts: First, the USSR revealed itself as the antithesis of a benign former ally content to live with us in peace. We found instead the spectre of a police

state motivated by Marxist-Leninist Communism, devoted relentlessly to the destruction of the capitalist system and to world conquest by any means. It soon became clear to us that continued adherence by the masters of the Kremlin to Marxist-Leninist doctrine of world conquest was confirmed almost daily in their every word and deed.

The second unequivocal fact that faced the U. S. was the consequence of a technological revolution which we ourselves had precipitated. We were faced with a radical transition in weapons which we came to realize was without precedent in the history of mankind.

Our national strategic concept was founded on the assumption that the American democracy would not initiate aggressive acts, with the corollary that the military advantage inherent in a surprise attack had to be conceded to the aggressor. As a counter to surprise attack, therefore, the capacity for massive retaliation gained currency as the only effective deterrent, and almost every ounce of fissionable material was allocated to a double brassed-rim wallop at the Soviet ball-bearing industry. The inherent limitation of this concept was that little less than a direct threat to the survival of the U. S. itself would have caused us to release such a holocaust. The masters of the Kremlin of course knew this. They also know that because of a horror of nuclear war gripping the minds of our allies, we were not likely to use such ultimate measure to counter limited peripheral aggressions. The doctrine of massive retaliation, and the absence of a capability for limited employment of nuclear force which might have carried with it the conviction of plausibility, may give some clue to the predilection of Communism for conquest through subversion, sabotage, political deceit, guerrilla activity, and infiltration around the periphery of their world island.

The record of the states enslaved by international Communism, however, was clear: initially Russia, then Estonia, Latvia, Lithuania, Czechoslovakia, Poland, Bulgaria, Hungary, Rumania, Albania, East Germany, mainland China, Outer Mongolia, Tibet, North Korea, North Vietnam, and in our own hemisphere, Cuba. Sixteen nations or parts of nations — over 900 millions of people have thus been enslaved by the Communist brand of aggression.

### *An Hypothesis*

In the face of this stealthy encroachment of Communism we at last fully recognized the nature of the threat. Only in the last few years have we come to recognize the real war being fought against us. The advent of nuclear energy, the attainment of absolute firepower, has changed forever the art of war. Hence I should like to pose an hypothesis which I believe to be original. It is, of course, controversial,

but the very fact of our attainment of absolute firepower has affected profoundly our national strategic concept and the Army organization required to implement this strategy. My hypothesis is this: If we as a civilization are to have a history, this must be the last era in the history of mankind of the ascendancy of firepower. Although maintenance of our capability for massive nuclear retaliation, as well as employment of tactical nuclear weapons, remains essential for deterring all-out nuclear war, we must be prepared for the actual war that is being fought against us — the nibbling, limited, guerrilla and conventional war of Communist aggression. Therefore it is evident that today, in 1964, we have arrived at the dawn of the golden age of strategic and tactical mobility in the art of war. This will be the underlying philosophy of the art of war in the future. We can never go back to a strategy based on firepower. We must build our capabilities now for quick, lightning-like thrusts to put out brush-fire wars, to enable the modern Army to respond even more rapidly to a wide variety of conflict situations, from subversion and insurgency to major military operations.

If this hypothesis is valid, we must, as never before, attack head on the tough problems of mobility in land warfare. We cannot confine ourselves to just planning for the future. We must act now to develop and acquire the mobility equipment needed to face the military challenge of today in the environments of land, water, and air. We are faced today with this immediate problem in South Vietnam, where the environment is the determining factor in almost all military operations.

With the rapid growth in recent years of our capability to move men and equipment by air over environmental obstacles, particularly by use of the helicopter, and to actually exploit environment to our benefit in air operations, a whole new and revolutionary vista of land warfare mobility has opened before us.

Three years ago, when I served as Deputy Chief of MAAG in Vietnam, I learned first hand of the tremendous advantages of Army tactical air mobility in that country's valiant struggle against take-over by Viet Cong Communist forces. Air mobility answered the previously impossible problems posed by Vietnam's swamps, rice-paddies, and impenetrable jungles in remote mountain areas. To give the Vietnamese this capability, I flew half way around the world with Vietnam Defense Secretary Thuan to consult with President Kennedy in Washington and present to him our reasons for immediate and rapid build-up of air mobility in the form of the CH-34. Eleven of these helicopters were sent, and they were first used in an operation against Viet Cong infiltration down the Ho Chi-Minh trail and across the border into Vietnam. To close this border, it became necessary to establish a battalion-strength border post in dense mountain jungle

miles from the nearest road. A three-day march through guerrilla-infiltrated rain forest had levied such heavy casualties on infantry patrols that surface penetration had to be abandoned.

The job was given to the host country's army engineer who, supported by their American Engineer counterparts, took apart four D-4 bulldozers, lifted the parts 40 miles by CH-34 helicopter, which then served as a crane for reassembly at the site.

A typical "Beau Geste" fort with mud walls and pointed bamboo barricades held off the guerrillas until a landing strip could be cleared in the jungle and engineer and combat units could be ferried in to complete a PSP field for heavier cargo aircraft.

~~The interior of the fort had the typical construction of bamboo barricades and huts to which the troops returned each evening.~~

•

The Army's need for true strategic and tactical mobility, in all conceivable types of environment, must be met by the best possible efforts of the military-industry team. Our scientific study of air mobility, land locomotion, soils, soft-ground and off-road mobility, must be pursued with all the resources at our command. Environmental factors, which have for centuries dictated military strategy and tactics, must be overcome by science and technology. Newly developed equipment — air, ground, and amphibious — including ground-effects machines (GEMS), the para-glider, the aerial jeep, as well as newly developed articulated off-road vehicles, must be developed and evaluated in the severest of field tests.

Attainment of greater air mobility for the Army has been under intensive study at Fort Benning, Georgia. The 11th Air Assault Division, organized in February of this year under General Harry Kinnard, is now testing the organization and capabilities of a completely air-mobile division recommended by the Howze Board. The Mobility Command is fully supporting this pioneering test, which daily brings to light requirements for new mobility equipment and vehicles not presently found in the Army inventory.

Never before in our history has the military-industry complex of the U. S. faced a greater challenge. The Cold War is truly a war of science, brainpower, technology and industrial power. We are partners in a scientific and technological struggle that may well shape man's destiny here on earth for centuries to come. We are challenged by a monolithic Communist dictatorship dedicated to the subjugation of the Free World by any means; and, in the present confrontation with international Communism, we must, together, through our system of free enterprise, continue to surpass the scientific and industrial

achievement of the Communist bloc nations. To meet this challenge, the Army and industry together must continue to exploit, with all strength and imagination, every new scientific and technological advance in the field of mobility. Through this close Army-industry partnership, I am confident that the U. S., by fielding the most versatile and mobile Army in the world, will meet with success any threat to the security and survival of the Free World.

## CONTROL OF A MAJOR ENTERPRISE

Major General  
WILLIAM B. BUNKER  
Comptroller and Director of Programs  
U. S. Army Materiel Command

The subject of control was one of the first matters to which we in the planning group addressed ourselves in the early, prenatal days of AMC (Army Materiel Command). While we found the voluminous studies of the Army reorganization had much to say on alleged difficulties of the Technical Service System, incompatibilities between the Army's organization and DOD requirements, and many other matters, this vital area was left largely void. Indeed, in spite of the importance of command and control to all military organizations, there is little evidence that the Army has given this important matter any real serious consideration since its first significant reorganization by Secretary Upton some 45 years ago. This matter has been one of considerable interest to me over the past ten years or so and is certainly a continuing problem in my present assignment.

The importance of this subject is emphasized by the fact that one of General Wheeler's first actions on becoming our Chief of Staff was to launch an extensive investigation into the reported "overcontrol and overmanagement" reported to him by commanders in the field. The reactions of the queried senior managers were enthusiastic and listed numerous examples where commanders felt that their flexibility and command prerogatives were infringed. On the basis of these studies, the Chief of Staff has launched an intensive program under the Comptroller of the Army to find ways in which the burdens complained of could be reduced.

In this discussion I do not propose to solve General Hackett's problem or to give you a blueprint for control. Since the problem is a continuing one, however, I thought it might be interesting to explore it.

### Control — What Is It?

Discussions on the subject of control start with an inhibition, as Dean Jerome points out in his recent book on the subject.\* Under

\*Jerome, W. T., III, *Executive Control - The Catalyst*, New York: John Wiley & Sons, Inc., 1961.

*General Bunker entered the U. S. Military Academy, and was graduated and commissioned in the Cavalry in 1914. In 1936 he transferred to the Engineers and attended MIT, where he was awarded the degree of M.S. in Engineering. In the*

the theories of decentralized management and the so-called "X theory" of MacGregor which we all preach, if seldom practice, "control" is a nasty word. Indeed, right after World War II, even the Army through a brief period of "happy family" management of its military units as a delayed reaction to Mauldin and the *Stars and Stripes* "B Bag."

It is well, therefore, to get some sort of handle on what this particular discussion is all about. Are we talking about the ability of a commander to exercise his prerogative? The ability of a higher echelon to correct the mistakes of the lower ones? The exercise of discipline for the general good? Or, the right of each superior to be fully informed of what is happening in the nether reaches of his organization?

Actually, control is, of course, none, some, or *all* of these things, depending on who is doing the controlling. Like many of the areas of management and the other social sciences, it is a quite personal thing and, while it may be subject to certain tested principles and measures, it is fundamentally related to the individual philosophy of management of the responsible individual. An unfortunate consequence of this fact is that each new management team tends to install new controls of its purposes, but seldom removes those of its predecessors.

The implication of control, as I will discuss later, depends upon whether one is the director or recipient. Controls exercised over us are always despotic; those which *we* exercise, benign.

For the purposes of this discussion, I have invented my own admittedly narrow definition as follows:

"Control is the way in which a manager assures himself that the portion of his work which he has given to another is being pursued to his satisfaction."

---

*period 1939-42 he was stationed in Nicaragua in charge of a barge canal survey, and as engineering and mathematics instructor at the Nicaragua Military Academy.*

*During World War II he was Deputy in charge of the Transportation Corps supply program. In 1945 he was assigned as Transportation Officer of the 7th U. S. Army in Germany.*

*In 1948, during the Berlin Airlift, General Bunker was placed in charge of gathering shipments and loading aircraft in the U. S. Zone and unloading and distributing cargo in Berlin. He organized a similar system between Korea and Japan with the breakout of hostilities in 1950.*

*In late 1950 General Bunker was assigned as Chief of the Air Transport Division, with the responsibility of investigating the application of the helicopter to Army transportation. This investigation resulted in an immediate and large-scale expansion of this activity.*

*In 1954 he was assigned as the Commandant of the U. S. Army Transportation School, Fort Eustis, Virginia. In 1955 he was assigned as Commander of the U. S. Army Transportation Materiel Command, St. Louis, Missouri. He was promoted to major general in June 1961.*

*In February 1962, he was assigned to a task force under Lieutenant General Besson to develop the organization and concept of operations for the Army's new Materiel Command. In June that year he was assigned as its Comptroller and Director of Programs.*

*(The present paper was prepared from the transcription of an oral presentation given at Fort Belvoir, Virginia, on 10 December 1963.)*

Note that I have kept this definition general and subjective in order that our discussion can be as uninhibited and broad as possible. Under it, we can consider control to cover the extremes of a teacher standing at his pupil's side and supervising each step of a problem in mathematics to a complete reliance on confidence and trust which a man might demonstrate in letting his brother manage a piece of property for him. In other words, the whole gamut of human relationship from "x" to "y"!

You can also note that some of the elements of control to which we as individuals are subject — police regulations for the general welfare, political restraints for the good of the country, moral inhibition for the good of civilization, to name some — are omitted.

Also, I have placed this definition in a management, rather than in a military sense, since, at least in the part of the Army in which I am involved, nonmilitary controls are the most conspicuous.

Before starting the exploration of this subject, we should recognize another factor that is involved. This is the question of scalar or hierarchial rights. In any discussion on this subject, particularly when it revolves around a specific control or a specific action, a considerable portion of the usual negative reaction is generated by a feeling that the higher echelons are transgressing the authority of the subordinate and that they have no such rights. You know, the "Mother, I'd rather do it myself" reaction.

Of course, we all recognize that the controls exercised by those above us are meddlesome, unduly expensive, and unnecessary, while those which we place on our subordinates are the minimum required for us to ensure that our responsibilities are being properly executed.

A proper evaluation of the subject will require the difficult feat of both recognizing top management's right to know and respecting lower management's right to make its own mistakes. At least for the period of this discussion, therefore, we will assume that a manager is perfectly justified in exercising as much control as he wishes. We will try to avoid the inherent reactions of all of us that, in this area, optimum and minimum are synonymous.

The cogency of this subject today comes from the rapidly increasing trend towards centralization of authority and the proliferation of controls at higher and higher echelons of management. This is not a veiled objection to the action of the current Secretary of Defense in reserving weapons selection decisions to his office. The rapid increase of centralization as a theory of operations is equally evident in all areas of management, both civil and governmental, and certainly all businesses are complaining of the billowing tides of paper in which they are becoming engulfed.

This is a phenomenon which is apparent in businesses of all sizes throughout the country. If you look at the reorganization of

businesses large and small, you will find that there is an increasing trend toward centralization of management. The rapid increase is both welcomed and complained about. It is welcomed because of the control it gives top management; it is complained about because of the amount of paper work that it is engendering.

The twin rollers of communications and data processing, as they have gained in capacity over the past few years, are resulting — designedly or not — in decreasing substantially the latitude within which a subordinate is left to his own judgment. While our management texts still teach delegation of authority and decentralization as a way of life, in actuality the trend is being reversed at an accelerating rate. Maybe we only rationalized our desire for decentralization, and now that technology makes it no longer necessary, we can go back to the inherent advantages of one-man management. Maybe today's events are so important and so fastpaced that we cannot keep our subordinates well enough advised for a decentralized system. Whatever the reason, there is no question but that these forces of communications and data processing — or, if you will, automation of the management process — are leading to the "de-skilling of middle management" as Dr. Adrian McDonough calls it.

After that rather lengthy introduction, I think we are ready to get down to the specifics of control as we see it in today's Army.

### **Some of Today's Controls**

First, I think it would be well to review the various controls to which a typical military unit or activity is subjected in today's environment. It is frequently said that if a problem is explored carefully enough, its solution will become apparent. It is also a philosophy of mine that we must carefully distinguish between problems which are, in fact, susceptible of solution and situations which, however unpleasant, can only be endured.

I am not sure, in other words, that the following will help us solve our problems, but it may help us put up with our fate.

### **Congressional Control**

Of course, the primary — at least in the historical sense — control over the Army is that exercised by the Legislative Branch of the Government as prescribed by the Constitution. While the Congress can, and does, pass many special laws to control specific acts of the Army, its principal control lies in the power of the purse.

By determining not only the total size of the various Army appropriations, but also the amounts which can be spent on certain

individual weapons systems, or functions, and even specified installations, the Congress does impose many detailed controls over the Army.

The Military Affairs Committee of the Congress exercises other specific controls which vary in intensity from the (usually) rather routine confirmation of appointments to specific authorization for percentages of officers in certain grades, numbers of aircraft, ships, missiles, divisions, etc.

While the main channels of Congressional control do, in fact, follow our command and control structure, they often reach into the most detailed areas of individual action, such as the \$25,000 limitation on repairs and modifications, specific contract awards, and employment practices at specific localities.

The more difficult of Congressional controls lie in procurement areas which require us to give special attention to specific areas such as small business and labor surplus areas, competitive procurement, and the like.

An interesting facet of Congressional control is the fact that it has engendered no particularly cumbersome reporting and control system. While we carry several hundreds of tons of paper to Congress each year to defend our budgets and keep a fair number of people busy answering Congressional correspondence, no regular reporting and control information system has been constructed to allow Congress to interject itself into the day-to-day operations of the executive branches.

In discussing the control networks of the Army, we must first, of course, recognize, though it has less than overriding significance in today's situation, our military command structure.

Even here, we have really two systems, the command (and control) prerogatives of the rank enjoyed by the individual and the organizational scalar hierarchy within which one is working.

We have the hierarchy of rank in which colonels outrank lieutenants regardless of their location in the system and have a certain inherent control over the activities of those who are subordinate merely by, if you will, seniority. Then we of course have the military unit control from Army unit to division down to the private. On top of this we have our basic ZI control system running from the Department of the Army for example, to CONARC, the armies, and posts, camps, and stations.

While, under the concept of Army Command Management, the main part of the Army's business is conducted in this complex, I think most of us will agree that, in fact, this is one of the weakest or least used of our control structures. While all of our regulations carry command lines and the AG busies himself signing letters for the Chief of Staff, our day-to-day business and decisions more frequently travel some of the other nets we will discuss later.

Some of the reasons why this is so will, I think, become apparent as this discussion progresses; suffice it for the moment to point out that we seldom have meetings between commanders and their subordinates and certainly — probably correctly — regard with horror the attempts of our generals to conduct business directly with each other. A senior officer, when he was a young colonel in an Army staff section before World War II, is credited with the sage remark that general officers should be restricted to saying "Good morning, General" to each other.

Let us bear in mind one phenomenon: once a year the Chief of Staff has a commander's meeting with his subordinate commanders. Many of the subordinate commanders never have command meetings. This would be tantamount to a company having one meeting of its board of directors per year. Obviously that would not be the manner in which their day-to-day business is conducted. As you may already know, the executive committee — in effect, the internal board of directors — of Du Pont meet every single day just to run those companies. This is one of the symptoms relating to my statement that the day-to-day business of the Army does not in fact follow the central line of the Army Command Management structure.

The main reason I say that the Army's business is not controlled through the command network lies in the "Army Management Structure and the performance budget." This is the primary control net used by the Army over its operations. It, basically, is a combined program and fiscal control system following the cost accounting break-out of our Operative and Maintenance Structure.

While the hierarchy of the Army's Command Structure is recognized in the preparation of budget estimates, cost and performance evaluation, and other steps in the process of budgeting, funding, and analyzing the Army's O&MA business; the "performance" budgeting installed in 1950 has basically placed the major control emphasis across functional lines. Each of these functional areas is represented in the staff layers up the channel of command and results in the establishment of parochial "stovepipe" domains which cut cleanly across command lines.

Basically, the performance budget, as interpreted in the Department of the Army — it is slightly different in the Air Force and the Navy — places primary emphasis on performance factors which are system- or process-oriented. We have the performance of maintenance, of procurement, of standardization, of training, and these cut straightway across the command channel. In other words, if the command channel or the Army management system really followed this, you would not have the breaking out of the maintenance function between maintenance people who are assembling, evaluating, and

deciding on a day-to-day, or hour-to-hour if you will, basis the operation of the maintenance function.

As each program director develops "his" budget through legislative and negotiation give and take at his command layer, he develops certain direct interests in its future accomplishment. As a result, specific controls within each of these functional areas are applied at each review level which remove the commander's latitude to move his effort up or down the performance ladder and yet give to the performance manager the ability to change emphasis between commands. In other words, if we use the principle of activity or program directors at the Army Staff, major command and major subordinate command level -- as we do -- then we will obviously have more traffic in control and management between these individuals than between the commanders.

Perhaps this phenomenon is most clearly demonstrated in the R&D area where the control and decision system follows a specialized reporting and control system which normally bypasses commanders at each level of command, except as the various staff officers involved feel inclined to bring their commanders into the discussion.

Here we have a hierarchy that reaches from the lowest laboratory bench all the way up to, in effect, an Assistant Secretary of Defense. These decisions are made tightly and individually within the R&D structure and function and indeed carry a separate appropriation from Congress. And there is no way in which even the Chief of Staff of the Army, for example, could decide that, rather than spend money to place more development effort on the Nike Zeus, he would rather buy another 2,000 M-60 tanks. This does not lie within the command prerogative. If he took the money off the Zeus, the R&D project manager, the Secretary of Defense, the CDR&E, would immediately take that money and place it in some other R&D activity, and probably not within the Army structure.

Quite frequently these activity directors do not feel it necessary to consult with or to coordinate their day-to-day decisions within their own command level. Not only not with their commanders but not with their colleagues in the other staff sections in which they happen to be co-located.

As our performance budget structure gets broken into finer and finer subdivisions and each is subject to review at higher and higher levels, it is obvious that the commander becomes merely a custodian of responsibilities and decisions made above him and, hence, subject to their control.

The traditional method of controlling military organizations has been inspections. This field, once primarily the area of our own Inspectors General, has been broadened in both scope and depth and become the pastime of numerous agencies.

The average installation or activity is now subject to rather constant surveillance across the whole spectrum of its activities by inspectors from the Army Audit Agency, the General Accounting Office, the Civil Service Commission, and Inspector General. Many of our major activities have fair-sized staffs of these activities in permanent residence; some programs, like the Army's tank program, have their own permanent chaperone.

If you do not think they control, take, for example, the announcement that the General Accounting Office has directed the three military Services to adopt the "nude engine" concept. This means that when you requisition a new or replacement aircraft engine, you get the engine; you have to install on it the carburetor or fuel controls and everything else that makes it into an engine that you can install in an aircraft. Some of our engines in all Services were denuded to limited or maximum extent, depending on the relative value of the accessories, their relative life, and a lot of other things. This control, this decision, and the control, therefore, over the activities not only of the Army, but also the Navy, Air Force, and Coast Guard, were implemented and controlled through General Accounting Office channels.

We have even some of our programs under constant and resident surveillance. A typical one is the Army tank program as an object of a permanent General Accounting Office and Army Audit Agency resident inspection team.

Each of these inspecting activities has at the same time broadened the scope of its activities to cover the whole area of activity. Thus the General Accounting Office can comment on the acceptability of the M-48 tank, the Army Audit Agency on the internal organization of a supply activity, or the Personnel Inspection Team on the paperwork procedures of the command.

Every commander today is spending a major portion of his time evaluating, answering, and following up on the results of inspections. The volume of this business is tending to place more and more of it into the hands of functional specialists and the accelerated time schedule under which we are processing them seldom leaves commanders time enough to give them the amount of personal attention they warrant.

On the other hand, the fact that a program, such as secondary item supply management, is subject to periodic inspection and surveillance is never taken as justification for removal of any of the other controls to which it is subject.

In spite of its relevance as a performance factor, "numbers of people involved" is not generally a control factor in civilian industry, except incidentally through the budgetary or profit analysis process. We in the Government, and in the military in particular, have

established a personnel accounting system for our manpower resources which is parallel to our basic command system and generally does not cross these lines. Periodically, however, efforts are made to place people accounting in the same functional stratification as the operating budget.

There is increasing emphasis on placing personnel management in the performance structure or process channel which reaches across command lines.

In the original preparation of our FY 64 program, the Deputy Chief of Staff for Personnel gave to each command specific allocation of personnel by Budget Activity Account and stated that they could not be interchanged within commands, except with his prior approval. While this restriction has since been eliminated, we are still required to maintain our personnel records in this fashion and to report all changes as they occur. Thus a command decision to emphasize maintenance at the expense of training is subject to dual functional controls of both program (and funds) and personnel.

It has been my experience that once you start accounting in any particular format you will immediately be subjected to controls in exactly this same format. Thus, for example, a commander's decision to de-emphasize maintenance at the expense of increasing his training function or to de-emphasize his training function and increase his maintenance under the concept of Project ARM, while inhibited already on the financial side from program controls, is separately inhibited on the personnel side from personnel controls.

Certain rather arbitrary controls, not necessarily compatible with command or functional responsibilities, are found in the personnel allocation system, however, such as:

1. Arbitrary percentages or other limitations on military personnel in logistic offices.
2. Generalized attack on "grade creep" without recognition of effects of automation, contracting-out, reduced maintenance levels, and other factors.
3. Arbitrarily assigned "productivity gains" as personnel reductions.

Interestingly, this year we got our subject issue from the Secretary of Defense which assigned a 1 1/2 percent reduction in civilian personnel in the Army after all other management reductions have been made. Another 1 1/2 percent reduction for so-called increased productivity. Obviously we are entering a reclamation to state that the productivity increase was already cranked into the management decisions which had been submitted. I am not sanguine on the results of this rebuttal.

While most of these comments apply to our logistic operation a similar phenomenon is present in our military organization. Arbitrary

restrictions on numbers of overhead, administrative and logistics people in units, from battalion to theater force commanders to divert line troops to service functions to meet their minimum requirements. Our combat units invariably take the field with significant strength reductions in order to meet their logistic needs — yet we always claim to be reducing the excess fat from our organization.

### Command Channel Stock Fund

There is a new control system now being imposed on the Army which I think you should take a look at. This has not been announced as a control system, as a matter of fact, it was announced as a way to get rid of controls. It is called the Command Channel or Horizontal Stock Fund. But in the context of our discussion I would like to submit that this is an arbitrary top-management control over every installation in the Army. Major commanders will now be required to submit a separate budget for materials by commodities, not by function, not by performance or the use to which these commodities are to be placed. This being the case, they cannot help but be merely a reflection of one of their assets, either the amount of materials that they have on hand, the amount they expect to use, the amount they need for replacement. In other words, it is a device to control the inventory as a separate operation at each post, camp, and station.

Thus one of the newer control systems being installed throughout the Army is the Command Channel or Horizontal Stock Fund. While the announced purport of this system is to allow posts, camps, and stations to finance their local inventories without obligation of their O&MA funds, I feel that it must be listed as a control device. Since the major commanders are required to submit their budgets and reports on a commodity basis and they are so accumulated at DA level, this control is obviously not directly related to the performance areas used in the Budget and Programming System.

Although under the accrual system of accounting under which we have operated for many years, O&MA financial inventories were considered as assets to be expended in program performance, this control was never overly effective. It is obvious that by review of the FIA and Acquisition Budgets under the Command Channel Stock Fund System that the Army Staff will have a forceful tool to control inventory acquisition and drawdown at all installations. In distinction to the three reports per year submitted under our prior cost and performance reporting system, we will now be required to furnish these data on a monthly basis.

It is not a "Command Channel Stock Fund," obviously, because it is segregated by commodities and summed by commodities. It therefore is more properly termed a "Horizontal Stock Fund."

If an operation requires the three Ms of assets — men, money, and materiel — we have now perfected a system whereby the commander is required to get them from three independent sources!

The manpower is controlled through personnel channels; the money is controlled through financial and activity channels; the materiel is controlled through the Horizontal Stock Fund. Now, instead of getting, as before, your resources to perform your job through two different channels, you have a separate source for each one of your Ms. At least this makes your difficulty a little easier to understand, if not easier to cope with.

### **Special Program Controls**

There are a great many special program controls. The ones which I have discussed so far generally reach across the whole spectrum of your responsibility. But we have a tremendous number of so-called program controls that reach in and grab a specific item. One of the reasons for this of course is that the DOD is such a tremendous organization that if you take anything, the money spent this year on shoe laces, for example, and you add it all together, you get a horrendous amount of money.

Admittedly this is somewhat out of context, but by taking almost anything as a separate entity, across the three Services you get such a tremendous figure in absolute terms that it cries for its own special control and special management. For example, Army Aviation, except at Fort Rucker, which is the center and school, accounts for 3, 4, or 5 percent of the installation's total activity; but when the whole thing is summed together in the Army, it is a billion-dollar program. And a billion-dollar program should not be left alone; it has got to be managed.

As a matter of fact, if you will look at the recent change to the Army management structure, you will find that whereas we have followed the program package breakdown for the operating forces, we have a memo entry to separately segregate out the cost of operating each individual aircraft worldwide by type and model. This is a tremendously expensive reporting and control system, as shown by the fact that it is a large sum when summed together, even though it may be included in figures controlled by one of the systems discussed earlier.

Another typical one which affects all of the Defense establishment is the control of automatic data-processing equipment. ADP equipment is a means to an end; it is a way of getting your work done. Without it you could not get your work done. We are complete captives; if we did not have a ADPS, the Pentagon would never find

you, and you would be like that general in the funny papers. You would not get paid. Nothing would happen. We are complete captives to it, but it obviously pays its way. As a matter of fact, the Defense establishment as a whole has led the way in the industrial and business use of ADPS. But we control it as if it were a crime. It takes roughly 1½ to 2 years to get approval to get a piece of automatic data-processing equipment because it is a centrally controlled program. There has been in recent months a certain relaxation in delegation of this, but it is infinitesimal. It is a separately controlled program.

Project ARM — what is its objective? To control the readiness of units with a computer in the Pentagon. Was it not already the responsibility of somebody down the ACMS channel, without separating out the state of readiness of the 30 or 40 items that are centrally managed in the Pentagon? In other words, it is a duplicating cross control system.

Cost reduction probably is not properly listed as a control mechanism, but it is a fact that every activity installation and almost every individual in the Military Services has been assigned a specific cost-reduction goal. There is an elaborate reporting system that controls this cost-reduction program up to the Secretary of Defense. I personally think it is worthwhile; I think it has paid dividends, but it is obviously a duplicating control device that conflicts with the others which I have already mentioned.

A few months back the Assistant Secretary of Defense (I&L) appointed a Deputy Assistant Secretary of Defense for Maintenance. The maintenance function of course is scattered in the Military Services as far as responsibility in reporting is concerned. In order for him to function as a chief of maintenance as a process throughout the Army, Navy, and Air Force, we are having to establish a control and reporting device that controls maintenance as the objective all the way up through the entire military hierarchy.

Thus, in addition to the controls so far enumerated, we are subjected to many special controls designed to cover specific segments or characteristics of our operation. General controls cover the entire spectrum of our operation and, if the performance budget is properly designed, should be adequate. On the other hand, the Army is such a large organization that almost any relatively small operation becomes a significant amount of money when extracted across the entire spectrum. Thus a special control on aviation is fruitful as a billion-dollar program, although any specific commander may find it less than three or four percent of his total responsibility.

Some of these special controls have generated elaborate reporting, approval, and control systems -- the acquisition and use of ADPE, for example. The recent change to our cost and performance

reporting system requires detailed reporting by aircraft type of all operating and maintenance expense worldwide.

Project ARM is a control procedure designed to allow the DA general staff to supervise the combat readiness of the units of the Army. It replaces the commander's responsibility for evaluating his own effectiveness with a numeric rating system which allows the Pentagon computers to draw task force elements out of its files and determine their readiness for any contingency planning.

Cost reduction is probably not properly listed as a control mechanism. Each commander has, however, been assigned specific objectives in an array of areas and is required to report his progress — subject to Army Audit Agency approval — to the Secretary of Defense.

When AMC was first established to take over the decapitated technical services, one of our problems was to get some degrees of control over what was happening. Since obviously the vast majority of the work would continue for a considerable length of time by exactly the same people who had been doing it before, and since we, particularly General Besson, had no way of really getting hold of this, he accepted and expanded the theory of project manager as a control device.

### **The Project Manager**

A rather recent control device of the DOD has been the project manager. Considered as a "special task force," it represents no really new principle, but the degree to which it is employed and the special limitation now being required in the use of the term does present a new area.

In the Army we have established some certain rather stringent limitations on the use of the term. A project manager, first and foremost, has operational and fiscal control over his program. In some of the other Services this does not apply, and he operates as a staff officer. But he not only has the responsibility and the information on what is going on; he also controls the resources which will accomplish these objectives.

AMC adopted the principle of project manager as an essential and significant element of its organizational philosophy from the first days of its existence. General Besson made it clear that he regarded these individuals as personal representatives to exercise full authoritative direction of their assigned areas as they saw fit. They are given full control of all the resources required by their program and are expected to take prompt and vigorous action whenever necessary.

The project manager is given line or command control over all the people throughout the AMC complex who are engaged full time

on his project, be they scientists in the laboratories, engineers on the drawing boards, or contract-quality assurance personnel in the manufacturer's plants. Additionally, they may call on all elements of the command for such temporary support as they may require to perform special tasks for them when necessary.

The project managers report to General Besson and higher levels — often including the Office of the Secretary of Defense — through a series of reports, including PERT/COST, Line of Balance, and monthly significant action reports and briefings. Decisions are effected through the project managers often by oral instructions issued at these briefings.

You may have noticed in this tabulation of the array of controls to which our commanders are subjected that none of them represents the comptroller. Indeed, the channels between the interested parties seem deliberately to bypass this organizational element.

Since the Army Comptroller organization owns the financial accounting structure, we are of course responsible for the control and accounting for the monies entrusted to our care. Periodically we report to our commanders the status of their funds, though the odds are that they have already been apprised by the specific activity director.

Nevertheless, we should recognize that all commanders are responsible for properly accounting for their obligation and expenditures. While they may be required reading only in the F&A office, these books do account for a considerable volume of the information flow up and down the channel of command. There are of course independent accounts for each of our seven appropriations. While our regulations require every one to keep a general ledger account, this is a meaningless piece of ritualism which we have insisted on because it is good accounting practice rather than because it has value.

Commanders must generally be aware of the state of expenditure of the resources. However, they are mainly kept aware of these by the program or activity directors whom I have mentioned previously. Usually by the time the F&A officer walks in to say that the commander is running out of money, the commander knew it two months before from the activity director concerned.

This does, however, account for a considerable volume of paper work. There are some conversations, and I assume somebody from the Comptroller of the Army will discuss whether this flow of paper work which is required because we must account for money, should not be integrated with program reporting channels discussed earlier.

Interestingly, we of course require each one of these commanders to keep a general ledger account, and this theoretically is a control I have never found anybody who could either read or justify. But

I have never found any accountant who could agree that we could do away with it.

In the past few minutes I have listed some 10 or 12 different controls to which our Army organizational structure is subjected. Some of them are rather unobtrusive and present no particular difficulties, while others, such as the O&MA program and budgeting system, impose significant workloads throughout the Army.

While this catalog may have been exhausting, it has not been exhaustive, and I am sure that any of you could expand the list at least fifty percent with no particular effort. Additionally, while they are outside the scope of my definition of control, similar difficulties inflict the commander in the paper work and delays encountered in securing approvals and authorities which are reserved to higher echelons.

The primary impression which I would like to convey here is that there is a tremendous amount of information on all conceivable aspects of our operation flowing into the top echelons of the Army and the Defense Department. And we should give some recognition that all of these controls are superimposed upon a body of laws, regulations, and directives that give specific direction of how to do everything from cooking a stew to stocking parts for our jeeps.

On the other hand, while the executives of Ford Motor Co. or Safeway Stores might gall under the load of these regulations and controls, why should military commanders object to being given specific directions? We expect to be told what color socks to wear and how to walk, as well as what to do — an Army takes pride in its discipline! Yet the subject of "overcontrol and loss of command prerogative" is almost the only active subject of conversation in Army circles today.

I think there are two principal reasons for the popularity of "overcontrol" as a gripe-session subject today. The incompatibility of the controls and inconsistencies between them and certain generalized standards of behavior and housekeeping on the one hand, and feeling of frustration and helplessness amid the welter of reports and studies on the other.

The strongest of these pulls are those between echelons in the program system on the one hand and the command structure on the other. We prepare elaborate impact statements of budget and program implications which are argued heatedly and tediously entirely outside the cognizance of the commanders. Allowances and decisions of vital importance are channeled through "responsible staff orders" with little opportunity for command level consideration. The post commander cannot keep his post to the appearance standards his Army commander might like, unless his maintenance people get support through *their* program channels. Slowly, our generals

become resigned to conducting their operations as their staff officers advise them. The real business of the Army moves over into functional channels more and more every day.

The problem of over-reporting is too well known to require discussion though perhaps it may be well to remind ourselves that we now have to keep track of each action from so many perspectives that our information system is a pyramid standing on its head. For example, each purpose is reported with respect to its: 1) type of procurement instrument; 2) type of business; 3) commodity; 4) type of funding; 5) type of inspection; and many, many others.

The much touted Autoprobe is an attempt to do all this book-keeping by computer, but I am not sure we can design the pyramid big enough to accommodate all the interested bystanders.

Is there a solution to this dismal picture? Are things going to deteriorate from bad to worse? Already a good quarter of the people in AMC are engaged in the command control system, as I have tried to paint it here. Certainly, almost all at our mid-management and headquarters level can be so classified. Each of these systems by itself sounds so logical and orderly that it is hard to say that any could be eliminated; certainly it would be difficult to persuade any of the staff elements of any headquarters to give up its system, though they might concur in the elimination of someone else's.

I think, however, we are going to have to eliminate some of our program controls and reduce some others to special reports for *ad hoc* analysis. We are going to have to go back to some reliance on directives and regulations and our military discipline system before we drown in this sea of paper.

Take the *staff responsible people*: does that strike you as a conflict in terms? It is, but you have gotten so inured to it that the "staff responsible person" as a term has become accepted. Actually, there is no such thing. Staff officers are *not* responsible, but they *are* responsible. We are going to have to find some way that they can conduct their analyses and perform their responsibilities to their commanders, not their responsibilities for programs, without these elaborate control systems. If we don't, we are going to drown in a paper sea. We have survived basically on the fat and the excesses we have built up in times of emergency. You may have noticed — and this is another control — the direction to the DOD to eliminate 25,000 civilian spaces this year. That is a control, isn't it? It was said that, for the first time since 1950, we are getting below a million men. We must have enough people on board to do our work, unless we find some way to do less, because we have eaten up all the fat by this gradual process of improvement, and we have not eaten it up by eliminating any of our excess command and control

and staff supervision systems. And these are the ones that have got to go.

The job of the comptroller of AMC is to balance plans, programs, and funds in order to come up with a program of action.

Organizational students frequently comment on the genius of the Catholic Church, which has designed a system with only three layers of management between the parish priest and the Pope.

They have another thing that I think you should consider, and that is that they do it with a book that is 2,000 years old and with no reports.

I think control students might look at their success in governing a worldwide operation by the use of simple directives and discipline in lieu of reports and staff reviews.

## SOME PROBLEMS IN MANAGING A MILITARY INSTALLATION

Major General  
CHARLES W. G. RICH  
Commanding General  
U. S. Army Infantry Center

For the past 5½ years I have had three different tours of duty which have involved me in the day-to-day, as well as long-term, management of a post or military installation. I have had two tours of duty at Fort Campbell in addition to my current one at Fort Benning. I note from the biographies that many of the students here are currently involved in some of these day-to-day or long-term duties of managers, so that at least I can point out that my qualification to speak rests on the fact that I have been exposed to some of these management problems in my past as well as current position. Or possibly my qualification rests on the fact that I am a graduate of this illustrious school and have been here several times as guest speaker. Of course, better yet, I guess, we could get into a straight assumption, and that is that the DA has seen fit to assign me as installation commander at Fort Benning, and thus you will have to accept the fact that I am qualified.

### DUTIES

Let us take a look at what my duties are at Fort Benning: I wear three hats. I am the installation commander, and as such I report to the Third Army Commander, General Watson. I am the Commandant of the Infantry School, and as such I report to General Waters, the CONARC commander. I have one other hat. I am also the test director for Project TEAM (Test Evaluation of Air Mobility). This has to do with the organizing, training, equipping, testing, evaluating, and controlling of the 11th Air Assault Division, the 10th Air Transport Brigade, and the TEC Group (Test Evaluation and Control). I report in that particular case to General Beach, who is the Commanding General of the Combat Developments Command. Thus my first management problem is to satisfy three different

---

*General Rich graduated from the U. S. Military Academy in 1935 with a B.S. degree and was commissioned a second lieutenant, Infantry.*

*During World War II he served in the 19th Infantry in Hawaii, where his assignments up to early 1943 included S2, S3, and Commanding Officer of the 2d Battalion. Until late 1944 he served at the Infantry School, where he attended the Basic Airborne Course, was S3, then Executive Officer of the Parachute School, then*

bosses. I might add that only one of these gives me the money and resources to carry out these three jobs.

I do not know what your definition of the management problem is, but I see it this way: 1) *What is my mission?* 2) *What resources do I have?* 3) *What problems must be overcome in order to accomplish this mission?* Putting it another way, I am a chef. They toss the various ingredients to me, and it is up to me to come up with some kind of tasty casserole dish that will suit all the people who are going to eat it. So let us sally forth here and take a look at what the job is.

#### SIZING UP FORT BENNING

Fort Benning is located in western central Georgia. A small portion of it, about 11,000 acres, is located in Alabama. The remaining 173,000 acres are in Georgia. The Chattahoochee River, which is the Alabama-Georgia boundary, runs north to south through this reservation. Columbus, Georgia, is contiguous to the northern boundary of the post; Phenix City, Alabama, is contiguous to the western portion of Columbus, although the boundary between the two is also the Chattahoochee River.

Fort Benning has a total of over 284 square miles, or 183,000 acres. We have 45,000 military personnel assigned, 45,000 dependents, and 5,500 civilian employees, so that we have a community of about 90,000 souls. At Fort Benning we have the Infantry School, the principal reason for its existence, and the 2d Infantry Division, a STRAC Division. We have the 11th Air Assault Division, in part, as it is building up to its total division status. At the moment it has moved into Phase II, which is the brigade stage, or approximately 9,000 people. It will operate like this until July 1964, when it will become a full division. We also have various other troop units, about 50% of which are STRAC.

---

*Commander of the 2d Parachute Training Regiment at Fort Benning. He served in the ETO from late 1944 until summer 1947 with assignments ranging from Airborne Advisor, 6th Army Group, to Assistant to the Deputy Chief of Staff, EUCOM.*

*Upon return to the U. S. he was assigned to the AFSC, Norfolk, Virginia from August 1947 to July 1950 as student officer, instructor, and College Secretary. In July 1950 he was assigned to the 82d Airborne Division at Fort Bragg, North Carolina. He attended the Army War College in 1952-53.*

*His next overseas tour was in Korea (September 1953-September 1954), where he served as CO, 15th Infantry Regiment, 3d Infantry Division, and Deputy Chief of Staff, Headquarters, IX Corps. He was assigned to Washington, D. C. from October 1954 to April 1958 in the office of the Deputy Chief of Staff for Personnel.*

*Beginning in May 1958, General Rich served for 16 months as Assistant Commander of the 101st Airborne Division, Fort Campbell, Kentucky. From late summer 1959 to early summer 1961 he served as Commandant of Cadets at the U. S. Military Academy.*

*General Rich commanded the 101st Airborne Division and Fort Campbell from July 1961 through February 1963.*

*(The present paper was prepared from the transcription of an oral presentation given at USAMS, Fort Belvoir, Virginia, on 1 November 1963.)*

## MISSION

This is my mission: Constant training at the Infantry School of officers and noncommissioned officers of units that are on the post; and, as installation commander, rendering support in order that the readiness of all units may be in such a state that they may move out at any time required. (As a matter of information, I might mention that Fort Benning last year had the interesting but difficult job of rendering all the logistic support, generally speaking, for the Cuban crisis.)

In my role as Commandant and Commanding General of the center, my job is to maintain and support this readiness. To put it another way, my job is *not* to do this. Part of the management technique these days is to give a fellow all the jobs you used to, but it is his job to determine those things he cannot do within his mission because of a shortage of resources. Therefore he can defer this or that. Well, you cannot defer the training requirement and you certainly cannot defer the readiness requirement. So certainly I must not forsake these two.

## RESOURCES

Now that I have told you about the place and given you my mission, let us see what my resources are. The first thing you do when you have a job is to figure out what your total requirements are. You all know this. Since we never get enough resources from the Army to do our job, we have to indicate within these total requirements those that we consider essential and those that are not so essential. Of course we end up with whatever the resource-giver provides us in the way of resources.

For some reason or other the engineer R & U has become a soft spot for management experts. They still agree that you have to eat. And they still agree that you have to sleep and that you have to get paid. So they do not touch your civilian pay and a few other related items. But for some reason they do not think that a room has to be warm, or that it has to be lighted, or a window or latrine has to be fixed. All those things can be deferred. So R & U is something they always take a crack at. And it represents quite a sizeable figure.

## SHORTAGES

Now let us identify our shortages. We have under "essential shortages" the following: air mobile test units, \$12 million out of the \$17 million total shortage for field maintenance, combat forces,

Infantry School, etc. How did I arrive at this figure? Our reasoning was as follows: In order to maintain the 11th Air Assault Division at Fort Benning during this brigade phase, it is a must that we use practically all of the old mobilization housing remaining on the post. Some of this housing has not been occupied since the end of the Korean War in 1953. It takes, in many cases, between \$4,000 and \$6,000 just to renovate one two-story mobilization barracks. That is the state that they had gotten into in ten years, because they have been in the deferred maintenance category that long. The field maintenance requirements are also related to the 11th Air Assault Division needs, either directly or indirectly. The combat forces item is related to the 2d Infantry Division, which is a STRAC unit, and also to the other troop units on the post. The USAIS item is related to the Infantry School. As an example, within the past six months the OCS program at Fort Benning has been expanded 200%. We are turning out three times as many OCS graduates as we did six months ago. Fort Benning now has the job of providing airborne replacements worldwide. During the Korean War, ten years ago, Fort Benning was producing 17,000 airborne replacements a year. At this moment we are turning out about 25,000 a year, and by next year it will be in excess of 30,000. So the airborne replacement job has been increased about 100%. These are some of the justifications for putting these in the essential shortages.

There are other shortages which add up to \$3 million, and which of course, along with the \$17 million, make a total of \$20 million. Here we have activations and organizations, which are programmed by DA; medical activities, which are a proportion of the total medical requirements; and some more combat forces requirements. These are things which are programmed but which we will not be able to do, at least the way I have it figured at the moment. Take, for example, certain units which are supposed to take amphibious training. We will be able to send some of them, but not all the ones that should be sent. Installation support activities, as well as engineer projects account for over \$5,000. Actually, this is the first time it has ever been that low.

You can see where our \$52.5 million in resources comes from. First, the Third Army gave me an AFP of \$46.3 million; we have our local automatic reimbursables—reforestation program, laundry, etc. We get \$4.5 million from that, and we had \$1.7 million in 1963 obligations carried over into this year. So that adds up to our \$52.5 million in available resources.

Now that we have marched our way through this, we find that we are still 20 million dollars short, divided up into those two increments of essential and other shortages. I would like to refresh your memory once more. I have my mission as Commandant, training

officers and noncommissioned officers in the Infantry School; my mission as Post Commander, supporting the 2d Infantry Division and the 11th Air Assault Division and all other TO&E units on the post which are members of either STRAC or STRAF. And, in particular, my mission as Test Director is to test and evaluate the 11th Air Assault Division. Of course I also have to provide the resources for these things. (I think here that I might also add that what I have discussed is the program picture. Sometimes things are not as they appear. I think this is the difference between a program and day-to-day life. The planner makes the perfect plan and the operator always messes it up. The operator of course has to put up with new circumstances since things do not come out as it appeared they would.)

#### "NOT IN THE PROGRAM"

In operating the place, a few things come out that are not in the program. I would like to give a few examples. I have only been at Fort Benning since February 1963, but some of the items that have come up since then were not foreseen. We had a little problem on Mother's Day, for example. At 1145 hours a fellow rode up to me on the golf course and said General Truman would like to talk to me on the phone at once. The General stated that they would like to have a battalion placed in helicopters and moved to Birmingham, Alabama, immediately. (I was at Pearl Harbor when the Japanese attacked, and that incident took place at five minutes before eight on a Sunday morning. It was pretty difficult then to get hold of people. But I can assure you that at noon on Mother's Day it's a hell of a lot tougher.) Everybody had decided that, because it was Mother's Day, they would take off. I did not catch my Chief of Staff, who had left fifteen minutes before. Just rounding up people was something out of this world.

In any case, to make a long time story short, it took us quite some time to round up this little force and put it in helicopters and get it over to Birmingham. After we got there, they would not let us land, and so we ended up back home and then to Fort McClellan, where we stayed until June 1963. Mother's Day was the 12th of May. That money came out of the installation commander's pocket, and it was a fair amount.

Along about the first week in July I was told that we were to have a little test (Coulee Crest). The Army had put together rather rapidly a trial organization of Mohawk aircraft and personnel in which it was selling a combat surveillance principal. But this had not worked very well, so the Vice Chief of Staff said we were going to do it and do it right. We were going to put these two units in

Swift Strike. They were to be assembled at Fort Benning on 9 July and the training would be finished on 30 July.

You cannot organize an infantry squad and train it very well in three weeks. If you have ever tried organizing an ASTA platoon (Aerial Surveillance), which is composed of Mohawks, you can understand this. You have three different kinds of Mohawks. One you look out of and take pictures from, another you look out of and have a side radar called SLAR, and another you look out of and have an infrared picture operation. The people who operate Mohawks are pretty scarce, the people who operate all of this equipment are pretty scarce, and the equipment itself is pretty scarce. For instance, I went down on 9 July and talked to the colonel whom we had gotten to run this show, and the lieutenant colonel, who was the deputy. They told me that they had all but four officers, who were supposed to be our aviators; these were coming in from Germany. Just as though they had planned this, while I was standing there, in walked these four officers from Germany and reported for duty.

In three weeks they did something I did not believe could be done. They turned out two good ASTA platoons; we put one on the Blue side and one on the Red side during the maneuver and they did a remarkable job. We found that they could really use this equipment and produce results with it. We showed General Sweeney, the commander of TAC, what we were doing, and about 10 days later in came ten Air Force officers "to catch up with the Army"! But this too cost money and it came out of the same place it always does — the installation commander's pocket.

Now we have just received word that we have to form an ATRI company (Air Traffic Control operation) which controls all the aircraft in the air in an Army area. We received this the other day and we thought we had a company, but we did not; we had a piece of paper and two lieutenants who were assigned to it, but none of the experts were there. That is going to cost some money.

We just moved in the 98th Ordnance Co. from Fort Stewart. This is another little outfit like these extra airborne guys and these extra OCS students. It takes money to support them. And when our budget was made out quite some time ago, these items were not in it. I might mention that the Mother's Day operation had a price tag on it of about \$185,000, which I am trying to get money for. This is another item that is very unfortunate, because it does not appear in our management process but is something that happens to every unit commander every time one of these unprogramed things occurs. You take the program you have and figure out what would hurt you the least and you slide it over to the next year. I am in the process of picking up what was "slud" from last year.

General Harroll had to fight Cuba, so he slud a few things over; then I had to fight Mother's Day, and I slud a few; and now I have them both. These have to be taken care of, but they were not in the program.

#### MANAGEMENT CONSULTANT EXERCISE

I would like to depart at this point from my normal procedure as a guest lecturer and move into what I consider an interesting exercise, that is, to delegate each one in the audience as a management consultant of Fort Benning. I think you are far enough along in your experience and in this course to provide me with your high priced consultant advice on what I should do at this point. I might add here that, since I have been at Fort Benning there is some information you have to have to analyze my problem. We have been visited by Secretary McNamara; Secretary Vance; Assistant Secretary Ignatious (I & L); Assistant Secretary Larsen; the Chief of Staff of the Army; the Vice Chief of Staff of the Army; General Waters, the CONARC Commander; General Harrell, the Chief of Staff for Force Development; General Beach, CDC Commander; General Watson, the Third Army Commander; and a host of others. They have always impressed on me that the Army's No. 1 project at the moment is Project TEAM, the 11th Air Assault Division's organizing, training, equipping, and testing. I hasten to add that this 100% emphasis has not been reflected in resource channels to the degree that these individuals have indicated this to me in their oral exhortations.

So please put on your consultant's hat, take a look at my situation, and give me your advice. At the end of our advice period, I will have a short summary and tell you what I have done and what we propose to do.

Q. Have you been told that you will not get additional monies?

A. I received my AFP about three to four weeks ago. I have put in three different reclamas and I have received an answer to each reclama which provided me with what I consider minuscule assistance.

Remember, I think I ought to impress on you that I go to General Watson, who has ten big installations in the Third Army, and present him with my problems. He has a management problem, too. But I keep saying that, as regards the 11th Air Assault Division, Mr. Vance, General Wheeler, and General Hamlett have told me to "go, go, go." But he said that he did not see anything in the piece of paper that came down here ("You'll get your fair share").

**Q.** I am certain that you have decided what projects that you will not do in the event you are not given assistance.

**A.** Are you speaking of the relationship between essential shortages and other shortages, or that I have taken the essential shortages and decided that I will not do them?

**Q.** Well, I think that perhaps you are going to get into the essential shortages.

**A.** You remember that the essential shortages were \$17 million, and \$12 million of that was directly 11th Air Assault Division requirements, while some of the others had an indirect relationship to them.

•

**Q.** Sir, you're just going to have to cut out some of your missions. You can't do everything. You have got to either trim some of the support, or you are going to make kids walk to school, or cut down on other areas. You just can't do it with what you have unless you take a long, hard look at your requirements. Go through your priority lists and list them by order of priority. Start at the top and do those that you can do with what you have available. The rest of them are going to have to be "slud."

**A.** On 18, 19, and 20 November 1963 I am going to have at Fort Benning the Army Mobility Symposium for the Association of the United States Army. The theme of this is "Mobility, Both Ground and Air." This time I am going to have Secretary Vance and General Wheeler there to take a look at it. At the same time, I have to give them a manager's report on how I am doing this. Are you suggesting that I tell him that, because the 11th Air Assault Division budget this year is \$34 million and they have only funded \$22 million of it, I should cut out 12/34th of what we are going to do with the Division?

**Q.** No, sir, I think that has your top priority, from what you've said, but you're going to have to take something from some other activities and perhaps reduce some of the OCS training. I don't think the quotas are being filled anyway, from what I understand. Or you'll have to cut down on your airborne training. You'll have to line up what you have to do in order of priority with what you have available; it has to balance.

**A.** I just received a letter from General Waters saying that the DA had told him one of their greatest problems is the procurement of officers for the Army for the next 24 months. Any of you people who are at installations received your copy of the same letter. It said that they want you to go out and look at your boys, pick out the best of them, and then say, "Here is an opportunity for you to be an officer." You line them up, talk to them, and induce them to go to OCS. The same letter increased my authorized spaces for

Fort Benning instructors by 40. In the same mail, literally, I got a letter from the Army Commander that said my share of the second quarter shortage was so much, and the net ended up a minus.

We have increased the size of OCS in a number of classes. We've had to organize new TD units to take care of them. We used to have three companies; now we have seven. We have to have new instructors. We have to have more problems, shoot more ammunition, maintain more vehicles, do everything — and this all costs money.

I should have added that I submitted a reclama and have received a favorable answer on personnel and money. I have received some more money and some more authorized spaces for personnel; but I also received word at the same time that, although our authorization had gone up, our manning level had gone down. Of course, as you all know, the authorization doesn't mean anything; it's the manning level that counts. This is like having 20 checks, but the only one you can cash is the first one.

•

**Q.** Sir, in addition to selecting items that you have to place in an unfinanced category, you probably will have to reduce the level of support for some of the activities, particularly your primary mission. In other words, the school itself will probably have to be reduced in support level.

And, at the same time, I'm sure that the unfinanced items for the Air Assault test team will have to be whittled some as well. To do this, I'm sure that, by necessity, you'll have to go back to your Army commander and specifically identify to him the items which are unfinanced.

**A.** This is correct, and this was a part of my reclama which I mentioned. I told him that I was going to have to do this. I don't know what your family is famous for in its home town, but let us say that it's famous for its gracious hospitality. At Benning we consider our hallmark is our method of instruction. We think we instruct better than anybody else. One of the reasons we are the best instructors, we think, is because we have an instructor training course. When an instructor comes there and he goes into that, he stays a month; he doesn't go on the platform. Then when he arrives at his department wherever he's assigned, as a result of the instructors' training course they learn what he's best fitted for. We then assign him to his section. He goes over there and learns about this; he watches and performs and then he gets on the platform and does a damn good job, because he has had the opportunity to properly prepare himself.

At the moment the two sections that have the greatest number of instructors are Weapons and Tactics. One is manned at 51%; the other is manned at 48%. This means that each gentleman is now performing twice as often as he should be. Actually, a little more than that, because you always have your group of managers at the top. This means that he doesn't have time to do what he should: research his problem and make it better each time. So I find that our instruction, in my opinion, isn't nearly as good right now as it ought to be. The gracious hospitality that I'm supposed to be famous for is now, "Come in and have a quick sandwich. I don't have time to furnish you any coffee." So we are in bad shape at the moment, not just because of money or materiel, but because manpower is short. Of course you all know that these are the three things that you need to get things done.

•

**Q.** Sir, isn't one of our problems the fact that each time the new missions come off, we absorb it and keep cutting down on these various areas, and as a result we keep on getting less and less with more and more missions? Should we take a concrete position when they do assign these new missions and say, "No funds, no missions"?

**A.** Yes, and I have said this. I'll give you a good example. When I was with the 15th Infantry in Korea, the motto was "Can do." When you handed a fellow a job, he saluted and said that. Since I've come back from Korea, I think that is a great motto. Another motto over there was "No sweat." But when a guy says "No sweat" to me now, that's when I start shivering. Because this means that he already has twice as much as he can do but that somehow or other he will manage to get it all done.

•

**Q.** Sir, at this time how do your essential shortages compare with the essential shortages of FY 63?

**A.** Last year, until the Cuban crisis, things looked pretty good. If you remember, the Cuban crisis hit us on about 17 October, and this was about the same time the annual funding program came in. When you start to fight a war, as you well know, you can't stand around and ask, "Where are your requisitions?" You have to move, and we did move. The answer down through the comptroller channel was spend your money out of the third and fourth quarter; we'll have to make this good later. So we went through this exercise, and in the third quarter we went broke. Then they told us to spend the fourth quarter's money, and they finally said, "OK, we're going to

refund you your Cuban money." So here's what they did. They told us to list all our money spent on overtime and they'd refund us this. We said, "Wait a minute, those same guys down in the ordnance shop worked eight hours during the day on Cuba and then they worked six hours overtime on Cuba." We hassled for some time and we finally got the money for this on about 25 May; around this time we were just getting out of the Mother's Day operation. But the aftermath of this whole thing can be seen in the example of the post engineer. He spent a great deal, almost all, of his time on Cuba. We were refunded certain monies, but the job that the Engineers were programmed to do didn't get done and was "slud" into FY 64.

I might add that the job I was given to do was to establish the 11th Air Assault Division, building helicopter pads, fixing up barracks, and so on. We could do it cheaper with troop projects than we could on contract. So, to answer your question, the unprogramed items related to Cuba we were paid for on the surface but the scar is still there. It's quite a little scar and the plastic surgery to cover it has not yet been accomplished.

•

**Q.** I don't have a solution, General, but I might have one consolation for you. I'm from the Aviation Materiel Command at St. Louis, and if we don't get some money also to buy some parts, the 11th Air Assault Division planes aren't going to fly either.

**A.** When we started the 11th Air Assault Division, the problem was personnel. And then it shifted to equipment. Now, to our surprise, they are delivering Caribou aircraft and Chinook helicopters on the schedule that they had set up quite some time back and they are adhering to it. In fact, not only that, every now and then you get a little bonus out of this. We're now in the astonishing situation where we're short pilots to fly the aircraft being provided to us, and my consolation to you is that, if we don't have the pilots to fly them, we're not going to need the parts to maintain them.

•

**Q.** General Rich, I think it might help your management consultants if you could break down the \$12 million that you need for your Air Assault Division, and tell us to what extent, if any, you plan to "slud" these requirements over, say, to the third quarter and then to the fourth quarter, with the hope of being baled out at the tail end.

**A.** The answer to that question is very simple. I have programmed the 11th Air Assault Division on a 34-million-dollar basis and we are operating full speed ahead. I've had enough people tell me

that the 11th Air Assault Division is No. 1 priority. I haven't any question in my mind that we're supposed to be doing this. We may close up shop about 2:00 in the afternoon on 11 February and all go play golf, but we're going to operate 100% until then. Maybe I could assist you by identifying some of the missions of the school. People talk about priorities; now let me tell you some of the things we do. Then you can say, in your judgment, which one of these we ought to cut out.

The senior course, so to speak, at Fort Benning is the career course consisting of 400 individuals, which includes about 22 from foreign nations. They take a nine-month course and are divided into two classes only because our classroom capacity is 200 persons.

We also have the associate career course. The first group are captains who have anywhere from four to ten years of service. This consists of a course half as long as the regular course, about 18 to 19 weeks. Here we have individuals a little more senior who didn't get to the career course. They might be Regulars or Reservists and could also be National Guard and Reserves not on active duty. We have about four to five a year, and each has 200 in the class. In effect, we take experienced Infantry officers and give them a postgraduate infantry course. Then we have a class called the Orientation or Basic Course, and we run every lieutenant through this who comes into the Army. These lieutenants are officers who have graduated from West Point or the military colleges or ROTC around the country. We run about 3,800 of these through a year in classes of 200; they take a nine-week course. In effect they come into Benning as second lieutenants, and, although they are only there nine weeks, they go out in theory as second lieutenants of Infantry. And that course costs a lot of money and effort.

Then we have the OCS. This is where we take noncommissioned officers of the Active Army and train them to be officers. We train them for 23 weeks and graduate them as brand new second lieutenants. They do not go through the Orientation or Basic Course. When they graduate, some 26% of them go into other branches of the Service; the remaining 74% go into Infantry units. We will have 2,000 of these in FY 64, starting them in classes of 200 and graduating about 2/3 of the number that enter. In the Airborne course we run a class almost every week. Out of the 52 weeks a year we run 45 to 48 and this class starts with about 470. Our loss in this is about 15 to 18% for various reasons.

These are the major items that occur in the Infantry School. We have many other items: refresher courses, communications courses, mobility courses, all kinds of extra courses. Throughout the year we probably run 75 to 100 classes through 14 different

courses. This amount of money to run the Infantry School is somewhere around 12 million dollars. But I think I should add one more item for your consideration. Speaking of the \$52 million, breaking it down into hard and soft items is one of the management techniques used quite frequently. For instance, the first item is civilian pay. I'm quite sure you are aware that this is a pretty hard area to invade, because the civilians must be paid. The number of civilians on our payroll at Fort Benning is 69.6% of the number that Third Army says that we need to do our job. Out of the \$52 million, \$17 million is in civilian pay. Combat forces account for \$17 million. Supplies, equipment, and other contracts account for \$10 million. Each of those figures has been sifted and squeezed.

•

**Q.** Sir, do you have civilian instructors in the schools?

**A.** We do not have civilian instructors to amount to anything. The man who gets on the platform itself is a man in uniform. One of the biggest things we run at Fort Benning, which I haven't mentioned to you, is the Department of Nonresident Instruction. This has 330,000 students, and we keep active files on them. This quite obviously has to be automated. In the automation operation, however, we have a large number of civilians who I am sure would come under the category of instructors.

•

**Q.** Do you have indirect reimbursements coming into the post other than what you have mentioned?

**A.** No, sometimes those figures might be a little higher than you think and this might provide you a little assistance. The main source of this is the reforestation program on the post with 185,000 acres. We have a lot of timber and there is a large lumber program in which we sell lumber and get the money for it. This goes in as part of our funded program.

•

**Q.** Could you close your schools and send your kids to public schools?

**A.** No, that's a line item in the budget. You send in your average daily attendance and they'll fund that. For instance, our daily attendance for the number we had enrolled this year is not going to be nearly enough, but this is a credit accruing operation. Your average daily attendance makes that figure come out a million

five; HEW will support it. That money comes from HEW. It comes to you through the Army, but it gets funded. So I would not save any money there.

I could save money in lots of other places. You'll notice, as an example, the USAIS shows \$3,152,000. That figure included all of the things that are related to the USAIS, a goodly number of which are in combat forces. But we have school troops at Benning and all the money for the 197th Brigade, which includes infantry, mechanized infantry, artillery, and engineers, comes out of combat forces; but they are related to the support of the Infantry School.

•

**Q.** You might consider eliminating your officers' orientation course. I believe that consists of about 3,800 people. You might consider OJ'ing these people. We actually had some who came to us before going to Benning. They performed pretty well; I'd hate to see it happen, but it is one extreme measure you might consider.

**A.** Thank you, such a paper is prepared and sitting on my desk at the moment to be signed.

•

**Q.** I think you could also eliminate the postgraduate course, sir.

**A.** I may have given you the wrong impression when I called that a postgraduate course. Let's ask General Cassidy which one he would keep, if he had to eliminate every course in his school except one. The career course. This is the officer taking his Master's or Ph.D. in his profession. I had referred to this as the postgraduate course.

**Q.** I was referring to the courses that sometimes senior officers take who are going back to Infantry as commanders.

**A.** That's the refresher course and we have three to five of those a year. It is of small order of magnitude.

•

**Q.** Sir, what type of austerity have you instituted on your supply and equipment, especially to stretch out on equipment replacement?

**A.** We're operating at the moment on about 18% per quarter operation. And this just about comes out to what we have been given. In other words, we are not using money in a maintenance way up to the program of the requirements. We're only expending on an 18% operation as against 25%, so that would be 72%. We are doing that until we see how we end up in this money hassle.

**Q.** What can be done to downgrade the 2d Division as you increase the capabilities of the 11th Assault Division and transfer the money and mission to it?

**A.** From 1 August until 31 October the 11th Air Assault Division moved from a battalion-slice operation to a brigade-slice operation, and this was done by individual fill. It is now planned that when it goes from the brigade size to division size by 1 July 1964, to have a unit fill, which is what you're speaking of, but that will be one day too late to solve my problem in that area. In other words, this will be a problem for FY 65.

•

**Q.** You said you reported to three bosses, sir, and I believe you said that you reported to General Beach. Have you attempted to get any relief from that source or through that channel?

**A.** I am going to defer the answer to that because it is in my conclusions.

#### CONCLUDING REMARKS

First off, let me say that I appreciate your many constructive suggestions. As usual, I find the student body most receptive in analyzing the management problems of an installation commander. And I also would like to say that I consider myself most fortunate to be commanding the largest populated post in the Army, as well as one where so many varied operations are going on. I should start my conclusion by saying, first, that I have already been through the second and third reclamation for resources before I came here. And I might add that I had to revise my figures, because last Tuesday I received \$2 million plus two personnel vouchers which gave me a few more people authorized. Second, when General Waters and General Watson visited Fort Benning recently, they were seeing a part of the 11th Air Assault test. I discussed with them the principles of considering the 11th Air Assault Division funding situation as separate from all other items at Fort Benning, even Third Army and CONARC, and suggested that the principle be proposed to the DA that if the 11th Air Assault Division is to have 100% priority, this be so stated and that it be funded 100% from resources Army-wide. Also, that the remaining missions at Fort Benning receive their fair share or what, in General Watson's and General Waters' opinion, is their fair share.

Referring to essential shortages, according to this principle you would get a special voucher in which you would get this \$12 million dollars. You would also get personnel authorization for some 300

civilians and some 250 military spaces would be filled. And the civilian spaces would be made available to you immediately so that you could then say that the 11th Air Assault Division would get what we consider it needs.

We reviewed our various missions at Benning and we placed them in priority to see if we could then reallocate resource requirements and discuss with our respective bosses the deletion of certain missions in order to reduce our deficit funding to a more reasonable figure.

We too have arrived at the decision that the orientation course is the one that is the softest of all the courses that have any size. We decided that it could account for some effective savings. We are in the process of recommending that this be cut out, not because we don't think it is needed but because from a matter of relativity we think it should be cut out.

We are in a tighten-your-belt operation which gets into maintenance, utilities — everything that we can — and this takes in part of our field maintenance as well as the combat forces portion of our monies.

We have every staff section coming up with another review of our requirements. Remember, now, our requirements were drawn up almost a year ago. They were reviewed during the last quarter of 1963, they were re-reviewed in September, but now it is two months later.

As you can see, there is nothing new or magic about this operation. You have all done some portions of this before. It's somewhat like the construction of a Swiss watch. Somehow we have to take all the parts and get them in proper balance and then screw it together and wind it up and see if it won't keep the proper time for us. And we have to take a look at this every day in revising and updating the latest things that we have. As an example, the 11th Air Assault Division completed its phase I test on 15 October. As a result of this test, which, incidentally, was very gratifying to us, we will now be able to take a look at some of the things programmed for the 11th Air Assault Division in the future and add here and subtract there, which will also affect both the overall requirements and the attendant resources. And I hope that my case will be stronger than some other fellow's when the mid-year review comes around.

Our job at Fort Benning is the same as everyone else's job, that is, to train people and maintain units in a state of readiness in order that they can fight whenever called upon. I consider that this is truly the job of military management.

## SOME REMARKS ON MANAGEMENT AT THE ARMY WEAPONS COMMAND

Major General  
NELSON M. LYNDE, JR.  
Commanding General  
U. S. Army Weapons Command

### **Introduction**

While I am honored to have the opportunity of addressing you on the subject of management, I will admit that I was puzzled as to why I should be singled out for the distinction. Frankly, my immediate reaction was, "What the hell do I manage?" However, on reflection, I concluded that if a negative answer were valid, then the many GAO and AAA reports we have received would be pointless indeed. The question was rephrased to "At what level and to what extent am I permitted to manage?" On this basis I interrogated my staff and with their assistance I have attempted to evaluate our role and authority in the scheme of Army management.

### **Mission**

Our mission can be stated in the following numbered points:

- 1) To develop, acquire, and service weapons, combat vehicles, fire control, and tools and shop equipment for the U. S. Army, and, as required, for the other U. S. Military Services and for the military security program.
- 2) To conduct basic and applied research in commodity-oriented fields.
- 3) To support project managers and other commodity commands, as required, and, conversely, to acquire support by other commodity commands, on appropriate projects.
- 4) To assist industry in converting to quantity production of assigned commodities.
- 5) To develop qualified technical and scientific executives to promote and protect the Government's interest in its relations with industry.

---

*General Lynde is a graduate of the U. S. Military Academy and has been assigned to Ordnance and Armored unit duties a major part of his military career.*

*He served throughout World War II in Europe with the 7th, 1st, and 15th U. S. Armies. In 1953, General Lynde directed the operation of Ordnance base depots in Japan. Returning to the States in 1955, he assumed command of the Ordnance Tank-Automotive Command in Detroit, where he was responsible for development*

6) To support the U. S. Army in a limited war and plan for recovery and continuity of operations in a general war.

7) To operate the assigned arsenals in an economical manner and in accordance with Government policy.

### **Command Headquarters**

Command Headquarters is a mechanistic organization along functional lines, as prescribed by AMC. It is not greatly different from the predecessor, Ordnance Weapons Command, which has been a great help in getting underway. Research and Engineering includes all the engineering talent, except for the maintenance engineers, because of a continual overall shortage of engineers, and, more importantly, because development and production engineering can now proceed concurrently rather than sequently, thus reducing lead time. There is a trend towards behavioral organization on a spontaneous and informal basis, due to short deadlines, and I find participative groups organizing themselves to evaluate contract awards, prepare determinations and findings, and for other matters. In fact, I have just approved the Chief Counsel's entering "participate" in lieu of "review" in the job descriptions of his people to more accurately describe their work.

### **Arsenals**

The arsenals are organized in similar manner. They include a Technical Center and a Manufacturing Division. All are considered the ultimate technical authority in their field and the Headquarters cannot lightly disregard them. Arsenals are charged with engineering and fabricating experimental prototypes for test and evaluation and for generating the technical data package to permit procurement from industry. Arsenals support Army contract negotiators with technical experts who can review industry production plans and assume that quality materiel at reasonable prices is produced on schedule. Arsenals operate a limited quantity pilot production lines to maintain essential production skills. Arsenals do not undertake quantity production except where commercial concerns are unwilling to undertake it, when prices are unreasonable, or when it may be required for security reasons.

The Technical Data Package is of such importance that I believe it to be the most important product of the arsenal. Supported by

---

*and production engineering of armored equipment. In 1959 he headed the Field Service Division of the Ordnance Corps.*

*With the establishment of the Army Weapons Command in August 1962, General Lynde was assigned as its first Commanding General.*

*(The present paper was presented at USAAMS, Fort Belvoir, Virginia, on 29 October 1963.)*

the engineering services to back it up, it is sufficient justification for the arsenal system. TDP's are not currently as good as we would like to have them. There is a vast field for improvement in feedback, updating, and prompt service. It is a system that demands the utmost in automation.

### **Management**

The only weapons that Weapons Command can develop, alone and unassisted, are the edged weapons, the knives, saber, and bayonets. For anything more sophisticated we must first coordinate with Picatinny Arsenal to obtain their views and capabilities on ammunition, and, as soon as the gun-ammo relations are established, we will contact Mobility Command reference the land, air or water-borne mobility platforms to carry it. Eventually, our work brings us into close contact with the Test and Evaluation and Supply and Maintenance Commands. Frequently the availability of communications equipment will govern the issue of combat vehicles, and some of the newer weapon systems combine both a high-pressure round and a missile, causing us to contact ECOM and MICOM. Frequent reference to Hq., AMC, CDC, and higher authority completes our circle of contacts. Mathematically, there are 35,000 possible channels of communication.

Those things which the Boss watches are done well, other things are neglected. The problem is to devise a system for watching important things, without becoming so involved in details that the whole system becomes bogged down. We have three specific systems.

The weekly staff meeting attended by the staff, project managers, and directors is a two- to three-hour session on Tuesday mornings, conducted by the Comptroller and Director of Programs. The first event is a 7- to 8-minute presentation on some current problem, followed by a brief status report from the project managers, then a run-down on production problems, and, finally, an opportunity for each staff officer to bring up anything of interest. Informality is the keynote and anyone may contribute to the discussion. It affords an opportunity to probe into all sorts of matters, and for me it is an excellent way to issue guidance and to call for further reports.

### **Program Managers**

The program managers have exceptional authority but may be hesitant to exercise it unless they are certain of command support. Once a week the program managers meet with the deputy commander and the directors for a Board of Directors meeting. The entire experience and resources of the functional organization is thus available

to the program managers and I feel encouraged about the system for two reasons: first, there has been no deviation between a program manager's actions and the command position, since the directors' meetings were initiated, and, secondly, because on occasion the program manager calls for a special meeting to help him field a hot problem.

While I am on the subject of program managers, let me say that I am for the system. The commander cannot do his job for doing his daily work. It is a comfort to know that a small group of selected people are devoting their entire time to watching something that I can't devote time to. I am happy to know that costs and schedules are under continual surveillance and I am happy to receive the intelligent and balanced solutions that result from these efficient people. I am doubly grateful when someone in higher authority calls for the program manager to come in to present a briefing rather than calling for the commander, as was the custom in the past. I like the system so well that I have established one or two project officers for special matters, on my own, and the problem of increased vertical management is currently under study in the headquarters.

### **Quarterly Review**

Our third management system is the Quarterly Review. Each office, division, and directorate is required to report quarterly on its progress in meeting programs. Four management areas are required to be covered:

*Program analysis* covers the costed programs, and the review is opened by the Comptroller, who establishes the value of each program.

*Materiel* is our business and each element is expected to report on some contribution made to a materiel program.

*Command and staff* is required because each element not only operates but also supervises operations in the three arsenals.

*Personnel management* is everyone's business, since a primary duty of a staff officer is to continually seek out people capable of assuming greater responsibility.

I get a "quick and dirty" report from the principal officer of each element a few days after the close of the quarter. The formal publication and the detailed briefings follow much later. I make a point of attending the reviews, which last for one to two days, and I insist that the workers do the presenting. This broadens my contacts, allows me to talk to the people that do the work and builds their confidence.

I still find that, despite all of these reviews and briefings, there are still a lot of things that have to be looked into. The people that prepare the reviews need instructions in charting techniques, and the

material they include for reviewing is too voluminous and often does not cover the subject adequately.

I feel that when it comes to management, it is not how much you do today or even who does it, but the plans you make for operating your business during the period four to five years from now are the important thing.

It takes a full eight years to secure the approvals, funding, and erection of a building, even with all the signals in your favor. It takes three or four years to obtain a major modification or conversion. Since no commander ever stays that long in one spot, it's obvious that if your predecessor didn't do some forward planning, you will get along without new accommodations.

Someone has said that the half-life of an engineer's knowledge is five years. This means that an engineer more than 10 years out of school is hardly an asset, unless his store of knowledge has been upgraded.

Further, we have far too many uneducated people in the Government service and something must be done. Unfortunately, our area at Rock Island has no technical college, so we have done the next best thing: We have enticed the school to come to us. For example, beginning with the fall semester, two dozen executives are enrolled in an Executive Seminar being conducted on the arsenal by the faculty of the Business College of the Northern Illinois University. Courses are conducted on Tuesdays and on Saturdays, part on my time and part on the employee's time.

In concluding, let me say that it's not much, but it's start. Someday the community will realize what it is missing by not having a technical college to attract educated workers interested in graduate studies as well as to upgrade those who can be interested in improving their lot. Perhaps some future commander will benefit from this small start.

## THE CHALLENGE OF POST MANAGEMENT

Major General  
**HARRY H. CRITZ**  
 Commanding General  
 101st Airborne Division and Fort Campbell, Kentucky

It is a distinct privilege and pleasure to address this distinguished group and to be afforded the opportunity of discussing with you the management of our fairly good size posts.

I understand that you have considered the management concepts and policies of DOD, DA, and the major subordinate commands; and that your interest at this point is the impact of the policies and concepts on installation commanders.

I'm sure that I'm not going to present any problems that will be new to you; rather, I will present the extent of the problems and how we try to solve them at my particular installation.

At Fort Campbell we have an airborne division, an engineer group of three combat battalions and five separate companies, one ordnance battalion, one transportation battalion, one quartermaster battalion, one medical battalion, and one corps artillery battalion, in addition to garrison troops.

All of these troops, with the exception of four companies, are REDCAT 1 troops and are committed to the STRAC. My chain of command is to Hq., Third Army, for all personnel, fiscal, and logistic matters; and to Hq., XVIII Airborne Corps, for all operational and training matters. (This includes operational plans.)

Thus, with this priority, we are usually in pretty good shape from the point of view of personnel and equipment.

One week ago today we started reorganizing the 101st Airborne Division from a ROTAD configuration to the new ROAD configuration.

With that as a background, I would now like to tell you who we are, what we have, and what we are doing.

All of you know that running an installation is like running a city. Our major difference: people other than the residents tell us how to run it.

And so to first things first: the location of Fort Campbell. (See Fig. 1.)

---

*Upon graduating from the U. S. Military Academy in 1935, General Critz was commissioned a second lieutenant of Field Artillery and assigned to the 1st Cavalry Division.*

*His assignment, during World War II, to the 1st Infantry Division, began an association with the "Fighting First" that was to continue with only brief interruptions beyond that war. A veteran of the North Africa landings and subsequent*

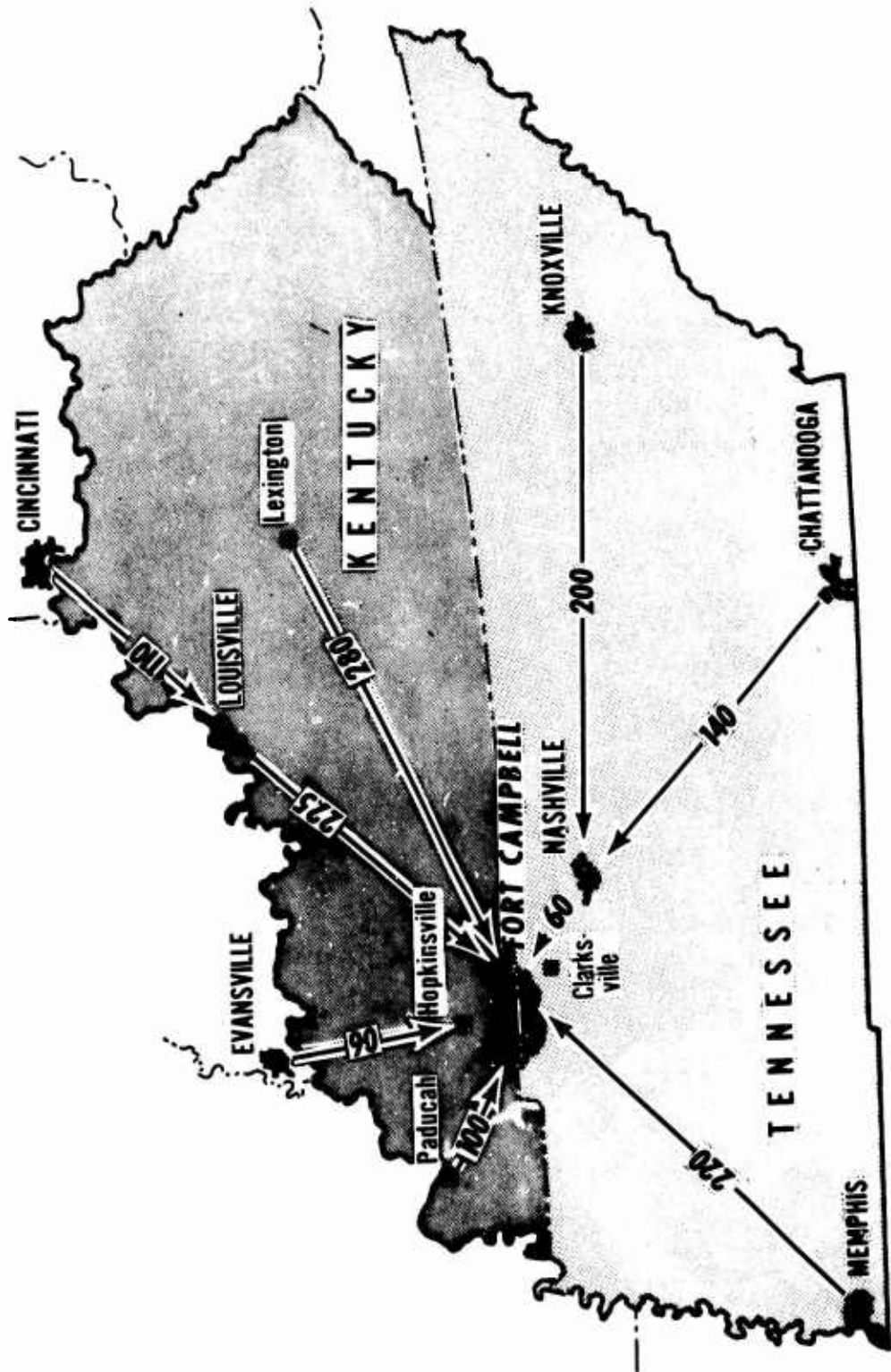

Fig. 1. Map of KENTUCKY and TENNESSEE, showing location of FORT CAMPBELL.

Outlined are the States of Tennessee and Kentucky, with the geographic location of Fort Campbell focused in relation to the major cities and communities of these states. Fort Campbell, as you can see, is located in both states (60% in Tennessee and 40% in Kentucky); it is 8 miles distant from Clarksville, Tennessee, to the south, and 15 miles distant from Hopkinsville, Kentucky, to the north. In our community relations program, a going concern considered by many as a model of its kind, the three communities of Clarksville, Hopkinsville, and Fort Campbell are frequently known as "the tri-city complex." The mileages to the other cities of the two-State area are indicated in the figure.

The Fort Campbell reservation covers an area of 105,434 acres, which is not enough. One of my major projects, now in Washington, is to procure an additional 24,000 acres.)

To the south of the main post is Clarksville Base, an agency under Sandia Base and manned by Navy and Marine personnel. Later, in a breakdown of personnel elements, I shall treat of this particular installation. Meanwhile, Clarksville Base comes under the general — and spreading — heading of Greater Fort Campbell. It is an entirely separate command, but nonetheless dependent for most post support. I might say right here that we are reimbursed for all costs arising from the Base.

Bordering the eastern side there are approximately 2,600 permanent housing units; and, to the west, permanent barracks which accommodate approximately 13,500 troops of the division, and another group which houses 1,500 engineers. Other permanent structures include two chapels, two theaters, warehouses, and a Signal center. The remainder of the post buildings are temporary, World War II type.

Fort Campbell, 22 years old next September, is still expanding. Many of the frame structures erected in the early days of World War II remain, and presently house about 6,000 men. In point of

---

*operations, he served in a variety of staff assignments and with the Division's 32d FA Battalion.*

*He returned to the U. S. in 1948 after service as Executive Officer and Commander of the Division Artillery. He also served as Secretary of the General Staff, Third Army; and in the same capacity with U. S. Forces, Austria. In the U. S. he was assigned to the Artillery School, Fort Sill, Oklahoma, where he was later named Secretary. He then served as instructor and secretary at the Army War College.*

*Following a tour of duty as G1 at Sixth Army, he was named Assistant Artillery Commander of the I Corps in Korea, remaining there as G1 with the Eighth Army.*

*Returning to the U. S., he was assigned to the Pentagon with the Office of the Assistant Secretary of Defense for International Affairs. Next came his initial tour of airborne duty. He served as Chief of Staff, 101st Airborne Division and Fort Campbell, Kentucky, and as commander of the Division's 1st Airborne Battle Group, 506th Infantry.*

*He then returned to Europe for duty as Special Assistant to the Supreme Allied Commander, SHAPE; and as Commander of the VII Corps Artillery in Germany.*

*General Critz assumed command of the 101st Airborne Division and Fort Campbell in February 1963.*

*(The present paper was prepared from the transcription of an oral presentation made at USAMS, Fort Belvoir, Virginia, on 8 February 1964.)*

### PRINCIPAL

- To close with the enemy and destroy or capture him
- By airborne assault to seize and hold important objectives until ground linkup can be accomplished or until reinforced by air or surface landing.
- Execution of small-scale airborne commando-type operations to perform selected missions.
- On short notice to move to any overseas land area as a deterrent or resistance force in any threatened area.

### SECONDARY

- The maximum service and support to Army troops and their dependents.

Fig. 2. Principal and secondary missions of 101st Airborne Div.

101st AIRBORNE DIV.	13,649
NON-DIVISIONAL UNITS	6,967
CONUS OPERATING UNITS	1,045
NAVY	305
MARINE	234
AIR FORCE	185
CIVIL SERVICE EMPLOYEES	1,704
CONTRACT PERSONNEL	505
NONAPPROPRIATED FUND PERSONNEL	214
DEPENDENTS & OTHER PERSONNEL	<u>9,996</u>
	33,759

Fig. 3. Population of Fort Campbell and Clarksville Base.

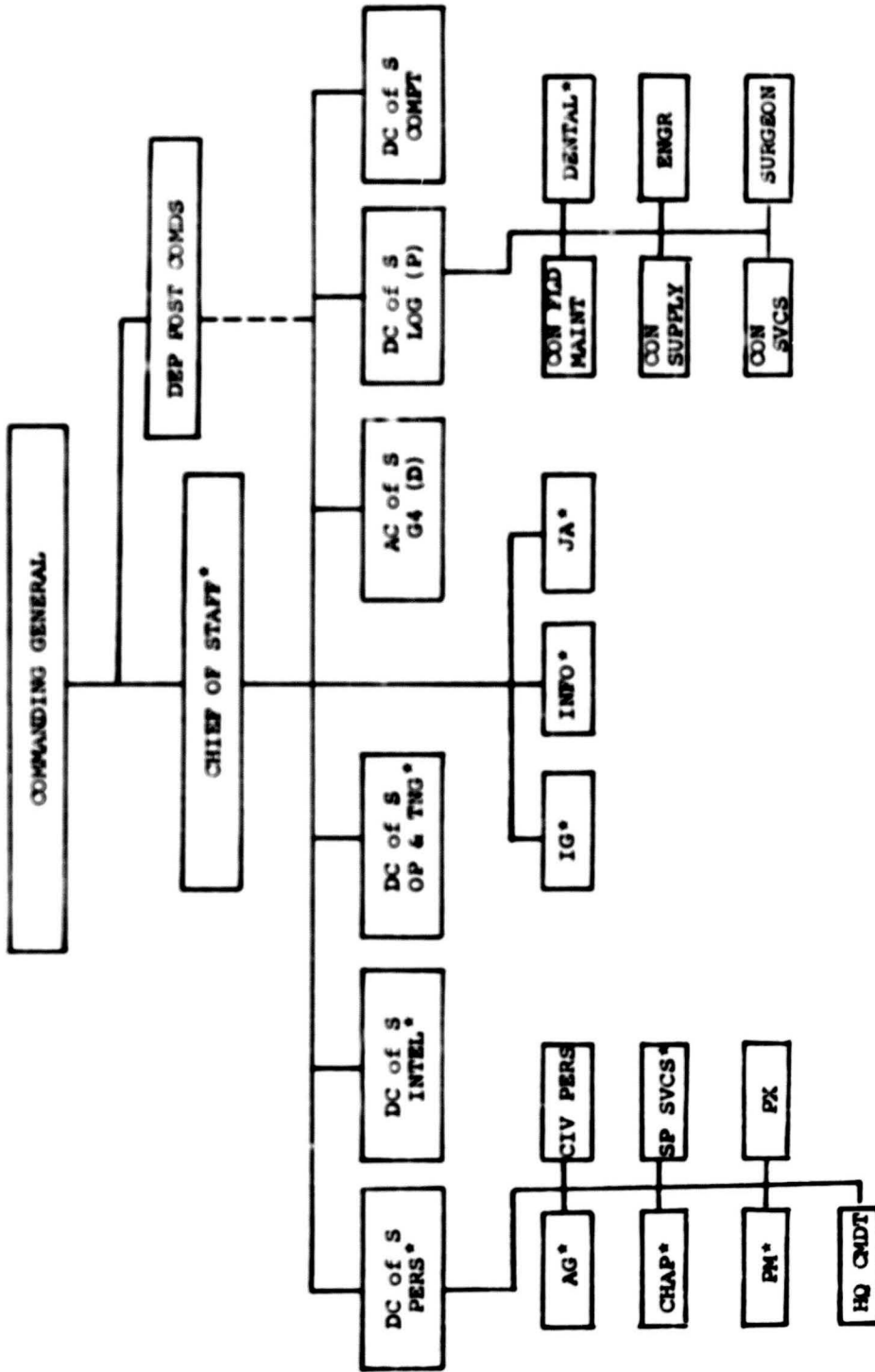

Fig. 4. Fort Campbell overall command structure.

fact, our headquarters building, refurnished many, many times, is of World War II vintage. Almost to a plank, these buildings are in a state of disrepair, and this has long been a problem to commanders. For with limited funds, the deferred maintenance of these buildings continues to mount.

North of the post proper is Campbell Army Airfield, a Class A installation which is in full operational status 24 hours a day. It is considered the largest Army airfield in the world, covering 3,382 acres and boasting a main runway of 11,800 feet.

During calendar year 1963 there were 59,137 landings and take-offs, 37,579 of which were by Air Force transport aircraft committed in the training and operations of the 101st Airborne Division.

At Campbell Army Airfield, the maintenance of grounds, runways, and buildings; the operation of mess facilities, transportation, and billeting for transient and tenant units — all are the responsibility of Fort Campbell. Army personnel at the airfield are augmented by Air Force personnel who operate the crash fire station, the POL (Petroleum, Oil, and Lubricants) section, control tower, radar, and navigational facilities. The Air Force units are under the operational control of Army personnel.

First, I will mention the Division mission, for it is from this that the secondary mission of service and support begins. (See Fig. 2.)

To fully appreciate and understand the secondary mission you must have an awareness of the number and types of personnel involved. Fig. 3 illustrates this.

It is of particular interest that all branches of the Service are included (or represented) in the population of Fort Campbell. Division personnel compose a little more than one half the total population. CONUS operating units at Fort Campbell include Table of Distribution, U. S. Army Hospital, 553d MP Co., and 510th CI personnel. The total population of 33,804 is larger than either neighboring Clarksville, Tennessee, or Hopkinsville, Kentucky.

Now, for my managerial responsibilities for Fort Campbell. The structure of organization, then, must provide for channeling and coordinating the results of the deliberations of all of its parts in such a way that decisions are expedited. To be most effective, decisions must be made as close as possible to the point of action. This necessitates a more carefully centralized control over decentralized operations. Thus we are continually striving to improve our organizational and administrative processes.

Now let's first look at our overall command structure. (See Fig. 4.)

At Fort Campbell, I operate an integrated headquarters. The blocks with no asterisks denote members of my staff who have a direct responsibility for Post operations. Other members of my

	MILITARY	CIV	TOTAL
RECOG REQMTS	1,446	1,734	3,180
AUTHORIZATION	1,307	1,599	2,906
SHORTAGE	139	135	274

Fig. 5. CONUS operating spaces, 28 Feb. 1963.

	MILITARY	CIV	TOTAL
RECOG REQMTS	1,443	1,770	3,213
AUTHORIZATION	1,045	1,540	2,585
SHORTAGE	398	230	628

Fig. 6. COMUS operating spaces, 31 Dec. 1963.

staff who have a responsibility for Division and Post operations are indicated by asterisks.

With this organization, we not only save spaces which would be required to operate separate headquarters but we have a smoother functioning organization, because my combined staff is thoroughly familiar with problems in both the tactical and support areas. Should the Division leave, there are personnel within each staff section who would remain and continue the post function.

The major challenges of management operations today are in three main areas: *personnel*, *logistics*, and *budget*; and I shall consider them in that order.

*Personnel.* The problem of personnel shortages for the support mission is critical in both civilian and military categories. (See Fig. 5.)

On 28 February 1963, when I assumed command, Fort Campbell was short 274 spaces of the requirement recognized by higher headquarters.

This problem continues to worsen: See Fig. 6.

On 31 December 1963 there were 354 personnel less than that authorized for the previous year, a total shortage of 628 from the requirement recognized by Hq., Third U. S. Army and CONARC.

The reduction of civilian spaces is of particular importance for two primary reasons: 1) Shortage of civilian spaces interferes with my combat mission, since it becomes necessary to use an excessive number of military personnel in support activities; 2) civilian reductions in force create internal turbulence.

In order to meet the shortage of spaces, we have been forced to use our combat units on a rotating basis to furnish post support, and we do a great deal by contract.

We also utilize our combat support units for post support in areas that coincide with their combat support mission. I will explain this in detail when I talk about logistical problems.

I mentioned earlier the particular importance of the internal turbulence created by a civilian reduction in force. Recently we had a RIF action which necessitated the separation of 32 civilian employees. In order to separate these 32 employees, it was necessary to give a total of 202 RIF notices with a total of 108 reassignments. Of these 108 reassignments, 62 required demotions. This not only has an adverse effect on the operation, it also has a serious and adverse effect on morale.

*Logistics.* The second area is that of logistics. My Post G4, or Director of Logistics, is the backbone of post support mission. (See Fig. 7.)

You will note that technical services, as such, no longer exist. The consolidation of Field Maintenance, Supply, and Services activities has been quite interesting.

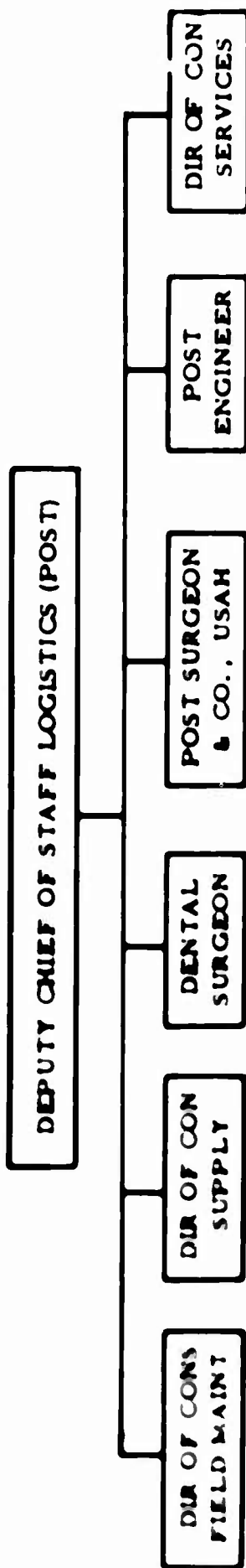
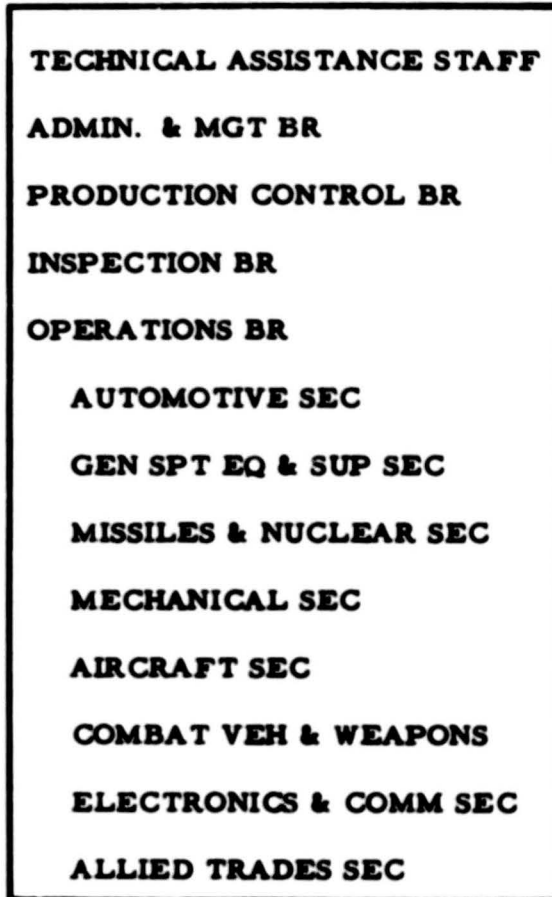

Fig. 7. Organization charts Oic.. Deputy Chief of Staff, Logistics (Post).



**Fig. 8. Directorate of Consolidated Fld. Maintenance.**

Let us first examine the Consolidated Field Maintenance activity which we started last June. (See Fig. 8.)

You will note that the Operations Branch is divided into commodity groupings as established by the DA in AR 750-7. These commodity groupings were established after intensive study to determine the areas where consolidation would be most effective.

Fort Campbell, like most Army installations, has maintenance facilities spread over a wide area, with distances between the shops ranging from 1 $\frac{1}{2}$  to 5 miles. To physically consolidate these shops for maximum efficiency and effectiveness requires facilities which are nonexistent at this time. Inadequate facilities make the job of consolidation more difficult, of course.

We have consolidated all maintenance management and shifted repair responsibility to shops best suited for each type of equipment. For example, we have consolidated into one shop all woodworking which was formerly accomplished in three shops by the Quartermaster, Engineer, and Ordnance sections. Heavy canvas repair by Quartermaster has been combined with automotive canvas to provide better, faster service.

As of now, we have centralized the repair of 15 different types of equipment. Continuing study will disclose additional areas where centralization can be effected within existing facilities.

The equipment densities supported in this field maintenance activity number 2,420,000 items ranging from canteens to bulldozers. In this organizational element, the "growing pains" of consolidation are still growing by the addition of The Army Equipment Records System (TAERS).

Next we'll examine Consolidated Supply, which includes all supply activities, except Medical and Engineer R&U. (See Fig. 9.) This was also organized last June.

We continue re-warehousing to consolidate supplies, thus making for better control and more expeditious service to our troops.

Consolidated Supply knows the same problem as does the Maintenance activity: a shortage of trained supply personnel, inflexible civilian personnel regulations, and delayed action from supply depots. These problems, together with the mechanization of item accounting, require time — and patience as well.

The third member of this group is the Director of Services. (See Fig. 10.) This was last and started in November.

This organizational element includes the consolidation of Signal, Quartermaster, and Transportation after Maintenance and Supply have been removed. In addition, we include Self-Service Supply and Clothing Sales, which were formerly components of the G4 office.

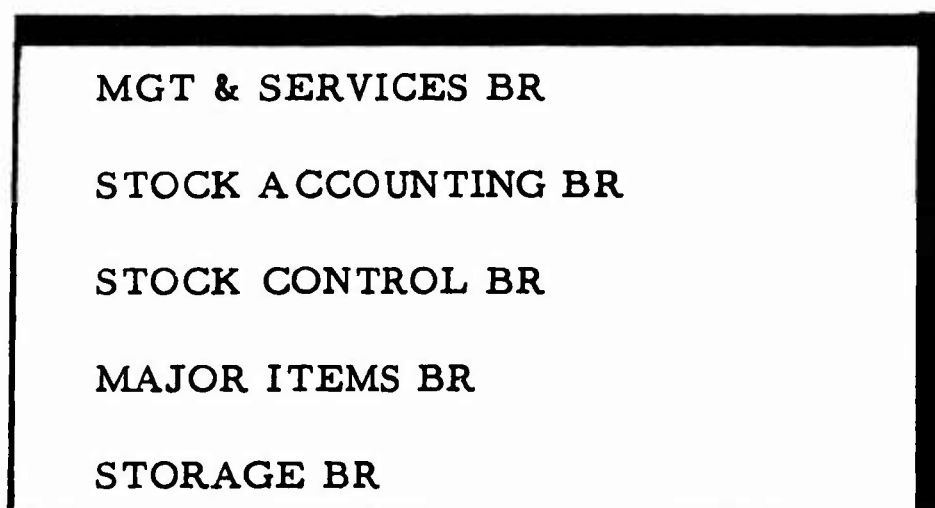

Fig. 9. Directorate of Consolidated Supply.

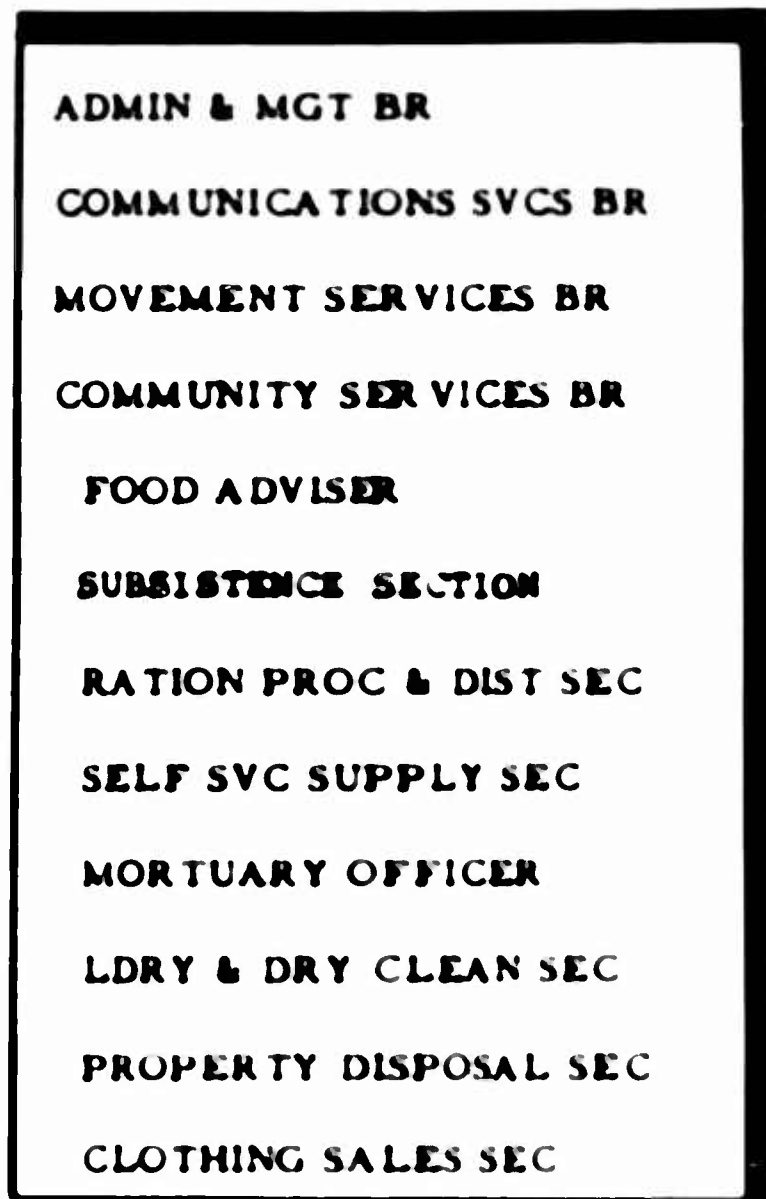

Fig. 10. Directorate of Consolidated Services.

Most of my problems in the area of logistics could be easily solved if I had no problems in the areas of personnel, as we have seen, and of the Budget, as you shall hear.

The reporting workload always seems to be inordinately heavy in the area of logistics. We have 147 weekly or monthly reports, with 233 feeder reports on a recurring basis, totaling approximately 5,000 annual reports, which require some 19 man-years to prepare. Many of these reports are required on a crash basis, which in itself disrupts normal operations.

To overcome, or alleviate, some of the problem areas, I employ troop units with support missions to assist with related Post missions. For example:

The quartermaster battalion mans the Central Issue Point and assists in the laundry, meat plant, and bakery operations.

The 46th Engineer Detachment (Utility) is in direct support of the Post Engineer for specified maintenance projects.

Other Engineer units assist in road building and maintenance and bridge construction as troop projects which are compatible with their combat mission.

We also contract many projects, such as coal hauling; garbage and trash; quarters' painting; janitorial (Hq.), etc.

My management improvement and work simplification programs are particularly applicable to the logistics area. For instance, for FY 1963, improvements in methods of operation resulted in benefits of \$550,000 to the installation. This emphasis toward reduction in operational cost and increase in personnel efficiency is continuing in the present fiscal year under USCONARC Project TRIM.

Our conversion of coal-fired to gas-fired furnaces in the permanent buildings has decreased our labor requirements. And our self-help program provides another means of operating with reduced funds and personnel.

*Budget.* The third and last problem area I will discuss here is that of my budget. Before I talk about the budget and its attendant ills, I would like to refer you to Fig. 11, which shows my recent reorganization for the Deputy Chief of Staff, Comptroller, approved on 20 December 1963.

In the field of financial management the Comptroller can be a valuable member of a commander's staff, and I believe our Comptroller organization to be highly effective, as reorganized. You will notice that it differs from the conventional Comptroller organization in that Data Processing and Finance and Accounting are divisions of the Comptroller Section.

Increased command emphasis, at all levels, on the mechanization of business-type or administrative data-processing operations makes it imperative that the system be responsive to the commander's total

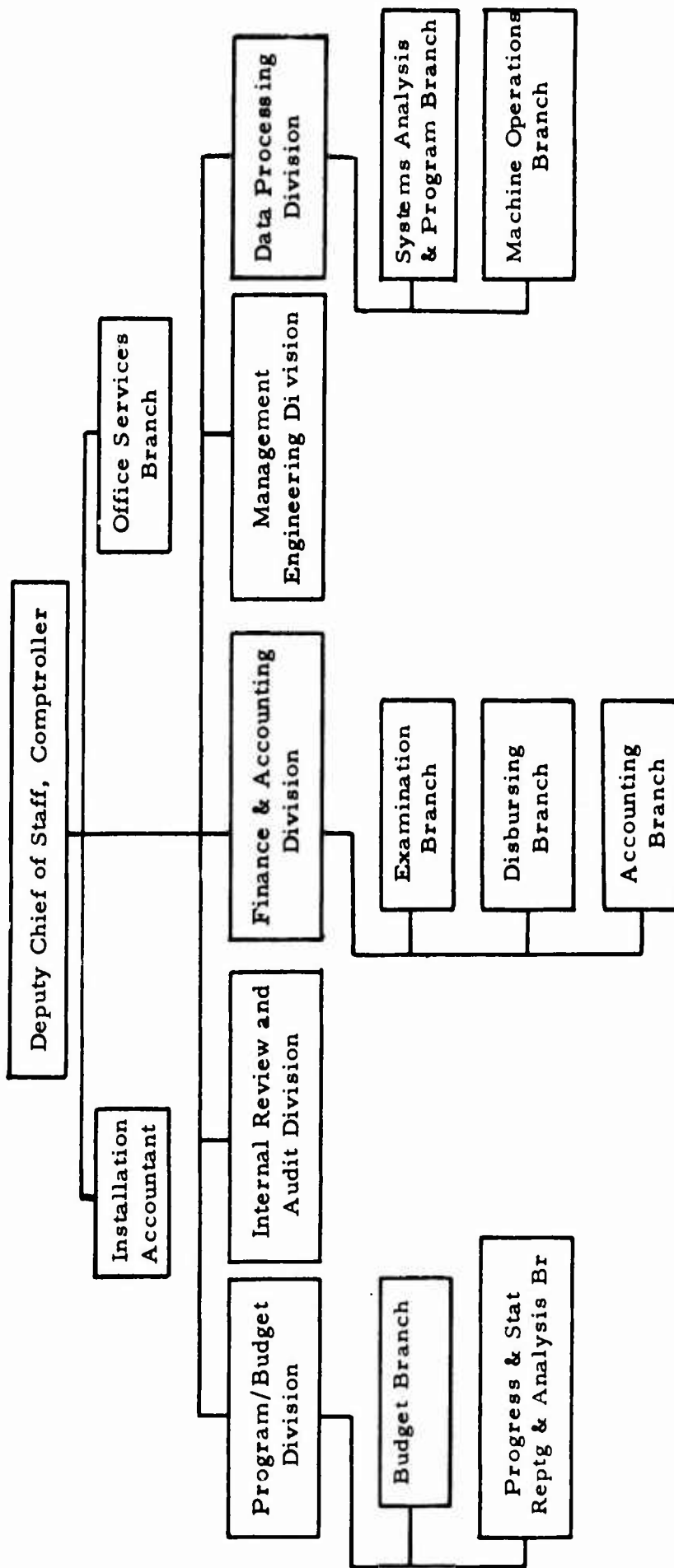

Fig. 11. Office, Deputy Chief of Staff, Comptroller.

requirements. In the past, data processing has been primarily in the field of financial management. But with the mechanization of Supply and Maintenance, it is necessary now to operate this activity on a wider scope: a service center concept. The operation of this activity by the Comptroller should provide a machine system which will react rapidly to total accounting and reporting requirements.

Finance and Accounting has been consolidated into the Comptroller Section, and I believe this will result in the following advantages:

—Increased flexibility and better work performance with a progressively smaller workforce;

—A more closely-knit organization, with all personnel working as a team to insure the best financial and accounting management for the command.

—The providing of a training opportunity for additional personnel in Comptroller functions — a career bonus, actually.

—Centralized responsibility for all elements of financial management.

And, now, budgetary problems:

The apparent existence of voids in the communications channel is a problem. For example: The original dollar guidance for FY 64 for Engineer R & U was \$3,500,000, whereas the actual requirements for pay of authorized civilian workers and fixed costs (fuel, electricity, etc.) were \$5,100,000. The original shortage of \$1,600,000 has now been reduced to \$500,000 as additional funds were authorized. This current shortage was presented to higher headquarters in our mid-year review as an unfinanced requirement.

The growing demand for more detailed data and justification at higher levels is another problem.

Although studies have been made with the planned objective of reducing the number of detailed cost accounts, no significant progress has been made. We believe that significant reductions should be possible in detailed accounts for Military Family Housing and Engineer R & U Services.

Military personnel are diverted from training to accomplish support missions formerly performed by civilian personnel. Training suffers thereby, as does the support job.

Delayed guidance and short deadlines result in crash analyses, cursory review of accumulated data, and inadequate time for coordination and command participation in the quarterly funding reviews. The current three-month cycle does not provide — does not allow — time for DA action to reach installation level. Therefore the next reporting cycle is initiated without this guidance.

The late receipt of funding guidance necessitates major changes in programing actions at station level. What's more, it also changes

the priority of unfinanced requirements before the reporting cycle is complete. An example known to many is the Cuban crisis in FY 64; another, ROAD in FY 64.

We have recommended to Third Army that the budget review cycle be changed from the traditional quarterly dates, 30 September, 31 December, 31 March, and 30 June, to tri-annually: 31 October, 28 February, and 30 June. This departure would not only reduce the workload by eliminating one of the annual reviews, but it would also provide additional reporting time. This is sorely needed.

It would also enable the station to obtain and reflect DA guidance before beginning a new reporting cycle, thereby improving the quality of these reports.

Although I have not presented a particularly rosy picture for the fiscal year which ended 30 June 1963, Fort Campbell did meet all budgetary deadlines and had a consumer fund utilization of 99.96%, thus exceeding the CONARC goal of 99.9%.

Now, I would like to discuss briefly the money we have to run the Post for FY 64 and how we plan to spend it.

My funded cost ceiling for the OMA appropriation is \$24 million plus approximately \$2 million for Military Family Housing. My unfinanced requirements, which, as you gentlemen know, are funds that I need but do not have, are approximately \$1,500,000 or 6%. To go down the line on shortages: I am short almost \$600,000 in my Operating Forces funds; my Medical-Dental requirements are \$175,000, and the next major amount is approximately \$490,000 for Engineer R & U. In Logistic Services we originally had a \$70,000 shortage, but higher headquarters made an unforeseen withdrawal of \$135,000; therefore \$205,000 is short at this time. We are in good shape on Military Family Housing money.

There has been a continuing trend to limit and restrict the commander's flexibility in the use of funds authorized. For example, my authority to transfer funds between the major budget accounts is limited to 1% of the amount authorized, or \$50,000, whichever is lesser. In other areas, such as Engineer R & U Services, we have a ceiling of \$5,255,000; but, at the same time, we are advised that we must spend \$2,500,000 for maintenance and repair of fixed property and also must procure \$246,000 of new heavy equipment. This leaves \$2,509,000, which is inadequate to pay civilian employees, utilities' bills, and other fixed services. It was necessary to secure authority to transfer \$210,000 from P2000, Operating Forces, to 9030, Engineer R & U Services, in order to get through the third quarter. Unless additional funds are provided by higher headquarters, I will have to 1) defer the procurement of the \$246,000 programed for Engineer R & U equipment, and 2) request authority to transfer approximately \$250,000 more for fourth quarter requirements.

Although I have no magic solution for these problems, I feel that the following points are worth considering:

*Keep on top of your funding with a continuing analysis of the situation. Don't wait until higher headquarters' directives are received.*

*Present a convincing story to higher headquarters with facts, figures, and meaningful language.*

*Make a careful diagnosis of your basic assumptions.*

*Reprogram as necessary, but determine what programs will have to give if additional funds are not forthcoming.*

*Encourage close coordination of resource problems with your Comptroller before-the-fact to hold money flaps to the minimum.*

In summary, we need to emphasize for our own self-interest an increase in managerial capacity. This capacity includes not only the ability to achieve results through people but the ability to accept or place a premium on new ideas. I am not suggesting that we undermine compliance with policy or regulations, but I feel that we need to constantly seek opportunity for the individual to improve the area of his assigned work.

In the State of the Union Message delivered by the last President Kennedy, he said, "Let it be clear that this Administration recognizes the value of dissent and daring, and that we greet healthy controversy as the hallmark of healthy change."

I feel that we now have a clear indication of the intent of the present Administration: that new ideas are to be nurtured rather than stamped out, experimentation is to be encouraged rather than put aside, new pilot plans are to be formulated rather than put into the discard. It is out of this kind of thinking that we can produce some of the creative solutions. And we will never run out of the need for solving problems regardless of the magnitude of those problems. We will never reach the point where we are totally satisfied with the manner in which a particular function is being performed. Let us encourage the development of views that lead to innovation even if those views, at the initial presentation, are a bit disturbing. It is the optimum solution that we should be seeking at all times.

## OPERATIONS OF THE SUPPLY AND MAINTENANCE COMMAND

Major General  
ROBERT C. KYSER  
Deputy Commanding General  
U. S. Army Supply and Maintenance Command

When I was graciously invited to speak on "Operations of the Supply and Maintenance Command," I readily accepted for two reasons. First, we in SMC believe we have some management problems and a management approach worth talking about. Second, it is disconcerting to know that there are many who aren't yet acquainted with SMC's role in the Army.

I will strive to answer these questions during my presentation: How do we manage SMC? What is our relationship with the Army Materiel Command? What is our relationship with the Defense Supply Agency? And, finally, what are our views on the flexibility provided under the current organizational structure?

Briefly stated, SMC has the job of managing the Army's supply distribution system. Before proceeding too far, let's review the planning phase of Project 80, Reorganization of the Army, and look at the original thinking from which our present organization evolved. At the time of the reorganization, there was the common view among logisticians that the existing organization was not sufficiently oriented toward the customer. Also, the opinion was prevalent that there was too much of a break between the concept stage in the development of an item of materiel and the final procurement and distribution of the item.

Hence in the organization of the Army Materiel Command, as originally conceived, there were commodity commands which were industry-oriented and the Supply and Maintenance Command which was user-oriented. The Test and Evaluation Command was also user-oriented, conducting the tests necessary to insure that items produced met user requirements. The makeup of the organization in the planning stage has undergone some changes, and we will look at the current organization shortly.

---

*General Kyser first served in the Infantry upon graduation from West Point in 1934. During assignment to Office of the Quartermaster General in 1941-44 he designed the War Department shipping-document system of supply documentation, used world-wide until 1962. In World War II he served on the staffs of General Bradley and Field Marshal Montgomery, assisting in plans for the Normandy invasion, and, later, in operations in Central Europe.*

Before leaving this topic, however, note the Supply and Maintenance and transportation elements. As opposed to the research and development and procurement and production functions, only one command, SMC, has the supply, maintenance, and transportation functions. Therefore, to avoid duplication of operation, and since both headquarters were to be in Washington, the supply, maintenance, and transportation elements of AMC Headquarters were eliminated and SMC was given AMC-wide responsibility for these functions. Needless to say, a considerable personnel savings is being realized from this arrangement.

In the current AMC Headquarters organization, we attach importance to the relative position of the various elements of the coordinating and supporting staffs. In that each of the five commodity commands have R & D and procurement and production functions. AMC Headquarters has directorates to coordinate these functions. As I stated, there are no supply, maintenance, and transportation staff elements in AMC Headquarters.

To give you a better understanding of General Schomburg's AMC-wide responsibilities, I want to spend a few moments describing the financial management aspect of the setup. We might call this schematic the AMC programming staff although there is no such thing officially. We are talking about the O&MA appropriation. The AMC staff manages programs amounting to about 40%, in dollar volume, of the AMC operating program. The remaining 60%, or the supply, maintenance, and transportation activities, are directed by the Commanding General, SMC. In addition, he executes, as a command function, certain programs under staff supervision of the AMC staff.

#### SMC PROGRAMING RESPONSIBILITY

Figure 1 portrays the magnitude of the AMC and SMC operating programs expressed in dollars, and the relationship between these two programs. The bar on the left amounting to one billion dollars represents the AMC O&MA operating program. This program is executed by all the major subordinate commands within AMC. Now, of the AMC program of one billion dollars, the CG, SMC, manages or directs 602 million dollars' worth, or 60.2%, of the AMC operating

*He has held staff assignments in DA and DOD. Among his assignments during the last several years have been Deputy G4, USAREUR; commander of a Quartermaster depot in Germany; duty in the Office of the Quartermaster General; commander of the New Cumberland General Depot; Quartermaster, Communication Zone, Europe; commander of Atlanta General Depot.*

*In August 1962, General Kyser was appointed Deputy Commanding General, U. S. Army Supply and Maintenance Command.*

*(The present paper was presented at USAMS, Fort Belvoir, Virginia, on 1 October 1963).*

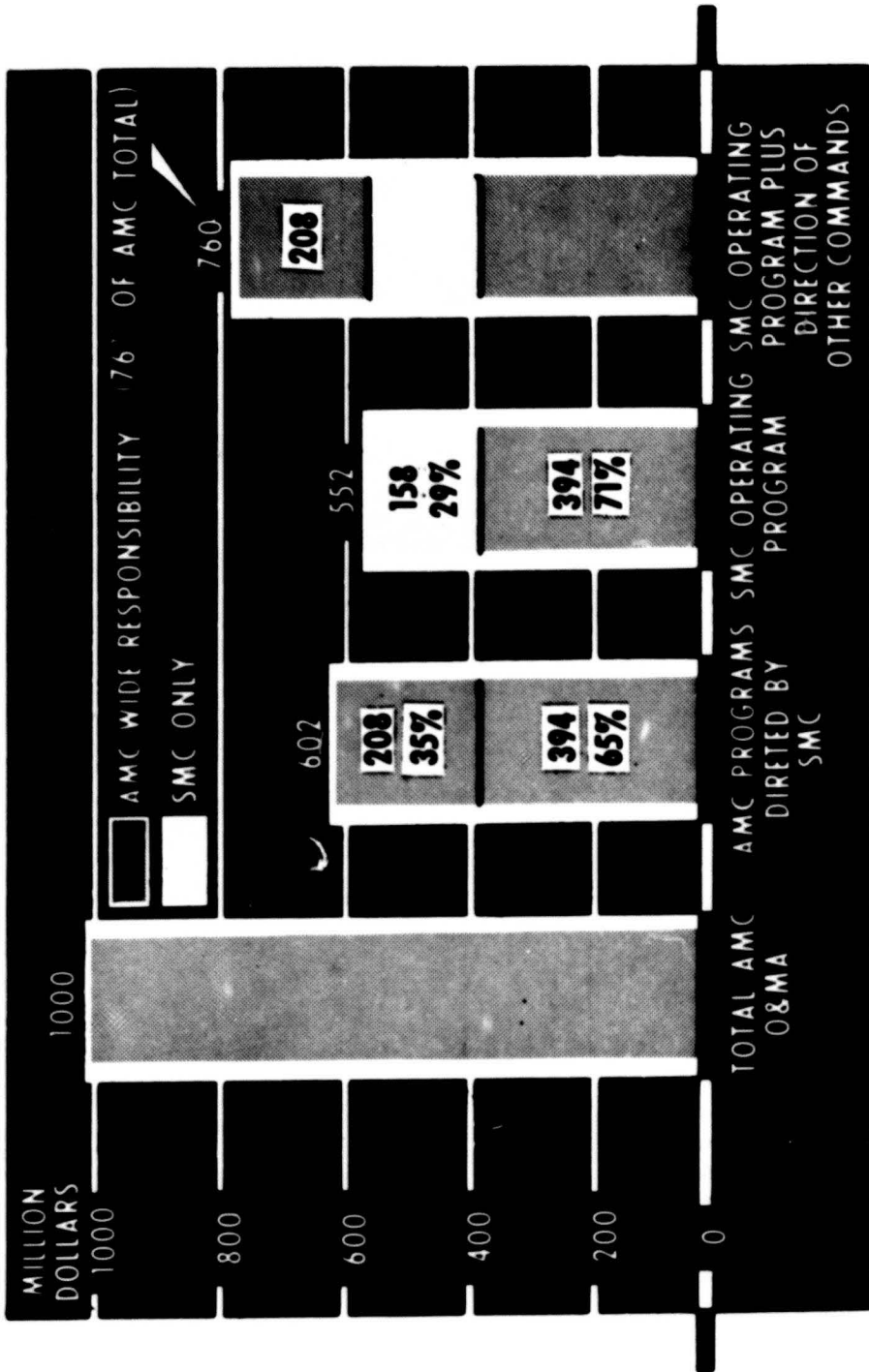

Fig. 1. SMC programming responsibility (O&MA, FY 63).

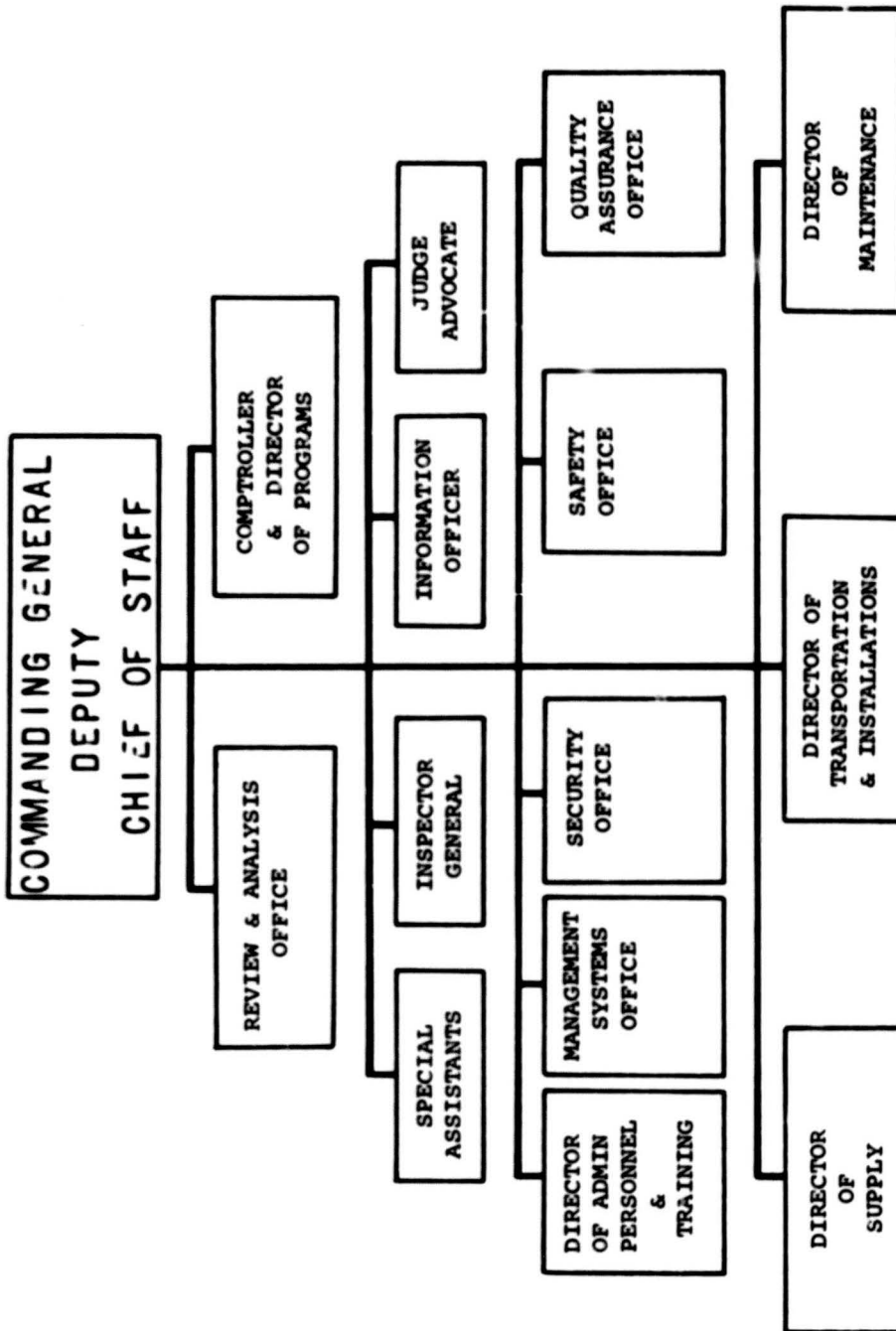

Fig. 2. SMC organization chart.

program. The Supply, Transportation, and Maintenance activities which the CG, SMC, directs on an AMC-wide basis are executed to the extent of 394 million dollars within SMC proper. The balance, or 208 million dollars, is executed by the other major subordinate commands under the supervision of the CG, SMC. On a command basis, SMC proper has an operating program of 552 million dollars. Note the third bar. Of this program, 394 million dollars' worth represents activities also directed by the CG, SMC, on an AMC-wide basis. Nearly all the remaining 158 million dollars represents the SMC O&MA of the facilities program directed on an AMC-wide basis by operating directorates in AMC proper. The fourth bar on the right represents the total programming responsibilities of the CG, SMC. As a commander, he executes a program of 552 million dollars; and in addition, he directs program activities of other major subordinate commands to the extent of 208 million dollars, representing a total of 760 million dollars or 76% of the total AMC operating program.

Now let's proceed with a look at the AMC subordinate command structure. Modification of the AMC subordinate command organizational concept, which I discussed earlier, has resulted in a different structure. The commodity commands are aligned in accordance with the Army's traditional requirements "to move, shoot, and communicate."

#### SMC ORGANIZATION

Let's take a look at the SMC Headquarters organization, the tool by which we manage our widespread command, which currently employs some 59,000 civilians and 2,800 military personnel at some 67 installations spread throughout the U. S. from Massachusetts to California. (See Fig. 2.)

This is our current organization. The supporting staff is shown in the middle three tiers in the figure, and I think their functions are self-explanatory. The functional staff or mission directorates are shown on the bottom tier, and it is in these three directorates that the bulk of the personnel strength is located. Our Headquarters strength approximates 75 officers and 850 civilians. It should be pointed out that this represents roughly a 50% reduction in the manpower required by the former Technical Services to do the same job.

Before discussing the SMC subordinate command structure as it now exists, I would like to go back once more, for comparison purposes, to the concept from which the structure stems.

It was envisioned that there would be seven multi-mission depot complexes of three to five depots each, geographically grouped, with

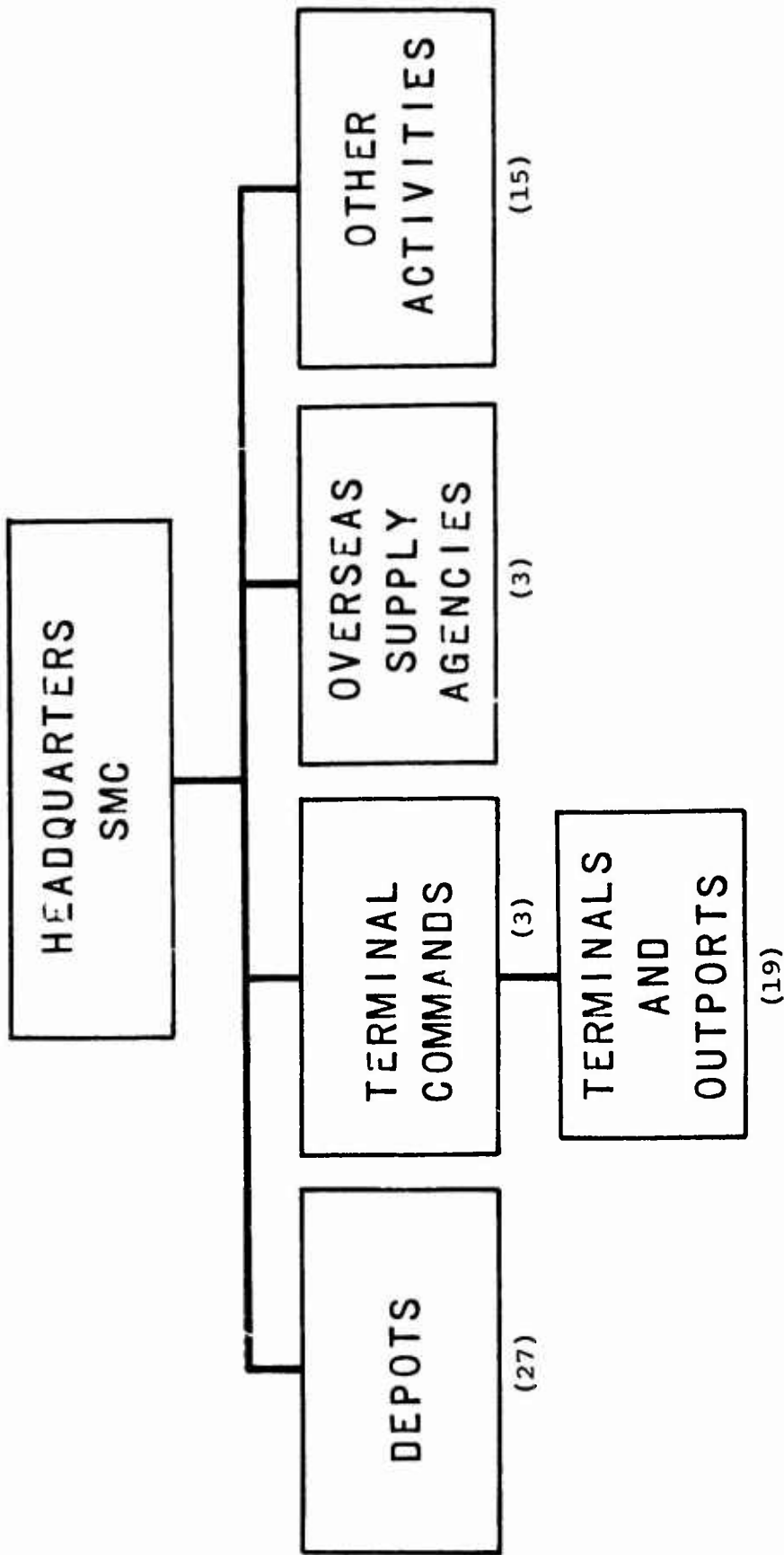

Fig. 3. SMC subordinate installations and activities.

only one depot in each complex reporting directly to SMC Headquarters. It was also planned that five of the ammunition depots would be subordinate to five other ammunition depots in their respective geographic areas. In addition, the oversea supply agencies were to report to the terminal commands in their vicinity. None of these plans to reduce span of control materialized. As a result, all the depots and the oversea supply agencies ended up reporting directly to SMC Headquarters. Subsequent to the reorganization, some depots were closed and others were transferred to DSA.

#### SMC SUBORDINATE COMMAND ORGANIZATION

As shown in Fig. 3, 27 depots, 3 terminal commands, 3 oversea supply agencies, and 15 other activities, including the Army Maintenance Board and the Army Petroleum Center — 48 installations and activities in all — report directly to SMC Headquarters in Washington. By comparison, 27 commanders report directly to the Chief of Staff of the Army.

#### SPAN OF CONTROL

Obviously, span of control represents one of our most challenging management problems, and I want to tell you what we did and are doing to solve it. On 1 August 1962 we inherited 33 depots, 19 port terminals, 33 depot procurement offices, 3 terminal procurement offices, 34 depot maintenance shops, and 42 finance and accounting offices, many of which were reporting directly to the technical services. Our first move was to abolish Class II status everywhere, and this immediately reduced the span of control. Our next move was to determine what to do with all the miscellaneous activities, so we initiated what is commonly called our "bits and pieces study." We have already eliminated 25% of the miscellaneous activities by combining similar functions, regrouping others, or getting rid of the responsibility altogether. For example, we combined the field packaging activities inherited from the various technical services. These have been centralized in the packaging and storage center at Tobyhanna Army Depot in Pennsylvania. During this fiscal year we plan to reduce the miscellaneous activities by another 25%.

As you may have surmised, we inherited several different supply systems from the Technical Services. It became our immediate requirement to develop a single, uniform system. And so we launched a study called TASAMS, which stands for The Army Supply and Maintenance System. The study group was faced with the task of determining how many depots we would need, which depots should be retained, what maintenance activities should be retained (and

where), and what type requisition processing system should the Army have. Should we have a centralized system as the Transportation Corps had, decentralized as the Ordnance Corps had, or something in between like the Quartermaster Corps had? The study has been underway for almost a year and approval should be forthcoming soon. Implementation of the major portion of the plan will be accomplished within two years.

Concurrent with the TASAMS study, we have been engaged in a major project called SPEED, that is, System-Wide Project for Electronic Equipment at Depots. The purpose of SPEED is to provide a standardized, mechanized, and integrated supply and maintenance system within our depots. Standard automatic data-processing equipment is being installed in our larger depots. We are, therefore, able, at a central point, to program supply, personnel, and other procedures for use on this equipment. Not only does centralized programming insure standardization, but also economizes significantly on the manpower involved in the programming effort.

To bring about consistence in terminology and to identify the various depot functions, we have prescribed a standard depot organization to be used SMC-wide. We have also published, or will publish during this fiscal year, regulations standardizing physical inventory and stock control procedures. To summarize our objective in the vernacular, we intend to operate from the same sheet of music throughout SMC in all facets of the operation.

One major effort we have going in the transportation area of responsibility is SUNSPOT, which is Study of Unitization Systems, Policies, and Techniques. The objective is to update the Army's unitization policies and procedures to make them compatible with the current state of the art, thus contributing to the overall development of a supply distribution system responsive to the customer under both peacetime and mobilization conditions.

At the time SMC Headquarters was established, our field installations and activities were preparing over 1,400 reports. Through systematic review by a special task group, we have eliminated almost 900 reports. Revamping of our reporting system has enabled us to start on the next step, the development of a modern management information collection and reporting system.

#### SMC INFORMATION SYSTEM

The system, as pictured in Fig. 4, provides central locations to which source data can be fed from national inventory control points, depots, ports, oversea supply agencies, maintenance activities, and CONUS and oversea commands. The raw source data are collated, analyzed and stored at the three central locations, Letterkenny,

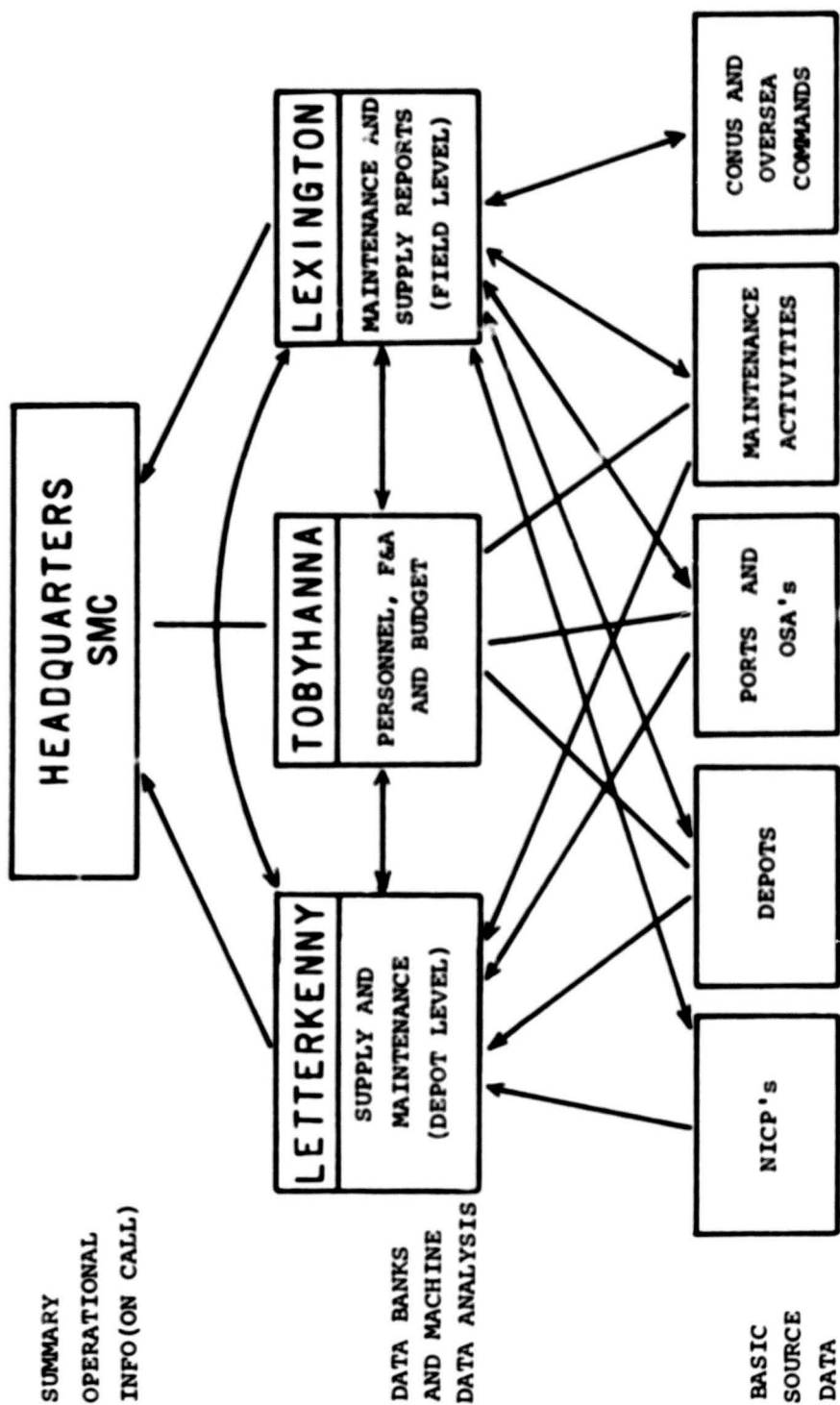

Fig. 4. SMC information flow (via transceiver network).

Tobyhanna, and Lexington Army Depots. At Letterkenny, we have concentrated the information necessary in working with depot systems. For example, the Depot Maintenance Control Center was activated there to provide centralized operational control over depot maintenance programing, scheduling, and reporting. At Tobyhanna we have centralized matters pertaining to personnel, finance and accounting, and the budget. We have activated the central Finance and Accounting Field Office here. At Lexington we have centralized field reporting for supply and maintenance information. We have established an organization here called the Logistics Data Center. It is field-oriented in its objectives, as opposed to the depot-oriented activities at Letterkenny. Of course we will use ADP equipment and transceivers to the maximum extent possible in this operation. Our Headquarters is scheduled to move into a new office building in December, at which time we will have high-speed printers and transceivers installed to rapidly obtain the information required from the three central locations. We feel that this system will save a considerable amount of pencil pushing at the Washington level, and at the same time provide up-dated information as required.

I mentioned that the Depot Maintenance Control Center will provide centralized operational control over depot maintenance programing, scheduling, and reporting. We might go into some before-and-after aspects as to what will be achieved when this activity becomes fully operational.

A multiplicity of contracts and complex coordinating effort was required to effect the total program when the Depot Maintenance Control Center was established.

When the Center becomes fully operational at the end of FY 64, it will receive requirements from the commodity commands' and other agencies' maintenance managers and schedule workload into the shops based on capacity, funds available, and other factors. Obviously the overall depot maintenance program will be greatly simplified.

#### SMC AND DSA RELATIONS

I would like to proceed to my next requirement, that is, to discuss SMC's relationship with the Defense Supply Agency. The commodities managed by DSA are essentially those supplies common to two or more of the military services, and are generally commercial-type items. No major items of equipment are involved. DSA stocks are maintained in depots managed by DSA and in other depots still managed by the military services.

The Commanding General, SMC, has been assigned the primary role in maintaining Army relationships with DSA. We are involved almost daily with DSA in such matters as negotiations on transfer

of item management, reviewing DSA supply procedures to assure that they are completely responsive to Army needs, and developing or executing inter-Service support agreements.

This matter of Service agreements is a particularly critical one with Army and DSA for several reasons. In the first place, we have turned over four depots to DSA — Philadelphia, Richmond, Columbus, and the Tracy Depot — for complete management and control. At each of these places, however, there are residual Army functions still to be performed. At all four locations, the Army is required, under law, to own and manage the real property even though we have issued a permit authorizing DSA to operate the depots themselves. Secondly, DSA continues to store, and will for some time, a large part of its stocks in SMC depots. Finally, there are numerous small DSA tenant agencies at SMC-managed depots, and a few SMC tenant activities at DSA depots.

Numerous carefully constructed inter-Service agreements have been negotiated in which some of the services provided by and between DSA and SMC are on a common service, nonreimbursable basis, mostly administrative support, while others are reimbursable. A prime example of these agreements would be the overall warehousing agreement under which both parties set forth the terms and rates for warehousing and handling each other's stocks. Under that agreement, we expect to receive some 30 million dollars in reimbursement from DSA this fiscal year.

For these agreements to work, both Army and DSA sometimes have to provide each other resources. This year DSA had to provide SMC with 1,700 personnel spaces for work to be performed at three SMC depots, and, in turn, we provided DSA 360 spaces for work to be performed at one DSA depot.

Obviously the relationship between SMC and DSA demands a high level of confidence and mutual trust. We consider our working relationship with DSA to be excellent, and this condition is a real asset during this difficult period of overall change.

I will be brief concerning my remaining requirement, to discuss flexibility provided in performing our mission. Certainly the wherewithal by which we manage has been in short supply within Department of Defense the past few years. With limited manpower and financial resources by which to perform an ever-growing job, the trend has been toward centralized control at the highest levels. Centralized control does not promote flexibility, as you well know, and every move in this direction starts a chain reaction right on down to the operating level. Some of the points discussed here today indicate that SMC is following the current trend. Standardization of depot organization and supply procedures and centralized programming under Project SPEED illustrate the point.

In concluding my remarks, let me say that I hope I have given you a better understanding of SMC's role in the Army.

## MANAGING THE TEST AND EVALUATION COMMAND

Major General  
JAMES W. SUTHERLAND, JR.  
Commanding General  
U. S. Army Test and Evaluation Command

My subject calls to mind a story about Frank Gilbreth, known to most of you as one of the pioneers of scientific management. Though most of you will recall readily his innovations and experiments in the field of time and motion studies which gained him a reputation as an industrial efficiency expert, perhaps fewer of you realize that he applied these same principles in experiments conducted at home. He buttoned his vest bottom-to-top because this only took three seconds, while the top-to-bottom route took seven. He used two shaving brushes to lather his face because this saved 17 seconds of his shaving time for other purposes. Now, I call that taking management seriously!

### Present Environment

Before discussing with you some of the details of managing USATECOM, I should like to give you my description of some of the characteristics of the contemporary environment in which the command is operating and accomplishing its missions. The environment in which USATECOM must operate is quite different than the environment for testing Army materiel which existed prior to the reorganization of the Army.

1. The Army reorganization placed in one command all of the test agencies — proving grounds, ranges, and service test boards — under the Commanding General of the Army Materiel Command. This created a command structure and an environment in which comprehensive coordination of testing could be accomplished, redundant testing eliminated, and unnecessary duplication reduced to the minimum. At the same time, it created an environment which caused these questions to be asked: Can this test organization properly represent the user of the equipment? Can it be independent and objective?

---

*General Sutherland attended the University of Arkansas in 1936-40 and began his military career in May 1940 when commissioned a second lieutenant in the Officers' Reserve Corps. He entered active duty in July 1940, and was assigned to the 6th Infantry Regiment, Jefferson Barracks, St. Louis, Missouri. He was then sent to the Infantry School (Fort Benning, Georgia) for training. He reported to the Sixth Infantry in August 1940 at Fort Knox, where it had moved to become a part of the 1st Armored Division.*

2. The new organization brought about more extensive use of the project manager system and more emphasis on the total management of a new development program. The project manager is, rightfully so, primarily concerned with meeting time schedules. As far as the time schedules are concerned, his rewards for success and penalties for failure are immediate, whereas the rewards for good quality and the penalties for poor quality are delayed. Therefore the project manager, when faced with the decision of meeting a time schedule or delaying the program in order to achieve better quality and reliability, invariably wants to pursue the course of meeting the time schedule. Such an attitude and such an environment is in direct opposition to the objectives of the Test and Evaluation Command.

3. The five Commodity Commands of the Army Materiel Command, each having certain in-house or laboratory-type testing facilities, adopt varying attitudes toward the mission and responsibilities of USATECOM. These Commodity Commands often exert pressure for more speed in testing with a consequent release for production with a reduction in testing time, "accusation of over-testing," and an expression of an opinion that testing should provide minimum "interference" with development.

4. As you will see later in my discussion, during the past year and a half, the work load of the Test and Evaluation Command has increased steadily, and, during the same period, the strength of the Command has been reduced by over 3,000 spaces. Therefore we operate in an environment in which it is expected that the Command accomplish more work than was done before with less personnel resources.

5. The Army and the Materiel Command are dedicated to reducing development lead time. The tester has a goal to meet in this overall effort to reduce lead time. Our goal is to complete all essential testing in one year, or less, and, for the most part, this goal is being met.

---

*From August 1940 to June 1941 he received various assignments in the 6th Armored Infantry Regiment, and in July 1941 was commissioned a second lieutenant in the Regular Army. He remained with the 6th Armored Infantry, 1st Armored Division, for the next three years, and participated in combat in Algeria, Tunisia, and Italy. He was promoted to the grade of lieutenant colonel in May 1944 and, when wounded at Anzio in June 1944, was commanding the 2d Battalion, 6th Armored Infantry.*

*He was medically evacuated to the U. S. in August 1944, and then joined the Armored Board, Fort Knox, Kentucky, in November 1944. He remained there until June 1947, when he was transferred to the R&D Division of Army Ground Forces, Fort Monroe, Virginia. For the next three years he served as a staff officer in the section responsible for supervision of development of tanks, tank weapons, automotive equipment, and special-purpose vehicles.*

*In June 1950 he was selected to attend the C&GS College, and, upon graduation in 1951, was assigned to the Army Section of the Military Assistance Advisory Group, Belgium-Luxembourg. During this three-year tour he served as Executive Officer of the Army Section and Chief of the Training Branch.*

6. In order to accomplish adequate planning over a five-year period, USATECOM should have relatively firm funding and program information from DA, AMC, and the Commodity Commands. As you will see later in my discussion, the Command is heavily dependent upon programming inputs from the Commodity Commands and project managers. In the contemporary environment these inputs are often not forthcoming. Therefore the Command's plans must be very flexible and we must be prepared to respond effectively to unprogrammed requirements for tests.

7. The contemporary OSD and DA environmental technique is that the decision to produce a new item of equipment, the adoption of a new organization, etc., must be supported wherever possible with factual data. Reliance on individual judgment or "emotional support" must be reduced to the absolute minimum. In such an environment USATECOM must insure that the test data obtained be valid and that the tests conducted be completely objective.

8. Everyone seems to support the idea that we should always try for "quantum jumps" and regular advances in our development programs. However, as testers we often find that not everyone is ready to accept the fact that strengthening the weight of the art generally means that we must be prepared to live with a reduction in reliability for a considerable period of time.

9. You are all aware that we are increasing our technical knowledge at a fantastic rate. I have heard it estimated that this rate is 22% a year. This means that we more than double what we know about ourselves and the world and space around us in less than four years time. USATECOM is driven relentlessly by the accelerating momentum of the scientific output. Not a day goes by that we do not see some new idea or some new development arrive on the scene. Therefore it is essential in such an environment that the Command's plans be such that it is always prepared to test these new items and developments and be responsive to the Army's testing

---

*In July 1954, he returned to the U. S., and to a second assignment with the 1st Armored Division, Fort Hood, Texas, first as executive officer, Combat Command B and later as commander of the 100th Tank Battalion.*

*Upon promotion to colonel in January 1955, he was ordered to the Pentagon for duty with the Office, Chief of R&D. Until May 1956 he was Chief of the Combat Arms Division. He was then transferred to the position of Executive Officer, Office of the Chief of R&D.*

*He graduated from the National War College in June 1959, when he went to Europe for duty with the 3d Armored Division (Spearhead), where he commanded Combat Command B from July 1959 to December 1960.*

*In December 1960 he reported for duty with the Operations Division, Headquarters, U. S. Army, Europe. Initially he was Chief, Plans & Requirements Branch; later he was the Assistant Deputy Chief of Staff, Operations.*

*He assumed duty with the Office, Chief of R&D, in April 1962. In July of that year, following promotion to brigadier general, he was made commander of the CDC Experimentation Center (Fort Ord).*

*(The present paper was delivered at USAMS, Fort Belvoir, Virginia, on 19 May 1964.)*

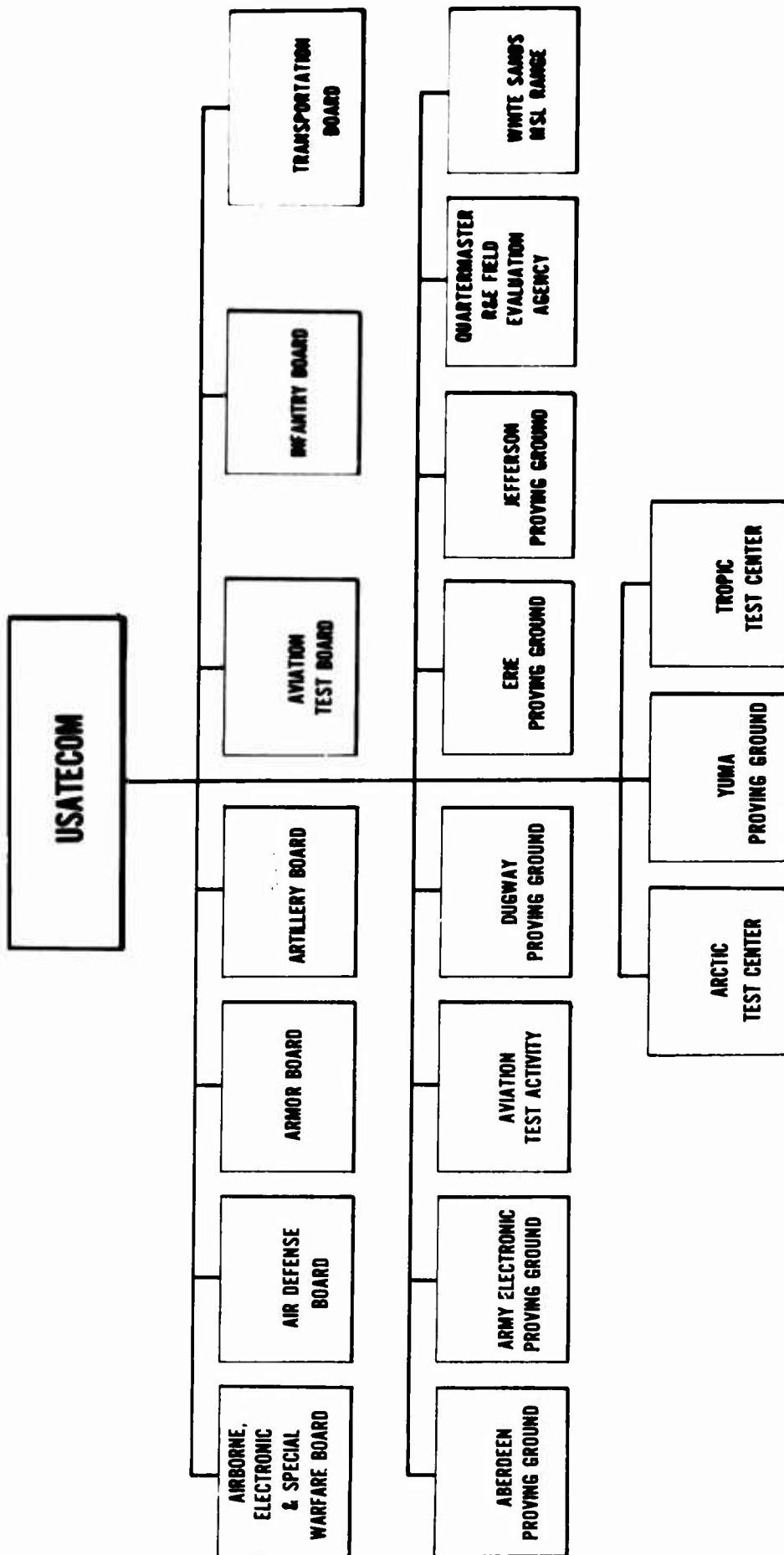

Fig. 1.

needs. The rapidly changing requirements for improved testing facilities, procedures, instrumentation, and management techniques make special demands on the Command for adequate long-range planning. We in TECOM do not propose to try to stop or delay these changes and requirements, and we do hope to be able to accept them and be prepared to respond effectively to them. We testers are acutely aware that we are generating new technical data at a fantastic rate. (In fact, the Army testers have been generating new information at a high rate for the last 20 years.) We recognize the urgent need for a better system of managing technical information for we are often disturbed that test data which have been obtained are too often filed, lost, or forgotten, with the result that in development we continue to make the same or similar technical errors.

This describes briefly some of the characteristics of the environment in which the Test and Evaluation Command operates. Now I shall briefly outline for you some of the major management practices we have so far adopted. Some are old and trusted friends. Others are new ventures where practices did not exist.

Because most of you are familiar with the USATECOM mission and organization, I shall refer to these only very quickly. Then I shall outline, in turn, our management of money, tests, test information, people and work, and, finally, touch on our management improvement programs.

### **Mission**

The USATECOM mission, in brief, is this: this command is responsible for the planning and conduct of engineering and service tests of Army materiel. Our primary product is test reports, and, also, we provide test services and support to DA, DOD, and other Government agencies as required.

### **Command Organization**

The testing portion of this mission breaks down into several categories of tests, one of which we call engineering and service tests. In the center of Fig. 1 are shown the proving grounds, ranges, and test agencies primarily responsible for the engineering tests. At the top are the boards responsible for the service tests; and the environmental centers, shown at the bottom, are each responsible for the tests peculiar to Arctic, desert, or tropic. A second category of tests comprises approximately  $\frac{2}{3}$  of our workload. It involves the engineer/design tests, acceptance, initial production and post production tests which we perform as a service for the Commodity Commands of the Army or for other development agencies.

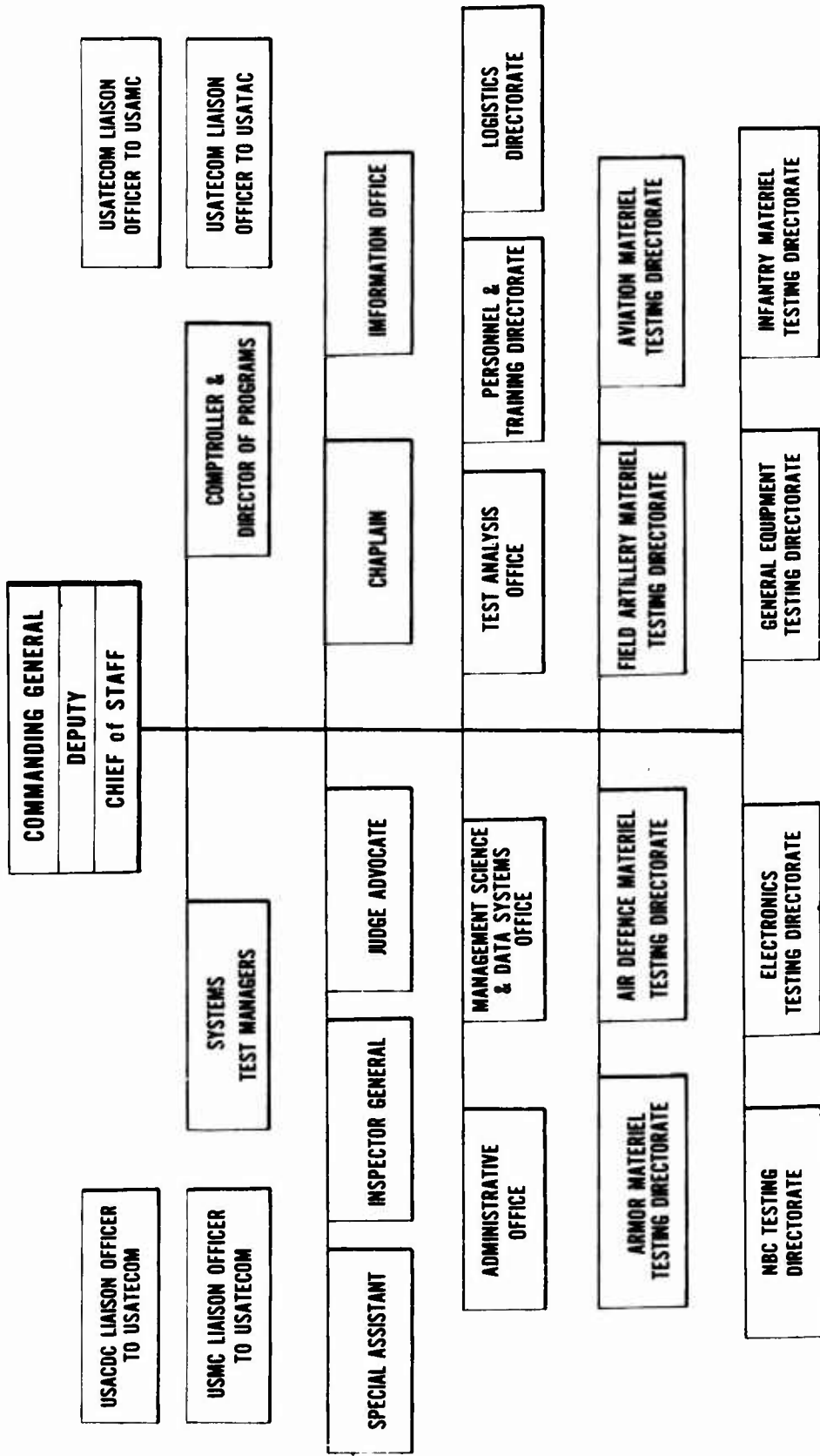

Fig. 2. Headquarters US Army Test & Evaluation Command.

### **Headquarters Organization**

Figure 2 shows the organization of USATECOM Headquarters set up to manage the testing organizations. Eight test directors control the testing, each within the framework of one arm or specialized area of primary interest. Thus the Director of Field Artillery Materiel Testing is responsible for all tests of an entire missile system, and the Director of Armor Materiel Testing is responsible for all tests of an entire tank weapon system.

This is a conventional headquarters organizational structure. With one or two exceptions, it has proven to be adequate during the first 18 months of TECOM operation. However, DA and AMC policy, recently issued, will require some changes in the establishment of a centralized management information center in my Headquarters. My staff is now determining the way in which this policy can be implemented.

### **Financial Management**

Our management of money follows two paths. The first, pertaining to engineering and service testing, flows from AMC through USATECOM Headquarters to the organizations performing the testing. The second pertains to testing performed as a service for other commands, and flows from AMC to the appropriate development command and, thence, in coordination with my headquarters, directly to the testing agency which will do the testing.

My control of the workload in the testing agencies is provided through the medium of test directives issued by my Headquarters. Therefore, coordination through my Headquarters is necessary for the control and management of funds not funneled through my Headquarters. Only at USATECOM Headquarters does knowledge exist as to the availability of testing capability throughout the Command as represented by uncommitted manpower, and the available instrumentation and testing facilities.

Review and analysis of our programs is the responsibility of the Comptroller and Director of Programs.

Our total available FY 63 funds were \$255.5 million. Our anticipated FY 64 total workload is \$275.6 million, an increase of \$20.1 million. As Inter-Command (U. S. Army) Programming is refined, I anticipate an additional workload of \$20 million during this fiscal year, making a total effort of close to \$300 million.

The simple, direct, centralized management of funds for testing, initiated within USATECOM, makes possible for the first time a comparative monetary analysis of the value received from testing versus the dollars spent.

## Test Programs

The management of tests and test information has been a fertile field for innovation in the Test and Evaluation Command. To illustrate, much has been said about the relative merits of the three types of test programs specified by AR 70-10: integrated, concurrent, and sequential. Because of the emphasis placed on the virtues of the integrated test to reduce lead time in the testing of large missiles and other relatively expensive systems, the easy conclusion was drawn that the integrated test is the quickest and most efficient. This conclusion is just not valid except in the very special case of an expensive system for which only a small number of testing prototypes are available. Even then there are drawbacks. For instance, such evaluation must be based on a statistically small sample, and therefore there is usually some compromise in the engineering and service test requirements with their mutually conflicting needs for a controlled environment on the one hand and a tactical environment on the other. Concurrent tests are the preferred type and save most time without compromise of conflicting test objectives. Actually, most testing includes some of each type of test program. In the final analysis, what is important is that coordination which makes best use of the available resources while reducing unnecessary duplication to the minimum, is now a standard USATECOM management practice. Other management actions to improve quality of testing include:

Emphasis on improved statistical methodology in engineering tests to enhance validity of results, or to determine, at least, the confidence level expected or achieved.

Emphasis on elimination of redundant tests.

Doing only those tests which are necessary for the decisions of the Army; not doing those tests which are unnecessary.

Tests conducted by several separate commands prior to the birth of the Test and Evaluation Command were conducted under some 75 different names. Many names were confusing, synonymous, or applied to more than one type of test. In the interest of sound management and to reduce the incidence of misunderstanding, the number of names has been reduced and a single definition is being applied to each. All Army tests are now conducted under the titles which have been coded for use in our management system.

Incidentally, it is interesting to note that these tests (ET and ST) comprise only about 30% of our workload. Two of our test agencies, Erie and Jefferson Proving Grounds, perform only engineer design and post production testing.

Managing test information was an early requirement of the Test and Evaluation Command. First, it was necessary to measure the job assigned USATECOM, and, second, it was necessary to create

a vehicle that would provide the necessary information for efficient management.

## **TEAMS**

It was to meet these problems head on that our Test Evaluation, Analysis and Management System was designed.

TEAMS is a new concept in management. It is an inventory of all USATECOM testing activities. It provides a means for writing simple directives on standard format for the great bulk of routine tests. Thus it saves time for directors to use in writing complicated test directives.

It is a means of simply assigning coordinating instructions to multiple test agencies on any test with a minimum of misunderstanding and a maximum of efficiency because of its standard definitions and vocabulary.

It is a status report of testing in progress. It is therefore a justification for resources.

It is a warning of impending trouble.

It is a checklist of tests scheduled for a given month.

It is a historical record and it provides a basis for statistical data. (It contains data on which analyses of testing trouble patterns can point out areas for possible improvement of testing methods or techniques.)

Finally, it is an up-to-date working file based on a 24-hour updating cycle. For simple tasks it will record the fact of a test and its completion, for the most complicated coordinated test plan, involving many plans of test, integrated, concurrent, or sequential; it will keep an up-to-date status report on all current phases of the test.

TEAMS is a combination of exception reporting and critical events reporting on an "as occurs" basis.

The full value of TEAMS will not be achieved until sometime next year when the availability of a computer makes the system more versatile and self-sufficient and less dependent on high salaried proof readers.

## **Management Revolution**

As I stated at the beginning of my talk, we are in the midst of the greatest management revolution in the history of man, a revolution in which not only is there a desire to abandon conventional concepts, but also a desire to overcome traditional limitations. Man now possesses the techniques to do this and to face up to reality.

Conventionalism is no longer an acceptable solution to any management problem. The explosive development of automatic data processing and the utilization of operations research in decision making and planning make it necessary that all of us accept the fact that we can no longer do things the way we used to. We are now committed to the implementation of more systems changes than perhaps have occurred in the history of the Army itself. The Army is going into computer operations up to the hilt. I am sure that there are many cases already where computer data banks don't work — where the computers are really garbage pails into which has been dumped a horrible accumulation of data that is no good and which is producing the same kind of results, only with more paper.

I have mentioned but few of the data-systems and management-information problems which we now face. When the DA management-information program really gets rolling, we will have placed upon our shoulders a tremendous burden of creating a whole new technology in the field of data processing. And, as you contemplate this, if you are scared, you are smart. I am grateful that we have made some progress in our TEAMS system, since it does give us in TECOM a solid foundation for the building of our total management information program.

### **Management Improvement Programs**

Our management improvement program in USATECOM is oriented primarily to the management of resources.

By using work measurement, work simplification, organization/mission planning, data systems, and reports management programs, we hope to find and use better ways of managing our resources and accomplishing the missions assigned us.

During the first year of operation USATECOM realized \$4.5 million in tangible savings through these programs. Our target this year is twice that amount.

Our approach to management improvement is to guard against relative overimprovement in one area by efforts to achieve perfection where it is not needed.

### **Work Improvement**

The strength of a chain is not increased by making a single link many times stronger than others. Such effort can be downright wasteful of resources. The concern of management must be with chain of equally strong links, adequate to serve the purpose for which intended.

Sometimes I am concerned about our efforts to improve our operations. Occasionally we find someone spending long hours to measure or improve an operation which we shouldn't even be performing in the first place. We must be constantly on guard against such endeavors.

Earlier I mentioned work measurement as though this program were some time in the distant future. In actual fact, we have already begun an innovation in management in this command, a system designed to manage work and the manpower directly associated with this work.

For years the Army has tried to do this on a broad basis. However, in the present management environment, with constant reductions in manpower and the emphasis on increasing the productivity of government employees, the old methods of assessing our workload capability no longer suffice. Under the present concepts of programming and review and analysis, we must be more precise and definitive in assessing our use of manpower and justifying the allocations to the tasks assigned. The people in higher headquarters who decide on manpower allocations are critical and resolute in reviewing manpower requirements and will not accept broad statements and generalities. Accordingly, we must convince them we are using our manpower resources well and associate any increases required with concrete requirements. We hope that our system of work scheduling will meet these requirements.

Now, what is the concept for scheduling the work within Test and Evaluation Command? In this connection I have some key policies which are the basis for planning the use of our manpower.

In testing and all other work we do in Test and Evaluation Command, it is my policy that high-quality standards of performance will be maintained. Maintenance of high standards insures that we do an effective job.

It is also my policy — and this is the key to the entire philosophy of the system — that we will defer tests or other tasks if standards must be compromised because of shortages of manpower resources. In other words, everything we initiate will be done well; and, if this objective cannot be met, due to manpower shortages, we delay or defer the work and, at the same time, notify higher headquarters of the action taken. In determining the work to be deferred or delayed, we allocate available manpower to projects having the highest priorities.

I receive data each quarter projecting a schedule of work, and the manpower assigned for each of the succeeding two fiscal quarters. Test labor is identified with each and every test we have the capability to perform. Test support is scheduled in a lump sum. Likewise, the overhead manpower is scheduled in total for each USATECOM

installation and activity. If a test activity should be so fortunate as to have some manpower for which no work is scheduled, it is indicated as uncommitted manpower. Believe me, we have very little uncommitted manpower. Theoretically, uncommitted manpower is my reservoir or reserve of manpower for performing unprogramed work.

The totals of the four categories of manpower equal the total authorization of the Test and Evaluation Command. As you might suspect, this information is quite valuable to me. At a glance I can detect the portion of our manpower being used in mission work as compared to overhead. What really concerns me more, though, is the work we do not have the capability of performing and therefore must defer, the specific tests involved, and how much manpower is needed to perform this work. Work schedule reports show me the specific tests which must be deferred and the manpower required to perform them.

As I mentioned earlier, work schedules contain a list of all tests scheduled for the succeeding two quarters, a brief description of the item of equipment being tested, the Department of Army RDT&E project number, the Army management system code, the manpower required for each test, and the recommended priority of the test. Priority A means the manpower is available for the test, while B indicates the test is recommended for deferral. It is important to note that, using this system, we are now able to identify our manpower costs for test projects with the program and budget structure of the Army. This facilitates justifying the manpower required and establishes a basis for integrating manpower information into an overall management information system.

In reviewing how the subordinate commands plan to use their manpower, I note the proportions of manpower used in the three major categories of work—direct labor, direct support of testing, and overhead. Why should overhead costs range from 40 to 54% of the total personnel available at six TECOM installations? The same question applies to the range of 6 to 36% manpower utilization in overhead. Similarly, the variance in manpower scheduled for support and direct labor areas of work raises questions.

Since the system is new and varied interpretations have been applied to the labor, support, and overhead categories of work, we recognize that the data we now have are not totally dependable. However, we are correcting this fault and in the future all commands will be reporting under the same ground rules and the data we receive will provide a sound basis for managing our manpower.

To summarize, work scheduling provides me with a clear picture of my capabilities for performing the missions I have been assigned. I can compare the effort we are capable of with the instructions and

guidance I have received. I know what I can and can't do and what it costs in terms of people to do everything expected of me. I can determine the location of manpower available for unprogramed work and consider shifting uncommitted manpower to high-priority projects. And, finally, it provides my boss, General Besson, a .d Headquarters, Department of the Army, with manpower-shortage information they can readily understand and which will assist them in making decisions based on facts directly bearing on the problem.

I have only touched upon some of the problems associated with the management of the Test and Evaluation Command, the environment in which we are now operating, and the techniques and approaches which we are taking. In the first 18 months we have made significant progress in doing a better job of testing for the Army. I assure you that the management of this command presents many unique management problems, and not all of them have been solved.

As you leave this School, I hope you take with you an awareness of the dynamics which we are now facing in government and in industry. Although each of us, in carrying out his particular management mission, will frequently become concerned about the pace at which we are moving, and about the revolutionary practices and concepts which we see surrounding us, we must never lose sight of the personal challenge which these events give us. The Armed Forces have never failed to accept such challenges in the past. I know we will not fail now.

## PROJECT MANAGEMENT

Brigadier General  
C. W. EIFLER  
Deputy Commanding General  
Land Combat Systems  
U. S. Army Missile Command

The structure of organization and management is like a diamond. It only shines with brilliance if it is cut exactly and flawlessly along its planes of symmetry and is polished to perfection on each of its many surfaces. This paper deals with just one of these many facets, the organizational synthesis of management of technical and industrial efforts, and I submit that management needs systems engineering.

In these modern times this nation is devoting its best scientific effort to discover new laws or to find new adaptations of old ones, and its best engineering effort to work at the very barriers of technology. All of this great scientific and engineering effort is directed to make our way of life more secure and to improve our standard of living. But who determines the organization and management concepts which forge this great technical effort into usable products? Are organizational concepts subjected to the same careful and objective engineering analysis that is used to develop new products, or is this task done by some very fine people who lean heavily on their own experiences and intuition? Perhaps our ideas of management and organization are in a rut, and a rut is simply a grave with the ends knocked out. It is the purpose of this paper to show how we can eliminate some of the ruts in our concepts of organization and management.

Mr. Charles Kettering, of automotive fame, once stated that "... a successful organization needs four kinds of people: the think-it-uppers, the put-it-downers, the work-it-outers, and the get-it-done-ers." Although I am not sure, I suspect that Mr. Kettering, being from the automotive industry, was speaking of the need for engineering, design, product improvement, and manufacturing or production. If I may emulate an oft-repeated phrase, I would say that, in this respect, what is good for General Motors is also good for government products. However, today I would like to hitch-hike upon this statement made

---

*General Eifler assumed his present assignment in April 1963. Prior to that date he was the Commanding Officer of Frankford Arsenal (Philadelphia, Pa.). He went to Frankford after a tour as Commandant of the Ordnance Guided Missile School at Redstone Arsenal, Alabama.*

*General Eifler is a 1936 graduate of Pennsylvania State College, with a B.S. degree in Civil Engineering. In 1948 he received an M.A. in Electrical Engineering from MIT. He later attended the Industrial College of the Armed Forces.*

by Mr. Kettering, and I will say that a successful organization needs four kinds of people: the **Planners**, the **Integrators**, the **Doers**, and the **Anticipators**.

No doubt you will have immediately questioned how such kinds of people can be clearly separated, since most everyone has some of each of these traits. Indeed they do; but each individual has a tendency to predominate to some degree in one or, perhaps, two of these characteristics, and the assigned position in which he finds himself in the management structure serves to emphasize the particular role the individual is required to perform. In a broad sense, the job of training a manager is to develop, through education and experience and usage, a strong capability in all four of these traits. Hence a manager is developed through a series of successive assignments, each of which tends to emphasize a different one of these characteristics above the others.

To more clearly identify what is meant by planners, integrators, doers, and anticipators, I shall discuss each in more detail.

**First, the Planner.** He is the man who exhaustively collects evidence, thinks through many alternative approaches, collates advantages and disadvantages, and presents a well-staffed and objectively-summarized plans for action. Obviously he is a good man to have around, and this soon becomes evident in any organization. He also has some disadvantages. For example: the Planner concentrates his attentions on specific goals or objectives. He does not give balanced attention to equally important objectives which are not a part of his assigned responsibilities. Therefore we also need Integrators.

**The Integrator** is the "shock absorber" of the organization. He has the depth and ability to take the ups and downs with considered judgment, and acts to keep the organization moving along on an even keel. He is an organization stabilizer. He often sees where yesterday's and today's requirements might be combined for a single

---

*He began his military career when commissioned a second lieutenant in 1936. In 1936-39 he served as company officer and commander in the C.C.C. In 1940 he entered on extended active duty at Fort Knox, Kentucky, with the Armored Forces.*

*During World War II he served with various echelons of the Army Ground Forces in Europe, becoming Ordnance Officer of the XVIII Corps (Airborne) in spring 1944. He was also Ordnance Officer of the VII Corps in 1945. Later he was Ordnance Officer of the Sixth Army in California.*

*Following his training at MIT, General Eifler was assigned to missile work at White Sands Proving Ground, New Mexico. After three years as Executive and Technical Operations Officer at the Proving Ground (1948-51) he became Chief, Guided Missile Section, and then of the Rocket Branch in the R&D Division, Office, Chief of Ordnance. In 1956 General Eifler became Commanding Officer of the 57th Ordnance Group at Seventh U. S. Army, Europe. He remained in that post until his assignment as Commandant of the Ordnance Guided Missile School in 1959. Following two years at the Missile School, General Eifler was assigned as Commanding Officer, Frankford Arsenal. He remained in that assignment until his transfer to the Missile Command.*

*(The present paper was presented orally at USAMS, Fort Belvoir, Virginia, on 17 March 1964.)*

effort, and he continually places and adjusts, both the organization and the tasks, to even the workload. Indeed, he is a valuable fellow to have around.

The third type of individual is the **Doer**. He cannot be represented by anyone or anything but himself. Without him, we are "managers of nothing." He is the scientist who is stretching the scientific barriers; the engineer with a knack for inventiveness; the man who has the know-how to lay out an assembly line; the tool and diemaker; the machine tool operator; the mathematician; the designer; etc. He is all the rare talents that permit an organization to do something besides issue paper. In summary, the Doers are the backbone of the organization, and I cannot over-emphasize their importance.

Next is the group of individuals who make the difference between a dynamic organization and one that is sluggish and unresponsive to timely requirements. I call them the **Anticipators**. The Anticipator is a man who is willing to stick his neck out and raise the alarm where more experienced heads would state that the evidence is not sufficient to become concerned. He can be proved wrong: sometimes because he raised the subject in time for somebody else to make sure it wouldn't happen. He must have a keen, analytical mind and a willingness to look ahead where the way is not clear. He should be technically qualified but need not have the inventiveness of a developer nor the production know-how of a plant foreman.

Now that personnel have been categorized by tendencies, I shall construct a management concept in which these talents can best be utilized. The usual approach in drawing organization and management charts is to start with the manager and work down. An engineer, however, starts with the operation he wants to control and then proceeds to develop support and regulation which will permit the degree of control required. Having made this point, I beg your indulgence to present this concept in a forward flow. This is done because it is more easily understood when presented in this order. If some of the comments regarding this construction appear to be light, these are made simply to maintain reading interest and, it is hoped, will not detract from the importance of the concept as it develops.

The first items on my organization chart deal with the inputs (Fig. 1). They can be represented by resources, requirements, and guidance — "apples, bananas, and oranges." Since there are different kinds of inputs, quite obviously a program or project is involved; and, if there is a project, there is a need for management; so I have put down a wedge-shaped box entitled "Project Management." The shape of this box is significant to its mission.

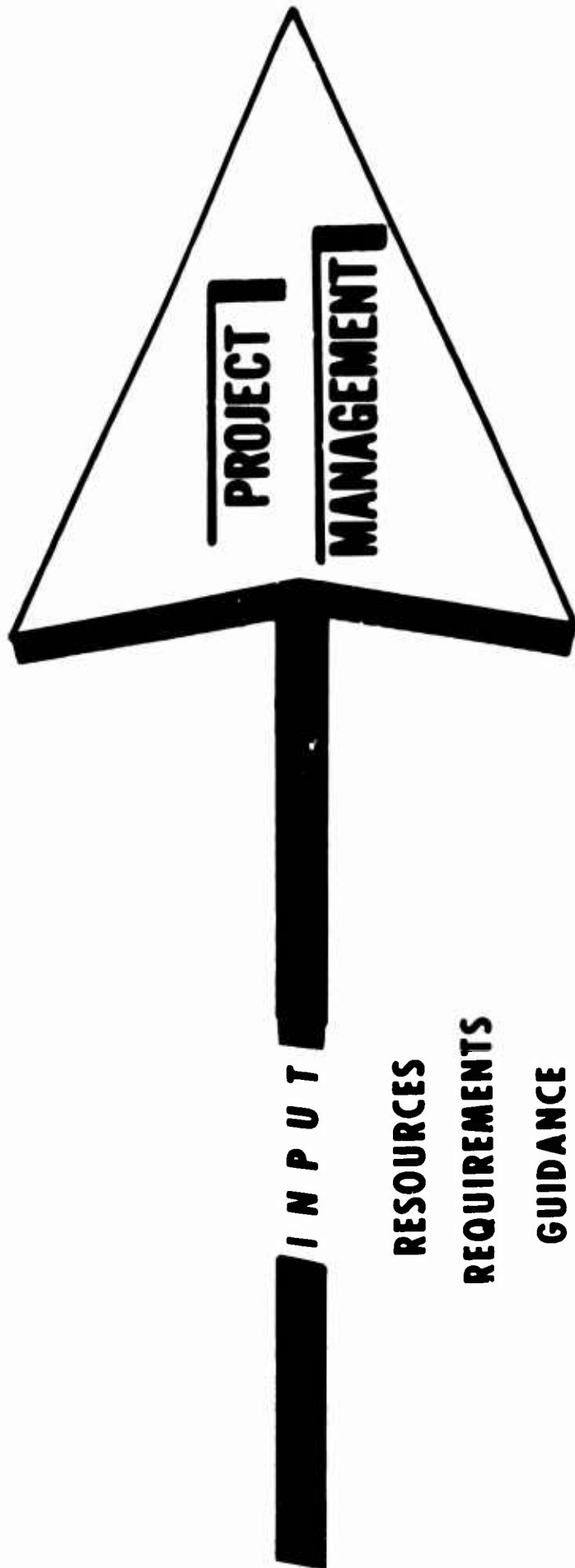

Fig. 1.

Some part of the organization must take the inputs and divide and shape the task within the organizational structure consistent with the abilities of the organization and the requirements, resources, and guidance of the task. Hence the mission of project management is to continually adjust manpower, facilities, equipment, and funds to meet the overall requirements and guidance placed on the organization. It is also project management's responsibility to assure the efficiency and effectiveness of the total organization as related to the specific project being managed. It is in project management that the Planner is most useful.

The size of the project manager's office is a matter of judgment and it differs with each project. Clearly for authoritative control the project office must have full control for project planning, budgeting, and programming; for the broad management and evaluation of the technical and related effort; for integrated scheduling; and for preparation of the project manager's directives. These are fundamental to centralized project control.

In addition, the project manager's staff office must be of sufficient structure and size to maintain continuous day-to-day contact with the operating function elements for those management tasks which are best done in a functional way. The project office must assure effective response to the needs and direction of the project. Such functions as contracting and purchasing, detailed comptroller and fiscal operations, quality and reliability assurance, validation and testing, allotment of skills and facilities, logistic planning and new equipment training, documentation and change control, customer and public relations, etc., are project considerations which are most effectively done either partially or wholly as functional operations. However, the project office must assure that these functional efforts are responsive, within reasonable limits, to the needs of the project.

By this means the project manager and his staff can devote full line attention to the management and execution of the engineering, production, and logistic support of the products or systems for which the manager was created. The prime effort must therefore be directed toward the timely and economical realization of the materiel for which the project manager is responsible, and the remainder of the organization concept concentrates on this prime objective of the project manager.

Having now developed a project and project management, there must be something to manage. It is a well known fact that if managers want to retain their titles, they should never be caught supervising actual work; so what do they manage? They manage supervisors, and I have added the **Functional Supervisors** to this concept (Fig. 2). Supervisors usually have some trouble translating management directives (at least from a management viewpoint), so there must

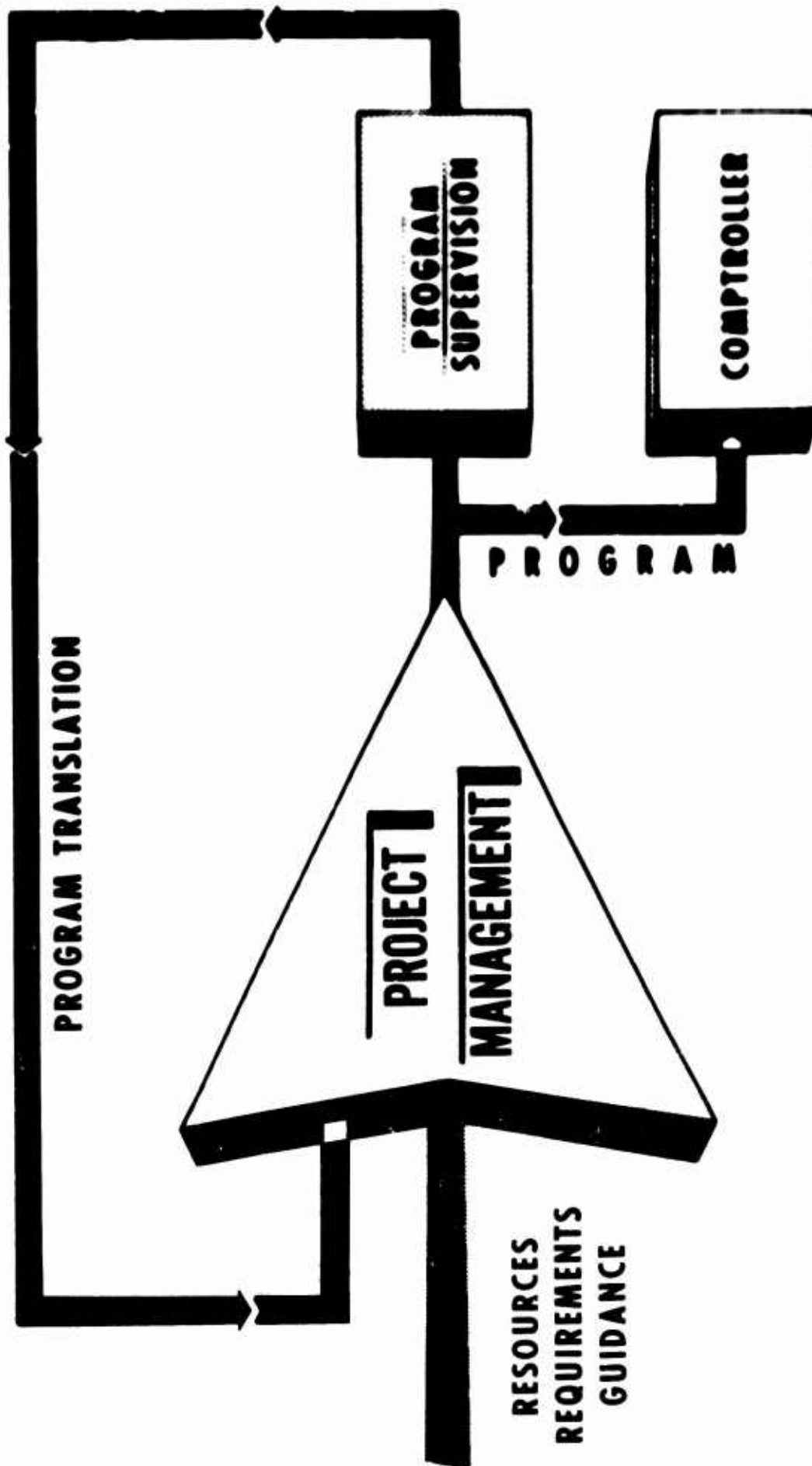

Fig. 2

be some feedback to make sure that the supervisor is implementing in the way management expects it to be done. This feedback is shown as Program Translation. Note that the word is "program," not "project." Functional Supervisors must serve a number of project managers. The requirements of all must be integrated into an effective, timely, and economical program which makes maximum utilization of skills and facilities on a daily basis. Hence I have called these functional supervisors "Integrators."

Also, since funds are involved and bills must be paid, there is a need for fiscal management; and I have added a box entitled "Comptroller." However, this is not the same comptroller that you may be acquainted with. Some of the functions normally assigned to a comptroller are shown elsewhere. For example, internal review is located in project management, and that part of the comptroller's operation known as budget programming, although done by comptroller-type personnel, is also included in the project management box.

Having now completed the figure down to the functional supervisor level, it becomes readily apparent that the supervisors must have someone to supervise. This leads us to the real "doers" of the organization, which I have called "Operations" (Fig. 3). Similar to project management, the supervisor also wants to make sure his guidance is being understood and is acted upon; and he causes certain evaluations to be fed back to his office. These are shown as "Operation Translation."

Operations, in turn, produce something: a product or output. This output can be measured in terms of costs, quantity, quality, timeliness, and customer satisfaction. In order to make such measurements it becomes necessary to collect data on each type of product. So I have added "Data Collection" to this dynamic organization. It is beneficial to bear in mind, at this point, that data may be collected from any particular output of any operation within the Operations box, as well as the measurement of the final product. Data encompasses such things as cost, quality and reliability, deliveries, test results, existing and potential problem areas, design weaknesses, etc.

With these organizational elements established, it is now apparent that cost information may be fed back to the comptroller, and that information is then collated with program guidance and sent back through project management. Also, to step up the cycle, the comptroller may send cost/program collated information direct to the supervisors and, on certain critical items, on a daily or weekly basis, direct to Operations. These are phased internal loops which materially reduce time lag.

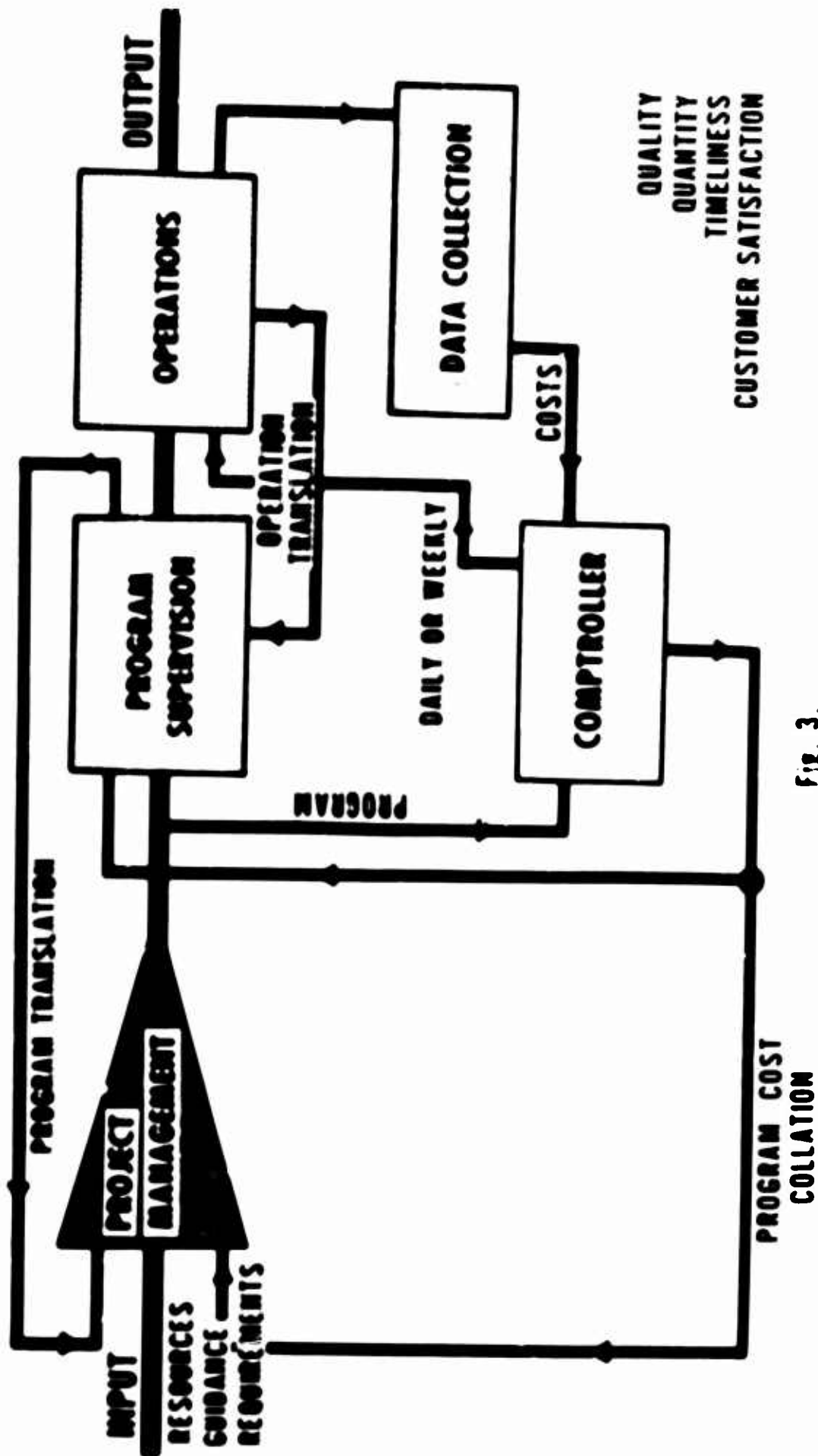

Fig. 3.

Here, then, is a workable system with all the elements necessary to get the job done. However, there is still no provision in this model to evaluate and correlate quantity, quality, timeliness, and customer satisfaction with the initial inputs of resources, requirements, and guidance. Such data do no good resting in the data bank, and the lack of dynamics in passing these data slowly up through successive channels of supervision is well known. It must be available at the management level quickly and used effectively. Since these measurements are usually related to specific projects or products, a box is added entitled "Product Monitors" (Fig. 4).

These Product Monitors add the element of future anticipation to the data collected. They evaluate current status and past performance and project what will happen tomorrow, next week, next month, etc. Current status and present and future expected problems are fed back to the Project Manager. The Product Monitor can once again improve the time response by also feeding his anticipatory results into the organization at just the right places. However, he should never assume the position of direction in the model which I have shown and must always operate at an equivalent or higher level than the supervisory or management structure which bears the overall assigned responsibility for the specific problems he has generated. There is always a tendency on the part of these Project Monitors to want to direct the actual operation. If you want things to really get mixed up in the model which I have created, just allow them to do it. It is the quickest way I know of to make this dynamic model unstable. Since these people are usually in the limelight and normally have the task of conducting high-level briefings, there is a tendency to over-evaluate their contribution in the organization. They are an essential element of this dynamic organization model, but cannot operate effectively without the remainder of the organizational structure, and most certainly must operate as an integral part of the total dynamic concept.

With the addition of the Product Monitors, the dynamic model of a concept for organization is completed. This dynamic model has resources (funds), requirements, and guidance as its input, and produces as an output certain hard goods.

By this time some of you may have recognized the technical counterpart of this dynamic concept of organization. In the next figure let's visualize the manager at the top of the model (Fig. 5). Underneath him we see a dynamic technical counterpart of the organization which I have presented. The shaping network replaces project management. The "Integration" box replaces the functional supervisors who are the Integrators in the organization system. The comptroller has become a Collator, and the Doers are the power device in the model which permits an output of hard goods as its product.

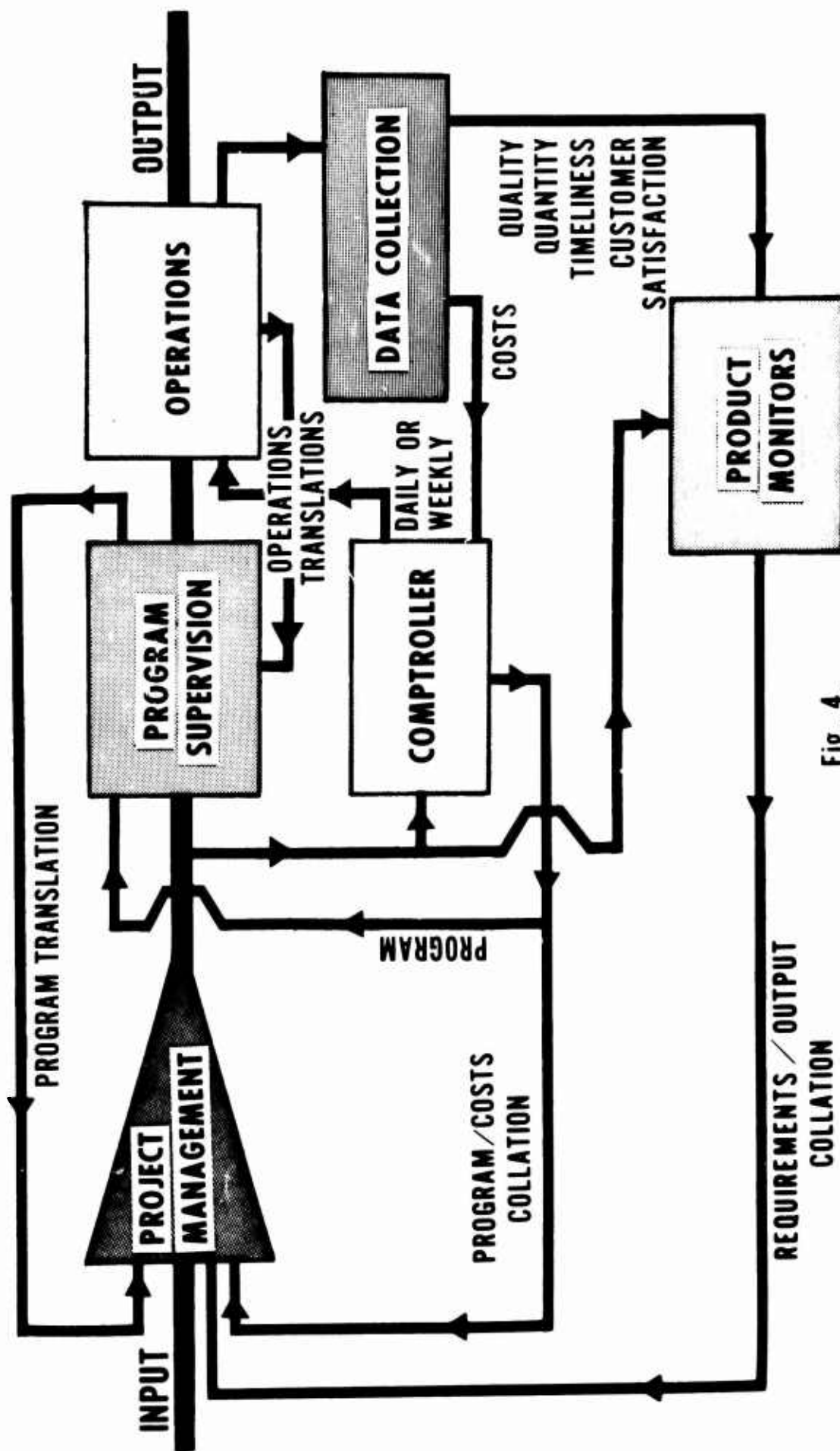

Fig. 4.

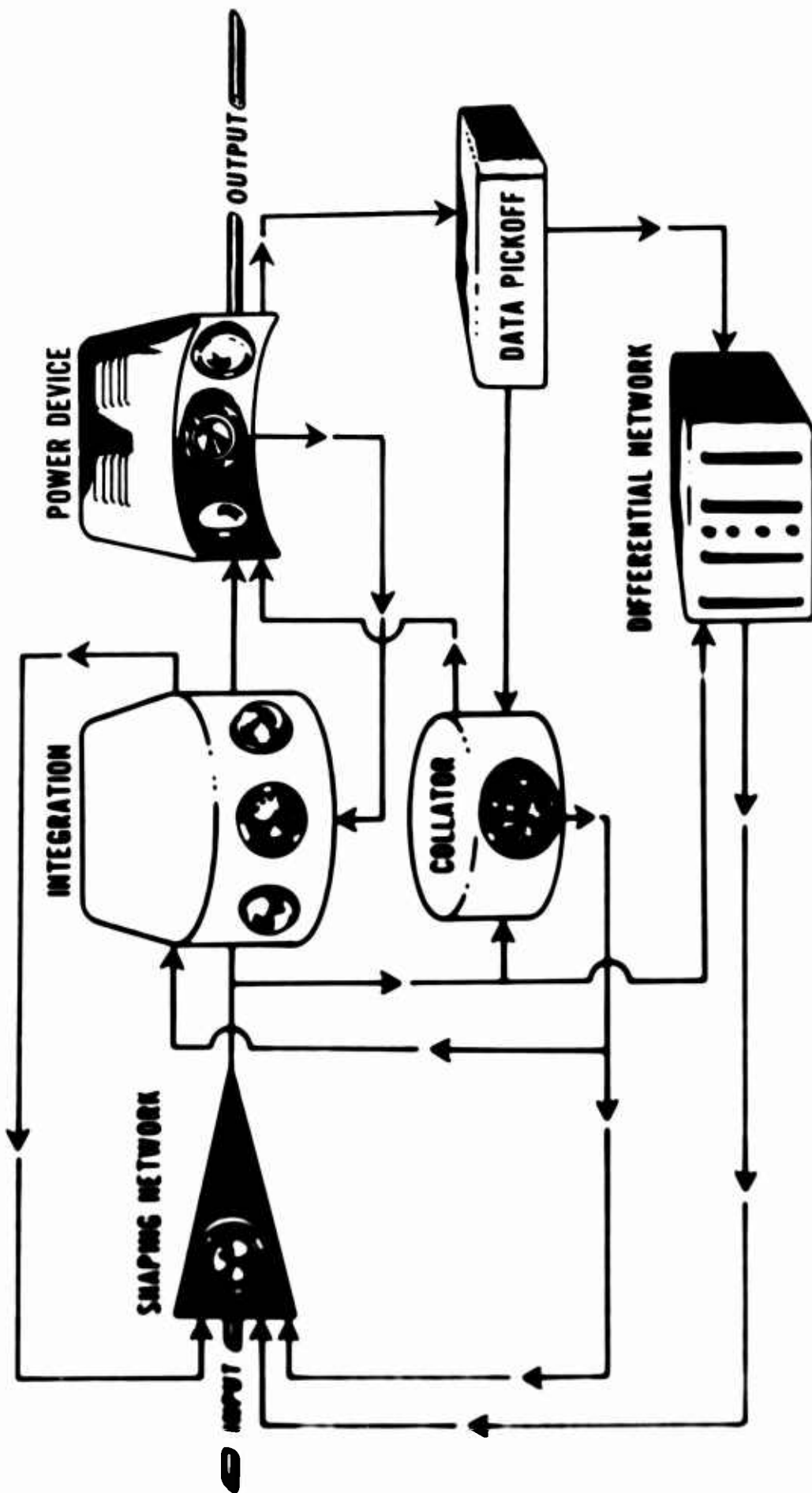

Fig 5

The Product Monitors are a part of the differential feedback network where the Anticipators are located. At the top is the Project Manager and his key directors who, in effect, are the system engineers that continually diagnose the problem areas and provide the necessary adjustments to maintain the system in good dynamic and stable response.

Since individuals who make up this dynamic "machine" are sometimes unpredictable, this really keeps a manager busy. The hand knobs depicted on the dynamic model represent amplification, or gain, in the particular box shown, as well as the time lag through the box. Because of the project or product orientation of Product Monitors, a number of these personnel are required with regard to each type of project. Hence a number of knobs are shown on the differentiating network. By manipulating the gains and time lags in the various boxes, a knowledgeable manager can take care of crises in individual projects and keep the overall system in good performance.

If such a concept of organization is to be a counterpart of a dynamic "closed-loop" system in a technical sense, then just as the technical system must operate on compatible frequencies, voltages, etc., the organization in the same sense must be working in detail off the "same sheet of paper." Such a sheet of paper is called a milestone chart.

The milestone chart serves as a planning document which identifies who is responsible for each action leading to a completion of the project, where the work will be done, and, most important, *when* it will be done. Every participating agency assists in the formulation of this document, which is then initialed by all concerned, up to and including the manager. Any revisions must go through the same process. For more complex projects there is a need for several tiers of milestone charts and, in some instances, the use of more elaborate scheduling techniques utilizing computers. But for most projects (less than 120 distinctly separate operations), the use of the milestone chart is sufficient. Similar planning and control documents are used for costs.

It might logically be asked, what is to be gained from such a concept? How can it be used more effectively than normal organization concepts? First, let us take a look at overall performance (Fig. 6a, b, c). Here performance is represented by quantity and quality. These are not all of the performance factors, but simply serve as representative items. Time is shown as the base. Fig. 6a, shows what can happen when the system is too sluggish, or when the Product Monitors are not effectively anticipating problems. Performance response is slow, and objectives are not fully met.

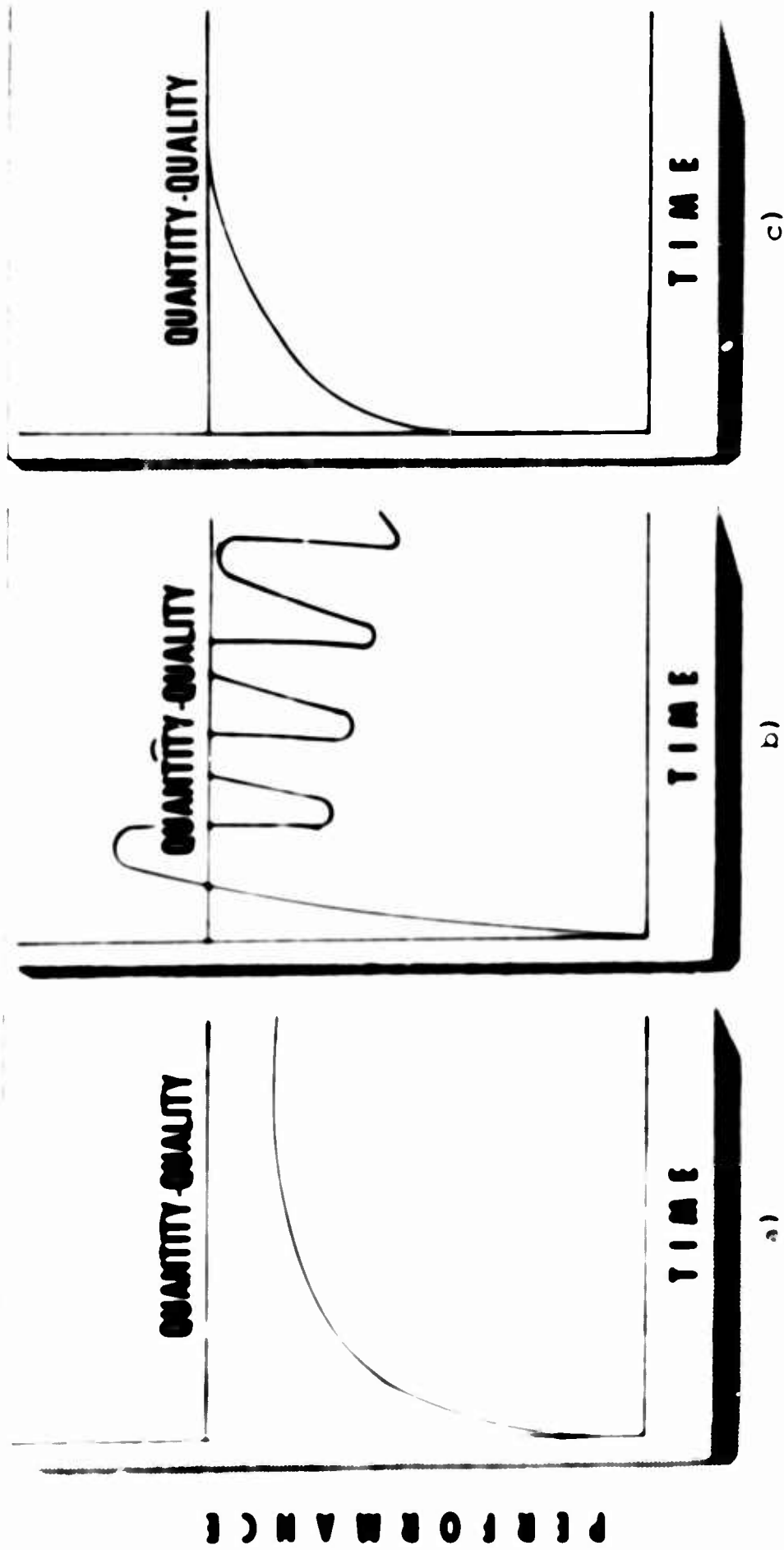

Fig. 6.

Figure 6b, shows what can happen when the system is over energized or out of adjustment. This can happen when proper integration is not accomplished at the functional level, or when project management is simply acting as a messenger service and passing down the worst fears of Product Monitors without a sense of judgment or timing. It is also the type of response to be expected when Product Monitors assume directive-type authority. Response to some requirements rises rapidly and may even exceed expectations. On the other hand, response to other requirements falls off and the organization begins to surge. Overall performance gradually deteriorates.

Figure 6c, shows what I call critically energized response: just the right amount of feedback by Product Monitors and an equivalent amount of timely absorption by the organization, everything in perfect harmony, and overall performance is premium.

To achieve such quality performance one must be able to clearly define the problems that arise and correctly evaluate where in the organization structure adjustment is best made, and to rebalance the system after correction. To a systems engineer several fundamentals appear applicable for good system response. First, there are two major feedback loops which serve to keep the system dynamic: the program/cost collation and the Product Monitors. Both contain the element of anticipation, but the Product Monitor loop is significantly more anticipatory and dynamic in an overall sense.

When funds are very limited for the project, then the fund control loop becomes very tight and will restrict the level of effort applied to the component tasks. Thus quality and schedules may suffer unless corresponding attention is given to the feedback from Product Monitors.

When funds are adequate and cost control is not as rigid, there is still a need for the Product Monitors. In this case, since the internal cost loop has considerably less effect on the system, the Product Monitors are needed to keep efficiency and effectiveness and to prevent the system from becoming sluggish. Hence the Product Monitors are always vitally necessary to good system operation.

Second, the response of the system is most critical to the "shaping" activities of project management. When serious problems arise and Product Monitors are forecasting chaos and failure, project management must act very much like the integral shaping network of the technical system counterpart. The worst fears of the Product Monitors must be absorbed to some degree until the exact circumstances are established and an overall concept can be devised to which the entire organization can direct its full efforts to achieve the best overall solution. Otherwise, both funds and effort will be employed in a piecemeal way that will detract from other important work and reduce efficiency and effectiveness. Also, that other important

work soon becomes a problem, and effort must be directed to it perhaps at the expense of the first project. The organization begins to surge, and overall performance will soon fall.

On the other hand, when things are going smoothly, project management may act much as a "lead network" of the technical counterpart. The Product Monitors' reports may be amplified. Small problems receive stronger attention, the pace steps up, and the overall response is more lively.

Because there are a number of Product Monitors for any large system, necessary adjustments need only be made in those parts of the project affected by the problem.

Similar analysis can be given to the functional supervisors who are responsible for the overall efficient and effective performance of the functional organizations and must be responsive to a number of project managers. Functional operations must be tailored on a continuing basis to best undertake and continue the total functional tasks assigned, regardless of whether these come from one or several project managers. Sometimes there is unused capacity; at other times too little capacity is available to meet current needs. The functional supervisor must be able to tailor his organization by continual balancing of skills and facilities with workload, and to acquire outside contracting where necessary, in order to assure a balanced, efficient, and effective performance. Placing unreasonable demands on over-taxed functions does not provide good overall system performance and reflects in the output products.

This integrating function must exist in any successful organization. If it is not included by design, then it will evolve throughout the operational chain, or the operations will once again surge back and forth, based upon the pressures of the hour. It is much more practical to design integration into the system in such a manner that it can be adjusted and controlled continuously for best overall system response.

For a knowledgeable system manager, as experience in the application of the dynamic organization structure grows, many other basic concepts will come to light as he increases or decreases emphasis and timing of each part of the organization. In a relatively short time he becomes experienced in the capabilities and limitations of the organization and, thinking in a system sense, will take actions to strengthen and speed up that part of the organization that is causing less than optimum performance.

Now I want to point out several things about these concepts. First, I draw a box around Operations as a single entity. Actually, this box not only represents all of the functional operating groups but also a complex network of its own, involving in-house operations, procurement and contracting, etc. This, again, is an old engineering

trick of finding out what the model should be; identifying the model in terms of inputs and outputs; placing it in a hypothetical box; closing the lid; and then proceeding to other components of the system. These same techniques can be applied to organizations or arsenals in their identification of a higher network and to companies or commands within a still higher network. Every so often, the Inspector General, the Manpower Survey Team, the Army Audit Agency, the Bureau of the Budget, or the General Accounting Office, open up this hypothetical box and check all or part of the internal operation. Sometimes things really get out of adjustment and a complete rebuild is necessary.

The second point I wish to make, and an important one, is that I have shown you a dynamic model which involves paper inputs and product, or hard good, outputs. This is not the kind of model one would use for personnel relations, for example, nor is it the model one should use for long-range planning and forecasting. In this respect an organization must perform as a complex computer. Too often we inadvertently and unknowingly create a poorly constructed organizational operation which simulates an analogue model of a computer, with all the problems of drift, error, interrelated complexity, and inability to identify faults.

I submit that the language and symbology and construction of a digitalized computer model of organization concept is a much more effective means for programing the actions required, for checking the results, and for appropriate control to insure the quality of the output. One point should be made clear. The use of an organizational concept based on a pattern of a computer does not entitle the manager to expect a speed of response equivalent to that of the modern electronic computer, and the impatience of the manager does not really help in the quality of the output.

Finally, I want to return to the normal organizational construction (Fig. 7). At the top of this figure is a sketch of the way we are used to seeing plant organization. With a little imagination, you can see the resemblance to the dynamic model which I previously constructed except, perhaps, for one thing (see lower part of figure): there should be a line flowing from the bottom of each functional organization to the Product Monitors' box. Note the direction of the arrow is *up*, not down. You cannot push from both the top and the bottom without getting an accordion effect and plenty of bad music.

In conclusion, permit me to read a quotation from the famous English scientist, Thomas Huxley, who was a self-educated man and whose life was devoted to "the mechanical engineering of living machines."



"Science is nothing but trained common sense, differing from the latter only as a veteran may from a raw recruit; and its methods differ from those of common sense, only as the guardsman's cut and thrust differ from the manner in which the savage wields his club."

What I have presented is a rapier, not a bludgeon. In the mind of a knowledgeable and technically-minded manager it can be a highly effective methodology. The effective day-to-day balancing of functional skills and facilities by functional supervisors is made responsive to strong vertical management to provide a completely integrated system concept. Functional supervisors have clearly assigned responsibility for control of their functional organizations. The project manager has a direct feedback of how well the functional organization is accomplishing his requirements and has full line authority for his project. It is only when the resources available to the functional supervisor are inadequate to meet the needs of all project managers that it will be necessary for the plant manager to add his authority and judgment to the resolution of problems.

## INTERNAL AUDITING AND THE ARMY AUDIT AGENCY

Mr.  
JAMES A. ROBBINS  
Deputy Chief  
U. S. Army Audit Agency

We are very grateful to the Army Management School for inviting us, over the years, to talk to you about the Army Audit Agency, its organization and its mission. I can truthfully say, having come here for a number of years, that there were times when, on the drive from Washington to Fort Belvoir, I wished I would have a flat tire so that I couldn't complete the trip. Some of the past sessions have been rough at times. I am not going to talk very long, but I would like to briefly explain the U. S. Army Audit Agency's mission and organization.

### *Background*

The Army Audit Agency's charter is AR 36-5. This regulation is based on Department of Defense Directive 7600.2, which states that in each of the Military Services there shall be only one audit organization, which shall be at the Departmental level. AR 36-5 outlines the responsibility for audit in the Department of the Army, and places it with the Army Audit Agency.

The AR defines the scope of audit and, as literally interpreted, the scope of our audit responsibility is in the area of financial management. Of course a question has frequently been raised as to where financial management ends in relation to Army operations. I think it is reasonable to say that there is no end, that any operation within the Army has financial significance. That interpretation of financial management in terms of audit has raised questions from time to time whenever an auditor goes beyond the pure bookkeeping function. I think most of us have traditionally thought of an audit as being something concerned only with the verification of books and records.

In 1953 the Army Audit Agency started to broaden its scope of auditing Army installations to constitute what we term "internal

---

*Mr. Robbins attended Syracuse University and holds a B.S. degree in Accounting from Columbus University, Washington, D. C. He has been a professor of Internal Accounting at the latter university, and has also taught Advanced Accounting at the Department of Agriculture Graduate School.*

*Mr. Robbins has held the following Federal positions: Chief of Accounting Systems and Procedures, Assistant Director of Audits, Assistant to the Comptroller—*

audit." The Agency thus started to broaden the concepts of audit theretofore performed in the Army, from auditing military property accounts to auditing all Army installation activities having financial significance.

Up until about two years ago we largely confined our scope of audit to directly-related financial activities, only at times getting into supply operations in their broader aspects. With the advent of the new administration in the Department of Defense, the Agency has been asked by the Department of the Army to do more and more things which up to that time had been far beyond what we normally did. The first of these special requests, actually directives, was from Mr. McNamara to Department of the Army for the Army Audit Agency to review all the circumstances surrounding the call-up of two National Guard divisions and the supporting Reserve units, about 2½ years ago. That audit required the Agency to get into all aspects of the call-up starting from the time Mr. Stahr wrote a memorandum to Mr. McNamara telling him of the problems the Army would face in the call-up, to a date in February 1962 when the two divisions were still on active duty. After that special audit, and as a result of an audit at Fort Lee disclosing certain observations on the Fourth Division, the Agency was directed by General Hamlett, who at that time was DCSOPS, to make an audit of all STRAF units with respect to their STRAF requirements.

The most recent directive for that type of audit assignment was with respect to the aviation problems in the Republic of Vietnam. The agency was directed by the Army Chief of Staff to make a complete review of Army aviation in the Far East to include problems of the helicopters in Vietnam together with the related spare-parts and funding problems in CONUS. Adding to these within-house requests, the Agency, as well as the audit activities of the other Military Services, has received directives from the Department of Defense requiring the audit activities of the three Military Services to be broad enough to cover all matters that the General Accounting Office might review, which, as most of you know, cover the waterfront.

Under the expanding requirements, the scope of audit set forth in AR 36-5 is not comparable to the comprehensive scope of audit that we are actually performing today. This AR is presently being revised to broaden and more properly define the scope and responsibilities of the Army Audit Agency.

In addition to audits of military installations and activities, the Agency has the responsibility of auditing all contractors who have

---

*all with the Public Housing Administration; Assistant Director of Internal Auditing, GSA; Chief of Internal Audit, Army Audit Agency; Assistant Chief, U. S. Army Audit Agency for Audit Operations.*

*(The present paper was prepared from the transcription of an oral presentation made at USAMS, Fort Belvoir, Virginia, on 23 January 1964.)*

contracts with the Army wherein cost is a factor in reimbursement for the contractor. In that area we also have the responsibility, when called upon by contracting officers, to review price proposals with respect to proposed contracts that involve negotiations. Under Army regulations a contracting officer is required to call in the Army auditor on a price proposal where competition is nonexistent and where the contract will be in excess of \$200,000. If he does not, he is to document his files as to the reasons.

Organizationally, the U. S. Army Audit Agency is a world-wide organization. The Chief of the Agency is Major General Stanley W. Jones. He reports to the Comptroller of the Army, Lieutenant General Robert Hackett, and has authority for direct dealings with the Assistant Secretary of the Army for Financial Management. The Agency has its headquarters in Washington and maintains 14 operating district offices throughout the world where the actual audit work is performed. Twelve of these district offices are in CONUS and two are overseas, one at Camp Zama, Japan, for all our work in the Far East and one in Paris, France, for the work in Europe and the Near East.

In addition, certain residencies are permanently staffed and maintained at sizeable Army installations, in most cases at the Army Inventory Control Points, and at certain contractors' organizations where the workload is sufficient to justify maintaining a permanent staff. As an example, the Agency has responsibility for all Department of Defense auditing of the Western Electric Company. Permanent audit staffs are maintained at the headquarters of Western Electric in New York and at Winston-Salem.

### *Some Techniques of Internal Auditing*

So much for the organization, now back to some techniques of internal auditing. We approach an internal audit from a threefold point of view. One, the audit of an Army installation as such; two, the audit of an Army-wide function; and three, the audit of a major Army program or command. As an example of the latter, at the present time we are making an audit of the Nike-Hercules weapons system, and of the Army Air Defense Command (ARADCOM).

We learned a lesson a few years ago when we attempted to audit the Army missile program in its entirety. It was a monster too big to come to grips with, so we have since shortened our sights and are now taking a specific program, missile, or weapons system and auditing it from the cradle to the grave or from the drawing board to possession of the item by using units. Auditing of the Nike-Hercules will be done at the Missile Command in Huntsville, at various Army procurement districts, at contractor sites where the Hercules or spare parts

are produced, at Army depots where parts are stored, and at batteries where the Hercules is actually employed. There will be one overall report issued on the total audit, together with, probably, a separate report on ARADCOM, and several other individual reports on various installations.

In a comprehensive audit of that type and all other audits required by AR-36-5, when a finding is developed it is submitted to the appropriate activity chief for his review and comments. We like to get these comments in writing, but sometimes we cannot. We try to resolve any differences of opinion between auditors and operating personnel at the installation level. Since auditors are human, they can be wrong. So discussing at the installation level what appears to be a valid finding, frequently will result in a finding being dropped. If, on the other hand, command is unable to convince us that we are wrong, the finding will be included in the report along with command's observations as to why it does not concur. If command concurs, the report will so state.

The overall draft report usually is submitted to command about 10 days before our normal exit conference with command. At the exit conference we like to receive any observations command has as to the wording or conclusions in the report. If the tonal quality of the report is not good, we want to hear about it. Whatever changes in the report are necessary are made after the exit conference. We then try to issue the report within 30 days after the exit conference. In accordance with the provisions of AR 36-5, the addressee of a report is required to reply to the Adjutant General as to corrective actions proposed to be taken.

Under the contract audit responsibility the bulk of our work is auditing cost-type contracts and incentive-type contracts and giving advice to contracting officers as to the validity of claims submitted by the contractor.

About a year and a half ago we broadened our concept of audits of what we call "major continuity contractors," that is, those contractors who generally are heavily engaged year in and year out in large dollar volume of Defense business. During the year, as we complete audits of various segments of a major contractor's operation, we issue interim reports. Then at the end of the year we issue an overall summary report on the contractor's total operations during the year. The scope of audits of major continuity contractors considerably exceeds the mere verification of costs. Under recent revisions to the Armed Services Procurement Regulation we are concerned with the propriety and reasonableness of charges made against Government contracts. As an example, in decisions to make or buy, we are interested in determining whether making or buying is in the best interest of the Government. In this respect, some two years ago the

General Accounting Office issued a report which was quite critical of a make-or-buy decision made by one of the Services, not the Army. This was a decision to make rather than buy an air-conditioning component for a particular end item. The particular contractor had never manufactured the component before; but, since production facilities were available and he wanted to gain the experience, he decided to make the item. It was determined by the General Accounting Office that this component cost approximately \$2.5 million, but could have been procured by the contractor from a reputable, experienced producer for about \$500,000. This is the type of management decision that the Agency prefers to evaluate before the fact rather than after the fact.

The Agency is also interested in a contractor's recruiting practice, particularly with respect to engineering. We do not contend that auditors are competent to determine how many engineers a contractor needs, but we do contend that auditors are capable of determining whether the contractor actually has a recruitment plan, and whether he knows how many people he needs and where he needs them. The recruitment plan could be a hit-or-miss proposition resulting in the hoarding of technical skills. If so, it does not require a mental giant to make such determination. When we first entered into what might be called the management area of a contractor's operations, contractors did not like it and I can well understand why. We were pointing out shortcomings in efficiency and economy which theretofore had been of little concern, especially to those contractors whose business with the Government was as high as 99 percent of total business, and quite often involved cost-type contracts providing little incentive to be efficient. I think, that these summary reports which require a reply by the contracting officer as to the action he proposes to take on the findings and recommendations are having a healthy effect on contractor operations. I do not mean to say that all contractors are inefficient and uninterested in efficient and economic operations. Many of them are, but with the type of contract that has been prevalent during the past several years, there really has been no incentive for a contractor to cut down on costs or to insure more efficient operations. The present emphasis being given to competitive and incentive-type contracting is a step in the right direction in providing these incentives.

Going back again to Army installation audits, people in the past have often questioned whether an auditor is competent to evaluate the broader aspects of Army operations. We think we are. Through the two-division call-up audit, the STRAF audit, and the Vietnam audit, we think we have proved that we are. Why do we think that we are particularly well qualified? First of all, you have to know what you are auditing, and that is a prerequisite to any audit, whether it

be in the Army or on the outside. Public accounting firms do not assign key people to audit, let's say, an automotive company, unless they have had experience in the automotive industry. In the early days of the Agency's existence we were guilty at times of not knowing what we were auditing, because we had a lot of people who were inexperienced. We were fooled into thinking that just because an individual was an expert accountant or had a CPA certificate, he could audit an Army installation. Too often we were wrong.

### *College Recruitment Program*

In 1954 we started a college recruitment program, visiting the colleges and recruiting a sizeable number of the better college men each year. In recent years we set a goal of approximately 75 to 90, and since 1954 we have hired about 1,200 men off the college campuses. We have a total staff in the Agency today of about 1,800. Approximately 1,450 of these are auditors. Of that number, about 500 are men that we brought into the Agency from colleges. The Army Audit Agency was their first job, and today these men are the backbone of our organization. Most of the lead auditors and the auditors-in-charge are men who came with us through college recruitment programs and they now know the Army pretty well. Out of the original class of 1955, we have today three men who have reached Grade GS-14 and about 25 who are Grade GS-13.

The college recruitment program, together with our own training program, has permitted us to provide people that we feel are capable of doing the sort of work we are required to do. Under our recruitment and training program, we bring the men in from the colleges in July and send them to our district offices. They remain in the districts for about two weeks, getting to know the people for whom they will work. Then they are sent to Indianapolis for a week to get a general orientation on the Army and a little more knowledge of the work we do. After that week they return to their respective districts and go out on their first jobs under competent supervision. At the end of the third month we bring them back to a central point for another one-week formal training program, at which time we start to give them case problems. After that week, they return to the field to resume their work. Intermittent formal training programs are also carried out in the district offices.

At the end of six months, these new men are brought back to a central point for their final formal training; and at the end of that last course we give them a test. Based on the results of the test, the evaluation of the district manager of their on-the-job performance, and the evaluation of their instructors at the three courses, we select what we call the "intern auditor of the year." We bring him into

Washington where General Jones presents him with a certificate and a cash award. We also take him to the Pentagon where he meets General Hackett, the Army Comptroller; Mr. Pratt, the Assistant Secretary for Financial Management; and the director of civilian personnel.

Under the recruitment program we can bring the men in at grade GS-7 if they are in the top 20 percent of their class. If they are not, we can bring them in at grade GS-5. If, after six months, future employment is mutually agreeable, we can promote them from a GS-7 to a GS-9, or from a GS-5 to a GS-7, respectively. It is surprising the high quality of youngster that we get. Some of you may have observed that, although we have hired about 1,200 college graduates over the past eight years, we presently have only about 500 on the rolls. That normally would seem to be a pretty heavy turnover, but in our type of business it is not. The public accounting firms feel that they are doing well if, out of every five men they get from colleges, they have one left at the end of five years.

### *Costs*

A word on what auditing in the Army costs and what the Army gets for the money. The Agency's budget today is about \$20 million. That is a lot of money, so it is fair to ask, what does the Army get for it? From the viewpoint of contract auditing and working with contracting officers, we save \$30 for every \$1 spent on a contract audit. We reduce procurement costs anywhere from \$250 million to \$350 million a year. Viewed from the side of auditing Army installations, we conservatively estimate savings of from \$15 to \$20 million a year; however, to me the dollar savings are not as important as the intangible benefits of the contributions we make to improvements in systems and operations. The important thing to me is that we believe we are helping the Army do a better job by pointing out areas susceptible of management improvements and deficiencies that could be critical to the Army.

Let me refer to the Vietnam audit report. If that report had been issued by the General Accounting Office, all you-know-what might have broken loose. As a matter of fact, GAO did get into the Vietnam problem after we had got in, but we got our report out before they did. They came out with a draft report only about three months ago, but the report had very little in it of any significance. Mr. Vance read our report and General Hamlett sent it out over his own signature to every major commander in the Army, pointing out that the report emphasized some problems in aviation supply and suggesting that they be looked into and corrective measures taken.

Let me emphasize that nobody in the Army was criticized for any of the problems in Vietnam. We think that the Army did a tremendous job in Vietnam under the adverse circumstances. It was through blood, sweat, and tears that the Army did the fine job that it was sent over to do. But in our report we not only called attention to the deficiencies and the problems, but also highlighted some of the circumstances that occasioned these problems. Some of our counterparts who also have a responsibility for reviewing Army operations are not always so interested in portraying all of the circumstances, good and bad, surrounding a given situation.

#### *Relations with IG*

One word on our relationship with the Inspector General. It has often been asked whether we duplicate the work of the IG. I think that the IG and the Agency agree we do not. (As a matter of fact, the IG has just completed its annual inspection of our headquarters.) I think there could be duplication, however, because the charter of the IG authorizes delving into almost anything in the Army, whereas our charter is almost that broad also.

Instead of duplication, I like to think we complement each other. As an example of what I mean, it was the IG who drew our attention to the Vietnam situation. Since we have a close working relationship with the IG, I think there is no real duplication of effort.

In conclusion, may I say that we in the Agency honestly believe that we are recognized to be part of the Army team, that we do help the Army to do a better job, that we do in some measure help the Army avoid bad publicity, and that the money which the Army makes available to us is money well spent and returned manyfold.

## SPEAKER INDEX TO PART 1\*

- BEACH, Dwight E., Lt. Gen.,** The Combat Developments Command Program, pp. 121-143.
- BESSON, Frank S., Jr., Gen.,** Army Materiel Command, pp. 105-120.
- BOGART, F. A., Lt. Gen.,** Management in the U. S. Air Force, pp. 46-64.
- BUNKER, William B., Maj. Gen.,** Control of a Major Enterprise, pp. 173-189.
- CRITZ, Harry H., Maj. Gen.,** The Challenge of Post Management, pp. 211-230.
- EIFLER, C. W., Brig. Gen.,** Project Management, pp. 256-273.
- HACKETT, Robert, Lt. Gen.,** Some Remarks on Comptrollership in Today's Army, pp. 25-45.
- HORWITZ, Solis, Hon.,** The Management Concept of Mr. Robert S. McNamara, The Secretary of Defense, pp. 1-24.
- JENKINS, James C., Mr.,** Concepts of the Command Channel Stock Fund, pp. 90-101.
- KYSER, Robert C., Maj. Gen.,** Operations of the Supply and Maintenance Command, pp. 231-242.
- LAUX, Ray J., Maj. Gen.,** Progress of the Defense Supply Agency, pp. 144-157.
- LYNDE, Nelson M., Jr., Maj. Gen.,** Some Remarks on Management at the Army Weapons Command, pp. 206-210.
- RICH, Charles W. G., Maj. Gen.,** Some Problems in Managing a Military Installation, pp. 190-205.
- ROBBINS, James A., Mr.,** Internal Auditing and the Army Audit Agency, pp. 274-281.
- SHEA, Leonard C., Brig. Gen.,** Planning, Programing, and Budgeting at Department of Army Headquarters, pp. 65-89.
- SIBLEY, Alden K., Maj. Gen.,** The Mobility Environment, pp. 158-172.
- SUTHERLAND, James W., Jr., Maj. Gen.,** Managing the Test and Evaluation Command, pp. 243-255.

---

\*This Speaker Index lists only those speakers with presentations appearing in *Part 1*. For overall list of speakers with speeches appearing in all three parts of *Vol. IX*, please see Speaker Index at end of *Part 3*.

UNCLASSIFIED

Security Classification

DOCUMENT CONTROL DATA - R & D		
<i>(Security classification of title, body of abstract and indexing annotation must be entered when the overall report is classified.)</i>		
1. ORIGINATING ACTIVITY (Corporate author) U. S. ARMY MANAGEMENT SCHOOL FORT BELVOIR, VIRGINIA 22060		20. REPORT SECURITY CLASSIFICATION UNCLASSIFIED
		21. GROUP N/A
2. REPORT TITLE ARMY MANAGEMENT VIEWS, VOL IX, Book 1		
3. DESCRIPTIVE NOTES (Type of report and inclusive dates)		
4. AUTHOR(S) (First name, middle initial, last name) ARMY MANAGEMENT SCHOOL		
5. REPORT DATE 1964	10. TOTAL NO. OF PAGES 281	15. NO. OF REFS N/A
6a. CONTRACT OR GRANT NO.	6b. ORIGINATOR'S REPORT NUMBER(S) VOL. IX, BOOK 1	
6. PROJECT NO N/A	6c. OTHER REPORT NUM(S) (Any other numbers that may be assigned this report) None	
7. DISTRIBUTION STATEMENT (Statement No. 3) (Unclassified Document) Each transmittal outside agencies of U.S. Government must have prior approval of Deputy Commandant U.S. Army Management School, Ft Belvoir, Va 22060.		
8. SUPPLEMENTARY NOTES N/A	9. SPONSORING/MONITORING AGENCY NAME(S) AND ADDRESS(ES) U. S. ARMY MANAGEMENT SCHOOL FORT BELVOIR, VIRGINIA 22060	
13. ABSTRACT Brief articles on top-level Army management; management of Army commands		

DD FORM 1473

UNCLASSIFIED

Security Classification

KEY WORDS	LINK A		LINK B		LINK C	
	ROLE	WT	ROLE	WT	ROLE	WT
ARMY MANAGEMENT SCHOOL MANAGEMENT IN THE ARMY ROBERT S. McNAMARA COMPTROLLERSHIP IN THE ARMY INSTALLATION MANAGEMENT ARMY FIELD COMMAND MANAGEMENT						