

UNCLASSIFIED

AD NUMBER
AD835158
NEW LIMITATION CHANGE
TO Approved for public release, distribution unlimited
FROM Distribution authorized to U.S. Gov't. agencies and their contractors; Critical Technology; 03 MAR 1966. Other requests shall be referred to Department of the Army, Fort Detrick, Attn: Technical Releasing Branch, Frederick, MD 21701.
AUTHORITY
SMUFD, D/A ltr, 14 Feb 1972

THIS PAGE IS UNCLASSIFIED

AD835158

1620

TRANSLATION NO. ~~██████████~~

DATE: 13 MARCH 1966

DDC AVAILABILITY NOTICE

Reproduction of this publication in whole or in part is prohibited. However, DDC is authorized to reproduce the publication for United States Government purposes.

STATEMENT #2 UNCLASSIFIED

This document is subject to special export controls and each transmittal to foreign governments or foreign nationals may be made only with prior approval of -----

DEPARTMENT OF THE ARMY  
Fort Detrick  
Frederick, Maryland 21701

*attn: Tech. Admin. Br.*

DDC

JUL 15 1968

████████████████████  
████████████████████

# DISCLAIMER NOTICE

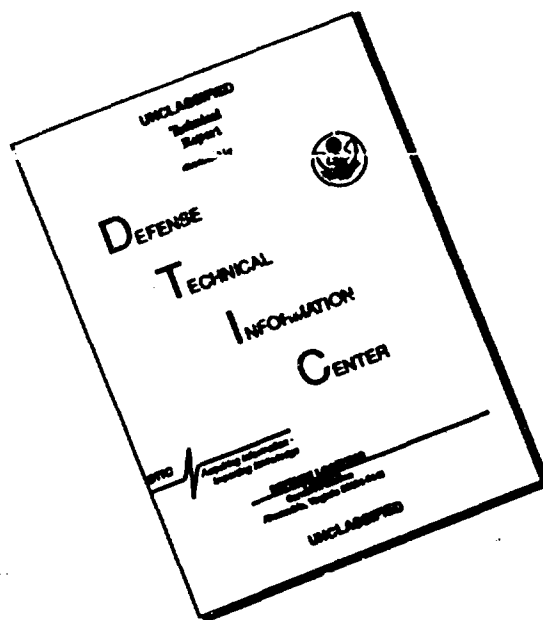

**THIS DOCUMENT IS BEST QUALITY AVAILABLE. THE COPY FURNISHED TO DTIC CONTAINED A SIGNIFICANT NUMBER OF PAGES WHICH DO NOT REPRODUCE LEGIBLY.**

HISTOCHEMICAL STUDIES ON THE LESIONS OF RICE BLAST  
CAUSED BY PIRICULARIA ORYZAE VAC. PART I. SOME  
OBSERVATIONS ON THE SPORULATIONS ON LESIONS OF  
DIFFERENT TYPES OCCURRING ON LEAVES OF THE SAME VARIETY.

Annals of the Phytopathological  
Society of Japan, 17, 1(1952).

Sakae Toyoda and  
Naoji Suzuki, National  
Institute of Agricultural  
Sciences, Ministry of  
Agriculture and Forestry.

1. Introduction

The authors and Mr. Doi undertook a histochemical study of the changes which occur within the cells and tissues of aquatic rice plants infected with rice blast disease caused by *Piricularia oryzae* CAV. with the intent of acquiring some clue which would help clarify the mechanism and action of resistance.

As a first step in this investigation, we took varieties of rice susceptible to the disease, also varieties which showed a wide range of susceptibility depending on the conditions, classified the various lesions forming on the leaves by means of the external appearance of these lesions, adopted the sporulation intensity of the lesions as an index of the resistivity of the tissue (Fisher and Gäumann<sup>(1)</sup>), and attempted to determine a relation between the external appearance of the lesions and the resistivity of the tissue, the results of such an investigation being hereby reported in this paper.

In the preparation of this report, the authors are indebted to Hideo Mukai, chief of the Pathology Section of the Institute of Agricultural Sciences, and also Prof. Hideoumi Asuyama of Tokyo University for their timely criticism and advice.

2. Materials and method

The rice plant leaves infected with rice blast disease used for this study came mainly from naturally infected plants of the wetland variety Saitama mochigome (Glutinous rice) No.10 grown on farm plots in the vicinity of the town of Urayasu in Chiba Prefecture, the specimens being collected during the period from September 1 to 15, 1951. Individual lesions on these infected leaves were inspected for prior conidium formation, and where conidia had already formed, the latter were washed off and the specimen then placed, as shown in Figure 1, in a damp chamber for microscopic observation of the process of sporulation.

The damp chamber consisted of two glass plates, each 8cm x 5cm in size, separated 3mm by means of four glass strips, the pieces held together with paraffin, and a hole 8mm in diameter in the center of the upper plate.

The leaf sections were folded through the lesions, the sections then sandwiched between several layers of wet filter paper with the bent edge positioned so as to be centered in the damp chamber. The remainder of the space in the damp chamber was filled with wet filter paper, leaving only a hole in the center for the passage of light. This assembly was then fixed on the microscope stand, and the conidiophore and conidium formation emerging horizontally from the exposed bent leaf edge was studied. No cover glass was used, in other words, more natural conditions were approached by means of the hole in the upper glass plate and the exposure of the specimen to the air. Another advantage of this arrangement was that there was no hindrance to visual observation which might normally arise from water droplets adhering to a cover glass.

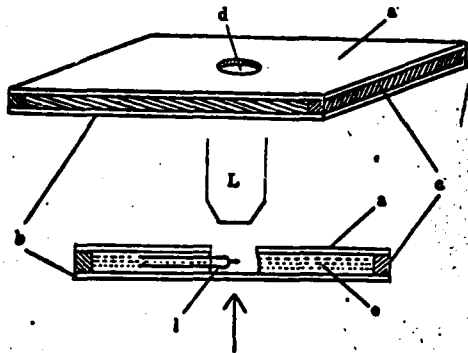

Figure 1. Moist chamber for the continuous observation of conidium formation.

- a: Upper glass plate.
- b: Lower glass plate.
- c: Separating glass strip.
- d: Small hole.
- e: Filter paper.
- l: Lesion on leaf.
- L: Objective lens.

### 3. Classification by external appearance of lesions on leaves of the same plant variety.

The various types of lesions occurring by natural infection on the leaves of the rice plant, variety Saitama Mochigome No.10, were sorted into five classes as shown in Figure 2.

All of the different types of lesions shown in Figure 2 have appeared on the leaves of plant varieties known to be susceptible to the disease, and some distinction must be made with respect to the infectious type based on genetic susceptibility or resistivity. If we consider the different types of lesions shown in the figure according to Ono's classification of lesions<sup>(2)</sup>,

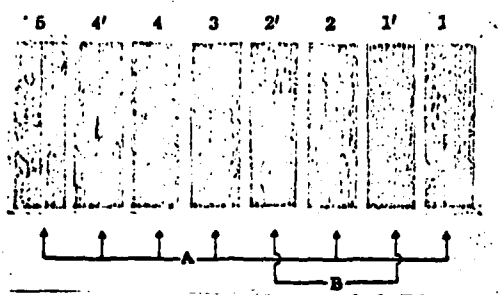

Figure 2. Various lesions occurring on leaves of Saitama mochigome No.10 variety rice plants.

A: Collected September 1; specimens 1 and 2 are lower leaves, coloration yellowish-green.

B: Specimen collected September 10; color of leaf dark green with considerable browning.

1. Brown spot type.
- 1'. Chronic type; lesion larger than in type 1, consisting only of brown part.
2. Chronic type; center greyish-white, circumference brown.
- 2'. Chronic type; brown perimeter further surrounded by yellow circumference.
3. Acute type; center greyish-green, prominent browning of circumference, further surrounded by yellow section.
4. Acute type; center greyish-green, perimeter starting to turn brown with prominent yellow circumference.
- 4'. Acute type; combination of types 4 and 5.
5. Acute type; center greyish-green, perimeter has not browned.

Of the above types of lesions, types 5, 4, 3, and 2' represent a development of type 5. Type 5 is peculiar to the lower leaves which have turned a yellowish-green, and this seems to be the result of resistivity accompanying aging of the leaf. Type 2 is probably an intermediate type, somewhere between a type 1 and a development of type 3.

The lesions do not always develop in the sequence of types 5 → 4 → 3 → 2'; depending on the conditions, there can be a rapid progression from type 5 to type 3.

The above results show that the development of a lesion generally consists first of the occurrence of a greyish-green section, followed by yellowing of the edges of the initial patch, then browning of the boundary between the green and the yellow sections, the browning being an indication of weakening of the infection.

4. Order of conidium formation on lesions of types 3 and 4.

Lesions of types 3 and 4 in Figure 2 are representative of susceptibility, and the sporulation observed in these cases can be considered to be typical. We therefore selected lesions of these types for observation in the moist chamber with lapse-time microphotographs being taken of conidium formation, typical examples being shown in Figure 3.

In Figure 3 can be seen the formation of three conidia atop a single conidiophore. Conidia are generally formed in this manner with often six to seven conidia being formed. During some 24-hours of continuous observation, no detachment of spores were observed.

As a result of observation of many examples, including the specimen shown in Figure 3, it was found that the first conidium formed in about forty minutes, while the second conidium formed soon afterwards, i.e., in roughly an hour.

A dense growth of conidiophores was observed roughly ten hours after the lesions were put into the moist chamber.

The progress of conidia formation coincided roughly with that observed by Henry and his coworkers<sup>(3)</sup>, the mode of branching being sympodial.

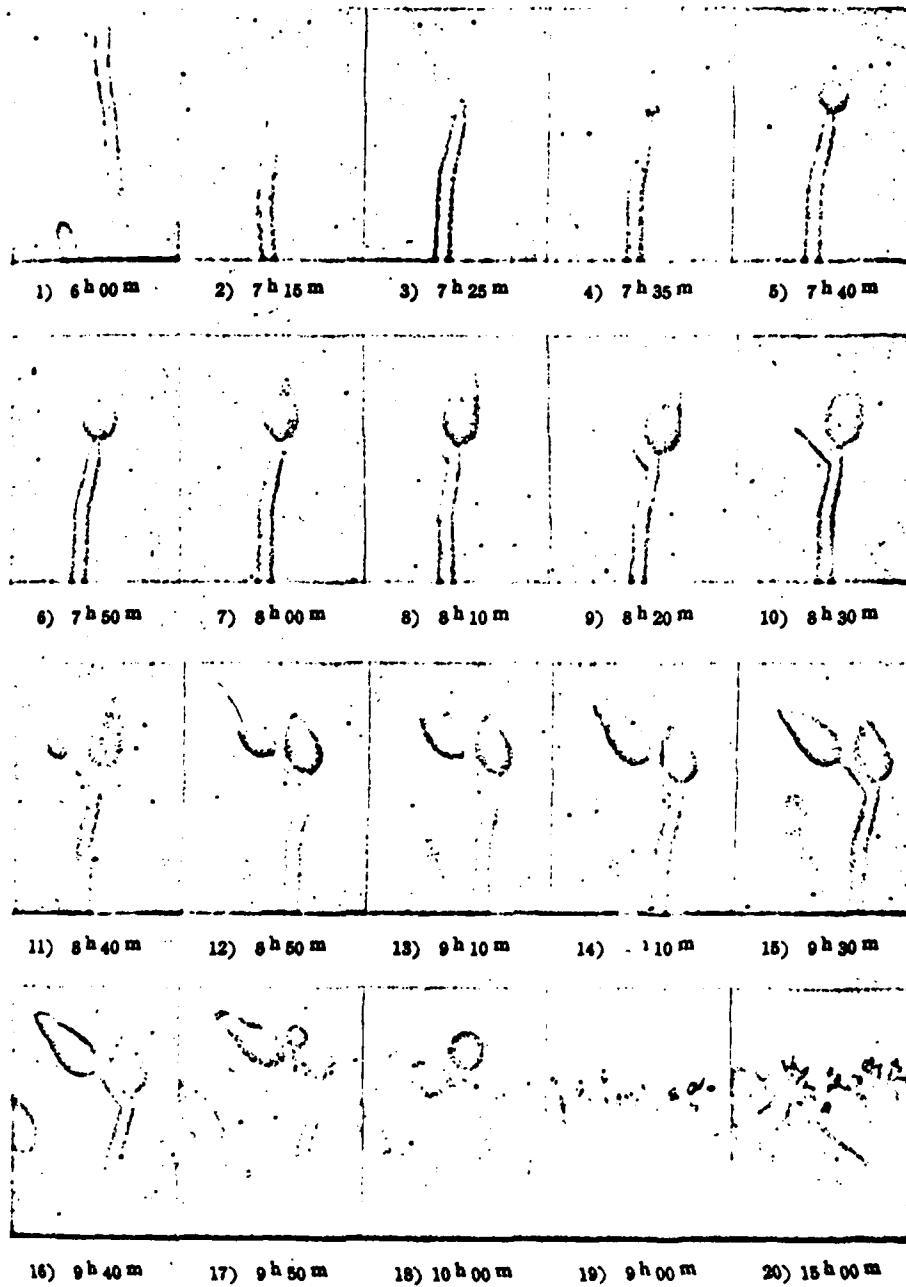

Figure 3. Order of conidium formation on lesions.

(1) After placement of the lesion specimen in the moist chamber, a conidiophore emerged in about 4 hours, this further developing in 6 hours to the point shown in the photograph.

(2) Photograph of a conidiophore just before the beginning of conidium formation. A small spherically shaped body, strongly refracting light, can be seen in the protoplasm at the apex of the conidiophore.

(3) The small sphere, which had developed in the head of the conidiophore, grows out of the apex to become a sterigmata.

(4) The tip of the sterigmata develops into a small spherical body strongly refracting light.

(5) The small spherical body rapidly grows to twice its size in five minutes.

(6) The body grows in length as well as in size to become ellipsoidal. Close observation shows the existence of a small spherical body in the protoplasm at the tip which strongly refracts light.

(7) The small spherical body, which strongly refracts light, grows in size and elongates, and the conidium becomes egg-shaped.

(8) The conidium becomes completely shaped with the formation of a septum, and simultaneously just below the point of attachment of the first conidium, the beginning of another sterigmata is observed.

(9) This protrusion gradually grows in length.

(10) From the tip of this conidiophore, a small protrusion develops, similar to the situation in the formation of the first conidium.

(11) The end of the protrusion becomes gradually larger and into a spherical shape.

(12) The spherical body enlarges into an ellipsoidal shape, and simultaneously, the angle of attachment of the first conidium changes. This change in angle occurs instantaneously forward, backwards, or in a direction opposite to that of the second conidium, and it is meant to ease the spatial conditions for spore formation.

(13) The apex of the sphere elongates so that the conidium becomes egg-shaped, similar to the situation of formation of the first spore.

(14) The tip of the body further elongates, a septum is formed, and the second conidium is thus completed.

(15) Immediately below the point of attachment of the second conidium to its conidiophore, a small protrusion develops.

(16) This protrusion gradually grows in length.

(17) At the end of this growing new conidiophore, a small spherical body, which is to become the third conidium, now forms.

(18) This spherical body grows in size, while simultaneously there is a sudden change in the angle of attachment of the second conidium.

(19) The condition of sporulation 9 hours after beginning of the experiment.

(20) The situation of sporulation 15 hours after the start of the experiment.

#### 5. Abnormal conidia formation.

During the observations, there were cases where incomplete conidia were formed chained together in Alternaria form. Same as in the case of normal conidium formation, a small protrusion first developed at the tip of the conidiophore, this protrusion gradually developing in size, but before this developed into a complete conidium, a second protrusion formed at the tip of the incomplete conidium, this second protrusion then developing into a complete conidium.

#### 6. Comparison of conidial development between different type lesions.

In Figure 4 are shown the results of observation at hourly intervals of conidial formation from the various type lesions, described in Figure 2, in a moist chamber.

It is seen that conidiophores were observed earliest with Type 4 some 5 hours after the lesions were put into the moist chamber, followed by conidiophore development in Types 5 and 3 at 6 hours, Type 2 much later at 11 hours, while there was no conidiophore development in the case of Type 1.

Conidia formation was earliest with Type 4 at 8 hours, followed by Type 5 at 9 hours, Type 3 at 11 hours, and with Type 2 there was sparse development after 15 hours.

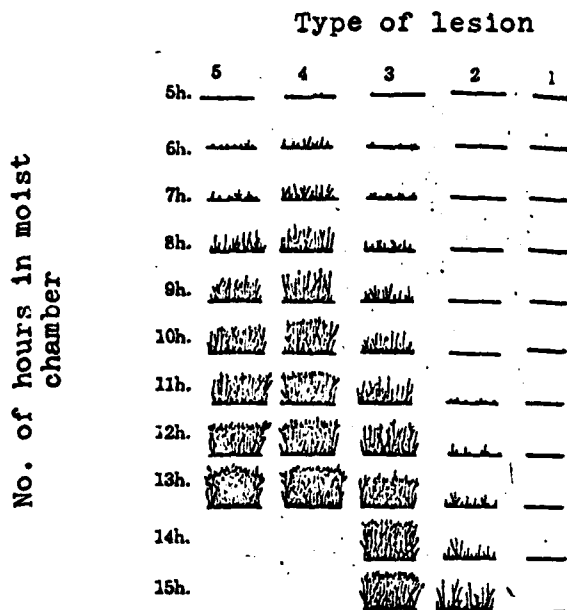

Figure 4. Comparison of conidial development between different type lesions.

With respect to fasciculation of the conidiophores, development was most rapid and dense with Type 4, followed by Type 5, and with Type 3, occurring some 3 to 4 hours later.

These observations showed that sporulation intensity was greatest with Type 4, followed by Type 5, then with Type 3 having less intensity, and with Type 2 being very weak.

In the case of Type 1, there was no sporulation.

In Table 1 are indicated the location of conidia formation on lesions of different types.

Lesion Type	Location of conidia formation on lesions of different types.		
	Central part	Browned part	Yellowish part
5	++++	Had not turned brown.	
4	++++	-	-
3	+++	+	+
2	-	+	Weak yellowing
1	-	-	No yellowing.

As can be seen from the above table, there is less conidia formation in the central part of the conidiophore with progression to Types 3 and 2, or that is, there is more sporulation in the brownish perimeter section, this again occurring with decreasing intensity.

## 7. Discussion.

With respect to the varieties of wetland rice with low resistance to rice blast disease, the authors had observed that the appearance of the lesions on the leaves of these plants varied with the conditions of fertilization, sun exposure, the stage of growth, and phyllotaxy. Collecting as many samples of lesions as possible, the authors were able to classify these lesions, according to their external appearance, into five groups. With Type 1, there was no further development of the lesions and there was also no sporulation, which clearly indicated that such a result was due to resistance to the disease inherent in this variety. With Types 2' through 5, there was increasingly more development of the lesion with time and type, this result again reflecting susceptibility of the strains involved to the disease.

With respect to a susceptible leaf, it was observed that, with progression of the lesion, there was the development of local resistance within parts of the lesion. With Types 4, 3, and 2 in this order, the buildup of resistance to spore formation can be observed.

The Type 5 lesion need not necessarily develop in the order of Types 4, 3, and 2'. For instance if a plant has been shaded for several days, inoculated with the disease and Type 5 lesions allowed to develop, after which the leaf is then exposed to the sun, there is a rapid change to Type 3.

With respect to the various apparent characteristics of the various types of lesions, Type 1 lesions consist of brown spots, while Type 5 are infiltrating greyish-green lesions. With the transition from Type 5 to Types 4, 3, and 2, the browning of the perimeter of the central greyish-green mass becomes prominent.

These observations show that with varieties where the susceptibility or resistivity easily changes with the environmental condition, then with host plants with resistant tissue, browning of the lesion occurs fairly rapidly with invasion of the parasite, and with susceptible varieties, there is the local development of resistance accompanying browning within the diseased tissue.

## 8. Summary.

(1) A device was designed to continuously observe conidia formation in rice blast disease lesions. The procedure of spore formation was clarified by means of lapse-time micro-photography.

(2) The lesions forming on the leaves of a Saitama mochigome No.10 variety of rice were classified into five types, according to the external appearance of the lesions, illustrations being given. The lesions observed with Norin No.3 and No.1 varieties of rice also fall within one or the other of the types described here.

(3) With the Type 3 or 4 lesions most commonly seen in the case of infection of the susceptible varieties, conidiophores developed in about 5 hours in the moist chamber, with conidia formation starting in about 7 to 8 hours. Following the development of a sterigmata at the tip of the conidiophore, the conidium is completely formed in about 40 minutes. The second conidium is completed soon thereafter in about an hour. There are usually about six to seven conidia on a single conidiophore. After 13 to 15 hours, fasciculation of the conidiophores reached its maximum. During 24 hours of continuous observation, no detachment of spores was observed. The mode of branching of the conidiophore was sympodial.

(4) With the Type 1 lesion, there was no conidium formation. With Types 2 through 5, there was conidia formation in varying degree, the intensity of sporulation being in the order  $5 < 4 > 3 > 2$ . This means that with the development of the lesion, there also develops locally in the infected tissue an increase in resistance to the disease.

(5) The browning on the perimeter of the lesion is believed to be an important factor in the development of resistance to spore formation.

## References

- (1) Fischer, E.u.Gäumann, E.: Biologie der pflanzenbewohnenden parasitischen Pilze.(1929)
- (2) Kosaburo Ono: Annals Phytopathol.Soc.Japan, 15, 43 (1950).
- (3) Henry, B.W., and Anderson, A.L.: Phytopath. 38, 260 (1948).

### Resume

Leaf lesions of blast, caused by *Piricularia oryzae*, on a susceptible variety of rice were grouped into five classes according to the degree of brown coloration and size of the lesions (see Fig.2).

Sporulation process on a single lesion of class 4 was observed and microphotographed at definite intervals. After a lesion was placed in a moist chamber, specially designed for the present purpose, as shown in Figure 1, a conidiophore began to emerge in about six hours, and produced the first conidium at its apex one hour later, which reached its full size in 40 minutes. Soon after, a branch developed from the conidiophore just below the point of attachment of the first conidium, and the second conidium was formed at its apex.

In the same manner, process of conidial formation continued to form 7 to 9 conidia on one conidiophore, each being formed at about an hour's interval. The mode of branching of the conidiophore is sympodial in accord with the observations of Henry et al (1948).

Sporulation intensities of lesions of different classes were compared. Sporulation was most rapid and abundant on 4, less on 5 and 3, and very scarce in 2, whereas entirely absent on 1. It seems likely that the browning of the lesion could retard the spread and normal growth of the mycelia in the host tissue, and consequently, the sporulation on the lesion.  
(National Institute of Agricultural Sciences)