

UNCLASSIFIED

AD NUMBER
AD841125
NEW LIMITATION CHANGE
TO Approved for public release, distribution unlimited
FROM Distribution authorized to U.S. Gov't. agencies only; Administrative/Operational Use; SEP 1968. Other requests shall be referred to Commander, Naval Civil Engineering Laboratory, Port Hueneme, CA 93041.
AUTHORITY
USNECL ltr, 25 Oct 1968

THIS PAGE IS UNCLASSIFIED

AD 841125 L

**R 595**

Technical Report

**MULTISTAGE FLASH DESALINATION UNIT  
UTILIZING DIESEL GENERATOR WASTE HEAT**

September 1968

DDC  
RECORDED  
OCT 15 1968  
B

NAVAL FACILITIES ENGINEERING COMMAND



NAVAL CIVIL ENGINEERING LABORATORY

Port Hueneme, California

Each transmittal of this document outside the agencies of the U. S. Government must have prior approval of the Naval Civil Engineering Laboratory.

# MULTISTAGE FLASH DESALINATION UNIT UTILIZING DIESEL GENERATOR WASTE HEAT

Technical Report R-595

Y-F015-11-04-611

by

J. S. Williams and A. S. Hodgson, Ph D

## ABSTRACT

A multistage flash evaporator utilizing diesel generator waste heat has been developed for desalination. After preliminary experimental studies, a unit was constructed to operate continuously from a variable heat supply and produce between 2,500 and 6,000 gpd of freshwater. Interstage brine transfer is automatically regulated by level controllers in each stage, thus eliminating the need for manual control of the unit as the generator load and hence heat output varies. All-aluminum construction has reduced corrosion, and the unit has performed satisfactorily during tests. Typical experimental data is included.

CONVERSION NO.		
CFSTI	WHITE SECTION	<input type="checkbox"/>
OC	DIFF SECTION	<input checked="" type="checkbox"/>
ANNOUNCED		<input type="checkbox"/>
CLASSIFICATION		
BY		
DISTRIBUTION AVAILABILITY CODES		
DIST.	AVAIL.	and/or SPECIAL
3		

Each transmittal of this document outside the agencies of the U.S. Government must have prior approval of the Naval Civil Engineering Laboratory.

## CONTENTS

	page
INTRODUCTION . . . . .	1
Waste Heat as an Energy Source . . . . .	1
Multistage Flash Distillation Utilizing Waste Heat . . . . .	2
EVAPORATOR DEVELOPMENT . . . . .	3
MULTISTAGE FLASH EVAPORATOR . . . . .	5
OPERATION AND TESTING . . . . .	7
FINDINGS . . . . .	11
RECOMMENDATION . . . . .	11
APPENDIX—Experimental Data for Multistage Flash Evaporator . . . . .	12
REFERENCES. . . . .	20
DISTRIBUTION LIST . . . . .	21

## INTRODUCTION

For the production of potable water from seawater, the Naval Shore Establishment has used vapor compression distillation units primarily developed during World War II. The equipment was designed to provide a portable, self-sufficient machine to supply drinking water to forces immediately after establishing a beachhead. It is admirably suited to this purpose, and to date no satisfactory substitute has been found. Consequently, with few exceptions, desalination plants at advanced bases have been equipped with batteries of these relatively small, combat-size units. These units were not designed for this sort of application, and consequently maintenance and logistics problems have been magnified.

Study of the relatively permanent advanced base utility system reveals a disturbing failure to use the waste heat from available energy sources. This failure is understandable when it is recognized that the major emphasis has always been placed in the Military Readiness Program on the requirement for independent systems. The recent trend towards the creation of more and more semipermanent shore facilities, offers the opportunity of demonstrating the feasibility of energy conservation by integrating power generation and water desalination into one system. This report covers work done to develop a desalination system utilizing waste heat from a diesel electric generator.

### Waste Heat as an Energy Source

In any practical power system there is a portion of the energy input which is not recoverable as useful work; in many cases this energy is discarded as waste heat. The efficiency of the system is directly proportional to the heat that is recovered. A comparison may be made between a simple packaged fire tube boiler and a complex power plant boiler with numerous heat exchangers and economizers. Very little heat is lost in the latter, and any significant external demand for heat from this plant would reduce the power output. On the other hand, utilizing the stack gas heat from the small boiler would improve its overall efficiency.

The Navy relies almost entirely on diesel electric generator plants at all the outlying bases. The internal combustion engine is an inefficient device, and not more than 40% of the input energy is converted into useful work, the

remaining energy being lost in the cooling water, exhaust system, and as radiation. Much of this waste heat is recoverable by relatively simple means, and designers and planners should recognize the potential of utilizing this energy by locating facilities requiring heat nearby. Such facilities as laundries, distillation plants, air conditioning units and space heating should be considered as opportunities for the use of waste heat.

Desalination by multistage flash distillation utilizing diesel engine waste heat is the subject of interest in this instance. Design criteria and cost figures for this type of equipment have been published.<sup>1</sup>

### **Multistage Flash Distillation Utilizing Waste Heat**

To prove the feasibility of producing potable water from seawater utilizing diesel generator waste heat, a series of tests have been conducted at NCEL over a number of years.

In 1963 a 24-stage flash evaporator was developed and evaluated.<sup>2</sup> The unit was designed to produce 200 gal/hr when utilizing waste heat from a 60-kw diesel generator. The operation of the system proved satisfactory in most respects, and to complete the evaluation the unit was shipped to the Coast Guard at Marcus Island, where it was installed in the power house.<sup>3</sup>

Reasonable success was achieved with this prototype unit under field testing, although it became apparent that design improvements were required for completely satisfactory operation. Due to design restrictions in the heat acquisition system at Marcus Island, both the total heat available and the maximum brine temperature were much lower than during the previous tests at NCEL. The fact that the overall pressure difference across the evaporator was insufficient to force the water all the way through the unit led to considerable difficulty in operating the unit satisfactorily. Flooding in the lower pressure stages resulted in brine carryover and product contamination. Some improvement was obtained by eliminating stages, but it was evident that modifications were required if a multistage flash evaporator was to be used under varying conditions of heat input and brine temperature limits. The results of the field test proved the practicality of the concept and also showed that the flash evaporator required no additional personnel to operate it, minor adjustments and hourly readings being made by the man on watch in the power house.

This report covers the work done to develop a multistage flash evaporator incorporating design improvements for satisfactory operation. The objective has been specifically to develop a reliable unit to produce 6,000 gpd of freshwater with waste heat available from diesel generators having capacities ranging from 60 kw to 150 kw. The unit must be capable

of operating continuously on variable heat input without manual control. Additional features of easy maintenance in the field and ease of transportation were also considered.

## EVAPORATOR DEVELOPMENT

A study was initiated to determine the best approach to designing a multistage flash evaporator that would operate satisfactorily over a wide range of heat input without manual adjustment. A design optimization study<sup>4</sup> was undertaken to provide guidelines for evaporator development. From previous experience, it was apparent that variable flow through the flashing chambers would be necessary for the system to operate within a constant temperature range. Initially, it was decided to establish a fixed temperature at the brine heater outlet. This fixed temperature could be preset at different values depending upon circumstances, but once set, would not be changed during operation. For example, with a heat source at 215°F, a brine heater temperature of 190°F is possible, or with a heat source at 190°F, the brine heater temperature would be about 165°F. It was first decided that aluminum should be used for the construction of the unit because its resistance to corrosion from brine is superior to that of steel; another advantage of aluminum is that it is lighter and less expensive than copper alloy materials. In order to test components of the control system, a small preliminary eight-stage experimental flash evaporator was constructed in the Laboratory shops. The design capacity of this preliminary unit was approximately 5,000 gpd when a heat source providing 600,000 Btu/hr was used. To accelerate fabrication and provide easy modification capability of this unit, 10-gage steel sheet was used for shell material and 3/8-inch (OD) admiralty metal tubes was used in the condensing section. Each stage had about 25 ft<sup>2</sup> of heat transfer surface furnished by 60 tubes 6 feet long. The unit is shown in Figure 1.

A simple, reliable method of variable flow control through the flashing chambers was required. An attempt was made to use water legs of varying length in the evaporator; these would have no moving parts and the static pressure of the water in the legs was to maintain a fixed pressure-temperature relationship in the unit. However, it was found that the water in the legs flashed to steam, resulting in the loss of static head and consequent flooding and lack of control. This method was discarded, and a search was undertaken for a more suitable control mechanism.



Figure 1. Prototype multistage flash evaporator.

The interstage brine passage permits the flow of brine and prevents the passage of vapor from one stage to the next. A steam trap similar to those used on condensate lines was thought of as a possible means of control. Commercially available equipment is designed for much higher pressures than those encountered in this application, is high priced, and does not have sufficient capacity. In an effort to overcome these problems, it was decided to develop a suitable control mechanism at the Laboratory. After several unsuccessful attempts to utilize simple floats, this approach was abandoned. Although floats are theoretically suitable, the large size required made these devices impractical.

At this time a mathematical model of a multistage flash desalination process was developed and a computer study was carried out to ensure that automatic control of interstage brine transfer was a practical approach for satisfactory operation with a variable heat input to the system.<sup>5</sup> It was concluded that a level controller in each stage was the best means for accomplishing the desired results; in order to incorporate a suitable size of valve, it was decided to use a double-ported valve actuated by a float on a lever arm. This valve was to be located on a well in the bottom of each

evaporator stage. The above experiments were all carried out on the experimental steel evaporator, and the data were used in the computer program. It was not feasible to further modify the steel unit, add the well necessary for the new valve, and fully test the control system. During the latter part of the test program on the steel evaporator, construction of the aluminum unit was started. The wells for installation of the control valves were included, and testing continued with the aluminum unit.

A commercial double-ported drainer valve was tested with some success. However, the largest size made would not handle the required flow at low pressure differences and, therefore, had to be abandoned.

A similar valve was fabricated at the Laboratory for this present application (Figure 2). The valve bodies were constructed of 3-inch aluminum pipe tees.

Interstage distillate control is accomplished with the float valve shown disassembled in Figure 3. These valves are contained in the cylindrical aluminum pots, which may be seen on the side of the evaporator in Figure 4.

The evaporator was found to perform well with these valves installed. Good results were obtained with flow rates up to 40 gpm and pressure differences as low as 0.1 psi.

## MULTISTAGE FLASH EVAPORATOR

The basic principle of operation conforms to standard multistage flash distillation procedures and a flow diagram of the unit is shown in Figure 5. Seawater enters the system through a motor valve which is connected to a temperature sensor installed in the feed line to the first stage of the evaporator at the brine heater outlet. A preset, constant temperature at the brine heater outlet is, therefore, established. The feed passes through a pair of parallel ion traps containing expanded aluminum and into the condenser of the eighth stage of the evaporator. After passing through the condensing section of each stage, the hot feed goes through the brine heater, which consists of a heat exchanger supplied with low pressure steam on the experimental unit. The feed enters the flash chambers, control being established by the float valves installed in the wells below each chamber. Product water is removed from each stage at a rate controlled by the float valves. A schematic diagram of the control system is shown in Figure 6. Waste brine is removed by a pump and the rate is controlled by a hydraulic motor valve actuated by a pilot float valve connected to the eighth stage brine well. The vacuum system consists of three water eductors operating on seawater. Vacuum lines are connected to the first, fifth, and eighth stages, diaphragm valves being used for control. Interstage orifices permit

further control of pressure. Vacuum sealing of the entire evaporator is essential, and noncondensable gases are vented through condenser and vacuum pump.

The entire unit is constructed of aluminum and is illustrated in Figure 4. The main structure is made of 1/4-inch aluminum plate, with each condensing section containing 63 aluminum 3/8-inch (OD) tubes attached to 3/8-inch-thick tube plates. The tubes are 40 inches long and are laid out on a 5/8 x 5/8-inch triangular pitch; each stage has 20.6 ft<sup>2</sup> of heat transfer area. A double set of condenser tubes is shown in Figure 7.

The evaporator itself is 3 feet 8 inches x 9 feet in plan and 4 feet high. The volume of the complete test unit including the vacuum system, pumps, etc., is approximately 420 ft<sup>3</sup>. It would be anticipated that a production unit would occupy about 350 ft<sup>3</sup>.

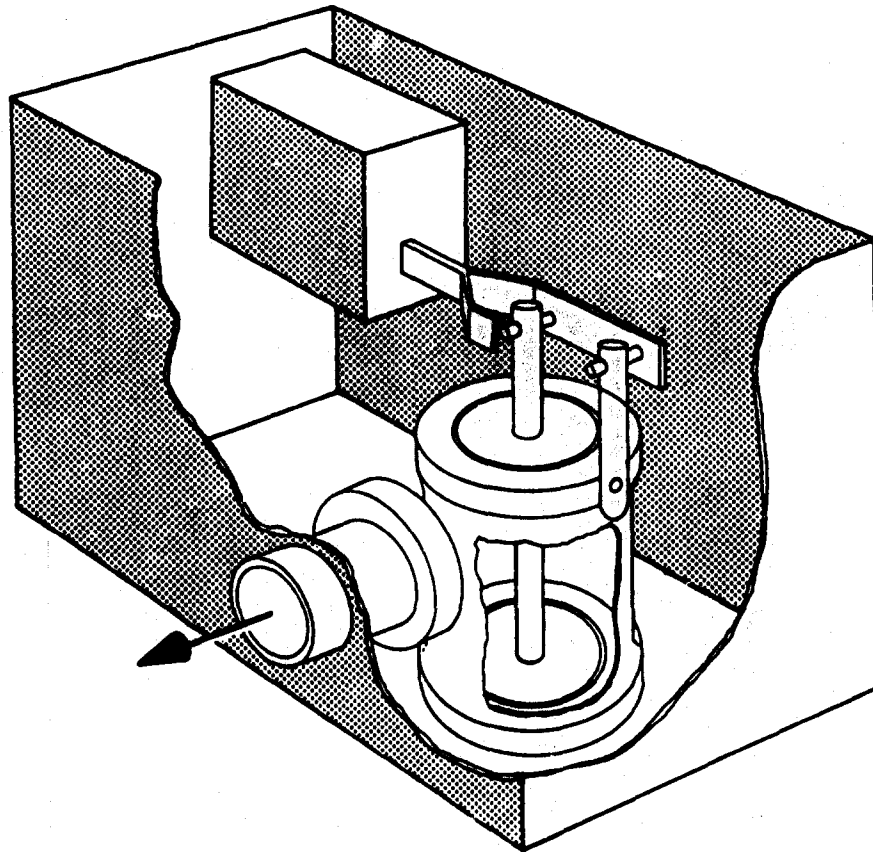

Figure 2. Cutaway view of float mechanism and valve controlling interstage brine transfer.

## OPERATION AND TESTING

The evaporator was run under various conditions to test the automatic control system and performance capabilities. Instrumentation included a feed water flow meter, water purity analyzer for the product, thermometers, and stage pressure measurement; the flow meter and thermometers may be seen in Figure 4. The pressure measurements were taken in each vapor space; a typical range of pressures is shown in Figure 8 for the eight stages.

A number of minor problems occurred initially, but these were easily remedied, and the unit has been operated successfully for several hundred hours. Freshwater output of 2,500-6,000 gpd was obtained with a heat input of 250,000 to 600,000 Btu/hr. This quantity of heat would be obtainable from generators of 60- to 150-kw capacity. The use of aluminum has resulted in limiting corrosion to an insignificant level. A certain amount of scaling of the condenser tubes has occurred, but this has not yet affected the operation of the unit.

The evaporator has proved to be capable of operating with a minimum of manual control and should be ideally suited for military requirements.

The computer program was designed to determine the suitability of the control mechanism in the experimental steel evaporator, and experimental and computed data agreed well. To generate theoretical data for the aluminum unit, it would be necessary to modify this computer program for the new physical and operating conditions. However, the experimental data collected for the aluminum unit show good agreement with the trends predicted by the computer program.

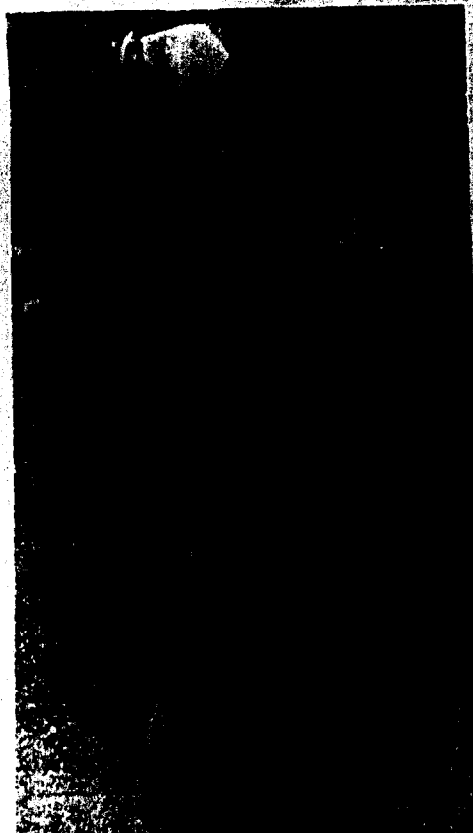

Figure 3. Disassembled float mechanism and valve controlling interstage distillate transfer.

**Best Available Copy**

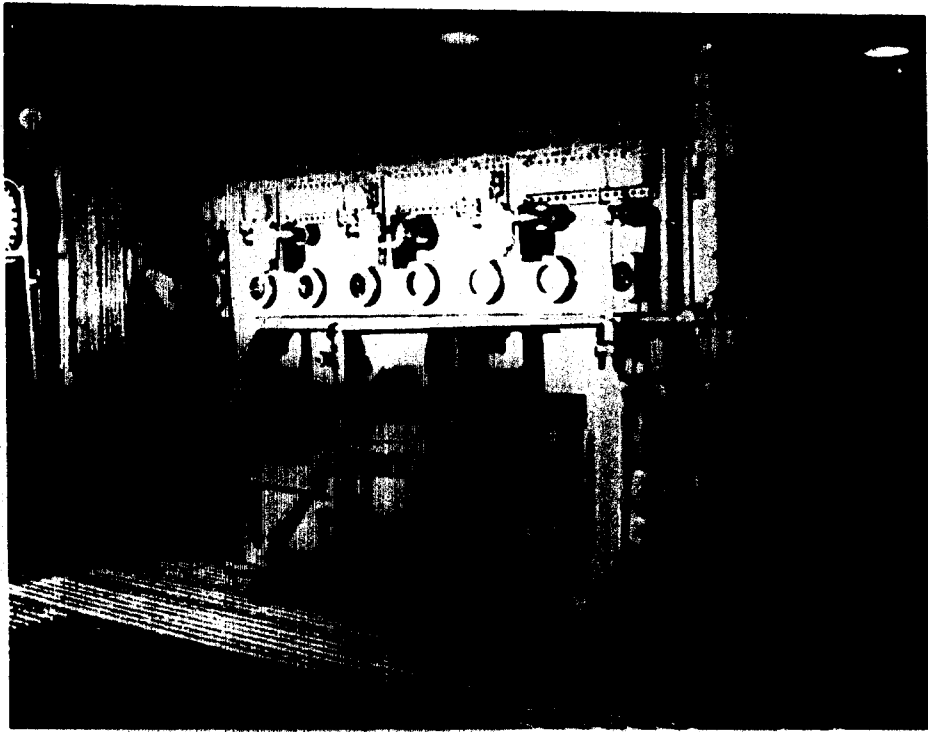

Figure 4. Overall view of aluminum flash evaporator unit.

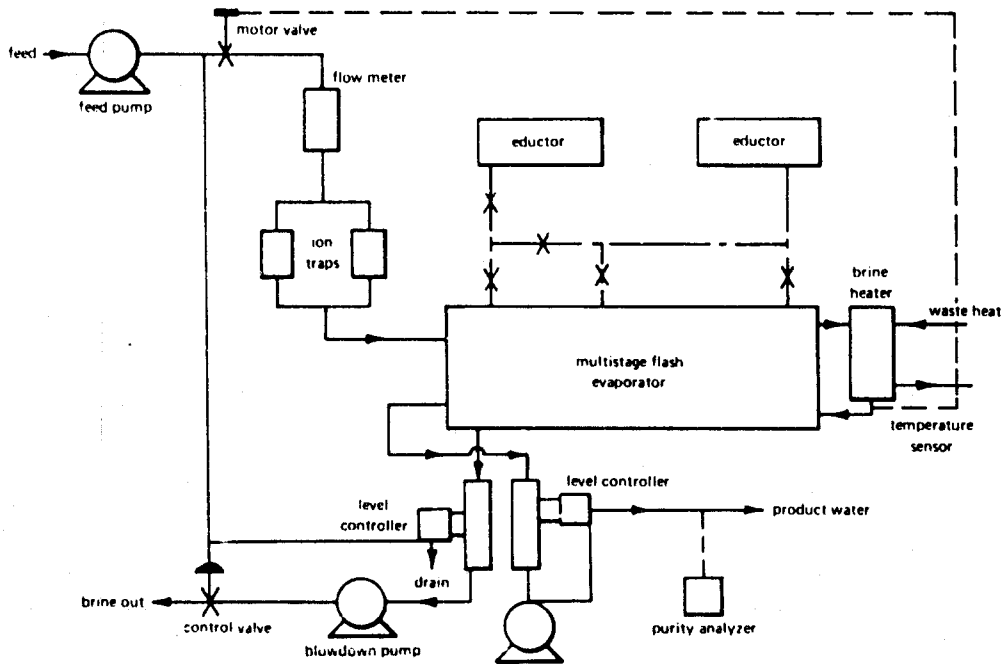

Figure 5. Flow diagram for flash evaporator.

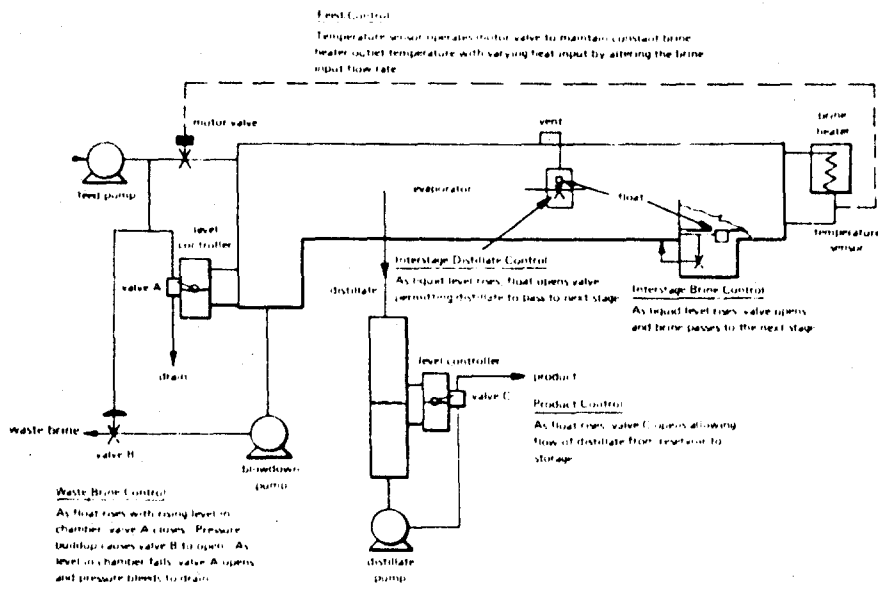

Figure 6. Diagram of control systems for flash evaporator.



Figure 7. End view of double set of condenser tubes.



Figure 8. Stage pressure measurement gage.

The Appendix contains detailed information on the performance of the aluminum desalination unit. Data are given on the heat transfer coefficients; on the effect of heat input on the feed rate, product rate, and coefficient of performance; and on the pressure and temperature variations within the operating unit.

## FINDINGS

1. The evaporator will produce between 2,500 and 6,000 gpd of freshwater on 250,000 to 600,000 Btu/hr of waste heat supplied from diesel generators having power outputs ranging between 60 and 150 kw.
2. The control systems for automatically adjusting interstage brine transfer and interstage distillate transfer permits the unit to operate from a variable heat source without manual control.
3. Aluminum construction has produced a unit which is lighter and more resistant to corrosion than comparable steel units.

## RECOMMENDATION

A new 16-stage prototype unit should be built and tested in the field to determine any problems which may arise under actual operating conditions by Seabees.

## Appendix

### EXPERIMENTAL DATA FOR MULTISTAGE FLASH EVAPORATOR

#### Range of Experimental Variables

Heat input	230,000-660,000 Btu/hr
Feed temperature	75-90°F
Heater outlet temperature	135-210°F

#### Dependent Variables

Feed (brine) flow rate	13-40 gpm
Stage pressures:	
First stage	9.5-25 in. vacuum
Eighth stage	28.3 in. vacuum minimum
Product rate	0.9-4.0 gpm
Overall average heat transfer coefficient	100-550 Btu/(hr)(ft <sup>2</sup> )(°F)
Coefficient of performance	2.5-3.5 lb/1,000 Btu

### HEAT TRANSFER COEFFICIENT

From the experimental data recorded during the operation of the still, it is possible to calculate an overall heat transfer coefficient for the unit. Figure 9 shows the variation of the average overall heat transfer coefficient with feed rate for two values of the controlled variables. The "average" heat transfer coefficient refers to the average value over the eight stages for each case.

The heat transfer coefficient is shown to increase for increasing flow rate and increasing heater outlet temperature. The effect of increasing the flow rate is to increase the tube-side heat transfer coefficient, which is strongly dependent on the velocity of the water in the tubes. The shell-side heat transfer coefficient, that is, condensing coefficient, is dependent on the temperature; an increase in heater outlet temperature results in an increase in the overall heat transfer coefficient.

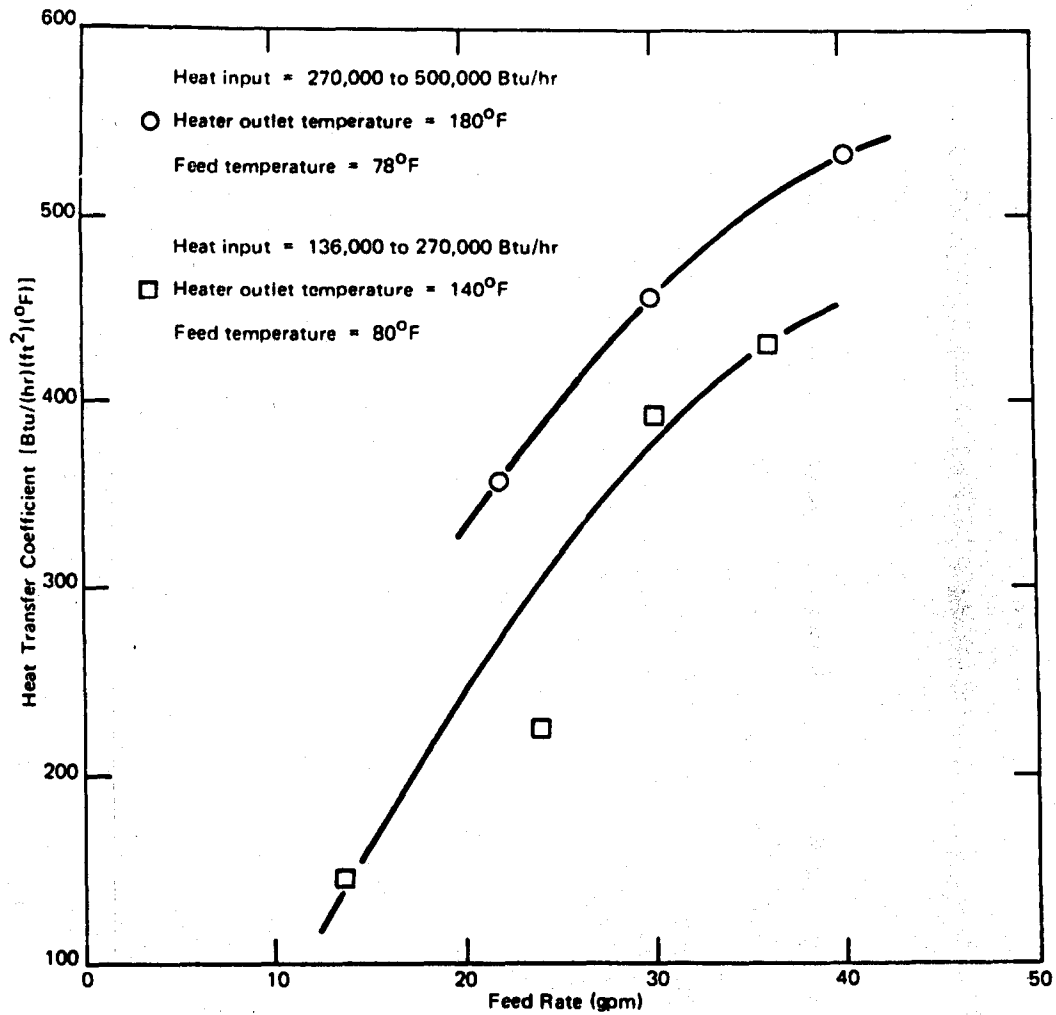

Figure 9. Variation of average experimental overall heat transfer coefficient with feed flow rate.

#### EFFECT OF HEAT INPUT RATE ON THE FEED RATE

The heat input to the system varies as the diesel generator load varies. This is the most important variable of the system, and the flow rate is controlled by the temperature-regulated valve to maintain a constant heater outlet temperature. Figure 10 illustrates the effect of heat load on the feed rate for two values of heater outlet temperature and approximately the same feed temperature. It is clear that as the feed and heater outlet temperatures approach each other, the slope of the curve increases considerably, and the feed rate becomes more sensitive to the variation in heat

input. A small change in the heat load at a low heater outlet temperature must be compensated for by a larger increase in feed rate to maintain a constant heater outlet temperature.

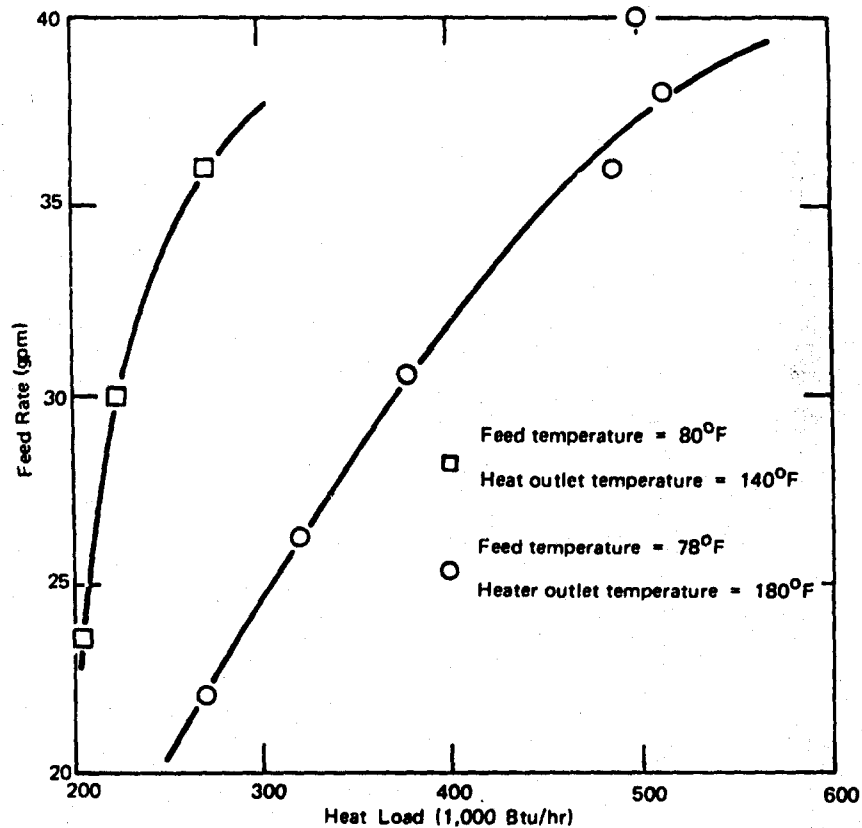

Figure 10. Experimental variation of feed rate with heat load.

#### EFFECT OF HEAT INPUT ON PRODUCT RATE AND COEFFICIENT OF PERFORMANCE

The freshwater produced by the unit for various heat loads is shown in Figure 11 for two heater outlet temperatures. It may be seen that the product rate is dependent to a great extent on the heat input. The two curves on the graph are almost coincident and of the same slope. This shows that the coefficient of performance, defined as the pounds of freshwater produced for every 1,000-Btu heat input, is relatively constant regardless of the heater outlet temperature. This is verified by calculation and it was found that the coefficient of performance decreased from a value of 3.0 to 2.65 when the heater outlet temperature was decreased from 180°F to 140°F. The fact

that the coefficient of performance decreases only 15% with the above alteration in the heater outlet temperature illustrates that the multistage flash evaporator is an efficient device for utilizing low temperature waste heat. No conclusive trend in the effect of heat load on the coefficient of performance could be found. Experimental errors were sufficient to mask any effect that may have occurred, and it is concluded that the coefficient of performance is not a strong function of heat load. It may be noted from Figures 10 and 11 that for the lower heater outlet temperature a small increase in the heat load results in a large increase in the feed rate but only a very small increase in the product rate. A much greater percentage of the feed passes through the blowdown.

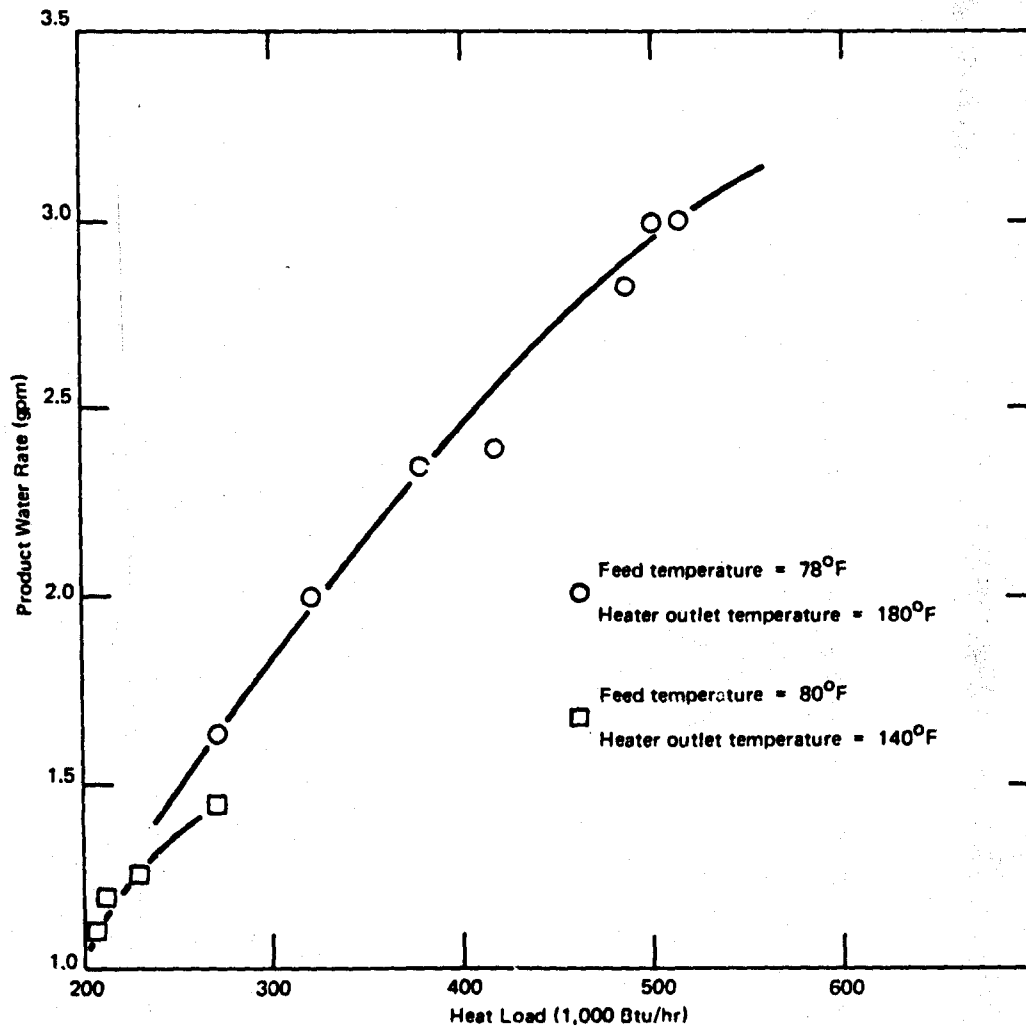

Figure 11. Experimental variation of product water flow rate with heat load.

## INTERSTAGE PRESSURE DROP

The interstage pressure drop is illustrated for several conditions in Figures 12 and 13. For constant feed and heater outlet temperatures, the interstage pressure drop varies little over a wide range of heat input (Figure 12). As the difference between the feed and heater outlet temperature decreases, the interstage pressure drop decreases and becomes very small for the last two or three stages in the unit (Figure 13).

A typical temperature profile for the unit is shown in Figure 14 to illustrate the temperature differences involved in each stage of the evaporator under operating conditions.

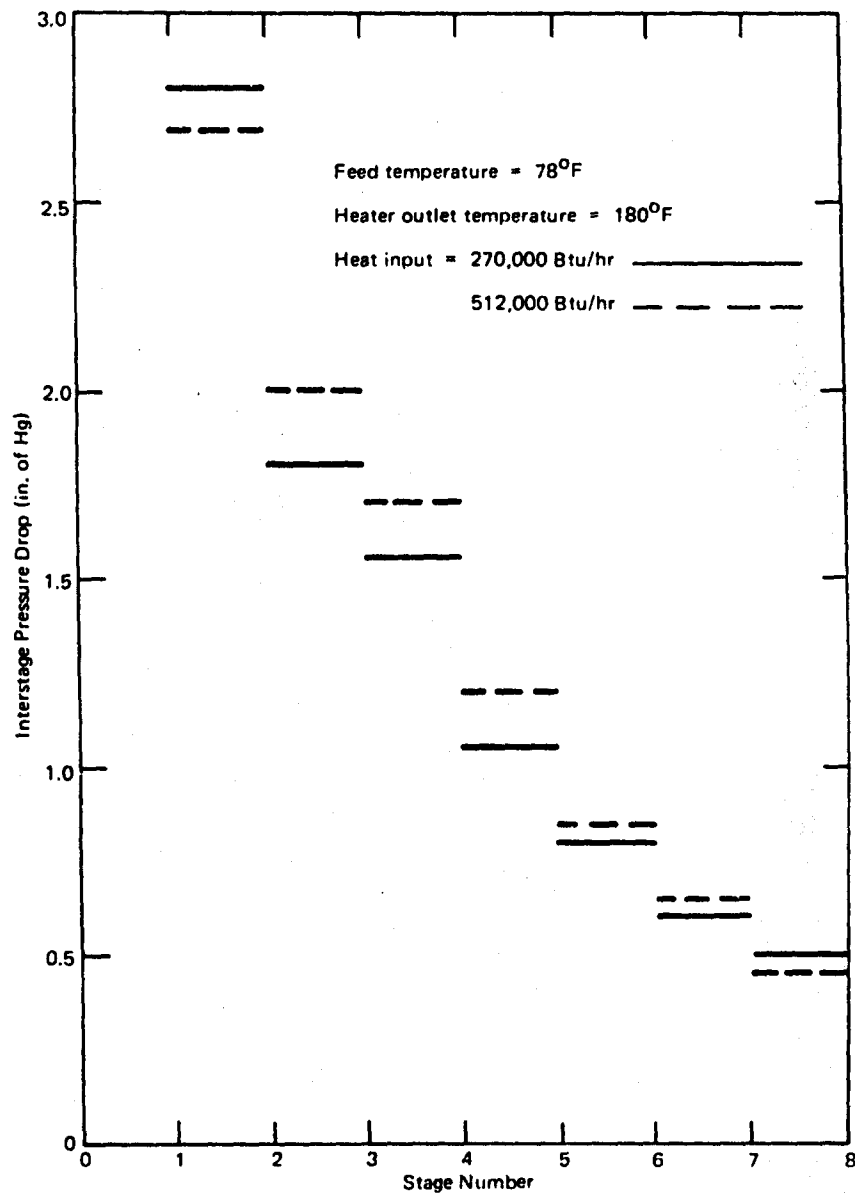

Figure 12. Experimental interstage pressure drop for 78°F feed water and 180°F heater outlet.

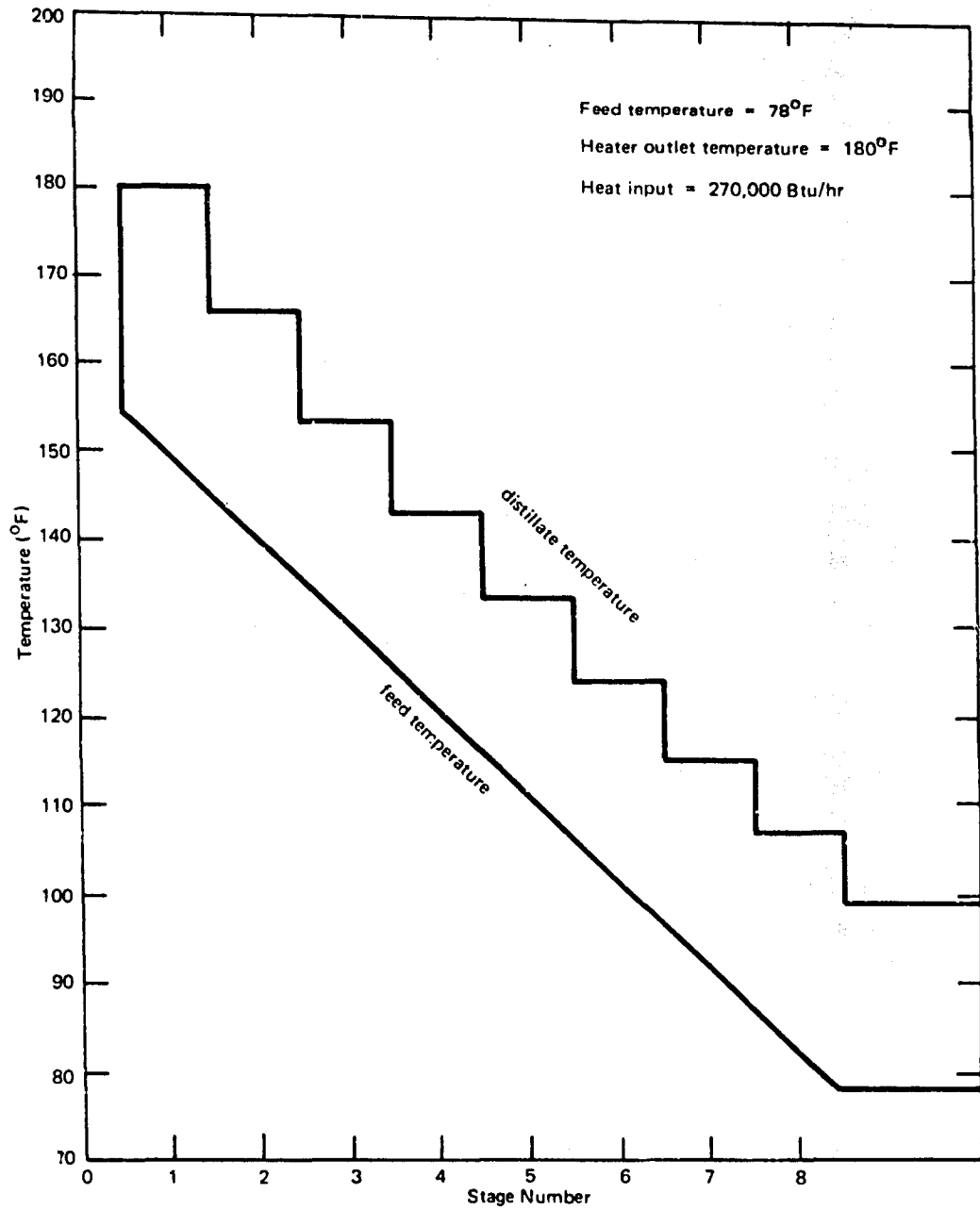

Figure 14. Temperature profile.

## REFERENCES

1. Naval Civil Engineering Laboratory. Technical Report R-587: Desalination processes for military application, by J. S. Williams and Allan S. Hodgson. Port Hueneme, Calif., June 1968.
2. \_\_\_\_\_ . Technical Report R-245: Distilling sea water with diesel generator waste heat, by J. S. Williams and W. R. Nehlsen. Port Hueneme, Calif., May 1963. (AD 406634)
3. \_\_\_\_\_ . Technical Report R-407: Waste-heat sea water conversion at Marcus Island, by J. S. Williams. Port Hueneme, Calif., Sept 1965. (AD 622557)
4. \_\_\_\_\_ . Technical Note N-792: Design optimization for a small multistage flash evaporator, by D. E. Williams. Port Hueneme, Calif., Feb 1966.
5. Jacobs Engineering Company. Report on Contract NBy-62169: Study of an automatic control system for a multi-stage flash evaporator with varying heat input rate for desalination of water, by J. Houseman, J. R. Canter and J. Doshi. Pasadena, Calif., June 1965. (AD 469084)

Unclassified

Security Classification

DOCUMENT CONTROL DATA - R & D

(Security classification of title, body of abstract and indexing annotation must be entered when the overall report is classified)

1. ORIGINATING ACTIVITY (Corporate author) <b>Naval Civil Engineering Laboratory Port Hueneme, Calif. 93041</b>		2a. REPORT SECURITY CLASSIFICATION <b>Unclassified</b>	
		2b. GROUP	
3. REPORT TITLE <b>MULTISTAGE FLASH DESALINATION UNIT UTILIZING DIESEL GENERATOR WASTE HEAT</b>			
4. DESCRIPTIVE NOTES (Type of report and inclusive dates) <b>Final; July 1965—June 1967</b>			
5. AUTHOR(S) (First name, middle initial, last name) <b>J. S. Williams and A. S. Hodgson</b>			
6. REPORT DATE <b>September 1968</b>		7a. TOTAL NO. OF PAGES <b>20</b>	7b. NO. OF REFS <b>5</b>
8a. CONTRACT OR GRANT NO.		9a. ORIGINATOR'S REPORT NUMBER(S) <b>TR-595</b>	
b. PROJECT NO. <b>Y-F015-11-04-611</b>		9b. OTHER REPORT NO(S) (Any other numbers that may be assigned this report)	
c.			
d.			
10. DISTRIBUTION STATEMENT <b>Each transmittal of this document outside the agencies of the U.S. Government must have prior approval of the Naval Civil Engineering Laboratory.</b>			
11. SUPPLEMENTARY NOTES		12. SPONSORING MILITARY ACTIVITY <b>Naval Facilities Engineering Command Washington, D. C.</b>	
13. ABSTRACT <p>A multistage flash evaporator utilizing diesel generator waste heat has been developed for desalination. After preliminary experimental studies, a unit was constructed to operate continuously from a variable heat supply and produce between 2,500 and 6,000 gpd of freshwater. Interstage brine transfer is automatically regulated by level controllers in each stage, thus eliminating the need for manual control of the unit as the generator load and hence heat output varies. All-aluminum construction has reduced corrosion, and the unit has performed satisfactorily during tests. Typical experimental data is included.</p>			

DD FORM 1473 (PAGE 1)

1 NOV 65  
S/N 0101-807-6801

Unclassified

Security Classification

KEY WORDS	LINK A		LINK B		LINK C	
	ROLE	WT	ROLE	WT	ROLE	WT
Desalination						
Seawater						
Distillation						
Multistage evaporator						
Waste heat						
Variable heat source						
Brine flow control						
Vapor compression distillation						