

UNCLASSIFIED

AD NUMBER

AD842232

LIMITATION CHANGES

TO:

Approved for public release; distribution is unlimited.

FROM:

Distribution authorized to DoD only; Administrative/Operational Use; OCT 1968. Other requests shall be referred to NASA Marshall Space Flight Center, Huntsville, AL.

AUTHORITY

USAEDC ltr, 12 Jul 1974

THIS PAGE IS UNCLASSIFIED

Cy 1

**ALTITUDE DEVELOPMENTAL TESTING OF THE
J-2 ROCKET ENGINE IN PROPULSION ENGINE
TEST CELL (J-4) (TESTS J4-1801-37 AND 38)**



C. E. Pillow

ARO, Inc.

PROPERTY OF U. S. AIR FORCE
AEDC LIBRARY
F40600-69-C-0001

October 1968

~~This document has been approved for public release
its distribution is unlimited.~~

Each transmittal of this document outside the Department of Defense must have prior approval of NASA, Marshall Space Flight Center (I-E-J), Huntsville, Ala.

This document has been approved for public release
its distribution is unlimited.

LARGE ROCKET FACILITY

Per AF letter dt'd. 2 July 74 signed William O. Cole

**ARNOLD ENGINEERING DEVELOPMENT CENTER
AIR FORCE SYSTEMS COMMAND
ARNOLD AIR FORCE STATION, TENNESSEE**

PROPERTY OF U. S. AIR FORCE
AEDC LIBRARY
F40600-69-C-0001

AEDC TECHNICAL LIBRARY



TE68 TED000 0220 5 0720 00031 8323

NOTICES

When U. S. Government drawings specifications, or other data are used for any purpose other than a definitely related Government procurement operation, the Government thereby incurs no responsibility nor any obligation whatsoever, and the fact that the Government may have formulated, furnished, or in any way supplied the said drawings, specifications, or other data, is not to be regarded by implication or otherwise, or in any manner licensing the holder or any other person or corporation, or conveying any rights or permission to manufacture, use, or sell any patented invention that may in any way be related thereto.

Qualified users may obtain copies of this report from the Defense Documentation Center.

References to named commercial products in this report are not to be considered in any sense as an endorsement of the product by the United States Air Force or the Government.

ALTITUDE DEVELOPMENTAL TESTING OF THE
J-2 ROCKET ENGINE IN PROPULSION ENGINE
TEST CELL (J-4) (TESTS J4-1801-37 AND 38)

C. E. Pillow
ARO, Inc.

Each transmittal of this document outside the Department of Defense must have prior approval of NASA, Marshall Space Flight Center (I-E-J), Huntsville, Ala.

This document has been approved for public release
its distribution is unlimited. *Per AF of the
12 July 74
Signed William O. Cole*

FOREWORD

The work reported herein was sponsored by the National Aeronautics and Space Administration (NASA), Marshall Space Flight Center (MSFC) (I-E-J), under System 921E, Project 9194.

The results of the tests presented were obtained by ARO, Inc. (a subsidiary of Sverdrup & Parcel and Associates, Inc.), contract operator of the Arnold Engineering Development Center (AEDC), Air Force Systems Command (AFSC), Arnold Air Force Station, Tennessee, under Contract F40600-69-C-0001. Program direction was provided by NASA/MSFC; engineering liaison was provided by North American Rockwell Corp., Rocketdyne Division, manufacturer of the J-2 rocket engine and McDonnell Douglas Corp., Douglas Aircraft Company, Missile and Space Systems Division, manufacturer of the S-IVB stage. The testing reported herein was conducted April 16 and 23, 1968, in Propulsion Engine Test Cell (J-4) of the Large Rocket Facility (LRF) under ARO Project No. KA1801. The manuscript was submitted for publication on August 16, 1968.

Information in this report is embargoed under the Department of State International Traffic in Arms Regulations. This report may be released to foreign governments by departments or agencies of the U. S. Government subject to approval of NASA, Marshall Space Flight Center (I-E-J), or higher authority. Private individuals or firms require a Department of State export license.

This technical report has been reviewed and is approved.

Edgar D. Smith
Major, USAF
AF Representative, LRF
Directorate of Test

Roy R. Croy, Jr.
Colonel, USAF
Director of Test

ABSTRACT

Eight firings and two partial transition tests of the J-2 rocket engine were accomplished during test periods J4-1801-37 and 38. These tests periods were conducted on April 16 and 23, 1968, respectively. Each of these firings was in support of the S-V/S-IVB stage engine to investigate engine start transients for first burn and restart simulations. The partial transition tests were to evaluate thrust chamber temperature effects on the engine start transients. All objectives were successfully met with a total accumulated firing duration of 156.6 sec.

This document is subject to special export controls and each transmittal to foreign governments or foreign nationals may be made only with prior approval of NASA, Marshall Space Flight Center (I-E-J), Huntsville, Alabama.

This document has been approved for public release
and its distribution is unlimited.

*Per AF Letter
dated 12 July 74
Signed William O.
Cole.*

CONTENTS

	<u>Page</u>
ABSTRACT	iii
NOMENCLATURE	ix
I. INTRODUCTION	1
II. APPARATUS	1
III. PROCEDURE	7
IV. RESULTS AND DISCUSSION	8
V. SUMMARY OF RESULTS.	17
REFERENCES.	18

APPENDIXES

I. ILLUSTRATIONS

Figure

1. Test Cell J-4 Complex	21
2. Test Cell J-4, Artist's Conception.	22
3. Engine Details	23
4. S-IVB Battleship Stage/J-2 Engine Schematic	24
5. Engine Schematic	25
6. Engine Start Logic Schematic	26
7. Engine Start and Shutdown Sequence	27
8. Engine Start Conditions for the Pump Inlets, Start Tank, and Helium Tank	29
9. Thermal Conditioning History of Engine Components, Firing 37A	31
10. Engine Transient Operation, Firing 37A	32
11. Fuel Pump Start Transient Performance, Firing 37A	36
12. Engine Ambient and Combustion Chamber Pressures, Firing 37A.	37
13. Thermal Conditioning History of Engine Components, Firing 37B	38

<u>Figure</u>	<u>Page</u>
14. Engine Transient Operation, Firing 37B	39
15. Fuel Pump Start Transient Performance, Firing 37B	43
16. Engine Ambient and Combustion Chamber Pressures, Firing 37B.	44
17. Thermal Conditioning History of Engine Components, Firing 37C	45
18. Engine Transient Operation, Firing 37C	46
19. Fuel Pump Start Transient Performance, Firing 37C	50
20. Engine Ambient and Combustion Chamber Pressures, Firing 37C.	51
21. Thermal Conditioning History of Engine Components, Firing 37D	52
22. Engine Transient Operation, Firing 37D	53
23. Fuel Pump Start Transient Performance, Firing 37D	57
24. Engine Ambient and Combustion Chamber Pressures, Firing 37D.	58
25. Thermal Conditioning History of Engine Components, Firing 37E	59
26. Engine Transient Operation, Firing 37E	60
27. Fuel Pump Start Transient Performance, Firing 37E	62
28. Engine Ambient and Combustion Chamber Pressures, Firing 37E.	63
29. Thermal Conditioning History of Engine Components, Firing 38A	64
30. Engine Transient Operation, Firing 38A	65
31. Fuel Pump Start Transient Performance, Firing 38A	69
32. Engine Ambient and Combustion Chamber Pressures, Firing 38A	70

<u>Figure</u>	<u>Page</u>
33. Thermal Conditioning History of Engine Components, Firing 38B	71
34. Engine Transient Operation, Firing 38B	72
35. Fuel Pump Start Transient Performance, Firing 38B	74
36. Engine Ambient and Combustion Chamber Pressures, Firing 38B.	75
37. Thermal Conditioning History of Engine Components, Firing 38C	76
38. Engine Transient Operation, Firing 38C	77
39. Fuel Pump Start Transient Performance, Firing 38C	81
40. Engine Ambient and Combustion Chamber Pressures, Firing 38C.	82
41. Thermal Conditioning History of Engine Components, Firing 38D	83
42. Engine Transient Operation, Firing 38D	84
43. Fuel Pump Start Transient Performance, Firing 38D	88
44. Engine Ambient and Combustion Chamber Pressures, Firing 38D.	89
45. Thermal Conditioning History of Engine Components, Firing 38E	90
46. Engine Transient Operation, Firing 38E	91
47. Fuel Pump Start Transient Performance, Firing 38E	93
48. Engine Ambient and Combustion Chamber Pressures, Firing 38E.	94
49. Thrust Chamber Temperature Conditioning Effects on Fuel Pump Flow Coefficient, Firings 36E, 37E, and 38E	95
50. Thrust Chamber Temperature Conditioning Effects on Fuel Pump Head Rise Coefficient, Firings 36E, 37E, and 38E	96

<u>Figure</u>	<u>Page</u>
51. Thrust Chamber Temperature Conditioning Effects on Fuel Pump Start Transient Performance, Firings 36E, 37E, and 38E	97
52. Thrust Chamber Temperature Conditioning Effects on Gas Generator Fuel Injector Pressure, Firings 36E, 37E, and 38E	98
53. Thrust Chamber Temperature Conditioning Effects on Gas Generator Outlet Temperature Transient, Firings 36E, 37E, and 38E.	99
54. Thrust Chamber Temperature Conditioning Effects on Fuel Pump Flow Coefficient, Firings 37D and 38D	100
55. Thrust Chamber Temperature Conditioning Effects of Fuel Pump Head Rise Coefficient, Firings 37D and 38D	101
56. Thrust Chamber Temperature Conditioning Effects on Fuel Pump Start Transient Performance, Firings 37D and 38D	102
57. Thrust Chamber Temperature Conditioning Effects on Gas Generator Chamber Pressure Transients, Firings 37D and 38D	103
58. Thrust Chamber Temperature Conditioning Effects on Gas Generator Outlet Temperature Transient, Firings 37D and 38D	104
59. Fuel Pump Inlet Pressure Effect on Fuel Pump Head Rise Coefficient, Firings 36D and 37D	105
60. Fuel Pump Inlet Pressure Effect on Fuel Pump Flow Coefficient, Firings 36D and 37D.	106
61. Fuel Pump Inlet Pressure Effect on Fuel Pump Start Transient Performance, Firings 36D and 37D	107
62. Fuel Pump Inlet Pressure Effect on Gas Generator Fuel Injector Pressure, Firings 36D and 37D	108
63. Fuel Pump Inlet Pressure Effect on Gas Generator Chamber Pressure Transients, Firings 36D and 37D	109

<u>Figure</u>	<u>Page</u>
64. Fuel Pump Inlet Pressure Effect on Gas Generator Outlet Temperature Transients, Firings 36D and 37D	110
 II. TABLES	
I. Major Engine Components.	111
II. Summary of Engine Orifices.	112
III. Engine Modifications (between Tests J4-1801-36 and J4-1801-38)	113
IV. Engine Components Replacements (between Tests J4-1801-36 and J4-1801-38)	114
V. Engine Purge and Component Conditioning Sequence	115
VI. Summary of Test Requirements and Results	116
VII. Engine Valve Timings	118
VIII. Engine Performance Summary	120
III. INSTRUMENTATION.	121
IV. METHOD OF CALCULATION (PERFORMANCE PROGRAM)	133

NOMENCLATURE

A	Area, in. ²
ASI	Augmented spark igniter
ES	Engine start, designated as the time that helium control and ignition phase solenoids are energized
GG	Gas generator
MOV	Main oxidizer valve
NPSH	Net positive suction head, ft
STDV	Start tank discharge valve
t_0	Defined as the time at which the opening signal is applied to the start tank discharge valve solenoid

VSC Vibration safety counts, defined as the time at which engine vibration was in excess of 150 g rms in a 960- to 6000-Hz frequency range

SUBSCRIPTS

f Force
m Mass
t Throat

SECTION I INTRODUCTION

Testing of the Rocketdyne J-2 rocket engine using an S-IVB battleship stage has been in progress since July, 1966, at AEDC in support of the J-2 engine application on the Saturn IB and Saturn V launch vehicles for the NASA Apollo Program. The eight firings and two partial transition tests reported herein were conducted during test periods J4-1801-37 and 38 on April 16 and 23, 1968, respectively, in Propulsion Engine Test Cell (J-4) (Figs. 1 and 2, Appendix I) of the Large Rocket Facility (LRF). These tests were conducted at pressure altitudes ranging from 75,000 to 110,000 ft (geometric pressure altitude, Z, Ref. 1) at engine start to investigate engine first burn and restart transients. Selected engine components were conditioned to predicted flight conditions.

Data collected to accomplish the test objectives are presented herein. The results of the previous test period are presented in Ref. 2.

SECTION II APPARATUS

2.1 TEST ARTICLE

The test article was a J-2 rocket engine (Fig. 3) designed and developed by Rocketdyne Division of North American Rockwell Corporation. The engine uses liquid oxygen and liquid hydrogen as propellants and has a thrust rating of 230,000 lb_f at an oxidizer-to-fuel mixture ratio of 5.5. An S-IVB battleship stage, with flight-type S-IVB stage propellant supply ducts, was used to supply propellants to the engine. A schematic of the battleship stage is presented in Fig. 4.

Listings of major engine components and engine orifices for this test period are presented in Tables I and II, respectively (Appendix II). All engine modifications and component replacements performed since the previous test period are presented in Tables III and IV, respectively.

2.1.1 J-2 Rocket Engine

The J-2 rocket engine (Figs. 3 and 5, Ref. 3) features the following major components:

1. Thrust Chamber - The tubular-walled, bell-shaped thrust chamber consists of an 18.6-in. -diam combustion chamber (8.0 in. long from the injector mounting to the throat inlet) with a characteristic length (L^*) of 24.6 in., a 170.4-in.² throat area, and a divergent nozzle with an expansion ratio of 27.1. Thrust chamber length (from the injector flange to the nozzle exit) is 107 in. Cooling is accomplished by the circulation of engine fuel flow downward from the fuel manifold through 180 tubes and then upward through 360 tubes to the injector.
2. Thrust Chamber Injector - The injector is a concentric-orificed (concentric fuel orifices around the oxidizer post orifices), porous-faced injector. Fuel and oxidizer injector orifice areas are 25.0 and 16.0 in.², respectively. The porous material, forming the injector face, allows approximately 3.5 percent of total fuel flow to transpiration cool the face of the injector.
3. Augmented Spark Igniter - The augmented spark igniter unit is mounted on the thrust chamber injector and supplies the initial energy source to ignite propellants in the main combustion chamber. The augmented spark igniter chamber is an integral part of the thrust chamber injector. Fuel and oxidizer are ignited in the combustion area by two spark plugs.
4. Fuel Turbopump - The turbopump is composed of a two-stage turbine-stator assembly, an inducer, and a seven-stage axial-flow pump. The pump is self lubricated and nominally produces, at rated conditions, a head rise of 38,215 ft (1248 psia) of liquid hydrogen at a flow rate of 8585 gpm for a rotor speed of 27,265 rpm.
5. Oxidizer Turbopump - The turbopump is composed of a two-stage turbine-stator assembly and a single-stage centrifugal pump. The pump is self lubricated and nominally produces, at rated conditions, a head rise of 2170 ft (1107 psia) of liquid oxygen at a flow rate of 2965 gpm for a rotor speed of 8688 rpm.
6. Gas Generator - The gas generator consists of a combustion chamber containing two spark plugs, a pneumatically operated control valve containing oxidizer and fuel poppets, and an injector assembly. The oxidizer and fuel poppets provide a fuel lead to the gas generator combustion chamber. The high energy gases produced by the gas generator are directed to the fuel

turbine and then to the oxidizer turbine (through the turbine crossover duct) before being exhausted into the thrust chamber at an area ratio (A/A_t) of approximately 11.

7. Propellant Utilization Valve - The motor-driven propellant utilization valve is mounted on the oxidizer turbopump and bypasses liquid oxygen from the discharge to the inlet side of the pump to vary engine mixture ratio.
8. Propellant Bleed Valves - The pneumatically operated fuel and oxidizer bleed valves provide pressure relief for the boiloff of propellants trapped between the battleship stage prevalves and main propellant valves at engine shutdown.
9. Integral Hydrogen Start Tank and Helium Tank - The integral tanks consist of a 7258-in.³ sphere for hydrogen with a 1000-in.³ sphere for helium located within it. Pressurized gaseous hydrogen in the start tank provides the initial energy source for spinning the propellant turbopumps during engine start. The helium tank provides a helium pressure supply to the engine pneumatic control system.
10. Oxidizer Turbine Bypass Valve - The pneumatically actuated oxidizer turbine bypass valve provides control of the fuel turbine exhaust gases directed to the oxidizer turbine in order to control the oxidizer-to-fuel turbine spinup relationship. The fuel turbine exhaust gases which bypass the oxidizer turbine are discharged into the thrust chamber.
11. Main Oxidizer Valve - The main oxidizer valve is a pneumatically actuated, two-stage, butterfly-type valve located in the oxidizer high pressure duct between the turbopump and the main injector. The first-stage actuator positions the main oxidizer valve at the 14-deg position to obtain initial thrust chamber ignition; the second-stage actuator ramps the main oxidizer valve full open to accelerate the engine to main-stage operation.
12. Main Fuel Valve - The main fuel valve is a pneumatically actuated butterfly-type valve located in the fuel high pressure duct between the turbopump and the fuel manifold.
13. Pneumatic Control Package - The pneumatic control package controls all pneumatically operated engine valves and purges.
14. Electrical Control Assembly - The electrical control assembly provides the electrical logic required for proper sequencing of engine components during operation.

15. Primary and Auxiliary Flight Instrumentation Packages - The instrumentation packages contain sensors required to monitor critical engine parameters. The packages provide environmental control for the sensors.

2.1.2 S-IVB Battleship Stage

The S-IVB battleship stage is approximately 22 ft in diameter and 49 ft long and has a maximum propellant capacity of 46,000 lb of liquid hydrogen and 199,000 lb of liquid oxygen. The propellant tanks, fuel above oxidizer, are separated by a common bulkhead. Propellant pre-valves, in the low pressure ducts (external to the tanks) interfacing the stage and the engine, retain propellant in the stage until being admitted into the engine to the main propellant valves and serve as emergency engine shutoff valves. Propellant recirculation pumps in both fuel and oxidizer tanks are utilized to circulate propellants through the low pressure ducts and turbopumps before engine start to stabilize hardware temperatures near normal operating levels and to prevent propellant temperature stratification. Vent and relief valve systems are provided for both propellant tanks.

Pressurization of the fuel and oxidizer tanks was accomplished by facility systems using hydrogen and helium, respectively, as the pressurizing gases. The engine-supplied gaseous hydrogen for fuel tank pressurization during S-IVB flight was routed to the facility vent system.

2.2 TEST CELL

Test cell J-4, Fig. 2, is a vertically oriented test unit designed for static testing of liquid-propellant rocket engines and propulsion systems at pressure altitudes of 100,000 ft. The basic cell construction provides a 1.5-million-lbf-thrust capacity. The cell consists of four major components (1) test capsule, 48 ft in diameter and 82 ft in height, situated at grade level and containing the test article; (2) spray chamber, 100 ft in diameter and 250 ft in depth, located directly beneath the test capsule to provide exhaust gas cooling and dehumidification; (3) coolant water, steam, nitrogen (gaseous and liquid), hydrogen (gaseous and liquid), and liquid oxygen and gaseous helium storage and delivery systems for operation of the cell and test article; and (4) control building, containing test article controls, test cell controls, and data acquisition equipment. Exhaust machinery is connected with the spray chamber and maintains a minimum test cell pressure before and after the engine firing and exhausts the products of combustion from the engine firing. Before

a firing, the facility steam ejector, in series with the exhaust machinery, provides a pressure altitude of 100,000 ft in the test capsule. A detailed description of the test cell is presented in Ref. 4.

The battleship stage and the J-2 engine were oriented vertically downward on the centerline of the diffuser-steam ejector assembly. This assembly consisted of a diffuser duct (20 ft in diameter by 150 ft in length), a centerbody steam ejector within the diffuser duct, a diffuser insert (13.5 ft in diameter by 30 ft in length) at the inlet to the diffuser duct, and a gaseous nitrogen annular ejector above the diffuser insert. The diffuser insert was provided for dynamic pressure recovery of the engine exhaust gases and to maintain engine ambient pressure altitude (attained by the steam ejector) during the engine firing. The annular ejector was provided to suppress steam recirculation into the test capsule during steam ejector shutdown. The test cell was also equipped with (1) a gaseous nitrogen purge system for continuously inerting the normal air in-leakage of the cell; (2) a gaseous nitrogen repressurization system for raising test cell pressure, after engine cutoff, to a level equal to spray chamber pressure and for rapid emergency inerting of the capsule; and (3) a spray chamber liquid nitrogen supply and distribution manifold for initially inerting the spray chamber and exhaust ducting and for increasing the molecular weight of the hydrogen-rich exhaust products.

An engine component conditioning system was provided for temperature conditioning engine components. The conditioning system utilized a liquid hydrogen-helium heat exchanger to provide cold helium gas for component conditioning. Engine components requiring temperature conditioning were the thrust chamber, crossover duct, and main oxidizer valve second-stage actuator. Helium was routed internally through the crossover duct and tubular-walled thrust chamber and externally over the main oxidizer valve second-stage actuator.

2.3 INSTRUMENTATION

Instrumentation systems were provided to measure engine, stage, and facility parameters. The engine instrumentation was comprised of (1) flight instrumentation for the measurement of critical engine parameters and (2) facility instrumentation which was provided to verify the flight instrumentation and to measure additional engine parameters. The flight instrumentation was provided and calibrated by the engine manufacturer; facility instrumentation was initially calibrated and periodically recalibrated at AEDC. Appendix III contains a list of all measured test parameters and the locations of selected sensing points.

Pressure measurements were made using strain-gage-type pressure transducers. Temperature measurements were made using resistance temperature transducers and thermocouples. Oxidizer and fuel turbopump shaft speeds were sensed by magnetic pickup. Fuel and oxidizer flow rates to the engine were measured by turbine-type flowmeters which are an integral part of the engine. The propellant recirculation flow rates were also monitored with turbine-type flowmeters. Vibrations were measured by accelerometers mounted on the oxidizer injector dome and on the turbopumps. Primary engine and stage valves were instrumented with linear potentiometers and limit switches.

The data acquisition systems were calibrated by (1) precision electrical shunt resistance substitution for the pressure transducers and resistance temperature transducer units; (2) voltage substitution for the thermocouples; (3) frequency substitution for shaft speeds and flowmeters; and (4) frequency-voltage substitution for accelerometers.

The types of data acquisition and recording systems used during this test period were (1) a multiple-input digital data acquisition system (MicroSADIC®) scanning each parameter at 40 samples per second and recording on magnetic tape; (2) single-input, continuous-recording FM systems recording on magnetic tape; (3) photographically recording galvanometer oscillographs; (4) direct-inking, null-balance potentiometer-type X-Y plotters and strip charts; and (5) optical data recorders. Applicable systems were calibrated before each test (atmospheric and altitude calibrations). Television cameras, in conjunction with video tape recorders, were used to provide visual coverage during an engine firing, as well as for replay capability for immediate examination of unexpected events.

2.4 CONTROLS

Control of the J-2 engine, battleship stage, and test cell systems during the terminal countdown was provided from the test cell control room. A facility control logic network was provided to interconnect the engine control system, major stage systems, the engine safety cutoff system, the observer cutoff circuits, and the countdown sequencer. A schematic of the engine start control logic is presented in Fig. 6. The sequence of engine events for a normal start and shutdown is presented in Figs. 7a and b. Two control logics for sequencing the stage pre-valves and recirculation systems with engine start for simulating engine flight start sequences are presented in Figs. 7c and d.

SECTION III PROCEDURE

Preoperational procedures were begun several hours before the test period. All consumable storage systems were replenished, and engine inspections, leak checks, and drying procedures were conducted. Propellant tank pressurants and engine pneumatic and purge gas samples were taken to ensure that specification requirements were met. Chemical analysis of propellants was provided by the propellant suppliers. Facility sequence, engine sequence, and engine abort checks were conducted within a 24-hr time period before an engine firing to verify the proper sequence of events. Facility and engine sequence checks consisted of verifying the timing of valves and events to be within specified limits; the abort checks consisted of electrically simulating engine malfunctions to verify the occurrence of an automatic engine cutoff signal. A final engine sequence check was conducted immediately preceding the test period.

Oxidizer dome, gas generator oxidizer injector, and thrust chamber jacket purges were initiated before evacuating the test cell. After completion of instrumentation calibrations at atmospheric conditions, the test cell was evacuated to approximately 0.5 psia with the exhaust machinery, and instrumentation calibrations at altitude conditions were conducted. Immediately before loading propellants on board the vehicle, the cell and exhaust-ducting atmosphere was inerted. At this same time, the cell nitrogen purge was initiated for the duration of the test period, except for the engine firing. The vehicle propellant tanks were then loaded, and the remainder of the terminal countdown was conducted. Temperature conditioning of the various engine components was accomplished as required, using the facility-supplied engine component conditioning system. Engine components which required temperature conditioning were the thrust chamber, the crossover duct, and main oxidizer valve second-stage actuator. Table V presents the engine purges and thermal conditioning operations during the terminal countdown and immediately following the engine firing.

SECTION IV RESULTS AND DISCUSSION

4.1 TEST SUMMARY

Eight firings and two partial transition tests were accomplished during test periods J4-1801-37 and J4-1801-38 which were conducted on April 16 and 23, 1968, respectively. Each of these firings was in support of the S-V/S-IVB stage engine to investigate start transients for first burn, two orbit restarts, 80-min orbital coast restart, and 6-hr orbital coast restart simulation. The partial transition tests were to evaluate thrust chamber thermal conditioning on engine start transient. The accumulated firing duration for these test periods was 156.6 sec.

Each of the first burn firings was conducted with a propellant utilization valve excursion from the null to the closed position approximately 10 sec after start tank discharge, which resulted in a change in mixture ratio from approximately 5.0 to 5.5. The restart after the simulated 6-hr orbital coast included a propellant utilization valve excursion from the open to closed position at about 14 sec after start tank discharge. This resulted in a change in mixture ratio from approximately 4.5 to 5.5. Each of the 80-min restart simulations was conducted with the propellant utilization valve in the open position. The partial transition tests were conducted with the propellant utilization valve in the null position.

Firing 38B was prematurely terminated at $t_0 + 1.242$ sec as the result of a momentary loss of the oxidizer pre valve "open" limit switch feedback signal. However, the duration was sufficient enough that the test objectives were met.

The thrust chamber, crossover duct, and the main oxidizer valve second-stage actuator were thermally conditioned to targets predicted for S-IVB flight conditions. A summary of test requirements and results is presented in Table VI. Engine start conditions for the pump inlets, start tank, and helium tank are shown in Fig. 8. Component thermal conditioning histories and engine start and shutdown transients for tests J4-1801-37 and J4-1801-38 are shown in Figs. 9 through 48. Selected engine valve timings are tabulated in Table VII for the engine start and shutdown transients. Calculated engine performance (Appendix IV) for the four 32.5-sec duration firings is presented in Table VIII. Specific test objectives and a brief summary of results obtained from each firing are presented as follows:

Firing	Test Objective	Results
37A	S-IVB first burn simulation to evaluate engine start transients at minimum start energy	A successful 32.6-sec firing was achieved. Thrust chamber ignition (chamber pressure = 100 psia) was recorded at $t_0 + 1.047$ sec with main-stage operation (chamber pressure = 550 psia) recorded at $t_0 + 2.117$ sec. Excessive engine vibration (VSC) was recorded for 38 msec beginning at $t_0 + 1.045$ sec. The gas generator temperature peak was 1270°F. Minimum fuel pump stall margin was approximately 400 gpm at about 18,000 rpm.
37B	S-IVB 80-min restart simulation to evaluate engine start transients with narrow band start tank relief valve conditions of 1200 psia and -260°F and coldest (-200°F) expected thrust chamber conditions	A 7.6-sec firing was successfully accomplished. Thrust chamber ignition was recorded at $t_0 + 0.987$ sec with main-stage operation occurring at $t_0 + 2.050$ sec. The gas generator temperature peak was 1850°F. Engine vibration (VSC) was recorded for 15 msec beginning at $t_0 + 0.994$ sec.
37C	S-IVB restart simulation, with low starting energy and -100°F crossover duct after a simulated 6-hr orbital coast	A 32.6-sec firing was successfully achieved. Thrust chamber ignition was recorded at $t_0 + 1.090$ sec. Main-stage operation occurred at $t_0 + 2.800$ sec. Excessive engine vibration (VSC) was recorded for 55 msec beginning at $t_0 + 1.087$ sec. The initial gas generator outlet temperature peak was 890°F.
37D	S-IVB 80-min restart simulation to evaluate engine start transients with	A successful 7.6-sec firing was accomplished. Thrust chamber ignition was recorded at

Firing	Test Objectives	Results
37D (con't)	narrow band start tank relief valve conditions of 1300 psia and -265°F, coldest (-200°F) expected thrust chamber conditions, and high fuel pump inlet pressure (41 psia)	$t_0 + 0.954$ sec. Main-stage operation was attained at $t_0 + 1.625$ sec. Excessive engine vibration (VSC) was recorded for 66 msec beginning at $t_0 + 0.935$ sec. The initial gas generator outlet temperature peak was 1585°F with a second peak of 1490°F.
37E	S-IVB partial transition firing to evaluate thrust chamber temperature ($25 \pm 15^\circ\text{F}$) effects on engine start transient and relief of launch restraints	Programmed cutoff occurred 700 msec after main-stage signal. Thrust chamber ignition occurred at $t_0 + 0.967$ sec. A minimum fuel pump stall margin of approximately 1000 gpm occurred at about 12,400 rpm during start tank discharge. The maximum gas generator outlet temperature before cutoff was 1295°F.
38A	S-IVB first burn simulation to evaluate engine start transients at AS-502 flight conditions	A successful 32.6-sec firing was conducted. Thrust chamber ignition was recorded at $t_0 + 1.020$ sec. Excessive engine vibration (VSC) was recorded for 31 msec beginning at $t_0 + 1.018$ sec. Main-stage operation was achieved at $t_0 + 2.017$ sec. The maximum gas generator outlet temperature was 1645°F.
38B	S-IVB two-orbit restart simulation to evaluate expected engine start transient at AS-502 flight conditions	This firing was prematurely terminated at $t_0 + 1.24$ sec as the result of a momentary loss of the oxidizer pre valve open limit switch feedback signal. Thrust chamber ignition was recorded at $t_0 + 1.010$ sec. Excessive engine vibration

Firing	Test Objectives	Results
38B (cont'd)		(VSC) was recorded for 51 msec beginning at $t_0 + 1.010$ sec. The maximum gas generator outlet temperature was 1235°F before engine cutoff signal.
38C	S-IVB first burn simulation to evaluate augmented spark igniter and gas generator temperatures at maximum starting energy and fuel inlet pressure and the warmest (-80°F) expected thrust chamber	A 32.6-sec firing was successfully accomplished. The initial gas generator outlet temperature peak was 1580°F with a second peak of 1545°F. No apparent erosion of the augmented spark igniter chamber was detected. Thrust chamber ignition was recorded at $t_0 + 0.968$ sec. Excessive engine vibration (VSC) was recorded for 15 msec beginning at $t_0 + 0.970$ sec. Main-stage operation was achieved at $t_0 + 1.858$ sec.
38D	S-IVB 80-min restart simulation with narrow band relief valve limits on start energy (1300 psia and -265°F) and maximum fuel inlet pressure	A successful 7.6-sec firing was accomplished. Thrust chamber ignition was recorded at $t_0 + 0.955$ sec. Excessive engine vibration (VSC) was recorded for 10 msec beginning at $t_0 + 0.955$ sec. Main-stage operation was achieved at $t_0 + 2.016$ sec. The initial gas generator outlet temperature peak was 1555°F with a second peak of 1825°F.
38E	S-IVB partial transition firing to evaluate thrust chamber temperature ($50 \pm 15^\circ\text{F}$) effect on engine start transient	A programmed cutoff occurred 700 msec after main-stage signal. Thrust chamber ignition was recorded at $t_0 + 0.972$ sec. A minimum fuel pump stall margin of approximately 600 gpm was

<u>Firing</u>	<u>Test Objectives</u>	<u>Results</u>
38E (cont'd)		measured at about 12,300 rpm during start tank discharge. The maximum gas generator outlet temperature was 1255°F before engine cutoff.

The following sections will consist of discussions and analyses of selected firings. The data presented will be those recorded on the digital data acquisition system, except as noted.

4.2 S-IVB FIRST BURN SIMULATION

Comparison of firings 37E and 38E to firing 36E (Ref. 2) showed the effect of thrust chamber thermal conditioning on fuel pump and gas generator start transients, as discussed in subsequent sections. Each of these firings was conducted at similar conditions as shown below:

<u>Firing</u>	<u>36E</u>	<u>37E</u>	<u>38E</u>
Fuel Lead, sec	3.001	3.020	3.001
Fuel Pump Inlet Pressure, psia, at Engine Start	27.9	28.6	27.9
Fuel Pump Inlet Temperature, °F, at Engine Start	-420.9	-421.4	-420.9
Oxidizer Pump Inlet Pressure, psia, at Engine Start	44.4	45.5	45.3
Oxidizer Pump Inlet Temperature, °F, at Engine Start	-294.3	-294.8	-294.4
Start Tank Pressure, psia, at Engine Start	1388	1380	1394
Start Tank Temperature, °F, at Engine Start	-199	-207	-203
Average Thrust Chamber Temperature, °F, at Engine Start/at t_0	-14/-91	19/-66	51/-30
Average Crossover Duct Temperature, °F, at Engine Start	22	22	20

Each of these firings was a partial transition test with a programmed cutoff occurring at approximately 700 msec after the main-stage solenoid was energized.

4.2.1 Thrust Chamber Thermal Conditioning Effects on Fuel Pump Operation

The operation of the fuel pump was directly affected during start tank discharge by thrust chamber thermal conditioning. This resulted from thrust chamber temperature directly affecting the resistance to fuel flow through the thrust chamber. The warmest conditioned thrust chamber provided the greatest resistance to fuel flow, as evidenced by the sharp reduction in fuel pump flow coefficient (Fig. 49) during start tank discharge. This reduction occurred earliest with the warmest conditioned thrust chamber. The reduction in fuel flow resulted in an increase in fuel pump discharge pressure, which is shown by the increase in fuel pump head rise coefficient (Fig. 50). The resulting effect of thrust chamber thermal conditioning on fuel pump operation was to reduce the minimum stall margin during start tank discharge (Fig. 51); the warmest thrust chamber resulted in a stall margin of about 600 rpm at approximately 12,300 rpm.

4.2.2 Thrust Chamber Thermal Conditioning Effects on Gas Generator Operation

Gas generator operation during start tank discharge was directly affected by thrust chamber thermal conditioning. This was true since the fuel injection pressure into the gas generator was directly related to the fuel pump discharge pressure. The previous section (Section 4.2.1) showed that the pump discharge pressure increased with increases in thrust chamber conditioning temperature. This resulted in increased fuel injection pressure (Fig. 52) into the gas generator during start tank discharge as the thrust chamber conditioning temperature was increased. This, in effect, provided better quality fuel in the gas generator which reduced the mixture ratio. This was reflected in the reduction of the initial gas generator outlet temperature peak from 1585 to 1255°F (Fig. 53). Thus, an increase in thrust chamber conditioning temperature from -14 to 50°F reduced the initial gas generator outlet temperature peak about 330°F.

4.3 S-IVB 80-MIN ORBITAL COAST RESTART SIMULATION

Comparison of firing 37D to 38D showed the effect of thrust chamber thermal conditioning effects on fuel pump and gas generator start transients, as discussed in subsequent sections. Both of these firings were conducted at conditions predicted for an 80-min orbital coast restart as shown:

<u>Firing</u>	<u>36D</u>	<u>37D</u>	<u>38D</u>
Fuel Lead, sec	7.92	7.92	7.92
Fuel Pump Inlet Pressure, psia, at Engine Start	26.6	41.0	41.0
Fuel Pump Inlet Temperature, °F, at Engine Start	-420.6	-420.6	-421.1
Oxidizer Pump Inlet Pressure, psia, at Engine Start	45.0	45.0	45.1
Oxidizer Pump Inlet Temperature, °F, at Engine Start	-294.8	-294.7	-294.3
Start Tank Pressure, psia, at Engine Start	1298	1296	1295
Start Tank Temperature, °F, at Engine Start	-266	-276	-269
Average Thrust Chamber Temperature, °F, at Engine Start/at t_0	-210/-362	-228/-366	36/-286
Crossover Duct Temperature, °F, at Engine Start (TFTD-2/-3/-8)	450/174/408	409/171/384	438/173/396

4.3.1 Thrust Chamber Thermal Conditioning Effects on Fuel Pump Operation

The initial resistance to fuel flow through the thrust chamber by the warmer conditioned chamber was greatly reduced by the 8-sec fuel lead. The average thrust chamber temperatures after the fuel lead (t_0) were -366 and -286°F for firings 37D and 38D, respectively. The resistance to fuel flow was essentially equal for both firings, as shown in Fig. 54. However, the warmer conditioned (-286°F) thrust chamber resulted in the higher fuel pump head rise coefficient during start tank discharge (Fig. 55). The net result was to reduce the minimum fuel pump stall margin from about 2360 to 2160 gpm at approximately 13,500 rpm during start tank discharge, Fig. 56.

4.3.2 Thrust Chamber Thermal Conditioning Effects on Gas Generator Operation

Both firings 37D and 38D were conducted with a fuel pump inlet pressure of 41.0 psia at engine start. This resulted in high gas generator fuel injection pressure and better quality fuel in the gas generator chamber. Ignition in the chamber occurred at $t_0 + 0.660$ sec for firing 38D. Ignition during firing 37D was characterized by apparent low energy combustion from $t_0 + 0.670$ sec to $t_0 + 0.740$ sec, as shown by gas generator chamber pressure in Fig. 57.

Thrust chamber ignition, which provides the mechanism for terminating the initial gas generator outlet temperature peak, occurred at $t_0 + 0.955$ sec for both firings. The initial gas generator outlet temperature peak for firing 37D (1585°F) was about 30°F hotter than for firing 38D (1555°F). This is shown in Fig. 58. Therefore, an increase in thrust chamber conditioning temperature from -366 to -286°F resulted in a 30°F decrease in the initial gas generator outlet temperature peak.

4.3.3 Fuel Pump Inlet Pressure Effect on Fuel Pump Operation

The effect of fuel inlet pressure on fuel pump operation during start tank discharge could be seen by a comparison of firing 36D to 37D. From the data tabulated in Section 4.3, all starting conditions were essentially equal with the exception of fuel pump inlet pressure at engine start. The inlet pressure was 26.5 and 41.0 psia for firings 36D and 37D, respectively.

Oxidizer pump operation was the same for both firings; the peak turbine speed was approximately 3850 rpm at $t_0 + 0.560$ sec during start tank discharge. The average oxidizer pump discharge pressure (data from FM system) at $t_0 + 0.560$ was 305 psia for both firings.

The fuel pump speed at $t_0 + 0.560$ sec was about 660 rpm higher for firing 37D (13,565 rpm) than for firing 36D. This resulted in an average pump discharge pressure (data from FM system) of 100 psia at $t_0 + 0.560$ sec for firing 37D; this was about 40 psi greater than for firing 36D. Fuel pump head rise coefficient was lower for firing 37D during start tank discharge, as shown in Fig. 59. The flow coefficient (Fig. 60) was correspondingly higher for 37D at this same time period. The net effect of the increase from 26.5 to 41.0 psia fuel pump inlet pressure was to increase the minimum stall margin during start tank discharge from 1720 to 2000 gpm, as shown in Fig. 61.

4.3.4 Fuel Pump Inlet Pressure Effect on Gas Generator Operation

Higher fuel pump inlet pressure for firing 37D resulted in a higher fuel injection pressure into the gas generator than for firing 36D, as shown in Fig. 62. This provided a better quality fuel in the gas generator for firing 37D. With oxidizer injection pressure equal for both firings, the result was a lower mixture ratio in the gas generator chamber during firing 37D. Both firings were characterized by apparent low energy combustion; firing 37D from $t_0 + 0.670$ to 0.740 sec and firing 36D from $t_0 + 0.650$ to 0.750 sec. This was reflected in the gas generator chamber pressure as shown in Fig. 63.

Thrust chamber ignition occurred at $t_0 + 0.955$ sec for both firings. This provided the mechanism for terminating the initial gas generator outlet temperature (Fig. 64) at 1585°F for firing 37D about 575°F colder than for firing 36D. Therefore, an increase in fuel pump inlet conditioning pressure at engine start from 26.5 to 41.0 psia resulted in a decrease in the initial gas generator outlet temperature of 575°F .

4.4 S-IVB 6-HR ORBITAL COAST RESTART

Simulated restart conditions expected for the S-IVB stage engine after a 6-hr orbital coast are characterized by low starting energy. Both firings 37C and 36A (Ref. 2) were S-IVB 6-hr orbital coast restart simulations and were conducted at essentially the same starting conditions as shown below:

Firing	36A	37C
Fuel Lead, sec	7.92	7.92
Fuel Pump Inlet Pressure, psia, at Engine Start	26.8	27.0
Fuel Pump Inlet Temperature, $^\circ\text{F}$, at Engine Start	-421.4	-421.2
Oxidizer Pump Inlet Pressure, psia, at Engine Start	33.6	33.5
Oxidizer Pump Inlet Temperature, $^\circ\text{F}$, at Engine Start	-294.6	-294.8
Start Tank Pressure, psia, at Engine Start	1250	1237
Start Tank Temperature, $^\circ\text{F}$, at Engine Start	-139	-146

Firing	36A	37C
Average Thrust Chamber Temperature, °F, at Engine Start/at t_0	-182/-356	-231/-367
Average Crossover Duct Temperature, °F, at Engine Start	-93	-99

Thrust chamber ignition occurred at $t_0 + 1.090$ sec for firing 37C and at $t_0 + 1.079$ sec for firing 36A. When compared with ignition time for first burn and 80-min orbital coast restart simulations, the 6-hr orbital coast ignition time was delayed about 90 msec. Thrust chamber pressure attained 550 psia at $t_0 + 2800$ sec for firings 37C and 36A, which is slow when compared with first burn and 80-min orbital coast restart simulations.

The initial gas generator outlet temperature peak was 890°F for firing 37C (Fig. 18f). This was about 10°F warmer than recorded for firing 36A. The 10°F difference resulted from lower resistance to fuel flow through the thrust chamber by the colder (-367°F) conditioned thrust chamber (firing 37C). This decreased the fuel available to the gas generator and thereby increased the mixture ratio in the gas generator.

The 10°F difference in the thrust chamber conditioning temperatures at t_0 did not significantly affect fuel pump operation. Thus firing 37C (Fig. 19) is representative of fuel pump start transient performance for firing 36A. The engine start transients for firing 37C (Fig. 18) are also representative of the start transients which existed for firing 36A.

4.5 POST-TEST INSPECTION

Inspection after the completion of tests J4-1801-37 and 38 revealed no apparent engine component damage.

SECTION V SUMMARY OF RESULTS

The results of testing the J-2 rocket engine in Test Cell J-4 during tests J4-1801-37 and 38 conducted on April 16 and 23, 1968, respectively, are summarized as follows:

1. The engine started with the thrust chamber conditioned to +50°F at engine start (firing 38E), in conjunction with a

3-sec fuel lead for an S-IVB first burn mission. The minimum fuel pump stall margin was about 600 gpm at approximately 12,300 rpm.

2. An increase in average thrust chamber conditioning temperature at engine start from -14°F (firing 36E) to 50°F (firing 38E) for an S-IVB first burn reduced the initial gas generator outlet temperature peak about 330°F .
3. An increase in average thrust chamber conditioning temperature at engine start from -366°F (firing 37D) to -286°F (firing 38D) for an S-IVB 80-min orbital coast simulation resulted in a 30°F decrease in the initial gas generator outlet temperature peak.
4. A change in the fuel pump inlet conditioning pressure at engine start from 26.6 psia (firing 36D) to 41.0 psia (firing 37D) reduced the initial gas generator outlet temperature peak 575°F .
5. A minimum starting energy S-IVB 6-hr orbital coast restart (firing 37C) simulation was satisfactorily accomplished. The initial gas generator outlet temperature peak was 890°F .
6. An S-IVB first burn simulation (firing 37A) with minimum starting energy resulted in a minimum fuel pump stall margin of 400 gpm at about 18,000 rpm.

REFERENCES

1. Dubin, M., Sissenwine, N., and Wexler, H. U. S. Standard Atmosphere, 1962. December 1962.
2. Franklin, D. E. "Altitude Testing of the J-2 Rocket Engine in Propulsion Engine Test Cell (J-4) (Tests J4-1801-34 through J4-1801-36)." AEDC-TR-68-176, October 1968.
3. "J-2 Rocket Engine, Technical Manual Engine Data." R-3825-1, August 1965.
4. Test Facilities Handbook (7th Edition). "Large Rocket Facility, Vol. 3." Arnold Engineering Development Center, July 1968.

APPENDIXES

- I. ILLUSTRATIONS**
- II. TABLES**
- III. INSTRUMENTATION**
- IV. METHODS OF CALCULATION (PERFORMANCE PROGRAM)**

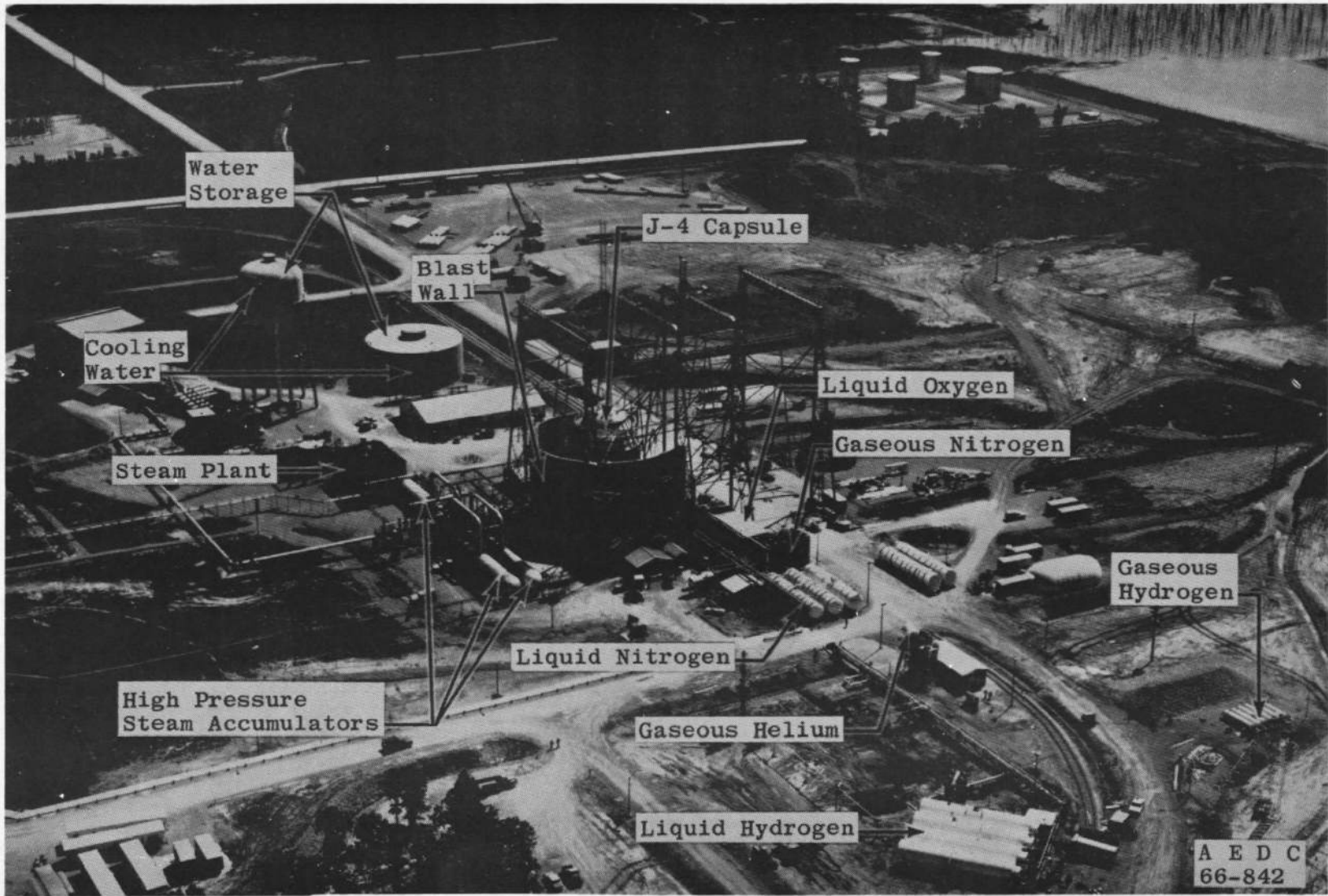

Fig. 1 Test Cell J-4 Complex

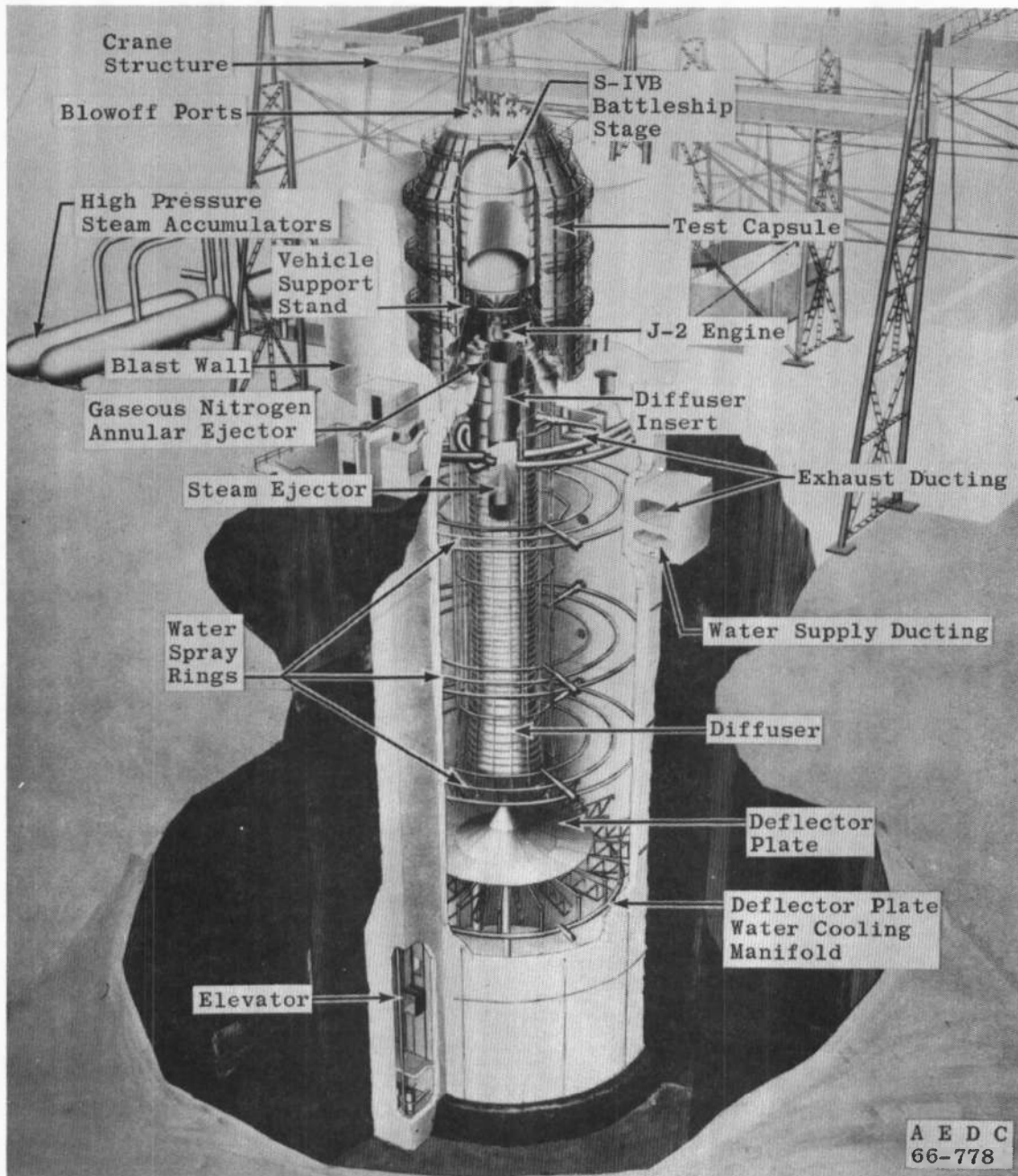

Fig. 2 Test Cell J-4, Artist's Conception

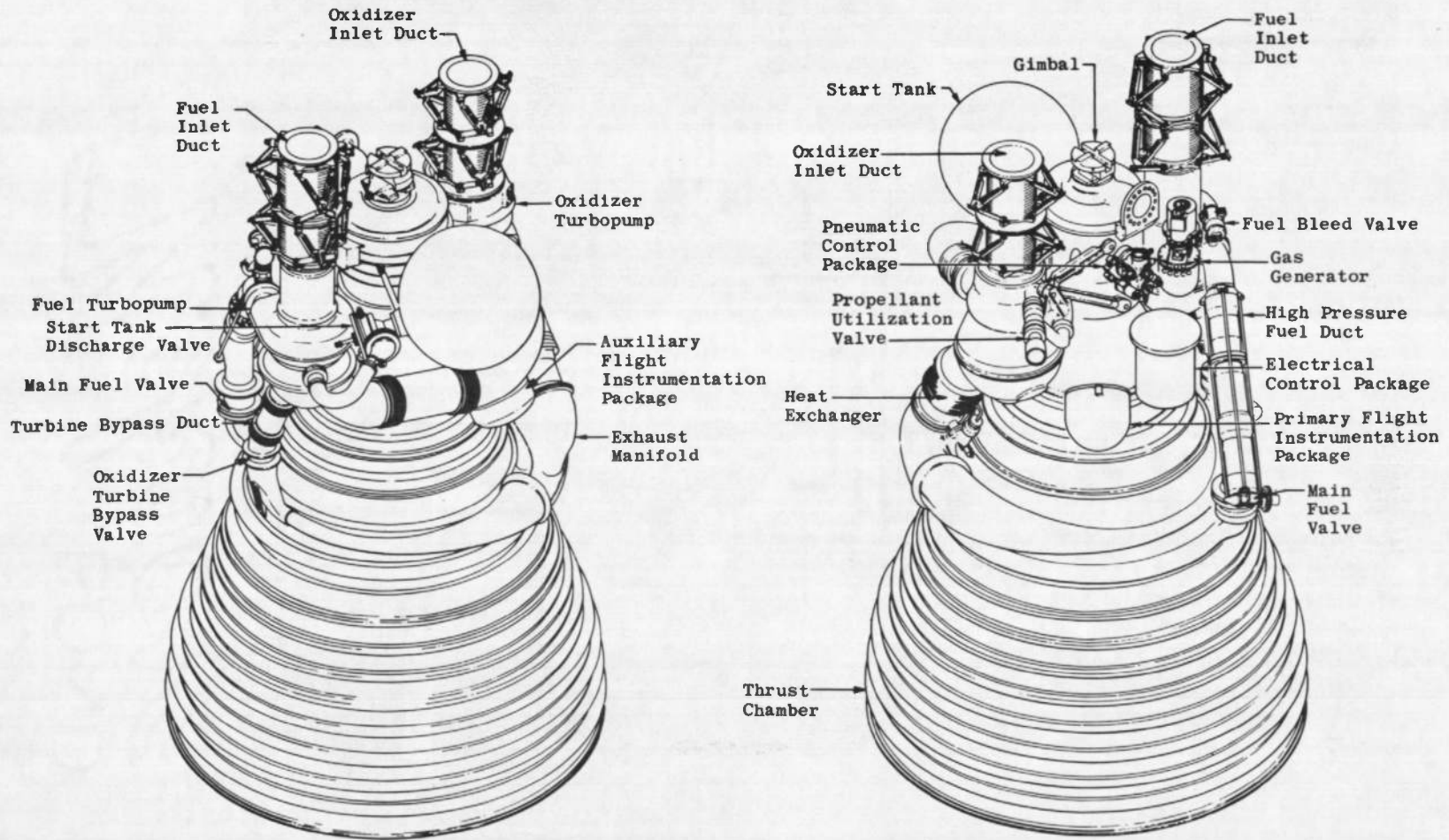

Fig. 3 Engine Details

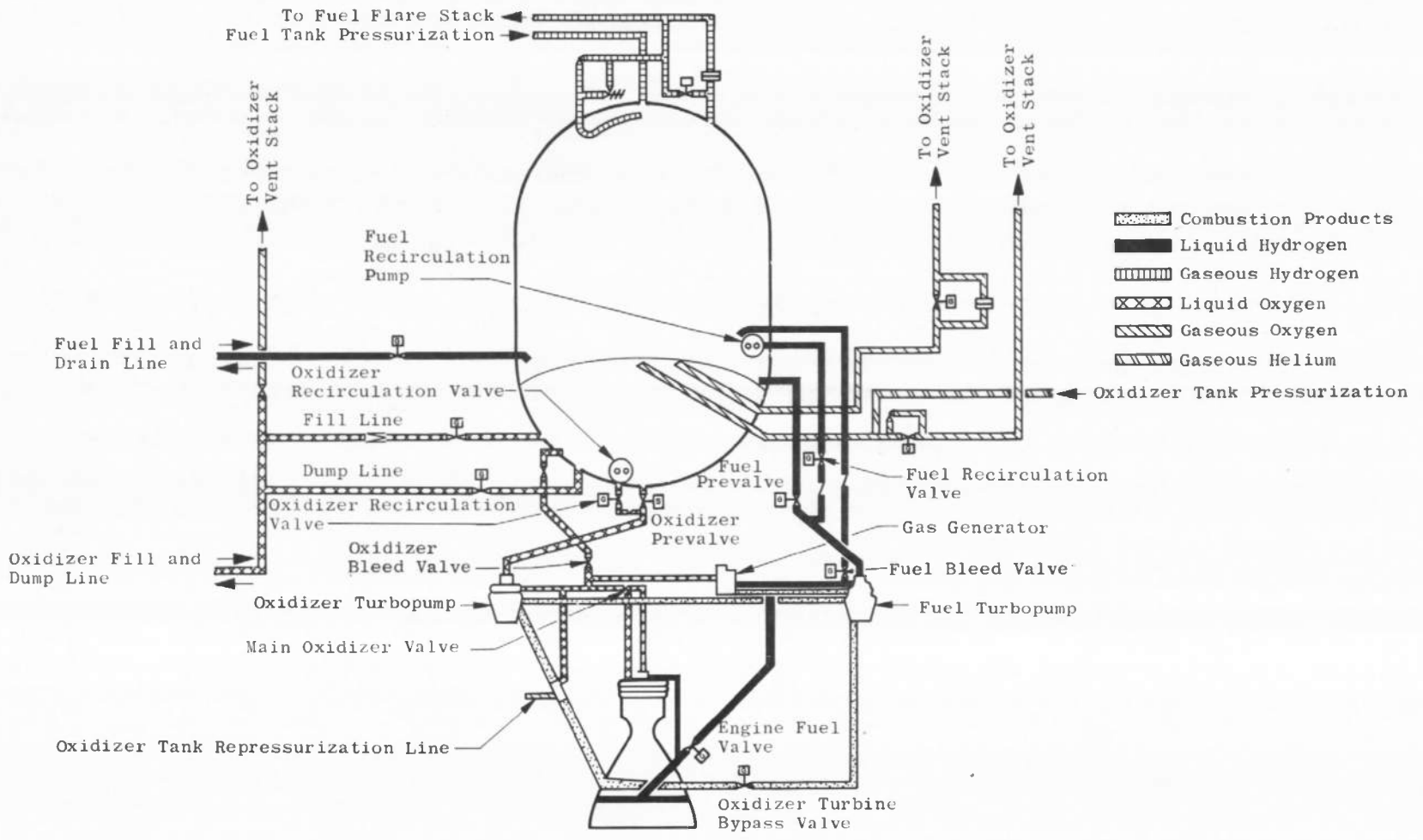

Fig. 4 S-IVB Battleship Stage/J-2 Engine Schematic

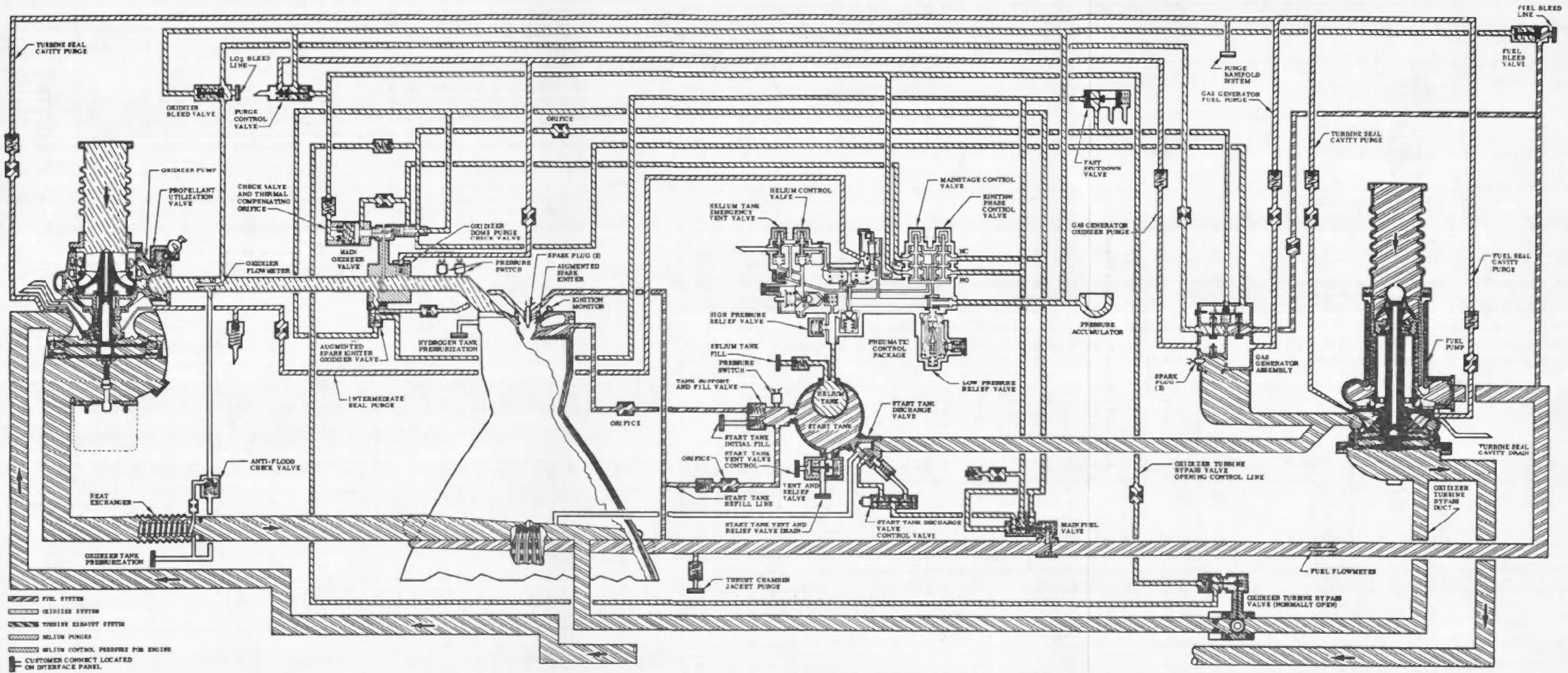

Fig. 5 Engine Schematic

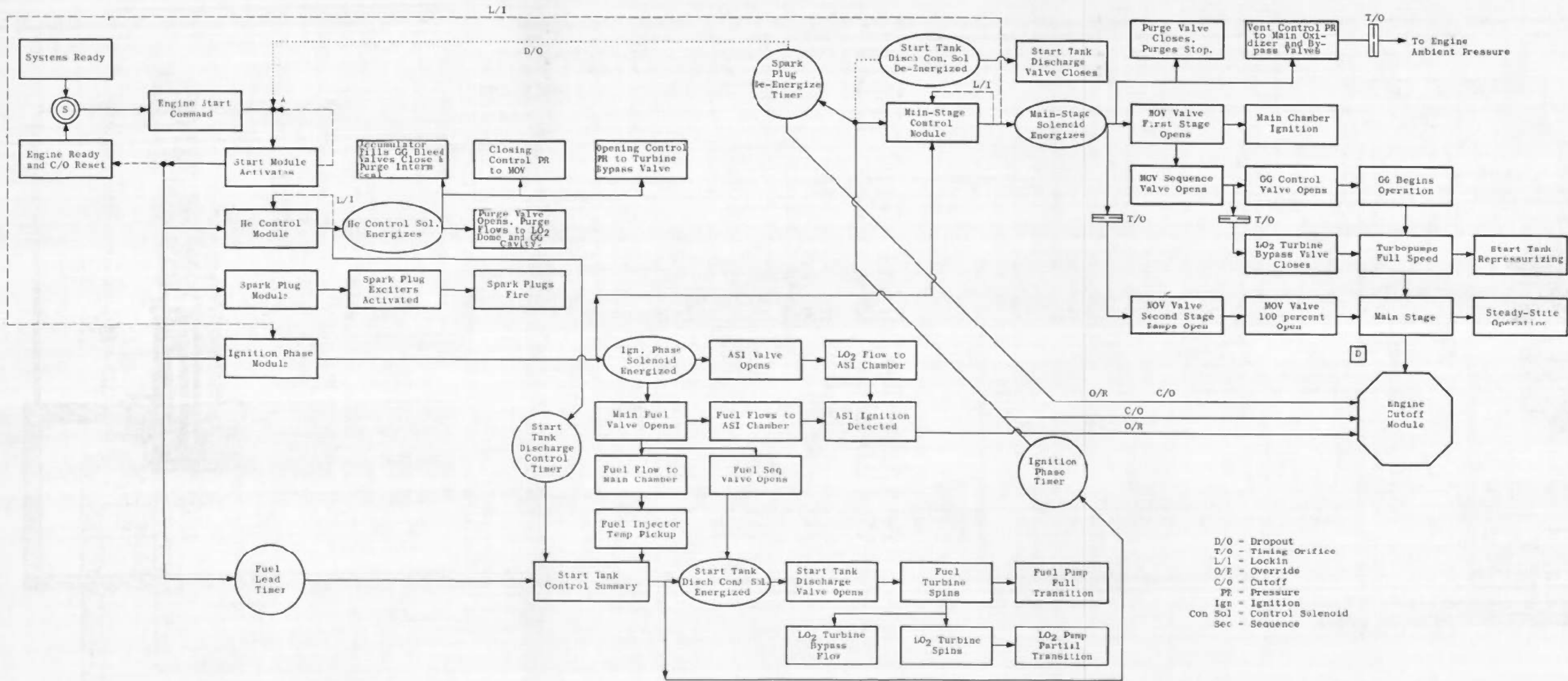
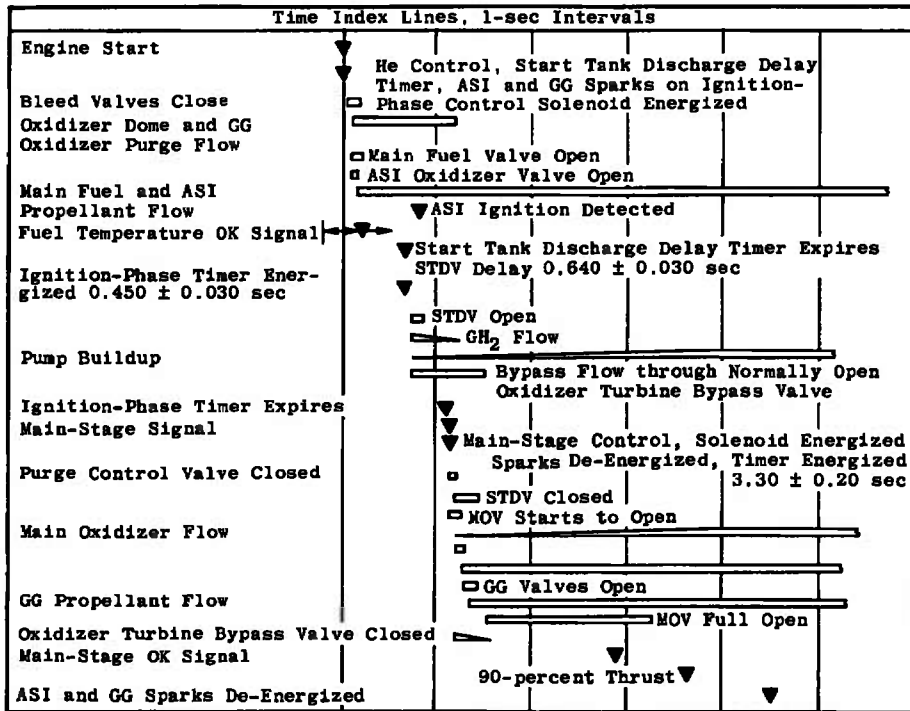
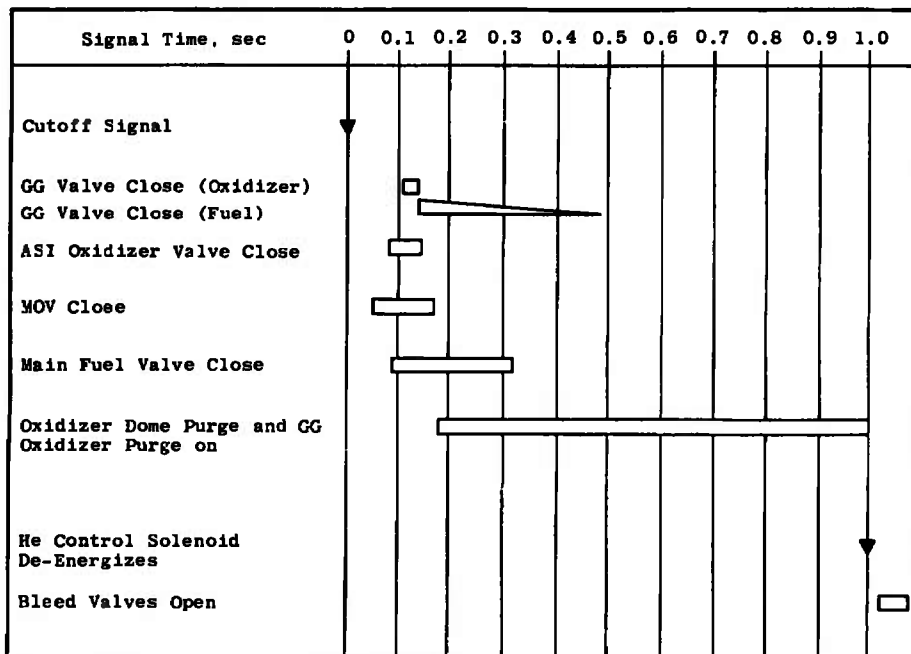

Fig. 6 Engine Start Logic Schematic



a. Start Sequence



b. Shutdown Sequence

Fig. 7 Engine Start and Shutdown Sequence

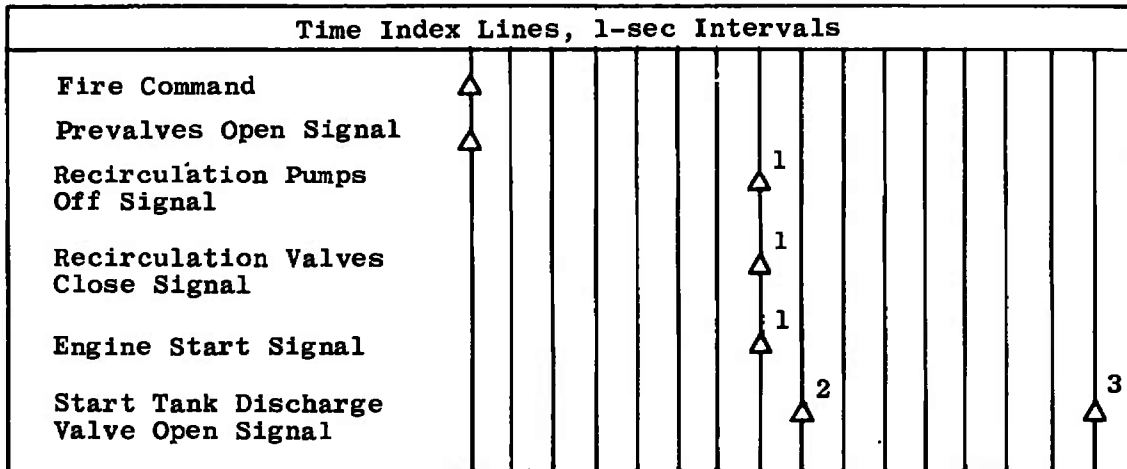

¹Nominal Occurrence Time (Function of Prevalves Opening Time)

²One-sec Fuel Lead (S-II/S-V and S-IVB/S-IB)

³Eight-sec Fuel Lead (S-IVB/S-V and S-IB Orbital Restart)

c. Normal Logic Start Sequence

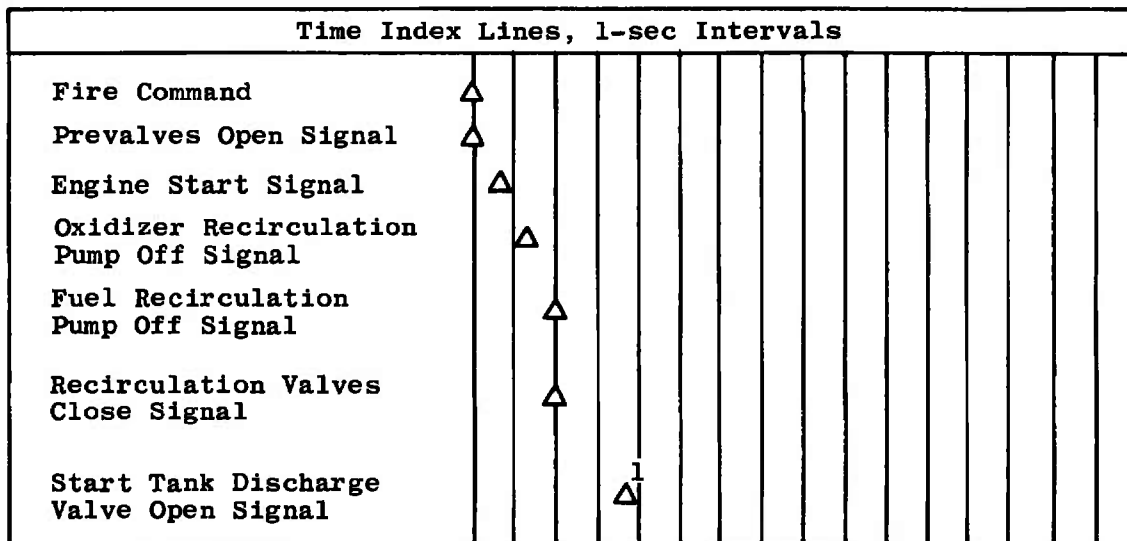

¹Three-sec Fuel Lead (S-IVB/S-V First Burn)

d. Auxiliary Logic Start Sequence

Fig. 7 Concluded

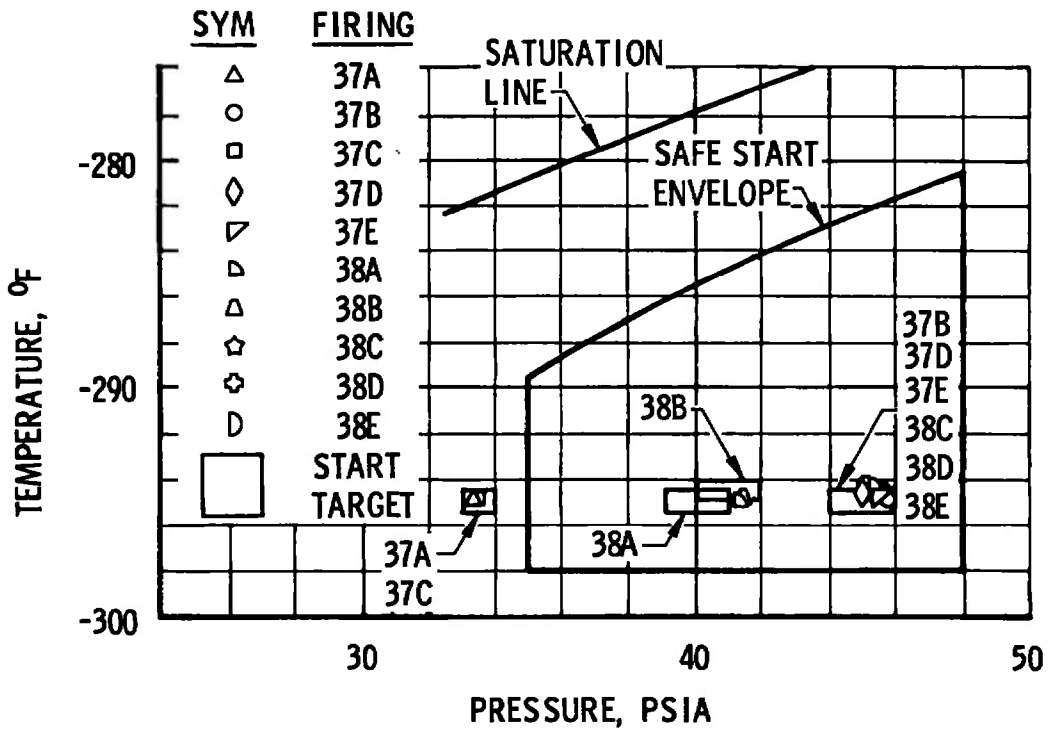

a. Oxidizer Pump Inlet

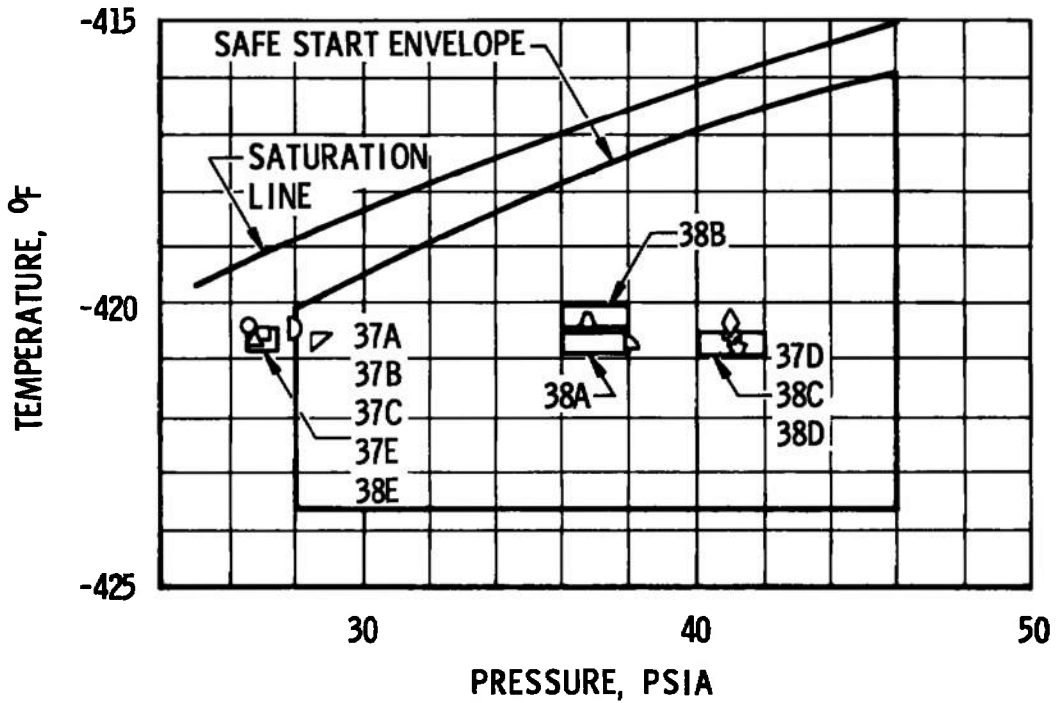

b. Fuel Pump Inlet

Fig. 8 Engine Start Conditions for the Pump Inlets, Start Tank, and Helium Tank

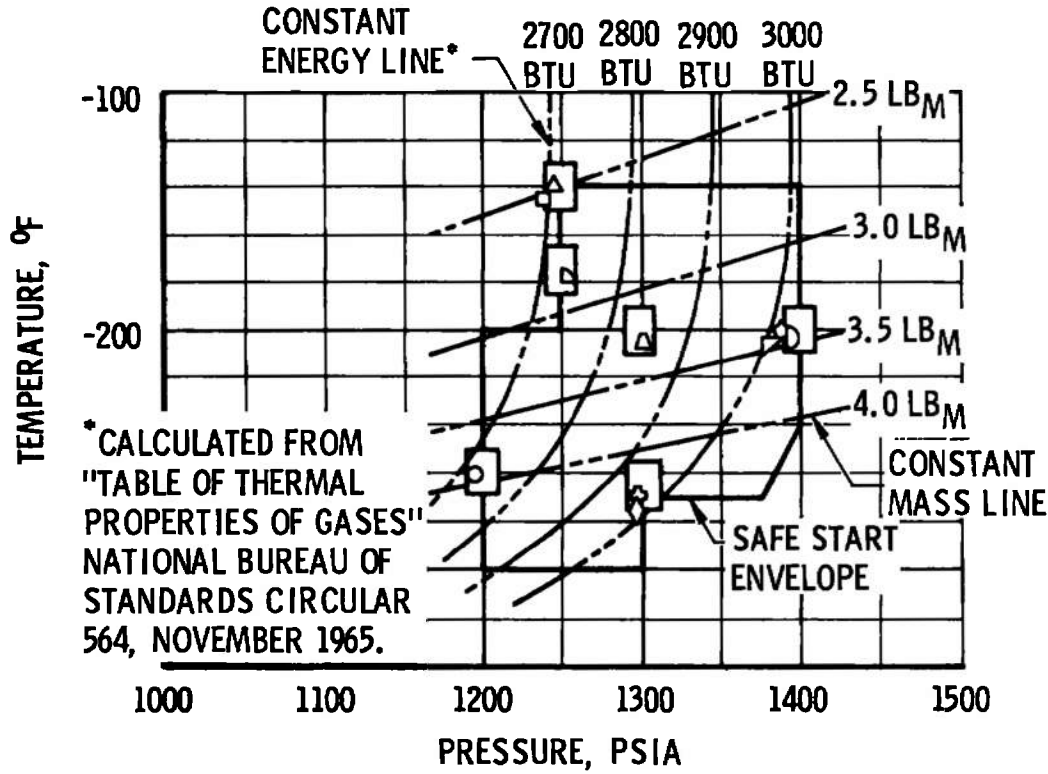

c. Start Tank

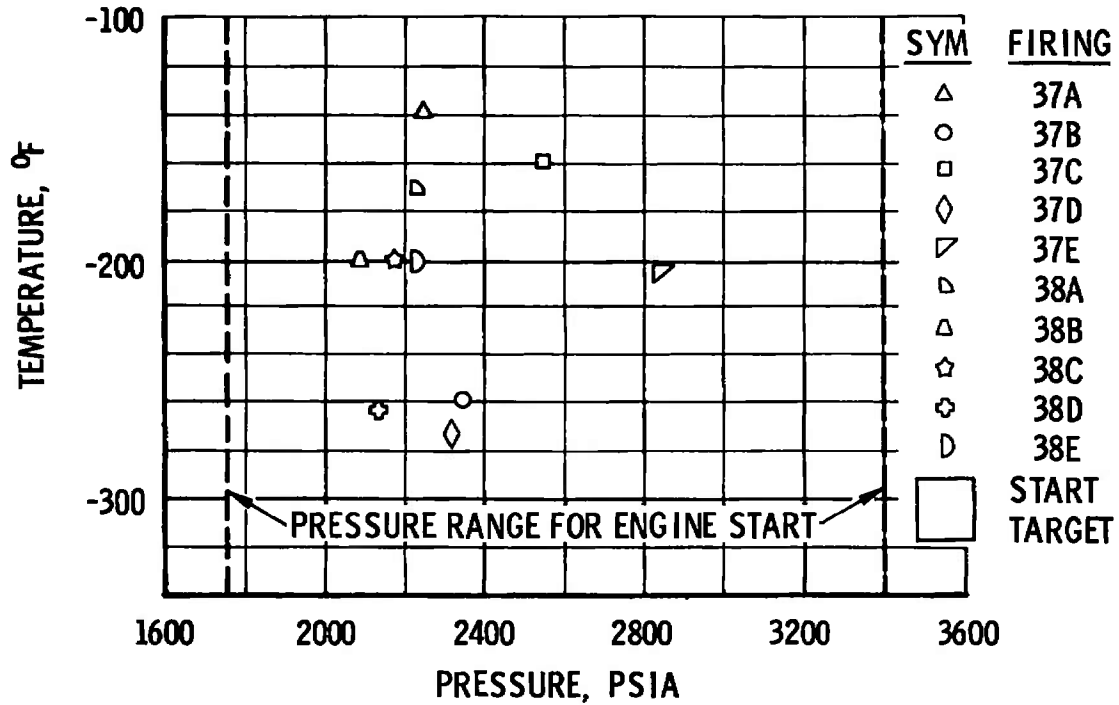

d. Helium Tank

Fig. 8 Concluded

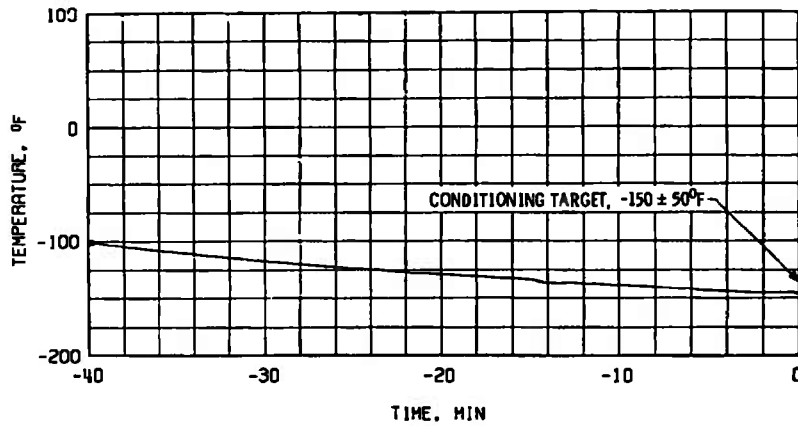

a. Main Oxidizer Valve Second-Stage Actuator, TSOVC-1

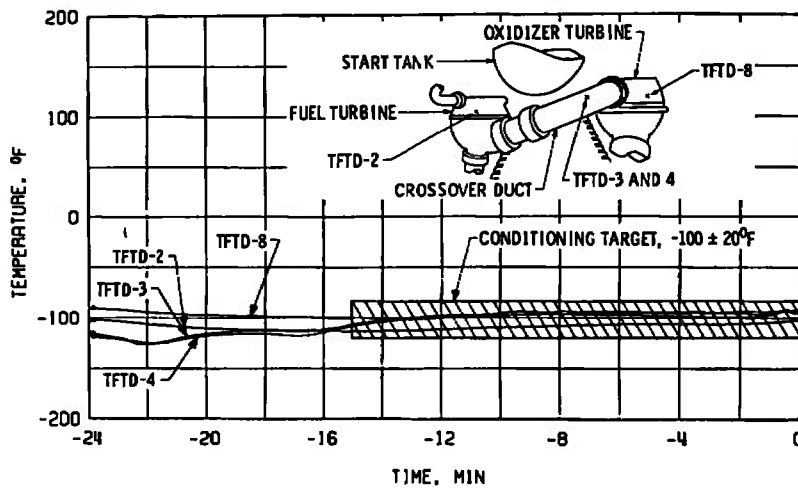

b. Crossover Duct, TFTD

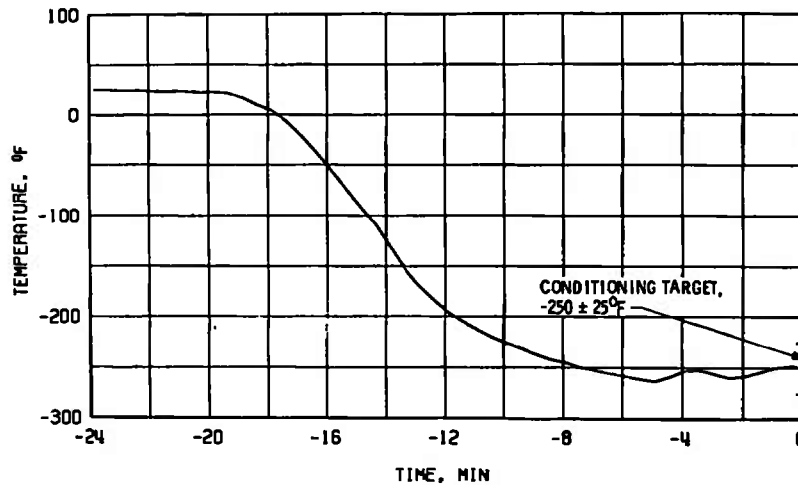

c. Thrust Chamber Throat, TTC-1P

Fig. 9 Thermal Conditioning History of Engine Components, Firing 37A

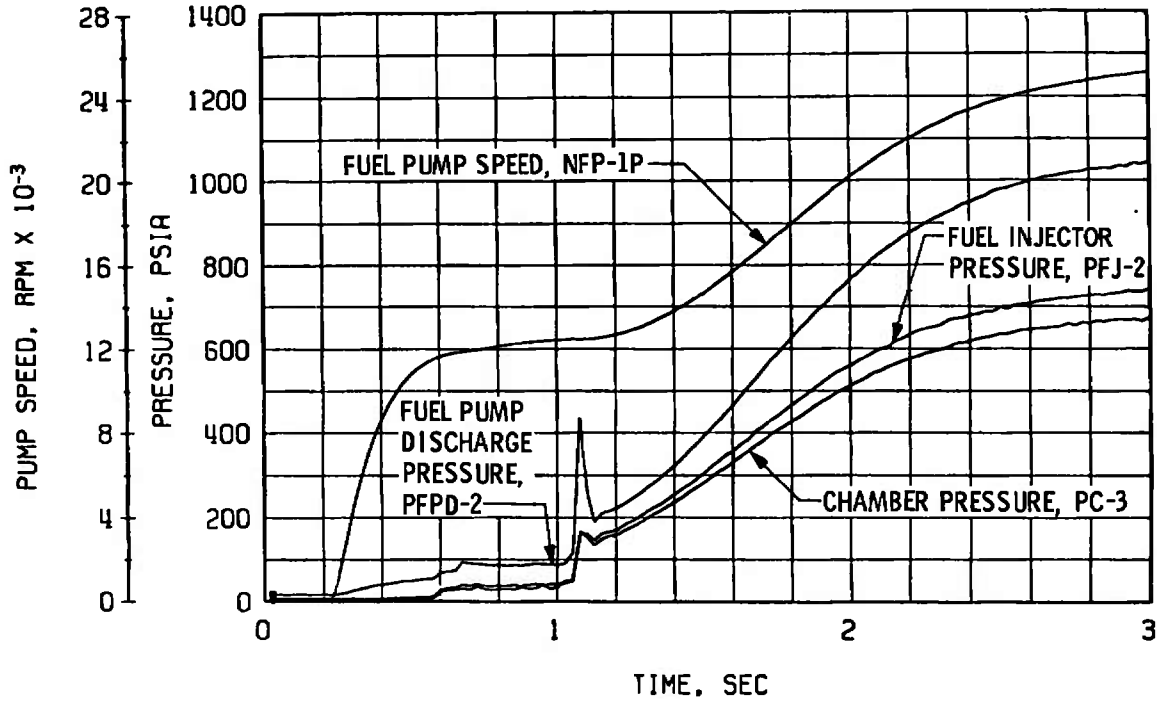

a. Thrust Chamber Fuel System, Start

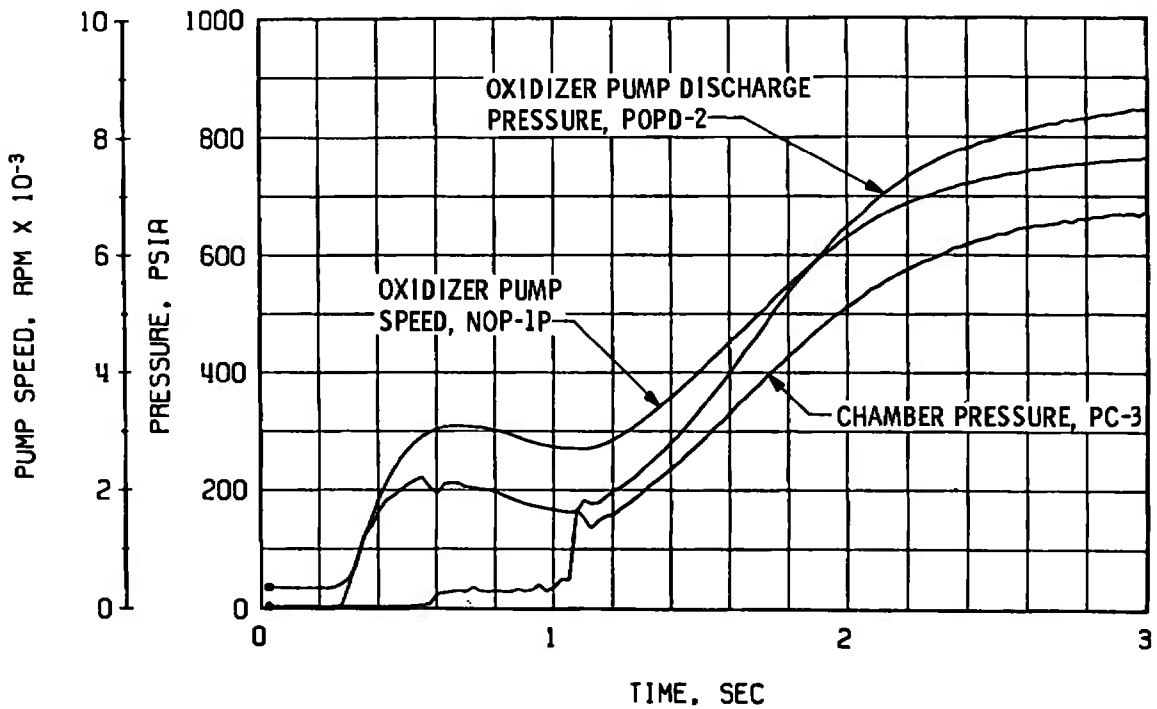

b. Thrust Chamber Oxidizer System, Start

Fig. 10 Engine Transient Operation, Firing 37A

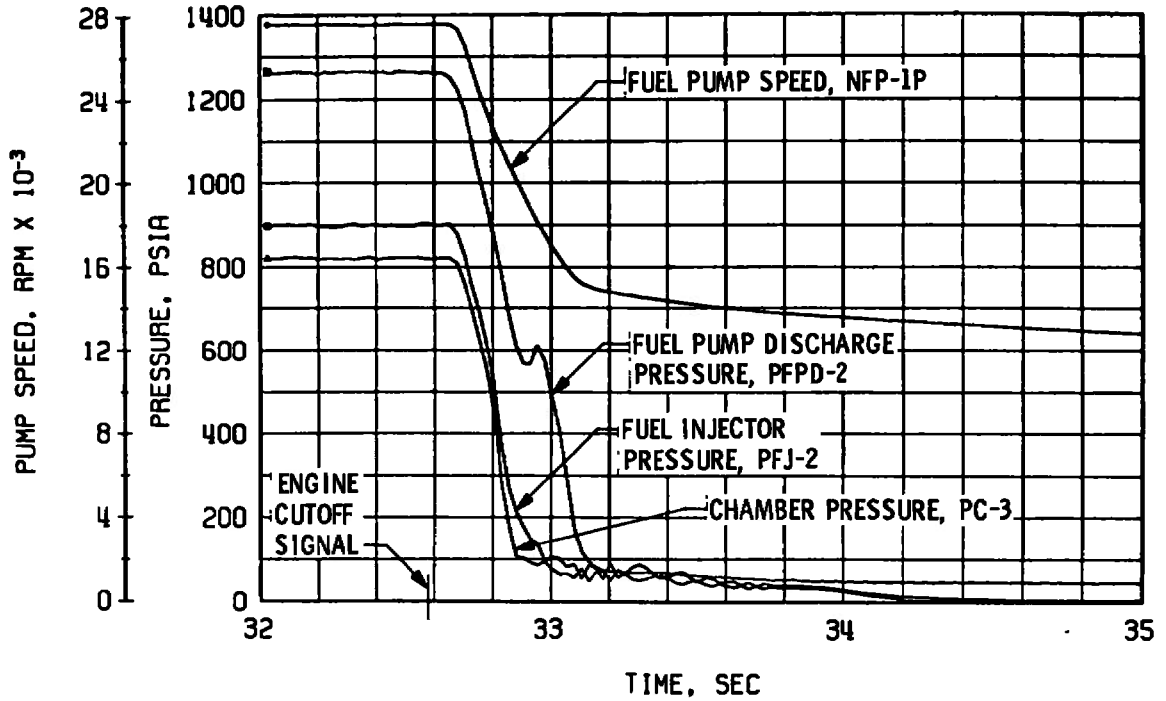

c. Thrust Chamber Fuel System, Shutdown

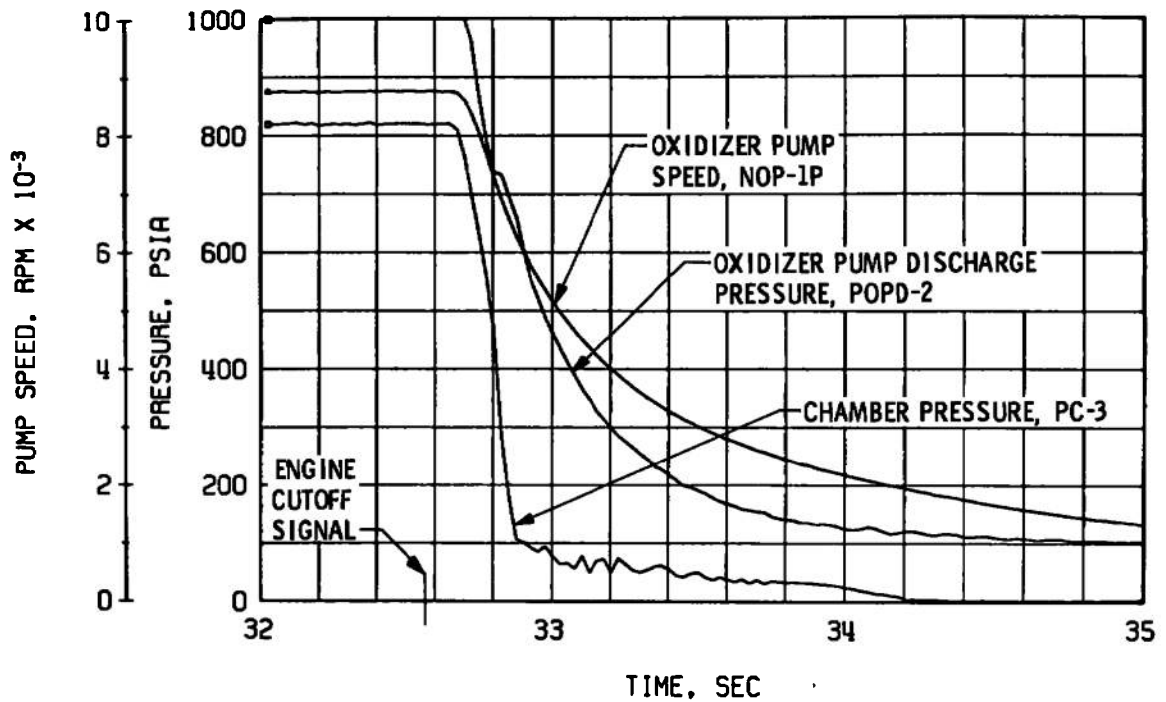

d. Thrust Chamber Oxidizer System, Shutdown

Fig. 10 Continued

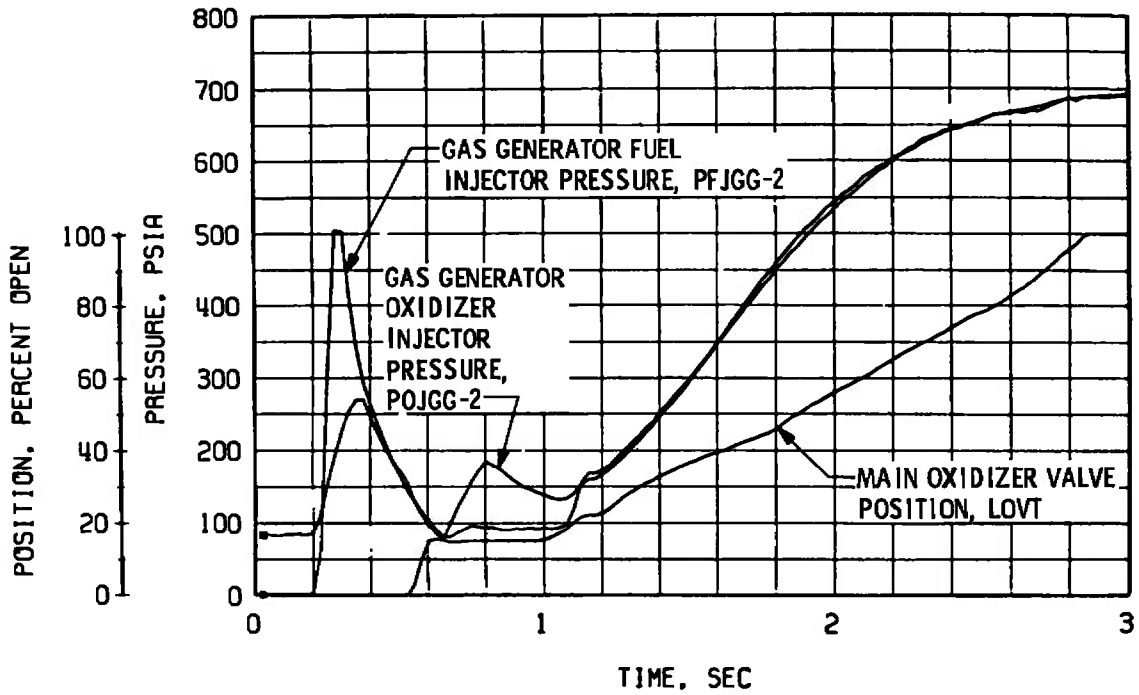

e. Gas Generator Injector Pressures and Main Oxidizer Valve Position, Start

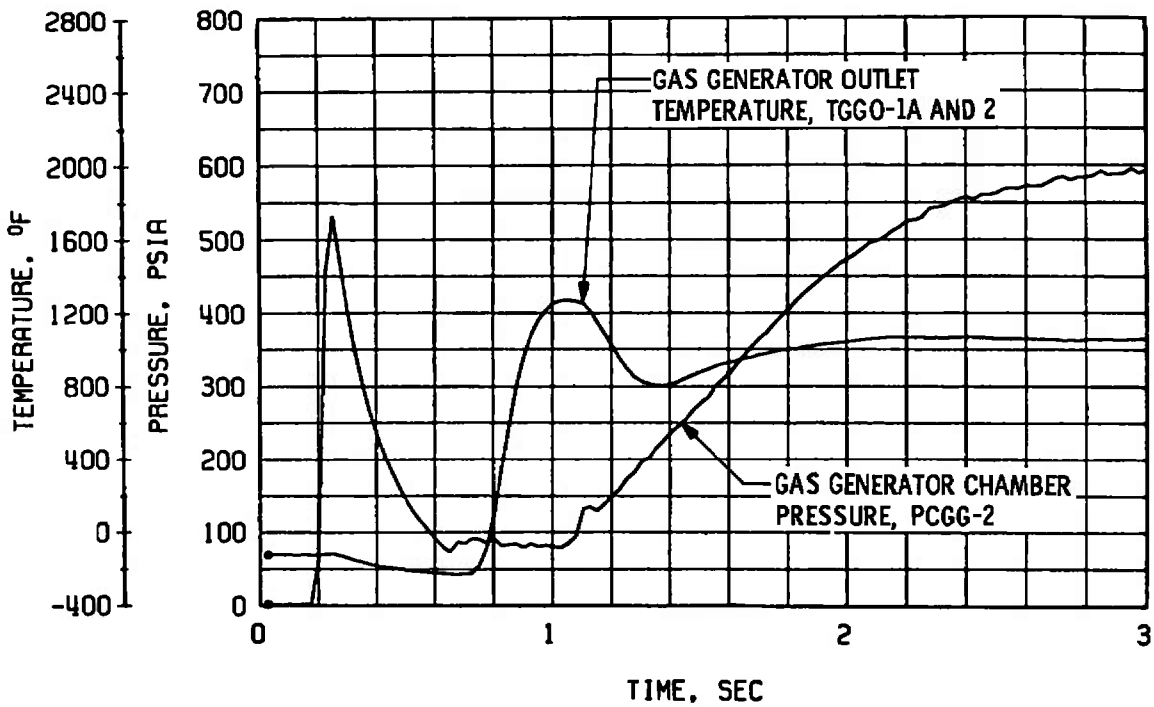

f. Gas Generator Chamber Pressure and Temperature, Start

Fig. 10 Continued

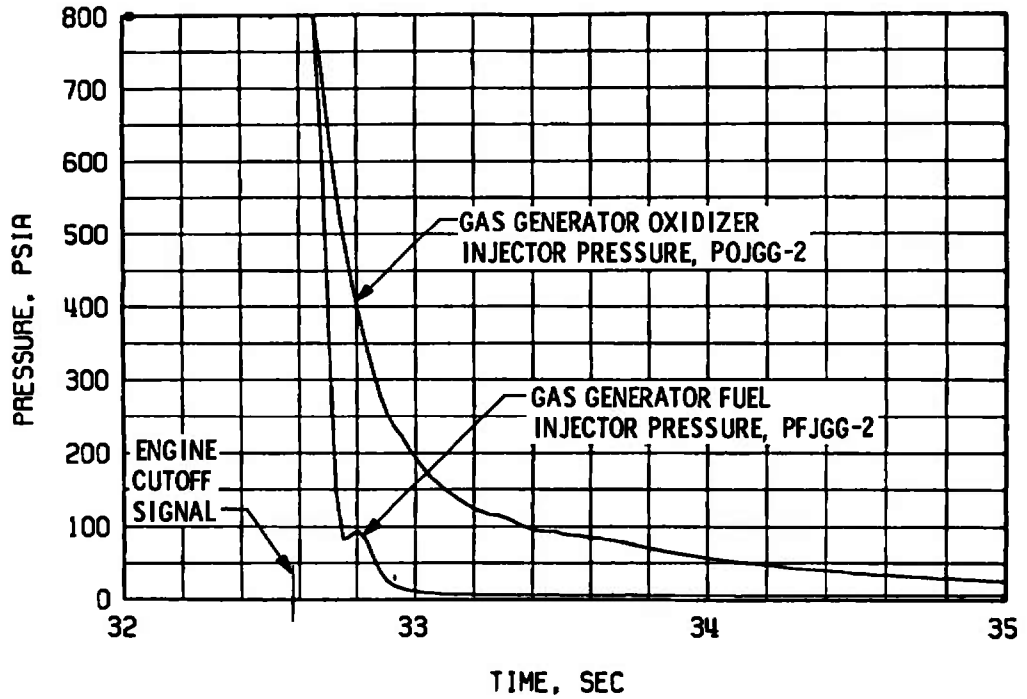

g. Gas Generator Injector Pressures, Shutdown

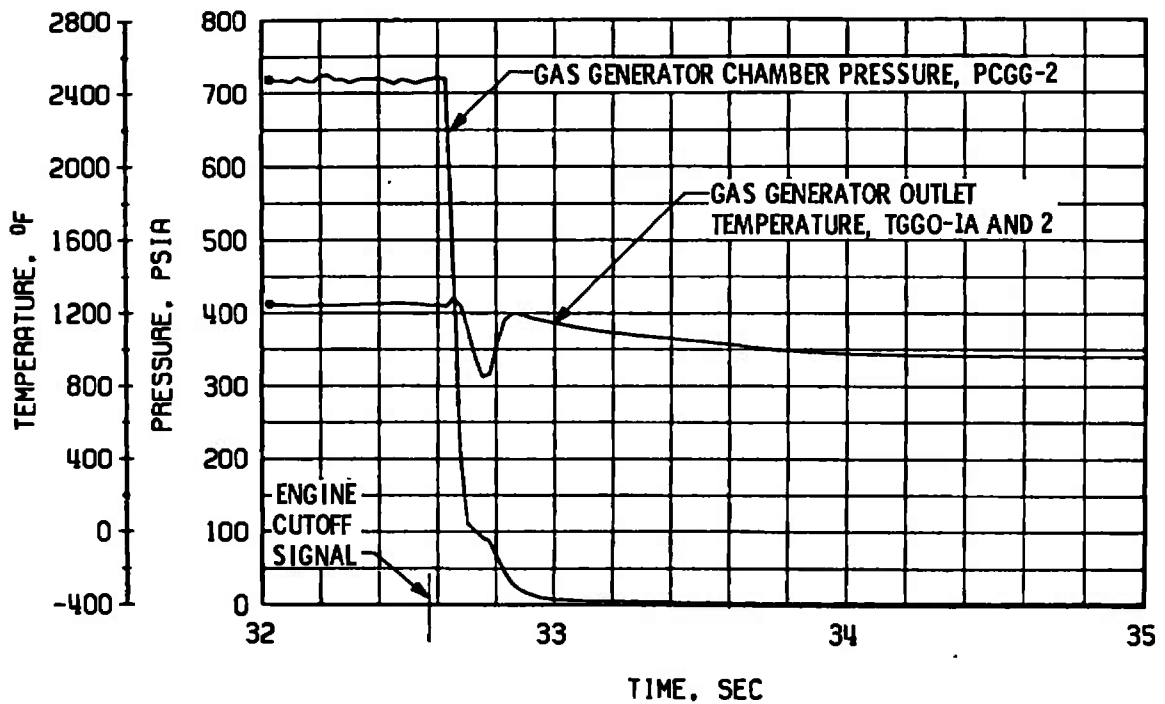

h. Gas Generator Chamber Pressure and Temperature, Shutdown

Fig. 10 Concluded

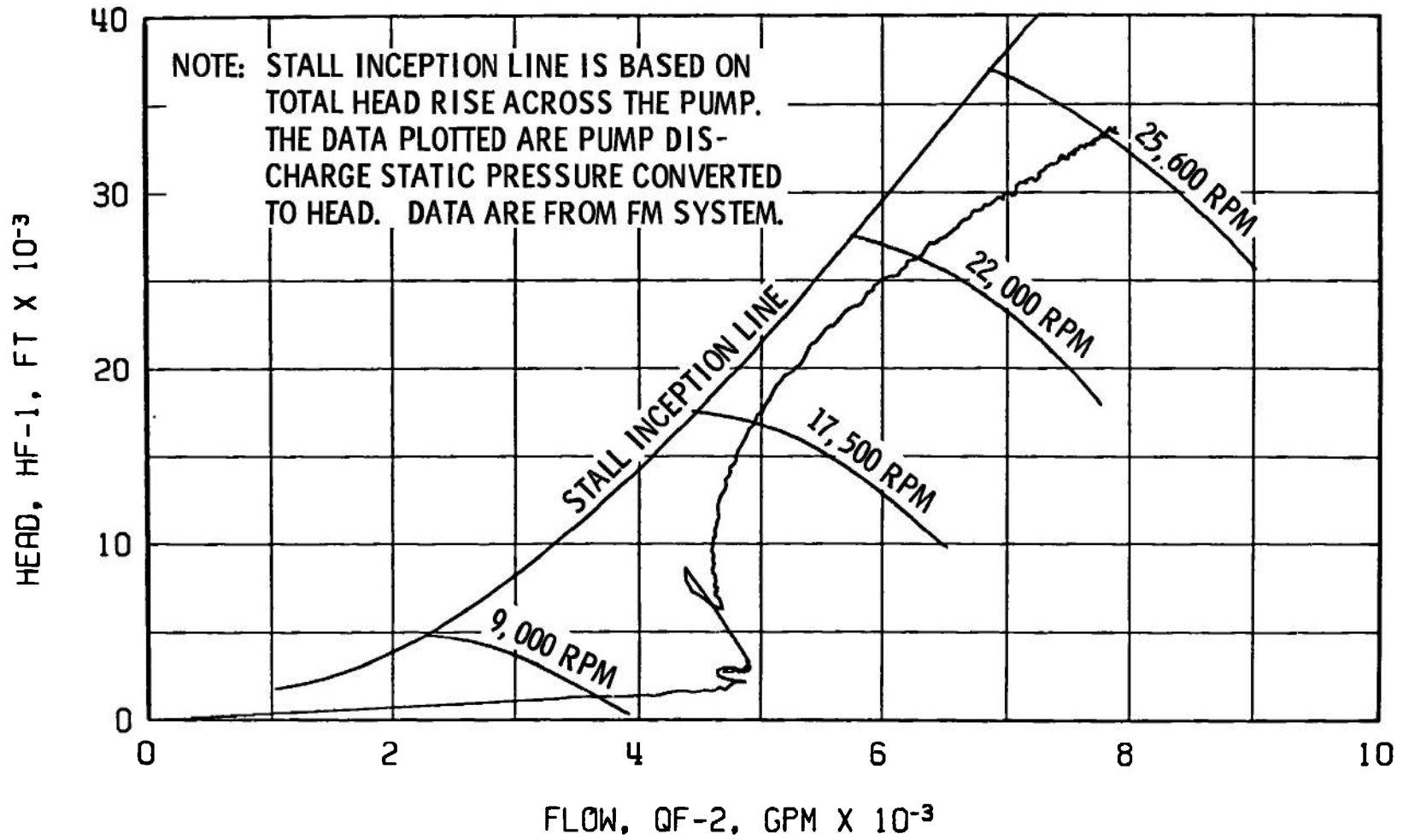

Fig. 11 Fuel Pump Start Transient Performance, Firing 37A

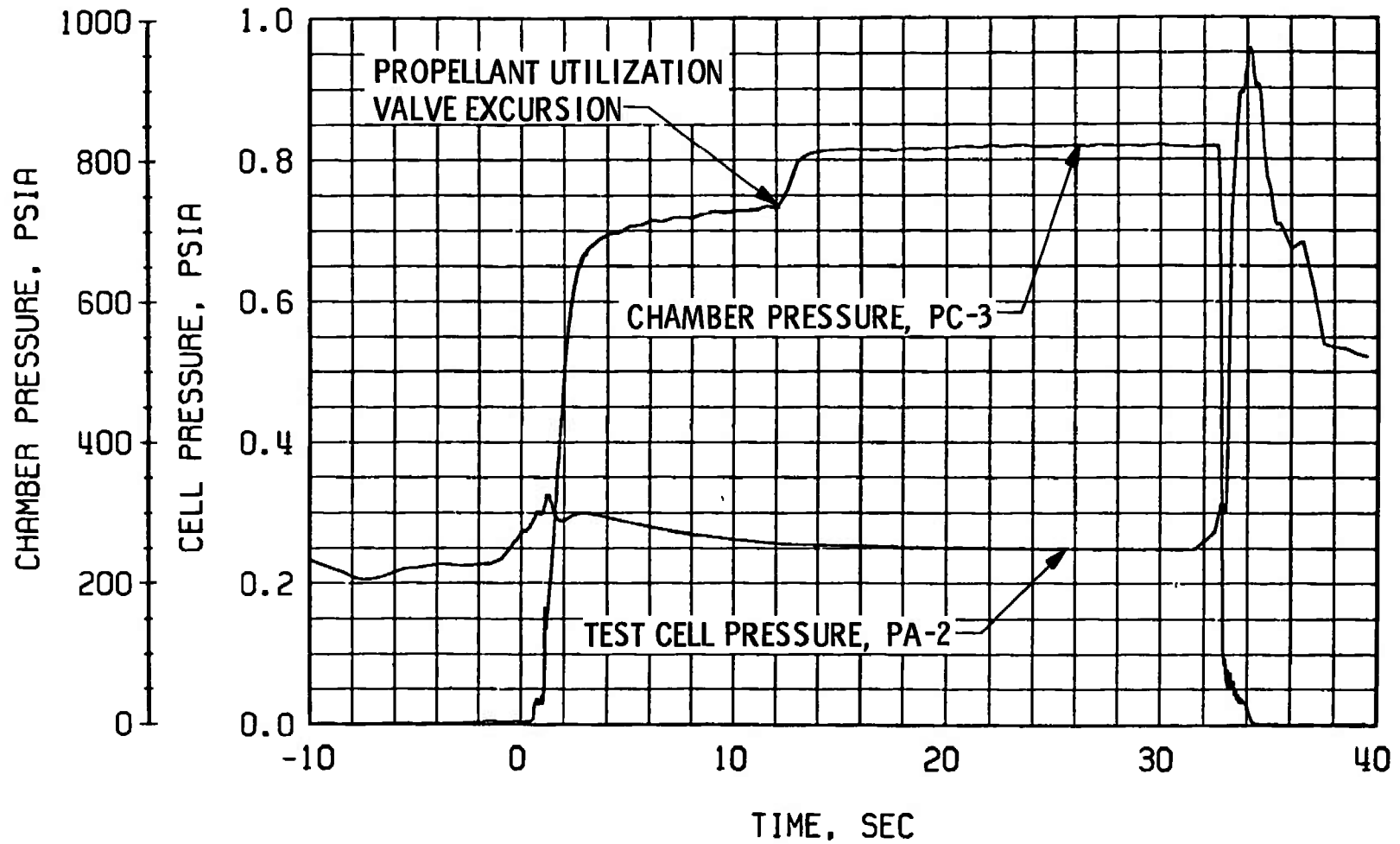
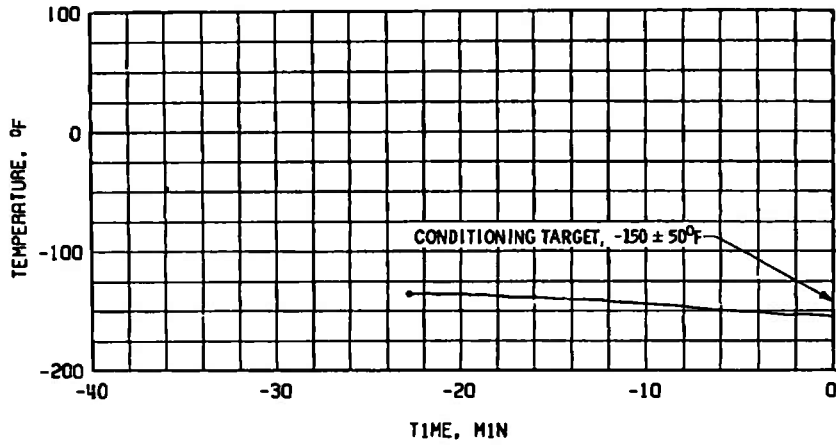
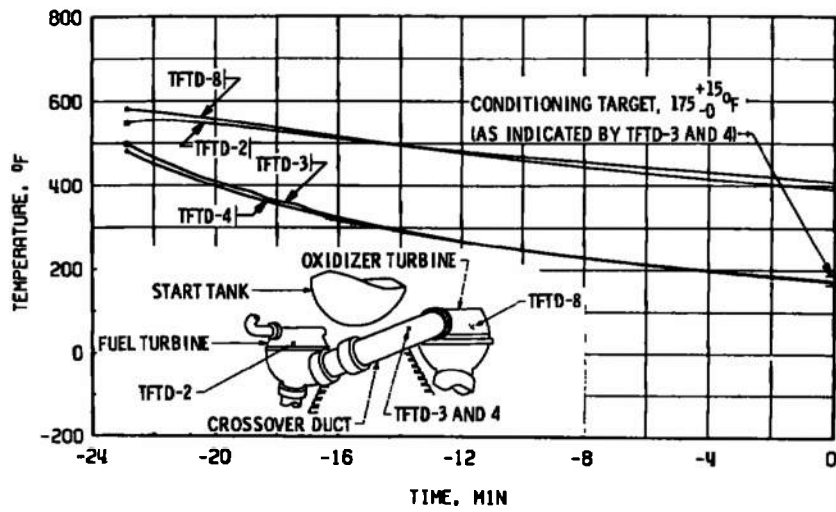

Fig. 12 Engine Ambient and Combustion Chamber Pressures, Firing 37A



a. Main Oxidizer Valve Second-Stage Actuator, TSOVC-1



b. Crossover Duct, TFTD

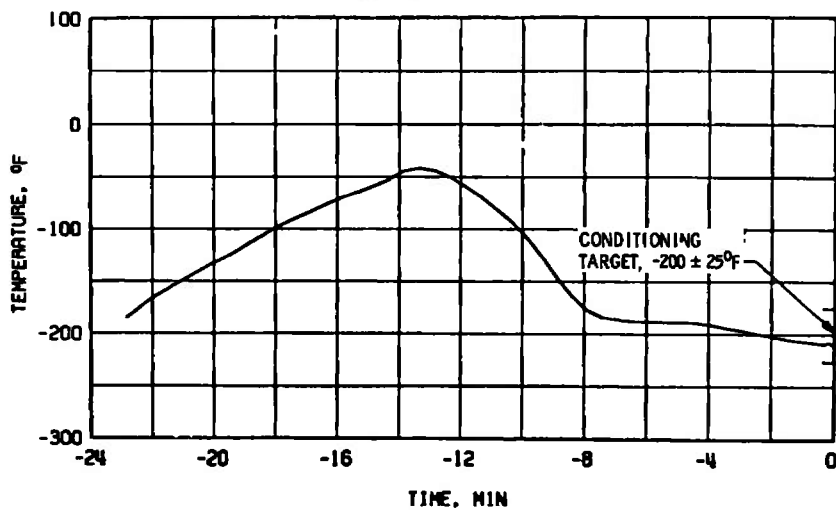

c. Thrust Chamber Throat, TTC-1P

Fig. 13 Thermal Conditioning History of Engine Components, Firing 37B

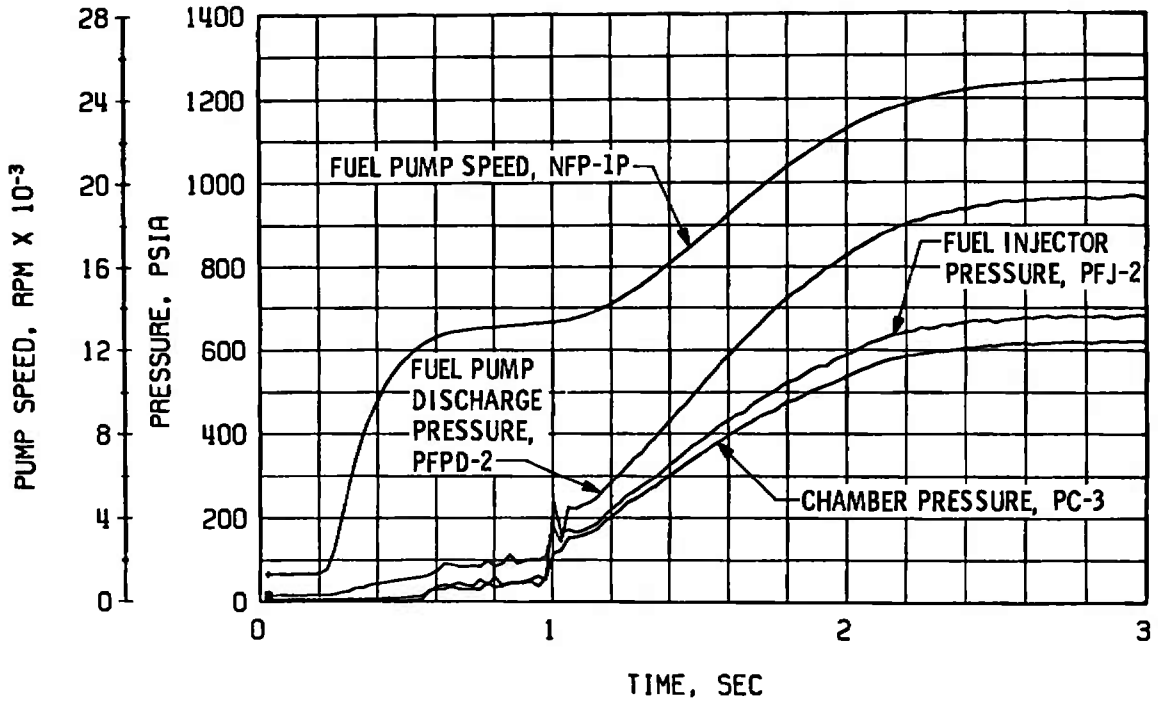

a. Thrust Chamber Fuel System, Start

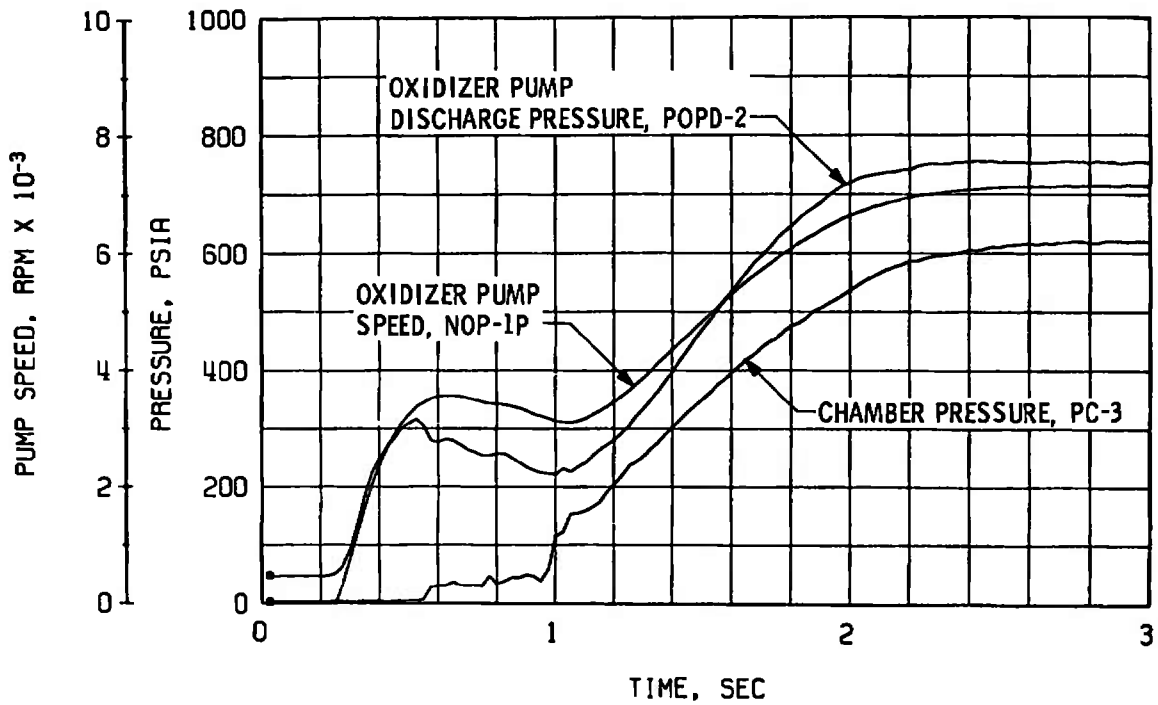

b. Thrust Chamber Oxidizer System, Start

Fig. 14 Engine Transient Operation, Firing 37B

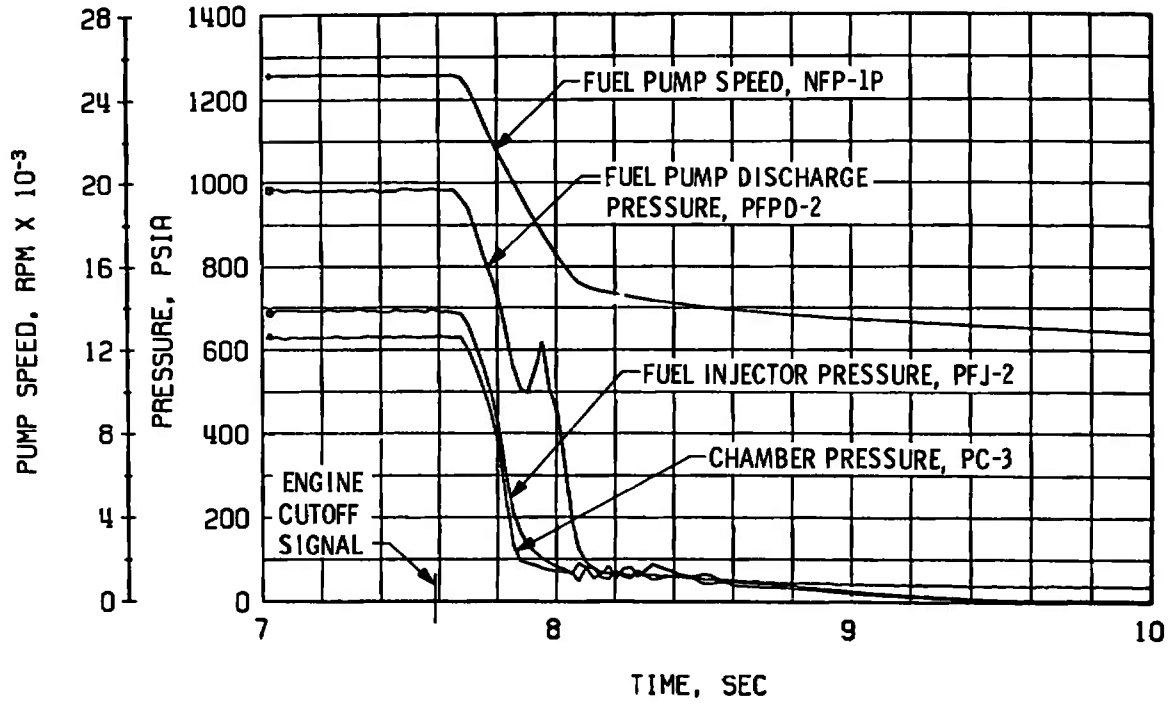

c. Thrust Chamber Fuel System, Shutdown

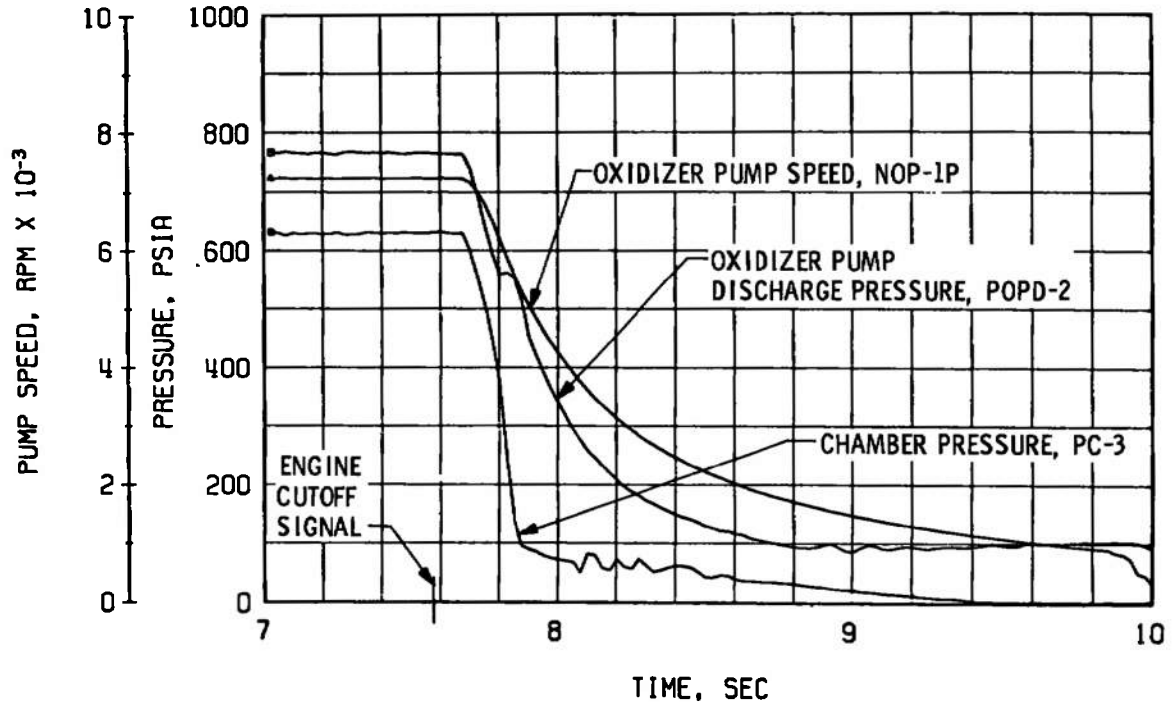

d. Thrust Chamber Oxidizer System, Shutdown

Fig. 14 Continued

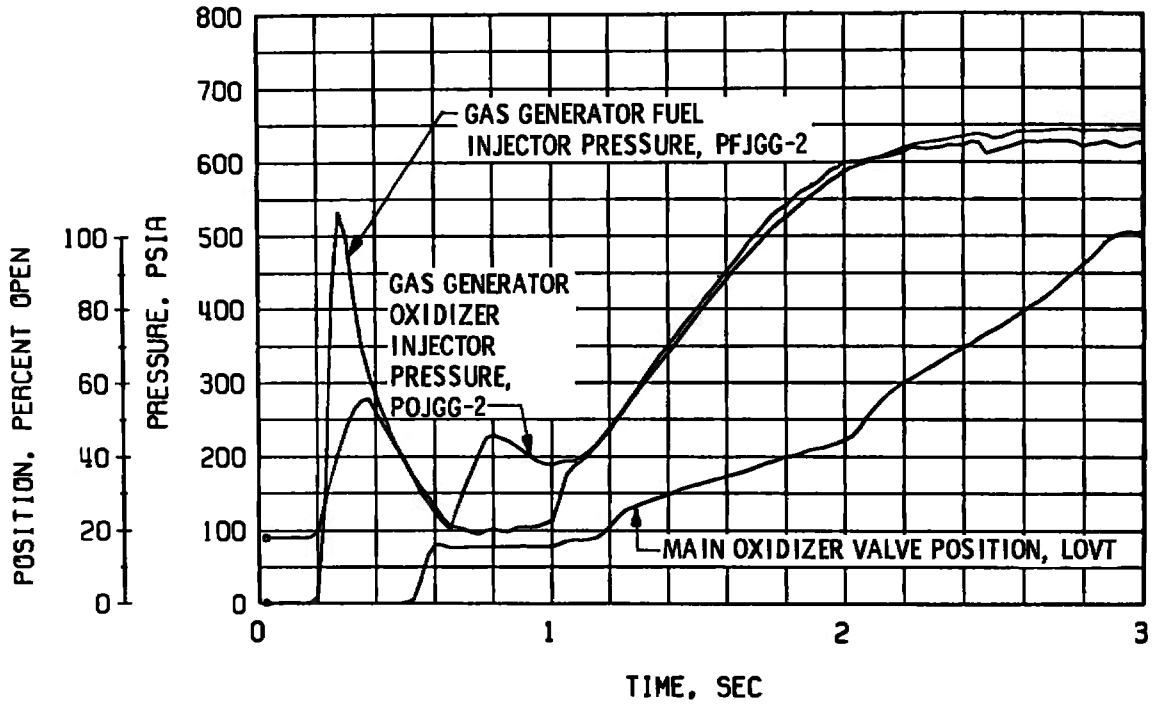

e. Gas Generator Injector Pressures and Main Oxidizer Valve Position, Start

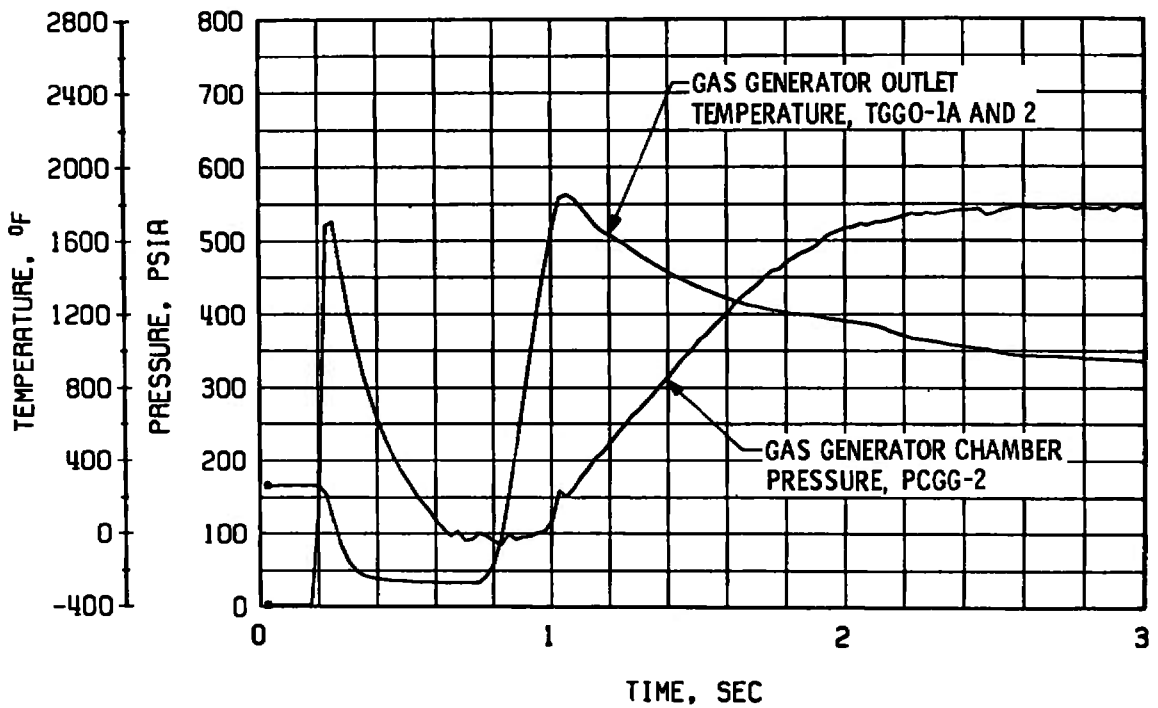

f. Gas Generator Chamber Pressure and Temperature, Start

Fig. 14 Continued

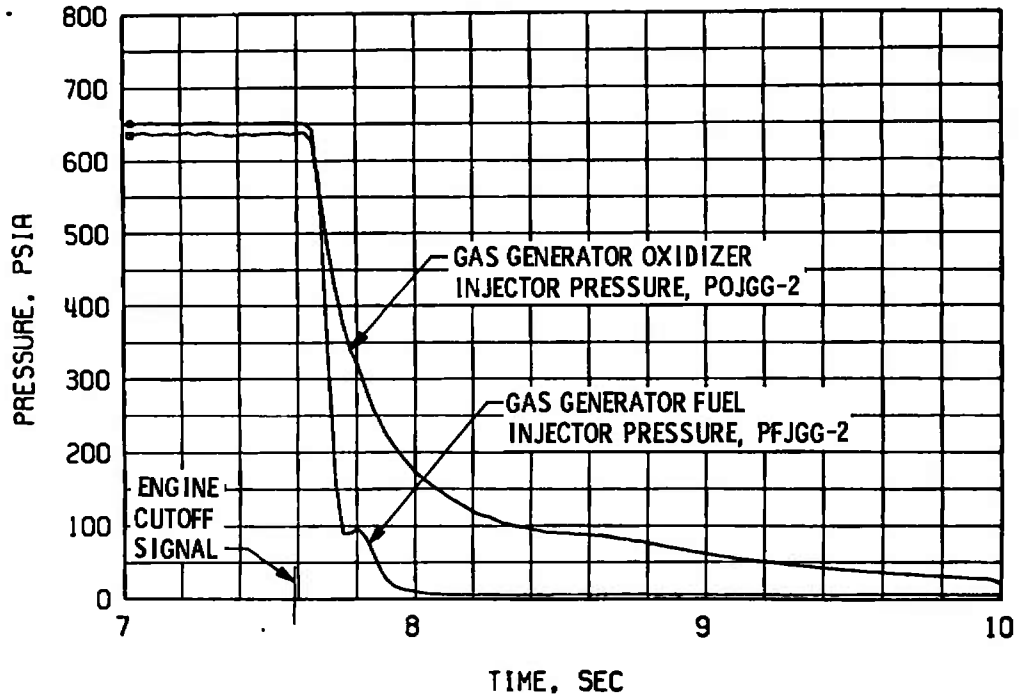

g. Gas Generator Injector Pressures, Shutdown

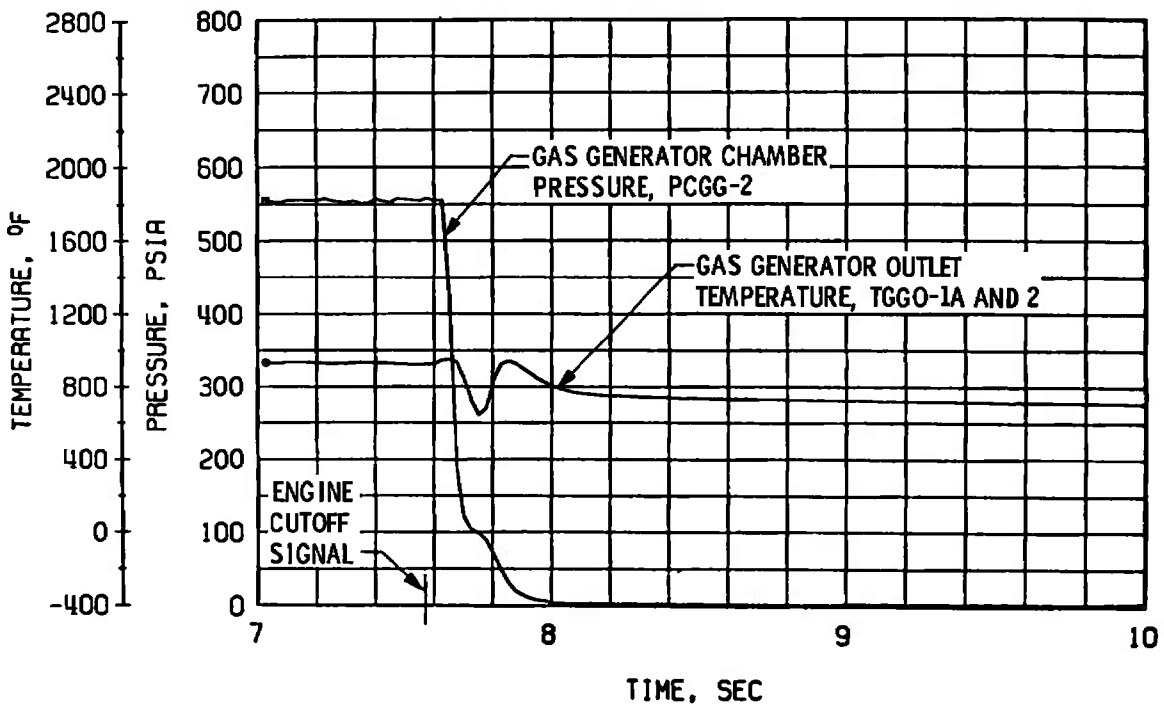

h. Gas Generator Chamber Pressure and Temperature, Shutdown

Fig. 14 Concluded

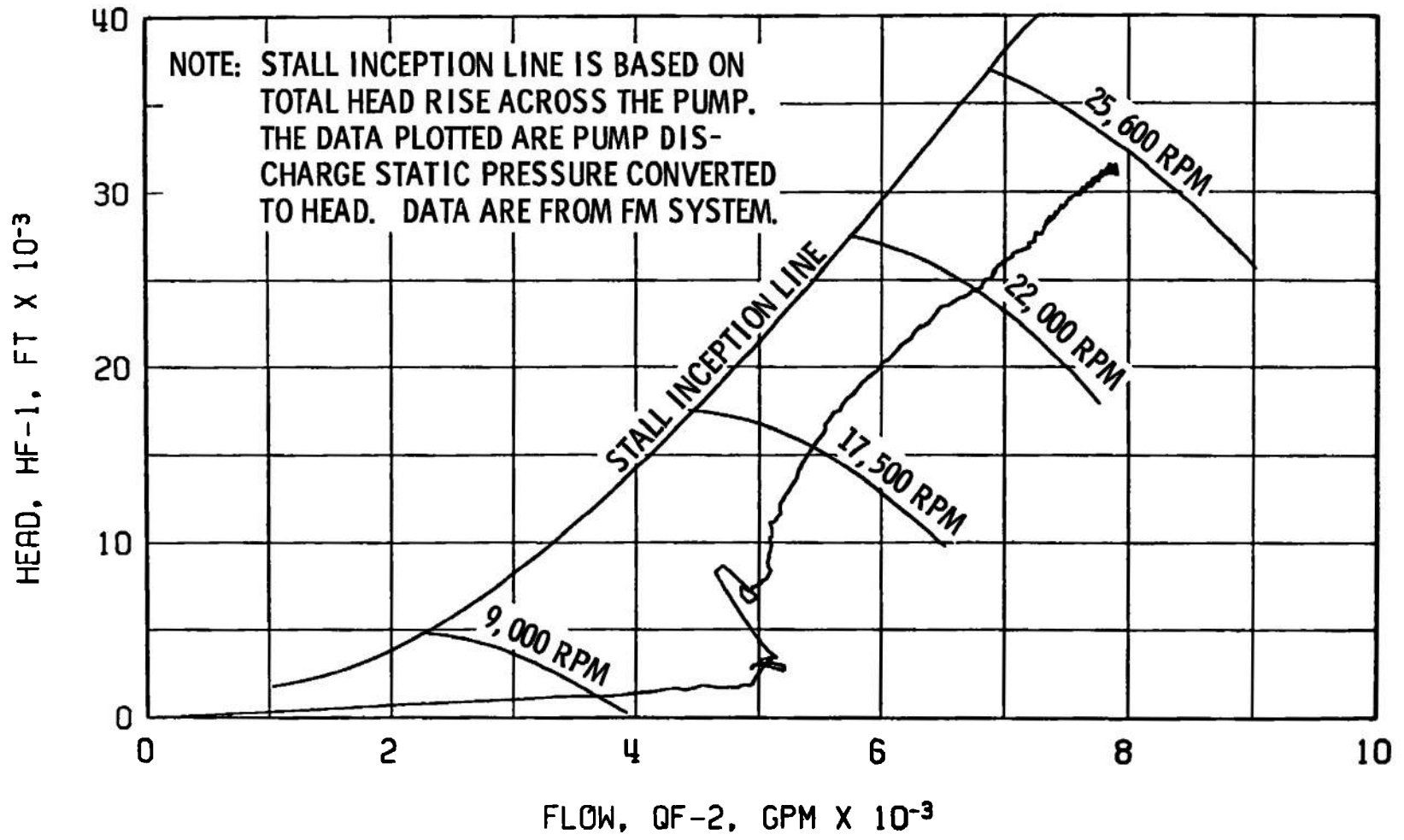

Fig. 15 Fuel Pump Start Transient Performance, Firing 37B

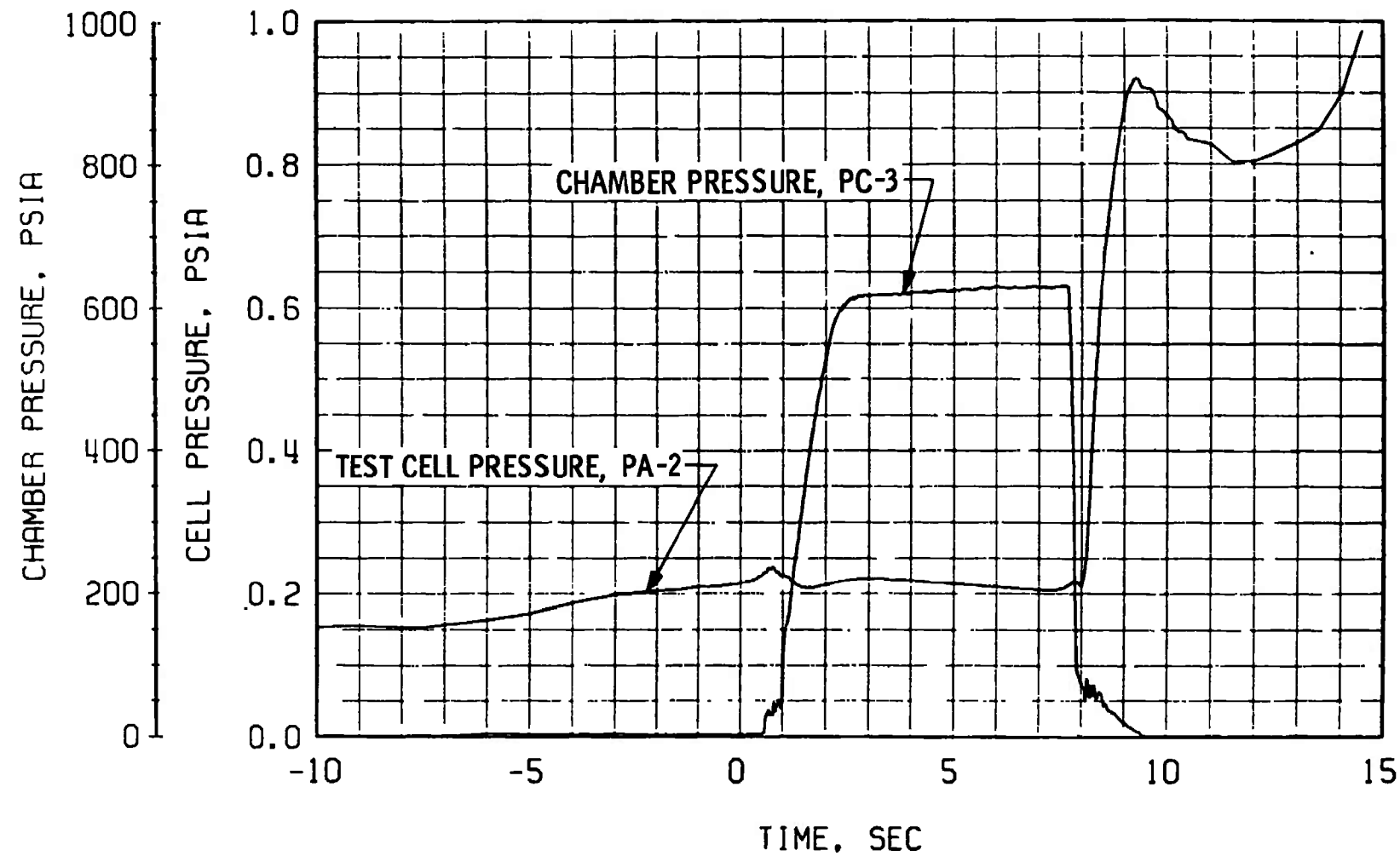
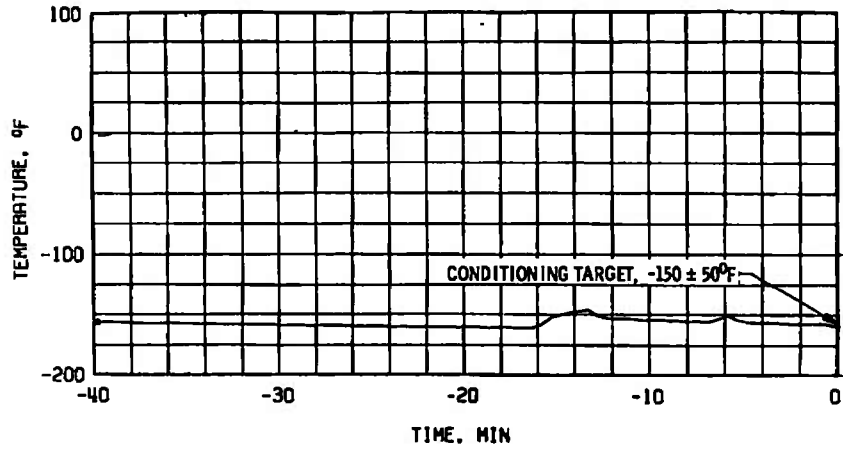
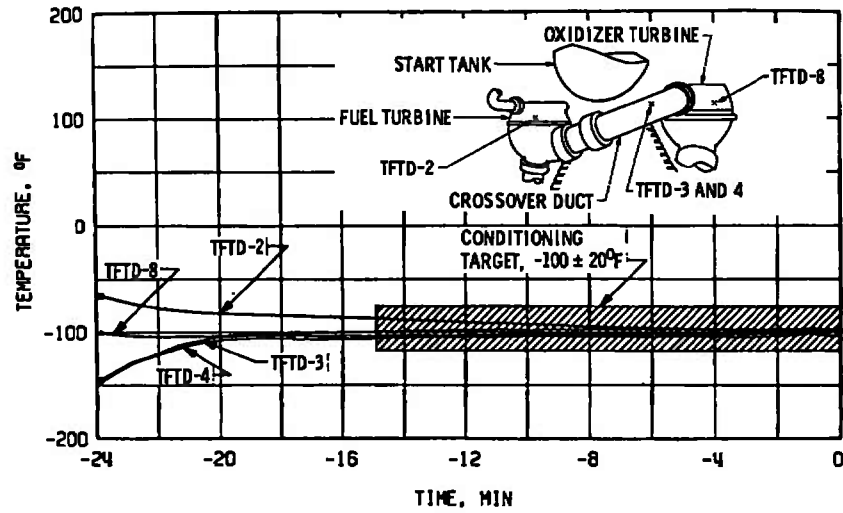

Fig. 16 Engine Ambient and Combustion Chamber Pressures, Firing 37B



a. Main Oxidizer Valve Second-Stage Actuator, TSOVC-1



b. Crossover Duct, TFTD

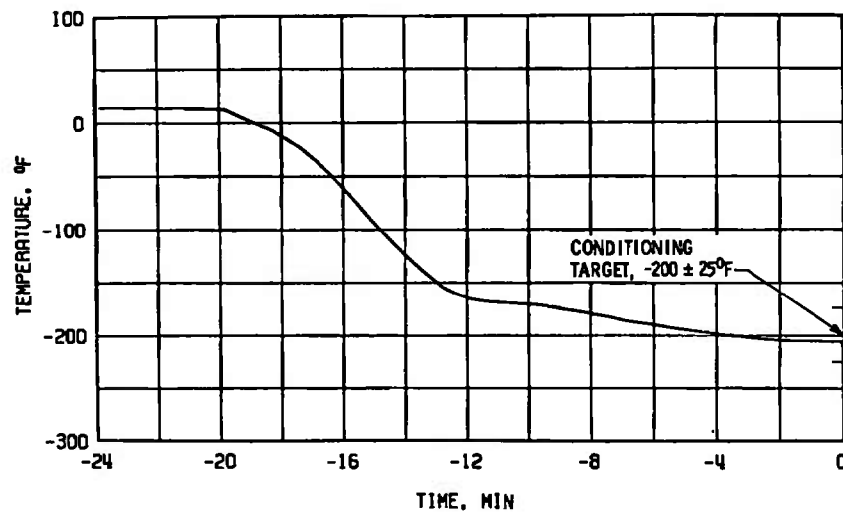

c. Thrust Chamber Throat, TTC-1P

Fig. 17 Thermal Conditioning History of Engine Components, Firing 37C

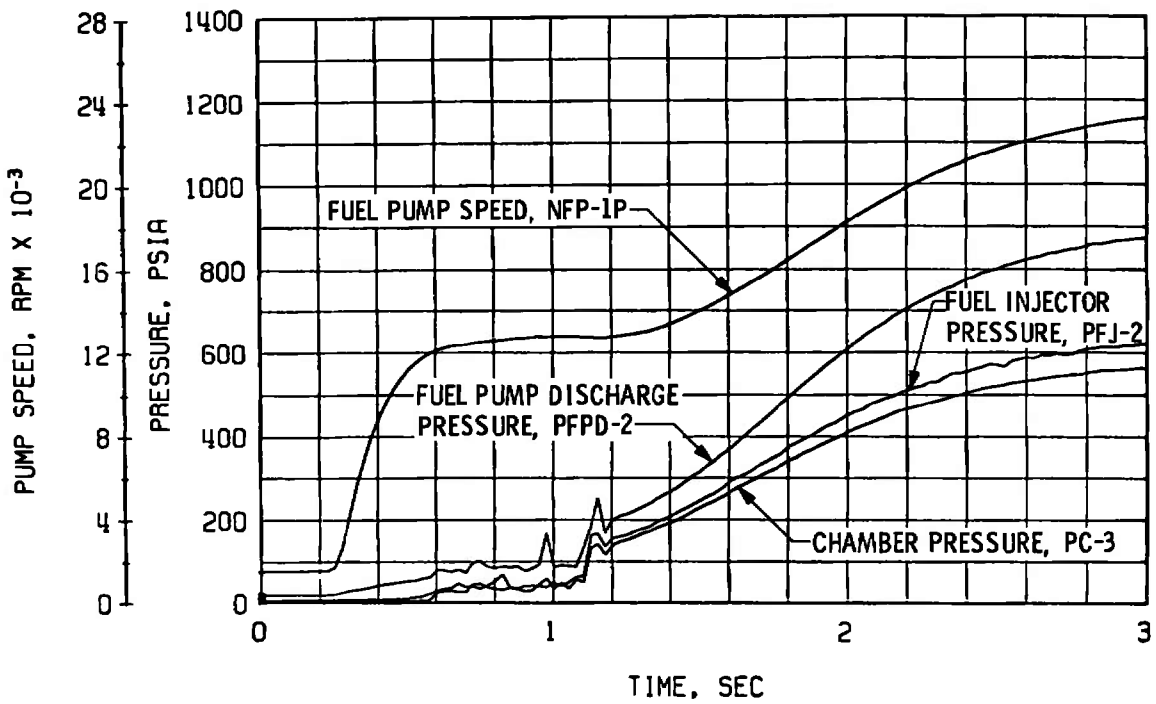

a. Thrust Chamber Fuel System, Start

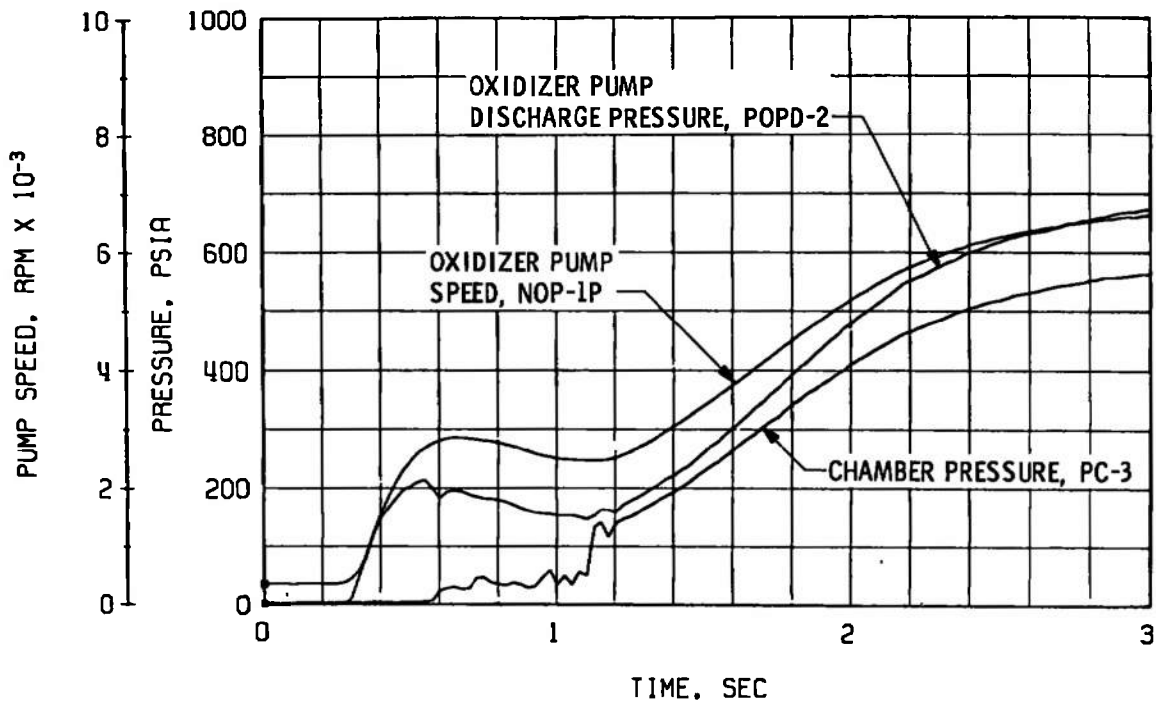

b. Thrust Chamber Oxidizer System, Start

Fig. 18 Engine Transient Operation, Firing 37C

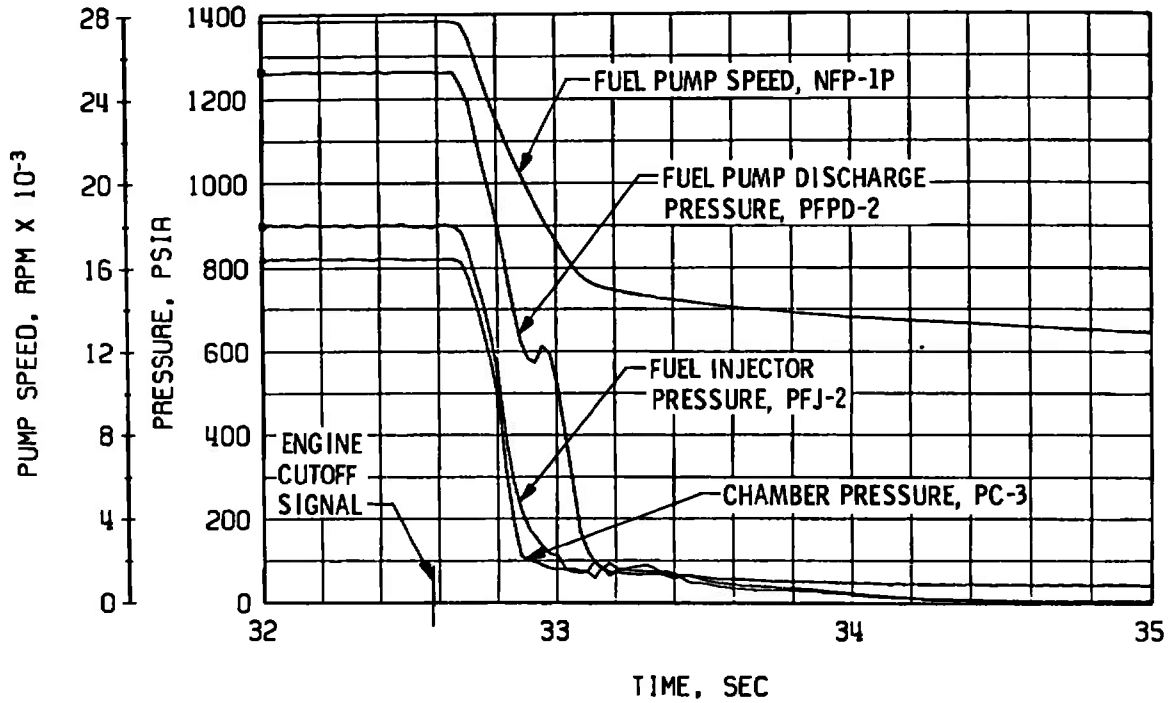

c. Thrust Chamber Fuel System, Shutdown

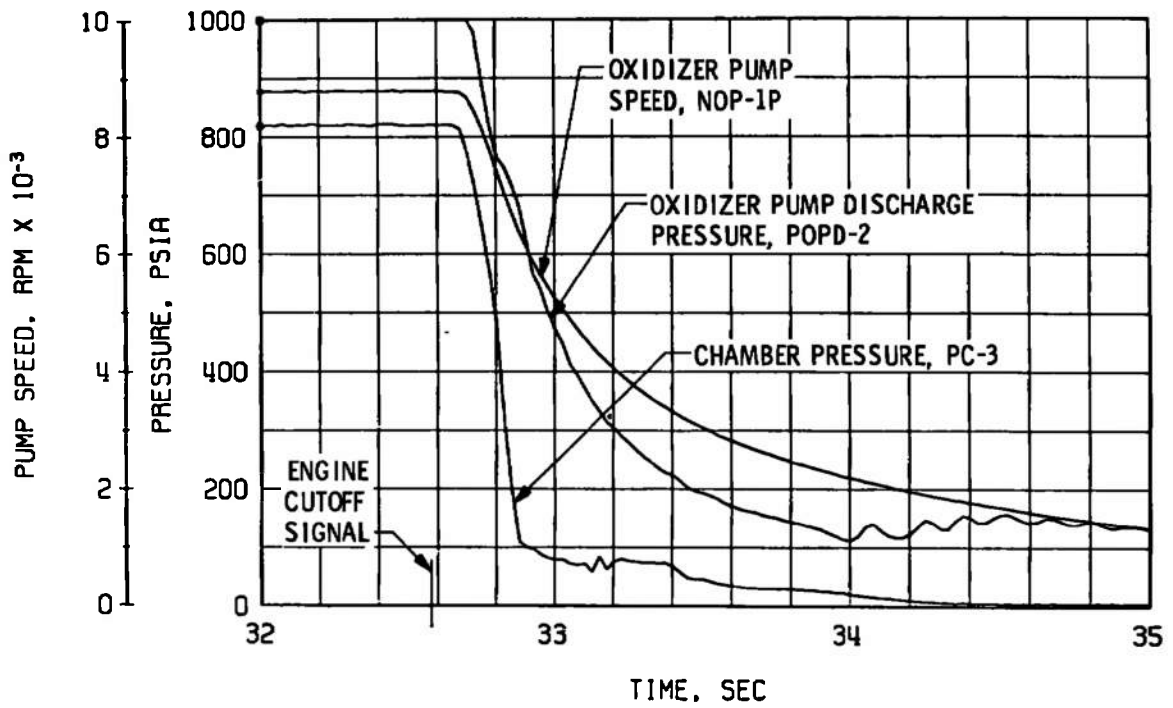

d. Thrust Chamber Oxidizer System, Shutdown

Fig. 18 Continued

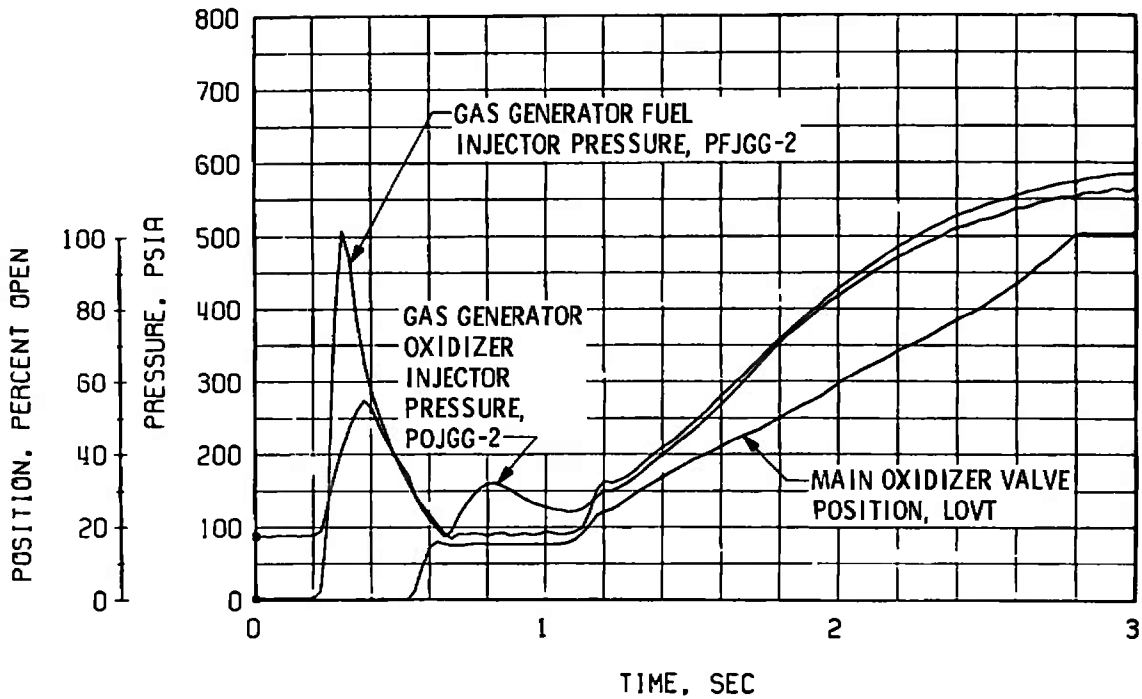

e. Gas Generator Injector Pressures and Main Oxidizer Valve Position, Start

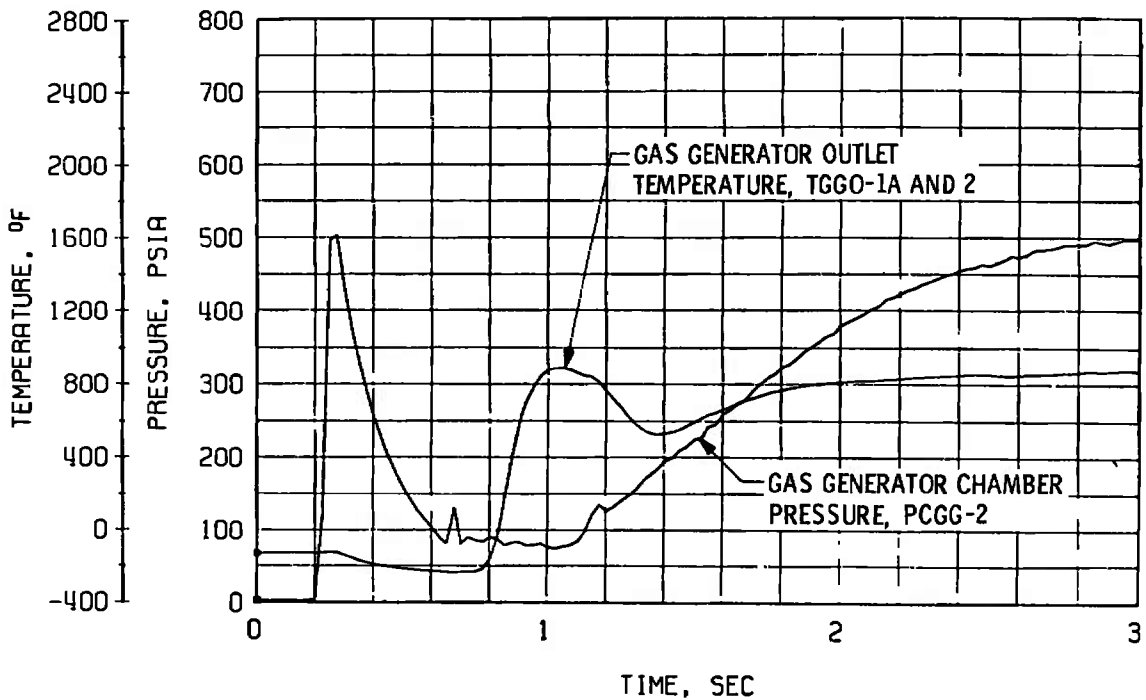

f. Gas Generator Chamber Pressure and Temperature, Start

Fig. 18 Continued

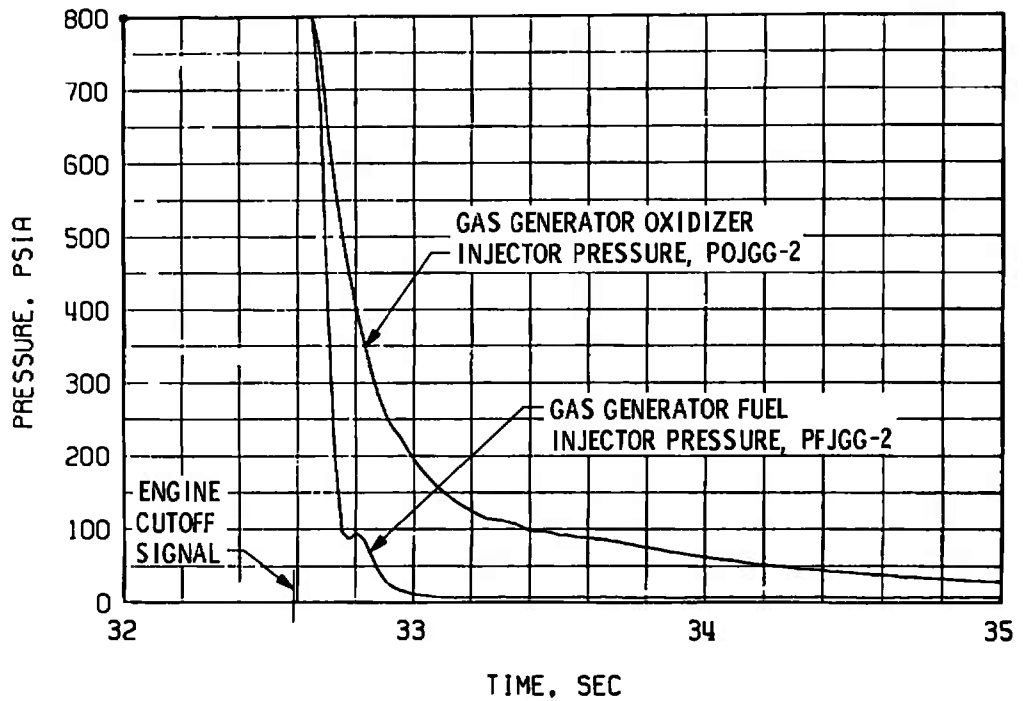

g. Gas Generator Injector Pressures, Shutdown

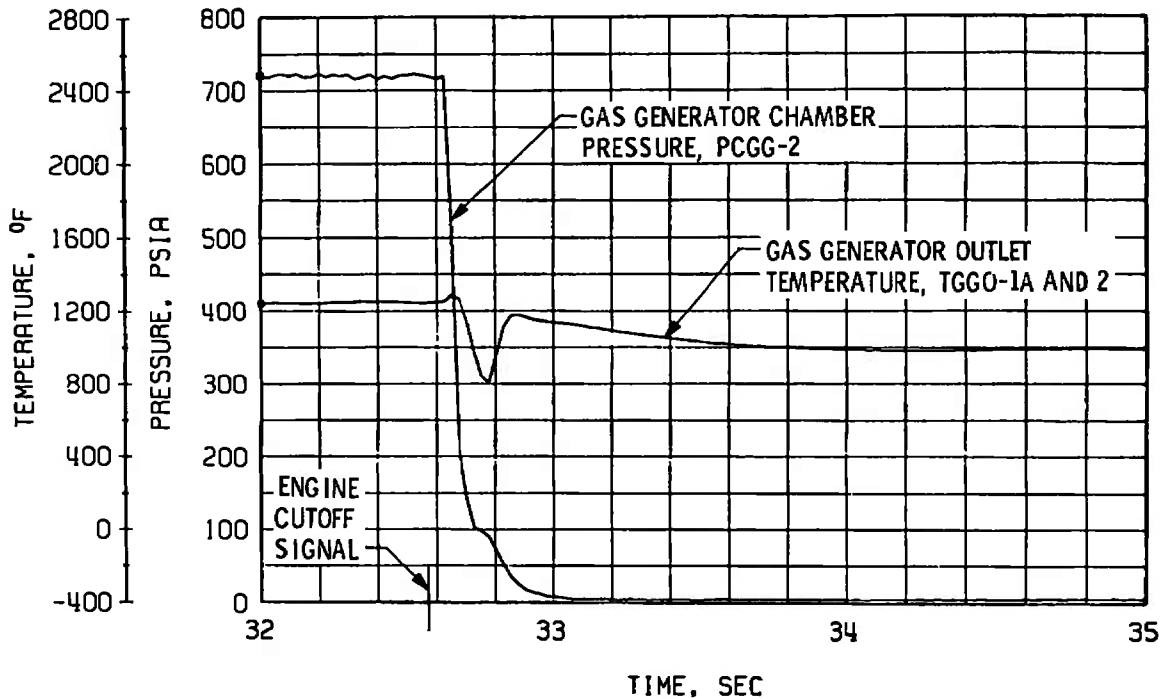

h. Gas Generator Chamber Pressure and Temperature, Shutdown

Fig. 18 Concluded

50

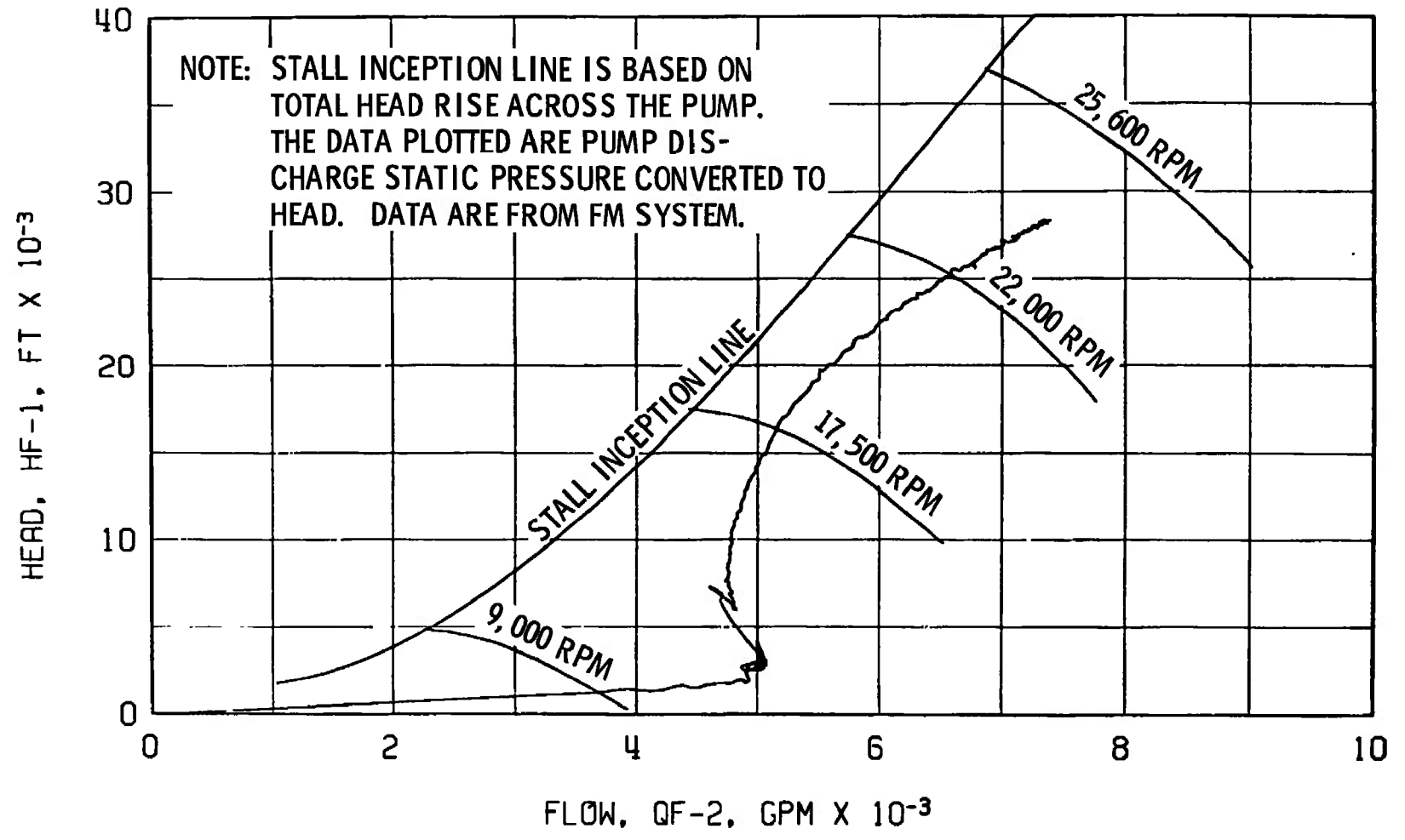

Fig. 19 Fuel Pump Start Transient Performance, Firing 37C

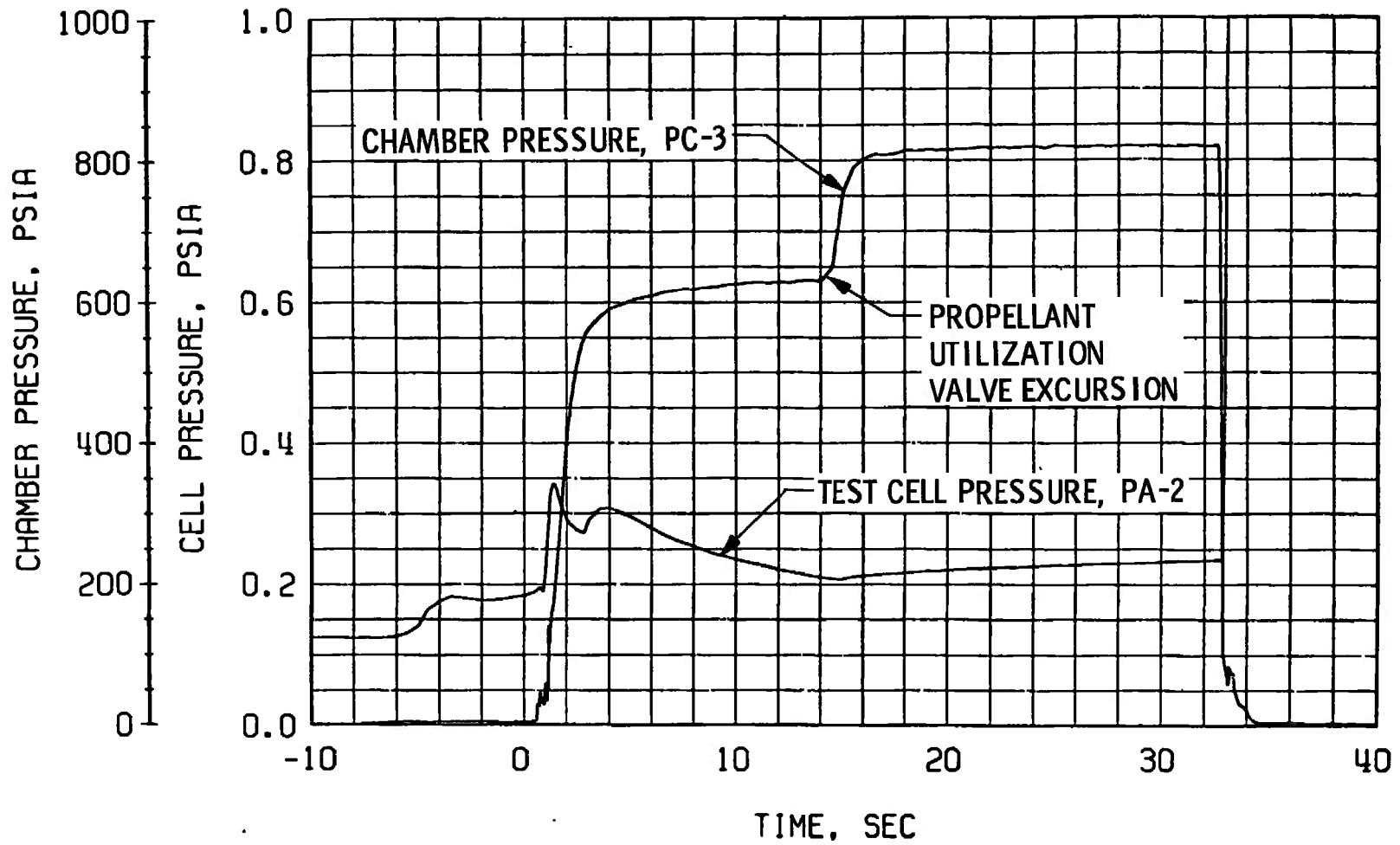
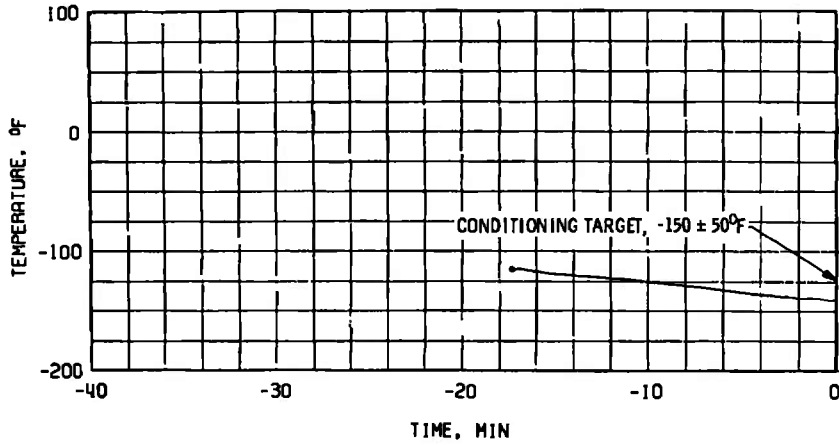
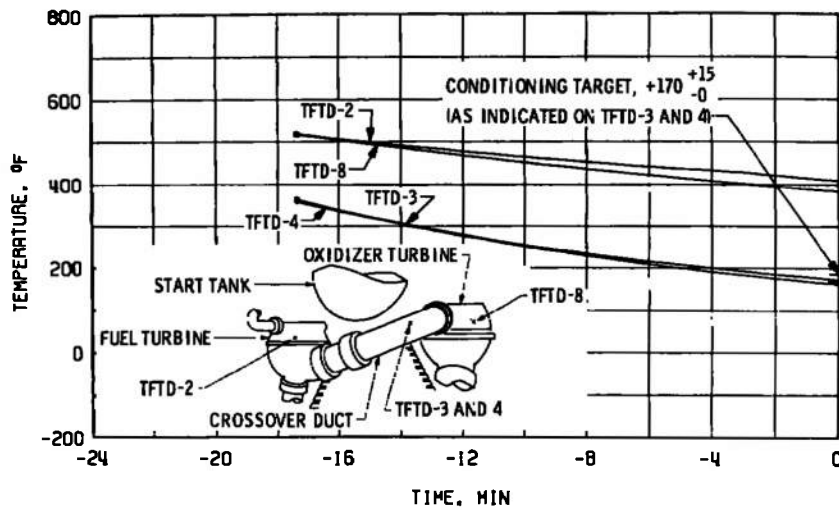

Fig. 20 Engine Ambient and Combustion Chamber Pressures, Firing 37C



a. Main Oxidizer Valve Second-Stage Actuator, TSOVC-1



b. Crossover Duct, TTFD

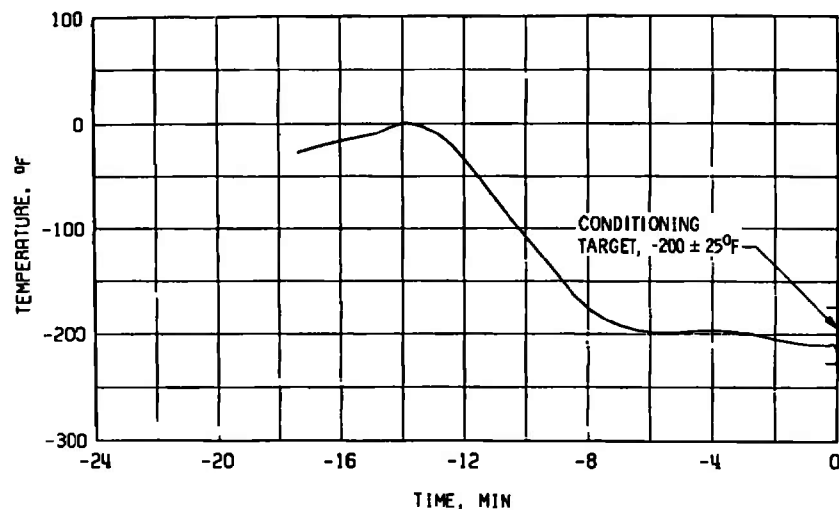

c. Thrust Chamber Throat, TTC-1P

Fig. 21 Thermal Conditioning History of Engine Components, Firing 37D

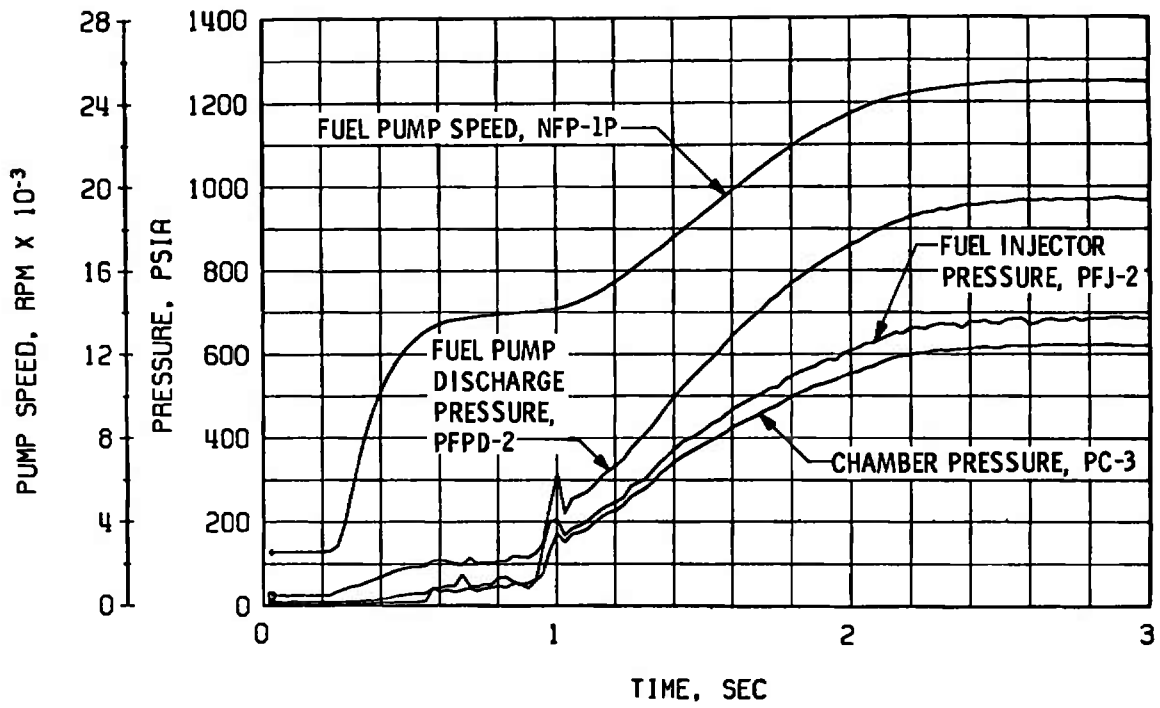

a. Thrust Chamber Fuel System, Start

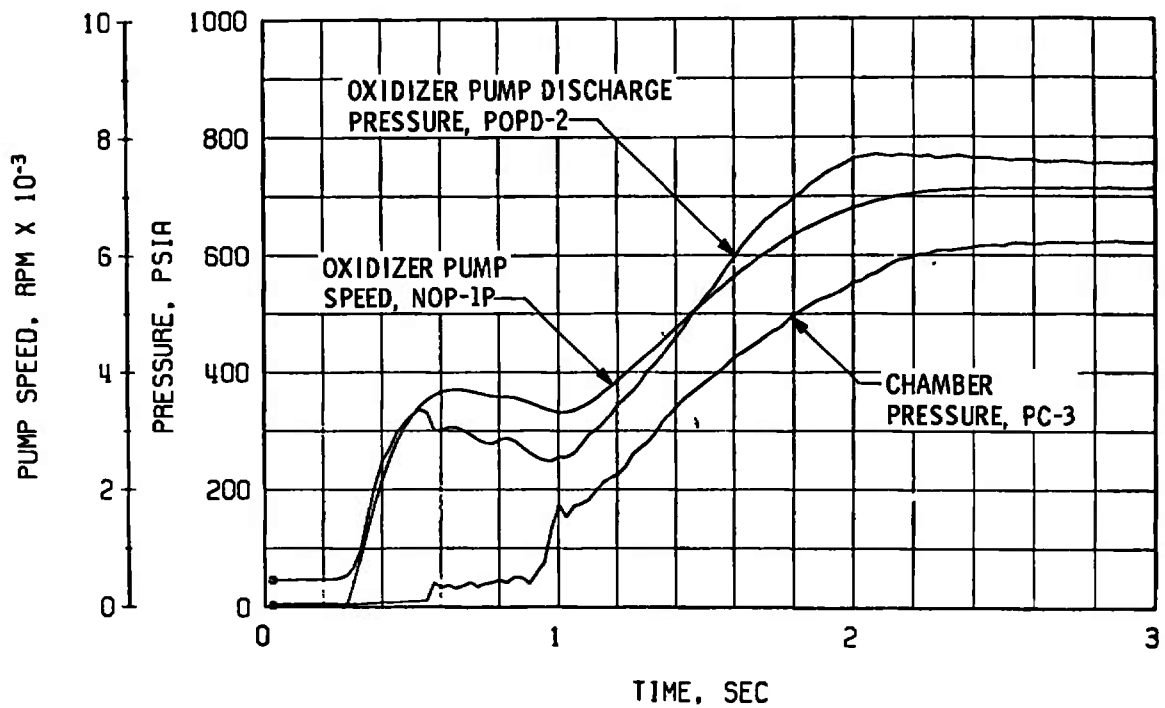

b. Thrust Chamber Oxidizer System, Start

Fig. 22 Engine Transient Operation, Firing 37D

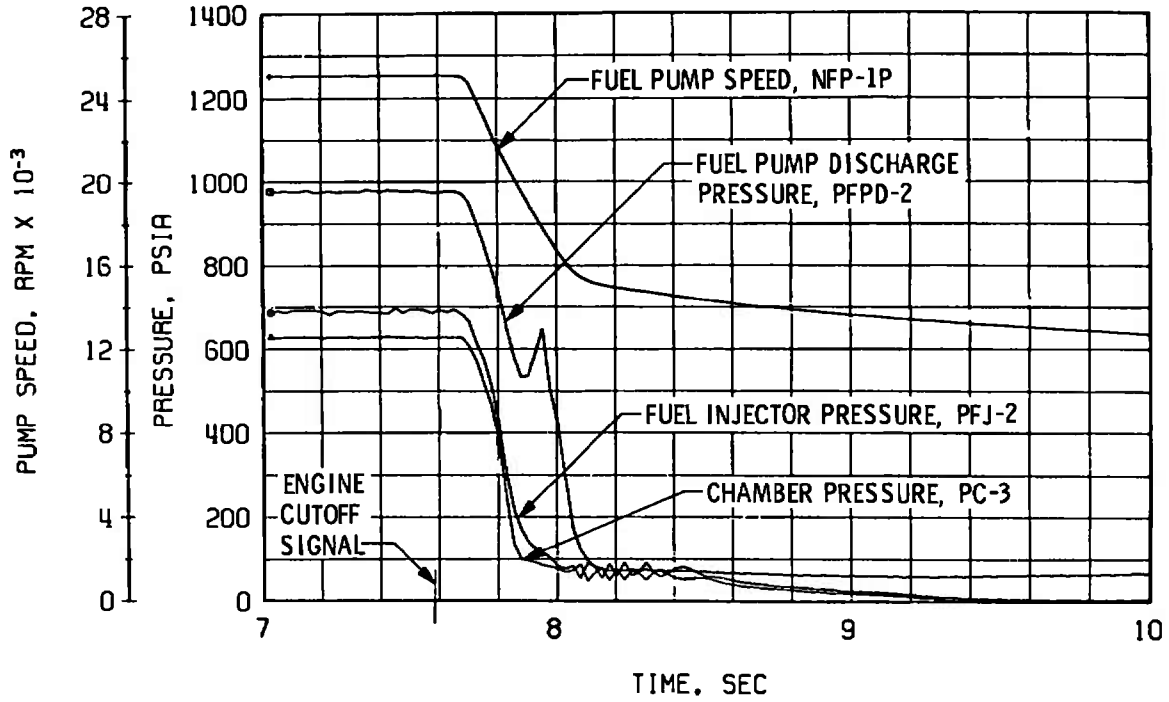

c. Thrust Chamber Fuel System, Shutdown

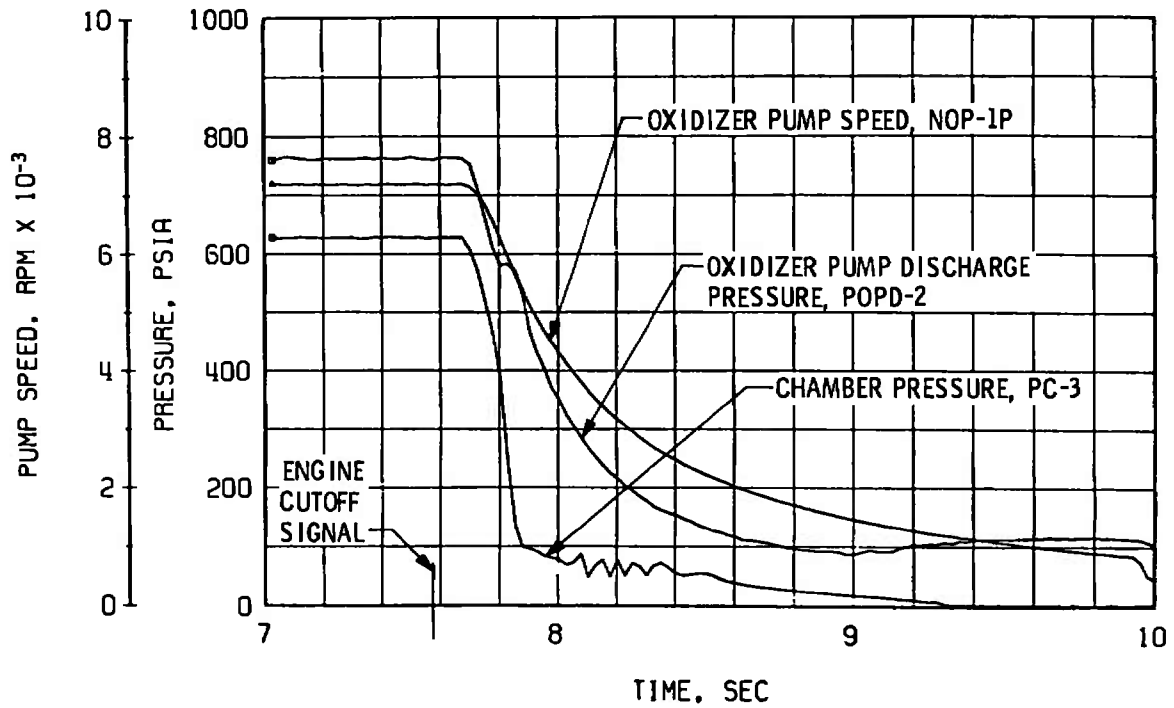

d. Thrust Chamber Oxidizer System, Shutdown

Fig. 22 Continued

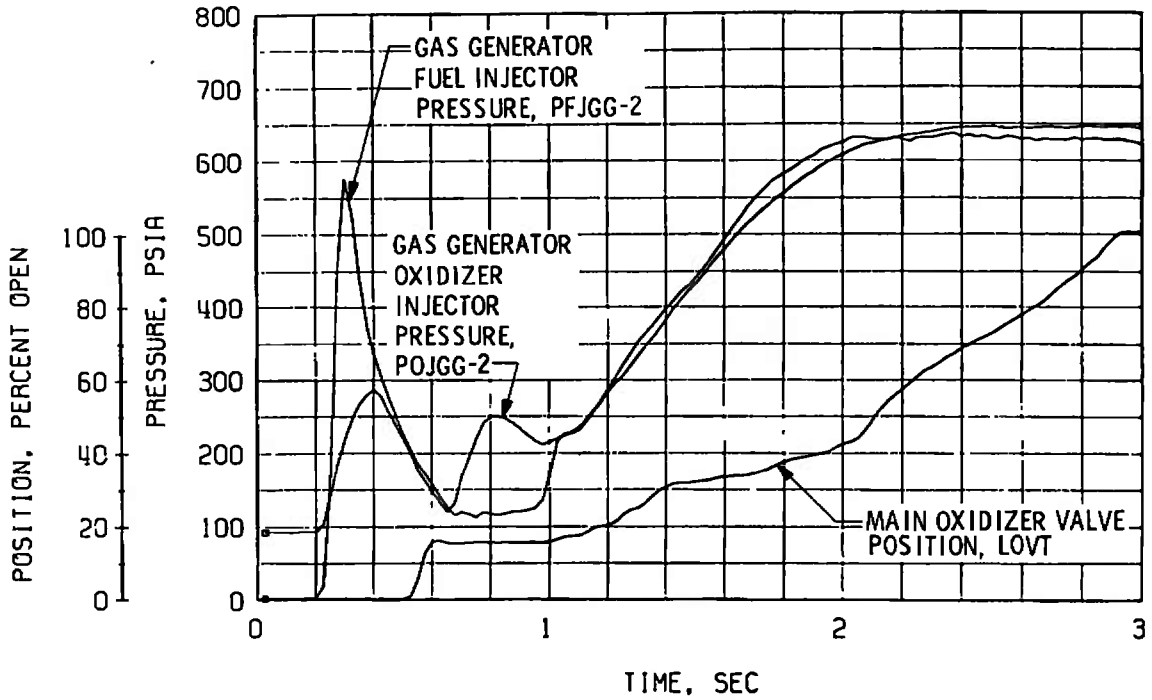

e. Gas Generator Injector Pressures and Main Oxidizer Valve Position, Start

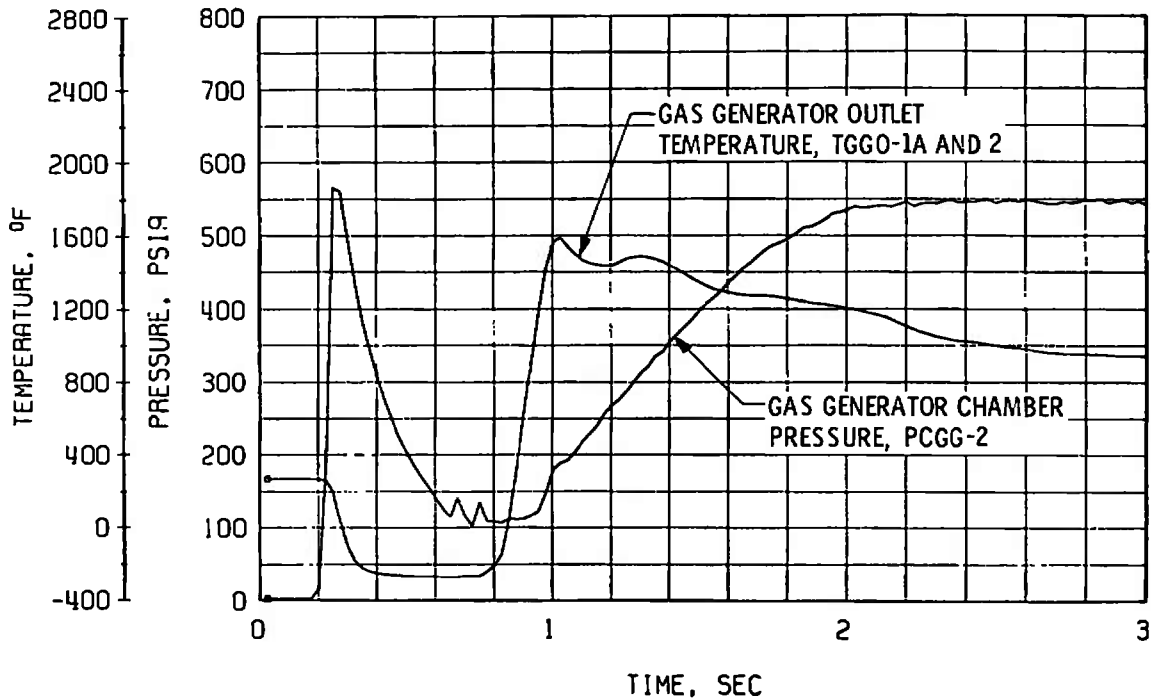

f. Gas Generator Chamber Pressure and Temperature, Start

Fig. 22 Continued

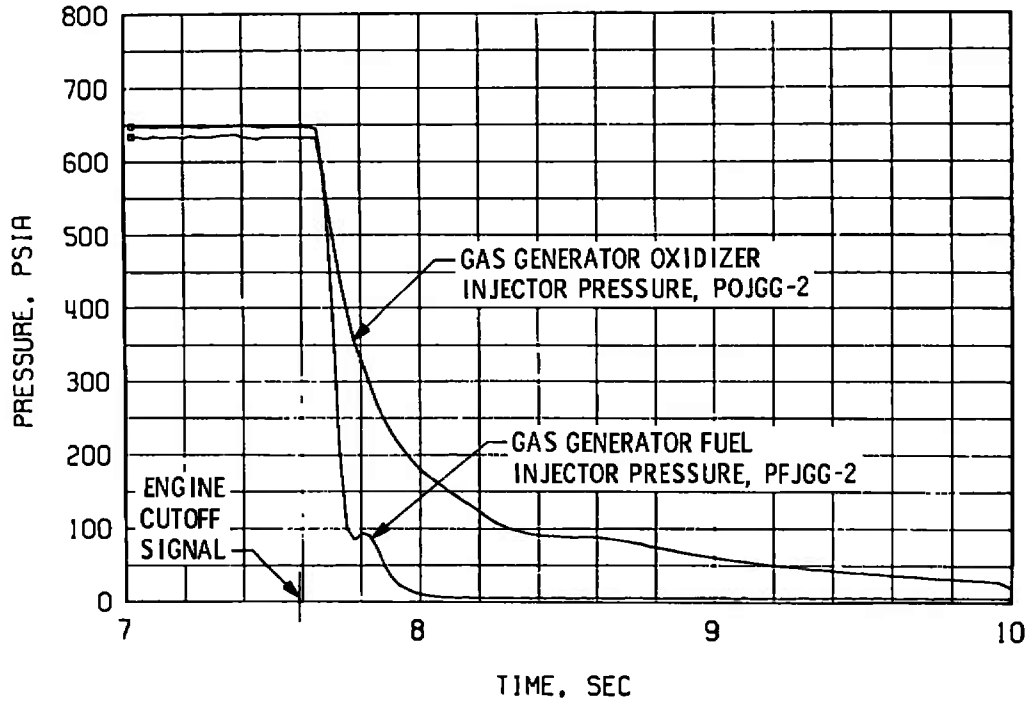

g. Gas Generator Injector Pressures, Shutdown

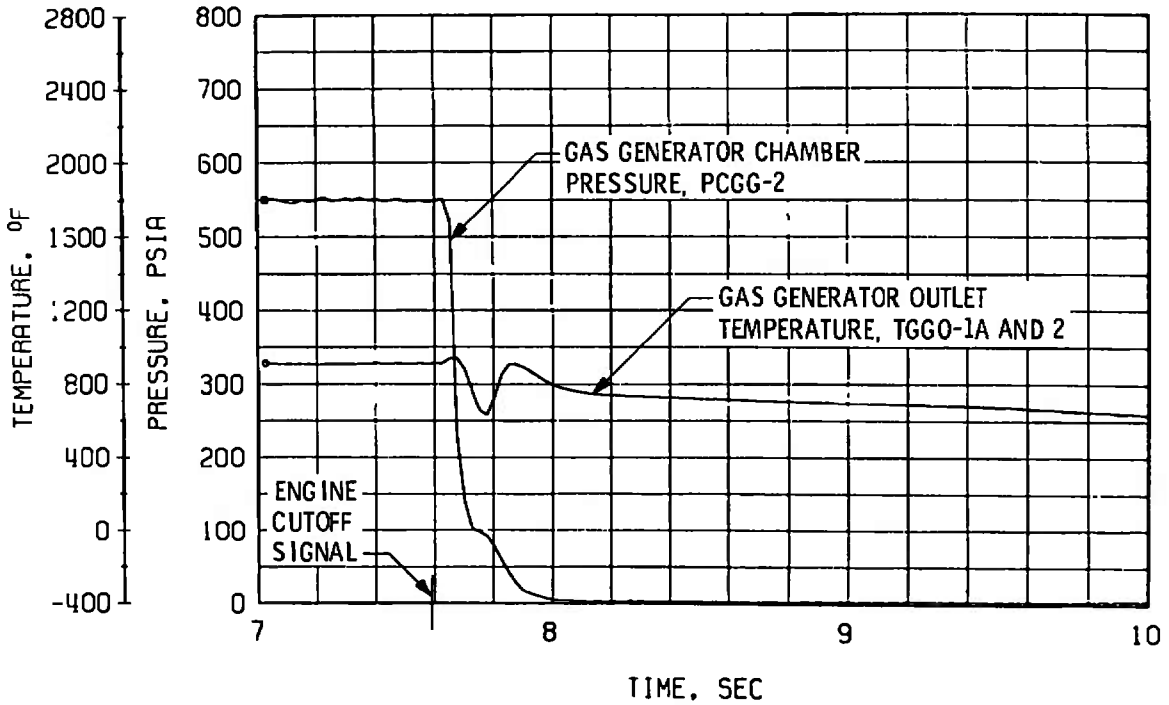

h. Gas Generator Chamber Pressure and Temperature, Shutdown

Fig. 22 Concluded

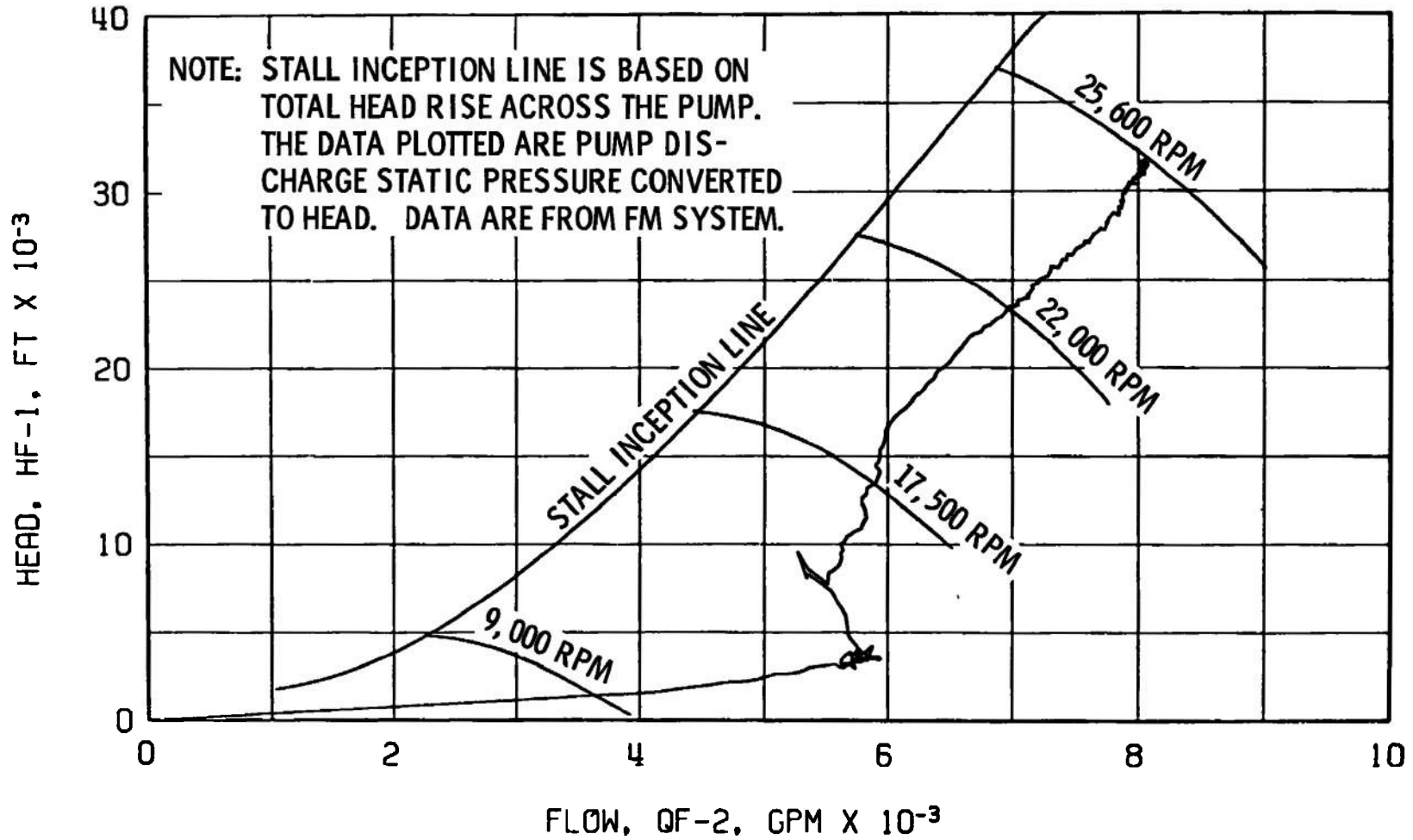

Fig. 23 Fuel Pump Start Transient Performance, Firing 37D

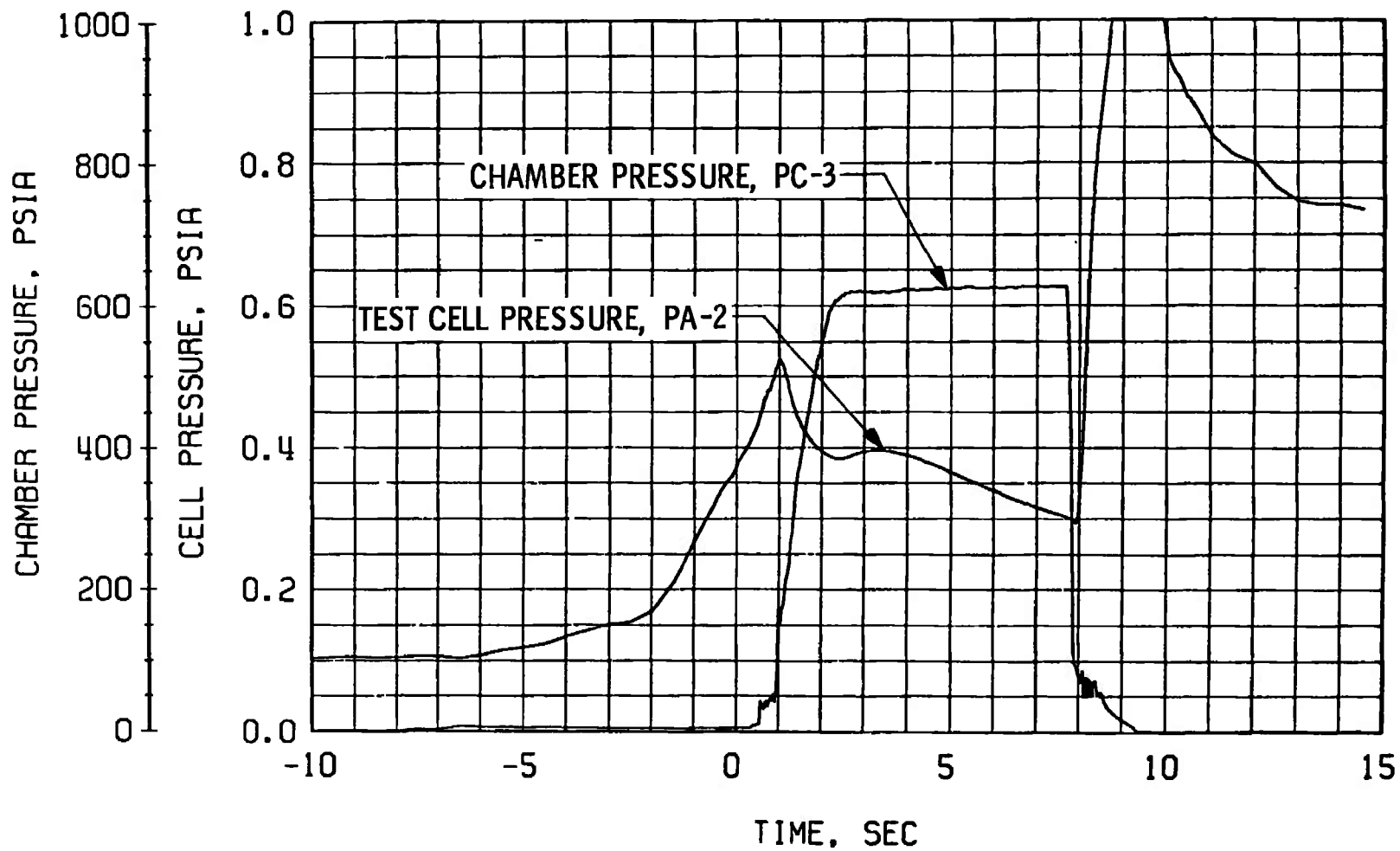
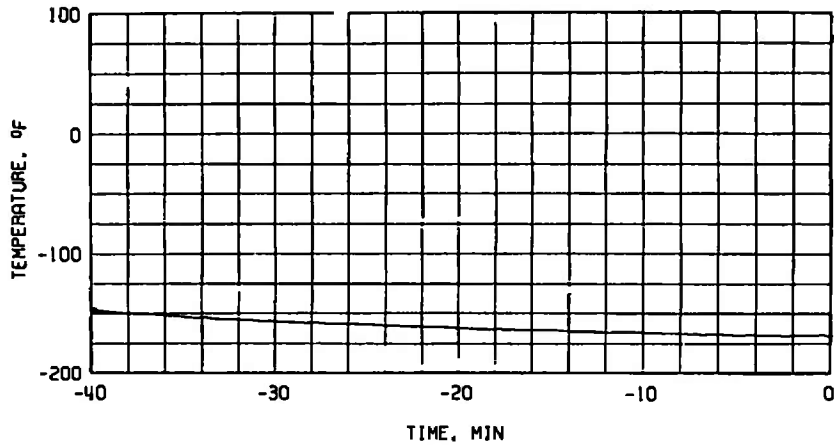
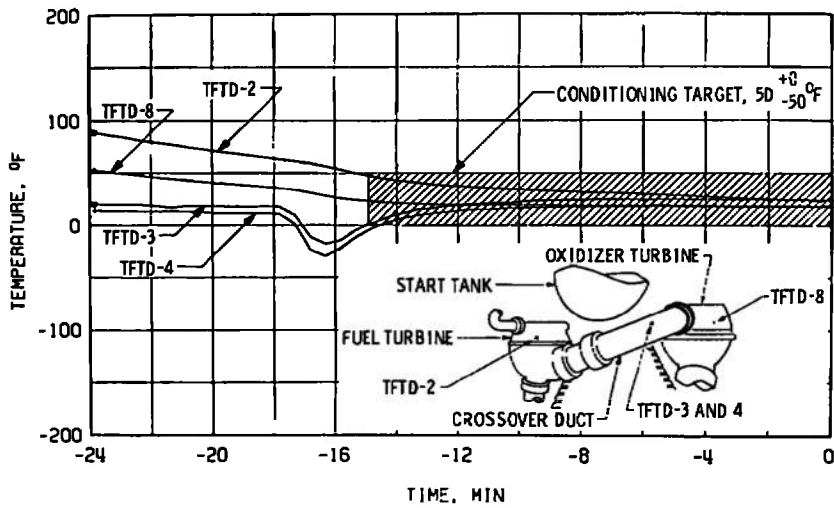

Fig. 24 Engine Ambient and Combustion Chamber Pressures, Firing 37D



a. Main Oxidizer Valve Second-Stage Actuator, TSOVC-1



b. Crossover Duct, TFTD

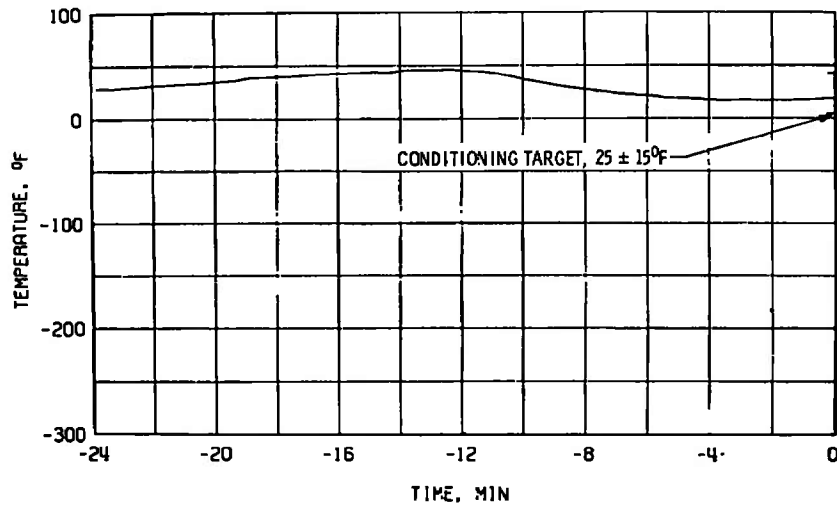

c. Thrust Chamber Throat, TTC-1P

Fig. 25 Thermol Conditioning History of Engine Components, Firing 37E

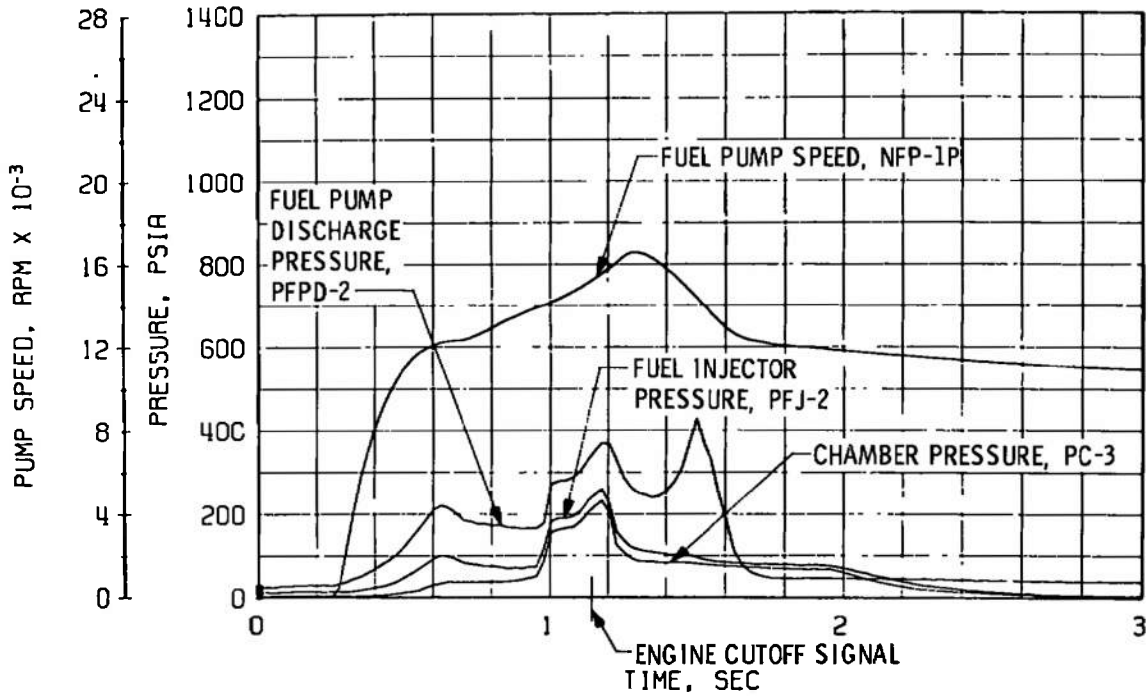

a. Thrust Chamber Fuel System, Start

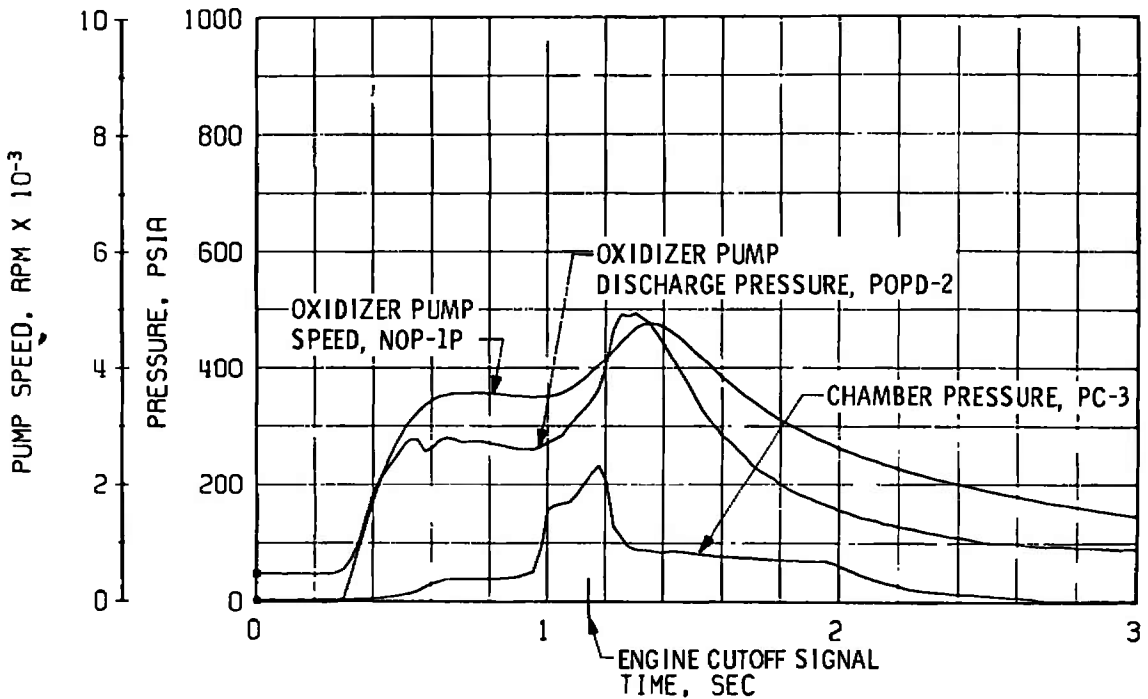

b. Thrust Chamber Oxidizer System, Start

Fig. 26 Engine Transient Operation, Firing 37E

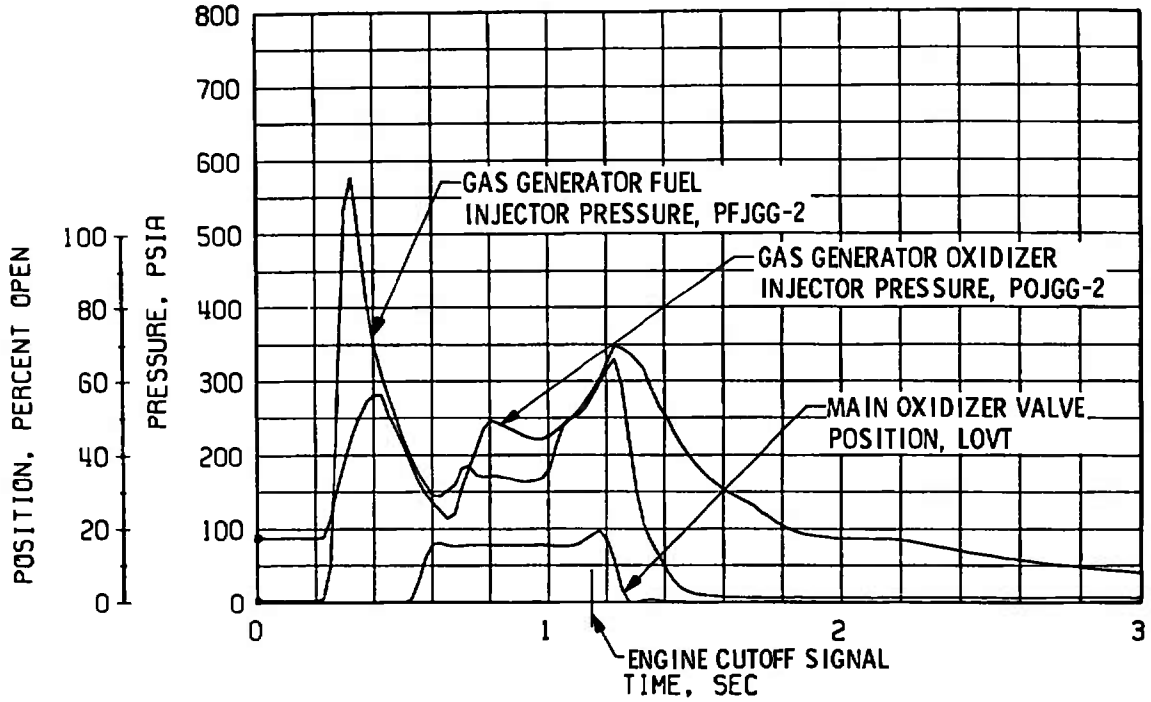

c. Gas Generator Injector Pressures and Main Oxidizer Valve Position, Start

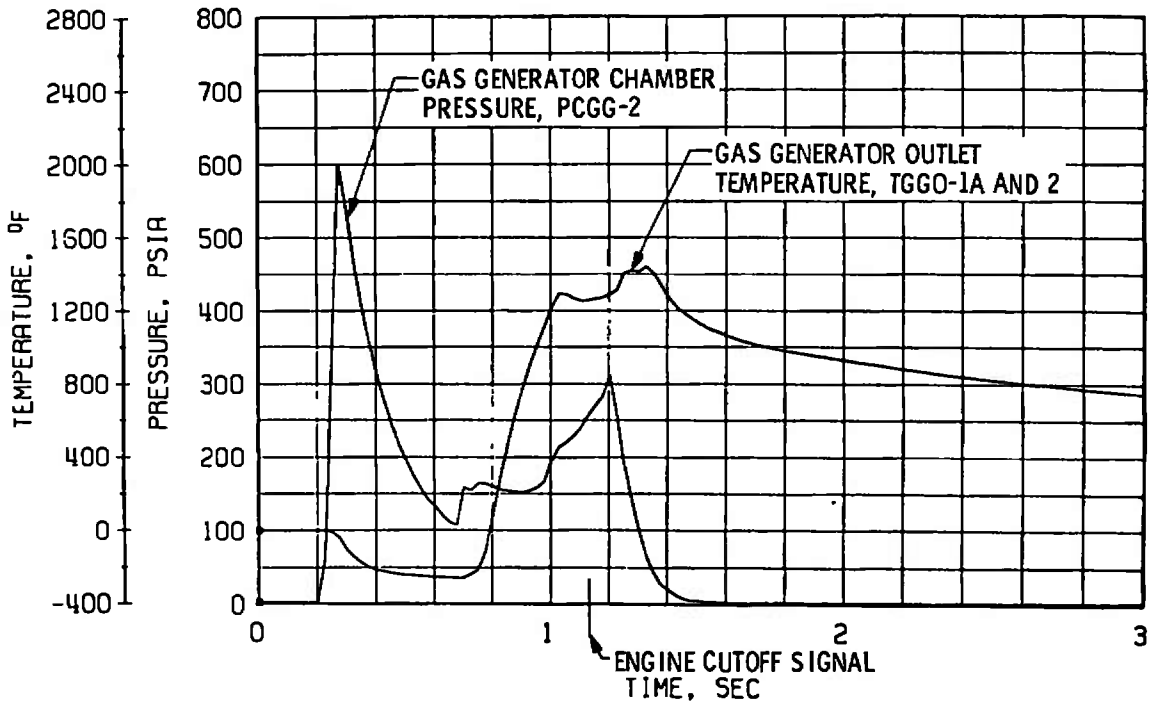

d. Gas Generator Chamber Pressure and Temperature, Start

Fig. 26 Concluded

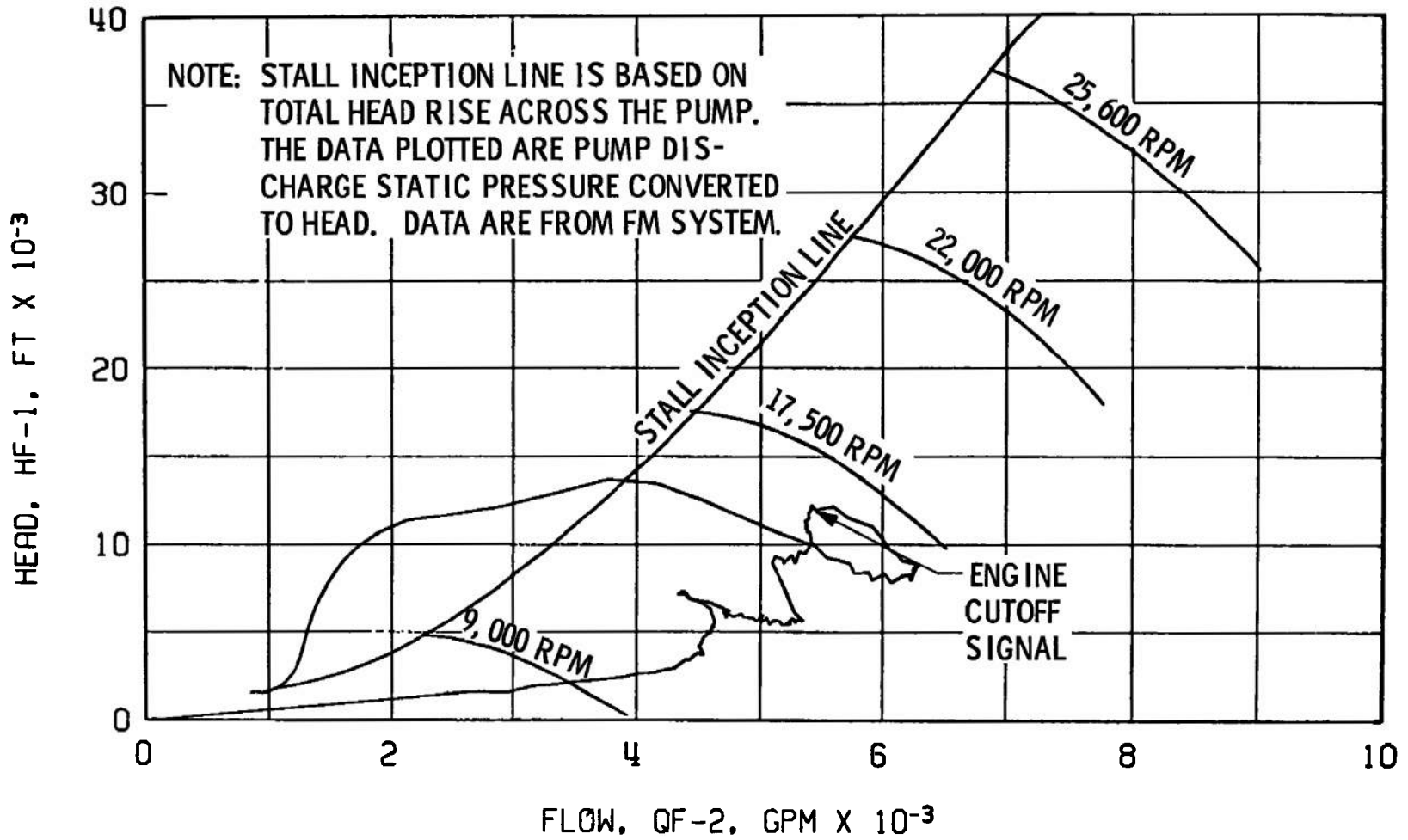

Fig. 27 Fuel Pump Start Transient Performance, Firing 37E

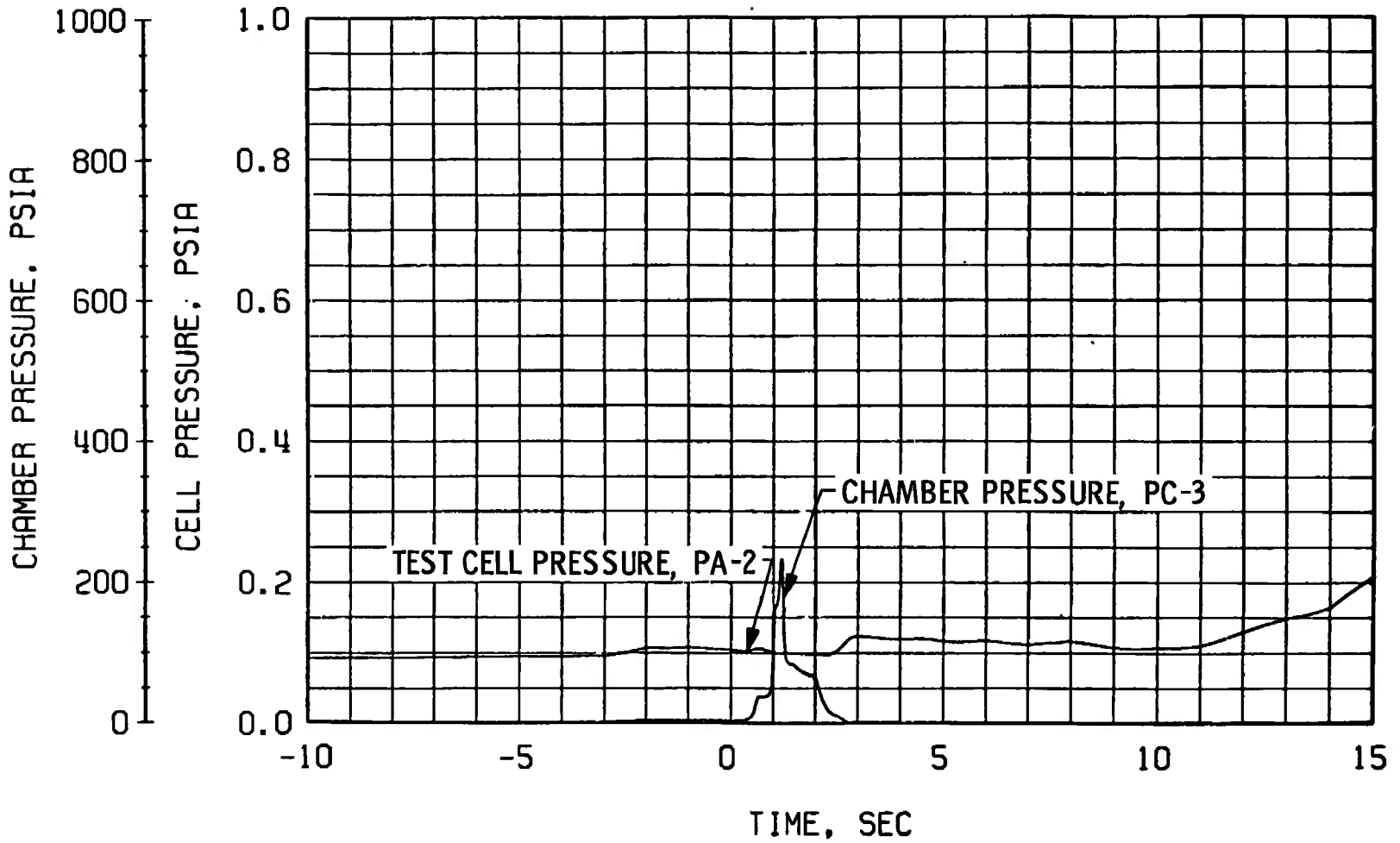
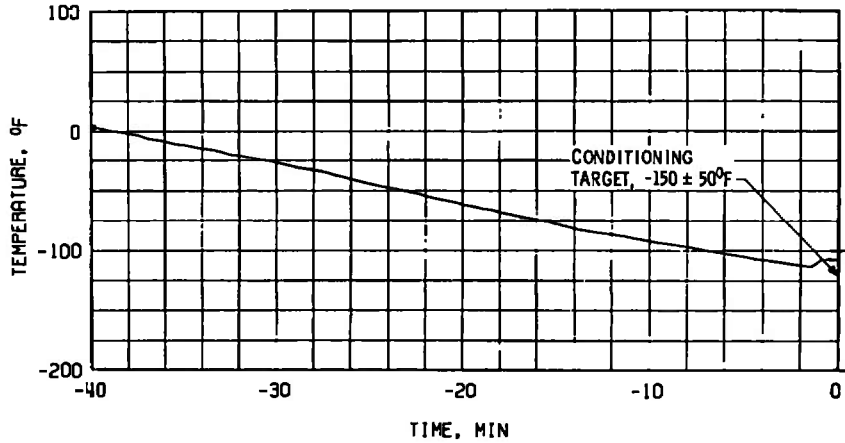
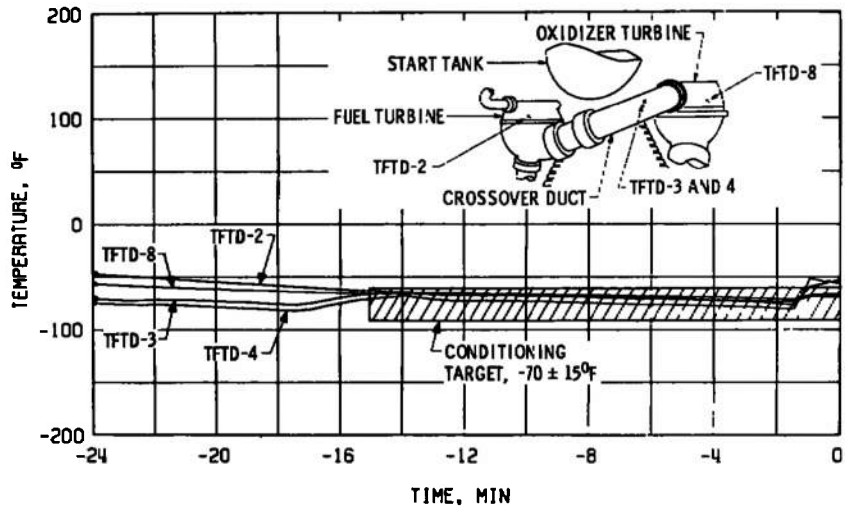

Fig. 28 Engine Ambient and Combustion Chamber Pressures, Firing 37E



a. Main Oxidizer Valve Second-Stage Actuator, TSOVC-1



b. Crossover Duct, TTFD

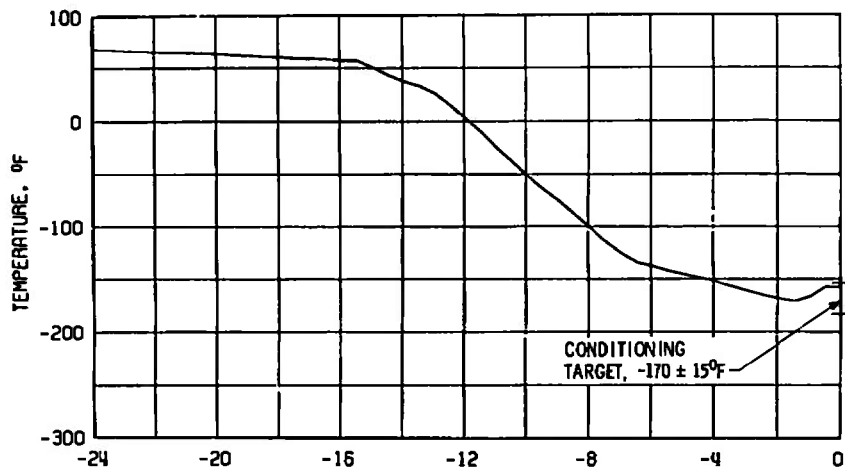

c. Thrust Chamber Throat, TTC-1P

Fig. 29 Thermal Conditioning History of Engine Components, Firing 38A

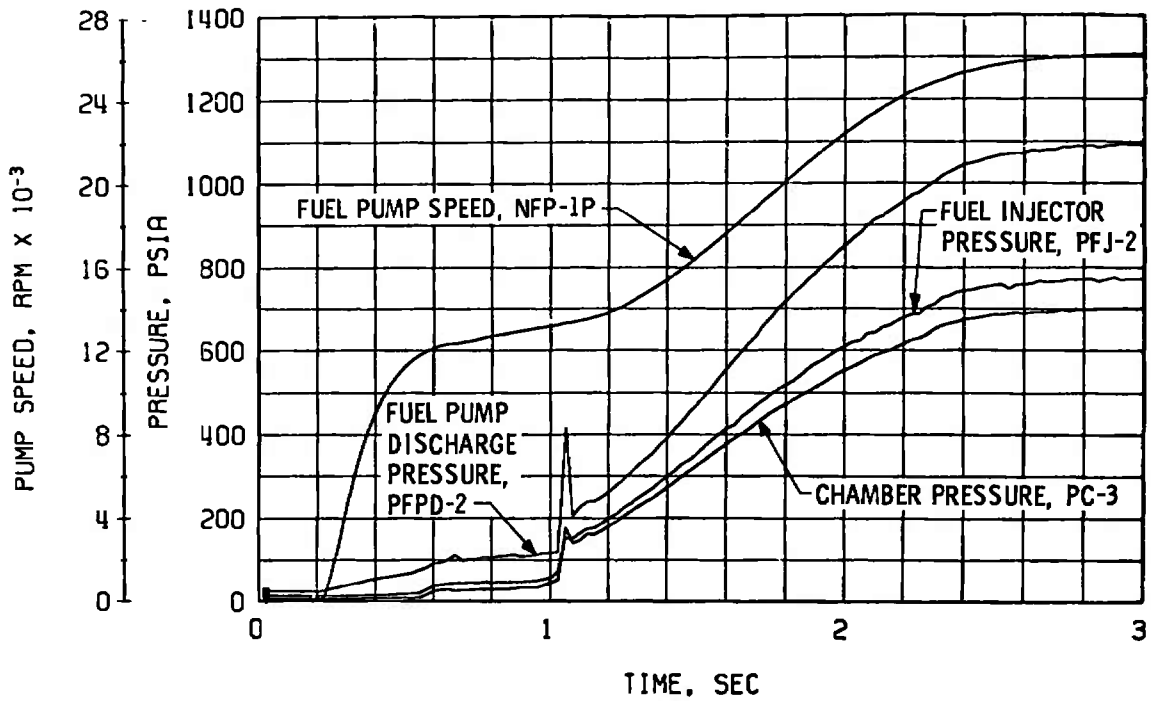

a. Thrust Chamber Fuel System, Start

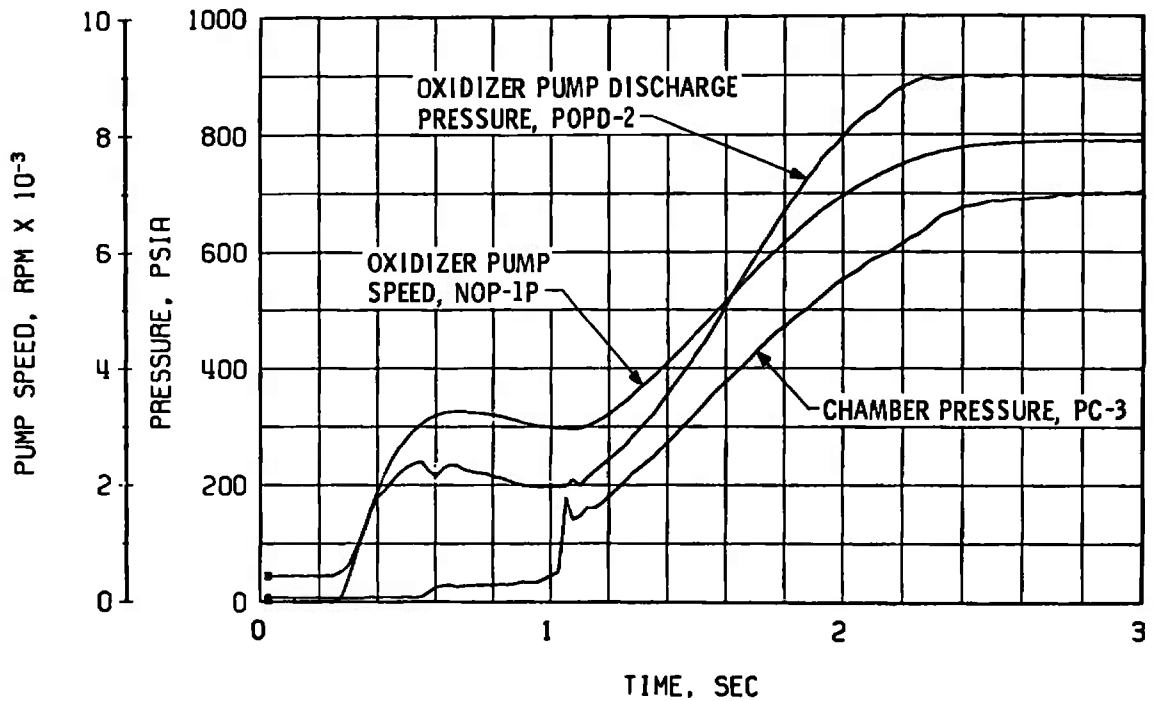

b. Thrust Chamber Oxidizer System, Start
 Fig. 30 Engine Transient Operation, Firing 38A

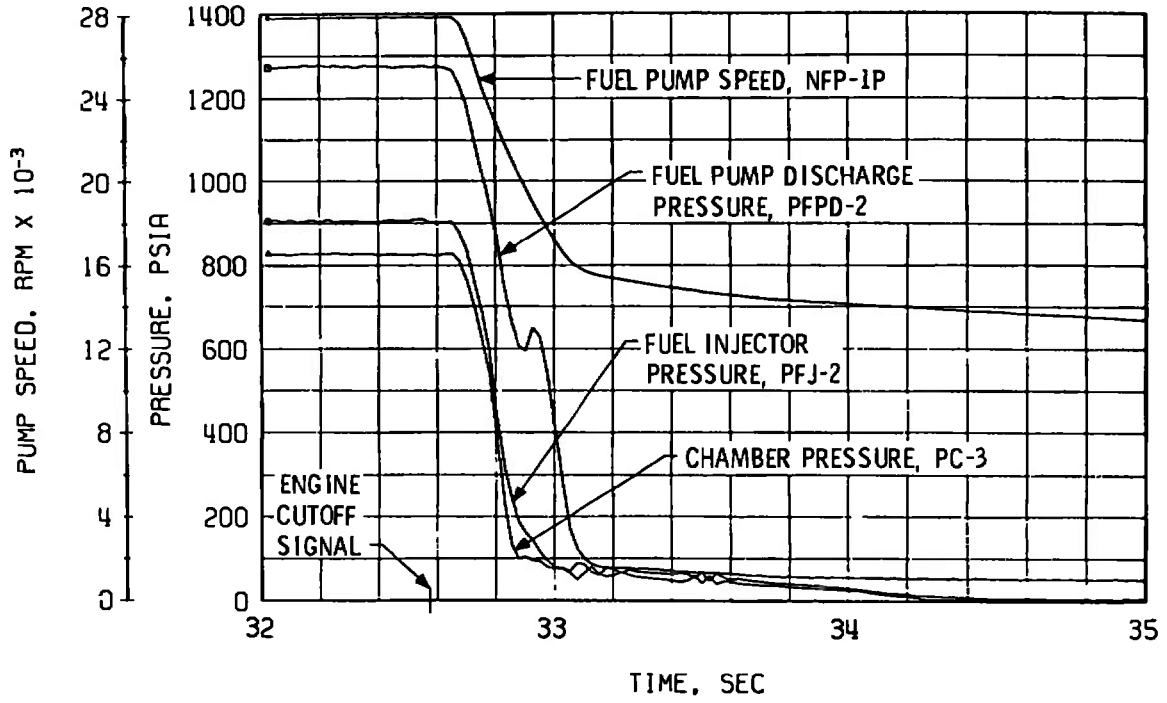

c. Thrust Chamber Fuel System, Shutdown

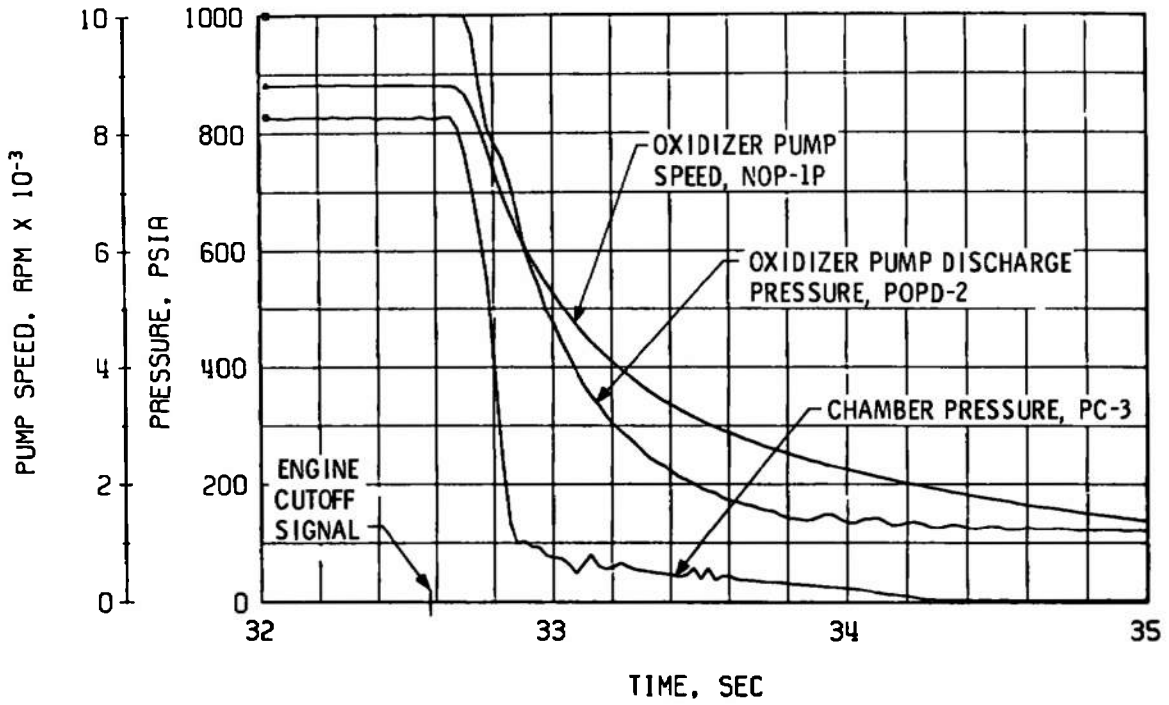

d. Thrust Chamber Oxidizer System, Shutdown

Fig. 30 Continued

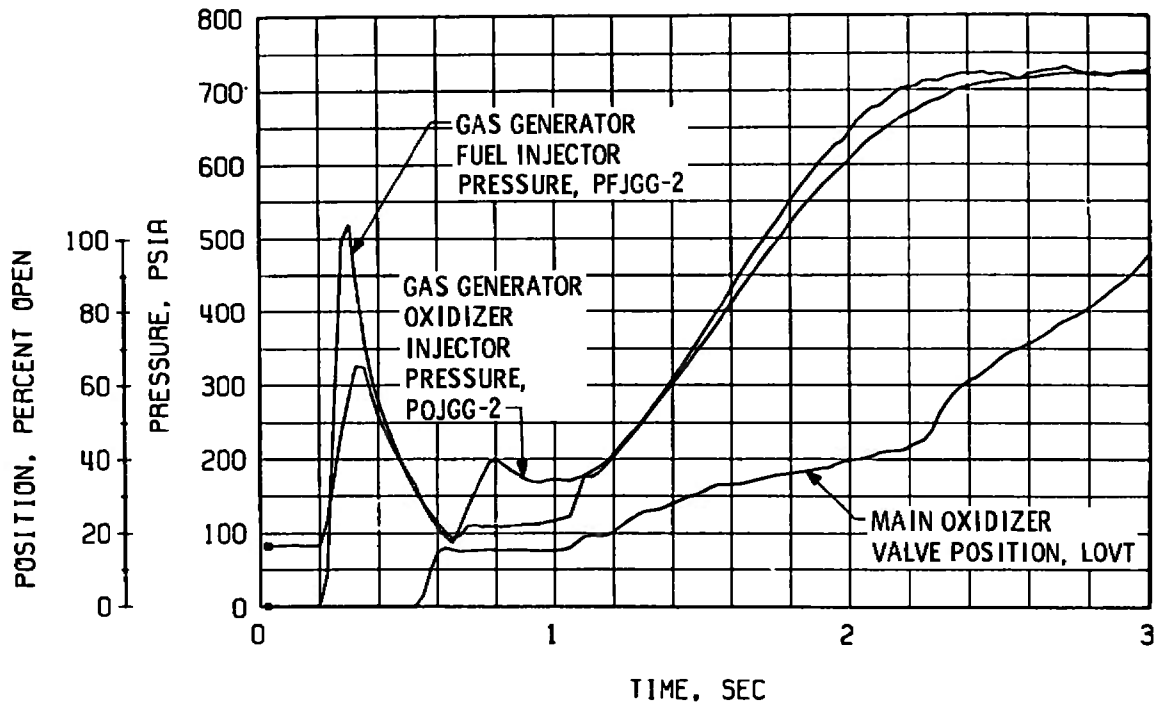

e. Gas Generator Injector Pressures and Main Oxidizer Valve Position, Start

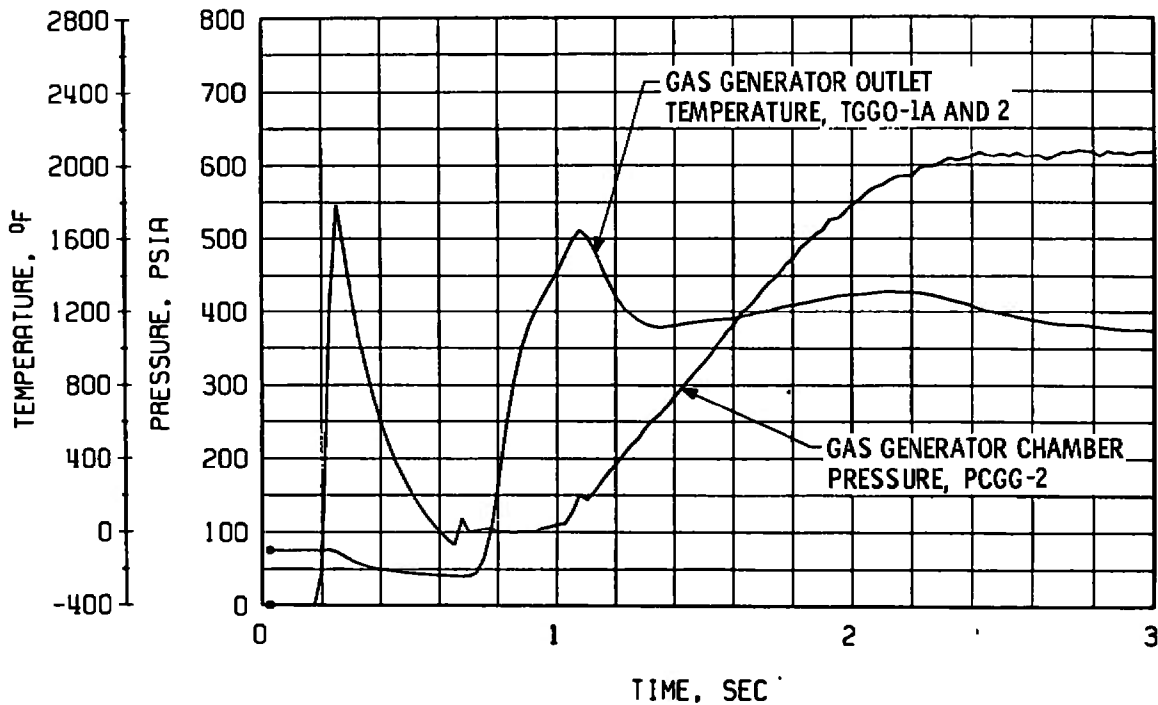

f. Gas Generator Chamber Pressure and Temperature, Start

Fig. 30 Continued

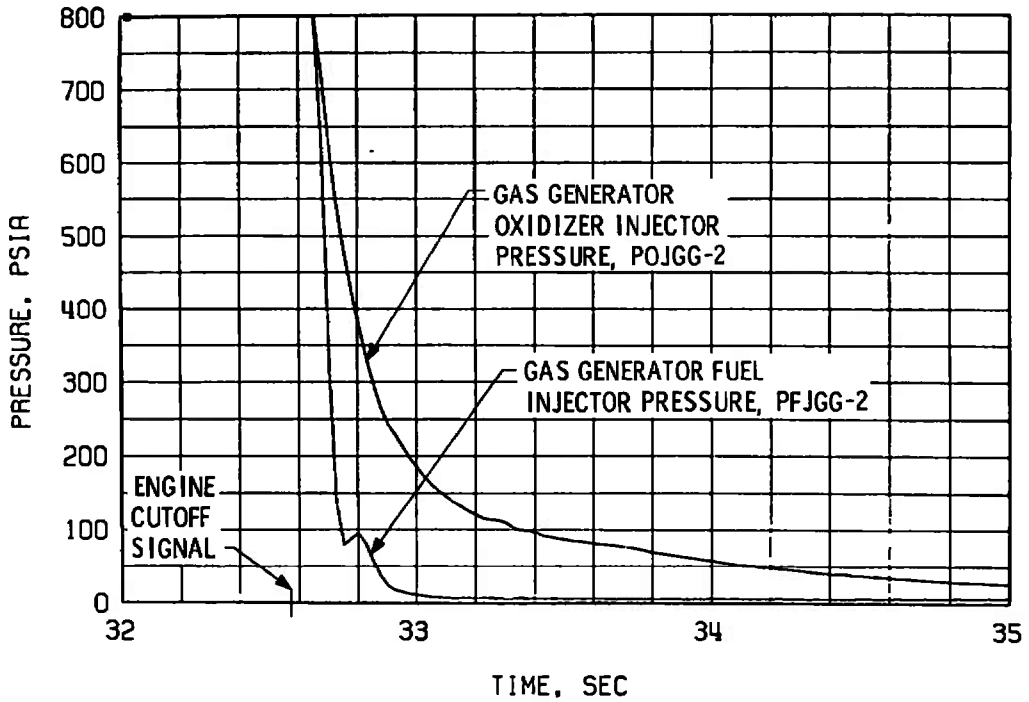

g. Gas Generator Injector Pressures, Shutdown

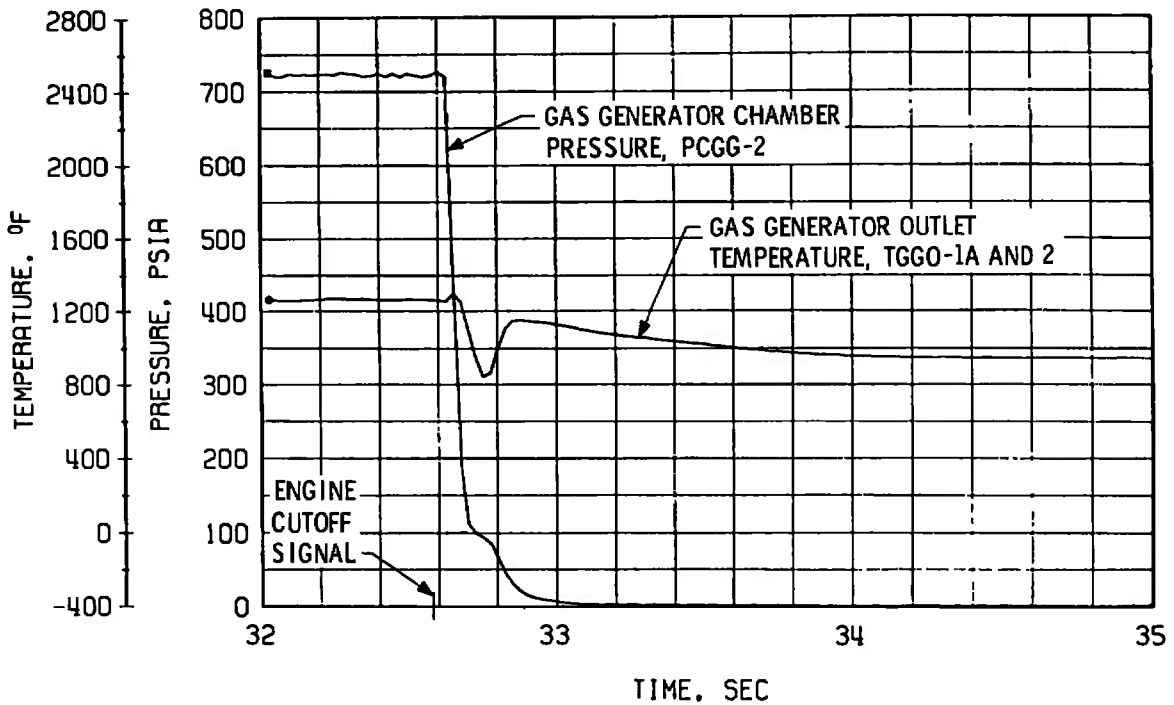

h. Gas Generator Chamber Pressure and Temperature, Shutdown

Fig. 30 Concluded

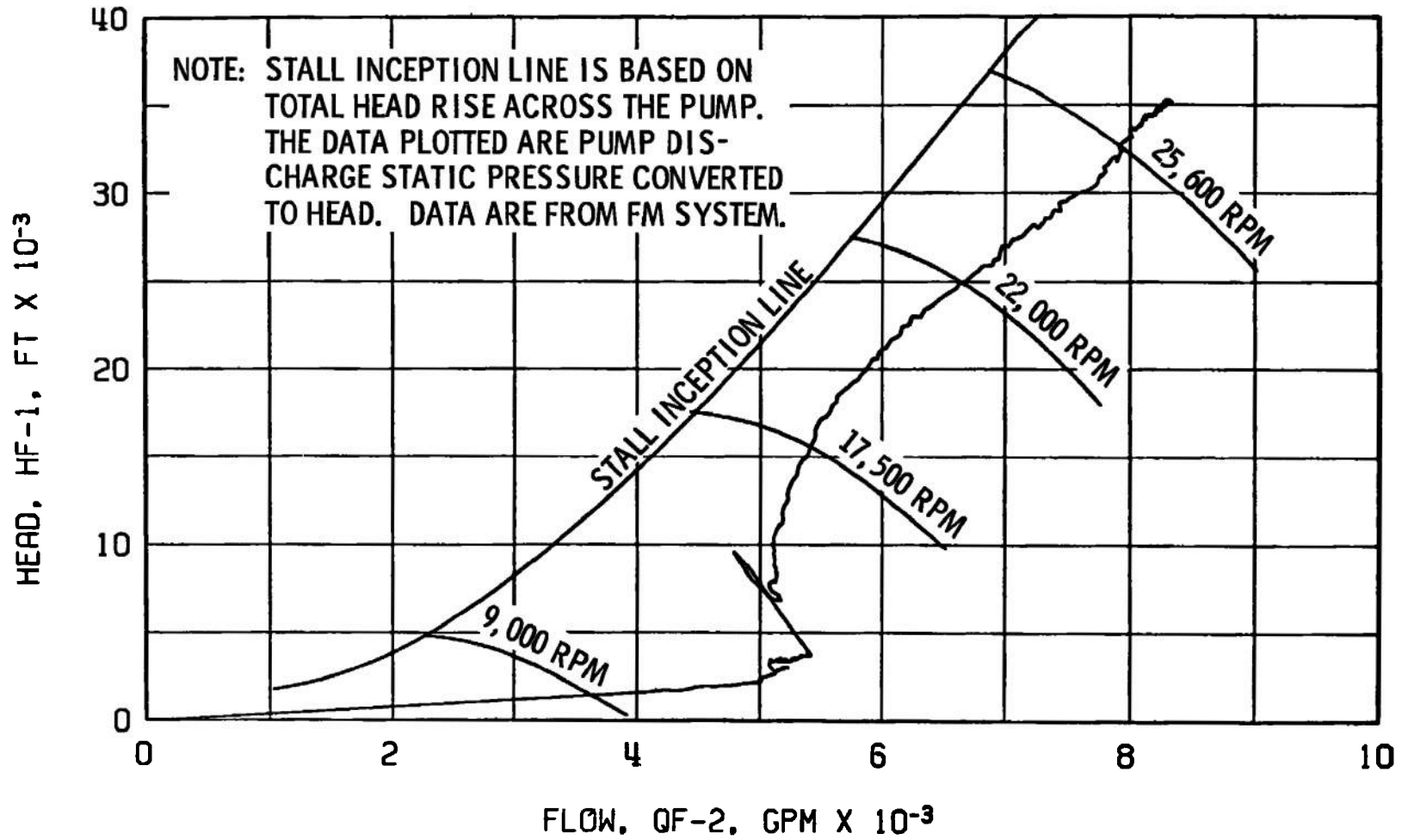

Fig. 31 Fuel Pump Start Transient Performance, Firing 38A

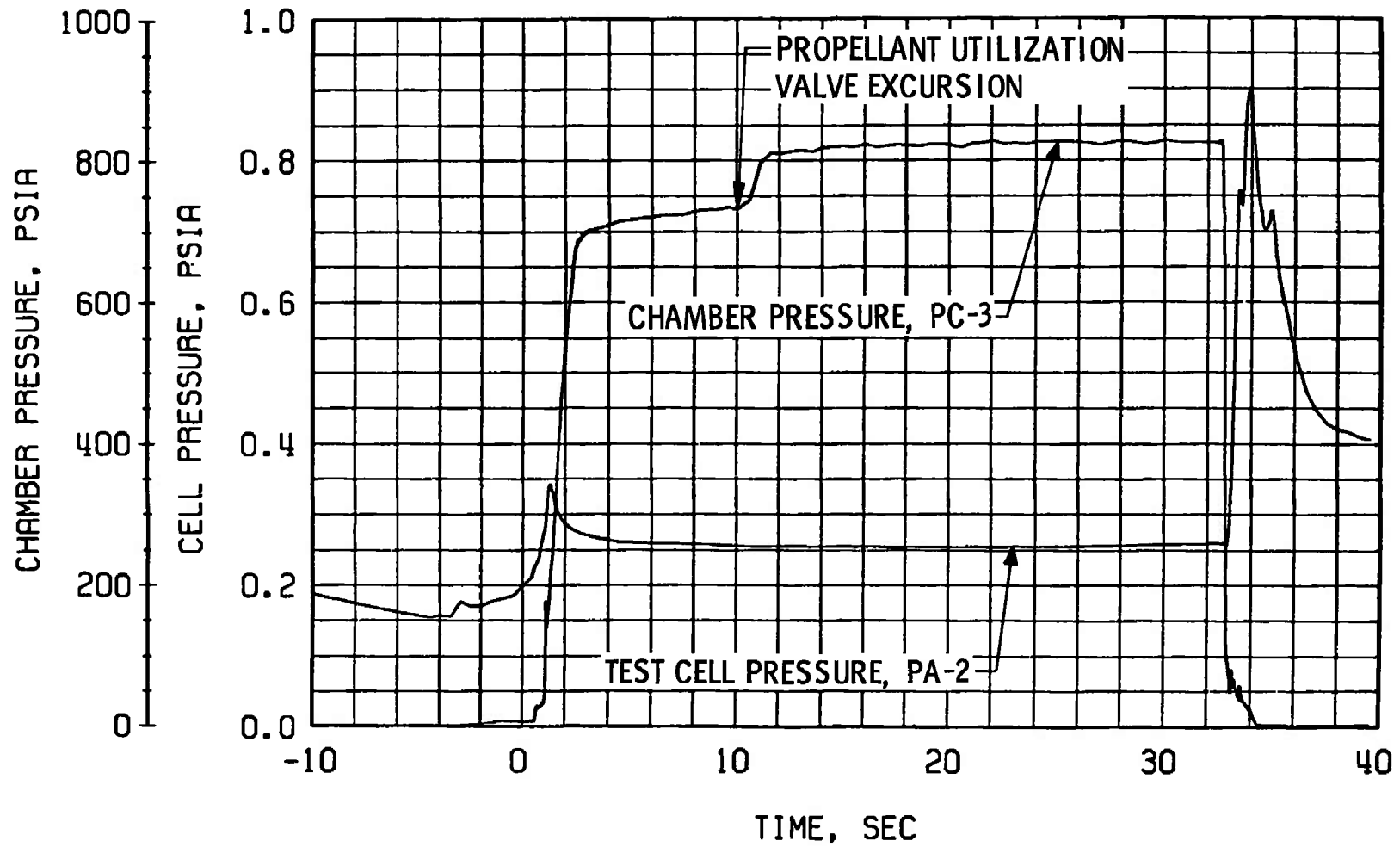
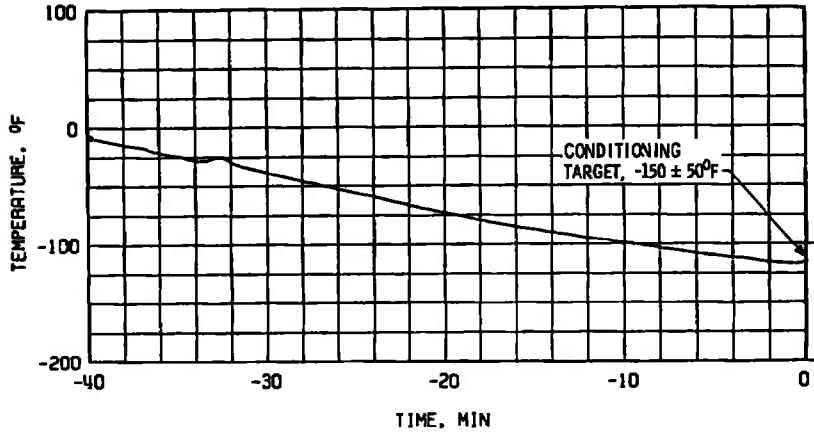
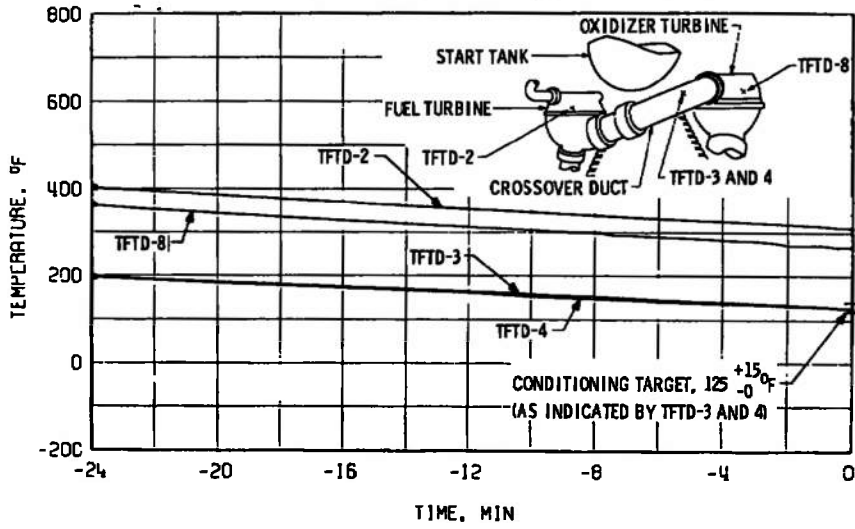

Fig. 32 Engine Ambient and Combustion Chamber Pressures, Firing 38A



a. Main Oxidizer Valve Second-Stage Actuator, TSOVC-1



b. Crossover Duct, TFTD

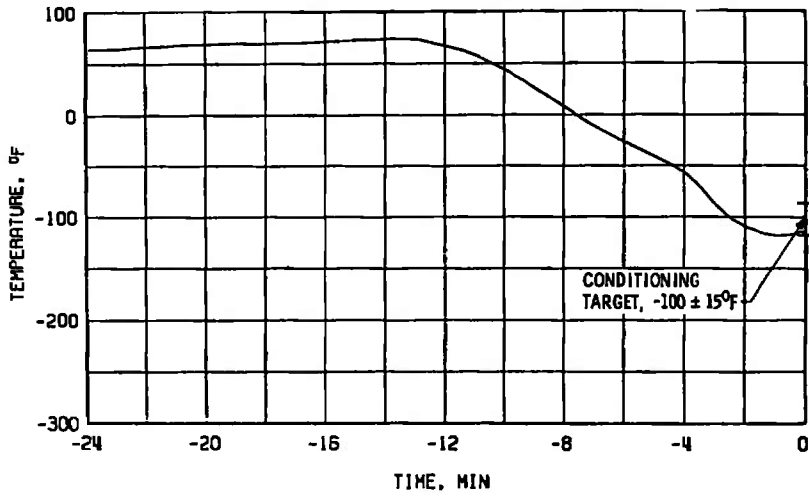

c. Thrust Chamber Throat, TTC-1P

Fig. 33 Thermal Conditioning History of Engine Components, Firing 38B

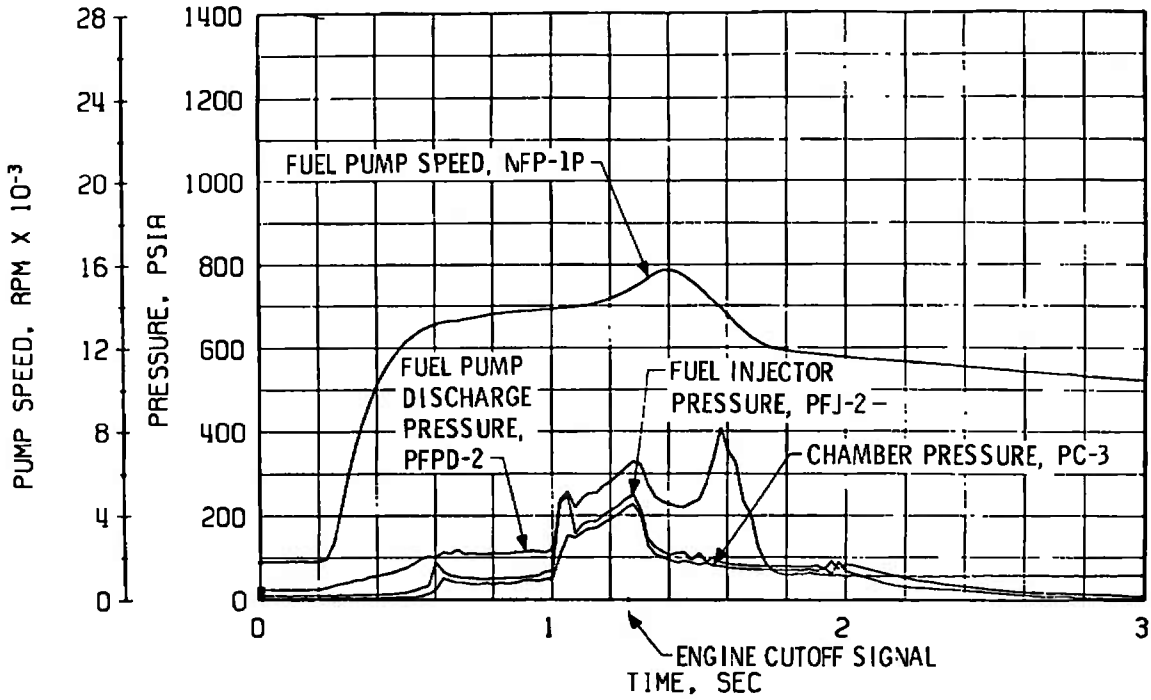

a. Thrust Chamber Fuel System, Start

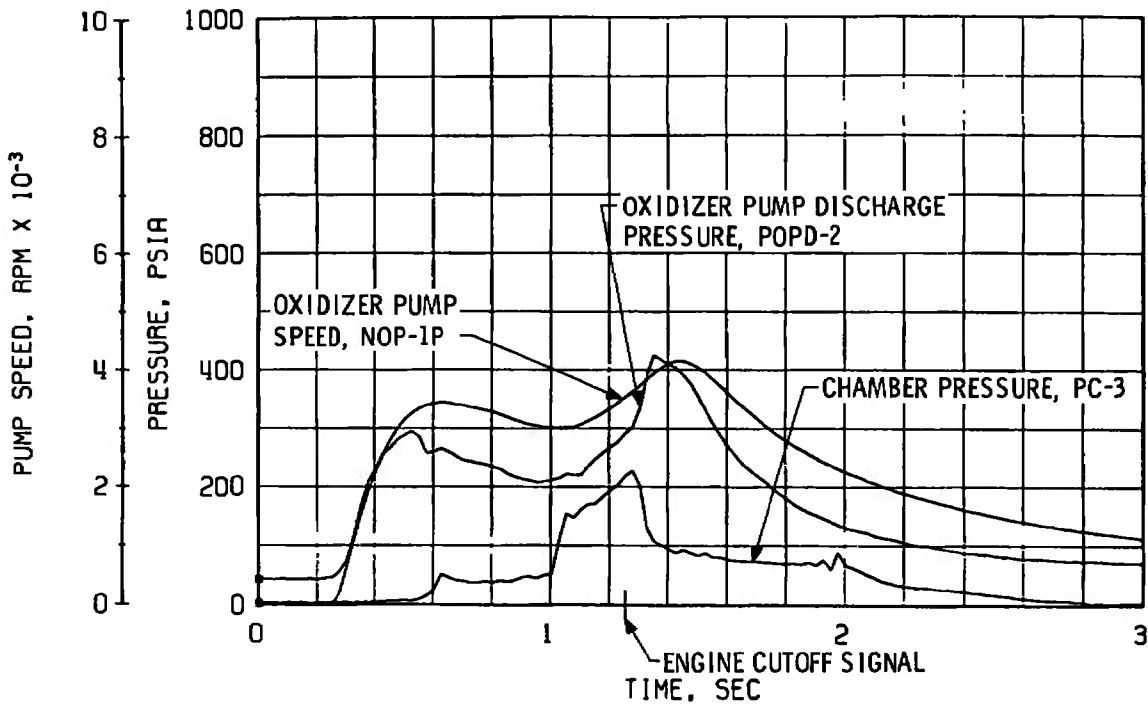

b. Thrust Chamber Oxidizer System, Start

Fig. 34 Engine Transient Operation, Firing 38B

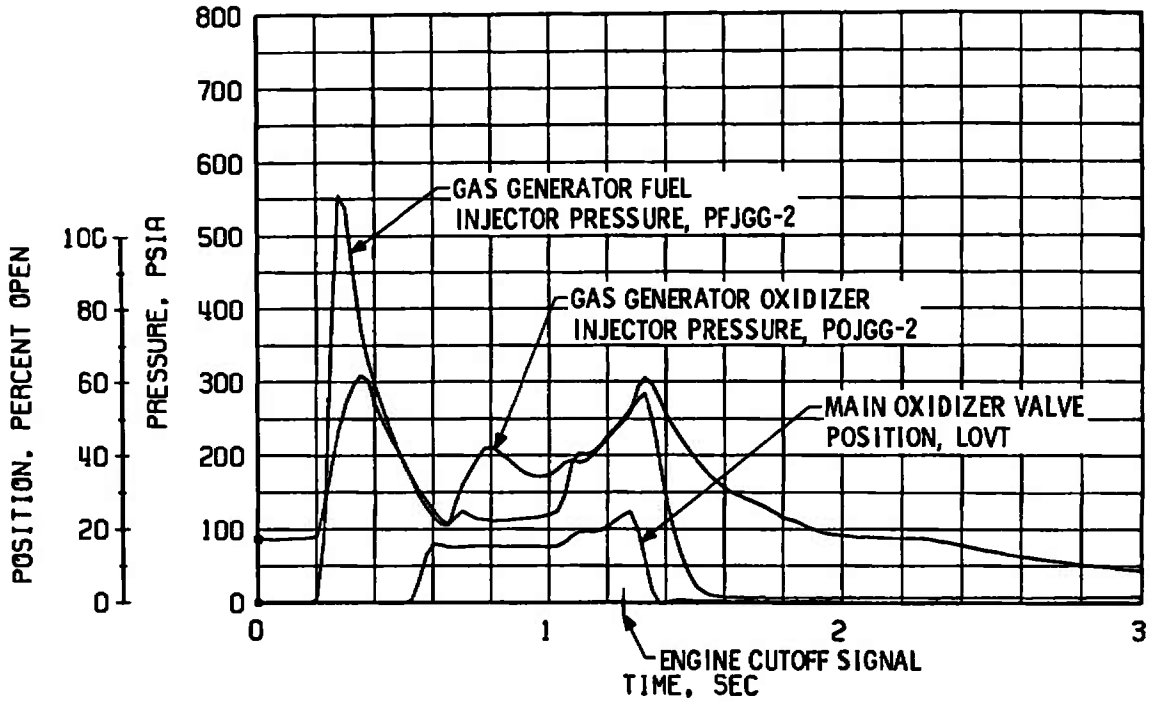

c. Gas Generator Injector Pressures and Main Oxidizer Valve Position, Start

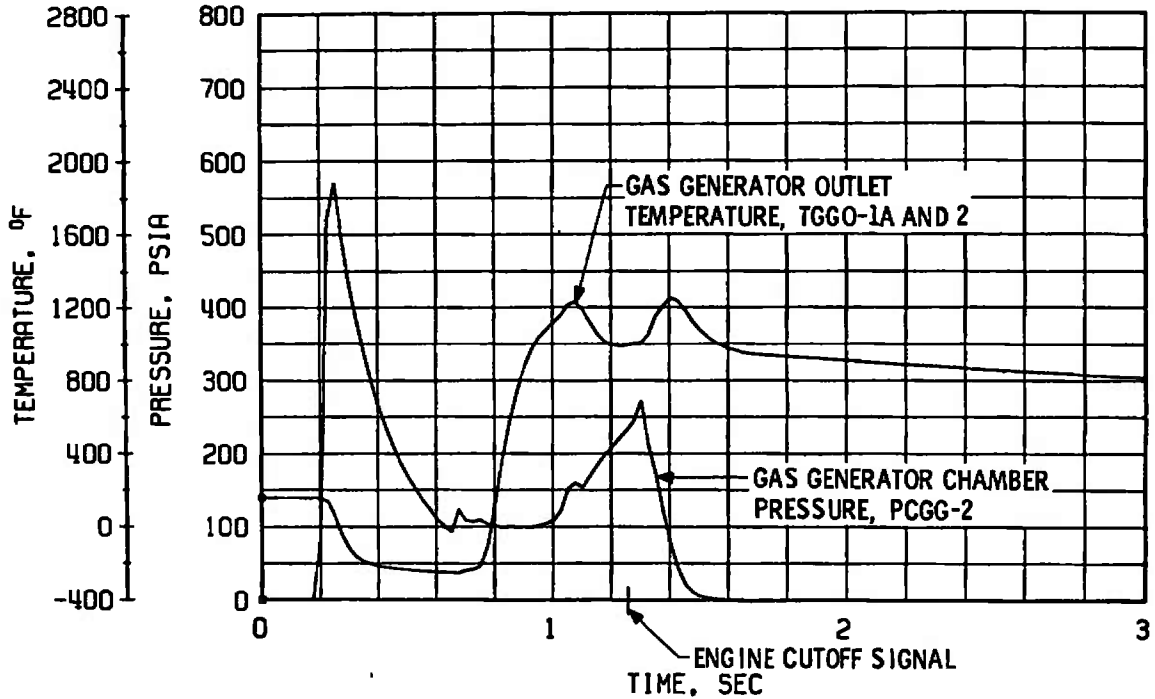

d. Gas Generator Chamber Pressure and Temperature, Start

Fig. 34 Concluded

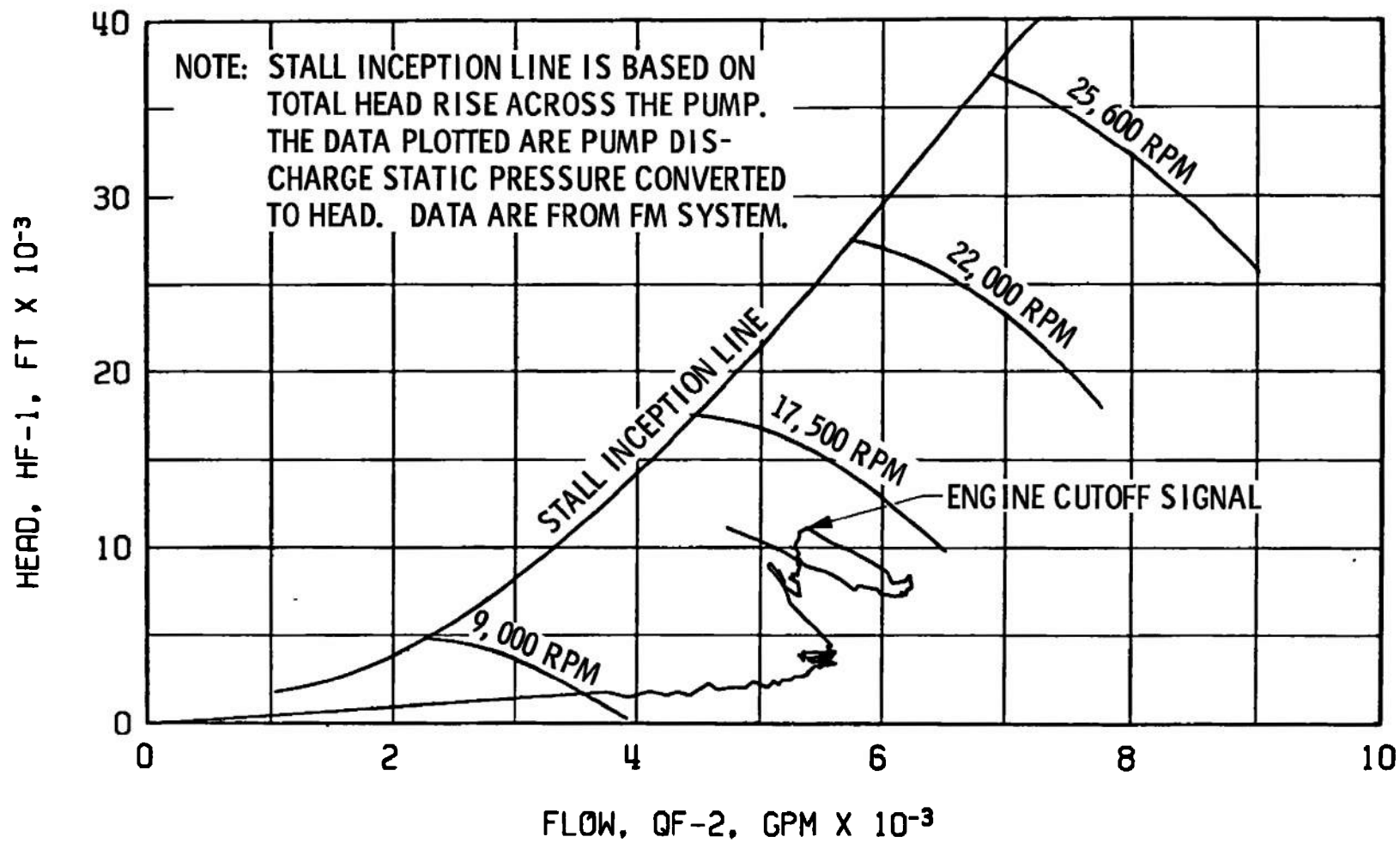

Fig. 35 Fuel Pump Start Transient Performance, Firing 38B

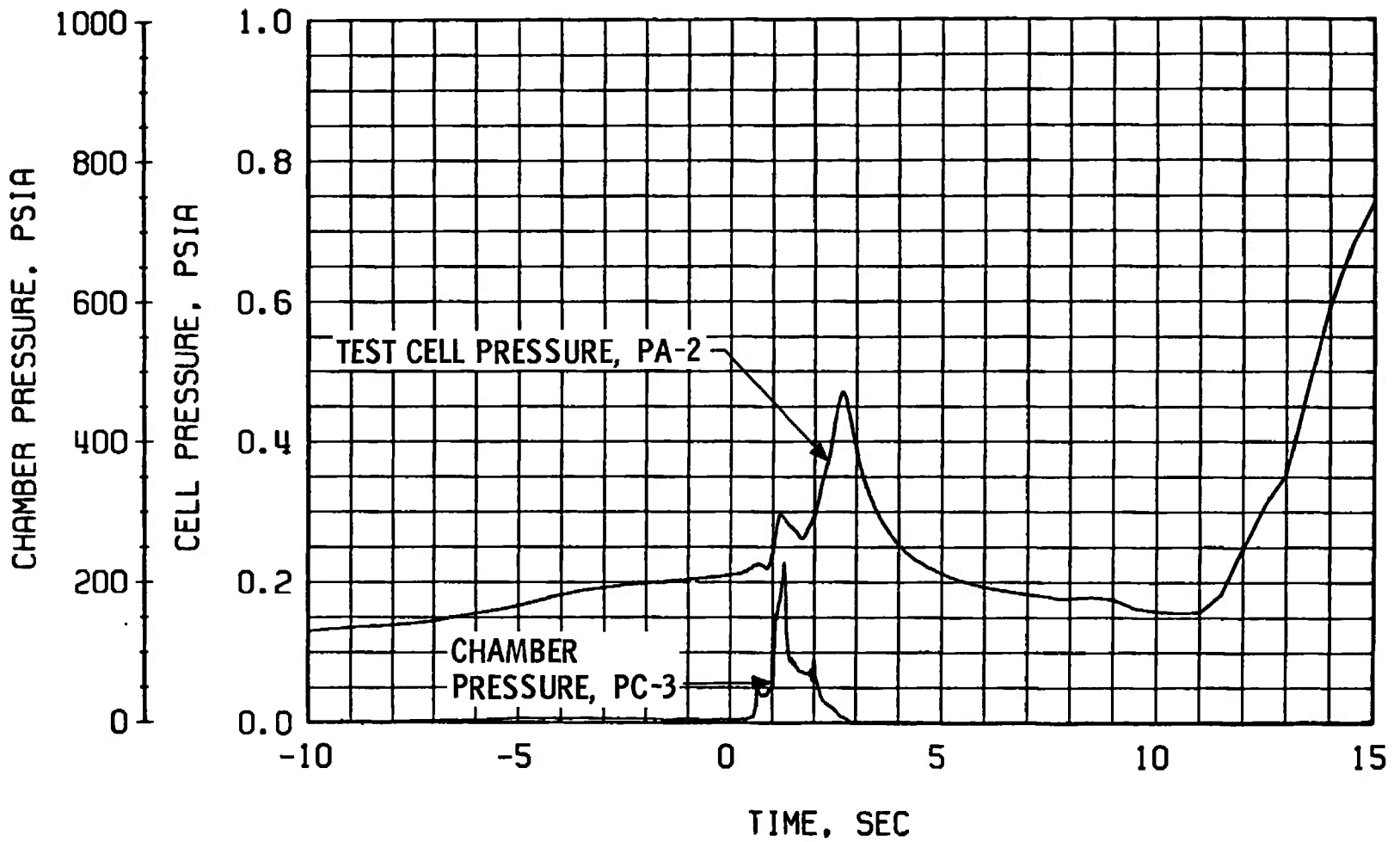
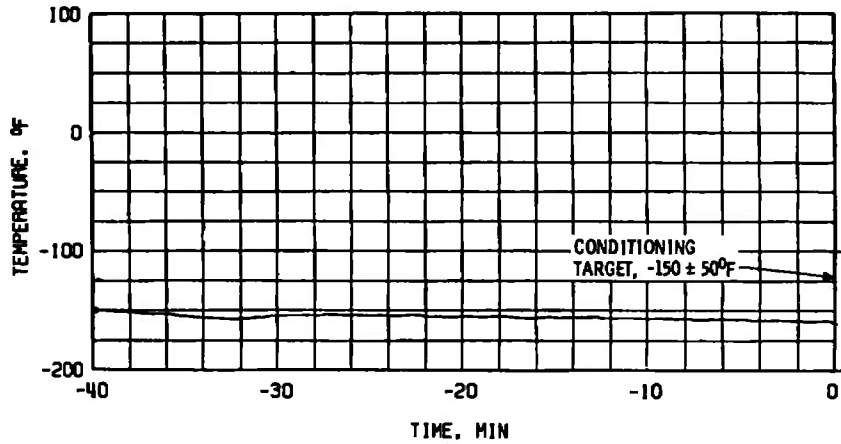
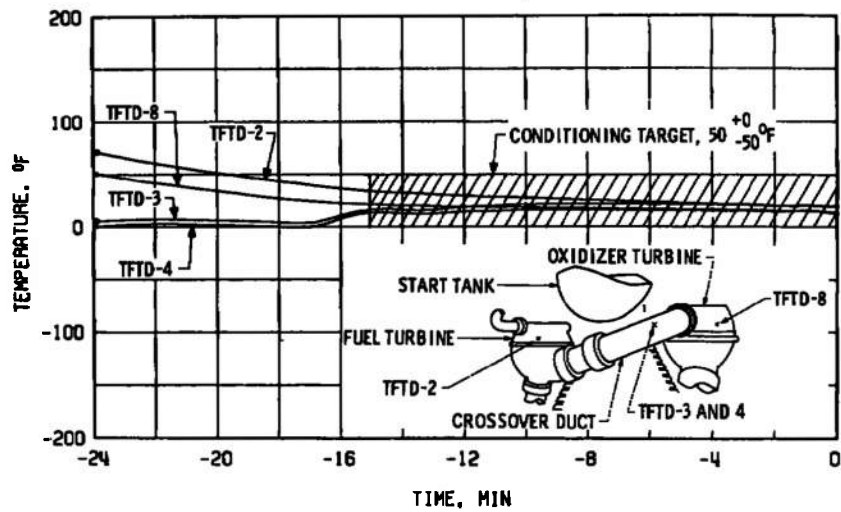

Fig. 36 Engine Ambient and Combustion Chamber Pressures, Firing 38B



a. Main Oxidizer Valve Second-Stage Actuator, TSOVC-1



b. Crossover Duct, TFTD

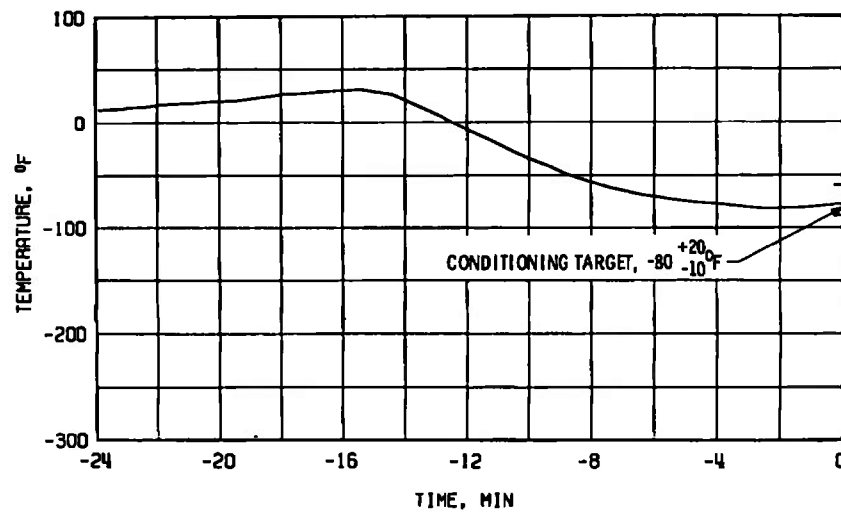

c. Thrust Chamber Throat, TTC-1P

Fig. 37 Thermal Conditioning History of Engine Components, Firing 38C

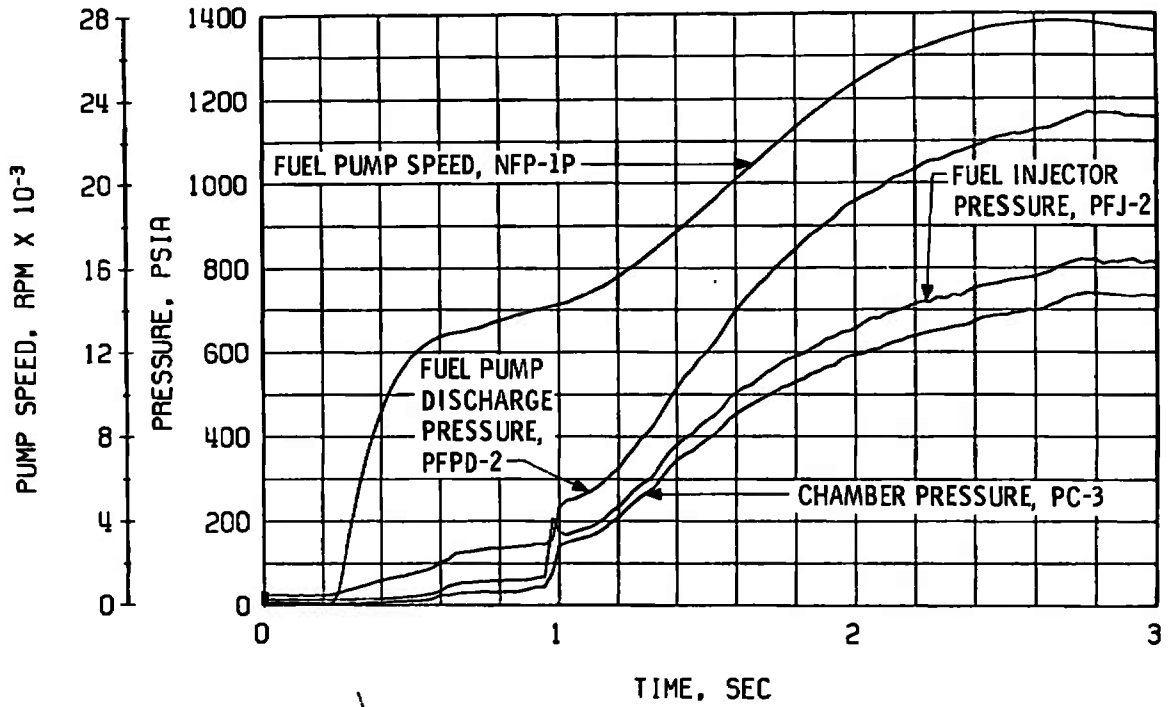

a. Thrust Chamber Fuel System, Start

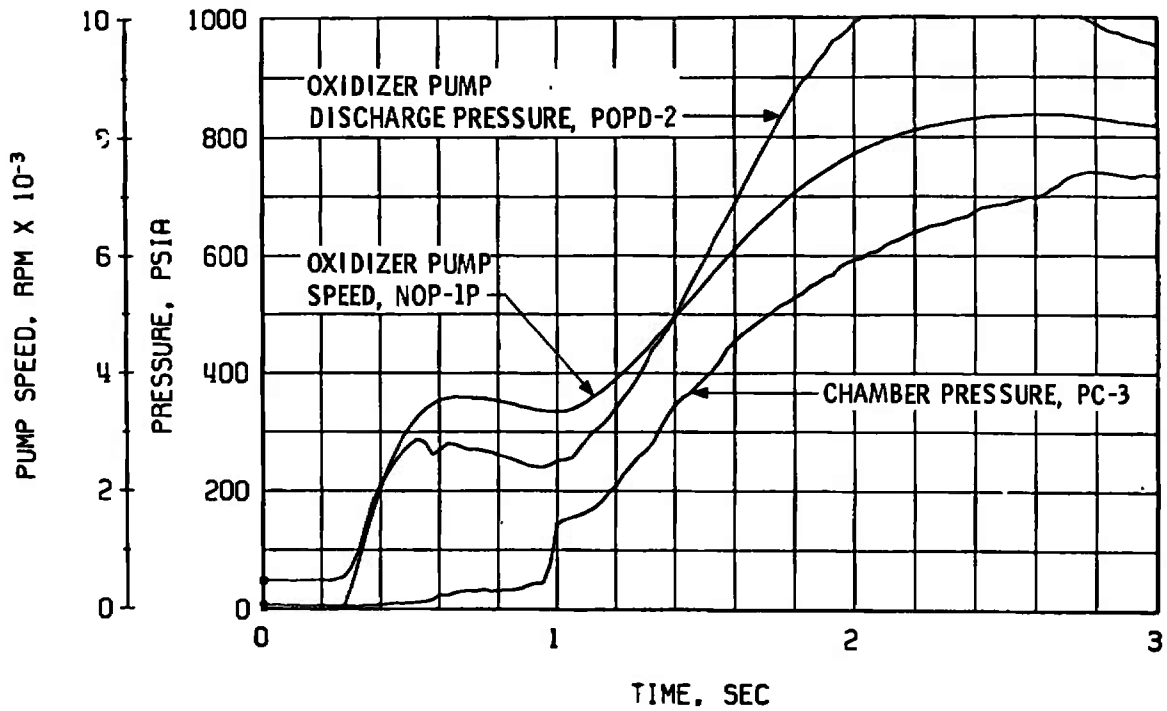

b. Thrust Chamber Oxidizer System, Start

Fig. 38 Engine Transient Operation, Firing 38C

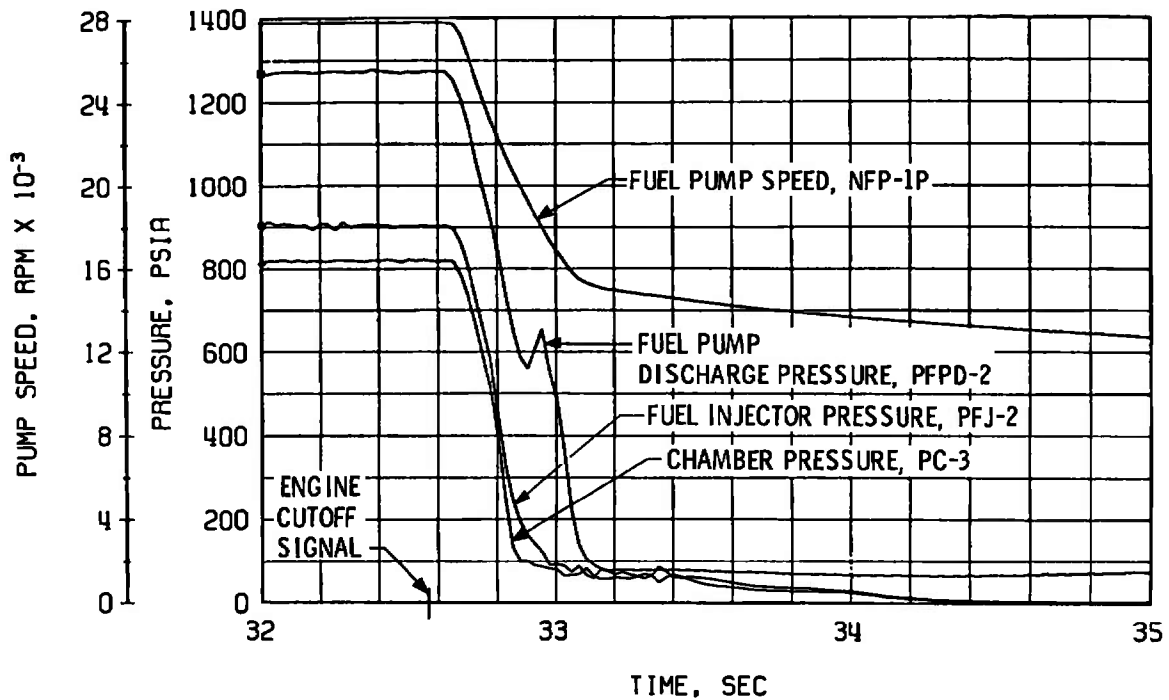

c. Thrust Chamber Fuel System, Shutdown

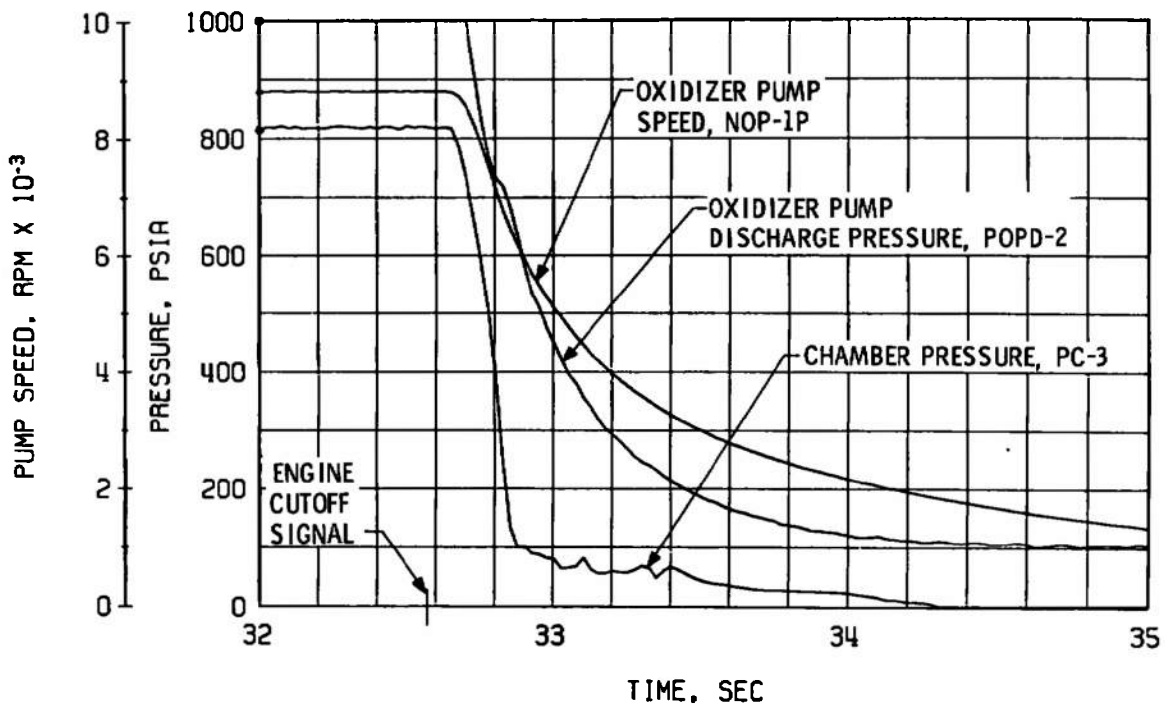

d. Thrust Chamber Oxidizer System, Shutdown

Fig. 38 Continued

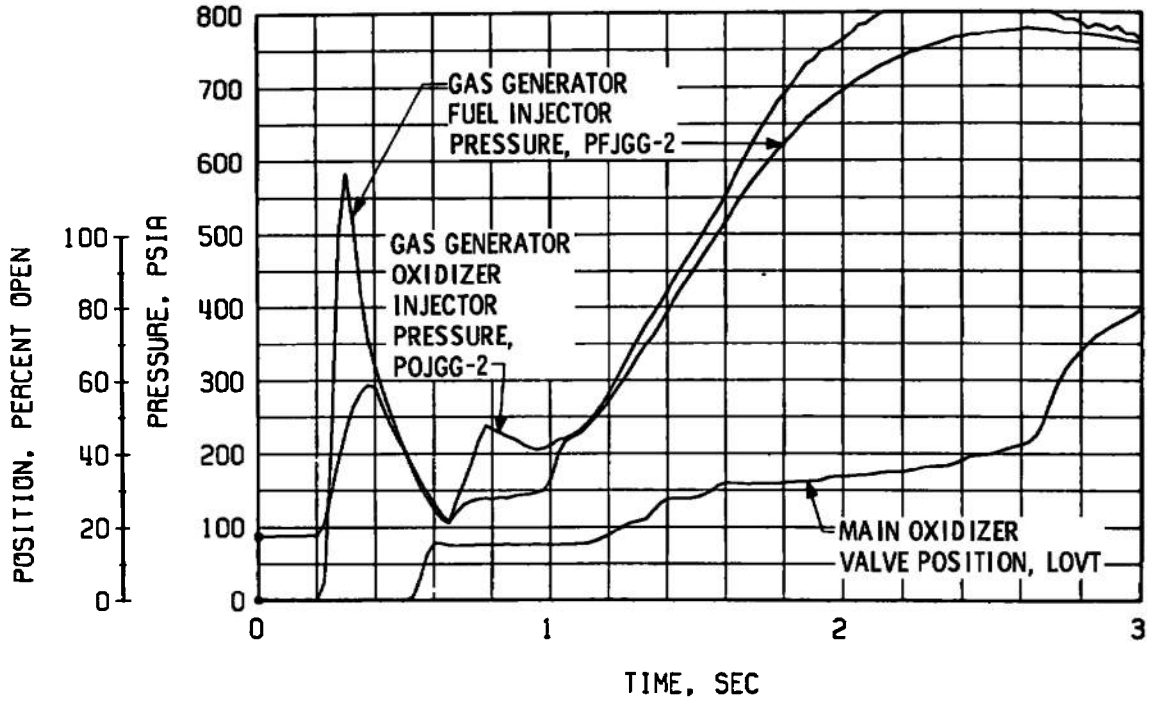

e. Gas Generator Injector Pressures and Main Oxidizer Valve Position, Start

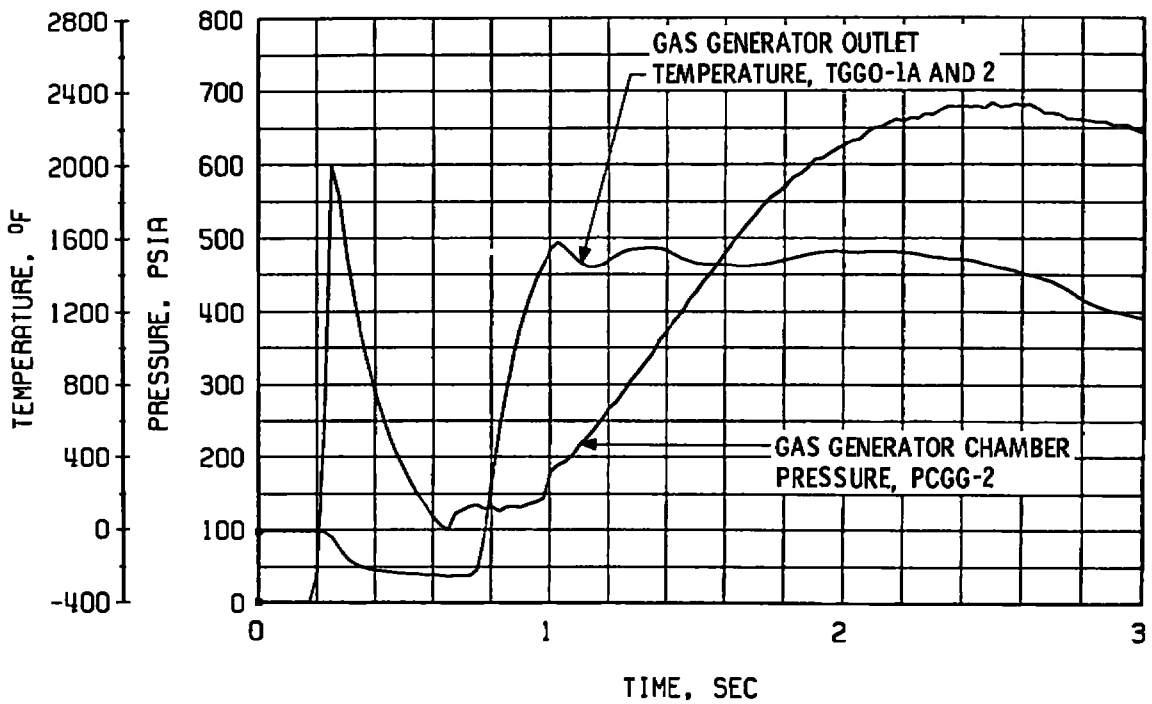

f. Gas Generator Chamber Pressure and Temperature, Start

Fig. 38 Continued

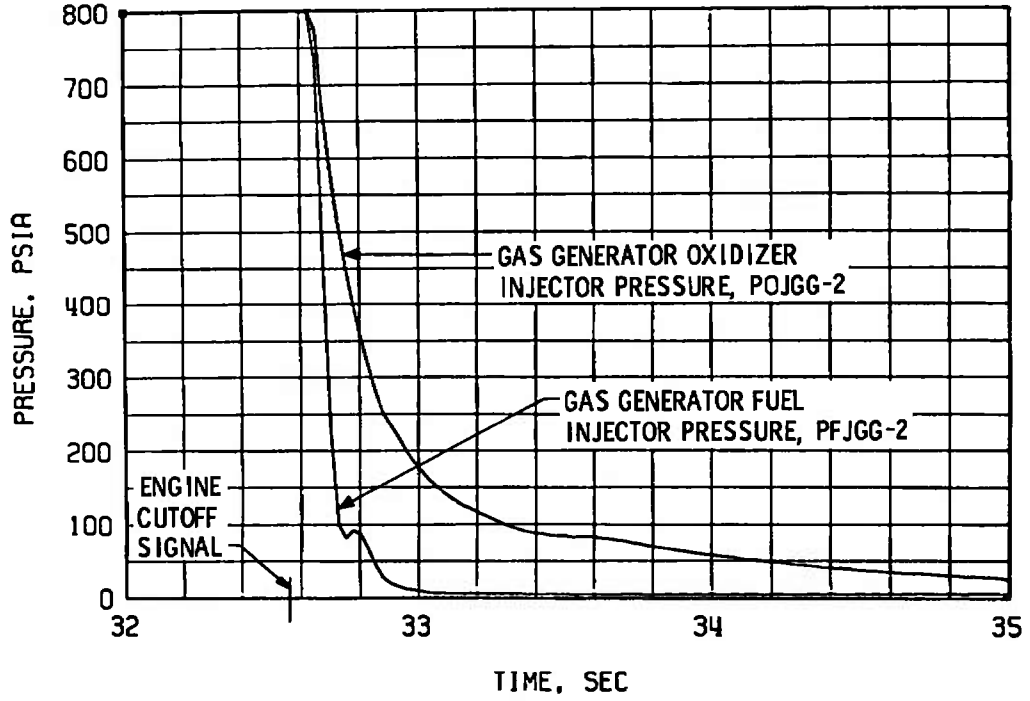

g. Gas Generator Injector Pressures, Shutdown

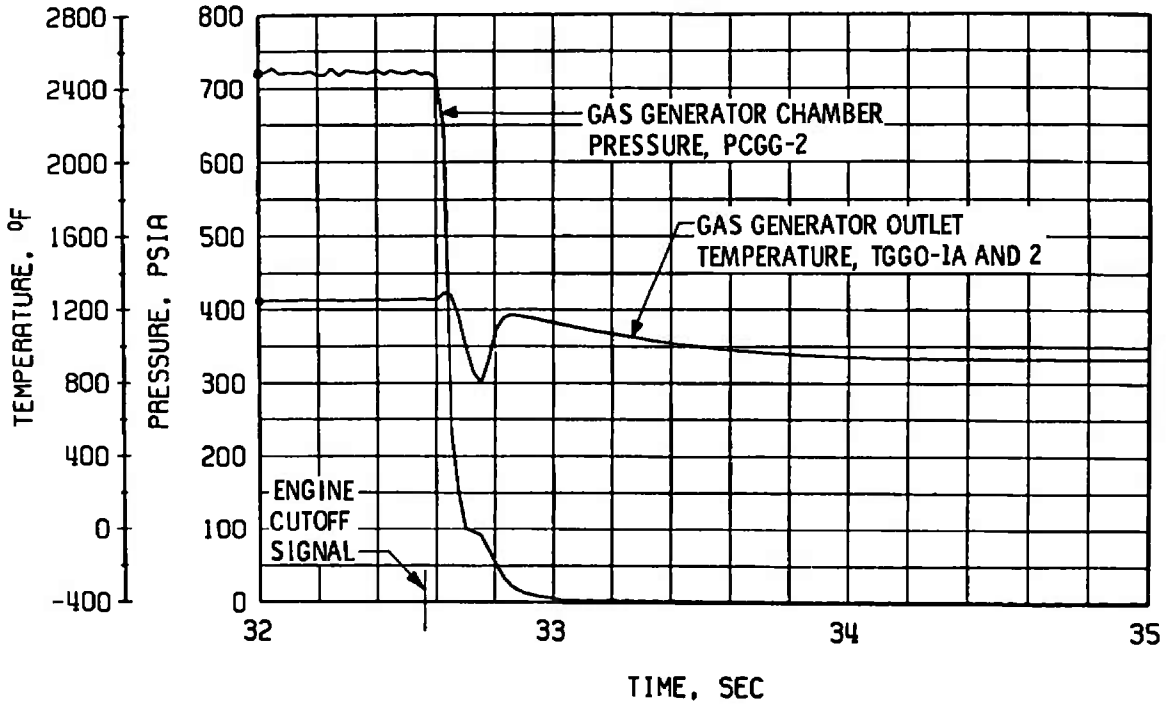

h. Gas Generator Chamber Pressure and Temperature, Shutdown

Fig. 38 Concluded

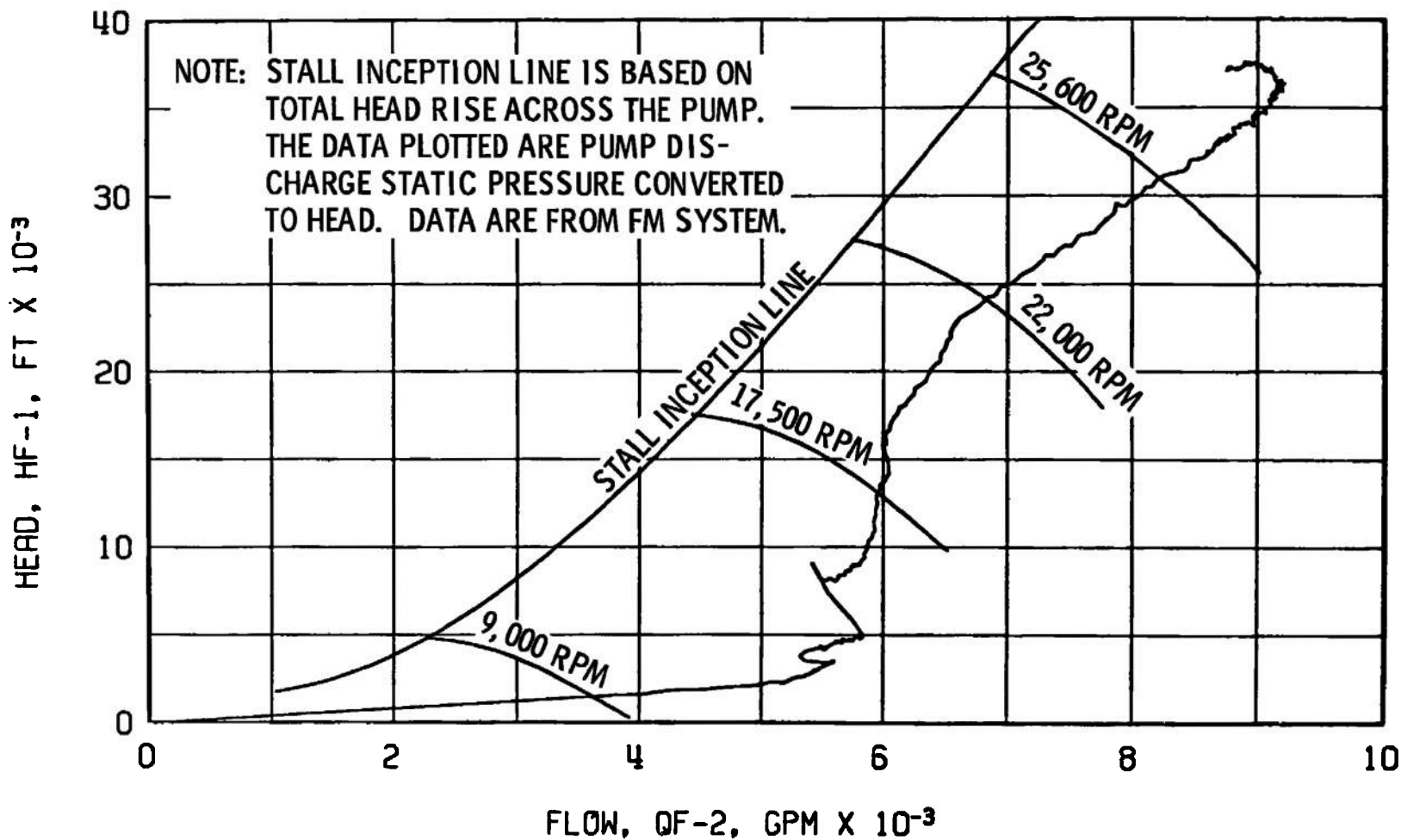

Fig. 39 Fuel Pump Start Transient Performance, Firing 38C

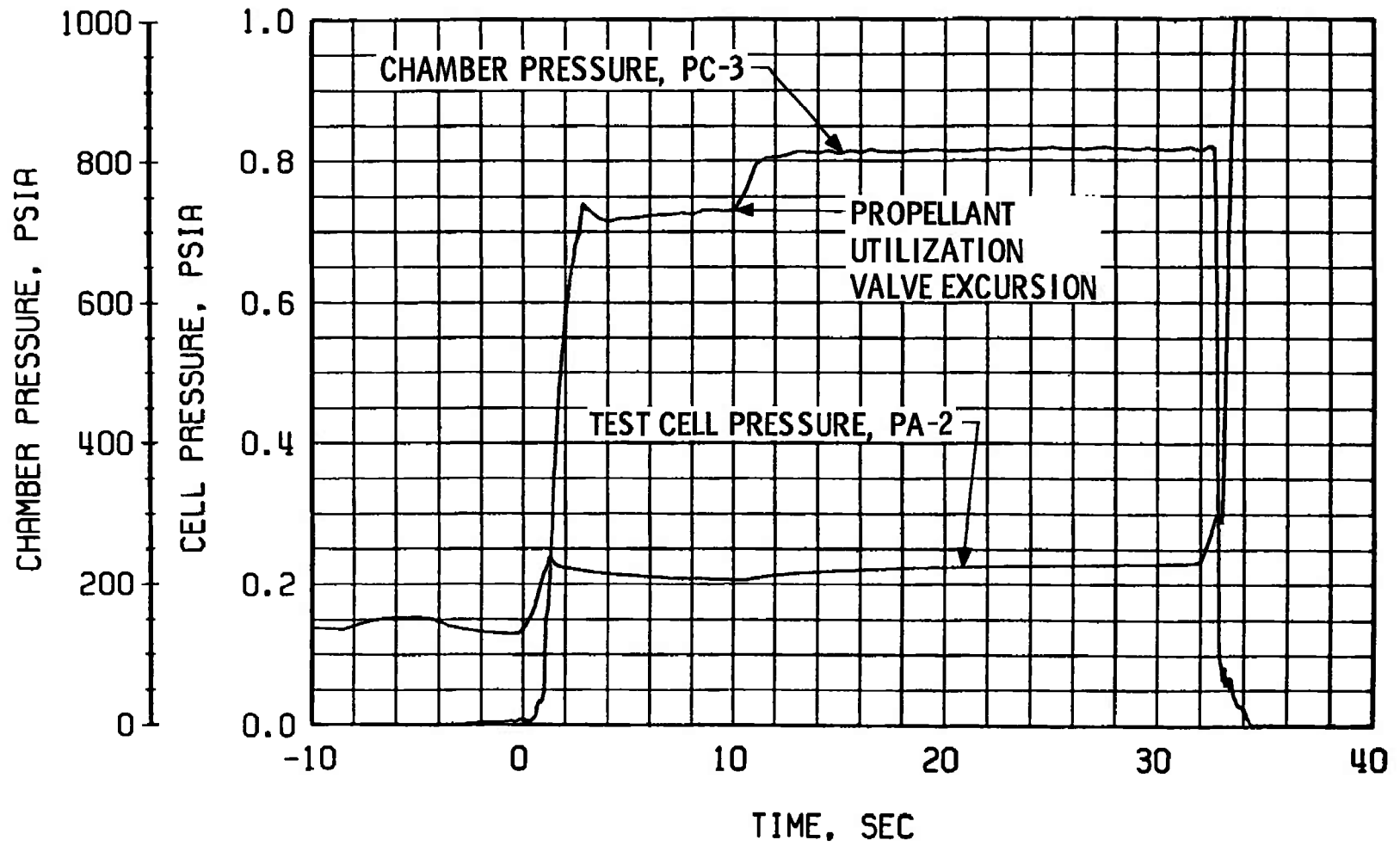
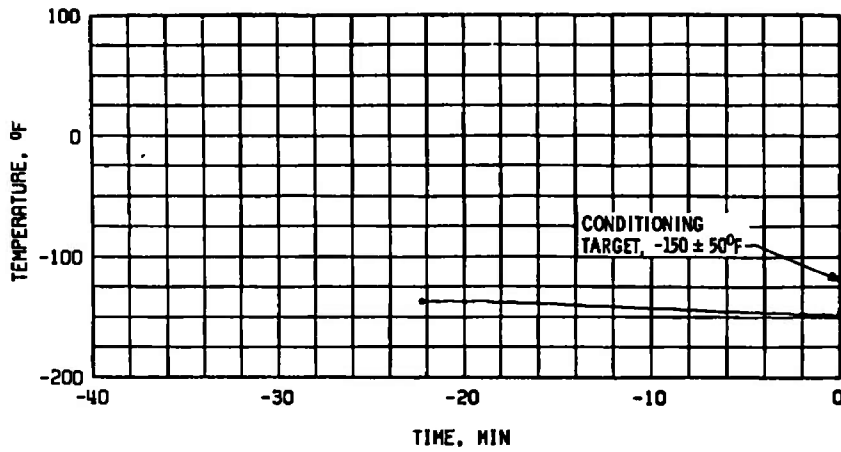
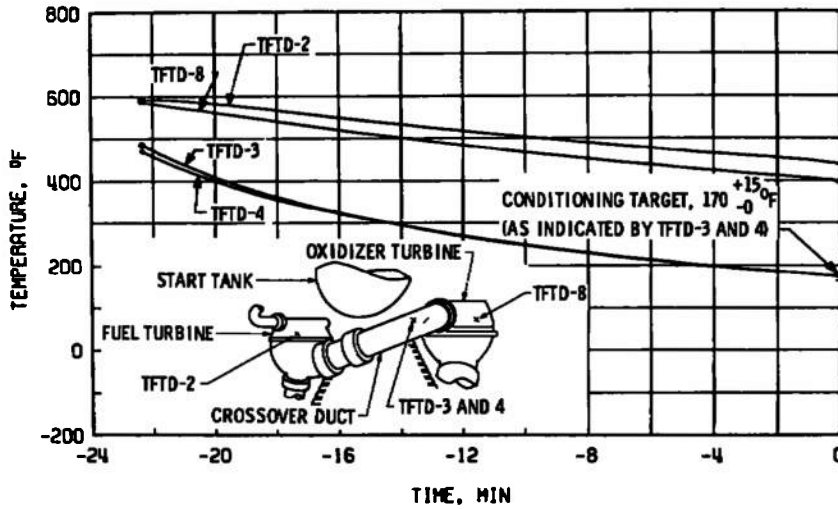

Fig. 40 Engine Ambient and Combustion Chamber Pressures, Firing 38C



a. Main Oxidizer Valve Second-Stage Actuator, TSOVC-1



b. Crossover Duct, TFTD

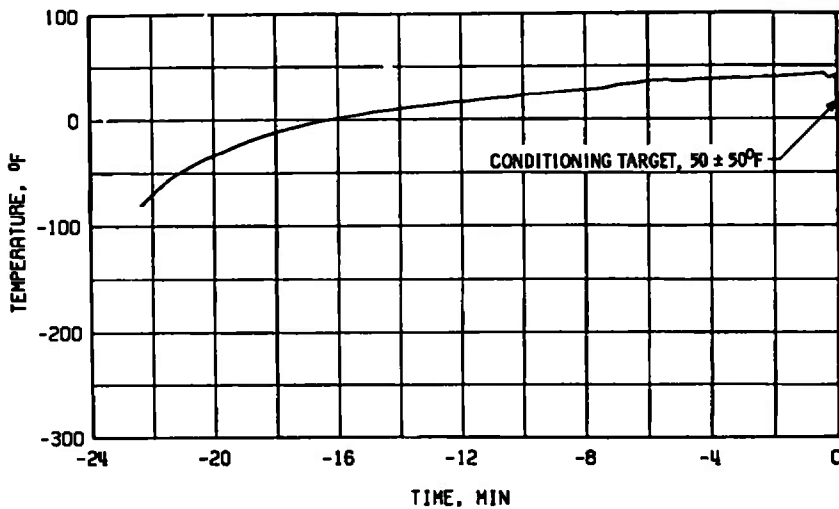

c. Thrust Chamber Throat, TTC-1P

Fig. 41 Thermal Conditioning History of Engine Components, Firing 38D

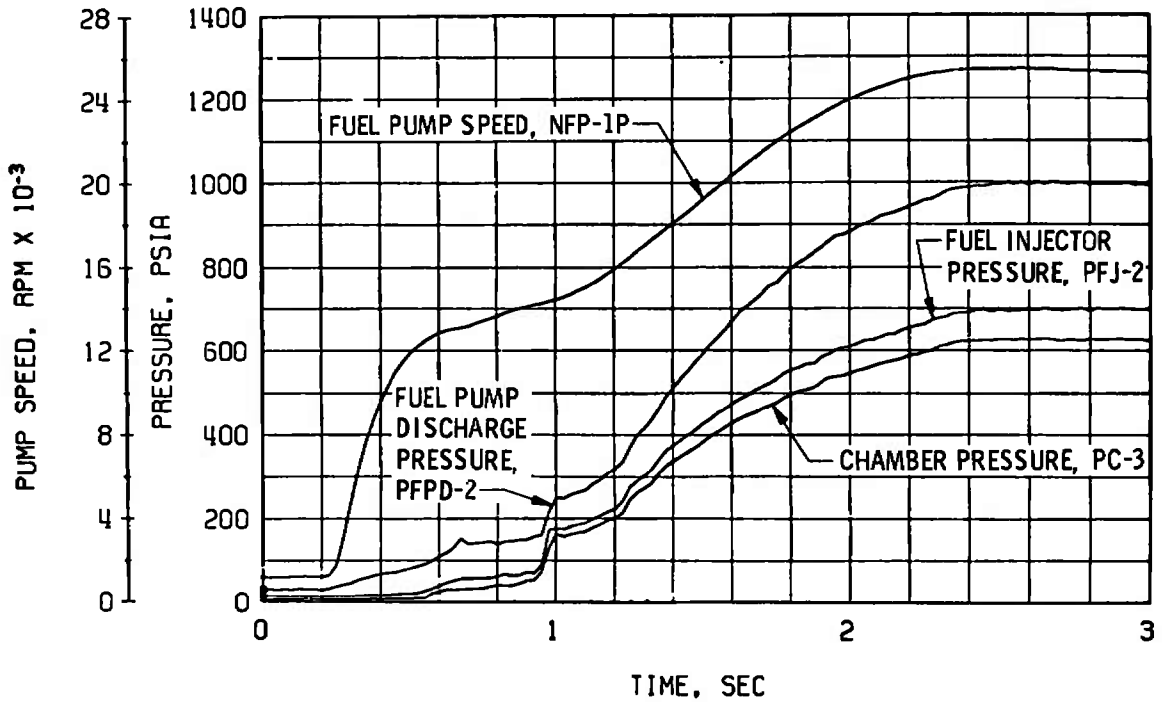

a. Thrust Chamber Fuel System, Start

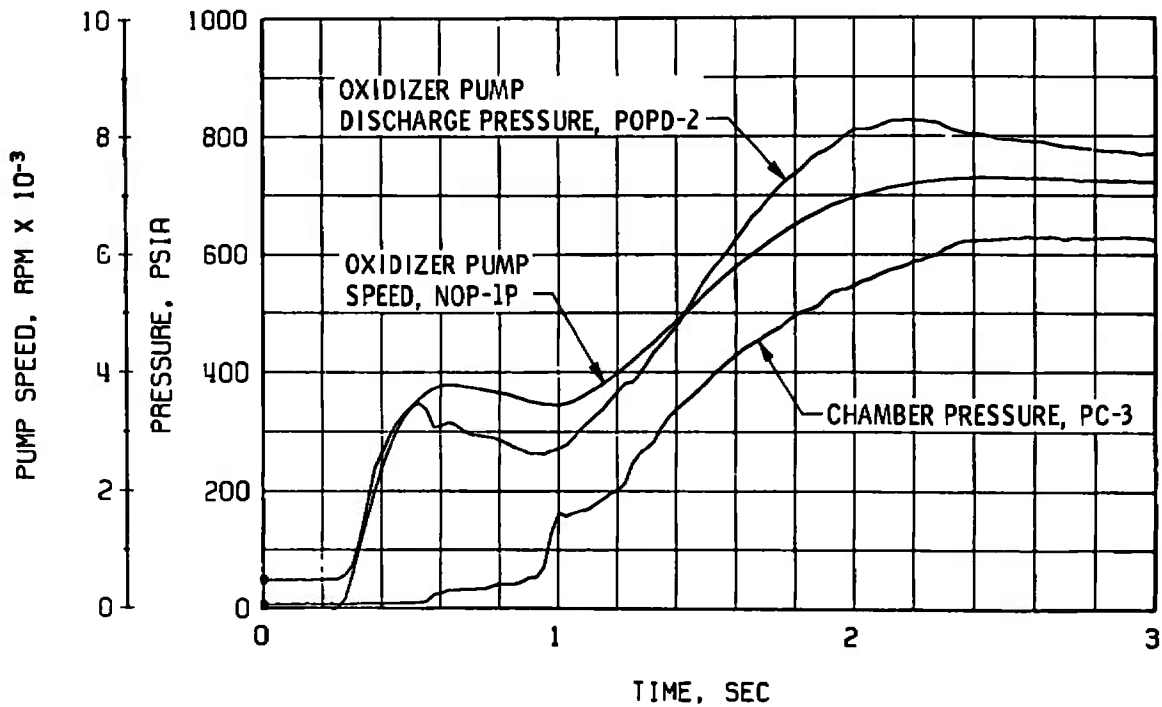

b. Thrust Chamber Oxidizer System, Start

Fig. 42 Engine Transient Operation, Firing 38D

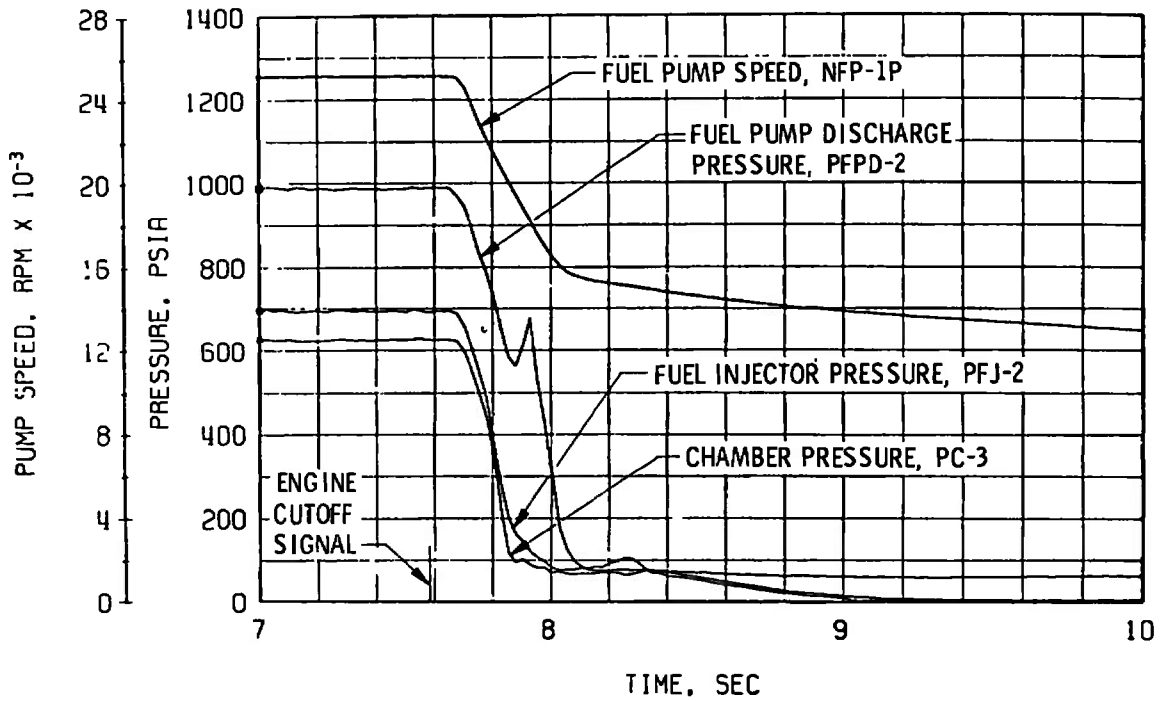

c. Thrust Chamber Fuel System, Shutdown

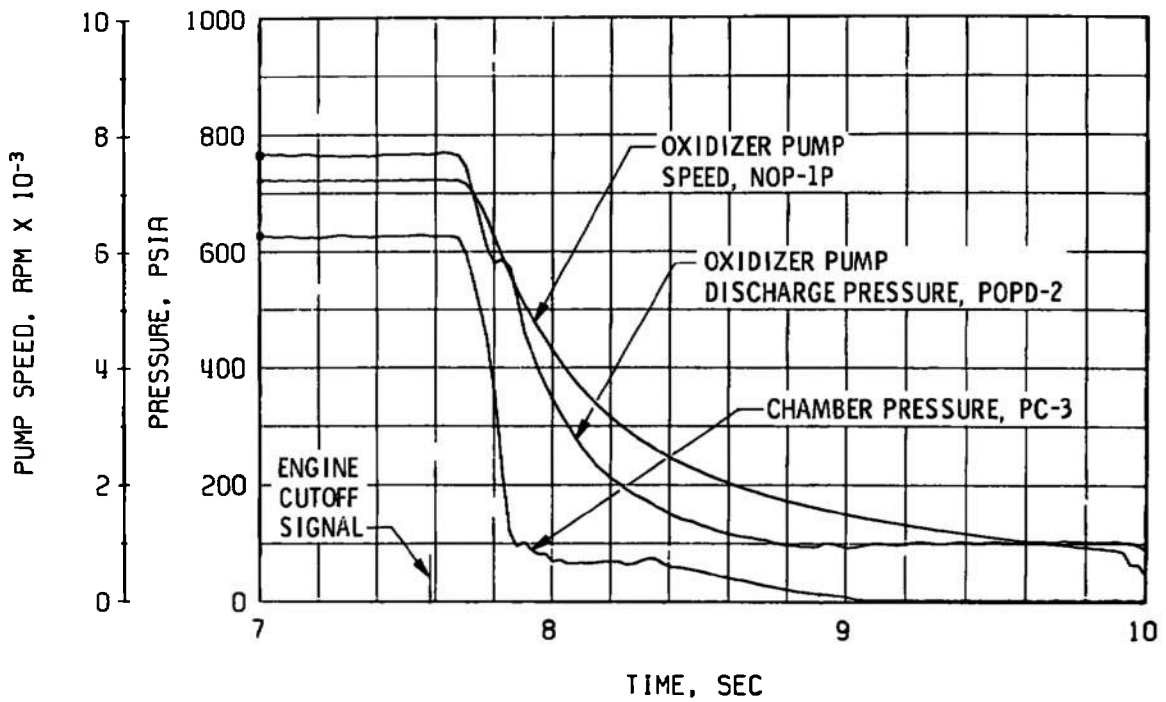

d. Thrust Chamber Oxidizer System, Shutdown

Fig. 42 Continued

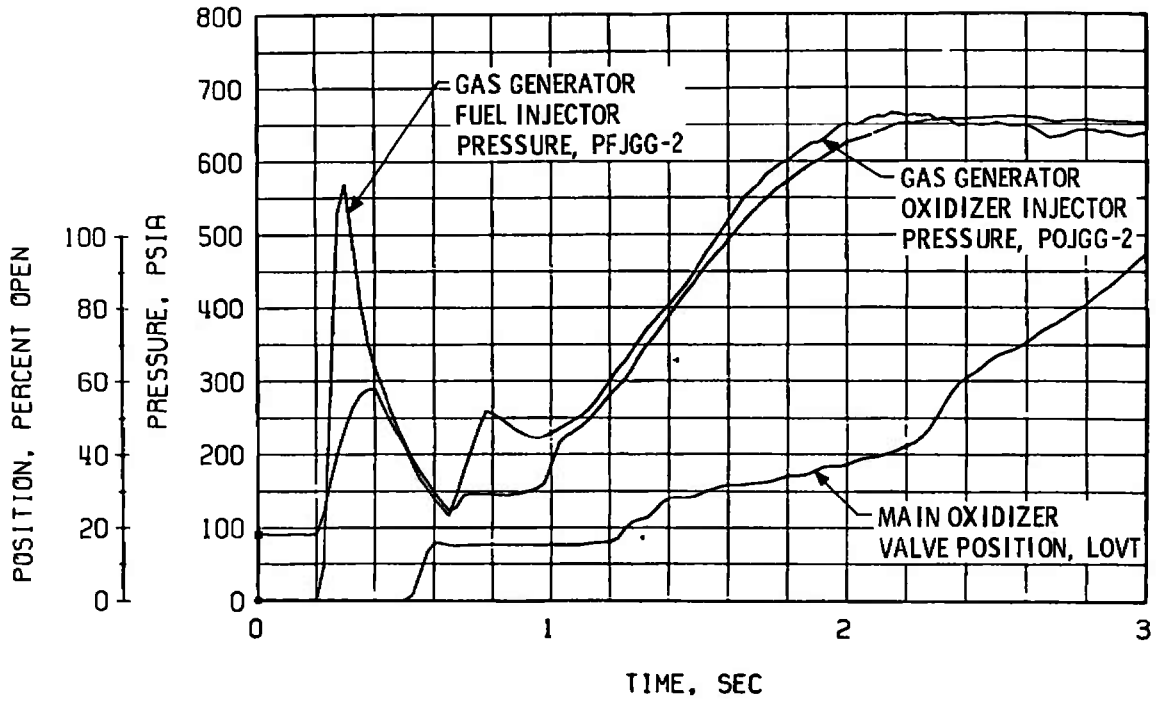

e. Gas Generator Injector Pressures and Main Oxidizer Valve Position, Start

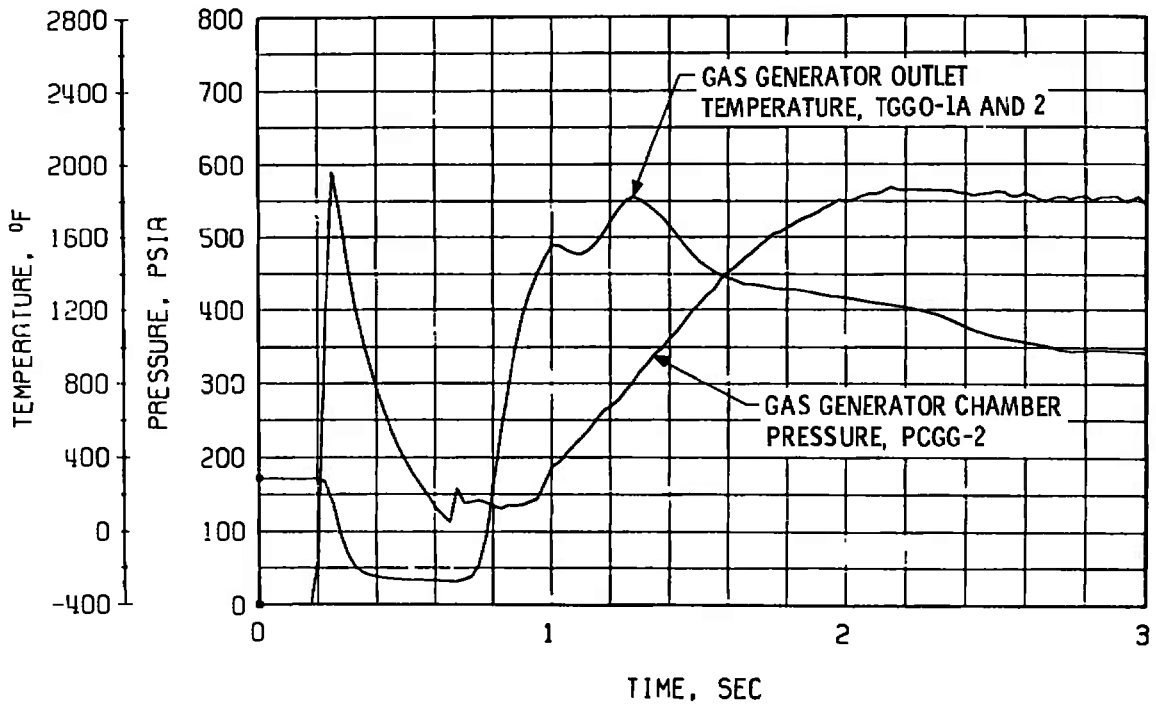

f. Gas Generator Chamber Pressure and Temperature, Start

Fig. 42 Continued

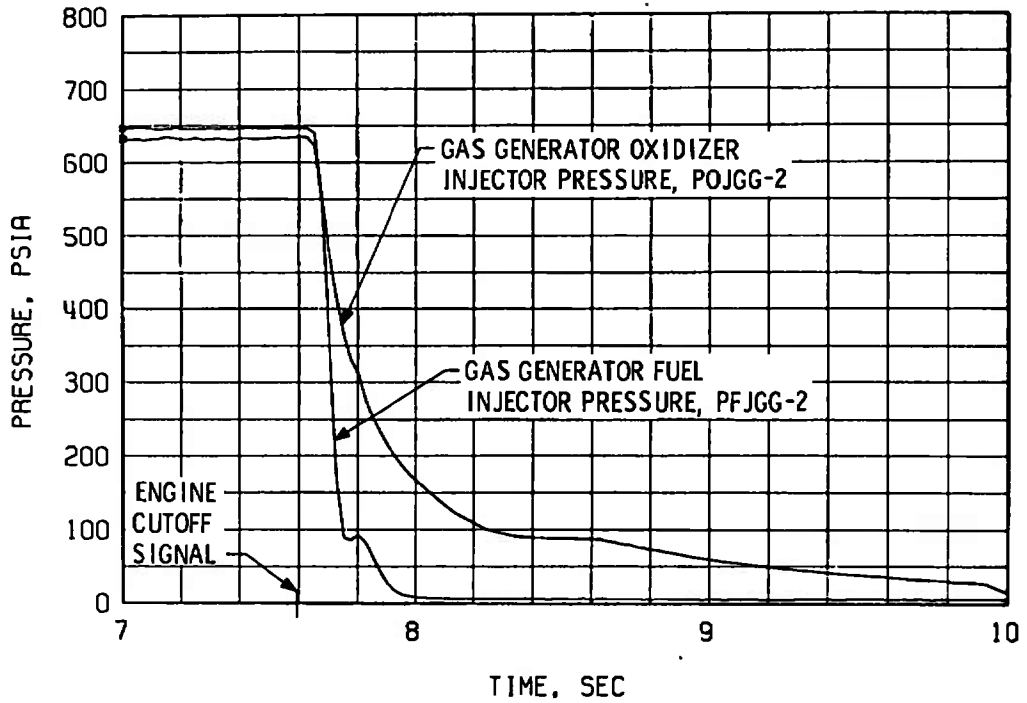

g. Gas Generator Injector Pressures, Shutdown

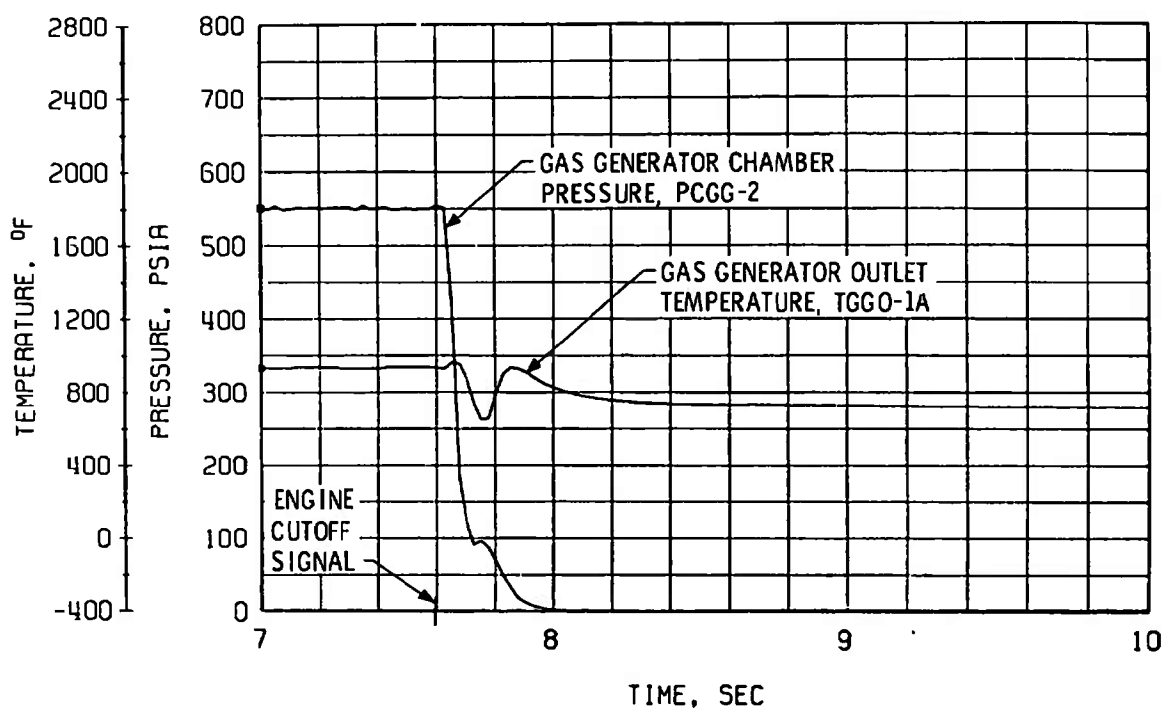

h. Gas Generator Chamber Pressure and Temperature, Shutdown

Fig. 42 Concluded

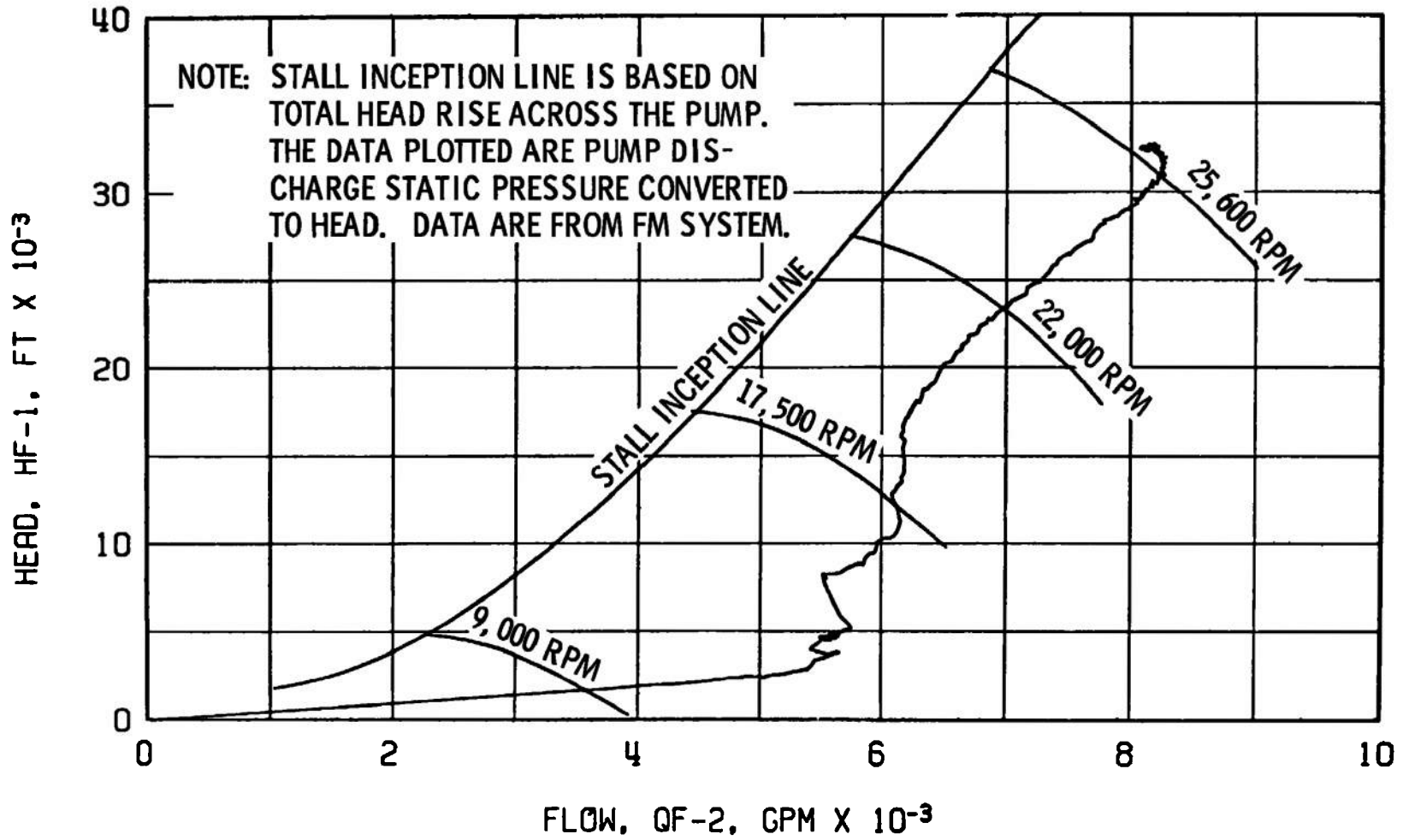

Fig. 43 Fuel Pump Start Transient Performance, Firing 38D

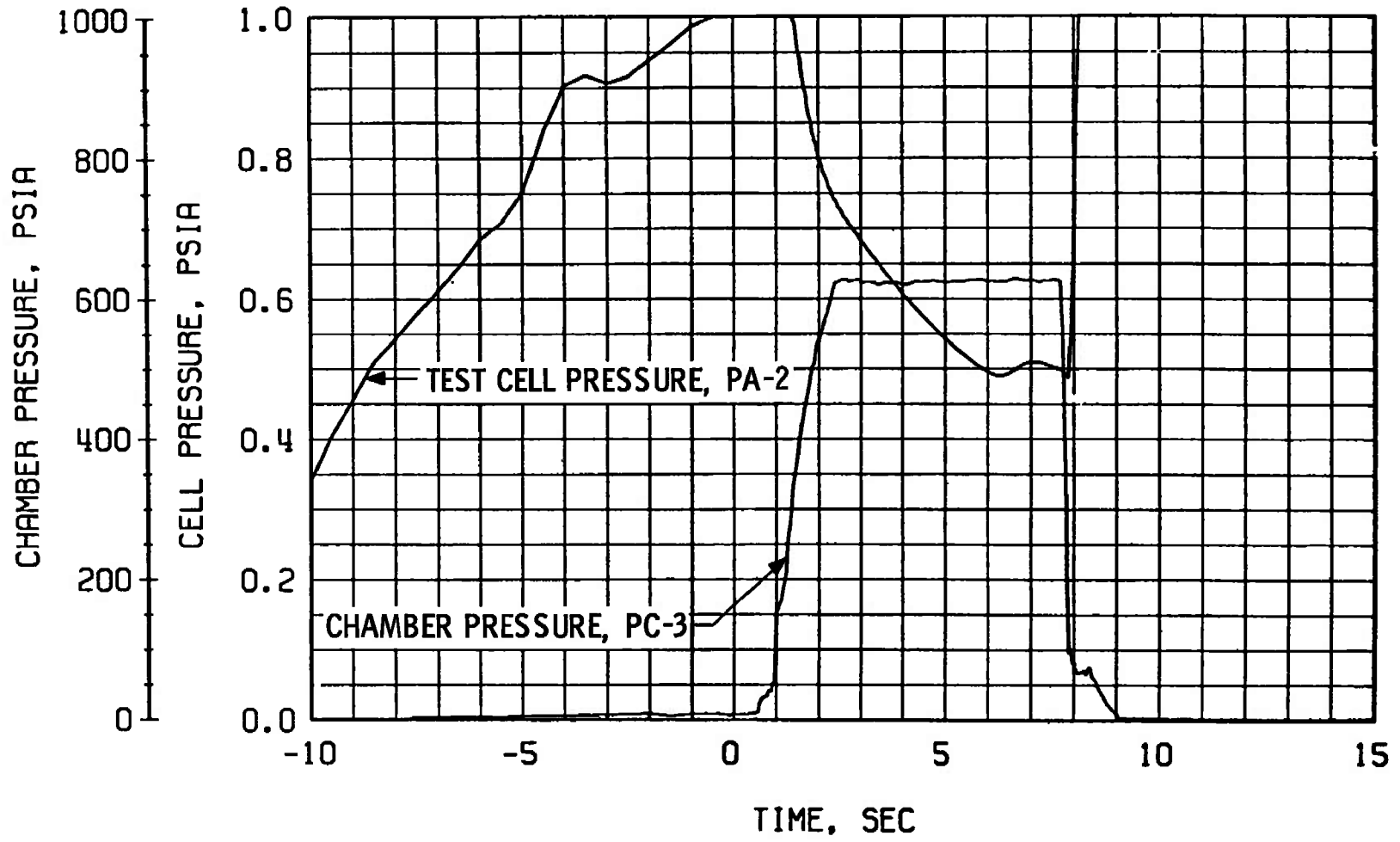
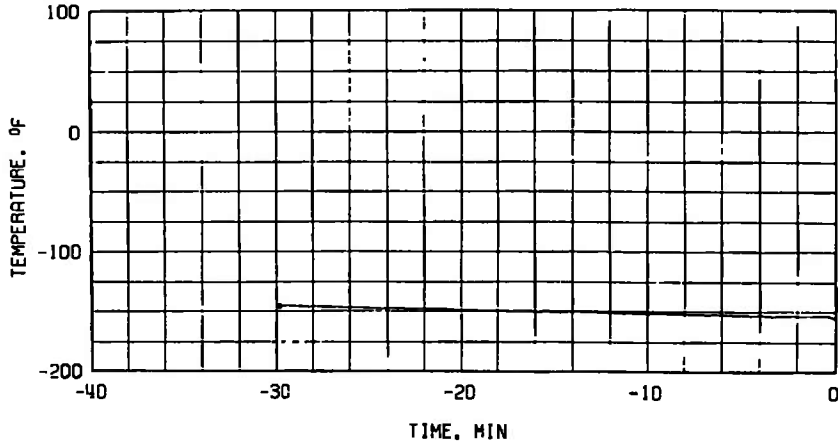
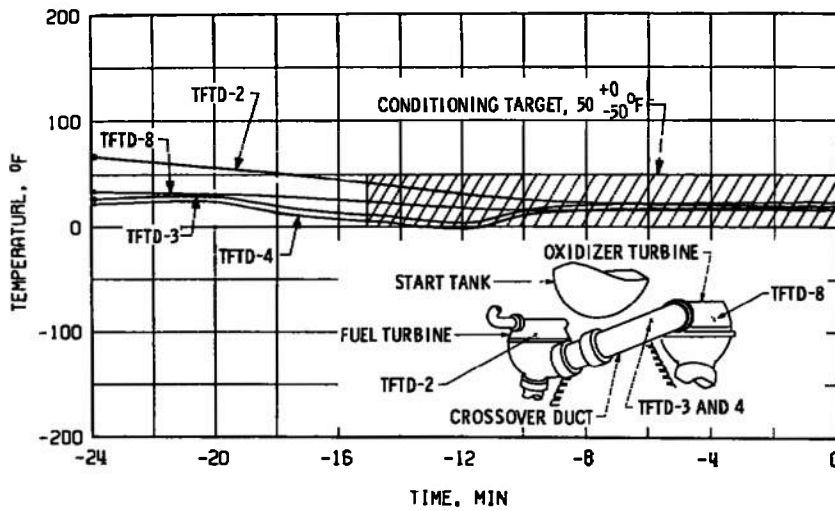

Fig. 44 Engine Ambient and Combustion Chamber Pressures, Firing 38D



a. Main Oxidizer Valve Second-Stage Actuator, TSOVC-1



b. Crossover Duct, TFTD

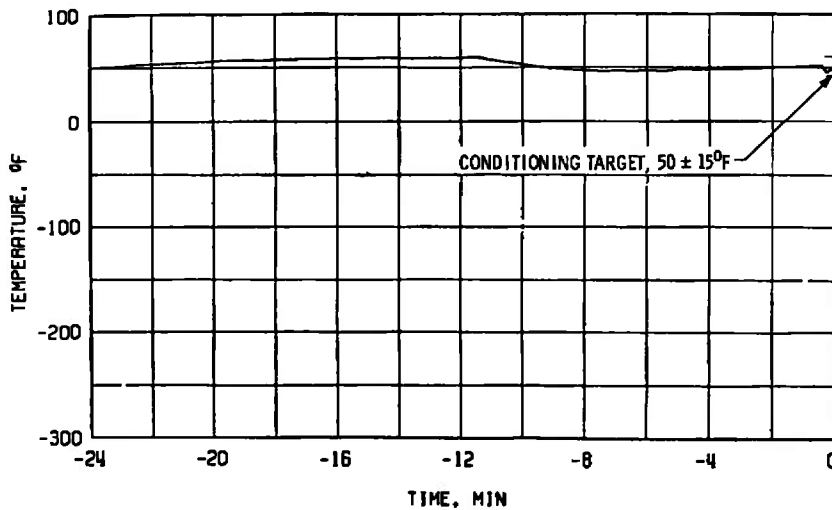

c. Thrust Chamber Throat, TTC-1P

Fig. 45 Thermal Conditioning History of Engine Components, Firing 38E

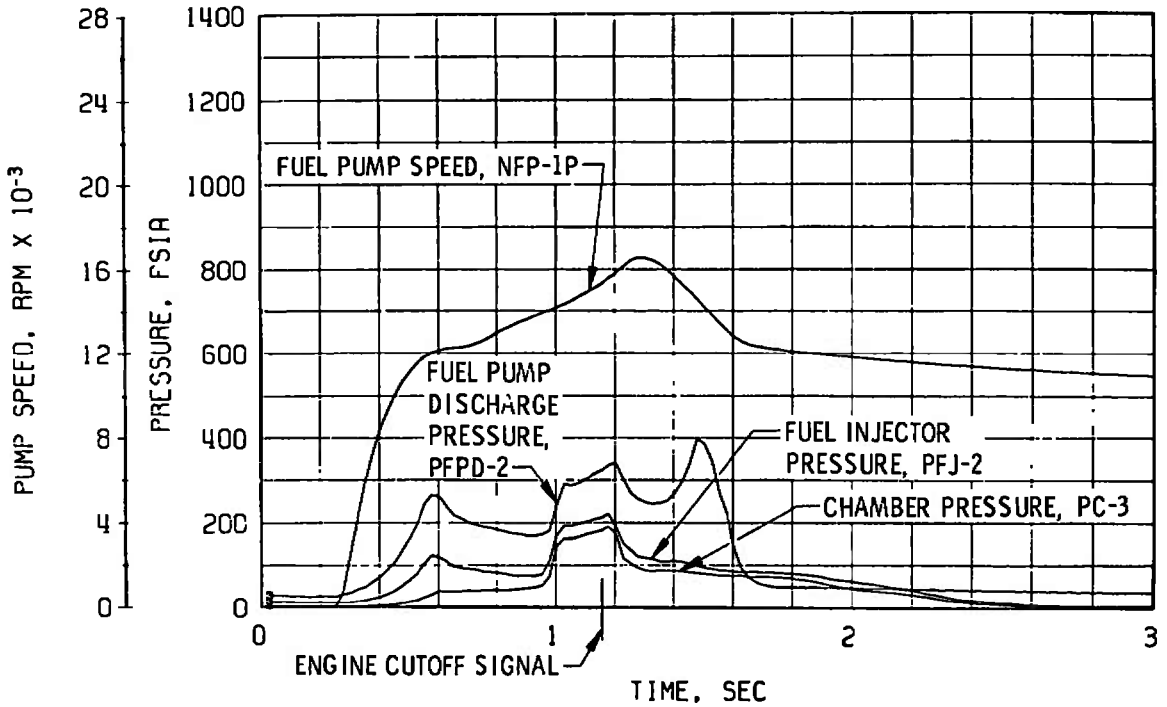

a. Thrust Chamber Fuel System, Start

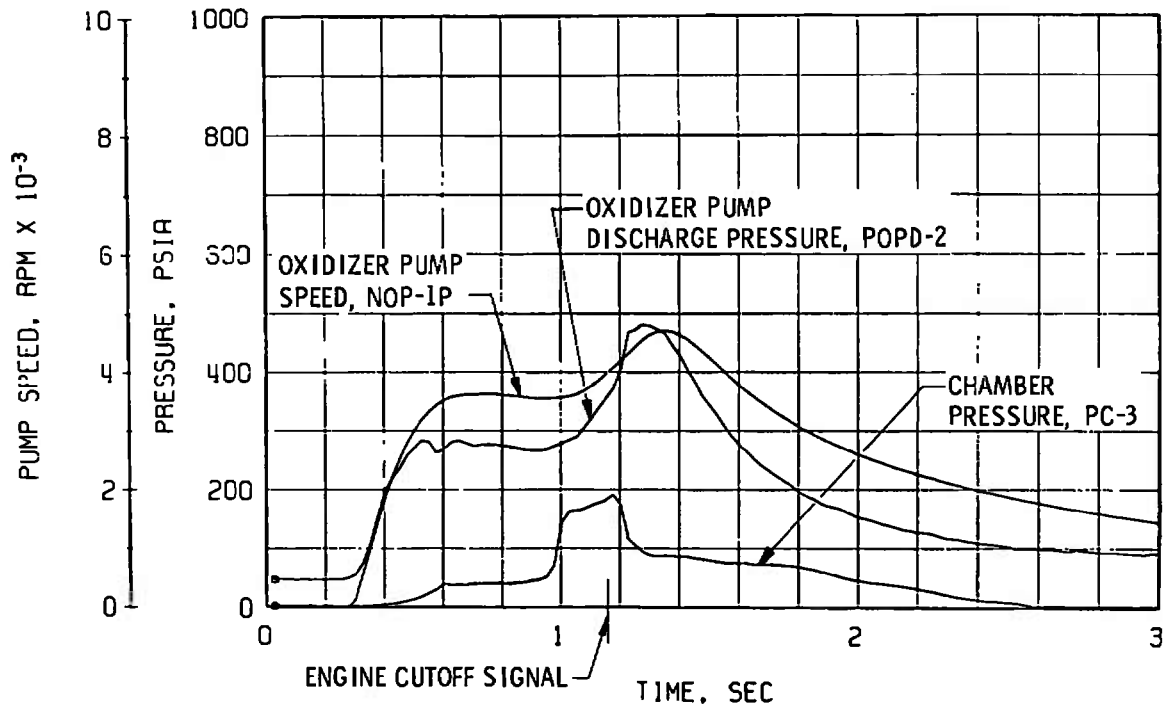

b. Thrust Chamber Oxidizer System, Start

Fig. 46 Engine Transient Operation, Firing 38E

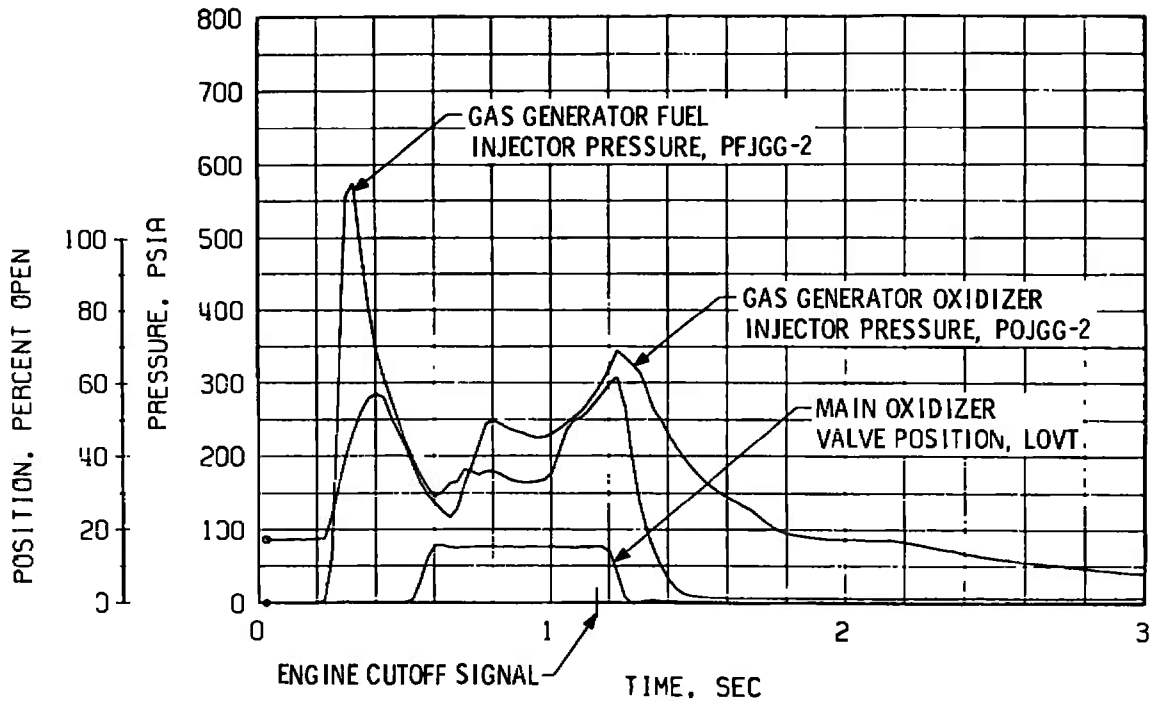

c. Gas Generator Injector Pressures and Main Oxidizer Valve Position, Start

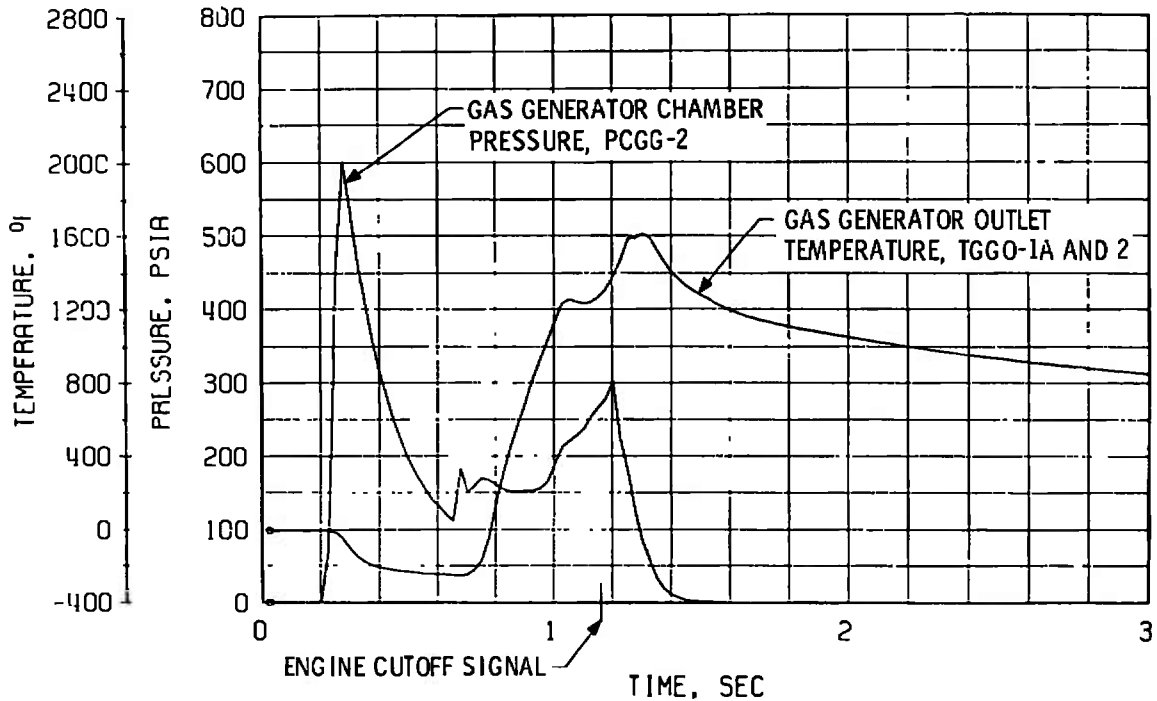

d. Gas Generator Chamber Pressure and Temperature, Start

Fig. 46 Concluded

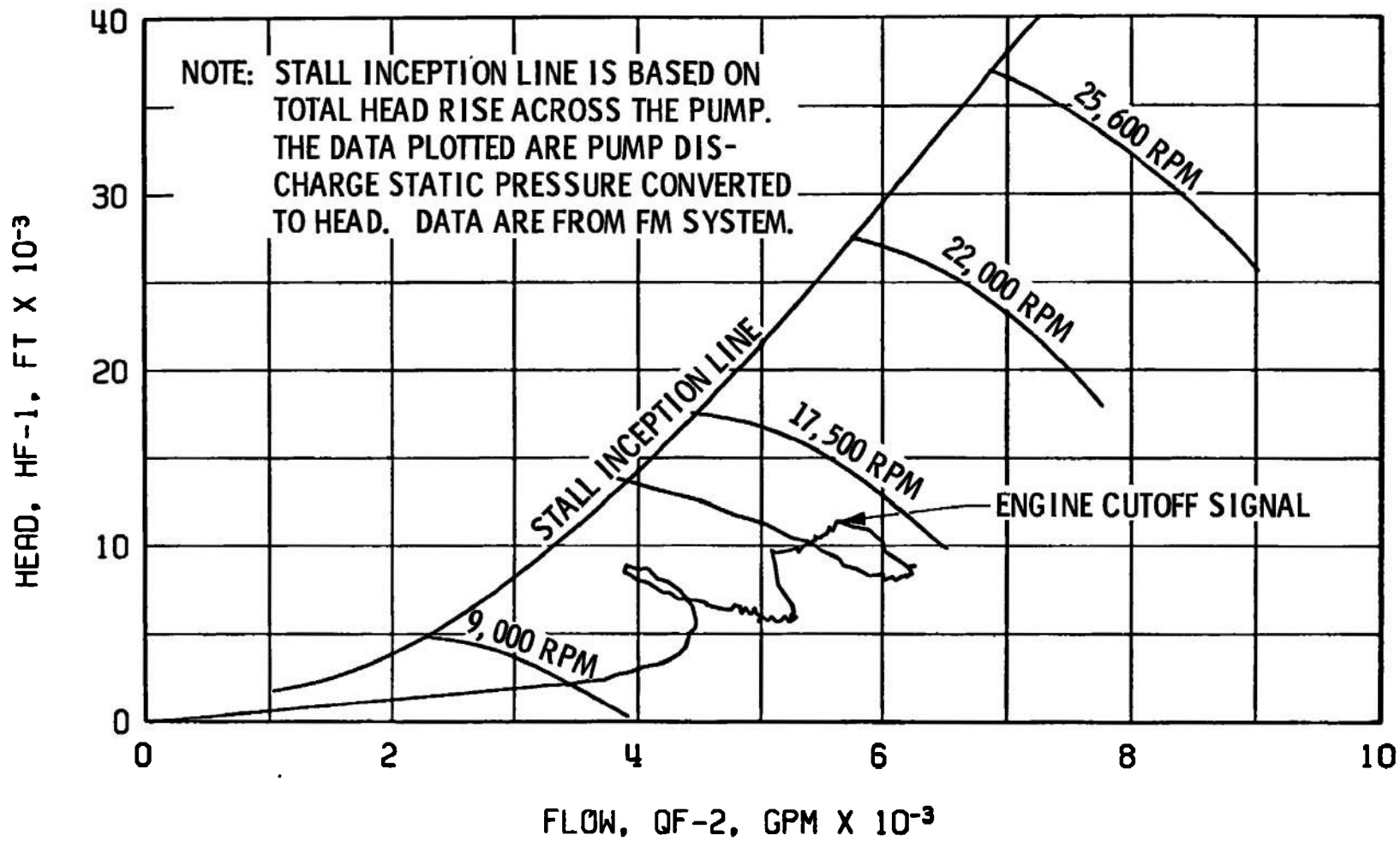

Fig. 47 Fuel Pump Start Transient Performance, Firing 38E

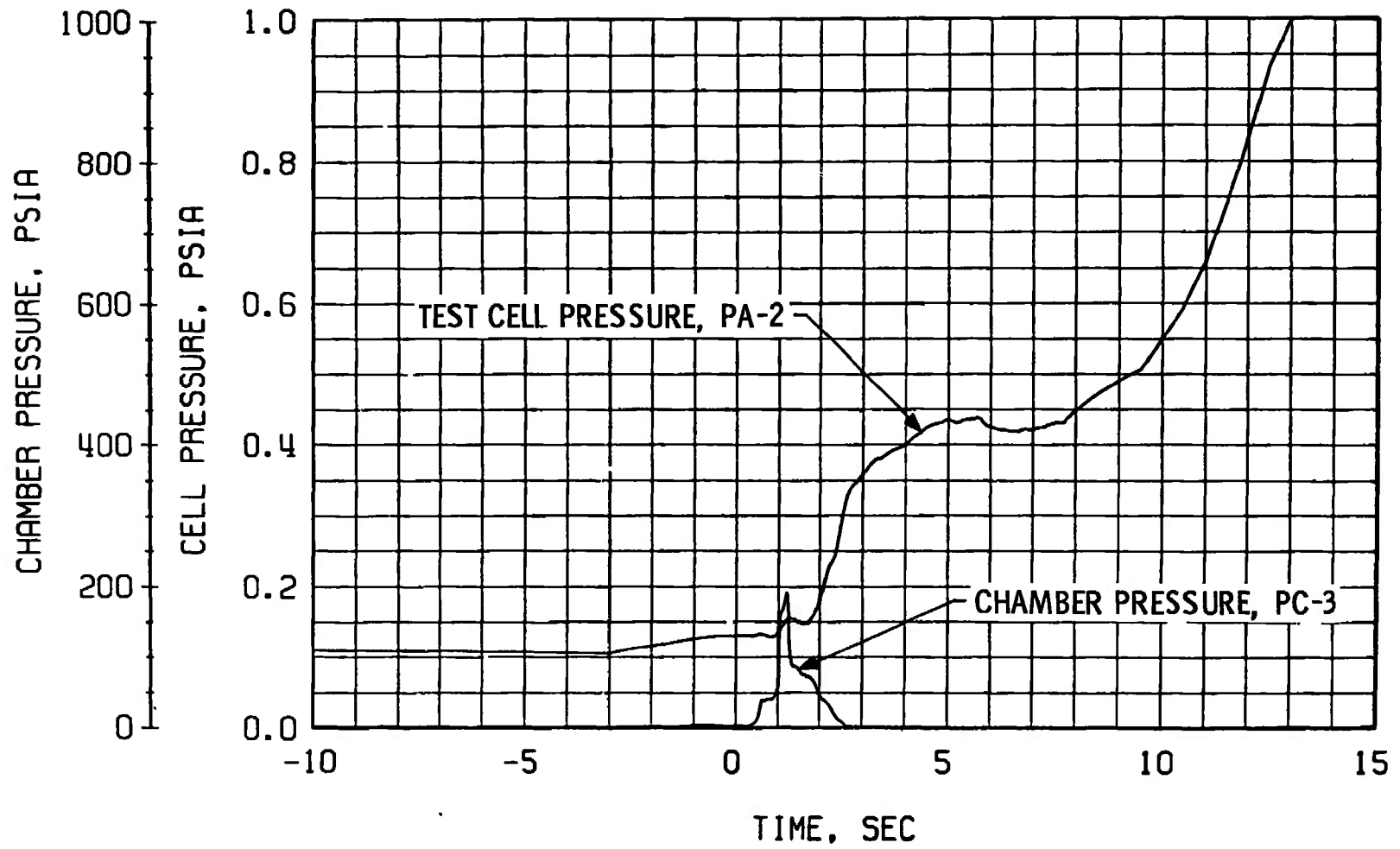

Fig. 48 Engine Ambient and Combustion Chamber Pressures, Firing 38E

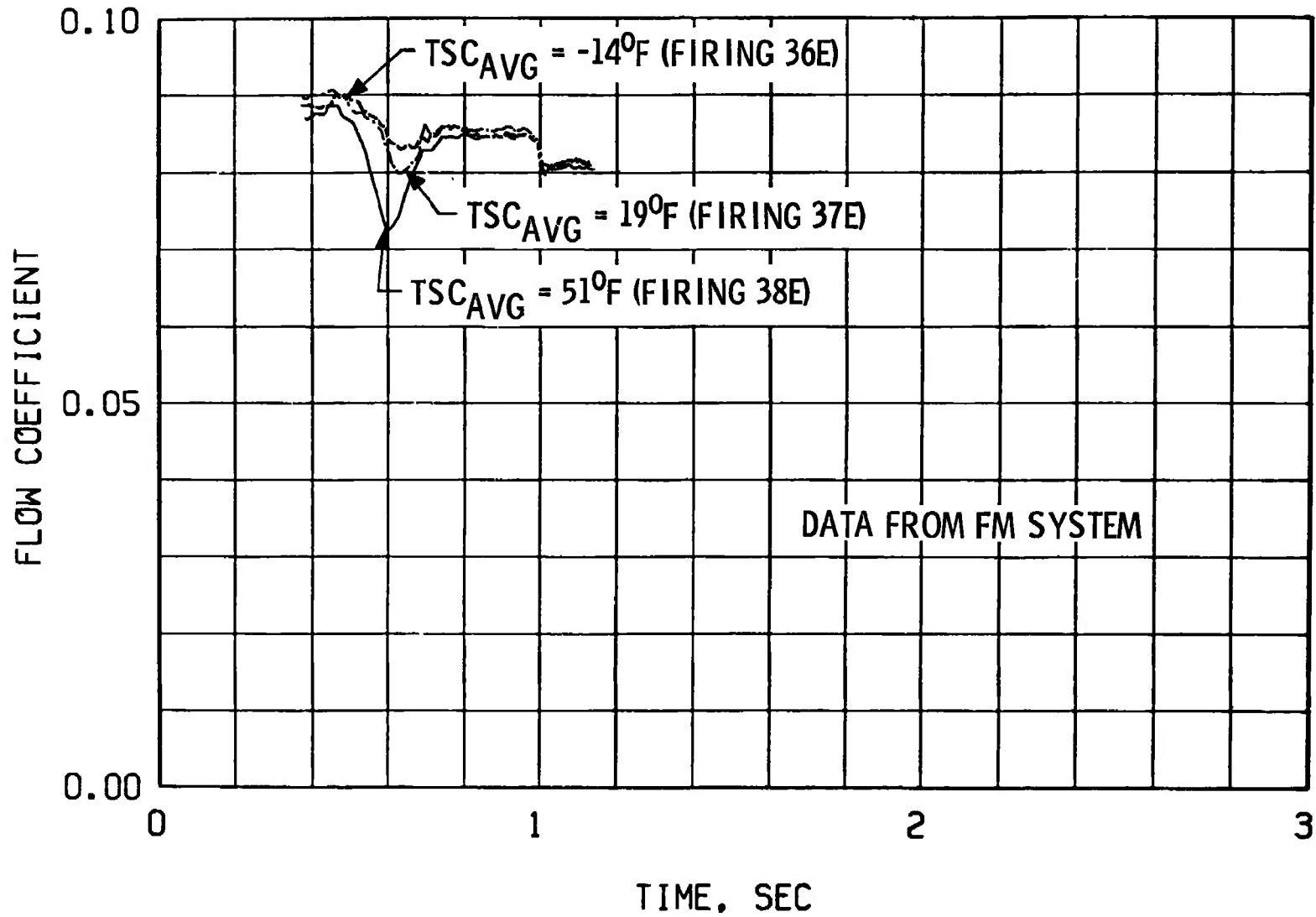

Fig. 49 Thrust Chamber Temperature Conditioning Effects on Fuel Pump Flow Coefficient, Firings 36E, 37E, and 38E

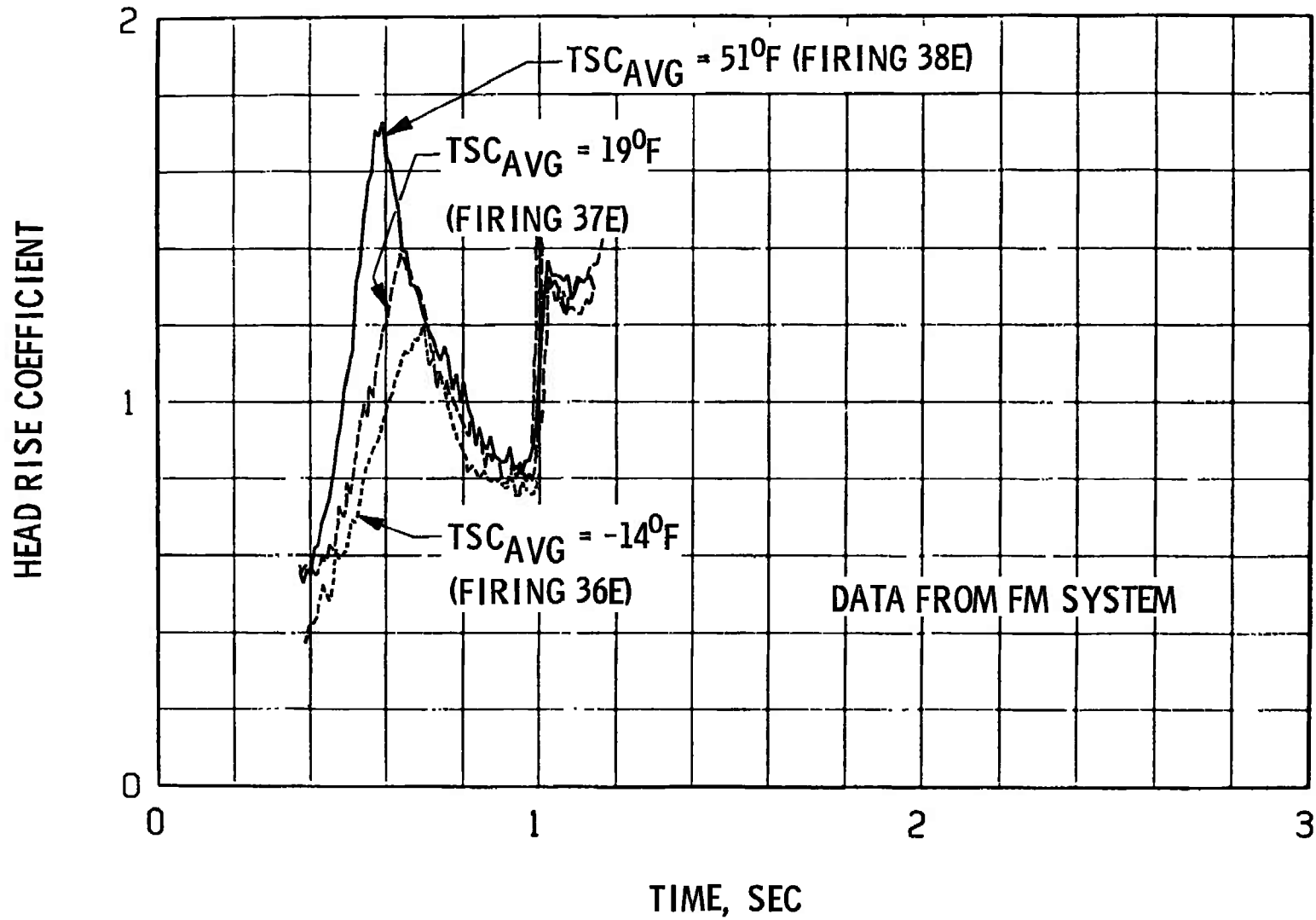
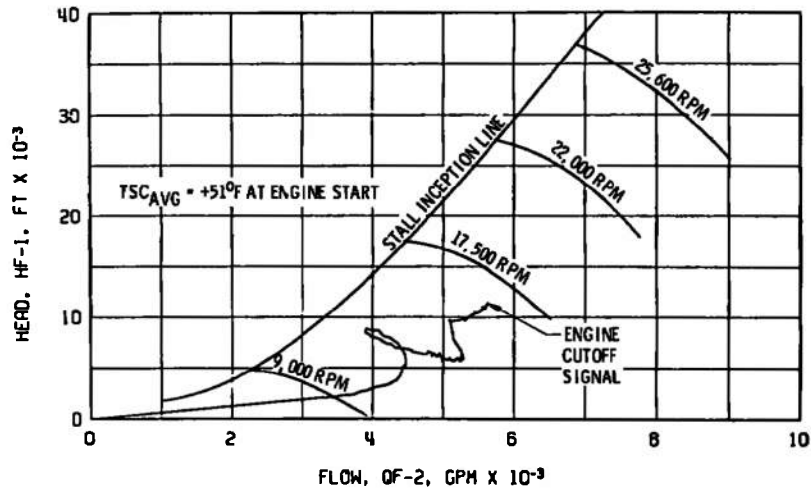
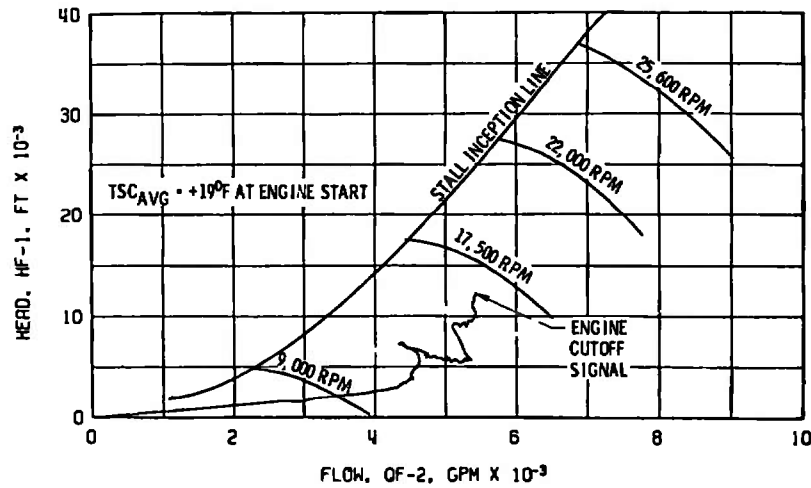

Fig. 50 Thrust Chamber Temperature Conditioning Effects on Fuel Pump Head Rise Coefficient, Firings 36E, 37E, and 38E



a. Firing 38E



b. Firing 37E

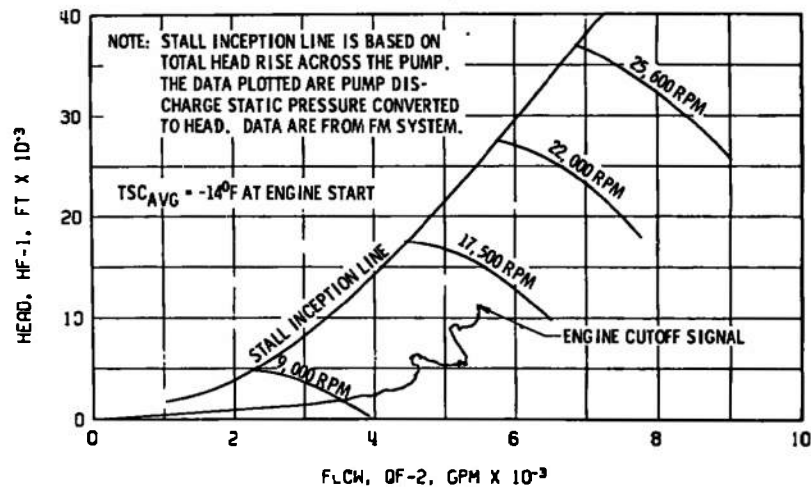

c. Firing 36E

Fig. 51 Thrust Chamber Temperature Conditioning Effects on Fuel Pump Start Transient Performance, Firings 36E, 37E, and 38E

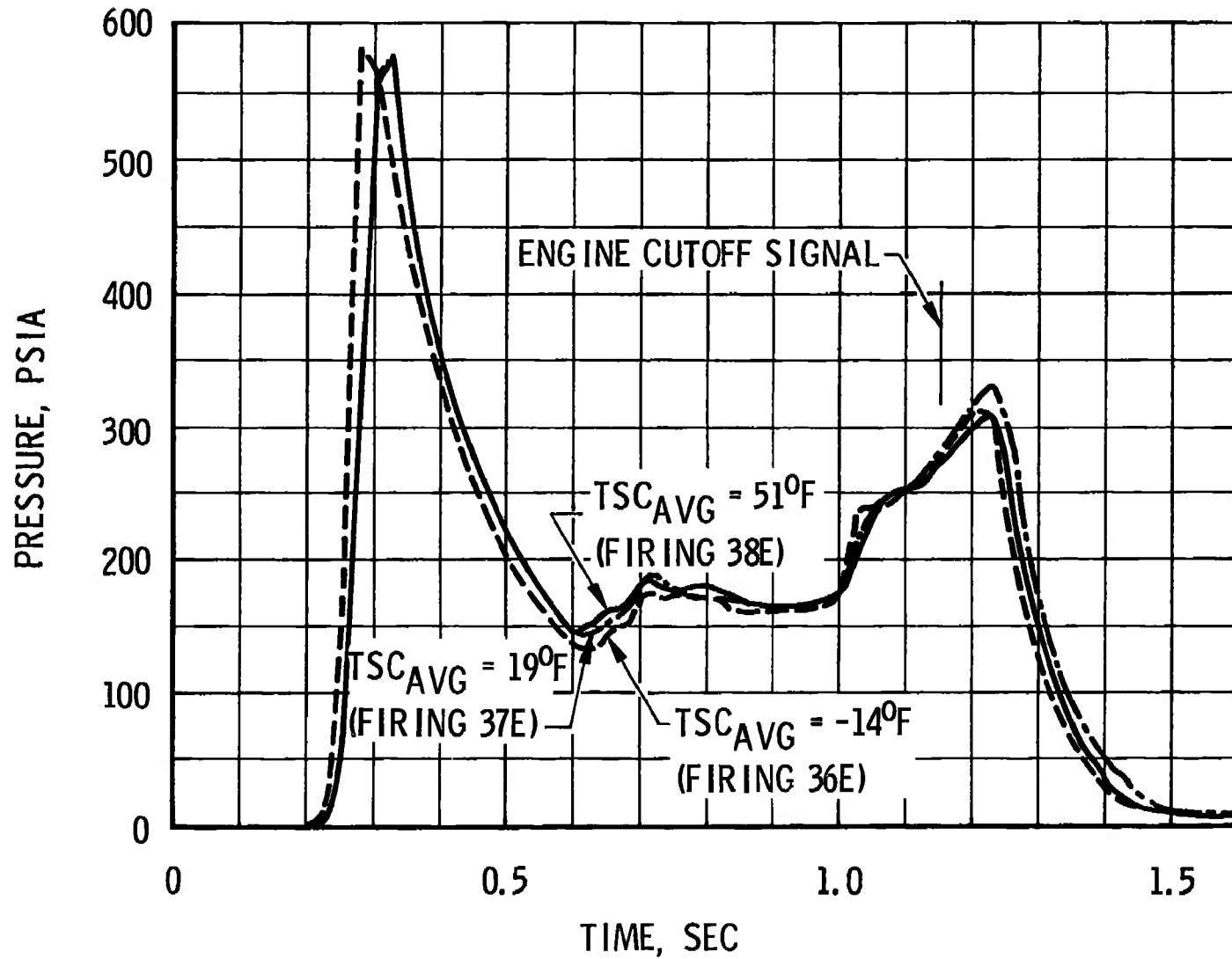

Fig. 52 Thrust Chamber Temperature Conditioning Effects on Gas Generator
Fuel Injector Pressure, Firings 36E, 37E, and 38E

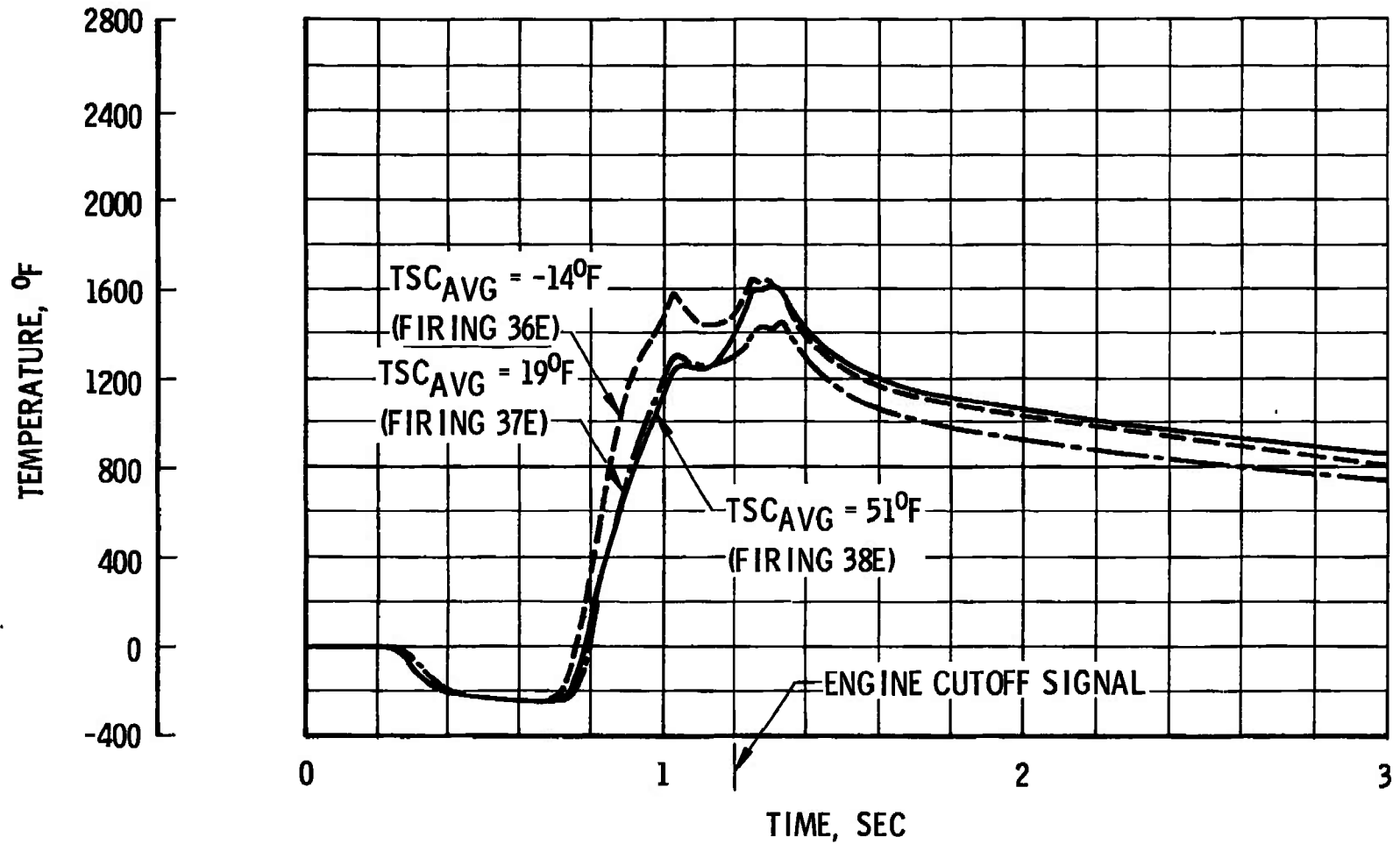

Fig. 53 Thrust Chamber Temperature Conditioning Effects on Gas Generator Outlet Temperature Transient, Firings 36E, 37E, and 38E

100

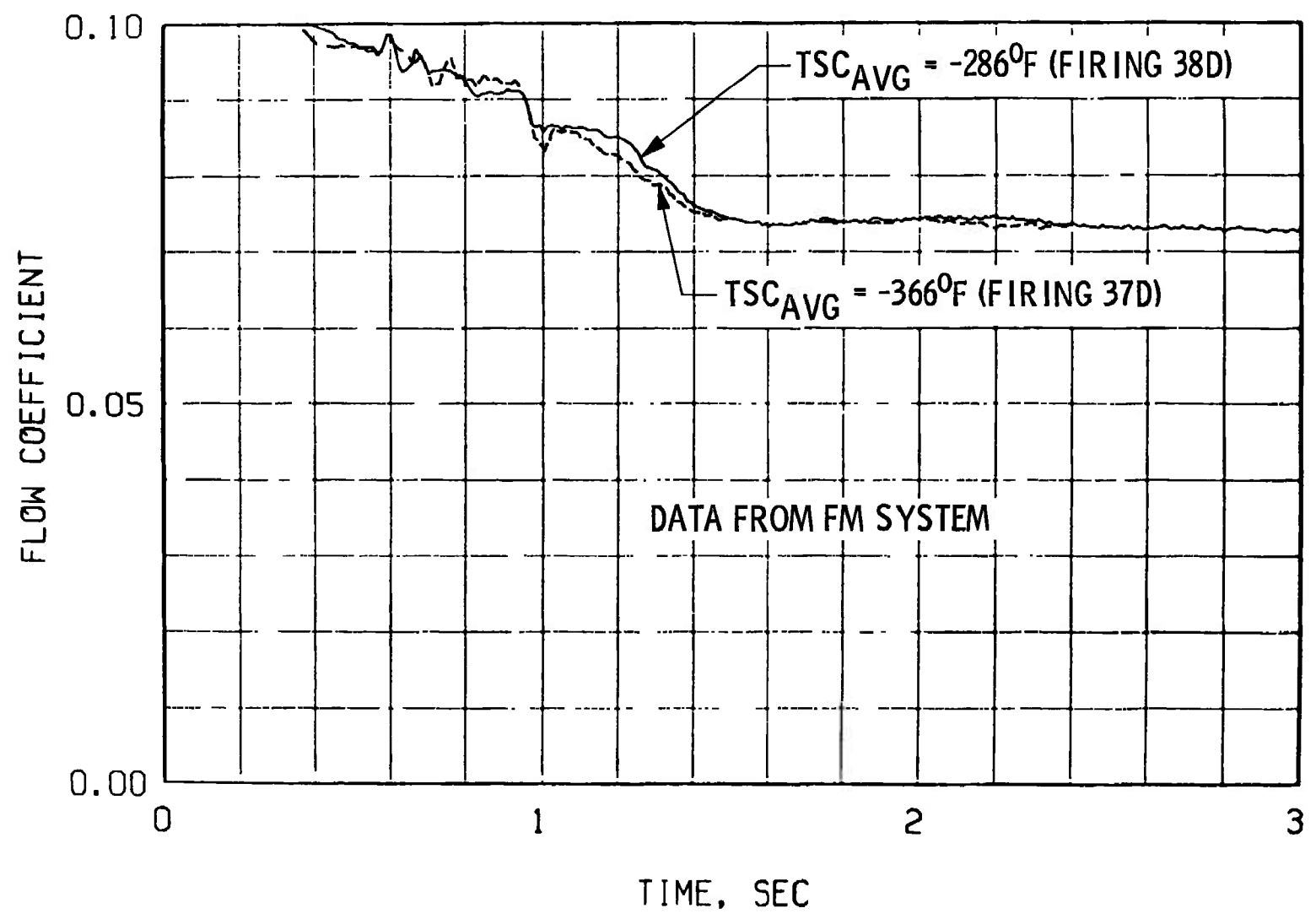

Fig. 54 Thrust Chamber Temperature Conditioning Effects on Fuel Pump Flow Coefficient, Firings 37D and 38D

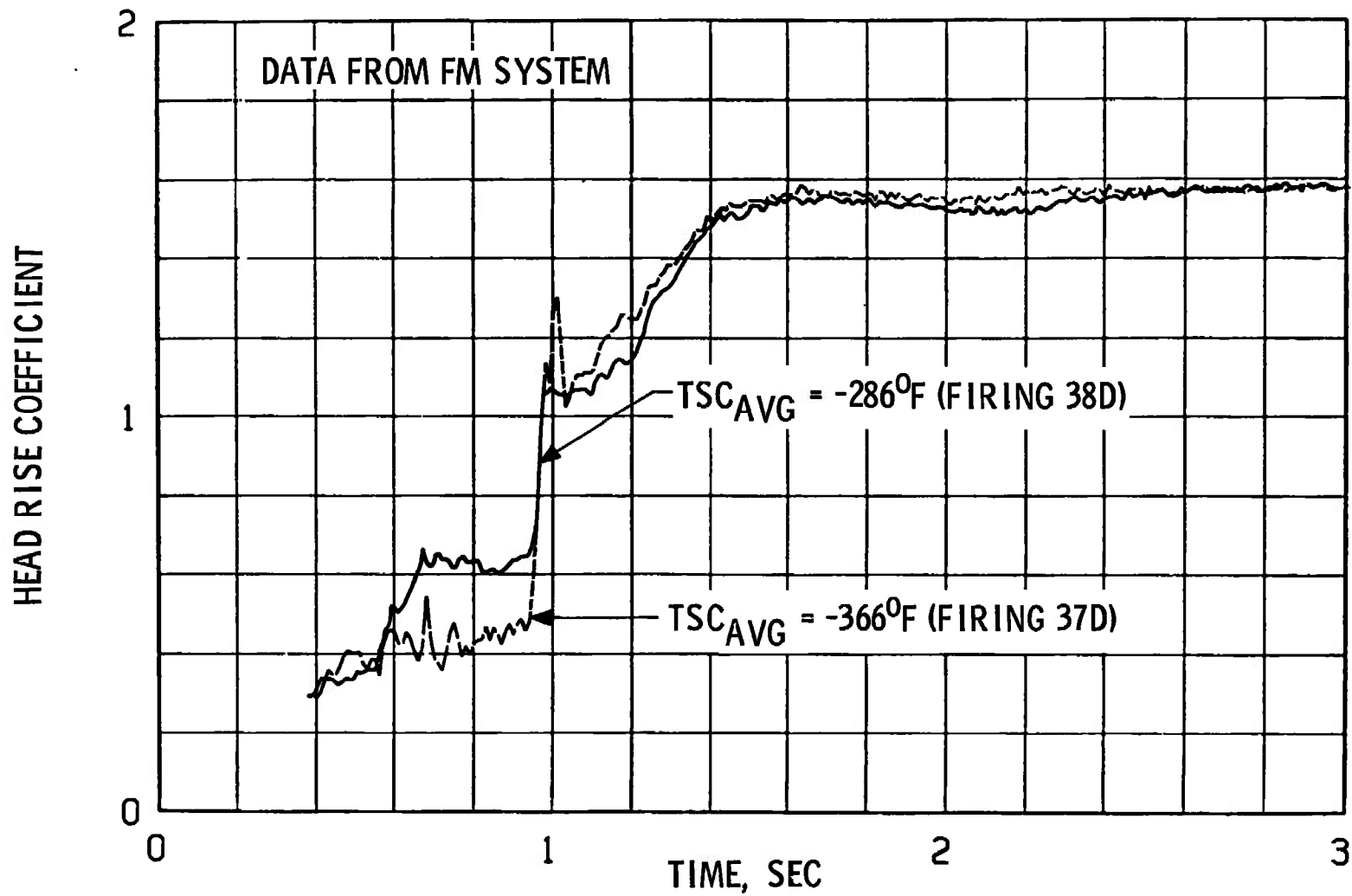

Fig. 55 Thrust Chamber Temperature Conditioning Effects of Fuel Pump Head Rise Coefficient, Firings 37D and 38D

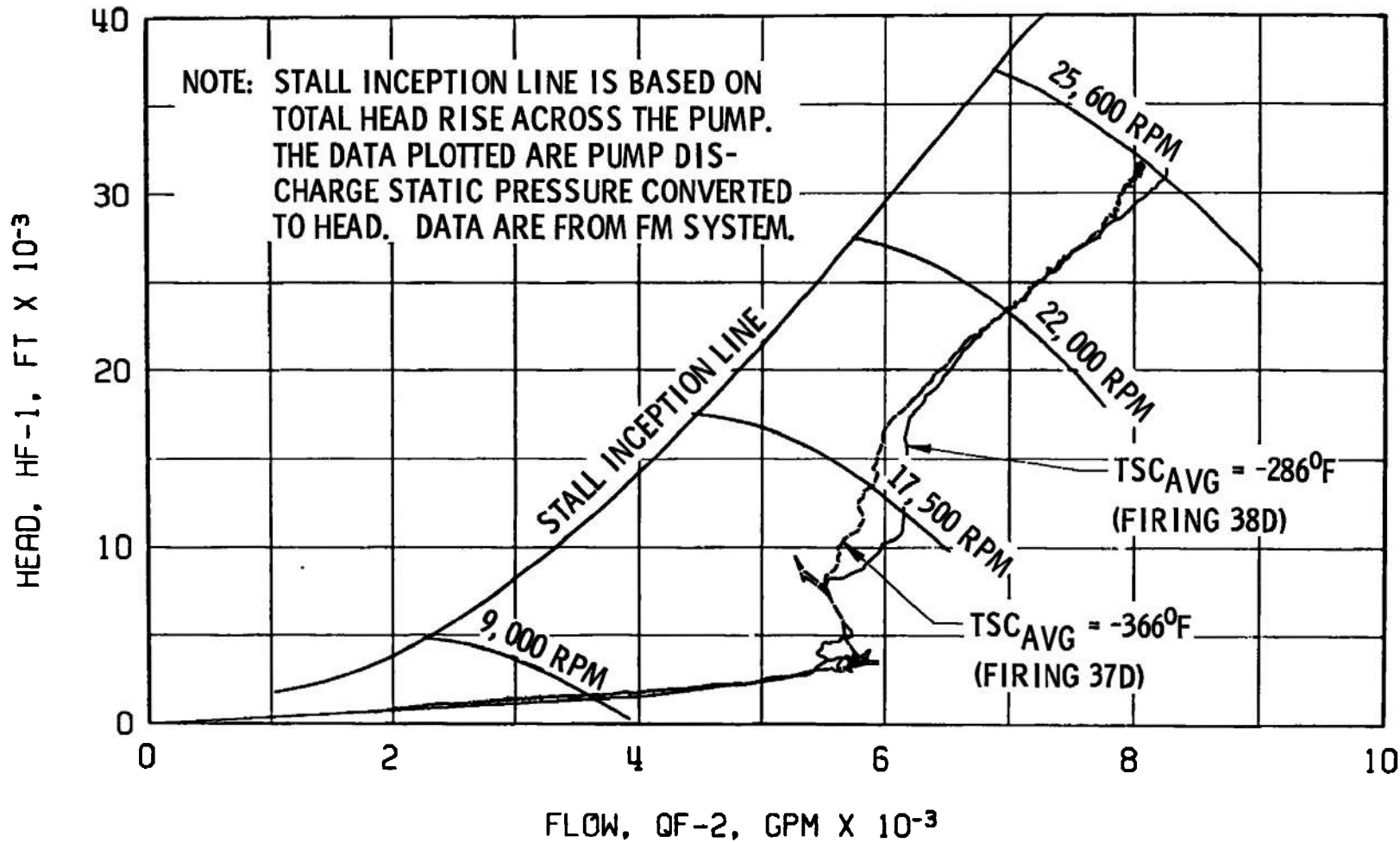

Fig. 56 Thrust Chamber Temperature Conditioning Effects on Fuel Pump Start Transient Performance, Firings 37D and 38D

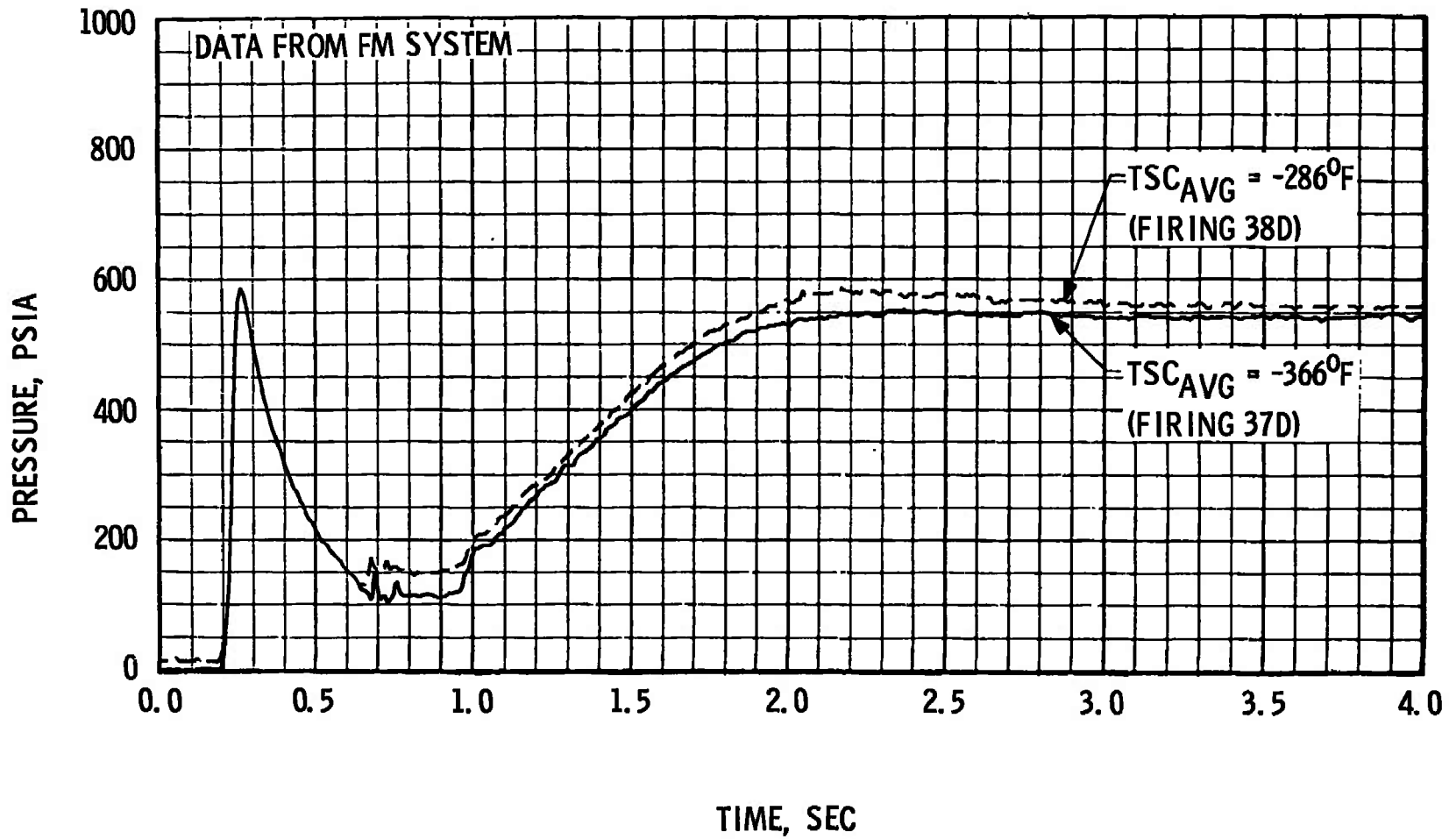

Fig. 57 Thrust Chamber Temperature Conditioning Effects on Gas Generator Chamber Pressure Transients, Firings 37D and 38D

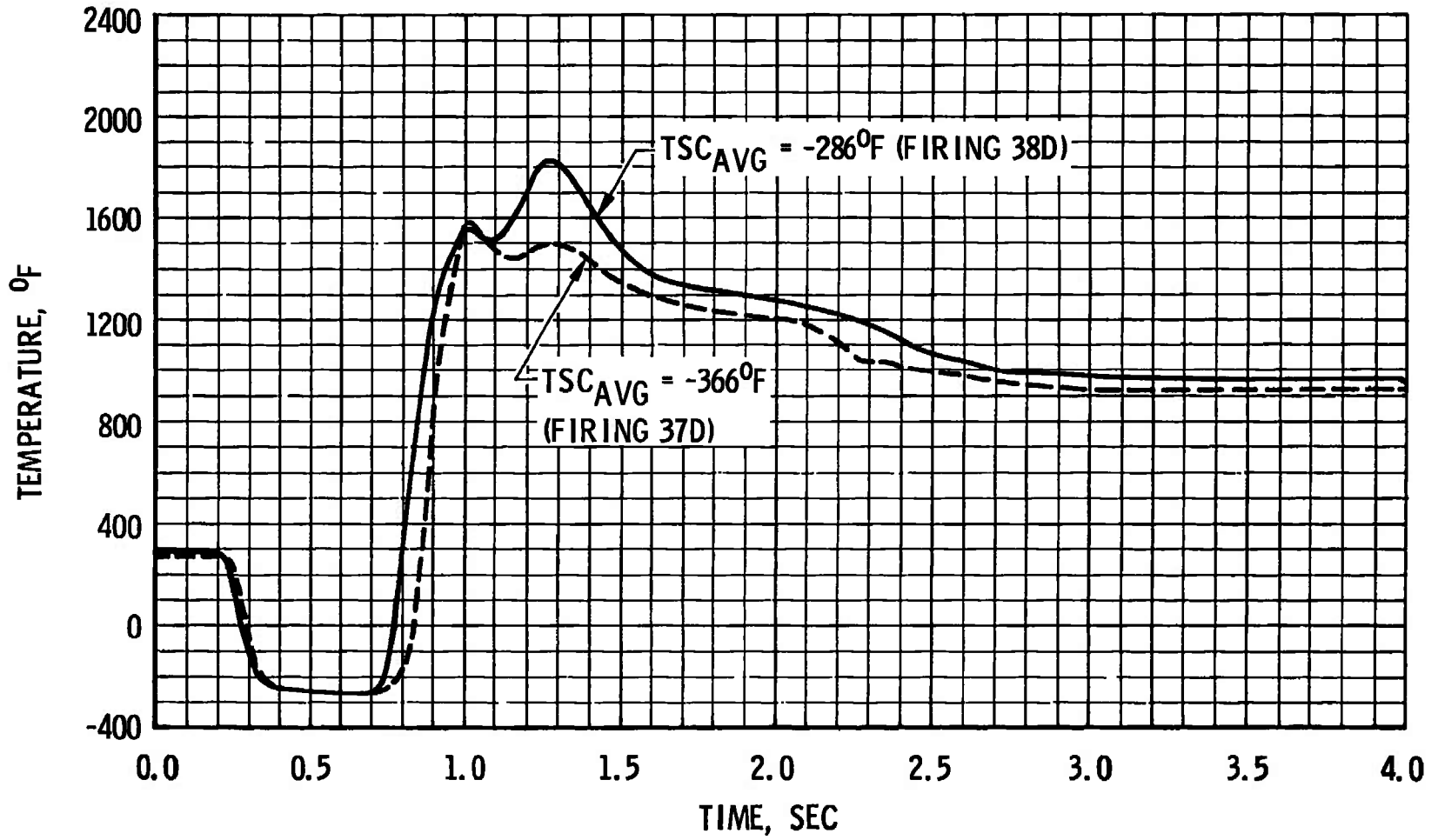

Fig. 58 Thrust Chamber Temperature Conditioning Effects on Gas Generator Outlet Temperature Transient, Firings 37D and 38D

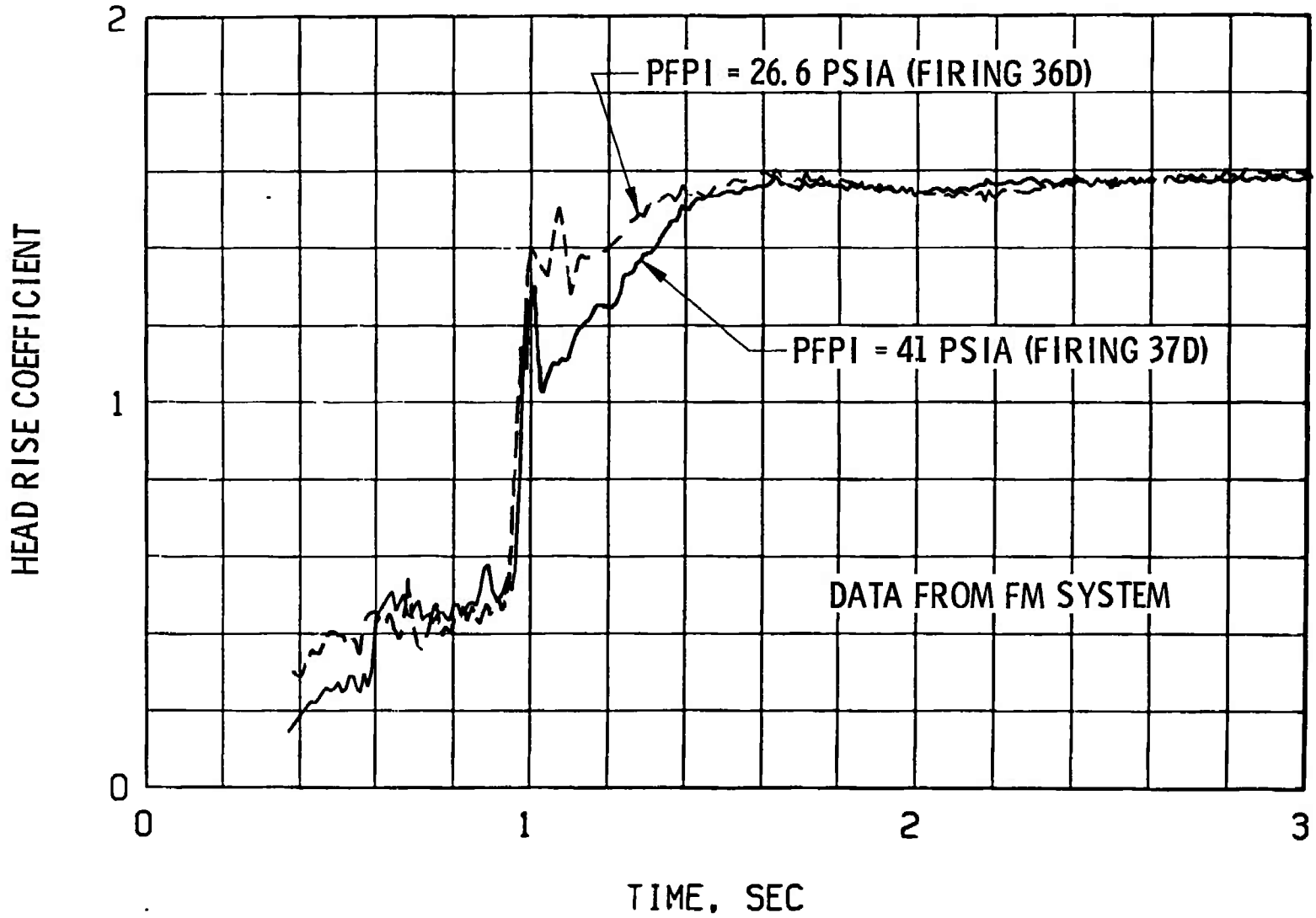

Fig. 59 Fuel Pump Inlet Pressure Effect on Fuel Pump Head Rise Coefficient, Firings 36D and 37D

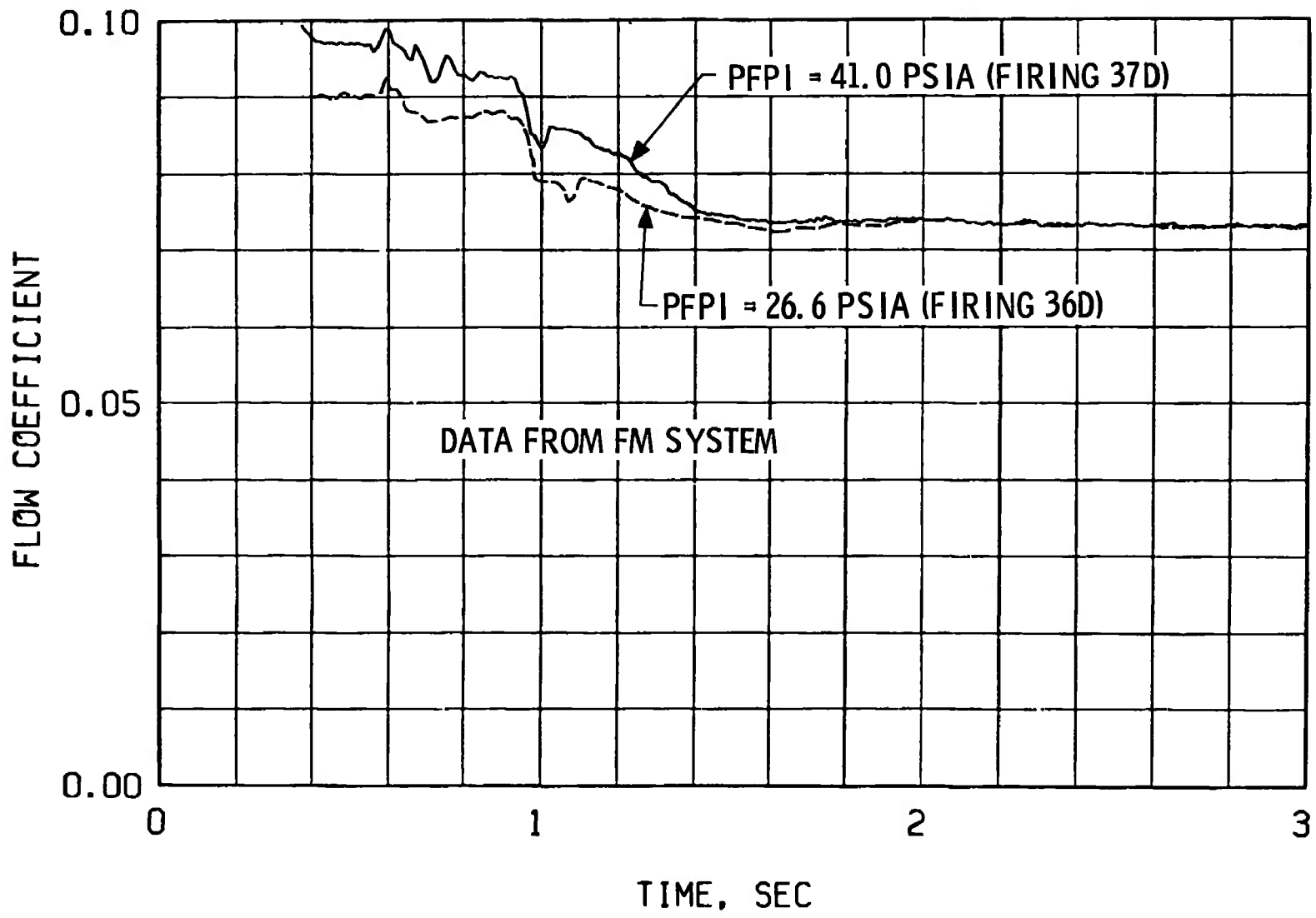

Fig. 60 Fuel Pump Inlet Pressure Effect on Fuel Pump Flow Coefficient, Firings 36D and 37D

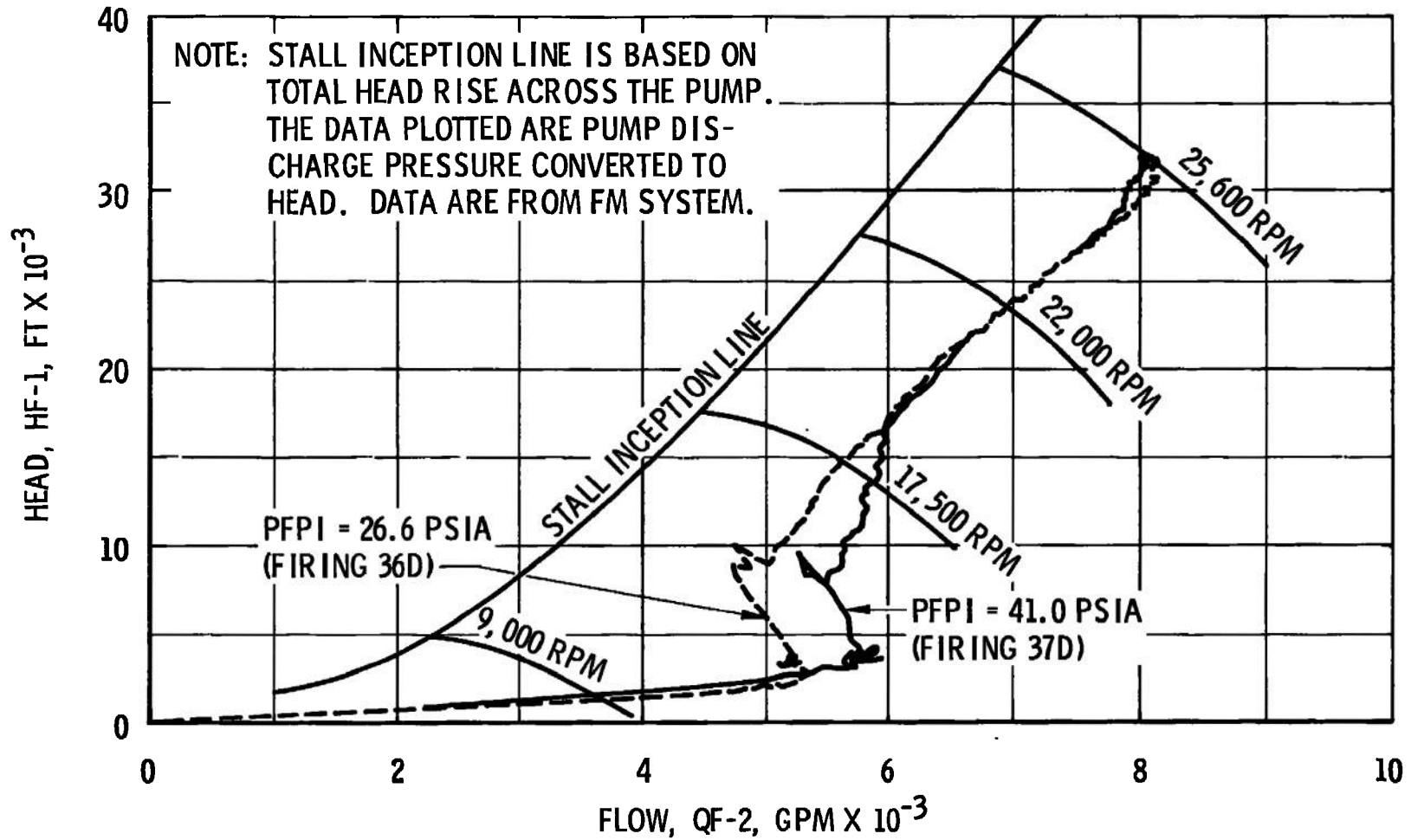

Fig. 61 Fuel Pump Inlet Pressure Effect on Fuel Pump Start Transient Performance, Firings 36D and 37D

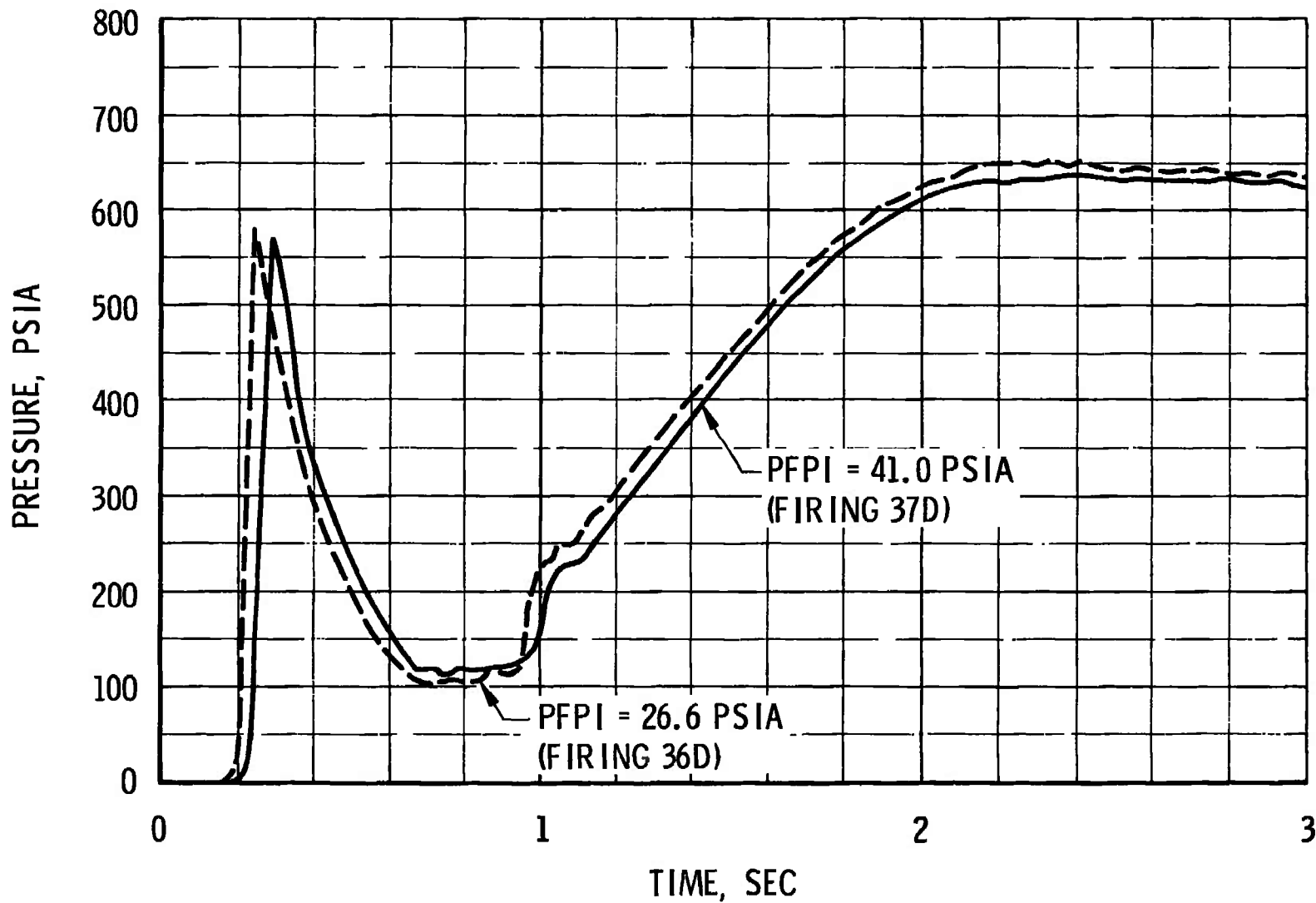

Fig. 62 Fuel Pump Inlet Pressure Effect on Gas Generator Fuel
Injector Pressure, Firings 36D and 37D

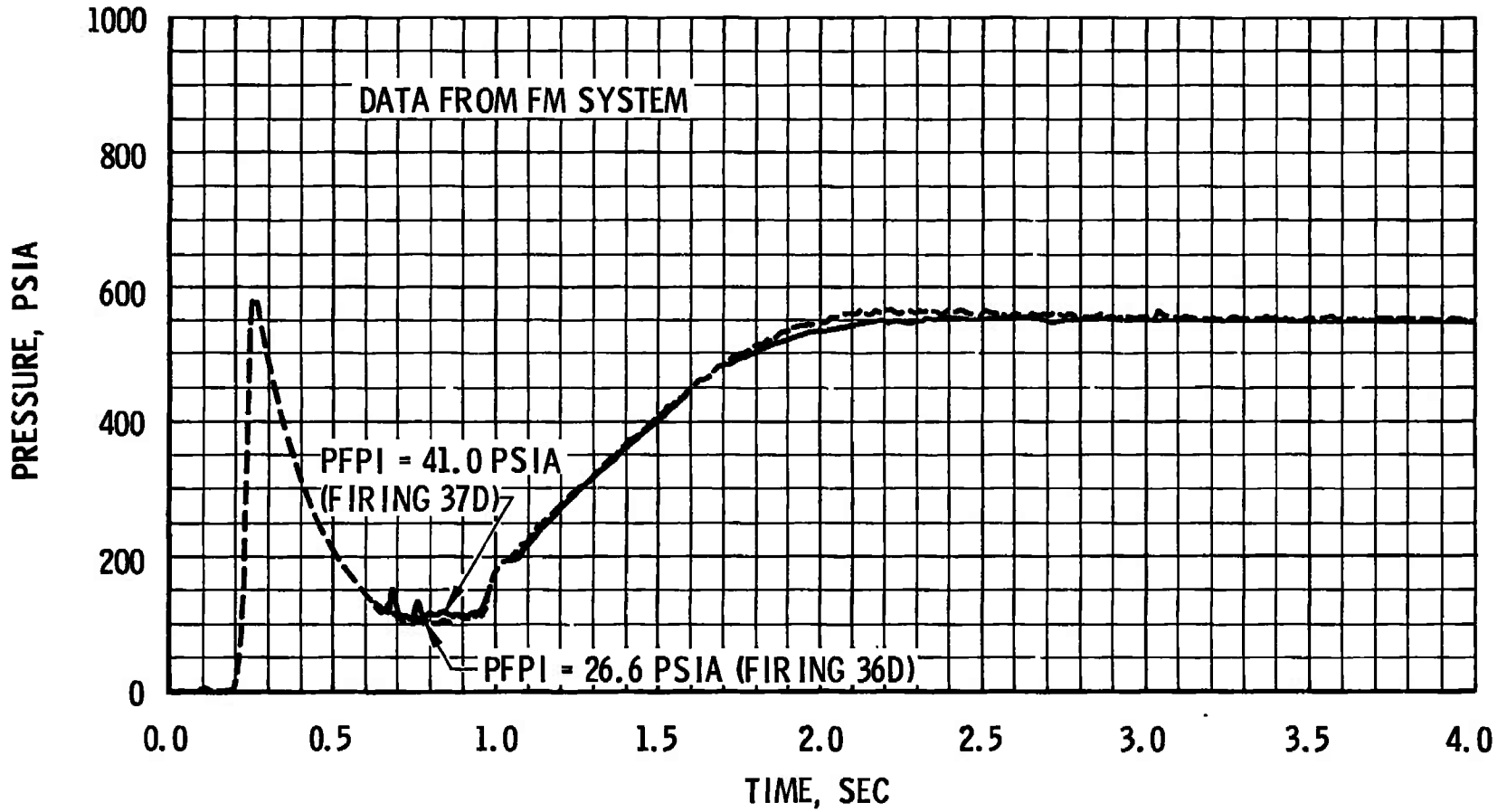

Fig. 63 Fuel Pump Inlet Pressure Effect on Gas Generator Chamber Pressure Transients, Firings 36D and 37D

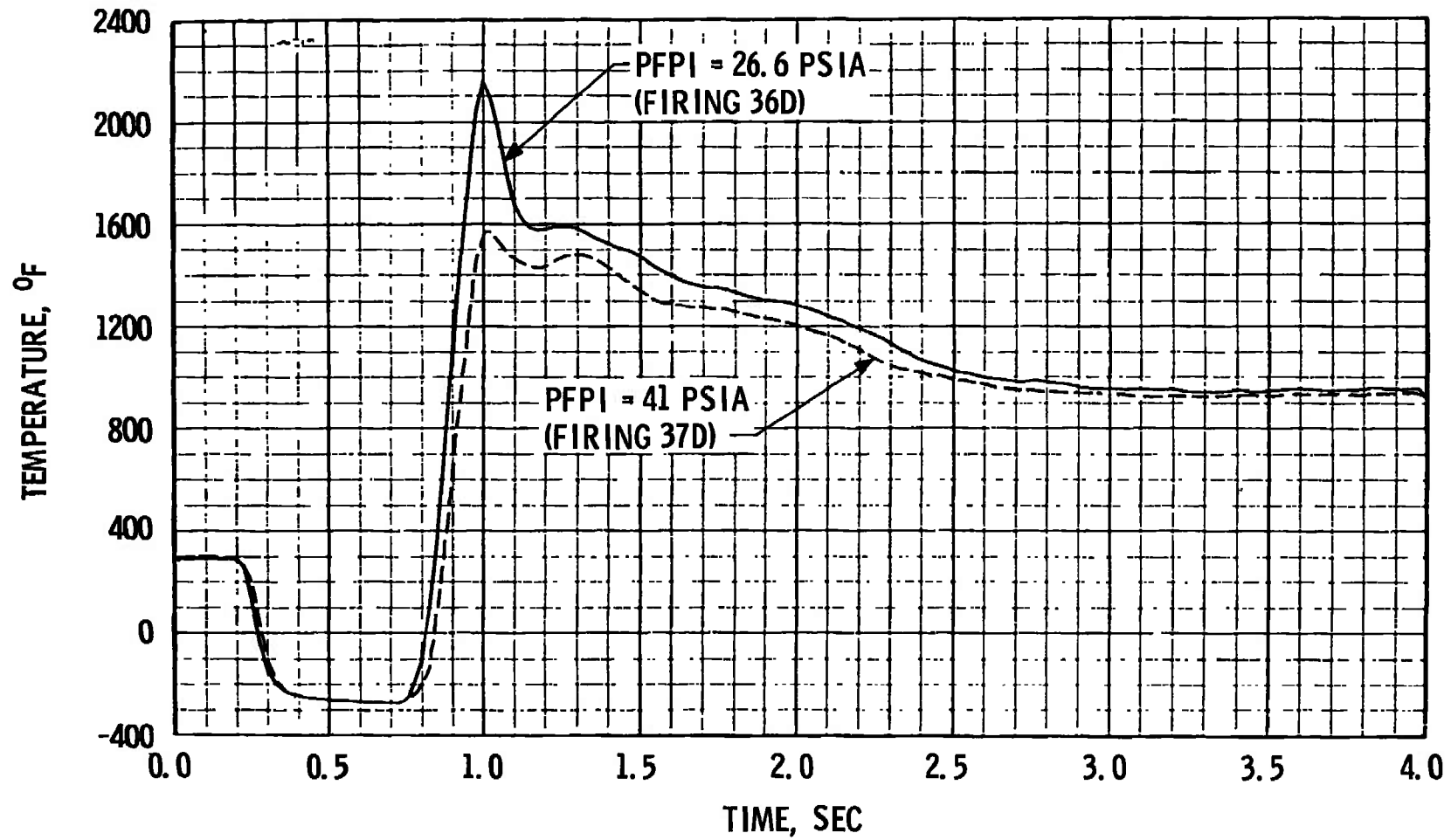

Fig. 64 Fuel Pump Inlet Pressure Effect on Gas Generator Outlet Temperature Transients, Firings 36D and 37D

TABLE I
MAJOR ENGINE COMPONENTS

Part Name	P/N	S/N
Thrust Chamber Body	206600-31	4072755
Thrust Chamber Injector Assembly	208021-11	4071421
Fuel Turbopump Assembly	460160-31	4072328
Oxidizer Turbopump Assembly	458175-81	6645876
Start Tank	303439	0038
Augmented Spark Igniter	206280-81	4078806
Gas Generator Fuel Injector and Combustor	308360-11	4088543
Gas Generator Oxidizer Injector and Poppet Assembly	303323	4091740
Helium Regulator Assembly	4072892	558130-111
Electrical Control Package	502670-51	4087776
Primary Flight Instrumentation Package	703685	4077391
Auxiliary Flight Instrumentation Package	703680	4077313
Main Fuel Valve	409120	4062181
Main Oxidizer Valve	411031	4089563
Gas Generator Control Valve	309040-31	4062168
Start Tank Discharge Valve	304386	40865957
Oxidizer Turbine Bypass Valve	409940	4062266
Propellant Utilization Valve	251351-11	4068732
Main-Stage Control Valve	558065	8275908
Ignition Phase Control Valve	558065	8313742
Helium Control Valve	NA5-27273	340910
Start Tank Vent and Relief Valve	558325	8358552
Helium Tank Vent Valve	NA5-27273	328191
Fuel Bleed Valve	309034	4077233
Oxidizer Bleed Valve	309029	4076750
Augmented Spark Igniter Oxidizer Valve	308880	4089946
Pressure-Actuated Shutdown Valve Assembly	558127-11	4087861
Pressure-Actuated Purge Control Valve	558126	4089662
Start Tank Fill/Refill Valve	558000	4072899
Fuel Flowmeter	251225	4076564
Oxidizer Flowmeter	251216	4077137
Fuel Injector Temperature Transducer	NA5-27441	12350
Restartable Ignition Detect Probe	NA5-27298T2	102

TABLE II
SUMMARY OF ENGINE ORIFICES

Orifice Name	Part Number	Diameter	Date Effective	Comments
Gas Generator Fuel Supply Line	RD251-4107	0.508 in.	March 25, 1968	---
Gas Generator Oxidizer Supply Line	RD251-4106	0.288 in.	March 25, 1968	---
Oxidizer Turbine Bypass Valve Nozzle	RD273-8002	1.541 in.	March 25, 1968	---
Main Oxidizer Valve Closing Control	410437-084	8.45 scfm	April 17, 1968	Thermostatic Orifice
Oxidizer Turbine Exhaust Manifold	RD251-9004	10.0 in.	January 18, 1966	Installed on Engine before Shipment to AEDC
Augmented Spark Igniter Oxidizer Supply Line	406361-3	0.125 in. 0.137 in.	March 21, 1968	Gives an Effective Diameter of 0.110 in.

TABLE III
ENGINE MODIFICATIONS
(BETWEEN TESTS J4-1801-36 AND J4-1801-38)

Modification	Completion Date	Description of Modification
Test J4-1801-36		4/10/68
RFD ¹ 19-68	April 11, 1968	Retimed Main Oxidizer Valve Second-Stage Opening Time to 1650 ⁺¹⁰ -20 msec
RFD 65-1-67	April 12, 1968	Removal of the Gas Generator Oxidizer Supply Line Condi- tioning Sleeve
Test J4-1801-37		4/16/68
RFD 12-68	April 17, 1968	Retimed Main Oxidizer Valve Second-Stage Opening Time to 1700 ⁺³⁰ -0 msec
Test J4-1801-38		4/23/68

¹RFD - Rocketdyne Field Directive

TABLE IV
ENGINE COMPONENT REPLACEMENTS
(BETWEEN TESTS J4-1801-36 AND J4-1801-38)

Replacement	Completion Date	Component Replaced
Test J4-1801-36		4/10/68
UCR ¹ -007391	April 11, 1968	Fuel Turbopump Intermediate Shaft Seal P/N NA5-260115 S/N CR138
UCR-007391	April 11, 1968	Fuel Turbopump Turbine Shaft Seal P/N NA5-26628 S/N P112
Test J4-1801-37		4/16/68
UCR-005113	April 18, 1968	Fuel Turbopump Interstage Pressure Transducer (PF6) P/N NA5-27412T-2T S/N 7904A
Test J4-1801-38		4/23/68

¹UCR - Unsatisfactory Condition Report

TABLE V
ENGINE PURGE AND COMPONENT CONDITIONING SEQUENCE

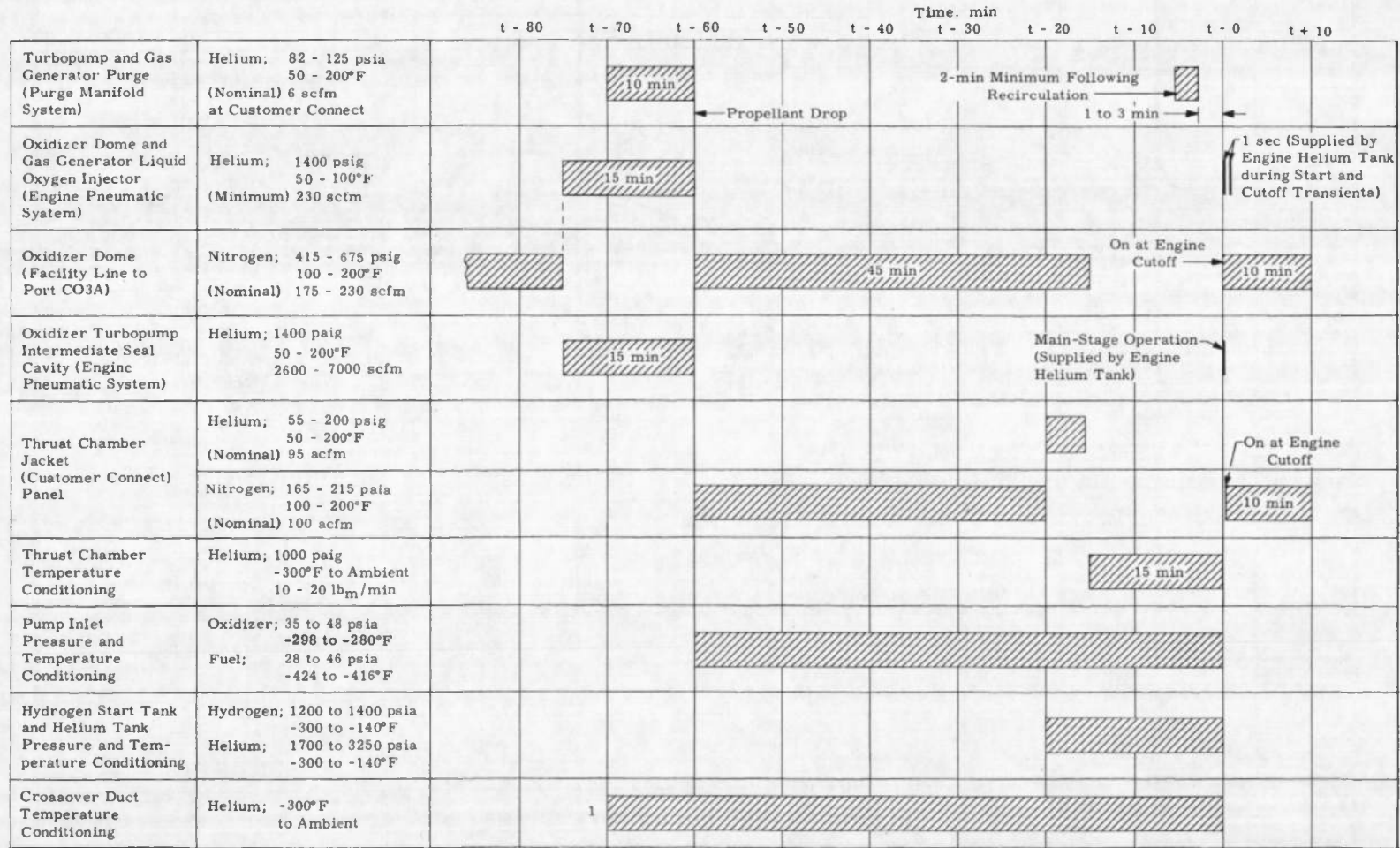

¹Conditioning temperature to be maintained for the last 15 min of pre-fire.

TABLE VI
SUMMARY OF TEST REQUIREMENTS AND RESULTS

AEDC-TR-68-201

Firing Number: J4-1801-		37A		37B		37C		37D		37E	
		Target	Actual	Target	Actual	Target	Actual	Target	Actual	Target	Actual
Times of Day, hr/Firing Date		2225/April 16, 1968		2251/April 18, 1968		2358/April 16, 1968		0024/April 17, 1968		0124/April 17, 1968	
Pressure Altitude at Engine Start, ft (Ref. 1)		100,000	93,000	100,000	102,000	100,000	107,000	100,000	110,000	100,000	112,000
Firing Duration, sec ^①		32.5	32.58	7.5	7.59	32.5	32.58	7.5	7.59	Main-Stage Signal, 0.700	Main-Stage Signal, 0.897
Fuel Pump Inlet Conditions at Engine Start	Pressure, psia	26.5 ⁺¹ ₋₀	26.8	26.5 ⁺¹ ₋₀	26.6	26.5 ⁺¹ ₋₀	27.0	41.0 ± 1.0	41.0	28.5 ⁺¹ ₋₀	28.8
	Temperature, °F	-421.4 ± 0.4	-421.4	-421.4 ± 0.4	-420.9	-421.4 ± 0.4	-421.2	-421.4 ± 0.4	-420.6	-421.4 ± 0.4	-421.4
Oxidizer Pump Inlet Conditions at Engine Start	Pressure, psia	33 ⁺¹ ₋₀	33.3	45 ± 1	45.8	33 ⁺¹ ₋₀	33.5	45 ± 1	45.0	45 ± 1	45.5
	Temperature, °F	-295.0 ± 0.4	-294.9	-295.0 ± 0.4	-294.9	-295.0 ± 0.4	-294.8	-295.0 ± 0.4	-294.7	-295.0 ± 0.4	-294.8
Start Tank Conditions at Engine Start	Pressure, psia	1250 ± 10	1246	1200 ± 10	1195	1250 ± 10	1237	1300 ± 10	1296	1400 ± 10	1380
	Temperature, °F	-140 ± 10	-140	-260 ± 10	-261	-140 ± 10	-148	-265 ± 10	-276	-200 ± 10	-207
Helium Tank Conditions at Engine Start	Pressure, psia	---	2245	---	2340	---	2554	---	2319	---	2817
	Temperature, °F	---	-137	---	-259	---	-161	---	-273	---	-205
Thrust Chamber Temperature Conditions at Engine Start/t ₀ , °F	Throat	-250 ± 25	-248/-254	-200 ± 25	-208/-219	-200 ± 25	-205/-213	-200 ± 25	-209/-217	25 ± 15	18/12
	Average	---	-265/-341	---	-230/-368	---	-231/-367	---	-228/-388	---	19/-66
Crossover Duct Temperature at Engine Start, °F ^②	TFTD-2	-100 ± 20	-103	---	408	-100 ± 20	-99	---	409	50 ⁺⁰ ₋₅₀	24
	TFTD-3	-100 ± 20	-91	170 ⁺⁰ ₋₅	173	-100 ± 20	-99	170 ⁺⁰ ₋₅	171	50 ⁺⁰ ₋₅₀	23
	TFTD-8	-100 ± 20	-83	---	391	-100 ± 20	-98	---	384	50 ⁺⁰ ₋₅₀	18
Main Oxidizer Valve Second-Stage Actuator Temperature at Engine Start, °F ^③		-150 ± 50	-147	-150 ± 50	-155	-150 ± 50	-160	-150 ± 50	-141	---	-170
Fuel Lead Time, sec ^①		3.0	3.001	8.0	7.92	8.0	7.82	8.0	7.82	3.0	3.02
Propellant in Engine Time, min		Minimum 30	112	25	24	Minimum 30	66	25	25	30	69
Propellant Recirculation Time, min		10	10	10	10.5	10	10	10	11.5	10	10
Start Sequence Logic		Normal	Normal	Normal	Normal	Normal	Normal	Normal	Normal	Auxiliary	Auxiliary
Gas Generator Oxidizer Supply Line Temperature at Engine Start, °F	TOBS-2A	---	37	---	32	---	34	---	5	---	25
	TOBS-4	---	7	---	-2	---	5	---	-14	---	-7
Vibration Safety Counts Duration, msec, and Occurrence Time, sec, from t ₀		---	38	---	15	---	55	---	66	---	---
Gas Generator Outlet Temperature, °F	Initial Peak	---	1270	---	1851	---	889	---	1585	---	1294
	Second Peak	---	---	---	---	---	---	---	1487	---	---
Thrust Chamber Ignition (P _C = 100 psia) Time, sec (Ref. t ₀) ^①		---	1.047	---	0.987	---	1.090	---	0.954	---	0.967
Main Oxidizer Valve Second-Stage Initial Movement, sec (Ref. t ₀) ^①		---	0.967	---	0.899	---	1.050	---	0.982	---	1.063
Main-Stage Pressure No. 2, sec (Ref. t ₀) ^①		---	1.805	---	1.680	---	2.080	---	1.825	---	N/A
Time Chamber Pressure Attains 550 psia, sec (Ref. t ₀) ^①		---	2.117	---	2.050	---	2.800	---	1.883	---	N/A
Propellant Utilization Valve Position, Engine Start/t ₀ + 10 sec		Null	Null	Open	Open	Open	Open	Open	Open	Null	Null
		Closed	Closed	---	---	Closed	Closed	---	---	---	---

Notes: ① Data reduced from oscillogram.
 ② Component conditioning to be maintained within limits for last 15 min before engine start.
 ③ Component conditioning to be maintained within limits for last 30 min before engine start or coast duration, whichever is longer.

TABLE VI (Concluded)

Firing Number: J4-1801-		38A		38B		38C		38D		38E	
		Target	Actual	Target	Actual	Target	Actual	Target	Actual	Target	Actual
Time of Day, hr/Firing Date		1101/April 23, 1968		1157/April 23, 1968		1312/April 23, 1968		1338/April 23, 1968		1441/April 23, 1968	
Pressure Altitude at Engine Start, ft (Ref. 1)		100,000	98,600	100,000	103,600	100,000	103,500	100,000	74,000	100,000	109,500
Firing Duration, sec [ⓐ]		32.5	32.57	7.5	1.24	32.5	32.57	7.5	7.59	26.5 ⁺¹ / ₋₀	27.9 ⁺¹ / ₋₀
Fuel Pump Inlet Conditions at Engine Start	Pressure, psia	37 ± 1	38.0	37 ± 1	36.7	41 ± 1	41.2	41 ± 1	41.0	41 ± 1	41.0
	Temperature, °F	-421.4 ± 0.4	-421.4	-420.5 ± 0.4	-420.6	-421.4 ± 0.4	-421.8	-421.4 ± 0.4	-421.1	-421.4 ± 0.4	-420.9
Oxidizer Pump Inlet Conditions at Engine Start	Pressure, psia	40 ± 1	41.3	41 ± 1	41.4	45 ± 1	45.7	45 ± 1	45.1	45 ± 1	45.3
	Temperature, °F	-295.0 ± 0.4	-295.0	-294.5 ± 0.4	-294.9	-285.0 ± 0.4	-294.8	-295.0 ± 0.4	-294.3	-295.0 ± 0.4	-294.4
Start Tank Conditions at Engine Start	Pressure, psia	1250 ± 10	1254	1300 ± 10	1302	1400 ± 10	1390	1300 ± 10	1295	1400 ± 10	1394
	Temperature, °F	-175 ± 10	-177	-200 ± 10	-208	-200 ± 10	-201	-285 ± 10	-268	-200 ± 10	-203
Helium Tank Conditions at Engine Start	Pressure, psia	---	2220	---	2083	---	2167	---	2125	---	2222
	Temperature, °F	---	-171	---	-200	---	-198	---	-264	---	-201
Thrust Chamber Temperature Conditions at Engine Start/t ₀ , °F	Throat TIC-1P/TTC-2 Average at Engine Start/t ₀	-170 ± 15	-157/-164	-100 ± 15	-114/-118	-80 ⁺²⁰ / ₋₁₀	-78/-86	50 ± 50	40/34	50 ± 15	48/41
	---	---	-171/-277	---	-134/-349	---	-99/-211	---	36/-286	---	51/-30
Crossover Duct Temperature at Engine Start, °F [ⓑ]	TTFD-2	-70 ± 15	-68	---	310	50 ⁺⁰ / ₋₅₀	20	---	438	50 ⁺⁰ / ₋₅₀	20
	TTFD-3	-70 ± 15	-53	125 ⁺¹⁵ / ₋₀	125	50 ⁺⁰ / ₋₅₀	19	170 ⁺¹⁵ / ₋₀	173	50 ⁺⁰ / ₋₅₀	23
	TTFD-8	-70 ± 15	-87	---	266	50 ⁺⁰ / ₋₅₀	14	---	396	50 ⁺⁰ / ₋₅₀	18
Main Oxidizer Valve Second-Stage Actuator Temperature at Engine Start, °F [ⓑ]		-150 ± 50	-108	-150 ± 50	-118	-150 ± 50	-161	-150 ± 50	-144	-150 ± 50	-155
Fuel Lead Time, sec [ⓐ]		3.0	3.02	8.0	7.92	3.0	3.02	8.0	7.92	3.0	3.00
Propellant in Engine Time, min		Minimum 30	75	-25	56	Minimum 30	76	-28	26	30	62
Propellant Recirculation Time, min		10	10	10	7	10	10	10	10	10	10
Start Sequence Logic		Normal	Normal	Normal	Normal	Normal	Normal	Normal	Normal	Auxiliary	Auxiliary
Gas Generator Oxidizer Supply Line Temperature at Engine Start, °F	TOBS-1	---	28	---	20	---	17	---	5	---	4
	TOBS-2A	---	31	---	25	---	31	---	30	---	42
	TOBS-4	---	13	---	6	---	1	---	5	---	11
Start Tank Discharge Valve Body Temperature at Engine Start, °F		---	40	---	30	---	-28	---	-27	---	-62
Vibration Safety Counts Duration, msec, and Occurrence Time, sec, from t ₀		---	31 1.018	---	51 1.010	---	15 0.970	---	10 0.855	---	---
Gas Generator Outlet Temperature, °F	Initial Peak	---	1848	---	1233	---	1580	---	1555	---	1255
	Second Peak	---	---	---	1253	---	1545	---	1825	---	1810
Thrust Chamber Ignition (P _c = 100 psia) Time, sec (Ref. t ₀) [ⓐ]		---	1.020	---	1.010	---	0.988	---	0.855	---	0.872
Main Oxidizer Valve Second-Stage Initial Movement, sec (Ref. t ₀) [ⓐ]		---	1.020	---	1.014	---	1.108	---	1.204	---	N/A
Main-Stage Pressure No. 2, sec (Ref. t ₀) [ⓐ]		---	1.718	---	N/A	---	1.562	---	1.820	---	N/A
Time Chamber Pressure Attains 550 psia, sec (Ref. t ₀) [ⓐ]		---	2.017	---	N/A	---	1.858	---	2.018	---	N/A
Propellant Utilization Valve Position, Engine Start/t ₀ + 10 sec		Null Closed	Null Closed	Open ---	Open ---	Null Closed	Null Closed	Open ---	Open ---	Null ---	Null ---

Notes: [ⓐ]Data reduced from oscillogram.
[ⓑ]Component conditioning to be maintained within limits for last 15 min before engine start.
[ⓒ]Component conditioning to be maintained within limits for last 30 min before engine start or coast duration, whichever is longer.

TABLE VII
ENGINE VALVE TIMINGS

Firing Number J4-1801-	Start																							
	Start Tank Discharge Valve						Main Fuel Valve			Main Oxidizer Valve First Stage			Main Oxidizer Valve Second Stage			Gas Generator Fuel Poppet			Gas Generator Oxidizer Poppet			Oxidizer Turbine Bypass Valve		
	Time of Opening Signal	Valve Delay Time, sec	Valve Opening Time, sec	Time of Closing Signal	Valve Delay Time, sec	Valve Closing Time, sec	Time of Opening Signal	Valve Delay Time, sec	Valve Opening Time, sec	Time of Opening Signal	Valve Delay Time, sec	Valve Opening Time, sec	Time of Opening Signal	Valve Delay Time, sec	Valve Opening Time, sec	Time of Opening Signal	Valve Delay Time, sec	Valve Opening Time, sec	Time of Opening Signal	Valve Delay Time, sec	Valve Opening Time, sec	Time of Closing Signal	Valve Delay Time, sec	Valve Closing Time, sec
37A	0	0.127	0.107	0.449	0.128	0.241	-3.001	0.068	0.050	0.448	0.082	0.052	0.449	0.518	1.944	0.449	0.122	0.024	0.449	0.184	0.086	0.449	0.236	0.308
37B	0	0.128	0.115	0.450	0.126	0.246	-7.917	0.059	0.099	0.450	0.060	0.051	0.450	0.549	1.800	0.450	0.121	0.029	0.450	0.194	0.094	0.450	0.223	0.296
37C	0	0.134	0.121	0.450	0.134	0.256	-7.922	0.057	0.074	0.450	0.060	0.058	0.450	0.600	1.709	0.450	0.118	0.030	0.450	0.189	0.091	0.450	0.228	0.306
37D	0	0.130	0.126	0.449	0.120	0.245	-7.920	0.058	0.082	0.448	0.057	0.048	0.449	0.533	1.809	0.449	0.122	0.028	0.449	0.199	0.101	0.449	0.212	0.292
37E	0	0.142	0.133	0.449	0.136	0.260	-3.017	0.059	0.082	0.449	0.062	0.053	0.448	0.815	N/A	0.448	0.128	0.026	0.448	0.206	0.103	0.448	0.212	0.311
Final Sequence	0	0.088	0.091	0.451	0.127	0.236	-1.000	0.049	0.076	0.451	0.052	0.041	0.451	0.538	1.844	0.451	0.082	0.026	0.451	0.142	0.078	0.451	0.200	0.294

Firing Number J4-1801-	Shutdown														
	Main Fuel Valve			Main Oxidizer Valve			Gas Generator Fuel Poppet			Gas Generator Oxidizer Poppet			Oxidizer Turbine Bypass Valve		
	Time of Closing Signal	Valve Delay Time, sec	Valve Closing Time, sec	Time of Closing Signal	Valve Delay Time, sec	Valve Closing Time, sec	Time of Closing Signal	Valve Delay Time, sec	Valve Closing Time, sec	Time of Closing Signal	Valve Delay Time, sec	Valve Closing Time, sec	Time of Opening Signal	Valve Delay Time, sec	Valve Opening Time, sec
37A	32.575	0.114	0.339	32.575	0.082	0.197	32.575	0.076	0.027	32.675	0.030	0.017	32.575	0.241	0.552
37B	7.589	0.110	0.331	7.589	0.076	0.186	7.588	0.084	0.021	7.589	0.038	0.026	7.588	0.224	0.494
37C	32.575	0.112	0.342	32.575	0.087	0.188	32.575	0.082	0.030	32.575	0.035	0.017	32.575	0.229	0.467
37D	7.589	0.106	0.318	7.599	0.077	0.184	7.589	0.085	0.020	7.589	0.039	0.022	7.588	0.214	0.452
37E	1.145	0.109	0.370	1.145	N/A	N/A	1.145	0.095	0.022	1.145	0.050	0.028	1.145	0.123	0.465
Final Sequence	5.153	0.080	0.234	5.153	0.059	0.126	5.153	0.098	0.028	5.153	0.062	0.029	5.153	0.204	0.577

- Notes: 1. All valve signal times are referenced to t_0 .
 2. Valve delay time is the time required for initial valve movement after the valve "open" or "closed" solenoid has been energized.
 3. Final sequence check is conducted without propellants and within 12 hr before testing.
 4. Data reduced from oscillogram.

TABLE VII (Concluded)

Firing Number J4-1801-	Start																							
	Start Tank Discharge Valve						Main Fuel Valve			Main Oxidizer Valve First Stage			Main Oxidizer Valve Second Stage			Gas Generator Fuel Poppet			Gas Generator Oxidizer Poppet			Oxidizer Turbine Bypass Valve		
	Time of Opening Signal	Valve Delay Time, sec	Valve Opening Time, sec	Time of Closing Signal	Valve Delay Time, sec	Valve Closing Time, sec	Time of Opening Signal	Valve Delay Time, sec	Valve Opening Time, sec	Time of Opening Signal	Valve Delay Time, sec	Valve Opening Time, sec	Time of Opening Signal	Valve Delay Time, sec	Valve Opening Time, sec	Time of Opening Signal	Valve Delay Time, sec	Valve Opening Time, sec	Time of Opening Signal	Valve Delay Time, sec	Valve Opening Time, sec	Time of Closing Signal	Valve Delay Time, sec	Valve Closing Time, sec
38A	0	0.124	0.109	0.450	0.126	0.234	-3.016	0.055	0.078	0.450	0.060	0.050	0.450	0.570	2.008	0.450	0.119	0.022	0.450	0.180	0.088	0.450	0.228	0.298
38B	0	0.124	0.114	0.449	0.123	0.243	-7.921	0.055	0.078	0.449	0.057	0.050	0.449	0.565	N/A	0.449	0.115	0.027	0.449	0.185	0.079	0.449	0.203	0.294
38C	0	0.133	0.122	0.450	0.126	0.194	-3.016	0.054	0.070	0.450	0.060	0.055	0.450	0.859	2.129	0.450	0.120	0.026	0.450	0.190	0.082	0.450	0.212	0.294
38D	0	0.134	0.121	0.449	0.130	0.249	-7.920	0.054	0.080	0.449	0.058	0.056	0.449	0.755	1.838	0.449	0.121	0.027	0.449	0.198	0.100	0.449	0.198	0.308
38E	0	0.143	0.130	0.448	0.134	0.257	-3.014	0.055	0.078	0.448	0.059	0.056	0.448	N/A	N/A	0.448	0.128	0.026	0.448	0.202	0.097	0.448	0.220	0.298
Final Sequence	0	0.088	0.093	0.450	0.128	0.240	-1.001	0.048	0.079	0.450	0.054	0.044	0.450	0.560	1.720	0.450	0.092	0.026	0.450	0.142	0.078	0.450	0.210	0.300

Firing Number J4-1801-	Shutdown														
	Main Fuel Valve			Main Oxidizer Valve			Gas Generator Fuel Poppet			Gas Generator Oxidizer Poppet			Oxidizer Turbine Bypass Valve		
	Time of Closing Signal	Valve Delay Time, sec	Valve Closing Time, sec	Time of Closing Signal	Valve Delay Time, sec	Valve Closing Time, sec	Time of Closing Signal	Valve Delay Time, sec	Valve Closing Time, sec	Time of Closing Signal	Valve Delay Time, sec	Valve Closing Time, sec	Time of Opening Signal	Valve Delay Time, sec	Valve Opening Time, sec
38A	32.574	0.112	0.315	32.574	0.076	0.185	32.574	0.073	0.023	32.574	0.032	0.014	32.574	0.250	0.588
38B	1.245	0.098	0.297	1.245	N/A	N/A	1.245	0.081	0.020	1.245	0.044	0.026	1.245	0.140	0.528
38C	32.573	0.114	0.340	32.573	0.084	0.195	32.573	0.077	0.022	32.573	0.032	0.017	32.573	0.237	0.529
38D	7.590	0.103	0.304	7.590	0.077	0.187	7.590	0.085	0.023	7.590	0.039	0.018	7.590	0.210	0.512
38E	1.142	0.107	0.310	1.142	N/A	N/A	1.142	0.085	0.026	1.142	0.047	0.027	1.142	0.124	0.560
Final Sequence	7.362	0.080	0.238	7.362	0.064	0.124	7.362	0.098	0.030	7.362	0.058	0.028	7.362	0.212	0.634

- Notes:
1. All valve signal times are referenced to t_0 .
 2. Valve delay time is the time required for initial valve movement after the valve "open" or "closed" solenoid has been energized.
 3. Final sequence check is conducted without propellants and within 12 hr before testing.
 4. Data reduced from oscillogram.

**TABLE VIII
ENGINE PERFORMANCE SUMMARY**

Firing Number J4-1801-		37A		37C		38A		38C	
		Site	Normalized	Site	Normalized	Site	Normalized	Site	Normalized
Overall Engine Performance	Thrust, lb _f	233,425	230,625	233,395	231,205	236,080	233,355	235,116	232,632
	Chamber Pressure, psia	787.7	774.6	787.3	776.7	796.8	783.8	793.1	780.9
	Mixture Ratio	5.498	5.493	5.465	5.452	5.441	5.440	5.425	5.458
	Fuel Weight Flow, lb _m /sec	85.8	84.4	86.1	85.1	86.7	85.4	87.0	85.4
	Oxidizer Weight Flow, lb _m /sec	471.6	463.8	470.3	463.7	471.9	464.4	471.9	465.8
	Total Weight Flow, lb _m /sec	557.4	548.2	556.4	548.8	558.7	549.7	558.9	551.2
Thrust Chamber Performance	Mixture Ratio	5.706	5.703	5.671	5.659	5.641	5.644	5.626	5.663
	Total Weight Flow, lb _m /sec	550.0	540.9	549.0	541.4	551.3	542.4	551.5	543.9
	Characteristic Velocity, ft/sec	7840	7839	7850	7852	7912	7909	7872	7860
Fuel Turbopump Performance	Pump Efficiency, percent	73.2	73.2	73.1	73.1	72.9	72.9	72.7	72.7
	Pump Speed, rpm	27,570	27,367	27,654	27,453	27,813	27,610	27,763	27,522
	Turbine Efficiency, percent	61.1	61.0	61.4	61.3	62.6	62.5	62.1	61.9
	Turbine Pressure Ratio	7.38	7.38	7.39	7.39	7.27	7.27	7.36	7.36
	Turbine Inlet Temperature, °F	1246	1226	1244	1223	1260	1241	1250	1235
	Turbine Weight Flow, lb _m /sec	7.37	7.29	7.39	7.33	7.36	7.28	7.40	7.33
Oxidizer Turbopump Performance	Pump Efficiency, percent	80.5	80.4	80.4	80.4	80.4	80.4	80.4	80.4
	Pump Speed, rpm	8749	8674	8771	8696	8811	8738	8792	8720
	Turbine Efficiency, percent	49.2	49.1	49.8	49.7	50.8	50.6	50.1	49.9
	Turbine Pressure Ratio	2.66	2.65	2.65	2.65	2.62	2.62	2.62	2.62
	Turbine Inlet Temperature, °F	799	785	787	771	803	789	802	792
	Turbine Weight Flow, lb _m /sec	6.42	6.35	6.42	6.37	6.39	6.32	6.44	6.37
Gas Generator Performance	Mixture Ratio	0.967	0.955	0.966	0.953	0.976	0.964	0.969	0.960
	Chamber Pressure, psia	718.5	708.3	719.4	711.4	719.0	709.1	721.5	712.7

- Note:
1. Site data are calculated from test data.
 2. Normalized data are corrected to standard pump inlet and engine ambient pressure conditions.
 3. Input data are test data averaged from 29 to 30 sec, except as noted.
 4. Site and normalized data were computed using the Rocketdyne PAST 640 modification zero computer program.

APPENDIX III INSTRUMENTATION

The instrumentation for AEDC tests J4-1801-37 and J4-1801-38 is tabulated in Table III-1. The location of selected major engine instrumentation is shown in Fig. III. 1.

TABLE III-1
INSTRUMENTATION LIST

<u>AEDC Code</u>	<u>Parameter</u>	<u>Tap No.</u>	<u>Range</u>	<u>Micro-SADIC</u>	<u>Magnetic Tape</u>	<u>Oscillo-graph</u>	<u>Strip Chart</u>	<u>X-Y Plotter</u>
	<u>Current</u>		<u>amp</u>					
ICC	Control		0 to 30	x		x		
IIC	Ignition		0 to 30	x		x		
	<u>Event</u>							
EASIOV	Augmented Spark Igniter Oxidizer Valve Open		On/Off	x		x		
EECL	Engine Cutoff Lockin		On/Off	x		x		
EECO	Engine Cutoff Signal		On/Off	x	x	x		
EES	Engine Start Command		On/Off	x		x		
EFBVC	Fuel Bleed Valve Closed Limit		Open/Closed	x				
EFPVC/O	Fuel Prevalve Closed/Open Limit		Closed/Open	x				
EHCS	Helium Control Solenoid		On/Off	x		x		
EID	Ignition Detected		On/Off	x		x		
EIPCS	Ignition Phase Control Solenoid		On/Off	x		x		
EMCS	Main-Stage Control Solenoid		On/Off	x		x		
EMP-1	Main-Stage Pressure No. 1		On/Off	x		x		
EMP-2	Main-Stage Pressure No. 2		On/Off	x		x		
EOBVC	Oxidizer Bleed Valve Closed Limit		Open/Closed	x				
EOPVC	Oxidizer Prevalve Closed Limit		Closed	x		x		
EOPVO	Oxidizer Prevalve Open Limit		Open	x		x		
ESTDCS	Start Tank Discharge Control Solenoid		On/Off	x	x	x		
RASIS-1	Augmented Spark Igniter Spark No. 1		On/Off			x		
RASIS-2	Augmented Spark Igniter Spark No. 2		On/Off			x		
RGGS-1	Gas Generator Spark No. 1		On/Off			x		
RGGS-2	Gas Generator Spark No. 2		On/Off			x		
	<u>Flows</u>		<u>gpm</u>					
QF-1A	Fuel	PFF	0 to 9000	x		x		
QF-2	Fuel	PFFA	0 to 9000	x	x	x		
QF-1 SAM	Fuel Flow Stall Approach Monitor		0 to 9000	x		x		
QFRP	Fuel Reclrculation		0 to 160	x				
QO-1A	Oxidizer	POF	0 to 3000	x		x		
QO-2	Oxidizer	POFA	0 to 3000	x	x	x		
QORP	Oxidizer Reclrculation		0 to 50	x				x
	<u>Position</u>		<u>Percent Open</u>					
LFVT	Main Fuel Valve		0 to 100	x		x		
LGGVT	Gas Generator Valve		0 to 100	x		x		
LOTBVT	Oxidizer Turbine Bypass Valve		0 to 100	x		x		
LOVT	Main Oxidizer Valve		0 to 100	x	x	x		
LPUTOP	Propellant Utilization Valve		0 to 100	x		x		x
LSTDVT	Start Tank Discharge Valve		0 to 100	x		x		

TABLE III-1 (Continued)

<u>AEDC Code</u>	<u>Parameter</u>	<u>Tap No.</u>	<u>Range</u>	<u>Micro-SADIC</u>	<u>Magnetic Tape</u>	<u>Oscillo-graph</u>	<u>Strip Chart</u>	<u>X-Y Plotter</u>
	<u>Pressure</u>		<u>psia</u>					
PA1	Test Cell		0 to 0.5	x		x		
PA2	Test Cell		0 to 1.0	x	x			
PA3	Test Cell		0 to 5.0	x			x	
PC-1P	Thrust Chamber	CG1	0 to 1000	x			x	
PC-3	Thrust Chamber	CG1A	0 to 1000	x	x	x		
PCBO	Conatant Bleed Orifice		0 to 50	x				
PCGG-1P	Gas Generator Chamber Pressure		0 to 1000	x	x	x		
PCGG-2	Gas Generator Chamber	GG1A	0 to 1000	x				
PFASIJ	Augmented Spark Igniter Fuel Injection		0 to 1000	x				
PFJ-1A	Main Fuel Injection	CF2	0 to 1000	x		x		
PFJ-2	Main Fuel Injection	CF2A	0 to 1000	x	x			
PFJGG-1A	Gas Generator Fuel Injection	GF4	0 to 1000	x				
PFJGG-2	Gas Generator Fuel Injection	GF4	0 to 1000	x		x		
PFMI	Fuel Jacket Inlet Manifold	CF1	0 to 2000	x				
PFPC-1A	Fuel Pump Balance Piston Cavity	PF5	0 to 1000	x				
PFPD-1P	Fuel Pump Discharge	PF3	0 to 1500	x				x
PFPD-2	Fuel Pump Discharge	PF2	0 to 1500	x	x	x		
PFPI-1	Fuel Pump Inlet		0 to 100	x		x		x
PFPI-2	Fuel Pump Inlet		0 to 200	x		x		x
PFPI-3	Fuel Pump Inlet		0 to 200		x			
PFPPSD-1	Fuel Pump Primary Seal Drain		0 to 200	x				
PFPPSD-2	Fuel Pump Primary Seal Drain		0 to 100	x				
PFPS-1P	Fuel Pump Interstage	PF6	0 to 200	x				
PFRPO	Fuel Recirculation Pump Outlet		0 to 60	x				
PFRRP	Fuel Recirculation Pump Return		0 to 50	x				
PFST-1P	Fuel Start Tank	TF1	0 to 1500	x		x		
PFST-2	Fuel Start Tank	TF1	0 to 1500	x				x
PFTSP-1	Fuel Turbine Seal Purge Line		0 to 100	x				
PFUT	Fuel Tank Ullage		0 to 100	x				
PFVI	Fuel Tank Pressurization Line Nozzle Inlet		0 to 1000	x				
PFVL	Fuel Tank Pressurization Line Nozzle Throat		0 to 1000	x				
PGGOC	Gas Generator Opening Control		0 to 500	x				
PGGVB	Gas Generator Valve Body		0 to 50	x				
PHECMO	Pneumatic Control Module Outlet		0 to 750	x				
PHEOP	Oxidizer Recirculation Pump Purge		0 to 150	x				
PHES	Helium Supply		0 to 5000	x				
PHET-1P	Helium Tank	NN1	0 to 3500	x		x		

TABLE III-1 (Continued)

<u>AEDC Code</u>	<u>Parameter</u>	<u>Tap No.</u>	<u>Range</u>	<u>Micro-SADIC</u>	<u>Magnetic Tape</u>	<u>Oscillo-graph</u>	<u>Strip Chart</u>	<u>X-Y Plotter</u>
<u>Pressure (Con't)</u>								
PHET-2	Helium Tank	NN1	0 to 3500	x				x
PHRO-1A	Helium Regulator Outlet	NN2	0 to 750	x	x			
POBSC	Oxidizer Bootstrap Conditioning		0 to 50	x				
POBV	Gas Generator Oxidizer Bleed Valve	GO2	0 to 2000	x				
POJ-1A	Main Oxidizer Injection	CO3	0 to 1000	x		x		
POJ-2	Main Oxidizer Injection	CO3A	0 to 1000	x		x		
POJGG-1A	Gas Generator Oxidizer Injection	GO5	0 to 1000	x		x		
POJGG-2	Gas Generator Oxidizer Injection	GO5	0 to 1000	x				
POPBC-1A	Oxidizer Pump Bearing Coolant	PO7	0 to 500	x				
POPD-1P	Oxidizer Pump Discharge	PO3	0 to 1500	x				
POPD-2	Oxidizer Pump Discharge	PO2	0 to 1500	x	x	x		
POPI-1	Oxidizer Pump Inlet		0 to 100	x				x
POPI-2	Oxidizer Pump Inlet		0 to 200	x				x
POPI-3	Oxidizer Pump Inlet		0 to 100			x		
POPSC-1A	Oxidizer Pump Primary Seal Cavity	PO6	0 to 50	x				
PORPO	Oxidizer Recirculation Pump Outlet		0 to 115	x				
PORPR	Oxidizer Recirculation Pump Return		0 to 100	x				
POTI-1A	Oxidizer Turbine Inlet	TG3	0 to 200	x				
POTO-1A	Oxidizer Turbine Outlet	TG4	0 to 100	x				
POUT	Oxidizer Tank Ullage		0 to 100	x				
POVCC	Main Oxidizer Valve Closing Control		0 to 500	x	x			
POVI	Oxidizer Tank Pressurization Line Nozzle Inlet		0 to 1000	x				
POVL	Oxidizer Tank Pressurization Line Nozzle Throat		0 to 1000	x				
PPUVI-1A	Propellant Utilization Valve Inlet	PO8	0 to 1000	x				
PPUVO-1A	Propellant Utilization Valve Outlet	PO9	0 to 500	x				
PTCFJP	Thrust Chamber Fuel Jacket Purge		0 to 100	x				
PTCP	Thrust Chamber Purge		0 to 15	x				
PTPP	Turbopump and Gas Generator Purge		0 to 250	x				
<u>Speeds</u>								
			<u>rpm</u>					
NFP-1P	Fuel Pump	PFV	0 to 30,000	x	x	x		
NFRP	Fuel Recirculation Pump		0 to 15,000	x				
NOP-1P	Oxidizer Pump	POV	0 to 12,000	x	x	x		

TABLE III-1 (Continued)

<u>AEDC Code</u>	<u>Parameter</u>	<u>Tap No.</u>	<u>Range</u>	<u>Micro-SADIC</u>	<u>Magnetic Tape</u>	<u>Oscillo-graph</u>	<u>Strip Chart</u>	<u>X-Y Plotter</u>
	<u>Speeds (Con't)</u>		<u>rpm</u>					
NORP	Oxidizer Recirculation Pump		0 to 15,000	x				
	<u>Temperatures</u>		<u>°F</u>					
TA1	Test Cell (North)		-50 to +800	x				
TA2	Test Cell (East)		-50 to +800	x				
TA3	Test Cell (South)		-50 to +800	x				
TA4	Test Cell (West)		-50 to +800	x				
TAIP-1A	Auxiliary Instrument Package		-300 to +200	x				
TBPM	Bypass Manifold		-325 to +200	x				
TBSC	Oxidizer Bootstrap Conditioning		-350 to +150	x				
TECP-1P	Electrical Controls Package	NST1A	-300 to +200	x			x	
TFASIJ	Augmented Spark Igniter Fuel Injection	IFT1	-425 to +100	x		x		
TFASIL-1	Augmented Spark Igniter Line		-300 to +200	x				
TFASIL-2	Augmented Spark Igniter Line		-300 to +300	x				
TFBV-1A	Fuel Bleed Valve	GFT1	-425 to -375	x				
TFD-1	Fire Detection		0 to 1000	x			x	
TFJ-1P	Main Fuel Injection	CFT2	-425 to +250	x	x	x		
TFPD-1P	Fuel Pump Discharge	PFT1	-425 to -400	x	x	x		
TFPD-2	Fuel Pump Discharge	PFT1	-425 to -400	x				
TFPDD	Fuel Pump Discharge Duct		-320 to +300	x				
TFPI-1	Fuel Pump Inlet		-425 to -400	x				x
TFPI-2	Fuel Pump Inlet		-425 to -400	x				x
TFPPSD-1	Fuel Pump Primary Seal Drain		-425 to +100	x				
TFPSP-1	Fuel Pump Seal Purge		-425 to +100	x				
TFRPO	Fuel Recirculation Pump Outlet		-425 to -410	x				
TFRPR	Fuel Recirculation Pump Return Line		-425 to -250	x				
TFRT-1	Fuel Tank		-425 to -410	x				
TFRT-3	Fuel Tank		-425 to -410	x				
TFST-1P	Fuel Start Tank	TFT1	-350 to +100	x				
TFST-2	Fuel Start Tank	TFT1	-350 to +100	x				x
TFTD-1	Fuel Turbine Discharge Duct		-200 to +800	x				
TFTD-2	Fuel Turbine Discharge Duct		-200 to +1000	x				
TFTD-3	Fuel Turbine Discharge Duct		-200 to +1000	x			x	
TFTD-4	Fuel Turbine Discharge Duct		-200 to +1000	x				
TFTD-5	Fuel Turbine Discharge Duct		-200 to +1400	x				
TFTD-6	Fuel Turbine Discharge Duct		-200 to +1400	x				
TFTD-7	Fuel Turbine Discharge Duct		-200 to +1400	x				
TFTD-8	Fuel Turbine Discharge Duct		-200 to +1400	x			x	
TFTO	Fuel Turbine Outlet	TFT2	0 to 1800	x				

TABLE III-1 (Continued)

AEDC Code	Parameter	Tap No.	Range	Micro-SADIC	Magnetic Tape	Oscillo-graph	Strip Chart	X-Y Plotter
<u>Temperatures (Con't)</u>			<u>°F</u>					
TFTSD-1	Fuel Turbine Seal Drain Line		-300 to +100	x				
TGGO-1A	Gas Generator Outlet	GGT1	0 to 1800	x		x	x	
TGGVRS	Gas Generator Valve Retaining Screw		-100 to +100	x			x	
THET-1P	Helium Tank	NNT1	-350 to +100	x				x
TMFV-1	Main Fuel Valve		-100 to +300	x				
TMFV-2	Main Fuel Valve		-100 to +300	x				
TNODP	Liquid Oxygen Dome Purge		0 to -300	x				
TOBS-1	Oxidizer Bootstrap Line		-300 to +250	x				
TOBS-2	Oxidizer Bootstrap Line		-300 to +250	x				
TOBS-2A	Oxidizer Bootstrap Line		-300 to +250	x				
TOBS-2B	Oxidizer Bootstrap Line		-300 to +250	x				
TOBS-4	Oxidizer Bootstrap Line		-300 to +250	x				
TOBV-1A	Oxidizer Bleed Valve	GOT2	-300 to -250	x				
TOPB-1A	Oxidizer Pump Bearing Coolant	POT4	-300 to -250	x				
TOPD-1P	Oxidizer Pump Discharge	POT3	-300 to -250	x	x	x	x	
TOPD-2	Oxidizer Pump Discharge	POT3	-300 to -250	x				
TOPI-1	Oxidizer Pump Inlet		-310 to -270	x				x
TOPI-2	Oxidizer Pump Inlet		-310 to -270	x				x
TORPO	Oxidizer Recirculation Pump Outlet		-300 to -250	x				
TORPR	Oxidizer Recirculation Pump Return		-300 to -140	x				
TORT-1	Oxidizer Tank		-300 to -287	x				
TORT-1B	Oxidizer Tank		-300 to -287	x				
TORT-3	Oxidizer Tank		-300 to -287	x				
TOTI-1P	Oxidizer Turbine Inlet	TGT3	0 to 1200	x			x	
TOTO-1P	Oxidizer Turbine Outlet	TGT4	0 to 1000	x				
TOVL	Oxidizer Tank Pressurization Line Nozzle Throat		-300 to +100	x				
TPCC	Prechill Controller		-425 to -300	x				
TPIP-1P	Primary Instrument Package		-300 to +200	x				
TSC2-1	Thrust Chamber Skin		-300 to +500	x				
TSC2-2	Thrust Chamber Skin		-300 to +500	x				
TSC2-3	Thrust Chamber Skin		-300 to +500	x				
TSC2-4	Thrust Chamber Skin		-300 to +500	x				
TSC2-5	Thrust Chamber Skin		-300 to +500	x				
TSC2-6	Thrust Chamber Skin		-300 to +500	x				
TSC2-7	Thrust Chamber Skin		-300 to +500	x				
TSC2-8	Thrust Chamber Skin		-300 to +500	x				
TSC2-9	Thrust Chamber Skin		-300 to +500	x				

TABLE III-1 (Concluded)

<u>AEDC Code</u>	<u>Parameter</u>	<u>Tap No.</u>	<u>Range</u>	<u>Micro-SADIC</u>	<u>Magnetic Tape</u>	<u>Oscillo-graph</u>	<u>Strip Chart</u>	<u>X-Y Plotter</u>
<u>Temperatures (Con't)</u>			<u>°F</u>					
TSC2-10	Thrust Chamber Skin		-300 to +500	x				
TSC2-11	Thrust Chamber Skin		-300 to +500	x				
TSC2-12	Thrust Chamber Skin		-300 to +500	x				
TSC2-13	Thrust Chamber Skin		-300 to +500	x			x	
TSC2-14	Thrust Chamber Skin		-300 to +500	x				
TSC2-15	Thrust Chamber Skin		-300 to +500	x				
TSC2-16	Thrust Chamber Skin		-300 to +500	x				
TSC2-17	Thrust Chamber Skin		-300 to +500	x				
TSC2-18	Thrust Chamber Skin		-300 to +500	x				
TSC2-19	Thrust Chamber Skin		-300 to +500	x				
TSC2-20	Thrust Chamber Skin		-300 to +500	x				
TSC2-21	Thrust Chamber Skin		-300 to +500	x				
TSC2-22	Thrust Chamber Skin		-300 to +500	x				
TSC2-23	Thrust Chamber Skin		-300 to +500	x				
TSC2-24	Thrust Chamber Skin		-300 to +500	x				
TSOVAL-1	Oxidizer Valve Closing Control Line		-200 to +100	x				
TSOVC-1	Oxidizer Valve Actuator Cap		-325 to +150	x			x	
TSTC	Start Tank Conditioning		-350 to +150	x				
TSTDVOC	Start Tank Discharge Valve Opening Control Port		-350 to +100	x			x	
TTC-1P	Thrust Chamber Jacket (Control)	CS1	-425 to +500	x			x	
TTC-2	Thrust Chamber Jacket (Control)	CS1A	-425 to +500	x				
TTCEP-1	Thrust Chamber Exit		-425 to +500	x				
TTPP	Turbopump Purge		-150 to +150	x			x	
TXOC	Crossover Duct Conditioning		-325 to +200	x				
<u>Vibrations</u>			<u>g's</u>					
UFPR	Fuel Pump Radial 90 deg		±200		x	x		
UOPR	Oxidizer Pump Radial 90 deg		±200		x			
UTCD-1	Thrust Chamber Dome		±500		x	x		
UTCD-2	Thrust Chamber Dome		±500		x	x		
UTCD-3	Thrust Chamber Dome		±500		x	x		
U1VSC	No. 1 Vibration Safety Counts		On/Off				x	
U2VSC	No. 2 Vibration Safety Counts		On/Off				x	
<u>Voltage</u>			<u>volts</u>					
VCB	Control Bus		0 to 36	x			x	
VIB	Ignition Bus		0 to 36	x			x	
VIDA	Ignition Detect Amplifier		9 to 16	x			x	
VPUTEF	Propellant Utilization Valve Excitation		0 to 5	x				

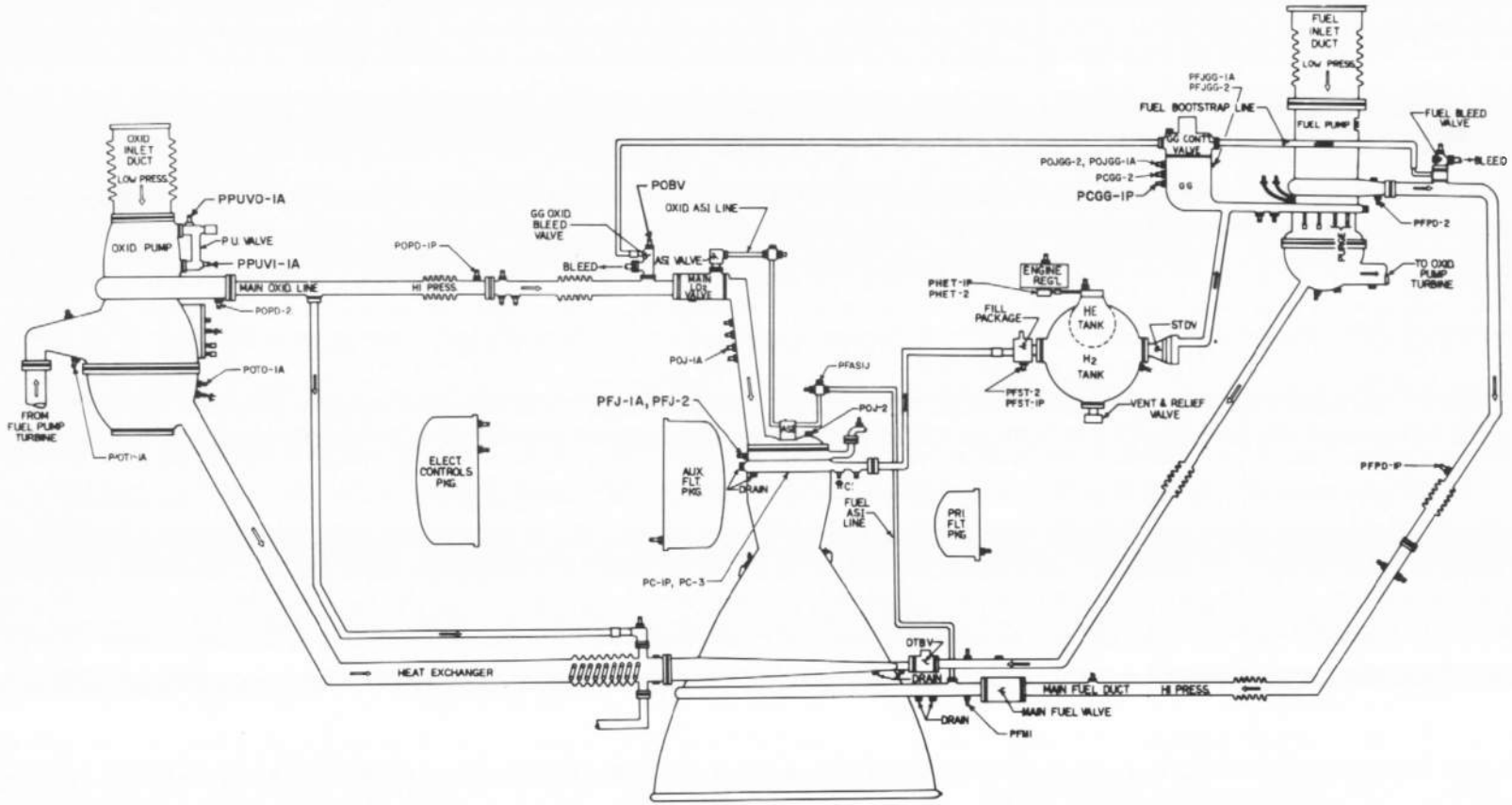

a. Engine Pressure Tap Locations
Fig. III-1 Instrumentation Locations

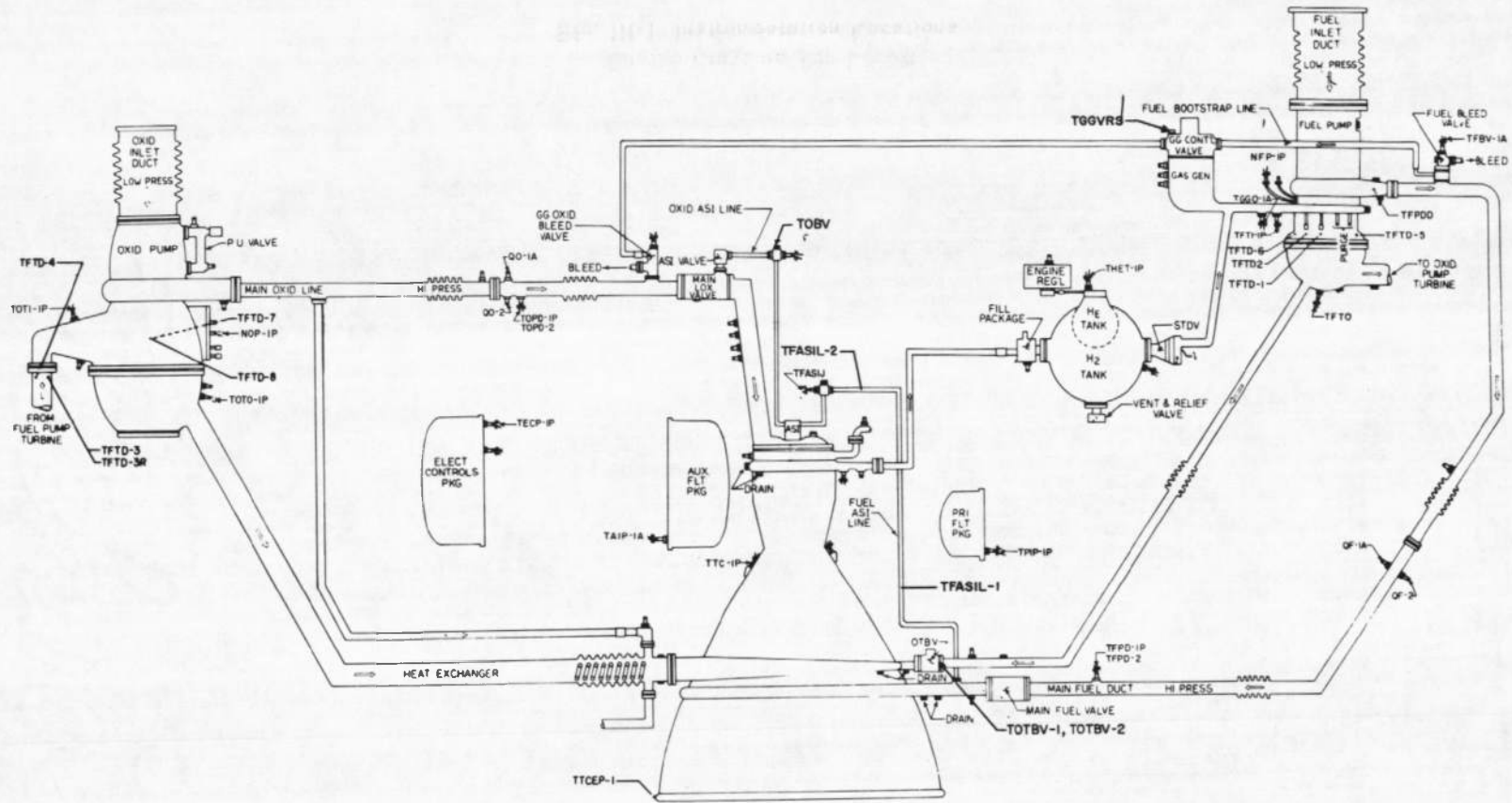

b. Engine Temperature, Flow, and Speed Instrumentation Locations
Fig. III-1 Continued

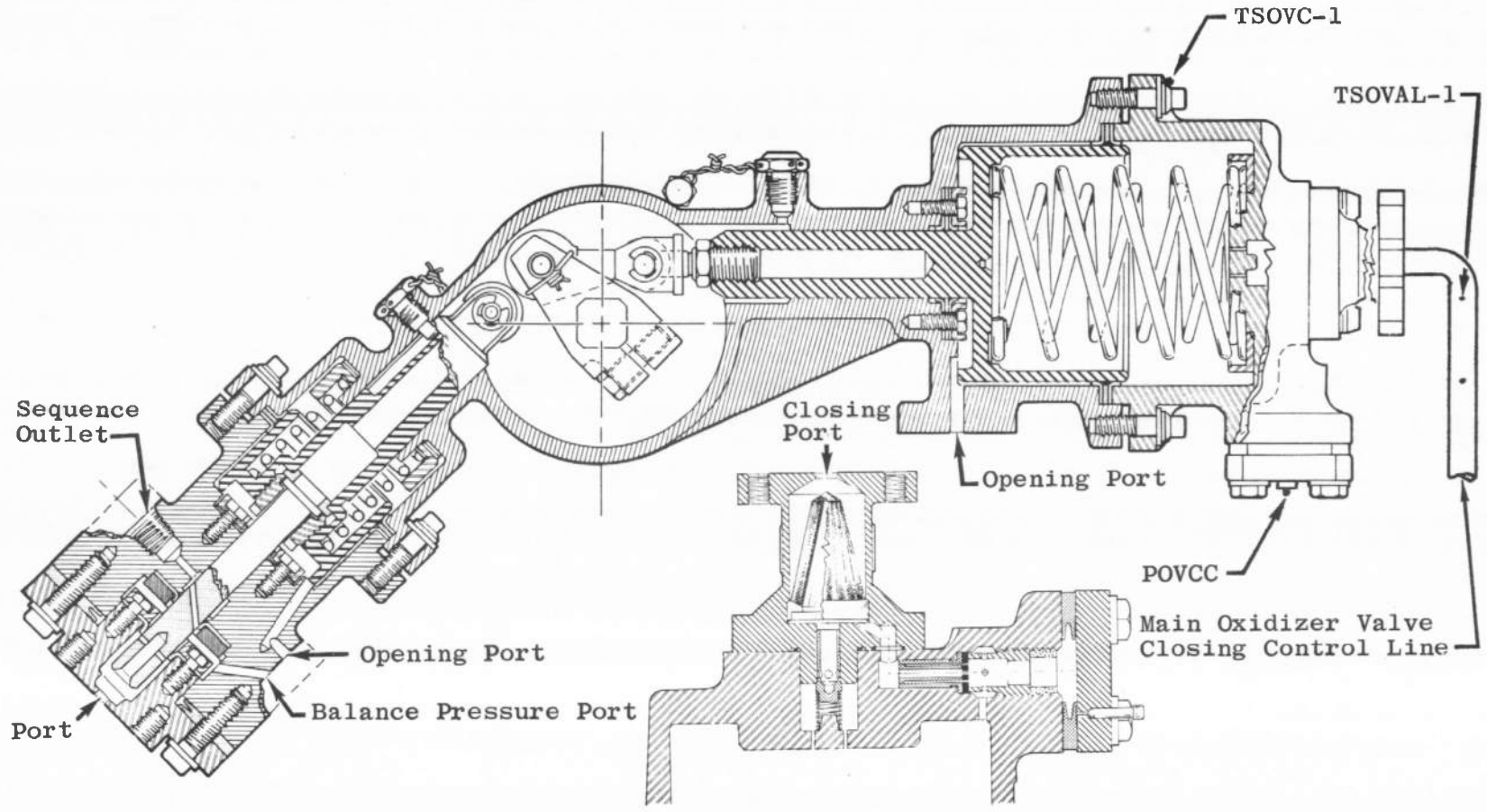

c. Main Oxidizer Valve
Fig. III-1 Continued

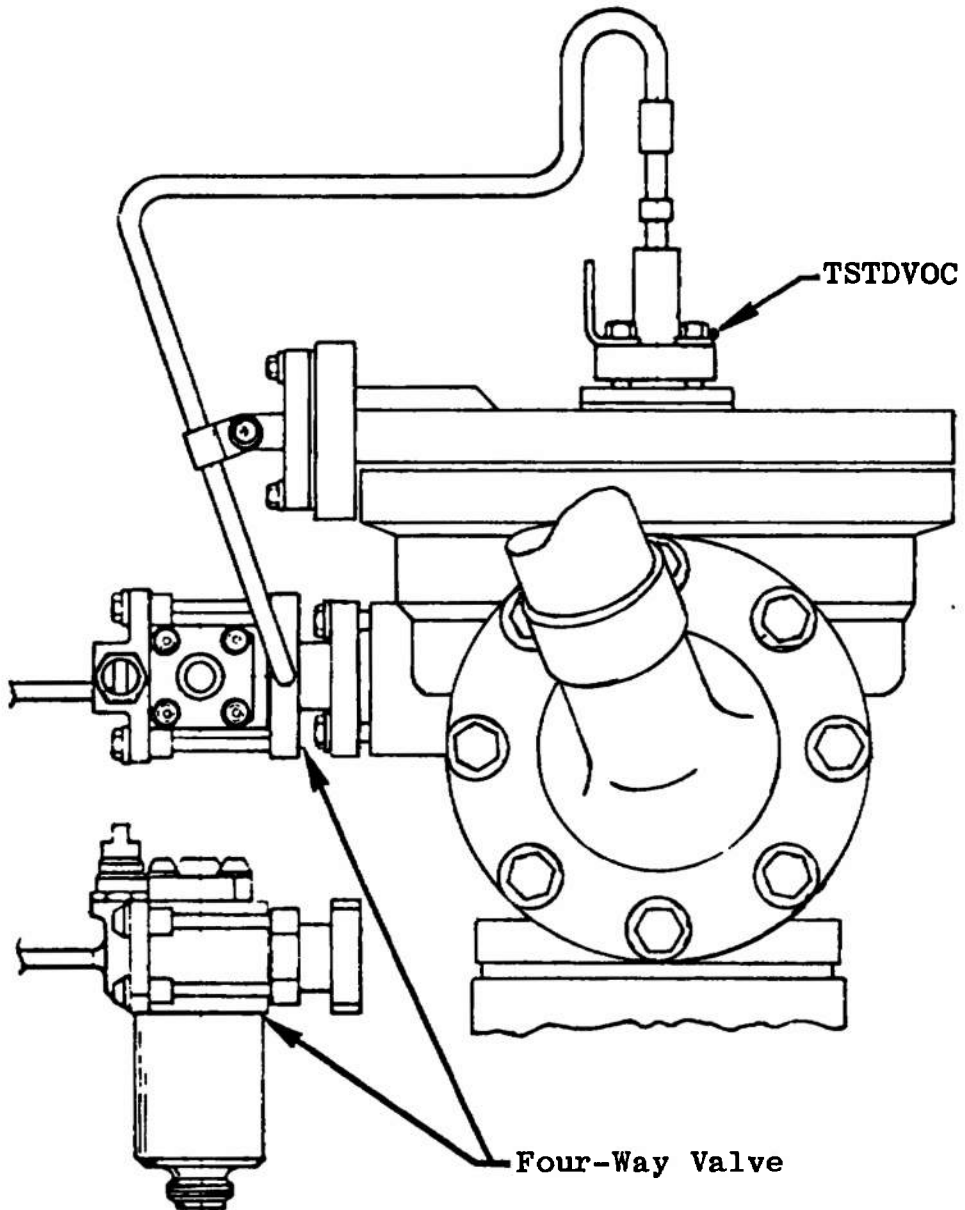

d. Start Tank Discharge Valve
Fig. III-1 Continued

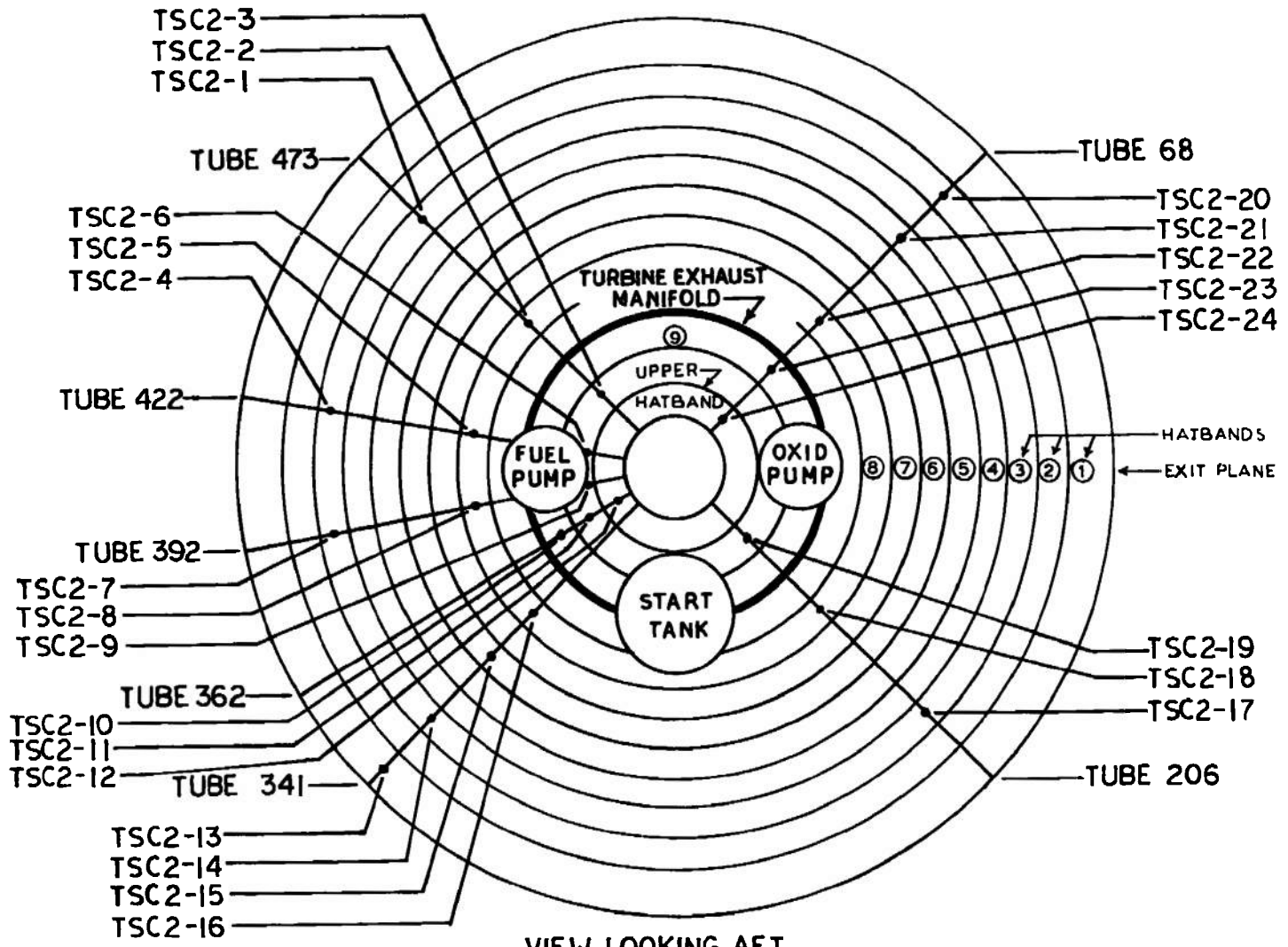

VIEW LOOKING AFT

e. Thrust Chamber

Fig. III-1 Concluded

**APPENDIX IV
METHOD OF CALCULATION (PERFORMANCE PROGRAM)**

**TABLE IV-1
PERFORMANCE PROGRAM DATA INPUTS**

Item No.	Parameter
1	Thrust Chamber (Injector Face) Pressure, psia
2	Thrust Chamber Fuel and Oxidizer Injection Pressures, psia
3	Thrust Chamber Fuel Injection Temperature, °F
4	Fuel and Oxidizer Flowmeter Speeds, Hz
5	Fuel and Oxidizer Engine Inlet Pressures, psia
6	Fuel and Oxidizer Pump Discharge Pressures, psia
7	Fuel and Oxidizer Engine Inlet Temperatures, °F
8	Fuel and Oxidizer (Main Valves) Temperatures, °F
9	Propellant Utilization Valve Center Tap Voltage, volts
10	Propellant Utilization Valve Position, volts
11	Fuel and Oxidizer Pump Speeds, rpm
12	Gas Generator Chamber Pressure, psia
13	Gas Generator (Bootstrap Line at Bleed Valve) Temperature, °F
14	Fuel* and Oxidizer Turbine Inlet Pressure, psia
15	Oxidizer Turbine Discharge Pressure, psia
16	Fuel and Oxidizer Turbine Inlet Temperature, °F
17	Oxidizer Turbine Discharge Temperature, °F

*At AEDC, fuel turbine inlet pressure is calculated from gas generator chamber pressure.

NOMENCLATURE

A	Area, in. ²
B	Horsepower, hp
C*	Characteristic velocity, ft/sec
C _p	Specific heat at constant pressure, Btu/lb/°F
D	Diameter, in.
H	Head, ft
h	Enthalpy, Btu/lb _m
M	Molecular weight
N	Speed, rpm
P	Pressure, psia
Q	Flow rate, gpm
R	Resistance, sec ² /ft ³ -in. ²
r	Mixture ratio
T	Temperature, °F
TC*	Theoretical characteristic velocity, ft/sec
W	Weight flow, lb/sec
Z	Pressure drop, psi
β	Ratio
γ	Ratio of specific heats
η	Efficiency
θ	Degrees
ρ	Density, lb/ft ³

SUBSCRIPTS

A	Ambient
AA	Ambient at thrust chamber exit
B	Bypass nozzle

BIR	Bypass nozzle inlet (Rankine)
BNI	Bypass nozzle inlet (total)
C	Thrust chamber
CF	Thrust chamber, fuel
CO	Thrust chamber, oxidizer
CV	Thrust chamber, vacuum
E	Engine
EF	Engine fuel
EM	Engine measured
EO	Engine oxidizer
EV	Engine, vacuum
e	Exit
em	Exit measured
F	Thrust
FIT	Fuel turbine inlet
FM	Fuel measured
FY	Thrust, vacuum
f	Fuel
G	Gas generator
GF	Gas generator fuel
GO	Gas generator oxidizer
H1	Hot gas duct No. 1
H1R	Hot gas duct No. 1 (Rankine)
H2R	Hot gas duct No. 2 (Rankine)
IF	Inlet fuel
IO	Inlet oxidizer
ITF	Isentropic turbine fuel
ITO	Isentropic turbine oxidizer
N	Nozzle
NB	Bypass nozzle (throat)

NV	Nozzle, vacuum
O	Oxidizer
OC	Oxidizer pump calculated
OF	Outlet fuel pump
OFIS	Outlet fuel pump isentropic
OM	Oxidizer measured
OO	Oxidizer outlet
PF	Pump fuel
PO	Pump oxidizer
PUVO	Propellant utilization valve oxidizer
RNC	Ratio bypass nozzle, critical
SC	Specific, thrust chamber
SCV	Specific thrust chamber, vacuum
SE	Specific, engine
SEV	Specific, engine vacuum
T	Total
T _o	Turbine oxidizer
TEF	Turbine exit fuel
TEFS	Turbine exit fuel (static)
TF	Fuel turbine
TIF	Turbine inlet fuel (total)
TIFM	Turbine inlet, fuel, measured
TIFS	Turbine inlet fuel isentropic
TIO	Turbine inlet oxidizer
t	Throat
V	Vacuum
v	Valve
XF	Fuel tank repressurant
XO	Oxidizer tank repressurant

PERFORMANCE PROGRAM EQUATIONS

MIXTURE RATIO

Engine

$$r_E = \frac{W_{EO}}{W_{EF}}$$

$$W_{EO} = W_{OM} - W_{XO}$$

$$W_{EF} = W_{FM} - W_{XF}$$

$$W_E = W_{EO} + W_{EF}$$

Thrust Chamber

$$r_C = \frac{W_{CO}}{W_{CF}}$$

$$W_{CO} = W_{OM} - W_{XO} - W_{GO}$$

$$W_{CF} = W_{FM} - W_{XF} - W_{GF}$$

$$W_{XO} = 0.8 \text{ lb/sec}$$

$$W_{XF} = 1.8 \text{ lb/sec}$$

$$W_{GO} = W_T - W_{GF}$$

$$W_{CF} = \frac{W_T}{1 + r_G}$$

$$W_T = \frac{P_{TIF} A_{TIF} K_7}{TC * TIF}$$

$$K_7 = 32.174$$

$$W_C = W_{CO} + W_{CF}$$

CHARACTERISTIC VELOCITY

Thrust Chamber

$$C^* = \frac{K_7 P_c A_t}{W_C}$$

$$K_7 = 32.174$$

DEVELOPED PUMP HEAD

Flows are normalized by using the following inlet pressures, temperatures, and densities.

$$P_{IO} = 39 \text{ psia}$$

$$P_{IF} = 30 \text{ psia}$$

$$\rho_{IO} = 70.79 \text{ lb/ft}^3$$

$$\rho_{IF} = 4.40 \text{ lb/ft}^3$$

$$T_{IO} = -295.212^\circ\text{F}$$

$$T_{IF} = -422.547^\circ\text{F}$$

Oxidizer

$$H_O = K_4 \left(\frac{P_{OO}}{\rho_{OO}} - \frac{P_{IO}}{\rho_{IO}} \right)$$

$$K_4 = 144$$

$$\rho = \text{National Bureau of Standards Values } f(P, T)$$

Fuel

$$H_f = 778.16 \Delta h_{OFIS}$$

$$\Delta h_{OFIS} = h_{OFIS} - h_{IF}$$

$$h_{OFIS} = f(P, T)$$

$$h_{IF} = f(P, T)$$

PUMP EFFICIENCIES**Fuel, Isentropic**

$$\eta_f = \frac{h_{OFIS} - h_{IF}}{h_{OF} - h_{IF}}$$

$$h_{OF} = f(P_{OF}, T_{OF})$$

Oxidizer, Isentropic

$$\eta_O = \eta_{OC} Y_O$$

$$\eta_{OC} = K_{40} \left(\frac{Q_{PO}}{N_O} \right)^2 + K_{50} \left(\frac{Q_{PO}}{N_O} \right) + K_{60}$$

$$K_{40} = 5.0526$$

$$K_{50} = 3.8611$$

$$K_{60} = 0.0733$$

$$Y_O = 1.000$$

TURBINES

Oxidizer, Efficiency

$$\eta_{TO} = \frac{B_{TO}}{B_{ITO}}$$

$$B_{TO} = K_5 \frac{W_{PO} H_O}{\eta_O}$$

$$K_5 = 0.001818$$

$$W_{PO} = W_{OM} + W_{PUVO}$$

$$W_{PUVO} = \sqrt{\frac{Z_{PUVO} \rho_{OO}}{R_v}}$$

$$Z_{PUVO} = A + B (P_{OO})$$

$$A = -1597$$

$$B = 2.3828$$

$$\text{IF } P_{OO} \geq 1010 \text{ Set } P_{OO} = 1010$$

$$\ln R = A_3 + B_3 (\theta_{PUVO}) - C (\theta_{PUVO})^3 + D_3 (e)^{\frac{\theta_{PUVO}}{7}} \\ + E_3 (\theta_{PUVO}) (e)^{\frac{\theta_{PUVO}}{7}} + F_3 \left[(e)^{\frac{\theta_{PUVO}}{7}} \right]^2$$

$$A_3 = 5.5659 \times 10^{-1}$$

$$B_3 = 1.4997 \times 10^{-2}$$

$$C_3 = 7.9413 \times 10^{-6}$$

$$D_3 = 1.2343$$

$$E_3 = -7.2554 \times 10^{-2}$$

$$F_3 = 5.0691 \times 10^{-2}$$

Fuel, Efficiency

$$\eta_{TF} = \frac{B_{TF}}{B_{ITF}}$$

$$B_{ITF} = K_{10} \Delta h_f W_T$$

$$\Delta h_f = h_{TIF} - h_{TEF}$$

$$B_{TF} = B_{PF} = K_5 \left(\frac{W_{PF} H_f}{\eta_f} \right)$$

$$W_{PF} = W_{FM}$$

$$K_{10} = 1.4148$$

$$K_5 = 0.001818$$

Oxidizer, Developed Horsepower

$$B_{TO} = B_{PO} - K_{56}$$

$$B_{PO} = K_5 \frac{W_{PO} H_O}{\eta_O}$$

$$K_{56} = -15$$

Fuel, Developed Horsepower

$$B_{TF} = B_{PF}$$

$$B_{PF} = K_5 \frac{W_{PF} H_f}{\eta_f}$$

$$W_{PF} = W_{FM}$$

Fuel, Weight Flow

$$W_{TF} = W_T$$

Oxidizer Weight Flow

$$W_{TO} = W_T - W_B$$

$$W_B = \left[\frac{2K_7 H_2}{\gamma_{H_2-1}} (P_{RNC})^{\frac{2}{\gamma_{H_2}}} \right]^{\frac{1}{2}} \left[1 - (P_{RNC})^{\frac{\gamma_{H_2}-1}{\gamma_{H_2}}} \right] \frac{A_{NB} P_{BNI}}{(R_{H_2} T_{BIR})^{\frac{1}{2}}}$$

$$P_{RNC} = f(\beta_{NB}, \gamma_{H_2})$$

$$\beta_{NB} = \frac{D_{NB}}{D_B}$$

$$\gamma_{H_2} \cdot M_{H_2} = f(T_{H_2R}, R_G)$$

$$A_{NB} = K_{13} D_{NB}$$

$$K_{13} = 0.7854$$

$$T_{BIR} = T_{TIO} + 460$$

$$P_{BNI} = P_{TEFS}$$

$$P_{TEFS} = \text{Iteration of } P_{TEF}$$

$$P_{TEF} = P_{TEFS} \left[1 - K_8 \left(\frac{W_T}{P_{TEFS}} \right)^2 \frac{T_{H_2R}}{D_{TEF}^4 M_{H_2}} \left(\frac{\gamma_{H_2}-1}{\gamma_{H_2}} \right) \right]^{\frac{\gamma_{H_2}}{\gamma_{H_2}-1}}$$

$$K_8 = 38.8983$$

GAS GENERATOR**Mixture Ratio**

$$r_G = D_1 (T_{H1})^3 + C_1 (T_{H1})^2 + B_1 (T_{H1}) + A_1$$

$$A_1 = 0.2575$$

$$B_1 = 5.586 \times 10^{-4}$$

$$C_1 = -5.332 \times 10^{-9}$$

$$D_1 = 1.1312 \times 10^{-11}$$

$$T_{H1} = T_{TIFM}$$

Flows

$$TC^*_{TIF} = D_2 (T_{H1})^3 + C_2 (T_{H1})^2 + B_2 (T_{H1}) + A_2$$

$$A_2 = 4.4226 \times 10^3$$

$$B_2 = 3.2267$$

$$C_2 = -1.3790 \times 10^{-3}$$

$$D_2 = 2.6212 \times 10^{-7}$$

$$P_{TIF} = P_{TIFS} \left[1 + K_8 \left(\frac{W_T}{P_{TIFS}} \right)^2 \frac{T_{HIR}}{D^4_{TIF} M_{H1}} \frac{Y_{H1} - 1}{Y_{H1}} \right]^{\frac{Y_{H1}}{Y_{H1} - 1}}$$

$$K_8 = 38.8983$$

Note: P_{TIF} is determined by iteration.

$$T_{HIR} = T_{TIF}$$

$$M_{H1}, Y_{H1}, C_p, r_{H1} = f(T_{HIR}, r_G)$$

UNCLASSIFIED

Security Classification

DOCUMENT CONTROL DATA - R & D

(Security classification of title, body of abstract and indexing annotation must be entered when the overall report is classified)

1. ORIGINATING ACTIVITY (Corporate author) Arnold Engineering Development Center ARO, Inc., Operating Contractor Arnold Air Force Station, Tennessee	2a. REPORT SECURITY CLASSIFICATION UNCLASSIFIED
	2b. GROUP N/A

3. REPORT TITLE
ALTITUDE DEVELOPMENTAL TESTING OF THE J-2 ROCKET ENGINE IN PROPULSION ENGINE TEST CELL (J-4) (TESTS J4-1801-37 AND 38)

4. DESCRIPTIVE NOTES (Type of report and inclusive dates)
April 16 and 23, 1968 - Interim Report

5. AUTHOR(S) (First name, middle initial, last name)
C. E. Pillow, ARO, Inc.

6. REPORT DATE October 1968	7a. TOTAL NO. OF PAGES 151	7b. NO OF REFS 4
---------------------------------------	--------------------------------------	----------------------------

8a. CONTRACT OR GRANT NO. F40600-69-C-0001 b. PROJECT NO. 9194 c. System 921E d.	9a. ORIGINATOR'S REPORT NUMBER(S) AEDC-TR-68-201
	9b. OTHER REPORT NO(S) (Any other numbers that may be assigned this report) N/A

10. DISTRIBUTION STATEMENT **Each transmittal of this document outside the Department of Defense must have prior approval of NASA, Marshall Space Flight Center (I-E-J), Huntsville, Alabama.**

11. SUPPLEMENTARY NOTES Available in DDC.	12. SPONSORING MILITARY ACTIVITY NASA, Marshall Space Flight Center (I-E-J), Huntsville, Alabama
---	--

13. ABSTRACT
Eight firings and two partial transition tests of the J-2 rocket engine were accomplished during test periods J4-1801-37 and 38. These tests periods were conducted on April 16 and 23, 1968, respectively. Each of these firings was in support of the S-V/S-IVB stage engine to investigate engine start transients for first burn and restart simulations. The partial transition tests were to evaluate thrust chamber temperature effects on the engine start transients. All objectives were successfully met with a total accumulated firing duration of 156.6 sec.

~~This document is subject to special export controls and each transmittal to foreign governments or foreign nationals may be made only with prior approval of NASA, Marshall Space Flight Center (I-E-J), Huntsville, Alabama.~~

This document has been approved for public release
its distribution is unlimited. *RWA F Letter at 12 July. Signed William O. Cole*

14. KEY WORDS	LINK A		LINK B		LINK C	
	ROLE	WT	ROLE	WT	ROLE	WT
<p>J-2 rocket engines liquid propellants altitude simulation flight simulation thrust chamber temperature performance tests performance evaluation</p> <p>1. Rocket motors -- J-2. 2 " " " " --- Performance 3 " " " " -- Ignition 4 " " " " -- Restarting</p> <p>16-3.</p>						