

UNCLASSIFIED

AD NUMBER

AD845173

LIMITATION CHANGES

TO:

Approved for public release; distribution is unlimited.

FROM:

Distribution authorized to U.S. Gov't. agencies and their contractors;  
Administrative/Operational Use; 31 JUL 1968.  
Other requests shall be referred to Office of the Adjutant General (Army), Washington, DC 20310.

AUTHORITY

AGO ltr 29 Apr 1980

THIS PAGE IS UNCLASSIFIED

THIS REPORT HAS BEEN DELIMITED  
AND CLEARED FOR PUBLIC RELEASE  
UNDER DOD DIRECTIVE 5200.20 AND  
NO RESTRICTIONS ARE IMPOSED UPON  
ITS USE AND DISCLOSURE.

DISTRIBUTION STATEMENT A

APPROVED FOR PUBLIC RELEASE;  
DISTRIBUTION UNLIMITED.

# DISCLAIMER NOTICE

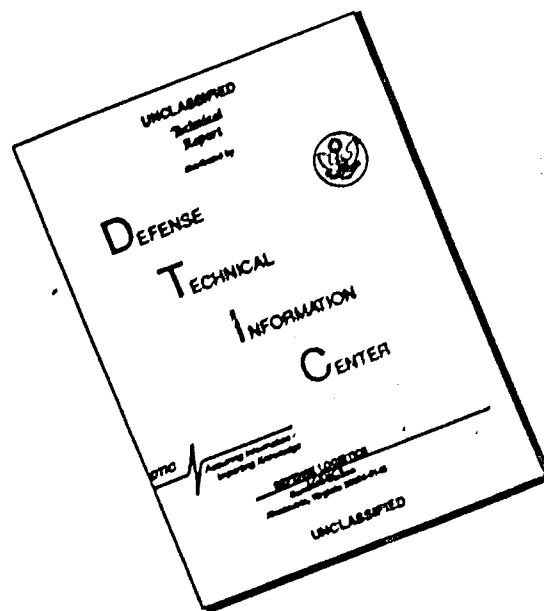

THIS DOCUMENT IS BEST QUALITY AVAILABLE. THE COPY FURNISHED TO DTIC CONTAINED A SIGNIFICANT NUMBER OF PAGES WHICH DO NOT REPRODUCE LEGIBLY.

FOR OFFICIAL USE ONLY



DEPARTMENT OF THE ARMY  
OFFICE OF THE ADJUTANT GENERAL  
WASHINGTON, D.C. 20310

IN REPLY REFER TO

AGAM-P (M) (10 Dec 68) FOR OT UT 683081 12 December 1968

SUBJECT: Operational Report - Lessons Learned, Headquarters, 19th Engineer Battalion (Combat)(Army), Period Ending 31 July 1968

SEE DISTRIBUTION

1. Subject report is forwarded for review and evaluation in accordance with paragraph 5b, AR 525-15. Evaluations and corrective actions should be reported to ACSFOR OT UT, Operational Reports Branch, within 90 days of receipt of covering letter.
2. Information contained in this report is provided to insure that the Army realizes current benefits from lessons learned during recent operations.
3. To insure that the information provided through the Lessons Learned Program is readily available on a continuous basis, a cumulative Lessons Learned Index containing alphabetical listings of items appearing in the reports is compiled and distributed periodically. Recipients of the attached report are encouraged to recommend items from it for inclusion in the Index by completing and returning the self-addressed form provided at the end of this report.

BY ORDER OF THE SECRETARY OF THE ARMY:

KENNETH G. WICKHAM  
Major General, USA  
The Adjutant General

1 Incl  
as

DISTRIBUTION:

- Commanding Generals
  - US Continental Army Command
  - US Army Combat Developments Command
- Commandants
  - US Army Command and General Staff College
  - US Army Engineer School
- Copies furnished:
  - Office, Chief of Staff, US Army
  - Deputy Chiefs of Staff
  - Chief of Engineers
  - Chief of Research and Development

D D C  
RECEIVED  
DEC 30 1968

UNCLASSIFIED REPORT

DISTRIBUTION NO FOREIGN WITHOUT APPROVAL OF  
ASSISTANT CHIEF OF STAFF FOR FORCE DEVELOPMENT  
(ARMY) ATTN FOR OT RD. WASHINGTON, D.C. 20310

AD845173

Protective marking cancelled when  
separated from inclosure.

FOR OFFICIAL USE ONLY

# FOR OFFICIAL USE ONLY

DEPARTMENT OF THE ARMY  
HEADQUARTERS 19TH ENGINEER BATTALION (COMBAT)(ARMY)  
APO San Francisco 96238

EGACBU-3

31 July 1968

SUBJECT: Operational Report Lessons Learned (HCS CSFOR-65), for Quarterly Period Ending 31 July 1968.

THRU: Commanding Officer, 35th Engineer Group (Const), APO 96238

Commanding General, 18th Engineer Brigade, ATTN: AVBC-C,  
APO 96377

Commanding General, United States Army, Vietnam, ATTN: AVHGC  
(DST), APO 96307

Commander in Chief, United States Army, Pacific, ATTN: GPOP-DT,  
APO 96588

TO: Assistant Chief of Staff for Force Development Department of the  
Army (ACSFOR-DA), Washington, D.C. 20310

## SECTION I, Operations: Significant Activities.

### 1. Command:

a. During the reporting period (May 1968 through July 1968), the 19th Engineer Battalion (C)(A) has continued its primary mission of upgrading QL-1 to MACV standards from Bong Son to Mo Duc; and its operational support mission of road maintenance on QL-1 from Phu Cat to Bong Son. The battalion continued its non-divisional engineer support within its AOR to the AMERICAL Division and to the 173rd Airborne Brigade. Also, provided was operational support to the 40th ARVN Regiment.

b. The 19th Engineer Battalion (C)(A), organized under TOE 5-35E consists of HHC and four (4) line companies. Attached are the 137th Engineer Company (LE), the 73rd Engineer Company (CS), and the 70th Engineer Company (DT). The 35th Engineer Battalion (CBT) Land Clearing Team was attached on 26 July 1968 for operational control.

c. The Battalion Headquarters, A Company, and the 137th Engineer Company (LE) are operating from LZ English North (Camp Schook)(BS 883056); C Company, 73rd Engineer Company (CS), and 70th Engineer Company (DT) are operating from LZ Lowboy(BS 913147);

**FOR OT AT**  
**683081** Incl 1

**FOR OFFICIAL USE ONLY**

EGACHE-3

31 July 1968

**SUBJECT: Operational Report Lessons Learned (RCS CSFOR-65) for Quarterly Period Ending 31 July 1968.**

D Company is operating from LZ Thunder (BS 868318), and B Company is operating from LZ Max (BS 763472). The 35th Engineer Battalion (CBT) Land Clearing Team is operating from LZ Uplift (BR 923750).

**2. Personnel, Administration, Morale, and Discipline.**

- a. There were 12 re-enlistments in the battalion during this quarter.
- b. During the period, 66 new personnel were assigned to the battalion and 69 personnel rotated.
- c. 22 Special Court-Martials and 1 Summary Court-Martial were conducted during this period.

**3. Intelligence and Counter Intelligence.**

a. During this reporting period, the reconnaissance section of the S-2 completed a special reconnaissance by vehicle to determine land clearing requirements on QL-1 from LZ English (BS 879006) to Phu My (BR 900674). A bridge and route inspection trip was made from the Bong Son River (BR 872958) south to Phu My to update 18th Engineer Brigade's II CTZ Bridge and Route Data, dated 1 April 1968. A weekly reconnaissance of this area is now conducted to check the condition of bridges and culverts. An airfield reconnaissance was performed at LZ Bronco in Duc Pho to determine requirements for repair of damaged and worn portions of the field. Total mileage of reconnaissance for this period was 88.5 miles.

b. The intelligence collection and dissemination efforts of the section were augmented by receipt of daily intelligence summaries from the 173rd Airborne Brigade and the 11th Light Infantry Brigade. Intelligence agent reports which might affect elements of the battalion were gathered from MACV advisors in Ho Duc, Duc Pho, and Hoi Nhon along with agent reports from elements of the 172nd and 52nd Military Intelligence Detachments giving us a comprehensive study of enemy activity throughout our area of operation.

c. There were a total of 300 enemy contacts for this period:

(1) On two (2) occasions VC sappers removed 710 LF of treadway from bridge QL1-403.

(2) Elements of the battalion were fired on by enemy small arms, automatic weapons, and grenades in 70 separate incidents.

EGACHE-3

31 July 1968

SUBJECT: Operational Report Lessons Learned (RCS CSFOL-65), for Quarterly Period Ending 31 July 1968.

(3) Mine sweep teams and work crews were caught in 10 ambushes initiated by the enemy armed with various small arms and automatic weapons.

(4) Equipment, vehicles, and personnel detonated a total of 23 mines and booby trap devices ranging anywhere in size from an M-14 anti-personnel mine to a pressure detonated 75 pound bulk explosive charge.

(5) The company mine sweep teams detected 38 mines and booby traps along with several detonating devices on Route QL-1 in the battalion's area of operation during this period.

(6) The VC constructed 32 obstacles on QL-1 for the purpose of harassment. These obstacles consisted of hand dug trenches, barricades of palm logs, barbed wire, piles of rocks, and other debris. The majority of these obstacles were booby trapped.

(7) The enemy destroyed 22 culverts by placing large explosive charges or artillery rounds inside or directly on top of the culvert.

(8) Elements of the battalion received mortar fire, rockets, and satchel charges in 8 different incidents.

(9) VC psychological warfare efforts resulted in 20 cases of propaganda aimed at the withdrawal of American Forces from Vietnam. Literature varied from handwritten misspelled statements to printed pamphlets with a definite ideological meaning.

(10) At the end of the last period, the battalion's Voluntary Informant Program was discontinued due to the lack of sufficient funds to meet heavy requirements at that time. However, it is once again reactivated since funds are now available both from the 52nd Military Intelligence Detachment at LZ Bronco and from the 18th Engineer Brigade. The following items have been turned in by the local Vietnamese since the program was reactivated on 6 June 1968:

81mm Mortar rounds	1 ea
97mm Recoilless rifle rounds	12 ea
60mm Mortar rounds	5 ea
155mm Artillery rounds	1 ea
105mm Artillery rounds	3 ea
	3

EGACHE-3

31 July 1968

SUBJECT: Operational report Lessons Learned (HCS CSFOR-65), for Quarterly Period Ending 31 July 1968.

M-72 LAW	1 ea
M-26 Frag grenades	9 ea
M-79 40mm rounds	14 ea
M-18A1 Claymore mine	1 ea
5.56mm Rounds	20 ea
M-16 Magazine	1 ea
Electric firing wire	200 ft

Total expenditures from 6 June 1968, for the above mentioned items was 6,200 \$VN.

(11) The battalion apprehended 6 suspicious Vietnamese who were turned over to local infantry units for interrogation.

(12) Casualties resulting from these incidents to the battalion and attached units were 17 US KIA and 53 US WIA.

#### 4. Plans, Operation and Training.

a. During the reporting period, elements of the battalion spent 85 days on LOC upgrading and operational support, and 7 days on training.

b. The battalion has continued its upgrading of QL-1 to MACV standard roadway by the construction of a 300' timber pile bridge (which is 98% complete), a 102' steel stringer bridge (which is 33% complete), and 11 culverts (these either replace destroyed bridges or existing bridges), and widening of the existing roadway. 10,532 cu yds of sand was hauled to widen and stabilize the right-of-way for the road. 220,989 cu yds of laterite was hauled for subgrade fill. 7,589 cu yds of blast rock was utilized for stabilization. 25,629 cu yds of 2 $\frac{1}{2}$ "(-) rock was utilized as base course material covering 10,634 yds with a 6" lift of rock.

c. During the quarter twenty-nine (29) masonry and concrete headwalls were constructed at existing culverts and newly constructed ones. 3,095' of 60" culvert, 1,423' of 48" culvert, 1,462' of 36" culvert, and 1,217' of 24" culvert were used for drainage.

d. Maintenance effort along QL-1 involved repairing existing bridging and drainage, re-cutting ditches, cleaning out culverts, and filling pot-holes. Twenty-two (22) culverts have been replaced as the results of enemy sabotage.

EGACBE-3

31 July 1968

SUBJECT: Operational Report Lessons Learned (RCS CSFOR-65), for Quarterly Period Ending 31 July 1968.

e. Besides providing equipment support for road and bridge building, the 137th Engineer Company (LE) has continued its tasks of laying the base course rock and applying an asphalt seal coat on QL-1. 25,629 cu yds of 2½"(-) crushed rock was placed and compacted in a 6" lift covering a linear distance of 10,634 yds. 16.7 miles of asphalt seal coat was applied.

f. The 73rd Engineer Company (CS) has continued its operations of the heavy construction support facility, consisting of two (2) 75 TPH primary and two (2) 75 TPH secondary rock crushers. Production during the quarter yielded 32,866 cu yds of 2½"(-) rock, 1,803 cu yds of 1" rock, 4,330 cu yds of ¾" rock, and 6,420 cu yds of ½"(-) rock. 73,000 LBS of explosives was used in the quarry operations. Also, the asphalt plant went into production on 29 June 1968 and during the quarter produced 5,957 tons of asphalt. 5.3 miles of QL-1 was paved with a 2½" lift, 24' wide roadway.

g. Major operational support was provided on the following projects:

(1) Operation of water points. The 19th has continued to operate two (2) water points at Bong Son River (relocated to LZ English on 2 Aug 68), and one (1) water point at QL1-399 for support of units in the battalion AOR. An average of 40,000 gals of potable water is dispensed per day.

(2) Daily repair of the airfield runway and aprons at LZ English was performed by welding the M8A1 matting.

(3) Constructing Artillery Pads: Four (4) wooden artillery firing pads are being constructed at LZ Pony (BR 798833). 3 pads are completed and the fourth is 75% complete.

(4) Hauled empty 55 gal asphalt drums to LZ Orange (BR 818883) for construction of revetment walls.

(5) Maintained the causeway at Bong Son River. Continuous road repair is conducted to keep the causeway open to traffic.

h. Direct support was provided to units within the battalion's AOR in the form of equipment, such as D-7E dozers, 16S concrete mixers, and 20-Ton rough terrain cranes. An estimated 350 acres of land was cleared by the Land Clearing Team for fields of fire and denial of concealment to the enemy.

i. In support of LOC upgrading and operational support missions this quarter, the battalion has hauled and compacted 220,989 cu yds of laterite, 10,532 cu yds of sand, operated four (4) 75 TPH rock crushers, (2 primary and 2 secondary) producing 45,419 cu yds of crushed rock,

31 July 1968

SUBJECT: Operational Report Lessons Learned (RCS CSFOh-65), for Quarterly Period Ending 31 July 1968.

placed base course on 85,072 sq yds of QL-1, operated an asphalt plant producing 5,957 tons of pavement, paved 5.3 miles of QL-1, assembled 7,197' of culvert, expended 415,000 BF of lumber, 10,500 bags of cement, and 17,680 lbs of nails and spikes.

#### 5. Logistics:

a. Shortages of critical construction materials and equipment is still a major problem. The following are the critical shortage items:

(1) Construction Materials:

6"x16"x29 timber stringers

(2) Equipment:

250 CFM Pneumatic Tool and Compressor set

Water Distribution Equipment

Compaction Equipment

b. A major problem is the long haul distance for supplies. Material is drawn from depots located in Qui Nhon, then transported sixty (60) miles to the battalion's S-4 yard, and finally transported to the various job sites. All construction materials, except asphalt, are transported by the battalion's own organic haul capability.

#### SECTION II. Lessons Learned: Commander's Observation, Evaluation, and Recommendations.

#### 1. Personnel.

##### a. Finance:

(1) OBSERVATION: Finance Data Record Folders are maintained at the 13th Finance, Qui Nhon Support Area, a distance of 70 miles from the Battalion Personnel Section. This required an individual to report to battalion for finance processing and then to return to the finance office for payment of travel pay and normal pay due.

(2) EVALUATION: Personnel are now processed at the Finance Office prior to reporting to battalion thru coordination with the 35th Engineer Group located at Qui Nhon. This saves numerous man hours traveling to and from the 13th Finance Section.

31 July 1968

SUBJECT: Operational Report Lessons Learned (RCS CSFOR-65), for Quarterly Period Ending 31 July 1968.

(3) RECOMMENDATION: Recommend that individuals being assigned to this battalion have their finance processing completed at the 13th Finance Section prior to reporting to battalion. Class "A" Agents should establish a pay complaint period immediately following pay call. Pay complaints can then be handled by the Class "A" Agent upon return of the payroll to the Finance Section.

b. Replacements.

(1) OBSERVATION: A critical shortage of senior NCO's in the past few months has required cross-training in some areas resulting in an increase of the responsibilities to the few NCO's assigned.

(2) EVALUATION: At present this unit is authorized 11 E-8. Presently assigned 4. 34 E-7, presently assigned 18. This has resulted in all assigned NCO's performing dual functions. This has an adverse effect upon the unit operations as areas requiring detailed and close supervision are not receiving it.

(3) RECOMMENDATION: That requirements for personnel of all grades be more carefully screened in order to insure that units are not brought below realistic operating levels to assure efficient and proper supervision as required.

2. Operations.

a. Culvert construction:

(1) OBSERVATION: Two large sections of 60" culverts are extremely difficult to fit together after being assembled and transported to the site.

(2) EVALUATION: When pre-assembled 60" culvert is transported to the job site, it has to be in lengths no greater than thirty (30) feet to be easily transported on a low-bed trailer. Problems are encountered when trying to assemble the two (2) sections at the job site.

(3) RECOMMENDATION: Prefit the culvert sections before transporting to job site by assembling one section two feet longer than the other. Upon completion, remove the two foot section and fit it on to the shorter section. In this manner, you have a prefitted culvert that will go together with ease on the site.

b. Spacing for multiple tube culverts.

(1) OBSERVATION: When preparing a site for a multiple culvert drainage structure the minimum distance considered between culvert tubes should be one half the diameter of the culvert material to be utilized.

31 July 1968

SUBJECT: Operational Report Lessons Learned (RCS CSFOR-65), for Quarterly Period Ending 31 July 1968.

In the past it has been found that a high explosive charge placed in a single culvert tube can cause extensive damage not only to the culvert tube but also to the adjacent tubes.

(2) EVALUATION: If construction of a multiple culvert drainage structure is to be in an area of frequent enemy interdiction, culvert tubes should be spaced a distance of twice the diameter of the culvert material to be used. By constructing the drainage structures in this manner, a high explosive charge placed in a particular culvert tube will only cause extensive damage to that tube. Utilization of this method will save many critical man hours and considerable amounts of materials in the future.

(3) RECOMMENDATION: When multiple culvert drainage structures are to be constructed in an area of frequent enemy interdiction, it is recommended that the minimum culvert spacing be twice the diameter of the culvert being utilized.

c. Reducing the time required to place multiple tube culvert.

(1) OBSERVATION: To prevent damage to more than one culvert by a single charge, multiple tube 48" and 60" culverts are being placed 2 times the diameter apart. Due to the large amount of fill required and the inaccessibility between culverts for compaction equipment, work is tedious and progress is slow.

(2) EVALUATION: By placing two continuous concrete footers up to the flanges on the culverts, you form enclosed areas around the culverts. Sand is used in lieu of laterite to the flanges and is used to fill to the depth that you can safely operate compaction equipment over the culverts, which are reinforced by struts.

(3) RECOMMENDATION: Using this method of placing culverts will cut down completion time considerably and will prevent erosion around the tubes.

d. Increasing retention of rock crusher fines.

(1) OBSERVATION: During crushing operations, it was discovered that a large percentage of fines (material that passes through 200 sieve, and the most valuable ingredient in the production of asphalt) was being lost to the wind and atmosphere.

(2) EVALUATION: It was theorized that a fine spray of water just before or at the areas of dust turbulence would reduce the loss of the fine particles. Areas of turbulence would be any area where the crushed rock is dropped through the air or is vibrated.

31 July 1968

SUBJECT: Operational Report Lessons Learned (RCS CSFOR-65), for Quarterly Period Ending 31 July 1968.

(3) RECOMMENDATION: A sprinkler system was constructed to wet the fines at the points of turbulence. A 4000 gallon water tank was placed near the crusher and elevated enough to produce 70' of head. The tank was connected to a manifold, and connected to it were four (4) pieces of rubber hose which had the ends blocked and were perforated. The hoses were placed inside the exit chute of the secondary crusher. The resulting fine spray of water wets the fines enough to prevent them from being lost in the air, but not enough to cause them to stick to the coarse particles and clog the screens. This method has resulted in a 25% increase in the fines retained on the  $\frac{1}{2}$ "(-) pile.

e. French drainage for wells located near the roadway.

(1) OBSERVATION: Vietnamese water wells on or near roadways, after normal usage and spillage, create pools or puddles, which will saturate the sub base and/or base course of the road causing soft spots.

(2) EVALUATION: To compensate for this puddling near the roadway in areas of a uniform elevation such as the Coastal Plains, where natural or man-made drainage does not suffice or will not carry the water away from the road, it has been found that French Drains are extremely effective. The size of the drain to be constructed is based on the usage and traffic, for any particular well. The normal depth and size of drains constructed, that have been found sufficient, is a pit 8'x8', filled with blast rock or similar material, to a height of 5' to 6' with a tube or pipe leading into the upper 2' of rock. Then the pit is backfilled and a ditch constructed to carry the flow of water from the well to the French Drain. This ditch can be concrete lined or left natural depending on soil characteristics.

(3) RECOMMENDATION: That in areas where man-made structures and uniform elevation do not allow for drainage of pools and puddles, drains similar to this should be constructed. These provide a means of carrying water from the roadway and speeds up the seepage in that water follows the path of least resistance.

f. rock claw.

(1) OBSERVATION: A great deal of time is lost in rock crushing operations utilizing the 75 TPH Eagle Rock Crusher with its small 20x36 inch jaw due to oversized rocks jamming the jaw. The time lost in extracting these rocks easily adds up to a substantial loss in time over an operating day.

(2) EVALUATION: The three (3) places to catch oversized rock are; (1) during loading of haul trucks, (2) in the primary charging hopper, (3) and in the jaw itself.

31 July 1968

SUBJECT: Operational Report Lessons Learned (RCS CSFOR-65), for Quarterly Period Ending 31 July 1968.

Careful crane operation will serve to make maximum use of the first. Of the last two, it is easier by far to remove the rocks from the hopper. Large rocks will work themselves to an accessible location as they accessibly move along the apron feeder toward the scalper. They can be lifted out of the hopper with a rock claw. Should they get to the jaws, they can be lifted out with a simple sling. Lifting can be accomplished by using a crane or a vehicle mounted "A" frame.

(3) RECOMMENDATION: A two piece rock claw can be constructed that one man can handle and that can easily be dropped into position over any reasonably sized rocks. Its own weight will secure the rock most firmly, allowing safe and swift lifting. A hook on one arm will provide for the use of a sling over the jaws without removal of the rock claw from the main lifting hook. Construction can be as shown in the accompanying sketch attached.

g. Protection for D-7E blade tilt cylinder.

(1) OBSERVATION: While supporting quarry operations continual down time has been experienced due to broken or damaged hydraulic lines leading to blade tilt cylinder.

(2) EVALUATION: This down time is inherent because of line connectors being located on the bottom of the cylinder. This location, though there is a guard, affords the opportunity for rocks which roll around the blade to continually strike the guard causing it to become damaged and consequently damaging the lines and connectors.

(3) RECOMMENDATION: The cylinder can be disconnected from the push beam by removing the pin and rotating the cylinder 180°, thus placing the cylinder connectors and lines on top. This modification will give entire use without the repeated down time, leaving only normal operational break downs and deadline services.

3. Training: None

4. Intelligence.

a. Probing suspected mine locations.

(1) OBSERVATION: Probing for suspected electrically detonated mines should be done with a probe made of a non-conductive material.

(2) EVALUATION: A bayonet or any other metal object used for probing will complete the triggering circuit of an electrically detonated mine when passing over or through the wires. This conduction only exists when a mine has its own power source. However, this cannot be determined prior to probing.

31 July 1968

SUBJECT: Operational Report Lessons Learned (ICS CSFOR-65), for Quarterly Period Ending 31 July 1968.

(3) RECOMMENDATION: Use a piece of bamboo that has been sharpened to a fine point. If it should contact any part of the trigger circuit, it will not complete the circuit.

b. Handling ammunition and explosives turned in by Vietnamese.

(1) OBSERVATION: Extreme care should be taken not to let anyone fire the ammunition or utilize the explosives captured or turned-in by the Vietnamese.

(2) EVALUATION: There have been incidents where the ammunition has been altered or the explosives rigged to go off prematurely.

(3) RECOMMENDATION: Always dispose of these items by either blowing with explosives or burning.

5. Logistics.

a. PLL for new equipment.

(1) OBSERVATION: This unit received four (4) new Letournau-Westinghouse graders without PLL which resulted in unnecessary down time due to a lack of repair parts.

(2) EVALUATION: This down time could have been eliminated or greatly reduced if a PLL had been received with the graders when they were received.

(3) RECOMMENDATION: PLL be procured by depots for new equipment in the Army inventory before the equipment is sent to units and the PLL accompany each piece of equipment when it is shipped overseas.

6. Organization.

a. Mail clerks.

(1) OBSERVATION: Two mail clerks of higher grade (1 E-5 and 1 E-4) are required for isolated units.

(2) EVALUATION: Due to stringent personnel requirements and distances traveled between this and higher headquarters, the mail clerk is, of necessity, also acting as a courier. This involves travel over distances in excess of 150 miles, over non-secure roads on a daily basis. Since the road is non-secure a "shotgun" is required in order to adequately insure the safety of both mail and distribution, which affects both the morale and operations of this battalion. Further, since travel and pick-up consumes the entire day, this results in a daily backlog of insured and redirected mail requiring two (2) personnel to handle. The time for travel cannot be reduced significantly due to road traffic conditions.

31 July 1968

SUBJECT: Operational Report Lessons Learned (RCS CSFOR-65), for Quarterly Period Ending 31 July 1968.

In addition, the nature of the position is such that the authorized grade of E-3 does not provide for either the required skill or the required sense of importance and responsibility.

(3) RECOMMENDATION: Two (2) mail clerks would insure elimination of the backlog of redirected and insured mail while the increase of grade would insure the required job skill and sense of responsibility to the position.

#### 7. Maintenance.

##### a. Safe removal of propeller shaft on 5-Ton and 2½-Ton trucks.

(1) OBSERVATION: Frequent safety problems have been encountered with the 5-Ton and 2½-Ton trucks in this unit while attempting to remove the propeller shaft, which is mounted between the transfer case and transmission. Apparently the sprague unit in the transfer case has an excessive amount of torque built up in one direction.

(2) EVALUATION: Bodily injury can be inflicted to a mechanic while removing a propeller shaft, due to his unawareness of the wind up in the power train. As the 1st bolt in the propeller shaft is removed the propeller shaft will spin off possibly causing injury to the mechanic.

(3) RECOMMENDATION: When a vehicle power train is to be worked on, always lift one of the front wheels clear of the ground to release wind up from the power train. As soon as windup has been released, the necessary repairs can be accomplished.

##### b. Locking pins for D-7E scarifier teeth.

(1) OBSERVATION: Frequent problems have been encountered with the tractor, F.T. D-7E scarifier teeth. The teeth stay attached to the shank for a very short period of time when operating on extremely rough surfaces.

(2) EVALUATION: The loss of the tooth from the shank is caused by dislodging of the pin which attaches the tooth to the shank. Loss of the pin is caused by the vibration from the operation of the scarifier.

(3) RECOMMENDATION: The holes in the scarifier teeth should be enlarged to 11/16" diameter and the pins manufactured 6" long and 5/8" in diameter. Holes should be drilled 7/32" in diameter in each end of the pin, and 3/16" diameter cotter pins installed as locking devices. This will prevent the pin from slipping out, resulting in the loss of the tooth from the shank.

31 July 1968

SUBJECT: Operational Report Lessons Learned (RCS CSFOR-65), for Quarterly Period Ending 31 July 1968.

c. Apron feeder on the 75 TPH Eagle Crusher.

(1) OBSERVATION: Frequent breakage of the tailstock shaft on the 75 TPH Primary Eagle Rock Crusher has resulted in excessive down and dead-line time to effect repairs. Additionally, this shaft is not a normal stockage item with the result that replacements have to be machined. Need for a stronger shaft is indicated.

(2) EVALUATION: Original and replacement apron feeder tailstock shafts have repeatedly broken at the outside surface of the exterior star sprockets. The failure results in a clean breakage indicating a very high stress at the point in question. Alignment checks of the shaft bushings and the apron feeder proper have failed to point up the source of the error.

(3) RECOMMENDATION: It was discovered that early models of this crusher employed a shaft that was nominally 3.500 inches in diameter as opposed to the 2.500 inches in diameter of the shaft on the model presently used by this unit. The hubs of the star sprockets have ample material to allow them to be bored out to the larger dimension. Machining of an over-size shaft of a nominal size of 3.500 inches of high-carbon steel with the original size journal surfaces, and modification of the star sprockets to accommodate the new shaft, has resulted in a system that has had no failures to date. Therefore, replacement of the 2.500 inch shaft with the 3.500 inch shaft is indicated to prevent failure.

d. Vented dummy coupler for 5-Ton truck.

(1) OBSERVATION: Frequent problems have been encountered with the brake system on the M51A2, 5-Ton dumps, caused by not using a vented dummy coupling on the service air coupler.

(2) EVALUATION: Serious brake damage can be caused by not using a vented dummy coupler. If not detected early enough, it could be cause for major brake repair.

(3) RECOMMENDATION: When the vented dummy coupler is not available, the regular dummy coupler may be used with modification. To modify the coupler, an 1/8" hole is drilled in the center to allow the proper ventilation.

e. Field expedient air filter element for 250 CFM Air Compressor.

(1) OBSERVATION: The air filter element for the air compressor, 250 CFM, Davey Model M250RVP, had been used until it could no longer be cleaned for re-use. A check of all tech service sources showed that none were available in this area.

EGACBE-3

31 July 1968

SUBJECT: Operational Report Lessons Learned (RCS CSFOA-65), for Quarterly Period Ending 31 July 1968.

(2) EVALUATION: To wait for the replacement item to come in on a requisition would have meant many days of down-time. Searching for an expedient solution, we found that the air cleaner for a truck, dump, 6x6, 5-Ton, M51A2 will work. Cut down to proper size, the filament provides enough paper filament to fill the two elements required by the compressor. After replacing the filters, they registered "OK".

(3) RECOMMENDATION: Use only when unable to obtain the correct filters from supply system.

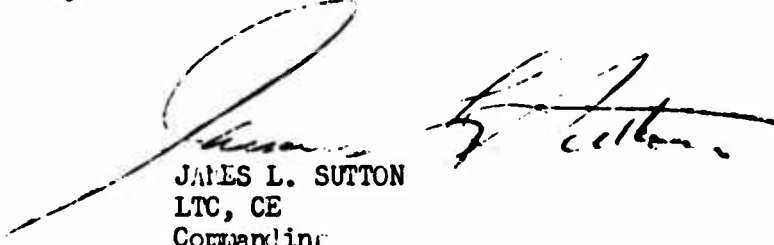

JAMES L. SUTTON  
LTC, CE  
Commanding

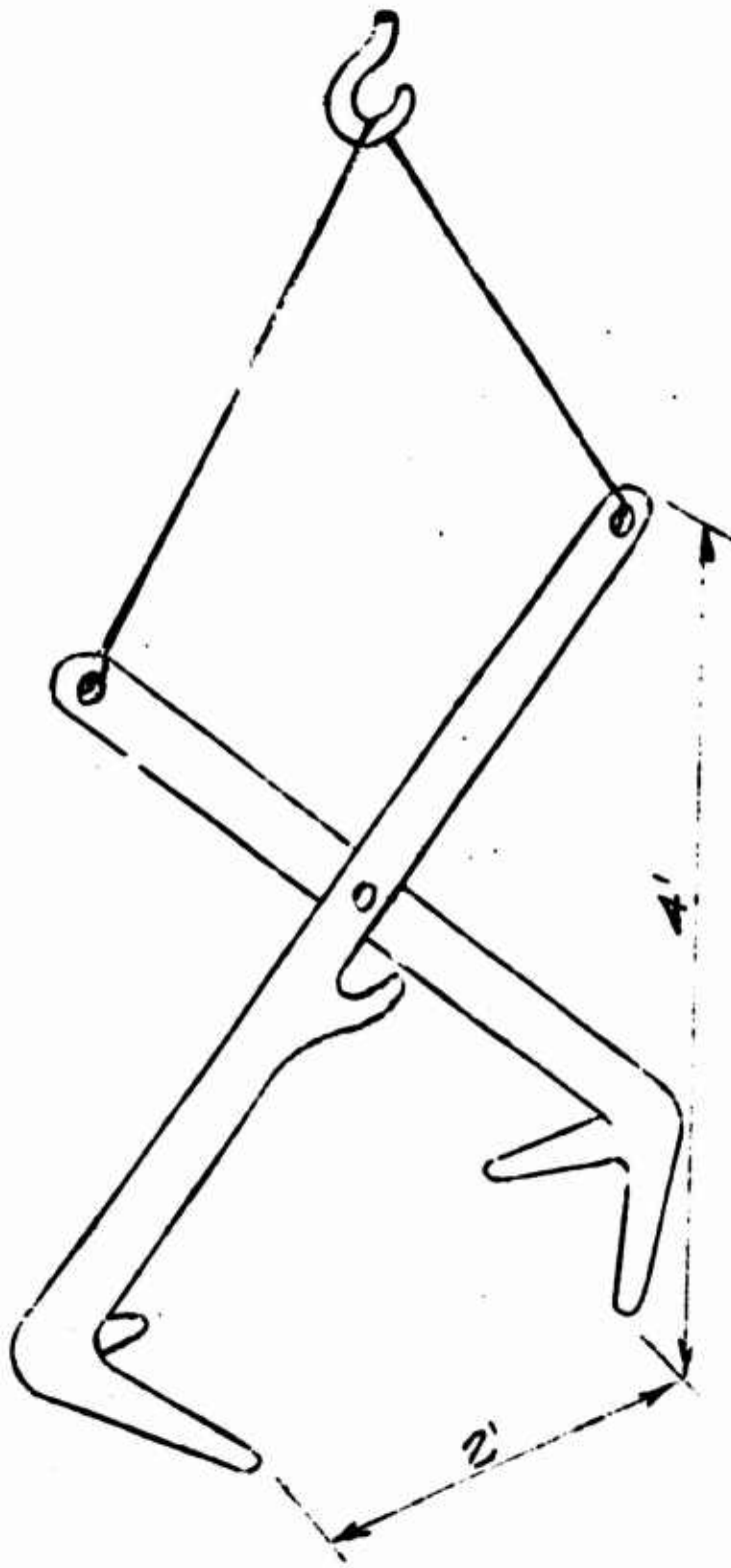

SKETCH OF ROCK CLAW  
SEE PARA. 2f(3)

15

## FOR OFFICIAL USE ONLY

EGA-3 (31 July 1968) 1st Ind

MAJ Pierce/3303

SUBJECT: Operational Report Lessons Learned (RCS CSFOR-65), for Quarterly Period Ending 31 July 1968.

DA, Headquarters, 35th Engineer Group (Const), APO 96238, 23 August 1968

TO: Commanding General, 18th Engineer Brigade, ATTN: AVBC-C, APO 96377

1. I have reviewed the Operational Report of the 19th Engineer Battalion (Construction) and consider it an accurate account of the Battalion's activities during the quarterly period ending 31 July 1968.

2. Concur with the comments and recommendations of the Battalion Commander with the following comments added:

a. Reference Section I, paragraph 2b. The numerical strength of the 19th Engineer Battalion increased slightly during the reporting period. On 31 July the Battalion was at 88.7% of its authorized strength, while the 73rd Engr Co (CS) and the 137th Engr Co (LE) were at 96.4% and 86.1% of authorized strengths, respectively.

b. Reference Section I, paragraph 5b. Although the need for timely delivery of construction materials will continue to require the utilization of the Battalion's organic haul capability, additional emphasis will be placed on assisting the unit to coordinate transportation requirements with the Director of Transportation, Qui Nhon Support Command.

c. Reference Section II, paragraph 1b. As indicated in the Report a critical shortage of Senior Combat Engineer NCO's does exist. This headquarters has, however, given the 73rd Engr Co (CS) and the 137th Engr Co (LE) priority for assignment of enlisted personnel resources to include NCO's to provide maximum support to the 19th Engineer Battalion.

d. Reference Section II, paragraph 7a. Raising a wheel to allow a power train to unwind is a normal procedure during removal of propeller shafts and is discussed in technical manuals for equipment with sprague units. Windup of the sprague unit is most commonly caused by the failure of the vehicle operator to shift into first gear after having travelled in reverse.

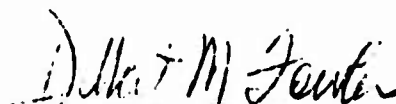
  
ROBERT M. FOWLER  
COL, CE  
Commanding

## FOR OFFICIAL USE ONLY

AVHC-C (31 Jul 68) 2nd Ind

SUBJECT: Operational Report of the 19th Engineer Battalion (Combat) for  
the Period Ending 31 July 1968, RCS CSFOR - 65 CR1

DA, Headquarters, 18th Engineer Brigade, APO 96377 4 SEP

TO: Commanding General, U.S. Army, Vietnam, ATTN: AVHCC-DST, APO 96375

1. This headquarters has reviewed the Operational Report - Lessons Learned for the 19th Engineer Battalion (Combat) as indorsed by the 35th Engineer Group. The report is considered to be an excellent account of the Battalion's activities for the reporting period.

2. This headquarters concurs with the observations and recommendations of the Battalion and Group Commanders with the following comments added: Reference Section II 6 a. The Battalion strength including attachments is 1212 men: AR 310-32 authorizes 1 mail clerk per 750 persons or major fraction thereof. Therefore, an increase in the number of mail clerks is warranted and will be considered during the next MTOE action.

*Douglas K. Blue*

DOUGLAS K. BLUE  
Colonel, CE  
Deputy Commander

AVHGC-DST (31 Jul 68) 3d Ind

MAJ Klingman/ds/IBN 4433

SUBJECT: Operational Report Lessons Learned (RCS CSFOR-65), for  
Quarterly Period Ending 31 July 1968

HEADQUARTERS, UNITED STATES ARMY, VIETNAM, APO San Francisco 96375 25 OCT 1968

TO: Commander in Chief, United States Army, Pacific, ATTN: GPDP-DT,  
APO 96558

1. This headquarters has reviewed the Operational Report-Lessons Learned for the quarterly period ending 31 July 1968 from Headquarters, 19th Engineer Battalion (Combat)(Army).

2. Reference item concerning mail clerks, page 11, Section II, paragraph 6a; and 2d Indorsement, paragraph 2. The unit will be advised that mail delivery clerks may be appointed on unit orders.

FOR THE COMMANDER:



A.R. GUENTHER  
CPL. AGC  
ASST. ADJUTANT GENERAL

Cy furn:  
HQ 18th Engr Bde  
HQ 19th Engr Bn (C)(A)

GPOP-DT (31 Jul 68) 4th Ind (U)

SUBJECT: Operational Report of HQ, 19th Engineer Battalion (Combat)(Army)  
for Period Ending 31 July 1968, RCS CSFOR-65 (R1)

HQ, US Army, Pacific, APO San Francisco 96558

3 DEC 1968

TO: Assistant Chief of Staff for Force Development, Department of the  
Army, Washington, D. C. 20310

This headquarters has evaluated subject report and forwarding indorsements  
and concurs in the report as indorsed.

FOR THE COMMANDER IN CHIEF:

*C.L. Short*

C.L. SHORT  
CPT, AGC  
Asst AG

UNCLASSIFIED

Security Classification

**DOCUMENT CONTROL DATA - R & D**

*(Security classification of title, body of abstract and indexing annotation must be entered when the overall report is classified)*

<b>1. ORIGINATING ACTIVITY (Corporate author)</b> HQ, OACSFOR, DA, Washington, D.C. 20310		<b>2a. REPORT SECURITY CLASSIFICATION</b> FOR OFFICIAL USE ONLY	
		<b>2b. GROUP</b> 4	
<b>3. REPORT TITLE</b> Operational Report - Lessons Learned, Headquarters, 19th Engineer Battalion(Combat) (Army) (U)			
<b>4. DESCRIPTIVE NOTES (Type of report and inclusive dates)</b> Experiences of unit engaged in counterinsurgency operations, 1 May - 31 July 1968			
<b>5. AUTHOR(S) (First name, middle initial, last name)</b> CO, 19th Engineer Battalion (Combat)			
<b>6. REPORT DATE</b> 31 July 1968	<b>7a. TOTAL NO. OF PAGES</b> 20	<b>7b. NO. OF REFS</b>	
<b>8a. CONTRACT OR GRANT NO.</b>	<b>8b. ORIGINATOR'S REPORT NUMBER(S)</b> 683081		
<b>8. PROJECT NO.</b> N/A	<b>8c. OTHER REPORT NO(S) (Any other numbers that may be assigned this report)</b>		
<b>10. DISTRIBUTION STATEMENT</b>			
<b>11. SUPPLEMENTARY NOTES</b> N/A		<b>12. SPONSORING MILITARY ACTIVITY</b> OACSFOR, DA, Washington, D.C. 20310	
<b>13. ABSTRACT</b>			

21

The following items are recommended for inclusion in the Lessons Learned Index:

ITEM 1

\* SUBJECT TITLE \_\_\_\_\_

\*\* FOR OT RD # \_\_\_\_\_

\*\*\*PAGE # \_\_\_\_\_

ITEM 2

SUBJECT TITLE \_\_\_\_\_

FOR OT RD # \_\_\_\_\_

PAGE # \_\_\_\_\_

ITEM 3

SUBJECT TITLE \_\_\_\_\_

FOR OT RD # \_\_\_\_\_

PAGE # \_\_\_\_\_

ITEM 4

SUBJECT TITLE \_\_\_\_\_

FOR OT RD # \_\_\_\_\_

PAGE # \_\_\_\_\_

ITEM 5

SUBJECT TITLE \_\_\_\_\_

FOR OT RD # \_\_\_\_\_

PAGE # \_\_\_\_\_

\* Subject Title: A short (one sentence or phrase) description of the item of interest.

\*\* FOR OT RD # : Appears in the Reply Reference line of the Letter of Transmittal. This number must be accurately stated.

\*\*\*Page # : That page on which the item of interest is located.