

UNCLASSIFIED

AD NUMBER

AD845768

LIMITATION CHANGES

TO:

Approved for public release; distribution is unlimited.

FROM:

Distribution authorized to U.S. Gov't. agencies and their contractors; Critical Technology; JAN 1969. Other requests shall be referred to Air Force Aero Propulsion Laboratory, Attn: APIP-2, Wright-Patterson AFB, OH 45433. This document contains export-controlled technical data.

AUTHORITY

AFAPL ltr, 12 Apr 1972

THIS PAGE IS UNCLASSIFIED

AD845768

---

# LARGE RETRACTABLE SOLAR CELL ARRAY

---

## SECOND QUARTERLY REPORT

JANUARY 1968

STATEMENT OF UNCLASSIFIED

This document is subject to special export controls and each transmittal to foreign governments or foreign nationals may be made only with prior approval of \_\_\_\_\_

PREPARED FOR

Air Force Aero Propulsion Laboratory  
Research and Technology Division  
Wright-Patterson Air Force Base, Ohio 45433

*attn: AP1P-2*

PROJECT NO. 68(2)/DATA NO. HS287-283(2)/CONTRACT NO. F33615-68-C-1676

PREPARED BY:

Hughes Aircraft Company / Space Systems Division  
(Under Contract F33615-68-C-1676)

AUTHORS:

E. O. Felkel

G. Wolff

Et al.

JAN 18 1968  
A

---

Hughes Ref No. 68(22)-10491/B3532-004

S8D 80533R

**BLANK PAGES  
IN THIS  
DOCUMENT  
WERE NOT  
FILMED**

---

# LARGE RETRACTABLE SOLAR CELL ARRAY

---

## SECOND QUARTERLY REPORT

JANUARY 1969

**PREPARED FOR**  
Air Force Aero Propulsion Laboratory  
Research and Technology Division  
Wright-Patterson Air Force Base, Ohio 45433

**PROJECT NO. 682J/DATA NO. HS207-205(2)/CONTRACT NO. F33615-68-C-1676**

●  
**PREPARED BY:**  
Hughes Aircraft Company / Space Systems Division  
(Under Contract F33615-68-C-1676)

**AUTHORS:**

E. O. Felkel  
G. Wolff  
Et al.

---

Hughes Ref No. 68(22)-10491/B3532-004

SSD 80533R

## FOREWORD

This report was prepared by Hughes Aircraft Company, Space Systems Division, El Segundo, California, under Contract No. F33615-68-C-1676. The work was administered under the direction of Mr. L. D. Massie, APIP-2, Air Force Aero Propulsion Laboratory.

This report covers work completed from 28 September to 27 December 1968. Contributors to this report include E. O. Felkel, G. Wolff, M. C. Olson, W. N. Turner, J. K. Hazen, R. E. Daniel, G. P. Steffen, L. R. McGlothlen, D. Plummer, and I. Wolff, all of Hughes Aircraft Company, Space Systems Division, El Segundo, California.

The work covered by this report was accomplished under Air Force Contract F33615-68-C-1676, but this report is being published and distributed prior to Air Force review. The publication of this report, therefore, does not constitute approval by the Air Force of the findings or conclusions contained herein. It is published for the exchange and stimulation of ideas.

## ABSTRACT

The main activity on the Large Retractable Solar Cell Array (LRSCA) program during the second quarterly reporting period consisted of design and analysis of major subsystem components, test and development planning, design and fabrication of a solar cell array test bed, preparation of a preliminary reliability apportionment, release of a preliminary instrumentation subsystem design specification, negotiation of the extendible boom actuator unit subcontract with SPAR Aerospace Products of Canada, Ltd., and preparation of the Preliminary System Design Specification.

A major program redirection occurred during this reporting period — the use of GFE (8-mil thick, 2 x 2 cm) cells rather than the standard (12 to 14 mil thick, 2 x 2 cm) cells previously planned. The same directive authorized a study to determine momentum-storage wheel requirements to compensate for the disturbing torques resulting from orientation mechanism maneuvers.

## CONTENTS

	<u>Page</u>
I. INTRODUCTION AND SUMMARY	1
II. PROGRAM STATUS	
Phase I – Program Definition	3
Phase II – Design Study and Analysis	3
Phase III – Experimental Model Fabrication	5
Phase IV – Qualification and Flight Acceptance Tests	5
Phase V – Flight Test and Data Analysis	5
III. SYSTEMS ENGINEERING	
Design and Test Requirements Specification	7
LRSCA Mission Sequence	7
LRSCA Weight Summary	8
IV. SOLAR ARRAY SUBSYSTEM	
Subsystem Description and Status	13
Storage Drum Mechanisms	15
Flexible Solar Arrays	21
Plans for Next Quarter	27
V. ORIENTATION LINKAGE SUBSYSTEM	
Summary	29
Electronic Mechanization	29
Design Verification Test Plan	29
Torquer Evaluation	34
Momentum Cancellation	38
Orientation Subsystem Specification	39
Plans for Next Quarter	39
VI. POWER SUBSYSTEM	41
VII. INSTRUMENTATION SUBSYSTEM	
Purpose and General Requirements	43
Composite Air/Ground Telemetry Link	43
Progress During Second Quarter	43
Problem Areas	51
VIII. TEST	
Water Table	53
Status	53
Planned Activity for Third Quarter	53
IX. RELIABILITY	55

## ILLUSTRATIONS

1	Program Schedule	4
2	Solar Array Subsystem	14
3	Extendible Boom Actuator Unit	16
4	Details of Extendible Boom Actuator Unit	17
5	Boom Length Compensator Test Setup	18
6	Negator and Overall Development Test Rig	19
7	Bearing Friction Test Setup	20
8	Temperature Predictions	22
9	Control Electronics Unit Mechanization	31
10	Telemetry Subsystem Block Diagram	44
11	Reliability Apportionment of 1.5 kw Design	55

## TABLES

I.	LRSCA Command List	8
II	LRSCA System Weight Summary	10
III	Comparison of Brush/Sliprings and Flexible Flat Cables	24
IV	Solar Panel Output Characteristics (at Payload Interface)	26
V	Effect of Torquer Size on Electronics	36
VI	Effect of Torquer Size on Mechanism	37
VII	Solar Array Commutator Telemetry Measurements	46
VIII	Orientation Linkage Commutator Telemetry Measurements	48
IX	Power Conditioning Unit Telemetry Measurements	50

## SECTION I

### INTRODUCTION AND SUMMARY

This document reports the progress in the second quarter (28 September to 27 December 1968) on AFAPL Contract No. F33615-68-C-1676, Large Retractable Solar Cell Array, Project Number 682J.

The activity during the second quarterly reporting period consisted of 1) design and analysis of major subsystem components, 2) test and development planning, 3) design and fabrication of a solar cell array test bed, 4) preparation of a preliminary reliability apportionment, 5) release of a preliminary instrumentation subsystem design specification, 6) negotiation of the extendible boom actuator unit subcontract with SPAR Aerospace Products of Canada, Ltd., and 7) preparation of the Preliminary System Design Specification.

A major change order was received during this reporting period. Government-furnished (GFE) (8-mil thick) 2 x 2 cm cells were substituted for standard (12 to 14 mil thick) 2 x 2 cm solar cells. The same directive instructed Hughes to proceed with a study to determine momentum wheel requirements to compensate for the disturbing torques from orientation mechanism maneuvers.

The format of this report is designed to present the status of each major system element in a separate section.

## SECTION II

### PROGRAM STATUS

The Large Retractable Solar Cell Array (LRSCA) Program is divided into five phases, as described in the paragraphs that follow. The current program schedule and status are shown in Figure 1.

#### PHASE I - PROGRAM DEFINITION

During the second quarter, the first contractual LRSCA semiannual program presentation was made at the Hughes El Segundo facilities. The presentation was well received by key personnel from AFSC (Wright-Patterson), SAMSO, JPL, NASA/Lewis, and Aerospace.

While major milestones associated with this phase were not scheduled during this period, much of the background documentation has been completed in preliminary or draft form. Included in this category are preliminary releases of the life test requirements plan, design specification, engineering model test plan and procedures, and instrument subsystem design specification. The final interface specification and orbital experiment plan will be completed when the orbital vehicle integrator is chosen.

During the third quarter, the final qualification model design and test specification will be written, as scheduled.

#### PHASE II - DESIGN STUDY AND ANALYSIS

The Design Study and Analysis Phase includes most of the detailed analyses of the 1.5 kw LRSCA baseline design and the associated 5.0 kw design and 0.5 to 20.0 kw parametric studies. Component development tests and detail design, also scheduled for this phase, have been initiated. The most significant progress in this respect is the design and test activity associated with the solar array mechanisms, and materials and processes of the array cushion and substrate (see Section IV).

The analytic elements of the reliability program, also part of this phase, have been initiated with the release of an updated reliability apportionment to the control item level. The mathematical model and reliability prediction, failure modes and effects analysis, and maintainability prediction will be completed during the third quarter.

The component life tests will be started during this phase and will subject all critical components that have not been flight-qualified to the equivalent of 1 year (minimum) accelerated life testing.

80533-1(U)

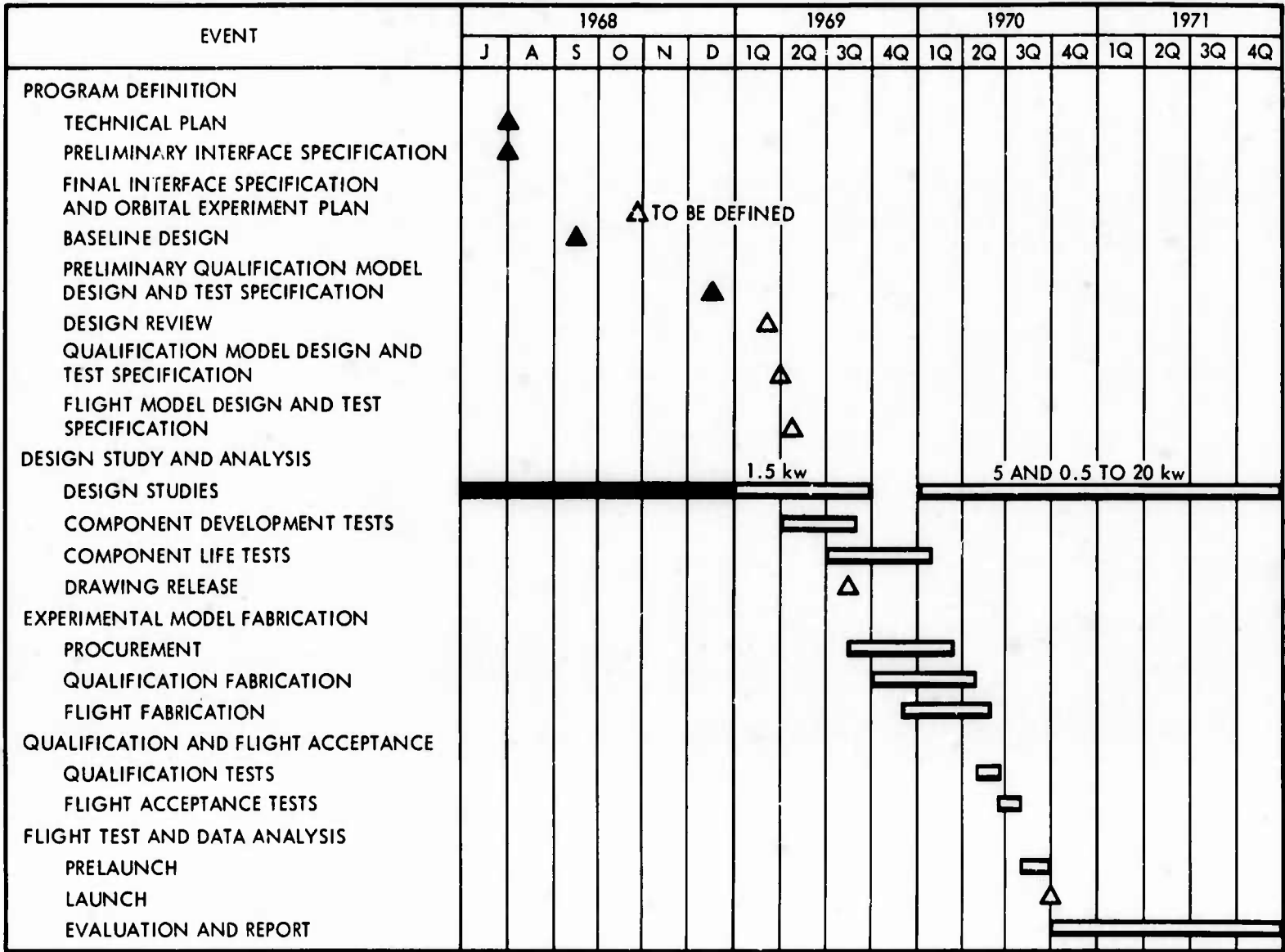

Figure 1. Program Schedule

### PHASE III - EXPERIMENTAL MODEL FABRICATION

This phase begins with the procurement of critical parts, such as the solar cells and the storable tube extendible members (STEM), and ends with the completion of the qualification and experimental models.

During this period, a subcontract was placed with SPAR Aerospace Products, Ltd., Canada, for the extendible boom actuator units. The battery procurement package was completed. Pursuant to the change from 12-mil thick solar cells to 8-mil thick GFE cells, the solar cell and coverslide procurement package was completed and an order placed for applying coverslides to 1400 cells for development testing.

### PHASE IV - QUALIFICATION AND FLIGHT ACCEPTANCE TESTS

Qualification and flight acceptance tests will be conducted according to the General System Test Plan, which includes formalized qualification tests, acceptance tests, and environmental tests.

The only activity within this phase has been the design and fabrication of a water table for the low-friction extension and retraction of the solar array. Although planned for a later start in support of system test, the design of this table was accelerated so that it could be used for development testing.

### PHASE V - FLIGHT TEST AND DATA ANALYSIS

The Flight Test and Data Analysis Phase will include prelaunch checkout and countdown procedures, as well as in-orbit operation and analysis.

### SECTION III

#### SYSTEMS ENGINEERING

#### DESIGN AND TEST REQUIREMENTS SPECIFICATION

Considerable progress has been made in the preparation of DS 30992-001, Performance, Design and Product Confirmation Requirements for HS-207 Large Retractable Solar Cell Array Experiment, Qualification Model. The specification is a combined environmental, design, and test requirements specification for the total LRSCA experiment and each of the subsystems and control items. Consequently, all of the information normally found in a group of documents will be contained within a single specification.

During this reporting period, a coherent and flexible specification format was prepared to permit the orderly inclusion of all necessary detailed information. Some slight modifications to the format may be required as the specification preparation progresses.

The LRSCA experiment description and requirements were prepared on the basis of the information documented in the Statement of Work of the contract and modified by subsequent negotiations. In the preparation of the specific LRSCA requirements, it is assumed that the launch vehicle is to be a Titan III/Agena combination and that the orbit will be essentially circular and polar between 400 and 500 miles altitude.

On the bases defined above, major portions of the specification relating to descriptions and requirements of the total LRSCA experiment, as well as the four subsystems and their control items, have been prepared. Detailed examination and definition of the subsystem requirements resulted in modifications to both the telemetry and command lists. A current telemetry list appears in Section VII of this report. The modified command list is shown in Table I.

A preliminary draft of the specification was released 18 December 1968. This draft will be used as the vehicle for gathering the various subsystem requirements necessary to complete the specification. The section of the specification relating to test requirements, as well as the remainder of the document, is planned for completion (preliminary draft) on approximately 15 January 1968. Final release of the specification is scheduled for the end of the next quarter.

#### LRSCA MISSION SEQUENCE

A preliminary draft of a LRSCA mission sequence was prepared, which included command logic and mechanization for the power conditioning and storage subsystem and the orientation linkage subsystem. This draft identified

some of the command and telemetry requirements. The sequence includes details relating to operations under the following conditions:

- 1) On-pad
  - a) Initial checkout configuration
  - b) Power ON checks
  - c) Prelaunch operations
- 2) Flight
  - a) Launch/powered flight
  - b) Initial deployment
  - c) Orientation linkage lockon
  - d) Voltage-current curve assessment
  - e) Eclipse operation

Since the preliminary release, a number of modifications have been implemented as a result of further definition of subsystem requirements. The LRSCA mission sequence will be included in the LRSCA Space Experiment Plan, tentatively scheduled for release in April 1969.

#### LRSCA WEIGHT SUMMARY

A current system weight summary is shown in Table II. It should be noted that a weight saving of 7.37 pounds has been accomplished in the orientation linkage and solar array subsystems since the original system was proposed. As discussed in Section V, further weight reductions will result from the selection of Inland T-5134 motors in the orientation mechanism. These weight changes will be reported in the next monthly report.

TABLE I. LRSCA COMMAND LIST

<u>Command</u>	<u>Command Function</u>
1	Manual torque support X axis, OFF/Positive
2	Manual torque support X axis, OFF/Negative
3	Manual torque drum W axis, OFF/Positive
4	Manual torque drum W axis, OFF/Negative
5	Control electronics unit, OFF/ON

TABLE I. LRSCA COMMAND LIST (Continued)

<u>Command</u>	<u>Command Function</u>
6	Limit override, OFF/ON
7	Solar array power switch, Disable
8	Solar array power switch, Enable
9	Overvoltage/undervoltage override OFF
10	Overvoltage/undervoltage override ON
11	Solar array extend
12	Solar array retract
13	Solar array motor, Disable
14	Solar array motor, Enable
15	Battery charge, Disable
16	Battery charge, Enable
17	Load bank 1, ON
18	Load bank 2, ON
19	Load bank 3, ON
20	Load bank 4, ON
21	Load bank 1, OFF
22	Load bank 2, OFF
23	Load bank 3, OFF
24	Load bank 4, OFF
25	Sun lockon override Enable
26	Sun lockon override Disable
27	Release and extend logic override Enable
28	Release and extend logic override Disable

TABLE I. LRSCA COMMAND LIST (Concluded)

<u>Command</u>	<u>Command Function</u>
29	Retract logic override Enable
30	Retract logic override Disable
31	Manual sun lockon OFF/ON
32	Manual sun present OFF/ON

TABLE II. LRSCA SYSTEM WEIGHT SUMMARY

<u>Subsystem</u>	<u>Weight, pounds</u>
<u>Orientation Linkage</u>	
Structure	16.2
Controls and avionics	19.7
Motors and tachometers	11.6
Sun sensors	1.6
Electronics	6.5
Power and signal transfer	7.6
Sliprings /brushes	5.9
Wire and connectors	1.7
Subsystem total	43.5
<u>Solar Array</u>	
Solar array panel	37.96
Cells with covers	32.10
Cell Z-strips	1.60
Fiber glass and adhesive	1.34
Kapton substrate	1.41
Power bus	1.51

TABLE II. LRSCA SYSTEM WEIGHT SUMMARY (Concluded)

<u>Subsystem</u>	<u>Weight, pounds</u>
Array cushion, reel, and drive	2.92
Drum mechanisms	32.24
Drum, spar, and thermal covers	9.72
Actuators	16.52
Power harness and hardware	2.35
Sliprings/brushes	1.00
Spreader bar	2.05
Bi-STEM equalizer assembly	0.60
Subsystem total	73.12
<u>Power Conditioning and Storage</u>	
Batteries	37.8
Control electronics	17.5
Subsystem total	55.3
<u>Instrumentation</u>	<u>7.45</u>
<u>LRSCA System (Total)</u>	<u>182.37</u>

## SECTION IV

### SOLAR ARRAY SUBSYSTEM

#### SUBSYSTEM DESCRIPTION AND STATUS

The solar array subsystem consists of the storage drum mechanisms and two flexible solar cell arrays (see Figure 2). The flexible arrays are wound on the storage drum during launch and deployed after the vehicle is in orbit. Deployment is accomplished by means of boom assemblies mounted on the storage drum structure.

The following significant items and tasks have been accomplished during the second quarter of the program:

- 1) Completion of design layouts incorporating baseline configuration
- 2) Placement of subcontract and start of design on extendible boom actuator units
- 3) Completion of preliminary subsystem design specifications
- 4) Completion of test equipment design and fabrication for boom length compensators, drum bearings, and negator drive development tests
- 5) Start of development tests of boom length compensator mechanism
- 6) Completion of thermal analysis of panels for 400 n.mi. and synchronous altitude orbits
- 7) Completion of thermal analysis of drum mechanisms for synchronous altitude conditions
- 8) Completion of preliminary analysis of drum mechanism dynamic loads
- 9) Reevaluation of drum mechanism power transfer configuration
- 10) Completion of analysis of panel dimensions, voltage levels, and power output for 8 mil solar cells
- 11) Start of several solar panel materials and processes evaluation tests
- 12) Fabrication of segment of solar array for panel tension tests

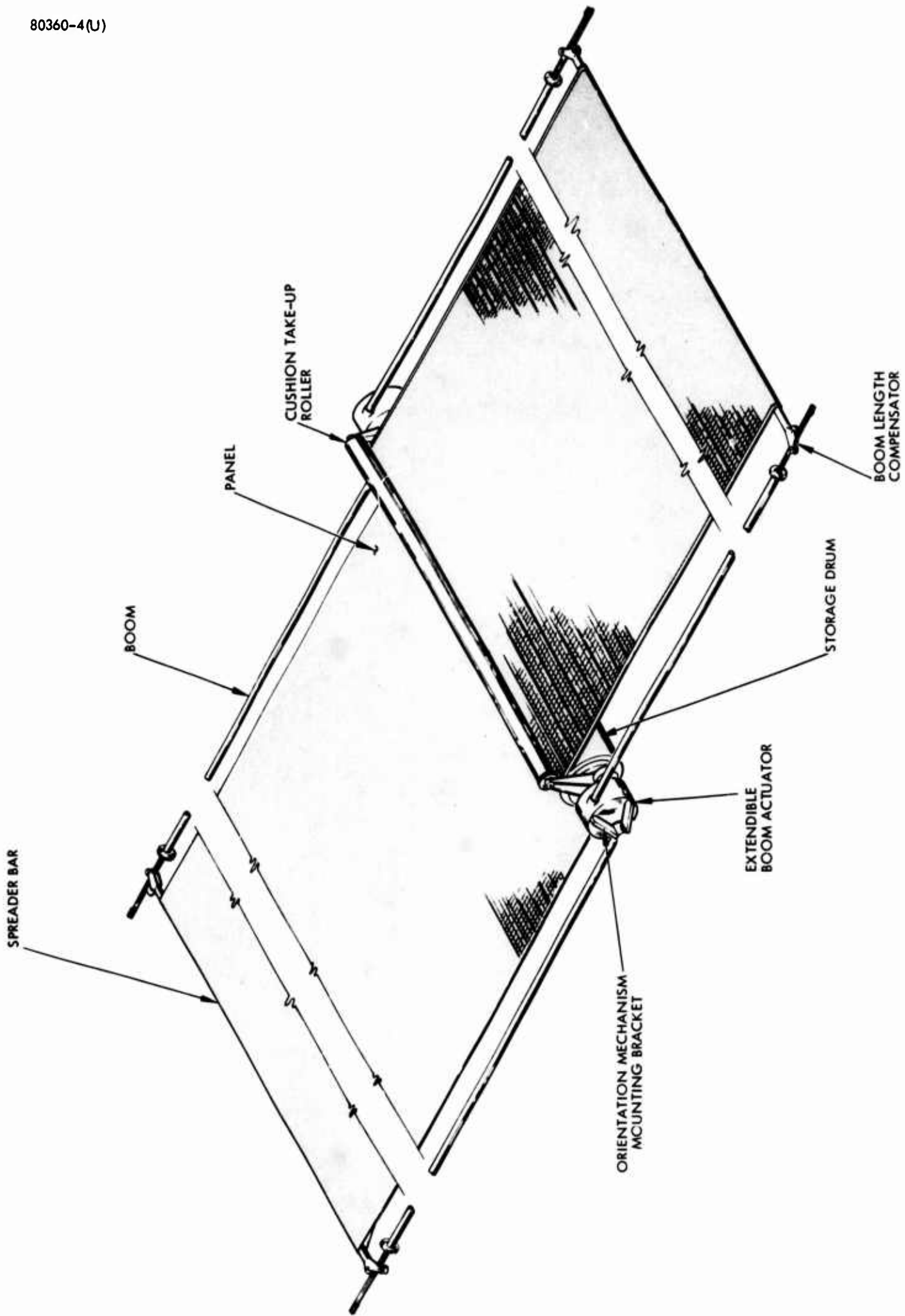

Figure 2. Solar Array Subsystem

## STORAGE DRUM MECHANISMS

### Boom Actuators

The subcontract for the extendible boom actuator units has been placed with SPAR Aerospace in Toronto, Canada (Figures 3 and 4). Since the placement of the contract, the following tasks have been accomplished:

- 1) Completion of design layout and outline and mounting drawing
- 2) Fabrication and beginning of tests on breadboard model of one boom cassette assembly
- 3) Preliminary formulation of development test plan
- 4) Preparation of documentation for ac motor drive subcontract
- 5) Coordination meeting of Hughes and SPAR personnel to review design layout, test plans, etc.

One of the critical areas discussed at the recently concluded coordination meeting was lubrication of the gears and bearings. The large dynamic loads, along with the requirement for many cycles of operation, impose severe requirements on the planned all-dry lubrication system. Since dry lubrication is considered an extremely important feature, it was agreed that every effort should be made to satisfy the requirement. The current plan, therefore, is to employ ball bearings with Duroid 5813 retainers and MoS<sub>2</sub> burnished races and balls, and gears with MoS<sub>2</sub> dry film lubrication.

### Boom Length Compensators

The function of the boom length compensators is to equalize the tension on the flexible panels for variable extension rates of the individual booms. Detail parts for this assembly have been designed, fabricated, and installed in a development test setup (Figure 5). The test program will determine the panel tension variations due to unequal boom deployment, the effect of launch panel tension on spreader bar deflections and substrate adhesive bonding, the suitability of strain gage instrumentation on spreader bar or boom length compensator tape, and wear characteristics of the mechanism components. Room temperature runs have been completed successfully (0.316 variation between booms). Tests at mission temperature extremes are in process.

### Cushion Take-up and Drum Negator Drives

The negator drive on the storage drum provides tension on the panel during the deployment and retraction phases of operation. The purpose of the cushion take-up is to roll up and store the cushion when the panels are deployed and to deploy the cushion between the two panels during the retraction cycle. A test rig for evaluating these drives has been designed and

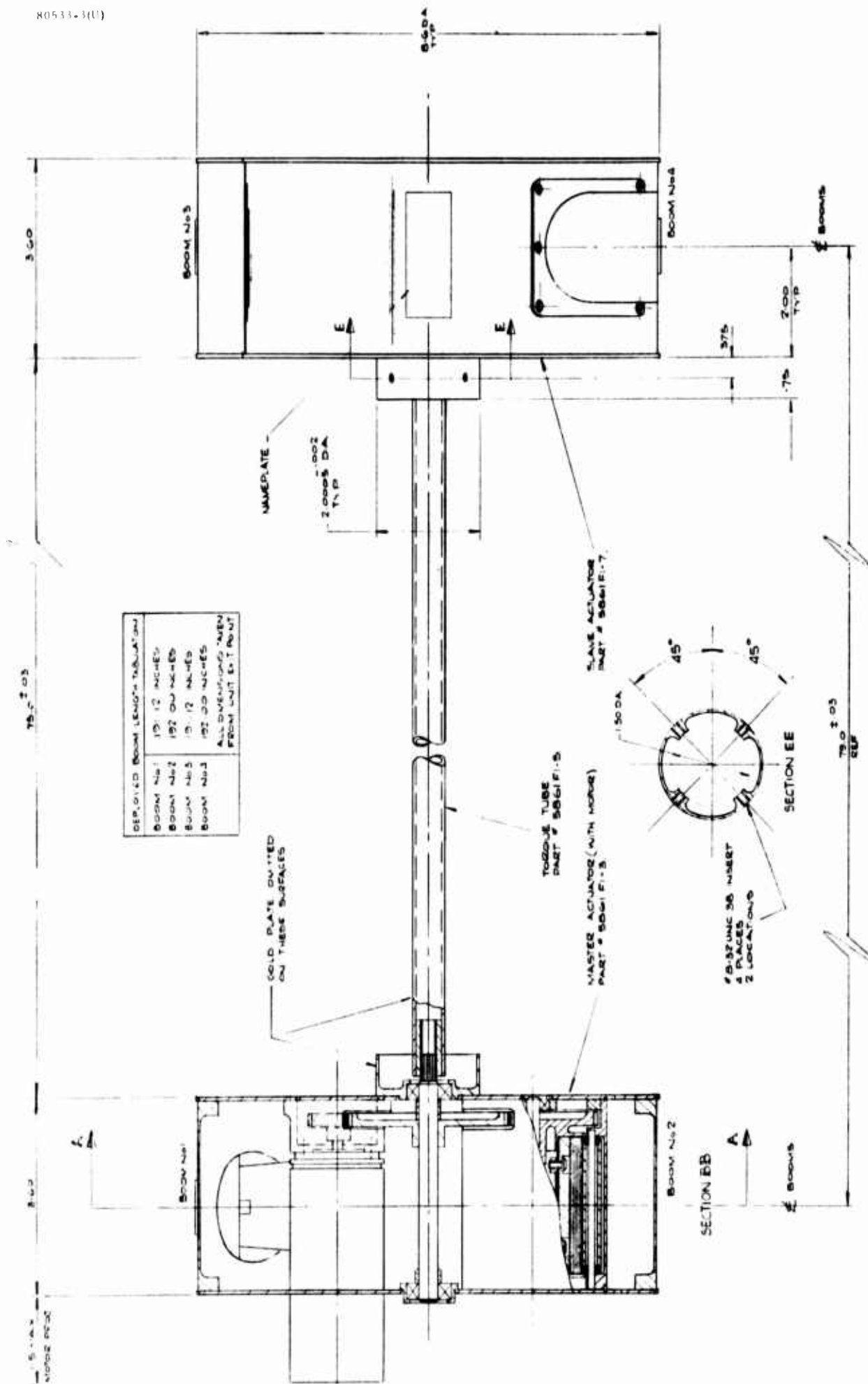

Figure 3. Extensible Boom Actuator Unit

fabricated (Figure 6). The purpose of the tests is to determine force characteristics of the drives as a function of deployed length. Of particular interest will be the hysteresis of these drives at the expected temperature extremes. Tests will begin in February, by which time purchased parts are expected to become available.

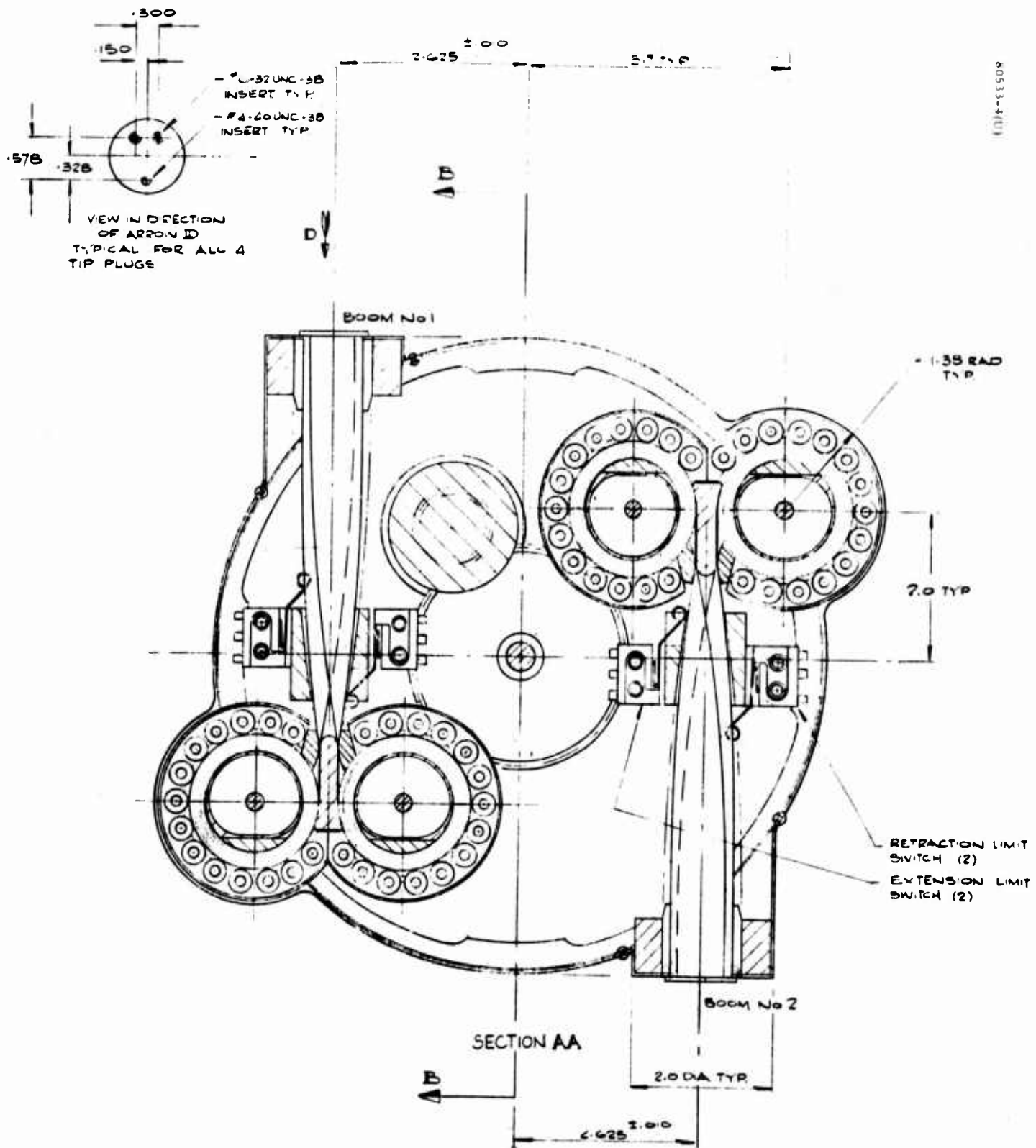

Figure 4. Details of Extensible Boom Actuator Unit

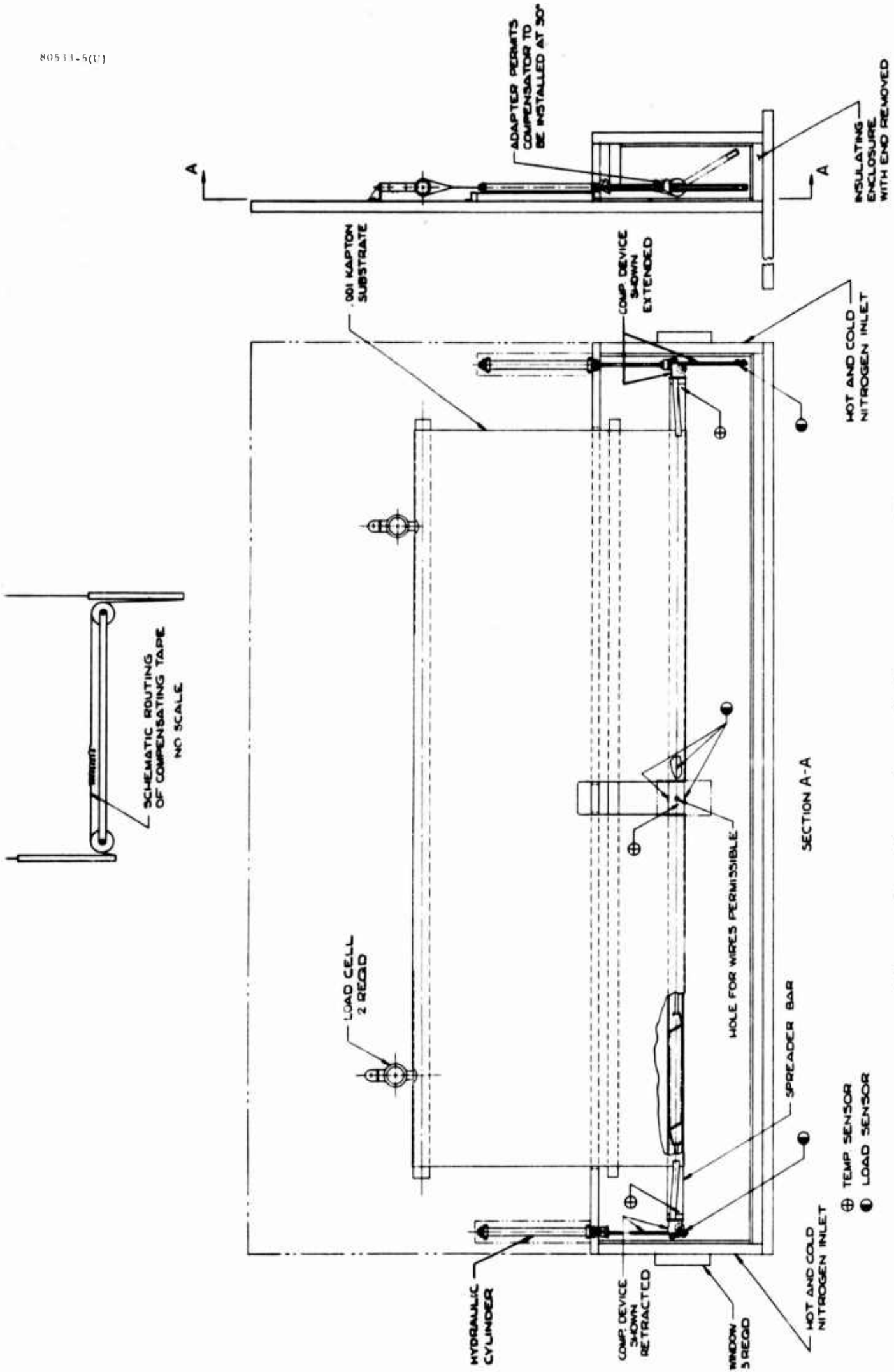

Figure 5. Boom Length Compensator Test Setup

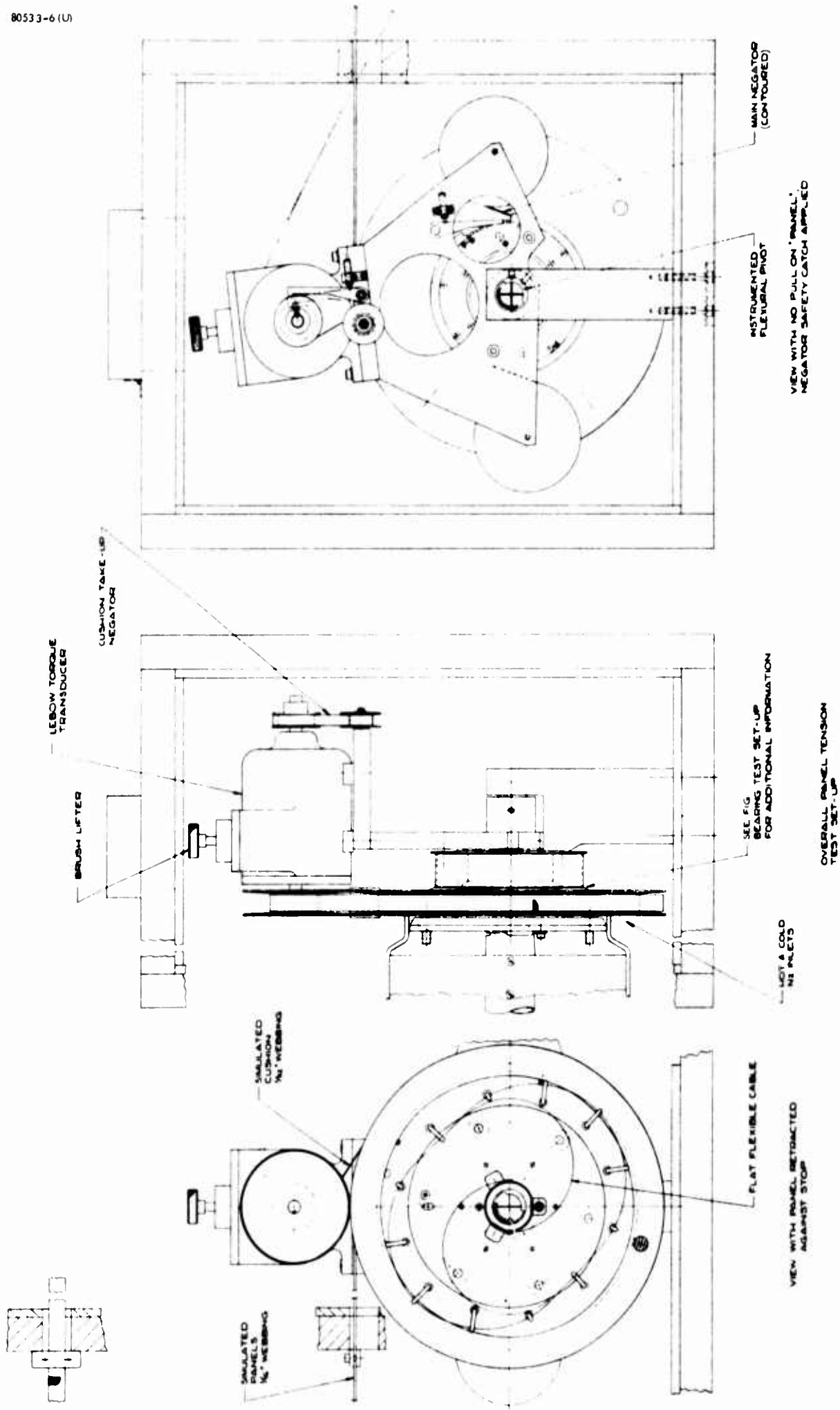

Figure 6. Negator and Overall Development Test Rig

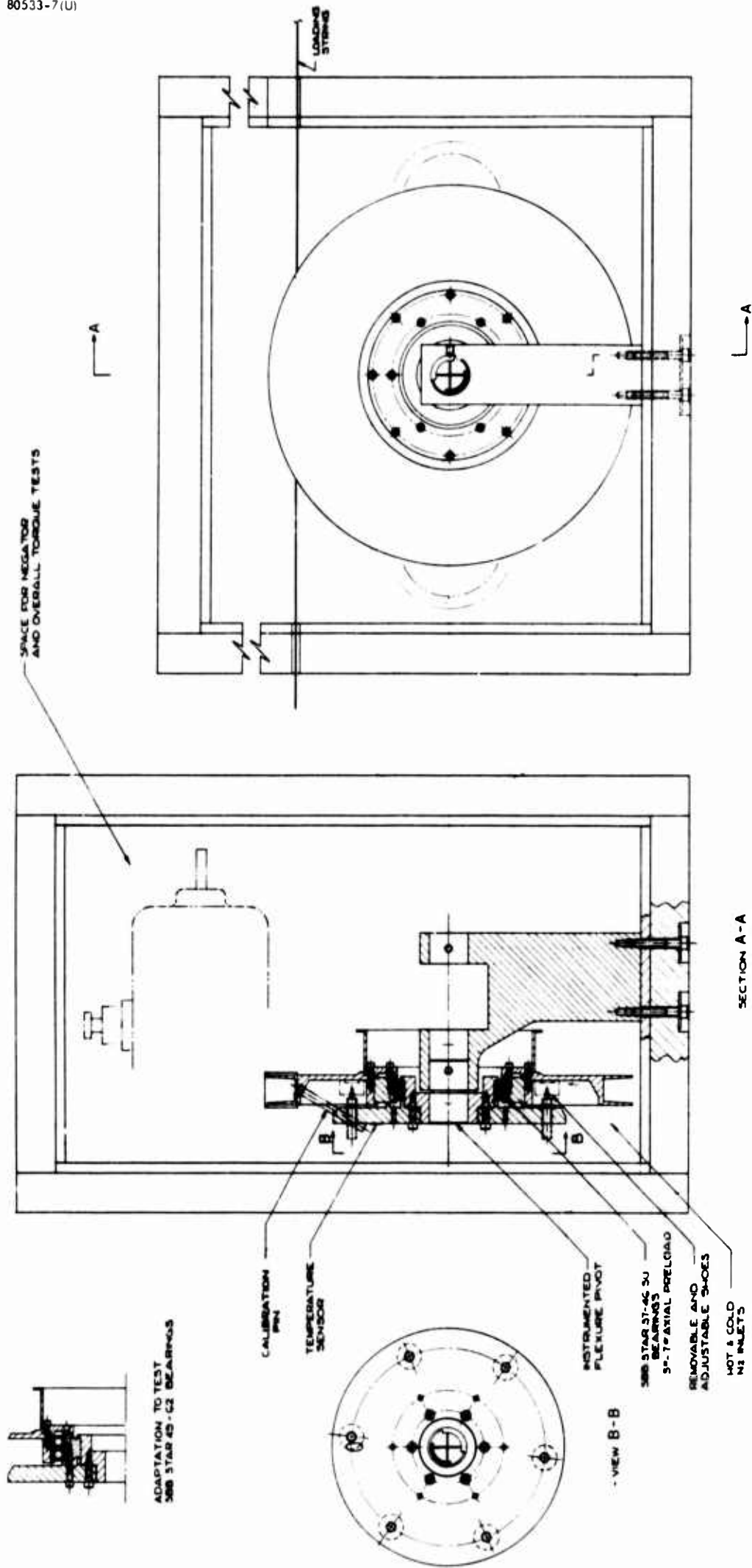

Figure 7. Bearing Friction Test Setup

## Drum Bearings

The drum bearings employ a glass-reinforced teflon and MoS<sub>2</sub> retainer (Duroid 5813) with burnished MoS<sub>2</sub> on races and balls. Test parts with one piece retainers are on order and will be used in the same test rig employed for the negator drives (Figure 7). They will be tested individually and with the other components of the drum mechanisms at the high and low temperature extremes.

## Drum Power Transfer Configuration (Flexible Flat Cable Versus Sliprings)

Since the 1500-watt flexible integrated solar cell array (FISCA) drum rotates less than eight turns on deployment and since there are many data conductors (11 plus spares) required in addition to the eight power conductors, a new look is being taken at flat flexible cables in the drum mechanism. On the basis of equal power losses, sliprings are expected to be somewhat lighter for the power transfer alone but heavier for the data conductors. Because the expected slipring power loss of less than 6 watts out of 1500 is small, however, it is considered reasonable to accept as much as three times this loss in a flexible flat cable. The higher power losses are dissipated in a flat cable over a relatively large area and not localized as in the brush/slipring arrangement. By accepting this larger power loss, a total weight saving of about 1.5 pounds is realized - 0.5 pound in power conductors and 1 pound in data conductors (see Table III). Other advantages of the flexible flat cable are elimination of slipring noise, lower cost, and decreased complexity of drum design. A sample cable is currently being fabricated to verify feasibility.

## Storage Drum Thermal Analysis

The curves in Figure 8 present temperature profiles for the storage drum under synchronous equatorial orbit conditions. The thermal properties assumed for different areas of the drum are presented along with a pictorial description showing each temperature location. Further analysis is in progress, and similar curves for the 400 n. mi. circular polar orbit case will be generated.

## FLEXIBLE SOLAR ARRAYS

The flexible solar arrays consist of the following components:

- 1) Bonded Kapton and fiberglass substrate base for supporting solar cells
- 2) Etched copper foil circuit on Kapton base for collecting power from solar cell groups and transmission to connections on drum
- 3) Solar cells in groups of 3 in parallel and 81 in series, interconnected by expanded copper foil strips soldered to cell contacts

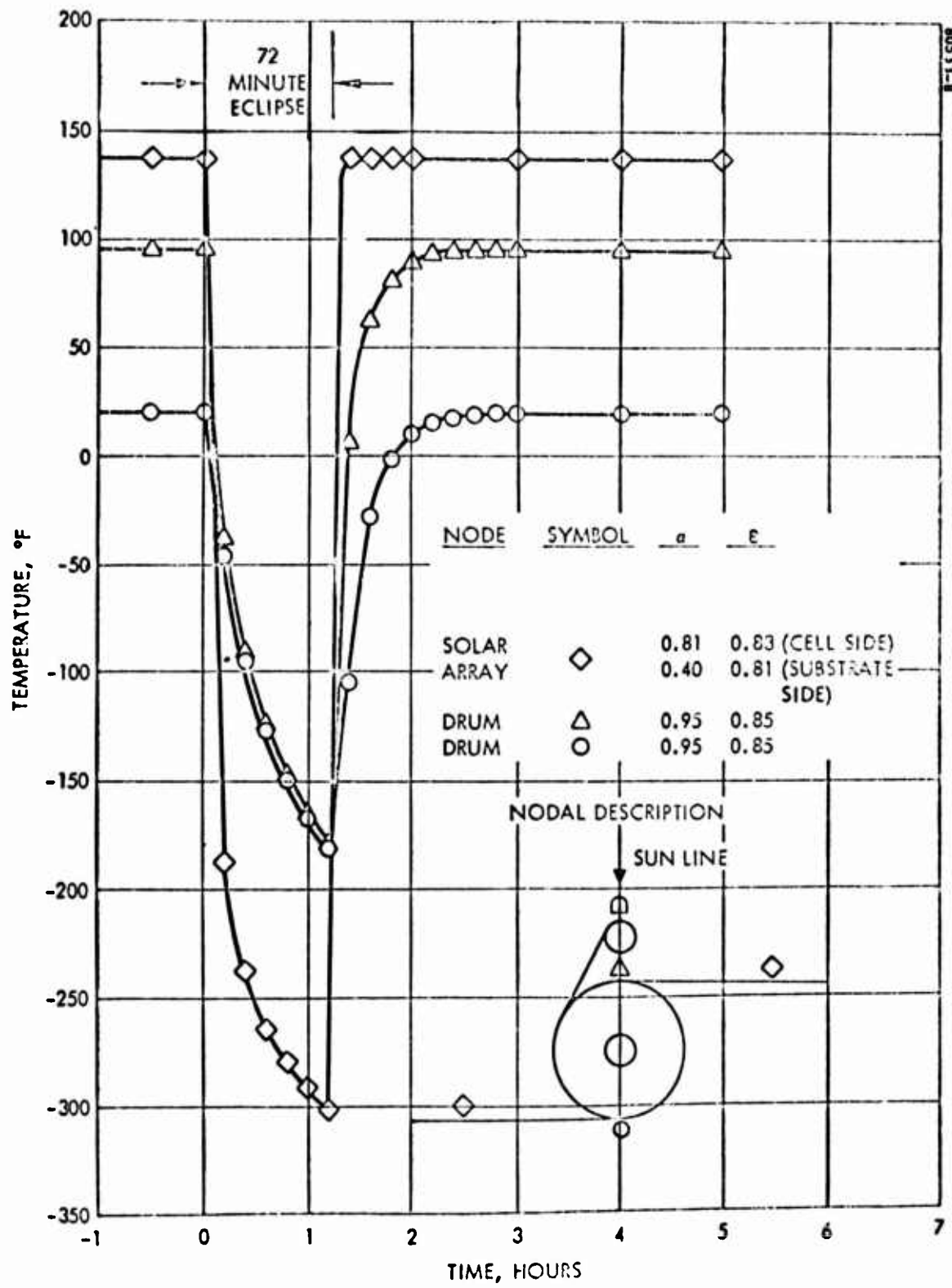

a) Solar Array and Storage Drum

Figure 8. Temperature Predictions

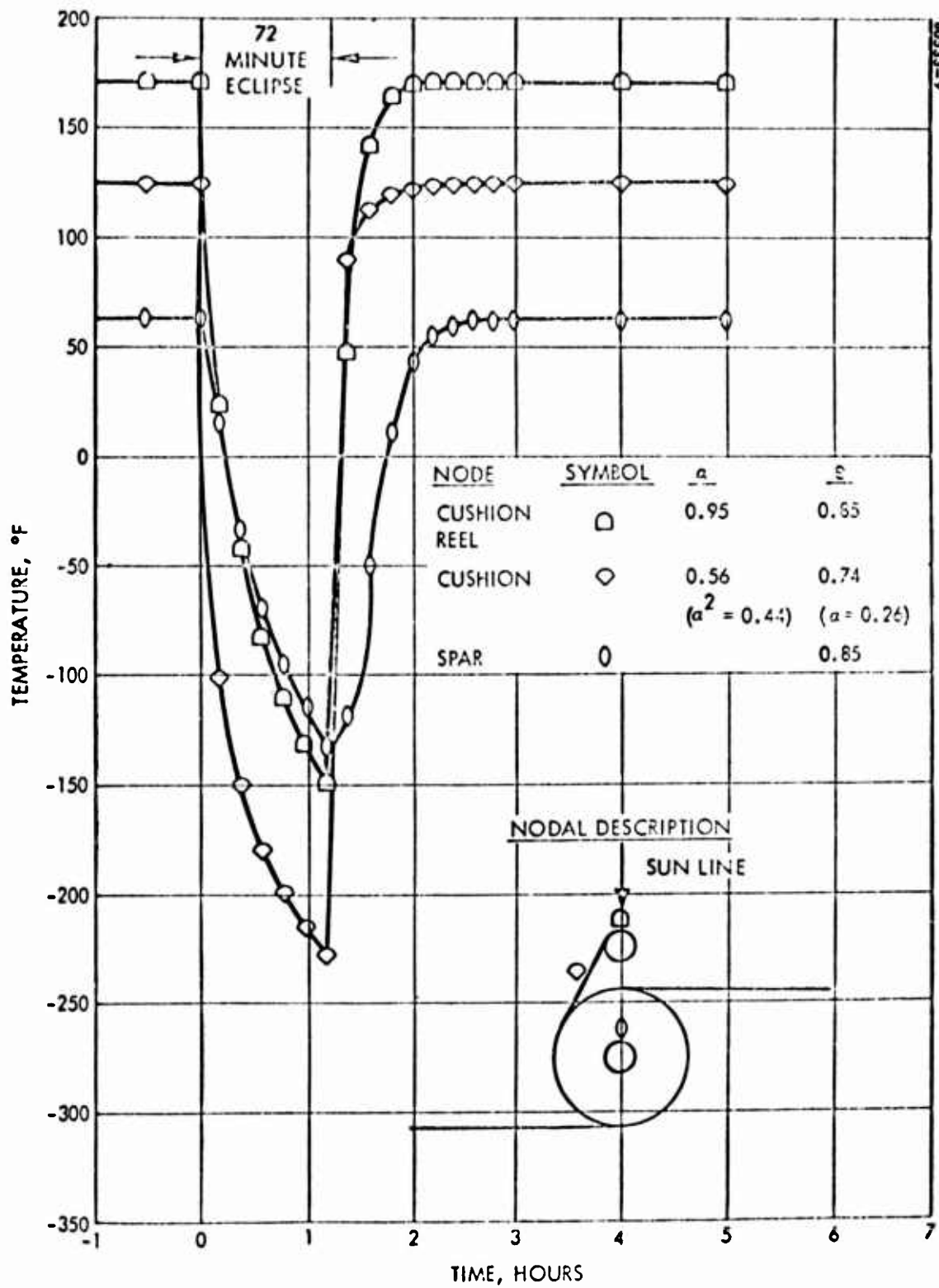

b) Cushion, Cushion Reel, and Spar

Figure 8 (continued). Temperature Predictions

TABLE III. COMPARISON OF BRUSH/SLIPRINGS AND FLEXIBLE FLAT CABLES

Power Per FISCA, kw	Type	Resistance Ratio	Voltage Drop, volts	Power Loss, watts	Weight of Power Conductors, pounds	Weight of Data Conductors, (14 Circuits), pounds	Total Weight, pounds
1.5	Brush/slipring	R**	0.1175	5.90	0.976	1.064	2.040
	FFC*	3/4R	0.0882	4.42	1.76	0.12	1.88
	FFC	1R	0.1175	5.90	1.32	0.09	1.41
	FFC	1.5R	0.1764	8.84	0.88	0.06	0.94
	FFC	2R	0.2350	11.80	0.66	0.05	0.71
	FFC	3R	0.3528	17.68	0.44	0.03	0.47
2.5 (27-foot boom)	Brush/slipring	R	0.0978	8.15	1.264	1.064	2.328
	FFC	3/4R	0.0733	6.11	4.62	0.38	5.00
	FFC	1R	0.0978	8.15	3.46	0.28	3.74
	FFC	1.5R	0.1466	12.22	2.84	0.20	3.04
	FFC	2R	0.1956	16.30	1.73	0.14	1.87
	FFC	3R	0.2932	24.44	1.42	0.10	1.52
2.5 (16-foot boom)	Brush/slipring	R	0.0978	8.15	1.264	1.064	2.328
	FFC	3/4R	0.0733	6.11	3.52	0.24	3.76
	FFC	1R	0.0978	8.15	2.64	0.18	2.82
	FFC	1.5R	0.1466	12.22	1.76	0.12	1.88
	FFC	2R	0.1956	16.30	1.32	0.09	1.41
	FFC	3R	0.2932	24.44	0.88	0.06	0.94

\*FFC = Flexible flat cable.

\*\*R = Resistance of currently planned brush/slipring configuration.

- 4) Glass covers with autoreflective and ultraviolet filter coatings for environmental and radiation protection of solar cells
- 5) Embossed Kapton cushion for protecting cells in rolled-up configuration

A significant change in the solar panel design is the change of solar cells. The originally proposed 12-mil thick 10 ohm-cm solar cells have been replaced with 8-mil thick 2 ohm-cm solar cells.

#### Structural Dynamic Analysis of Flexible Solar Array in Stowed Position

Dynamic analysis and load calculations were performed for the flexible solar cell array subsystem when stowed in an upright position on the launch vehicle. The quasi-static accelerations at the array mounting interface were set at  $\pm 12$  and  $\pm 3.8$  g in longitudinal and both lateral directions of the launch vehicle, respectively. These levels were derived for the Titan IIIC booster, considering steady-state accelerations, local flexible body response, and a flight ultimate load factor.

The loads imposed by acoustically induced vibrations in the transonic flight regime were determined by analysis. The random excitation levels used in the analysis are those specified for the Titan IIIC component qualification.

#### Analysis of 8-Mil Solar Cells

A detailed analysis has been made of the panel size, power output, and voltage levels for the 8-mil solar cells. By considering the thermal characteristics of the cells and the degradation due to coverslides and fabrication, the voltage and power levels were calculated for various parallel and series cell arrangements. The solar array size based on these calculations is 81 cells wide (connected in series) by 222 cells long (connected in parallel). With this configuration and an estimated 2.5 volt drop between panel and payload interface, the solar panel output characteristics are shown in Table IV.

#### Solar Panel Test and Development Activity Panel Tension Tests

The test specimen for analyzing the panel tension required to wrap the array on an 8-inch diameter drum has been completed. This specimen is 5 inches wide, 25 inches long, and includes cell interconnects and bus-bars to be representative of a full-size array in regard to flexure characteristics. Since cell thicknesses have negligible effect on panel tension/rollup characteristics, rejected 12-mil cells with 12-mil covers were used rather than the flight-quality 8-mil cells with 6-mil covers.

The test setup has been completed and tests are to start in the middle of January. These tests will be run at room temperature as a result of a decision that solar array extension and retraction will occur only under the elevated temperature condition of solar exposure.

TABLE IV. SOLAR PANEL OUTPUT CHARACTERISTICS  
(AT PAYLOAD INTERFACE)

	Voltage, volts	Current, amperes	Power, watts
Contract condition, 130°F (54.4°C) 400 n. mi. altitude	31.1	24.1	750
Minimum temperature ~ 144°F(62°C)	29.8	24.3	724
Maximum temperature ~ 200°F(93°C)	24.5	24.9	610
Average	27.2	24.6	667

#### Kapton Cushion Development

A production method has been developed for forming the embossed Kapton cushion. Small size cushion specimens are currently being evaluated. This evaluation includes measurement of spring rate and recovery characteristics as a function of time and temperature. Tests have been completed for the room temperature phase and are continuing for elevated temperatures of 120°, 150°, and 175°F. These tests are considered necessary before beginning fabrication of special tools for forming a full width cushion.

#### Materials and Processes Development

Several fabrication processes have been developed and evaluated prior to the fabrication of the array for the panel tension test. These include the following:

- 1) Etching of 0.0007-inch copper foil bus strips on 0.5 and 1-mil Kapton base
- 2) Bonding of Kapton lap joints with liquid epoxy adhesive
- 3) Bonding of bus strips to Kapton
- 4) Bonding of fiberglass to Kapton in areas without cells
- 5) Bonding of small solar cell groups to substrate, including areas over bus strips
- 6) Evaluation of thermal stabilization, surface preparation, and humidity effect on bonding operations

Additional fabrication processes requiring development include the following:

- 1) Stripping of Kapton film from bus strip material in local areas for soldered electrical connections and splices
- 2) Development of thermoforming film adhesive bonding techniques, which are expected to be appropriate for some of the required bonding

#### PLANS FOR NEXT QUARTER

Activities next quarter will include the following:

- Continuation of materials and processes evaluation
- Start of detailed drawing task
- Panel tension test program
- Completion of thermal analysis
- Boom length compensator development tests
- Start of stress analysis
- Bearing and negator evaluation tests

## SECTION V

### ORIENTATION LINKAGE SUBSYSTEM

#### SUMMARY

Significant effort during this reporting period was devoted to detailing the design of the control electronics and preparation of a development test plan for the linkage mechanism. Additionally, the subject of dc torquer capability under adverse conditions was examined, and the effect of an increased torquer diameter on the mechanism layout was evaluated. Subsystem material for incorporation in the system design specification was generated. Plans were developed for study and definition of a momentum-cancellation subsystem to counteract the primary torques required for array steering.

#### ELECTRONIC MECHANIZATION

Mechanization of the control electronics unit (CEU) has been defined in detail (Figure 9). This diagram illustrates the inputs, logic operations, and operational and power amplification employed to drive the control system torquers.

In addition to accepting normal signals from the sun sensors, capability has been added to accept overriding ground commands indicating synthetic "sun-present" and "tracking sensor lockon" conditions. These commands were added to allow the system to be placed in the tracking mode in the event of failure of either of these signals to be generated normally. Other commands provide for turning the unit on and off, torquing either axis in either direction, and removing a normal 1 deg/sec limit on the steering rate command to cope with the possibility of a vehicle stabilization failure resulting in steady rates exceeding 1 deg/sec.

The sun acquisition sequence was described in the previous report. The circuitry provides for shaft rate feedback (for rate limiting) in the acquisition mode and in the tracking mode when rates reach a value of 1 deg/sec. During normal tracking, the rate signal is grounded and tracking-loop stabilization is obtained by optical error signal shaping. This is done to avoid vehicle stabilization perturbation rates from affecting array pointing. It also relieves the system from dependence on the rate sensors during tracking. The power amplifiers are operated in a high frequency switching mode in the interest of more efficient operation under continuous low-torque demand. Motor inductance smooths the power pulse trains to provide effective levels of motor current proportional to command.

#### DESIGN VERIFICATION TEST PLAN

Design verification tests of the orientation linkage are planned to ensure that the design will meet subsystem performance specifications and tolerate conditions to be encountered during system qualification.

The following types of measurements, as pertinent, will be made on the following elements of the orientation linkage:

- 1) Motor
  - a) Torque versus electrical input
  - b) Temperature rise
- 2) Sliprings
  - a) Friction torque
  - b) Electrical losses (power rings only) at selected brush current densities
  - c) Electrical noise
- 3) Bearings
  - a) Static and dynamic friction torques
- 4) Central assembly
  - a) Total friction torque versus temperature
  - b) Temperature at selected points
  - c) Angular rate versus command; threshold behavior with and without load inertia

Measurements will be made during the following test series:

- 1) Component and Unit Tests
  - a) Friction torque
  - b) Torque motor calibration
  - c) Unit performance
- 2) Ambient Functional Tests
- 3) Vibration Test
- 4) Ambient Functional Tests (selected sections)
- 5) Shock Test
- 6) Ambient Functional Test

### SWITCH FUNCTIONS AND LOGIC

WITH SUN PRESENT OR SUN PRESENT BACK-UP COMMAND				
NO.	AXIS	FUNCTION	LOGIC CONDITION TO OPEN	LOGIC CONDITION TO CLOSE
1	DRUM	POS RATE BIAS	$B_1 B_3 (P+R) \bar{T}$ DRUM AXIS ENABLE AND POS ANGLE ACQ DRUM AXIS	$\bar{B}_1 + \bar{B}_3 + \bar{P} \bar{R} + T$ NEG ANGLE ACQ DRUM AXIS OR SUPPORT AXIS ENABLE OR TRACKING MODE
2	DRUM	NEGRATE BIAS	$B_2 B_3 (P+R) \bar{T}$ DRUM AXIS ENABLE AND NEG ANGLE ACQ DRUM AXIS	$\bar{B}_2 + \bar{B}_3 + \bar{P} \bar{R} + T$ POS ANGLE ACQ DRUM AXIS OR SUPPORT AXIS ENABLE OR TRACKING MODE
3	DRUM	STEERING LOOP SHORT	$T$ TRACKING MODE	$\bar{T}$ ACQUISITION MODE
4	DRUM	STEERING LIMIT OVERRIDE	GROUND COMMAND TRACKING MODE	NORMALLY CLOSED TRACKING MODE
5	DRUM	RATE LOOP SHORT	$(P+R) \bar{T}$ OR RATE $> 1^\circ/\text{SEC}$ ACQUISITION MODE OR TRACKING MODE	$\bar{P} \bar{R} + T$ OR RATE $< 1^\circ/\text{SEC}$ TRACKING MODE
6	SUPPORT	POS RATE BIAS	$B_4 (P+R) \bar{T}$ SUPPORT AXIS ENABLE	$B_4 + \bar{P} \bar{R} + T$ DRUM AXIS ENABLE OR TRACKING MODE
7	SUPPORT	STEERING LIMIT SHORT	$T$ TRACKING MODE	$\bar{T}$ ACQUISITION MODE
8	SUPPORT	STEERING LIMIT OVERRIDE	GROUND COMMAND TRACKING MODE	NORMALLY CLOSED TRACKING MODE
9	SUPPORT	RATE LOOP SHORT	$(P+R) \bar{T}$ OR RATE $> 1^\circ/\text{SEC}$ ACQUISITION MODE OR TRACKING MODE	$\bar{P} \bar{R} + T$ OR RATE $< 1^\circ/\text{SEC}$ TRACKING MODE

#### LOGIC DEFINI

P — SUN PRESENT SENSOR ILLUMINATED  
 D<sub>1</sub> — POSITIVE ANGLE ACQUISITION SENSOR  
 D<sub>2</sub> — NEGATIVE ANGLE ACQUISITION SENSOR  
 L — LOCK-ON CELL ILLUMINATED  
 B<sub>1</sub> — POSITIVE ANGLE ACQUISITION SENSOR ENABLE  
 B<sub>2</sub> — NEGATIVE ANGLE ACQUISITION SENSOR ENABLE  
 B<sub>3</sub> — DRUM AXIS ENABLE  
 B<sub>4</sub> — SUPPORT AXIS ENABLE  
 T — TRACKING MODE  
 R — SUN PRESENT BACK-UP COMMAND  
 L<sub>c</sub> — LOCK-ON CELL BACK-UP COMMAND

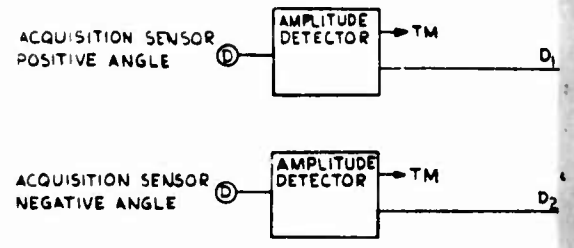

### TELEMETRY

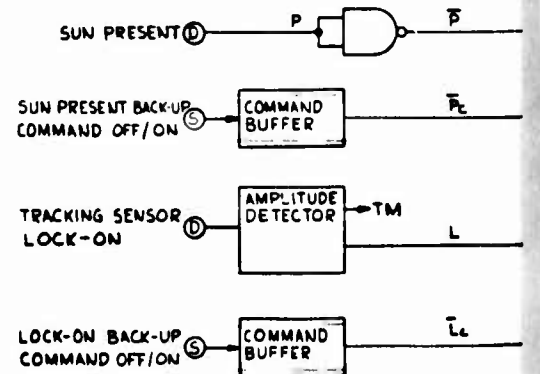
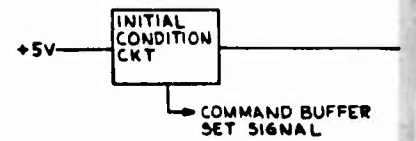
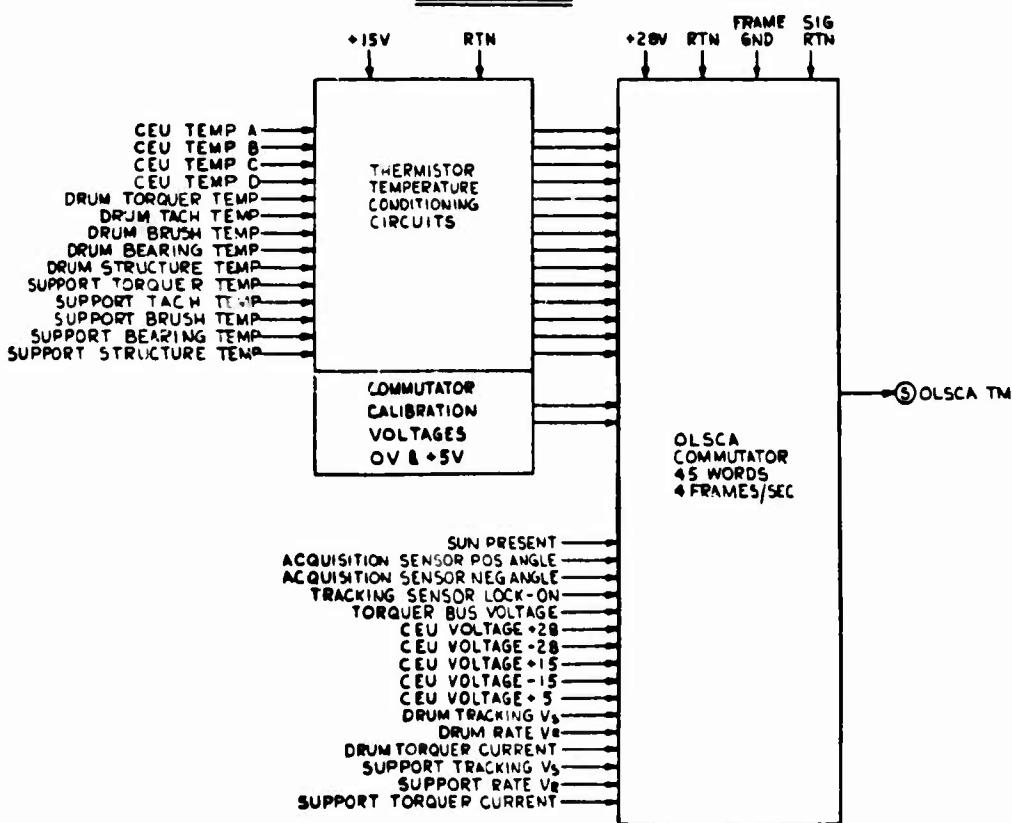

A

LOGIC DEFINITIONS

RESET SENSOR ILLUMINATED  
 VE ANGLE ACQUISITION SENSOR ILLUMINATED  
 VE ANGLE ACQUISITION SENSOR ILLUMINATED  
 ON CELL ILLUMINATED  
 VE ANGLE ACQUISITION  
 VE ANGLE ACQUISITION  
 VE ANGLE ACQUISITION  
 AXIS ENABLE  
 RT AXIS ENABLE  
 NG MODE  
 RESET BACK-UP COMMAND OFF/ON  
 ON CELL BACK-UP COMMAND OFF/ON

DRUM AXIS CHANNEL

STEERING AMPLIFIER

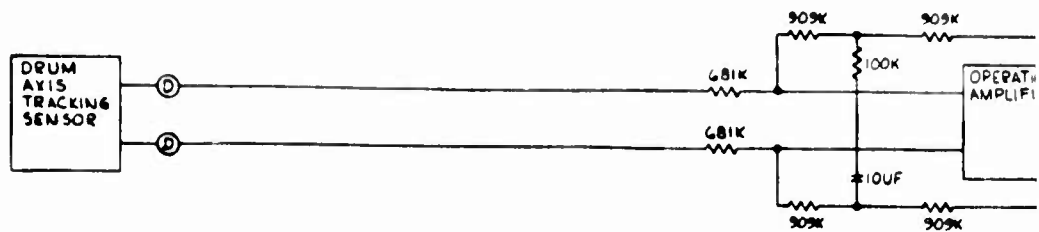

RATE AMPLIFIER

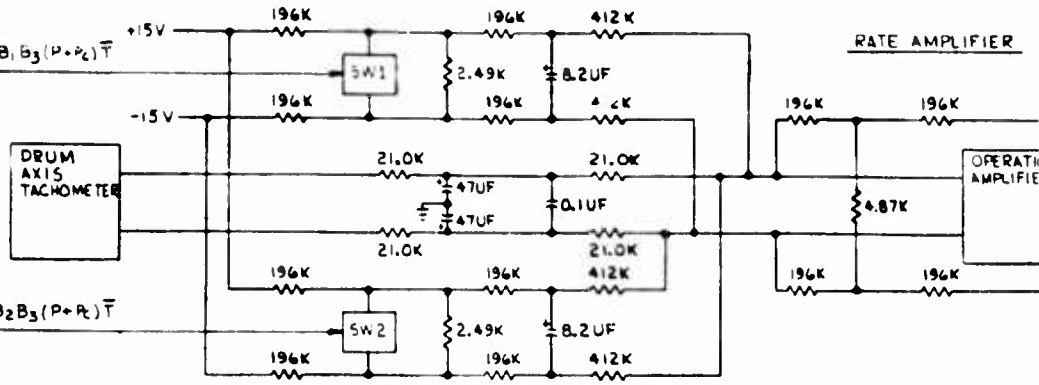

ACQUISITION LOGIC

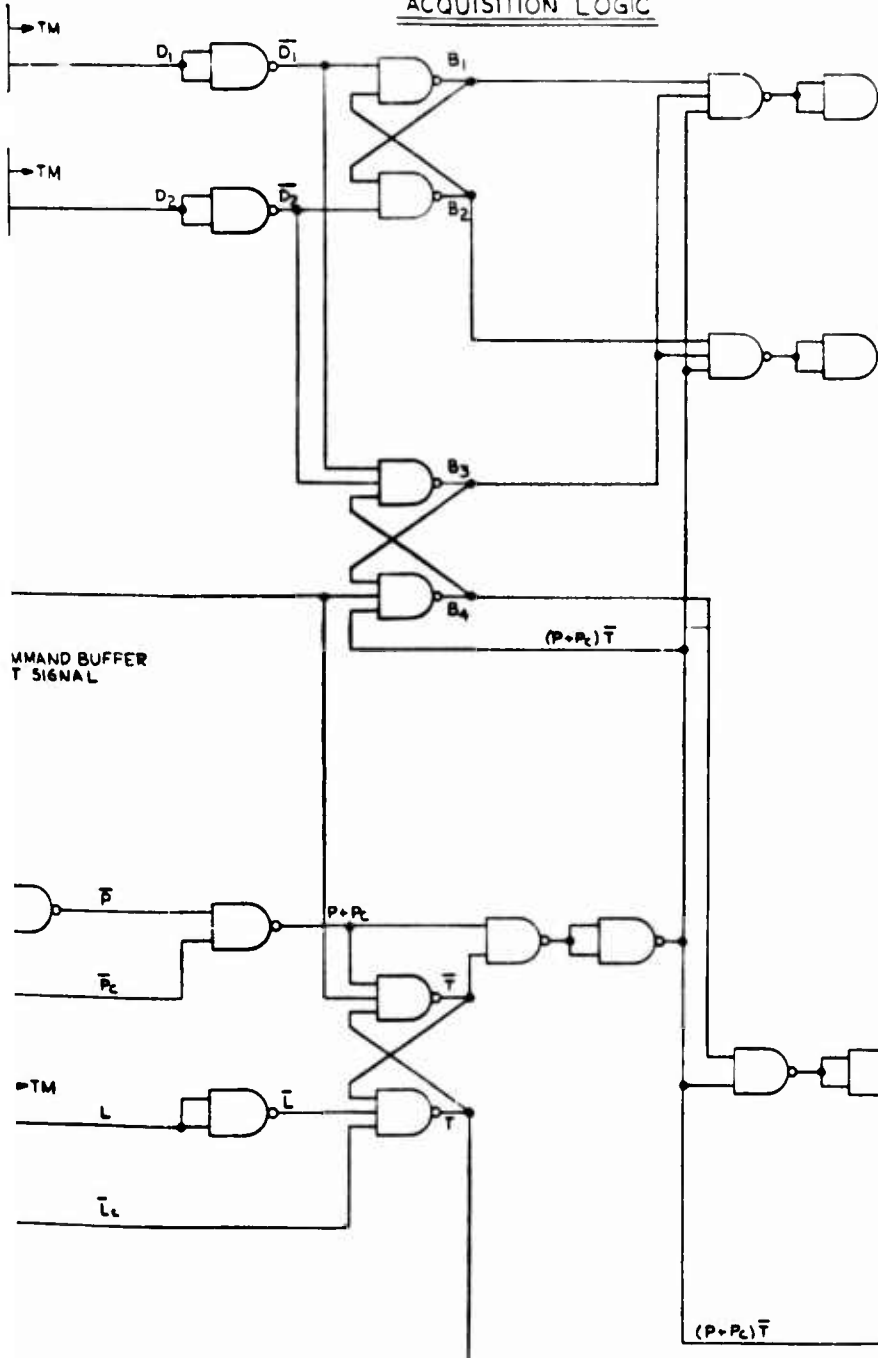

SUPPORT AXIS CHANNEL

STEERING AMPLIFIER



RATE AMPLIFIER

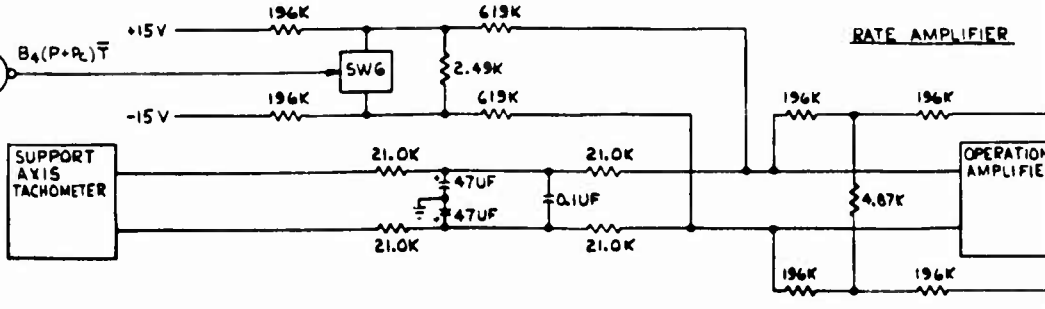

6

DRUM AXIS CHANNEL

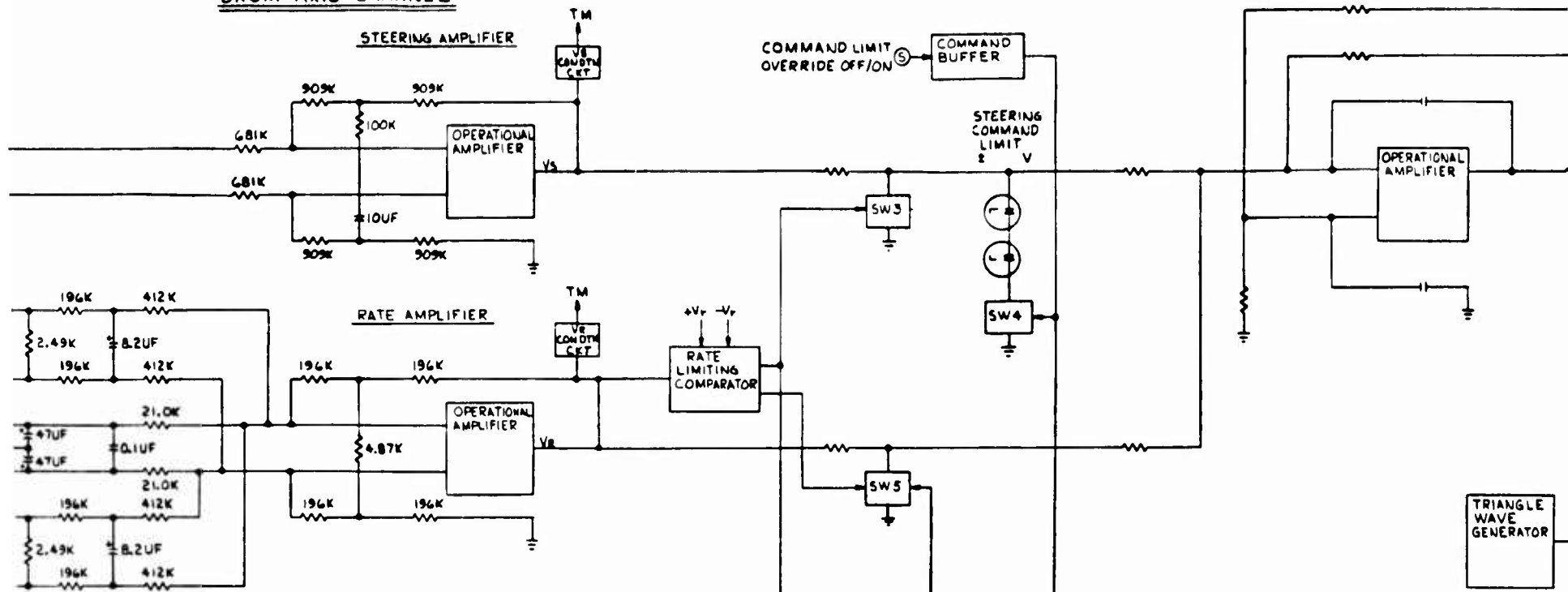

SUPPORT AXIS CHANNEL

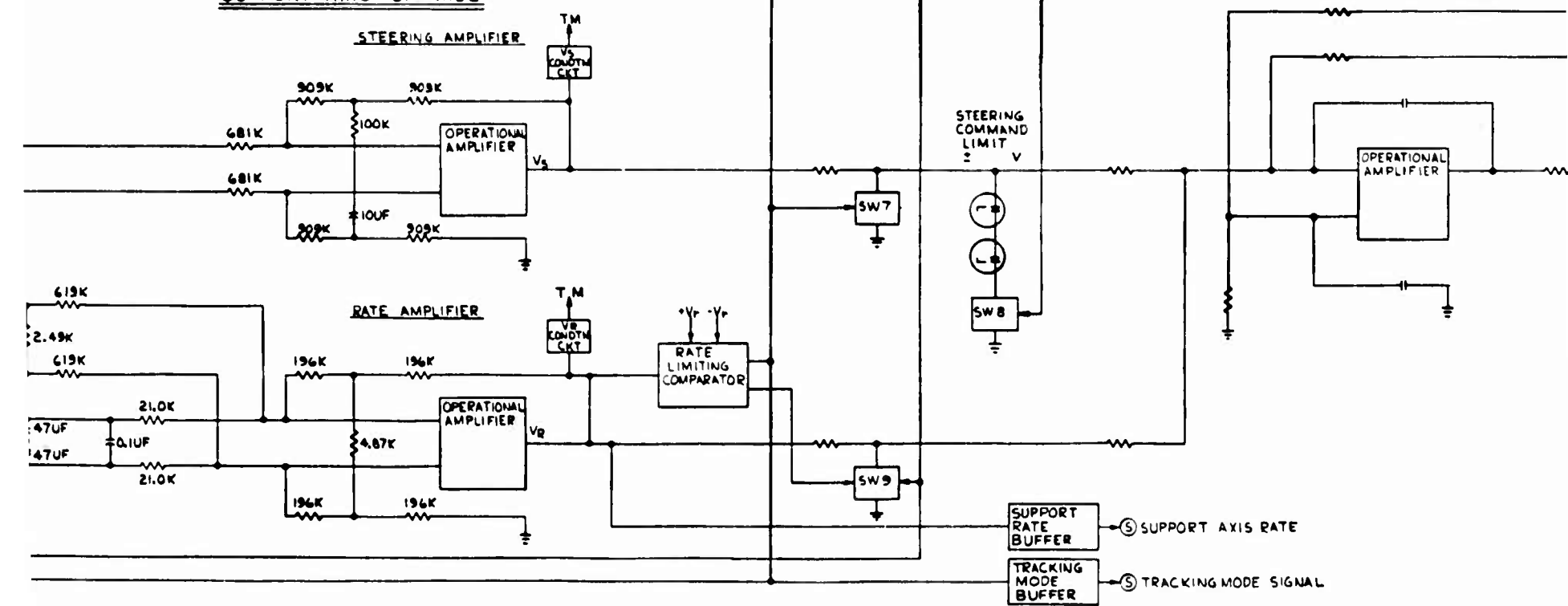

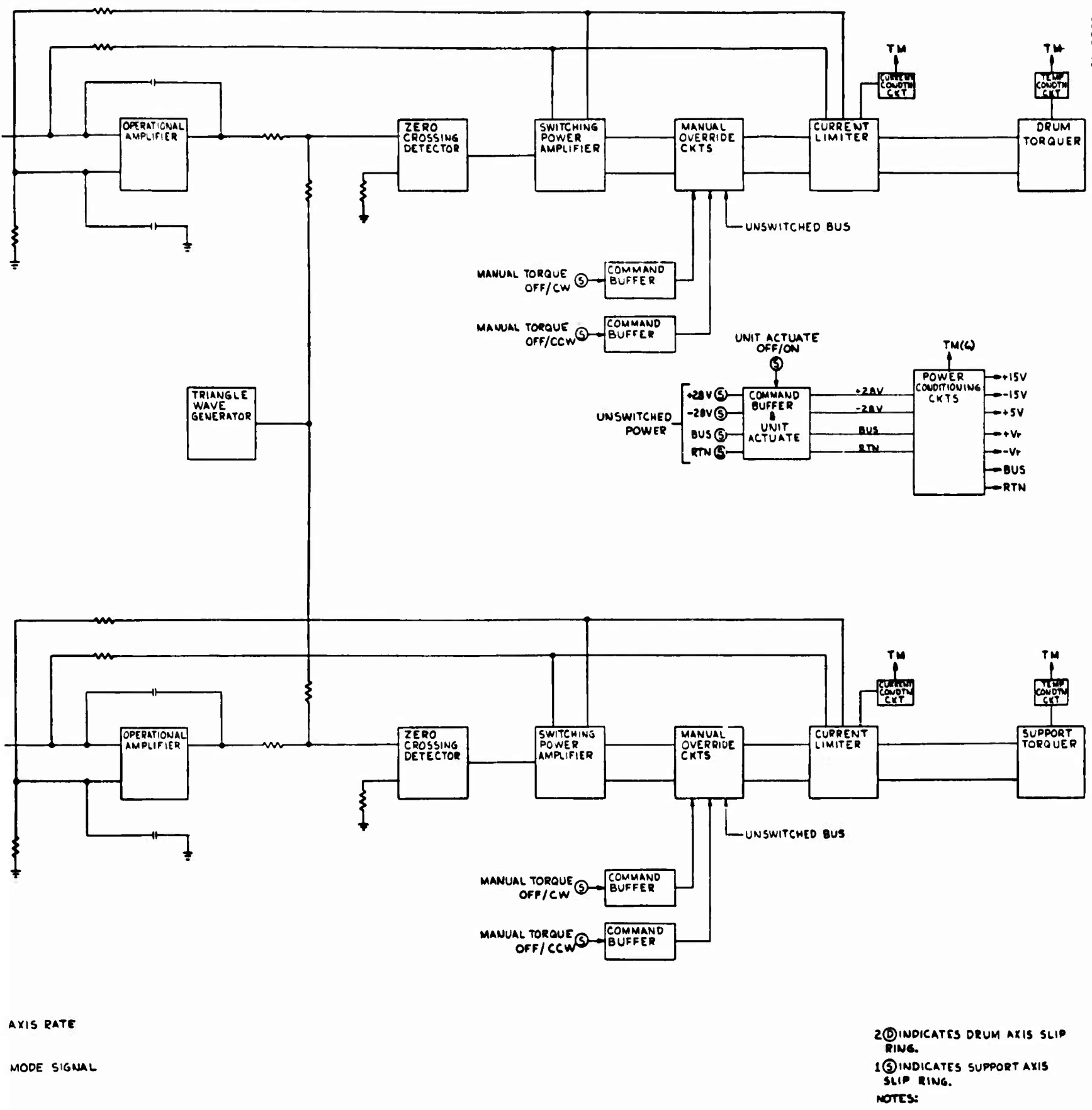

Figure 9. Control Electronics Unit Mechanization

- 7) Thermal-Vacuum Test
  - a) At high temperature extreme
  - b) At low temperature extreme
  - c) During warmup from cold soak
- 8) Ambient Functional Test

The model for this series of tests will consist of one orientation linkage mechanical assembly, as defined in assembly drawing number X3169041-100, modified as follows:

- Drum axis mechanism will be built to print, including the arm containing the deployment mechanism out to the FISCA interface, except that the number of data rings will be reduced to eight. External and internal thermal finishes are to be applied as specified, or if not yet specified at time of test article fabrication, they are to be applied according to best judgment at that time.
- Support axis mechanism will consist of basic structure (housing, shaft, and bearings) to print dimensions, but with internal components (motor, rate, sensor, sliprings, and brush blocks) represented by mass-equivalent dummies. Thermal finishes will be applied only to the external surfaces.

For all except the vibration tests, the portion of the drum axis arm outboard of the deployment joint will be removed, and the support-axis housing will be clamped to prevent rotation.

#### Ambient Functional Tests

The ambient functional test provides an initial baseline of performance and a measure of the extent to which performance may change as a result of exposure to specified environments. The initial test will be performed in a bench setup in a controlled atmosphere of dry nitrogen within the test enclosure. Subsequently, the test will be repeated following each environmental exposure, and during thermal-vacuum exposure. In these cases, the test may be performed on the bench in a dry nitrogen atmosphere, or in the test chamber either in vacuum or in an inert atmosphere obtained by backfilling the chamber with dry nitrogen.

#### Vibration Tests

Vibration tests will be made to the requirements of applicable documents and in accordance with standard laboratory practice. The orientation drive test assembly and the solar array subsystem attachment arm will be

assembled on the vibration test fixture with the array attachment arm hinged downward and retained securely in a bracket provided on the vibration fixture. The mounting will simulate the support provided the drive shaft in the spacecraft launch condition.

Ambient functional tests will be repeated after the vibration test. The bench setup with the test enclosure and a dry nitrogen atmosphere will be used. If there is no significant deterioration of performance from the preceding tests and performance meets specification requirements, the test series will continue.

### Shock Tests

Shock tests will be made to the requirements of applicable documents and in accordance with standard laboratory practice. The orientation drive test assembly and solar array subsystem attachment arm will be assembled on the vibration test fixture.

Ambient functional tests will be repeated after the shock test. The bench setup with the test enclosure and a dry nitrogen atmosphere will be used. If there is no significant deterioration of performance and performance meets specification requirements, the test series will continue.

### Thermal-Vacuum Tests

Thermal-vacuum tests will be made to the requirements of applicable documents and in accordance with standard laboratory practice. Heat will be applied to the assembly by means of heating pads arranged to simulate top and side sun aspects. In addition, runs will be made as the mechanism warms up following a soak without heat to ascertain if any binding occurs which might delay reacquisition upon emergence from eclipse. Functional tests will be performed under the best vacuum continuously attainable in a chamber capable of producing at least a vacuum of  $1 \times 10^{-6}$  Torr at normal temperature.

## TORQUER EVALUATION

### Motor Selection

Specific torque motors were examined for their characteristics under off-nominal operating conditions. These motors are the Inland T-3208, T-3204, and T-5134 models.

The T-3208 was originally selected on the basis of its nominal performance, but consideration of operation at a maximum allowable winding temperature of  $105^{\circ}\text{C}$  indicated a reduction in available torque to 0.8 lb-ft. While this is well over the maximum expected friction torque of 0.25 lb-ft, a minimum torque capacity of 1.2 lb-ft has been selected as a criterion to provide a conservative margin for coping with failure modes, such as a particle of debris in the bearings.

The T-3204 has the same diameter but a greater stack height; it will fit within the present orientation linkage for solar cell array (OLSCA) envelope with minimal modifications and can be wound to provide at least 1.2 lb-ft of torque under worst-case conditions. It is a relatively heavy motor, however.

The T-5134 produces the required torque for less power but is about 50 percent greater in diameter. An increase in mechanism housing weight of 1 to 2 pounds is involved with the larger diameter.

Results of these studies are summarized in Table V, where the effect of motor selection on the weight of the subsystem control electronics unit (CEU) and the system power supply (electronic conversion unit, ECU), has been included. The same battery is assumed for all cases, with the ECU size varied to recharge the batteries in proportion to the maximum motor and CEU loads. Nominal conditions are with motor windings at 25°C and bus potential (for those cases in which the unregulated bus provides motor excitation) at 28 volts. The worst-case failure mode (WCFM) is for windings at 105°C and bus at 24 volts, with direct manual command of the motor through relays. Torque and current correspond only for the nominal condition. For WCFM, the noncorresponding cases of lowest torque and highest current (and power) are listed.

The cases shown differ as follows:

- Case A — The T-3208 motor, operating from the system regulated power supply. Worst-case torque is below the criterion.
- Case B — The T-3208 motor, operating from the system power supply, and with winding altered to provide 1.5 lb-ft of WCFM torque. The power required in this mode leads to a heavy ECU.
- Case C — The T-3204 motor, operating from the system unregulated bus, with circuitry arranged to provide adequate torque under normal conditions, and full motor design torque capability under WCFM conditions. The load in the latter mode requires highly stressed switches and thermally limits the duration of operation. The ECU weight has dropped, however, due to relieving it of the direct motor load.
- Case D — The T-3204 motor, operating from the system unregulated bus, with current restricted to provide only 1.5 lb-ft of torque in the WCFM. For this 1.5 kw design, it produces a well-balanced system. A problem develops when expanding to a 2.5 kw system, however, as the desirable increase in motor torque output to maintain constant system dynamics then requires a significant increase in motor and system power. In the 2.5 to 5 kw range, two of these motors are required on each axis, leading to a significant weight increase as well as a load increase.

TABLE V. EFFECT OF TORQUER SIZE ON ELECTRONICS

Case	Motor Parameters					Total Power, watts	Electronics Weight, pounds			
	Diameter, inches	Weight, pounds	Torque, lb-ft*	Current, amperes	Power, watts		CEU	ECU	Battery	Total
A	4.09	2.4	1.2/0.80	3.3/5.4	74/141	91/157	6.5	17.5	37.8	61.8
B	4.09	2.4	1.5/1.5	3.9/12	112/302	165/351	6.5	33	37.8	77.3
C	4.09	5.0	1.3/2.8	6.8/20	36/468	90/586	7.25	12	37.8	57.1
D	4.09	5.0	1.5/1.5	3.9/5.3	50/137	81/155	7.25	7	37.8	52.1
E	6.25	4.8	1.9/1.2	2.0/3.8	45/128	57/139	7.25	7	37.8	52.1

\*Nominal/WCFM.

- Case E – The T-5134 motor with 28 volt winding, operating from the system unregulated bus. This unit has a design torque output of 2.7 lb-ft, but, with this winding, and considering switch power drops, etc., it is underdriven. Power requirements are, therefore, low, with adequate to excellent torque for the present application. With different windings, this motor will drive systems up to about 3 kw at reasonable power levels.

### Mechanism Effects

General layout of the mechanism is similar whether 4- or 6-inch diameter torquers are used. Because the larger diameter units are thinner, the housing can be shorter so that the increase in diameter does not lead to a proportional increase in weight.

A general dimensional comparison is made in Table VI. Here the mechanism weight (including motors) is shown rather than that of the electronics as in the previous section. While, for the 1.5 kw system, the larger diameter mechanism is slightly heavier, its configuration is inherently better suited to adaptation to larger systems, as the increased torque requirements can be met at a reasonable power level by employing a single higher-rated 51XX-series motor per axis rather than requiring use of two 32XX-series units per axis. The single motor approach in the larger systems will employ a split winding, with separate CEUs driving each half, thereby incorporating effective redundancy at minimum weight penalty.

TABLE VI. EFFECT OF TORQUER SIZE ON MECHANISM

Torquer (Number per axis)	1.5 kw		5 kw	
	T-3204 (1)	T-5134 (1)	T-3204 (2)	T-5135 (1)
Torquer diameter, inches	4.09	6.25	4.09	6.25
Torquer weight (maximum torque) per axis, pounds	5.0 (1.5)	4.8 (2.7)	10.0 (5.6)	6.4 (4.0)
Mechanism weight, (including torquers), pounds	35.4	36.9	45.4	40.1
Mechanism height, inches	23.2	21	23.2	21
Mechanism span, inches	16	12.6	16	12.6

The layout has now been standardized to incorporate 33 data brushes, sufficient to handle arrays on either one or both sides. Space for four power brushes is provided, sufficient to handle 5 kw, although only two will actually be installed in the present 1.5 kw unit.

### Summary

As a result of the above considerations, the 6-inch diameter Inland T-5134 motor has been selected for the 1.5 kw flight model orientation mechanism. This selection allows a net reduction in system weight (mechanism plus affected electronics) of 8.2\* pounds and provides a basic configuration which can be extended to a 5 kw system without major change and with an increased weight reduction advantage. Further weight reduction is possible, even in the 1.5 kw case, by sizing the battery to the reduced power requirement of the T-5134 motor. This was not done, however, since qualified batteries have been selected for the experimental flight; changing the size would entail significant increases in program cost for engineering and qualification of a specifically sized battery.

### MOMENTUM CANCELLATION

Specific features of a momentum cancellation subsystem study, to be performed during the first 6 months of 1969, have been defined as follows:

#### 1) Problem Study

- a) Provide or develop the analysis and/or simulation techniques required to define LRSCA orientation link steering torque-induced disturbances to either three-axis stabilized or spin-stabilized spacecraft in circular earth orbits of any inclination at altitudes from 400 to 20,000 n.mi.
- b) Employing the Agena D as a model for a three-axis stabilized vehicle, and a modified Hughes HS-308 as a model for a spin-stabilized vehicle, and using the techniques of item a above, determine the array steering torque requirements, the attitude perturbations induced by these torques on the actively controlled Agena and the spin-stabilized HS-308, and the degree to which such perturbations can be reduced and the attitude control gas conserved by use of a single momentum-storage flywheel.
- c) Define the required physical and functional control characteristics of such reaction wheels.

---

\*Not included in weight summary in Table II.

## 2) Subsystem Definition

- a) Examine various candidate motor systems for driving the reaction wheel at the rates and accelerations required, and justify the method of choice.
- b) Identify all significant components of a momentum cancellation subsystem employing a single reaction wheel, their interconnections, and interfaces with other subsystems of a LRSCA/Agema system.

## 3) Electronic Drive

- a) Examine the problems involved in driving a reaction wheel of the physical characteristics and to the performance requirements defined in the above.
- b) Design an electronic drive which will satisfy these requirements for a period of 5 years with a reliability of 0.95.
- c) Design, fabricate, and test development hardware as required to assist the design effort and provide a high degree of confidence that the design will survive reasonable qualification environments.
- d) Document the design in a Design Specification for an Electronic Drive for a Momentum Reaction Wheel.

## ORIENTATION SUBSYSTEM SPECIFICATION

The orientation linkage subsystem specification was not prepared as an independent document but as a section of the LRSCA system specification. Pertinent preliminary material was prepared and submitted as required during this reporting period. Detail and refinements will be incorporated during the coming period.

## PLANS FOR NEXT QUARTER

Primary effort during the next quarter will be devoted to the following activities:

- 1) Continued detailed design of the electronic control unit
- 2) Preparation of detailed drawings of the mechanism
- 3) Procurement and fabrication of the development test model and detailed test planning
- 4) Stress and thermal analysis of the design

## SECTION VI

### POWER SUBSYSTEM

During the second quarter, various methods of terminating battery charge were investigated. Since it is necessary to charge the battery at a relatively high rate (C/6) for low earth orbits in order to enable replenishment of the battery energy during the sunlight portion of eclipse orbits, the problem of overcharge is critical. A method had to be selected to effectively charge the battery at various temperatures. The method selected is a two-phase system utilizing a high current recharge and subsequent feedback controlled trickle charge. The feedback control of the battery terminal voltage with active biasing will be a function of battery temperature. An additional circuit will be employed to initiate further reduction of the trickle charge current when the battery temperature exceeds 121°F.

During the next quarter, further investigation of the battery charge termination techniques will be made and supported by laboratory experimentation before proceeding with the detailed design.

## SECTION VII

### INSTRUMENTATION SUBSYSTEM

#### PURPOSE AND GENERAL REQUIREMENTS

The primary purpose of the instrumentation subsystem is to obtain electrical, mechanical, and thermal data from the LRSCA experiment to evaluate its performance during flight and test. A secondary purpose is to analyze possible equipment failure, malfunction, or degradation during flight and test.

To achieve these goals, sensors are provided to measure the required performance parameters. Associated conditioning circuits and commutators are also required to convert the sensor output signals into a format suitable for interfacing with the launch vehicle telemetry subsystem.

#### COMPOSITE AIR/GROUND TELEMETRY LINK

The LRSCA instrumentation subsystem is designed to be compatible with the Air Force space-ground link subsystem (SGLS). Figure 10 is a functional block diagram of the airborne portion of the telemetry link.

The instrumentation signals on the drum mechanism and orientation linkage are multiplexed in pulse amplitude modulation (PAM) commutators prior to application to the vehicle FM subcarrier voltage-controlled oscillators (VCO). This was done to minimize the number of sliprings required on the LRSCA and results in PAM/FM/FM telemetry signals transmitted to the ground station. A 45-word, 180-sample-per-second commutator was selected in each instance to accommodate the required number of channels and allow supercommutation of the accelerometer and strain gage measurements.

The instrumentation signals processed on the orbital equipment rack are hard-wired directly to vehicle commutator switches by means of an interconnecting cable. These signals will be transmitted either as PAM/FM/FM or PCM/FM/FM, as the launch vehicle integrator chooses.

The ground station must provide a receiver, frequency discriminators, decommutators, and output recording devices to provide a readout for each individual measurement.

#### PROGRESS DURING SECOND QUARTER

A preliminary design specification for the instrumentation subsystem was completed and distributed to all design activities. It describes in detail the requirements of all measurements performed on the LRSCA experiment.

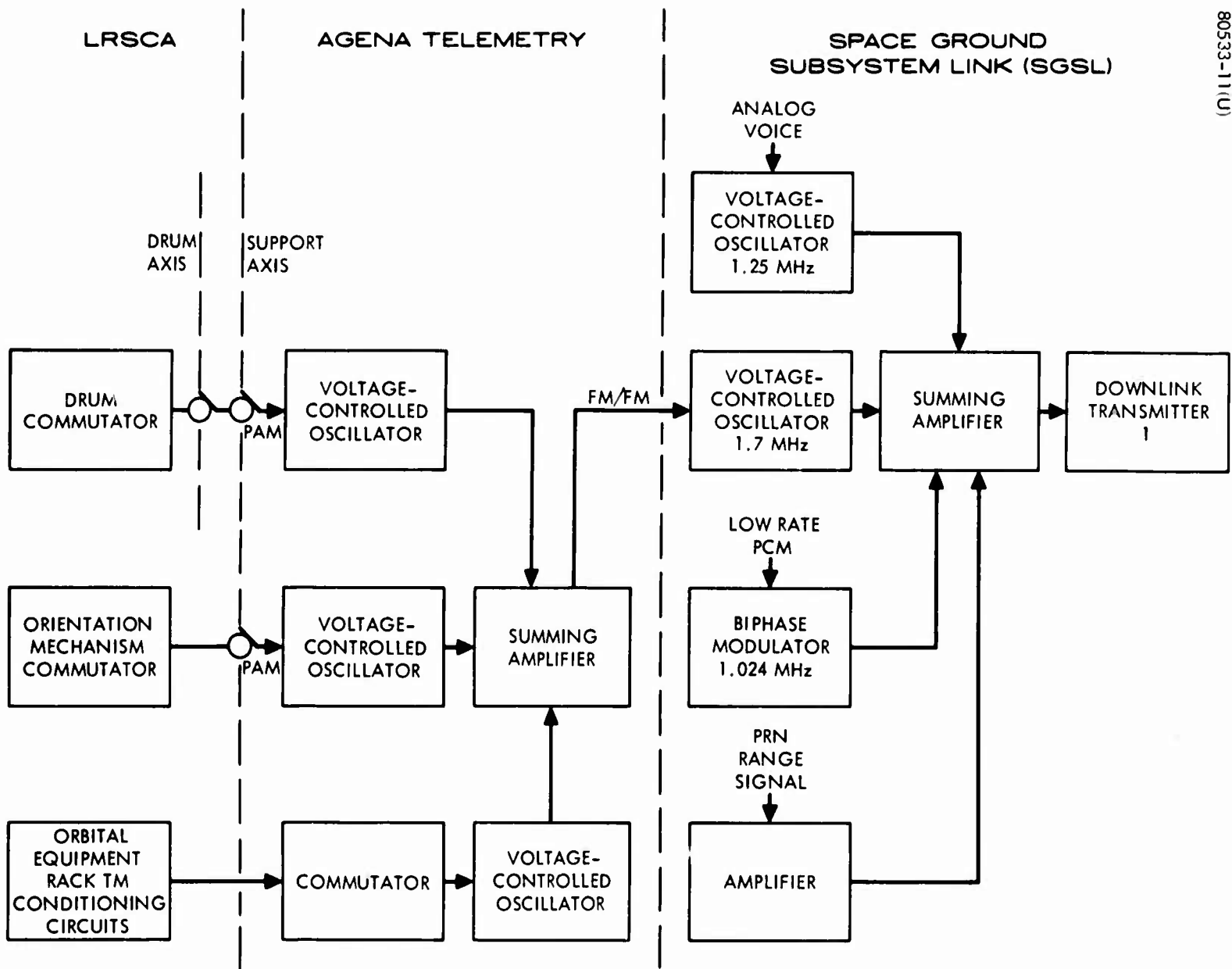

80533-11(U)

Figure 10. Telemetry Subsystem Block Diagram

In many instances, the sensors and associated conditioning circuits are an integral part of another subsystem; however, all measurement requirements are defined in the instrumentation subsystem portion of the design specification. The following items have been specifically designated as control items of the instrumentation subsystem:

- 1) Instrumentation conditioning unit (ICU)
- 2) Solar array 1 current sensor
- 3) Solar array 2 current sensor
- 4) STEM strain gage amplifier
- 5) Spreader bar strain gage amplifier
- 6) Orientation linkage PAM commutator
- 7) Solar array PAM commutator
- 8) STEM tip inboard accelerometer (V-axis)
- 9) STEM tip inboard accelerometer (W-axis)
- 10) STEM tip outboard accelerometer (V-axis)
- 11) Drum mechanism accelerometer (V-axis)
- 12) Drum mechanism accelerometer (W-axis)

A Systron Donner 4310 force balance servo accelerometer was initially selected to measure acceleration levels at the drum mechanism and STEM boom tips of array panel 1. This resulted in a total instrumentation weight of approximately 2 pounds at the boom tips for the three accelerometers and one strain gage plus associated mounting brackets. This was deemed excessive; therefore, a smaller Systron Donner 4311 was selected to reduce the instrumentation weight at the boom tip to approximately 1 pound.

A temperature sensor accuracy requirement of  $\pm 5^{\circ}\text{F}$  has been established (including conditioning circuitry). This requires a source of voltage whose accuracy must be at least  $\pm 0.5$  percent. The 28 volt source available from the power conditioning unit has an accuracy of only  $\pm 3$  percent and therefore is inadequate. Since an accurate source of 15 volts excitation is required for the sun sensors, it was decided to improve its accuracy from 1 percent to 0.5 percent and use it to condition temperature sensors located on the solar array and orientation linkage subsystems.

A number of telemetry commutator reassignments were made. Current telemetry measurements are itemized in Tables VII, VIII, and IX.

TABLE VII. SOLAR ARRAY COMMUTATOR  
TELEMETRY MEASUREMENTS

<u>Data Channel</u>	<u>Function</u>
A-1	Zero calibration
A-2	Full-scale calibration
A-3	STEM tip inboard accelerometer (V-axis)
A-4	STEM tip inboard accelerometer (W-axis)
A-5	STEM tip outboard accelerometer (V-axis)
A-6	Drum platform accelerometer (V-axis)
A-7	Drum platform accelerometer (W-axis)
A-8	Solar array 1 temperature
A-9	Solar array 2 temperature
A-10	Solar array motor temperature
A-11	Solar array voltage
A-12	Array position indicator (pulse count)
A-13	Spreader bar temperature
A-14	Solar array fully extended
A-15	Solar array fully retracted
A-16	Spreader bar strain gage
A-17	STEM strain gage
A-18	STEM tip inboard accelerometer (V-axis)
A-19	STEM tip inboard accelerometer (W-axis)
A-20	STEM tip outboard accelerometer (V-axis)
A-21	Drum platform accelerometer (V-axis)
A-22	Drum platform accelerometer (W-axis)

TABLE VII. SOLAR ARRAY COMMUTATOR  
TELEMETRY MEASUREMENTS (Concluded)

<u>Data Channel</u>	<u>Function</u>
A-23	Solar array 1 current
A-24	Solar array 2 current
A-25	Sun present sensor cell 1A
A-26	Sun present sensor cell 1B
A-27	Sun present sensor cell 1C
A-28	Sun present sensor cell 1D
A-29	Sun present sensor cell 2A
A-30	Sun present sensor cell 2B
A-31	Sun present sensor cell 2C
A-32	Sun present sensor cell 2D
A-33	STEM tip inboard accelerometer (V-axis)
A-34	STEM tip inboard accelerometer (W-axis)
A-35	STEM tip outboard accelerometer (V-axis)
A-36	Drum platform accelerometer (V-axis)
A-37	Drum platform accelerometer (W-axis)
A-38	Solar array subassembly released and locked
A-39	Spreader bar strain gage
A-40	STEM strain gage
A-41	Spare
A-42	Spare
A-43	Spare
A-44	Synchronization
A-45	Synchronization

TABLE VIII. ORIENTATION LINKAGE COMMUTATOR  
TELEMETRY MEASUREMENTS

<u>Data Channel</u>	<u>Function</u>
B-1	Zero calibration
B-2	Full-scale calibration
B-3	Sun present signal
B-4	Acquisition sensor, positive
B-5	Acquisition sensor, negative
B-6	Tracking sensor, lockon cell
B-7	Tracking sensor, drum axis error
B-8	Tracking sensor, support axis error
B-9	Sun sensor excitation, +15 volts dc
B-10	Sun sensor excitation, -15 volts dc
B-11	Drum axis torquer current
B-12	Support axis torquer current
B-13	Control electronics unit, +5 volts dc
B-14	Control electronics unit, +28 volts dc
B-15	Control electronics unit, -28 volts dc
B-16	Spare
B-17	Drum axis tachometer voltage
B-18	Support axis tachometer voltage
B-19	Drum axis torquer temperature
B-20	Support axis torquer temperature
B-21	Drum axis tachometer temperature
B-22	Support axis tachometer temperature

TABLE VIII. ORIENTATION LINKAGE COMMUTATOR  
TELEMETRY MEASUREMENTS (Concluded)

<u>Data Channel</u>	<u>Function</u>
B-23	Control electronics unit temperature A
B-24	Control electronics unit temperature B
B-25	Control electronics unit temperature C
B-26	Control electronics unit temperature D
B-27	Drum axis structure temperature
B-28	Drum axis brush temperature
B-29	Drum axis bearing temperature
B-30	Support axis structure temperature
B-31	Support axis brush temperature
B-32	Support axis bearing temperature
B-33	Torquer voltage
B-34	Spare
B-35	Spare
B-36	Spare
B-37	Spare
B-38	Spare
B-39	Spare
B-40	Spare
B-41	Spare
B-42	Spare
B-43	Spare
B-44	Synchronization
B-45	Synchronization

TABLE IX. POWER CONDITIONING UNIT  
TELEMETRY MEASUREMENTS

<u>Data Channel</u>	<u>Function</u>
C-1	LRSCA unregulated voltage
C-2	Battery 1 voltage
C-3	Battery 2 voltage
C-4	Battery 1 charge current
C-5	Battery 2 charge current
C-6	Regulated voltage (+28 volts)
C-7	Regulated voltage (-28 volts)
C-8	Regulated current (+28 volts)
C-9	Regulated current (-28 volts)
C-10	Solar array motor current
C-11	Inverter A voltage
C-12	Inverter B voltage
C-13	400 Hz inverter output voltage
C-14	Battery 1A temperature
C-15	Battery 1B temperature
C-16	Battery 1C temperature
C-17	Battery 1D temperature
C-18	Battery 2A temperature
C-19	Battery 2B temperature
C-20	Battery 2C temperature
C-21	Battery 2D temperature
C-22	Spare
C-23	Spare
C-24	Spare
C-25	Spare

## PROBLEM AREAS

Telemetry interfaces with the launch vehicle have not been defined. It is necessary that commutator frame size and sample rate be compatible with the launch vehicle telemetry subsystem and ground data processing equipment. This affects the number of measurements that can be made and the size and weight of the commutators. The commutator that has been selected appears to be reasonable at this time, but it is still a tentative choice.

## SECTION VIII

### TEST

The principal progress during this quarter in the test area is described below.

#### WATER TABLE

To facilitate the extension and retraction of the full-size solar panels, low-friction water tables have been designed and are being fabricated. The test setup will consist of two large tables placed one on either side of the solar panel drum. The tables will provide a water surface approximately 1.5 inches deep, upon which the panels will be floated, and will be large enough to accommodate the complete system in the deployed conditions. The drum mechanism will be mounted between the pair of tables so that each panel will slide out over a table, supported at intervals on styrofoam floats in a shallow fiberglass pan of water. The table and water pan will be approximately 9 feet by 18 feet (36 feet for the pair) plus float trays.

As the mechanism is deployed and retracted, the position of the booms and panels will be observed against a 2 by 2 inch grid of black 0.25 inch reference lines against a white background. Either continuous or lapse time motion picture record, as required, will be made by a movie camera mounted or suspended above each table.

Alternate designs considered for the low-friction table included use of a teflon coated surface, rollers, rollers on a lateral endless belt, and a vertical deployment configuration with counterbalances. The water table method exhibited the lowest frictional forces.

#### STATUS

The two tables have been assembled, and installation of the fiberglass lining, waterproofing, and painting are under way. Layout of the test area is being studied with reference to facilities and equipment needed. Methods of supporting the camera under consideration include the use of structures standing on the floor straddling the table or of structures or cables suspended from the ceiling of the room. The latter arrangement would be advantageous in that it would leave the floor area around the tables clear, but the structure of the building may not lend itself to this configuration.

#### PLANNED ACTIVITY FOR THIRD QUARTER

During the next quarter, the test area will be established complete with water tables. A feasibility model of the solar array (FISCA), developed under a previous AF contract, has been requested for use in checking out the operation of the water tables. This facility will be available for demonstration or development testing of the solar array subsystem.

## SECTION IX

### RELIABILITY

The principal reliability activities for the quarter include the apportionment of reliability requirements to the control item level and the analysis, with the design engineers, of specific design features, components application, etc., to maximize control item reliability as the detail design evolves. The major efforts in this respect were analyses of the orientation mechanism and the extendible boom actuator assemblies.

The reliability of critical devices was determined through in-house testing and literature research. Using these data, a reliability apportionment has been made (Figure 11). The number in the block shows the reliability that the particular subsystem must attain in order to meet the overall specified 1.5 kw system reliability of 0.65 for a 1-year operation. Preliminary reliability calculation of the baseline design has indicated that the system reliability will significantly exceed the 0.65 specified. Continuous close support of the product design engineers will be maintained, and reliability predictions will be periodically updated as new data become available. These data will be evaluated to spotlight areas of the system where improvement should be made, especially as the design of a 5 kw 3-year system is initiated.

#### SUBSYSTEM RELIABILITY APPORTIONMENT



80533-12(U)

#### RELIABILITY APPORTIONMENT

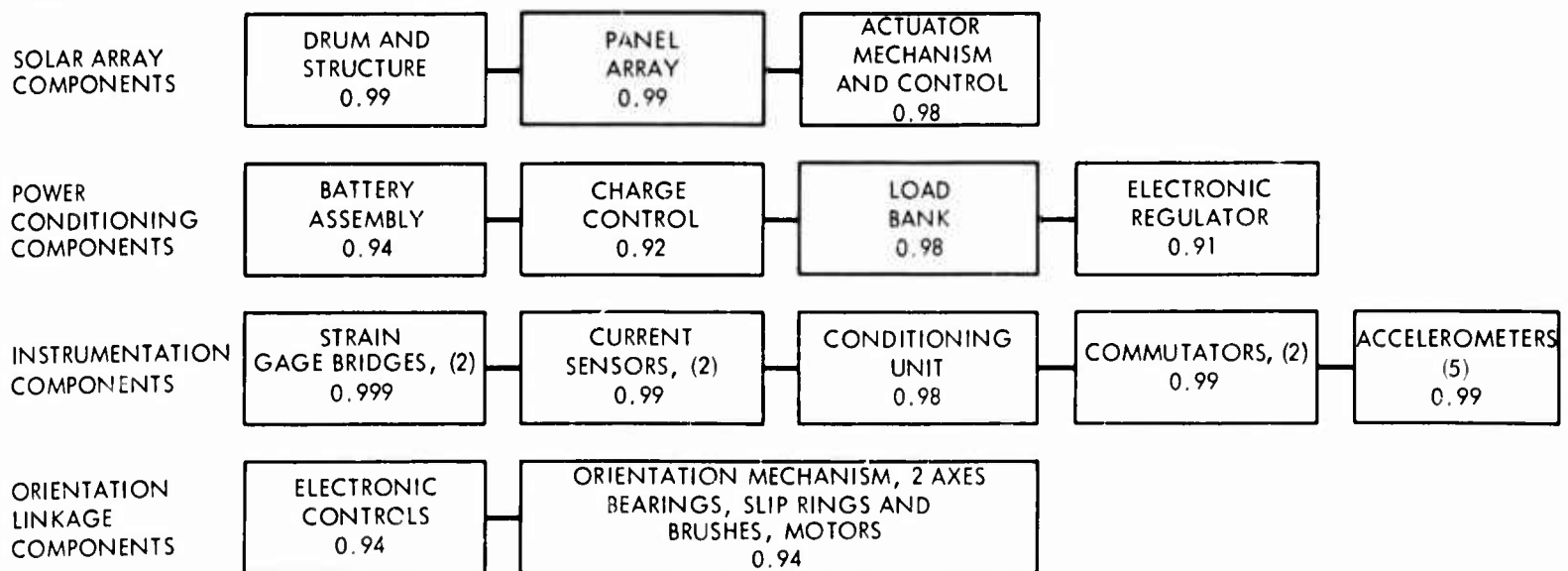

Figure 11. Reliability Apportionment for 1.5 kw Design  
System reliability goal 0.65 for 1 year

DOCUMENT CONTROL DATA - R & D

(Security classification of title, body of abstract and indexing annotation must be entered when the overall report is classified)

1. ORIGINATING ACTIVITY (Corporate author) Hughes Aircraft Company Space Systems Division El Segundo, California		2a. REPORT SECURITY CLASSIFICATION Unclassified	
		2b. GROUP Not Applicable	
3. REPORT TITLE SECOND QUARTERLY TECHNICAL PROGRESS REPORT - LARGE RETRACTABLE SOLAR CELL ARRAY			
4. DESCRIPTIVE NOTES (Type of report and inclusive dates) Second Quarterly Technical Progress Report; 27 September 1968 through 27 December 1968			
5. AUTHOR(S) (First name, middle initial, last name) George Wolff Edward O. Felkel			
6. REPORT DATE January 1969		7a. TOTAL NO. OF PAGES 54 Printed	7b. NO. OF REFS None
8a. CONTRACT OR GRANT NO. F 33615-68-C-1676		9a. ORIGINATOR'S REPORT NUMBER(S) 68 (22)-10491/B3532-004	
b. PROJECT NO. 682J		9b. OTHER REPORT NO(S) (Any other numbers that may be assigned this report) SSD 80533R	
c.			
d.			
10. DISTRIBUTION STATEMENT DDC Cameron Station Alexandria, Virginia 22314			
11. SUPPLEMENTARY NOTES Not Applicable		12. SPONSORING MILITARY ACTIVITY Air Force Aero Propulsion Laboratory APIP-2 Wright-Patterson AFB, Ohio 45433	
13. ABSTRACT The main activity on the Large Retractable Solar Cell Array (LRSCA) program during the second quarterly reporting period consisted of design and analyses of major subsystem components, test and development planning, design and fabrication of a solar cell array test bed, preparation of a preliminary reliability apportionment, release of a preliminary instrumentation subsystem design specification, negotiation of the extendible boom actuator unit subcontract with SPAR Aerospace Products of Canada, Ltd., and preparation of the Preliminary System Design Specification.  A major program redirection occurred during this reporting period - the use of GFE (8-mil thick, 2 x 2 cm) cells rather than the standard (12 to 14 mil thick, 2 x 2 cm) cells previously planned. The same directive authorized a study to determine momentum-storage wheel requirements to compensate for the disturbing torques resulting from orientation mechanism maneuvers.			

