

UNCLASSIFIED

AD NUMBER

AD846155

LIMITATION CHANGES

TO:

Approved for public release; distribution is unlimited.

FROM:

Distribution authorized to U.S. Gov't. agencies and their contractors; Critical Technology; NOV 1968. Other requests shall be referred to Defense Advanced Research Projects Agency, TIO, Washington, DC. This document contains export-controlled technical data.

AUTHORITY

arpa memo, 12 jan 1970

THIS PAGE IS UNCLASSIFIED

AD846155

SECOND QUARTERLY TECHNICAL REPORT
MONTANA LARGE APERTURE SEISMIC ARRAY

November 1968

DIRECTORATE OF PLANNING AND TECHNOLOGY
ELECTRONIC SYSTEMS DIVISION
AIR FORCE SYSTEMS COMMAND
UNITED STATES AIR FORCE
L. G. Hanscom Field, Bedford, Massachusetts

Sponsored by: Advanced Research Projects Agency
Washington, D. C.

ARPA Order No. 800

This document is subject to special export controls and each transmittal to foreign governments or foreign nationals may be made only with prior approval of Hq ARPA (TIO).

JAN 21 1969

(Prepared under Contract No. F19628-68-C-0401 by Philco-Ford Corporation, Education and Technical Services Division, 214 North 30th, Billings, Montana 59101.)



ESD-TR-68-428

SECOND QUARTERLY TECHNICAL REPORT
MONTANA LARGE APERTURE SEISMIC ARRAY

November 1968

DIRECTORATE OF PLANNING AND TECHNOLOGY
ELECTRONIC SYSTEMS DIVISION
AIR FORCE SYSTEMS COMMAND
UNITED STATES AIR FORCE
L. G. Hanscom Field, Bedford, Massachusetts

Sponsored by: Advanced Research Projects Agency
Washington, D. C.

ARPA Order No. 800

This document is subject to special export controls and each transmittal to foreign governments or foreign nationals may be made only with prior approval of Hq ARPA (TIO).

(Prepared under Contract No. F19628-68-C-0401 by Philco-Ford Corporation, Education and Technical Services Division, 214 North 30th, Billings, Montana 59101.)



FOREWORD

This research is supported by the Advanced Research Projects Agency. The Electronics Systems Division technical project officer for Contract No. F19628-68-C-0401 is Lt. J. R. Todd (ESLE). This report covers the period from 1 August 1968 through 31 October 1968.

This technical report has been reviewed and is approved.

William R. Lauterbach
Lt. Colonel, USAF
Chief, Seismic Array Program Office
Development Engineering Division
Directorate of Planning and Technology

ABSTRACT

This report concerns technical activity at the Montana Large Aperture Seismic Array (LASA). IBM System/360 Model 44 computer programming to complete the Montana segment of the Interim Integrated Signal Processing System (IISPS) and system testing are discussed. Array work described includes installation of attenuated short-period and long-period seismic signal channels and completion of the Large Aperture Microbarograph Array (LAMA). A report on the experiment which utilized the LASA for early warning of the occurrence of potentially destructive earthquakes concludes that the reaction time for reporting large event parameters is on the order of one-half hour and that currently employed LASA data analysis techniques are adequate. A report on oil well drilling noise confirms preliminary conclusions which state that no effect on LASA data analysis from analog sum signals is evident unless drilling occurs within about two miles of the center hole sensor. Measured short-period seismic channel phase shift statistics are reported. Also provided are statistics on the seismic events reported in the Seismo Bulletin, maintenance of the equipment, and general operation of the Data Center.

TABLE OF CONTENTS

SECTION	TITLE	PAGE
I	INTRODUCTION	1
II	DEVELOPMENT AND IMPROVEMENT OF LASA	3
	2.1 IISPS	3
	2.1.1 LASAPS	3
	2.1.2 LASAPS Backup System	7
	2.2 Array	7
	2.2.1 Attenuated Short-Period Seismic Signal Channel, Array	7
	2.2.2 Attenuated Long-Period Seismic Signal Channel, C2	8
	2.2.3 Large Aperture Microbarograph Array (LAMA)	11
	2.3 Miscellaneous Effort	33
	2.3.1 Large Event Alert Experiment	33
	2.3.2 Well Drilling Noise Effect on LASA Data Analysis	44
	2.3.3 Short-Period Seismic Signal Channel Phase Measurement	55
	2.3.4 Microbarograph Data Recording	64
	2.3.5 Mark Products L-3A Seismometer Evaluation	73
	2.3.6 USGS High Explosive Calibration of the LASA	73
III	SEISMIC SIGNAL ANALYSIS	77
	3.1 Statistics	77
IV	MAINTENANCE	85
	4.1 Array	85
	4.2 Data Center	88
V	OPERATION	91
	5.1 Data Center	91
	5.1.1 Computer Operation	91
	5.1.2 Library Operation	95
	APPENDIX A: LASAPS Backup System Tape Format	99
	REFERENCES	104

LIST OF FIGURES

		PAGE
2.1	LASAPS High Rate Tape Control	5
2.2	Dual-Channel WHV Panel	9
2.3	Standard LASA WHV Panel	9
2.4	Two-Channel WHV Electronics Block Diagram	10
2.5	Attenuated Long-Period Seismic Signal Channel Diagram	12
2.6	Large Aperture Microbarograph Array	13
2.7	LAMA Geometry and Sensor Locations	14
2.8	LTV-6 Components in Insulated Box	16
2.9	LTV-6 CTH Installation	16
2.10	LTV-6 Equipment Block Diagram	17
2.11	Acoustic Step Calibrator	18
2.12	Acoustic Step Calibrator Diagram	18
2.13	Microbarograph Frequency Response A	19
2.14	LTV-6 SEM Microbarograph Channel Block Diagram	21
2.15	LTV-6 Pipe Array Dimensions	22
2.16	LTV-6 Pipe Array Tee Junction	23
2.17	CTH Acoustical Inlet	23
2.18	LTV-6 Pipe Array Culvert Crossing	24
2.19	LTV-6 Pipe Array Acoustical Orifice	24
2.20	LTV-6 with 12-inch Vent Tube	25
2.21	Microbarograph Frequency Response B	26
2.22	ESSA Equipment Block Diagram	28
2.23	ESSA Transducer Can	29
2.24	ESSA Oscillator Mounted in Can	29
2.25	ESSA Transducer Can Installation	30
2.26	ESSA Power Supply and Discriminator Installation	30
2.27	Microbarograph Frequency Response C	31
2.28	ESSA Portable Calibrator	32
2.29	ESSA Calibration System Diagram	32
2.30	ESSA Pipe Array Dimensions	34
2.31	ESSA Array Cross Junction	35
2.32	ESSA Array Tee Junction	35
2.33	ESSA Array Culvert Crossing	36
2.34	ESSA Array Acoustical Orifice	36
2.35	Plot of Events Causing LASA Earth Motion Near and in Excess of the Large Event Threshold	37
2.36	Site D2 Sensor Locations with Respect to Well #2	46
2.37	Power Spectral Density Plot of D2-53 before and during Drilling Activity	47
2.38	Power Spectral Density Plot of D2-73 before and during Drilling Activity	48
2.39	Power Spectral Density Plot of D2-75 before and during Drilling Activity	49
2.40	Power Spectral Density Plot of D2-82 before and Drilling Activity	50
2.41	Power Spectral Density Plot of D2-84 before and during Drilling Activity	51
2.42	Power Density at 4.2 Hz before and during Drilling	52

LIST OF FIGURES - Concluded

	PAGE
2.43 Effect of Butterworth Filter on Drilling Noise at D2 Sensors 73, 82 and 75	53
2.44 Amplitude Characteristic of LASA Off-Line Filter	54
2.45 LASA Short-Period Seismic Signal Channel	57
2.46 Channel Phase Shift Distribution at 1 Hz (384 Channels)	58
2.47 Channel Phase Shift Distribution at 1 Hz (20 Center Hole Channels)	59
2.48 Seismometer Phase Shift Distribution at 1 Hz	62
2.49 Seismometer Phase Shift vs. Natural Frequency (Forcing frequency equal to 1 Hz)	63
2.50 Microbarograph Data Recording Format	67
2.51 Time Word Format	68
2.52 Incremental Recorder Interface Unit Functional Block Diagram	69
2.53 Incremental Recorder Interface and Power Supply Equipment	72
2.54 Mark Products Model L-3A Seismometer	72
3.1 Distribution of Total Number of Events by Day	79
3.2 Distribution of Total Number of Events per Day	81
3.3 Distribution of the Number of False Alarms by Day	82
3.4 Distribution of the Number of False Alarms per Day	83
4.1 Reported Percentage of LP Sensors Out-of-Tolerance	86
4.2 Reported Percentage of SP Sensors Out-of-Tolerance	86

LIST OF TABLES

	PAGE
I LASAPS Tape Programs Involved in WAPS Tape Control	6
II Events Which Triggered the Large Event Detector	38
III Seismic Amplitude (M_b) for an Event Resulting in 85 nm, 0-to-peak, Ground Motion at LASA	43
IV 1 Hz Phase of Input and RA-5 Amplifier Units	61
V Microbarograph Tape Data Recording Sequence	66
VI PDP-7 to Incremental Recorder Interface Signals	70
VII Incremental Recorder Interface to Recorder Signals	71
VIII USGS High Explosive Shooting Schedule	74
IX Classification of Detected Events	78
X Magnitude of Located Events	80
XI Array Equipment Failures	87
XII Data Center Equipment Incidence of Repair	89
XIII System/360 Model 44 Computer Utilization	92
XIV PDP-7 Computer Utilization during August, September, and October 1968	93
XV LASA Very Low Rate Table	94
XVI Recorded Magnetic Tape Utilization	96
XVII LASA Tape and Film Shipments	96

GLOSSARY

AFTAC	Air Force Technical Applications Center
CPU	Central Processing Unit
CTH	Central Terminal Housing
DAMPS	Data Acquisition Multiprogramming System
ESD	Electronic Systems Division
FSS	Frame Sync Start
IISPS	Interim Integrated Signal Processing System
LAMA	Large Aperture Microbarograph Array
LASA	Large Aperture Seismic Array
LASAPS	LASA Processing Subsystem
LDC	LASA Data Center
LMC	LASA Maintenance Center
MINS	Monitoring Input System
PLINS	Phone Line Input System
SAAC	Seismic Array Analysis Center
SEM	Subarray Electronics Module
WAPS	Washington Processing Subsystem
WHV	Well Head Vault

SECTION I
INTRODUCTION

The work reported herein was performed under the "Large Aperture Seismic Array" Contract Number F19628-68-C-0401. The purpose of this contract is to:

- a. Complete and operate the Montana segment of the Interim Integrated Signal Processing System (IISPS).
- b. Participate in the development of new techniques for detection, location and identification of seismic events.
- c. Reconfigure the LASA, as required, for improved performance.
- d. Perform various experiments of interest associated with the LASA equipment and/or signal processing.
- e. Operate and maintain the LASA 24 hours per day, seven days per week.

The previous report under this contract (reference 1) described the Montana LASA participation in the IISPS. This effort, still in the testing phase, was continued this quarter. Programming was the principal work and is reported in Section II.

Attenuated seismic signals were made available from short-period (array) and long-period (subarray C2) seismometers to increase the range of earth motion measured by the LASA. Also, the Large Aperture Microbarograph Array (LAMA) was completed. A description of this array work is found in Section III.

The experiment involving utilization of the LASA for early warning of the occurrence of potentially destructive earthquakes was completed. It is concluded that the reaction time for reporting large event parameters is on the order of one-half hour and that currently employed LASA data analysis techniques are adequate for this purpose. A concluding report on the effect which oil well drilling noise has on the LASA data analysis effort, which utilizes the analog sum signal, reveals that such noise is of concern only if the well is being drilled within about two miles of the subarray center hole. These experiments are reported in Section II together with other miscellaneous projects.

The continuing effort to produce a daily Seismo Bulletin has brought forth statistics which are reported in Section III while the maintenance and operation effort are discussed in Sections IV and V, respectively.

SECTION II

DEVELOPMENT AND IMPROVEMENT OF LASA

The priority and concentration of work effort this quarter favored the IISPS as it did last quarter. However, the work was limited to programming and system testing as described in paragraph 2.1 since no further engineering work was necessary. Long and short-period attenuated seismic signal channels were incorporated so as to extend the dynamic range of the LASA and final work on the Large Aperture Microbarograph Array included installation of wind-noise reducing pipe arrays. This array work is described in paragraph 2.2. Other activity reported includes completion of the large event alert experiment (2.3.1), results from analyzing the effect which oil well drilling activity has on the LASA analysis of data (2.3.2), statistics regarding the phase response of LASA short-period seismic channels (2.3.3), and implementation of a special microbarograph data recording system (2.3.4).

2.1 IISPS

The principal work on the Montana LASA segment of the Interim Integrated Signal Processing System (IISPS) this quarter was associated with the LASA Processing Subsystem (LASAPS). The function of IISPS was presented in reference 1 and the facility still exists as described there. No engineering work was required this quarter and the system is not yet operational.

2.1.1 LASAPS

Coding and integration of the programs for the LASA Processing Subsystem (LASAPS) as specified in reference 4 were completed this quarter. However, continued program development and testing will result in refinements and modifications to these programs. The major effort this quarter was Testing (2.1.1.1), but significant programming effort was associated with the WAPS Control of LASAPS High Rate Tapes (2.1.1.2) and the LASAPS Backup System (2.1.2).

2.1.1.1 Testing

The installation of the communication circuit to the Seismic Array Analysis Center (SAAC) was completed on 5 August 1968. The first acceptance test was to transmit 618 bytes of test pattern data to SAAC at a 10 Hz rate under control of the IBM 360 Model 44 Programming System (44PS) Supervisor. That and subsequent tests through 9 August were unsuccessful due to communication circuit problems resulting in an inability to achieve synchronization. The first successful test data transmission to SAAC under 44PS Supervisor control was on 9 August. Testing under 44PS Supervisor control was continued through 12 August to

check out the interface at Billings and SAAC. On 13 August test data was successfully transmitted to SAAC under control of the IBM Data Acquisition Multi-Programming System (DAMPS) Supervisor, which is utilized by LASAPS (see paragraph 2.1.3, reference 1). The final acceptance test of the communication circuit was completed on 14 August. The test consisted of transmitting test data to SAAC under DAMPS Supervisor control in the format specified in reference 4.

Subsequent testing established the operating characteristics of the communication circuit, tested LASAPS ability to record and transmit array data, and tested LASAPS ability to operate over extended periods of time. Some initial LASAPS subsystem tests were performed. However, formal LASAPS subsystem testing is scheduled during November 1968.

2.1.1.2 WAPS Control of LASAPS High Rate Tapes

Washington Processing Subsystem (WAPS) control of the LASAPS high rate tapes was implemented to minimize manual intervention during high rate recording. The initial LASAPS system required that all high rate tapes be saved six days before being released for reuse. Under WAPS control a LASAPS high rate tape is saved only if WAPS does not get a satisfactory recording for the same time period, thus minimizing tape handling and management.

WAPS control consists of communication between LASAPS and WAPS pertaining to the status of the LASAPS high rate tapes. Upon completion of a LASAPS high rate recording, the tape is rewound and the start-stop time and serial number are sent by program control to WAPS. WAPS responds instructing LASAPS to save or recycle the tape. The response appears on the LASAPS 1052 printer informing the operator as to the status of the tape. The LASAPS subsystem tape control programs will unload the tape if it is to be saved or ready it for reuse through recycling. Thus, under normal operating conditions the only manual intervention is to replace tapes which are unloaded to be saved. If a tape is required before WAPS has responded, the tape with the earliest stop time is unloaded and the LASAPS operator and WAPS are informed that the tape is to be saved. When this condition occurs, no additional response is required from WAPS, other than the normal save or recycle message.

The logical flow of LASAPS high rate tape control is shown in Figure 2.1. For LASAPS high rate tape control with respect to LASAPS data flow see Figure 2.14, reference 1. The LASAPS high rate tape programs which are involved in WAPS control appear in Table I. The program designation scheme is described in paragraph 2.1.3.1 of reference 1.

High Rate Data
Block Write Completion

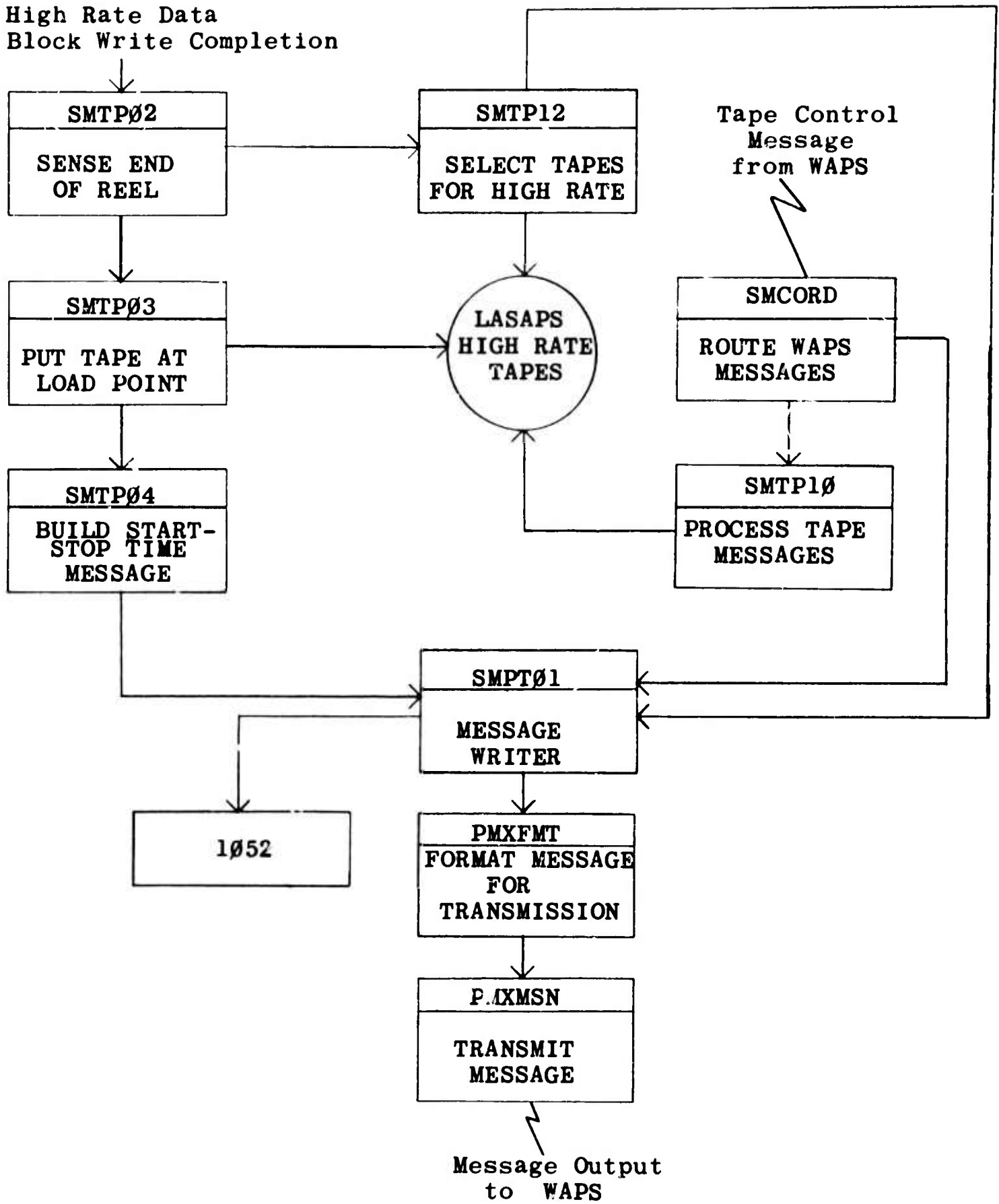

Figure 2.1 LASAPS High rate tape control.

TABLE I

LASAPS TAPE PROGRAMS INVOLVED IN WAPS TAPE CONTROL

- | | | |
|--------|---|-------------------------------------------------------------------------------------------------------------------------------------------------------------------|
| SMTP02 | - | Receives control upon completion of a high rate data block write, senses end-of-reel upon completion of a high rate tape, and initiates trailer label processing. |
| SMTP03 | - | Completes the trailer label processing initiated by SMTP02 and puts the tape at load point. |
| SMTP04 | - | Receives control upon completion of trailer label processing, assigns the tape to WAPS, and sends WAPS the tape serial number and start-stop time. |
| SMTP10 | - | Processes tape control messages received from WAPS and unloads or recycles tapes as instructed by WAPS. |
| SMTP12 | - | Selects tapes for high rate recording and de-selects tapes assigned to WAPS if none are ready. Informs the LASAPS operator and WAPS of any de-selections. |

2.1.2

LASAPS Backup System

The function of the LASAPS Backup System is to record high rate data with the PDP-7 computer during periods when the LASAPS equipment is unavailable for on-line operation. The requirements for the LASAPS Backup System are specified in reference 4. For a detailed description on the backup system high rate tape format see Appendix A.

The backup system program was written and checked out this quarter. It is in conformity with the original LASA high rate tape except in the subarray and seismometer status fields which are maintained by the backup system as a function of high rate recording. Upon initial backup system loading, the subarray and seismometer status are read in by punched cards which reflect the LASAPS status prior to becoming unavailable. Status changes in real time are determined by punched cards and teleprinter input. The status which can be specified for a single subarray is (1) all short-period data invalid, (2) all long-period data invalid, (3) all data invalid, or (4) none of the preceding conditions. The status which can be specified for a single seismometer is (1) instrument out of order or (2) instrument operating correctly. The subarray and seismometer status are reflected in a trailer field which is appended to the first record of each high rate tape and to any record covering a period in which a status change occurred.

2.2

Array

2.2.1

Attenuated Short-Period Seismic Signal Channel

An attenuated short-period seismic signal channel has been added to all subarrays except E3 to reduce the effects of equipment saturation during large earth motion events and to extend the magnitude range for seismic signal analysis. This attenuated signal is not derived at E3 because there are no SEM channels to carry the signal. It is derived at D2 from sensor 26 and at all other subarrays from sensor 10. The inconsistency at D2 is caused by the presence of the short-period triaxial seismometer installed at sensor 10. This is not to say that the signals from the triaxial vertical component are not consistent with those from the HS-10-1/A seismometers installed elsewhere in the LASA, but the signal handling equipment for the three components has physically filled the WHV and, thus, there is no longer any room to install another RA-5 amplifier for an attenuated signal. In all cases the attenuated signal appears on SEM channel 22.

The attenuated signal differs by 30 dB from the unattenuated one. The standard LASA short-period channel exhibits saturation for ground motion in excess of 700 nm at 1 Hz, whereas the attenuated channel will saturate above a nominal 22,100 nm signal at 1 Hz. The maximum range of the seismometer is approximately 12.5 mm.

To implement this attenuated signal, new type Dual-Channel WHV panels were utilized as shown in Figure 2.2. They were prepared from standard panels (Figure 2.3) obtained during the retrofitting operation at B1, F3, and E3 when improved panels were installed. These new panels provide dual signal outputs as shown in Figure 2.4. A resistive network provides the nominal 30 dB attenuation.

The ratio of the two output signals is not expected to remain at the 30 dB value established during installation because of system gain variations. Inasmuch as two separate RA-5 amplifiers are utilized and since practically all gain variations arise within the amplifiers (due to temperature instability), it is necessary to utilize the amplifier telemetry calibration facility incorporated in this panel in order to determine precisely the ratio. The calibration signals for this purpose are the standard LASA 1 Hz sine wave and pseudo-random sequence generated signals.

Redesign of the seismometer data coil termination network was necessary to maintain damping to the 60% to 80% of critical limits. The loading effect of the attenuator was thus taken into account and virtually no compromise of the low common-mode noise voltage was evident because of the impedance increase at the input to the unattenuated signal amplifier.

Radio frequency filtering at the input, output, and power terminals of each amplifier was necessary to reduce interaction between the pump frequencies of the RA-5 parametric amplifiers. Similar filters were previously installed with the tri-axial seismometer for which there are three such amplifiers operating.

A capability for quickly disconnecting the amplifiers from the panel was added for the field repair activity and to reduce the number of panels required for spares. Instead of removing the entire WHV panel whenever amplifier failures occur (the usual case in sensor repair) the amplifier alone can now be readily removed and replaced. Also, the attenuator was designed as a plug-in unit as an aid for field calibration and adjustment. This feature facilitates experimentation with different values of attenuation from the same seismometer.

2.2.2 Attenuated Long-Period Seismic Signal Channel, C2

Subarray C2 long-period seismic signal channels - LASA SEM channels 26, 27 and 28 - were modified to provide attenuated signal outputs for use during analysis of large magnitude events which previously saturated the standard long-period channels. The signal outputs from the vertical, N-S horizontal, and E-W horizontal components were attenuated 30 dB below the standard LP signal outputs. The standard LASA LP channel saturates from ground motion in excess of 40 μm at 0.04 Hz (350 mV/ μm). The attenuated

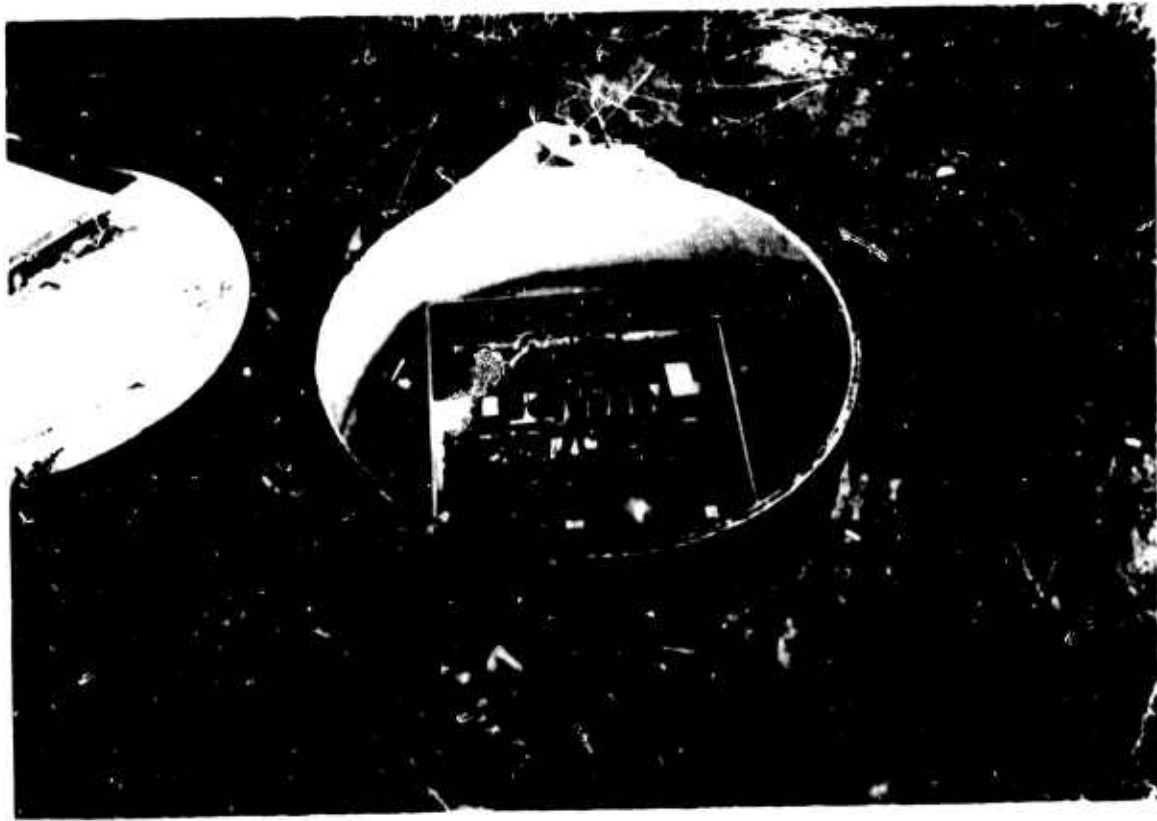

Figure 2.2 Dual-Channel WHV panel.

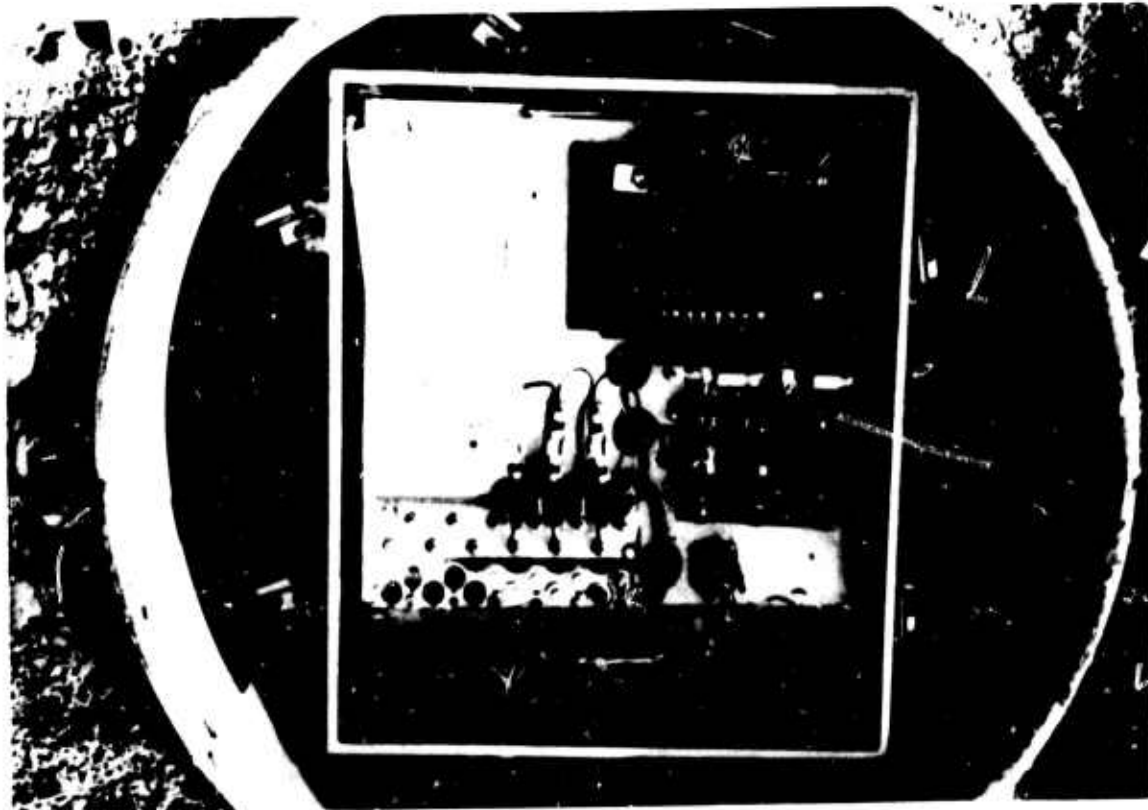

Figure 2.3 Standard LASA WHV panel.

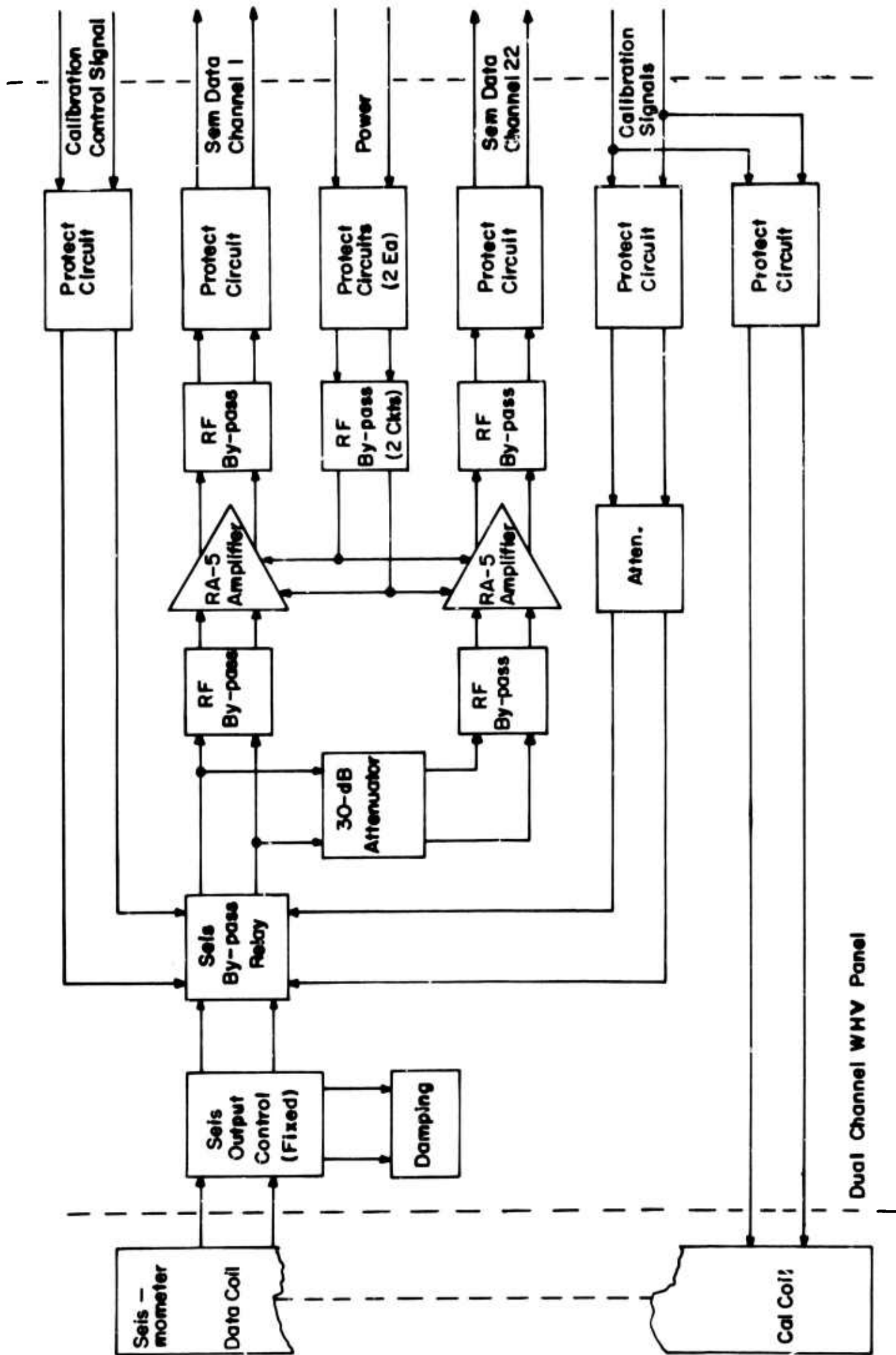

Figure 2.4 Two-Channel WHV electronics block diagram.

channels were designed to saturate for ground motion in excess of 1265 μm at 0.04 Hz (11 $\text{mV}/\mu\text{m}$).

Factors considered in the design of the attenuated channel include the following system limitations: (1) the required attenuation of 30 dB should not precede the amplifier input because the signal-to-amplifier noise ratio would be too low making the channel ineffective except for extremely large magnitude events, (2) the amplifier, Texas Instruments Type II, input circuitry limits the input signal level to 30 mVp-p , and (3) any attenuator used must present a very high impedance to the data coil to prevent affecting the seismometer damping.

The required 30 dB attenuation was obtained by adding a 14 dB attenuator at the input to the amplifier and by decreasing the amplifier gain by 16 dB, as shown in Figure 2.5. In order to accomplish the amplifier gain change, it was necessary to replace the high-gain line drivers with low-gain line drivers. The output for the required channel sensitivity of 11 $\text{mV}/\mu\text{m}$ at 0.04 Hz was determined from the following:

$$A = \frac{G_c i T^2 S}{4\pi^2 M}$$

where, A = channel output, mVp-p
 G_c = seismometer generator constant, N/A
i = calibration current, μA
T = period of the calibration current, sec.
S = channel sensitivity, $\text{mV}/\mu\text{m}$
M = seismometer moving mass, Kg

The parameter values are: $i = 5000 \mu\text{A}$; $T = 25 \text{ sec.}$; $S = 11 \text{ mV}/\mu\text{m}$; $M = 10 \text{ Kg}$. The generator constants for these three seismometers vary somewhat from the nominal value of 0.0326 N/A. The values measured at installation - 0.0314, 0.0323, and 0.0308 N/A - were used for the vertical, N-S horizontal, and E-W horizontal components, respectively.

2.2.3 Large Aperture Microbarograph Array (LAMA)

The Large Aperture Microbarograph Array (LAMA) is now complete and complements the Montana LASA. As shown in Figure 2.6, it is comprised of LTV-6 and ESSA microbarograph equipment. All equipment and pipe array installations, except the LTV-6 microbarograph equipment, were made this quarter. The Environmental Science Services Administration (ESSA) microbarograph equipment and wind-noise attenuators have been installed at 13 subarrays - A0, B1, B2, B3, B4, C1, C2, C3, C4, D1, D2, D3, and D4 - and wind-noise attenuators were added to the LTV-6 microbarographs at 8 subarrays - A0, E1, E2, E4, F1, F2, F3, and F4. Figure 2.7 is a map of the LAMA sensor locations. Each microbarograph sensor consists of a wind-noise attenuator (pipe

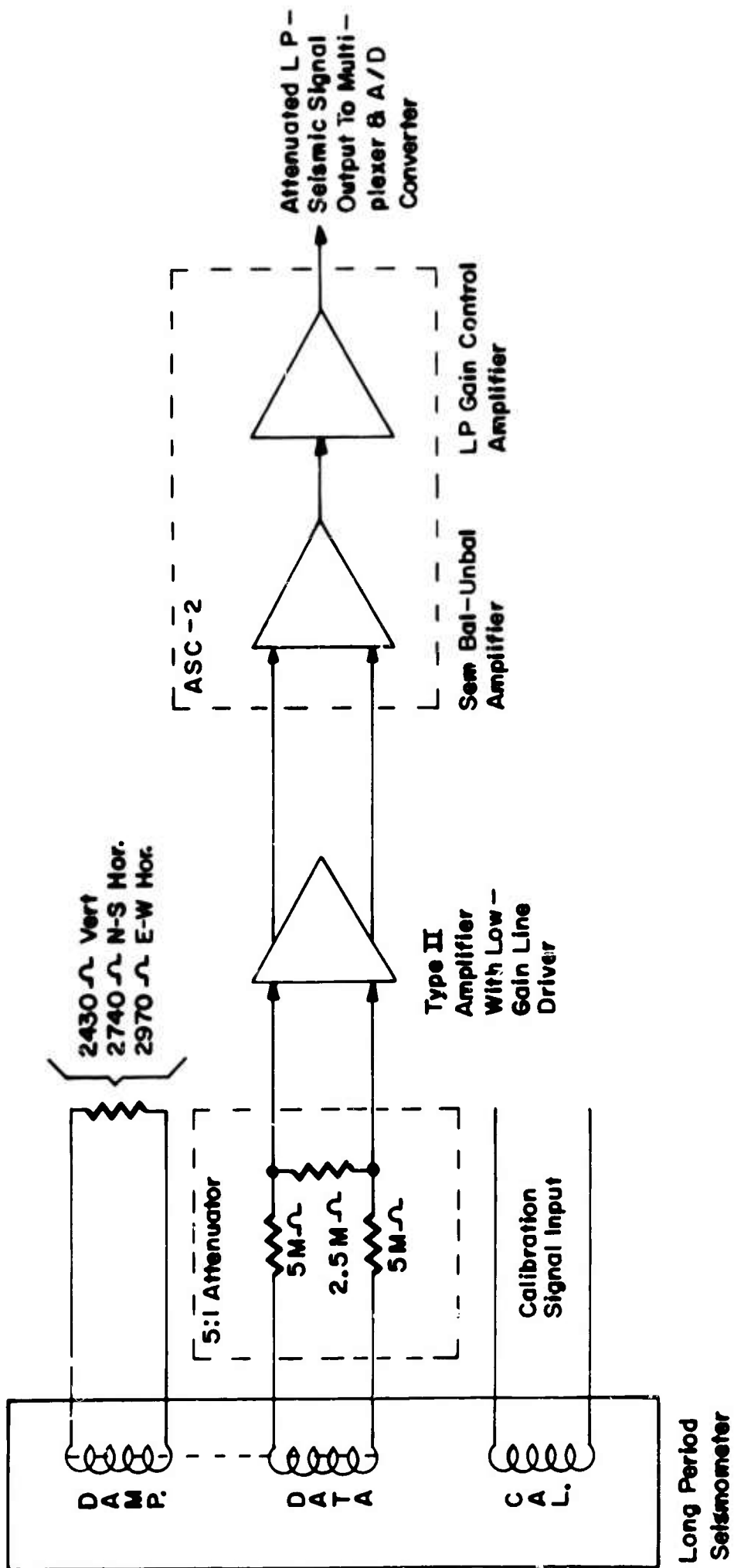

Figure 2.5 Attenuated long period seismic signal channel diagram.

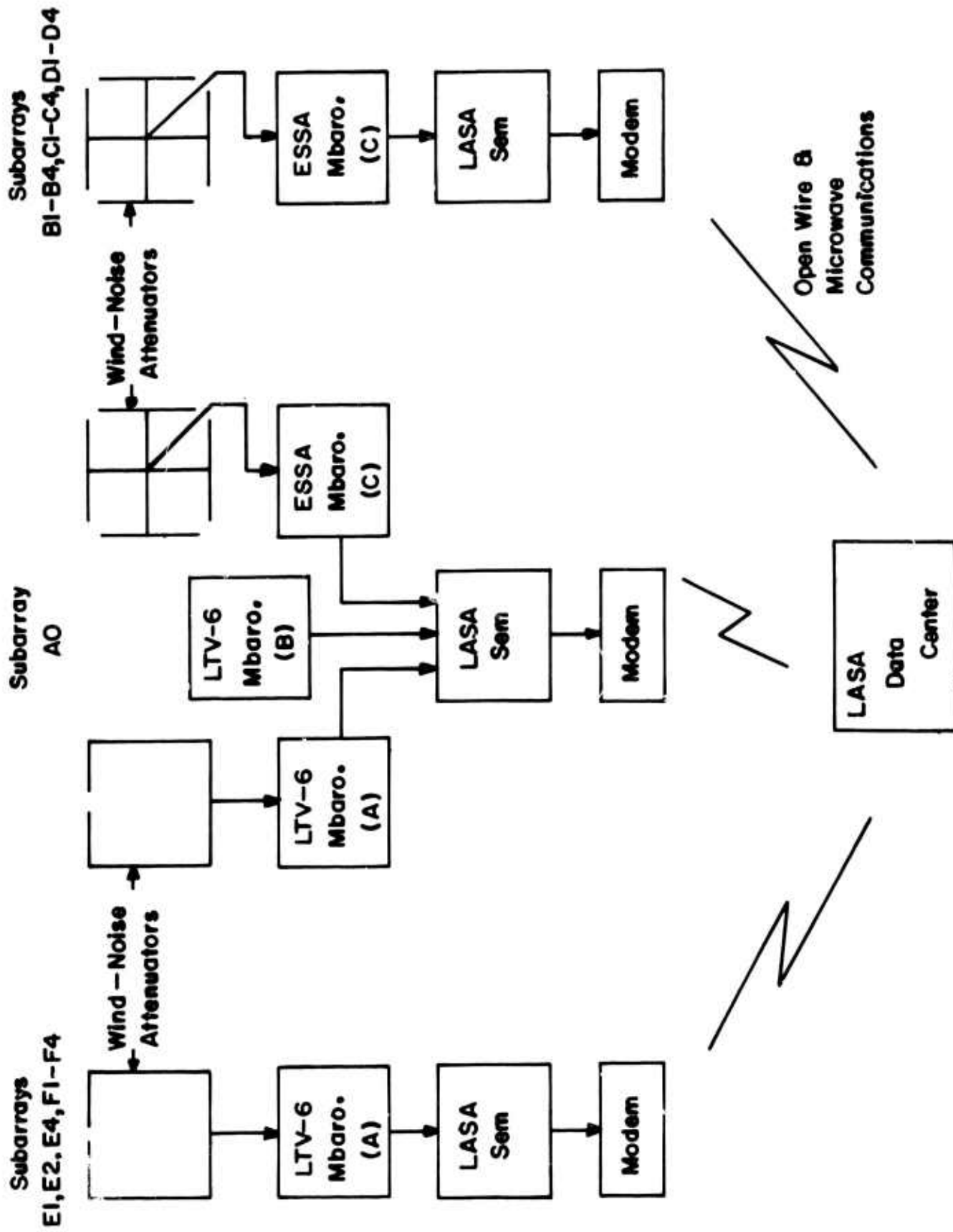

Figure 2.6 Large Aperture Microbarograph Array.

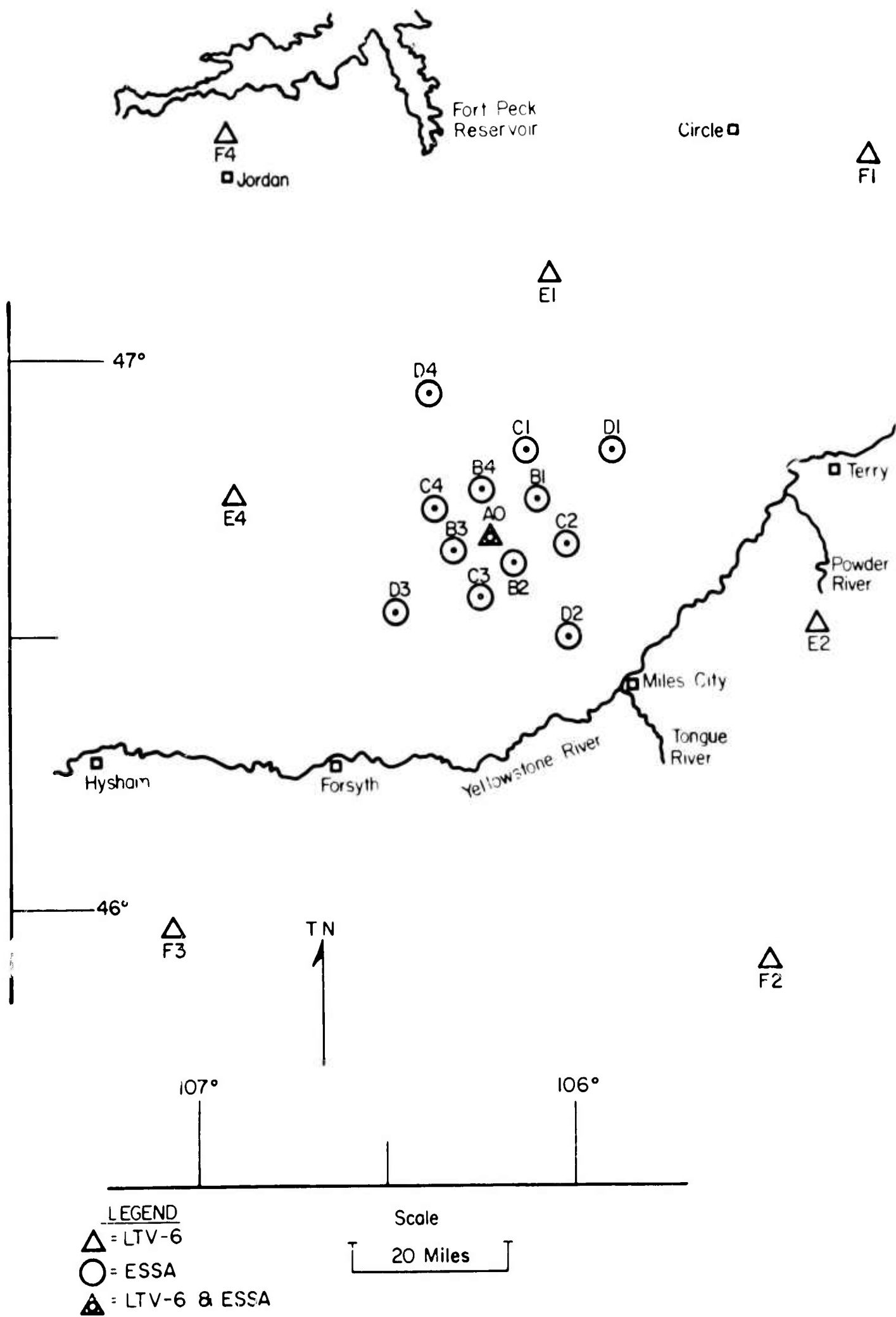

Figure 2.7 LAMA geometry and sensor locations.

array) and a microbarograph assembly which interfaces with the LASA SEM to insert this data into the LASA data stream.

The LTV-6 microbarograph equipment installation (Figures 2.8 and 2.9) was previously reported (reference 3). A simplified block diagram of the equipment preceding the SEM Digital Equipment is shown in Figure 2.10. The wind-noise attenuator reduces the pressure disturbances caused by local wind activity and supplies the microbarometric pressure fluctuations (signals) to the LTV-6 acoustical network and transducer. The transducer operates on a capacitor microphone principle whereby the deflected diaphragm results in a capacitance bridge circuit unbalance. The unbalanced bridge signal is demodulated and amplified to provide a balanced signal output to the LASA SEM. The SEM terminates the balanced output signal in 10,000 ohms, converts the balanced signal to an unbalanced signal, and provides a presampling low-pass filter for the reduction of signal aliasing.

Calibration of the LTV-6 microbarograph consists of adjusting the gain to the proper value. It is set by utilizing the acoustical step calibrator shown in Figures 2.11 and 2.12. This calibrator consists of a reference volume and syringe contained within an insulated box. A known volume change, introduced into the acoustical system by the syringe, produces a pressure change which results in an output from the microbarograph system. The amount of pressure change is computed to a first approximation from $\Delta p = - \frac{P_0 \Delta v}{V_0}$, where Δp is the pressure

change in millibars, P_0 is the atmospheric pressure in millibars, Δv is the volume change in cm^3 , and V_0 is the total volume in cm^3 . The calibrator is considered to operate isothermally and small second-order effects are ignored. The atmospheric pressure, P_0 , is measured before each calibration by an accurate CENCO barometer. The total volume, V_0 , is the volume of the calibrator and the input volume of the LTV-6. The gain is adjusted to the desired system sensitivity.

The LTV-6 microbarographs, which operate into SEM channel 14, were adjusted for a sensitivity of $46.7 \text{ mV}/\mu\text{bar}$. This sensitivity provides a full-scale system range of $250 \mu\text{bars}$ p-p. The frequency response is determined by the acoustical network (low end) and the presampling filter (high end) and is designated Microbarograph System Frequency Response A (Figure 2.13). The code used in reporting this system response is A250, where A designates the frequency response and 250 the peak-to-peak range in μbars .

It was necessary to install a different presampling low-pass filter, for the reduction of signal aliasing, due to the recording rate used for microbarograph data recording (see paragraph 2.3.4). The presampling filter for the standard SEM channel has a high-frequency cutoff of 5 Hz. SEM channel 14 was

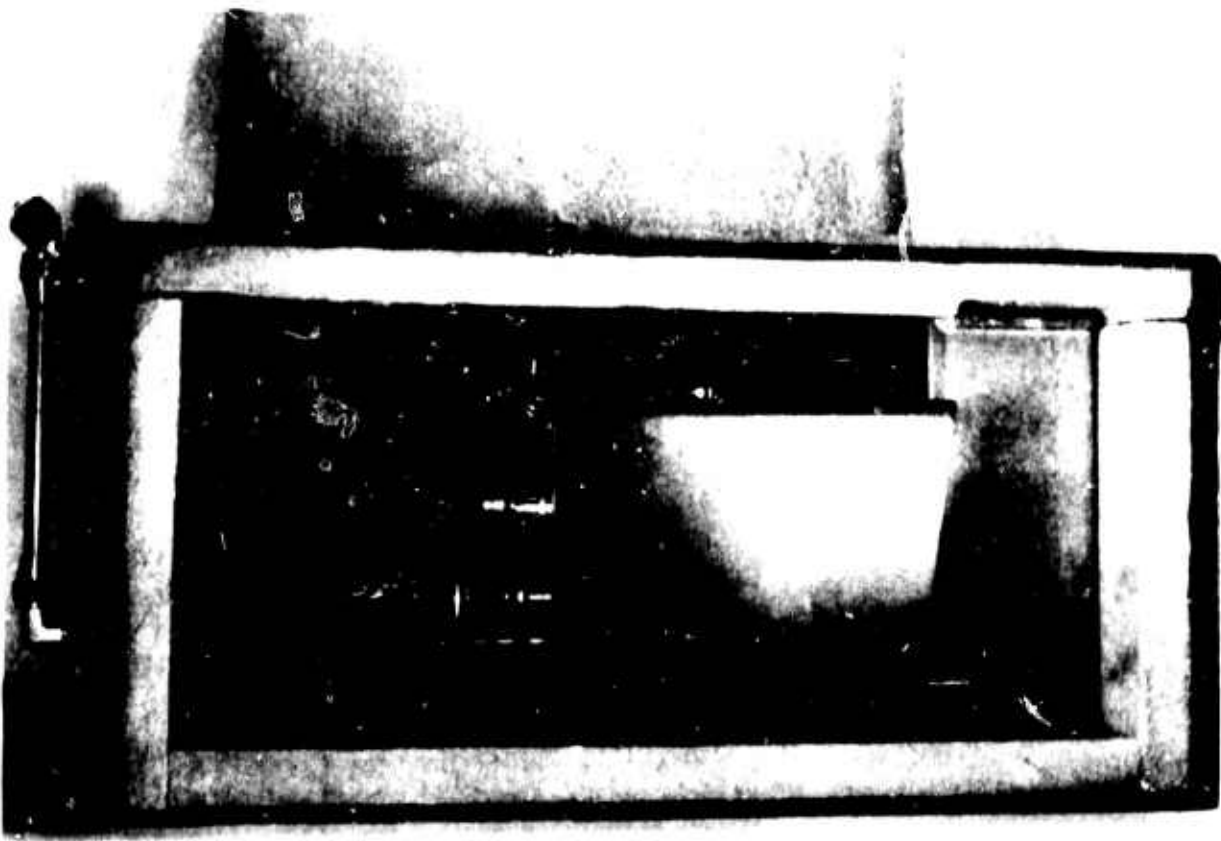

Figure 2.8 LTV-6 components in insulated box.



Figure 2.9 LTV-6 CTH installation.

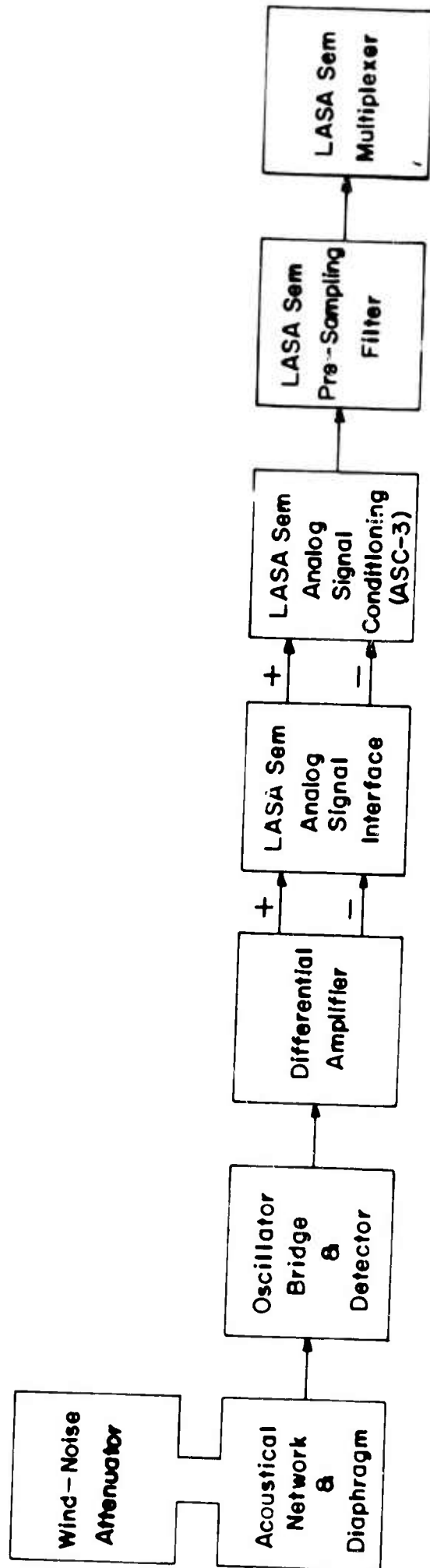

Figure 2.10 LTV-6 equipment block diagram.

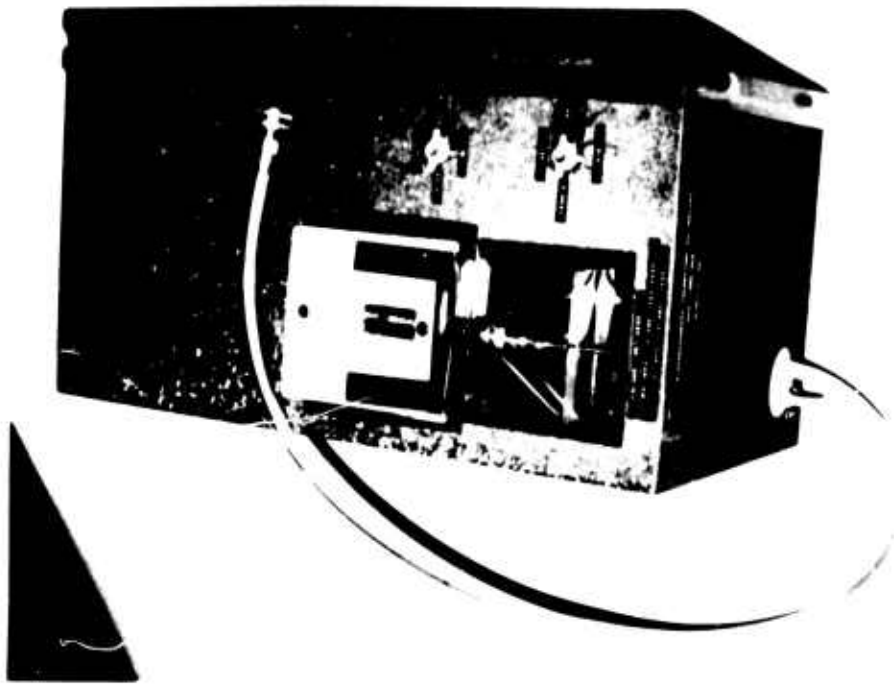

Figure 2.11 Acoustic step calibrator.

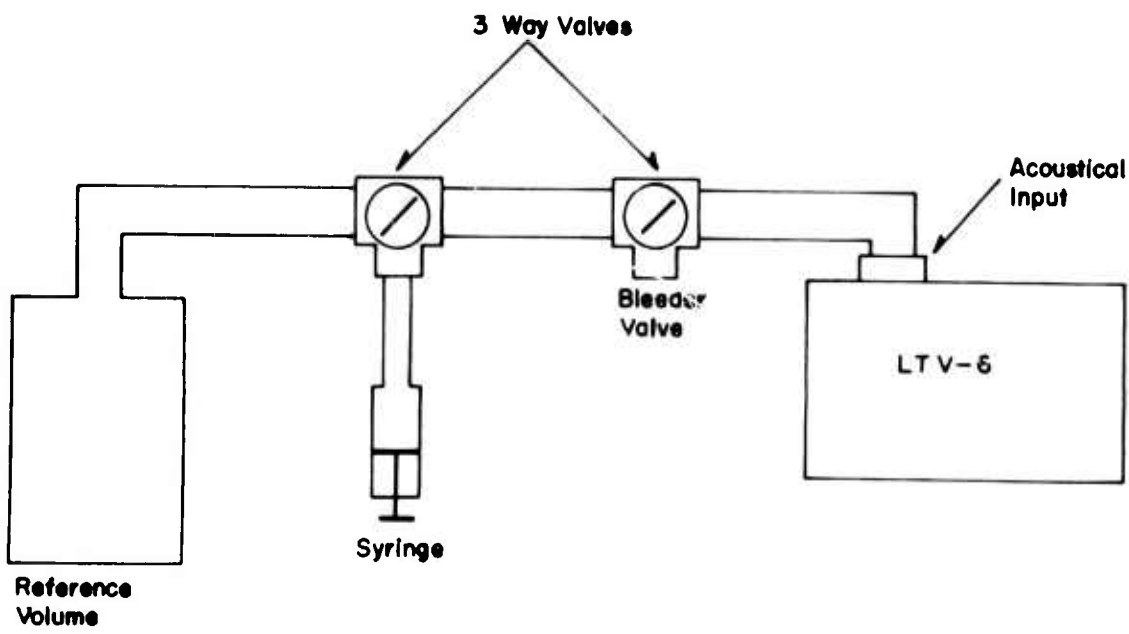

Figure 2.12 Acoustic step calibrator diagram.

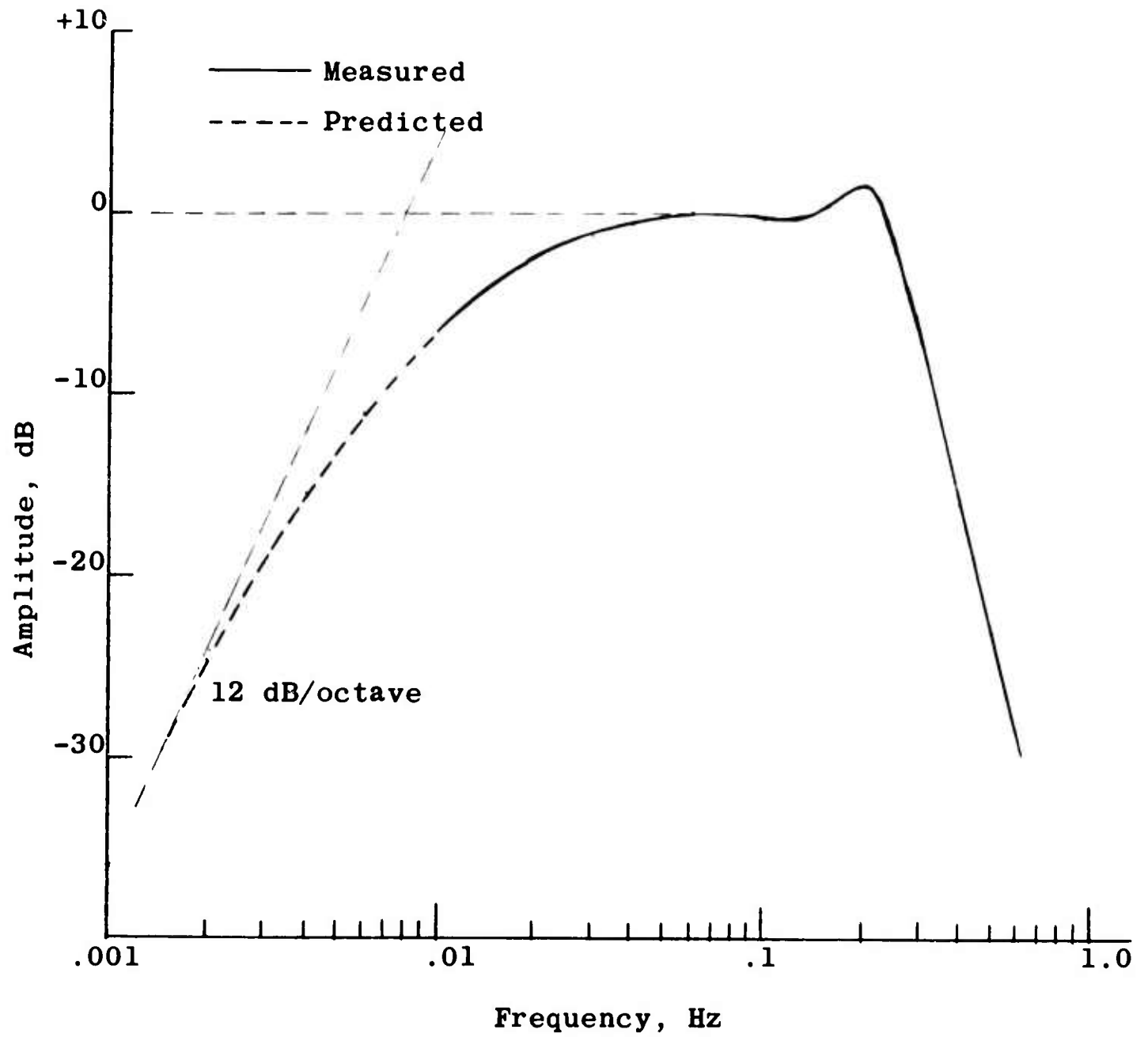

Figure 2.13 Microbarograph Frequency Response A

modified (Figure 2.14) to utilize an available 3-pole Chebyshev filter which provides a response essentially flat from dc to 0.2 Hz.

Wind-noise attenuators similar to the Daniels linear pipe (reference 2), also referred to as line microphones, were installed at the eight subarrays containing LTV-6 microbarographs. These pipe arrays are designed to improve the acoustic signal-to-noise ratio by attenuating wind generated interfering signals. (The evaluation of this device is discussed in an engineering report soon to be issued.) The pipe array is designed for installation within the subarray fenced-in central area which is approximately 150 feet square. It is composed of 580 feet of galvanized pipe and numerous fittings. The dimensions are shown in Figure 2.15. All eight subarrays have the same length of pipe installed; however, the dimensions of one subarray central area, F3, differs substantially from the others. The array is constructed of two 290-ft. asymmetrical line microphones joined together with a tee (Figure 2.16). Each 290-ft. section contains 130 feet of 2-inch, 50 feet of 1½-inch, 40 feet of 1¼-inch, 30 feet of 1-inch, 20 feet of ¾-inch, and 20 feet of ½-inch pipe. The tee junction is connected to the CTH acoustical inlet (Figure 2.17) by buried semi-rigid plastic tubing. The array is folded by the use of pipe elbows and is installed within the subarray central area fence (Figure 2.18). The pipe passes through an eight-inch culvert at the gate opening to permit vehicle travel within the central area. The acoustical orifices are made from 1/8-inch brass pipe plugs drilled to provide an acoustical impedance of 60 ohms. The pipe is drilled and tapped every 10 feet to accept the plugs and a 1/2-inch length of Tygon tubing is placed over the plug end to prevent water drop accumulation (Figure 2.19). A total of 58 orifices are used in the pipe array. The pipe is installed on 2 x 4-inch blocks with the orifices on the underside of the pipe. The orifices at the ends of the pipe are installed in elbows.

An LTV-6 microbarograph with an extended low frequency response was installed at subarray A0. The low frequency response has been extended to 0.001 Hz. To achieve this response, the leak tube between the input volume and the reference volume was lengthened. An interior view of the LTV-6 with the 0.01-inch ID leak tube is seen in Figure 2.20. The original 0.816-inch length was increased to 12 inches. The low frequency response was measured by applying a step function pressure change and analyzing the leak rate. The resulting response, designated Microbarograph System Frequency Response B, is shown in Figure 2.21. The amplifier was also modified so the sensitivity could be adjusted to 7 mV/μbar. This sensitivity provides a full-scale system range of 1667 μbars p-p. The modified LTV-6 was connected to LASA SEM channel 7 at subarray A0. The response code (explained above) for this channel is B1667.

The ESSA microbarograph equipment was supplied by the ESSA Geoacoustics Group, Washington, D.C. A simplified block

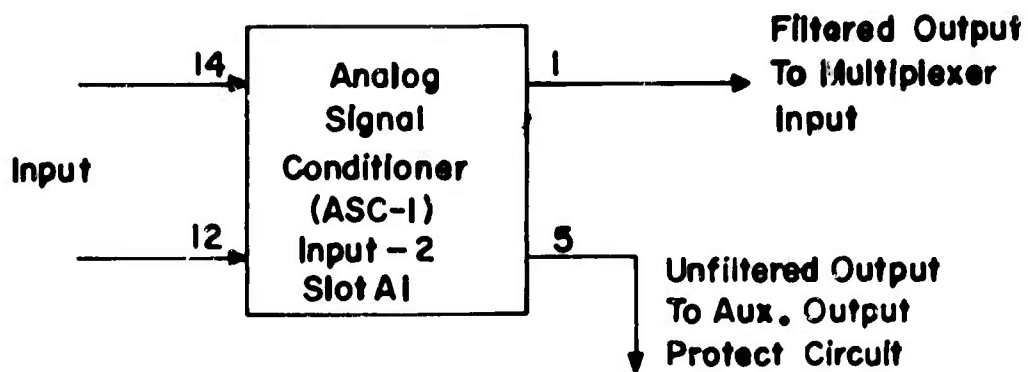

(a) Standard LASA Sem Channel 14

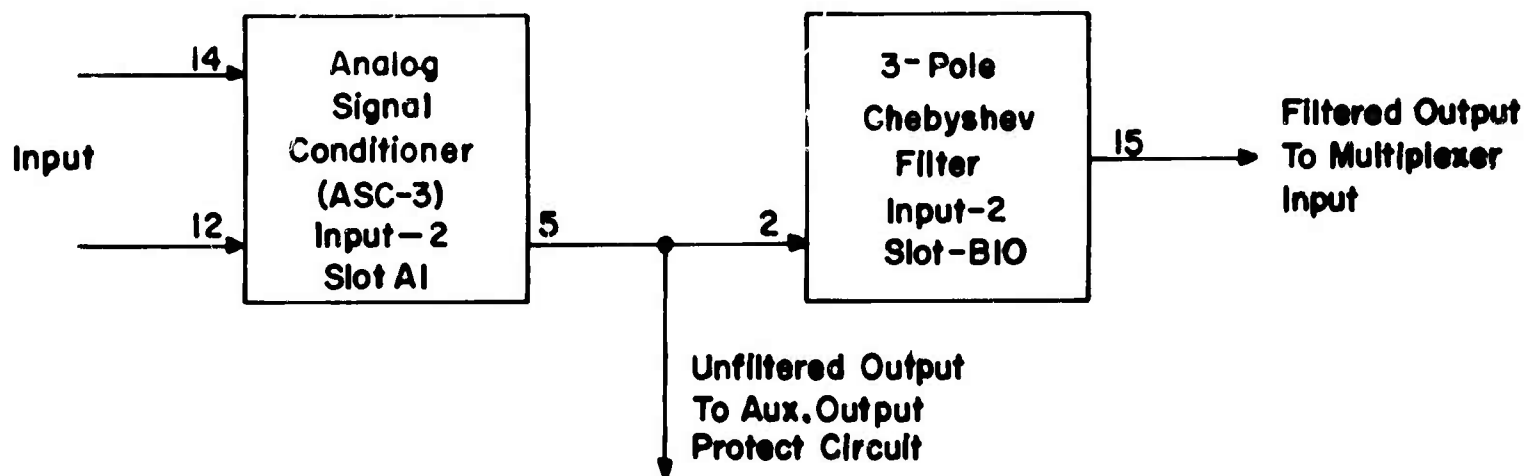

(b) Modified LASA Sem Channel 14

Figure 2.14 SEM Microbarograph channel block diagram.

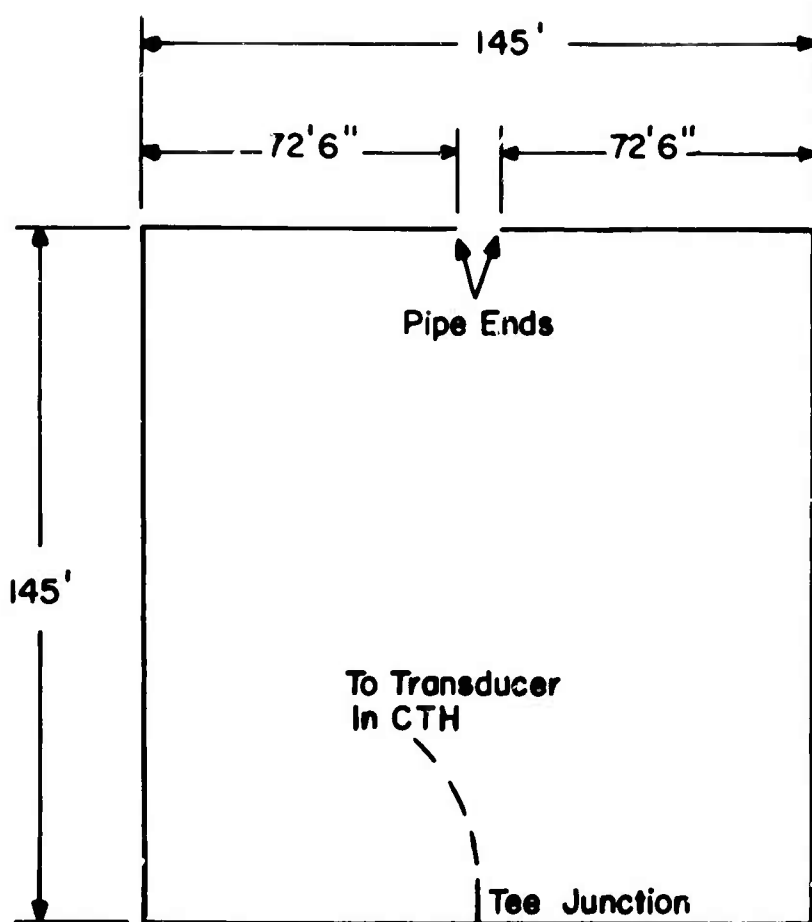

(a) Pipe array at A0, E1, E2, E4, F1, F2, F4.

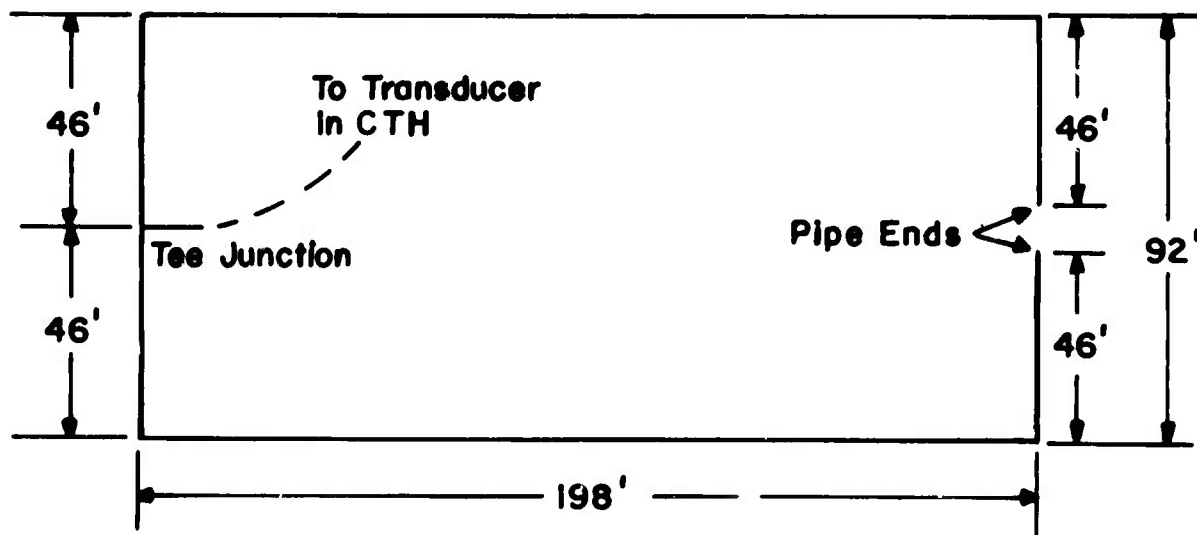

(b) Pipe array at F3.

Figure 2.15 LTV-6 pipe array dimensions.

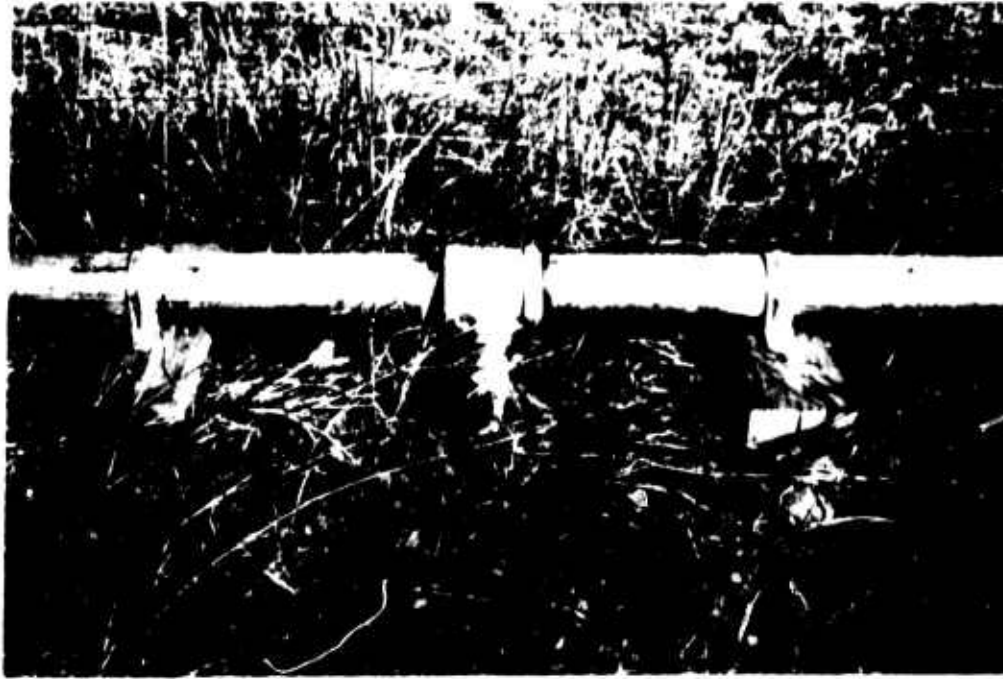

Figure 2.16 LTV-6 pipe array tee junction.



Figure 2.17 CTH acoustical inlet.



Figure 2.18 LTV-6 pipe array culvert crossing.



Figure 2.19 LTV-6 pipe array acoustical orifice.



Figure 2.20 LTV-6 with 12-inch vent tube.

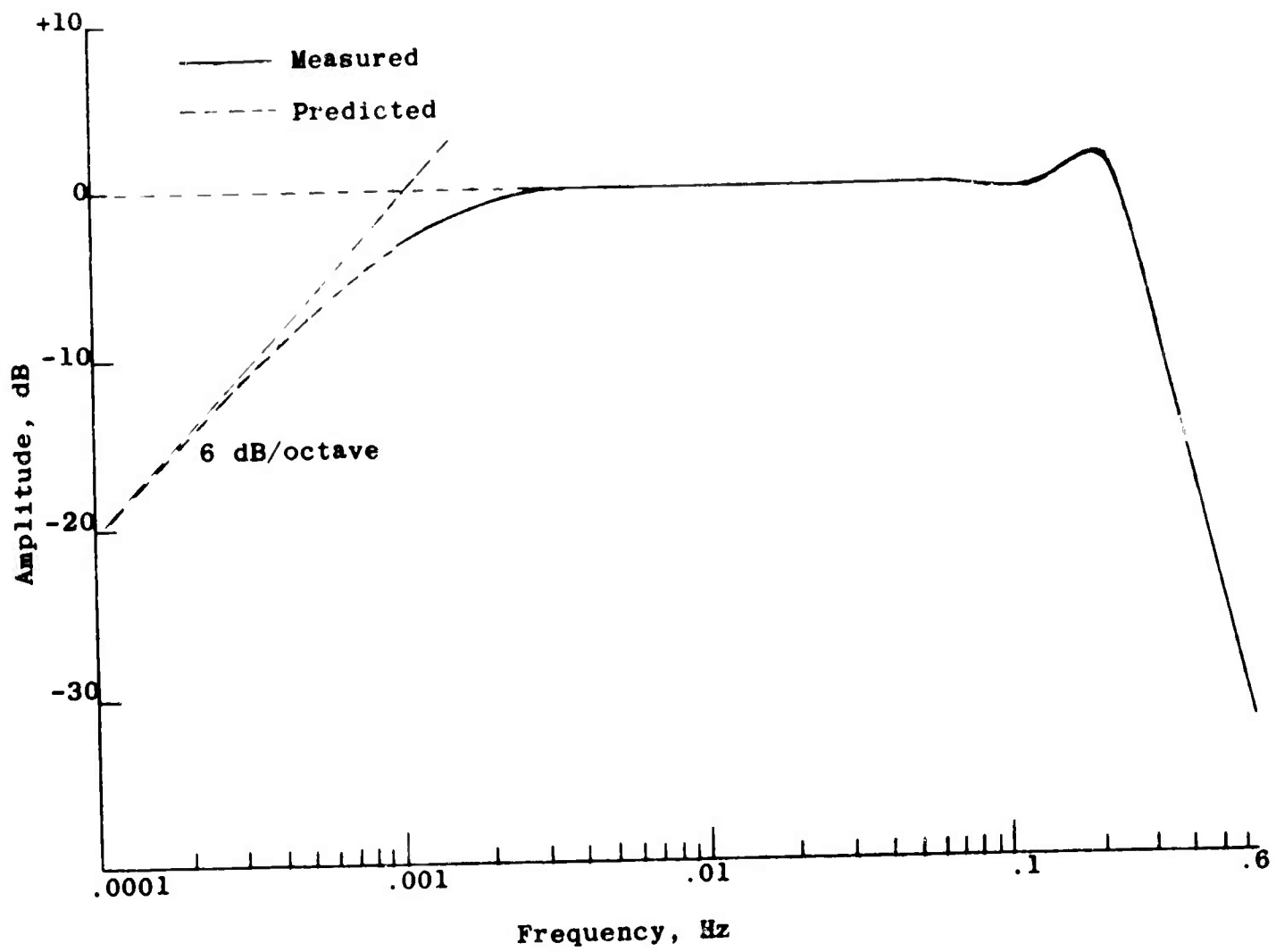

Figure 2.21 Microbarograph Frequency Response B

diagram of this microbarograph system is shown in Figure 2.22. The wind-noise attenuator operates as previously mentioned. The transducer operates on the capacitor microphone principle whereby the pressure fluctuations deflect the diaphragm which results in a capacitance change in the frequency-determining circuit of an oscillator. This produces a frequency-modulated (FM) signal whose deviation is a measure of the pressure deflecting the diaphragm. The FM signal is converted by the discriminator to a balanced dc voltage for input to the SEM. The SEM converts the balanced signal to an unbalanced signal, provides a presampling filter with a 5 Hz cutoff frequency, and eliminates any residual carrier frequency from the signal.

The ESSA microbarograph can is shown in Figure 2.23. This galvanized metal can (diameter $10\frac{1}{2}$ inches, height 28 inches) houses the back-up volume, the transducer, and the oscillator. The back-up volume, a one-gallon bottle filled with vermiculite, is mounted with insulation completely surrounding it. The transducer is mounted on a tube attached to the back-up volume and is connected by Tygon tubing to the acoustic input of the can. The oscillator is mounted on top of the transducer as shown in Figure 2.24. The power and signal cable connects from the oscillator to the power supply. It runs through a weatherproof feed-through in the can and is buried a few inches into the ground between the can and the CTH auxiliary input (Figure 2.17). The transducer can is buried at the center of the subarray central area (Figure 2.25) and is covered by a galvanized metal cone painted white for protection of the can from the sun and rain. The discriminator is mounted on the combination power supply and distribution circuit chassis (Figure 2.26) and installed within the CTH.

Calibration of the ESSA microbarograph consists of determining the sensitivity of the system. There is no gain adjustment and the sensitivity varies from system to system depending upon the characteristic differences in the acoustic networks, diaphragms, and discriminators. The frequency response is fixed by the acoustical network and the discriminator and is designated Microbarograph System Frequency Response C (Figure 2.27). The sensitivity is determined by using the portable calibrator (Figure 2.28) provided by ESSA. This calibrator consists of a dc motor driven bellows to produce a sinusoidal pressure signal. The calibrator is connected between the calibration reference volume (the insulated volume around the one-gallon back-up volume bottle) and the transducer as shown in Figure 2.29. The bellows calibrator produces a nominal $9 \mu\text{bar}$ p-p acoustic signal at sea level with an accuracy of approximately $\pm 5\%$. A correction is applied for the altitude of the microbarograph location. The sensitivity is computed from the voltage output (p-p) caused by the pressure change. The ESSA microbarographs, which operate into SEM channel 18, have a nominal full-scale range of $125 \mu\text{bars}$ p-p. The response code for these channels is C125.

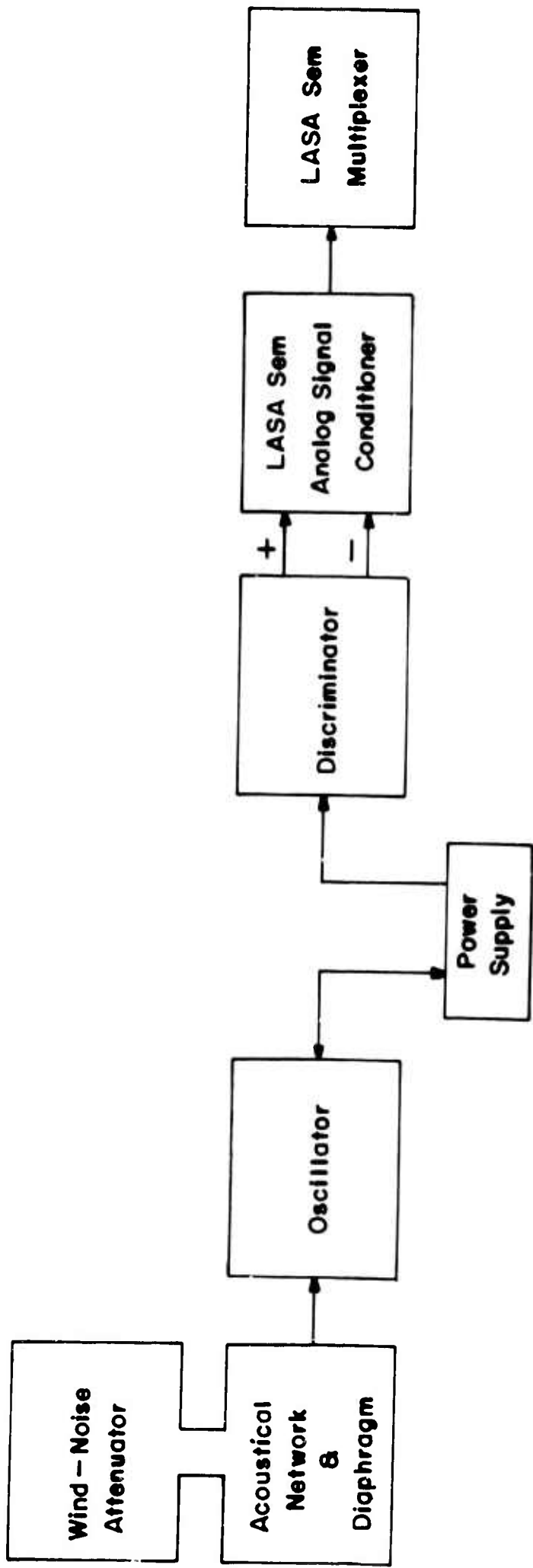

Figure 2.22 ESSA equipment block diagram.

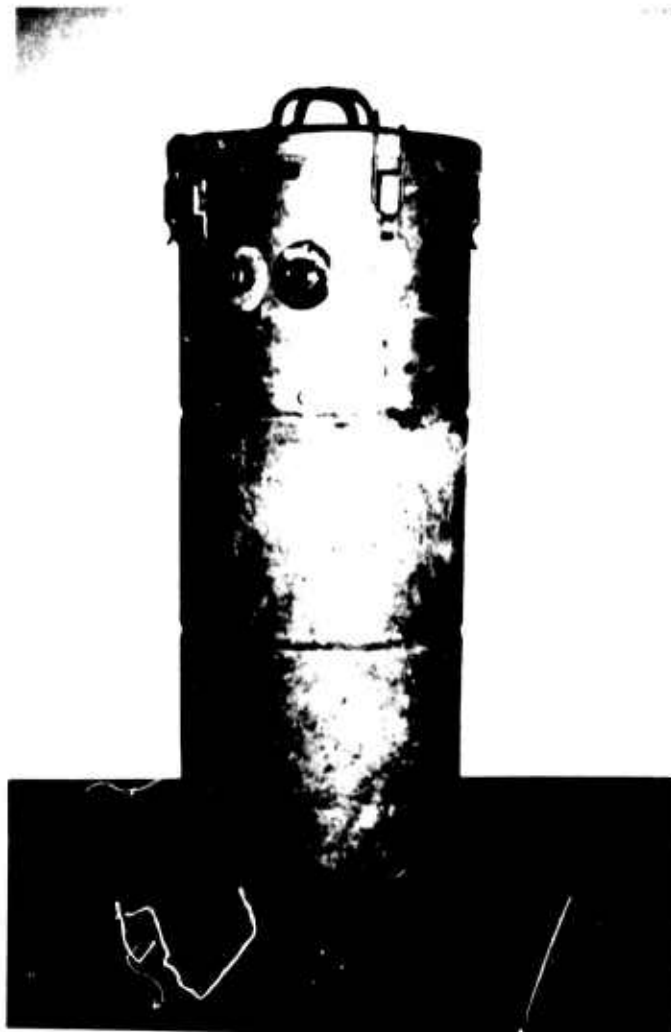

Figure 2.23 ESSA transducer can.

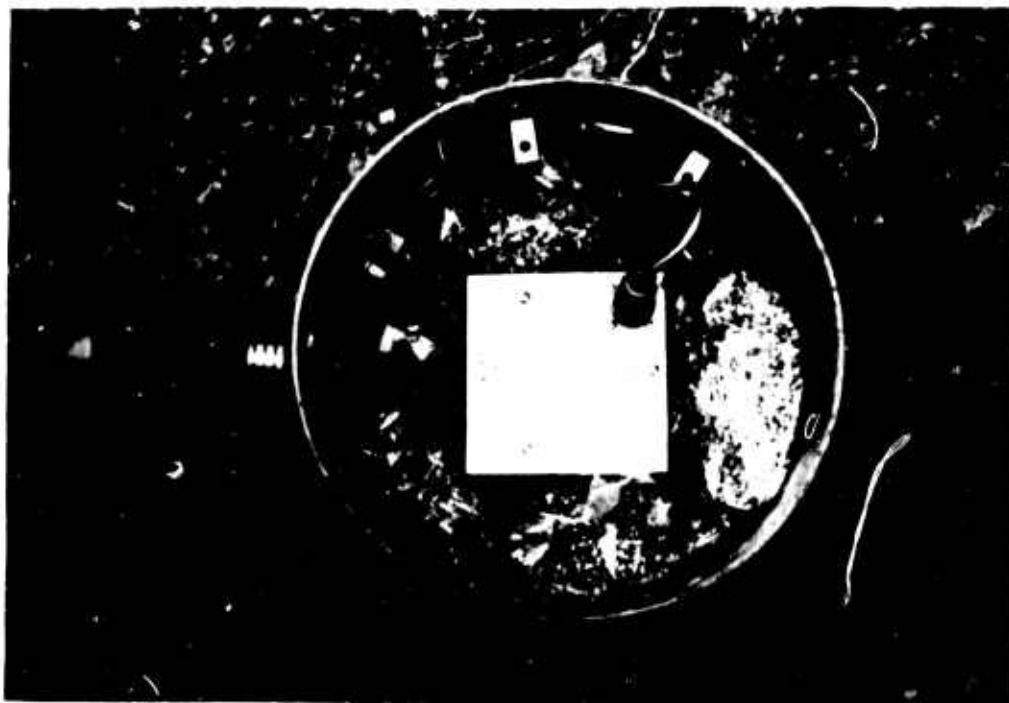

Figure 2.24 ESSA oscillator mounted in can.



Figure 2.25 ESSA transducer can installation.



Figure 2.26 ESSA power supply and discriminator installation.

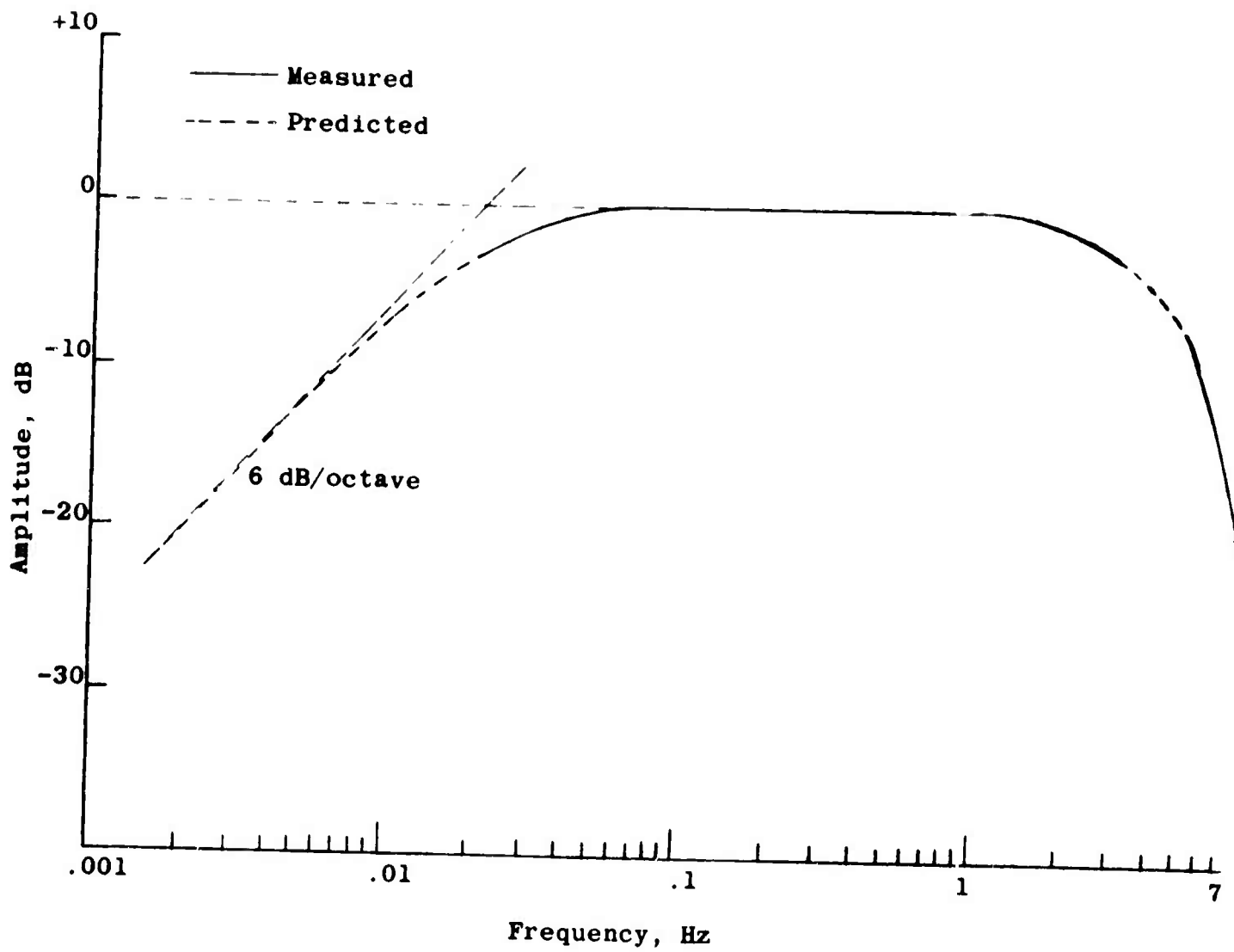

Figure 2.27 Microbarograph Frequency Response C



Figure 2.28 ESSA portable calibrator.

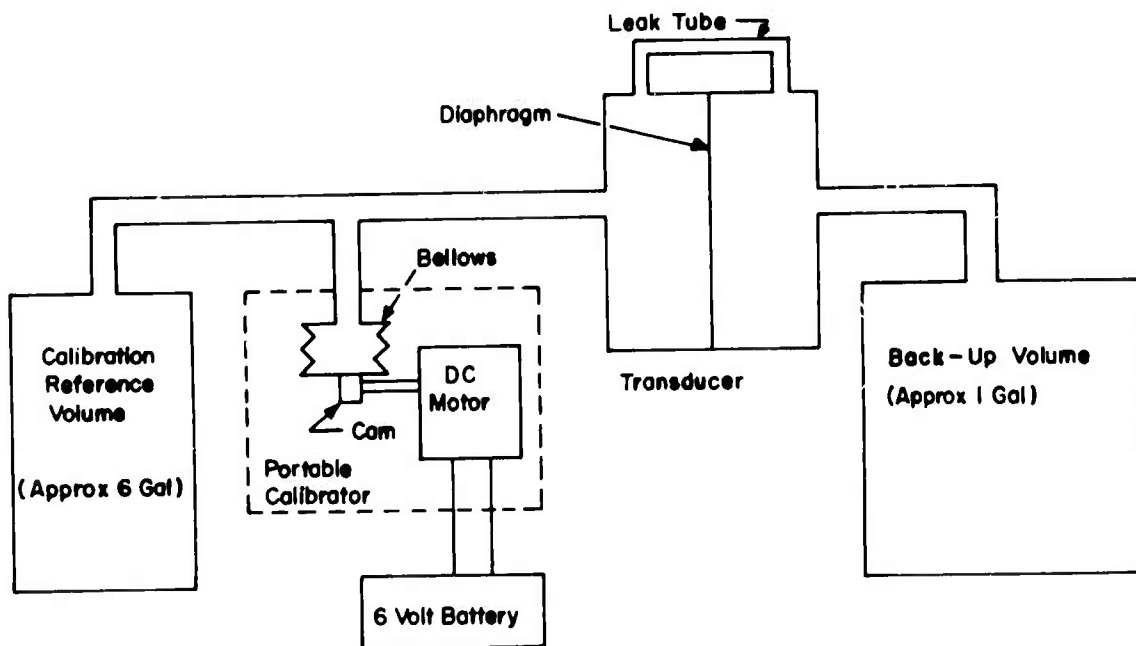

Figure 2.29 ESSA calibration system diagram.

Wind-noise attenuators (pipe arrays), designed by the ESSA Geoacoustics Group, were assembled at the thirteen subarrays previously indicated. Although different in design from the wind attenuators connected to the LTV-6 microbarographs, they also were designed to improve the acoustic signal-to-noise ratio by attenuating wind-generated interfering signals. The pipe array is designed for installation within the subarray fenced-in central area and is essentially non-directional at the infrasonic wave-lengths of interest. The dimensions of the pipe array, composed of 860 feet of galvanized pipe and numerous fittings, are shown in Figure 2.30. The array is configured with four symmetrical "T" sections connected to a cross junction (Figure 2.31) which is connected by a section of garden hose to the transducer can nearby. The array is constructed from 5-ft. pipe sections joined together with tee fittings. The "T" sections, constructed using the tee fitting shown in Figure 2.32, contain 40 feet of 1-inch and 35 feet of 3/4-inch pipe in each center arm and 25 feet of 1/2-inch, 15 feet of 3/8-inch, and 30 feet of 1/4-inch pipe in each half "T" section. The pipe passes through 8-inch culverts (Figure 2.33) where vehicle travel is necessary. The acoustical orifices (Figure 2.34) are made from 1/8-inch brass nipple-type pipe plugs drilled to provide a matching acoustical impedance. The plugs are installed in the tee fittings every five feet in the pipe array for a total of 173 orifices. Each orifice is protected by a 6-inch shaped length of Tygon tubing slipped over the plug.

2.3 Miscellaneous Effort

2.3.1 Large Event Alert Experiment Operation

The large event alert experiment (paragraph 2.3.1 of reference 1) has been concluded. The following discussion (2.3.1.1) and conclusions (2.3.1.2) are based on statistics gathered since the experiment began on 11 June 1968.

2.3.1.1 Discussion

As previously reported, the large event threshold was placed in service on 11 June 1968. This threshold, 62 nm of earth motion, was slightly less than the 100 nm expected for a fully operational system. Thirty-eight events (Figure 2.35 and Table II) exceeded this threshold between 11 June 1968 and 23 August 1968, at which time the threshold was raised to 85 nm.

Reporting of large events was to be made only for those events detected during the LASA Analysts' normal working hours which overlapped with Eastern Daylight Time working hours. Three such events occurred during the experiment. They are:

1. Event 27. Arrival time 14 12 50.4 GMT on 2 August 1968 from Oaxaca, Mexico. This event saturated the normal LASA system. A report was

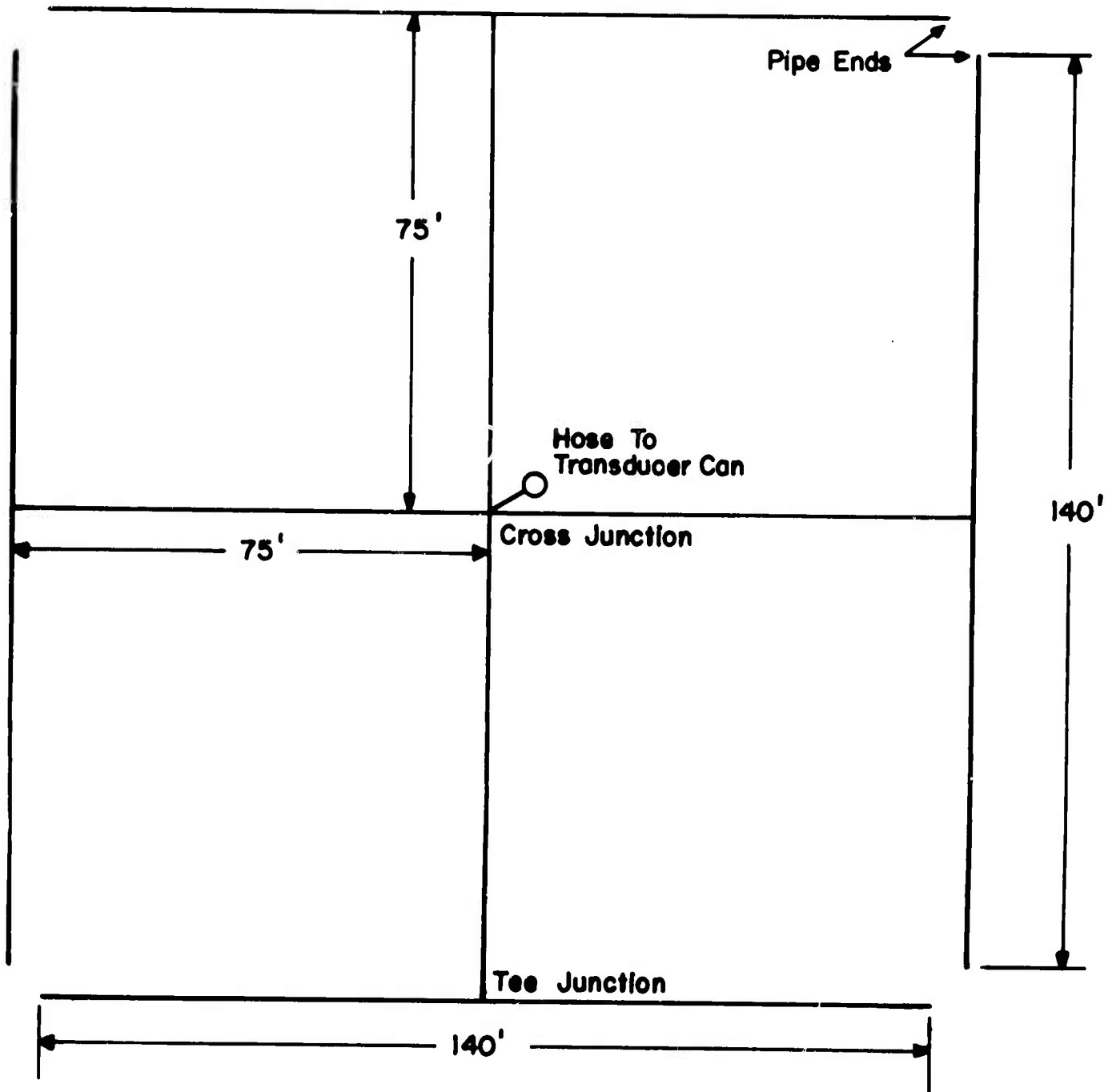

Figure 2.30 ESSA pipe array dimensions.

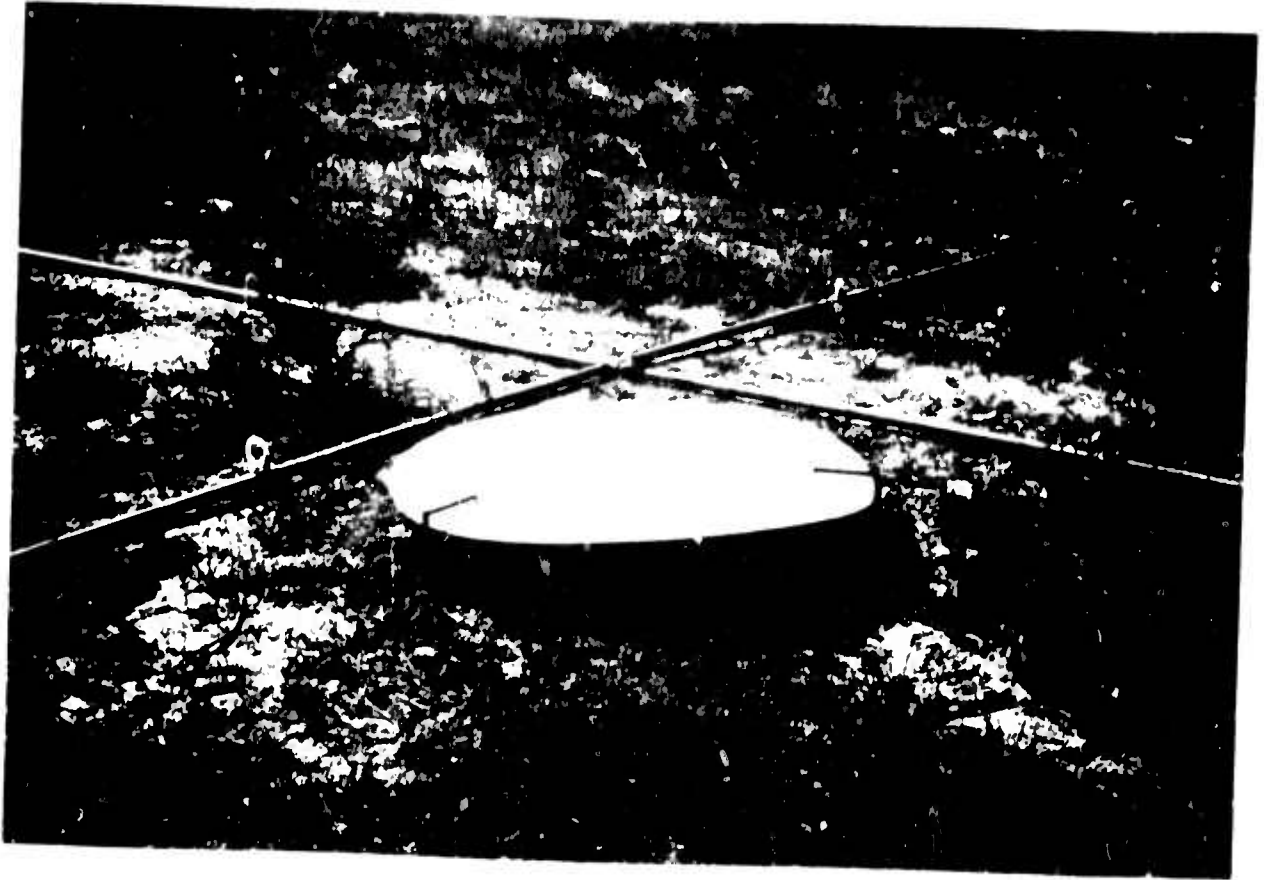

Figure 2.31 ESSA array cross junction.



Figure 2.32 ESSA array tee junction.



Figure 2.33 ESSA array culvert crossing.



Figure 2.34 ESSA array acoustical orifice.

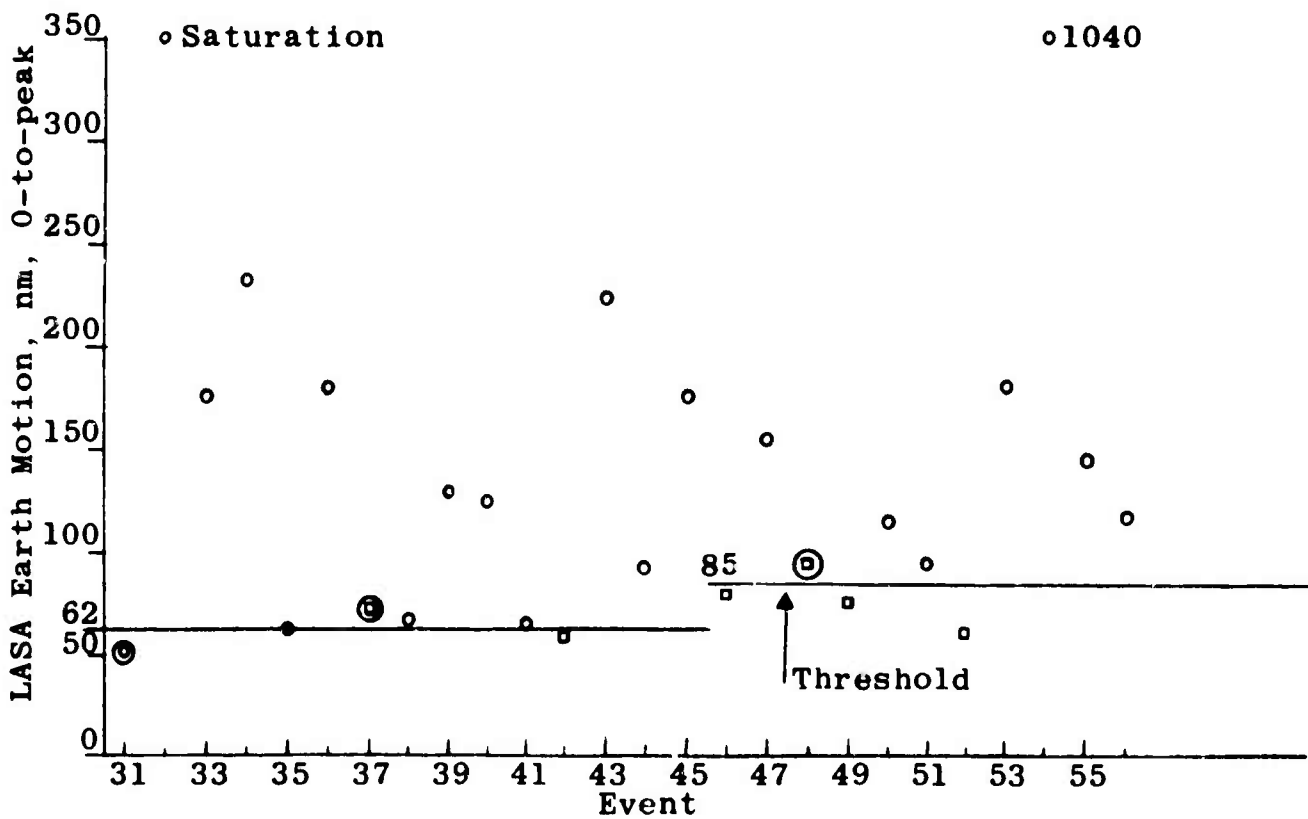
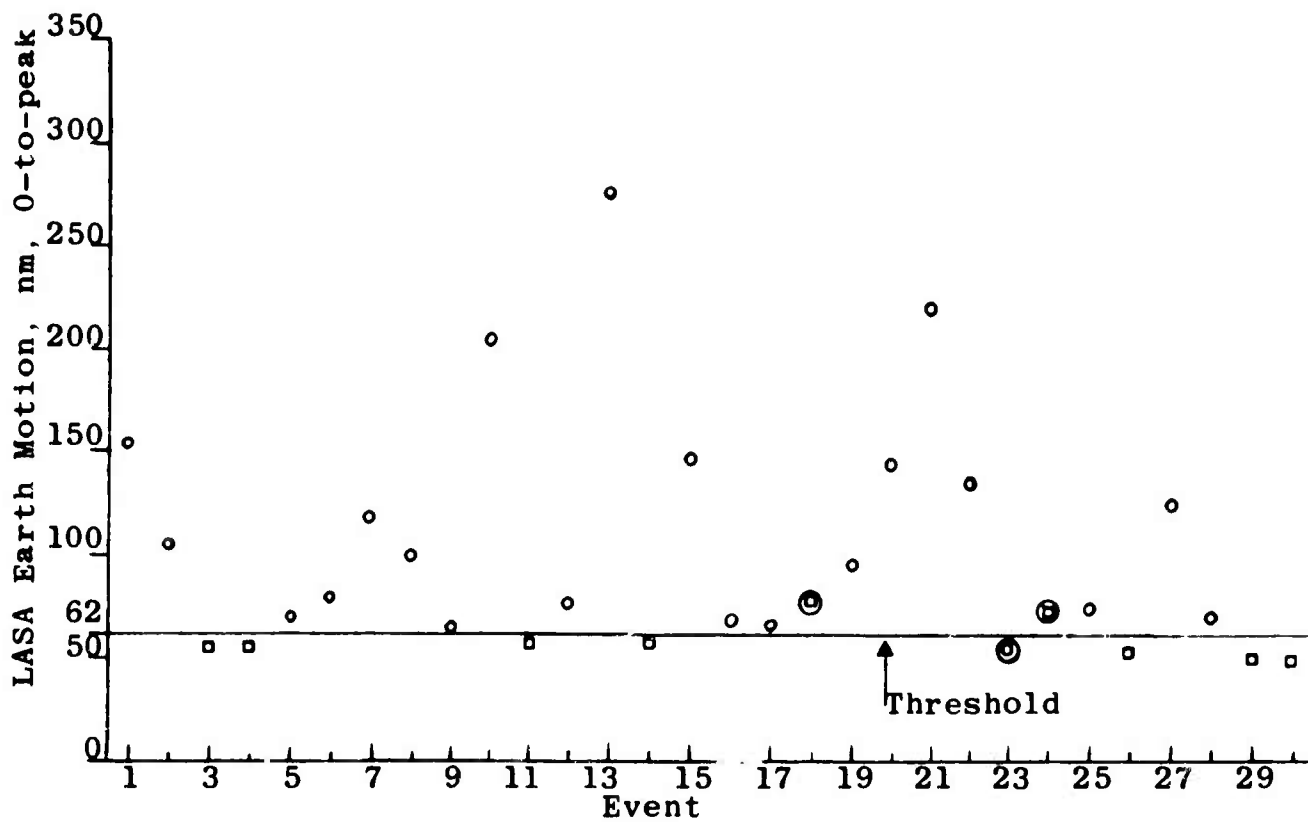

- Event exceeded threshold.
- ◻ Event did not exceed threshold.
- ⊙ Average amplitude of array exceeded threshold but less than 4 of the E and F ring detectors did.
- ⊗ Average amplitude of array did not exceed threshold but more than 4 of the E and F ring detectors did.

Figure 2.35 Plot of events causing LASA earth motion near and in excess of the large event threshold.

TABLE II
EVENTS WHICH TRIGGERED THE LARGE EVENT DETECTOR

EVENT	DATE 1968	EVENT ARRIVAL TIME - GMT	EPICENTER	AMPLITUDE & MAGNITUDE		REMARKS		
				LASA			USC&GS	
				nm	Mb		Mb	Ms
1	11 June	05 59 07.9	El Salvador	152	5.4	5.3	-	Slight tsunami reported. Felt.
2	12 June	13 53 21.5	Off East Coast of Honshu, Japan	105	5.7	6.0	7.0	
3	12 June	22 09 13.8	Off East Coast of Honshu, Japan	70	5.6	5.7	5.3	
4	13 June	21 22 07.5	Off East Coast of Honshu, Japan	75	5.7	5.5	5.2	
5	14 June	12 27 58.8	Kuril Islands	113	5.9	5.5	-	
6	15 June	05 17 54.1	Near Coast of Chiapas, Mexico	100	5.6	5.4	5.2	
7	15 June	06 11 58.4	East China Sea	64	5.6	5.7	-	
8	17 June	12 04 23.0	Hokkaido, Japan	78	5.8	5.7	6.1	
9	19 June	08 23 19.6	Northern Peru	276	6.3	6.4	6.9	
10	20 June	02 48 23.5	Northern Peru	144	5.8	5.8	5.7	
11	21 June	00 35 55.6	Northern Peru	67	5.5	5.6	-	
12	26 June	01 45 38.6	Near Coast of Northern California	-	-	5.5	5.4	
13	26 June	10 35 09.1	Hokkaido, Japan	66	5.5	5.5	4.9	
14	1 July	04 14 22.4	W. Kazakh S.S.R.	95	6.0	5.5	-	
15	1 July	16 57 02.2	Honshu, Japan	142	6.0	5.9	-	
16	2 July	03 50 40.7	Near Coast of Guerro, Mexico	101	5.8	5.3	-	
17	5 July	11 39 48.8	Honshu, Japan	220	6.2	5.9	6.3	
18	12 July	00 56 07.6	Off East Coast of Honshu, Japan	133	5.8	6.0	5.8	

TABLE II (Continued)

EVENT	DATE 1968	EVENT ARRIVAL TIME - GMT	EPICENTER	AMPLITUDE & MAGNITUDE			REMARKS	
				LASA		USC&GS		
				nm	Mb	Ms		
19	12 July	04 07 58.8	Off East Coast of Honshu, Japan	51	5.5	5.5	5.5	
20	17 July	06 30 48.3	Costa Rica	73	5.4	5.1	-	
21	25 July	07 36 48.3	South of Tonga	51	5.5	6.4	-	Felt on Ravul.
22	25 July	07 41 21.0	PP of Tonga Event	-	-	-	-	
23	25 July	11 01 25.5	Kuril Islands	125	5.9	5.9	5.5	
24	26 July	14 10 03.1	Peru	71	5.8	5.2	-	
25	30 July	20 48 26.9	Near Coast of Northern Peru	52	5.4	5.8	6.4	Felt in Northern Peru.
26	1 Aug.	20 37 05.0	PP of event at 20 33 25.8 Luzon	-	-	5.9	7.3	296 killed, extensive property damage.
27	2 Aug.	14 12 50.4	Philippine Islands Oaxaca, Mexico	SAT	-	6.3	7.1	4 killed, many injured, extensive property damage.
28	3 Aug.	05 07 42.6	Ryukyu Islands	173	6.0	6.4	6.7	
29	5 Aug.	16 29 31.3	Shikoku, Japan	232	6.1	6.3	6.1	14 injured.
30	7 Aug.	08 11 21.3	Hokkaido, Japan	63	5.5	5.6	-	
31	10 Aug.	02 25 39.2	Molucca Passage	181	PKP	6.3	7.6	135 aftershocks from area reported by LASA between this event and N. Celebes event of August 14.
32	11 Aug.	02 52 38.7	Near Coast of Peru	69	5.4	5.6	-	
33	11 Aug.	12 45 33.0	Andreanof Islands	129	5.6	5.5	-	

TABLE II (Continued)

EVENT	DATE 1968	EVENT ARRIVAL TIME - GMT	EPICENTER	AMPLITUDE & MAGNITUDE			REMARKS
				LASA		USC&GS	
				nm	M _b	M _b M _s	
34	14 Aug.	22 33 05.6	Northern Celebes	125	PKP	6.0 7.4	Tsunami swept coastal area of Donggal District, 200 killed at Tamabu, Tuguan Island submerged, approx. 500 occupying this island were lost.
35	16 Aug.	18 32 00.0	Central Mexico	64	5.3	5.4 -	
36	18 Aug.	18 51 16.8	Solomon Islands	222	6.2	6.2 -	
37	22 Aug.	14 09 00.3	Near Islands	91	5.5	5.4 6.0	
38	23 Aug.	22 47 53.4	Salta Province, Argentina	171	6.0	5.8 -	
39	3 Sep.	08 32 28.1	Black Sea (Turkey)	153	5.8	5.7 6.6	25 killed, 200 injured, considerable damage in Bartin Area.
40	9 Sep.	00 45 21.6	Northern Peru	117	6.0	5.3 -	
41	9 Sep.	00 47 45.4	Northern Peru	95	5.9	6.0 -	
42	12 Sep.	22 56 22.5	Fiji Islands Reg.	180	6.5	5.9 -	
43	20 Sep.	06 08 52.6	Northern Venezuela	1040	6.8	6.2 -	2 killed, 37 injured. Damage in state of Sucre, Venezuela and on Trinidad. Also felt in Northern Gnyana, possible Tsunami north coast of Trinidad.

TABLE II (Concluded)

EVENT	DATE 1968	EVENT ARRIVAL TIME - GMT	EPICENTER	AMPLITUDE & MAGNITUDE				REMARKS
				LASA		USC&GS		
				nm	M _b	M _b	M _s	
44	25 Sep.	10 44 53.1	Mexico - Guatemala Border Region	201	5.7	5.7	-	15 dead, 500 injured and heavy property damage in Southern Chiapas. Possible 7 foot tsunami at Salina Cruz.
45	26 Sep.	14 50 27.7	Fiji Islands Region	201	6.1	5.8	6.8	

phoned to the USC&GS, Lincoln Laboratory, and Dr. DeNoyer, USGS, within 45 minutes of event arrival.

2. Event 29. Arrival time 16 29 31.3 GMT on 5 August 1968 from Shikoku, Japan. This event registered 232 nm 0-to-peak, 6.1 M_b , and was reported by telephone to the USC&GS, Lincoln Laboratory, and Dr. DeNoyer, USGS, within 25 minutes of arrival.
3. Event 45. Arrival time 14 50 27.7 GMT on 26 September 1968 from the Fiji Islands Region. This event registered 201 nm 0-to-peak, 6.1 M_b , and was reported by telephone to the USC&GS, Lincoln Laboratory, and Dr. DeNoyer, USGS, within 25 minutes of event arrival.

As seen by the entries in Table II, other large events occurred during hours not suitable for reporting. These events were analyzed according to the established procedure but were not specially reported. The data is available early if users so desire, but it is now reported only through the Seismo Bulletin.

One criteria for reporting an event as an alert event is that it must exceed 6.0 M_b . Inspection of Table III shows that for an 85 nm earth motion the magnitude of most events reported will be less than 6.0 M_b . Thus, there will be a large false alarm rate. In fact, inspection of Table VI, reference 1, for 100 nm earth motion shows a similar situation but the possibility of missing some distant events also exists. Thus, the trade off between the number of false alarms and missed events leads to adopting the 85 nm threshold. Of course, with completely automatic processing of event data such considerations become trivial and only relevant event data would be reported. Unfortunately, with the present LASA processing scheme, the luxury of completely automatic processing is not available.

It is recognized that disastrous events are not limited to the somewhat arbitrary threshold of 6.0 M_b . In fact, the Iranian event of 31 August 1968 killed and injured thousands and caused extensive property damage but only registered 40 nm 0-to-peak at LASA, a 5.5 M_b . The event on 24 September 1968 from Turkey killed several persons, but it was only 13 nm 0-to-peak, a 5.3 M_b . It is not advisable to lower the alert threshold to the level of these examples due to the high false alarm rate expected.

During the period of the experiment, events 27 and 43 saturated the normal LASA system (earth motion in excess of about 368 nm 0-to-peak). Event 43 occurred after the short-period signal attenuation modification was completed (paragraph 2.2.1); thus, its amplitude and magnitude were obtained. Such attenuated signals are necessary for complete reporting of large events.

TABLE III

SEISMIC AMPLITUDE (M_b) FOR AN EVENT RESULTING IN 85 nm, 0-TO-PEAK,
GROUND MOTION AT LASA.

Distance, Degrees	Period, secs.									
	.6	.7	.8	.9	1.0	1.1	1.2	1.3	1.4	
20	5.2	5.2	5.1	5.1	5.0	5.0	4.9	4.9	4.9	
25	5.5	5.5	5.4	5.4	5.3	5.3	5.2	5.2	5.2	
30	5.7	5.7	5.6	5.6	5.5	5.5	5.4	5.4	5.4	
35	5.8	5.8	5.7	5.7	5.6	5.6	5.5	5.5	5.5	
40	5.6	5.6	5.5	5.5	5.4	5.4	5.3	5.3	5.3	
45	5.8	5.8	5.7	5.7	5.6	5.6	5.5	5.5	5.5	
50	5.8	5.8	5.7	5.7	5.6	5.6	5.5	5.5	5.5	
55	5.9	5.9	5.8	5.8	5.7	5.7	5.6	5.6	5.6	
60	6.0	6.0	5.9	5.9	5.8	5.8	5.7	5.7	5.7	
65	6.0	6.0	5.9	5.9	5.8	5.8	5.7	5.7	5.7	
70	6.0	6.0	5.9	5.9	5.8	5.8	5.7	5.7	5.7	
75	5.9	5.9	5.8	5.8	5.7	5.7	5.6	5.6	5.6	
80	5.9	5.9	5.8	5.8	5.7	5.7	5.6	5.6	5.6	
85	6.1	6.1	6.0	6.0	5.9	5.9	5.8	5.8	5.8	
90	6.1	6.1	6.0	6.0	5.9	5.9	5.8	5.8	5.8	
95	6.3	6.3	6.2	6.2	6.1	6.1	6.0	6.0	6.0	

Due to the small number of alert events, the analyst time spent on the events is negligible compared with that spent on all events detected by the LASA. Less than one-half hour is required to compute the epicenter parameters to report.

2.3.1.2 Conclusions and Recommendations

The purpose of the experiment was to determine the extent to which the LASA can participate in early notification of potentially destructive events. Although this conclusion should not and cannot be derived solely from the effort expended at LASA, certain other conclusions and recommendations can be made. These are:

1. A large event alert reporting system is feasible using the existing LASA on-line and off-line processing systems.
2. The 85 nm threshold is recommended to enable distant events of approximately 6.0 M_b to be detected and reported and to keep the false alarm rate low. The false alarms caused by large near events, glitches, and calibrations are not particularly distracting.
3. The attenuated short-period array is needed for magnitude computations of events that saturate the normal system.
4. If immediate reporting is secondary to complete analysis, the long-period attenuated subarray C2 signals can be used for M_S magnitude reporting (see paragraph 2.2.2).
5. The alert system can be readily implemented on a 24-hour basis if the users of this data find it necessary.

2.3.2 Well Drilling Noise Effect on LASA Data Analysis

An opportunity to observe the effect which noise from oil well drilling activity has on LASA seismic data analysis was afforded because of well drilling in the vicinity of site D2 during May and June, 1968. This concluding report contains the results of power spectral density computations on individual sensor data obtained during the drilling activity and supplements those results reported earlier (paragraph 2.3.2 of reference 1) which were obtained from an absolute value averaging technique on the analog sum data.

The following describes the Noise Data Set (2.3.2.1), discusses the Analysis of Noise Data (2.3.2.2), and presents the final conclusions (2.3.2.3).

2.3.2.1 Noise Data Set

Not all available oil well activity noise samples were selected for power spectral density computation, but those associated with drilling of Well #2 (see Table VIII, reference 1). This well is referred to as North Central Oil #3, N. P. Snyder, located NE, NE, Section 31, Township 9N, Range 46E. It was drilled to a depth of 5170 feet, plugged, and abandoned.

Signals from sensors 53, 73, 75, 82, and 84 of site D2 were subjected to power spectral density computation. Figure 2.36 shows the geographical location of these sensors with respect to the well being drilled. Computation was performed on signals prior to well drilling (noise sample 1 of reference 1) and during drilling at a depth of 3800 feet (noise sample 4 of reference 1).

2.3.2.2 Analysis of Noise Data

Figures 2.37 and 2.41 show superimposed power spectral density plots, uncorrected for instrument response, made from 5-minute data samples of before drilling and during drilling activity for the five D2 sensors noted above. The 0.2 to 0.4 Hz teleseismic noise in each figure appears normal subject to diurnal and seasonal variations. In fact there is great similarity between curves of each figure throughout the frequency band to approximately 2 Hz. Above 2 Hz, the power increases considerably for sensors 53 (Figure 2.37) and 73 (Figure 2.38) during drilling and substantially exceeds the teleseismic noise level. The plots for the other sensors, which are much further from the drilling activity, do not show this increase. The greatest drilling power appears at about 4.2 Hz, but the origin of this noise is at the moment unknown. Figure 2.42 shows the power density variation for each sensor at this frequency. It is evident that the power decreases with distance from the well.

The effect which this noise has on LASA data analysis based on the analog sum signal was discussed in reference 1 in which it was concluded that no deterioration of detection occurred. It is useful now to consider its effect on analysis of individual sensor data. Within the context of LASA off-line processing, whereby the data is filtered prior to analysis, it is apparent that the drilling noise lies within a frequency band appreciably above that of seismic interest. Thus, filtered time history plots should restore the appearance of the data to that which would exist without drilling activity. Three signals, each filtered and unfiltered, obtained during drilling activity are shown in Figure 2.43. The filter amplitude characteristic is shown in Figure 2.44. This is the filter used in the LASA off-line signal analysis routines. It is seen that some drilling noise remains from sensor 73 but is of low frequency.

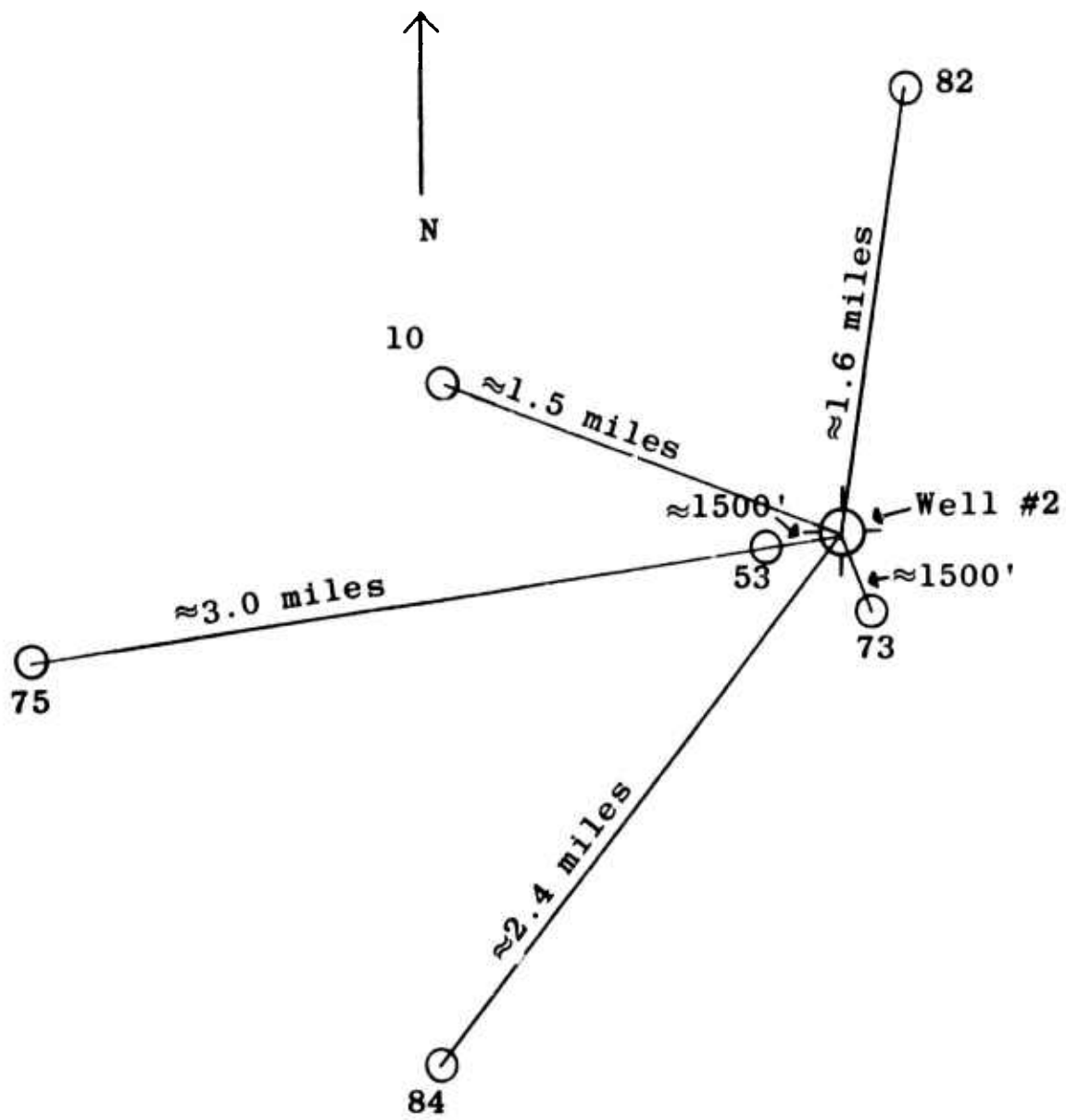

Figure 2.36 Site D2 sensor locations with respect to Well #2.

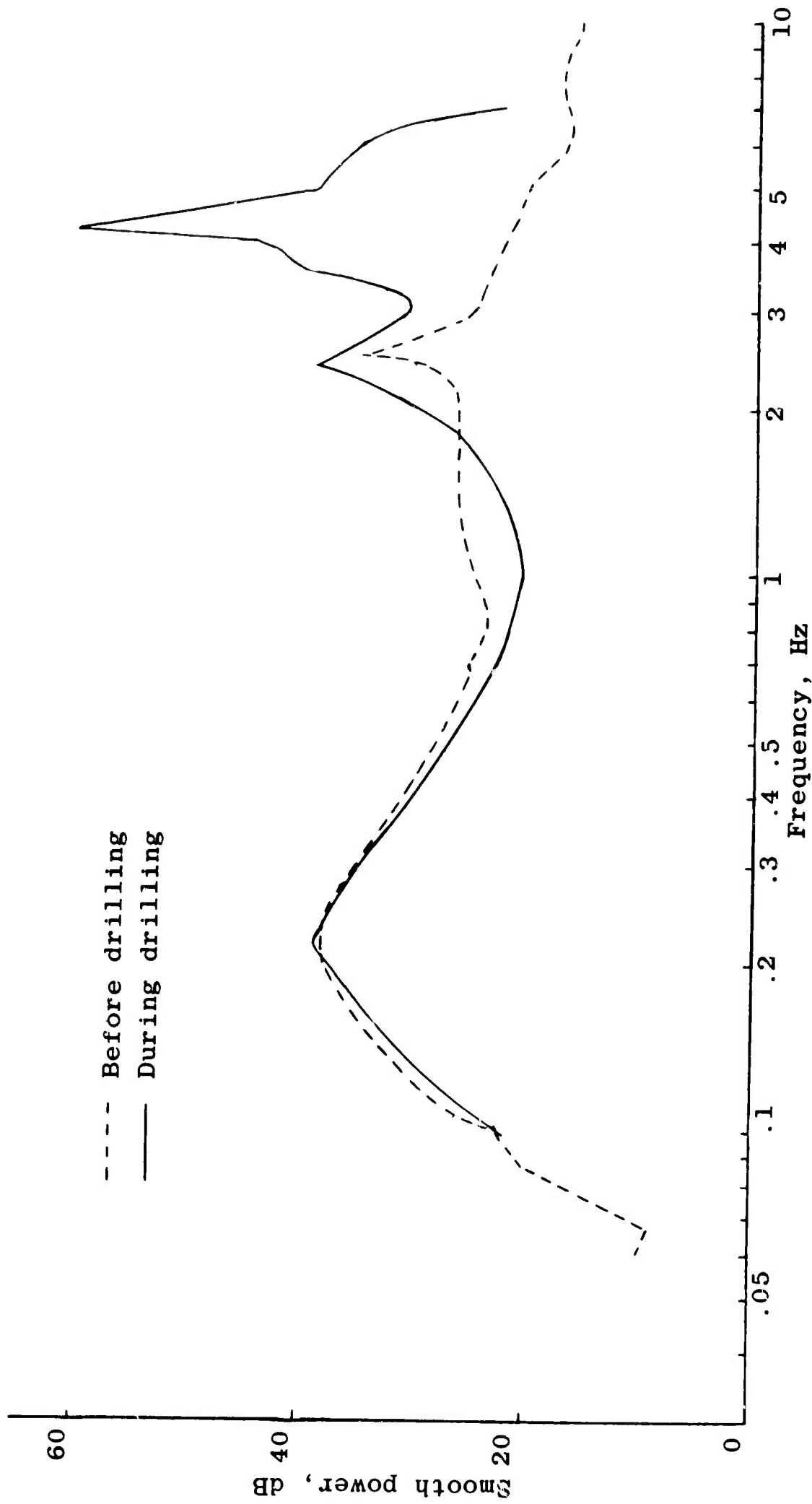

Figure 2.37 Power spectral density plot of D2-53 before and during drilling activity.

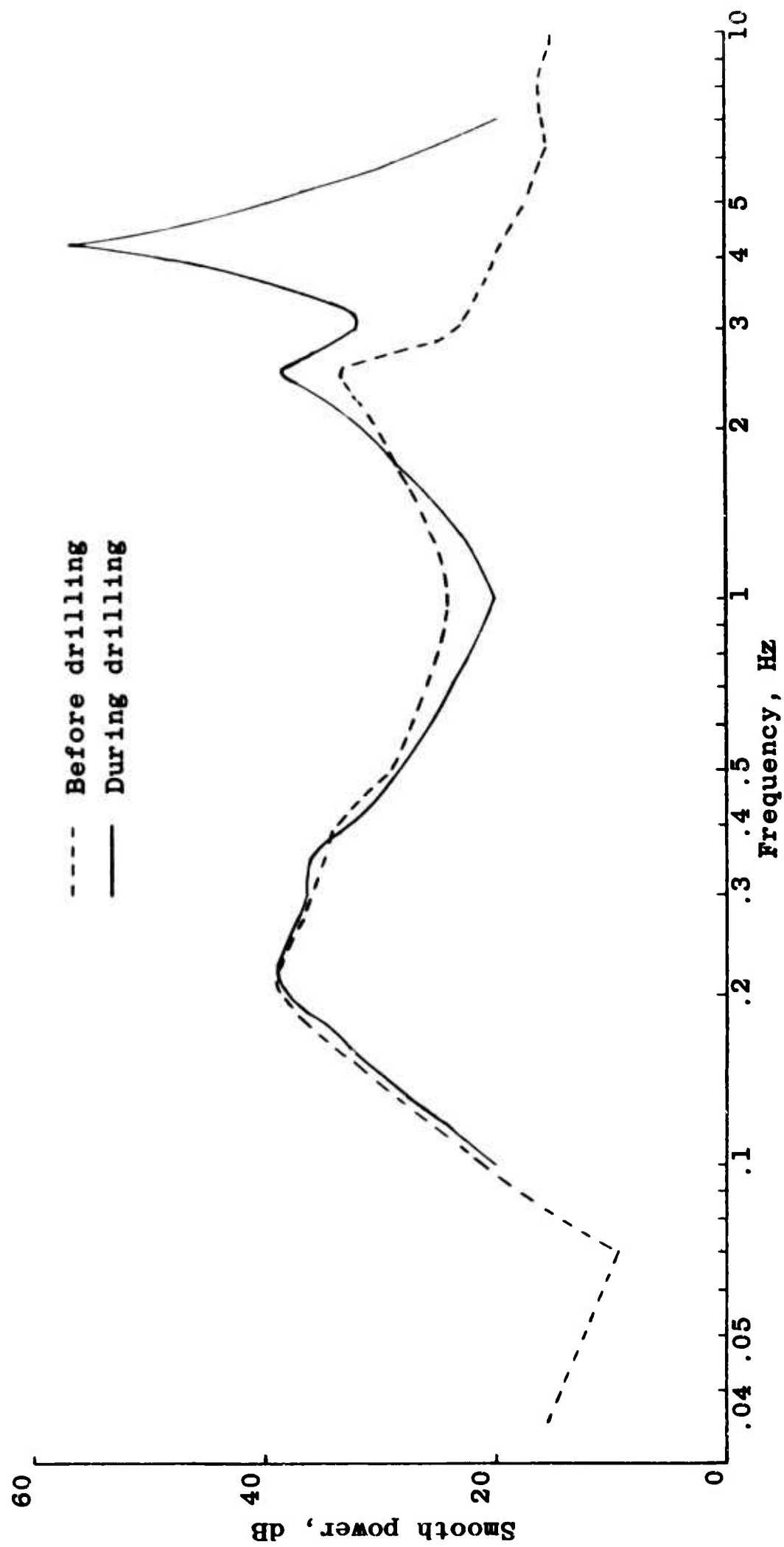

Figure 2.38 Power spectral density plot of D2-73 before and during drilling activity.

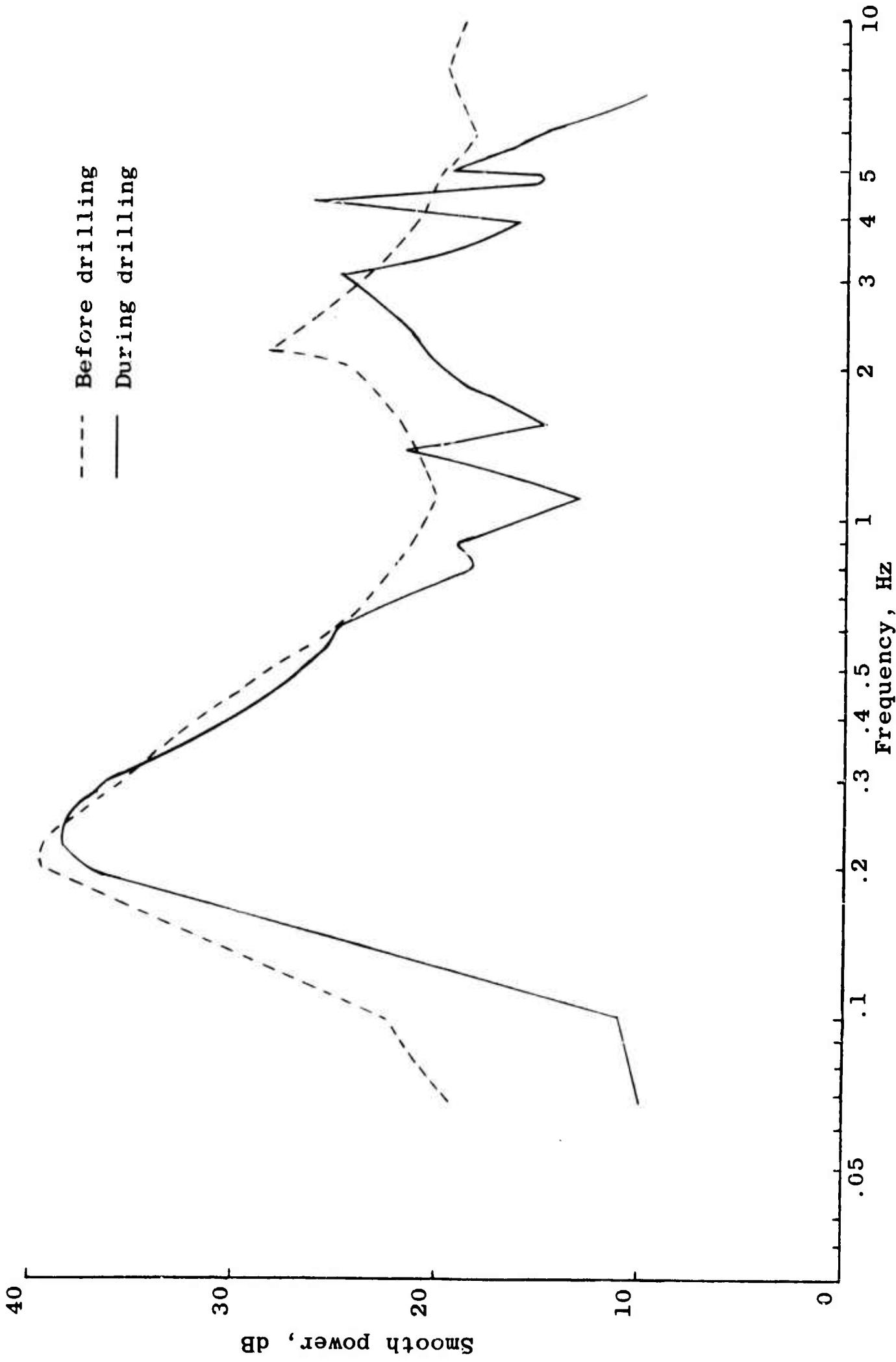

Figure 2.39 Power spectral density plot of D2-75 before and during drilling activity.

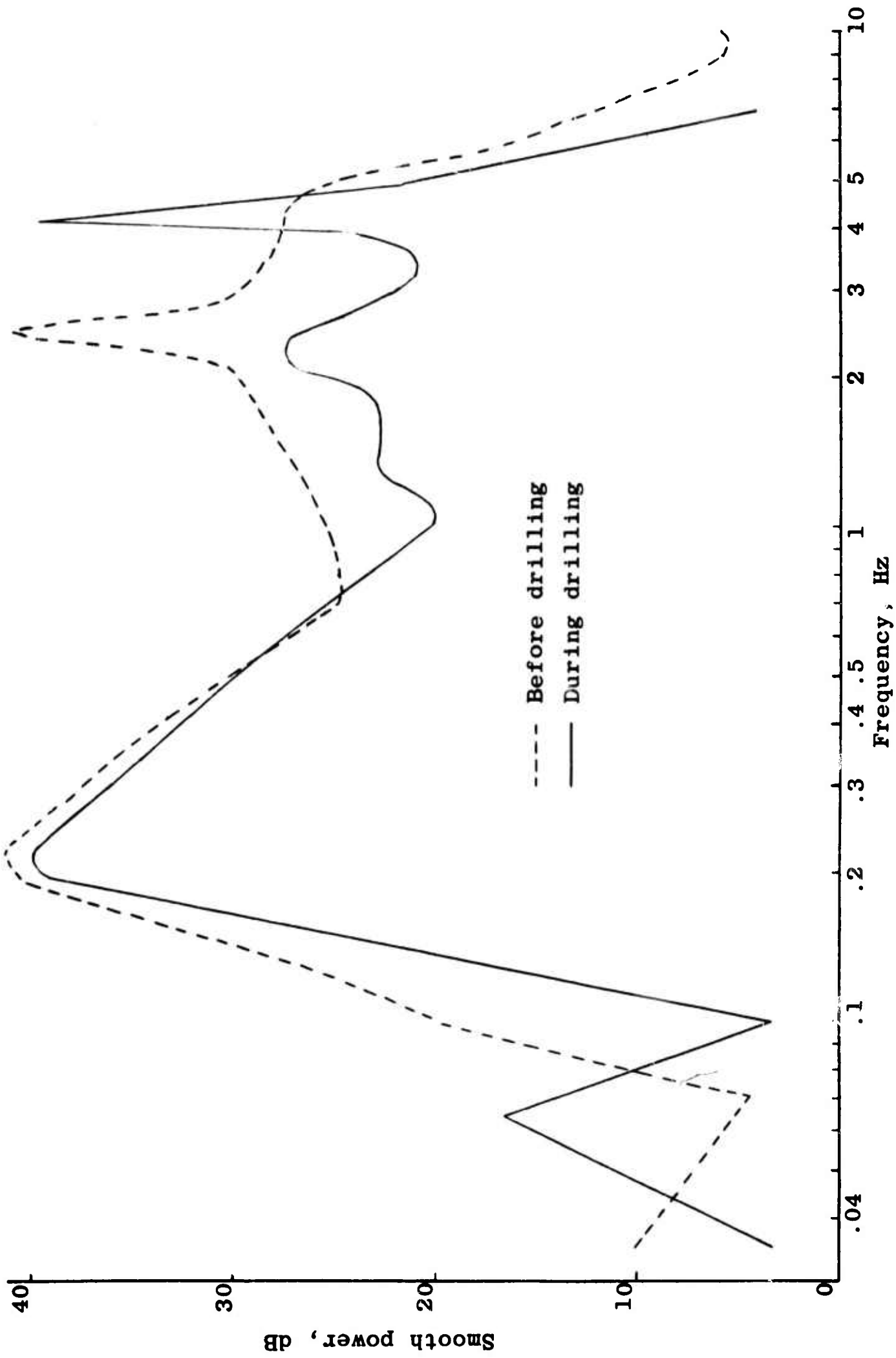

Figure 2.40 Power spectral density plot of D2-82 before and during drilling activity.

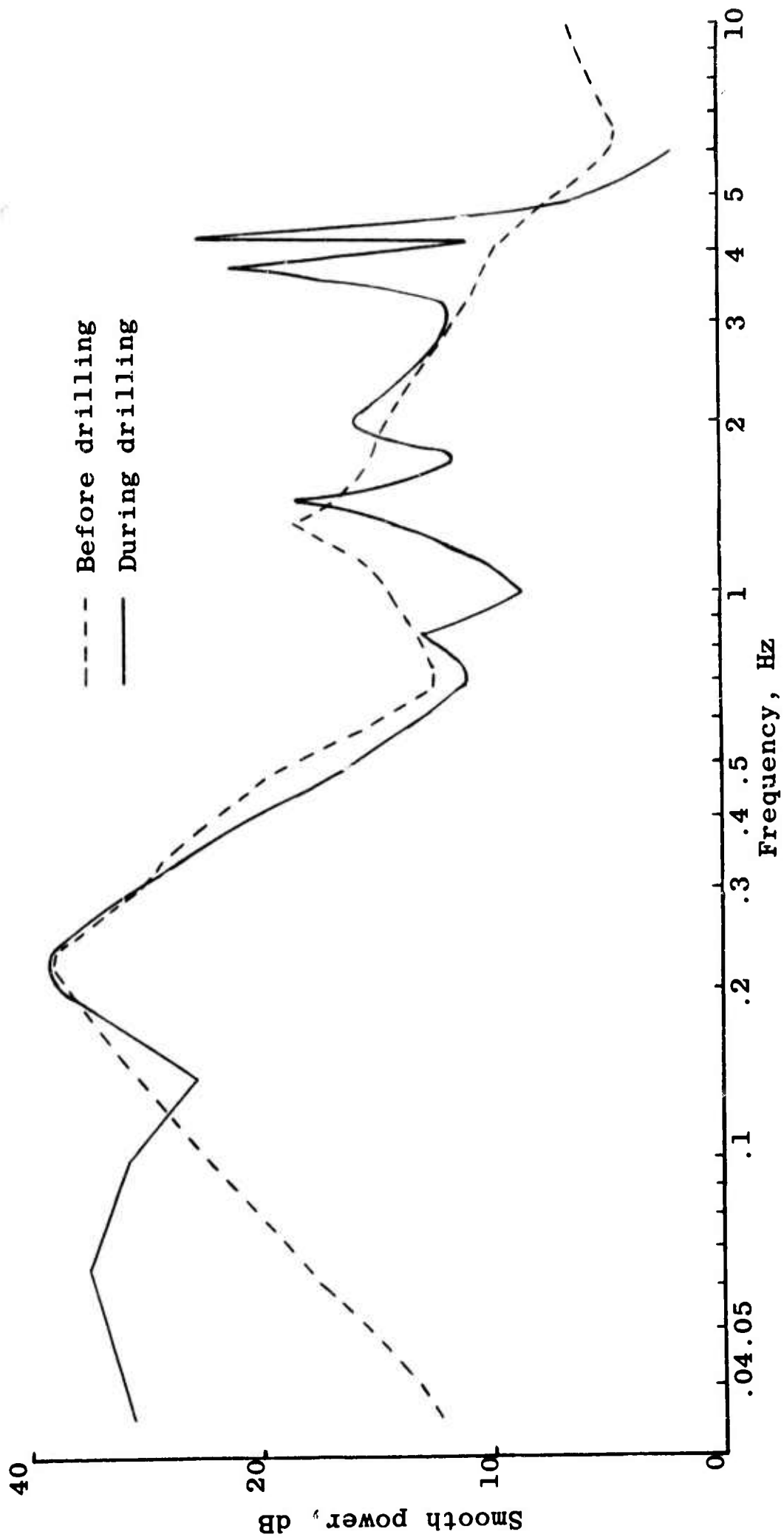

Figure 2.41 Power spectral density plot of D2-84 before and during drilling activity.

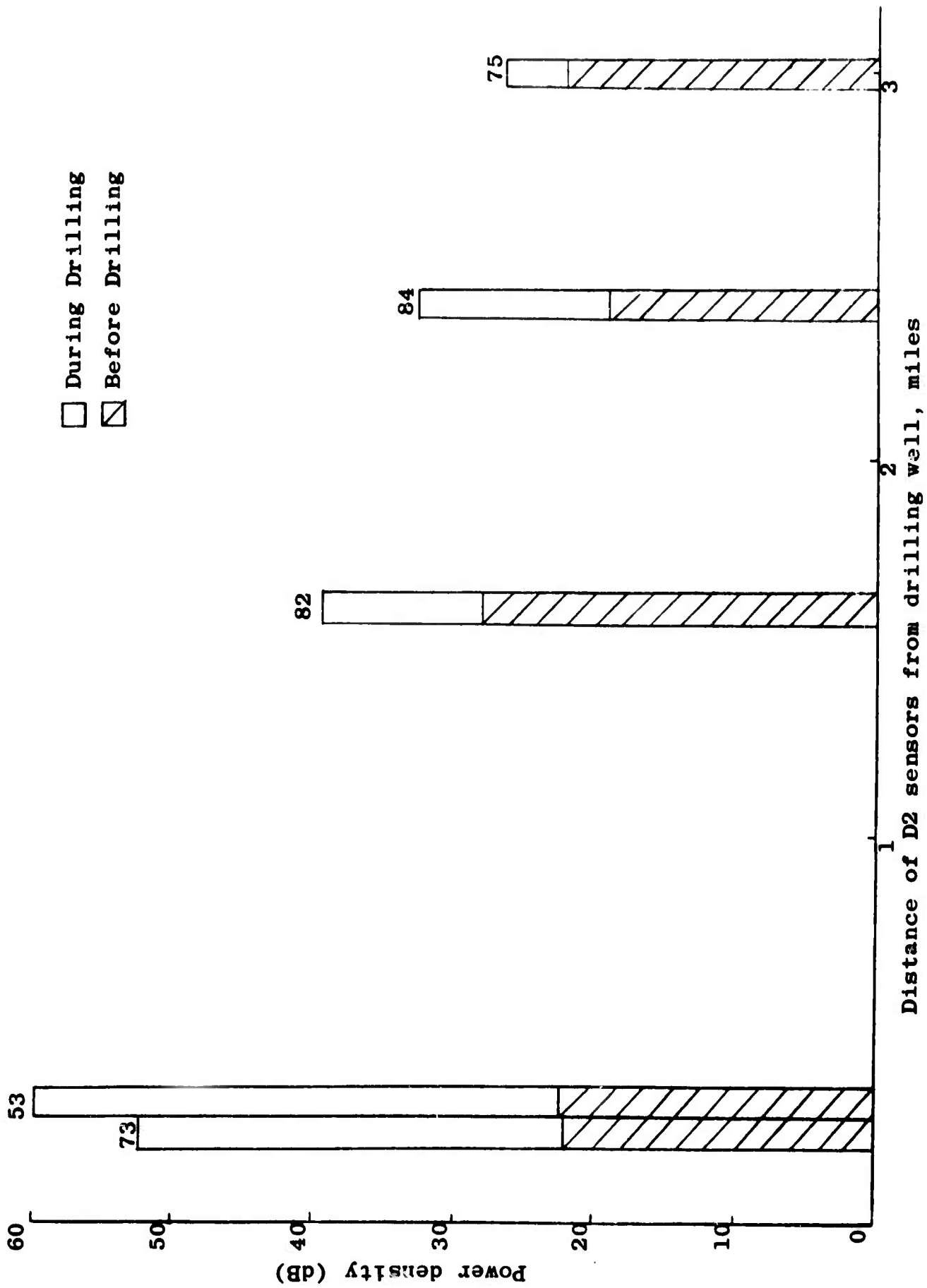
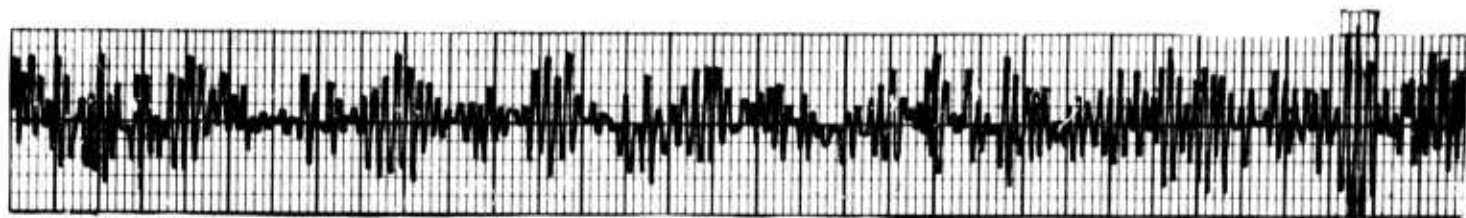
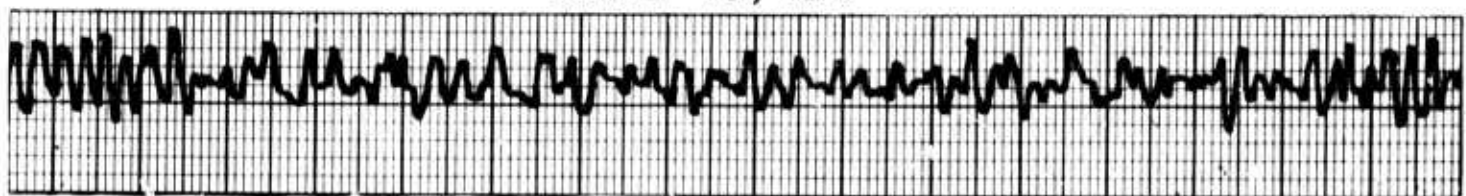

Figure 2.42 Power density at 4.2 Hz before and during drilling.



Sensor 73, Raw



Sensor 73, Filtered

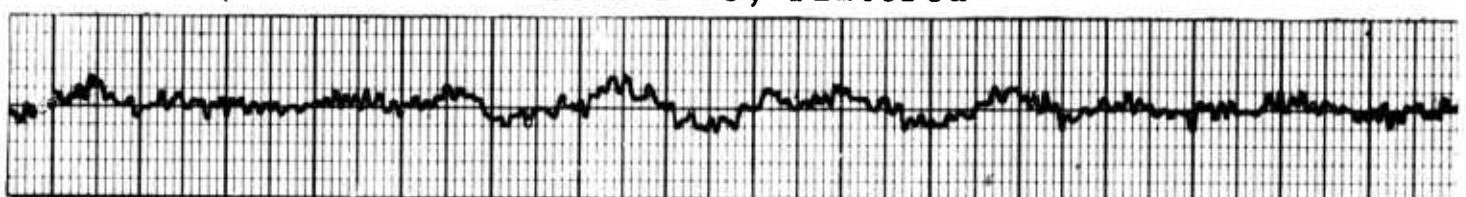

Sensor 82, Raw



Sensor 82, Filtered

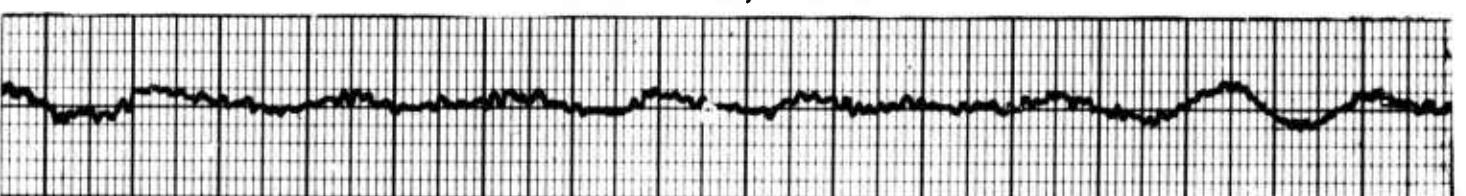

Sensor 75, Raw

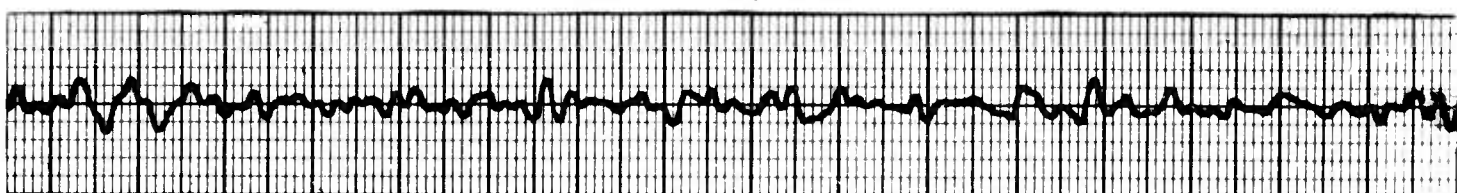

Sensor 75, Filtered

Figure 2.43 Effect of Butterworth Filter on drilling noise at D2 sensors 73, 82 and 75.

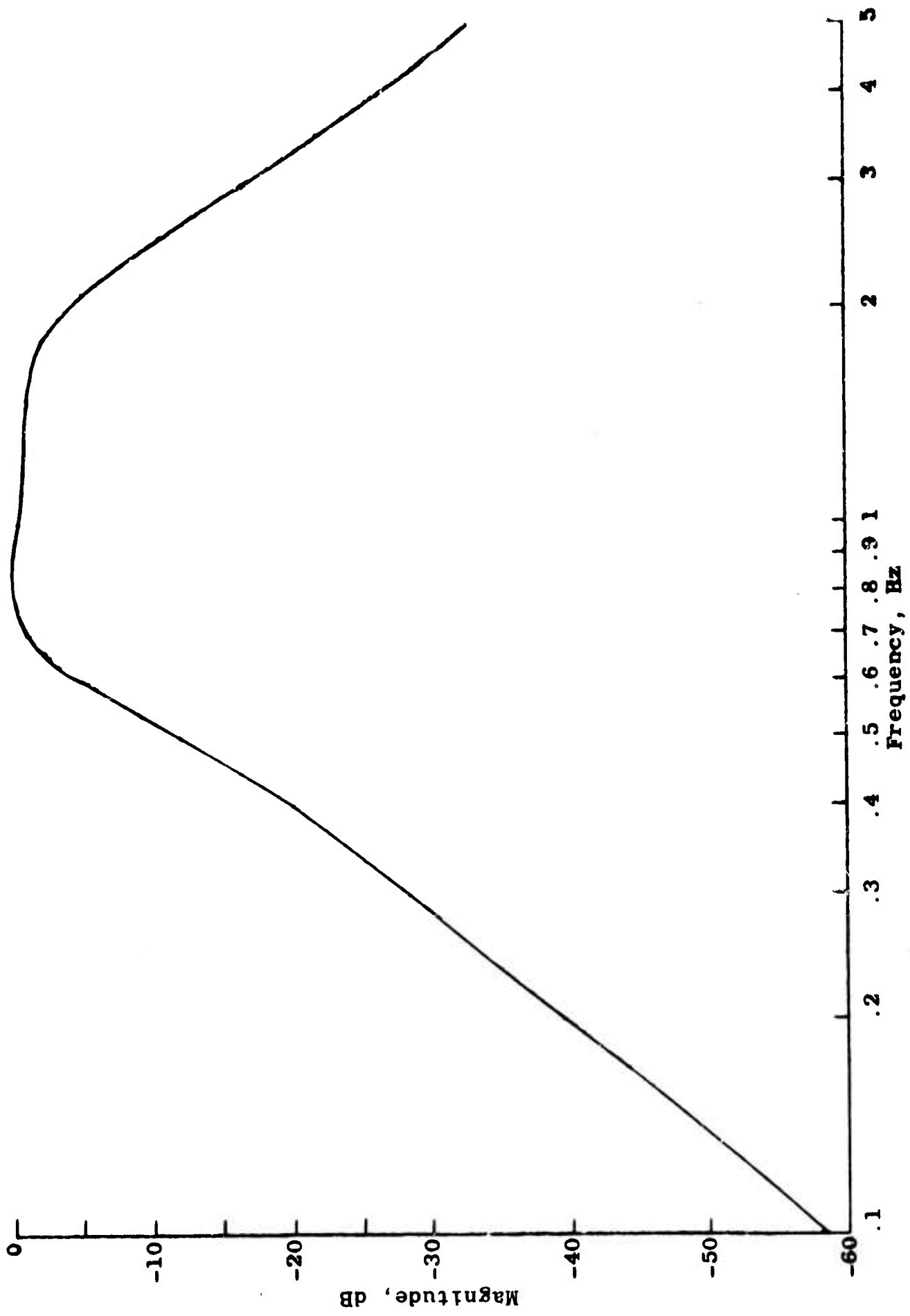

Figure 2.44 Amplitude characteristic of LASA off-line filter.

2.3.2.3 Conclusions

The foregoing and previous analysis of well drilling noise and its effect on the LASA data analysis leads to the following conclusions:

1. In order to adversely affect the analog sum signal which is used in the LASA on-line event detector, drilling activity must occur within about two miles of the subarray center hole. Even then, it is quite possible that the on-line filter will remove interfering signals such that the event detector will not trigger. In this respect there is no evidence that drilling noise is more severe than that due to weather.
2. In order to adversely affect an individual sensor signal subject to filtering in the LASA off-line system, drilling activity must occur within about one mile of the sensor.
3. Noise from surface movement of equipment contributes more to the analog sum signal than does that due to drilling. Inasmuch as the frequency components are lower there is a distant possibility that the event detector for a given subarray will trigger. However, the event false alarm rate is not expected to increase since the radius of interference is much too small to result in triggering of detectors operating on other subarrays.

2.3.3 Short-Period Seismic Signal Channel Phase Measurement

The primary objective of this experiment was to obtain quantitative data on the LASA short-period seismic signal channel phase shift (delay). A secondary objective was to investigate a means of measuring the phase shift which would be suitable for use in an automatic array maintenance and monitoring system, such as was previously operating within the LASA (references 2 and 3).

The signal channel phase shift is one contribution to station corrections and, thus, is directly related to the accuracy of epicenter determination. Station corrections developed over a period of time for fixed equipment configurations permit consistent epicenter computation. However, hardware maintenance and modification activity can substantially alter a signal channel response so that, with time, a given set of station corrections may be invalidated. It is thus necessary to measure signal channel phase shift limits in order to assess their importance to seismic signal processing.

One set of data utilized in this experiment was obtained from 384 short-period seismic signal channels. A short-period seismic signal channel is composed of the units shown in Figure 2.45. The second data set was obtained from each analog unit within most short-period channels from subarrays B1, E3, and F3.

The following includes a description of the Test Procedure (2.3.3.1), Discussion of Results (2.3.3.2), and Conclusions (2.3.3.3).

2.3.3.1 Test Procedure

There are two calibration signals available in the LASA from which short-period seismic signal phase information can be obtained. These are the pseudo-random sequence and the 1 Hz sine wave.

The pseudo-random sequence is used with a Fourier transform algorithm to produce a broadband magnitude and phase response. This method requires much data collection time and is unattractive for application to all channels of the array. However, it was applied at least once to the entire array but was not used for this experiment.

One technique used during this experiment paired the 1 Hz calibration signal with a cross-correlation algorithm using an abbreviated data base. The procedure is to apply the signal simultaneously to each sensor in a subarray. After allowing the initial transient to subside, data is taken for 10 seconds. Corresponding data points from all cycles for a given channel are averaged to reduce the effect of seismic noise and formed into single column matrices of 20 rows (corresponding to the 20 Hz sampling rate). The data from each seismic channel is then cross-correlated with the reference channel data to yield time delays from which the phase can be determined. Departure from the normal cross-correlation algorithm, applied to the truncated data, occurs by indexing so as to wrap around the data matrix to utilize all twenty data samples. The success of this method requires a sampling frequency integrally related to the frequency of the sine wave test signal. However, its fast execution time (real-time) on high signal-to-noise ratio data is a distinct advantage.

Finally, a standard cross-correlation algorithm is available which is applied to the 1 Hz signal appearing on the reference channel and each signal channel to yield time delays from which the phase can be computed.

2.3.3.2 Discussion

Figures 2.46 and 2.47 show the 1 Hz phase shift distributions for 384 signal channels and for 20 center hole channels, respectively. The abscissa of Figure 2.46 has two scales,

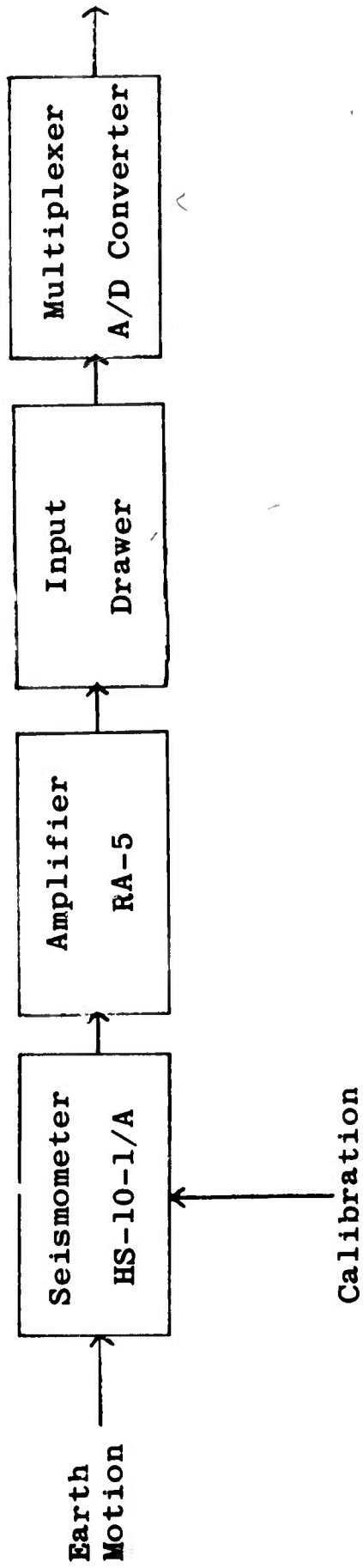

Figure 2.45 LASA Short Period seismic signal channel.

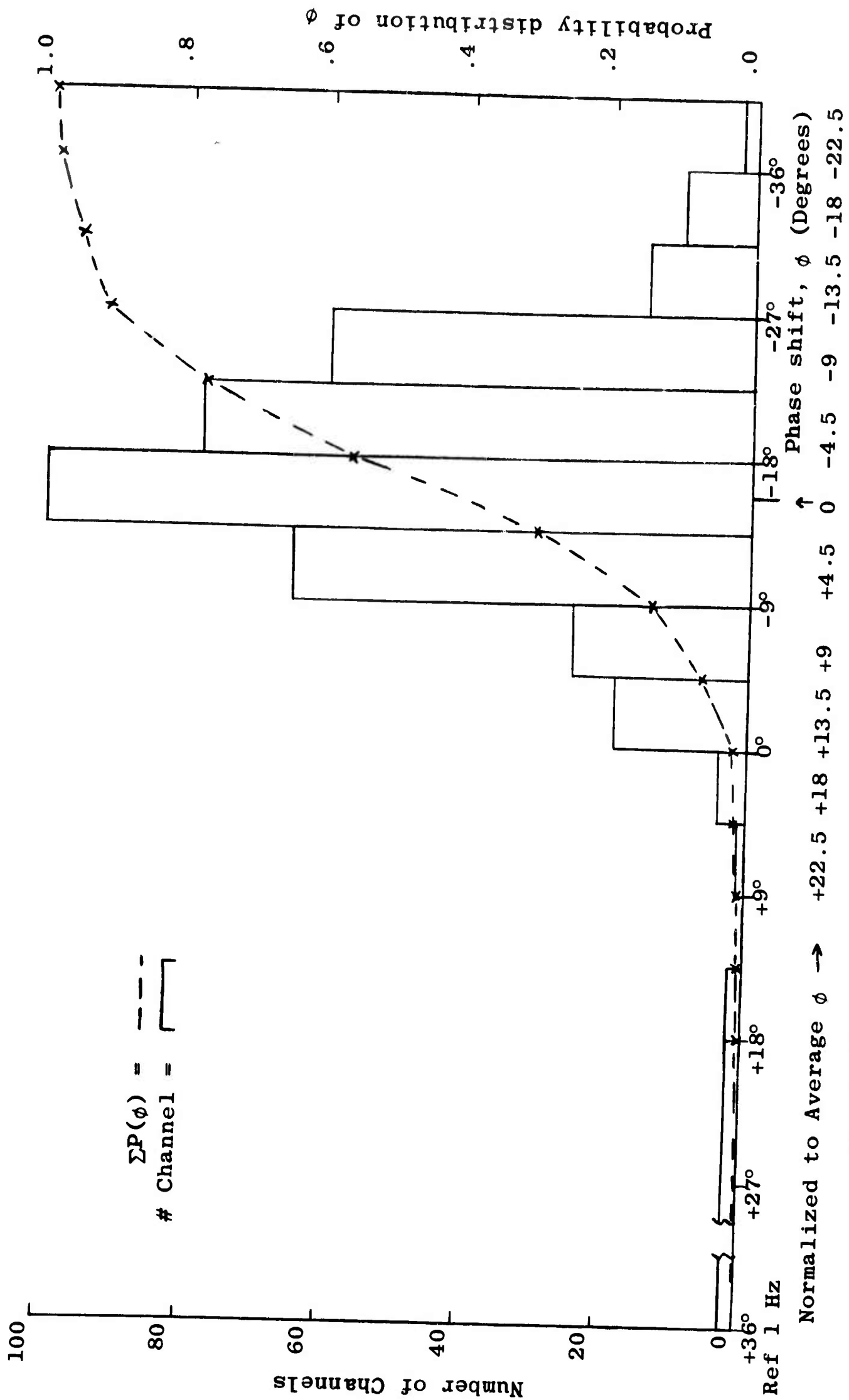

Figure 2.46 Channel phase shift distribution at 1 Hz.
(384 Channels)

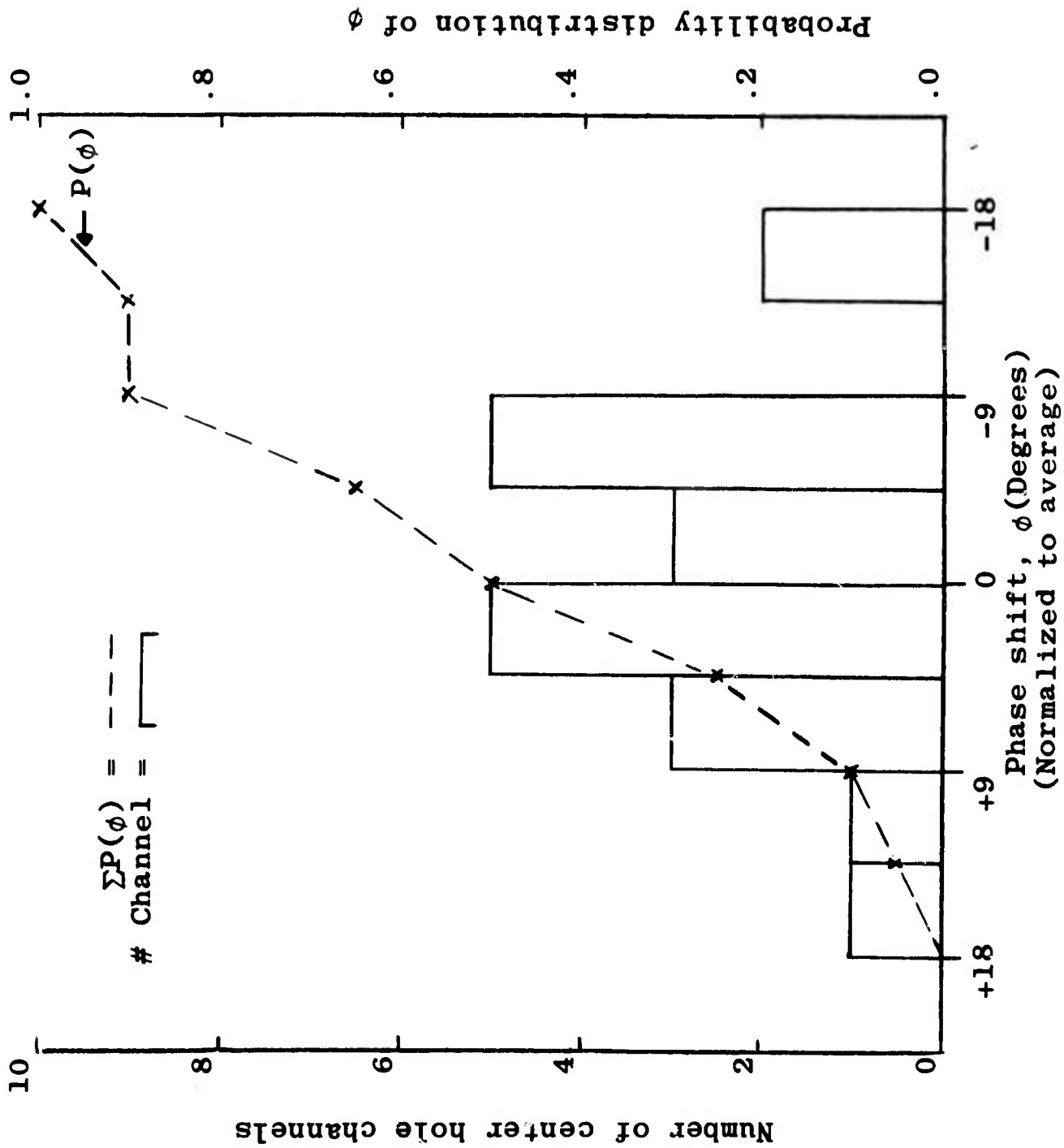

Figure 2.47 Channel phase shift distribution at 1 Hz.
(20 center hole channels)

one is the absolute phase shift relative to the reference oscillator while the other is normalized to the average sensor group phase shift. The range between the 90 percentile levels is 23.5° (0.0652 seconds) for the set of 384 sensors and 18.0° (0.05 seconds) for the center hole sensors. This phase shift computation was made by the abbreviated cross-correlation technique. The phase shift measured at 1 Hz for the RA-5 Amplifier and Input Amplifier Units appears in Table IV. These computations were made by the standard cross-correlation method. These data show that the phase shift at 1 Hz for these units is relatively constant and any variations in the channel delay can be attributed to the seismometer characteristics. Figure 2.48 shows the seismometer phase shift distribution at 1 Hz for units at B1, E3, and F3. These distributions are similar to those obtained for the cumulative channel phase shift (Figures 2.46 and 2.47). The natural frequency of the sensor was determined from the measured phase shift by using Figure 2.49 which is a plot of the seismometer phase angle versus natural frequency for different damping values.

A field test was performed to determine the usefulness of the phase measurement technique for determining the seismometer characteristic. The test concerned the following:

1. Accuracy in using phase measurement for determining sensor natural frequency.
2. Effect of seismometer orientation on natural frequency.
3. Effect of RA-5 detector voltage level on channel phase response.

From the results of the seismometer phase measurement it was determined that sensor B1-42 had a 1 Hz phase shift of -51.8° . Using Figure 2.49 the natural frequency of this sensor should be between 1.5 and 1.8 Hz. The sensor was removed and the natural frequency was found to be 1.43 Hz. The replacement sensor had a natural frequency of 1.035 Hz and when installed its 1 Hz phase was -86.5° , which gives a natural frequency between 1.03 and 1.05 Hz according to Figure 2.49. Thus, the natural frequency obtained in this manner appears low but since only two samples were tested, it is suggested that further effort precede any conclusion from this test.

The second part of the test involved measuring the change in phase shift due to tilt by rotating original sensor B1-42 in the hole of three additional orientations, not accurately determined. The maximum change in 1 Hz phase angle was 1.9° , or approximately .05 Hz, which was about 3.5% of the 1.43 Hz natural frequency.

The last part of the test consisted of setting the detector voltage of the RA-5 amplifier unit at high speed and low levels and measuring the phase shifts. There was no difference

TABLE IV

1 Hz PHASE SHIFT OF INPUT AND RA-5 AMPLIFIER UNITS

Site	Input					RA-5				
	No. Chan.	Ave.		$\pm\sigma$		No. Chan.	Ave.		$\pm\sigma$	
		ms	deg	ms	deg		ms	deg	ms	deg
B1	18	-88.5	-31.9	1.7	0.6	16	24.2	8.7	3.6	1.3
E3	25	-92.1	-33.2	3.0	1.1	14	29.8	10.7	4.5	1.6
F3	15	-87.0	-31.3	2.5	0.9	23	22.4	8.1	1.6	0.6
Ave. of above		-89.7	-32.3	3.4	1.2		26.1	9.4	4.9	1.7
Range, ($x \pm 3\sigma$)		-79.5 to -99.9 ms -28.7 to -35.9 deg					40.8 to 11.4 ms 14.5 to 4.3 deg			

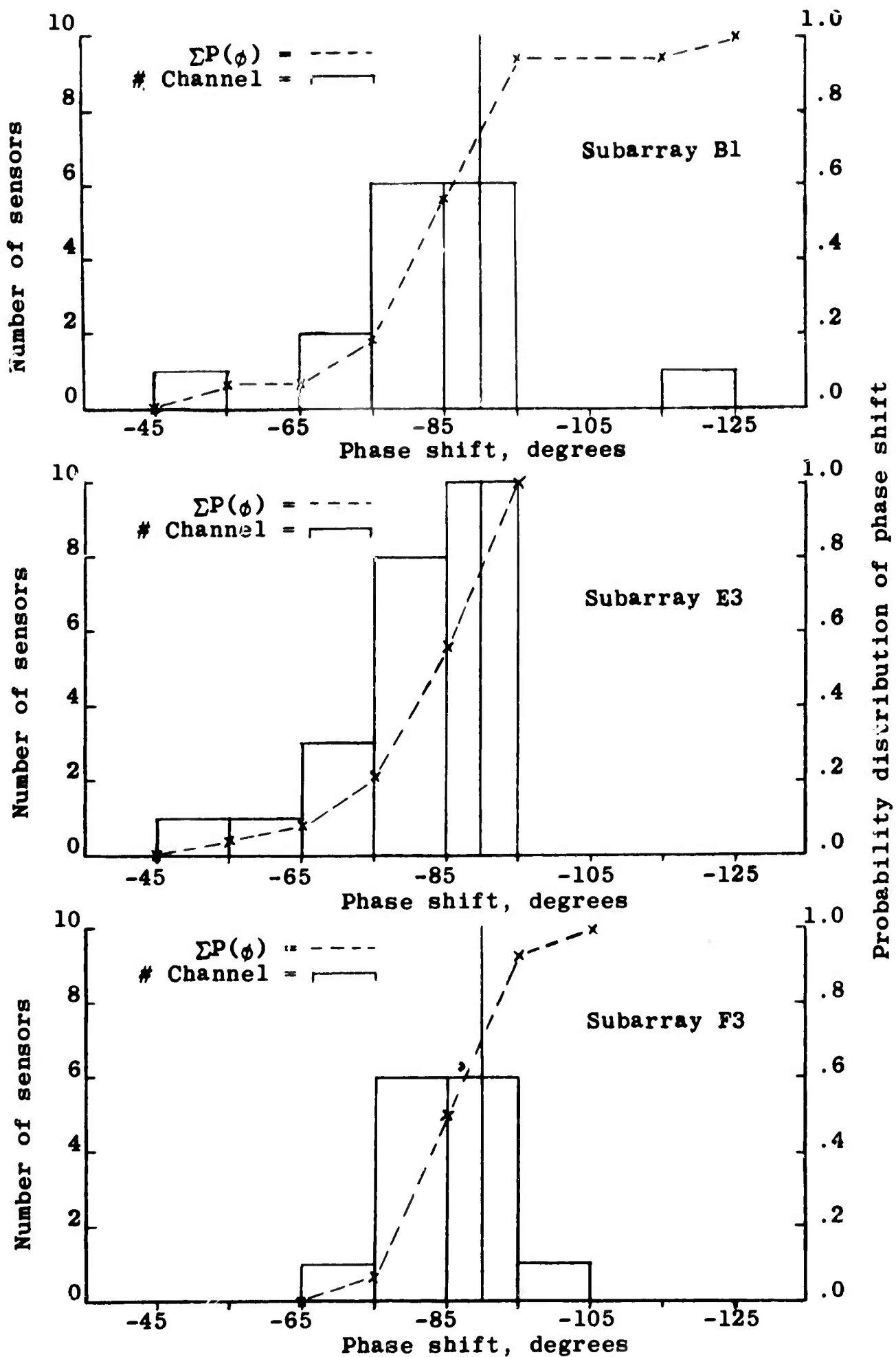

Figure 2.48 Seismometer phase shift distributions at 1 Hz.

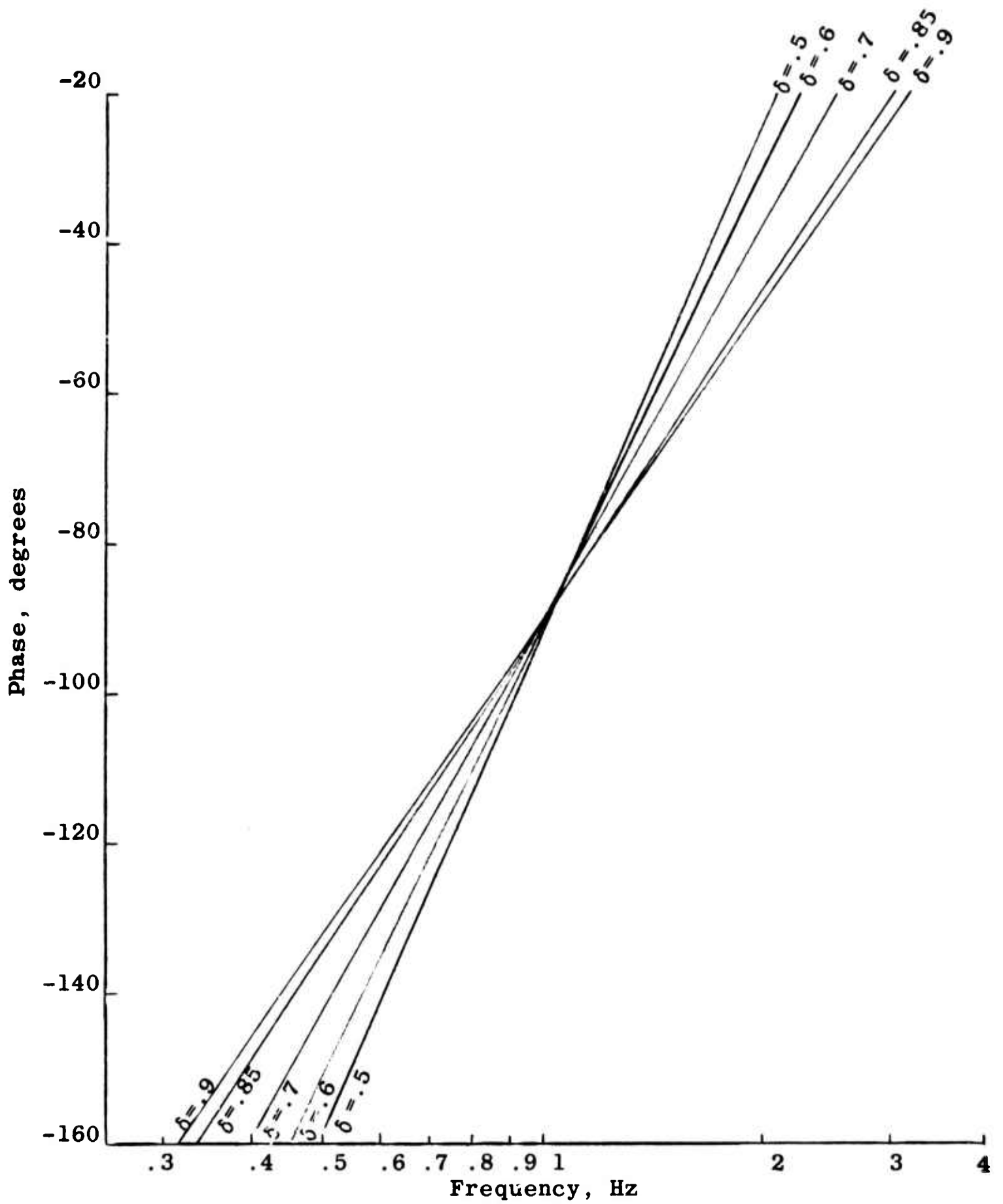

Figure 2.49 Seismometer phase shift vs. natural frequency.
(Forcing frequency equal to 1 Hz)

in the phase measurement between these two voltage settings.

2.3.3.3 Conclusions

The results of the experiment lead to the following conclusions with respect to the objective:

1. The 90% range in a LASA short-period seismic channel phase shift for a 1 Hz sinusoidal forcing function is about 65 ms while the extremum is 218 ms, as measured on 384 channels. The corresponding figures for 20 center hole channels are 50 and 100 ms, respectively. These figures are well within the lower range of station corrections measured for the LASA (reference 6). Thus, should precise results be required from LASA, it may be necessary to determine whether current published LASA station corrections have been invalidated due to seismometer replacement for the channel(s) of interest. Such replacement could occur through maintenance and/or modification activity.
2. Phase shift computation, by means of the abbreviated cross-correlation technique on channel data obtained from a sinusoidal calibration signal with respect to the reference channel is fast and convenient. Thus, this technique should be considered for an automatic array maintenance and monitoring system.

It can also be concluded that the LASA short-period seismic channel phase shift variation is due principally to the HS-10-1/A seismometer while that variation due to the RA-5 Amplifier and the Input Drawer Amplifier is negligible in comparison.

The data base used in the experiment in which the seismometer natural frequency was to be determined, for which seismometer orientation versus natural frequency was to be measured, and for which the influence on phase shift of the RA-5 amplifier detector voltage was to be measured, was too small to consider the results seriously. Thus, it is recommended that such measurements be repeated on a larger population in order to obtain confident results.

2.3.4 Microbarograph Data Recording

The PDP-7 computer on-line system was modified to implement full-time recording of a microbarograph data tape. Recording is accomplished by feeding the data, one word at a time, to a Kennedy Model 1500/H5/EC incremental magnetic tape recorder. Tape character density is 556 bpi.

These data being recorded consist of: 8 channels from Response A250 Model LTV-6 microbarographs, 13 channels from Response C125 ESSA (NBS) microbarographs, 1 channel from a Response B1667 Model LTV-6 microbarograph, 9 channels from standard LASA vertical-component long-period seismometers, and 4 channels from wind speed, wind direction, atmospheric temperature, and barometric pressure instruments.

All data are sampled at a 2 sample-per-second rate and recorded in the sequence shown in Table V in the tape and record formats of Figure 2.50. The header for each record consists of a time code (Figure 2.51) which is identical to the LASA high rate and low rate magnetic tape time codes. The one minute of data per record together with the time code words result in a record length of 4,202 words (12,606 tape characters). A 2400-foot reel of tape contains approximately 20 hours of real-time data. As a result, this format is referred to as the very low rate (VLR) format.

On-line recording of microbarograph data is combined with the normal LASA functions of high rate and low rate data recording, seismic event detection, and beamforming (24 hours/day, 7 days/week).

Typewriter input of a start command causes a sample of data to be transferred to the 35 word microbarograph buffer (only one buffer is required). When the incremental recorder is ready to record data, the Interrupt Line from the interface (Figure 2.52) signals the computer that data can be accepted. (Interrupts from the interface can be enabled or disabled under program control.) Data is placed into the PDP-7 accumulator and an Input/Output Transfer (I/OT) is executed. The I/OT Data Transfer pulse stores the accumulator data in the 18-bit holding register of the interface and starts an oscillator within the interface and control logic. This oscillator drives a count-of-three circuit which disassembles the 18-bit word into three 6-bit characters and sequentially transfers them to the incremental recorder Data Lines. Step pulses signal the recorder when to record data. The Interrupt Line is inhibited from making further data requests while recording. Upon completion of a full cycle of the timing logic, during which three 6-bit characters are recorded on tape, the Interrupt Line is raised for the next computer word. This process continues each half second until a full record of data has been transferred at which time the computer outputs an Inter-record Gap command. The End-of-file Mark is written in the same manner. During the writing of data, Inter-record Gaps, or End-of-file Marks, the interface is inhibited from making data requests.

Tables VI and VII list the various control and data signals and their function. Figure 2.53 is a photo of the incremental recorder, interface chassis, and power supply within one rack.

TABLE V
MICROBAROGRAPH TAPE DATA RECORDING SEQUENCE

Sequence Number	SEM Word	Site	Function	Sequence Number	SEM Word	Site	Function
1	2	A0	Temperature	19	18	C1	ESSA μ baro
2	6	A0	Wind Dir.	20	"	C2	"
3	7	A0	LTV-6 μ baro	21	"	B2	"
4	10	A0	Wind Speed	22	"	C3	"
5	14	F3	LTV-6 μ baro	23	"	D3	"
6	"	F4	"	24	"	D4	"
7	"	A0	"	25	"	D1	"
8	"	E4	"	26	"	D2	"
9	"	E1	"	27	26	F3	LP Z
10	"	F1	"	28	"	F4	"
11	"	E2	"	29	"	A0	"
12	"	F2	"	30	"	E3	"
13	15	A0	Barometer	31	"	E4	"
14	18	B1	ESSA μ baro	32	"	E1	"
15	"	A0	"	33	"	F1	"
16	"	B3	"	34	"	E2	"
17	"	C4	"	35	"	F2	"
18	"	B4	"				

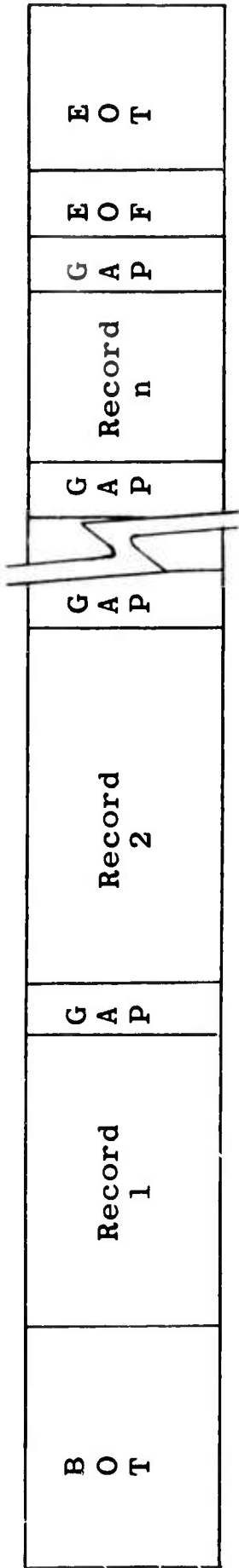

(a) Tape Format

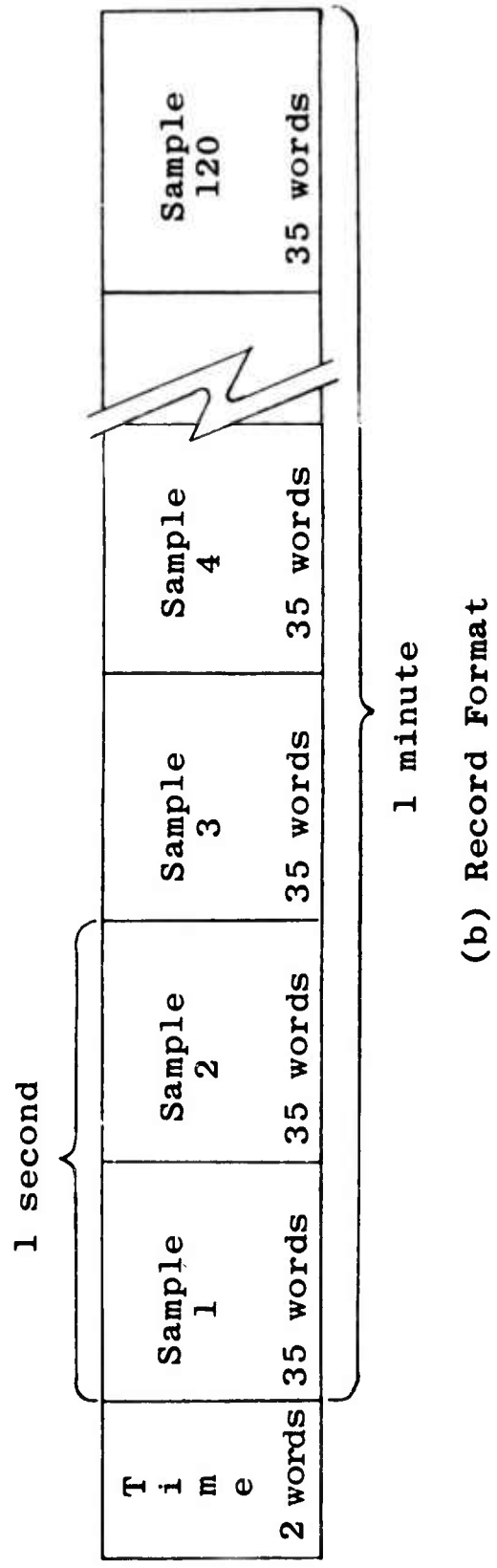

Figure 2.50 Microbarograph data recording format.

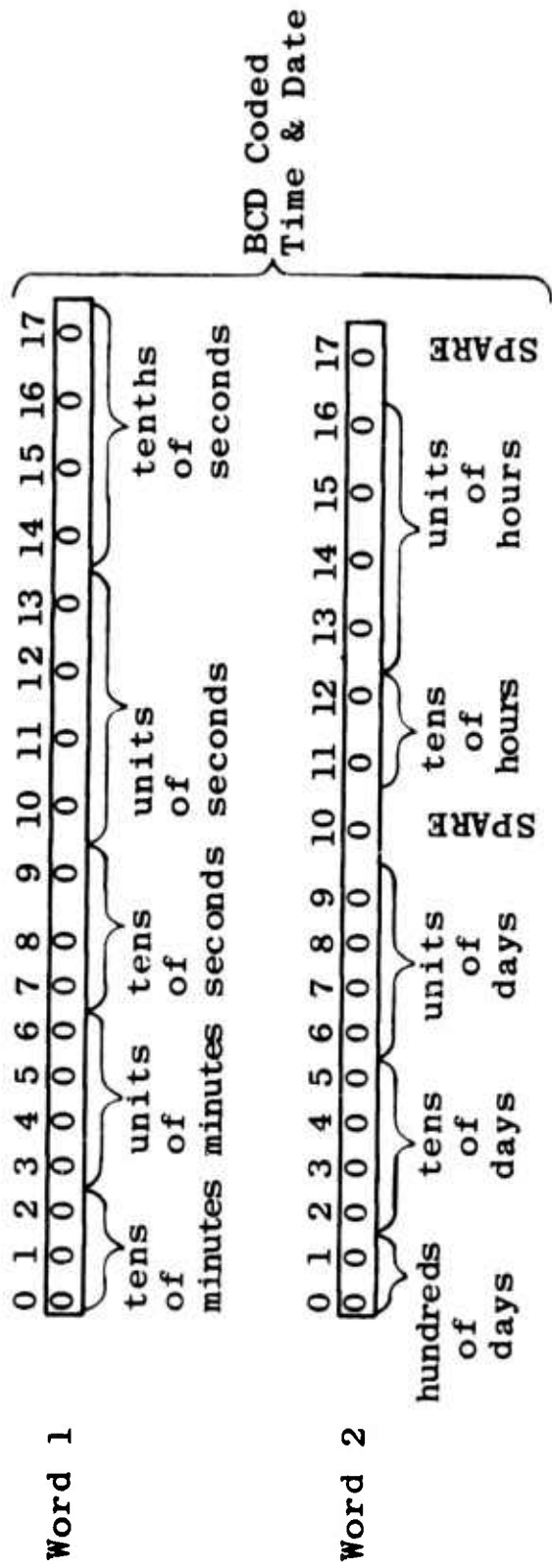

Figure 2.51 Time Word Format.

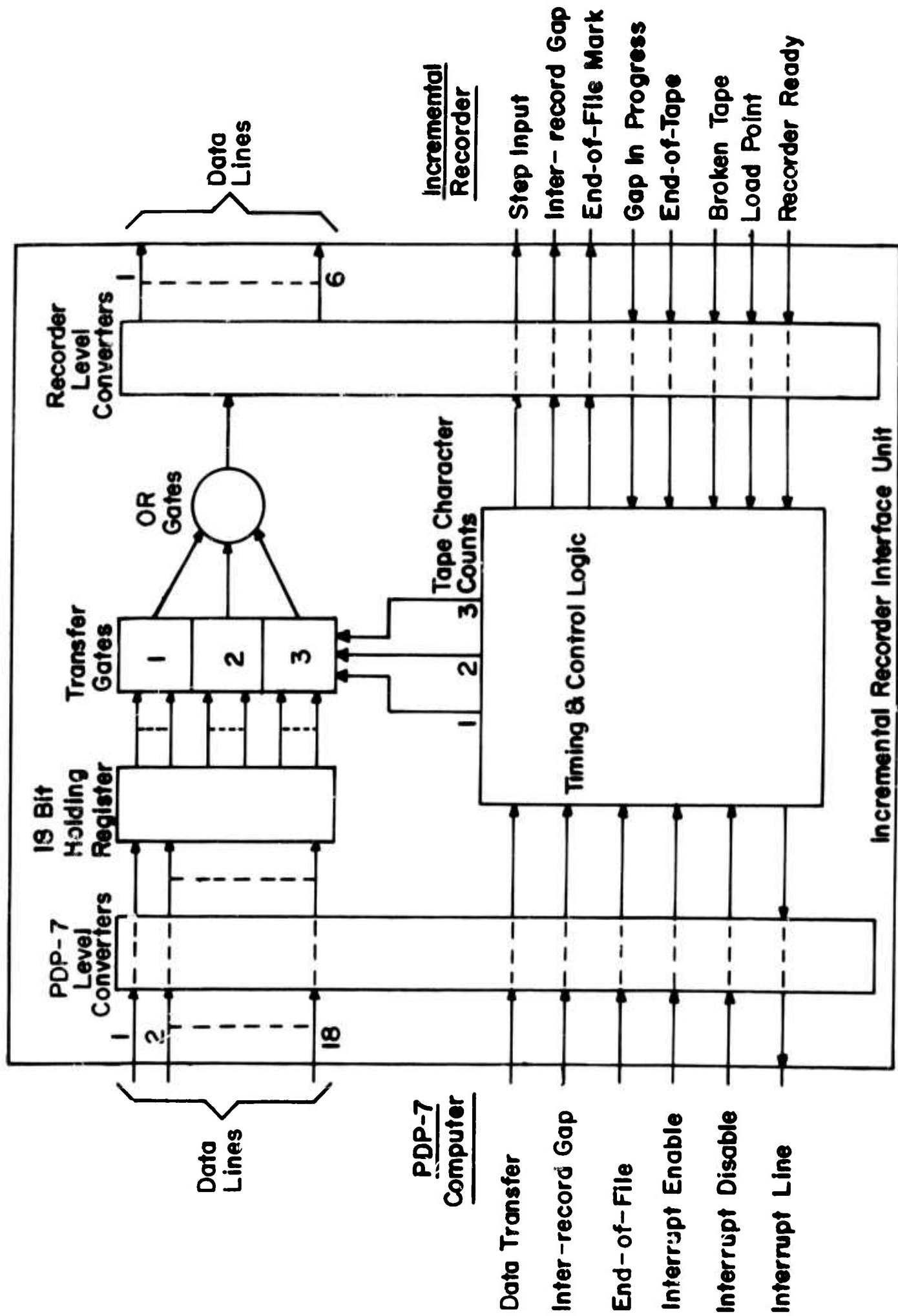

Figure 2.52 Incremental recorder interface unit functional block diagram.

TABLE VI

PDP-7 TO INCREMENTAL RECORDER INTERFACE SIGNALS

Signal	Function
Data Lines	Contain information from accumulator bits 0-17.
Data Transfer	Transfers accumulator data to the storage register and starts tape character transfer with Input/Output Transfer (I/OT) command 704301 (octal).
Inter-record Gap	Initiates writing of a 3/4-inch inter-record gap on tape with I/OT 704302.
End-of-file	Initiates writing of an end-of-file mark on tape with I/OT 704304.
Interrupt Enable	Enables the interface to generate interrupt data requests when the recorder can accept new data. Utilizes I/OT 704502.
Interrupt Disable	Disables the interface from generating interrupt data requests. Utilizes I/OT 704504.
Interrupt Line	Requests data from the computer. It is inhibited when the program has output the Interrupt Disable command, words are being written onto tape, a record gap or file mark is being written, the end of tape has been reached, the tape is broken, the tape is not in the correct position relative to the load point, or the recorder is not ready.
<p>Note: Negative logic (0 and -3 volts) for all signals. The Data Lines and Interrupt Line signals are sustained levels while all others are 350 nsec pulses.</p>	

TABLE VII
 INCREMENTAL RECORDER INTERFACE TO RECORDER SIGNALS

Signal	Function
Data Lines	Contain 6-bit tape character information. Positive logic (0 and +8 volts).
Step Input	Initiates writing of one 6-bit tape character. Positive logic (0 and +8 volts) 1 ms. pulse.
Inter-record Gap	Initiates writing of the inter-record gap (450 ms). Positive logic (0 and +8 volts) 150 ms. pulse.
End-of-file Mark	Initiates writing the end-of-file mark. Positive logic (0 and +8 volts) 150 μ s. pulse.
Gap in Progress	Indicates that an inter-record gap or end-of-file mark is being written. Positive logic (0 and +10 volts).
End of Tape	Indicates that the end of the tape has been reached. Positive logic (0 and +10 volts).
Broken Tape	Indicates that the tape has broken. Positive logic (0 and +10 volts).
Load Point	Indicates that the tape has reached the load point. Positive logic (0 and +10 volts).
Recorder Ready	Indicates that the recorder is ready for operation. Positive logic (0 and +10 volts).



Figure 2.53 Incremental recorder interface and power supply equipment.

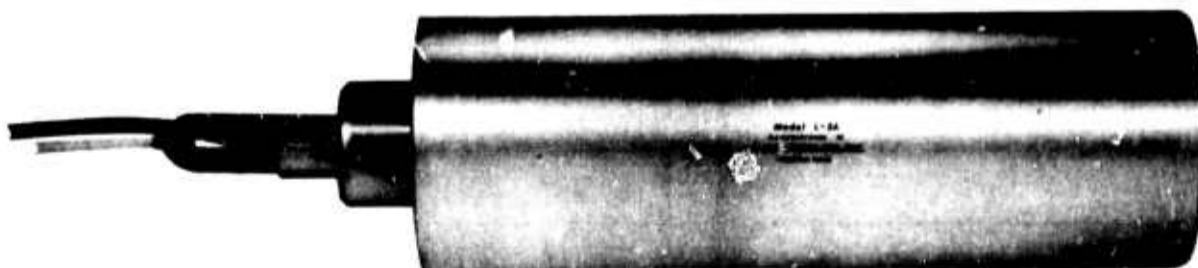

Figure 2.54 Mark Products Model L-3A seismometer.

2.3.5 Mark Products L-3A Seismometer Evaluation

The field evaluation of the short-period seismometer Model L-3A (Figure 2.54) from Mark Products, Inc., Houston, Texas, was terminated this quarter. Final test measurements were made and the seismometer returned to the manufacturer.

The seismometer was installed at location Bl-35 on 22 March 1967. During the evaluation period two laboratory evaluations and four field evaluations were performed. The evaluation tests are described in detail in reference 7. The seismometer operated satisfactorily in the present LASA sensor environment. The calibration coil motor constant is greater than that of the standard LASA seismometer, Geo-Space Model HS-10-1A; therefore, for normal operation of the array remote calibration function an attenuation circuit was designed and installed at the sensor location with the seismometer.

2.3.6 USGS High Explosive Calibration of the LASA

The USGS representatives from the National Center for Earthquake Research, Menlo Park, California, ignited 15 high explosive shots near or within the LASA between 10 September 1968 and 13 September 1968.

The objectives of the experiment were to:

1. Determine near surface time delays and velocity anomalies in the upper crust.
2. Determine depth of intermediate crustal layers using wide angle reflections recorded from LASA and USGS seismometers.
3. Determine velocity of mantle arrivals across the array from three distant shotpoints.
4. Compare time delays determined from explosions with time delays from 25 earthquakes recorded during September and October 1968.

The LASA was augmented by 20 USGS seismic stations, 12 stations in the F Ring and 8 stations in the E Ring. Twelve 4,000-pound shots were fired within and just outside of the array. Three 20,000-pound shots were fired at a distance of 200 kilometers from the F Ring - to the northwest, to the northeast, and to the southeast. The shooting schedule is shown in Table VIII.

TABLE VIII

USGS HIGH EXPLOSIVE SHOOTING SCHEDULE

DATE	TIME GMT	NAME OF SHOT	LOCATION		SHOT SIZE
9/10/68	1100	Devils Tower	44° 50' N	104° 52' W	20,000#
9/10/68	1130	Sanders	46° 20' N	107° 03' W	4,000#
9/10/68	1200	Jordan	47° 20' N	106° 48' W	4,000#
9/10/68	1230	Hazel	46° 58' N	105° 20' W	4,000#
9/11/68	1100	Kingsley	45° 40' N	105° 27' W	4,000#
9/11/68	1130	McRee	45° 50' N	107° 11' W	4,000#
9/11/68	1200	Turner	48° 58' N	108° 03' W	20,000#
9/11/68	1230	Cabin Creek	46° 41' N	104° 41' W	4,000#
9/12/68	1100	Garland	46° 06' N	105° 49' W	4,000#
9/12/68	1130	Melstone	46° 41' N	108° 00' W	4,000#
9/12/68	1200	Horton	46° 17' N	105° 59' W	4,000#
9/12/68	1230	Cohagen	47° 09' N	106° 33' W	4,000#
9/13/68	1130	Axtell	47° 45' N	105° 20' W	4,000#
9/13/68	1200	Charlson	48° 08' N	103° 06' W	20,000#
9/13/68	1230	Baloney Hill	47° 45' N	107° 60' W	4,000#

USGS's requirements from the LASA Data Center were as follows:

1. Provide a desk and telephone at the LASA Data Center for the USGS representative.
2. Record the 15 shots on magnetic tape in the standard LASA High Rate format (20 samples per second). Duplicate and distribute these tapes as requested by USGS.
3. Have available an attenuated output from each SP subarray. The current 30 dB attenuation of the "10" signal at each subarray was sufficient.
4. Retain for 6 weeks, instead of the normal 4 weeks, High Rate tapes containing event signals beginning on 25 August 1968. Duplicate and distribute selected tapes as requested by USGS.
5. Send by mail daily the LASA Seismo Bulletin to USGS, Menlo Park, California.
6. Send LASA seismic films to the LASA Data Service as usual for distribution to USGS.

The LASA Data Center effort fulfilled all of the above requirements, and made hard copies of each of the shots for USGS.

BLANK PAGE

SECTION III

SEISMIC SIGNAL ANALYSIS

The data analysis effort this quarter represented a straightforward application of seismic analysis techniques to the LASA data to produce the daily Seismo Bulletin from which the statistics of paragraph 3.1 were obtained.

3.1 Statistics

During this quarter the seismic signal analysis effort has resulted in reporting, through the Seismo Bulletin, 3051 detected events. These 3051 events are classified as shown in Table IX. The analysis technique was continued as reported in reference 3.

A time history plot of the activity is shown in Figure 3.1 and the distribution of P phase magnitudes for located events appears in Table X. A swarm of events occurred in August from the Molucca Passage region (reported in Seismo Bulletin as North of Halmahera). The distribution of number of events per day appears in Figure 3.2. This distribution, with the exception of the above mentioned swarm on 9 August, is very similar to that previously encountered at the LASA. The mean and standard deviations are normal.

A time history plot of the number of false alarms appears in Figure 3.3 and their distribution per day in Figure 3.4. During this quarter there were only 2 days with more than 10 false alarms each.

TABLE IX
CLASSIFICATION OF DETECTED EVENTS

Event Classification	August	September	October	Total Events	Daily Average
Located teleseisms not including PKP's	377	387	332	1096	11.9
PKP Located	278	86	84	448	4.9
Poor or weak teleseisms (not located)	109	88	72	269	2.9
pP Phases	130	143	114	387	4.3
Other Phases	231	269	220	720	7.8
Regional or Near Regional	<u>37</u>	<u>63</u>	<u>31</u>	<u>131</u>	<u>1.4</u>
TOTAL EVENTS	1162	1036	853	3051	33.2

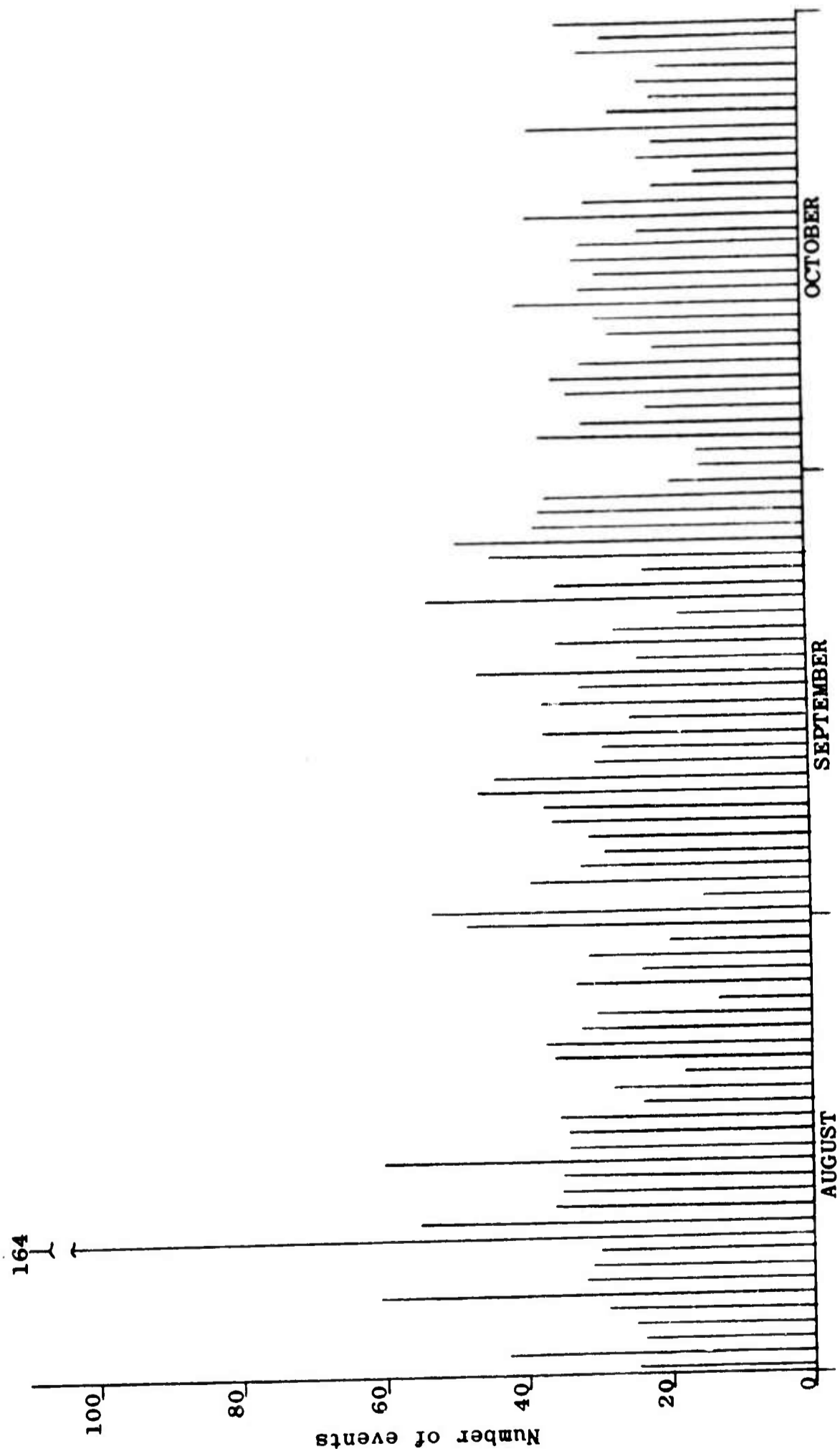

Figure 3.1 Distribution of total number of events by day.

TABLE X
MAGNITUDE OF LOCATED EVENTS

Event Magnitude	August	September	October	Total Events	Daily Average
< 4.0	37	26	27	90	0.91
4.1 - 4.5	183	174	142	499	5.4
4.6 - 5.0	102	119	107	328	3.6
5.1 - 5.5	41	48	39	128	1.4
5.6 - 6.0	9	15	14	38	0.4
> 6.0	5	5	3	13	0.14

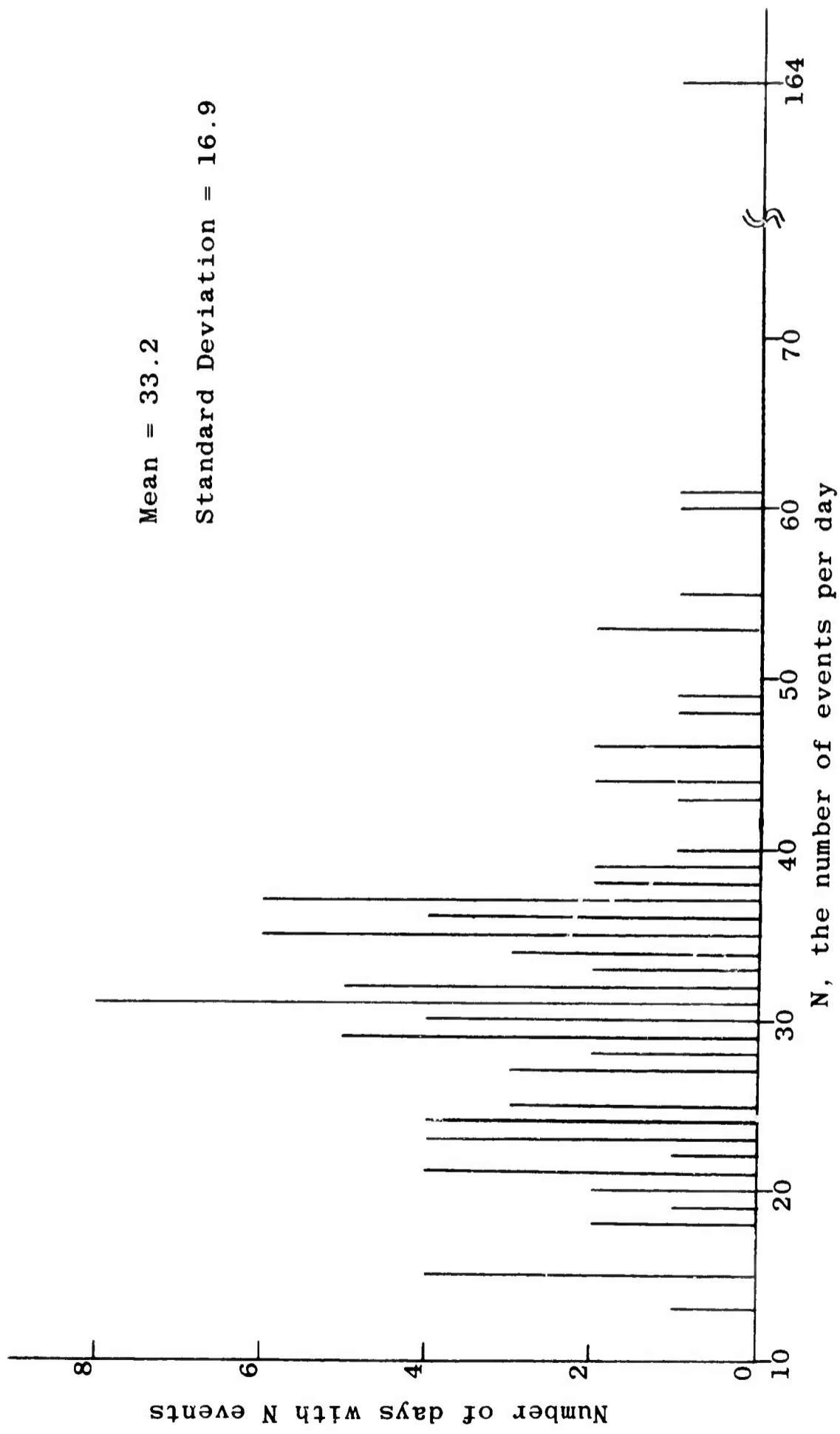

Figure 3.2 Distribution of total number of events per day.

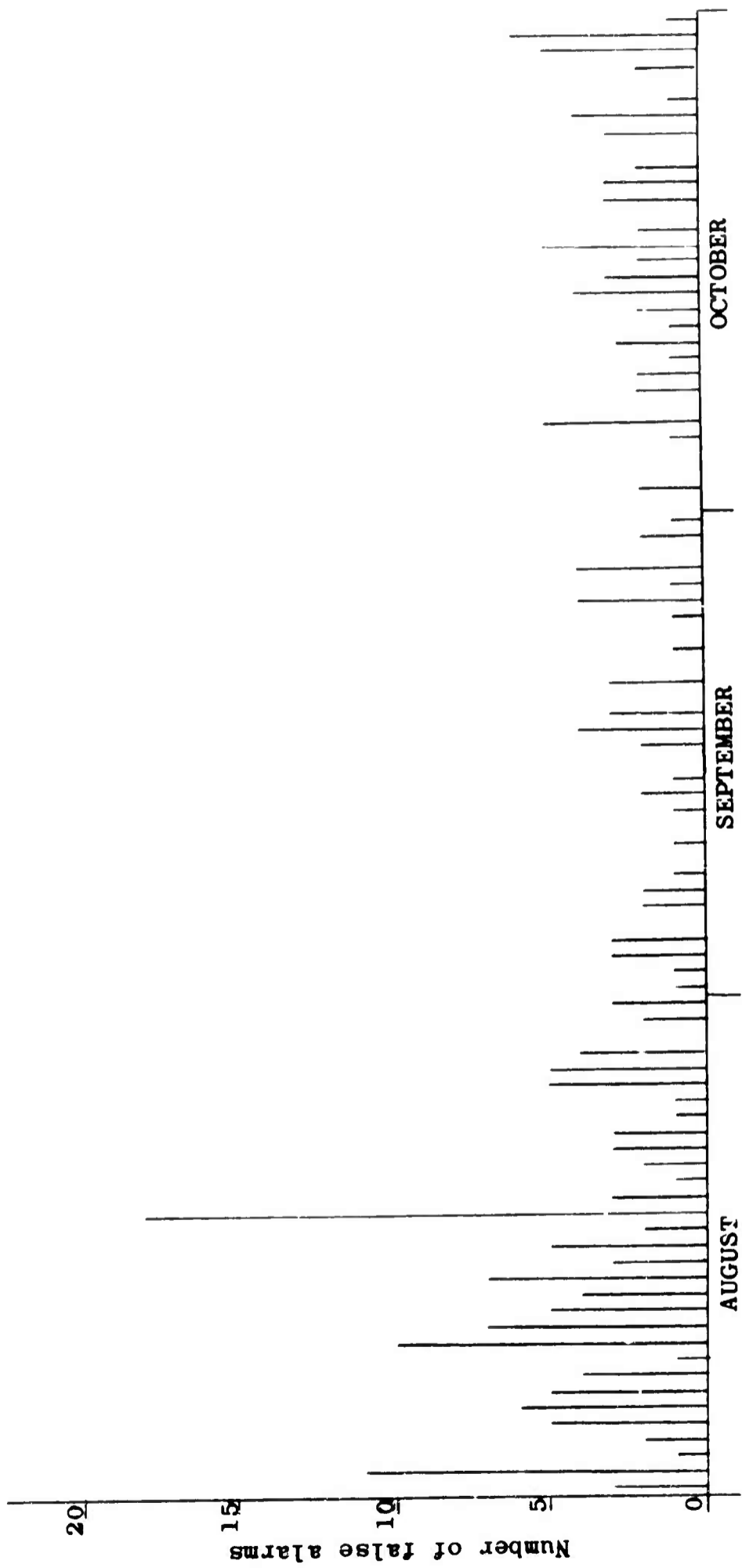

Figure 3.3 Distribution of the number of false alarms by day.

Mean = 2.6

Standard Deviation = 2.7

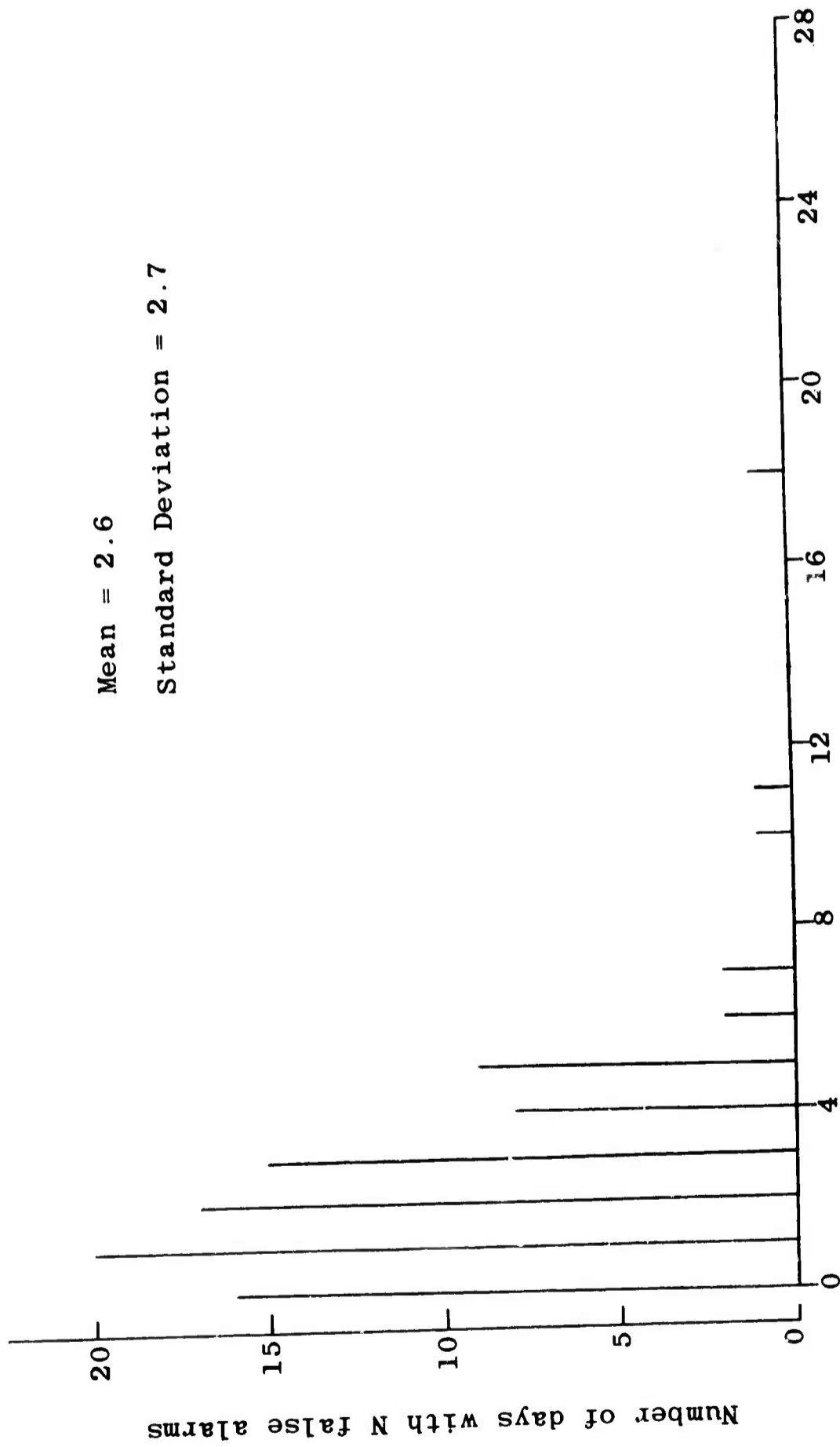

Figure 3.4 Distribution of the number of false alarms per day.

BLANK PAGE

SECTION IV

MAINTENANCE

Normal maintenance effort was applied to the LASA this quarter. The distribution of troubles was similar to that previously encountered. Two particularly disturbing array problems were resolved (4.1) but the usual spectrum of Data Center equipment problems were encountered (4.2).

4.1 Array

Array maintenance during this quarter consisted mainly of corrective maintenance to the LASA sensors. Figures 4.1 and 4.2 indicate the percentages of sensor channels out of tolerance for the long-period and short-period sensors respectively. An out of tolerance condition is determined from response to remote calibrations performed from the LDC maintenance console. It should be noted that sensor maintenance is not done at regular intervals. This is due to climatic conditions throughout the array and the priority of other LASA Maintenance Center activities. However, corrective maintenance is provided as the nature, distribution, and number of failures dictate to minimize the effect on array sensitivity.

Table XI contains a summary of the array equipment failures for this quarter. The definition applied to determine the number of failures, viz., 89, is "equipment received adjustment and/or component replacement to restore normal operation". Some sensor channel responses drift in and out of tolerance whenever the array experiences wide surface temperature variations. In these cases, unless an actual equipment adjustment is made, no failure report is prepared.

The largest number of sensor failures occur in the short-period amplifier and the long-period seismometer. The short-period amplifier failure results from the amplifier's sensitivity to the array environment, viz., amplifier gain variations with temperature. The long-period seismometer adjustment failures result from the seismometer mass moving against a mechanical stop due to the gradual tilting of the vault floor.

The large number of reported adjustment failures to the standby power system batteries resulted from routine servicing of the batteries and not actual failure. The batteries require the addition of water occasionally. Another failure occurred in the standby power system battery charger transformer. Since repair requires the replacement of the transformer, a \$240 item, corrective action to eliminate this type of failure is being initiated. A failure of this type also occurred during the first quarter.

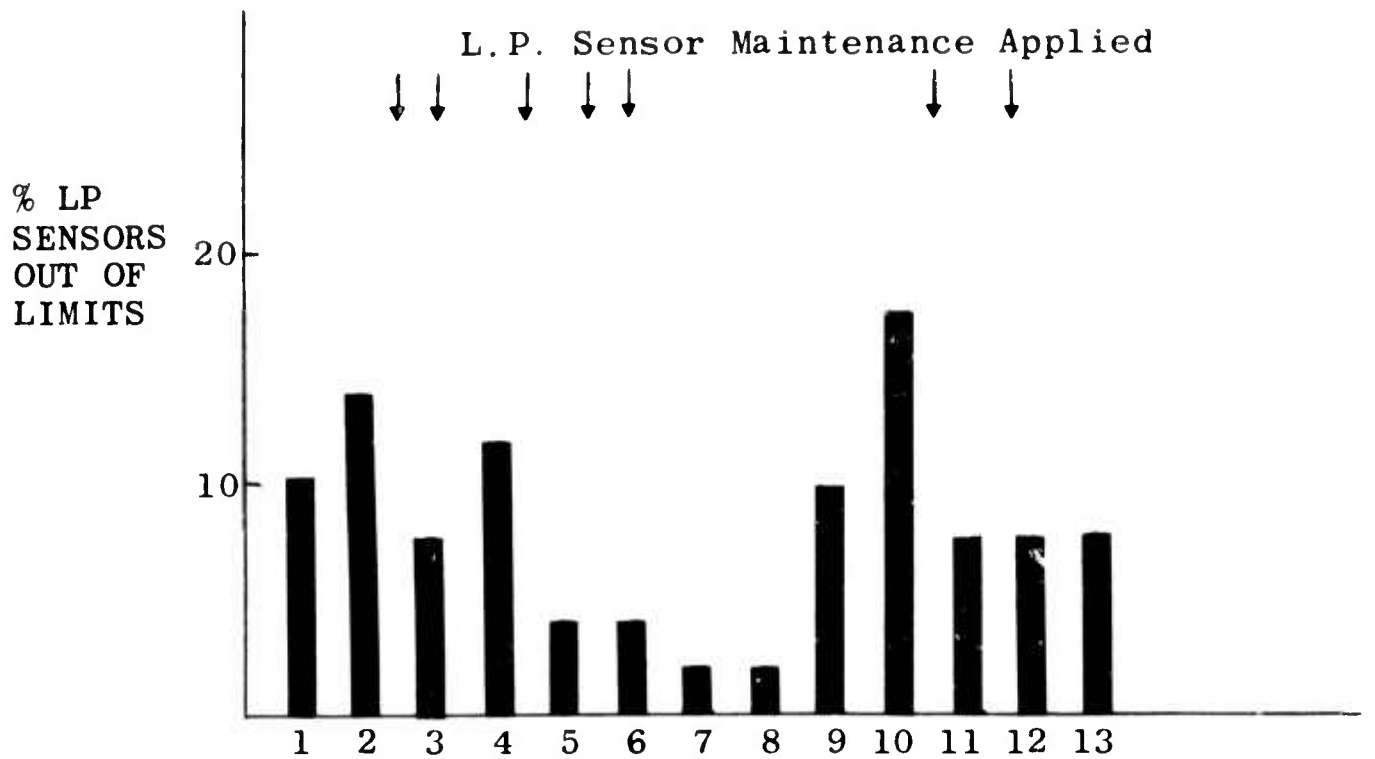

Reported percentage of LP sensors out-of-tolerance.

Figure 4.1

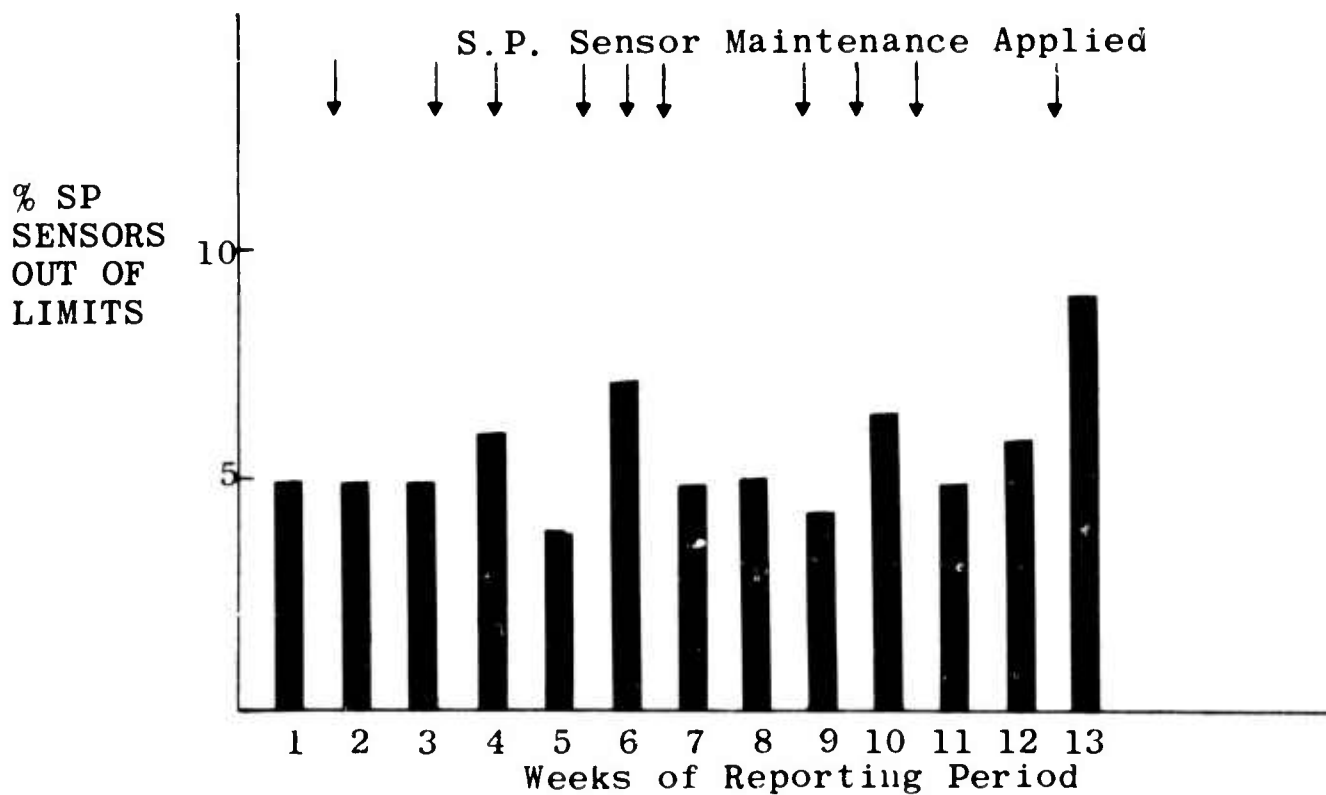

Reported percentage of SP sensors out-of-tolerance.

Figure 4.2

TABLE XI
ARRAY EQUIPMENT FAILURES

Equipment	Number of Failures	
	Component	Adjustment
Seismometer:		
Short-period	1	0
Long-period	0	5
Seismic Amplifier:		
Short-period	5	48
Long-period	0	1
SEM:		
Input	4	0
MUX	1	0
Output	0	0
Control	4	2
Seis. Amp. Power Supply	1	0
Auxiliary Control & Conditioning	0	0
Standby Power System:		
Charger	1	0
Battery	0	13
Inverter	0	1
Control	0	0
Weather Station	0	0
Microbarograph:		
LTV-6	0	0
ESSA	2	0
TOTAL	19	70

Investigation of another failure, ten of which have occurred in the LASA SEM during the past six months, has been completed. This was a particularly drastic type of failure in that it caused half or all SEM channels to become inoperative depending upon its location in the system. The failure was traced to a particular type of operational amplifier which, when malfunctioning, caused loss of a voltage supply within the SEM. The operational amplifier manufacturer acknowledged failure of his units and replaced defective ones at no charge to the project.

Array surficial maintenance consisted of subarray central area fence repairs, access roads, gate repairs, and sensor marker post replacements, at 11 subarrays.

4.2 Data Center

Equipment maintenance activity at LDC is summarized in Table XII. The entries for the IBM System/360 Model 44 computer were obtained from the GSA and IBM maintenance logs. This is a leased computer for which IBM provides the maintenance. Computer utilization for all LDC computers is presented in paragraph 5.1.1.

The largest number of 360/44 troubles occurred in the mainframe. However, this number includes two occurrences of disk trouble since the disk units are located within the mainframe. Apart from these troubles, the remainder are rather evenly distributed among the other IBM system components.

The PDP-7 magnetic tape units again accounted for nearly all of the PDP-7 troubles. However, component failure decreased and most troubles were corrected through adjustment. The adjustments involved head alignment and timing. The resulting down time due to tape unit problems decreased when compared with last quarter.

The analog recording system received attention again this quarter. Film for the Develocorders (16 mm film analog signal recorders) was received from a different manufacturer, and, although the recorded signal is satisfactory, the film is faster than that previously used and becomes fogged easier from light leaks. This is especially troublesome for the slow speed Develocorders which are used for recording the long-period seismometer signals. Other than careful handling no special action is now contemplated.

The perpetual difficulty with algae obstruction of the chemical drainage system of the Develocorder rack appears somewhat relieved since adopting a different product to flush algae growth into the drain. An ammonia product used in swimming pools is now being used to replace the chlorine bleach previously employed. This algae difficulty has always commanded attention and it is hoped that now some relief is in sight.

TABLE XII

DATA CENTER EQUIPMENT INCIDENCE OF REPAIR

Equipment	Number of Failures
PDP-7 Computers:	
Mainframes	2
Card reader	2
Typewriters	1
Magnetic tape units	48
360/44 Computer:	
Mainframe	7
Card punch/reader	1
Typewriter	2
Line printer	2
Magnetic tape units and controller	2
Data Adapters:	
IBM Model 1826	0
IBM Model 1827	1
IBM Model 2701	1
Analog System:	
Digital-to-analog system	1
Develocorders	1
Maintenance Console and Chart Recorders	4
Other	4
TOTAL	79

The defective chart recorder paper which caused problems throughout the last quarter (paragraph 4.2, reference 1) has been replaced by the manufacturer with a better grade of paper. Its performance is satisfactory.

SECTION V

OPERATION

The LDC operation continued as reported last quarter. The utilization of all LDC computers and a summary of the tape and film library operation is presented.

5.1 Data Center

Progress was made toward the fully operational IBM System 360/Model 44 LASAPS as reported in paragraph 2.1. However, until it does become operational the LDC operating procedures will remain as reported last quarter. Thus, this report summarizes that effort mostly performed with WAPS testing and the continuing seismic data analysis effort. Details regarding Computer Operation (5.1.1) and Library Operation (5.1.2) follow.

5.1.1 Computer Operation

The IBM System/360 Model 44 computer was used mainly for program development through August and early September. Starting 21 September 1968, the operation began on a 24-hour per day - 7-day per week schedule. The purpose was to test the LASA Processing Subsystem (LASAPS) during extended time runs. This testing was interrupted from time to time for purposes of additional program development, preventive, or corrective maintenance.

Table XIII shows the 360/44 computer utilization. Recording fully operational with WAPS and recording only at LASA increased during September and October while idle time decreased as activity with WAPS increased and because three shift operation began.

Table XIV, PDP-7 computer utilization, shows that off-line seismic signal processing decreased by approximately one hundred hours from last quarter as seismic activity returned to normal. The idle time is also down from last quarter as tape duplication increased. The USGS high explosive LASA calibration effort (paragraph 2.3.6) involved recording 32 extra tapes and duplicating an additional 61 tapes which contained events as reported in paragraph 2.3.6. An increased number of requests from Lincoln Laboratory and other users also contributed to the increase in the number of tapes duplicated. The introduction of the very low rate (VLR) format (paragraph 2.3.4) also contributed to the increase.

The recorded contents of the high-and low-rate tapes changed with the addition of equipment within the array. The very low rate tape recording was started on 1 August 1968. It contains microbarograph, weather station, and some long-period seismometer data as shown in Table XV, a reproduction of the VLR

TABLE XIII

SYSTEM/360 MODEL 44 COMPUTER UTILIZATION

Operation	Accumulated Time, Hours			
	Aug.	Sept.	Oct.	Total
On-line system program operation:				
Initial program loading	0.2	1.1	4.8	6.1
Recording with WAPS	0.0	129.4	389.7	519.1
Recording at LASA only	0.0	56.6	222.7	279.3
Other system operation:				
Data transmission from tape	0.0	0.5	0.0	0.5
Phone line testing	94.5	56.6	9.6	160.7
General use:				
Program development	287.8	66.6	73.5	427.9
Running utility programs	13.6	3.1	4.6	21.3
Down time:				
Scheduled maintenance	12.2	4.9	5.9	23.0
Corrective maintenance	8.4	12.8	15.6	36.8
Waiting for maintenance	0.2	0.1	0.7	1.0
Program halts and loops	0.0	3.4	7.8	11.2
Housekeeping	0.3	0.0	2.4	2.7
Idle time:				
With power on	71.7	130.9	2.3	204.9
With power off	243.2	229.6	0.0	472.8
Training	1.6	15.9	0.8	18.3
Running diagnostics	7.2	6.0	3.6	16.8
Reruns due to errors	3.1	2.5	0.0	5.6
Shut down, other than computer equipment inoperative	0.0	0.0	0.0	0.0
TOTALS	744.0	720.0	744.0	2208.0

TABLE XIV

PDP-7 COMPUTER UTILIZATION DURING AUGUST,
SEPTEMBER, AND OCTOBER 1968

Operation	PDP-7 Computer Hours		
	No.1	No.2	Total
On-line system program operation including:			
High Rate recording	0.6	0.0	0.6
Low Rate recording	1336.3	99.9	1436.2
High & Low Rate recording	697.2	56.5	753.7
Not recording operation	2.3	0.0	2.3
Program initialization	0.2	0.1	0.3
On-line calibration recording and system maintenance testing	0.3	0.0	0.3
Seismic data tape duplication and/or verification	19.4	322.2	341.6
Off-line seismic data reduction and analysis	50.0	692.2	742.2
General use including:			
Program development	3.4	97.9	101.3
Running utility programs	1.1	182.1	183.2
Computer down-time including:			
Scheduled maintenance	0.0	5.5	5.5
Corrective maintenance	3.5	6.6	10.1
Shut-down, computer equipment inoperative	5.1	22.4	27.5
System program stopped during cal-outs and program traps	7.8	0.9	8.7
Computer idle time	80.8	712.2	793.0
Training	0.0	5.3	5.3
Diagnostic programs and testing	0.0	3.7	3.7
Shut down, other than computer equipment inoperative	0.0	0.5	0.5
TOTAL	2208.0	2208.0	4416.0

TABLE XV

LASA VERY LOW RATE TABLE

Word		Site	Parameters
1			Time of Day
2			Time of Day
3	+ 35(K-1)	A0	Temperature
4	+ 35(K-1)	A0	Wind Direction
5	+ 35(K-1)	A0	Mbaro 7
6	+ 35(K-1)	A0	Wind Speed
7	+ 35(K-1)	F3	Mbaro
8	+ 35(K-1)	F4	Mbaro
9	+ 35(K-1)	A0	Mbaro 14
10	+ 35(K-1)	E4	Mbaro
11	+ 35(K-1)	E1	Mbaro
12	+ 35(K-1)	F1	Mbaro
13	+ 35(K-1)	E2	Mbaro
14	+ 35(K-1)	F2	Mbaro
15	+ 35(K-1)	A0	Barometer
16	+ 35(K-1)	B1	Mbaro
17	+ 35(K-1)	A0	Mbaro 18
18	+ 35(K-1)	B3	Mbaro
19	+ 35(K-1)	C4	Mbaro
20	+ 35(K-1)	B4	Mbaro
21	+ 35(K-1)	C1	Mbaro
22	+ 35(K-1)	C2	Mbaro
23	+ 35(K-1)	B2	Mbaro
24	+ 35(K-1)	C3	Mbaro
25	+ 35(K-1)	D3	Mbaro
26	+ 35(K-1)	D4	Mbaro
27	+ 35(K-1)	D1	Mbaro
28	+ 35(K-1)	D2	Mbaro
29	+ 35(K-1)	F3	LP-Z
30	+ 35(K-1)	F4	LP-Z
31	+ 35(K-1)	A0	LP-Z
32	+ 35(K-1)	E3	LP-Z
33	+ 35(K-1)	E4	LP-Z
34	+ 35(K-1)	E1	LP-Z
35	+ 35(K-1)	F1	LP-Z
36	+ 35(K-1)	E2	LP-Z
37	+ 35(K-1)	F2	LP-Z

The words for frame number one are shown.

Frame number = K = 1, 2, 120.

Sample rate = Two samples per second, all data.

table which is distributed similar to the high-and low-rate tables.

The low rate tape content changed three times this quarter as follows:

1. A barometer was added at Site A0.
2. The long-period seismic signals from Site C2 were attenuated by 30 dB.
3. The 30 dB attenuated center hole short-period seismic signals from A0, C2, F1, F2, F3, and F4 were added. To make room for these signals several microbarograph recording locations were changed. Also, E2 weather and the E3 beams were deleted.

The high rate tape content changed fifteen times this quarter as follows:

1. The 30 dB attenuated center hole short-period seismic signals were added (eleven changes).
2. The long-period seismic signals from Site C2 were attenuated by 30 dB (one change).
3. Weather stations were added to the array (three changes).

5.1.2 Library Operation

Operation of the LASA tape and film library continued as in the past, viz., for tape and film retention, duplication, and shipment. However, tape handling activity increased while film shipments remained normal. Statistics regarding tape and film handling and shipment appear in Tables XVI and XVII.

Library storage space was allotted for the very low rate recordings and copies of these tapes were shipped to the LASA Data Service for further distribution. Testing of the LASAPS (paragraph 2.1.1) also produced tapes for storage. Library space was allotted and upon being recorded these tapes are stored for six days and then reused in the system.

Tape shipments this quarter included 210 tapes to Harvard Computer Center. These tapes had accumulated at LASA over a period of time because they were either too short, contained bad spots and wouldn't record properly, were the cause of too many errors, etc. A utility program was written to speed the testing of the marginal tapes and to make a final quality

TABLE XVI
RECORDED MAGNETIC TAPE UTILIZATION

Application	Number of Tapes		
	Aug.	Sept.	Oct.
High rate tapes recorded and saved for 72 hours	1891	1901	1874
High rate tapes saved for 30 - 45 days	581	552	374
Low rate tapes recorded and saved for 90 days	578	550	573
LASAPS tapes recorded and saved for 6 days	0	168	513

TABLE XVII
LASA TAPE AND FILM SHIPMENTS

Destination	Reels of Mag. Tape	Reels of Film
Lincoln Laboratory	556	0
LASA Data Service	278	338
Seismic Data Laboratory	35	0
IBM	99	0
Harvard Computer Laboratory	210	0
Destroyed	0	0
TOTAL	1178	338

judgment. Shipping of these tapes helped relieve the LASA tape storage problem. The tapes recorded for the USGS test (paragraph 2.3.6) were sent to the LASA Data Service for further distribution.

BLANK PAGE

APPENDIX A

LASAPS BACKUP SYSTEM HIGH RATE TAPE FORMAT

The following is a description of the LASAPS high rate recording format, originally provided by Group 64 of the Massachusetts Institute of Technology Lincoln Laboratory, but now modified for the LASAPS backup system.

A. Definitions

Data Word

One sample of data from one source at a subarray, usually a single seismometer sample. Sources (seismometers) will be identified D_{ij} where "i" is the subarray identity and $1 \leq i \leq 21$, where "j" is the detector identity within a subarray and $1 \leq j \leq 31$. Data words will appear (within the computer and on tape) in the following format, assuming two's complement representation:

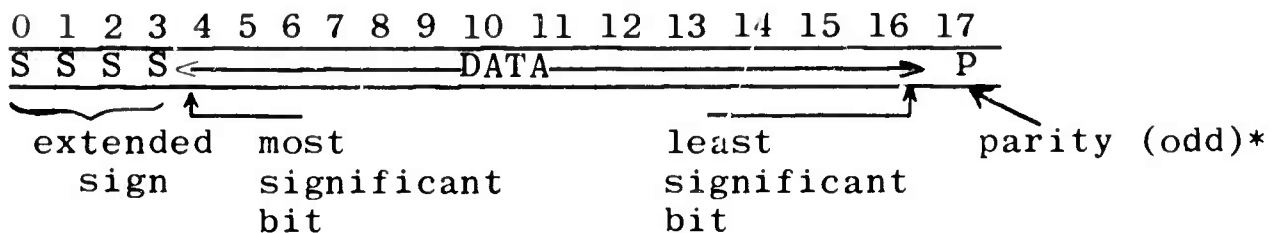

Word Group

Twenty-one data words, one from each subarray, arriving "simultaneously" at array terminal (within 1.5 ms).

Frame

Equal to 31 word groups. All the data for a single fifty millisecond sample period, i.e., one sample from each seismometer.

Frame = (21 subarrays) (31 data words = 651 data words).

* Parity is computed for bits 3 to 16 only.

Header

Auxiliary data to be recorded on tape with each record, and including time, data, record identification, etc.

Trailer

Auxiliary data to be recorded on tape with an occasional record and including status of each detector, status of each subarray, etc. (The fact that a trailer is included will be noted by a bit in the header.)

Record

Will include two frames plus one header, and occasionally plus one trailer.

B. Formats

Tape Format:

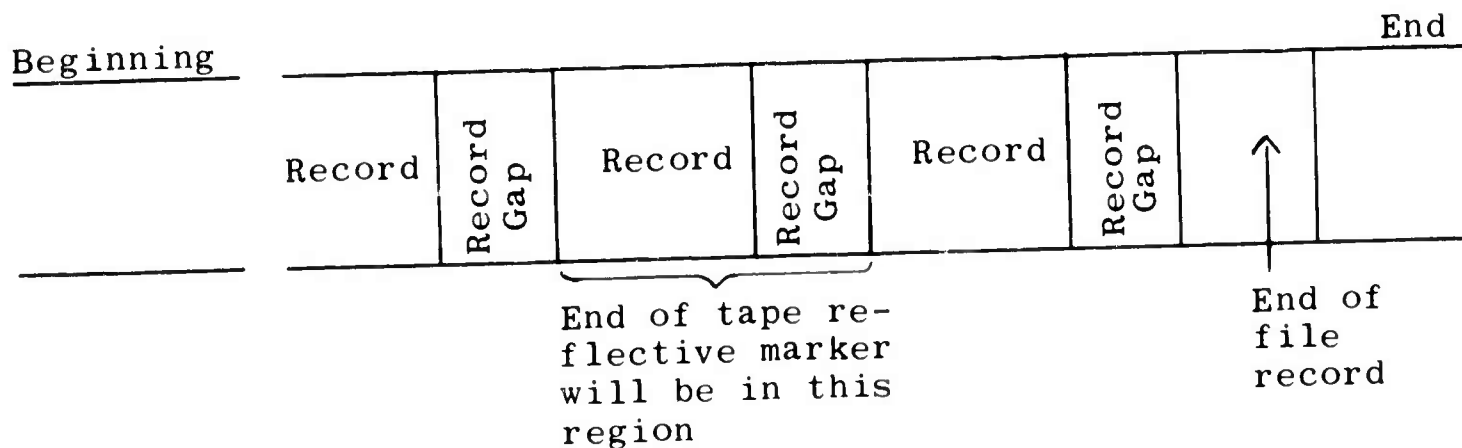

Record Format:

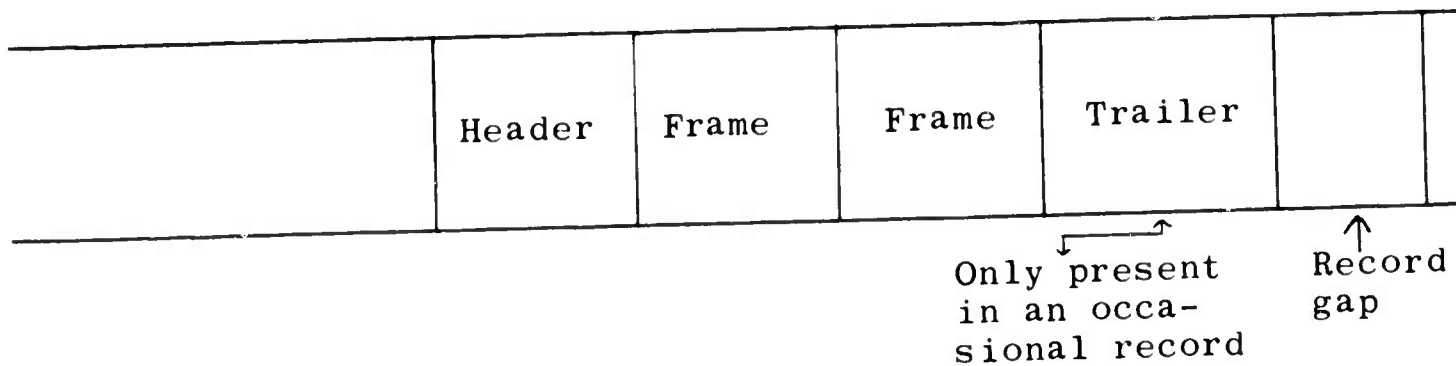

Header Format:

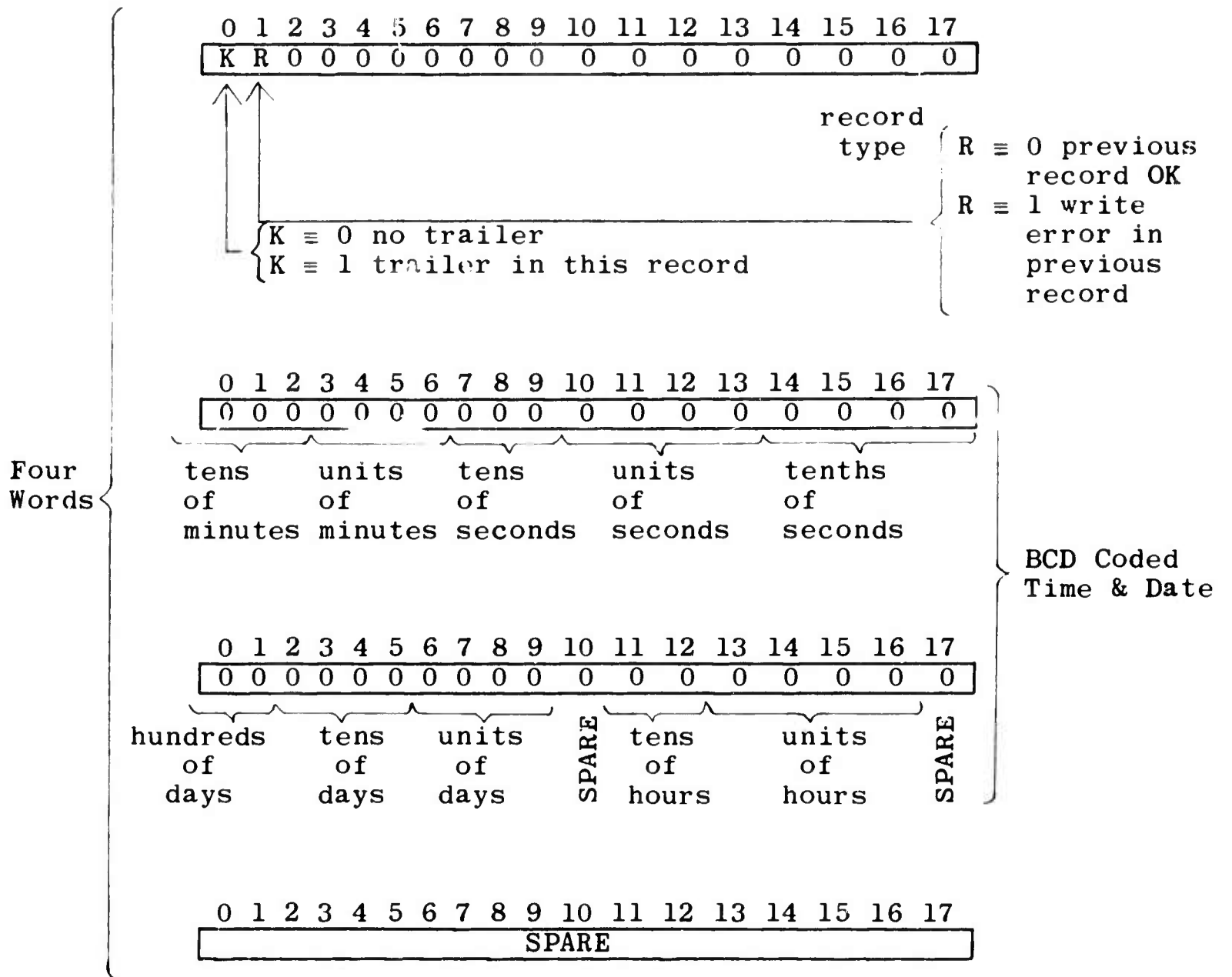

Frame Format:

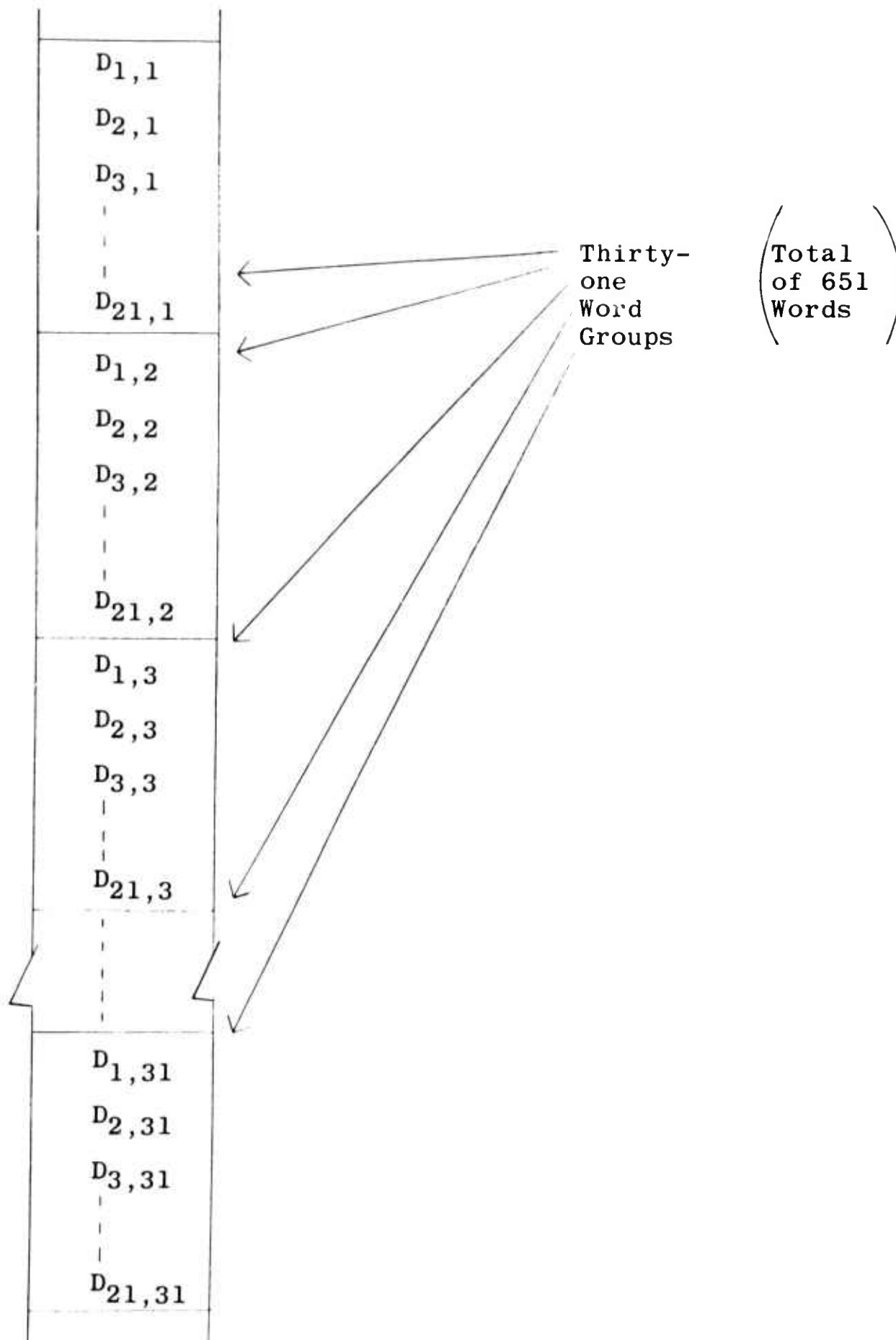

Trailer Format:

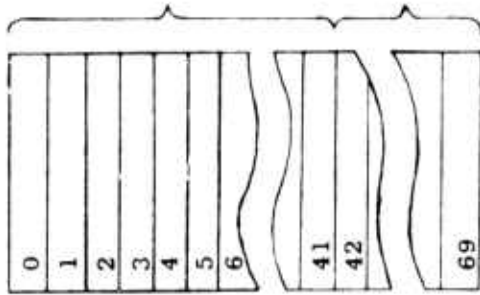

42 Words in 21 groups of two words each,
giving status of each subarray and
seismometer

28 Spare words

Example of Status for Subarray B3

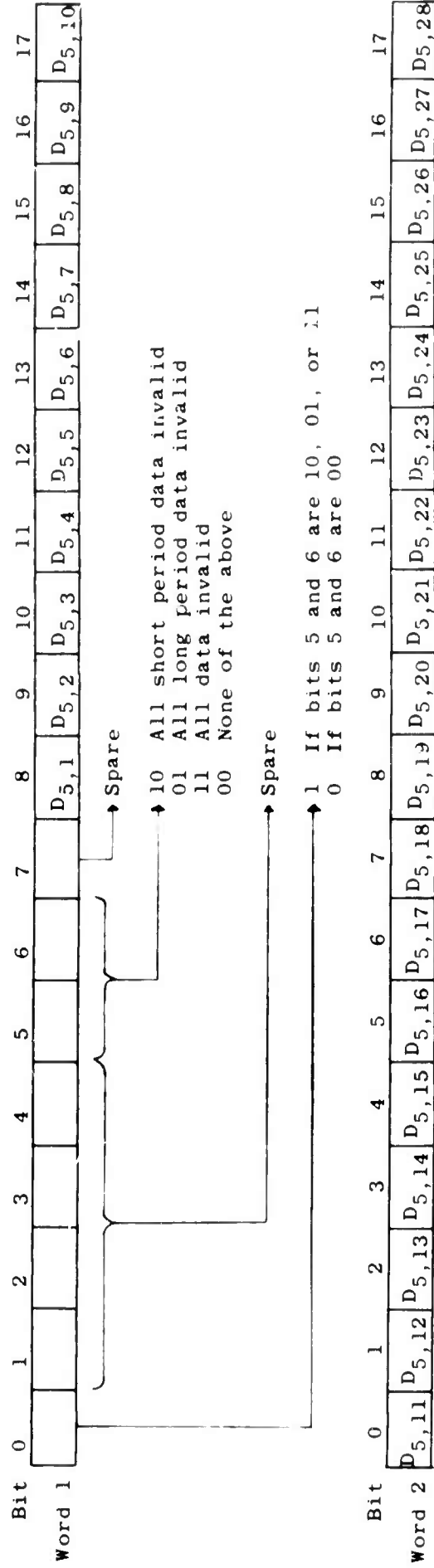

REFERENCES

1. "First Quarterly Technical Report, Montana Large Aperture Seismic Array," ESD-TR-68-316, August 1968, by Philco-Ford Corporation, Billings, Montana.
2. "Montana LASA Annual Report, 1 June 1966 through 30 June 1967," A-001-22, by Philco-Ford Corporation, Billings, Montana.
3. "Montana LASA Annual Report, 1 July 1967 through 30 April 1968," A-001-30, by Philco-Ford Corporation, Billings, Montana.
4. "IISPS - General System Specifications, Reference 1," IBM SAAC, Washington, D.C.
5. "Noise-Reducing Line Microphone for Frequencies Below 1CPS," by Fred B. Daniels, The Journal of the Acoustical Society of America, Volume 31, Number 4, Page 529, April 1959.
6. "Travel-Time Anomalies of LASA," by D. E. Frankowski, and F. A. Klappenberger, Report Number LL-6, Earth Sciences Division, Teledyne Industries, 7 July 1967.
7. "Seismometer Evaluation Procedure Short-Period Vertical Seismometer," by M. J. Lemelin, Philco-Ford Corporation, E&TS Division, Report Number M-500-1, 9 May 1967.

UNCLASSIFIED

Security Classification

DOCUMENT CONTROL DATA - R & D

(Security classification of title, body of abstract and indexing annotation must be entered when the overall report is classified)

1. ORIGINATING ACTIVITY (Corporate author) Philco-Ford Corporation, E & TS Division 214 North 30th Billings, Montana 59103		2a. REPORT SECURITY CLASSIFICATION UNCLASSIFIED	
		2b. GROUP N/A	
3. REPORT TITLE MONTANA LARGE APERTURE SEISMIC ARRAY			
4. DESCRIPTIVE NOTES (Type of report and inclusive dates) Second Quarterly Technical Report, 1 August 1968 through 31 October 1968			
5. AUTHOR(S) (First name, middle initial, last name) None			
6. REPORT DATE November 1968		7a. TOTAL NO. OF PAGES 104	7b. NO. OF REFS 7
8a. CONTRACT OR GRANT NO. F19628-68-C-0401		9a. ORIGINATOR'S REPORT NUMBER(S) ESD-TR-68-428	
b. PROJECT NO.		9b. OTHER REPORT NO(S) (Any other numbers that may be assigned this report)	
c.			
d.			
10. DISTRIBUTION STATEMENT This document is subject to special export controls and each transmittal to foreign governments or foreign nationals may be made only with prior approval of Hq ARPA (TIO).			
11. SUPPLEMENTARY NOTES		12. SPONSORING MILITARY ACTIVITY Directorate of Planning and Technology, Electronic Systems Division, AFSC, USAF, L G Hanscom Field, Bedford, Mass. 01730	
13. ABSTRACT This report concerns technical activity at the Montana Large Aperture Seismic Array(LASA). IBM System/360 Model 44 computer programming to complete the Montana segment of the Interim Integrated Signal Processing System (IISPS) and system testing are discussed. Array work described includes installation of attenuated short-period and long-period seismic signal channels and completion of the Large Aperture Microbarograph Array (LAMA). A report on the experiment which utilized the LASA for early warning of the occurrence of potentially destructive earthquakes concludes that the reaction time for reporting large event parameters is on the order of one-half hour and that currently employed LASA data analysis techniques are adequate. A report on oil well drilling noise confirms preliminary conclusions which state that no effect on LASA data analysis from analog sum signals is evident unless drilling occurs within about two miles of the center hole sensor. Measured short-period seismic channel phase shift statistics are reported. Also provided are statistics on the seismic events reported in the Seismo Bulletin, maintenance of the equipment, and general operation of the Data Center.			

UNCLASSIFIED

Security Classification

14. KEY WORDS	LINK A		LINK B		LINK C	
	ROLE	WT	ROLE	WT	ROLE	WT
LASA - Large Aperture Seismic Array LAMA - Large Aperture Microbarograph Array Seismic Array Seismic Signal Processing Seismic Research Seismic Noise Seismic Observatory Operation Microbarograph Array						

UNCLASSIFIED

Security Classification