

UNCLASSIFIED

AD NUMBER
AD846267
NEW LIMITATION CHANGE
TO Approved for public release, distribution unlimited
FROM Distribution authorized to U.S. Gov't. agencies and their contractors; Administrative/Operational Use; DEC 1968. Other requests shall be referred to US Army Biological Laboratory, Attn: SMUFD Technical Release Branch TID, Fort Detrick, MD 21701.
AUTHORITY
BORL, d/a, ltr, 29 Sep 1971

THIS PAGE IS UNCLASSIFIED

AD

AD846267

TECHNICAL MANUSCRIPT 483

THE CLINICAL ASPECTS
OF RIFT VALLEY FEVER VIRUS
IN HOUSEHOLD PETS:
I. SUSCEPTIBILITY OF THE DOG

Norman S. Remmele
Jerry S. Walker
Richard C. Carter
John Q. Mitten
Leonard G. Schuh
Edward L. Stephen
Frederick Klein

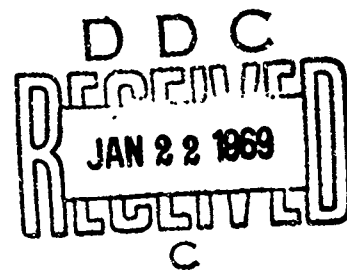

DECEMBER 1968

STATEMENT #2 UNCLASSIFIED

This document is subject to special export controls and each transmittal to foreign governments or foreign nationals may be made only with prior approval of Dept. of Army, Fort Detrick, ATTN: Technical Release Branch/TID, Frederick, Maryland 21701

ACCESSION BY	
NOV 1950	WHITE SECTION <input type="checkbox"/>
	DEFENSE SECTION <input checked="" type="checkbox"/>
UNCLASSIFIED	
JUSTIFICATION	
BY	
DISTRIBUTION/AVAILABILITY CODES	
DIST.	AVAIL. and/or SPECIAL
2	

Reproduction of this publication in whole or in part is prohibited except with permission of the Commanding Officer, Fort Detrick, ATTN: Technical Releases Branch, Technical Information Division, Fort Detrick, Frederick, Maryland, 21701. However, DDC is authorized to reproduce the publication for United States Government purposes.

DDC AVAILABILITY NOTICES

Qualified requesters may obtain copies of this publication from DDC.

Foreign announcement and dissemination of this publication by DDC is not authorized.

Release or announcement to the public is not authorized.

DISPOSITION INSTRUCTIONS

Destroy this publication when it is no longer needed. Do not return it to the originator.

The findings in this publication are not to be construed as an official Department of the Army position, unless so designated by other authorized documents.

DEPARTMENT OF THE ARMY
Fort Detrick
Frederick, Maryland 21701

TECHNICAL MANUSCRIPT 483

THE CLINICAL ASPECTS OF RIFT VALLEY FEVER VIRUS IN
HOUSEHOLD PETS: I. SUSCEPTIBILITY OF THE DOG

Norman S. Remmele
Jerry S. Walker
Richard C. Carter
John Q. Mitten
Leonard G. Schuh
Edward L. Stephen
Frederick Klein

Process Development Division
AGENT DEVELOPMENT AND ENGINEERING LABORATORIES

Project 1B533001D426

December 1968

In conducting the research described in this report, the investigators adhered to the "Guide for Laboratory Animal Facilities and Care," as promulgated by the Committee on the Guide for Laboratory Animal Facilities and Care of the Institute of Laboratory Animal Resources, National Academy of Sciences-National Research Council.

ABSTRACT

The dog was shown to be susceptible to Rift Valley fever virus (RVFV). Death occurred in all animals of 1 and 7 days of age inoculated with $1 \times 10^{2.2}$ MICLD₅₀ or more of virus, and two of four puppies died following inoculation with $1 \times 10^{0.2}$ MICLD₅₀ of virus. Temperature at death was hypothermic. Older animals, although susceptible, were not killed by RVFV; there were no signs of clinical illness, although 50% of adult dogs developed a viremia. All animals with a positive viremia demonstrated a positive serum neutralization titer. Transmission of RVFV from pup to mother and from pup to pup was demonstrated. There was evidence that antibodies were passed from mother to pup in the colostrum. The data suggest an effect on fertility. The epidemiological aspects of this study are discussed.

CONTENTS

Abstract 2

I. INTRODUCTION 5

II. MATERIALS AND METHODS 5

 A. Animals and Their Conditioning 5

 B. Experimental Studies 6

 C. Inoculum 6

 D. Assay Procedures 6

 E. Sampling and Monitoring Techniques 8

 F. Serum Neutralization Test 8

 G. Postmortem 8

III. RESULTS 9

 A. Dose-Response Curves 9

 B. Transmission of RVFV Between Individuals 13

 C. Manifestation of RVFV Infection 14

IV. DISCUSSION 18

 Literature Cited 23

 Distribution List 25

 DD Form 1473 27

FIGURES

1. Experimental Design for the Study of Rift Valley Fever Virus in
Dogs 7

2. Dose Response of 1-Day-Old and 1-Week-Old Puppies to Rift
Valley Fever Virus 12

TABLES

1. Response of 1-Day-Old Pups to RVFV (Study 1) 10

2. Response of 7-, 14-, and 21-Day-Old Pups to RVFV (Studies 2,
3, and 4) 11

3. Response of 42-Day-Old Pups to RVFV (Study 5) 12

4. Response of 7-Day-Old Pups from Two Immune Bitches (Study 8) . . . 13

5. Response of Dogs to Exposure by Direct Animal Contact. 14

6. Response of 84-Day-Old Puppies and Adults to RVFV (Studies 6 and 7). 16

7. Response of Pregnant Bitches to Challenge with RVFV (Study 9) . . . 17

8. Reproductive Results of Bitches One Year from Inoculation with
RVFV 19

9. Summary of Responses of Different Age Dogs to Inoculation with
RVFV 20

I. INTRODUCTION

Rift Valley fever (RVF) is an acute viral disease primarily of sheep, cattle, and humans. The mortality is very low in adult cattle, about 50% in calves and adult sheep, and about 100% in lambs.¹ Although the morbidity in susceptible humans is very high, mortality is 0% unless complicated by secondary infection.

The disease in animals is characterized by a short incubation period, febrile response, and a very high mortality in susceptible animals. Human infections due to laboratory accidents have occurred in England, Japan, and the United States. The disease in humans is characterized by an "influenza-like" syndrome^{2,3} with fever, chills, headache, malaise, and generalized muscle pain. The onset is sudden and the course short (4 to 7 days); however, complete recovery sometimes may take weeks.

Reported animal outbreaks so far have been confined to the African continent, primarily to the Rift Valley area of Kenya.¹ As with an exotic disease, although confined to a particular area or continent, the possibility always exists of outbreaks in any country by exposure to asymptomatic carriers or vectors of the virus.

The Randall vaccine⁴ has proven highly immunogenic and effective in protecting individuals from laboratory infections,⁵ but it is possible that man can be an asymptomatic carrier capable of transmitting the disease to a susceptible species, e.g. sheep or cattle, or through household pets such as dogs and cats. In the absence of specific information concerning this possibility, newborn suckling puppies, adult dogs, and dogs of intermediate age were tested for their susceptibility to Rift Valley fever virus (RVFV). The possibility that the dog is an asymptomatic carrier and is capable of transmitting the disease was also tested.

II. MATERIALS AND METHODS

A. ANIMALS AND THEIR CONDITIONING

The dogs used in these studies were purebred beagles purchased from commercial breeders of laboratory dogs. Pregnant bitches were purchased, and the 1-, 7-, 14-, and 21-day-old puppies were born in the laboratory so that the exact age of the litters was known at time of challenge. The 42-day-old litters were purchased with puppies still nursing. Approximately 30 days before shipment, all animals 84 days old or older were vaccinated by the supplier for canine hepatitis, leptospirosis, and rabies. The only exceptions to this rule were the 84-day-old puppies, which were vaccinated 7 days before shipment.

B. EXPERIMENTAL STUDIES

The experimental design is presented in Figure 1. The results reported herein are divided into three major areas of work utilizing the pregnant bitches, their pups and other adult dogs to accumulate data. The first of these major studies was designed to provide information on the dose-response relationship of different age dogs to RVFV (studies 1 to 7). Adults and bitches with litters of 1-, 7-, 14-, 21-, 42-, and 84-day-old pups were used for these studies. Pups were inoculated by the subcutaneous route with 0.5 ml amounts of virus at concentrations of 0.2, 2.2, 4.2, 6.2, or 8.2 \log_{10} MICLD₅₀. Ten litters containing a total of 53 pups and six adult dogs were included.

The second major study was designed to provide information on the transmission of the virus by an asymptomatic host known to have a viremia; i.e., (i) horizontal transmission (pup to pup; studies 1-C, 2, 4, 5-K), (ii) ascending transmission (pup to bitch; studies 1-A, 1-C, 1-D, 2, 3, 4, 5-K), and (iii) descending transmission (bitch to pup; study 1-B).

The final phase of this work included certain supplemental studies concerned with the clinical manifestation of RVFV in infected dogs. All dogs (inoculated and uninoculated) were observed for alterations of body temperature, antibody response, and virus replication in the blood. In several of these dogs, studies were conducted on the transfer of passive immunity to RVFV via the colostrum (study 8), along with the possibility of abortion as a result of RVFV infection (study 9).

C. INOCULUM

The van Wyk strain⁶ of RVFV was used for virus inoculation and serum neutralization studies. The virus was propagated in a monolayer tissue culture system utilizing a permanent mouse cell line grown in medium 199 peptone plus 10% calf serum.

D. ASSAY PROCEDURES

The mice used for titration of viremias and serum neutralization tests were the Fort Detrick strain Swiss-Webster. They were of mixed sex and weighed 10 to 12 g. All mouse inoculations were made intracerebrally employing 0.03 ml of material after appropriate dilutions in Hanks balanced salt solution (60%) plus medium 199 peptone (30%) plus calf serum (10%) at pH 7.8. Eight mice were used for each dilution of the assay. The Spearman and Karber⁷ method of calculating mouse intracranial lethal dose (\log_{10} MICLD₅₀) was used.

The viremias were determined on whole heparinized (1,000 USP units/ml of Na heparin, Upjohn) blood diluted at 10^{-1} , 10^{-2} , and 10^{-3} .

STUDIES

DOGS PURCHASED PREGNANT BITCHES

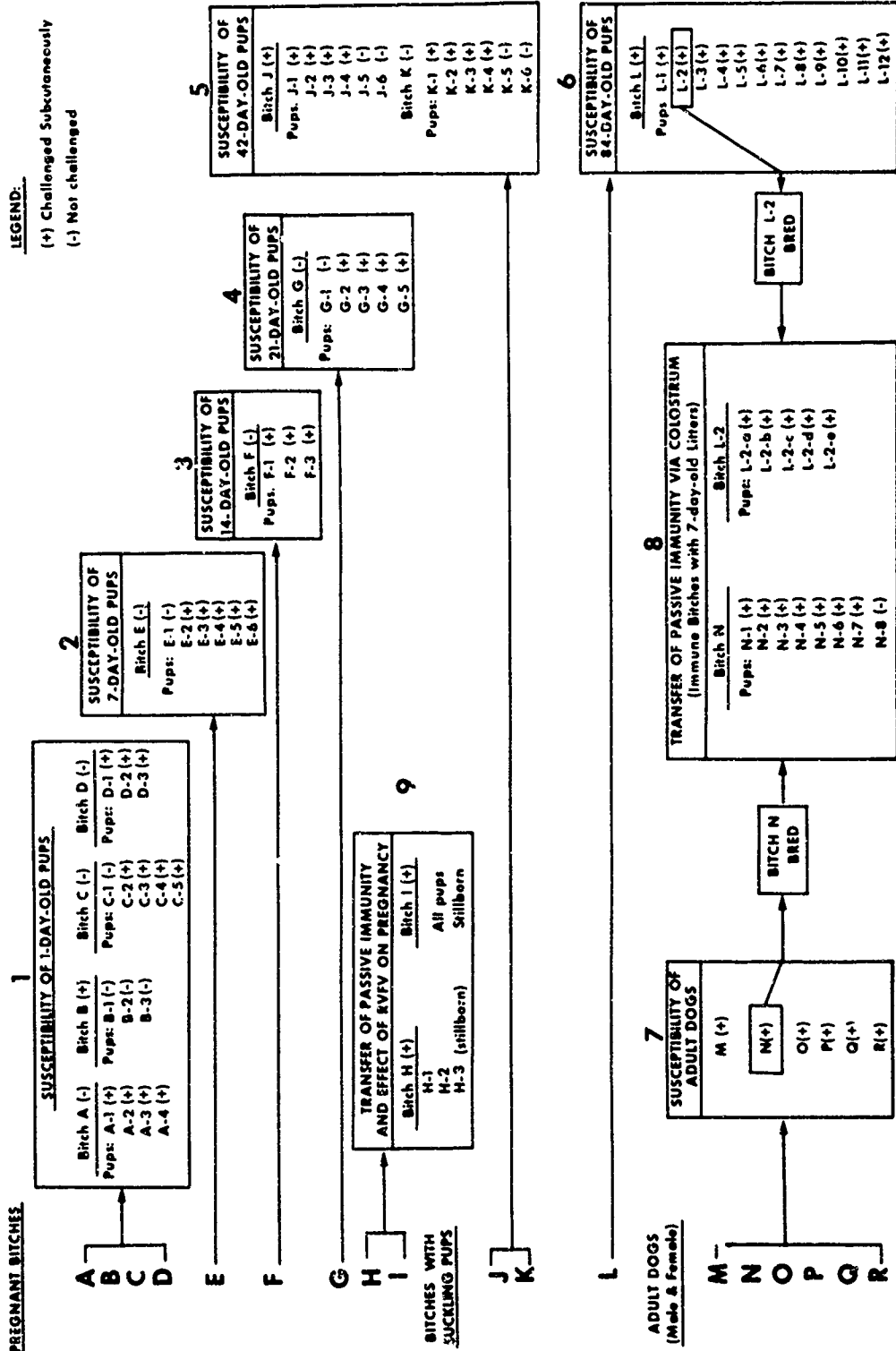

FIGURE 1. Experimental Design for the Study of Rift Valley Fever Virus in Dogs. Major studies included the susceptibility of dogs of various ages to infection with RVFV (studies 1 to 7) and determination of virus transmission among inoculated and uninoculated animals. Supplemental studies included: (i) observations for alterations of body temperature, antibody response, and virus replication in the blood, (ii) transfer of passive immunity to RVFV via the colostrum (study 8), and (iii) possibility of abortion as a result of RVFV infection (study 9).

E. SAMPLING AND MONITORING TECHNIQUES

Pre- and postinoculation blood samples were drawn in 10- to 20-ml quantities depending on age and size of the dog. The blood was allowed to clot, and the serum was decanted for serum neutralization titers.

Up to 10 days postinoculation, the temperature of each dog was taken rectally, and clinical observations were made every 24 hours unless the animal showed signs of illness; then monitoring was increased to twice a day. Time-to-death was recorded morning and evening. Postinoculation blood samples were taken at least twice during the first 7 days to determine if and to what degree a viremia was present.

F. SERUM NEUTRALIZATION TEST

Blood samples (20 ml) for serum neutralization were drawn 28 days postinoculation and, in some cases, at 21 days postinoculation. Serum was inactivated by heat at 56 C for 30 minutes, then serum neutralizing antibody was measured by mixing equal portions of undiluted inactivated serum with equal volumes of serial 10-fold dilutions of virus produced in a tissue culture medium. The inactivated serum-virus mixture was held in a water bath at 37 C for 1 hour before inoculation in mice. The log serum neutralization index (LSNI) was the difference between the MICLD₅₀ of virus in the presence of a known negative serum and the test serum. A known negative and a known positive serum were always used during each assay as a negative and positive control. The LSNI was considered positive in all cases where the index value was 1.0 or greater.

G. POSTMORTEM

All dogs that survived infection were sacrificed at 30 days post-inoculation and complete autopsies were performed. The results of these observations are available separately.*

* Mitten, J.Q., personal communication.

III. RESULTS

A. DOSE-RESPONSE CURVES

Only pups of 1 and of 7 days age died after inoculation with RVFV (Tables 1 and 2). Death occurred in all animals inoculated with $10^{2.2}$ or greater MICLD₅₀ of virus, and two of four pups inoculated with only $10^{0.2}$ MICLD₅₀ of virus died. Older pups and adults, although infected, were not killed by this virus (Tables 2 and 3).

The general relationship between dose and time-to-death is presented in Figure 2. A positive correlation between increased dose of virus and shorter time-to-death was apparent; also, it was apparent from the statistically lower slope ($P < 0.01$) of the dose-response curves for 7-day-old pups compared with 1-day-old pups that the resistance of 7-day-old pups was increasing rapidly. This conclusion was consistent with the increased resistance of 21-day-old and older dogs as indicated by their survival after inoculation.

Seven-day-old pups from two litters born of immunized bitches were resistant to inoculation for all doses of virus through $10^{8.2}$ MICLD₅₀ (Table 4). Resistance in this case was passive and is discussed later.

In an attempt to characterize the clinical response of the dog to RVFV infection, daily temperatures of all animals were recorded. The temperature response of 1- and 7-day-old pups during the course of infection was hypothermic or low normal. Only six of 14 pups were hyperthermic at any time, and all died in a hypothermic state, some with body temperatures as low as 91 F. The temperature responses of 21-, 42-, and 84-day-old pups and of adult animals remained in the normal range and without drastic temperature fluctuation in any case.

Until 18 to 24 hours before death, when most puppies became comatose, no clinical signs of illness were expressed. Two 1-day-old pups and one 7-day-old pup showed some degree of central nervous system involvement as evidenced by ataxia, paddling, and opisthotonos. The pathological data support these clinical findings.

TABLE 1. RESPONSE OF 1-DAY-OLD PUPS TO RVFV (STUDY 1)

Animal Identification	Inoculated Dose, log ₁₀ MICLD ₅₀	Viremia _g /Day Postinoculation								LSNI _b /Day Postinoculation		
		1	2	3	4	5	6	7	8	0	21	28
BITCH A	0	-c/	-	Neg ^d /	Neg	-	-	Neg	-	Neg	1.0	1.25
Pups: A-1	8.2	De/	-	-	-	-	-	-	-	-	-	-
A-2	8.2	D	-	-	-	-	-	-	-	-	-	-
A-3	6.2	-	3.52	-	Neg	D	-	-	-	-	-	-
A-4	6.2	-	D	-	-	-	-	-	-	-	-	-
BITCH B	8.2	3.52	2.65	Neg	Neg	-	Neg	Neg	Neg	Neg	2.25	1.63
Pups: B-1	0	-	-	Neg	-	-	-	-	-	-	Neg	Neg
B-2	0	-	-	Neg	-	-	-	-	-	-	Neg	Neg
B-3	0	-	-	Neg	-	-	-	-	-	-	Neg	Neg
BITCH C	0	-	-	Neg	-	Neg	-	Neg	-	Neg	Neg	Neg
Pups: C-1	0	-	-	Neg	-	3.52	-	-	-	-	1.50	1.36
C-2	4.2	-	-	D	-	-	-	-	-	-	-	-
C-3	2.2	-	-	4.77	-	Neg	-	D	-	-	-	-
C-4	2.2	-	-	4.77	-	Neg	-	D	-	-	-	-
C-5	0.2	-	-	Neg	-	4.65	-	Neg	D	-	-	-
BITCH D	0	-	-	Neg	-	-	-	Neg	-	Neg	1.19	1.56
Pups: D-1	0.2	-	-	Neg	-	Neg	-	Neg	-	Neg	Neg	Neg
D-2	0.2	-	-	Neg	-	Neg	-	Neg	-	Neg	Neg	Neg
D-3	0.2	-	-	Neg	-	Neg	-	Neg	D	Neg	Neg	Neg

a. Log₁₀ MICLD₅₀ per ml of blood.

b. Log serum neutralization index.

c. - = not done.

d. Negative at a 10-1 dilution of the blood.

e. D = dead.

TABLE 2. RESPONSE OF 7-, 14-, AND 21-DAY-OLD PUPS TO RVFV (STUDIES 2, 3, AND 4)

Age of Pups, days	Animal Identification	Inoculated Dose, log ₁₀ MICLD ₅₀	Viremia ^a / Day Postinoculation								LSNLD ^b / Day Postinoculation		
			1	2	3	4	5	6	7	8	0	21	28
7	BITCH E	0	-	-	Neg ^c / -	-	-	-	-	-	Neg	2.25d/ -	2.57
	Pups: E-1	0	-	-	Neg	-	-	-	-	-	-	1.25e/ -	2.64
	E-2	8.2	-	-	4.65	-	-	-	-	-	-	3.40f/ -	-
	E-3	8.2	-	-	4.65	-	-	-	-	-	-	4.02f/ -	-
	E-4	4.2	-	-	4.40	-	-	-	-	-	-	3.15f/ -	-
	E-5	4.2	-	-	2.65	-	-	-	-	-	-	3.20f/ -	-
	E-6	2.2	-	-	4.90	-	-	-	-	-	Neg	Dead	-
14	BITCH F	0	-	-	Neg	-	-	-	-	-	Neg	Neg	Neg
	Pups: F-1	8.2	3.90	3.40g/ -	-	-	-	-	-	-	-	-	-
	F-2	8.2	3.40	3.15	Neg	Neg ^g / -	-	-	-	-	-	-	-
	F-3	8.2	4.27	Neg	-	-	-	-	-	-	-	-	-
21	BITCH G	0	-	-	Neg	-	-	-	-	-	Neg	Neg	Neg
	Pups: G-1	0	-	-	Neg	-	-	-	-	-	-	-	-
	G-2	8.2	3.52	2.77	Neg	2.65	-	-	-	-	-	-	-
	G-3	6.2	Neg	2.90	2.77	-	-	-	-	-	-	-	-
	G-4	4.2	Neg	3.52	3.15	-	-	-	-	-	-	-	-
	G-5	2.2	Neg	3.27	Neg	-	-	-	-	-	-	-	-

a. Log₁₀ MICLD₅₀ per ml of blood.
 b. Log serum neutralization index.
 c. Negative at 10⁻¹ dilution of the blood.
 d. Also positive on 14th day at 1.88.
 e. Also positive on 14th day at 1.38.
 f. Died same day.
 g. Animal sacrificed.

TABLE 3. RESPONSE OF 42-DAY-OLD PUPS TO RVFV (STUDY 5)

Animal Identification	Inoculated Dose, \log_{10} MICLD ₅₀	Viremia/ Day Postinoculation						LSNID/ Day Postinoculation	
		2	3	4	5	6	7	0	28
BITCH J	8.2	Neg ^c	Neg	1.51	-	-	Neg	Neg	2.55
Pups: J-1	8.2	2.82	3.19	-	-	-	Neg	-	2.96
J-2	8.2	0.76	Neg	-	-	-	3.19	-	3.41
J-3	6.2	Neg	Neg	-	-	-	Neg	-	3.18
J-4	6.2	Neg	Neg	-	-	-	Neg	-	2.67
J-5	0	Neg	Neg	-	-	-	Neg	-	Neg
J-6	0	Neg	Neg	-	-	-	Neg	-	Neg
BITCH K	0	Neg	3.14	-	3.51	-	4.51	Neg	2.37
Pups: K-1	8.2	3.35	2.89	-	-	-	2.82	-	2.98
K-2	8.2	3.11	Neg	-	-	-	Neg	-	3.17
K-3	4.2	Neg	2.84	-	-	-	2.94	-	2.34
K-4	4.2	3.14	3.01	-	-	-	Neg	-	3.26
K-5	0	Neg	Neg	-	-	-	Neg	-	Neg
K-6	0	Neg	Neg	-	-	-	Neg	-	2.46

- a. \log_{10} MICLD₅₀ per ml of blood.
 b. Log serum neutralization index.
 c. Negative at 10^{-1} dilution of the blood.

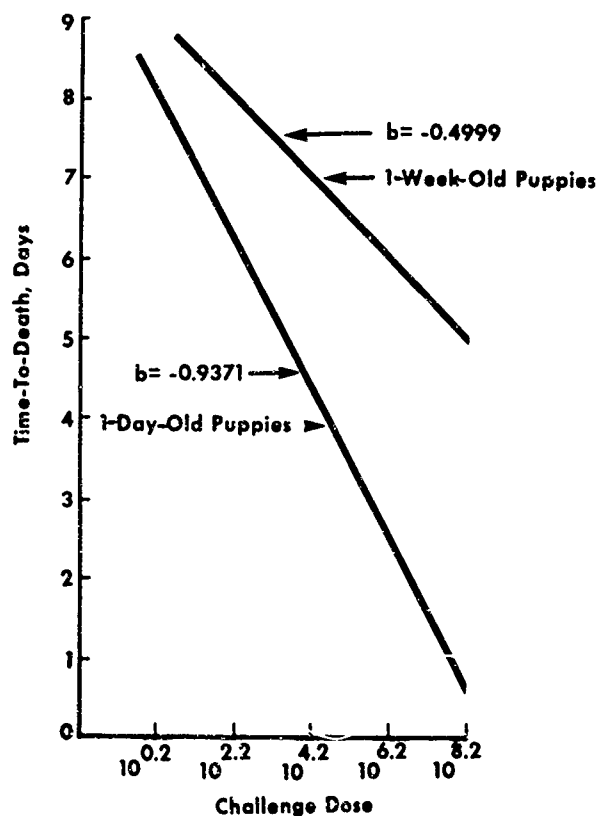

FIGURE 2. Dose Response of 1-Day-Old and 1-Week-Old Puppies to Rift Valley Fever Virus.

TABLE 4. RESPONSE OF 7-DAY-OLD PUPS FROM TWO IMMUNE BITCHES (STUDY 8)

Animal Identification	Inoculated Dose, \log_{10} MICLD ₅₀	LSNI ^a / Day Postinoculation	
		0 ^b	28
Bitch N	0	2.13	2.50
Pups: N-1	8.2	-	1.45
N-2	8.2	-	1.38
N-3	6.2	-	2.10
N-4	6.2	-	1.75
N-5	6.2	-	1.63
N-6	4.2	-	1.00
N-7	4.2	-	1.00
N-8	0	-	Neg ^c
Bitch L-2	0	3.00	2.50
Pups: L-1-a	8.2	-	1.50
L-2-b	8.2	-	1.94
L-3-c	8.2	-	1.28
L-4-d	8.2	-	1.86
L-5-e	8.2	-	1.50

- Log serum neutralization index.
- For the two bitches, zero day was 4 months from their initial inoculation. All pups were negative for viremia at 5 and 7 days postinoculation.
- Negative at 10^{-1} dilution of the blood.

B. TRANSMISSION OF RVFV BETWEEN INDIVIDUALS

A total of 19 animals were exposed only by contact with infected animals, as summarized in Table 5. Ascending transmission occurred in six of eight cases. In one case, the bitch developed a viremia following inoculation of the pups (Table 3, Bitch K). We were unable to demonstrate descending transmission in the one case tested (Table 1, Bitch B). Horizontal transmission was demonstrated in three of eight uninoculated pups. One pup (Table 1, Bitch C, pup C-1) developed both a viremia and LSNI, and two pups (Table 2, Bitch E, pup E-1 and Table 3, Bitch K, pup K-6) developed only LSNI.

TABLE 5. RESPONSE OF DOGS TO EXPOSURE
BY DIRECT ANIMAL CONTACT

Method and Age of Dog	Number of Animals	Number Having a Viremia ^a /	Number Showing a Positive LSNI ^b /
Descending transmission			
Bitch to 1-day-old puppies	3	0	0
Ascending transmission			
Pups to Bitches	8	1	6
Horizontal transmission			
Pup to pup 1-day-old pups	1	1	1
7-day-old pups	2	0	1
21-day-old pups	1	0	0
42-day-old pups	4	0	1
Total of all attempts	19	2	9

a. Viremia = >10 MICLD₅₀ per ml of blood.

b. LSNI = log serum neutralization index >1.0 .

C. MANIFESTATION OF RVFV INFECTION

1. Viremia

Of the 11 inoculated 1-day-old pups, three were negative when tested for viremia, four were positive with viremias between $10^{3.5}$ and $10^{4.8}$ MICLD₅₀/ml of blood, and, in addition, four animals died before viremia titer was determined (Table 1). The data on responses of 7-, 14-, and 21-day-old pups (Table 2) show that all inoculated pups of Bitch E (7-day-old) developed a viremia and died. All the 14-day-old pups from Bitch F were sacrificed for pathological studies on days 2, 4, and 6 postinoculation; however, each of these three pups developed a viremia on days 1 and 2. Even with inoculated doses as low as $10^{2.2}$ MICLD₅₀ of virus, all four inoculated pups (Table 2, Bitch G) developed viremias on the 2nd day, and viremia persisted in two animals through the 7th day postinoculation.

Older puppies did not succumb to infection, but developed viremias (Table 3). Six of eight inoculated pups (42-day-old) had viremias at least one time between the 2nd and 7th day; however, all eight animals became infected as evidenced by LSNI at 28 days postinoculation.

Eighty-four-day-old pups and adult dogs displayed the same pattern (Table 6) as the 42-day-old pups. Seven of the 12 inoculated 84-day-old pups developed viremias, and all 12 were infected because they developed positive LSNI by 28 days postinoculation. Of the 18 adult dogs used in the study, 11 were challenged directly with doses ranging from 4.2 to 8.2 \log_{10} MICLD₅₀ per ml. Of these 11, six (55%) developed viremias, and 10 (91%) developed positive LSNI. The single animal (Bitch I) considered LSNI-negative was one of the six adults that developed viremias, showing 2.75 \log_{10} MICLD₅₀ per ml of blood on the 3rd day postinoculation. Thus, the data indicate that the rate of infection among adult dogs challenged directly was essentially 100%.

2. Serum Neutralization Tests

All inoculated animals that developed a positive viremia and survived had a positive LSNI. In addition, inoculated animals that did not develop a viremia developed a positive LSNI on testing at 21 and/or 28 days, indicating subclinical infections that resulted in immunological responses. Finally, nine of 19 uninoculated animals showed a positive LSNI. Only three of these nine animals had developed a viremia (Table 5). The data are inadequate to determine whether the LSNI is affected by (i) age of animal at inoculation, (ii) inoculated dose, or (iii) the observation of a viremia; however, the 28-day titers tend to be higher than the 21-day titers.

3. Passive Immunity via Colostrum

Two bitches that survived inoculation (Bitch L-2, study 6 and Bitch N, study 7) were kept for breeding in order to infect their puppies at various ages. The degree and duration of passive immunity derived from the colostrum could then be recorded as the relationship among age, time-to-death, and dose.

It was shown that maternal antibody, as determined by LSNI, was passed via the colostrum to pup. Two pregnant bitches (H and I, Table 7) challenged with a high dose of RVFV aborted their puppies. All of Bitch I's puppies were stillborn. One of three of Bitch H's puppies was stillborn; the other two were LSNI-negative at birth and LSNI-positive after 24 hours.

TABLE 6. RESPONSE OF 84-DAY-OLD PUPPIES AND ADULTS TO RVFV (STUDIES 6 AND 7)

Age of Dog, days	Animal Identification	Inoculated Dose, log ₁₀ MICLD ₅₀	Viremia/Day Postinoculation					LSNB/Day Postinoculation		
			2	3	4	5	6	7	0	28
84	Bitch L	8.2	Neg ^c	Neg	-	Neg	-	Neg	Neg	2.46
	Pups: L-1	8.2	Neg	2.85	-	Neg	-	Neg	Neg	>2.67
	L-2	8.2	4.51	3.68	-	Neg	-	2.71	Neg	>2.67
	L-3	8.2	3.14	Neg	-	Neg	-	Neg	Neg	>2.67
	L-4	8.2	Neg	Neg	-	Neg	-	Neg	Neg	>2.67
	L-5	6.2	Neg	Neg	-	Neg	-	Neg	Neg	>2.67
	L-6	6.2	Neg	3.14	-	Neg	-	2.82	Neg	>2.67
	L-7	6.2	Neg	Neg	-	Neg	-	Neg	Neg	>2.67
	L-8	6.2	Neg	Neg	-	Neg	-	Neg	Neg	>2.67
	L-9	4.2	1.51	Neg	-	Neg	-	Neg	Neg	>2.67
	L-10	4.2	Neg	Neg	-	Neg	-	2.68	Neg	>2.67
	L-11	4.2	Neg	3.39	-	Neg	-	4.19	Neg	>2.67
L-12	4.2	Neg	Neg	-	Neg	-	Neg	Neg	>2.67	
Adult	M	8.2	-	Neg	Neg	Neg	Neg	Neg	Neg	>2.67
	N	8.2	-	2.68	Neg	2.51	Neg	Neg	Neg	>2.67
	O	6.2	-	Neg	2.84	Neg	Neg	2.68	Neg	>2.67
	P	6.2	-	Neg	Neg	Neg	Neg	Neg	Neg	>2.67
	Q	4.2	-	Neg	Neg	Neg	Neg	Neg	Neg	>2.67
	R	4.2	-	Neg	Neg	Neg	Neg	Neg	Neg	>2.67

a. Log₁₀ MICLD₅₀ per ml of blood.

b. Log serum neutralization index.

c. Negative at 10⁻¹ dilution of the blood.

TABLE 7. RESPONSE OF PREGNANT BITCHES TO CHALLENGE WITH RVFV (STUDY 9)

Animal Identi- fication	Inoculated Dose, log ₁₀ MICLD ₅₀	Viremia ^a / Day Postinoculation			LSNI ^b / Day Postinoculation	
		3	5	7	0	28
Bitch H ^c /	8.2	3.35	Neg	Neg	Neg	1.37
					Pup at birth	Neg
					Pup at 24 hours	1.12
Bitch I ^d /	8.2	2.75	Neg	Neg	Neg	1.0

- a. Log₁₀ MICLD₅₀ per ml of blood.
b. Log serum neutralization index.
c. At 21 days postinoculation, whelped a litter of three puppies, of which one was stillborn.
d. Aborted all puppies stillborn on the 13th day postinoculation, which was 5 days before the expected whelping date.

The fact that maternal antibody is passed in the colostrum led to a study in which the two adult bitches (N and L-2, study 8) that had survived the infection, and were demonstrating a positive LSNI, were bred. The puppies were inoculated with virus when 7 days old. Table 4 gives the results. None of the inoculated puppies succumbed to the infection, nor did they develop viremias at either 5 or 7 days post-inoculation. Both of these observations are in direct contrast to results obtained with 1-week-old puppies from a nonimmune bitch (Table 2, Bitch E, study 2), and suggest passive protection afforded by maternal antibody being transferred via colostrum. The data obtained from the two puppies of bitch H (Table 7) also support this contention. Of interest is the observation that puppy N-7, which was not inoculated, was negative for serum neutralization at 28 days postinoculation or 5 weeks after whelping.

4. Effect of RVFV on Fertility

Two parous bitches whose litters were aborted, had the following history. Bitch K (Table 3) was subsequently rebred and whelped a full-term litter of six puppies 5 months after challenge of her first litter; three were stillborn and three died within 24 hours. Her LSNI was negative 1 day after whelping, 2.12 at 7 days after whelping, and 2.37 at 28 days postinoculation. Bitch R (Table 6) aborted on the 48th day of pregnancy. Her LSNI was >2.67 at 28 days postinoculation, 2.25 at 1 day after abortion, and >4.5 at 4 weeks after abortion. One bitch

(L-10, Table 6) which had been inoculated at 84 days, conceived after breeding as determined by palpation and reabsorbed her fetuses during the 2nd trimester of pregnancy. Serum neutralization studies were not done on her during or after pregnancy. These observations led us to examine the reproductive data on bitches that were bred 1 year after challenge with RVFV. The data (Table 8) show that under our conditions (i) the estrus cycle was abnormal in that prolonged anestrus was exhibited, (ii) the fertility of the bitches was impaired, and (iii) the parturition rate as determined by live litters was abnormally low.

IV. DISCUSSION

The susceptibility of most species to RVFV is in question because of the limited number of animals inoculated in controlled laboratory experiments. The most extensive work to date is that of Easterday, Murphy, and co-workers,⁸⁻¹⁰ working mainly with lambs, goats, and calves. They point out that their data on sheep are still incomplete and should be extended.⁹ Easterday,¹ following Findlay's classification, attempted in his review to classify species on the basis of their susceptibility to RVFV. He lists the dog as not being susceptible to the RVFV. The presently reported data summarized in Table 9 show that the canine species is susceptible, and by using Easterday's classification,¹ puppies younger than 3 weeks of age would be 4+ (100% or nearly 100% fatal) while older animals would be 1+ or possible ± as virus may survive for a time in blood but usually without causing a reaction. It appears from Easterday's data¹ and ours that an accurate classification of species susceptibility cannot be determined without extensive laboratory testing at various doses and ages.

Animal-to-animal transmission was successful. The unsuccessful attempts by others using various species are summarized by Easterday.¹ The authors feel that, in view of the reports in the literature^{8,9-17} on attempted isolations from animals, the most likely route of transmission in these studies is by urine (mother licking and cleaning pups) or by saliva (pups playing with mouth to mouth contact, or by injuring nipples of mother while nursing).

It was also of interest that approximately 50% of 84-day-old puppies and adults developed viremias, and these viremias extended in some cases over a 4- to 5-day period at levels of approximately 10^3 MICLD₅₀ per ml of blood without any significant clinical responses. Because the animals were sampled only twice in 8 days, it is probable that, in many, viremias were not detected. It is believed that, if adult animals were sampled on a 4- to 8-hour basis from time of inoculation through 10 days post-inoculation, practically 100% of the animals would show viremias of several days' duration.

TABLE 8. REPRODUCTIVE RESULTS OF BITCHES ONE YEAR FROM INOCULATION WITH RVFV

Age	Number of Animals	Estrus Cycle		Conception		Live Litters	
		Actual	Expected ^a	Actual	Expected ^a	Actual	Expected ^a
Nulliparous bitches	5	2	5	1	3	1	3
Parous bitches	6	4	6	4	6	1	6
Total	11	6	11	5	9	2	9

a. The expected values were obtained from animal breeders and by personal communication with animal breeders.

TABLE 9. SUMMARY OF RESPONSES OF DIFFERENT AGE DOGS TO INOCULATION WITH RVFV

Age, days	Number of		Positive Viremia ^a		Deaths	Positive LSN ^b /	Easterday's Classification of Susceptibility ^c /
	Animals	Number	%	71e/			
1	11	5d/	71e/	9E/	0		4+
7	5	5	100	5	0		4+
21	4	4	100	0	4		1+
42	8	6	75	0	8		1+
84	12	7	58	0	12		1+
Adult	10	4	40	0	10		1+

a. Viremia titer of 10 MICLD₅₀ or greater per ml of blood.

b. Positive LSNⁱ is log serum neutralization index of >1.0.

c. Susceptibility groupings as reviewed by Easterday.¹

d. Four puppies died before blood was sampled for viremia (see litters A and C, Table 1).

e. Based on the seven living animals sampled. Note also that the two negative animals

received only 100.2 MICLD₅₀ (see litter D, Table 1).

f. Two surviving puppies received 100.2 MICLD₅₀.

Easterday⁸ maintains that "how and where the disease is maintained" is unknown in most cases. RVFV is known to be an arbovirus capable of being transmitted by almost any mosquito, yet the "reservoir" host has never been clearly identified.¹ Capstick and Gosden¹⁸ suggested that adult sheep might serve in this capacity. The present authors suggest that the canine species be considered for the role of reservoir host and carrier of RVFV in the Rift Valley of Africa. The above premise is based on the following reasons: (i) the disease is primarily of sheep and goats and the dog is used extensively in the herding of these species, (ii) the dog is capable of viremic levels sufficient to infect mosquitoes, (iii) the dog, except for the very young, shows no clinical illness while infected, and, finally, (iv) the dog, being a very close companion of man, not only could account for some human infections, but also mosquito transmission to other species. The authors realize that much work remains to prove the statements above, but feel it is reasonable to suggest the dog as a reservoir host for RVFV based on the results presented here. More work needs to be done on the mode of animal-to-animal transmission, for this is of particular interest when evaluating the role of the canine species in the dissemination of RVFV. Direct excretion of infective virus would imply a carrier as well as a reservoir state.

LITERATURE CITED

1. Easterday, B.C. 1965. Rift Valley fever. *Advances Vet. Sci.* 10:65-127.
2. Kitchen, S.F. 1934. Laboratory infections with the virus of Rift Valley fever. *Amer. J. Trop. Med.* 14:547-564.
3. Schwentker, F.F.; Rivers, T.M. 1934. Rift Valley fever and Rift Valley rodents. *East African Med. J.* 36:665-667.
4. Randall, R.; Binn, L.M.; Harrison, V.R. 1963. Rift Valley fever virus vaccine. *Amer. J. Trop. Med. Hyg.* 12:611-615.
5. Murphy, L.C.; Easterday, B.C. 1961. Rift Valley fever: A zoonosis, p. 397-412. 65th Annu. Proc. United States Livestock Sanitary Ass.
6. Kaschula, V.R. 1953. The propagation and modification of strains of Rift Valley fever viruses in embryonated eggs and their use as immunizing agents for domestic ruminants. Thesis, Doctor of Veterinary Science, University of Pretoria, South Africa.
7. Finney, D.J. 1952. Statistical methods in biological assay, p. 524-530. Hafner Publishing Company, New York.
8. Easterday, B.C.; Murphy, L.C. 1963. Studies of Rift Valley fever in laboratory animals. *Cornell Vet.* 53:423-433.
9. Easterday, B.C.; Murphy, L.C.; Bennett, D.G., Jr. 1962. Experimental Rift Valley fever in lambs and sheep. *Amer. J. Vet. Res.* 23:1231-1240.
10. Easterday, B.C.; Murphy, L.C.; Bennett, D.G., Jr. 1962. Experimental Rift Valley fever in calves, goats, and pigs. *Amer. J. Vet. Res.* 23:1224-1230.
11. Daubney, R.; Hudson, J.R.; Garnham, P.C. 1931. Enzootic hepatitis or Rift Valley fever: An undescribed virus disease of sheep, cattle, and man from East Africa. *J. Pathol. Bacteriol.* 34:545-579.
12. Easterday, B.C.; McGavran, M.H.; Rooney, J.R.; Murphy, L.C. 1962. The pathogenesis of Rift Valley fever in lambs. *Amer. J. Vet. Res.* 23:470-479.
13. Kaschula, V.R. 1957. Rift Valley fever as a veterinary and medical problem. *J. Amer. Vet. Med. Ass.* 131:219-221.
14. McGavran, M.H.; Easterday, B.C. 1963. Rift Valley fever virus hepatitis: Light and electron microscopic studies in the mouse. *Amer. J. Pathol.* 42:587-607.

15. Mims, C.A.C. 1957. Rift Valley fever in mice: VI. Histological changes in the liver in relation to virus multiplication. Australian. J. Exp. Biol. Med. Sci. 35:595-604.
16. Mims, C.A.C. 1956. Rift Valley fever virus in mice: I. General features of the infection. Brit. J. Exp. Pathol. 37:99-109.
17. Weiss, K.E. 1957. Rift Valley fever: A review. Bull. Epizootic Dis. Africa 5:431-458.
18. Capstick, P.B.; Gosden, D. 1962. Neutralizing antibody response of sheep to pantropic and neurotropic Rift Valley fever virus. Nature 195:583-584.

Security Classification

DOCUMENT CONTROL DATA - R & D		
<i>(Security classification of title, body of abstract and indexing annotation must be entered when the overall report is classified)</i>		
1. ORIGINATING ACTIVITY (Corporate author)		2a. REPORT SECURITY CLASSIFICATION
Department of the Army Fort Detrick, Frederick, Maryland, 21701		Unclassified
		2b. GROUP
3. REPORT TITLE		
THE CLINICAL ASPECTS OF RIFT VALLEY FEVER VIRUS IN HOUSEHOLD PETS: I. SUSCEPTIBILITY OF THE DOG		
4. DESCRIPTIVE NOTES (Type of report and inclusive dates)		
5. AUTHOR(S) (First name, middle initial, last name)		
Norman S. Remmele John Q. Mitten Frederick (NMI) Klein Jerry S. Walker Leonard G. Schuh Richard C. Carter Edward L. Stephen		
6. REPORT DATE	7a. TOTAL NO. OF PAGES	7b. NO. OF REFS
December 1968	27	18
8a. CONTRACT OR GRANT NO.		8b. ORIGINATOR'S REPORT NUMBER(S)
a. PROJECT NO. 1B533001D426		Technical Manuscript 483
c.		9a. OTHER REPORT NO(S) (Any other numbers that may be assigned this report)
d.		
10. DISTRIBUTION STATEMENT		
Qualified requesters may obtain copies of this publication from DDC. Foreign announcement and dissemination of this publication by DDC is not authorized. Release or announcement to the public is not authorized.		
11. SUPPLEMENTARY NOTES		12. SPONSORING MILITARY ACTIVITY
		Department of the Army Fort Detrick, Frederick, Maryland, 21701
13. ABSTRACT		
The dog was shown to be susceptible to Rift Valley fever virus (RVFV). Death occurred in all animals of 1 and 7 days of age inoculated with $1 \times 10^{2.2}$ MICLD ₅₀ or more of virus, and two of four puppies died following inoculation with $1 \times 10^{0.2}$ MICLD ₅₀ of virus. Temperature at death was hypothermic. Older animals, although susceptible, were not killed by RVFV; there were no signs of clinical illness, although 50% of adult dogs developed a viremia. All animals with a positive viremia demonstrated a positive serum neutralization titer. Transmission of RVFV from pup to mother and from pup to pup was demonstrated. There was evidence that antibodies were passed from mother to pup in the colostrum. The data suggest an effect on fertility. The epidemiological aspects of this study are discussed.		
14. Key Words		
*Rift Valley fever virus *Dogs *Host Susceptibility		

DD FORM 1473

REPLACES DD FORM 1473, 1 JAN 64, WHICH IS OBSOLETE FOR ARMY USE.

Unclassified

Security Classification