

UNCLASSIFIED

AD NUMBER

AD846695

LIMITATION CHANGES

TO:

Approved for public release; distribution is unlimited.

FROM:

Distribution authorized to U.S. Gov't. agencies and their contractors; Critical Technology; JAN 1969. Other requests shall be referred to Air Force Flight Dynamics Laboratory, Wright-Patterson AFB, OH 45433. This document contains export-controlled technical data.

AUTHORITY

AFFDL ltr, 21 Oct 1971

THIS PAGE IS UNCLASSIFIED

cy'

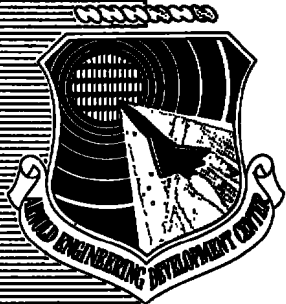

**AERODYNAMIC CHARACTERISTICS OF
SUPERSONIC X PARACHUTES AT
MACH NUMBERS OF 2.1 AND 4.0**

Lawrence L. Galigher

ARO, Inc.

This document is approved for public release
its distribution is unlimited. *PER TAB 72-21 11/26
Dtd 20 Dec 74*

January 1969

DISTRIBUTION LIMITED TO U. S. GOV'T AGENCIES
ONLY, Test and Evaluation; 12 Nov. 71. Other
requests for this document must be referred
to Director, Air Force Flight Dynamics Lab.,
Attn: FDFR. Wright-Patterson AFB,
Ohio 45433.
PER TAB 72-21, dated 1 November, 1972.

**PROPULSION WIND TUNNEL FACILITY
ARNOLD ENGINEERING DEVELOPMENT CENTER
AIR FORCE SYSTEMS COMMAND
ARNOLD AIR FORCE STATION, TENNESSEE**



NOTICES

When U. S. Government drawings specifications, or other data are used for any purpose other than a definitely related Government procurement operation, the Government thereby incurs no responsibility nor any obligation whatsoever, and the fact that the Government may have formulated, furnished, or in any way supplied the said drawings, specifications, or other data, is not to be regarded by implication or otherwise, or in any manner licensing the holder or any other person or corporation, or conveying any rights or permission to manufacture, use, or sell any patented invention that may in any way be related thereto.

Qualified users may obtain copies of this report from the Defense Documentation Center.

References to named commercial products in this report are not to be considered in any sense as an endorsement of the product by the United States Air Force or the Government.

AERODYNAMIC CHARACTERISTICS OF
SUPERSONIC X PARACHUTES AT
MACH NUMBERS OF 2.1 AND 4.0

Lawrence L. Galigher
ARO, Inc.

This document is subject to special export controls and each transmittal to foreign governments or foreign nationals may be made only with prior approval of AFFDL (FDFR) Wright-Patterson AFB, Ohio 45433.

DISTRIBUTION LIMITED TO U. S. GOV'T AGENCIES ONLY; Test and Evaluation; 12 Nov 71. Other requests for this document must be referred to Director, Air Force Flight Dynamics Lab., Attn: FDFR. Wright-Patterson AFB, Ohio 45433.

PER TAB 72-21, dated 1 November, 1972.

This document has been approved for public release
its distribution is unlimited.

PER TAB 74-26, 74
20 Dec, 74

FOREWORD

The work reported herein was done at the request of the Air Force Flight Dynamics Laboratory (AFFDL), Air Force Systems Command (AFSC), under Program Element 62201F, Project 6065, Task 606505.

The results of tests presented were obtained by ARO, Inc. (a subsidiary of Sverdrup & Parcel and Associates, Inc.), contract operator of the Arnold Engineering Development Center (AEDC), AFSC, Arnold Air Force Station, Tennessee, under Contract F40600-69-C-0001. The test was conducted from October 24 to 30, 1968, under ARO Project No. PS0927 and the manuscript was submitted for publication on December 2, 1968.

Information in this report is embargoed under the Department of State International Traffic in Arms Regulations. This report may be released to foreign governments by departments or agencies of the U. S. Government subject to approval of AFFDL (FDFR), Wright-Patterson AFB, Ohio 45433, or higher authority within the Department of the Air Force. Private individuals or firms require a Department of State export license.

This technical report has been reviewed and is approved.

Richard W. Bradley
Lt Col, USAF
AF Representative, PWT
Directorate of Test

Roy R. Croy Jr.
Colonel, USAF
Director of Test

ABSTRACT

A test was conducted in the Propulsion Wind Tunnel, Supersonic (16S), to determine deployment characteristics and aerodynamic performance of Supersonic X parachutes having geometric porosities of 13.4, 26.0, and 59.2 percent. Deployments were made from a cylindrical forebody having a flared aft section at free-stream Mach numbers of 2.1 and 4.0 at a nominal free-stream dynamic pressure of 80 psf. All of the parachutes tested failed shortly after deployment, and no data were obtained at Mach numbers other than the deployment Mach numbers.

This document is subject to special export controls and each transmittal to foreign governments or foreign nationals may be made only with prior approval of AFFDL (FDFR), Wright-Patterson AFB, Ohio 45433.

This document has been approved for public release
its distribution is unlimited. *PER 1773 7426*
DT 20 Dec, 74

CONTENTS

	<u>Page</u>
ABSTRACT.	iii
NOMENCLATURE.	vi
I. INTRODUCTION	1
II. APPARATUS	
2.1 Test Facility.	1
2.2 Test Articles.	2
2.3 Instrumentation.	3
III. PROCEDURE.	3
IV. RESULTS AND DISCUSSION	
4.1 Parachute Dynamic Characteristics.	4
4.2 Parachute Steady-State Performance	4
V. CONCLUDING REMARKS	5

APPENDIXES

I. ILLUSTRATIONS

Figure

1. Model Location in Test Section	9
2. Dimensioned Sketch of Model Forebody	10
3. Installation of Model Forebody in Test Section	11
4. Sketch of Model Forebody Showing Load Cell Installation	12
5. Parachute Installation in Model Forebody	13
6. Dimensioned Sketch of the Supersonic X Parachute	14
7. Gore Dimensions of the Supersonic X Parachutes	15
8. Parachute Deployment Characteristics	
a. Supersonic X-2 Parachute, $M_\infty = 4.0$	16
b. Supersonic X-3 Parachute, $M_\infty = 4.0$	16
c. Supersonic X-4 Parachute, $M_\infty = 2.1$	17
d. Backup Supersonic X-4 Parachute, $M_\infty = 2.1$	17

<u>Figure</u>	<u>Page</u>	
9.	Distribution Plots of Parachute Drag Coefficient	
	a. Supersonic X-2 Parachute, $M_\infty = 4.0$	18
	b. Supersonic X-3 Parachute, $M_\infty = 4.0$	19
	c. Supersonic X-4 Parachute, $M_\infty = 2.1$	20
	d. Backup Supersonic X-4 Parachute, $M_\infty = 2.1$	21
10.	Variation of Parachute Drag Coefficient with Mach Number	22
II.	STATISTICAL ANALYSIS PROGRAM	23
III.	TABLE	
	I. Summary of Parachute Statistical Analysis Results	26

NOMENCLATURE

C_{Dp}	Average drag coefficient of parachute based on design projected canopy area, drag force/ $q_\infty S_p$
C_{Dpi}	Mean parachute drag coefficient value of each cell in the statistical analysis program, drag force/ $q_\infty S_p$
M_∞	Free-stream Mach number
N	Total number of drag coefficient data samples used in the statistical analysis program
N_i	Number of drag coefficient data samples in each cell of the statistical analysis program
$(N_i)_{max}$	Maximum number of drag coefficient data samples in any cell of the statistical analysis program
q_∞	Free-stream dynamic pressure, psf
S_p	Design projected area of inflated parachute canopy, 9.6214 ft ²
$\sqrt{\beta_1}$	Skewness parameter of a distribution of drag coefficient data obtained from the statistical analysis program
β_2	Kurtosis parameter of a distribution of drag coefficient data obtained from the statistical analysis program
σ	Standard deviation of a distribution of drag coefficient data obtained from the statistical analysis program

SECTION I INTRODUCTION

Supersonic aerodynamic decelerators are scheduled for rocket-powered free-flight and captive sled development tests by the National Aeronautics and Space Administration (NASA), Langley Research Center and the AFFDL, respectively, to determine optimum decelerator configurations for specific decelerator system application. Prior knowledge of the effect of various decelerator design parameters on the performance characteristics of various decelerator types would provide the data necessary to limit the selection of decelerators to be investigated in free-flight and captive sled development tests. The effect of various design parameters on the performance characteristics of three types of decelerators will be investigated in a three-phase test program conducted in Tunnel 16S of the Propulsion Wind Tunnel Facility at Mach numbers from 2.0 to 4.5. The purpose of Phase I tests, reported herein, was to determine deployment characteristics and aerodynamic performance of Supersonic X parachutes having geometric porosities of 13.4, 26.0, and 59.2 percent. The parachutes were deployed at Mach numbers of 2.1 and 4.0 at a nominal free-stream dynamic pressure of 80 psf. The purpose of Phase II tests will be to determine performance characteristics of Disc-Gap-Band parachutes and towed ballutes. The purpose of Phase III tests will be to determine performance characteristics of attached inflatable decelerators.

SECTION II APPARATUS

2.1 TEST FACILITY

Tunnel 16S is a closed-circuit, continuous flow wind tunnel that presently can be operated at Mach numbers from 1.70 to 4.75. The tunnel can be operated over a stagnation pressure range from 200 to approximately 2300 psfa. The test section stagnation temperature can be controlled through the range of 100 to approximately 620°F. The tunnel specific humidity is controlled by removing tunnel air and supplying conditioned makeup air from an atmospheric dryer.

A sketch showing the model location and strut support arrangement in Tunnel 16S is presented in Fig. 1, Appendix I. A more complete

description of the wind tunnel and its operating characteristics is contained in the Test Facilities Handbook.¹

2.2 TEST ARTICLES

2.2.1 Model Forebody and Deployment System

The parachutes tested during this investigation were deployed from a strut-mounted cylindrical forebody having a flared aft section. Dimensions of the forebody are presented in Fig. 2, and a wind tunnel installation photograph of the model is shown in Fig. 3.

The parachute pack was placed in the forebody stowage compartment against a spring-loaded plate. Four restraining straps, connected together by a release pin, were used to hold the parachute pack against the spring-loaded plate. The parachute riser line was affixed to the forebody through a swivel and load cell arrangement. A shear pin, designed to protect the load cell, connected the riser line to the swivel. The purpose of the swivel was to prevent twisting of the parachute suspension lines. A sketch showing the model forebody details and the attachment of the riser line to the forebody is presented in Fig. 4, and a photograph of the forebody with a stowed parachute pack is shown in Fig. 5. Also shown in Fig. 5 is the pyrotechnic release pin mechanism that was used to initiate parachute deployment.

2.2.2 Parachute Details

A dimensioned sketch of the Supersonic X parachute is presented in Fig. 6, and the cloth gore dimensions of the Supersonic X-2, X-3, and X-4 parachutes tested are presented in Fig. 7 in tabular form. The parachutes were constructed of a relatively nonporous cloth with a single exit opening that controlled the airflow through the canopy. The parachutes had a maximum projected diameter of 3.5 ft and were located 9.428 ft aft of the forebody base plane. The geometric porosities, based on the canopy entrance and exit areas, of the Supersonic X-2, X-3, and X-4 parachutes were 13.4, 26.0 and 59.2 percent, respectively.

¹Test Facilities Handbook (7th Edition). "Propulsion Wind Tunnel Facility, Vol. 5." Arnold Engineering Development Center, July 1968.

2.3 INSTRUMENTATION

A 5000-lb_f capacity, double-element load cell, installed in the model forebody, was used to measure the drag force of the parachutes within an accuracy of $\pm 10_f$. Four motion-picture cameras and two television cameras, installed in the test section walls, were used to document and monitor the test.

The outputs from the load cell were digitized and code punched on paper tape for on-line data reduction and were recorded on magnetic tape by a high-speed digital recording system at a sampling rate of 1000 per second for off-line data reduction. These outputs were also continuously recorded on direct-writing and film pack oscillographs for monitoring parachute drag dynamics.

SECTION III PROCEDURE

The parachute pack, which consisted of a parachute enclosed in a deployment bag, was packed in the forebody stowage compartment before wind tunnel test operation was initiated. Once the prescribed test conditions were established, a countdown procedure was used to sequence data acquisition during parachute deployment. The deployment procedure consisted of activating the recording oscillographs, test section cameras, and the high-speed digital recording system, followed by firing a pyrotechnic squib in the release pin mechanism. Upon completion of the parachute deployment sequence, steady-state drag loads were calculated by averaging the analog outputs from the load cell over 1-sec intervals. Drag distribution parameters, such as average drag coefficient, standard deviation, skewness, and kurtosis, of the dynamic drag data recorded by the high-speed digital recording system were calculated by using a statistical analysis program (Appendix II).

One Supersonic X-2 parachute, one Supersonic X-3 parachute, and two Supersonic X-4 parachutes were tested. The Supersonic X-2 and X-3 parachutes were deployed at Mach number 4.0, and the Supersonic X-4 parachutes were deployed at Mach number 2.1, at a nominal free-stream dynamic pressure of 80 psf. The model forebody angle of attack and angle of sideslip were zero deg at all test conditions.

SECTION IV RESULTS AND DISCUSSION

4.1 PARACHUTE DYNAMIC CHARACTERISTICS

Drag-time history traces of the parachute deployments are presented in Fig. 8. Analysis of the motion picture films of each parachute deployment sequence showed that the canopies of the Supersonic X-2 and X-3 parachutes were not fully inflated at the deployment Mach number of 4.0 and that the canopies of the Supersonic X-4 parachutes were poorly inflated at the deployment Mach number of 2.1. Pulsing of the parachute canopy was observed for all of the parachutes, and the average pulse rate for all parachutes over an 8-sec interval was approximately 4.5 pulses per second. All of the parachutes exhibited negligible translational motion, and the canopy rotation rate, although sporadic for each parachute, varied from 0 to approximately 60 rpm. All of the parachutes tested failed shortly after deployment, and no data were obtained at Mach numbers other than the deployment Mach number test conditions.

The dynamic drag characteristics of each parachute tested were determined from a statistical analysis program (Appendix II). Dynamic drag coefficient, distribution plots for each parachute at the deployment Mach number test condition are presented in Fig. 9. Drag distribution parameters, average drag coefficient, standard deviation, skewness, and kurtosis, are tabulated on each plot. Also shown on each plot is the 95-percent confidence level interval calculated from the values of the drag distribution parameters. This interval can be interpreted as representing a qualitative measurement of the parachute drag dynamics at a 95-percent confidence level. Each of these plots summarizes the information obtained from approximately 16,000 data samples for each parachute tested. In general, these plots show that a drag coefficient value less than the average drag coefficient value occurred most often. A summary of the parachute dynamic statistical analysis results is presented in Table I (Appendix III).

4.2 PARACHUTE STEADY-STATE PERFORMANCE

The variation of parachute average drag coefficient with free-stream Mach number is shown in Fig. 10. The data presented in Fig. 10 were obtained by averaging the analog output of the load cell over 1-sec intervals, and these data agree with the average drag coefficient values determined from the statistical analysis program (Table I). As shown in Fig. 10, the drag coefficients of the Supersonic X-2 and X-3 parachutes

are in close agreement even though the geometric porosity of the Supersonic X-3 parachute was 94 percent greater than that of the Supersonic X-2 parachute. The drag coefficient values of the two Supersonic X-4 parachutes agree well, which is indicative of good data repeatability at Mach number 2.1.

SECTION V CONCLUDING REMARKS

Tests were conducted to determine deployment characteristics and aerodynamic performance of Supersonic X-2, X-3, and X-4 parachutes having geometric porosities of 13.4, 26.0, and 59.2 percent, respectively. One Supersonic X-2 parachute, one Supersonic X-3 parachute, and two Supersonic X-4 parachutes were tested. The Supersonic X-2 and X-3 parachutes were deployed at Mach number 4.0, and the Supersonic X-4 parachutes were deployed at Mach number 2.1 at a nominal free-stream dynamic pressure of 80 psf.

All parachutes failed shortly after deployment, and no data were obtained at Mach numbers other than the deployment Mach numbers. All of the parachutes exhibited sporadic pulsing of the canopy and had negligible translational motion. The canopies of the Supersonic X-2 and X-3 parachutes were not fully inflated at the deployment Mach number of 4.0, and the canopies of the Supersonic X-4 parachutes were poorly inflated at the deployment Mach number of 2.1.

APPENDIXES

- I. ILLUSTRATIONS**
- II. STATISTICAL ANALYSIS PROGRAM**
- III. TABLE**

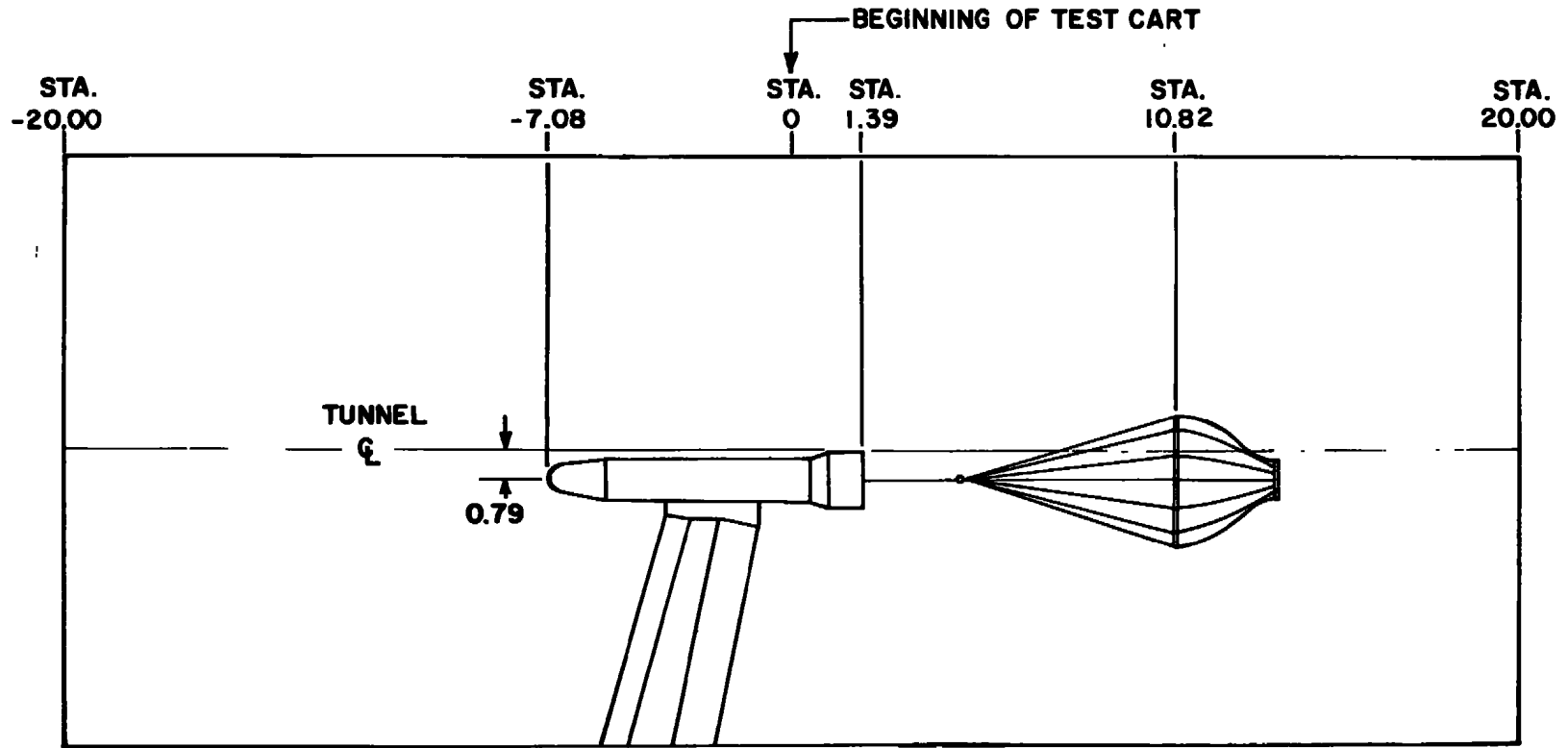

NOTE: ALL MODEL AND TUNNEL STATIONS ARE IN FEET

Fig. 1 Model Location in Test Section

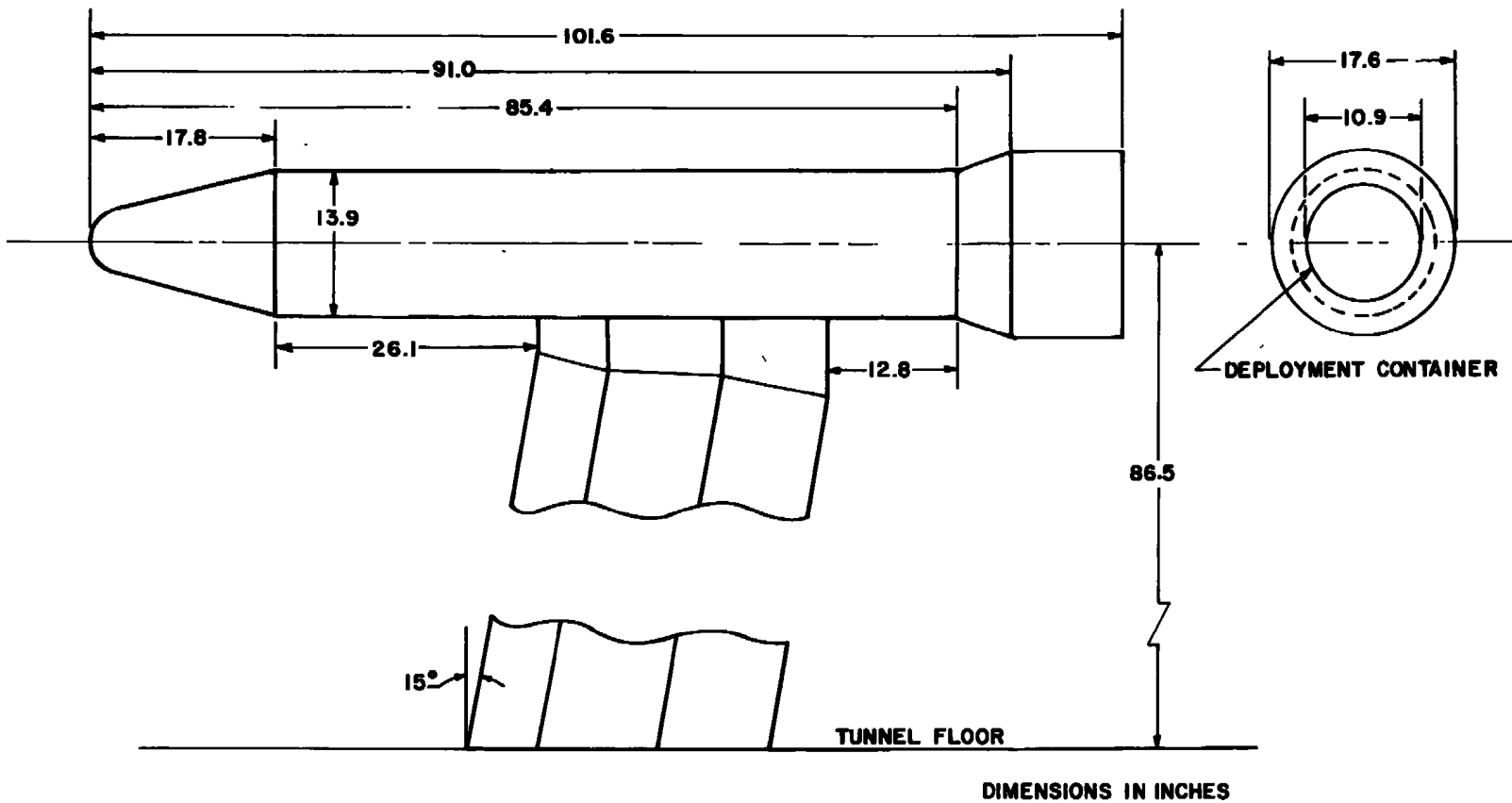

Fig. 2 Dimensioned Sketch of Model Forebody

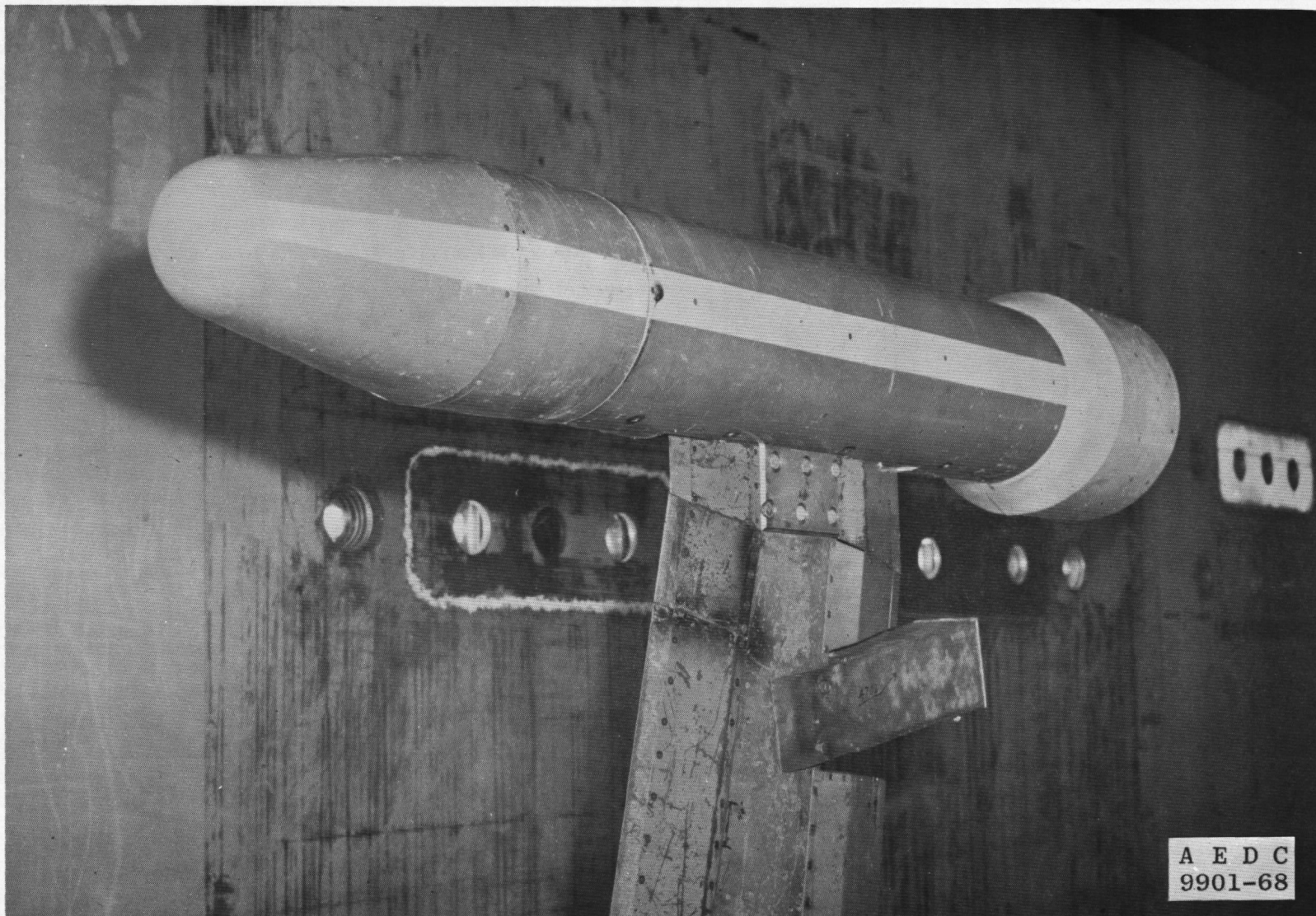

Fig. 3 Installation of Model Forebody in Test Section

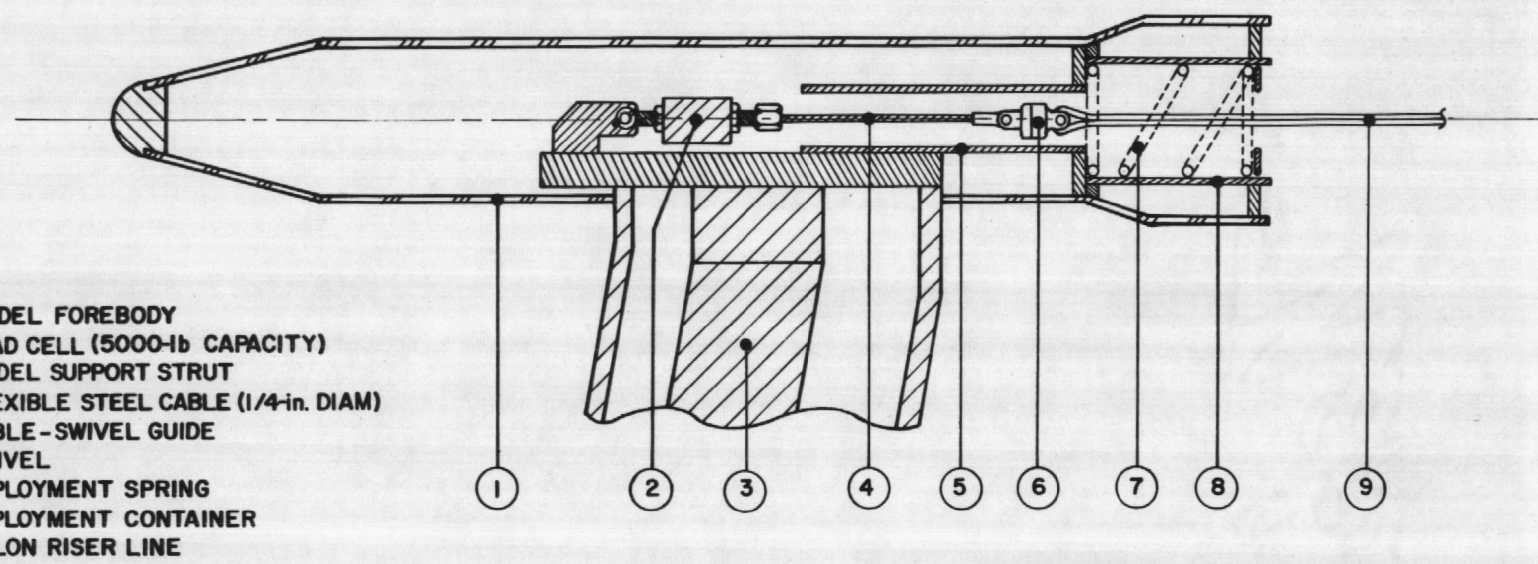

Fig. 4 Sketch of Model Forebody Showing Load Cell Installation

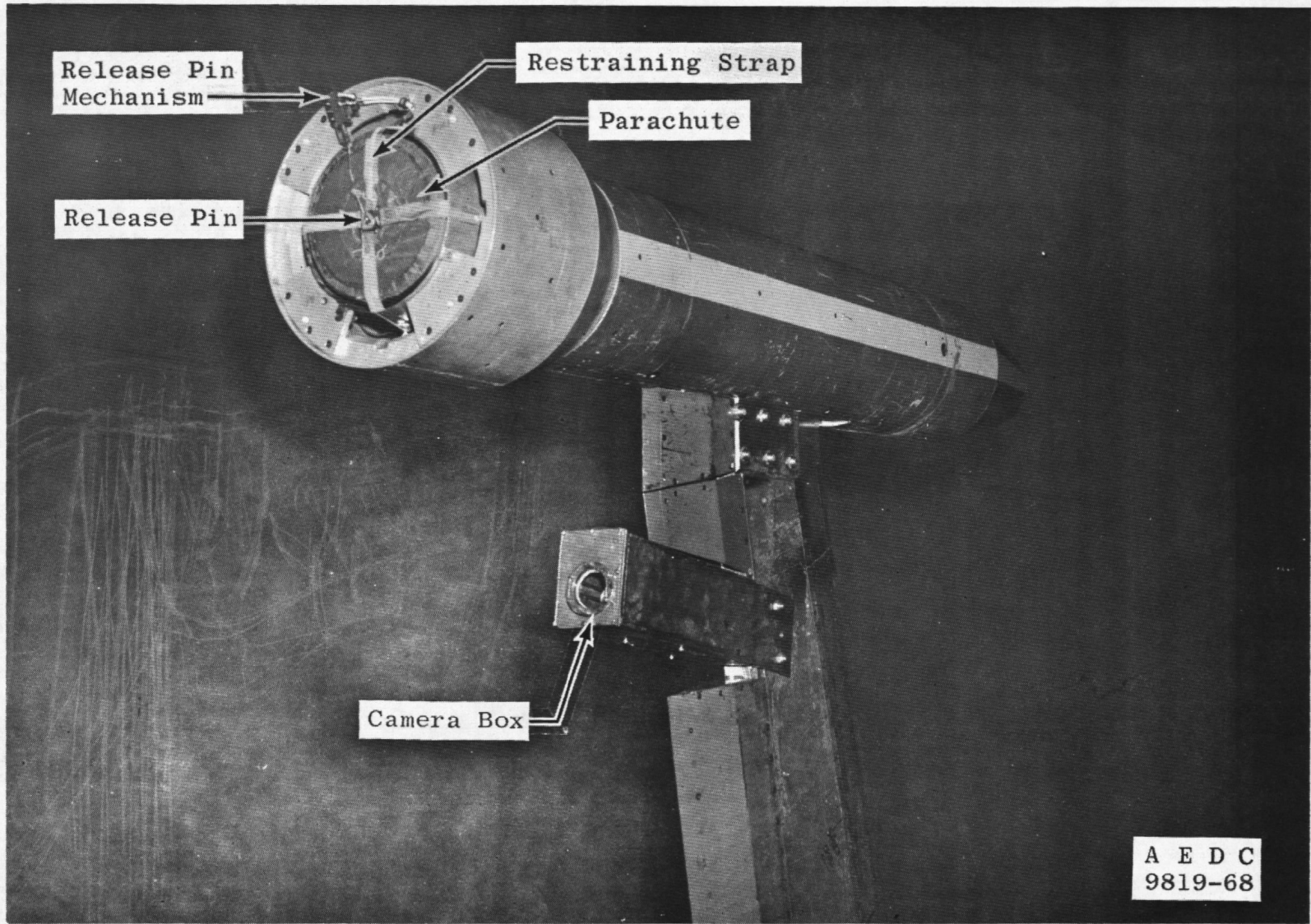

Fig. 5 Parachute Installation in Model Forebody

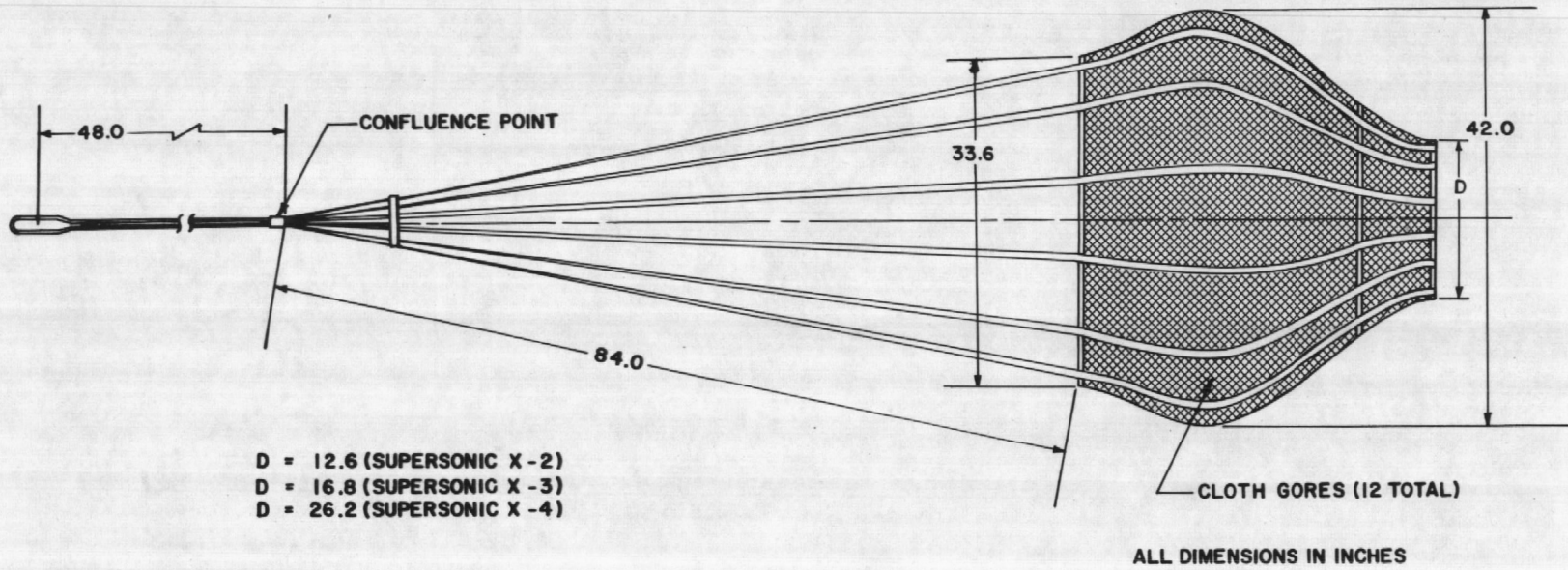
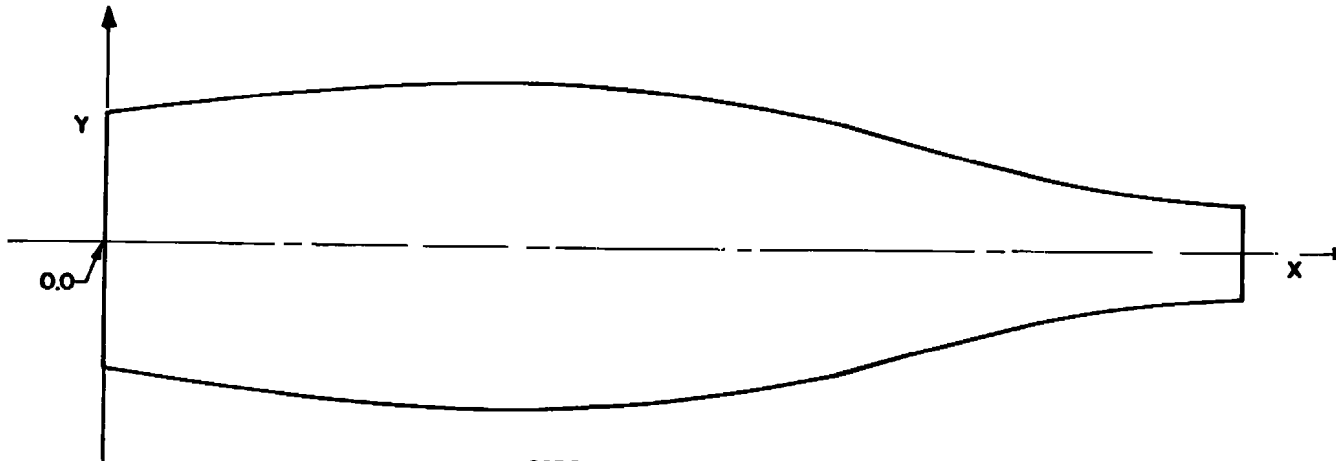

Fig. 6 Dimensioned Sketch of the Supersonic X Parachute



GORE COORDINATES

X	SUPERSONIC X-2	SUPERSONIC X-3	SUPERSONIC X-4
	Y	Y	Y
0.00	4.389	4.389	4.389
2.10	4.599	4.599	4.599
4.20	4.809	4.809	4.809
6.30	5.019	5.019	5.019
8.40	5.208	5.208	5.208
10.50	5.355	5.355	5.355
12.60	5.481	5.481	5.481
14.35	5.498	5.498	5.498
14.70	5.481	5.481	5.481
16.80	5.418	5.397	5.376
18.90	5.250	5.166	5.145
21.00	5.019	4.851	4.788
23.10	4.704	4.473	4.347
25.20	4.347	4.503	3.885
27.30	3.864	3.591	3.528
29.40	3.360	3.129	3.444
30.02	—	—	3.436
31.50	2.898	2.730	—
33.60	2.457	2.415	—
35.70	2.016	2.205	—
37.06	—	2.198	—
37.80	1.743	—	—
39.90	1.659	—	—
40.06	1.649	—	—

DIMENSIONS ARE IN INCHES

Fig. 7 Gore Dimensions of the Supersonic X Parachutes

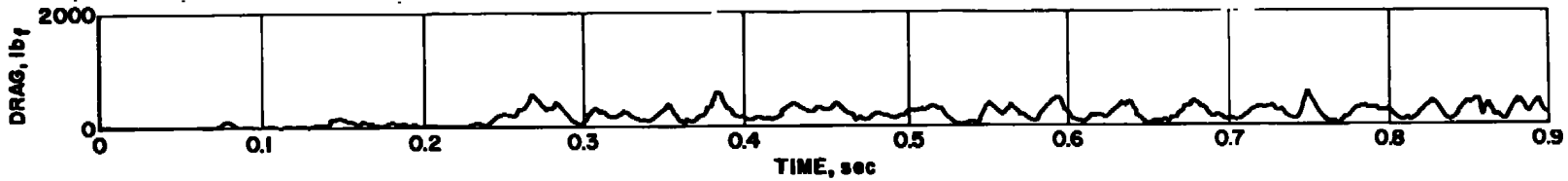

a. Supersonic X-2 Parachute, $M_{\infty} = 4.0$

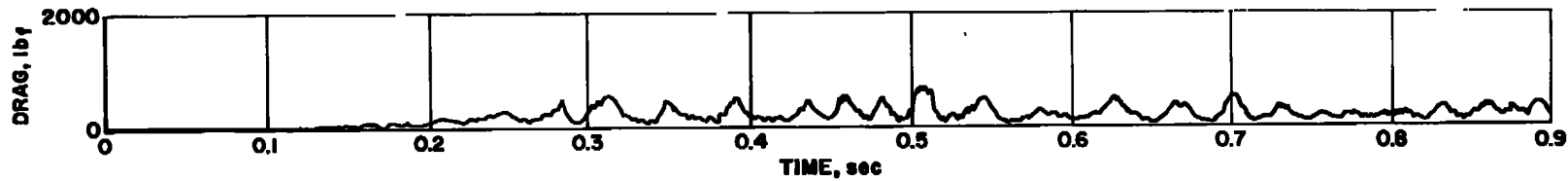

b. Supersonic X-3 Parachute, $M_{\infty} = 4.0$
Fig. 8 Parachute Deployment Characteristics

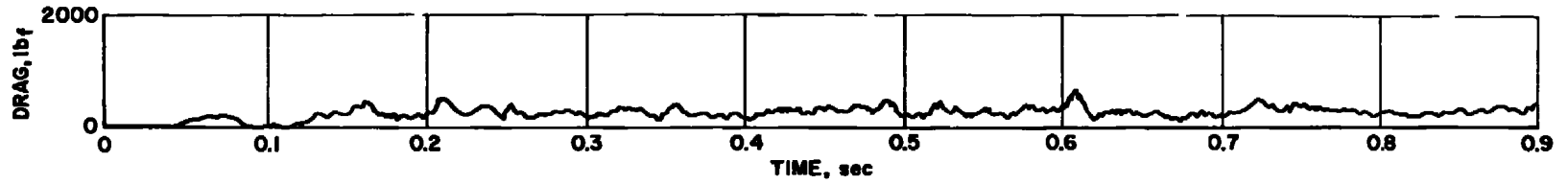

c. Supersonic X-4 Parachute, $M_{\infty} = 2.1$

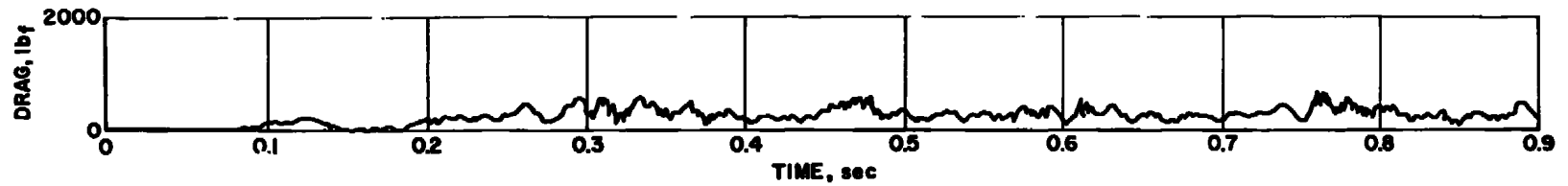

d. Backup Supersonic X-4 Parachute, $M_{\infty} = 2.1$

Fig. 8 Concluded

C_{Dp}	σ	SKEWNESS	KURTOSIS	(Ni)MAX.	N
0.2796	0.1603	0.6987	3.0102	700	15763

$C_{Dp} = 0.2796 \begin{matrix} +0.3650 \\ -0.2301 \end{matrix}$ (95% CONFIDENCE LEVEL)

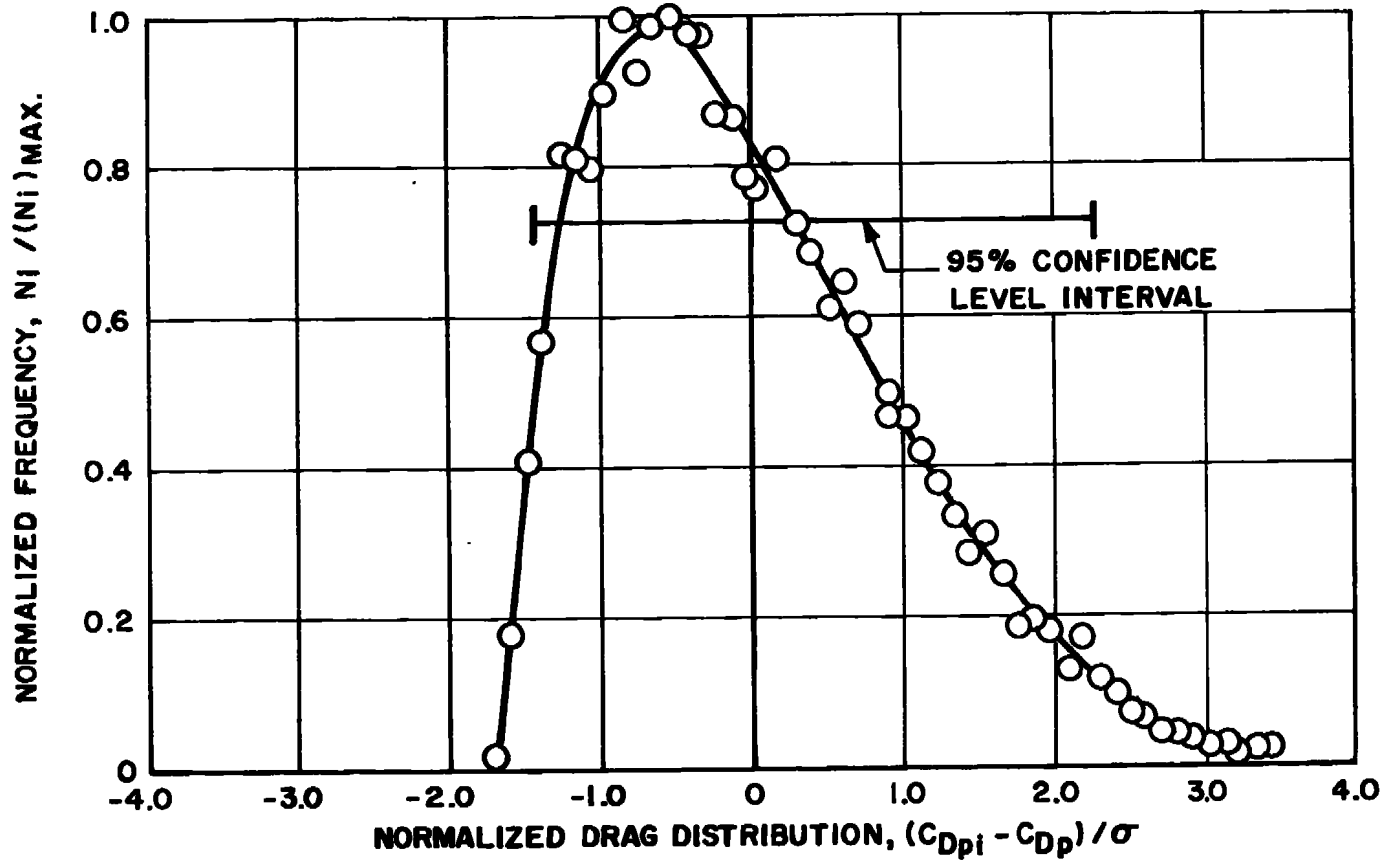

a. Supersonic X-2 Parachute, $M_\infty = 4.0$

Fig. 9 Distribution Plots of Parachute Drag Coefficient

C_{Dp}	σ	SKEWNESS	KURTOSIS	$(N_i)_{MAX.}$	N
0.2681	0.1419	0.5289	2.6701	616	15637

$C_{Dp} = 0.2681 \begin{matrix} +0.3090 \\ -0.2156 \end{matrix}$ (95 % CONFIDENCE LEVEL)

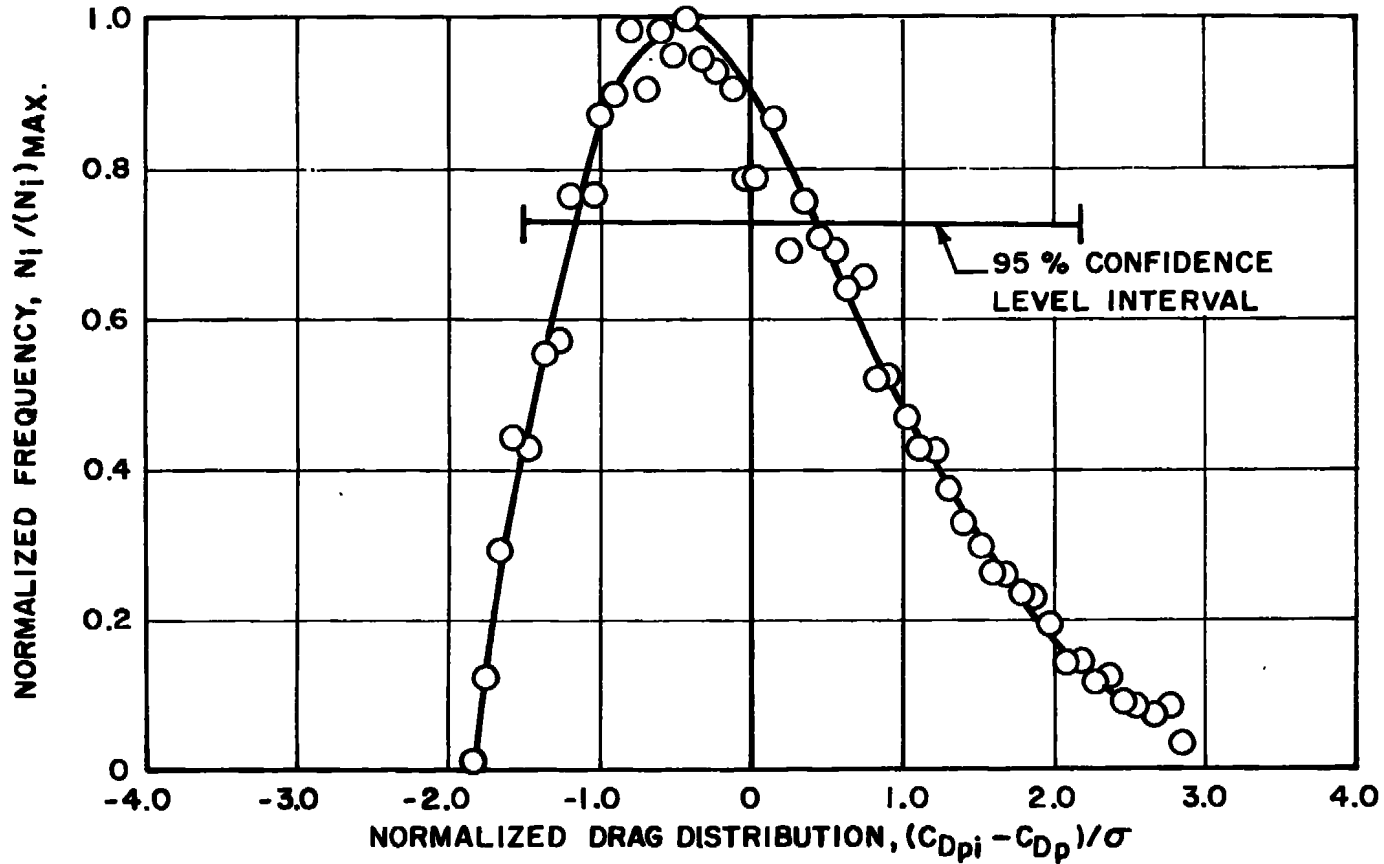

b. Supersonic X-3 Parachute, $M_{\infty} = 4.0$

Fig. 9 Continued

C_{Dp}	σ	SKEWNESS	KURTOSIS	$(N_i)_{MAX.}$	N
0.3644	0.1232	0.5690	3.1756	912	15819

$$C_{Dp} = 0.3644 \begin{matrix} +0.2733 \\ -0.2001 \end{matrix} \quad (95\% \text{ CONFIDENCE LEVEL})$$

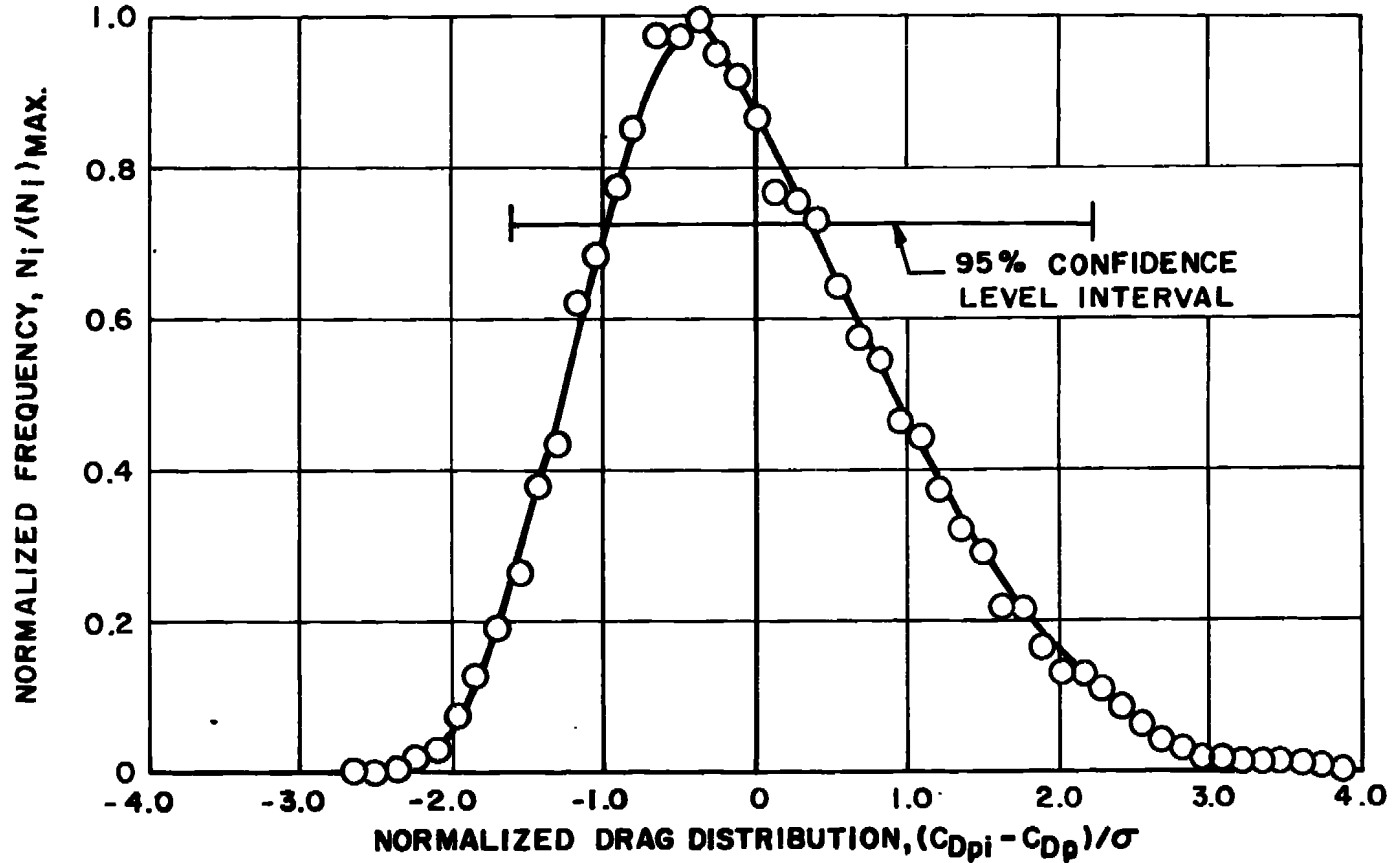

c. Supersonic X-4 Parachute, $M_{\infty} = 2.1$

Fig. 9 Continued

C_{Dp}	σ	SKEWNESS	KURTOSIS	$(N_i)_{MAX.}$	N
0.3721	0.1316	0.5991	3.1113	840	16011

$C_{Dp} = 0.3721 \begin{matrix} +0.2939 \\ -0.2080 \end{matrix}$ (95% CONFIDENCE LEVEL)

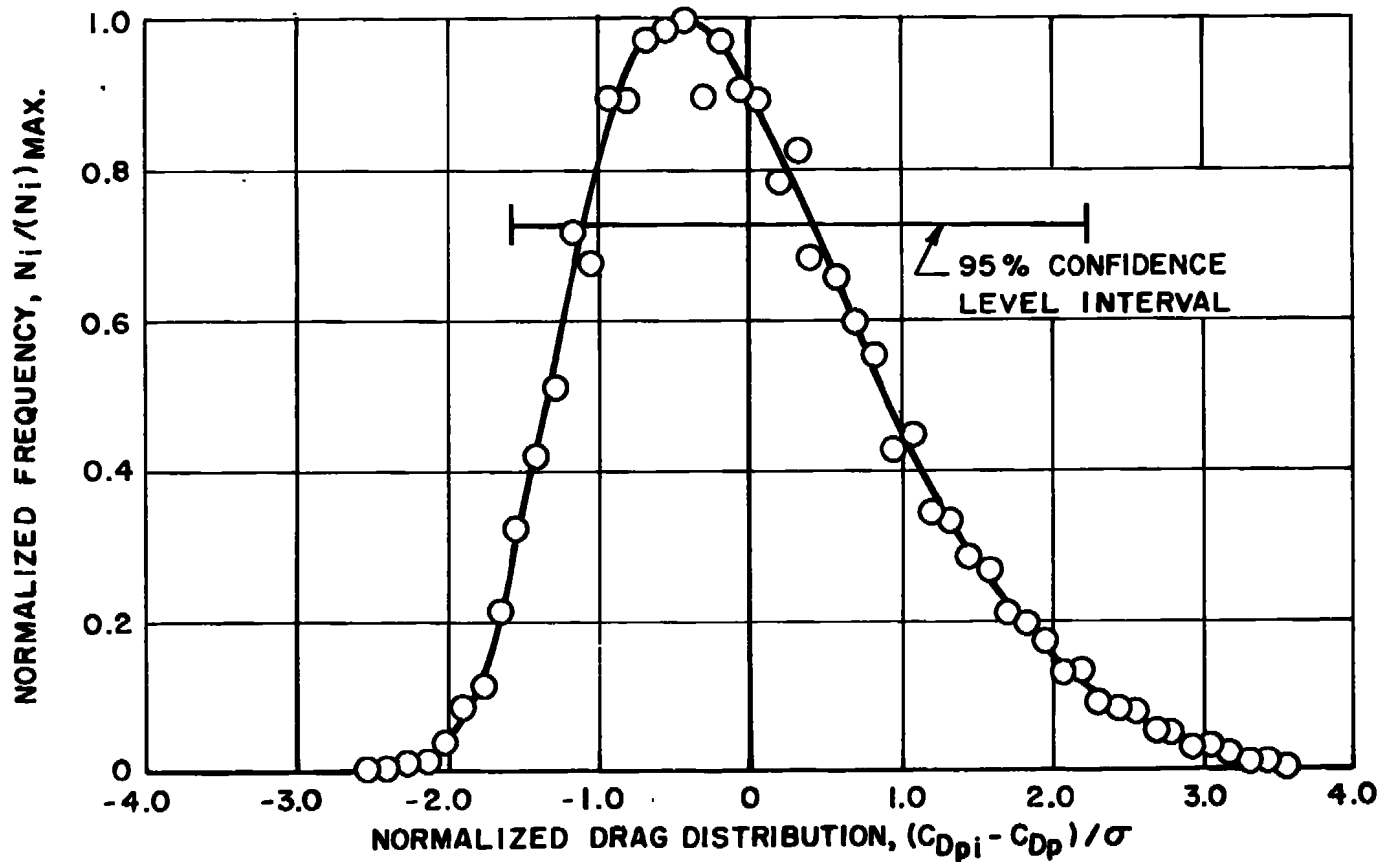

d. Backup Supersonic X-4 Parachute, $M_\infty = 2.1$

Fig. 9 Concluded

- SUPERSONIC X - 2
- SUPERSONIC X - 3
- ◇ SUPERSONIC X - 4

DARK SYMBOL = BACK-UP SUPERSONIC X-4 PARACHUTE

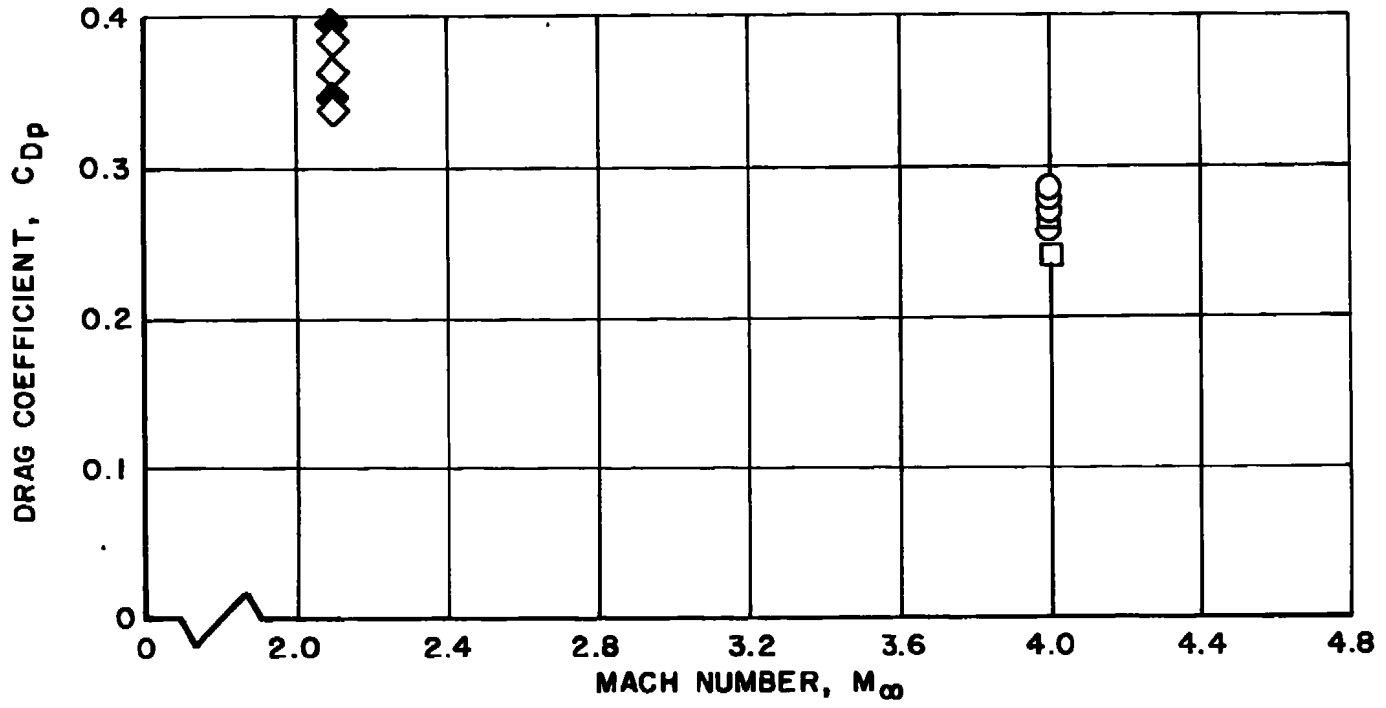

Fig. 10 Variation of Parachute Drag Coefficient with Mach Number

APPENDIX II STATISTICAL ANALYSIS PROGRAM

A statistical program was used to analyze the parachute dynamic drag data recorded by a high-speed digital recording system at a sampling rate of 1000 per second. In general, the statistical program permitted a qualitative evaluation to be made of the dynamic drag characteristics of each parachute tested during this investigation. The first four "central moments" - average drag coefficient, standard deviation, skewness, and kurtosis - were determined from each group of data samples obtained for each parachute tested, and these values were inspected for conformity to a normal (or Gaussian) distribution for the purpose of determining confidence levels. The significance of each central moment (or distribution parameters as they are referred to in this report) and the computer program written to obtain these parameters are briefly discussed.

DRAG DISTRIBUTION PARAMETERS

Average Drag Coefficient (C_{D_p})

The average value of a finite number of observations is the most probable value of the quantity. Expressed mathematically in terms of drag coefficient:

$$C_{D_p} = \frac{1}{N} \sum_{i=1}^n N_i C_{D_{p,i}}$$

where

$C_{D_{p,i}} = C_{D_{p1}}, C_{D_{p2}}, \dots, C_{D_{pn}}$ = mean drag coefficient value of each cell

$N_i = N_1, N_2, \dots, N_n$ = number of drag coefficient values of each cell

$N = N_1 + N_2 + \dots + N_n$ = total number of samples.

Standard Deviation (σ)

The standard deviation is the root-mean-square deviation of the mean drag coefficient value of each cell from the average drag coefficient value. Expressed mathematically,

$$\sigma = \left[\frac{1}{N} \sum_{i=1}^n N_i (C_{D_{p_i}} - C_{D_p})^2 \right]^{0.5}$$

Skewness ($\sqrt{\beta_1}$)

Skewness is a measure of the asymmetry of a distribution. The distribution is said to be positively or negatively skewed depending on whether the distribution extends to the right or left of the average drag coefficient value, respectively. Expressed mathematically and normalized with respect to standard deviation,

$$\sqrt{\beta_1} = \frac{1}{N\sigma^3} \sum_{i=1}^n N_i (C_{D_{p_i}} - C_{D_p})^3$$

Kurtosis (β_2)

Kurtosis is a measure of the peakedness of the distribution. Expressed mathematically and normalized with respect to standard deviation,

$$\beta_2 = \frac{1}{N\sigma^4} \sum_{i=1}^n N_i (C_{D_{p_i}} - C_{D_p})^4$$

The average drag coefficient and standard deviation are the most significant parameters of a distribution of data, whereas both skewness and kurtosis are important in that they indicate how well an actual distribution conforms to a normal distribution. For a normal distribution, skewness is zero and kurtosis has a value of three. If kurtosis for an actual distribution is greater than three, the distribution is more peaked than a normal distribution, and if kurtosis is less than three, the distribution is less peaked than a normal distribution.

The standard deviation for a normal distribution uniquely defines the percentage of all data that fall between specified confidence levels. For example, 68.27, 95.45, and 99.73 percent of all data will fall between $\pm 1\sigma$, $\pm 2\sigma$, and $\pm 3\sigma$, respectively, if the distribution is a normal distribution. For an actual distribution use of the Pearson distribution approximation², which is a function of skewness and kurtosis, permits

²Hahn, Gerald J. and Shapiro, Samuel S. Statistical Models in Engineering, John Wiley and Sons, Inc., New York, 1967.

an evaluation to be made of the percentage of all data that fall between specified confidence levels. For this investigation, the Pearson distribution approximation was used because the distribution of parachute dynamic drag data did not conform to a normal distribution with sufficient accuracy to justify the use of the confidence levels inherent for a normal distribution.

The most significant portion of the computer program that was written to obtain the distribution parameters of the parachute dynamic drag data was the procedure followed for grouping the data into a finite number of cells that covered the range of drag coefficient values recorded by the high-speed digital recording system. Each cell was assigned a given range of drag coefficient values and a mean drag coefficient value that was the average of that range. All cells were of equal span, and a total of 50 cells with appropriate cell boundaries was adequate for defining the distribution density plots presented in this report. The distributions density plots presented in this report represent the information obtained from approximately 16,000 data samples for each parachute tested.

TABLE I
SUMMARY OF PARACHUTE STATISTICAL ANALYSIS RESULTS

<u>Parachute</u>	<u>M_∞</u>	<u>C_{Dp}</u>	<u>σ</u>	<u>Skewness</u>	<u>Kurtosis</u>	<u>N</u>	95-percent Confidence Interval	
							<u>(C_{Dp})_{min}</u>	<u>(C_{Dp})_{max}</u>
X-2	4.0	0.2796	0.1603	0.6987	3.0102	15763	0.0495	0.6446
X-3	4.0	0.2681	0.1419	0.5289	2.6701	15637	0.0525	0.5771
X-4	2.1	0.3644	0.1232	0.5690	3.1756	15819	0.1643	0.6377
Backup X-4	2.1	0.3721	0.1316	0.5991	3.1113	16011	0.1641	0.6660

DOCUMENT CONTROL DATA - R & D

(Security classification of title, body of abstract and indexing annotation must be entered when the overall report is classified)

1. ORIGINATING ACTIVITY (Corporate author) Arnold Engineering Development Center ARO, Inc., Operating Contractor Arnold Air Force Station, Tennessee		2a. REPORT SECURITY CLASSIFICATION UNCLASSIFIED	
		2b. GROUP N/A	
3. REPORT TITLE AERODYNAMIC CHARACTERISTICS OF SUPERSONIC X PARACHUTES AT MACH NUMBERS OF 2.1 AND 4.0			
4. DESCRIPTIVE NOTES (Type of report and inclusive dates) October 24 to 30, 1968 - Final Report			
5. AUTHOR(S) (First name, middle initial, last name) Lawrence L. Galigher, ARO, Inc. <i>This document has been approved for public release PER TAB 72-21, its distribution is unlimited. Dtd 20 Dec, 72</i>			
6. REPORT DATE January 1969	7a. TOTAL NO. OF PAGES 32	7b. NO. OF REFS 0	
8a. CONTRACT OR GRANT NO. F40600-69-C-0001	9a. ORIGINATOR'S REPORT NUMBER(S) AEDC-TR-69-8		
b. PROJECT NO. 6065	9b. OTHER REPORT NO(S) (Any other numbers that may be assigned this report) N/A		
c. Program Element 62201F			
d. Task 606505			
10. DISTRIBUTION STATEMENT This document is subject to special export controls and each transmittal to foreign governments or foreign nationals may be made only with prior approval of AFFDL (FDFR), Wright-Patterson AFB, Ohio 45433.			
11. SUPPLEMENTARY NOTES Available in DDC		12. SPONSORING MILITARY ACTIVITY Air Force Flight Dynamics Laboratory (FDFR), Wright-Patterson AFB, Ohio 45433	
13. ABSTRACT A test was conducted in the Propulsion Wind Tunnel, Supersonic (16S), to determine deployment characteristics and aerodynamic performance of Supersonic X parachutes having geometric porosities of 13.4, 26.0, and 59.2 percent. Deployments were made from a cylindrical forebody having a flared aft section at free-stream Mach numbers of 2.1 and 4.0 at a nominal free-stream dynamic pressure of 80 psf. All of the parachutes tested failed shortly after deployment, and no data were obtained at Mach numbers other than the deployment Mach numbers. This document is subject to special export controls and each transmittal to foreign governments or foreign nationals may be made only with prior approval of AFFDL (FDFR), Wright-Patterson AFB, Ohio 45433. DISTRIBUTION LIMITED TO U. S. GOV'T AGENCIES ONLY; Test and Evaluation; 12 Nov. 71. Other requests for this document must be referred to Director, Air Force Flight Dynamics Lab., Attn: FDFR. Wright-Patterson AFB, Ohio 45433. PER TAB 72-21, dated 1 November, 1972.			

14. KEY WORDS	LINK A		LINK B		LINK C	
	ROLE	WT	ROLE	WT	ROLE	WT
parachutes — — aerodynamic characteristics deployment supersonic flow wind tunnel tests 1-15						