

UNCLASSIFIED

AD NUMBER

AD847382

LIMITATION CHANGES

TO:

Approved for public release; distribution is unlimited. Document partially illegible.

FROM:

Distribution authorized to DoD only; Administrative/Operational Use; JAN 1969. Other requests shall be referred to NASA Marshall Space Flight Center, Huntsville, AL. Document partially illegible.

AUTHORITY

USAEDC ltr, 12 Jul 1974

THIS PAGE IS UNCLASSIFIED

Cy1



**FLIGHT SUPPORT TESTING OF THE
J-2 ROCKET ENGINE IN
PROPULSION ENGINE TEST CELL (J-4)
(TESTS J4-1901-09 THROUGH J4-1901-11)**

H. J. Counts, Jr.

ARO, Inc.

January 1969

This document has been approved for public release
its distribution is unlimited.

Joe A. Colette
13 July 74
David Williams
C. Cole

Each transmittal of this document outside the Department of Defense must have prior approval of NASA, Marshall Space Flight Center (I-F-J), Huntsville, Alabama 35812.

**LARGE ROCKET FACILITY
ARNOLD ENGINEERING DEVELOPMENT CENTER
AIR FORCE SYSTEMS COMMAND
ARNOLD AIR FORCE STATION, TENNESSEE**

PROPERTY OF U. S. AIR FORCE
AEDC LIBRARY
F40600-69-C-0001



NOTICES

When U. S. Government drawings specifications, or other data are used for any purpose other than a definitely related Government procurement operation, the Government thereby incurs no responsibility nor any obligation whatsoever, and the fact that the Government may have formulated, furnished, or in any way supplied the said drawings, specifications, or other data, is not to be regarded by implication or otherwise, or in any manner licensing the holder or any other person or corporation, or conveying any rights or permission to manufacture, use, or sell any patented invention that may in any way be related thereto.

Qualified users may obtain copies of this report from the Defense Documentation Center.

References to named commercial products in this report are not to be considered in any sense as an endorsement of the product by the United States Air Force or the Government.

FLIGHT SUPPORT TESTING OF THE
J-2 ROCKET ENGINE IN
PROPULSION ENGINE TEST CELL (J-4)
(TESTS J4-1901-09 THROUGH J4-1901-11)

H. J. Counts, Jr.
ARO, Inc.

Each transmittal of this document outside the Department of Defense must have prior approval of NASA, Marshall Space Flight Center (I-F-J), Huntsville, Alabama 35812.

This document has been approved for public release
its distribution is unlimited.

*Per AF Letter
dated 12 Feb, 74,
signed William
O. Cole.*

FOREWORD

The work reported herein was sponsored by the National Aeronautics and Space Administration (NASA), Marshall Space Flight Center (MSFC) (I-E-J), under System 921E, Project 9194.

The results of the tests presented were obtained by ARO, Inc. (a subsidiary of Sverdrup & Parcel and Associates, Inc.), contract operator of the Arnold Engineering Development Center (AEDC), Air Force Systems Command (AFSC), Arnold Air Force Station, Tennessee, under Contract F40600-69-C-0001. Program direction was provided by NASA/MSFC; engineering liaison was provided by North American Rockwell Corporation, Rocketdyne Division, manufacturer of the J-2 rocket engine and McDonnell Douglas Corporation, Missile and Space Systems Division, manufacturer of the S-IVB stage. The testing reported herein was conducted between September 4 and 24, 1968, in Propulsion Engine Test Cell (J-4) of the Large Rocket Facility (LRF) under ARO Project No. KA1901. The manuscript was submitted for publication on November 4, 1968.

Information in this report is embargoed under the Department of State International Traffic in Arms Regulations. This report may be released to foreign governments by departments or agencies of the U. S. Government subject to approval of NASA, Marshall Space Flight Center (I-E-J), Huntsville, Alabama, or higher authority. Private individuals or firms require a Department of State export license.

This technical report has been reviewed and is approved.

Edgar D. Smith
Major, USAF
AF Representative, LRF
Directorate of Test

Roy R. Croy, Jr.
Colonel, USAF
Director of Test

ABSTRACT

Fourteen firings of the Rocketdyne J-2 rocket engine were conducted during test periods J4-1901-09, 10, and 11 between September 4 and 24, 1968, in Test Cell (J-4) of the Large Rocket Facility. The firings were accomplished at pressure altitudes ranging from 81,000 to 107,000 ft at engine start. Basic test objectives were to evaluate the effect on the engine start transient of (1) different configuration gas generator oxidizer supply lines, (2) gaseous helium as a start tank pressurant, (3) start tank pressures ranging from 600 to 1000 psia, and (4) a simulated gas generator fuel poppet leak. Engine components were thermally conditioned to temperatures representative of S-IVB engine/interstage environment for a first burn, 80-min restart, or 6-hr restart. The total accumulated firing duration for the three test periods was 181.6 sec.

This document is subject to special export controls and each transmittal to foreign governments or foreign nationals may be made only with prior approval of NASA, Marshall Space Flight Center (I-E-J), Huntsville, Alabama 35812.

This document has been approved for public release
 and its distribution is unlimited.

*Ray A. Fetter
 etc 12 July 74
 signed William
 A. Cole.*

CONTENTS

	<u>Page</u>
ABSTRACT	iii
NOMENCLATURE	ix
I. INTRODUCTION	1
II. APPARATUS	1
III. PROCEDURE	7
IV. RESULTS AND DISCUSSION	8
V. SUMMARY OF RESULTS	21
REFERENCES	21

APPENDIXES

I. ILLUSTRATIONS

Figure

1. Test Cell J-4 Complex	25
2. Test Cell J-4, Artist's Conception	26
3. Engine Details.	27
4. S-IVB Battleship Stage/J-2 Engine Schematic	30
5. Engine Schematic	31
6. Engine Start Logic Schematic	32
7. Engine Start and Shutdown Sequence	33
8. Engine Start Conditions for the Pump Inlets, Start Tank, and Helium Tank	35
9. Thermal Conditioning History of Engine Components, Firing 09A	39
10. Engine Transient Operation, Firing 09A	40
11. Fuel Pump Start Transient Performance, Firing 09A	42
12. Engine Ambient and Combustion Chamber Pressure, Firing 09A	43
13. Thermal Conditioning History of Engine Components, Firing 09B	44

<u>Figure</u>	<u>Page</u>
14. Engine Transient Operation, Firing 09B	45
15. Fuel Pump Start Transient Performance, Firing 09B	49
16. Engine Ambient and Combustion Chamber Pressure, Firing 09B	50
17. Thermal Conditioning History of Engine Components, Firing 09C	51
18. Engine Transient Operation, Firing 09C	52
19. Fuel Pump Start Transient Performance, Firing 09C	56
20. Engine Ambient and Combustion Chamber Pressure, Firing 09C	57
21. Thermal Conditioning History of Engine Components, Firing 09D	58
22. Engine Transient Operation, Firing 09D	59
23. Fuel Pump Start Transient Performance, Firing 09D	63
24. Engine Ambient and Combustion Chamber Pressure, Firing 09D	64
25. Thermal Conditioning History of Engine Components, Firing 09E	65
26. Engine Transient Operation, Firing 09E	66
27. Fuel Pump Start Transient Performance, Firing 09E	70
28. Engine Ambient and Combustion Chamber Pressure, Firing 09E	71
29. Thermal Conditioning History of Engine Components, Firing 09F	72
30. Engine Transient Operation, Firing 09F	73
31. Fuel Pump Start Transient Performance, Firing 09F	75
32. Engine Ambient and Combustion Chamber Pressure, Firing 09F	76

<u>Figure</u>	<u>Page</u>
33. Thermal Conditioning History of Engine Components, Firing 10A	77
34. Engine Transient Operation, Firing 10A	78
35. Fuel Pump Start Transient Performance, Firing 10A	82
36. Engine Ambient and Combustion Chamber Pressure, Firing 10A	83
37. Thermal Conditioning History of Engine Components, Firing 10B	84
38. Engine Transient Operation, Firing 10B	85
39. Fuel Pump Start Transient Performance, Firing 10B	89
40. Engine Ambient and Combustion Chamber Pressure, Firing 10B	90
41. Thermal Conditioning History of Engine Components, Firing 11A	91
42. Engine Transient Operation, Firing 11A	92
43. Fuel Pump Start Transient Performance, Firing 11A	96
44. Engine Ambient and Combustion Chamber Pressure, Firing 11A	97
45. Thermal Conditioning History of Engine Components, Firing 11B	98
46. Engine Transient Operation, Firing 11B	99
47. Fuel Pump Start Transient Performance, Firing 11B	103
48. Engine Ambient and Combustion Chamber Pressure, Firing 11B	104
49. Thermal Conditioning History of Engine Components, Firing 11C	105
50. Engine Transient Operation, Firing 11C	106
51. Fuel Pump Start Transient Performance, Firing 11C	110

<u>Figure</u>	<u>Page</u>
52. Engine Ambient and Combustion Chamber Pressure, Firing 11C	111
53. Thermal Conditioning History of Engine Components, Firing 11D	112
54. Engine Transient Operation, Firing 11D	113
55. Fuel Pump Start Transient Performance, Firing 11D	117
56. Engine Ambient and Combustion Chamber Pressure, Firing 11D	118
57. Thermal Conditioning History of Engine Components, Firing 11E	119
58. Engine Transient Operation, Firing 11E	120
59. Fuel Pump Start Transient Performance, Firing 11E	122
60. Engine Ambient and Combustion Chamber Pressure, Firing 11E	123
61. Thermal Conditioning History of Engine Components, Firing 11F	124
62. Engine Transient Operation, Firing 11F	125
63. Fuel Pump Start Transient Performance, Firing 11F	127
64. Engine Ambient and Combustion Chamber Pressure, Firing 11F	128
65. Start Tank Pressure Effects on Engine Start Transient Performance	129
66. Start Tank Pressure Effect on Fuel Pump Start Transient Performance	130
 II. TABLES	
I. Major Engine Components	131
II. Summary of Engine Orifices	132
III. Engine Modifications (between Tests J4-1901-09 and J4-1901-11)	133
IV. Engine Component Replacements (between Tests J4-1901-09 and J4-1901-11)	134

	<u>Page</u>
II. TABLES (Con't)	
V. Engine Purge and Component Conditioning Sequence	135
VI. Summary of Test Requirements and Results	136
VII. Engine Valve Timings	139
VIII. Engine Performance Summary	142
III. INSTRUMENTATION	143
IV. METHODS OF CALCULATION (PERFORMANCE PROGRAM)	154

NOMENCLATURE

A	Area, in. ²
ASI	Augmented spark igniter
ES	Engine start, designated as the time that helium control and ignition phase solenoids are energized
GG	Gas generator
MÓV	Main oxidizer valve
STDV	Start tank discharge valve
t ₀	Defined as the time at which the opening signal is applied to the start tank discharge valve solenoid
VSC	Vibration safety counts, defined as the time at which engine vibration was in excess of 150 g rms in a 960- to 6000-Hz frequency range

SUBSCRIPTS

f	Force
m	Mass
t	Throat

SECTION I INTRODUCTION

Testing of the Rocketdyne J-2 rocket engine using an S-IVB battleship stage has been in progress since July, 1966, at AEDC in support of the J-2 engine application of the Saturn IB and Saturn V launch vehicles for the NASA Apollo Program. The 14 firings reported herein were conducted during test periods J4-1901-09 through 11 between September 4 and 24, 1968, in Propulsion Engine Test Cell (J-4) (Figs. 1 and 2, Appendix I) of the Large Rocket Facility (LRF). This series of firings consisted of S-IVB restarts (80-min and 6-hr simulated orbital coast times) and one first burn for evaluation of gas generator oxidizer supply lines of differing internal configuration. Other objectives included evaluation of engine start transients utilizing gaseous helium as a start tank pressurant, start tank pressures ranging from 600 to 1000 psia, and a simulated gas generator fuel poppet leak.

The firings were conducted at pressure altitudes ranging from 81,000 to 107,000 ft (geometric pressure altitude, Z , Ref. 1) at engine start. Engine components were conditioned to predicted S-IVB interstage/engine temperatures. Data collected to accomplish the test objectives are presented herein. The results of the previous test period are presented in Ref. 2.

SECTION II APPARATUS

2.1 TEST ARTICLE

The test article was a J-2 rocket engine (Fig. 3) designed and developed by Rocketdyne Division of North American Rockwell Corporation. The engine uses liquid oxygen and liquid hydrogen as propellants and has a thrust rating of 230,000 lbf at an oxidizer-to-fuel mixture ratio of 5.5. An S-IVB battleship stage was used to supply propellants to the engine. A schematic of the battleship stage is presented in Fig. 4.

Listings of major engine components and engine orifices for this test period are presented in Tables I and II, respectively (Appendix II). All engine modifications and component replacements performed since the previous test period are presented in Tables III and IV, respectively.

2.1.1 J-2 Rocket Engine

The J-2 rocket engine (Figs. 3 and 5, Ref. 3) features the following major components:

1. **Thrust Chamber** - The tubular-walled, bell-shaped thrust chamber consists of an 18.6-in.-diam combustion chamber (8.0 in. long from the injector mounting to the throat inlet) with a characteristic length (L^*) of 24.6 in., a 170.4-in.² throat area, and a divergent nozzle with an expansion ratio of 27.1. Thrust chamber length (from the injector flange to the nozzle exit) is 107 in. Cooling is accomplished by the circulation of engine fuel flow downward from the fuel manifold through 180 tubes and then upward through 360 tubes to the injector.
2. **Thrust Chamber Injector** - The injector is a concentric-orificed (concentric fuel orifices around the oxidizer post orifices), porous-faced injector. Fuel and oxidizer injector orifice areas are 25.0 and 16.0 in.², respectively. The porous material, forming the injector face, allows approximately 3.5 percent of total fuel flow to transpiration cool the face of the injector.
3. **Augmented Spark Igniter** - The augmented spark igniter unit is mounted on the thrust chamber injector and supplies the initial energy source to ignite propellants in the main combustion chamber. The augmented spark igniter chamber is an integral part of the thrust chamber injector. Fuel and oxidizer are ignited in the combustion area by two spark plugs.
4. **Fuel Turbopump** - The turbopump is composed of a two-stage turbine-stator assembly, an inducer, and a seven-stage axial-flow pump. The pump is self lubricated and nominally produces, at rated conditions, a head rise of 38,215 ft (1248 psia) of liquid hydrogen at a flow rate of 8585 gpm for a rotor speed of 27,265 rpm.
5. **Oxidizer Turbopump** - The turbopump is composed of a two-stage turbine-stator assembly and a single-stage centrifugal pump. The pump is self lubricated and nominally produces, at rated conditions, a head rise of 2170 ft (1107 psia) of liquid oxygen at a flow rate of 2965 gpm for a rotor speed of 8688 rpm.
6. **Gas Generator** - The gas generator consists of a combustion chamber containing two spark plugs, a pneumatically operated control valve containing oxidizer and fuel poppets, and an injector assembly. The oxidizer and fuel poppets provide a fuel lead to the gas generator combustion chamber. The high energy gases produced by the gas generator are directed to the fuel

turbine and then to the oxidizer turbine (through the turbine crossover duct) before being exhausted into the thrust chamber at an area ratio (A/A_t) of approximately 11.

7. Propellant Utilization Valve - The motor-driven propellant utilization valve is mounted on the oxidizer turbopump and bypasses liquid oxygen from the discharge to the inlet side of the pump to vary engine mixture ratio.
8. Propellant Bleed Valves - The pneumatically operated fuel and oxidizer bleed valves provide pressure relief for the boiloff of propellants trapped between the battleship stage prevalues and main propellant valves at engine shutdown.
9. Integral Hydrogen Start Tank and Helium Tank - The integral tanks consist of a 7258-in.³ sphere for hydrogen with a 1000-in.³ sphere for helium located within it. Pressurized gaseous hydrogen in the start tank provides the initial energy source for spinning the propellant turbopumps during engine start. The helium tank provides a helium pressure supply to the engine pneumatic control system.
10. Oxidizer Turbine Bypass Valve - The pneumatically actuated oxidizer turbine bypass valve provides control of the fuel turbine exhaust gases directed to the oxidizer turbine in order to control the oxidizer-to-fuel turbine spinup relationship. The fuel turbine exhaust gases which bypass the oxidizer turbine are discharged into the thrust chamber.
11. Main Oxidizer Valve - The main oxidizer valve is a pneumatically actuated, two-stage, butterfly-type valve located in the oxidizer high pressure duct between the turbopump and the main injector. The first-stage actuator positions the main oxidizer valve at the 14-deg position to obtain initial thrust chamber ignition; the second-stage actuator ramps the main oxidizer valve full open to accelerate the engine to main-stage operation.
12. Main Fuel Valve - The main fuel valve is a pneumatically actuated butterfly-type valve located in the fuel high pressure duct between the turbopump and the fuel manifold.
13. Pneumatic Control Package - The pneumatic control package controls all pneumatically operated engine valves and purges.
14. Electrical Control Assembly - The electrical control assembly provides the electrical logic required for proper sequencing of engine components during operation.

15. Primary and Auxiliary Flight Instrumentation Packages - The instrumentation packages contain sensors required to monitor critical engine parameters. The packages provide environmental control for the sensors.

2.1.2 Oxidizer Supply Line to Gas Generator

The gas generator oxidizer supply line assembly (Fig. 3b) utilized on test periods 09 and 10 was the same configuration as the assembly utilized on the previous tests (Ref. 2). An X-ray photograph of the bellows section of this assembly, manufactured by the Anaconda American Brass Company, is shown in Fig. 3c. The assembly utilized for test period 11 was identical to that of test periods 09 and 10 except for the internal geometry of the flexible bellows section. An X-ray photograph of the bellows section utilized on test period 11 is shown in Fig. 3d. This bellows section was manufactured by the Avica Corporation. The assemblies P/N 408710 and P/N NA5-260113 are hereafter referred to as the Anaconda and Avica lines, respectively.

2.1.3 S-IVB Battleship Stage

The S-IVB battleship stage is approximately 22 ft in diameter and 49 ft long and has a maximum propellant capacity of 46,000 lb of liquid hydrogen and 199,000 lb of liquid oxygen. The propellant tanks, fuel above oxidizer, are separated by a common bulkhead. Propellant pre-valves, in the low pressure ducts (external to the tanks) interfacing the stage and the engine, retain propellant in the stage until being admitted into the engine to the main propellant valves and serve as emergency engine shutoff valves. Propellant recirculation pumps in both fuel and oxidizer tanks are utilized to circulate propellants through the low pressure ducts and turbopumps before engine start to stabilize hardware temperatures near normal operating levels and to prevent propellant temperature stratification. Vent and relief valve systems are provided for both propellant tanks.

Pressurization of the fuel and oxidizer tanks was accomplished by facility systems using hydrogen and helium, respectively, as the pressurizing gases. The engine-supplied gaseous hydrogen for fuel tank pressurization during S-IVB flight was routed to the facility venting system.

2.2 TEST CELL

Test Cell J-4, Fig. 2, is a vertically oriented test unit designed for static testing of liquid-propellant rocket engines and propulsion systems

at pressure altitudes of 100,000 ft. The basic cell construction provides a 1.5-million-lbf-thrust capacity. The cell consists of four major components (1) test capsule, 48 ft in diameter and 82 ft in height, situated at grade level and containing the test article; (2) spray chamber, 100 ft in diameter and 250 ft in depth, located directly beneath the test capsule to provide exhaust gas cooling and dehumidification; (3) coolant water, steam, nitrogen (gaseous and liquid), hydrogen (gaseous and liquid), and liquid oxygen and gaseous helium storage and delivery systems for operation of the cell and test article; and (4) control building, containing test article controls, test cell controls, and data acquisition equipment. Exhaust machinery is connected with the spray chamber and maintains a minimum test cell pressure before and after the engine firing and exhausts the products of combustion from the engine firing. Before a firing, the facility steam ejector, in series with the exhaust machinery, provides a pressure altitude of 100,000 ft in the test capsule. A detailed description of the test cell is presented in Ref. 4.

The battleship stage and the J-2 engine were oriented vertically downward on the centerline of the diffuser-steam ejector assembly. This assembly consisted of a diffuser duct (20 ft in diameter by 150 ft in length), a centerbody steam ejector within the diffuser duct, a diffuser insert (13.5 ft in diameter by 30 ft in length) at the inlet to the diffuser duct, and a gaseous nitrogen annular ejector above the diffuser insert. The diffuser insert was provided for dynamic pressure recovery of the engine exhaust gases and to maintain engine ambient pressure altitude (attained by the steam ejector) during the engine firing. The annular ejector was provided to suppress steam recirculation into the test capsule during steam ejector shutdown. The test cell was also equipped with (1) a gaseous nitrogen purge system for continuously inerting the normal air in-leakage of the cell; (2) a gaseous nitrogen repressurization system for raising test cell pressure, after engine cutoff, to a level equal to spray chamber pressure and for rapid emergency inerting of the capsule; and (3) a spray chamber liquid nitrogen supply and distribution manifold for initially inerting the spray chamber and exhaust ducting and for increasing the molecular weight of the hydrogen-rich exhaust products.

An engine component conditioning system was provided for temperature conditioning engine components. The conditioning system utilized a liquid hydrogen-helium heat exchanger to provide cold helium gas for component conditioning. Engine components requiring temperature conditioning were the thrust chamber, crossover duct, and main oxidizer valve second-stage actuator. Helium was routed internally through the crossover duct and tubular-walled thrust chamber. Main

oxidizer valve conditioning was achieved by opening the pre valves and permitting propellants into the engine.

2.3 INSTRUMENTATION

Instrumentation systems were provided to measure engine, stage, and facility parameters. The engine instrumentation was comprised of (1) flight instrumentation for the measurement of critical engine parameters and (2) facility instrumentation which was provided to verify the flight instrumentation and to measure additional engine parameters. The flight instrumentation was provided and calibrated by the engine manufacturer; facility instrumentation was initially calibrated and periodically recalibrated at AEDC. Appendix III contains a list of all measured test parameters and the locations of selected sensing points.

Pressure measurements were made using strain-gage-type pressure transducers and a capacitance-type Photocon[®] transducer. Temperature measurements were made using resistance temperature transducers and thermocouples. Oxidizer and fuel turbopump shaft speeds were sensed by magnetic pickup. Fuel and oxidizer flow rates to the engine were measured by turbine-type flowmeters which are an integral part of the engine. The propellant recirculation flow rates were also monitored with turbine-type flowmeters. Vibrations were measured by accelerometers mounted on the oxidizer injector dome and on the turbopumps. Primary engine and stage valves were instrumented with linear potentiometers and limit switches.

The data acquisition systems were calibrated by (1) precision electrical shunt resistance substitution for the pressure transducers and resistance temperature transducer units; (2) voltage substitution for the thermocouples; (3) frequency substitution for shaft speeds and flowmeters; and (4) frequency-voltage substitution for accelerometers and Photocon unit.

The types of data acquisition and recording systems used during this test period were (1) a multiple-input digital data acquisition system (Microsadic[®]) scanning each parameter at 40 samples per second and recording on magnetic tape; (2) single-input, continuous-recording FM systems recording on magnetic tape; (3) photographically recording galvanometer oscillographs; (4) direct-inking, null-balance potentiometer-type X-Y plotters and strip charts; and (5) optical data recorders. Applicable systems were calibrated before each test (atmospheric and altitude calibrations). Television cameras, in conjunction with video tape recorders, were used to provide visual coverage during an engine firing,

as well as for replay capability for immediate examination of unexpected events.

2.4 CONTROLS

Control of the J-2 engine, battleship stage, and test cell systems during the terminal countdown was provided from the test cell control room. A facility control logic network was provided to interconnect the engine control system, major stage systems, the engine safety cutoff system, the observer cutoff circuits, and the countdown sequencer. A schematic of the engine start control logic is presented in Fig. 6. The sequence of engine events for a normal start and shutdown is presented in Figs. 7a and b. Two control logics for sequencing the stage pre-valves and recirculation systems with engine start for simulating engine flight start sequences are presented in Figs. 7c and d.

SECTION III PROCEDURE

Preoperational procedures were begun several hours before the test period. All consumable storage systems were replenished, and engine inspections, leak checks, and drying procedures were conducted. Propellant tank pressurants and engine pneumatic and purge gas samples were taken to ensure that specification requirements were met. Chemical analysis of propellants was provided by the propellant suppliers. Facility sequence, engine sequence, and engine abort checks were conducted within a 24-hr time period before an engine firing to verify the proper sequence of events. Facility and engine sequence checks consisted of verifying the timing of valves and events to be within specified limits; the abort checks consisted of electrically simulating engine malfunctions to verify the occurrence of an automatic engine cutoff signal. A final engine sequence check was conducted immediately preceding the test period.

Oxidizer dome, gas generator oxidizer injector, and thrust chamber jacket purges were initiated before evacuating the test cell. After completion of instrumentation calibrations at atmospheric conditions, the test cell was evacuated to approximately 0.5 psia with the exhaust machiner, and instrumentation calibrations at altitude conditions were conducted. Immediately before loading propellants on board the vehicle, the cell and exhaust-ducting atmosphere was inerted. At this same time, the cell nitrogen purge was initiated for the duration of the test period, except for the engine firing. The vehicle propellant tanks were then loaded,

and the remainder of the terminal countdown was conducted. Temperature conditioning of the various engine components was accomplished as required, using the facility-supplied engine component conditioning system. Engine components which required temperature conditioning were the thrust chamber, the crossover duct, and main oxidizer valve second-stage actuator. Table V presents the engine purges and thermal conditioning operations during the terminal countdown and immediately following the engine firing.

Test objectives for firings 11C and 11E required a simulated gas generator fuel poppet leak. During pre-fire conditioning for these two firings, the gas generator fuel poppet was opened approximately 30 percent, and propellants were admitted to the gas generator. The valve was opened at approximately $t - 10$ min and closed at $t - 60$ sec.

SECTION IV RESULTS AND DISCUSSION

4.1 TEST SUMMARY

4.1.1 General

Fourteen firings of the Rocketdyne J-2 rocket engine (S/N J-2036-1) were conducted between September 4 and 24, 1968, during test periods J4-1901-09 through J4-1901-11. These firings were in support of the S-IVB/S-V J-2 flight support testing. Testing was accomplished at pressure altitudes ranging from 81,000 to 107,000 ft at engine start utilizing predicted S-IVB interstage/engine temperature conditions as targets for conditioning engine components.

This series of firings consisted of S-IVB restarts (80-min and 6-hr simulated orbital coast times) and one first burn for evaluation of gas generator transient temperature peaks utilizing gas generator oxidizer supply lines of differing internal configuration. Other objectives included evaluation of engine start transients utilizing start conditions which would result from specific in-flight restart-oriented problems.

A leak in the start tank system was simulated by low start tank pressures ranging from 600 to 1000 psia. A gas generator fuel poppet leak was simulated by opening the poppet approximately 30 percent and admitting fuel into the gas generator and turbine exhaust system. Since the S-IVB stage could be modified to allow repressurizing the start tank from an on-board helium source, it was desirable to evaluate start transients using helium for the start tank gas.

Test requirements and specific test results for each firing are summarized in Table VI. Start and shutdown transient operating times for selected engine valves are presented in Table VII. Figure 8 shows engine start conditions for pump inlets and start and helium tanks. The total firing duration for the three test periods was 181.6 sec. Calculated engine performance for the four 32.5-sec duration firings is presented in Table VIII. Performance program methods of calculation are shown in Appendix IV. Specific test objectives and a brief summary of each firing are presented below. The data presented will be those recorded on the digital data acquisition system, except as noted.

4.1.2 Firing J4-1901-09A

4.1.2.1 Objective

The objective was to perform an S-IVB engine restart after a simulated 6-hr orbital coast to evaluate the engine start transient utilizing helium (1200 psia, 50°F) as the start tank pressurant.

4.1.2.2 Results

The programmed 32.5-sec duration firing following a 7.9-sec fuel lead was prematurely terminated at $t_0 + 1.25$ sec because of an error in programming run duration. Test requirements otherwise were satisfied. Temperature histories of thermally conditioned engine components are shown in Fig. 9. Engine start and shutdown transients are shown in Fig. 10. Fuel pump start transient performance is shown in Fig. 11. Engine ambient and combustion chamber pressure histories are shown in Fig. 12. Pressure altitude at engine start was 88,000 ft.

Maximum transient gas generator temperature was 850°F (first peak). Oxidizer dome prime (chamber pressure attains 100 psia) occurred at $t_0 + 1.075$ sec, and initial movement of the second stage of the main oxidizer valve occurred at $t_0 + 1.005$ sec. The propellant utilization valve remained full open as scheduled throughout this firing. Approximately 38 msec of excessive engine vibration (VSC) occurred at oxidizer dome prime.

Failure to attain main-stage operation because of the inadvertent premature termination of the firing partially negated test objectives. However, until engine cutoff signal, engine operation was satisfactory, and apparently, main-stage operation would have been successfully achieved.

4.1.3 Firing J4-1901-09B

4.1.3.1 Objective

The objective was to perform an S-IVB engine restart after a simulated 6-hr orbital coast to evaluate the effects of reduced start tank pressure (1000-psia) on the engine start transient.

4.1.3.2 Results

The firing of 32.6-sec duration following a 7.9-sec fuel lead was conducted, which satisfied test requirements. Temperature histories of thermally conditioned engine components are shown in Fig. 13. Engine start and shutdown transients are shown in Fig. 14. Fuel pump start transient performance is shown in Fig. 15. Engine ambient and combustion chamber pressure histories are shown in Fig. 16. Pressure altitude at engine start was 100,000 ft.

Maximum gas generator transient temperature was 930°F (first peak). Oxidizer dome prime occurred at $t_0 + 1.073$ sec, initial movement of the second stage of the main oxidizer valve occurred at $t_0 + 1.014$ sec, and main-stage operation (chamber pressure attains 550 psia) occurred at $t_0 + 2.659$ sec. The scheduled propellant utilization valve excursion (open to closed) was completed at $t_0 + 14.1$ sec. Approximately 20 msec of excessive engine vibration (VSC) occurred at oxidizer dome prime. Fuel pump stall margin (Fig. 15) was reduced to approximately 550 gpm at 17,000 rpm.

4.1.4 Firing J4-1901-09C

4.1.4.1 Objective

The objective was to perform an S-IVB engine restart after a simulated 80-min orbital coast to evaluate gas generator transient temperature for comparison with firing 08B. Firing 08B utilized an Anaconda oxidizer supply line, S/N 3729063; firing 09C utilized an Anaconda oxidizer supply line, S/N 3726659.

4.1.4.2 Results

The firing of 7.6-sec duration following a 7.9-sec fuel lead was conducted 30 min after firing 09B and satisfied test requirements. Temperature histories of thermally conditioned engine components are shown in Fig. 17. Engine start and shutdown transients are shown in Fig. 18. Fuel pump start transient performance is shown in Fig. 19. Engine

ambient and combustion chamber pressure histories are shown in Fig. 20. Pressure altitude at engine start was 100,000 ft.

Maximum gas generator transient temperatures were 1270°F (first peak) and 1530°F (second peak). Oxidizer dome prime occurred at $t_0 + 0.945$ sec, initial movement of the second stage of the main oxidizer valve occurred at $t_0 + 1.100$ sec, and main-stage operation was attained at $t_0 + 2.056$ sec. The propellant utilization valve remained full open as scheduled throughout this firing.

Test results from firing 08B are similar to results of this firing. A comparison of significant starting conditions is shown below:

Test Number		08B	09C
Fuel Pump Inlet	Pressure, psia	27.3	26.9
	Temperature, °F	-421.3	-421.4
Oxidizer Pump Inlet	Pressure, psia	45.5	45.2
	Temperature, °F	-295.2	-295.1
Start Tank	Pressure, psia	1298	1296
	Temperature, °F	-268	-272
Thrust Chamber Average Temperature at t_0 , °F		-284	-284
Crossover Duct Temperature, °F (TFTD-2, -3, and -8, respectively)		388, 180, and 418	427, 171, and 423

Transient gas generator temperatures were about 70 deg lower on firing 08B, while chamber pressure buildup to main stage required essentially the same time for both firings. These data implied that the gas generator outlet temperature transient is practically the same for identical starting conditions and for the two gas generator oxidizer supply lines tested.

4.1.5 Firing J4-1901-09D

4.1.5.1 Objective

The objective was to perform an S-IVB engine restart after a simulated 6-hr orbital coast to evaluate the effects of reduced start tank pressure (800-psia) on the engine start transient.

4.1.5.2 Results

The firing of 32.6-sec duration following a 7.9-sec fuel lead was conducted, which satisfied test requirements. Temperature histories of thermally conditioned engine components are shown in Fig. 21. Engine start and shutdown transients are shown in Fig. 22. Fuel pump start transient performance is shown in Fig. 23. Engine ambient and combustion chamber pressure histories are shown in Fig. 24. Pressure altitude at engine start was 101,000 ft.

Maximum gas generator transient temperature was 990°F (first peak). Oxidizer dome prime occurred at $t_0 + 1.102$ sec, initial movement of the second stage of the main oxidizer valve occurred at $t_0 + 1.011$ sec, and main-stage operation was attained at $t_0 + 2.741$ sec. The scheduled propellant utilization valve excursion (open to closed) was completed at $t_0 + 13.9$ sec. Approximately 22 msec of excessive engine vibration (VSC) occurred at oxidizer dome prime. Fuel pump stall margin (Fig. 23) was reduced to approximately 250 gpm at 17,000 rpm.

4.1.6 Firing J4-1901-09E

4.1.6.1 Objective

The objective was to perform an S-IVB engine restart after a simulated 80-min orbital coast to evaluate augmented spark igniter operation and gas generator transient temperature with maximum start tank energy for comparison with firing 08D results.

4.1.6.2 Results

The firing of 7.6-sec duration following a 7.9-sec fuel lead was conducted 30 min after firing 09D and satisfied test requirements. Temperature histories of thermally conditioned engine components are shown in Fig. 25. Engine start and shutdown transients are shown in Fig. 26. Fuel pump start transient performance is shown in Fig. 27. Engine ambient and combustion chamber pressure histories are shown in Fig. 28. Pressure altitude at engine start was 100,000 ft.

Ignition was detected in the augmented spark igniter 265 msec after engine start. Maximum gas generator transient temperatures were 1350°F (first peak) and 1660°F (second peak). Oxidizer dome prime occurred at $t_0 + 0.947$ sec, initial movement of the second stage of the main oxidizer valve occurred at $t_0 + 1.114$ sec, and main-stage operation was attained at $t_0 + 2.058$ sec. The propellant utilization valve remained full open as scheduled throughout this firing.

A brief comparison of starting conditions for firings 08D and 09E is shown below:

Test Number		08D	09E
Fuel Pump Inlet	Pressure, psia	41.0	40.7
	Temperature, °F	-421.0	-421.3
Oxidizer Pump Inlet	Pressure, psia	45.0	45.0
	Temperature, °F	-294.7	-294.5
Start Tank	Pressure, psia	1298	1300
	Temperature, °F	-265	-266
Thrust Chamber Average Temperature at t_0 , °F		-339	-334
Crossover Duct Temperature, °F (TFTD-2, -3, and -8, respectively)		422, 175, and 431	430, 171, and 424

Test results from firing 08D only partially agree with results of this firing. Transient gas generator temperatures were 150°F (first peak) and 200°F (second peak) higher on firing 09E. Chamber pressure buildup to main stage required essentially the same time for both firings.

4.1.7 Firing J4-1901-09F

4.1.7.1 Objective

The objective was to perform an S-IVB engine restart after a simulated 6-hr orbital coast to evaluate the effects of reduced start tank pressure (600-psia) on the engine start transient.

4.1.7.2 Results

The firing of 0.68-sec duration following a 7.9-sec fuel lead was prematurely terminated by the fuel pump stall approach monitor. Test requirements were satisfied. Temperature histories of thermally conditioned engine components are shown in Fig. 29. Engine start and shutdown transients are shown in Fig. 30. Fuel pump start transient performance is shown in Fig. 31. Engine ambient and combustion chamber pressure histories are shown in Fig. 32. Pressure altitude at engine start was 102,000 ft.

Engine cutoff signal was automatically initiated by the fuel pump stall approach monitor. This is a safety cutoff (not part of the engine safety cutoff system) which will terminate a firing if fuel flow is below 3300 ± 175 gpm for any 55-msec period after $t_0 + 0.585$ sec. At the time of cutoff signal, fuel flow was approximately 3360 gpm. Fuel pump stall margin was approximately 1300 gpm at cutoff signal.

4.1.8 Firing J4-1901-10A

4.1.8.1 Objective

The objective was to perform an S-IVB engine restart after a simulated 6-hr orbital coast to evaluate gas generator transient peaks.

4.1.8.2 Results

The firing of 7.6-sec duration following a 7.9-sec fuel lead satisfied the test requirements. Temperature histories of thermally conditioned engine components are shown in Fig. 33. Engine start and shutdown transients are shown in Fig. 34. Fuel pump start transient performance is shown in Fig. 35. Engine ambient and combustion chamber pressures experienced during the firing are shown in Fig. 36. Pressure altitude at engine start was 81,000 ft.

Maximum gas generator first peak temperature was 660°F, whereas no second peak was obtained. Oxidizer dome prime occurred at $t_0 + 1.091$ sec. The engine experienced approximately 23 msec of excessive vibration (VSC) during oxidizer dome prime. Main oxidizer valve initial second-stage movement occurred at $t_0 + 0.996$ sec, and main-stage operation was attained at $t_0 + 3.158$ sec. The propellant utilization valve remained in the open position as scheduled for the duration of the firing.

Comparison of start conditions for this firing and firing J4-1901-06A is shown below:

Test Number		06A	10A
Fuel Pump Inlet	Pressure, psia	27.2	26.6
	Temperature, °F	-421.3	-421.5
Oxidizer Pump Inlet	Pressure, psia	33.7	33.6
	Temperature, °F	-295.4	-295.1
Start Tank	Pressure, psia	1258	1248
	Temperature, °F	-143	-140
Thrust Chamber Average Temperature at t_0 , °F		-367	-366
Crossover Duct Temperature, °F (TFTD-2, -3, and -8, respectively)		-109, -76, and -90	-105, -73, and -86

It should be noted that for these two firings, the gas generator valve oxidizer poppet delay time was lengthened to 150_{-0}^{+5} msec (140 msec is the nominal delay). Firing 06A utilized an Avica gas generator supply line, whereas firing 10A utilized an Anaconda supply line. Gas generator outlet temperature first peak on firing 06A was 790°F higher than on firing 10A. However, oxidizer dome prime and main-stage operation were attained at essentially the same times on both firings.

4.1.9 Firing J4-1901-10B

4.1.9.1 Objective

The objective was to perform an S-IVB engine restart after a simulated 6-hr orbital coast to evaluate the engine start transient utilizing helium (1200 psia, 50°F) as the start tank pressurant.

4.1.9.2 Results

The firing of 7.6-sec duration following a 7.9-sec fuel lead was successfully accomplished, and all test objectives were met. Temperature histories of thermally conditioned engine components are shown in Fig. 37. Engine start and shutdown transients are shown in Fig. 38. Fuel pump start transient performance is shown in Fig. 39. Engine ambient and combustion chamber pressures experienced during the firing are shown in Fig. 40. Pressure altitude at engine start was 100,000 ft.

Start transient data for this firing were normal and generally consistent with firings utilizing hydrogen at the same pressure level as a start tank pressurant. Gas generator initial peak temperature was 740°F; no second peak was experienced. Oxidizer dome prime occurred at $t_0 + 1.117$ sec; main-stage operation was obtained at $t_0 + 3.055$ sec. Initial main oxidizer valve second-stage movement occurred at $t_0 + 1.010$ sec. Approximately 28 msec of excessive engine vibration (VSC) occurred during oxidizer dome prime. The propellant utilization valve remained open as scheduled for the duration of the firing. The remaining firings of this test period were cancelled because of an augmented spark igniter ignition detect probe failure.

4.1.10 Firing J4-1901-11A

4.1.10.1 Objective

The objective was to perform an S-IVB engine first burn to evaluate gas generator temperature transient using an Avica (S/N 045) gas generator oxidizer supply line.

4.1.10.2 Results

The firing of 32.6-sec duration following a 3.0-sec fuel lead was successfully accomplished, and all objectives were met. Temperature histories of thermally conditioned engine components are shown in Fig. 41. Engine start and shutdown transients are shown in Fig. 42. Fuel pump start transient performance is shown in Fig. 43. Engine ambient and combustion chamber pressures experienced during the firing are shown in Fig. 44. Pressure altitude at engine start was 84,000 ft.

Maximum gas generator transient temperature was 1810°F (first peak). Oxidizer dome prime occurred at $t_0 + 0.986$ sec, initial main oxidizer valve second-stage movement occurred at $t_0 + 1.046$ sec, and main-stage operation was attained at $t_0 + 1.885$ sec. The scheduled propellant utilization valve excursion from null to closed was completed at $t_0 + 11.3$ sec.

4.1.11 Firing J4-1901-11B

4.1.11.1 Objective

The objective was to perform an S-IVB engine restart after a simulated 80-min orbital coast to evaluate gas generator temperature transients with minimum fuel pump inlet pressure.

4.1.11.2 Results

The firing of 7.6-sec duration following a 7.9-sec fuel lead was conducted 30 min after firing 11A, and all objectives were met. Temperature histories of thermally conditioned engine components are shown in Fig. 45. Engine start and shutdown transients are shown in Fig. 46. Fuel pump start transient performance is shown in Fig. 47. Engine ambient and combustion chamber pressures experienced during the firings are shown in Fig. 48. Pressure altitude at engine start was 101,000 ft.

Gas generator first and second peak temperatures were 1870 and 1920°F, respectively. Oxidizer dome prime occurred at $t_0 + 0.948$ sec, main oxidizer valve initial second-stage movement occurred at $t_0 + 1.074$ sec, and main-stage operation was attained at $t_0 + 2.012$ sec. Approximately 8 msec of excessive engine vibration occurred at oxidizer dome prime. The propellant utilization valve remained in the open position as scheduled for the firing duration.

Comparison of significant start conditions for firings 09C and 11B is shown below:

Test Number		09C	11B
Fuel Pump Inlet	Pressure, psia	26.9	27.1
	Temperature, °F	-421.4	-420.8
Oxidizer Pump Inlet	Pressure, psia	45.2	45.2
	Temperature, °F	-295.1	-295.1
Start Tank	Pressure, psia	1296	1308
	Temperature, °F	-272	-267
Thrust Chamber Average Temperature at t_0 , °F		-284	-261
Crossover Duct Temperature, °F (TFTD-2, -3, and -8, respectively)		427, 171, and 423	391, 165, and 432
Gas Generator Oxidizer Supply Line		Anaconda	Avica

4.1.12 Firing J4-1901-11C

4.1.12.1 Objective

The objective was to perform an S-IVB engine restart with a simulated gas generator fuel poppet leak.

4.1.12.2 Results

The firing of 32.6-sec duration following an 8.0-sec fuel lead was successfully accomplished, and the test objective was met. Temperature histories of thermally conditioned engine components are shown in Fig. 49. Engine start and shutdown transients are shown in Fig. 50. Fuel pump start transient performance is shown in Fig. 51. Engine ambient and combustion chamber pressures experienced during the firing are shown in Fig. 52. Pressure altitude at engine start was 99,000 ft.

Gas generator first peak temperature was 1480°F with no second peak occurring. Oxidizer dome prime occurred at $t_0 + 1.068$ sec, initial main oxidizer valve second-stage movement occurred at $t_0 + 0.995$ sec, and main-stage operation was attained at $t_0 + 2.916$ sec.

Approximately 11 msec of excessive engine vibration was experienced during oxidizer dome prime. The propellant utilization valve excursion from the open to closed position was completed as scheduled at $t_0 + 11.8$ sec.

4.1.13 Firing J4-1901-11D

4.1.13.1 Objective

The objective was to perform an S-IVB engine restart after a simulated 80-min orbital coast to evaluate gas generator temperature transients with maximum fuel pump inlet pressure and other conditions identical to firing 11B.

4.1.13.2 Results

The firing of 7.6-sec duration following an 8.0-sec fuel lead was successfully accomplished approximately 30 min after firing 11C. Temperature histories of thermally conditioned engine components are shown in Fig. 53. Engine start and shutdown transients are shown in Fig. 54. Fuel pump start transient performance is shown in Fig. 55. Engine ambient and combustion chamber pressures experienced during the firing are shown in Fig. 56. Pressure altitude at engine start was 106,000 ft.

Maximum gas generator temperature first and second peaks were 1800 and 1840°F, respectively. Oxidizer dome prime occurred at $t_0 + 0.950$ sec. Initial main oxidizer valve second-stage movement occurred at $t_0 + 1.110$ sec, and main-stage operation was attained at $t_0 + 2.019$ sec. The propellant utilization valve remained in the open position as scheduled for the duration of the firing.

Starting conditions for firings 11B and 11D compare closely except for fuel pump inlet pressure. Fuel pump inlet pressure was maximum (41 psia) on firing 11D and minimum (27 psia) on firing 11B. Gas generator outlet temperatures (initial peaks) were essentially the same. The second peak temperature of 1920°F on firing 11B was only 80°F higher than that of firing 11D. Oxidizer dome prime time for the two firings was essentially the same. The time required to attain main-stage operation differed by only 25 msec.

4.1.14 Firing J4-1901-11E

4.1.14.1 Objective

The objective was to perform a partial transition S-IVB engine restart after a simulated 6-hr orbital coast to evaluate engine start transient with a simulated gas generator fuel poppet leak.

4.1.14.2 Results

The firing of 2.6-sec duration following a 7.9-sec fuel lead was successfully accomplished. Oxidizer and fuel pump inlet temperatures were too warm by 0.8 and 0.4°F, respectively; otherwise test requirements were met. Temperature histories of thermally conditioned engine components are shown in Fig. 57. Engine start and shutdown transients are shown in Fig. 58. Fuel pump start transient performance is shown in Fig. 59. Engine ambient and combustion chamber pressure experienced during the firing is shown in Fig. 60. Pressure altitude at engine start was 106,000 ft.

Gas generator first peak temperature was 230°F with no second peak occurring. Oxidizer dome prime occurred at $t_0 + 1.162$ sec, and main oxidizer valve second-stage initial movement occurred at $t_0 + 1.009$ sec. Approximately 19 msec of excessive engine vibration (VSC) was experienced during oxidizer dome prime. The propellant utilization valve remained in the open position as scheduled for the duration of the firing.

The oxidizer turbine bypass valve exhibited an abnormal opening sequence after shutdown on this firing. After a delay of 350 msec, the valve opened approximately 35 percent, then returned to the closed position. At 13.26 sec after shutdown, the valve started to open, requiring a 3.17-sec opening time.

4.1.15 Firing J4-1901-11F

4.1.15.1 Objective

The objective was to perform a partial S-IVB engine restart after a simulated 6-hr orbital coast to evaluate the effects of reduced start tank pressure (600-psia) on engine start transients.

4.1.15.2 Results

The firing (programmed to terminate at main-stage signal) was prematurely terminated at $t_0 + 1.26$ sec by the fuel pump stall approach monitor. Test requirements were satisfied except for oxidizer pump inlet conditions which were 3.4 psi high and 1.5°F warm. Temperature histories of thermally conditioned engine components are shown in Fig. 61. Engine start and shutdown transients are shown in Fig. 62. Fuel pump start transient performance is shown in Fig. 63. Engine ambient and combustion chamber pressures experienced during the firing are shown in Fig. 64. Pressure altitude at engine start was 107,000 ft.

Gas generator initial peak temperature was 1560°F with no second peak occurring. Oxidizer dome prime occurred at $t_0 + 1.156$ sec, and initial main oxidizer valve second-stage movement occurred at $t_0 + 1.017$ sec. The propellant utilization valve remained in the open position as scheduled for the duration of the firing.

Prior to test period 10, the stall approach monitor cutoff level was reduced to approximately 3000 ± 175 gpm. At engine cutoff signal, fuel flow and stall margin were 3360 and 700 gpm, respectively.

4.2 ENGINE OPERATION WITH REDUCED START TANK PRESSURE

Start tank pressures of 600, 600, 800, and 1000 psia at engine start were utilized for firings 11F, 09F, 09D, and 09B, respectively. The effects of the reduced start tank pressures on pump speeds, fuel pump stall margin during start tank discharge, and oxidizer dome prime time are shown in Fig. 65. Fuel pump start transient performance of firings using 600-, 800-, and 1000-psia start tank pressures are compared in Fig. 66.

Oxidizer pump peak speed resulting from start tank discharge and the corresponding fuel pump speed were increased by 21 and 29 percent, respectively, as start tank pressure was increased from 600 to 1000 psia at engine start. Oxidizer dome prime time was decreased from $t_0 + 1.156$ sec (600-psia start tank pressure) to $t_0 + 1.073$ sec (1000-psia start tank pressure). Although test period 11 used an Avica gas generator oxidizer supply line and test period 09 used an Anaconda line, investigation of data from Ref. 2 showed that these different line configurations had little effect on oxidizer dome prime time.

As shown in Fig. 66, fuel pump stall margin was affected in both the low- and high-speed regions. Fuel pump stall margin during start tank discharge was increased from 1200 to 1700 gpm as start tank pressure was increased from 600 to 1000 psia. High-speed stall margins of 250 and 550 gpm were noted for start tank pressures of 800 and 1000 psia, respectively. Both firings utilizing a 600-psia start tank pressure (firings 09F and 11F) were terminated by the stall approach monitor because established safe engine operating limits were exceeded.

4.3 POST-TEST INSPECTION

The augmented spark igniter ignition detect probe was replaced after test period 09 for reliability. The probe was again replaced after test period 10 because of a probe element failure.

Post-test 10 leak checks revealed fuel pump turbine seal leakage to be excessive. The fuel pump primary, secondary, and turbine seals were subsequently replaced.

SECTION V SUMMARY OF RESULTS

The results of the 14 firings of the Rocketdyne J-2 rocket engine conducted between September 4 and 24, 1968, in Test Cell (J-4) are summarized as follows:

1. Two engine firings were successfully accomplished utilizing start tank pressures of 800 and 1000 psia. Two firings with a 600-psia start tank pressure were terminated prematurely since established safe engine operating limits were exceeded.
2. Test results indicate that gas generator oxidizer supply line internal configuration differences produced initial peak temperatures which differed between 500 and 760°F. No other significant effects were noted.
3. Two firings were successfully accomplished using (1200-psia, +50°F) helium as a start tank pressurant. Start transient data appeared to be normal and consistent with firings utilizing hydrogen, at the same pressure level, as a start tank pressurant.
4. Two firings were successfully conducted utilizing a simulated gas generator fuel poppet leak as an additional test requirement. As a consequence, extremely cold crossover duct, turbine, and thrust chamber temperatures resulted in comparatively slow gas generator and main chamber pressure buildup.

REFERENCES

1. Dublin, M., Sissenwine, N., and Wexler, H. U. S. Standard Atmosphere, 1962. December 1962.
2. Simpson, J. N. and Pillow, C. E. "Flight Support Testing of the J-2 Rocket Engine in Propulsion Engine Test Cell (J-4) (Tests J4-1901-07 through J4-1901-08)." AEDC-TR-68-264 January 1969.

3. "J-2 Rocket Engine, Technical Manual Engine Data." R-3825-1, August 1965.
4. Test Facilities Handbook (7th Edition). "Large Rocket Facility, Vol. 3." Arnold Engineering Development Center, July 1968.

APPENDIXES

- I. ILLUSTRATIONS**
- II. TABLES**
- III. INSTRUMENTATION**
- IV. METHODS OF CALCULATION (PERFORMANCE PROGRAM)**

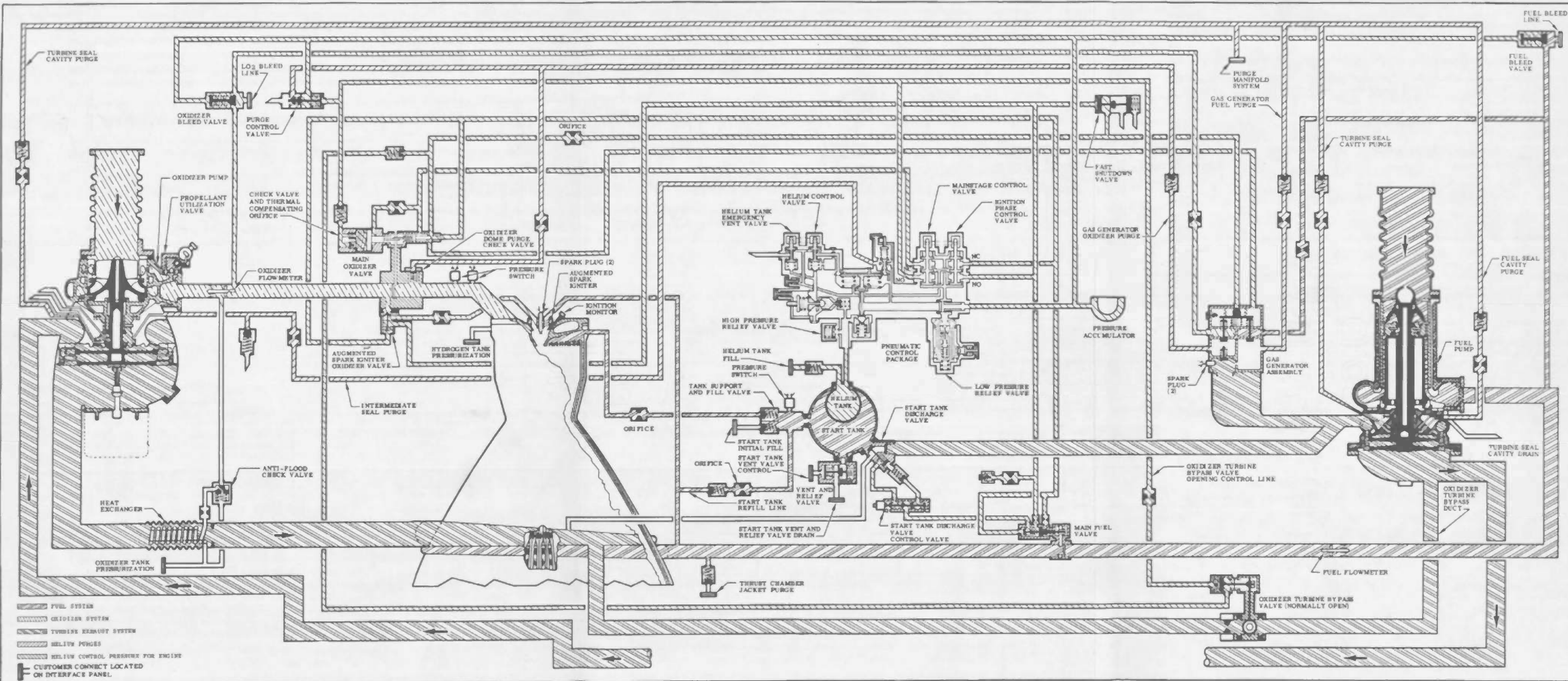

Fig. 15 Mechanical Schematic of the J-2 Engine

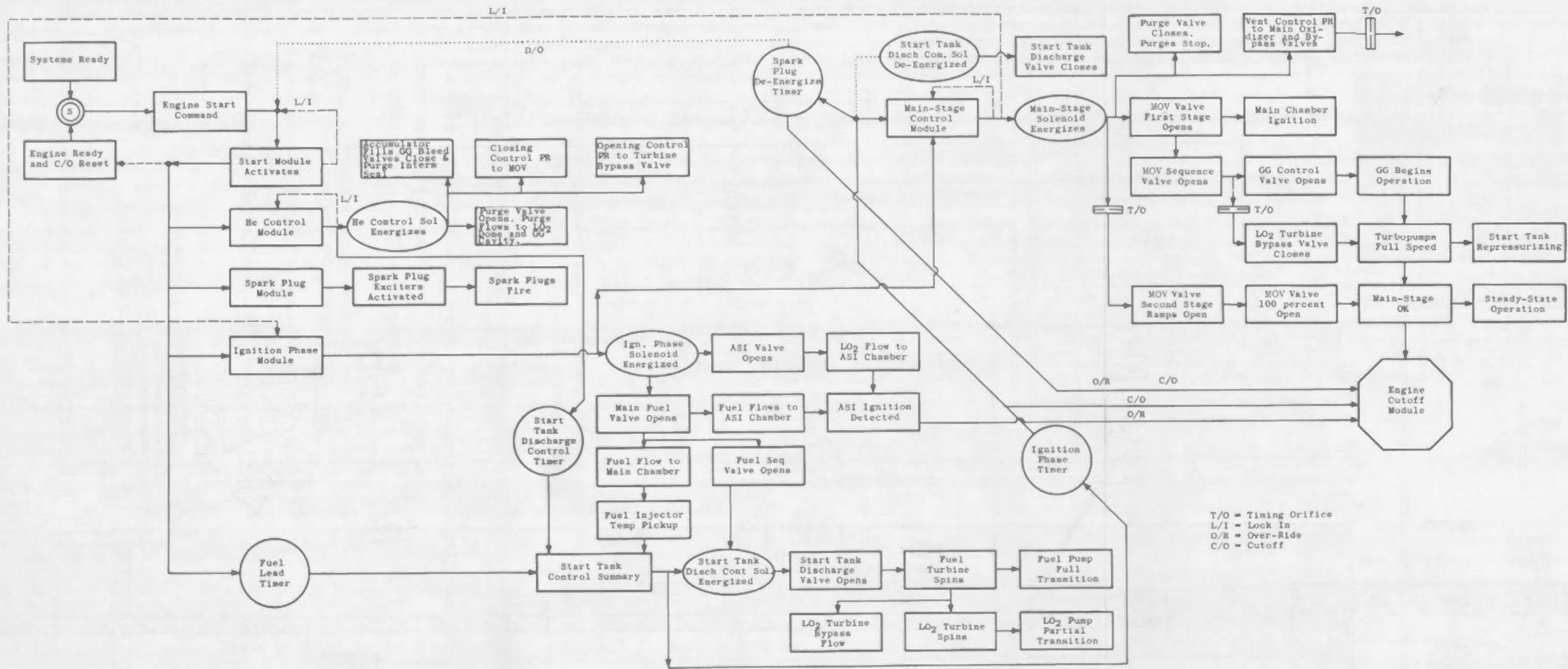

Fig. 16 Logic Schematic of the J-2 Engine Start

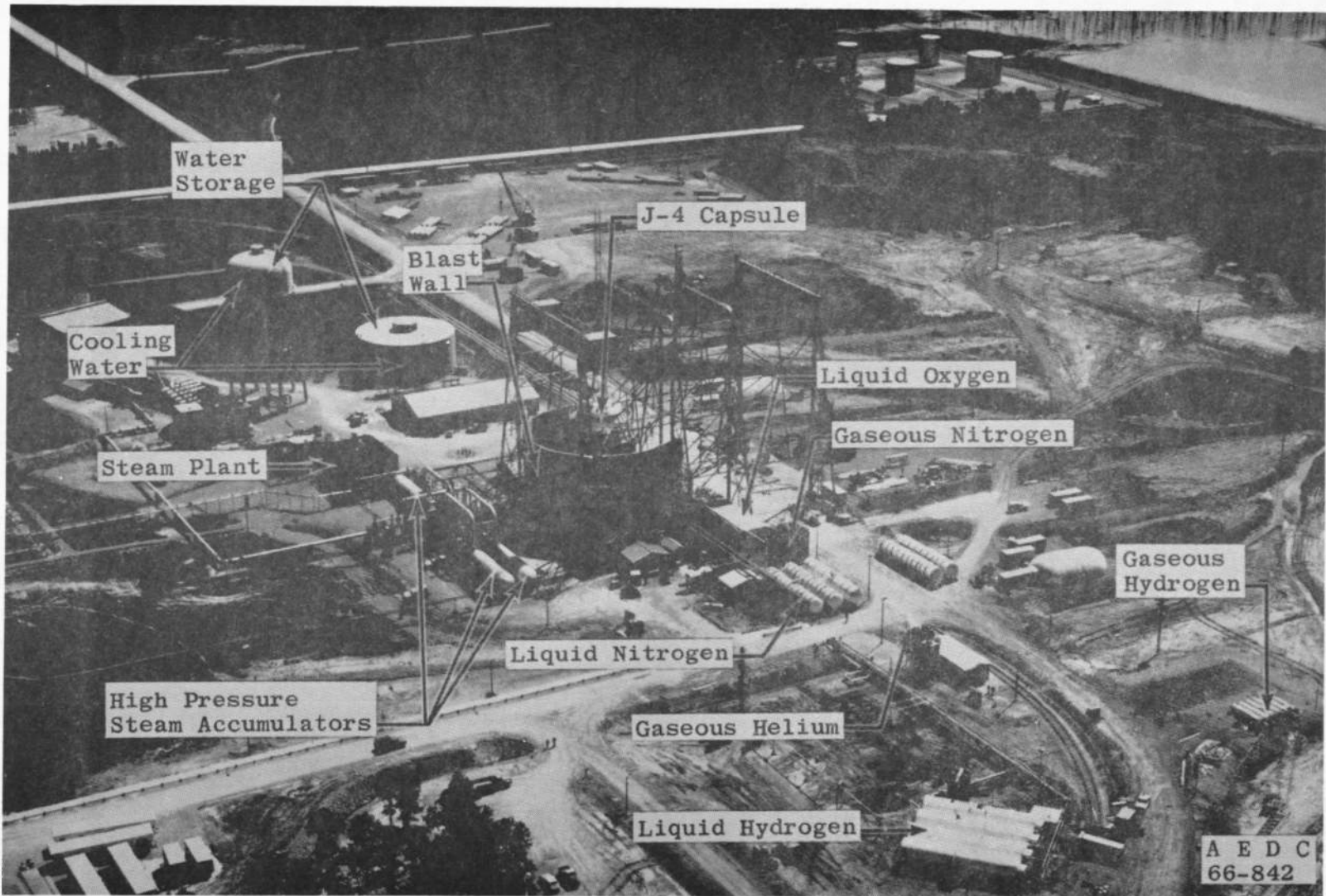

Fig. 1 Test Cell J-4 Complex

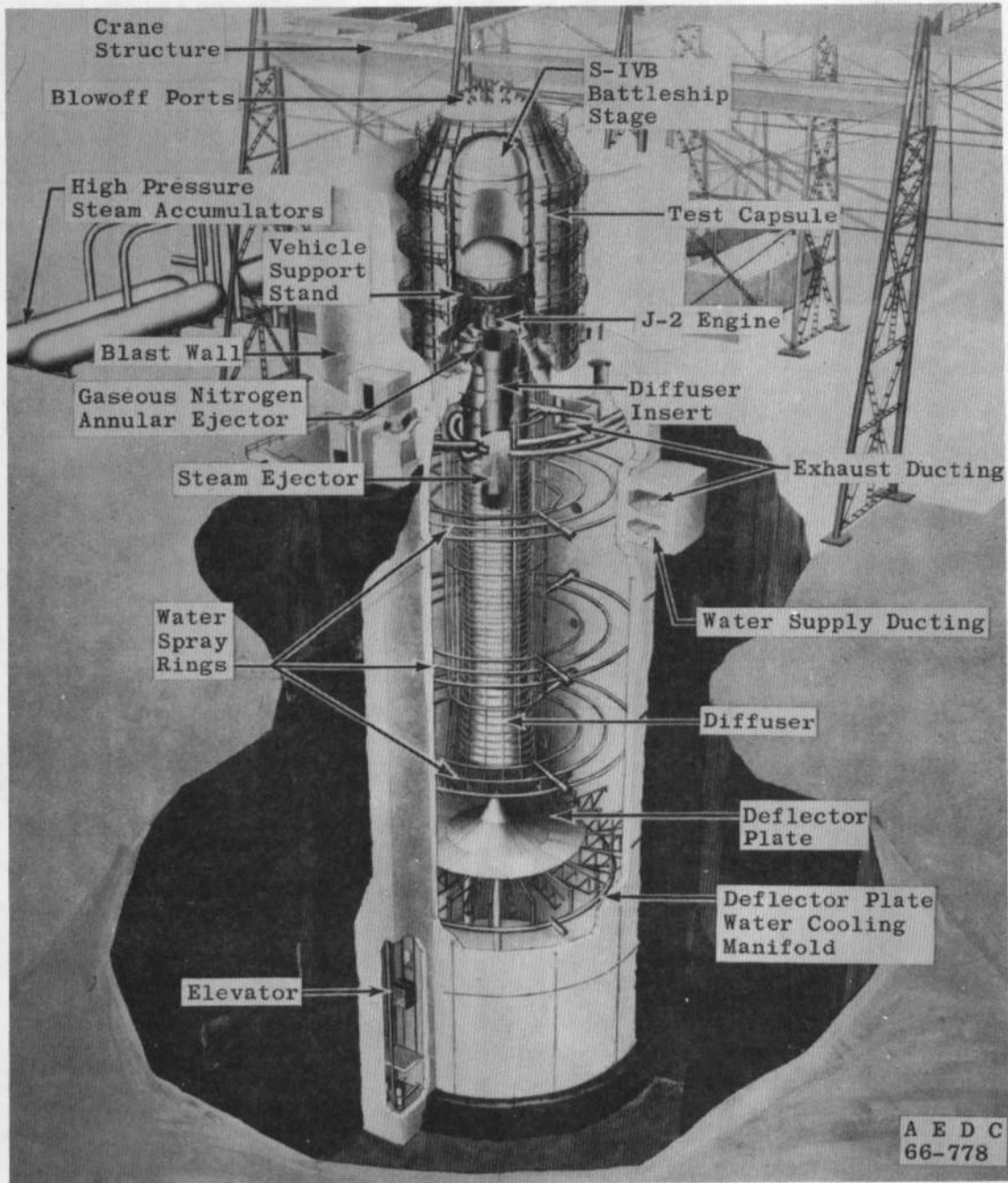
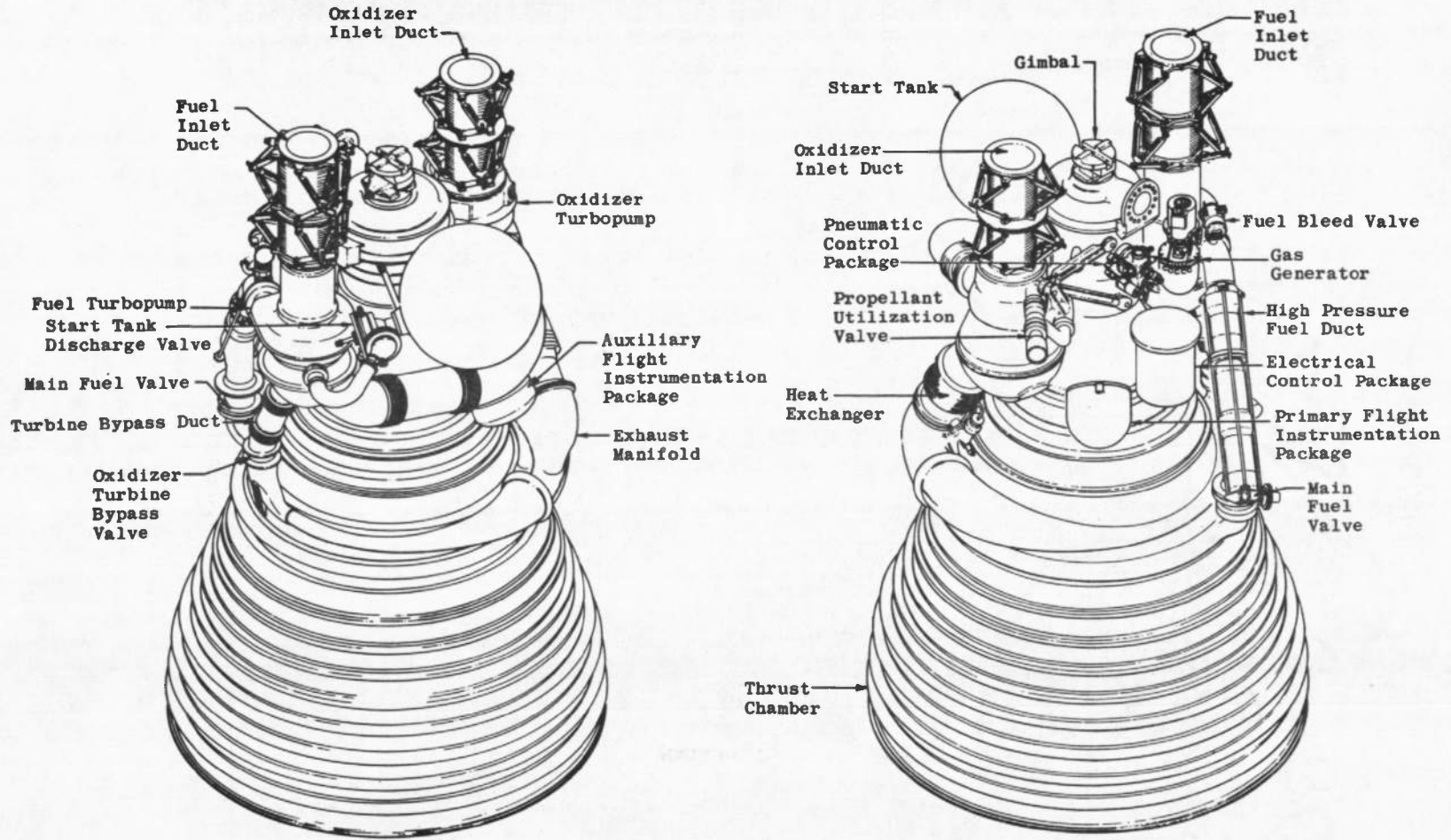
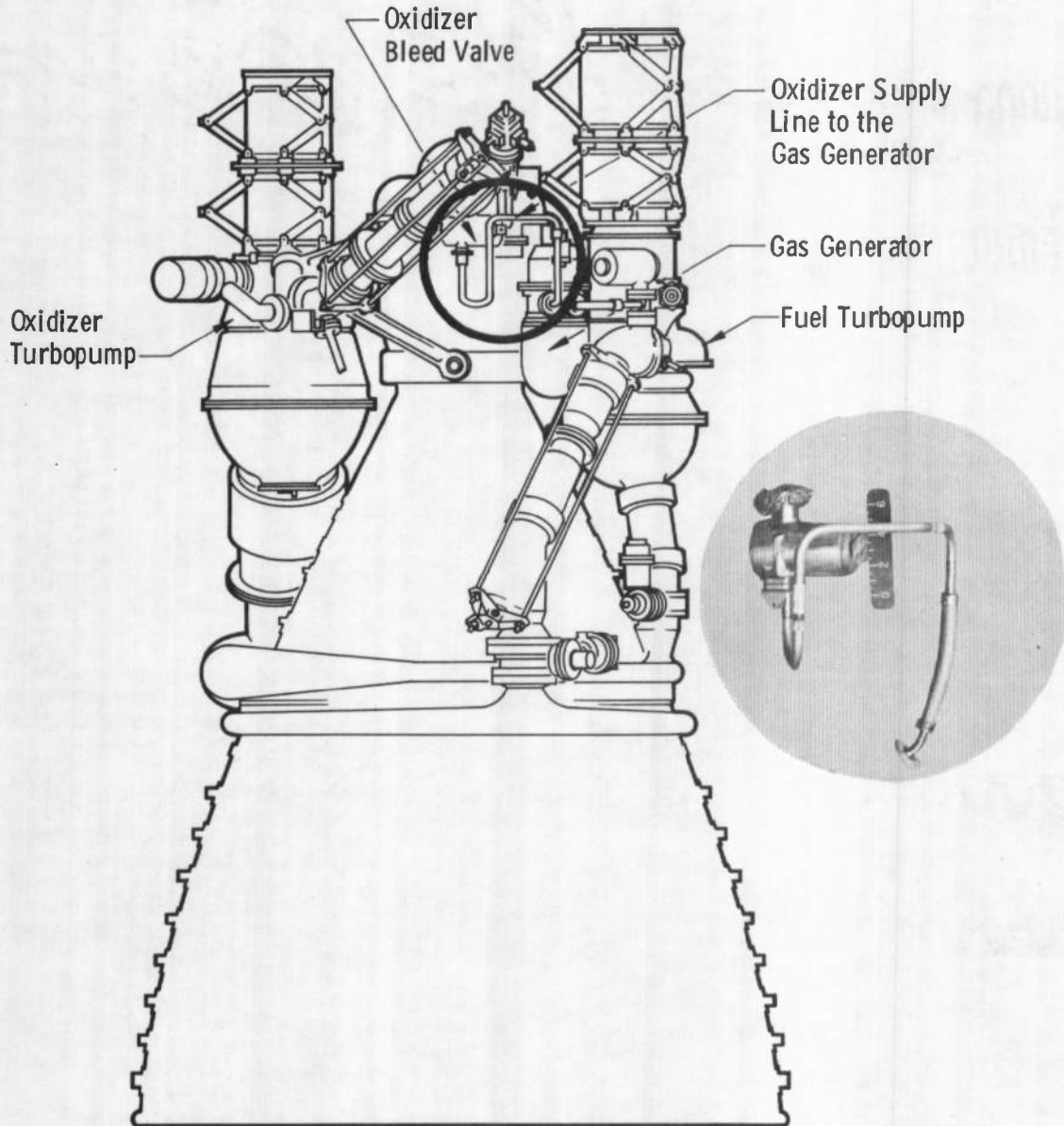

Fig. 2 Test Cell J-4, Artist's Conception



a. Major Engine Components
 Fig. 3 Engine Details



b. Gas Generator Oxidizer Supply Line Detail
Fig. 3 Continued

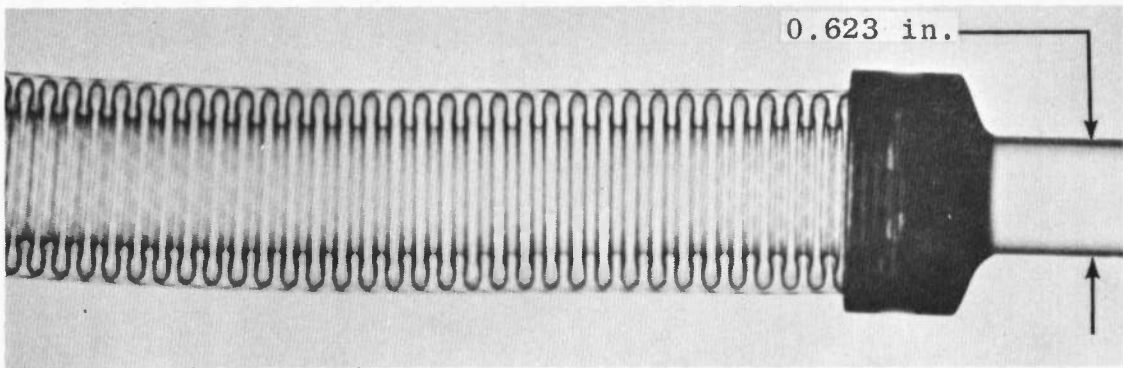

c. Gas Generator Oxidizer Supply Line Assembly, Anaconda (P/N 408710, S/N 3729063)

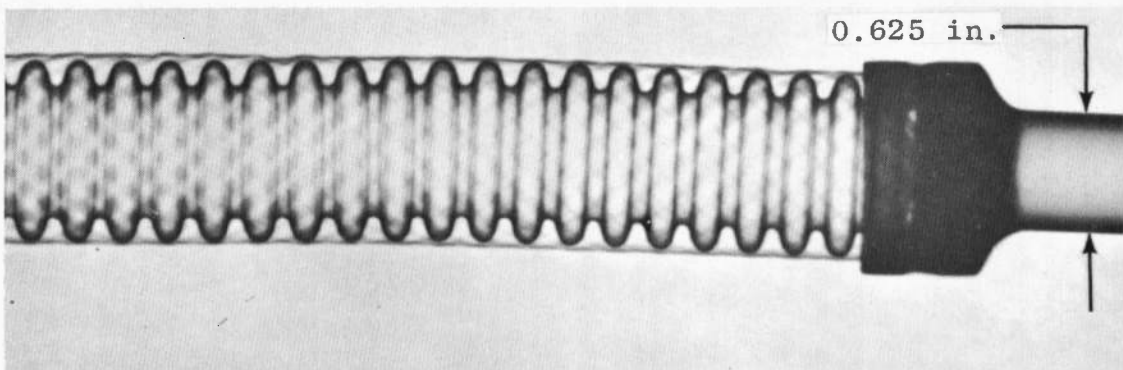

d. Gas Generator Oxidizer Supply Line Assembly, Avica (P/N NA5-260113, S/N 045)

Fig. 3 Concluded

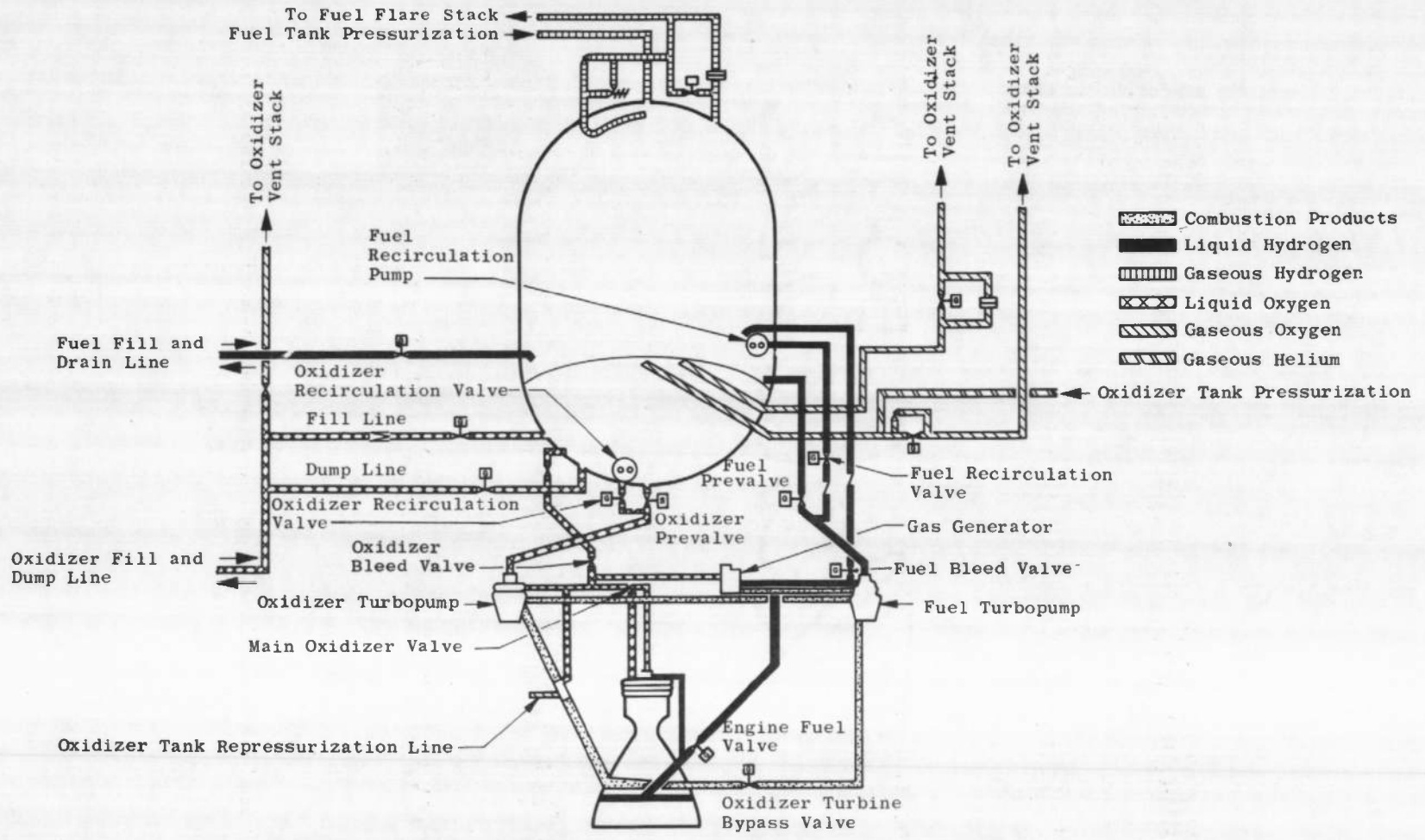
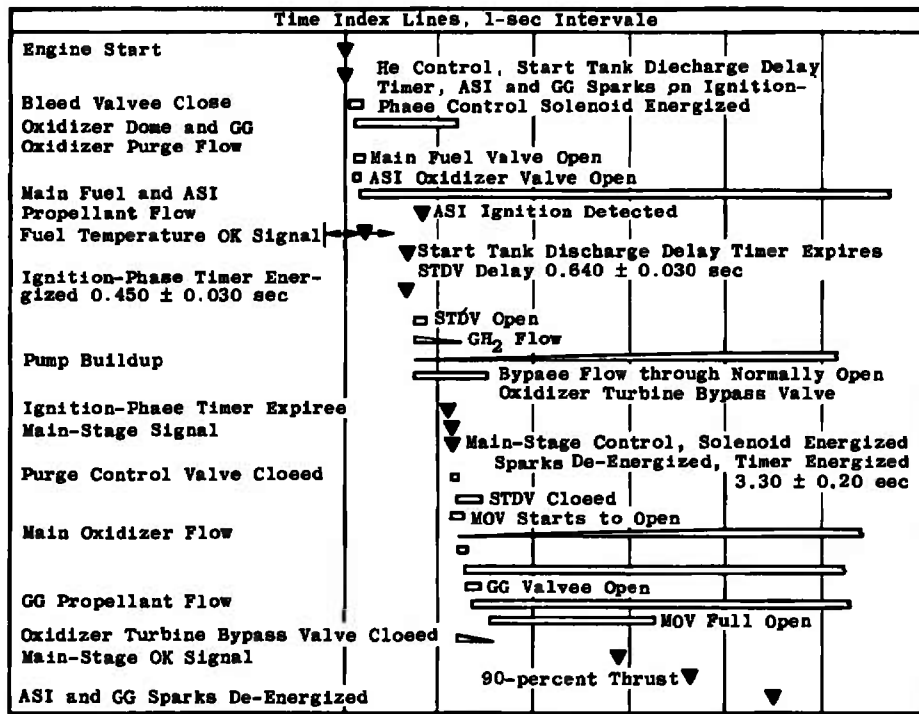
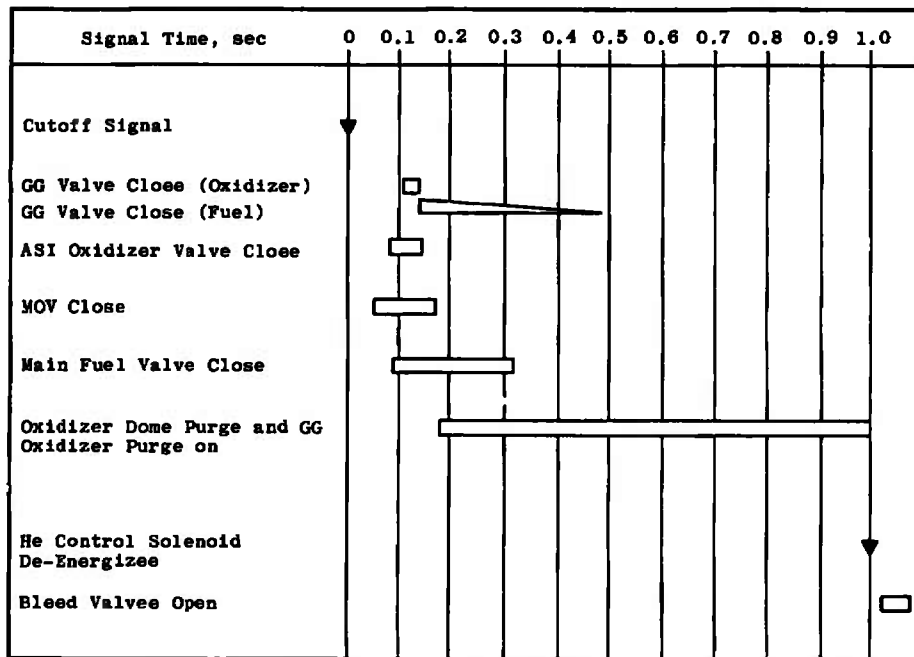

Fig. 4 S-IVB Battleship Stage/J-2 Engine Schematic



a. Start Sequence



b. Shutdown Sequence

Fig. 7 Engine Start and Shutdown Sequence

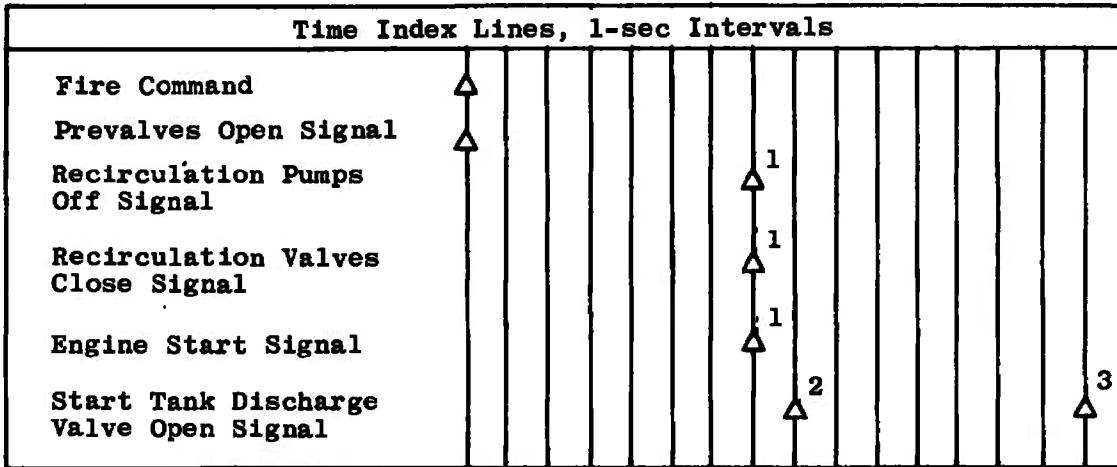

¹Nominal Occurrence Time (Function of Prevalves Opening Time)

²One-sec Fuel Lead (S-II/S-V and S-IVB/S-IB)

³Eight-sec Fuel Lead (S-IVB/S-V and S-IB Orbital Restart)

c. Normal Logic Start Sequence

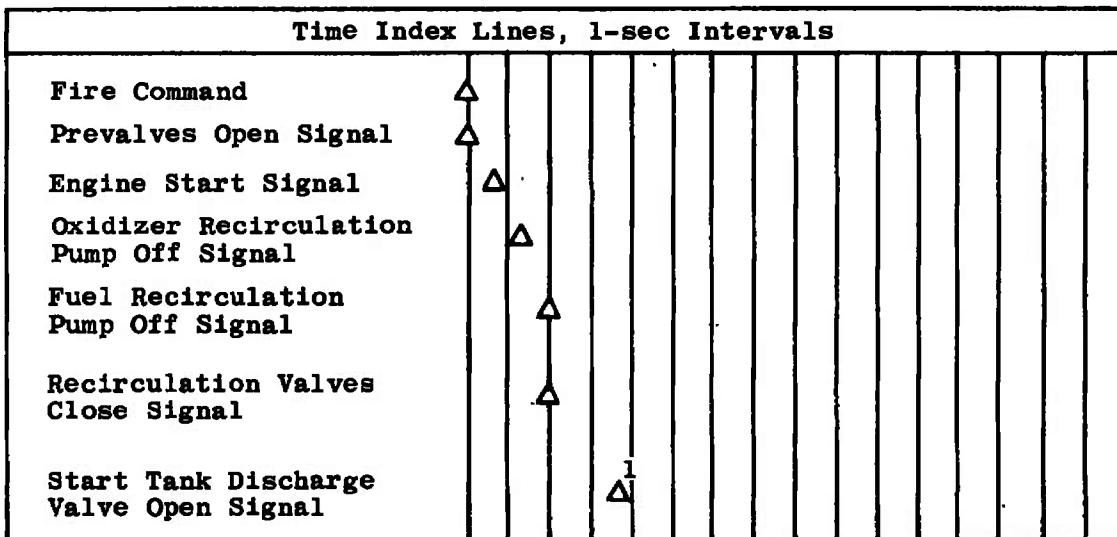

¹Three-sec Fuel Lead (S-IVB/S-V First Burn)

d. Auxiliary Logic Start Sequence

Fig. 7 Concluded

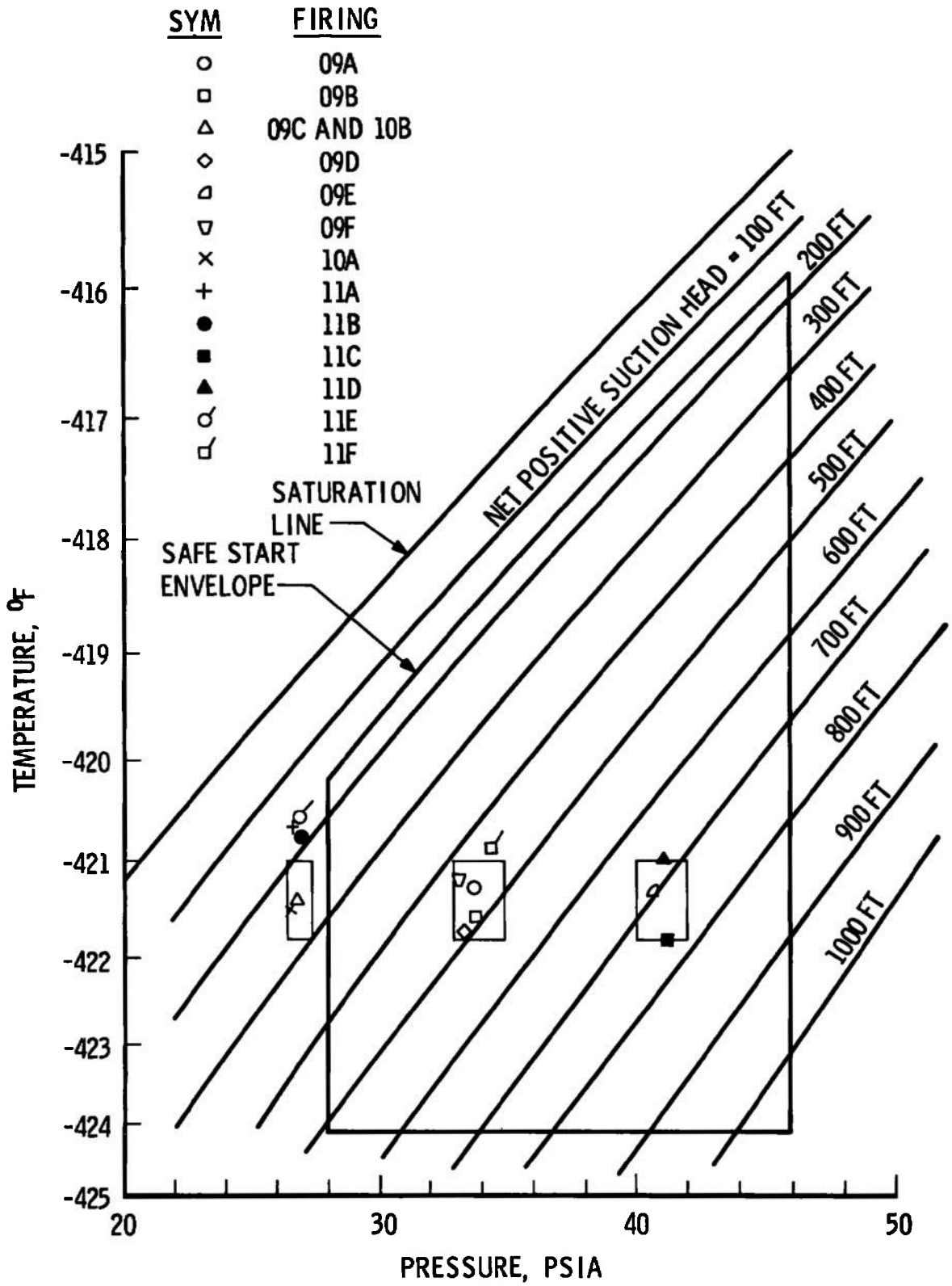

a. Fuel Pump Inlet

Fig. 8 Engine Start Conditions for the Pump Inlets, Start Tank, and Helium Tank

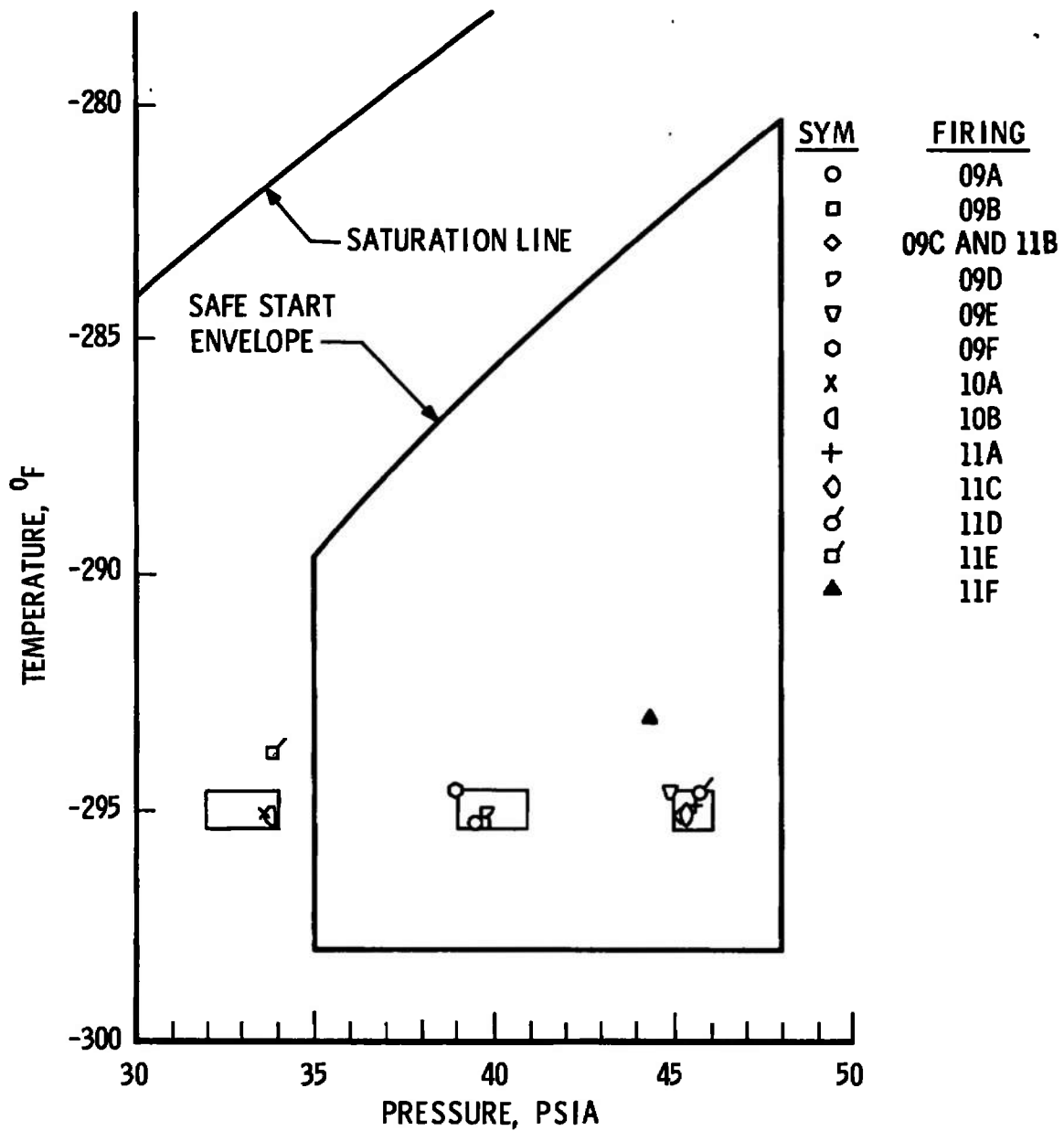

b. Oxidizer Pump Inlet
 Fig. 8 Continued

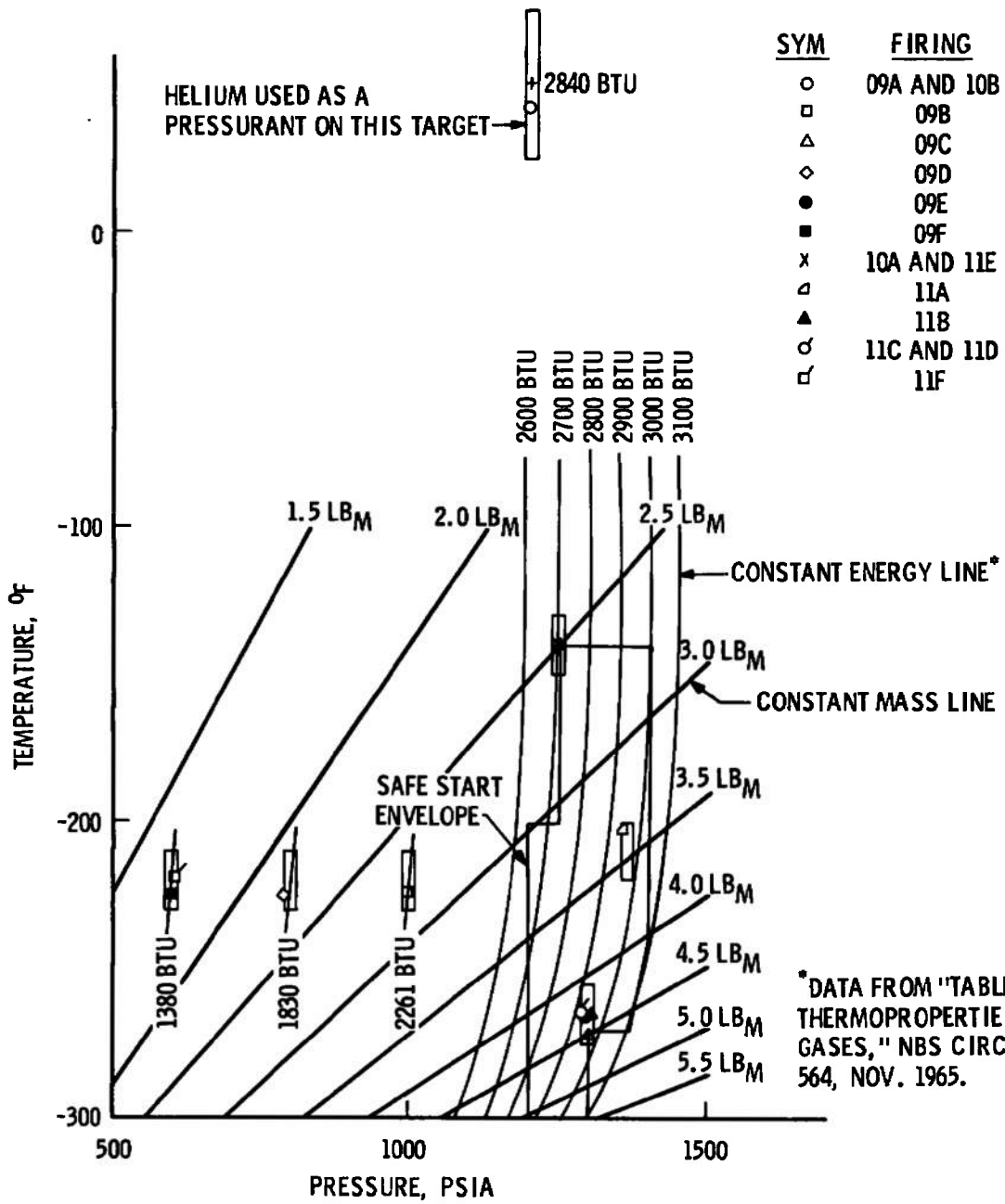

c. Start Tank
Fig. 8 Continued

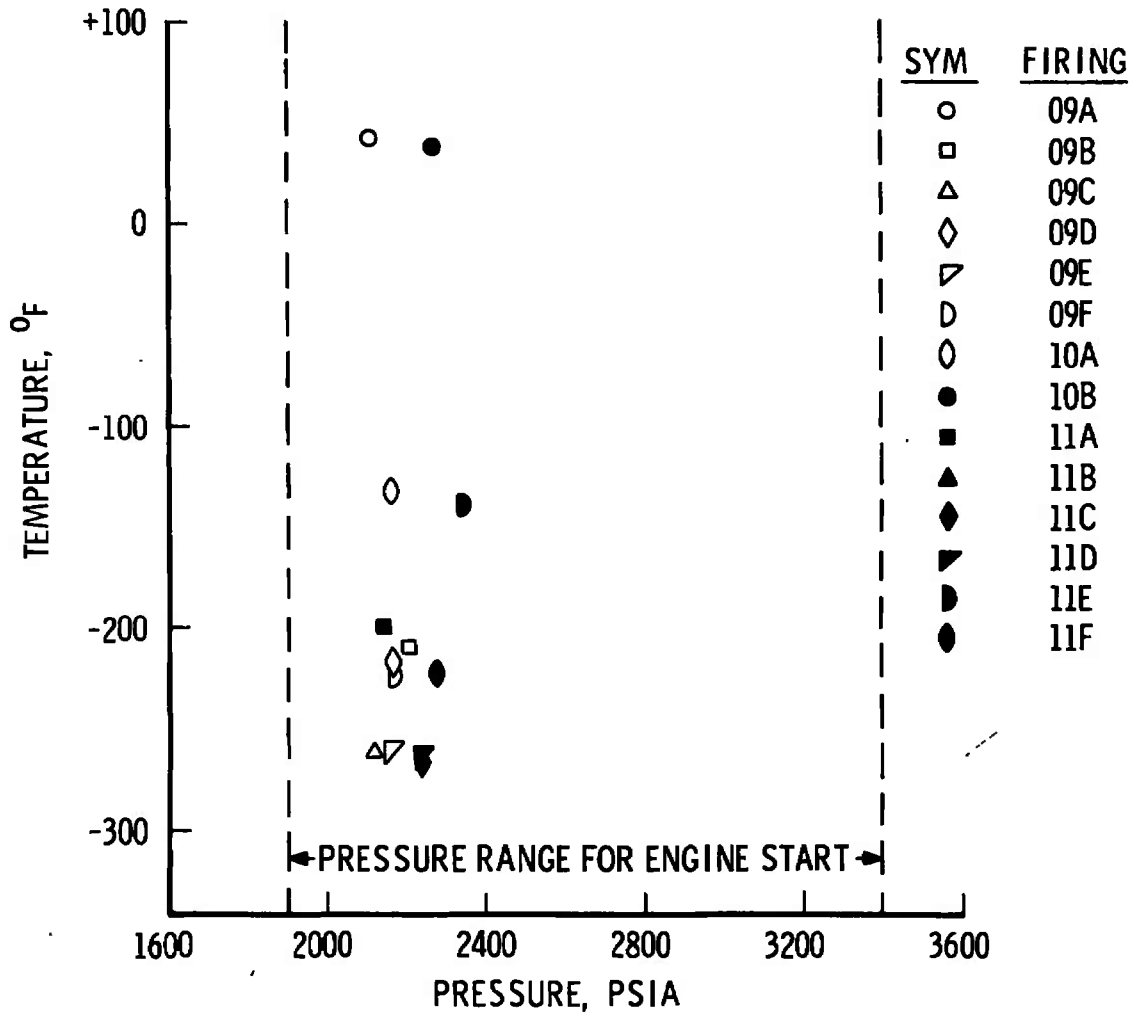

d. Helium Tank
Fig. 8 Concluded

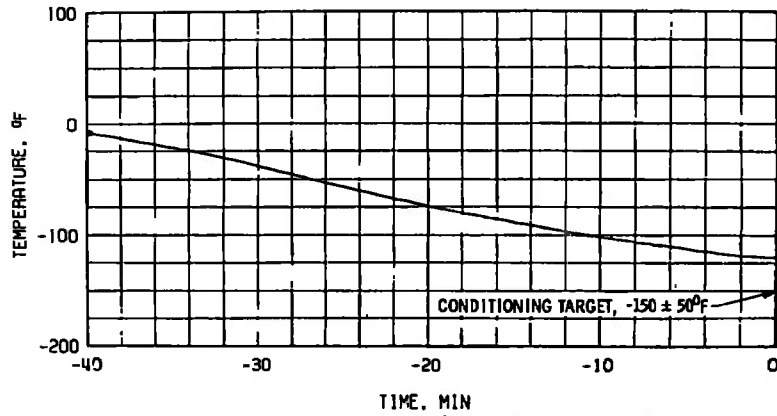

a. Main Oxidizer Valve Second-Stage Actuator, TSOVC-1

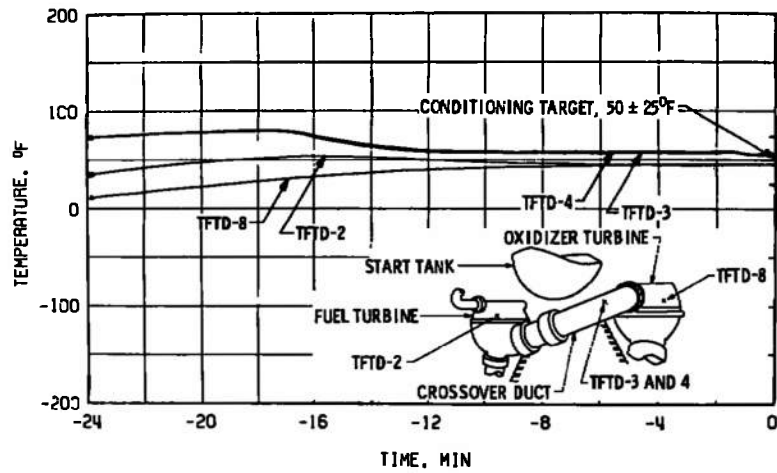

b. Crossover Duct, TFTD

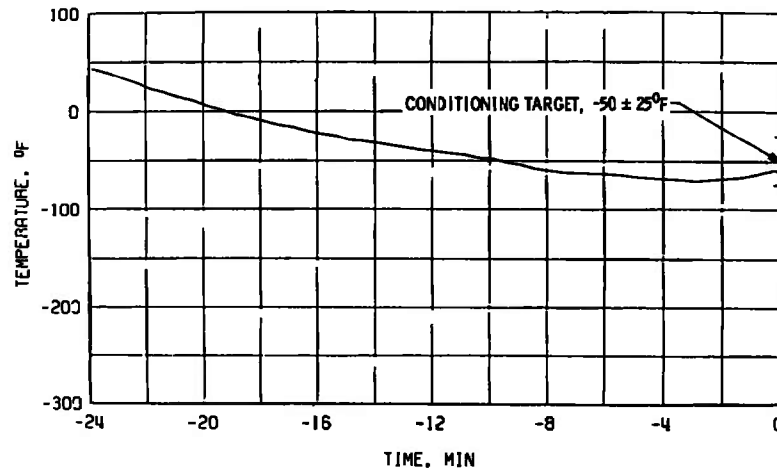

c. Thrust Chamber Throat, TTC-1P

Fig. 9 Thermal Conditioning History of Engine Components, Firing 09A

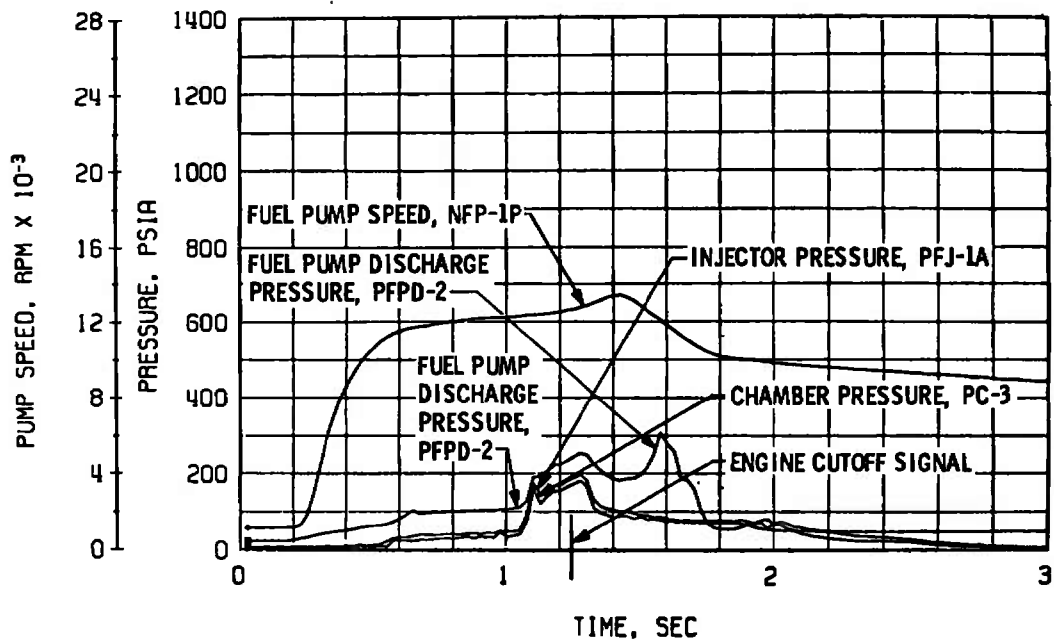

a. Thrust Chamber Fuel System, Start and Shutdown

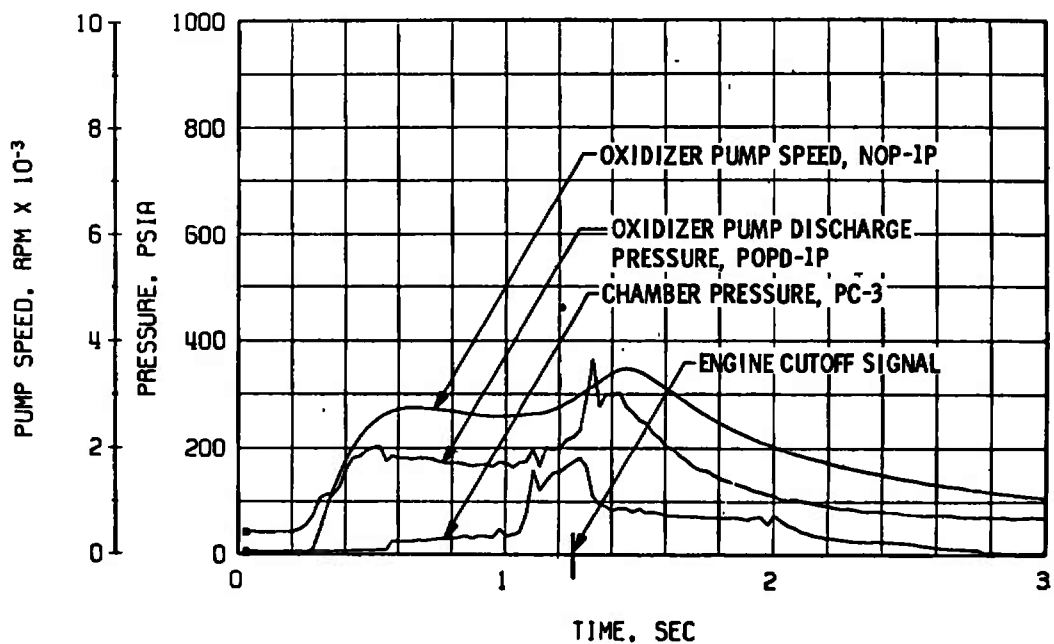

b. Thrust Chamber Oxidizer System, Start and Shutdown

Fig. 10 Engine Transient Operation, Firing 09A

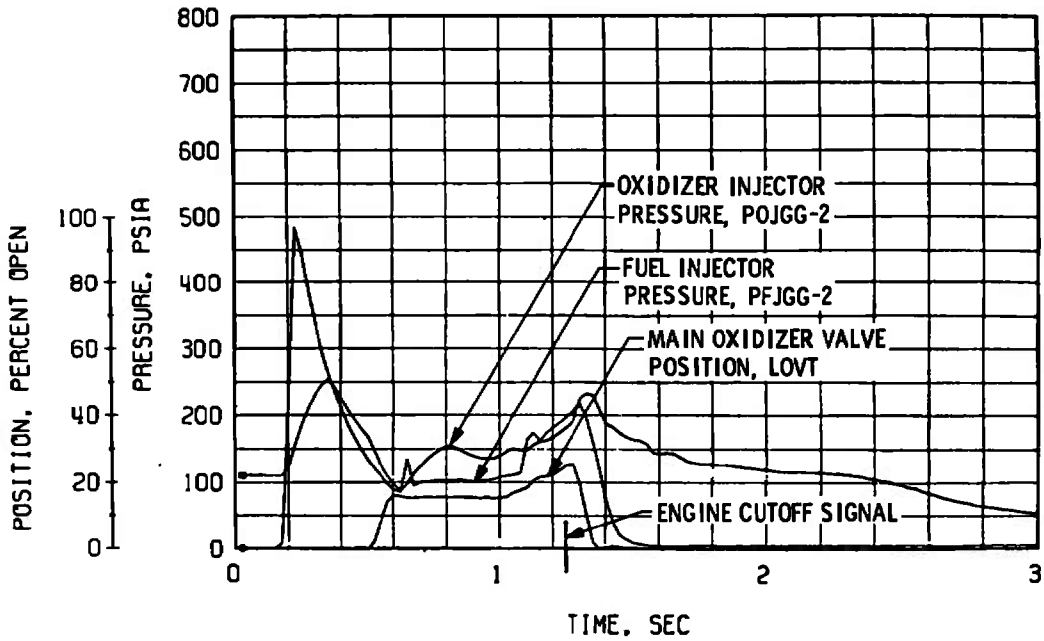

c. Gas Generator Injector Pressures and Main Oxidizer Valve Position, Start and Shutdown

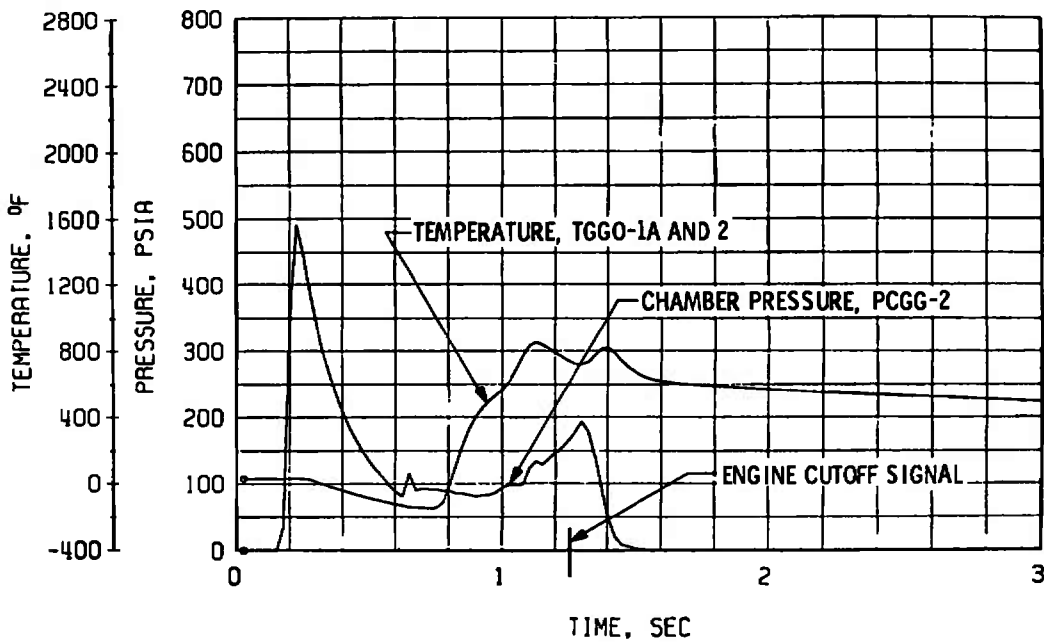

d. Gas Generator Chamber Pressure and Temperature, Start and Shutdown

Fig. 10 Concluded

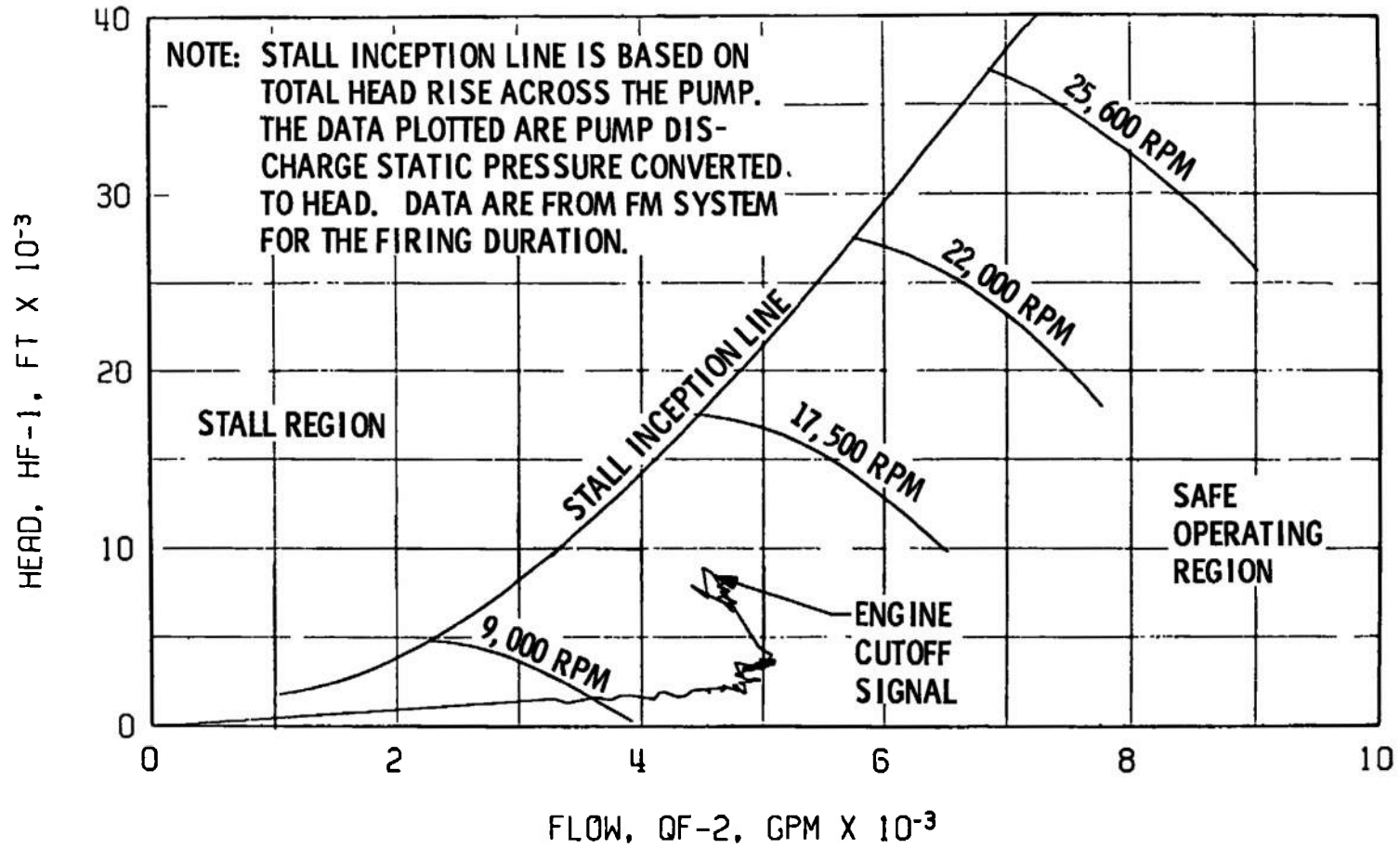

Fig. 11 Fuel Pump Start Transient Performance, Firing 09A

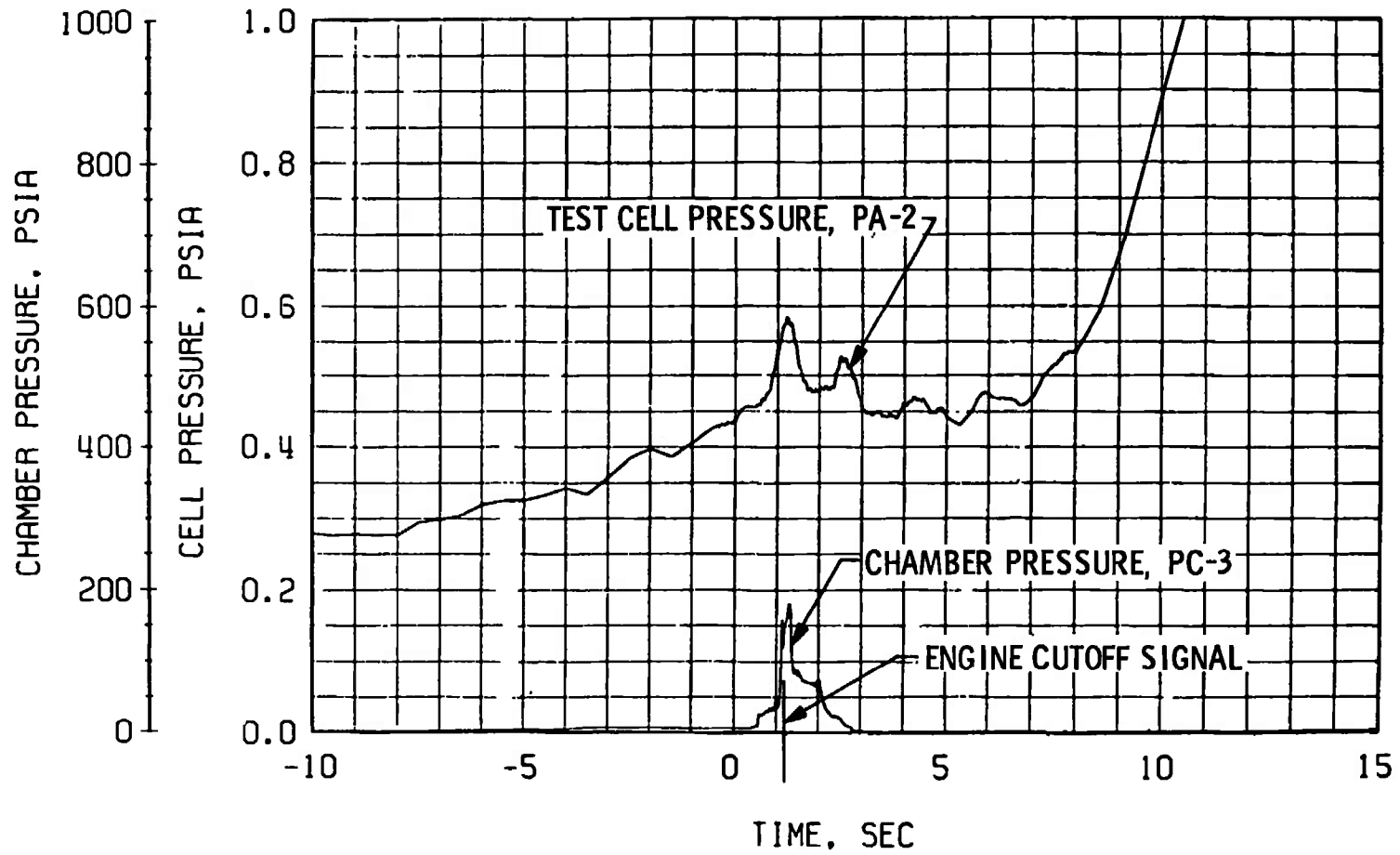
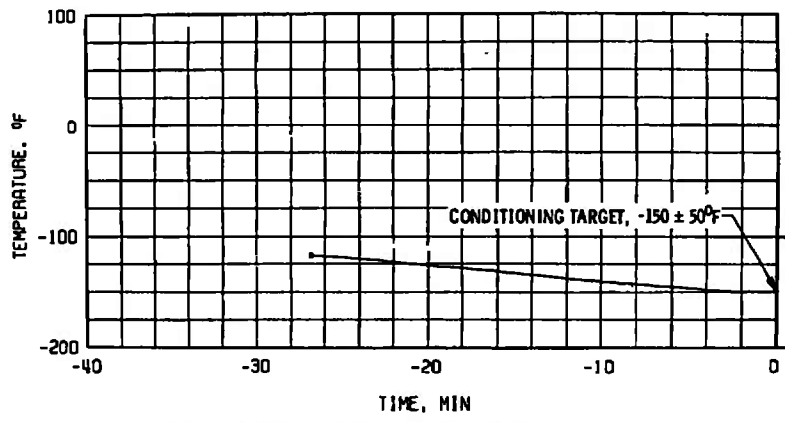
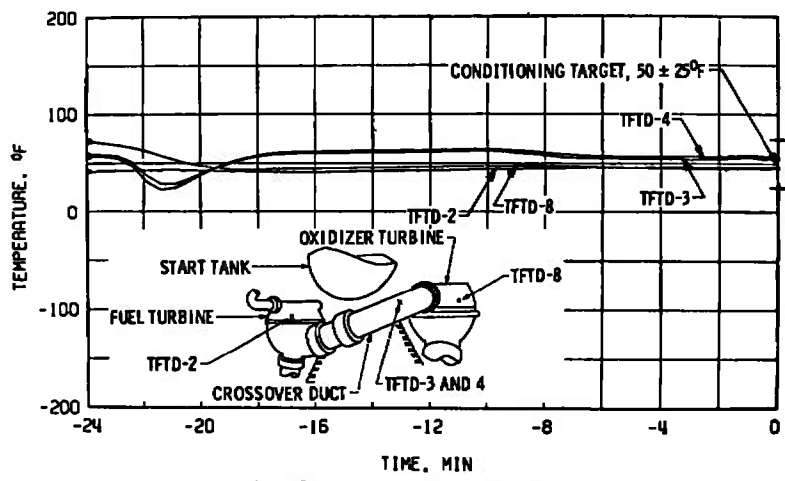

Fig. 12 Engine Ambient and Combustion Chamber Pressure, Firing 09A



a. Main Oxidizer Valve Second-Stage Actuator, TSOVC-1



b. Crossover Duct, TFTD

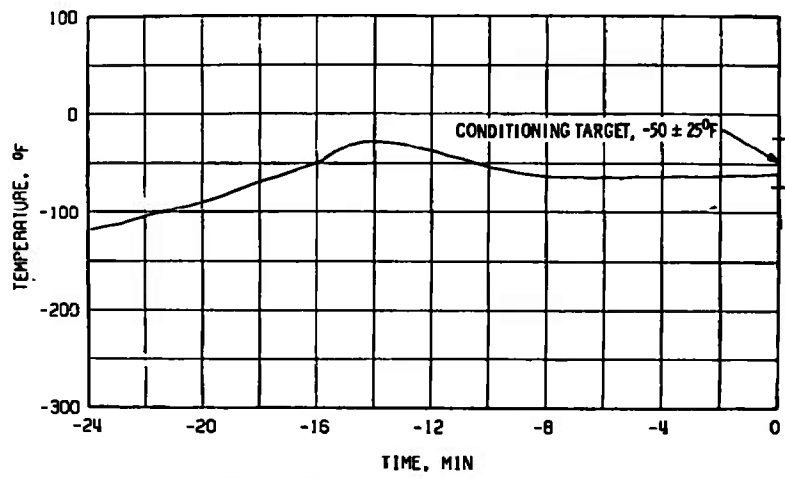

c. Thrust Chamber Throat, TTC-1P

Fig. 13 Thermal Conditioning History of Engine Components, Firing 09B

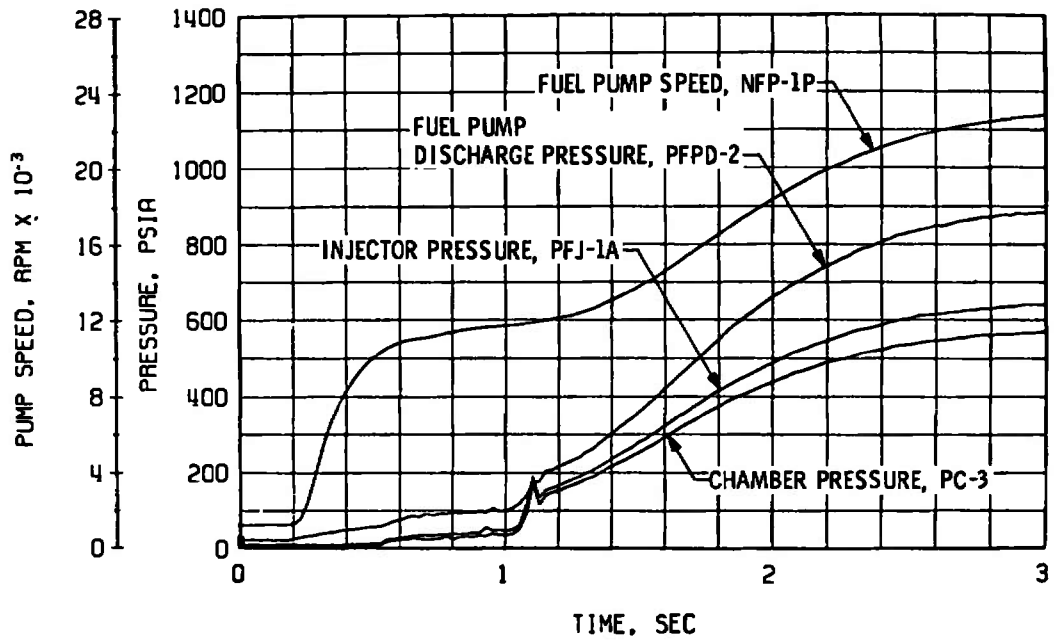

a. Thrust Chamber Fuel System, Start

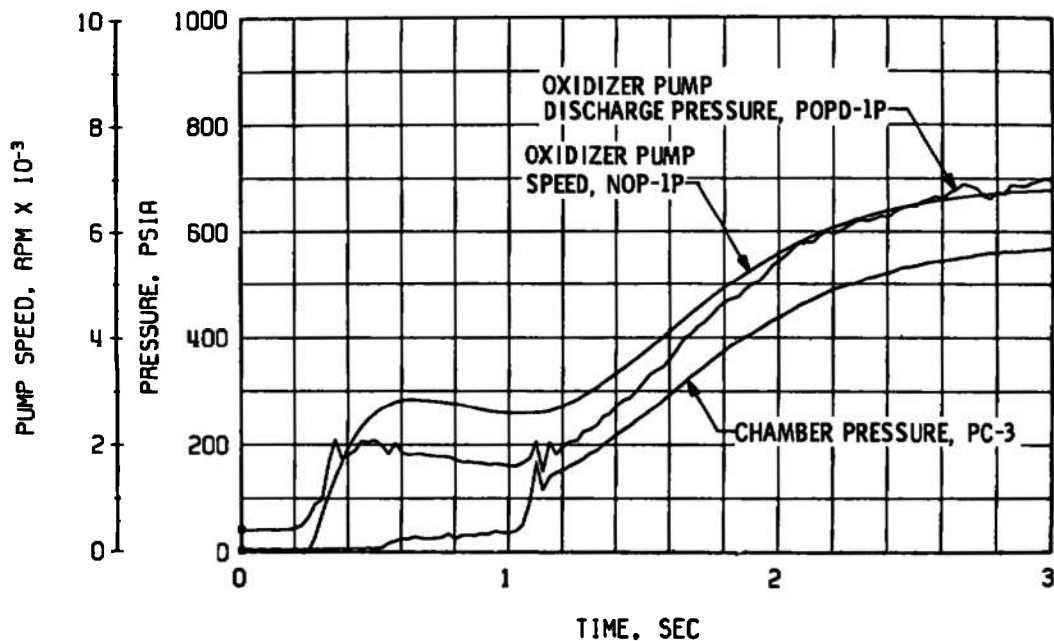

b. Thrust Chamber Oxidizer System, Start

Fig. 14 Engine Transient Operation, Firing 09B

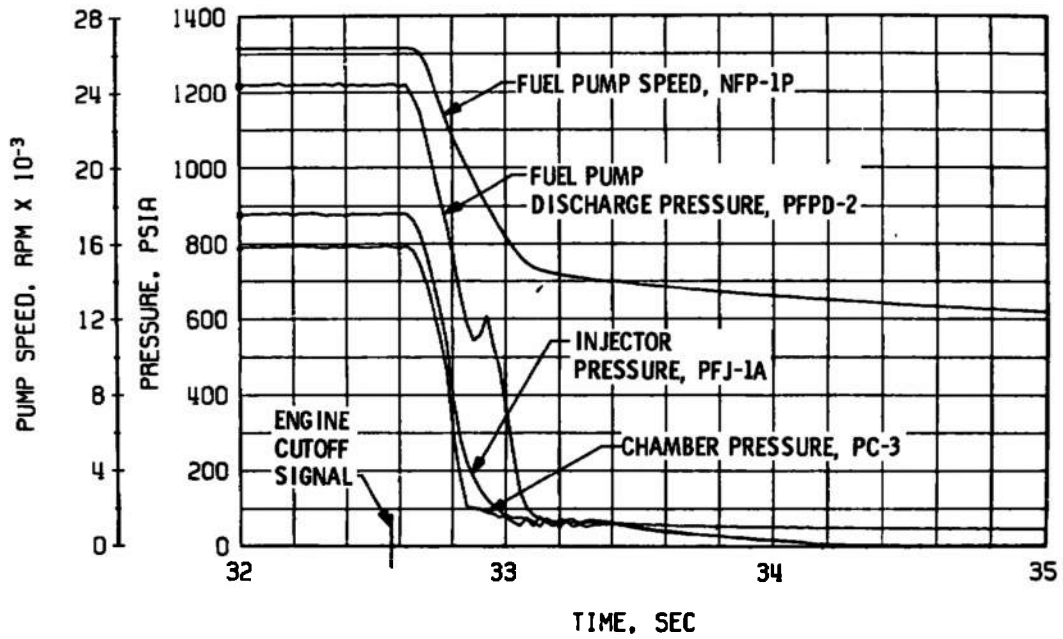

c. Thrust Chamber Fuel System, Shutdown

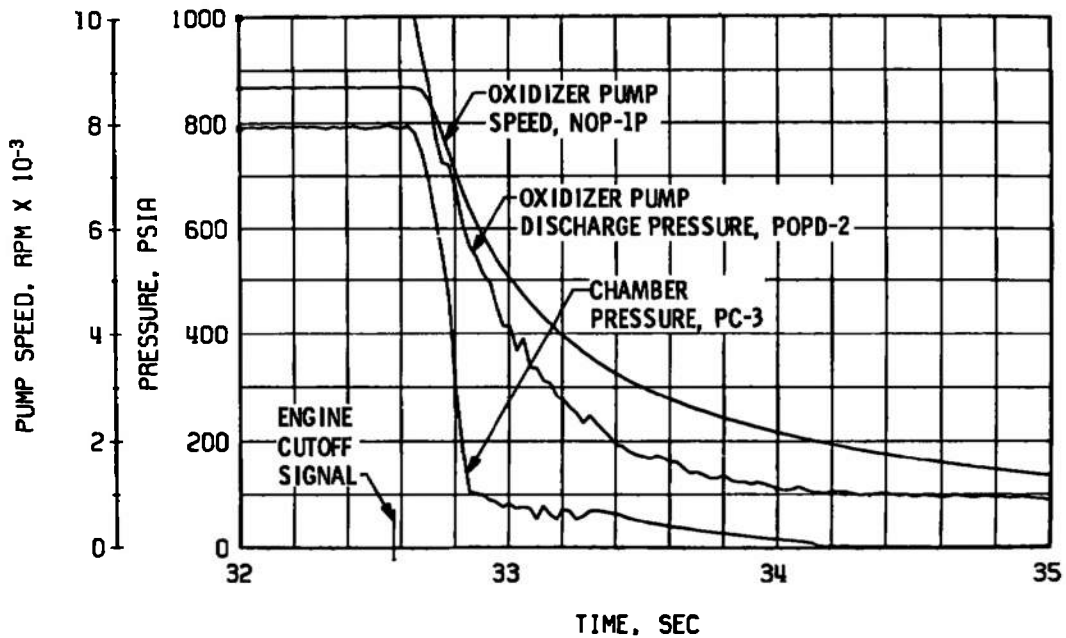

d. Thrust Chamber Oxidizer System, Shutdown

Fig. 14 Continued

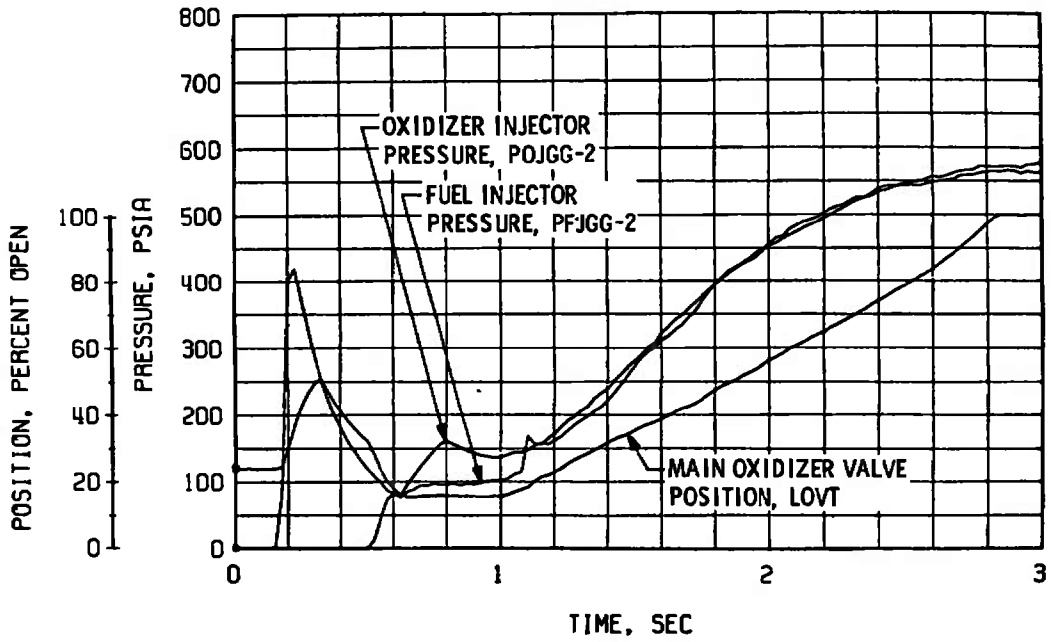

e. Gas Generator Injector Pressures and Main Oxidizer Valve Position, Start

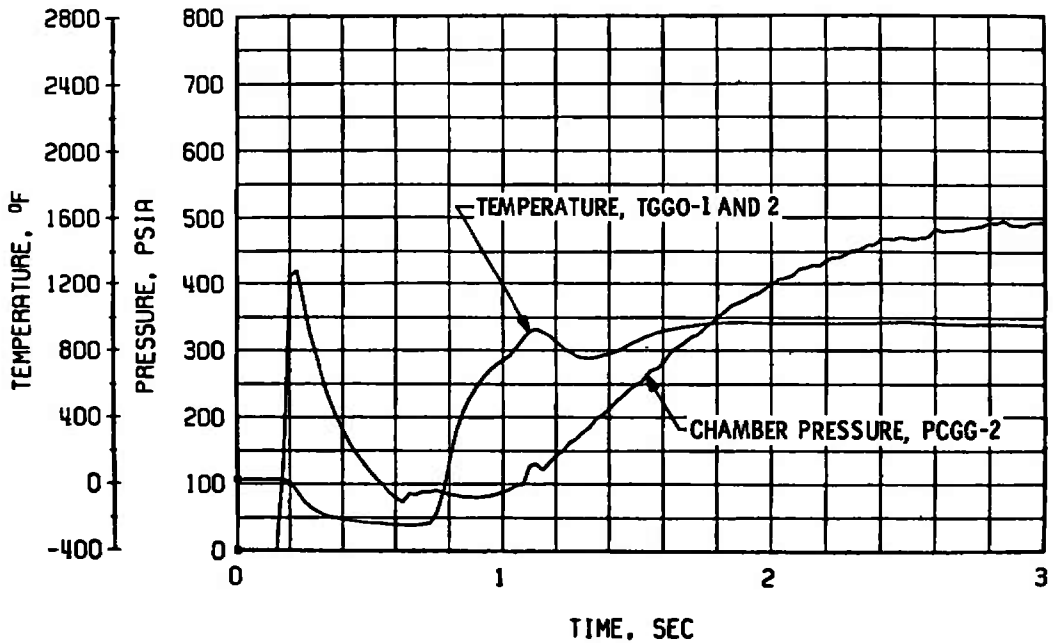

f. Gas Generator Chamber Pressure and Temperature, Start

Fig. 14 Continued

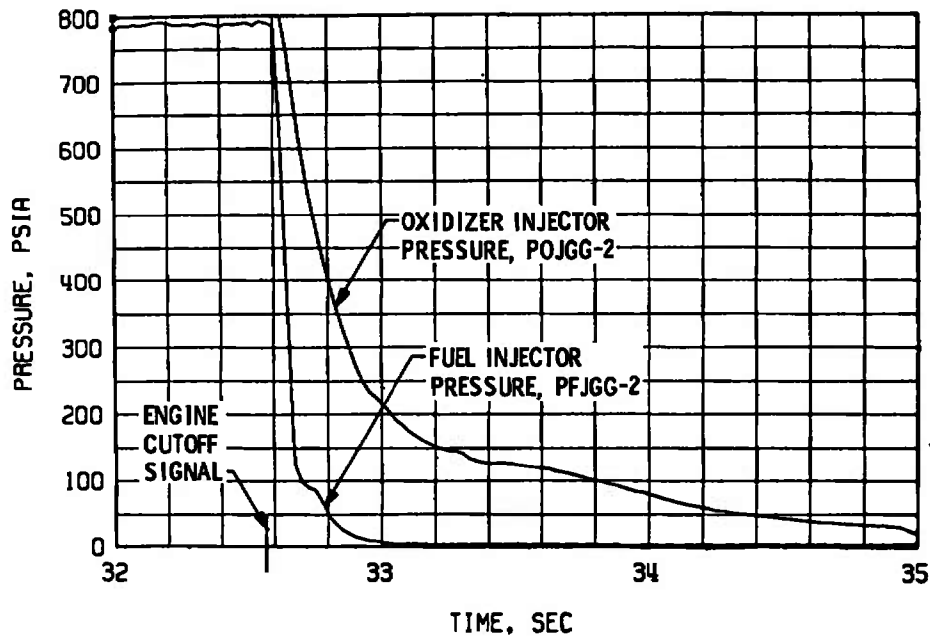

g. Gas Generator Injector Pressures, Shutdown

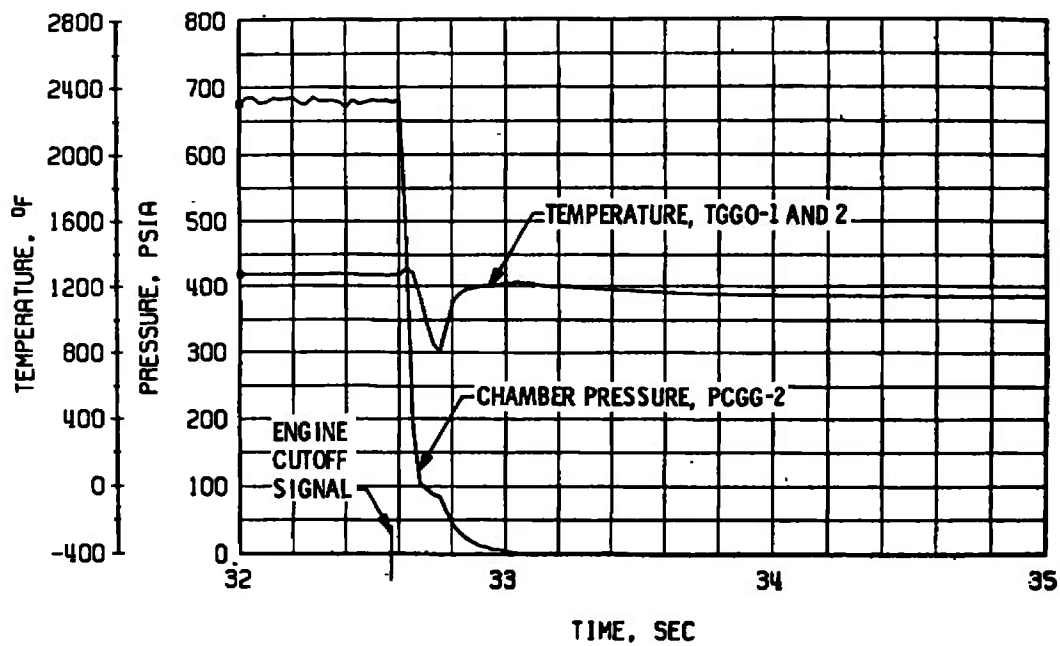

h. Gas Generator Chamber Pressure and Temperature, Shutdown

Fig. 14 Concluded

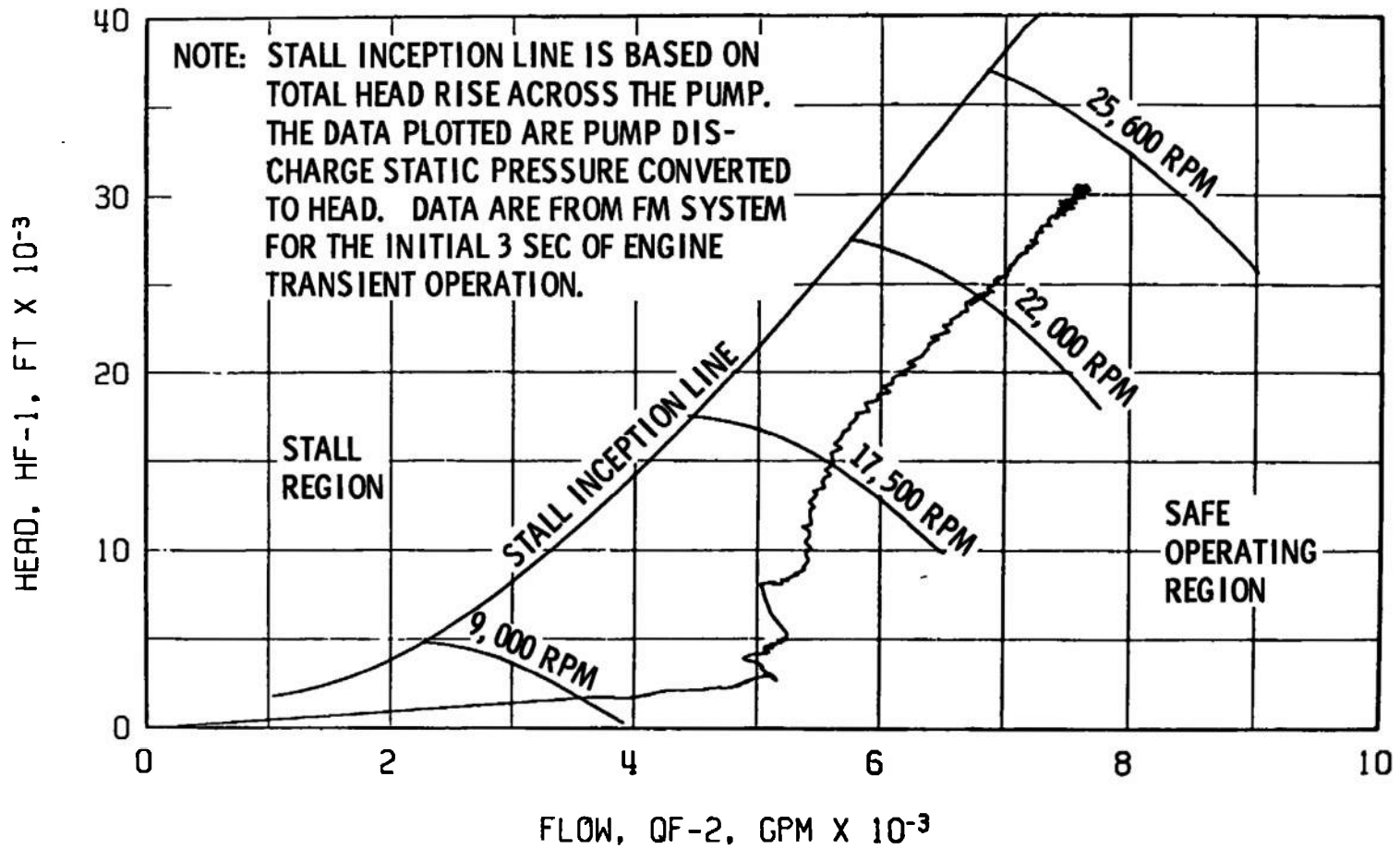

Fig. 15 Fuel Pump Start Transient Performance, Firing 09B

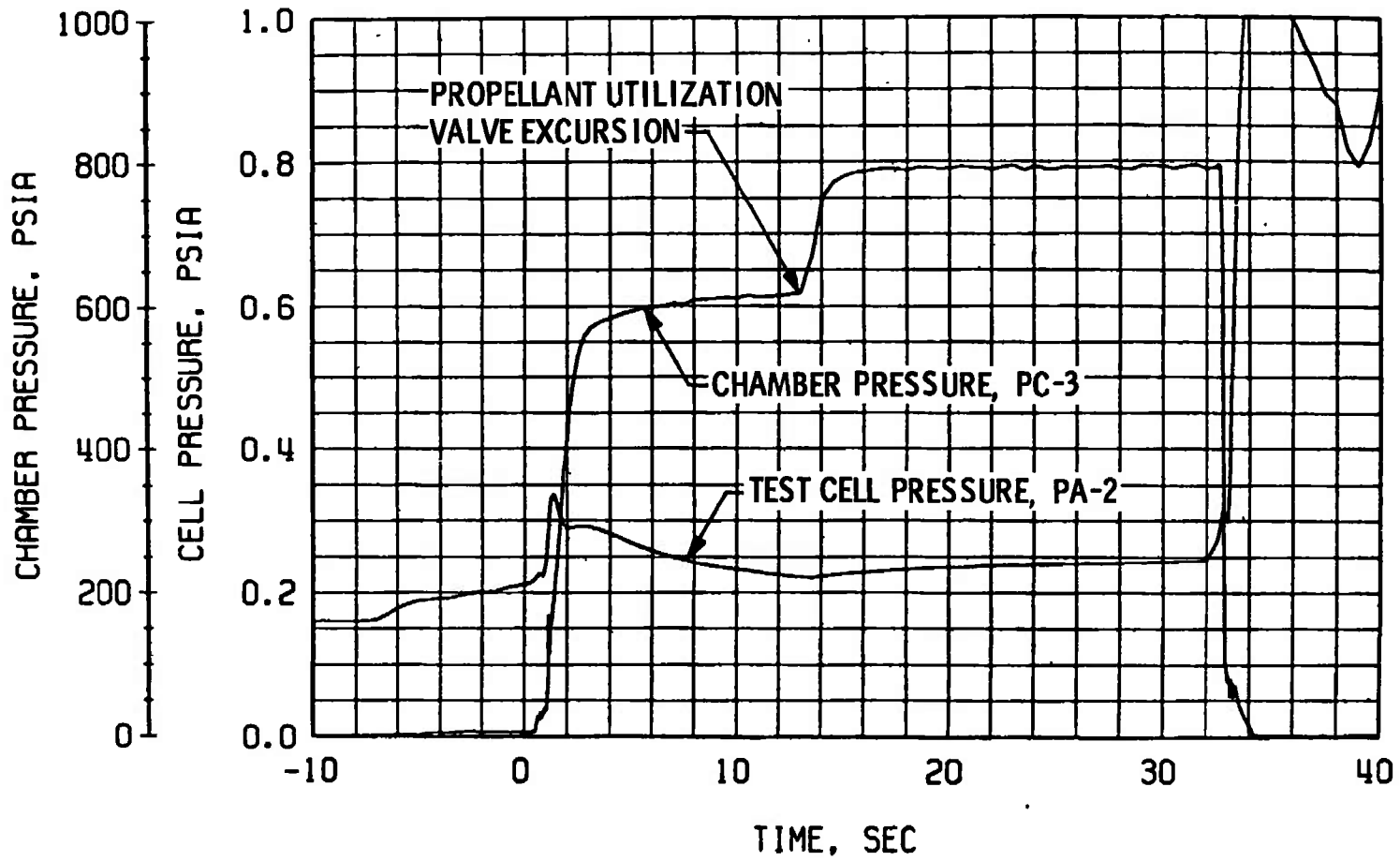
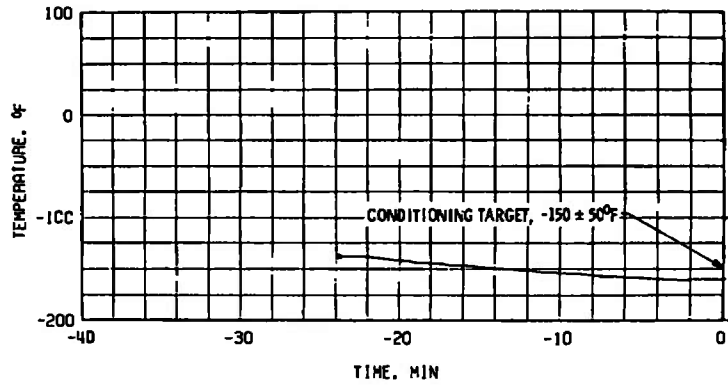
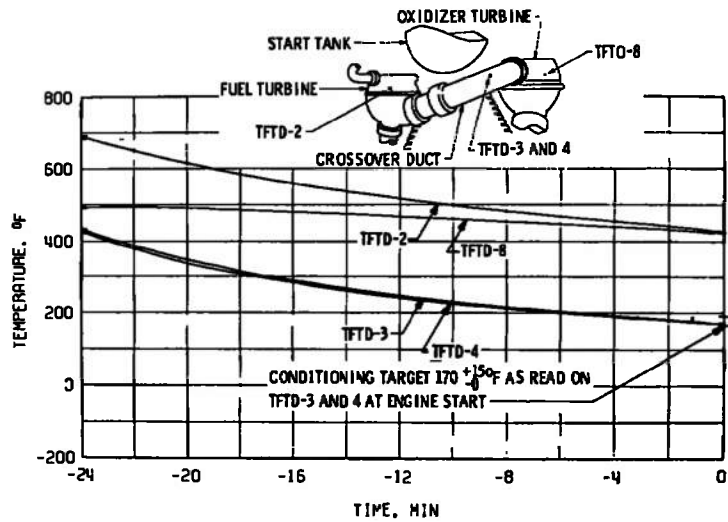

Fig. 16 Engine Ambient and Combustion Chamber Pressure, Firing 09B



a. Main Oxidizer Valve Second-Stage Actuator, TSOVC-1



b. Crossover Duct, TFTD

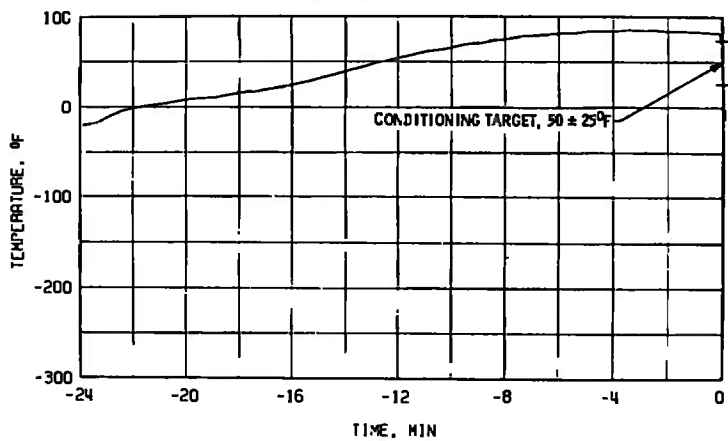

c. Thrust Chamber Throat, TTC-1P

Fig. 17 Thermal Conditioning History of Engine Components, Firing 09C

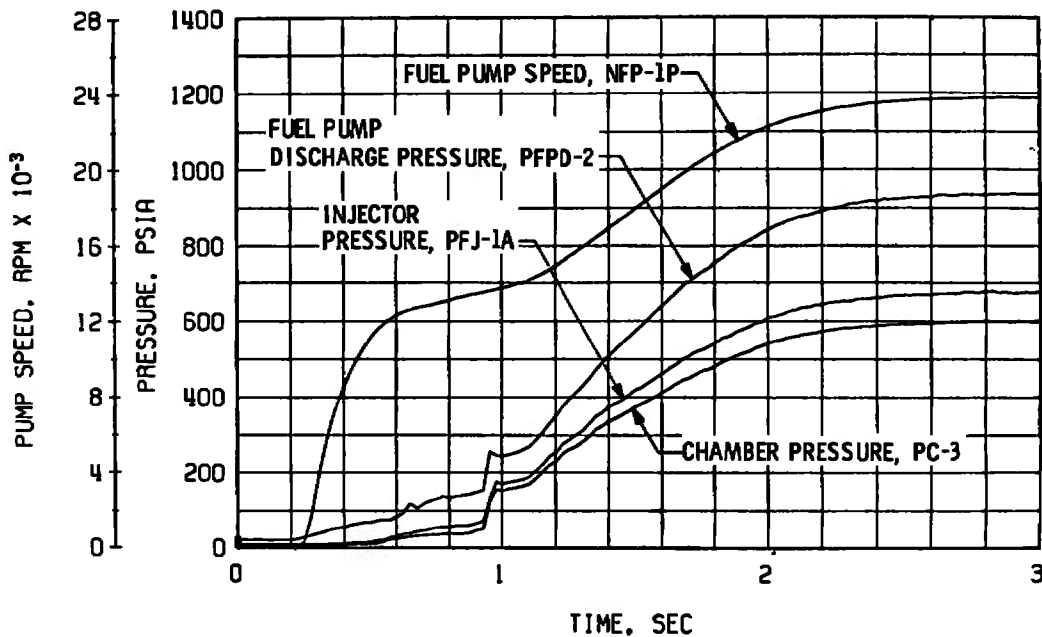

a. Thrust Chamber Fuel System, Start

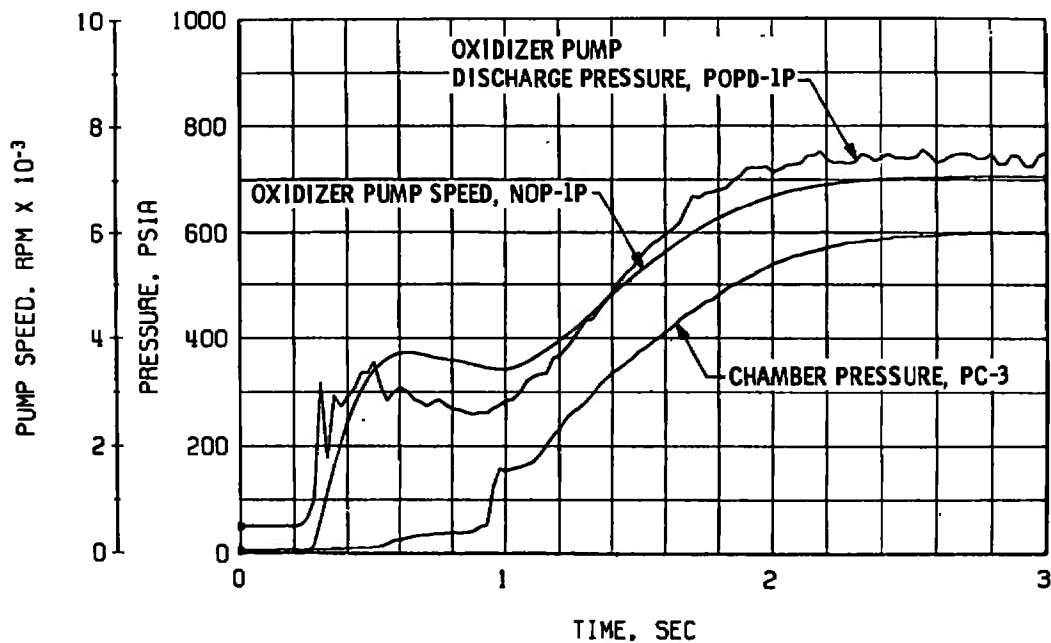

b. Thrust Chamber Oxidizer System, Start

Fig. 18 Engine Transient Operation, Firing 09C

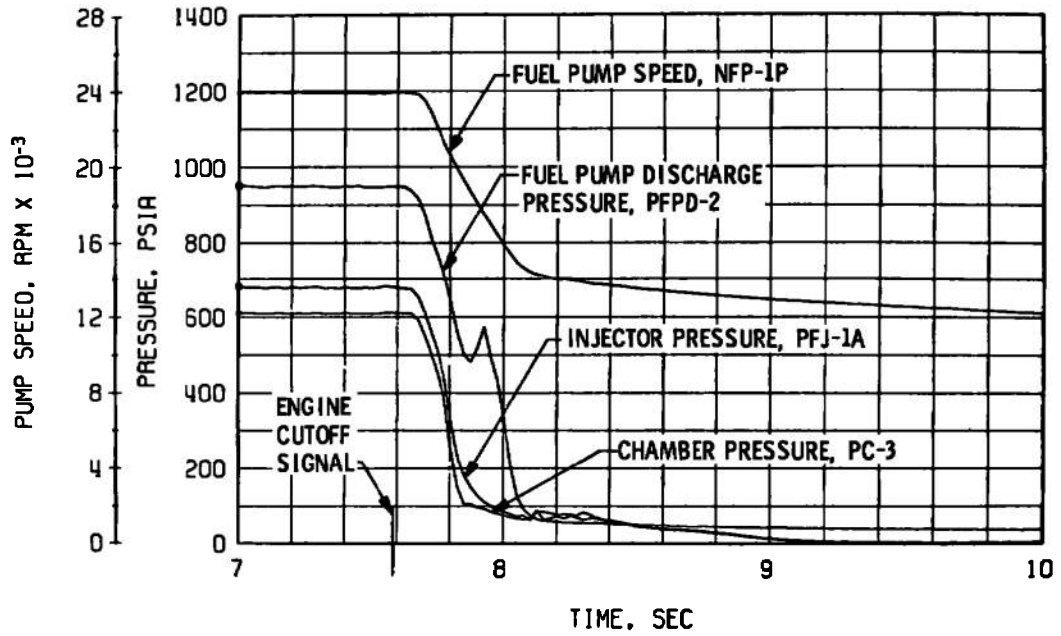

c. Thrust Chamber Fuel System, Shutdown

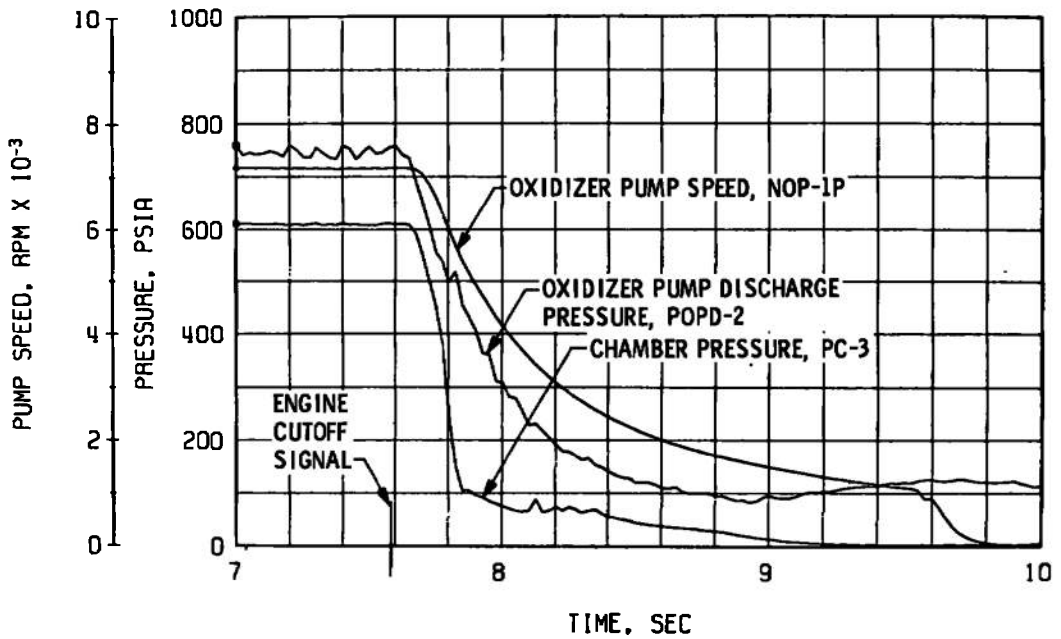

d. Thrust Chamber Oxidizer System, Shutdown

Fig. 18 Continued

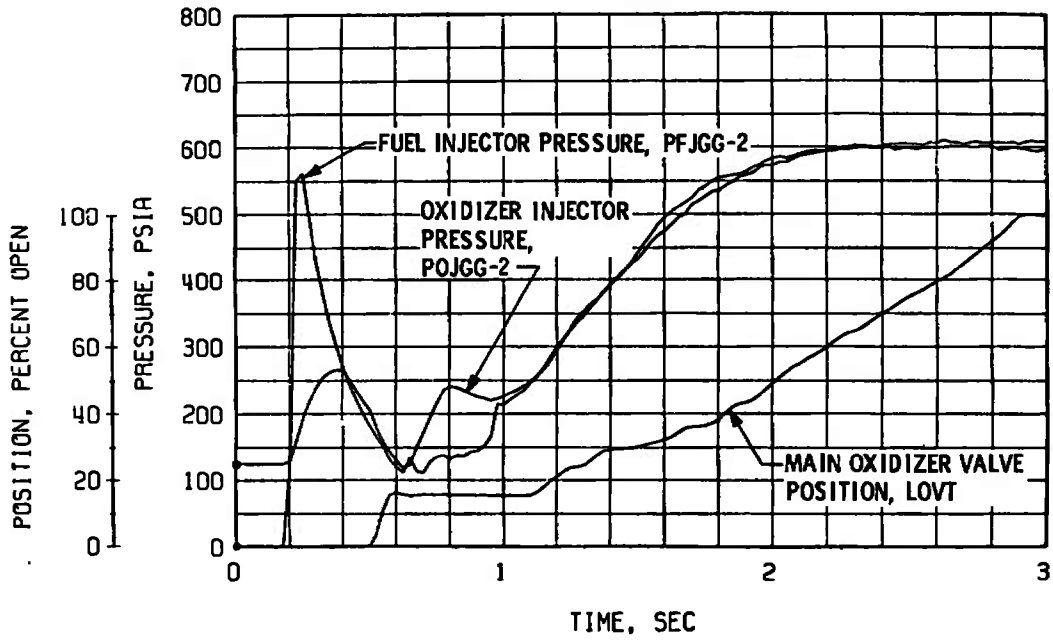

e. Gas Generator Injector Pressures and Main Oxidizer Valve Position, Start

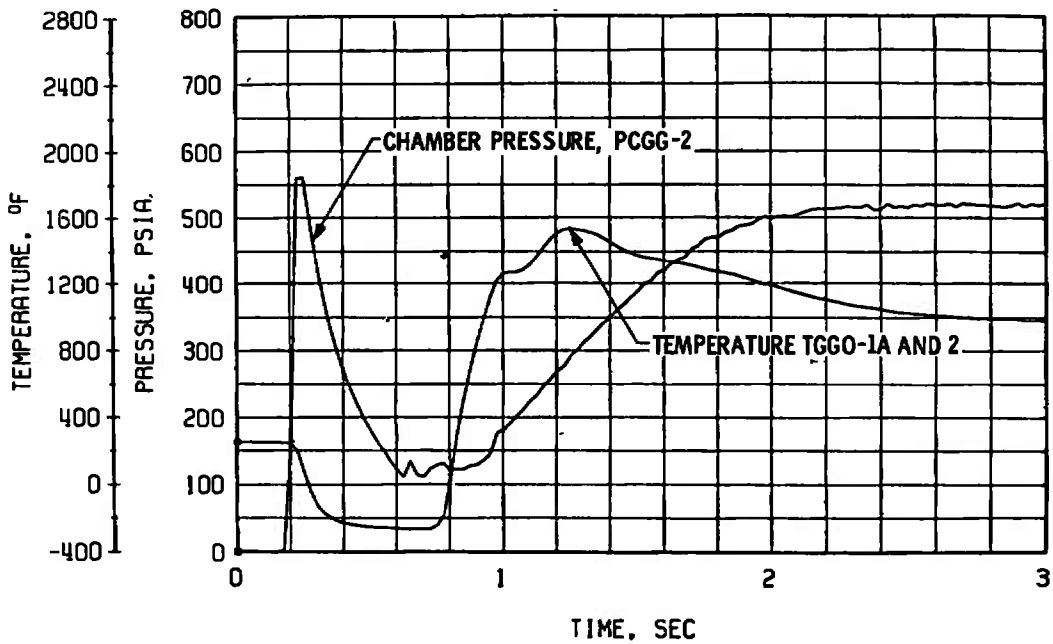

f. Gas Generator Chamber Pressure and Temperature, Start

Fig. 18 Continued

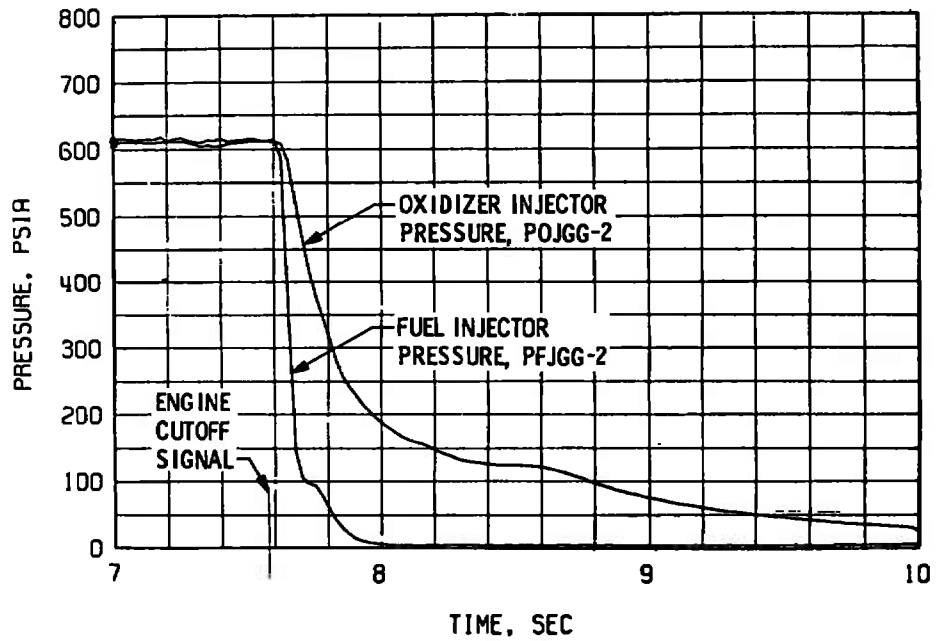

g. Gas Generator Injector Pressures, Shutdown

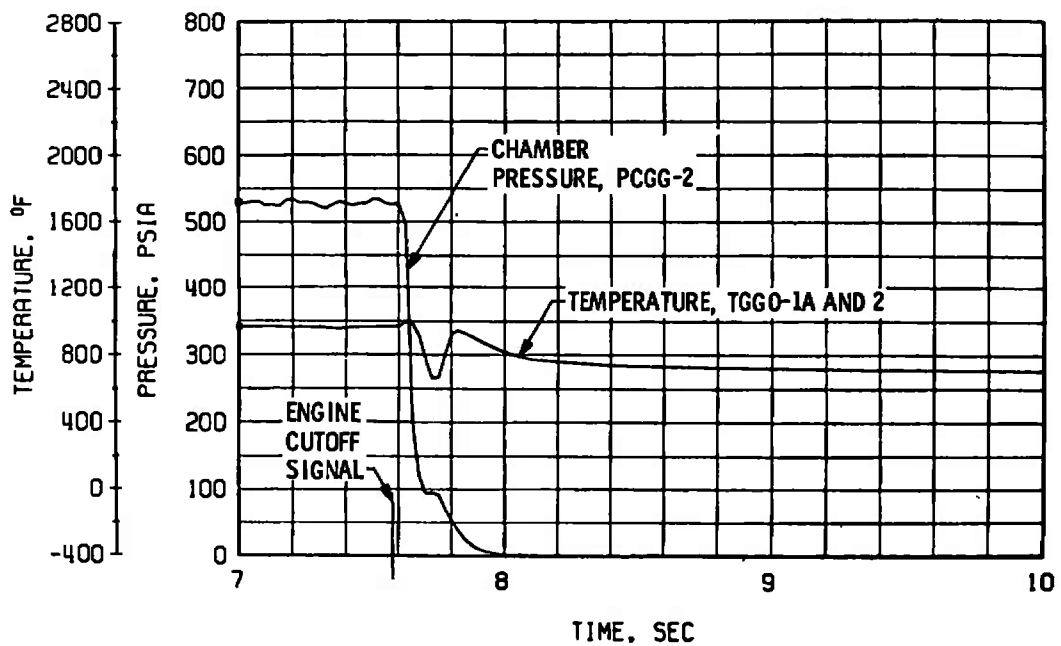

h. Gas Generator Chamber Pressure and Temperature, Shutdown

Fig. 18 Concluded

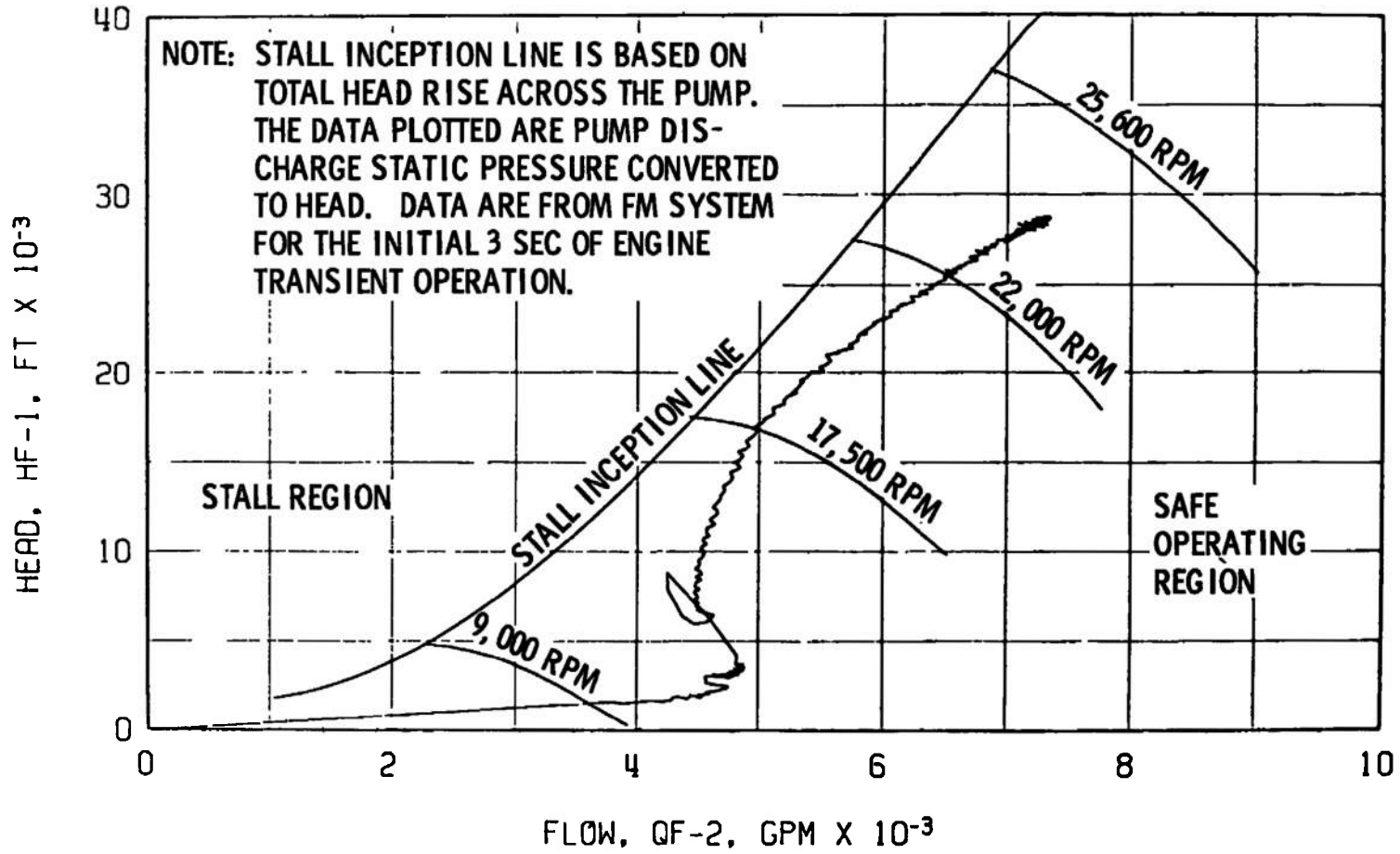

Fig. 19 Fuel Pump Start Transient Performance, Firing 09C

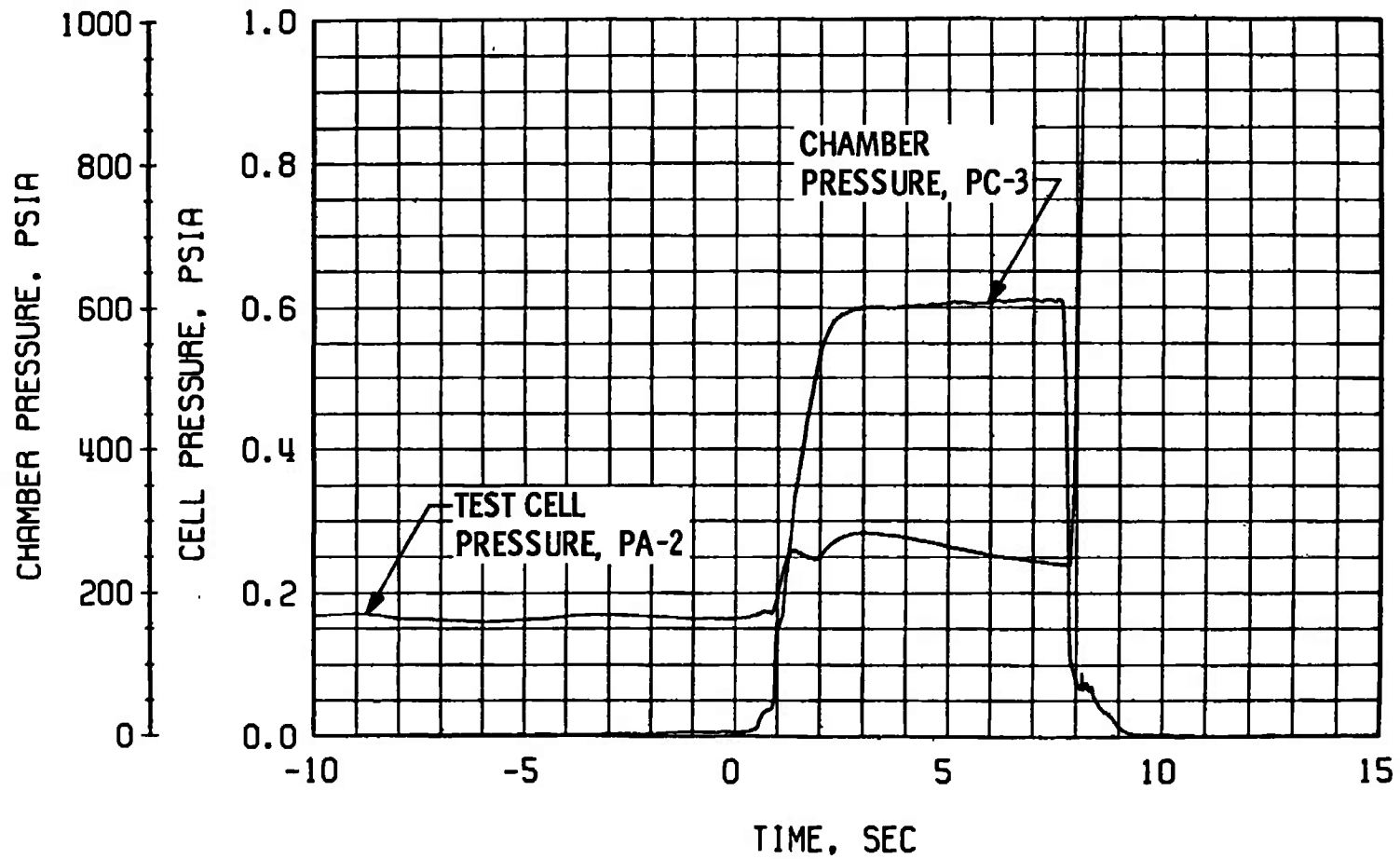
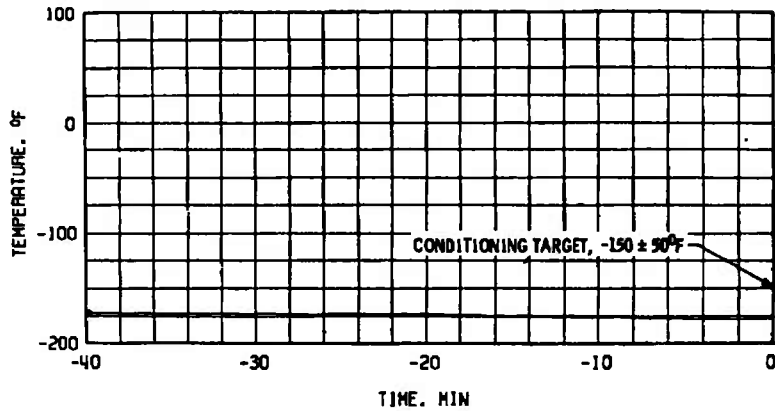
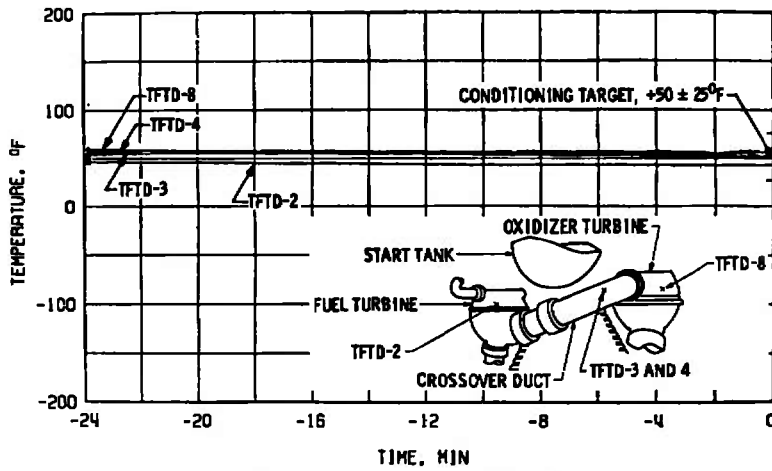

Fig. 20 Engine Ambient and Combustion Chamber Pressure, Firing 09C



a. Main Oxidizer Valve Second-Stage Actuator, TSOVC-1



b. Crossover Duct, TFTD

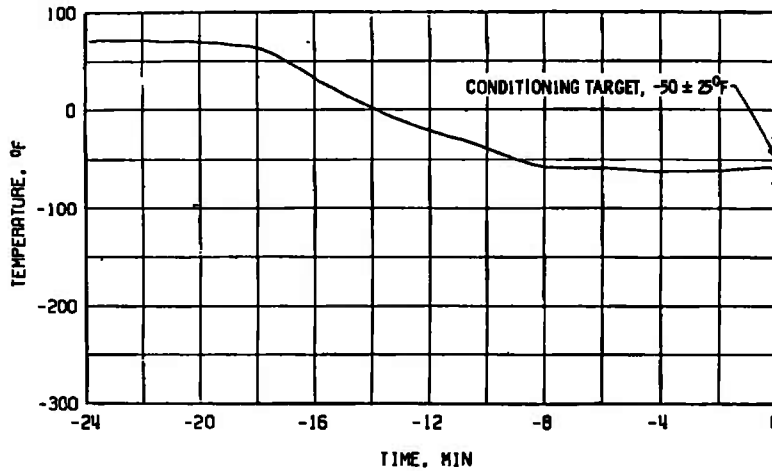

c. Thrust Chamber, TTC-1P

Fig. 21 Thermal Conditioning History of Engine Components, Firing 09D

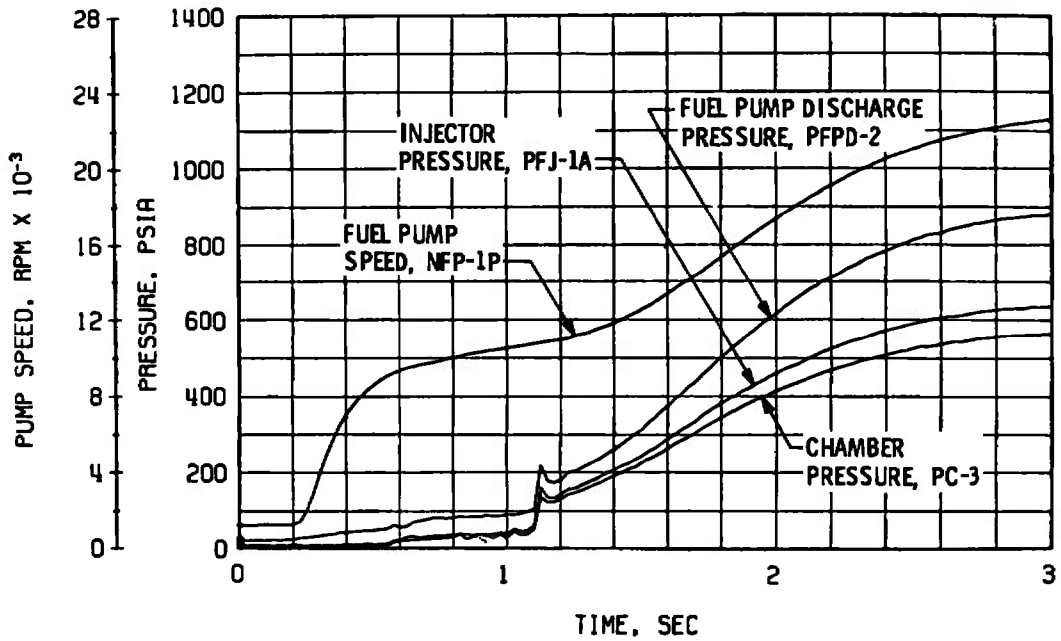

a. Thrust Chamber Fuel System, Start

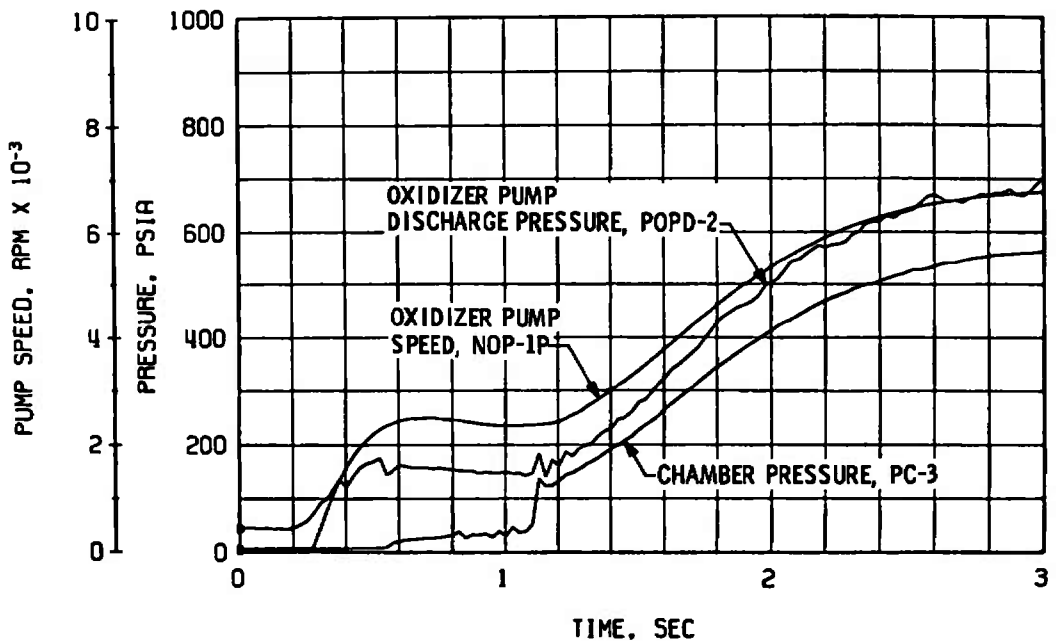

b. Thrust Chamber Oxidizer System, Start

Fig. 22 Engine Transient Operation, Firing 09D

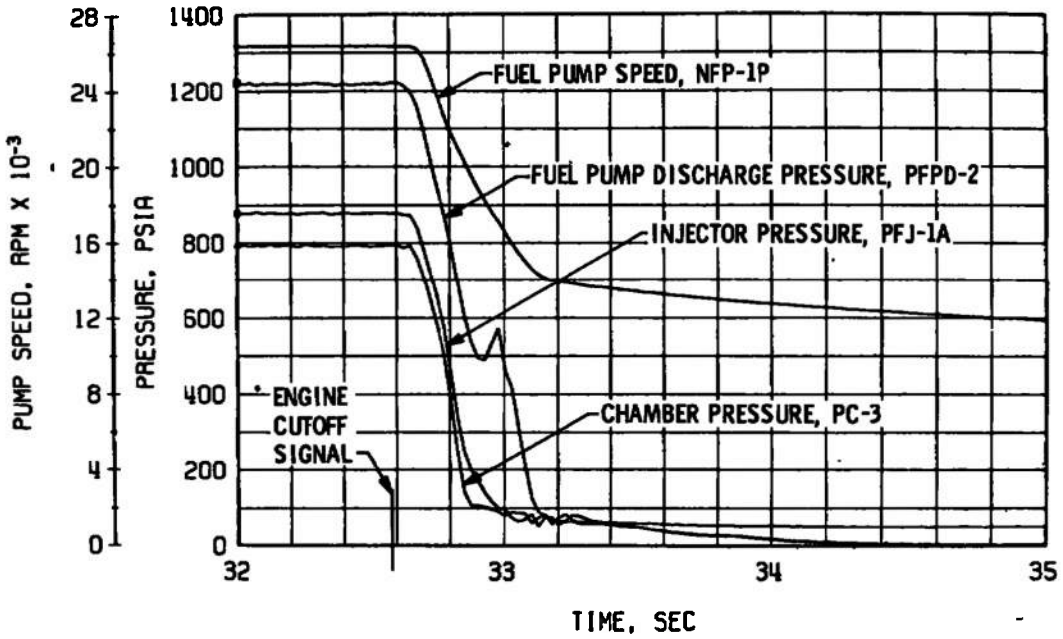

c. Thrust Chamber Fuel System, Shutdown

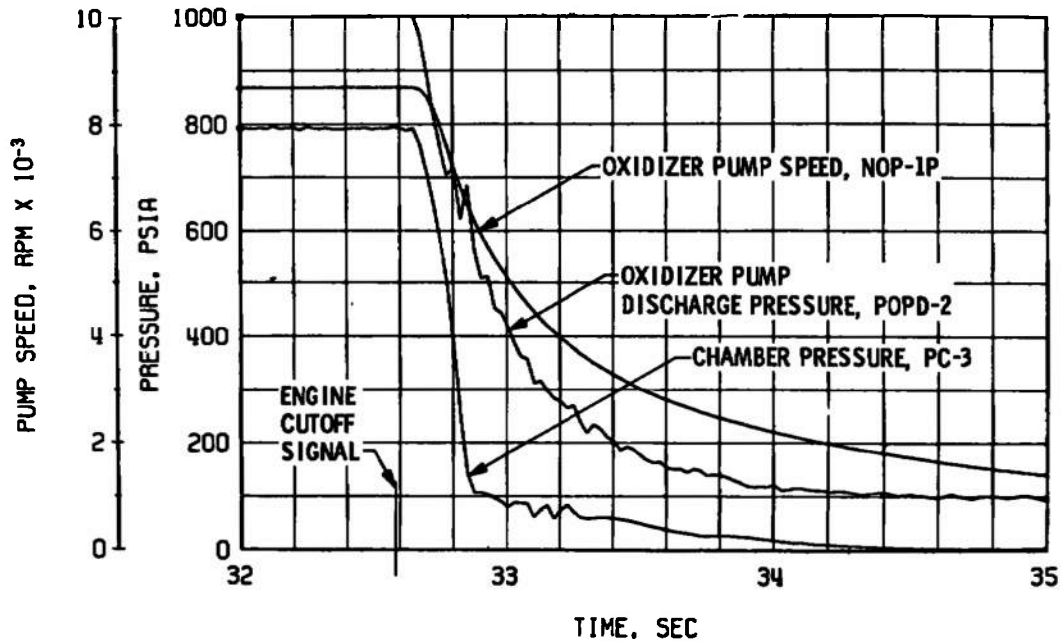

d. Thrust Chamber Oxidizer System, Shutdown

Fig. 22 Continued

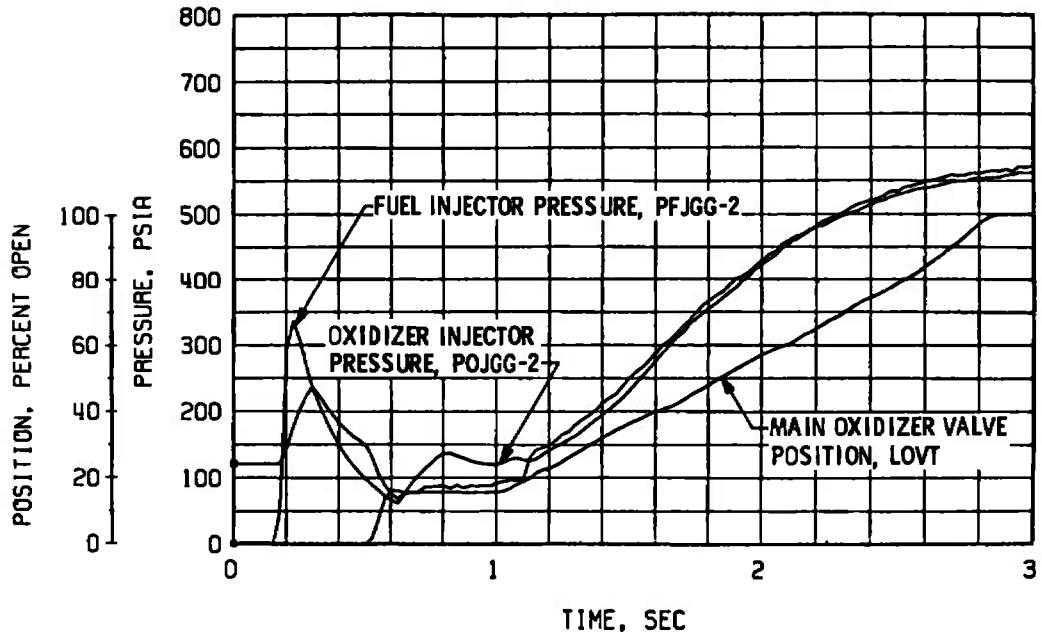

e. Gas Generator Injector Pressures and Main Oxidizer Valve Position, Start

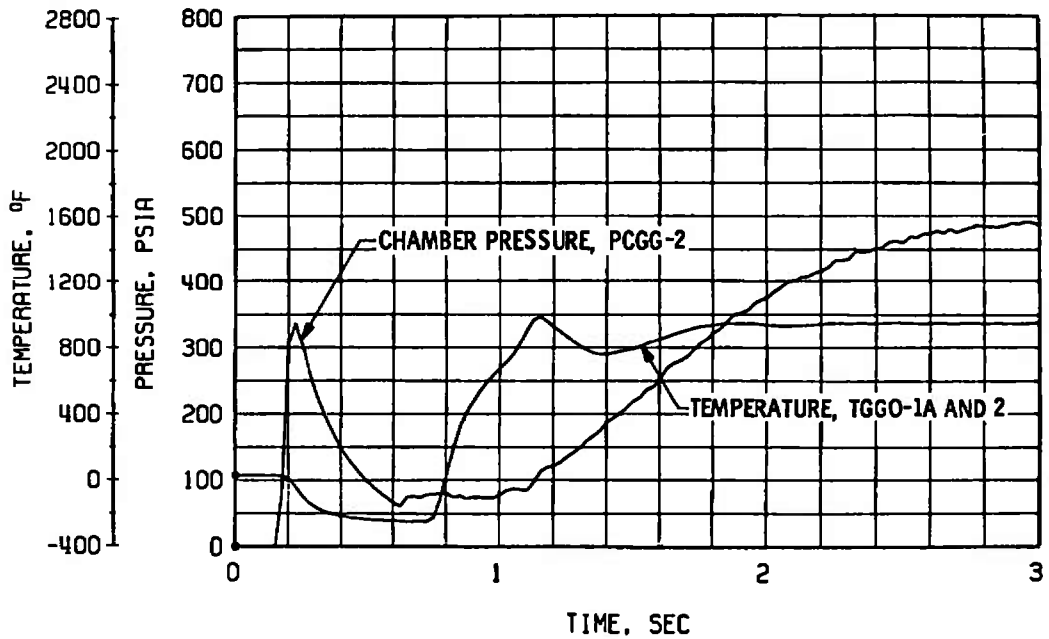

f. Gas Generator Chamber Pressure and Temperature, Start

Fig. 22 Continued

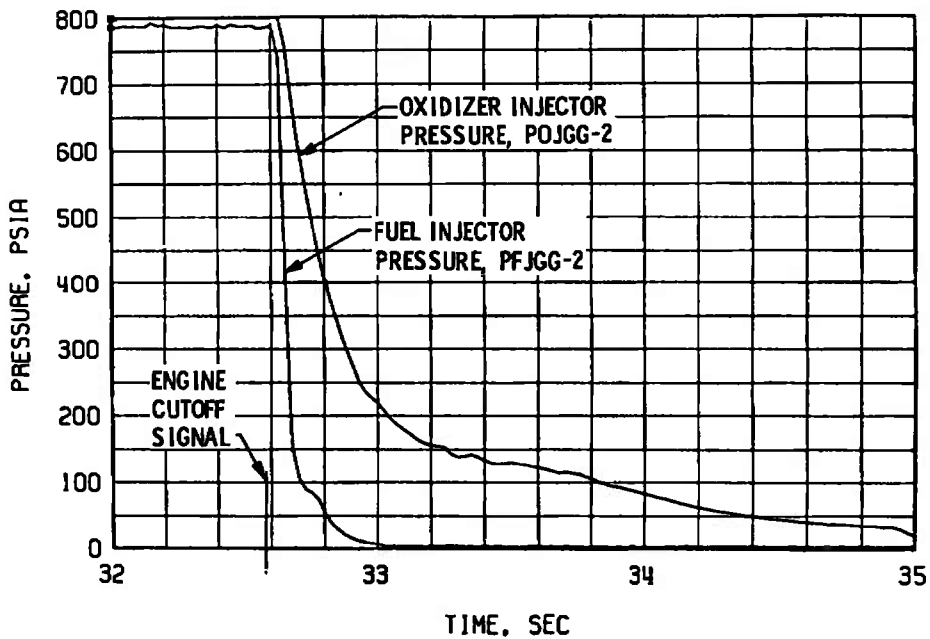

g. Gas Generator Injector Pressures, Shutdown

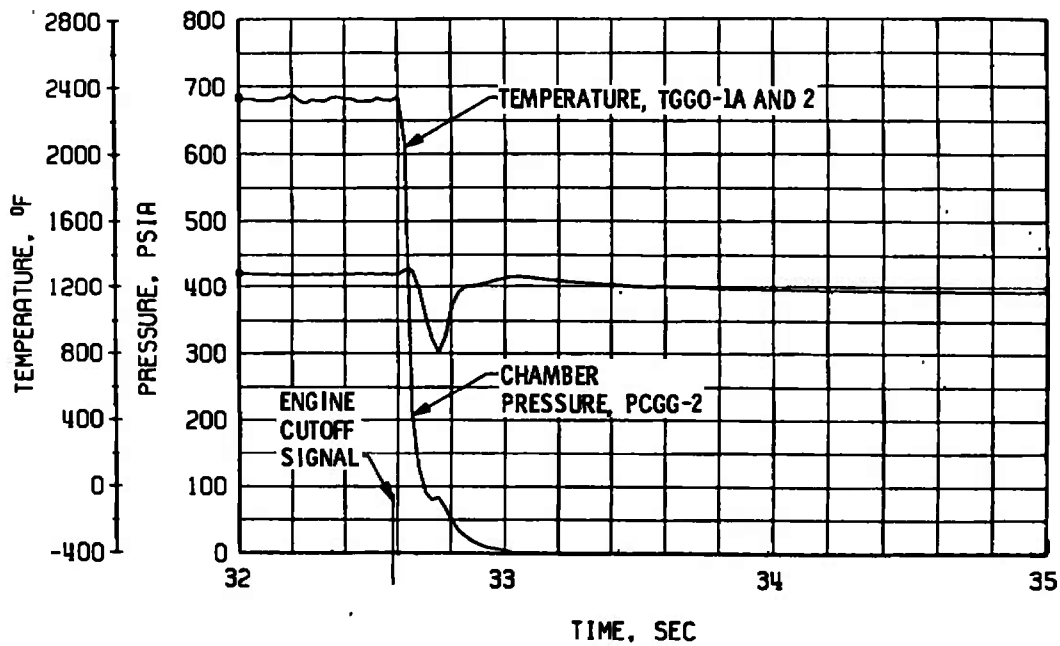

h. Gas Generator Chamber Pressure and Temperature, Shutdown

Fig. 22 Concluded

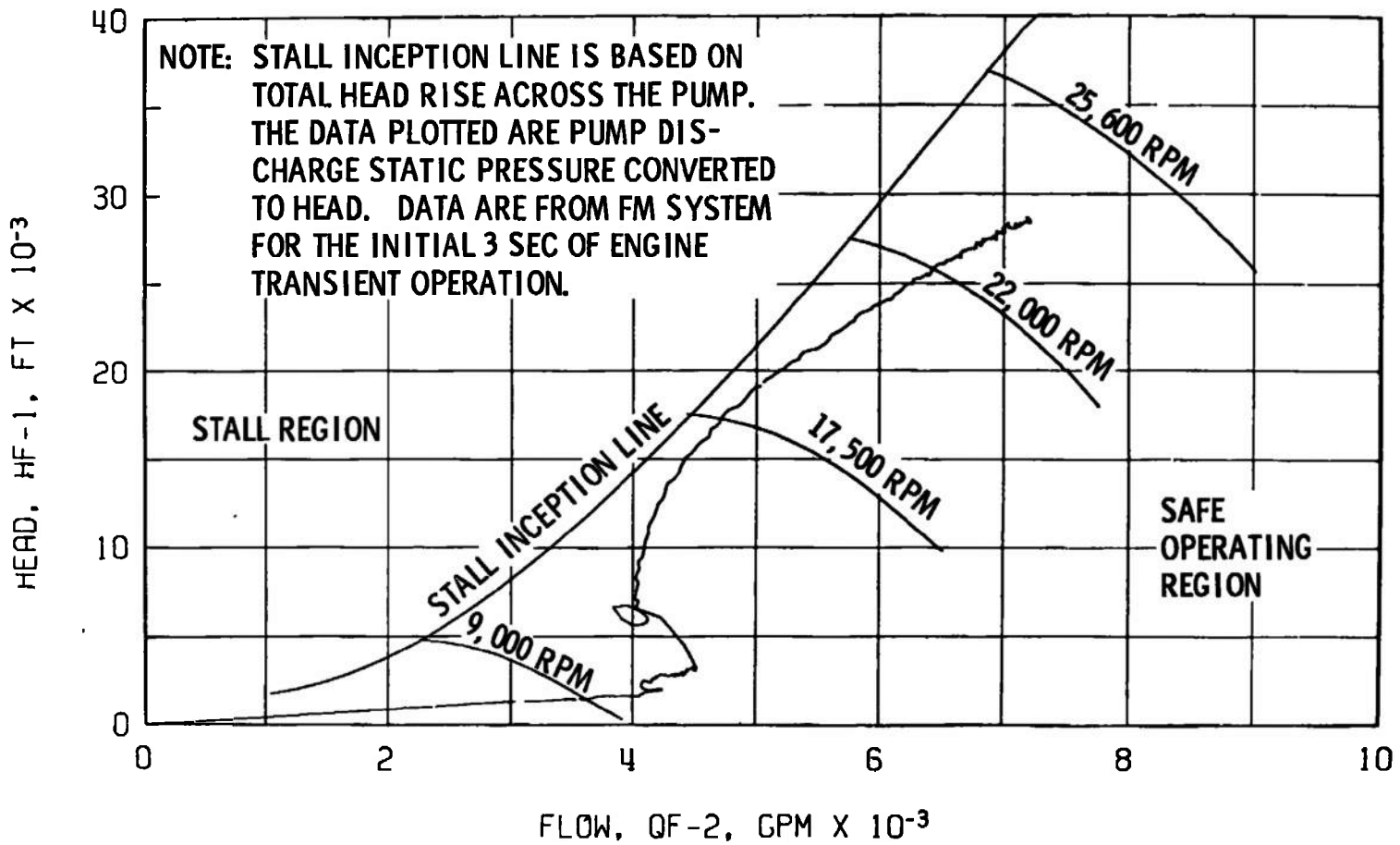

Fig. 23 Fuel Pump Start Transient Performance, Firing 09D

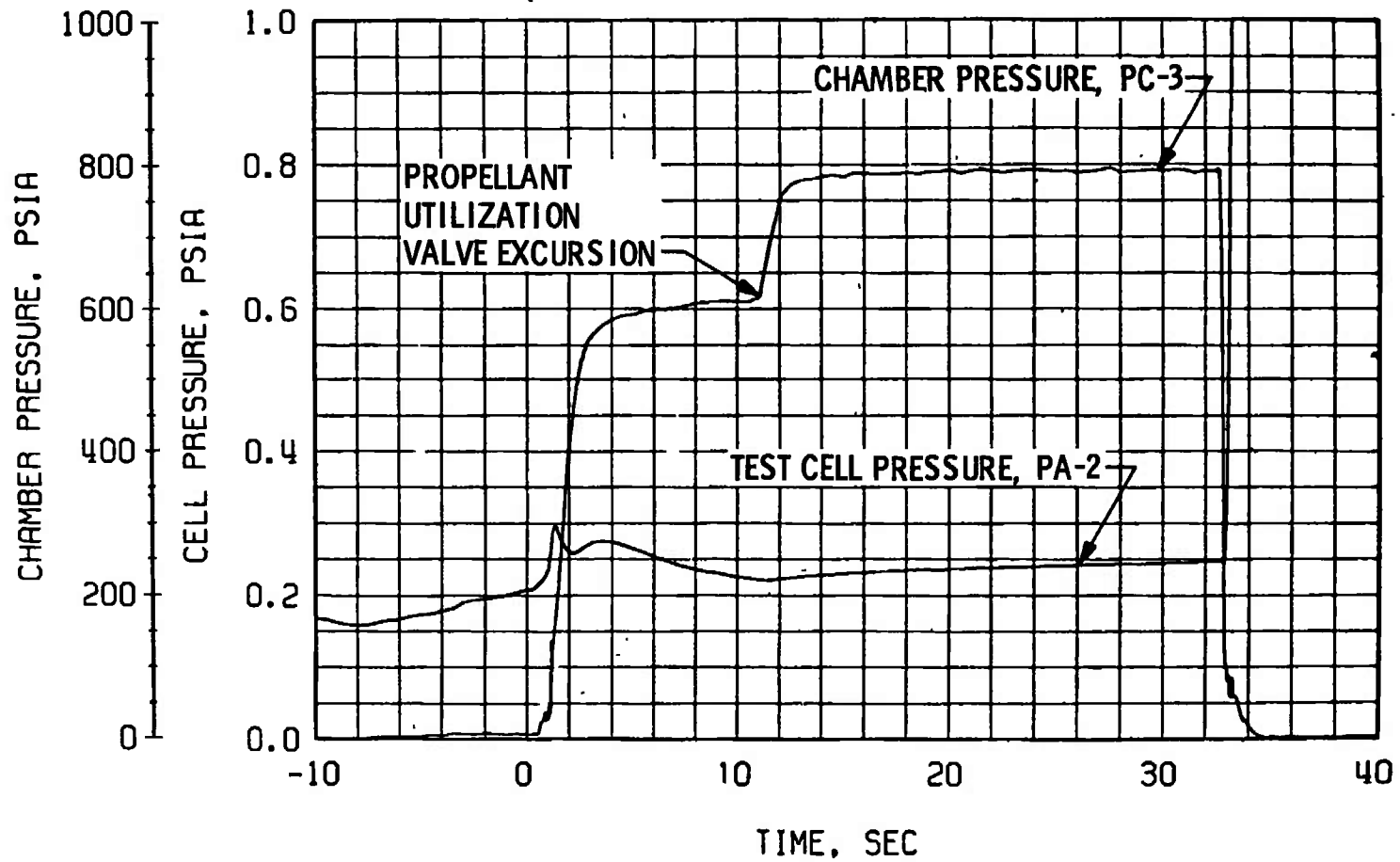
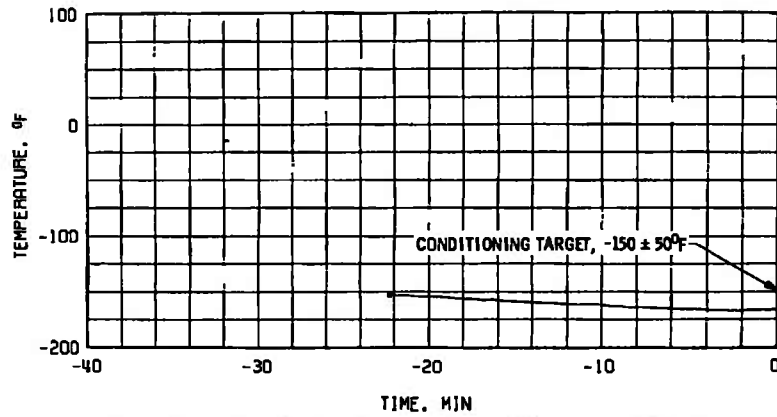
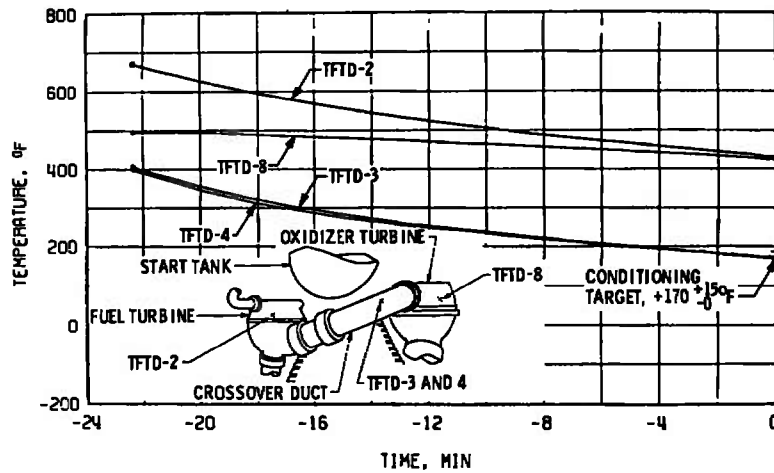

Fig. 24 Engine Ambient and Combustion Chamber Pressure, Firing 09D



a. Main Oxidizer Valve Second-Stage Actuator, TSOVC-1



b. Crossover Duct, TFTD

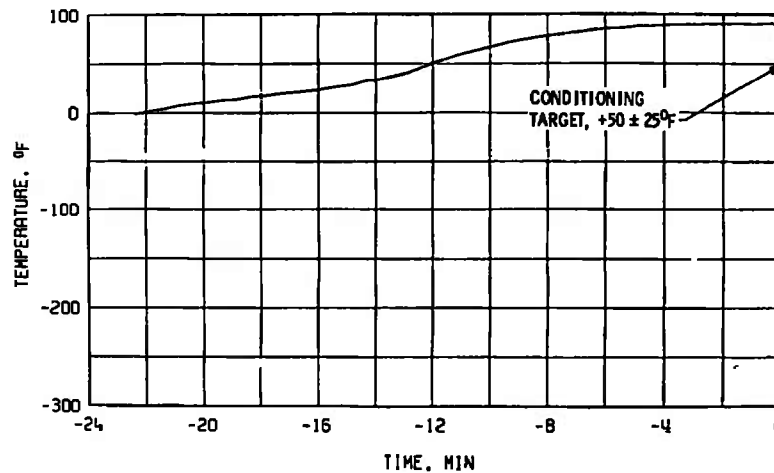

c. Thrust Chamber, TTC-1P

Fig. 25 Thermal Conditioning History of Engine Components, Firing 09E

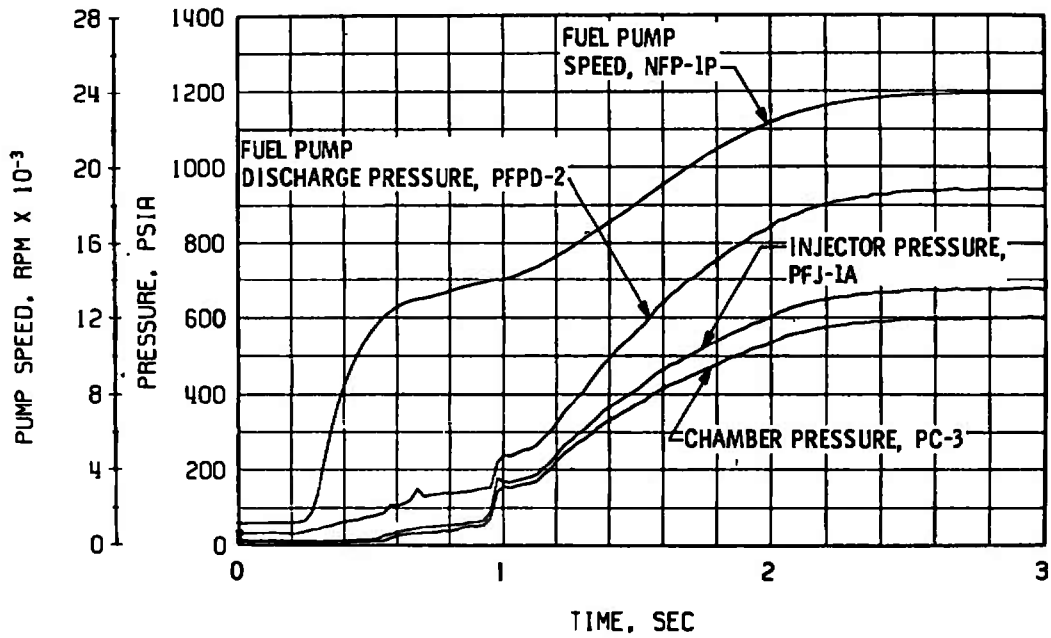

a. Thrust Chamber Fuel System

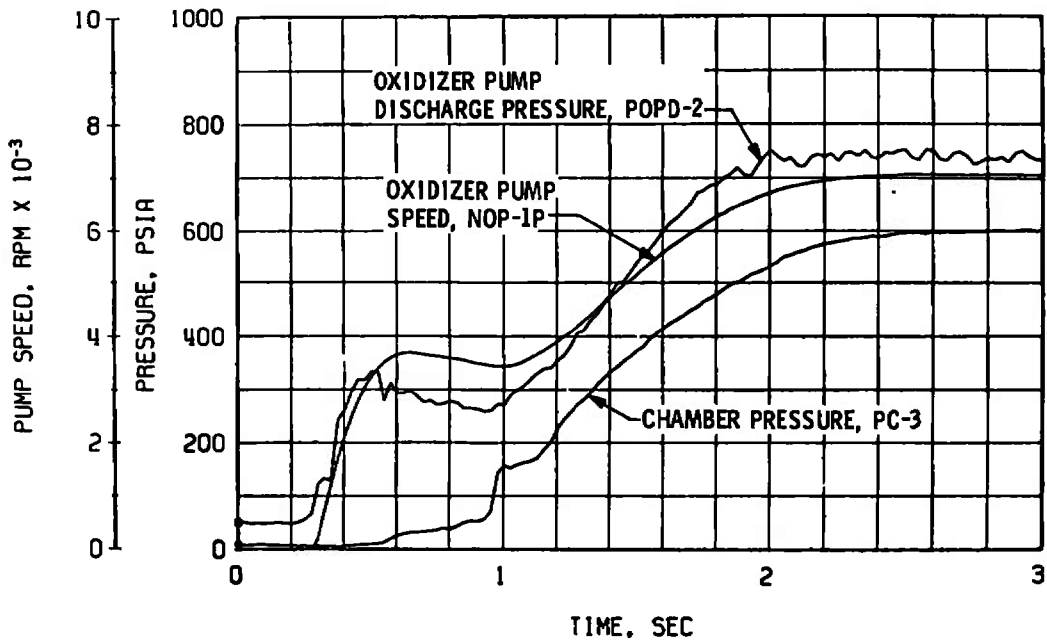

b. Thrust Chamber Oxidizer System, Start

Fig. 26 Engine Transient Operation, Firing 09E

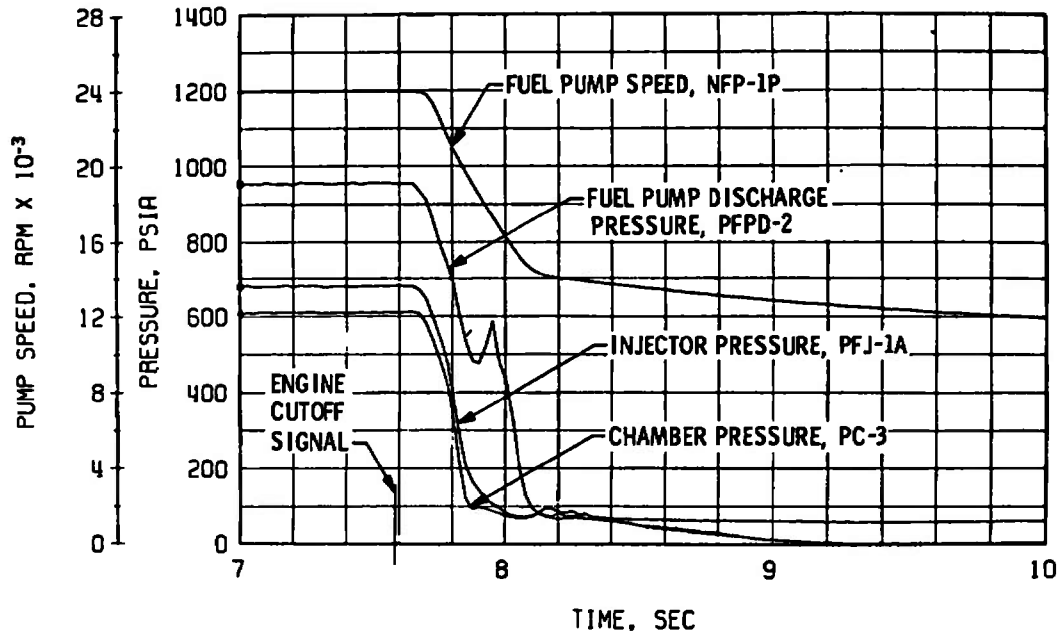

c. Thrust Chamber Fuel System, Shutdown

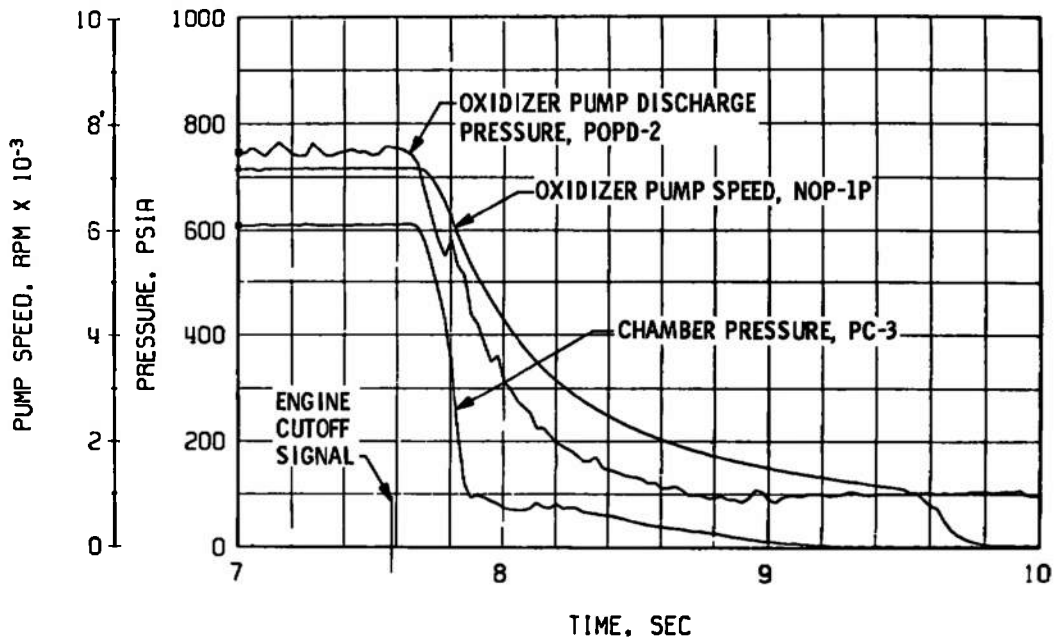

d. Thrust Chamber Oxidizer System, Shutdown

Fig. 26 Continued

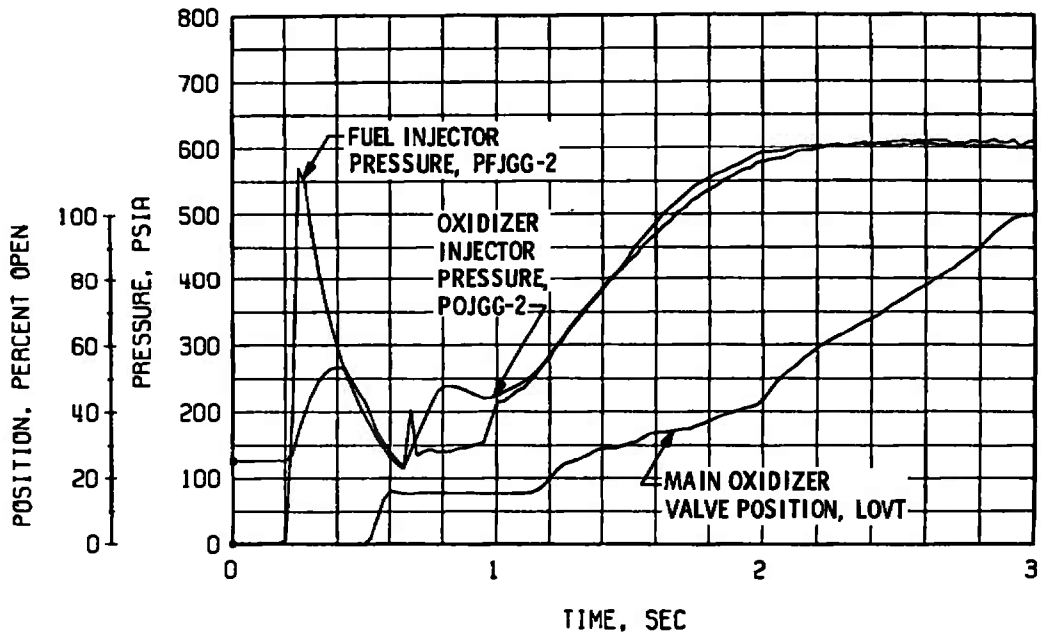

e. Gas Generator Injector Pressures and Main Oxidizer Valve Position, Start

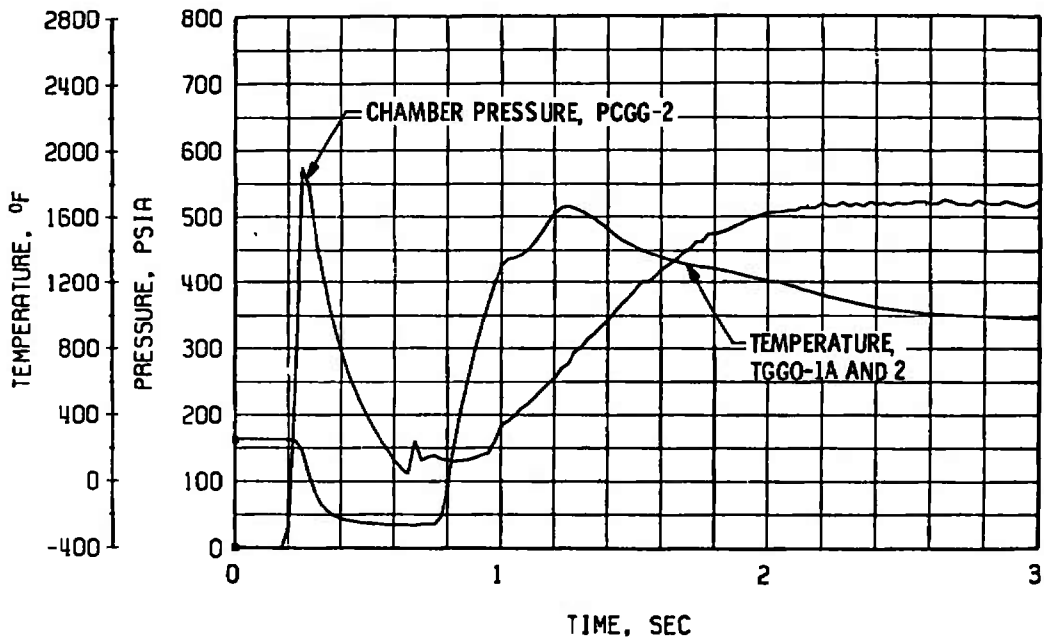

f. Gas Generator Chamber Pressure and Temperature, Start

Fig. 26 Continued

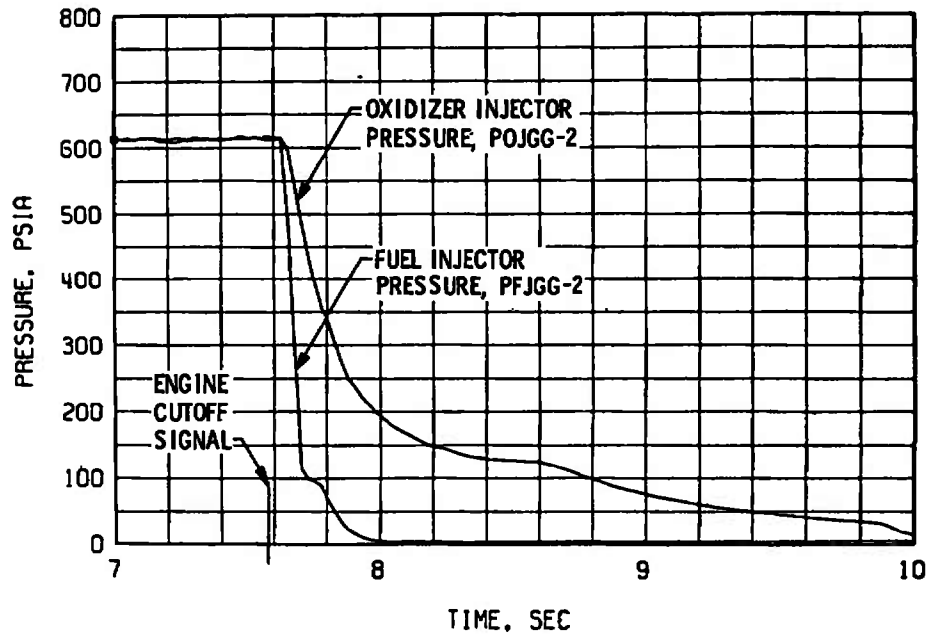

g. Gas Generator Injector Pressures, Shutdown

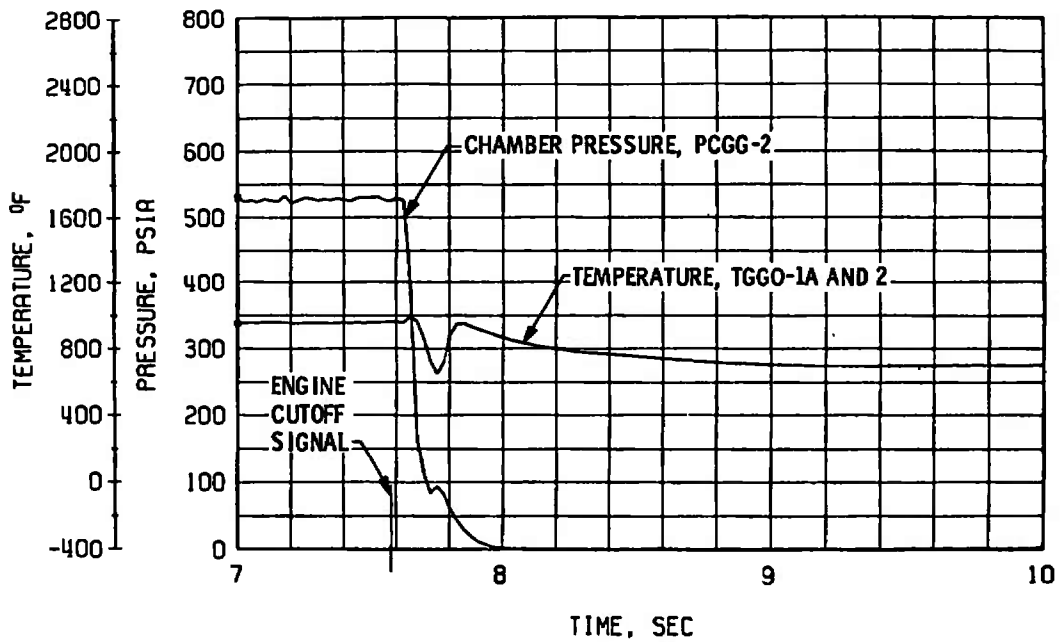

h. Gas Generator Chamber Pressure and Temperature. Shutdown

Fig. 26 Concluded

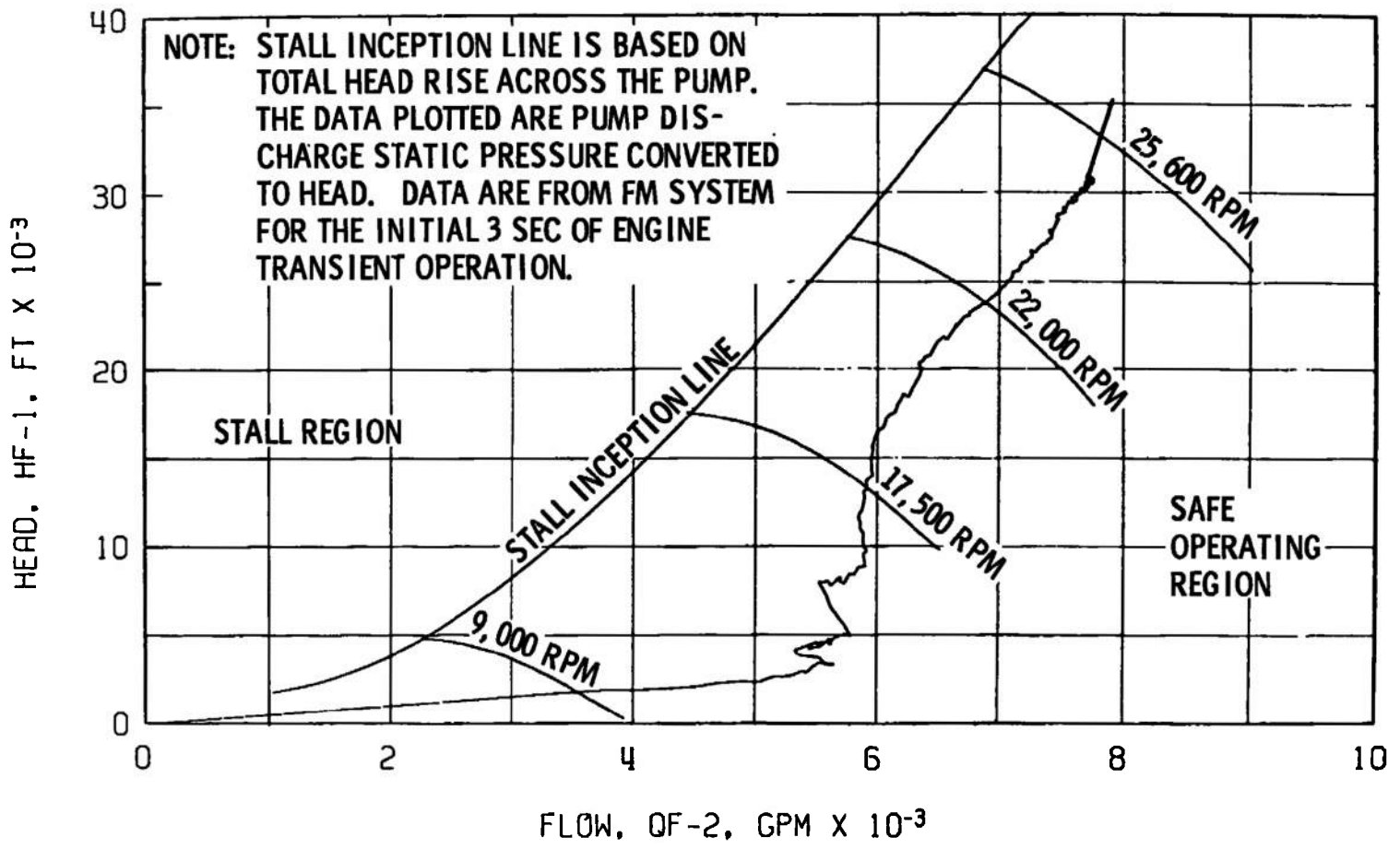

Fig. 27 Fuel Pump Start Transient Performance, Firing 09E

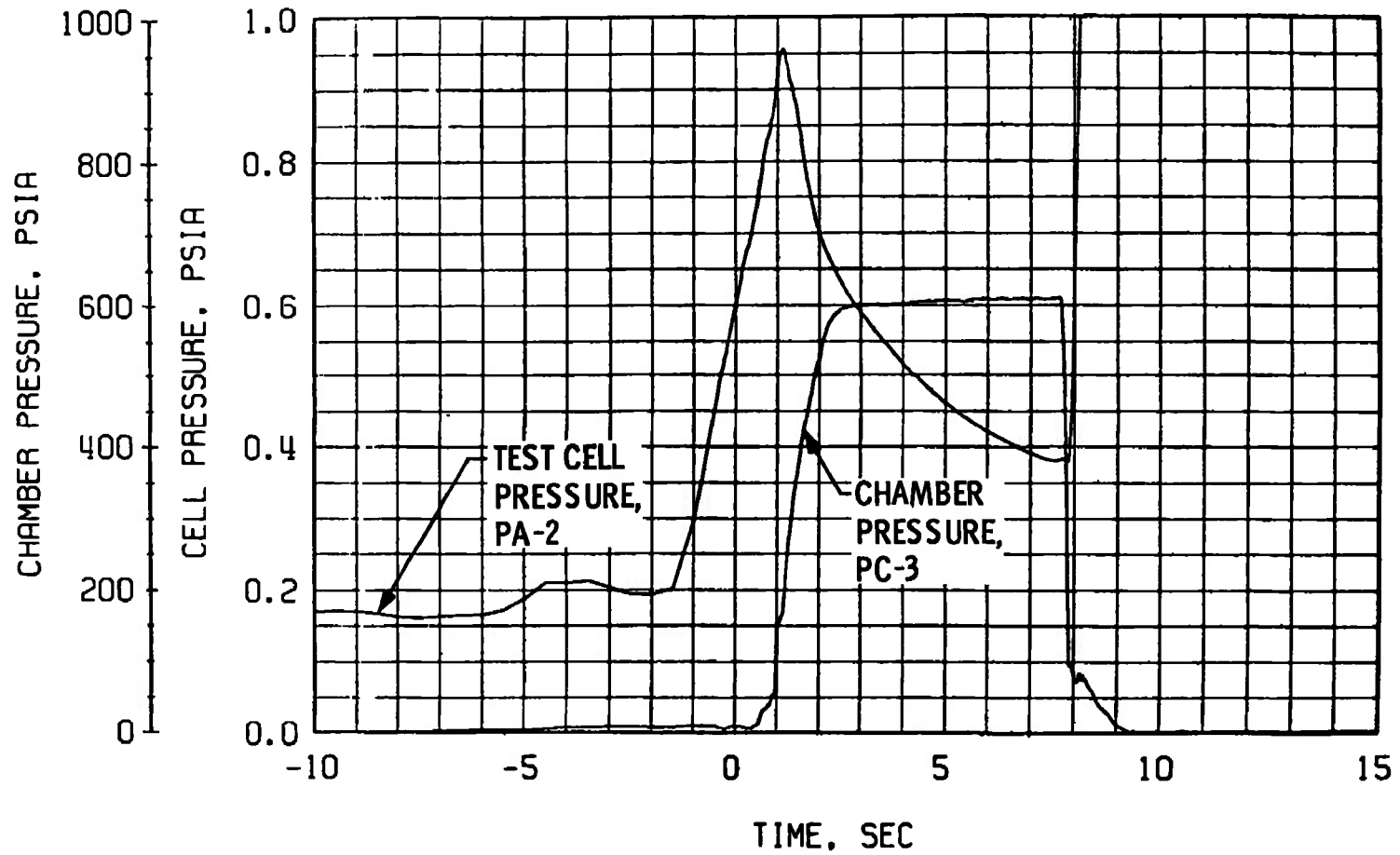
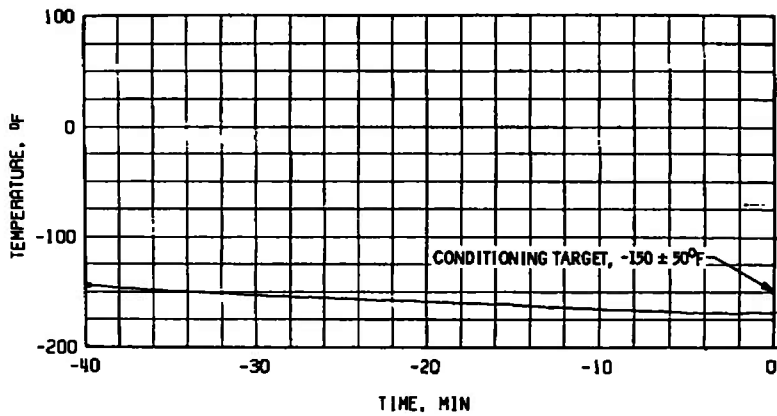
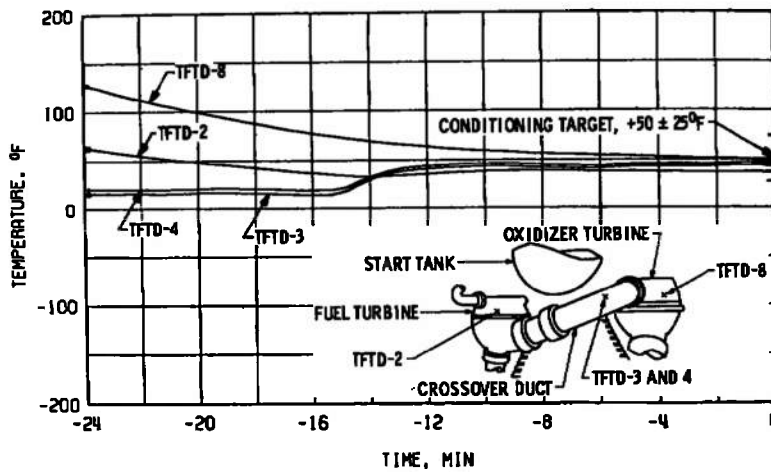

Fig. 28 Engine Ambient and Combustion Chamber Pressure, Firing 09E



a. Main Oxidizer Valve Second-Stage Actuator, TSOVC-1



b. Crossover Duct, TFTD

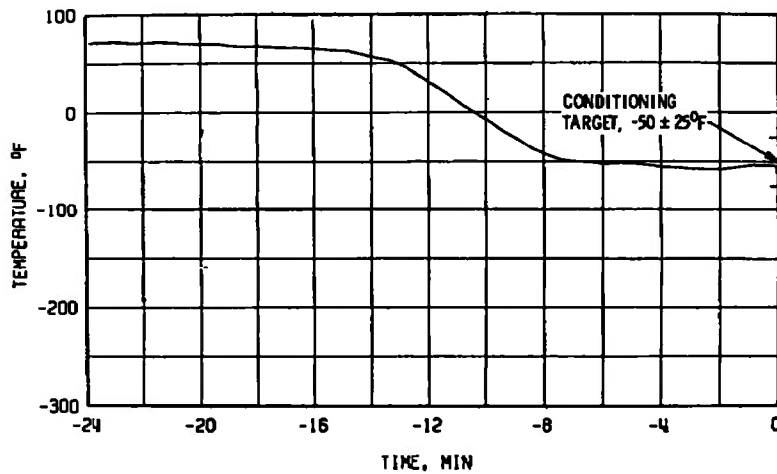

c. Thrust Chamber, TTC-1P

Fig. 29 Thermal Conditioning History of Engine Components, Firing 09F

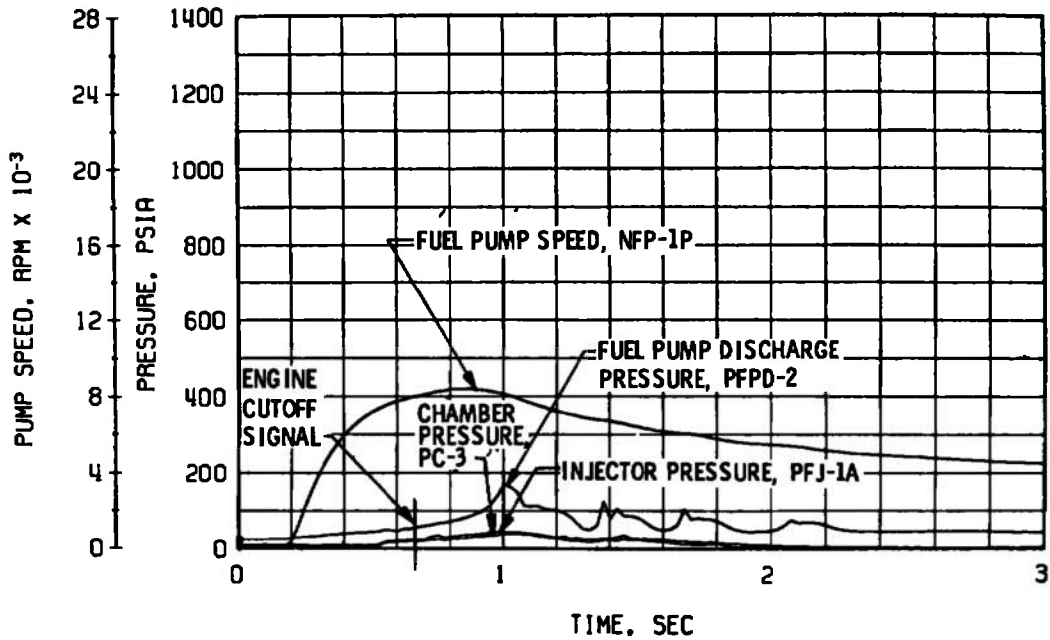

a. Thrust Chamber Fuel System, Start and Shutdown

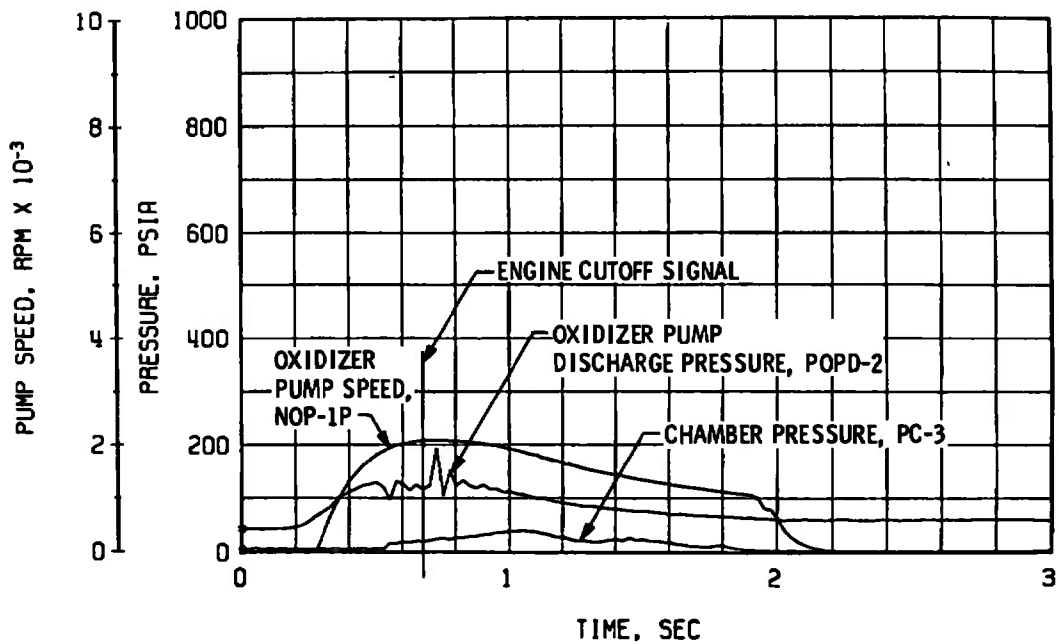

b. Thrust Chamber Oxidizer System, Start and Shutdown

Fig. 30 Engine Transient Operation, Firing 09F

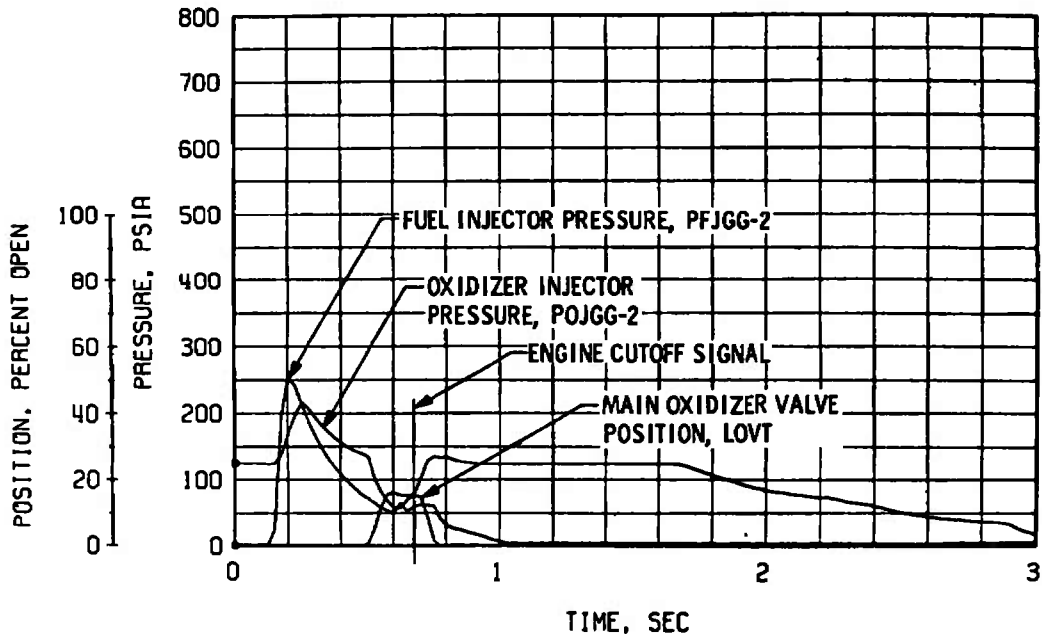

c. Gas Generator Injector Pressures and Main Oxidizer Valve Position, Start and Shutdown

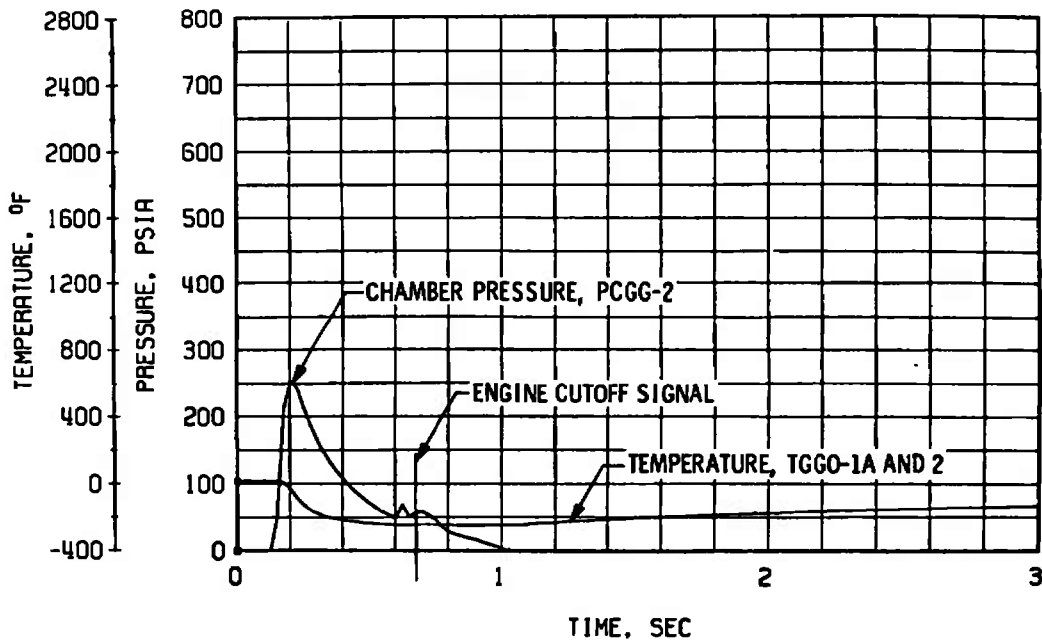

d. Gas Generator Chamber Pressure and Temperature, Start and Shutdown

Fig. 30 Concluded

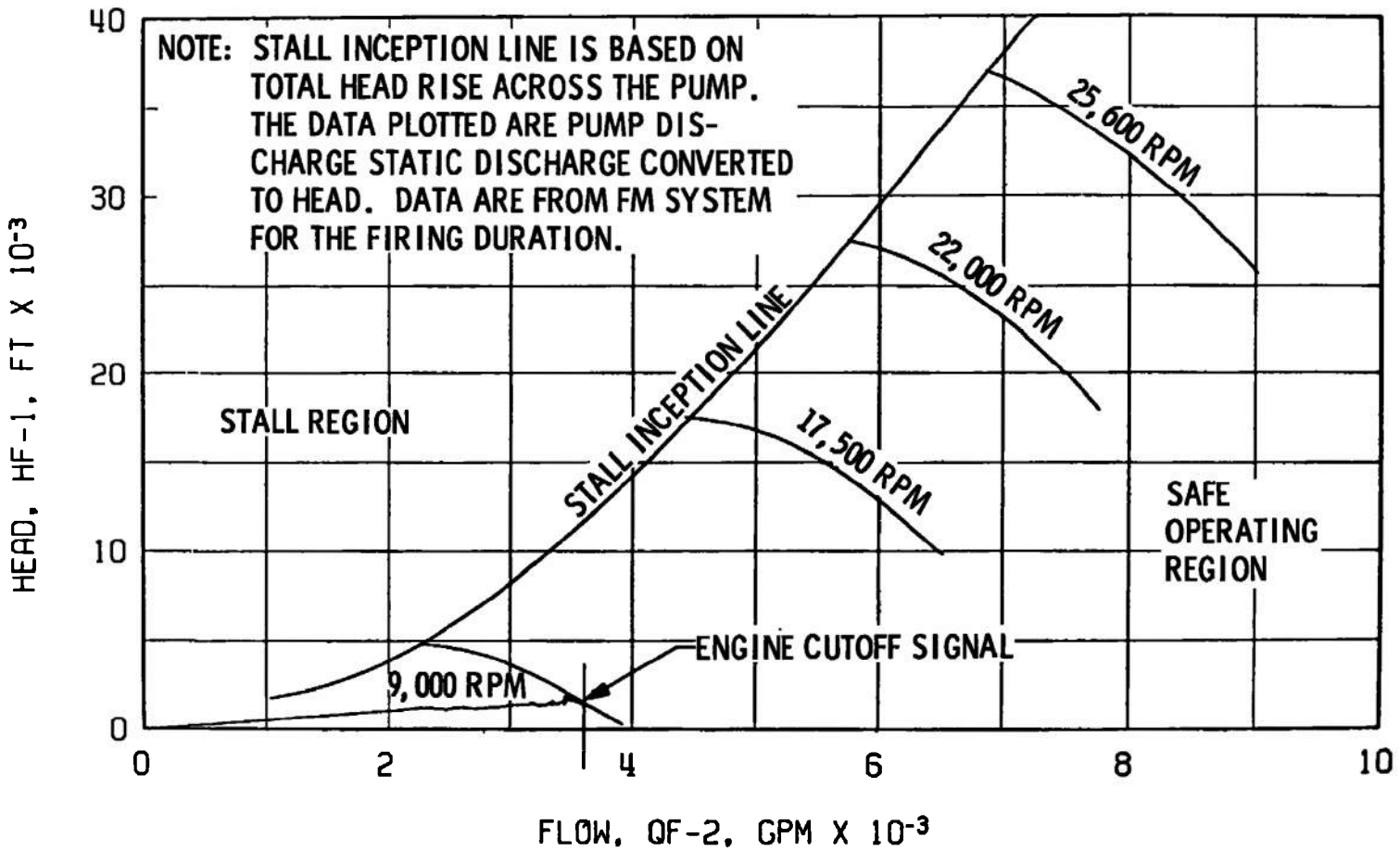

Fig. 31 Fuel Pump Start Transient Performance, Firing 09F

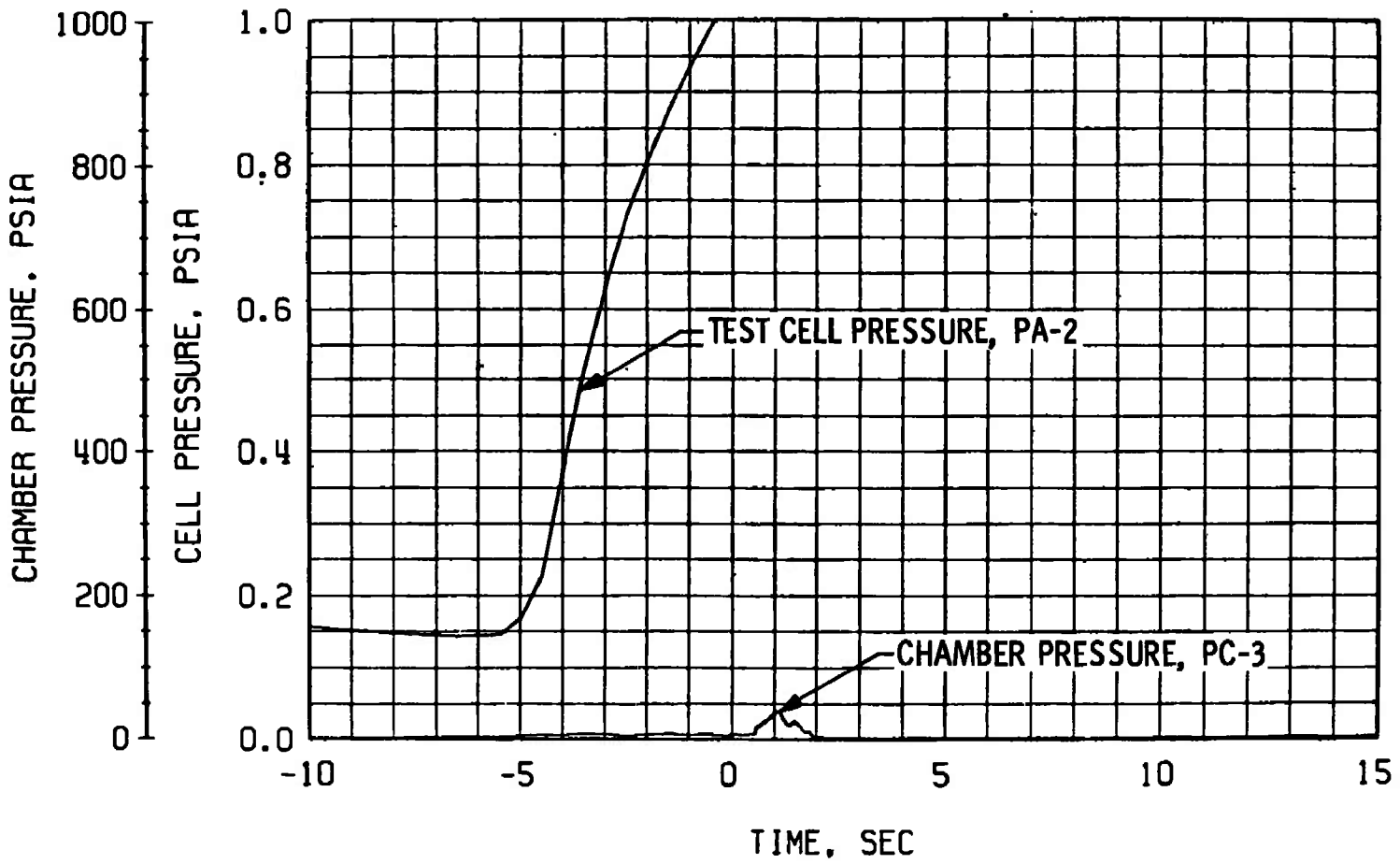
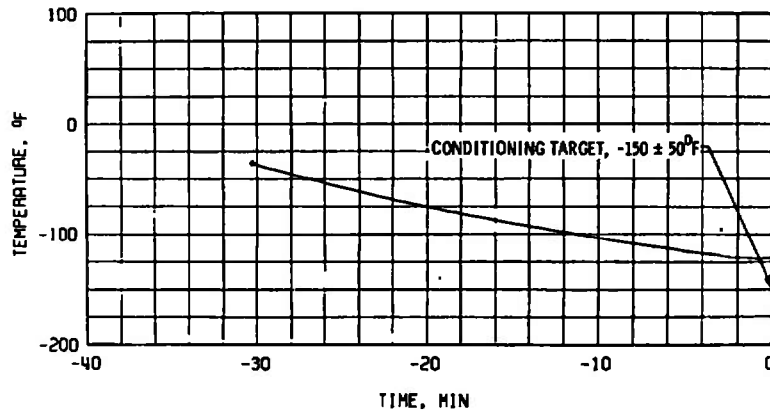
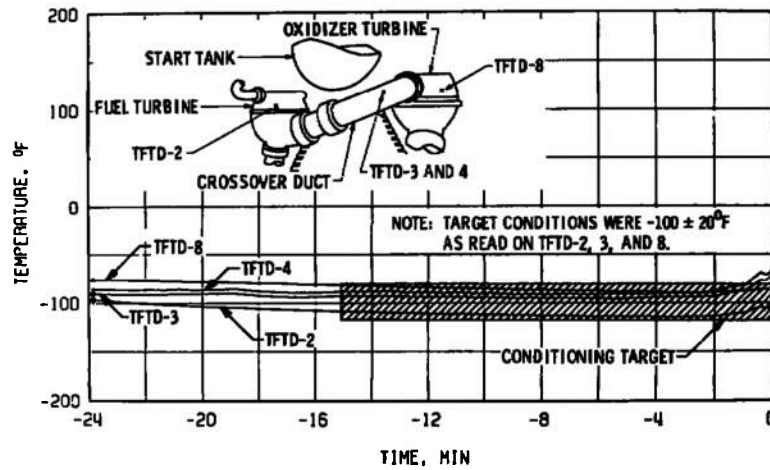

Fig. 32 Engine Ambient and Combustion Chamber Pressure, Firing 09F



a. Main Oxidizer Valve Second-Stage Actuator, TSOVC-1



b. Crossover Duct, TTFD

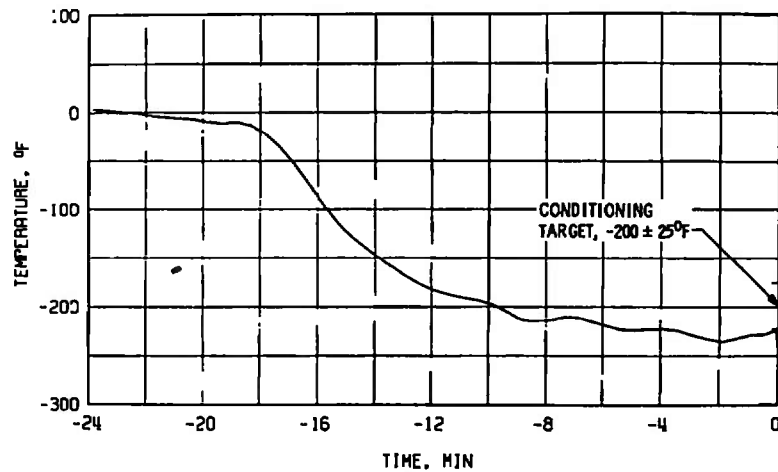

c. Thrust Chamber, TTC-1P

Fig. 33 Thermal Conditioning History of Engine Components, Firing 10A

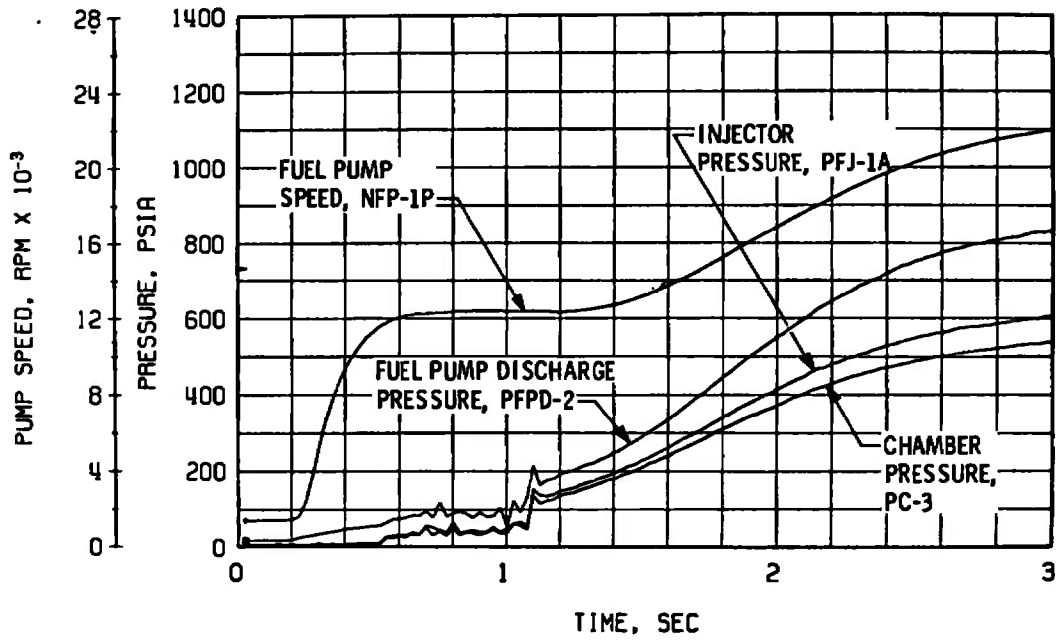

a. Thrust Chamber Fuel System, Start

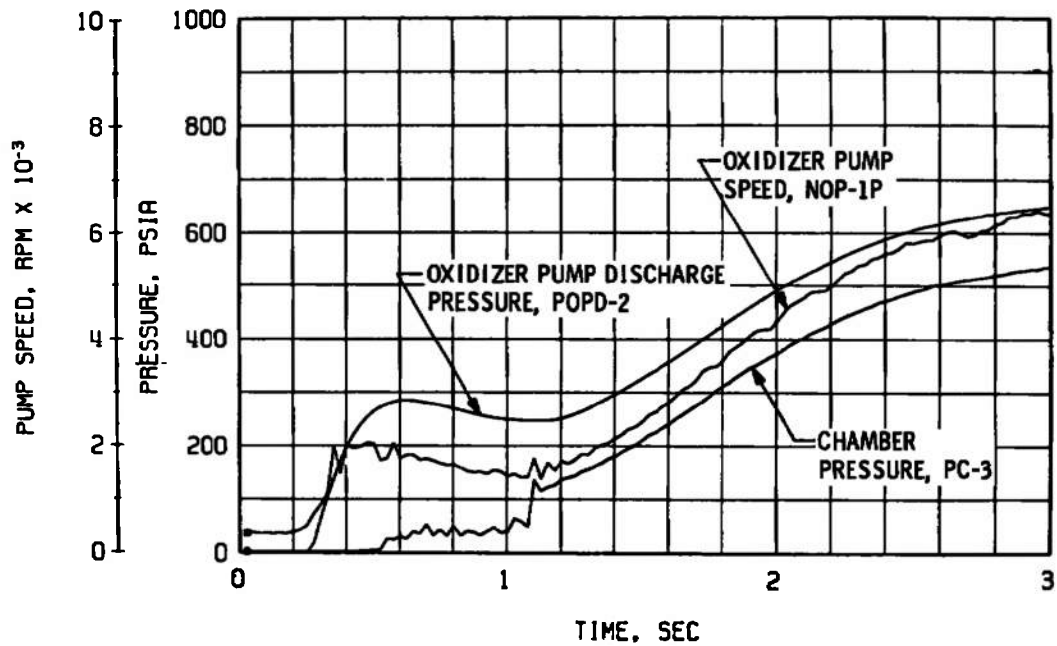

b. Thrust Chamber Oxidizer System, Start

Fig. 34 Engine Transient Operation, Firing 10A

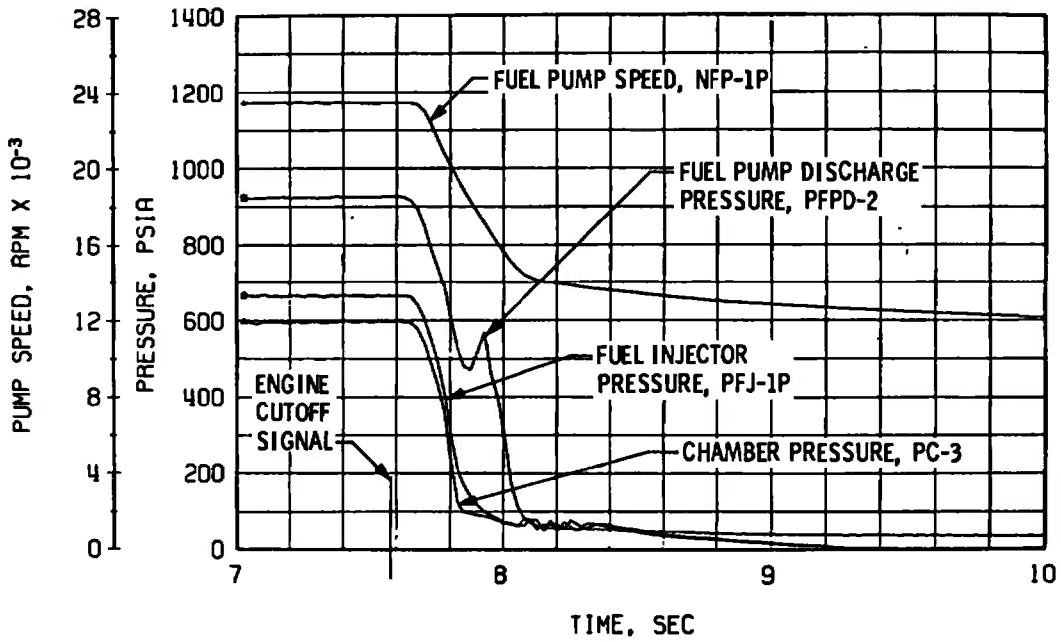

c. Thrust Chamber Fuel System, Shutdown

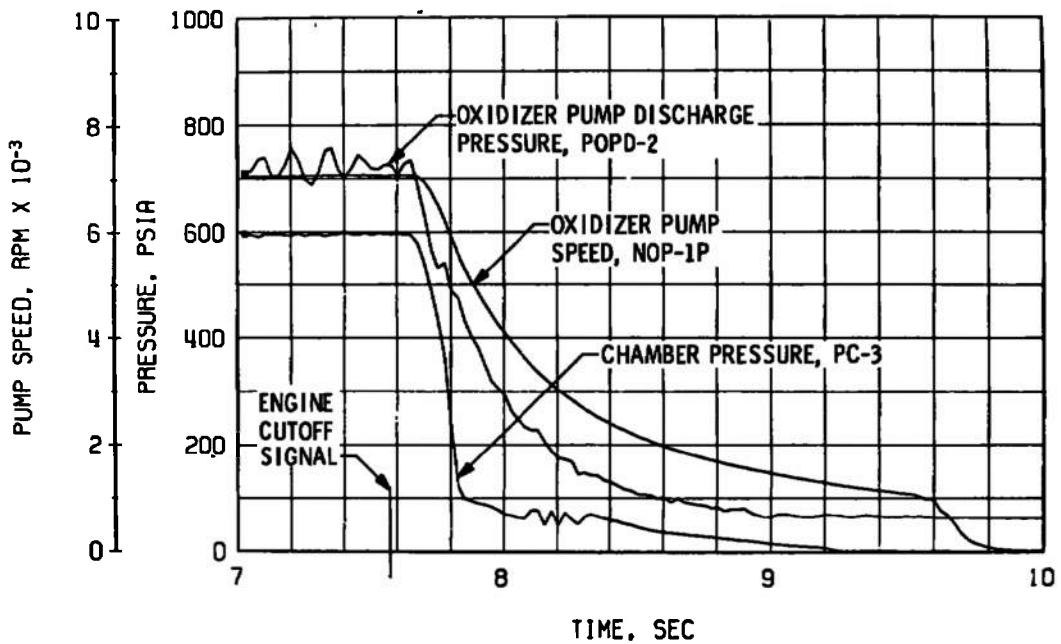

d. Thrust Chamber Oxidizer System, Shutdown

Fig. 34 Continued

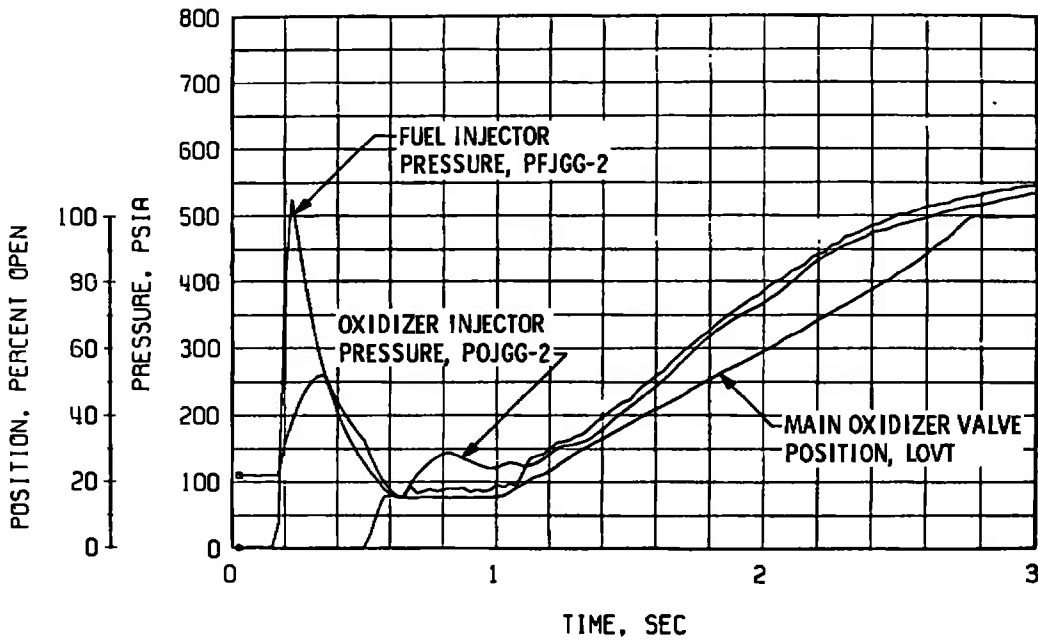

e. Gas Generator Injector Pressures and Main Oxidizer Valve Position, Start

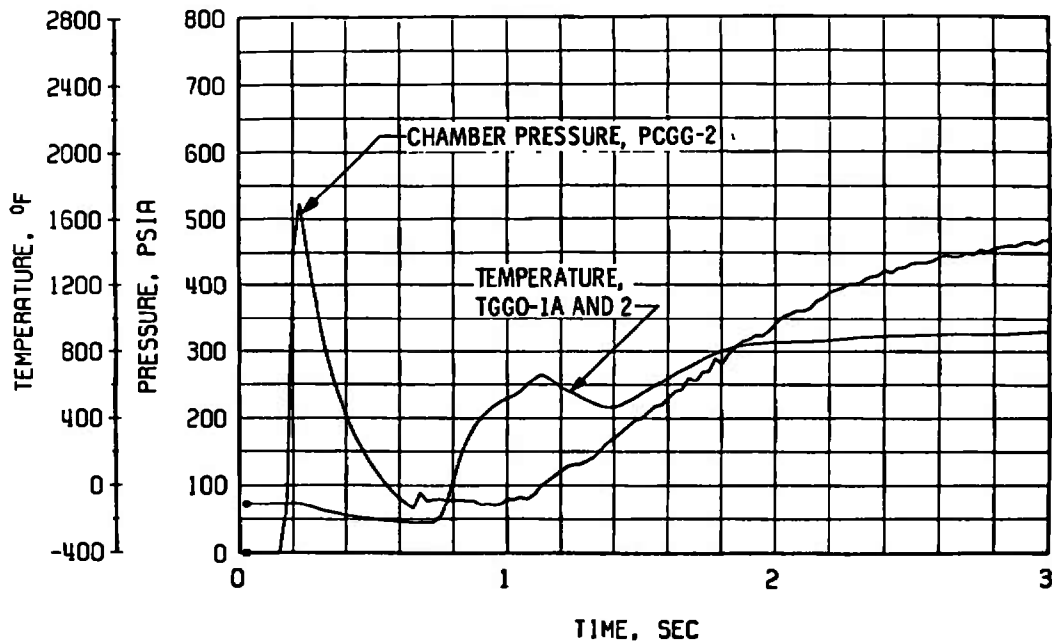

f. Gas Generator Chamber Pressure and Temperature, Start

Fig. 34 Continued

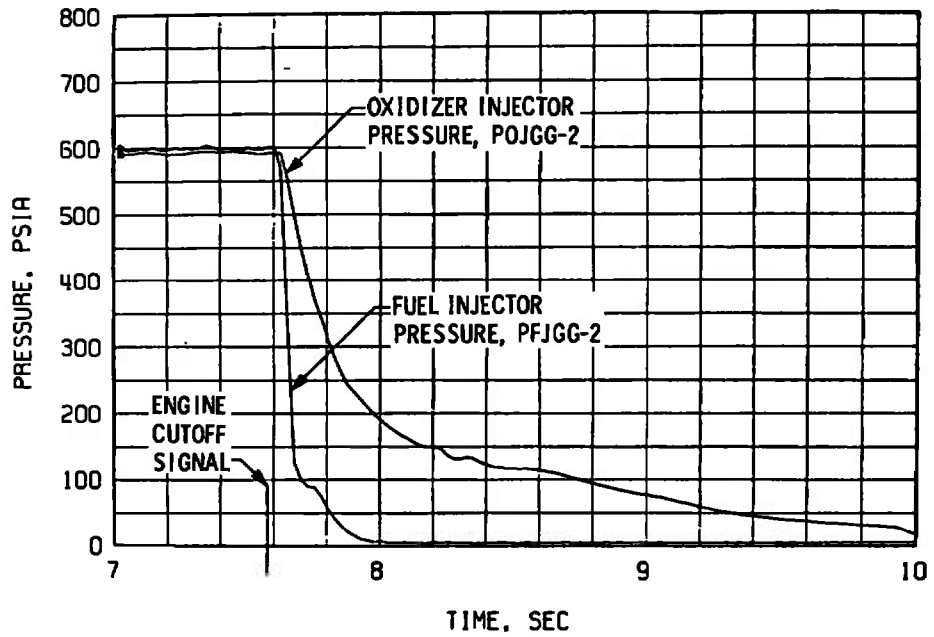

g. Gas Generator Injector Pressures, Shutdown

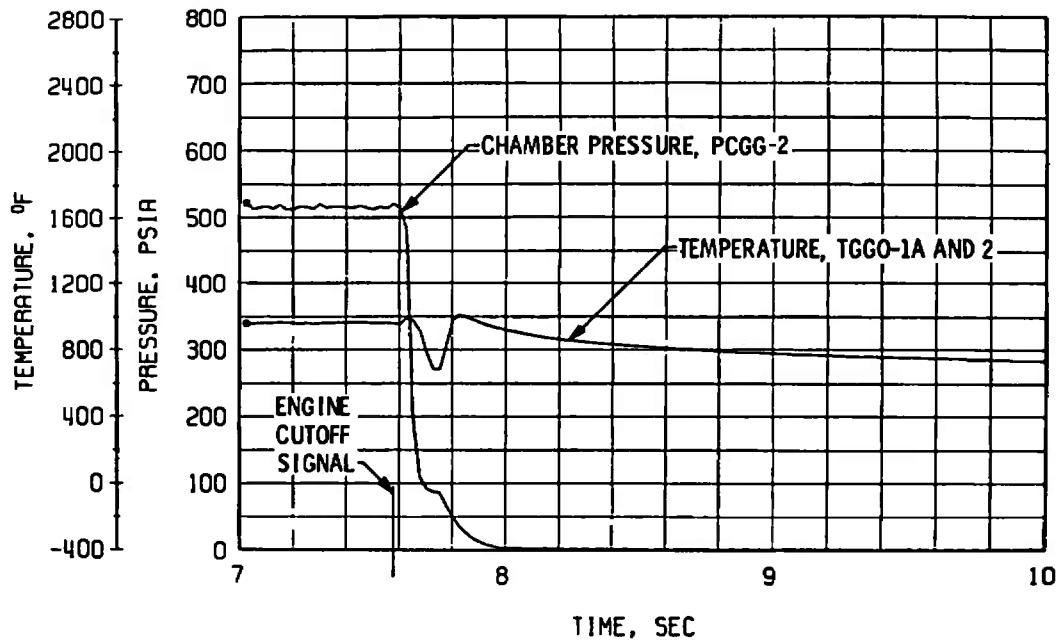

h. Gas Generator Chamber Pressure and Temperature, Shutdown

Fig. 34 Concluded

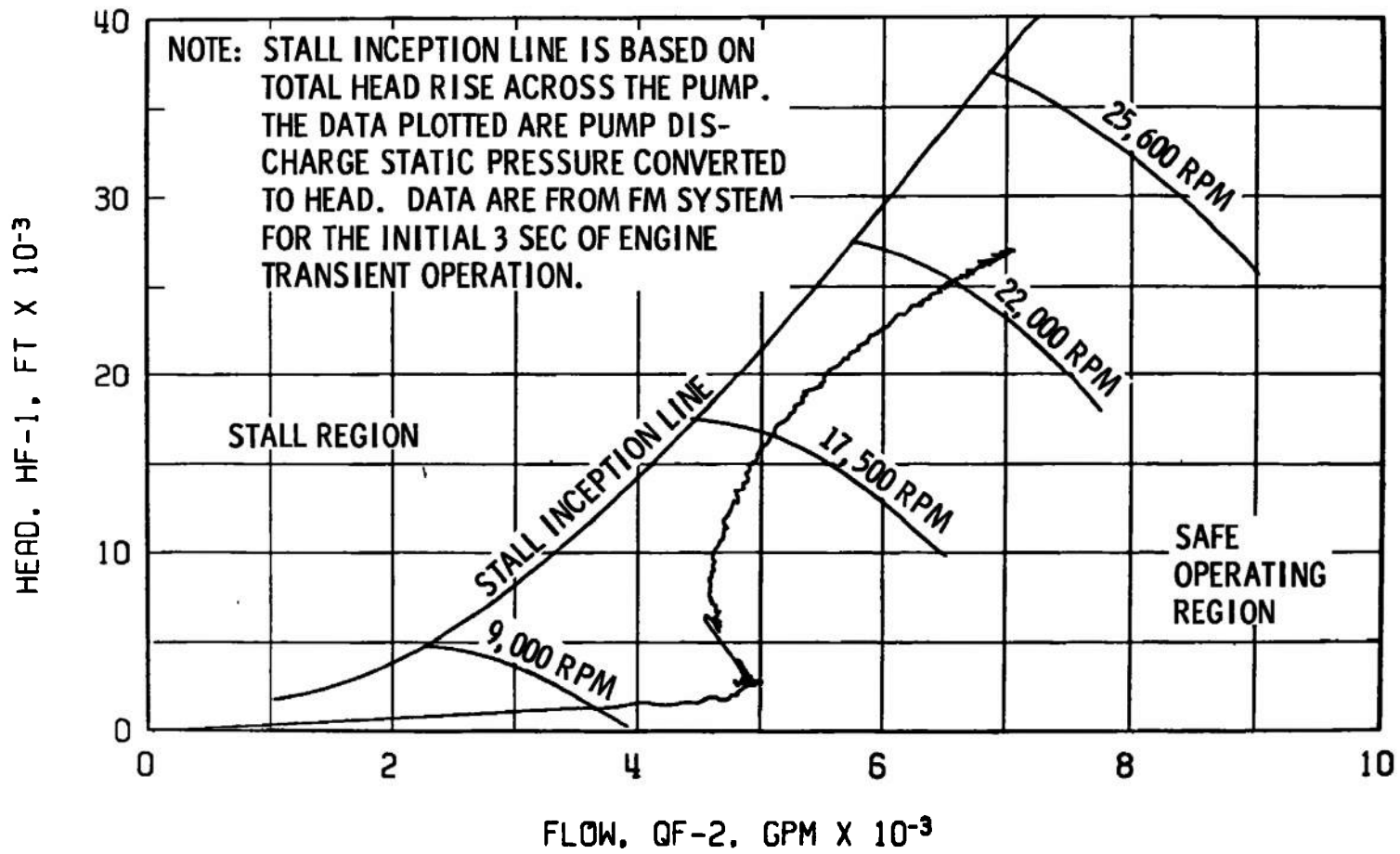

Fig. 35 Fuel Pump Start Transient Performance, Firing 10A

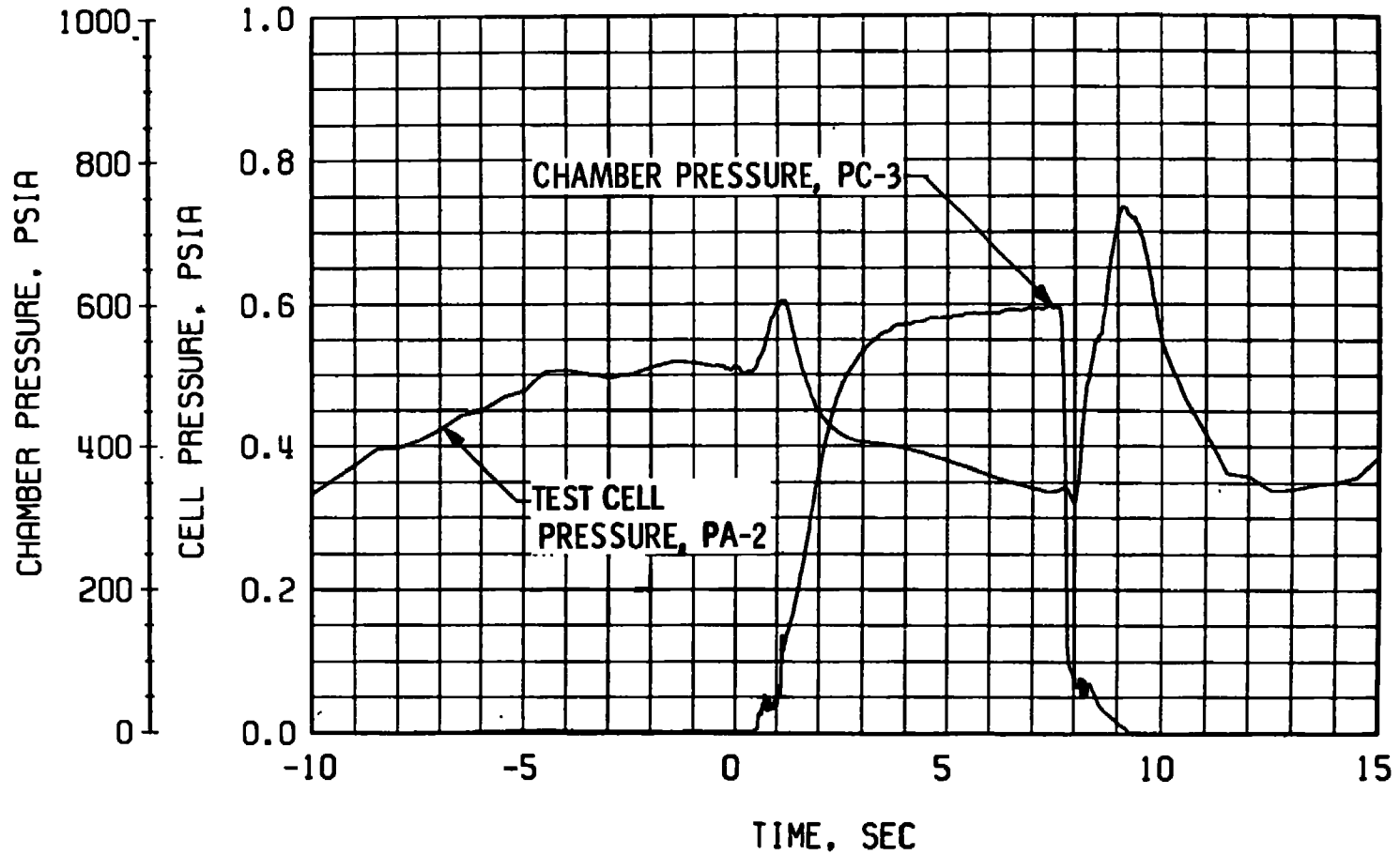
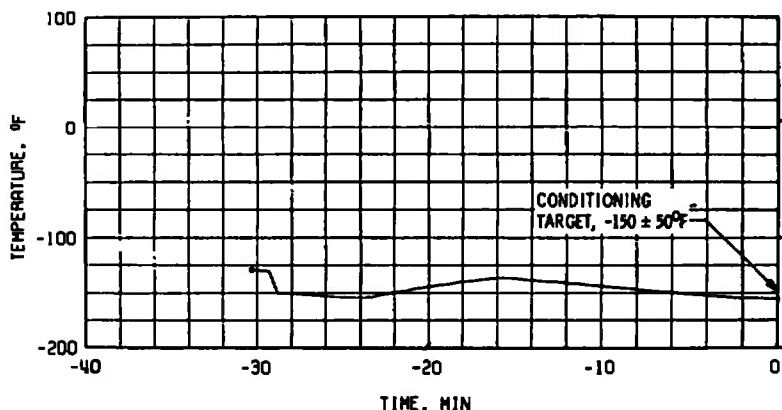
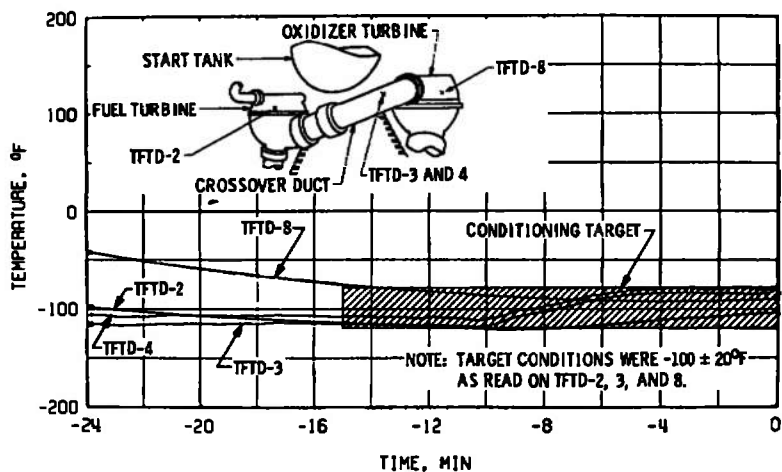

Fig. 36 Engine Ambient and Combustion Chamber Pressure, Firing 10A



a. Main Oxidizer Valve Second-Stage Actuator, TSOVC-1



b. Crossover Duct, TTFD

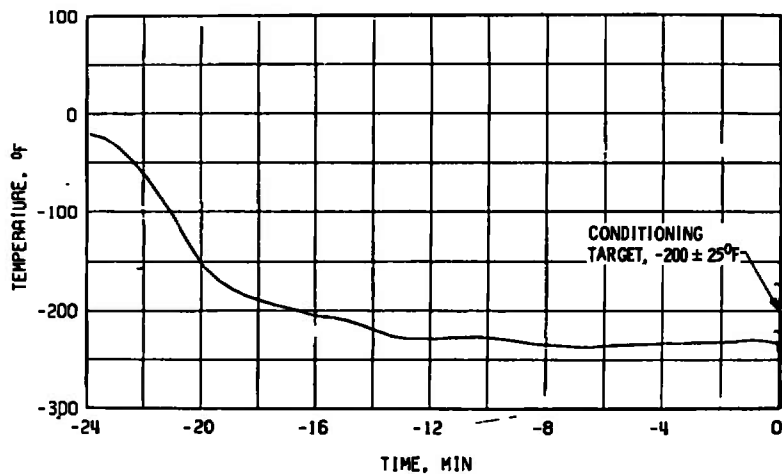

c. Thrust Chamber, TTC-1P

Fig. 37 Thermal Conditioning History of Engine Components, Firing 10B

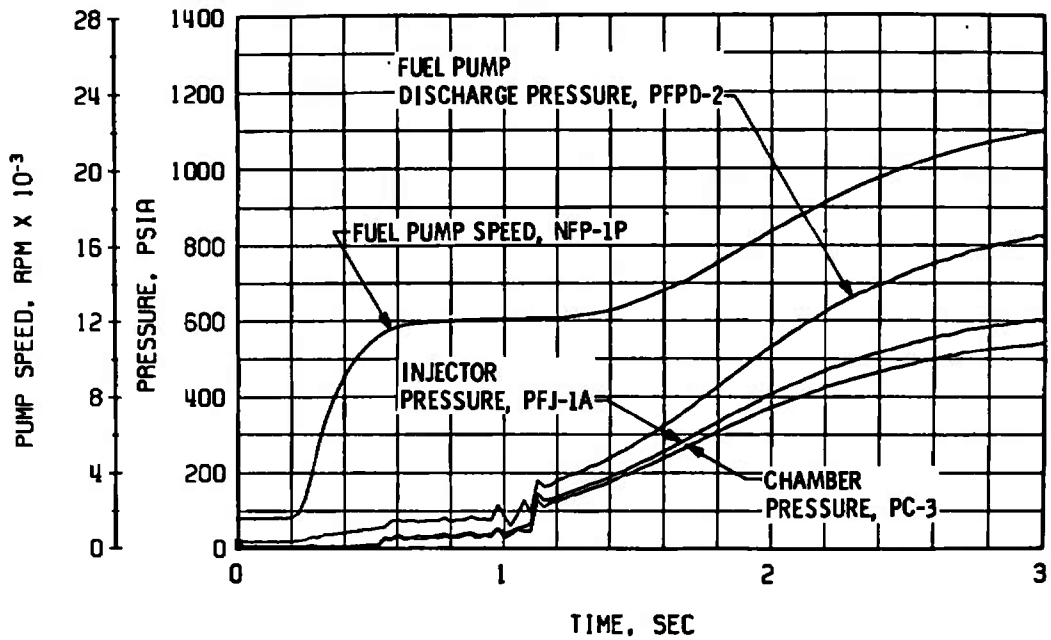

a. Thrust Chamber Fuel System, Start

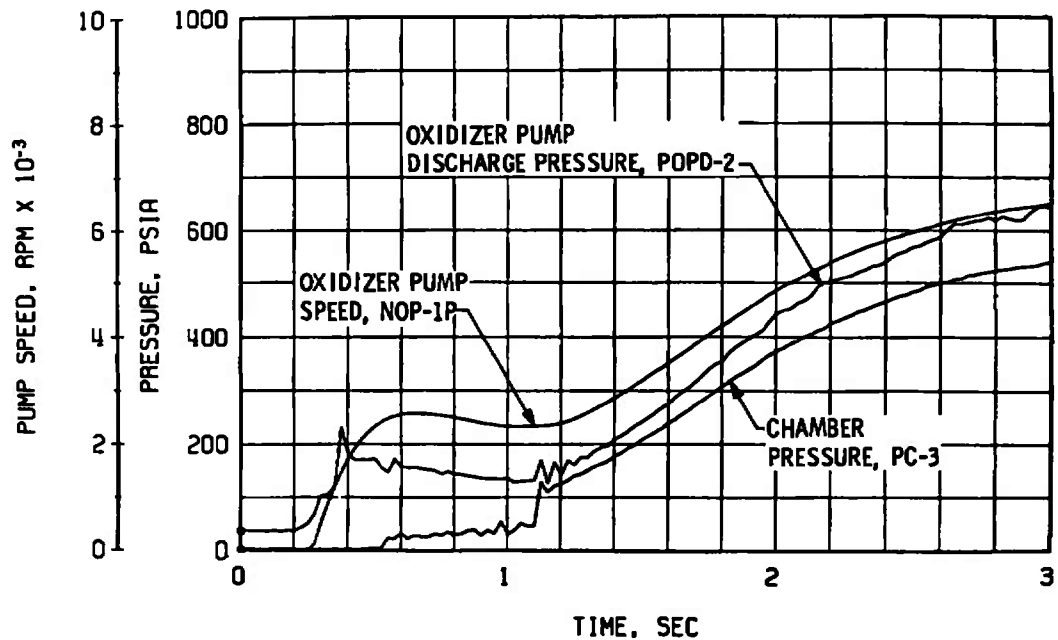

b. Thrust Chamber Oxidizer System, Start

Fig. 38 Engine Transient Operation, Firing 10B

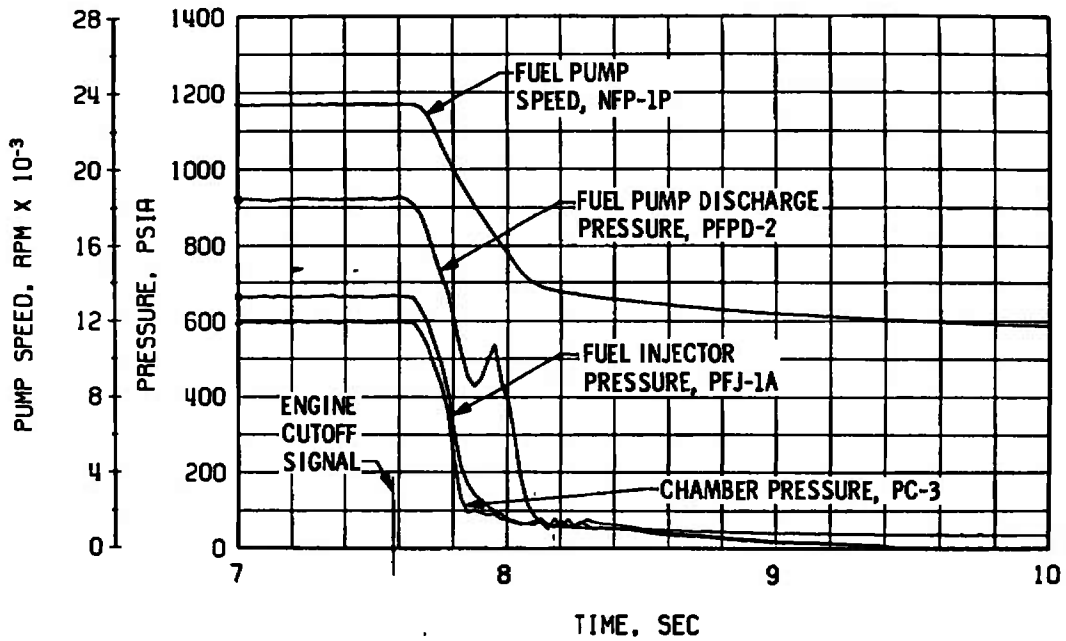

c. Thrust Chamber Fuel System, Shutdown

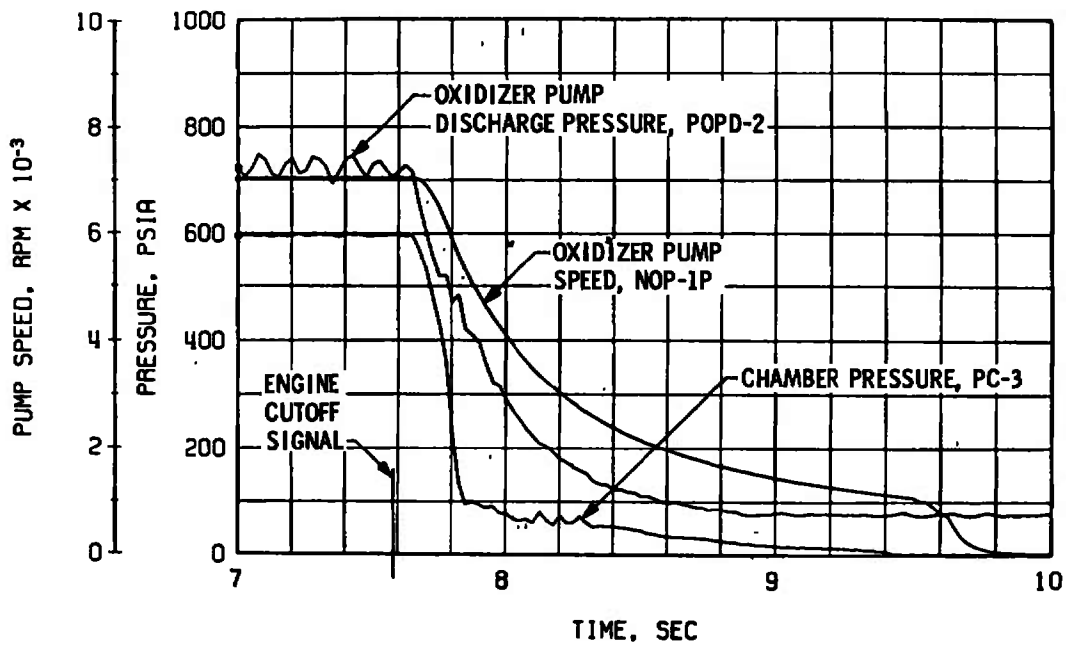

d. Thrust Chamber Oxidizer System, Shutdown

Fig. 38 Continued

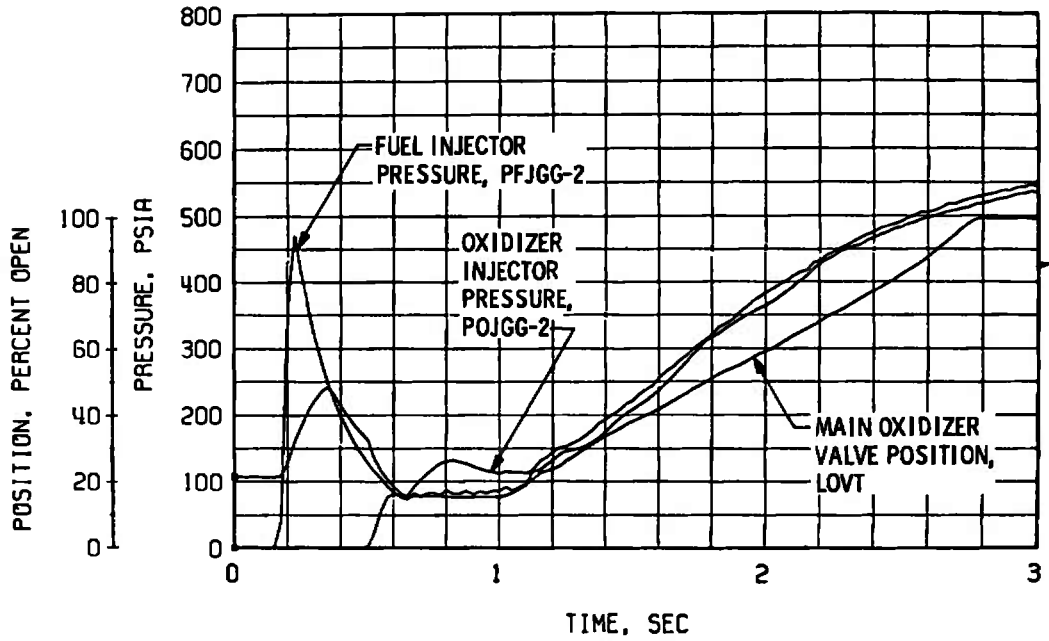

e. Gas Generator Injector Pressures and Main Oxidizer Valve Position, Start

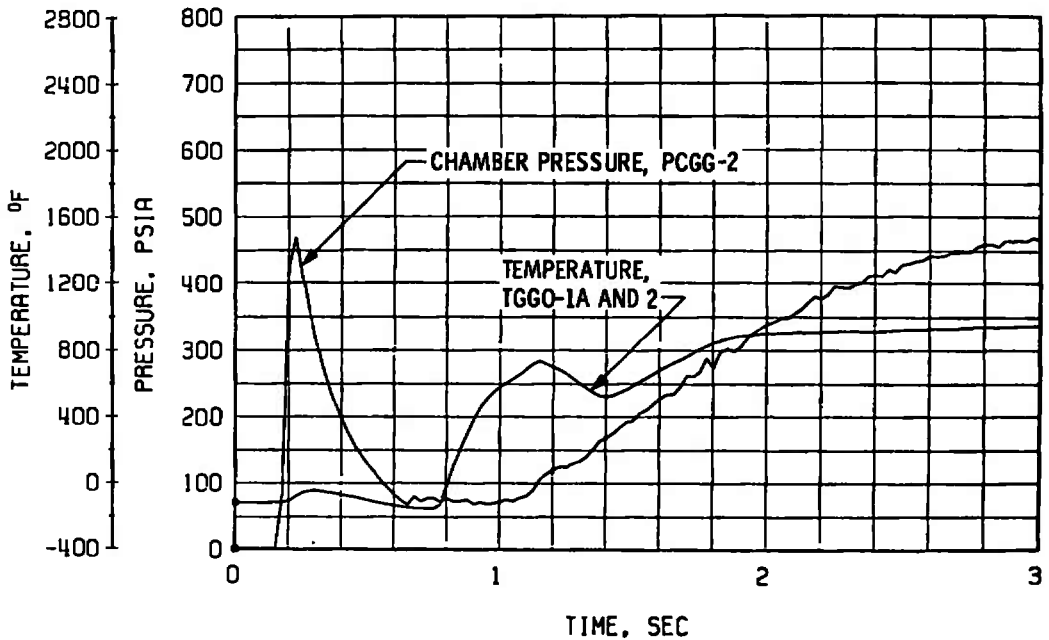

f. Gas Generator Chamber Pressure and Temperature, Start

Fig. 38 Continued

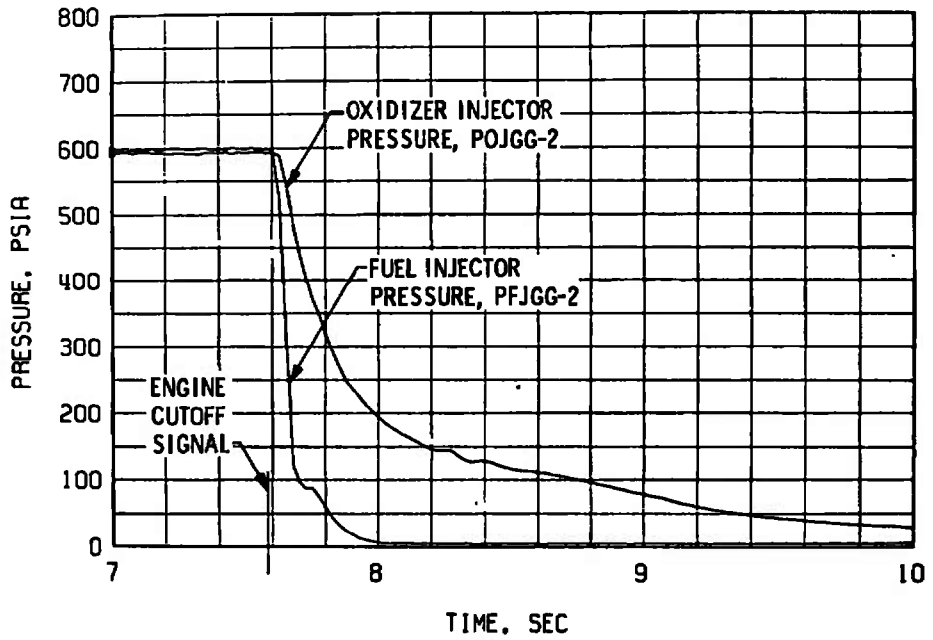

g. Gas Generator Injector Pressures, Shutdown

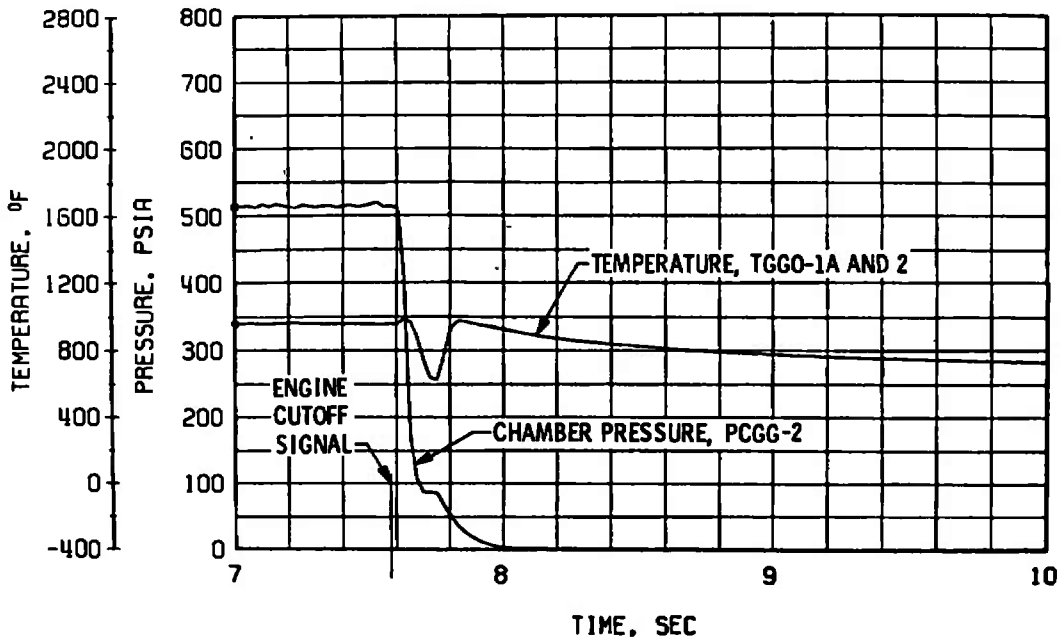

h. Gas Generator Chamber Pressure and Temperature, Shutdown

Fig. 38 Concluded

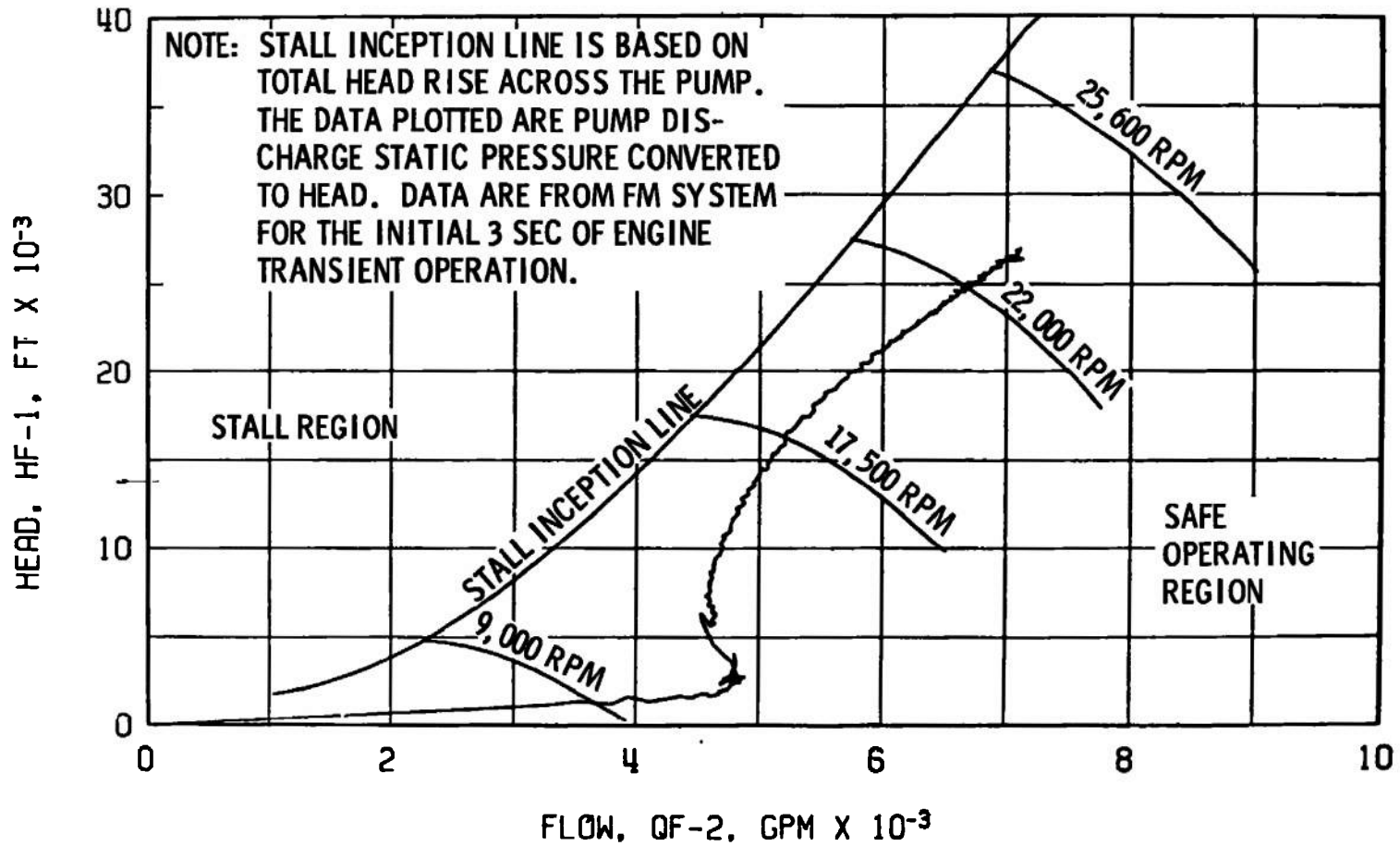

Fig. 39 Fuel Pump Start Transient Performance, Firing 10B

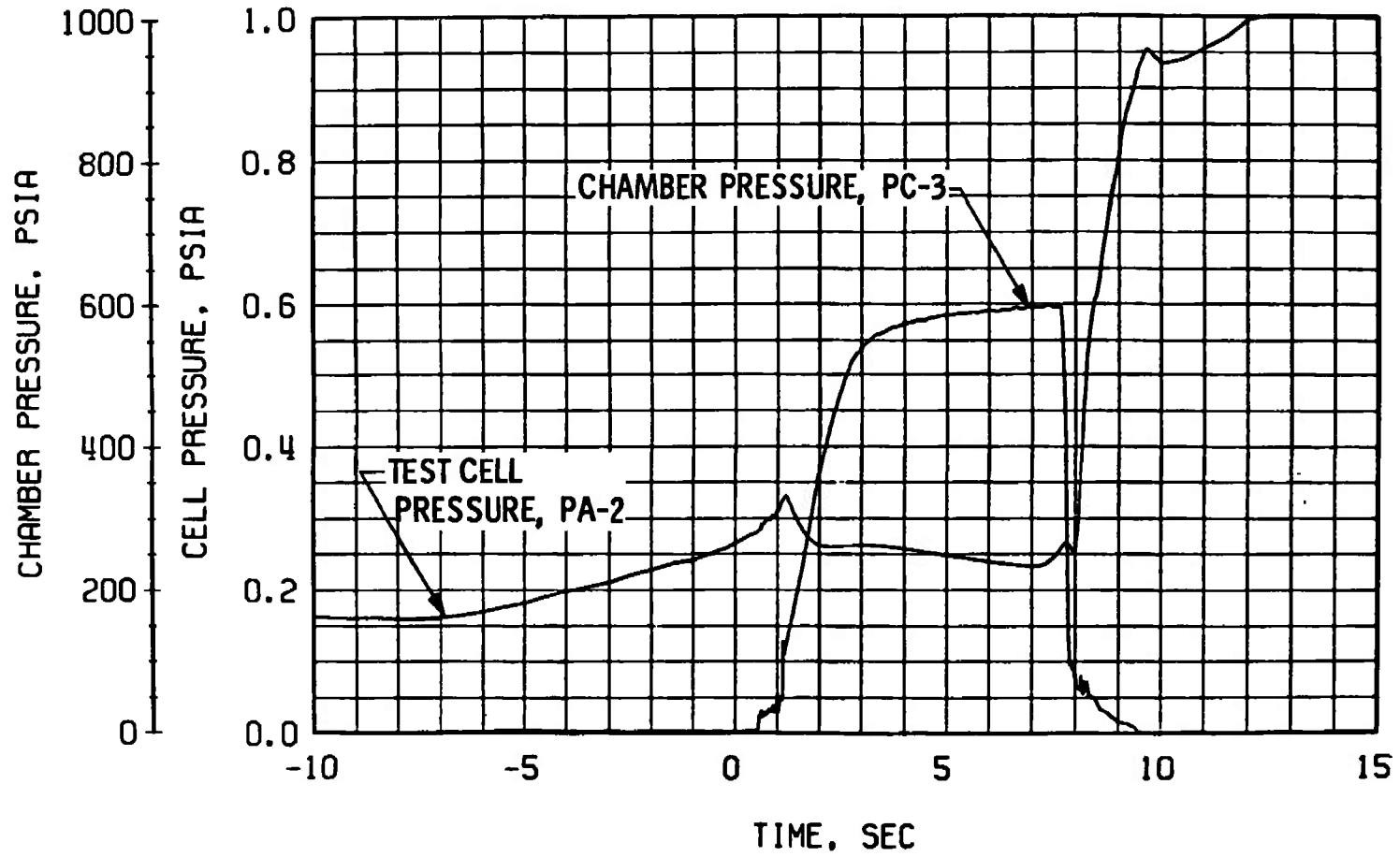
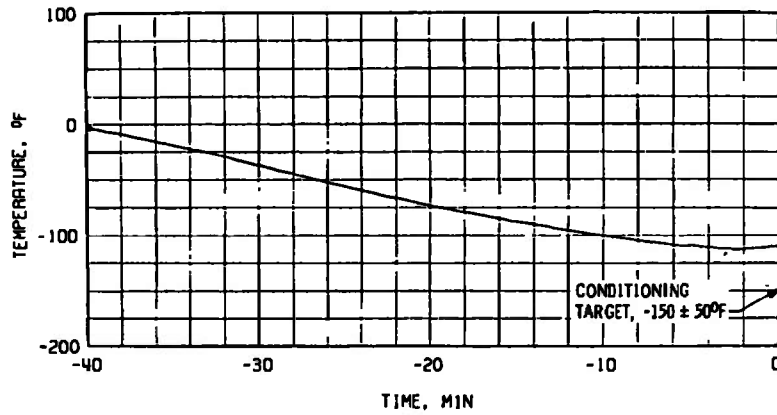
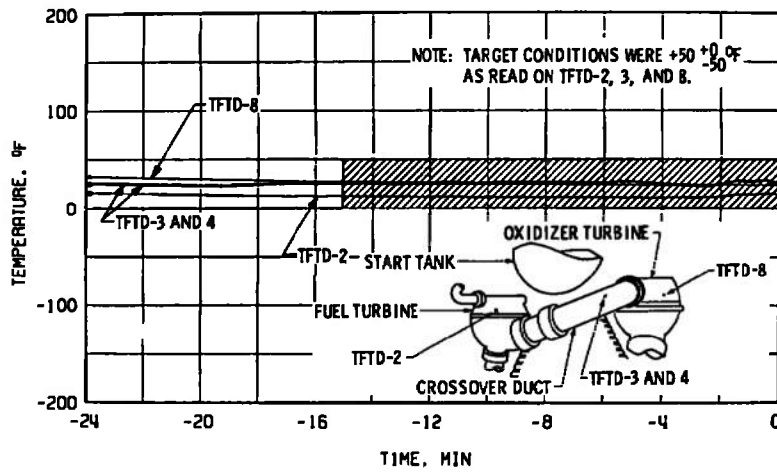

Fig. 40 Engine Ambient and Combustion Chamber Pressure, Firing 10B



a. Main Oxidizer Valve Second-Stage Actuator, TSOVC-1



b. Crossover Duct, TFTD

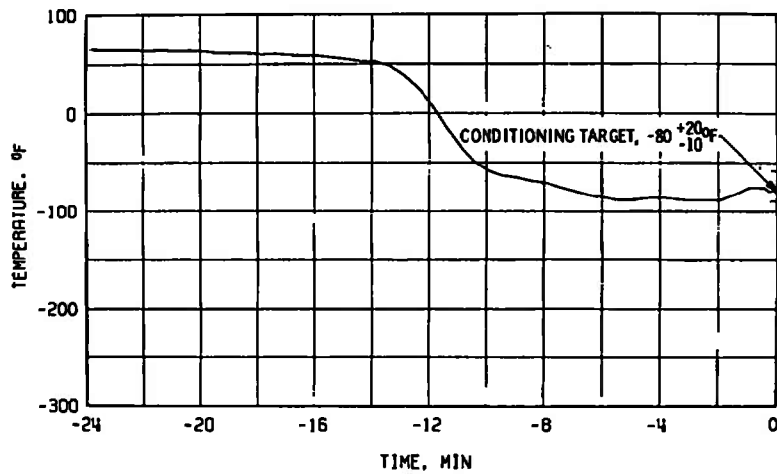

c. Thrust Chamber, TTC-1P

Fig. 41 Thermal Conditioning History of Engine Components, Firing 11A

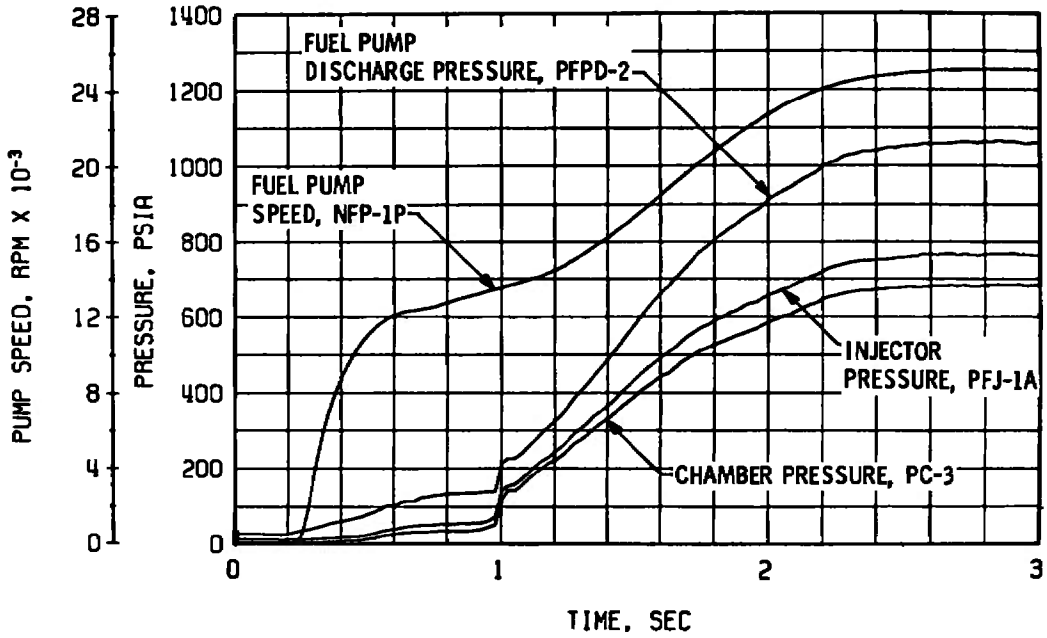

a. Thrust Chamber Fuel System, Start

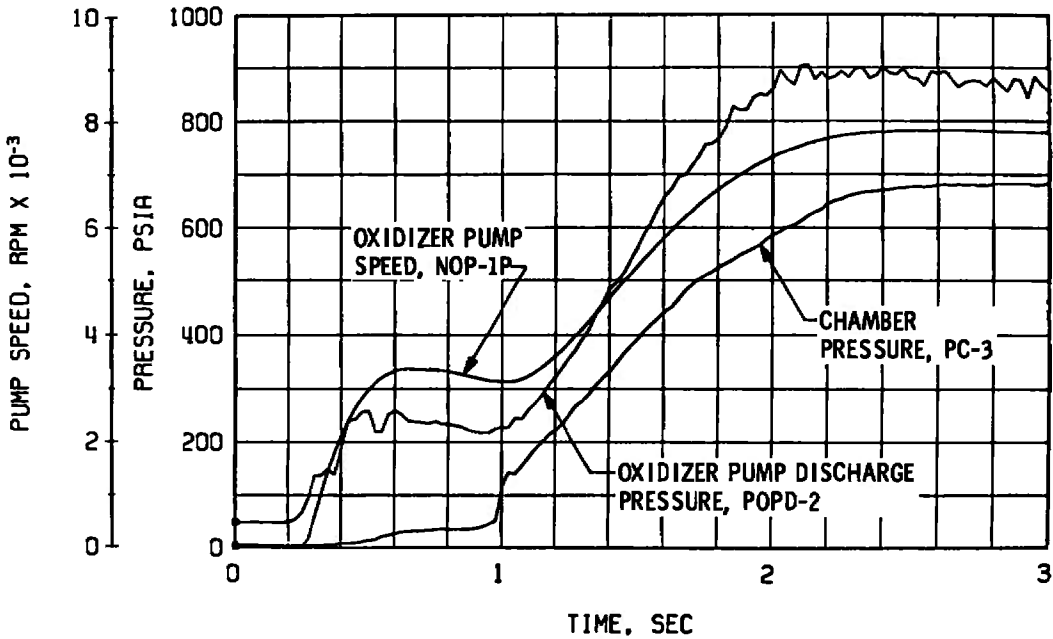

b. Thrust Chamber Oxidizer System, Start

Fig. 42 Engine Transient Operation, Firing 11A

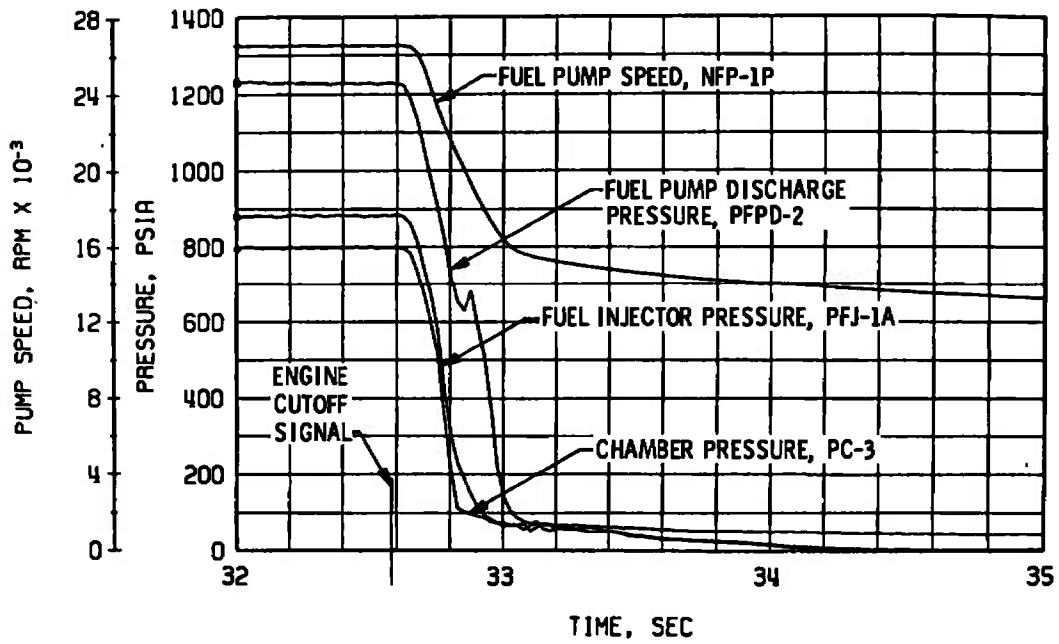

c. Thrust Chamber Fuel System, Shutdown

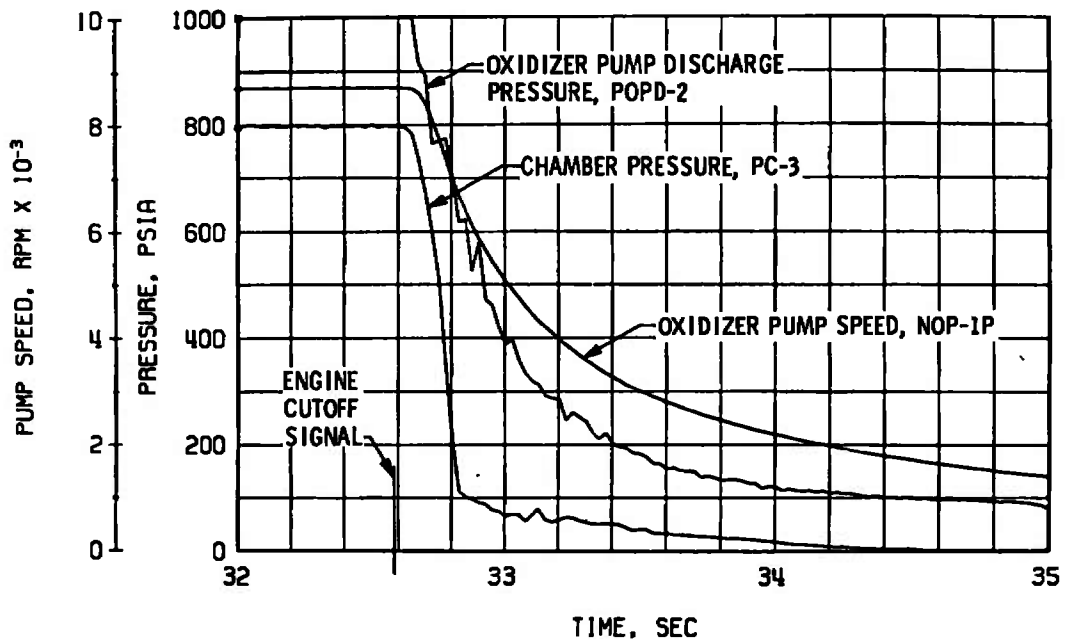

d. Thrust Chamber Oxidizer System, Shutdown

Fig. 42 Continued

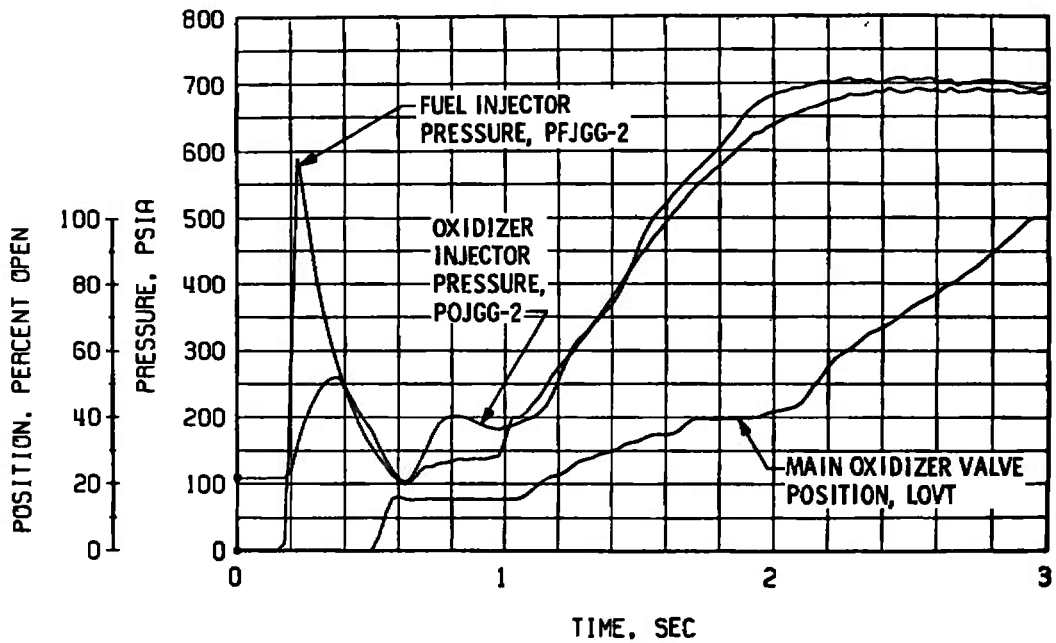

e. Gas Generator Injector Pressures and Main Oxidizer Valve Position, Start

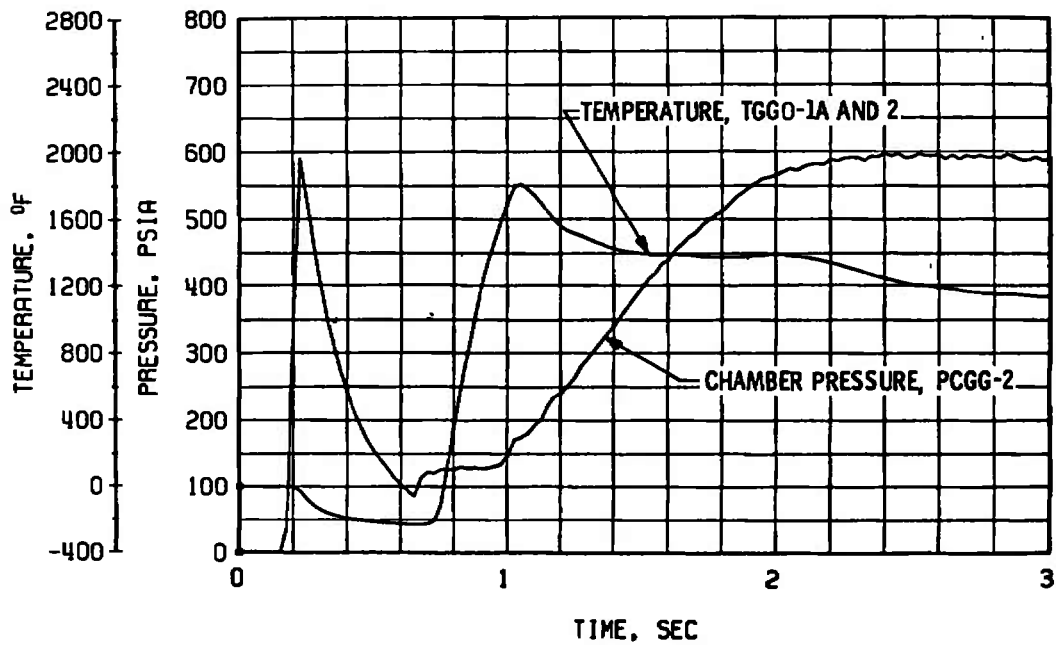

f. Gas Generator Chamber Pressure and Temperature, Start

Fig. 42 Continued

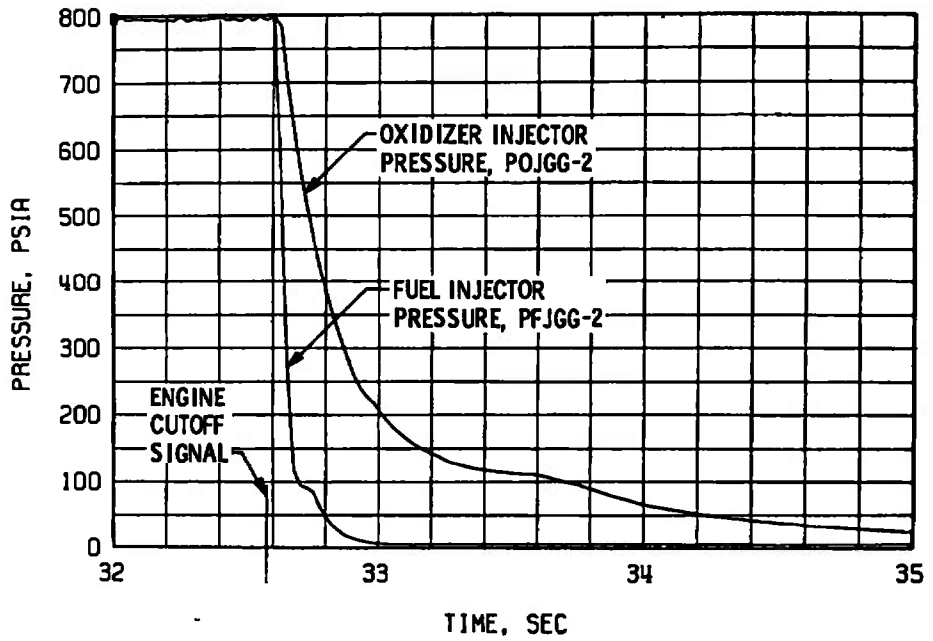

g. Gas Generator Injector Pressures, Shutdown

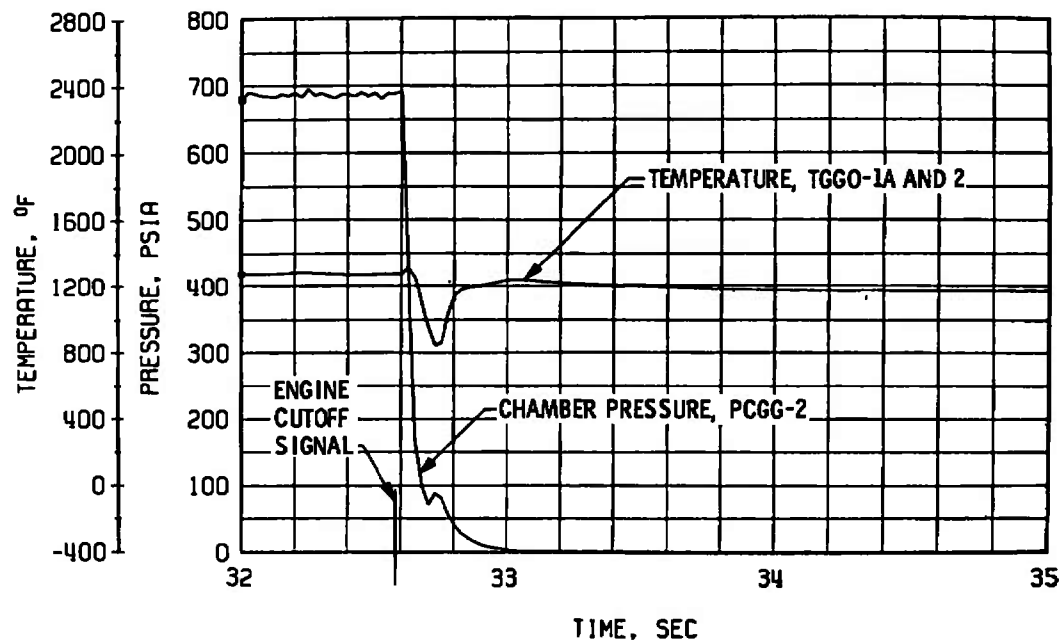

h. Gas Generator Chamber Pressure and Temperature, Shutdown

Fig. 42 Concluded

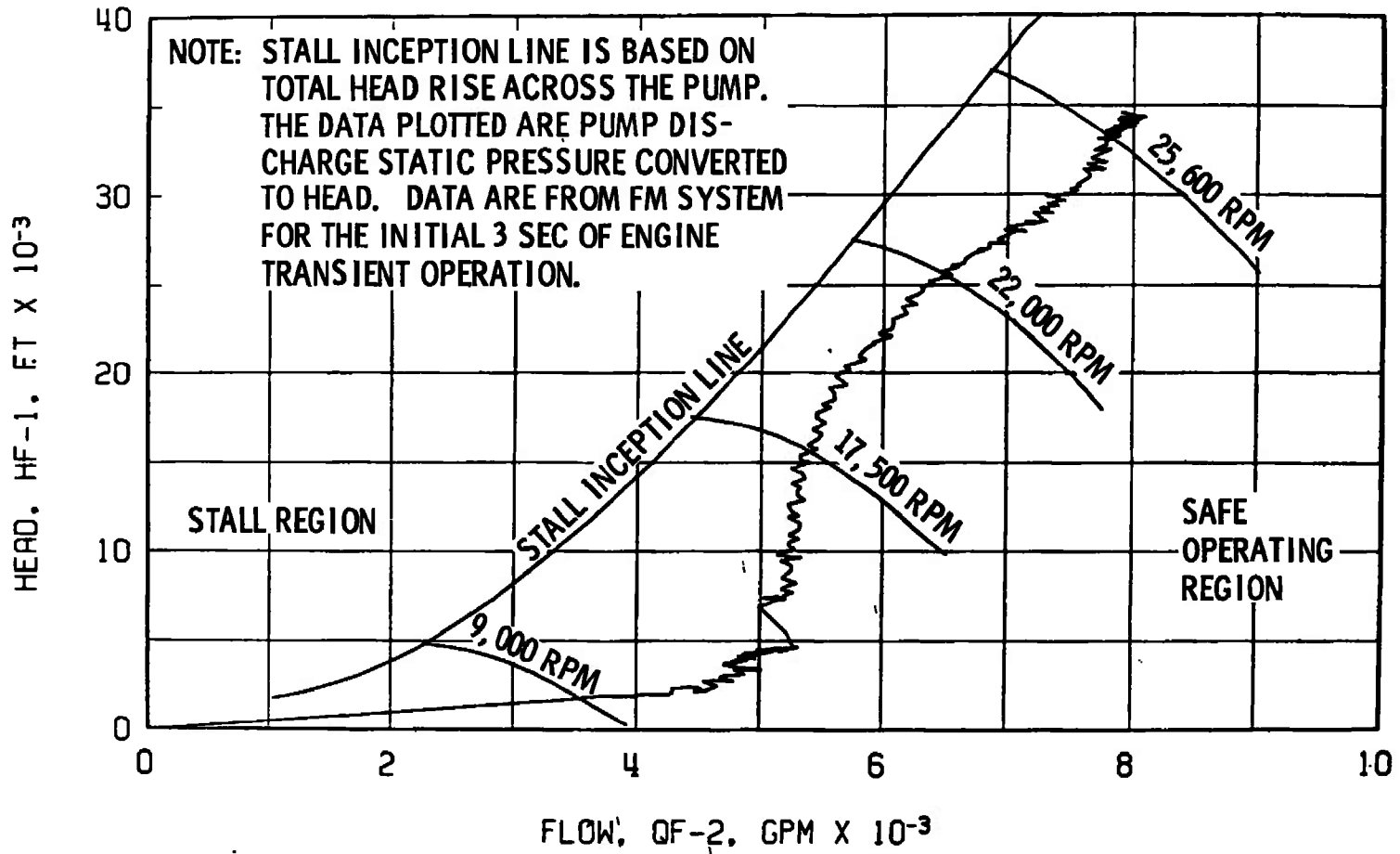

Fig. 43 Fuel Pump Start Transient Performance, Firing 11A

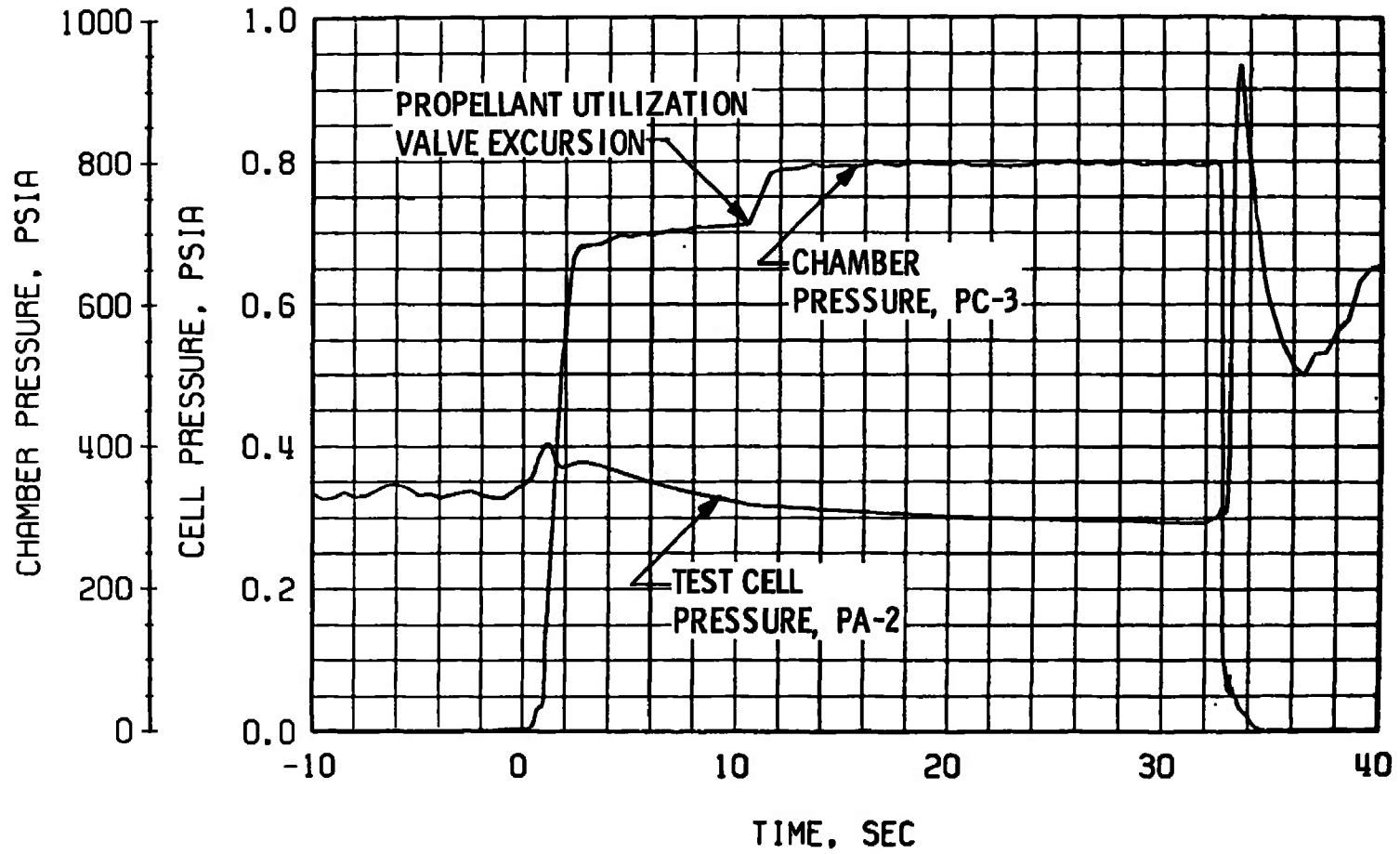
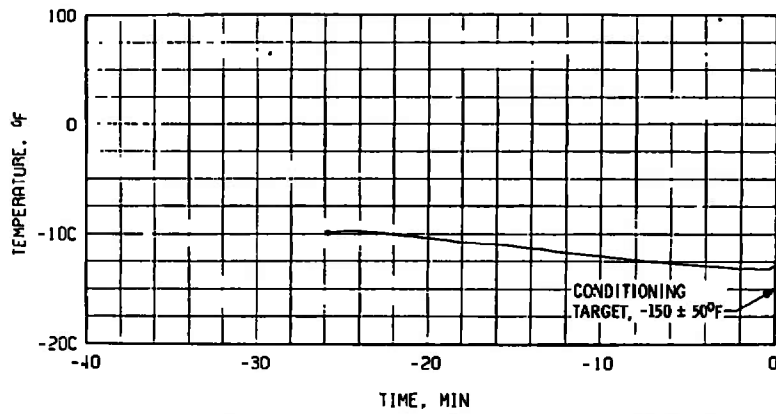
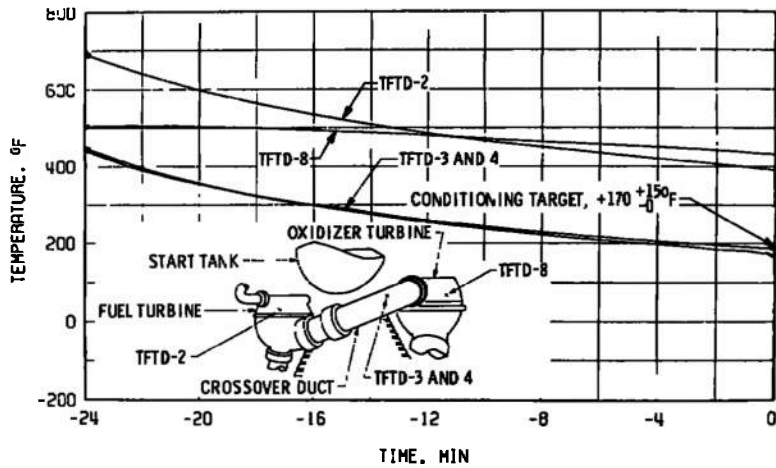

Fig. 44 Engine Ambient and Combustion Chamber Pressure, Firing 11A



a. Main Oxidizer Valve Second-Stage Actuator, TSOVC-1



b. Crossover Duct, TFTD

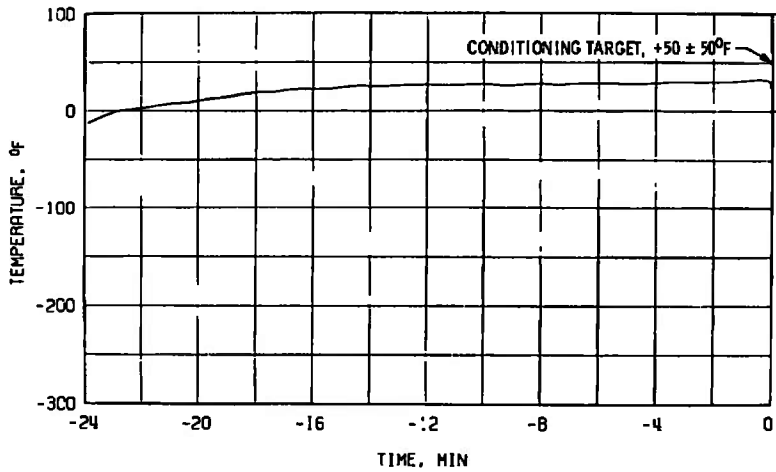

c. Thrust Chamber, TTC-1P

Fig. 45 Thermal Conditioning History of Engine Components, Firing 11B

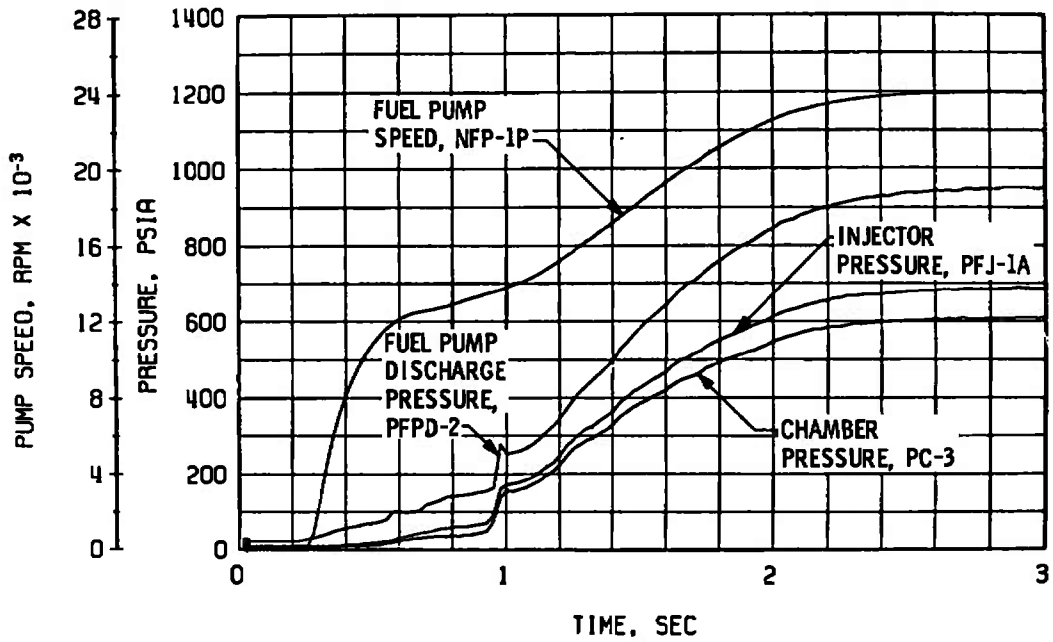

a. Thrust Chamber Fuel System, Start

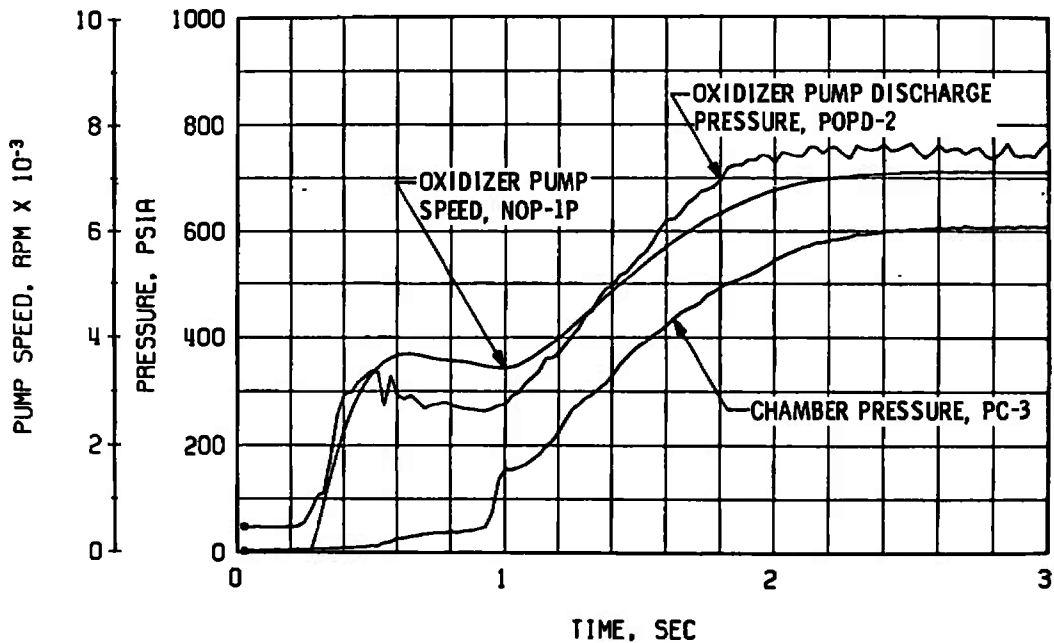

b. Thrust Chamber Oxidizer System, Start
 Fig.-46 Engine Transient Operation, Firing 11B

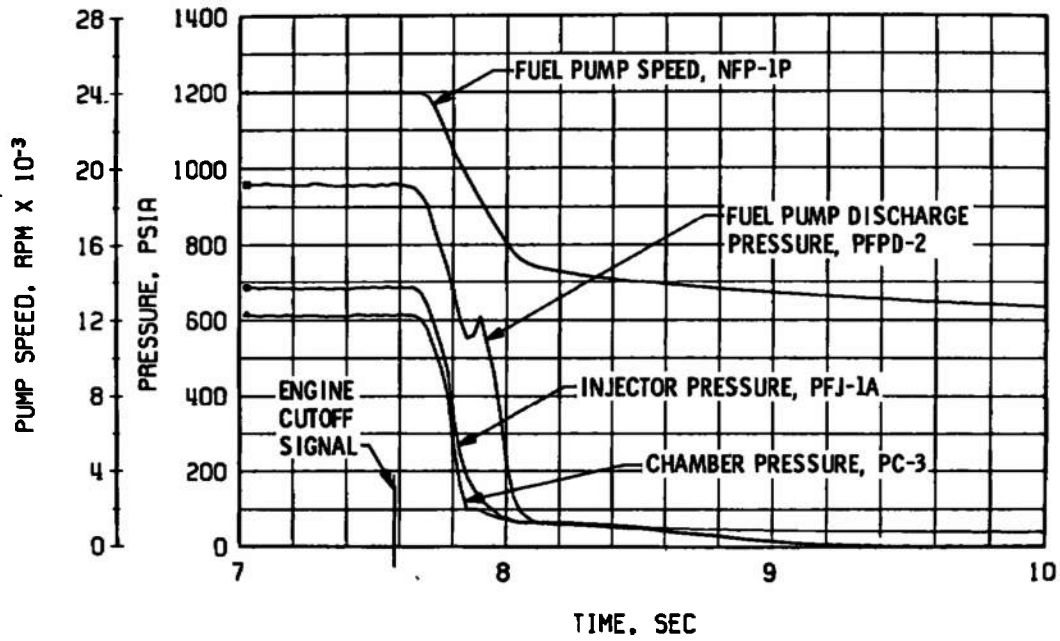

c. Thrust Chamber Fuel System, Shutdown

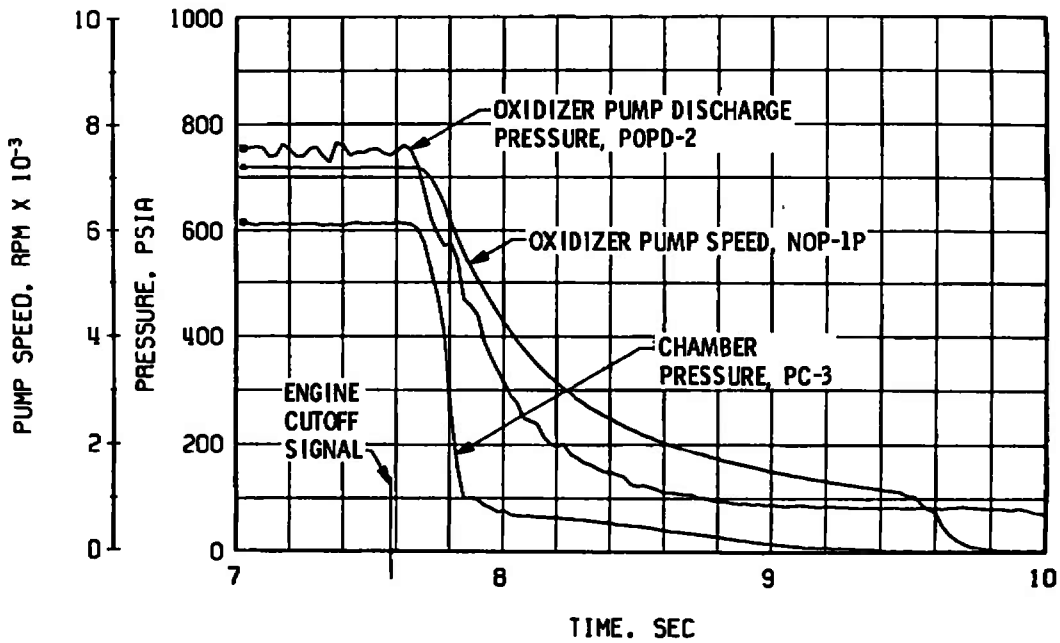

d. Thrust Chamber Oxidizer System, Shutdown

Fig. 46 Continued

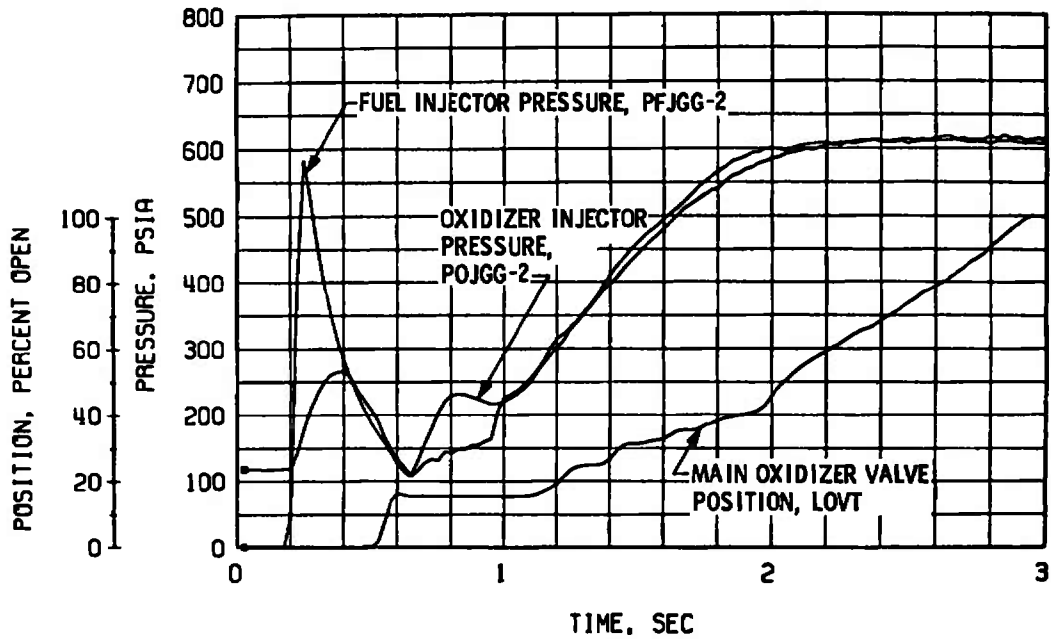

e. Gas Generator Injector Pressures and Main Oxidizer Valve Position, Start

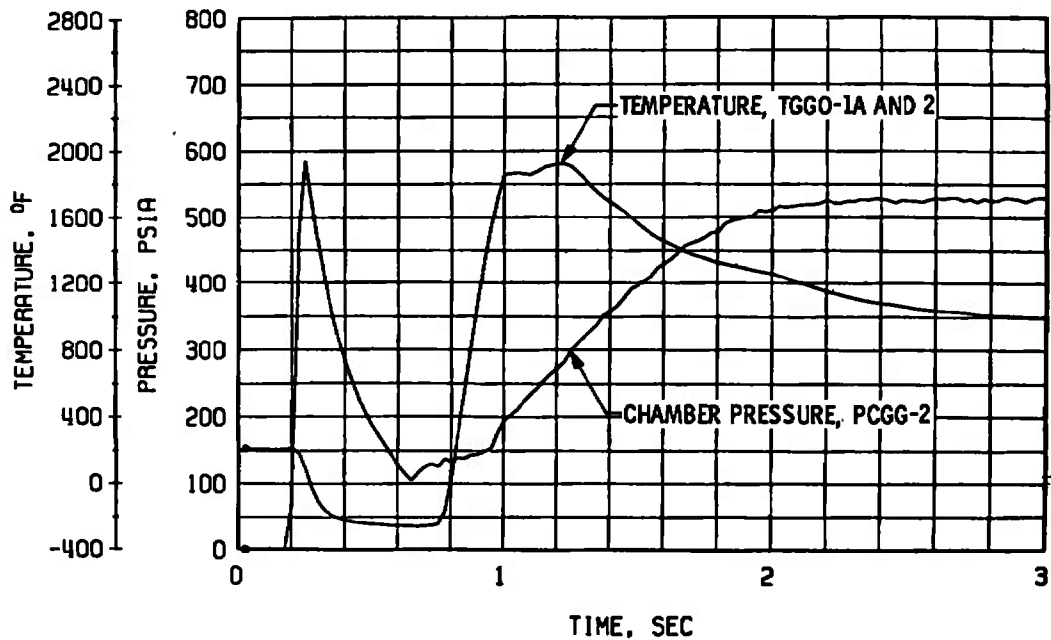

f. Gas Generator Chamber Pressure and Temperature, Start

Fig. 46 Continued

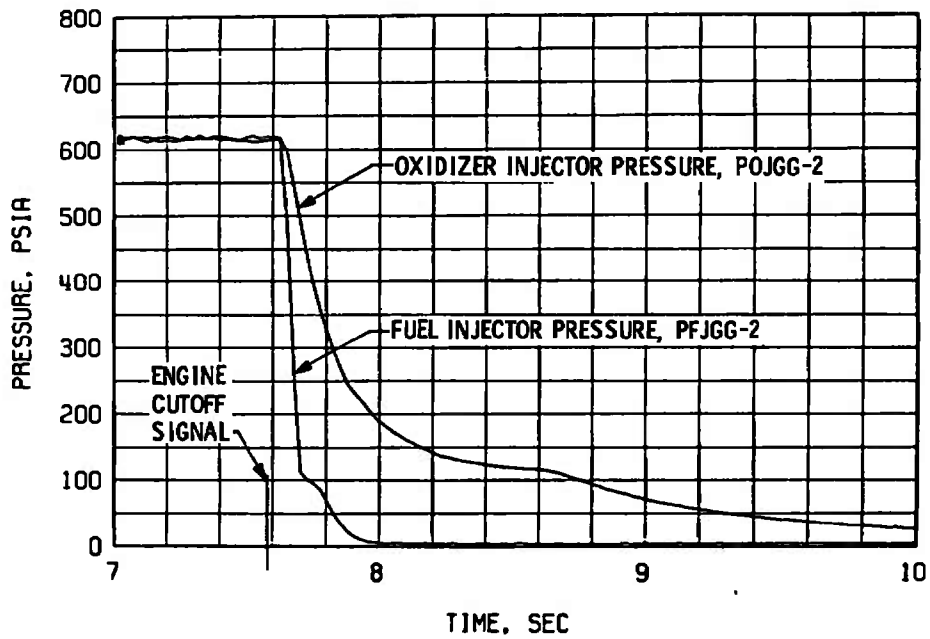

g. Gas Generator Injector Pressures, Shutdown

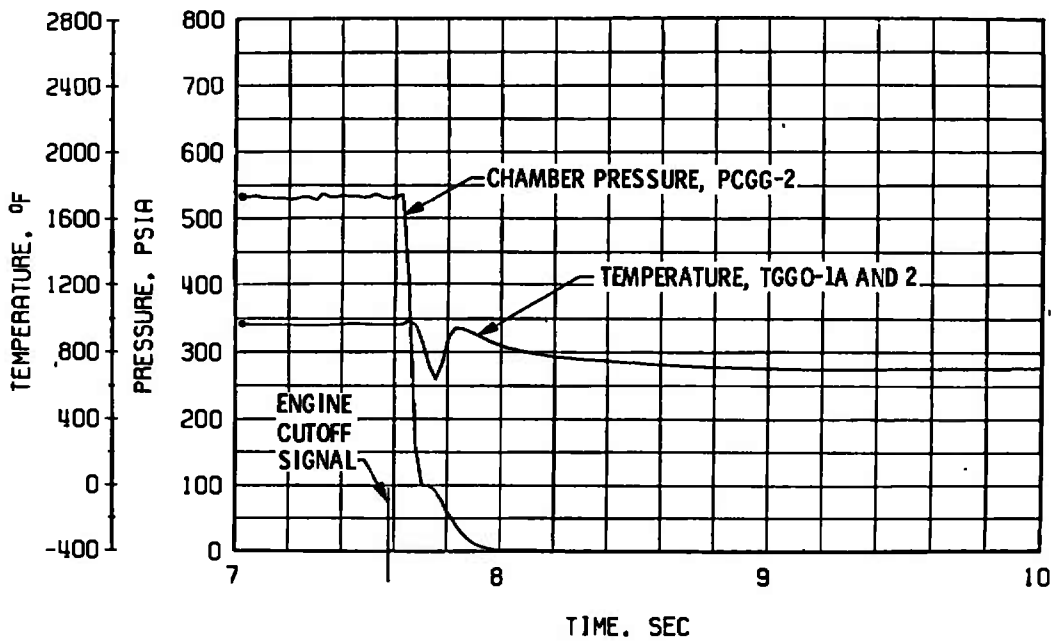

h. Gas Generator Chamber Pressure and Temperature, Shutdown

Fig. 46 Concluded

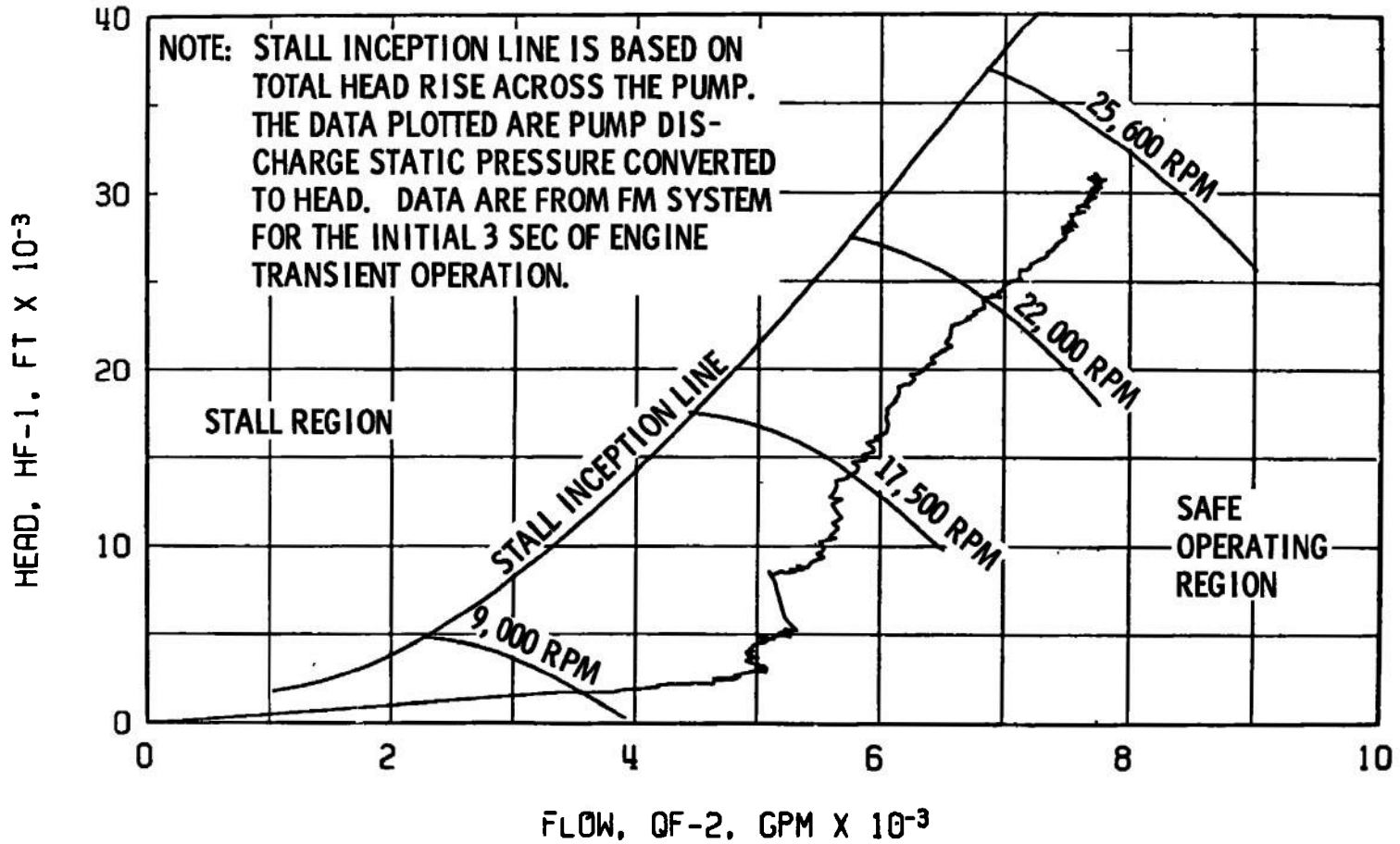

Fig. 47 Fuel Pump Start Transient Performance, Firing 11B

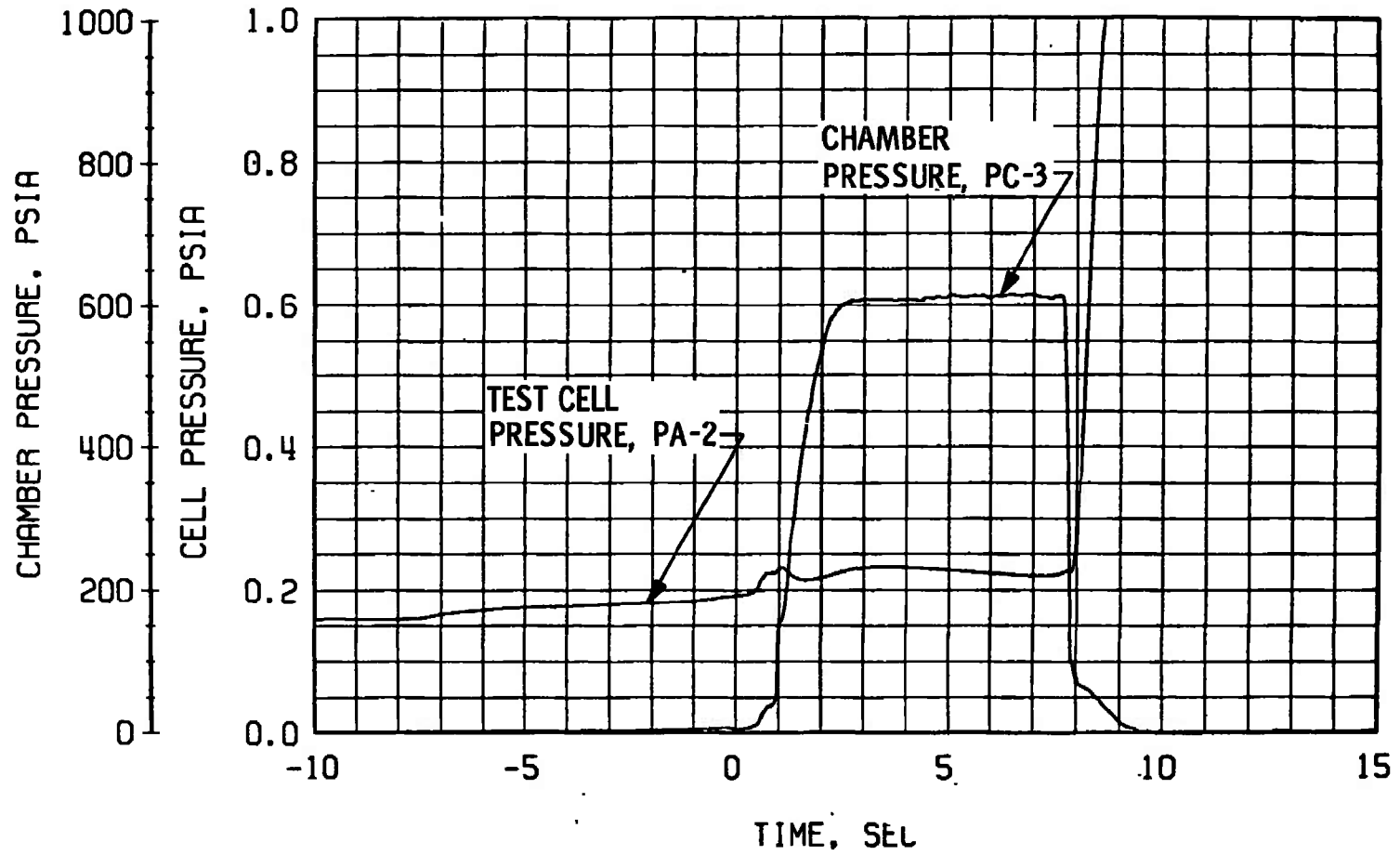
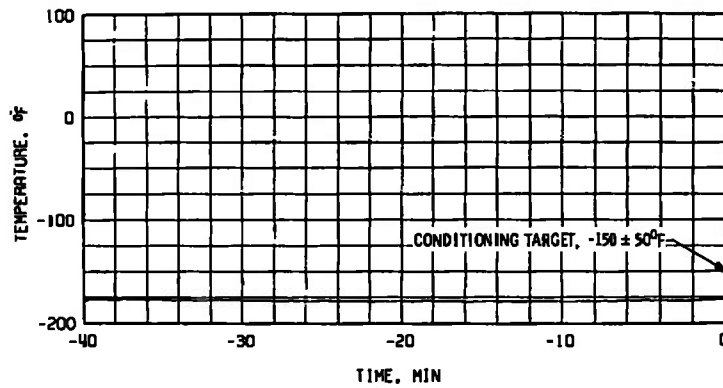
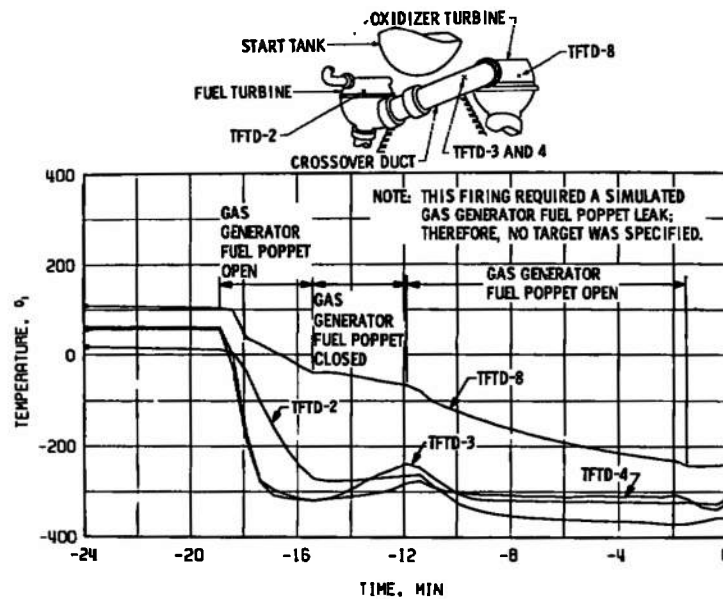

Fig. 48 Engine Ambient and Combustion Chamber Pressure, Firing 11B



a. Main Oxidizer Valve Second-Stage Actuator, TSOVC-1



b. Crossover Duct, TTFD

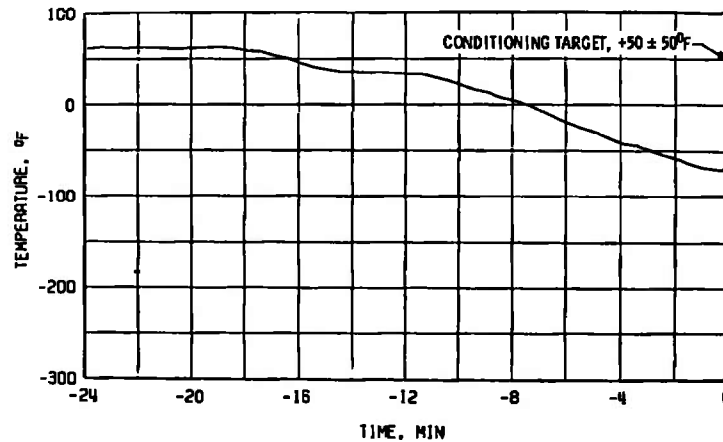

c. Thrust Chamber, TTC-1P

Fig. 49 Thermal Conditioning History of Engine Components, Firing 11C

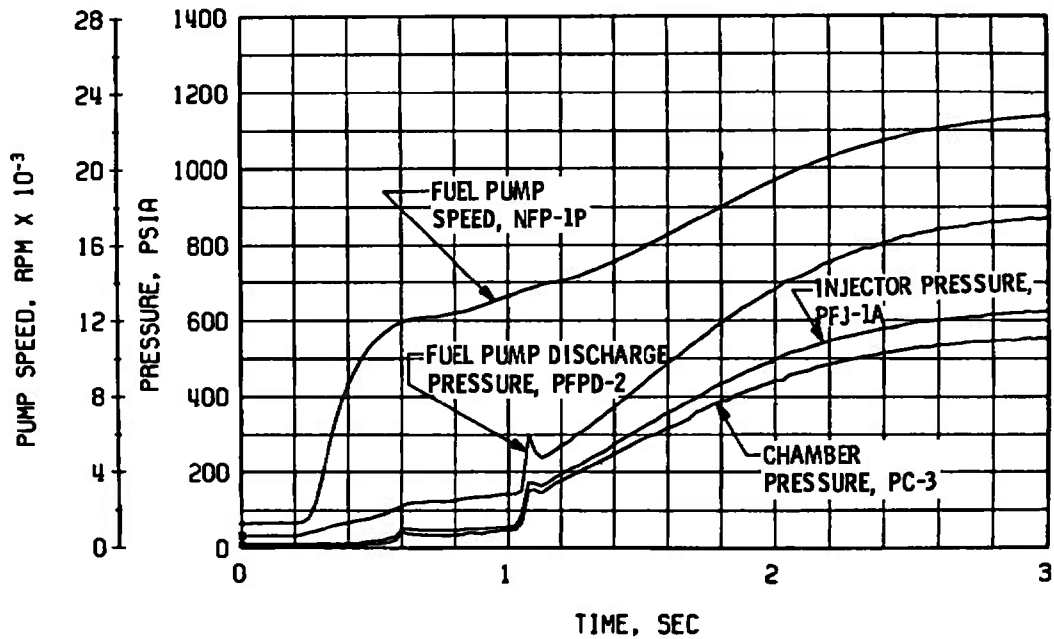

a. Thrust Chamber Fuel System, Start

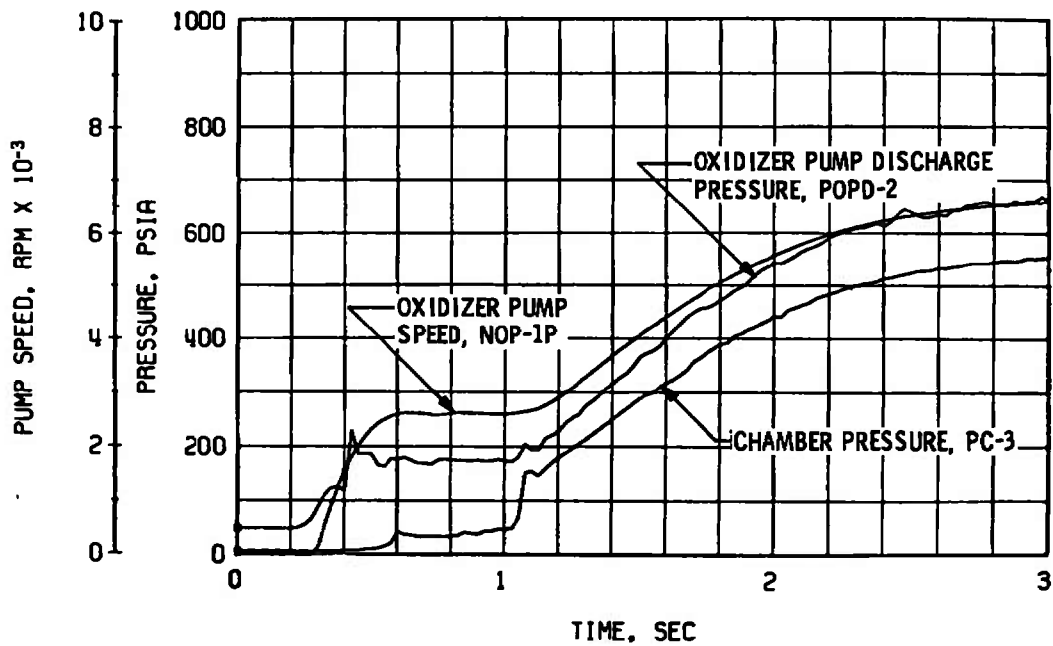

b. Thrust Chamber Oxidizer System, Start

Fig. 50 Engine Transient Operation, Firing 11C

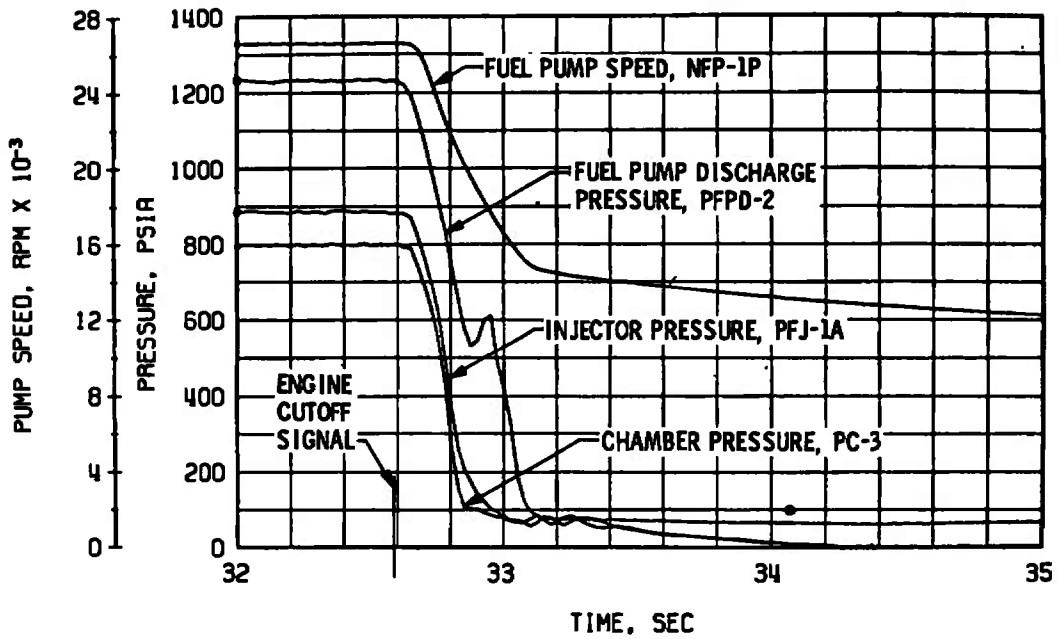

c. Thrust Chamber Fuel System, Shutdown

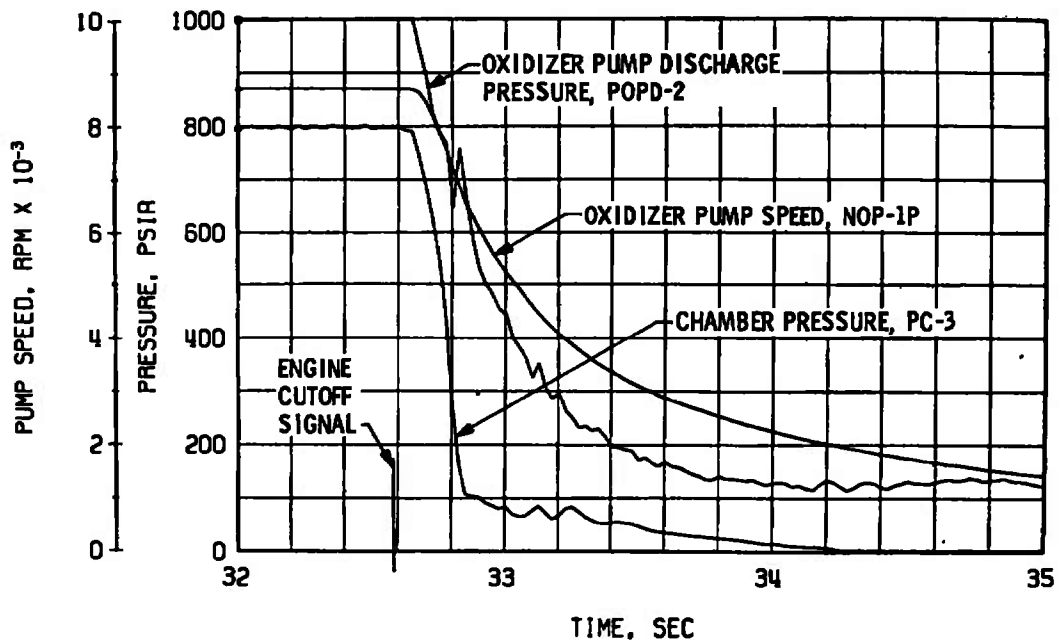

d. Thrust Chamber Oxidizer System, Shutdown

Fig. 50 Continued

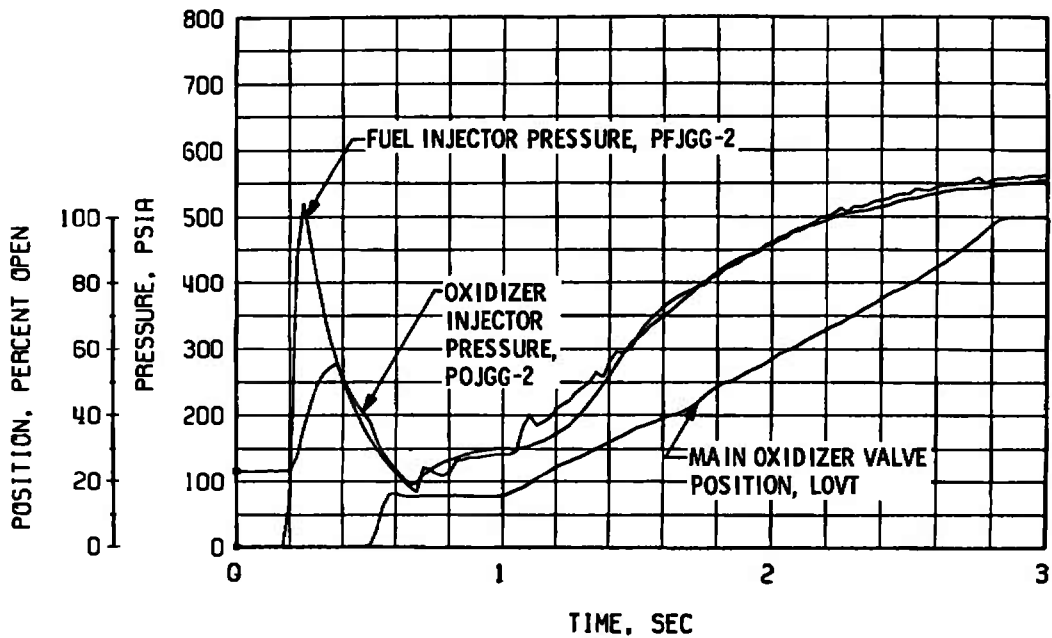

e. Gas Generator Injector Pressures and Main Oxidizer Valve Position, Start

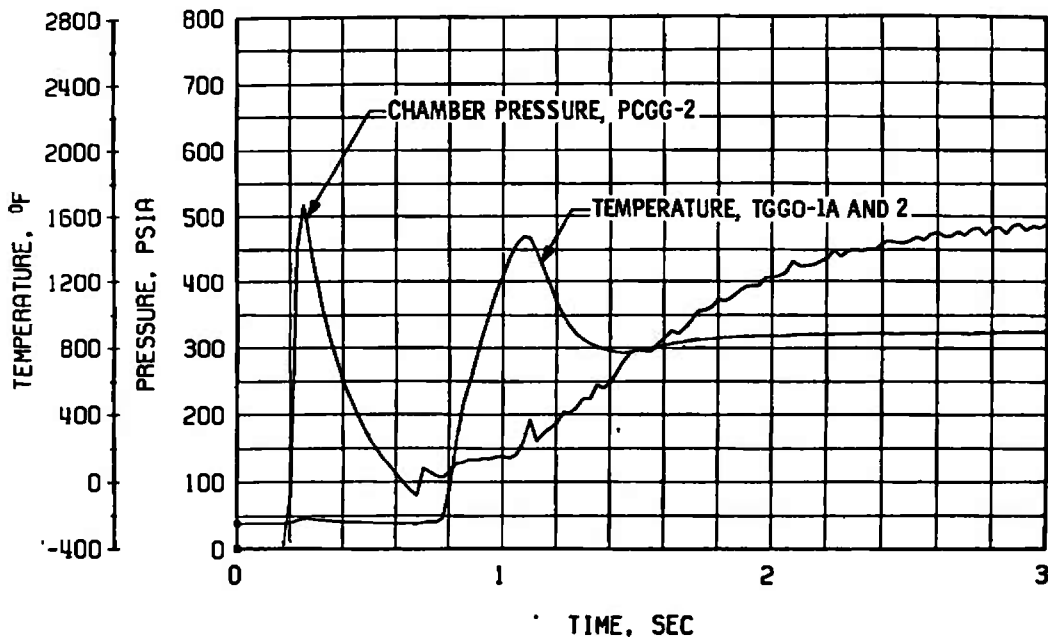

f. Gas Generator Chamber Pressure and Temperature, Start

Fig. 50 Continued

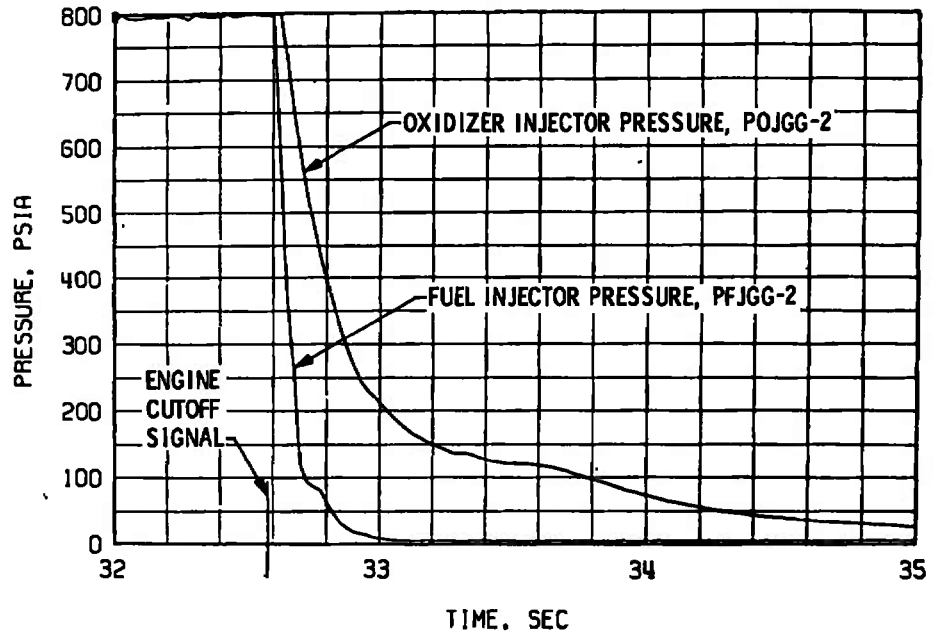

g. Gas Generator Injector Pressures, Shutdown

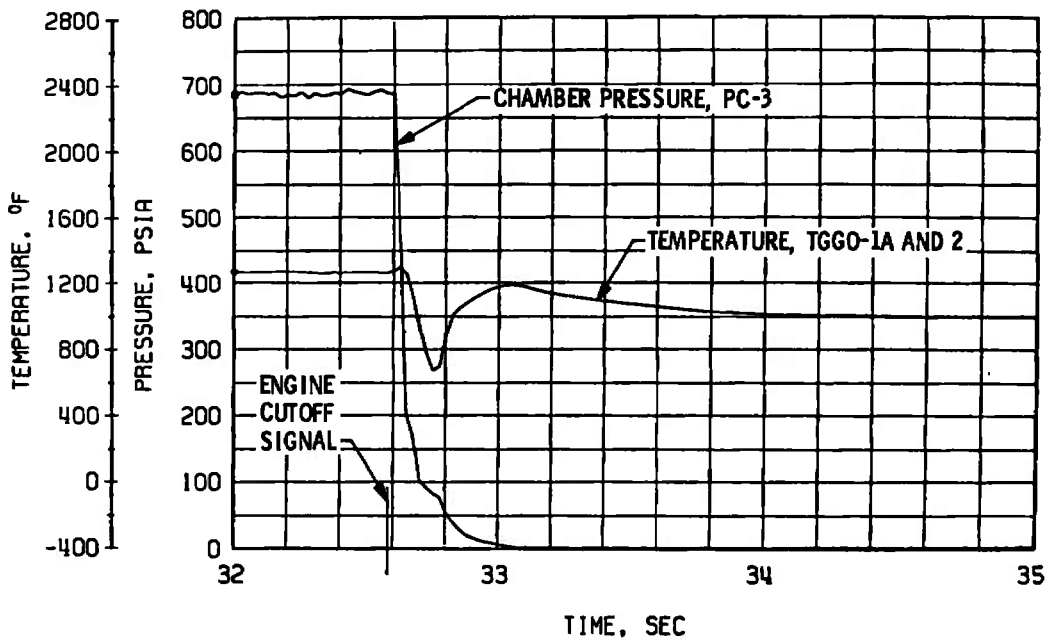

h. Gas Generator Chamber Pressure and Temperature, Shutdown

Fig. 50 Concluded

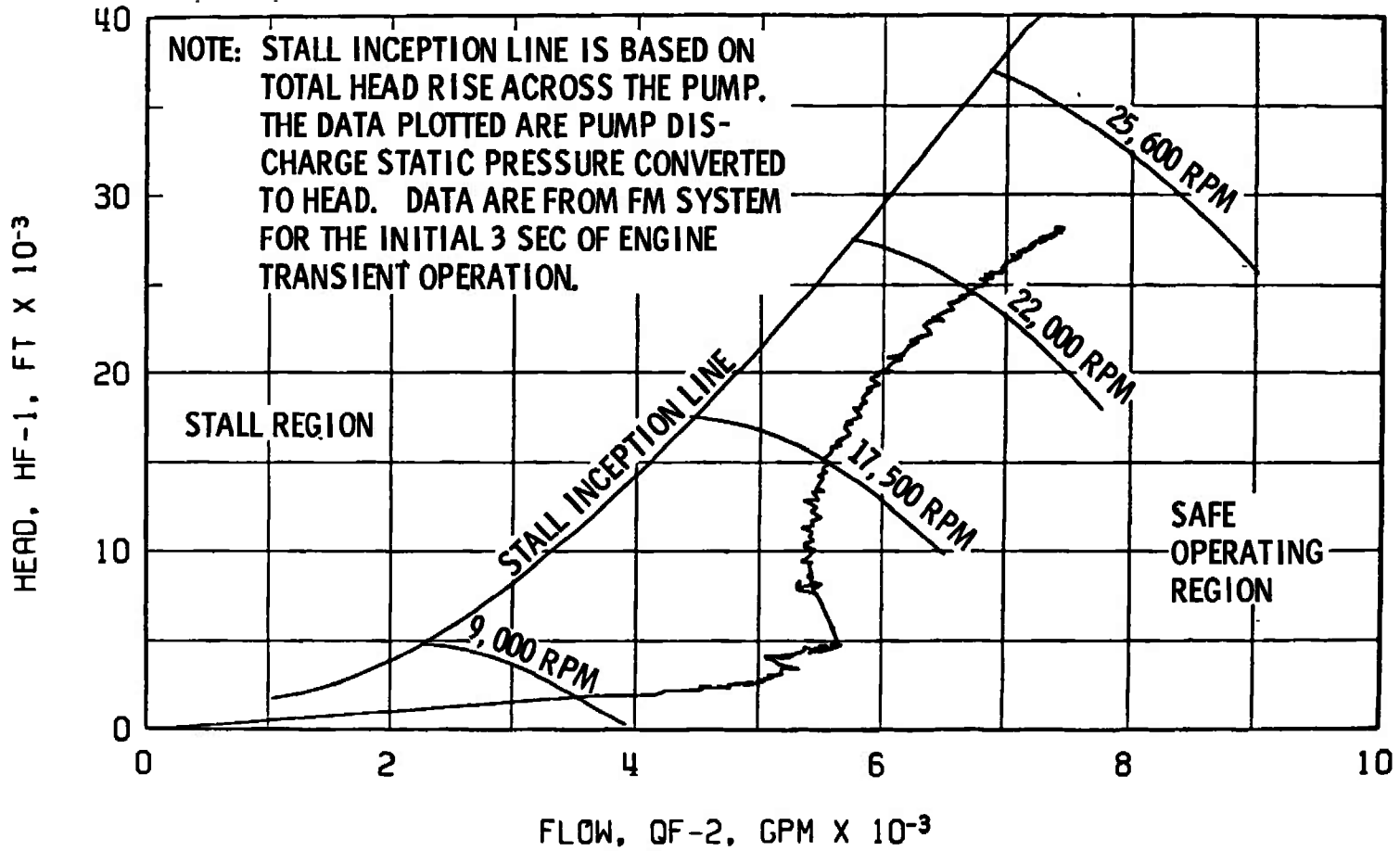

Fig. 51 Fuel Pump Start Transient Performance, Firing 11C

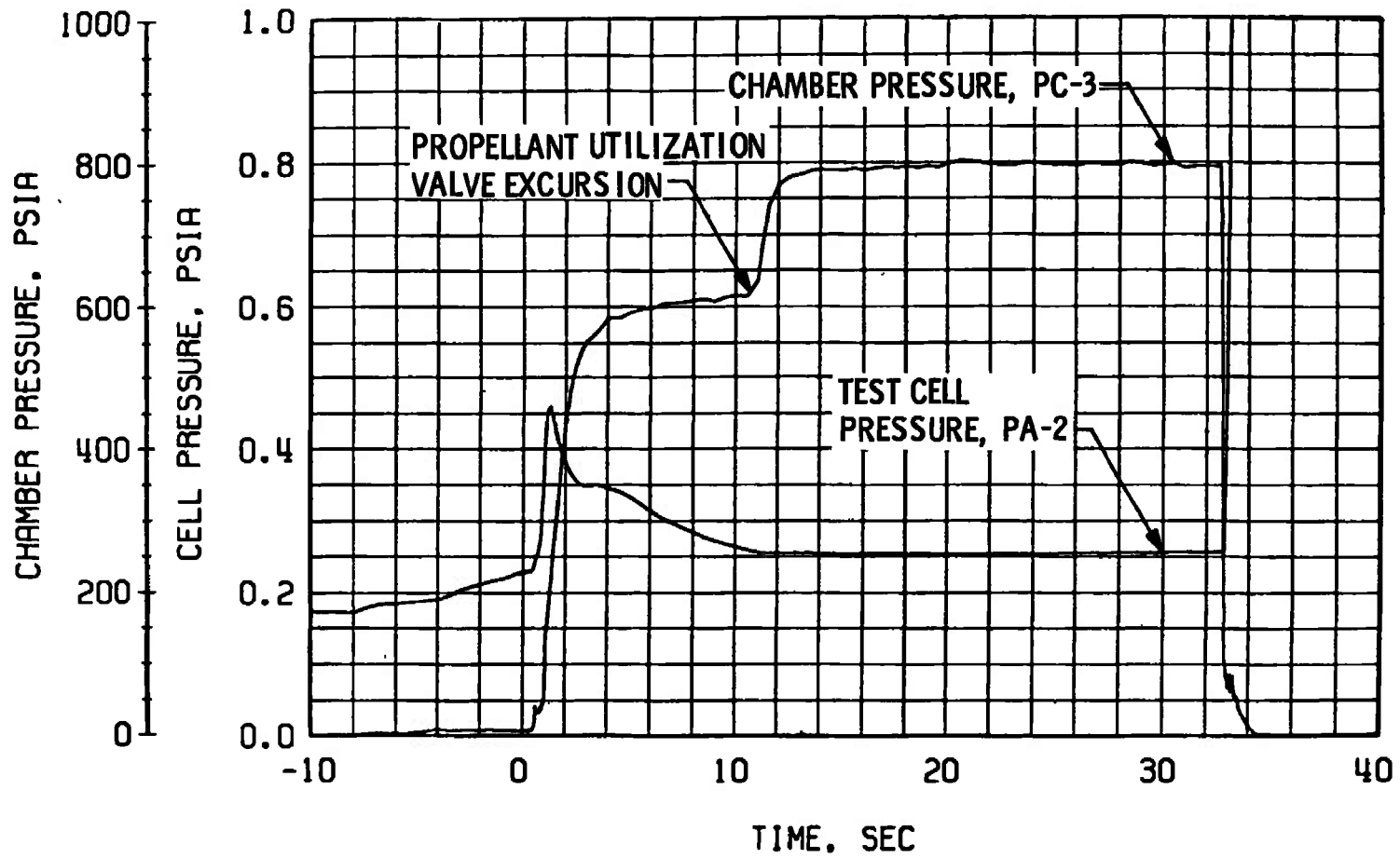
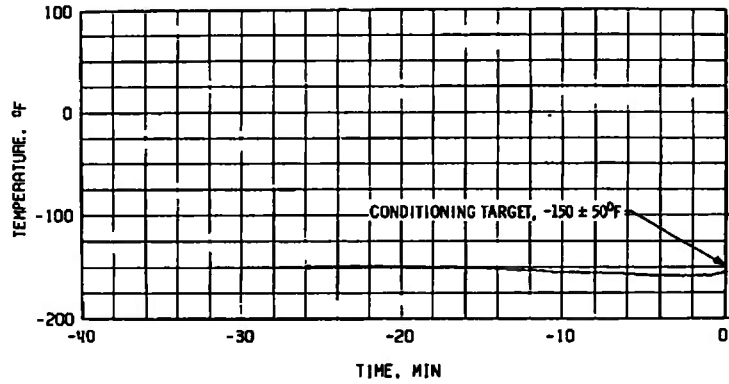
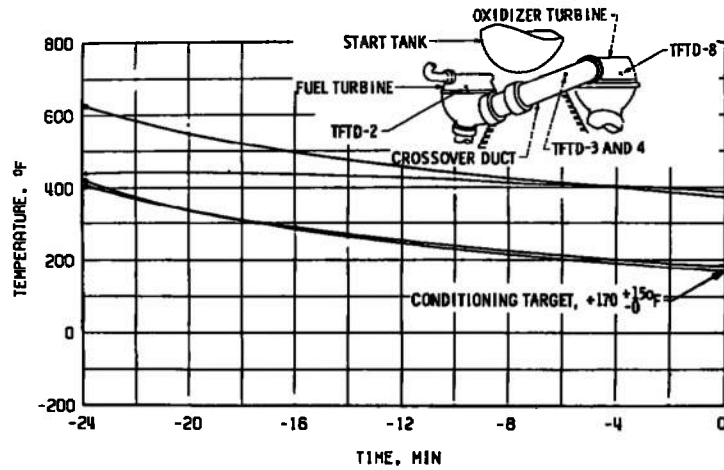

Fig. 52 Engine Ambient and Combustion Chamber Pressure, Firing 11C



a. Main Oxidizer Valve Second-Stage Actuator, TSOVC-1



b. Crossover Duct, TFTD

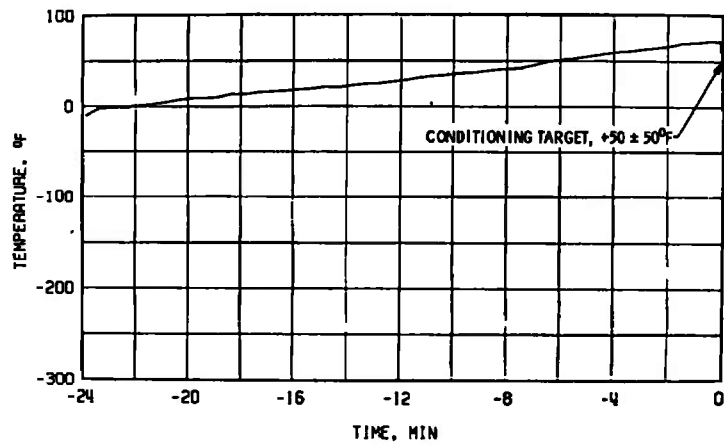

c. Thrust Chamber, TTC-1P

Fig. 53 Thermal Conditioning History of Engine Components, Firing 11D

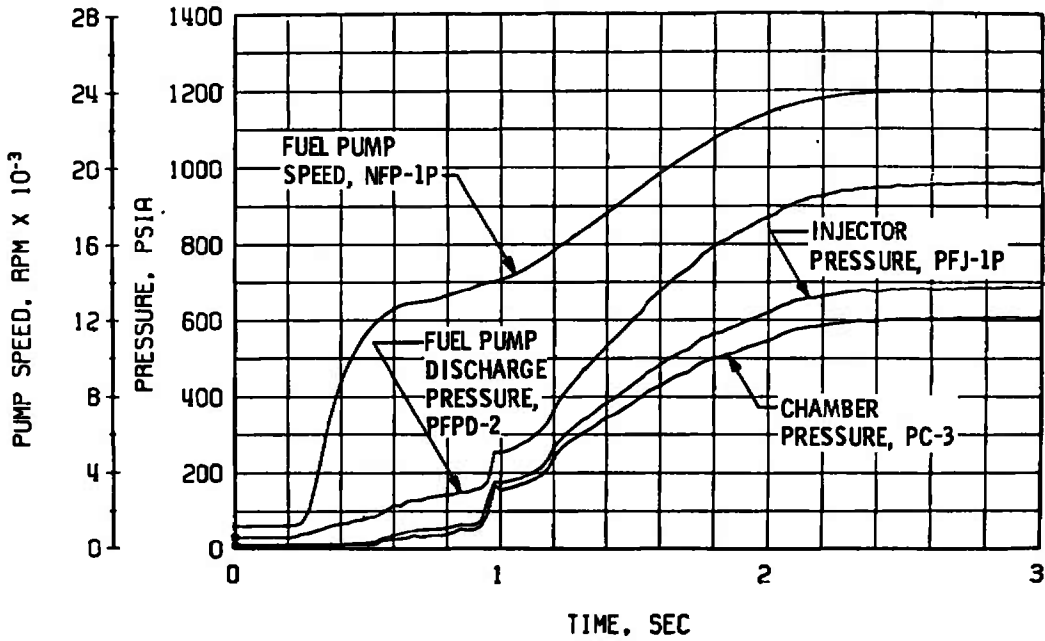

a. Thrust Chamber Fuel System, Start

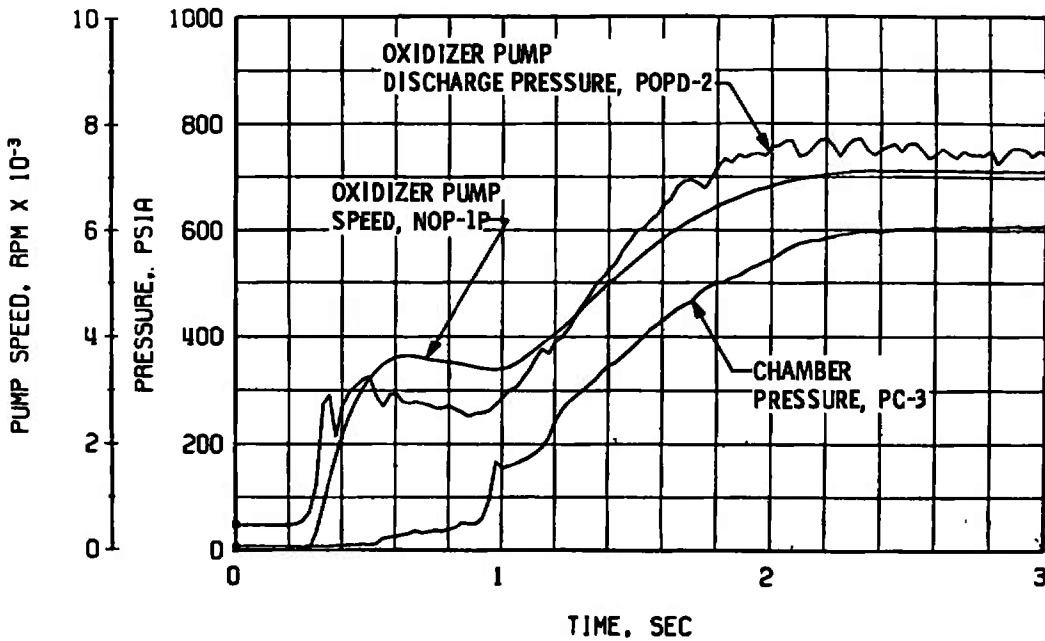

b. Thrust Chamber Oxidizer System, Start

Fig. 54 Engine Transient Operation, Firing 11D

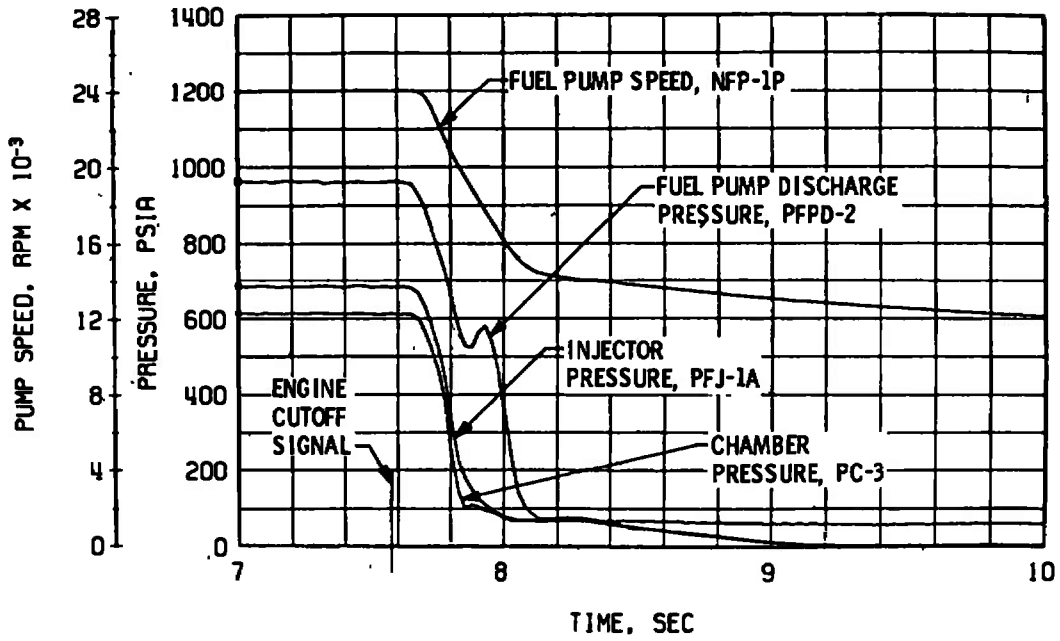

c. Thrust Chamber Fuel System, Shutdown

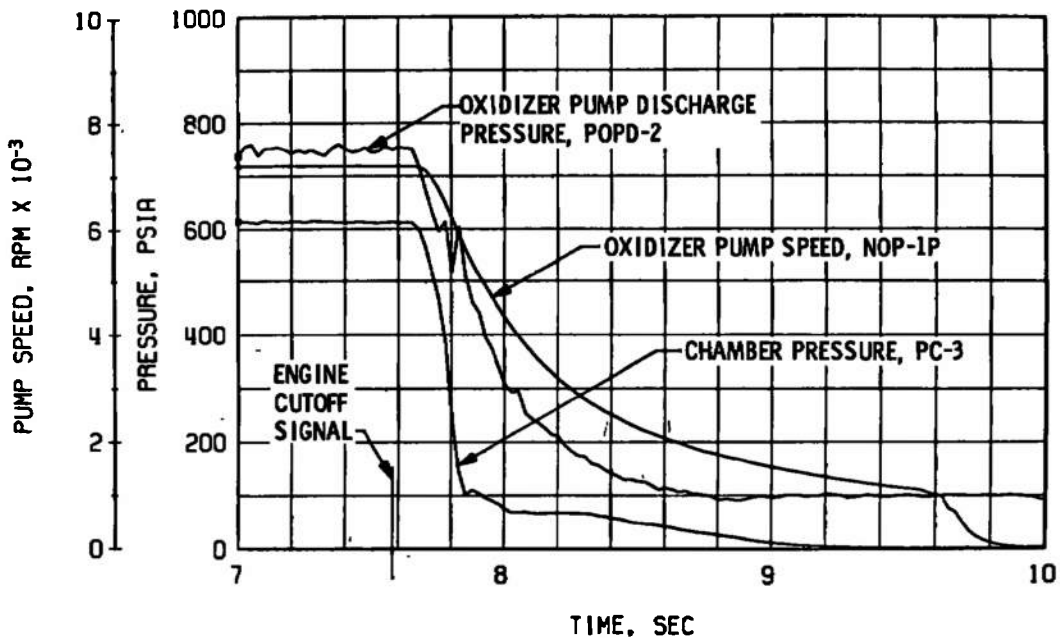

d. Thrust Chamber Oxidizer System, Shutdown

Fig. 54 Continued

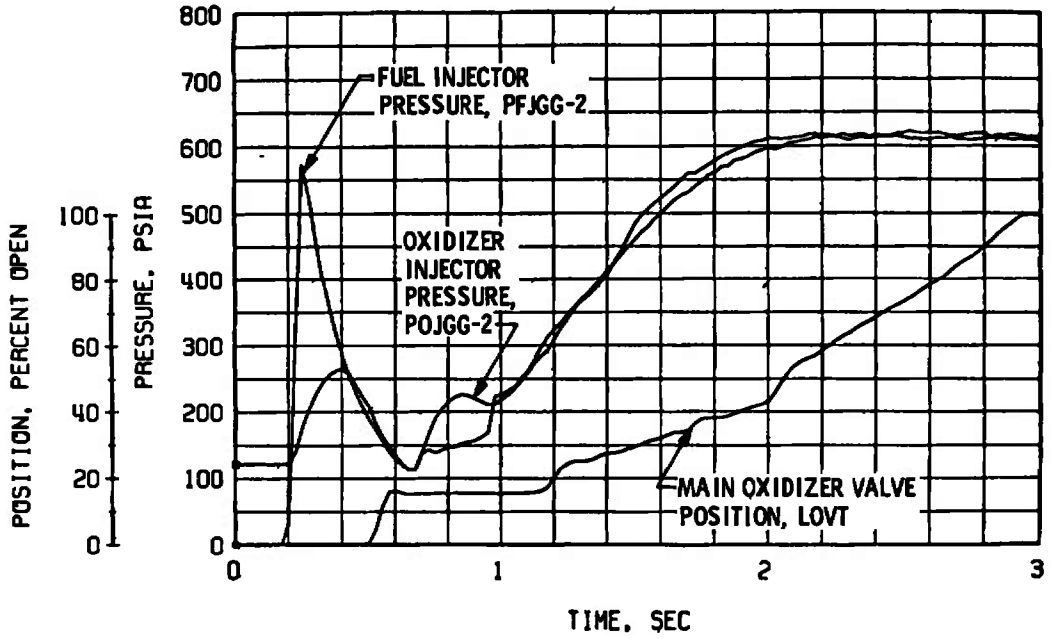

e. Gas Generator Injector Pressures and Main Oxidizer Valve Position, Start

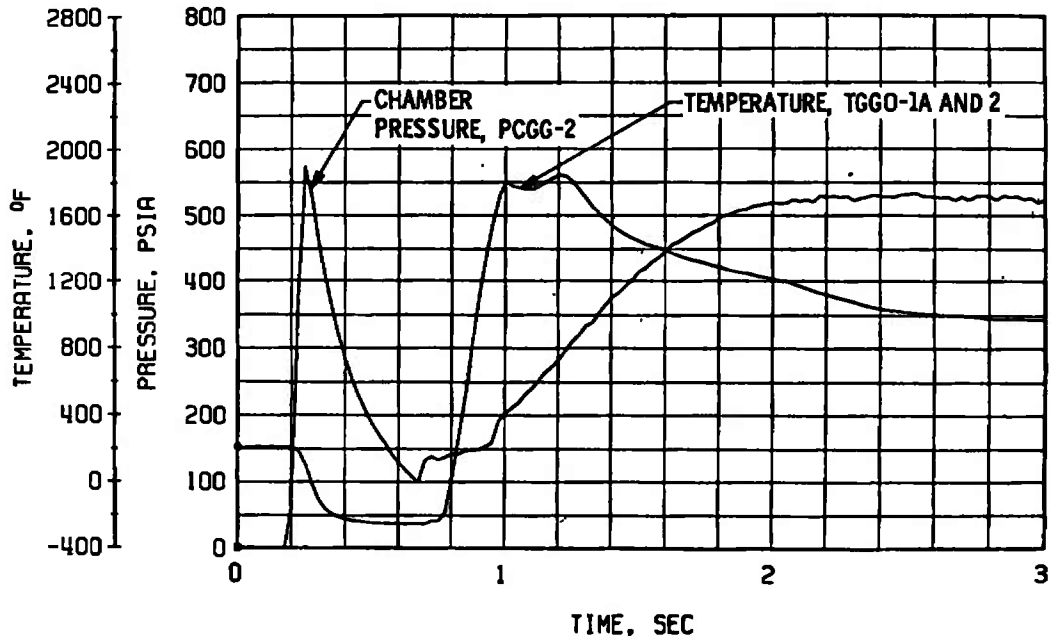

f. Gas Generator Chamber Pressure and Temperature, Start

Fig. 54 Continued

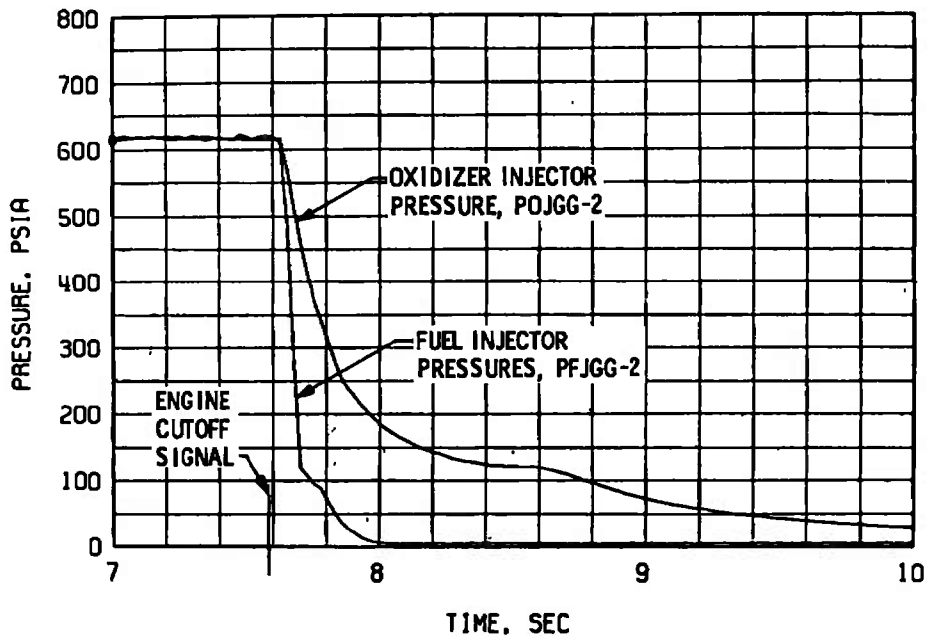

g. Gas Generator Injector Pressures, Shutdown

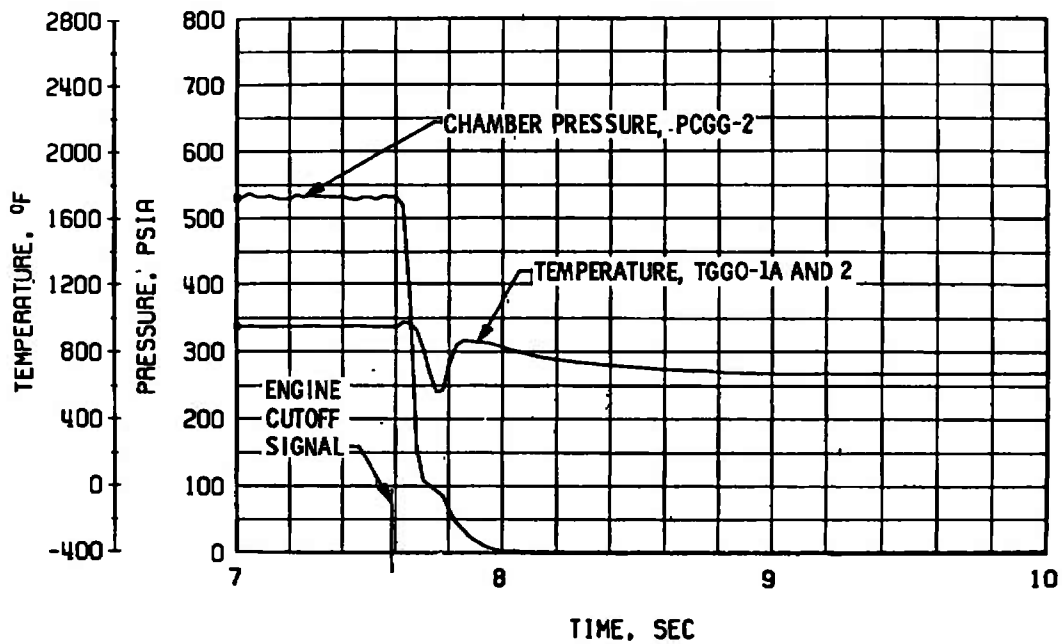

h. Gas Generator Chamber Pressure and Temperature, Shutdown

Fig. 54 Concluded

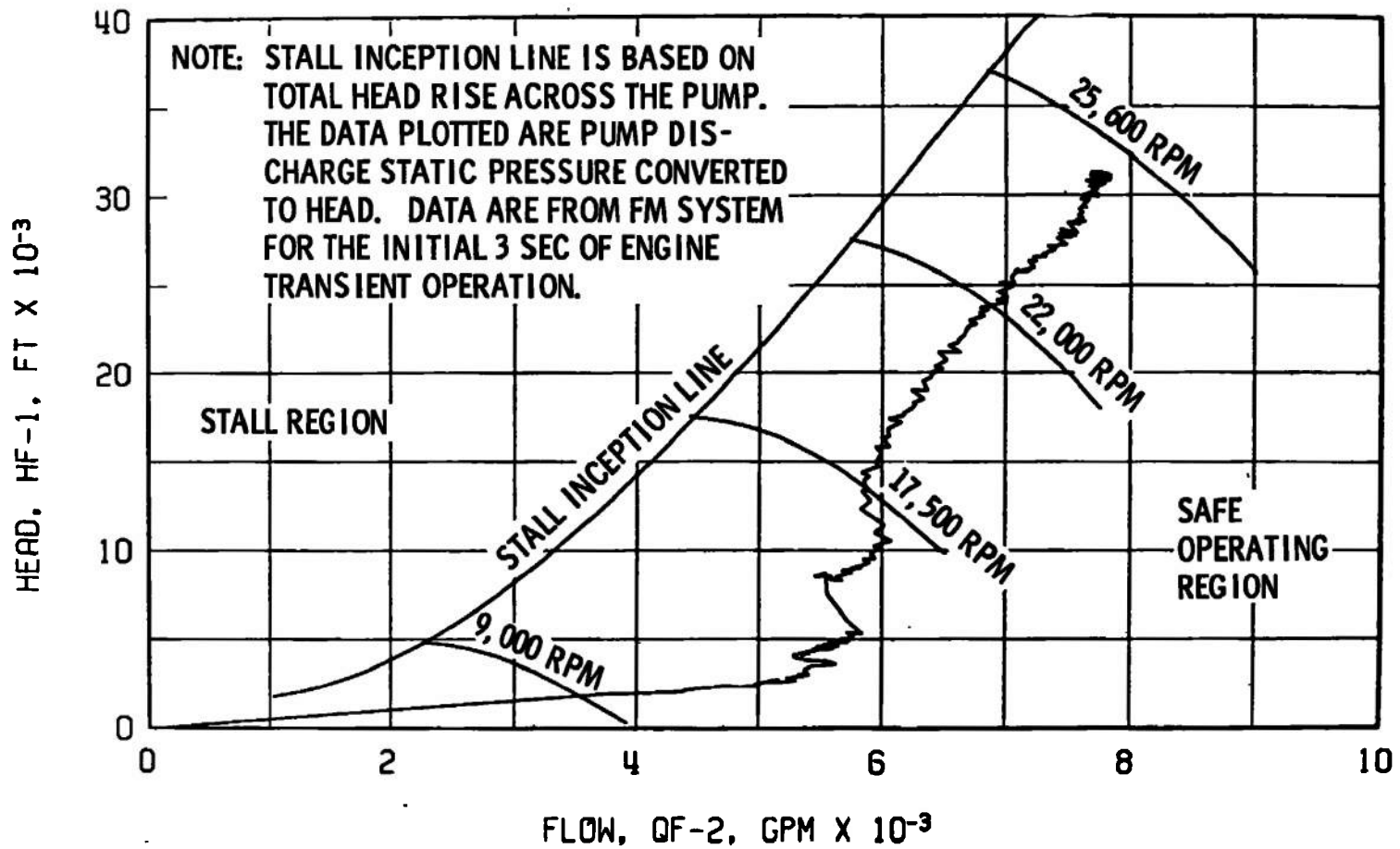

Fig. 55 Fuel Pump Start Transient Performance, Firing 11D

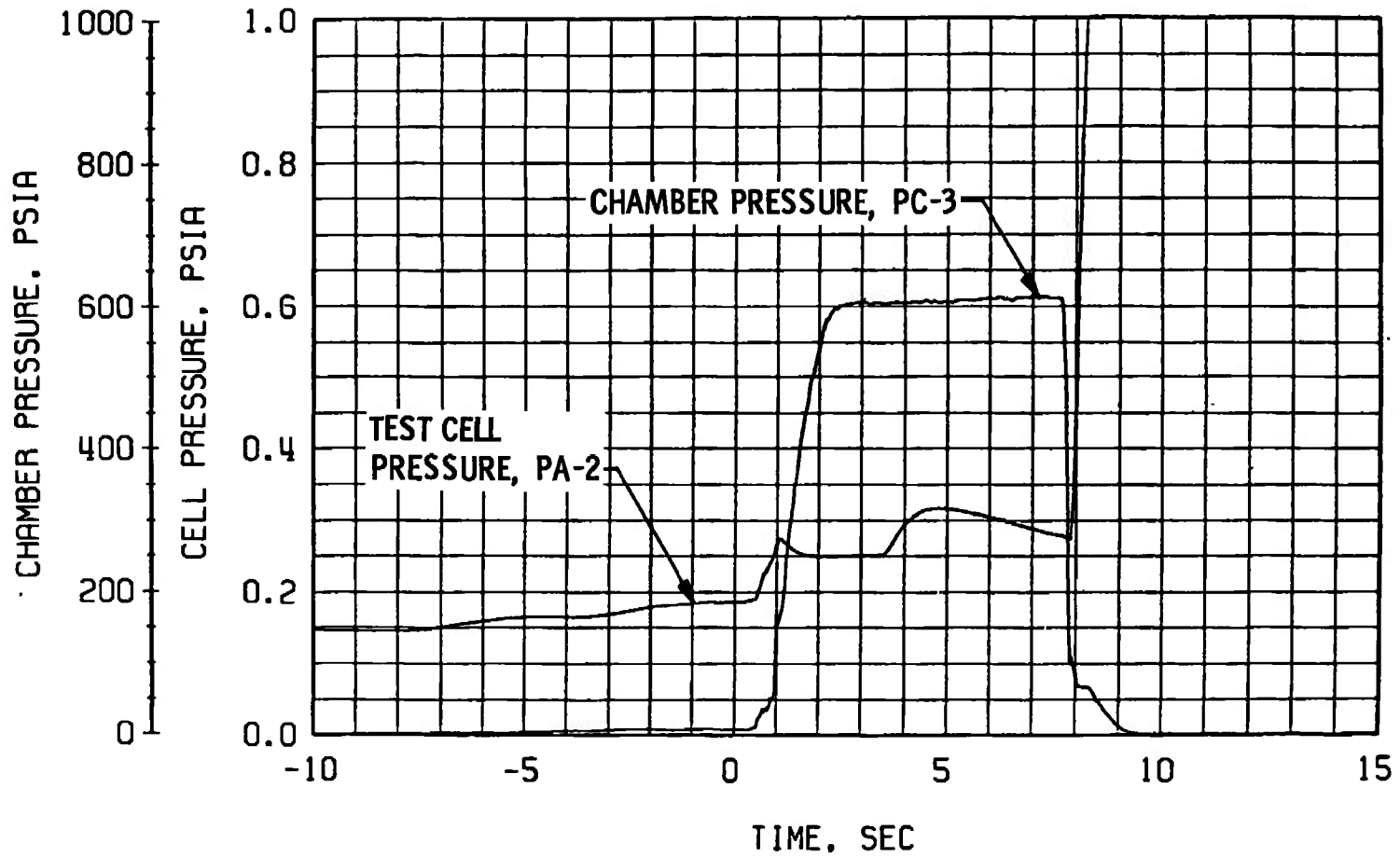
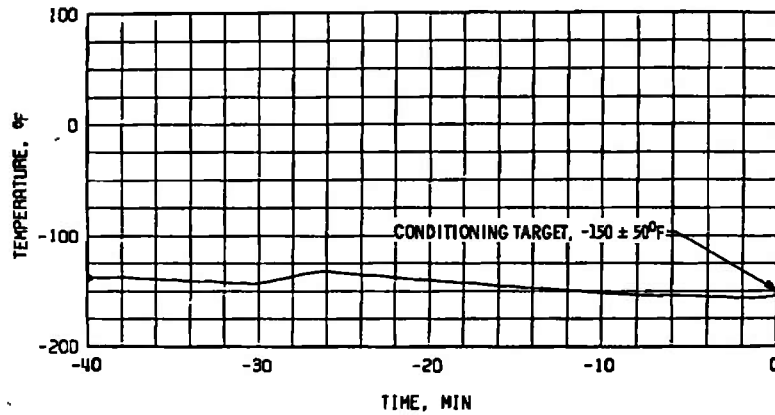
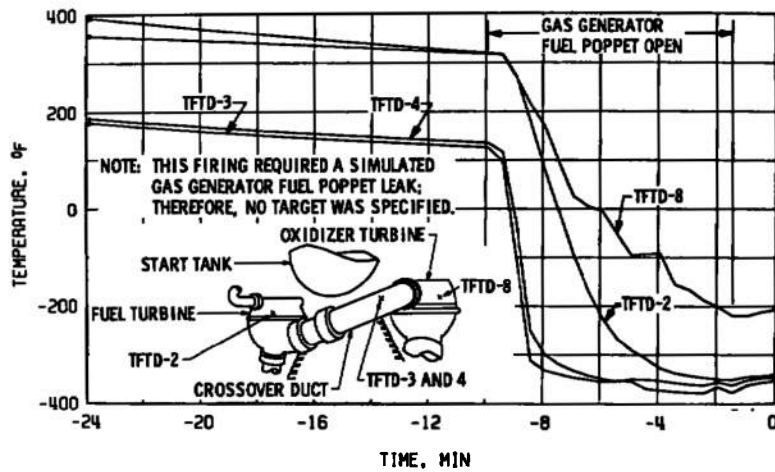

Fig. 56 Engine Ambient and Combustion Chamber Pressure, Firing 11D



a. Main Oxidizer Valve Second-Stage Actuator, TSOVC-1



b. Crossover Duct, TFTD

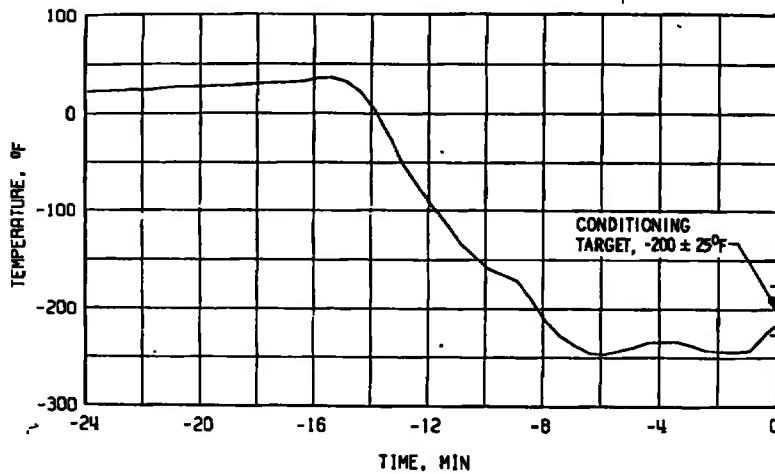

c. Thrust Chamber, TTC-1P

Fig. 57 Thermal Conditioning History of Engine Components, Firing 11E

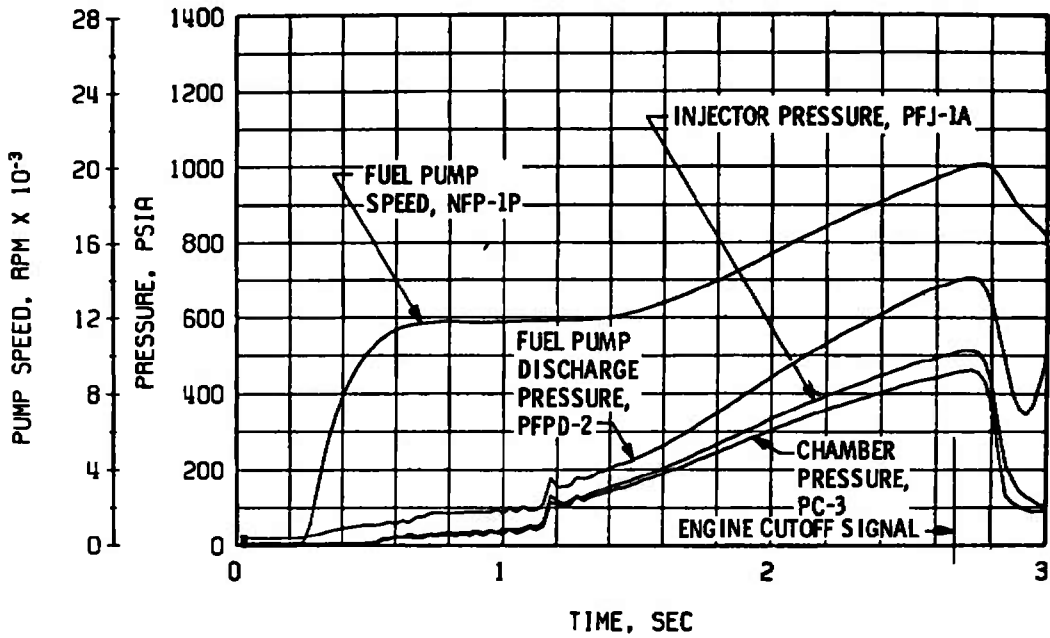

a. Thrust Chamber Fuel System, Start and Shutdown

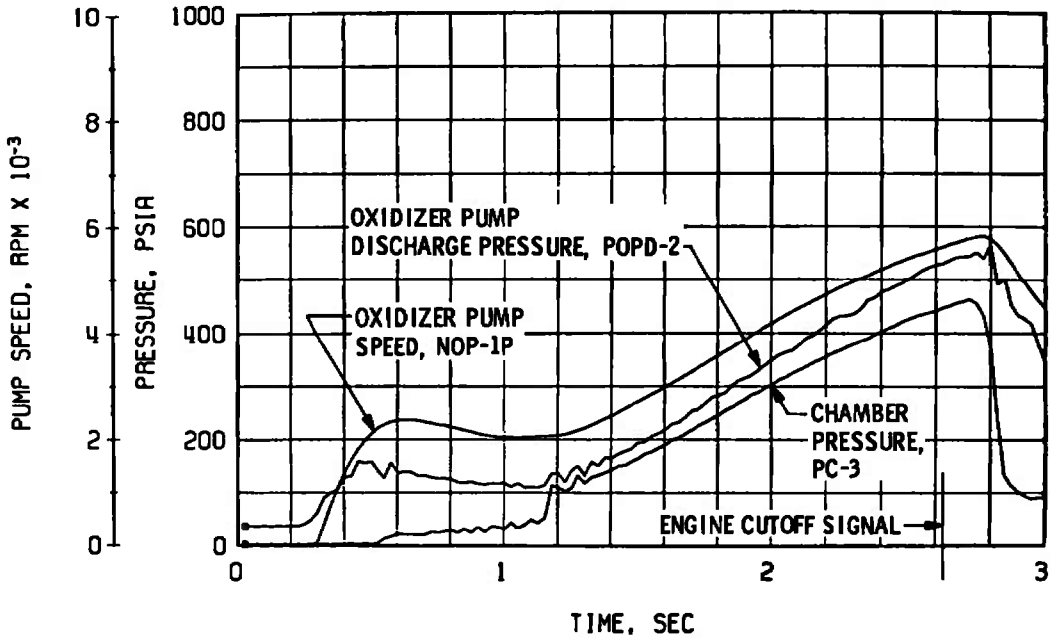

b. Thrust Chamber Oxidizer System, Start and Shutdown

Fig. 58 Engine Transient Operation, Firing 11E

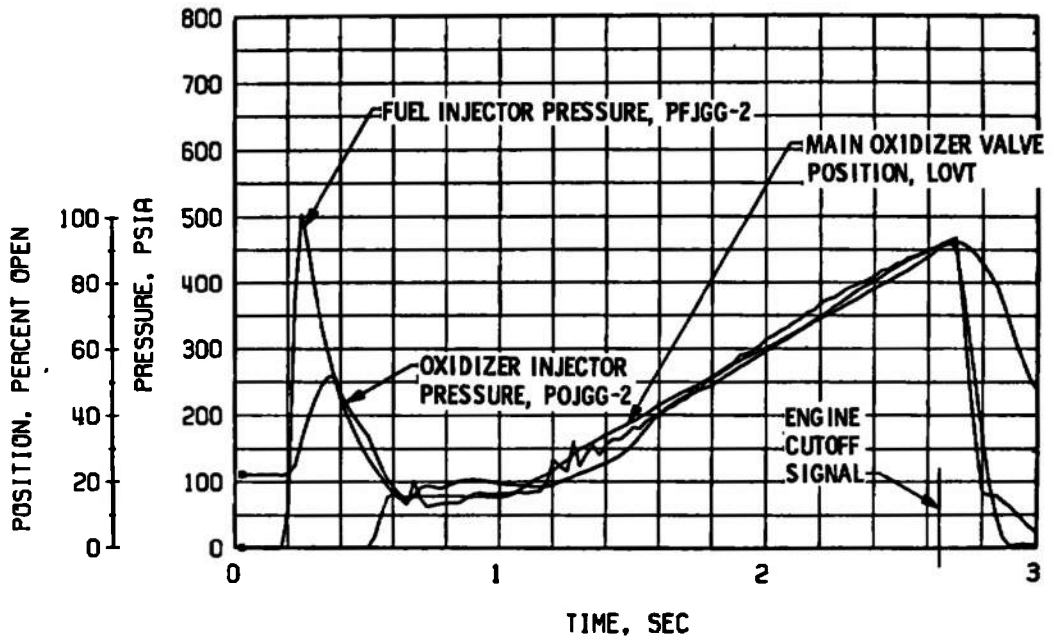

c. Gas Generator Injector Pressures and Main Oxidizer Valve Position, Start and Shutdown

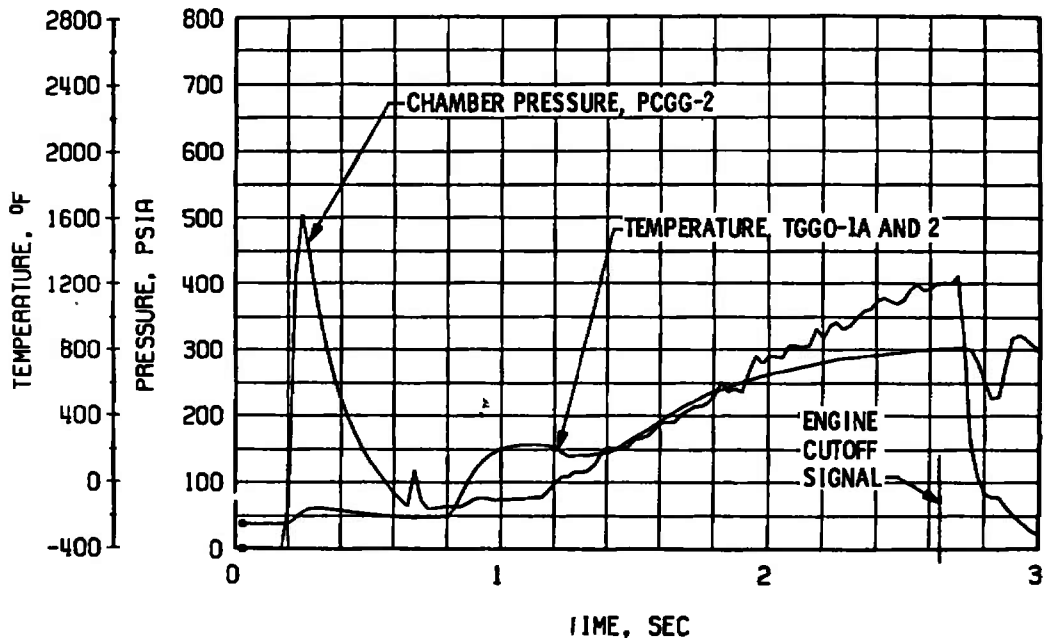

d. Gas Generator Chamber Pressure and Temperature, Start and Shutdown

Fig. 58 Concluded

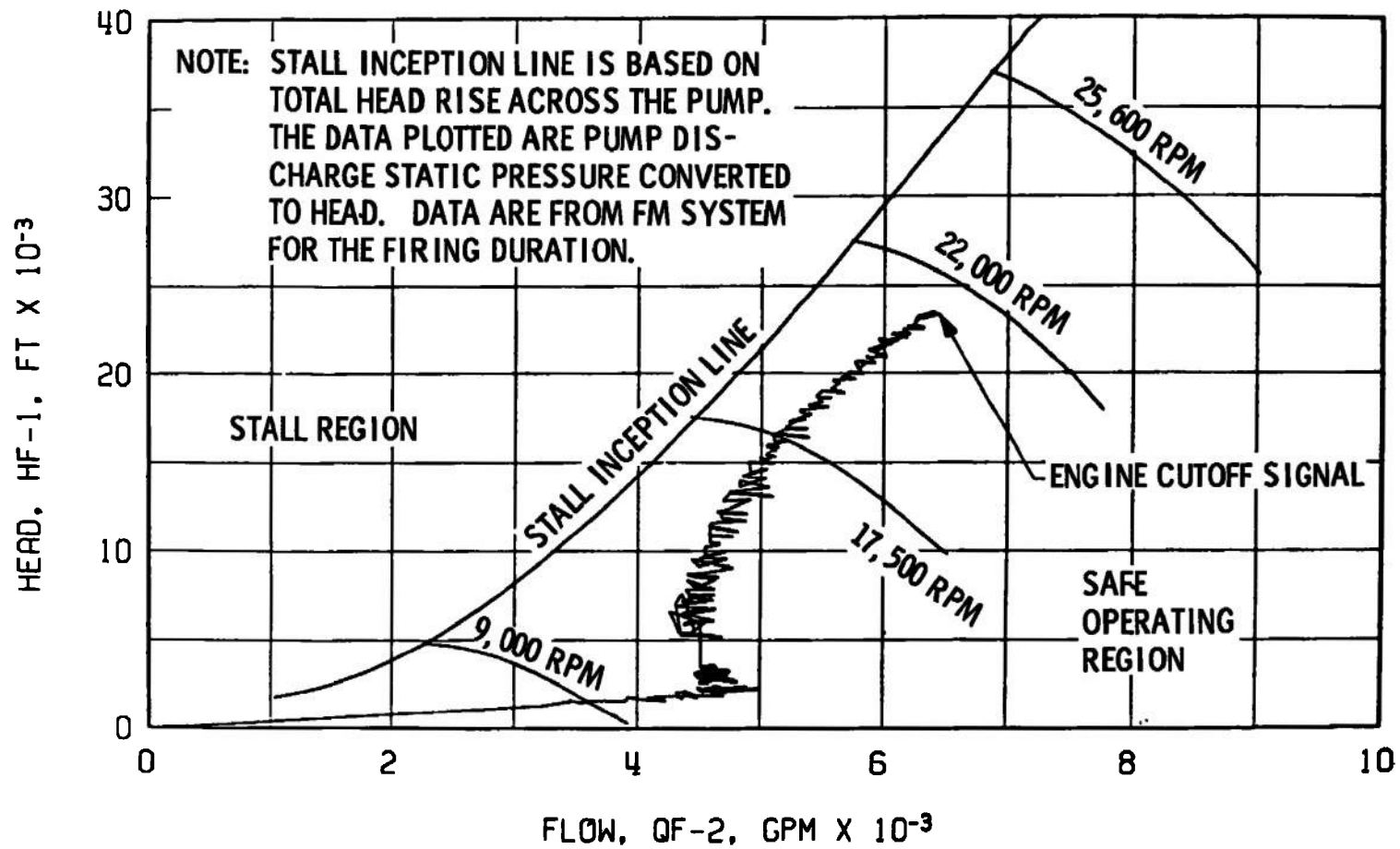

Fig. 59 Fuel Pump Start Transient Performance, Firing 11E

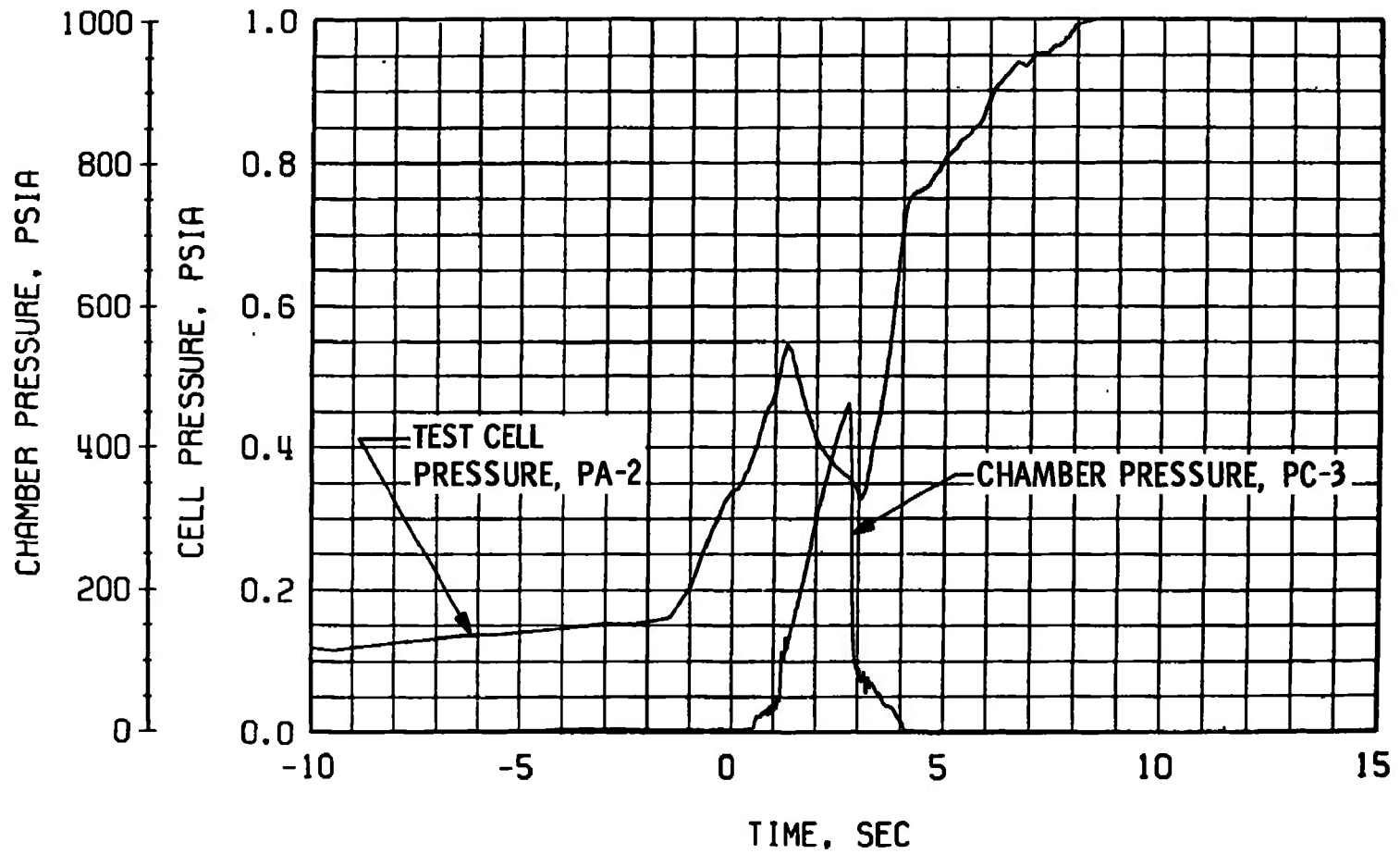
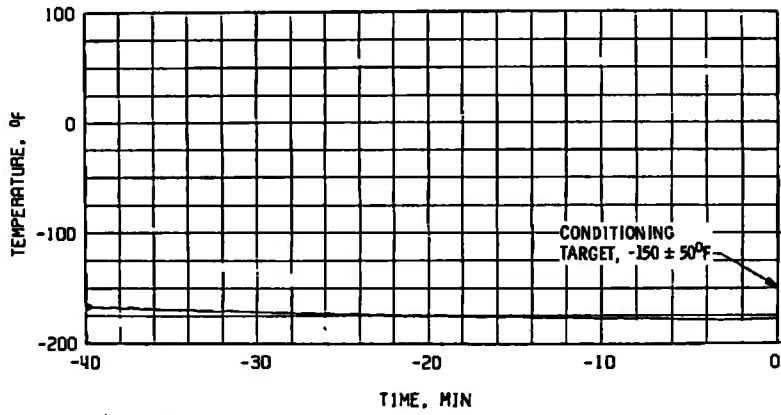
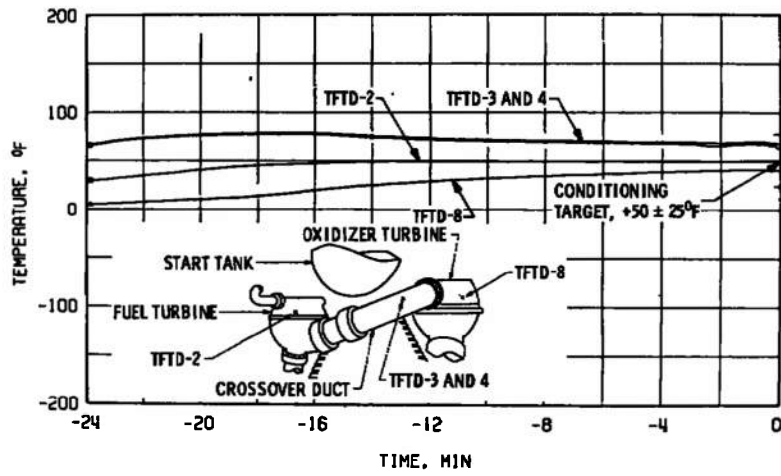

Fig. 60 Engine Ambient and Combustion Chamber Pressure, Firing 11E



a. Main Oxidizer Valve Second-Stage Actuator, TSOVC-1



b. Crossover Duct, TFTD

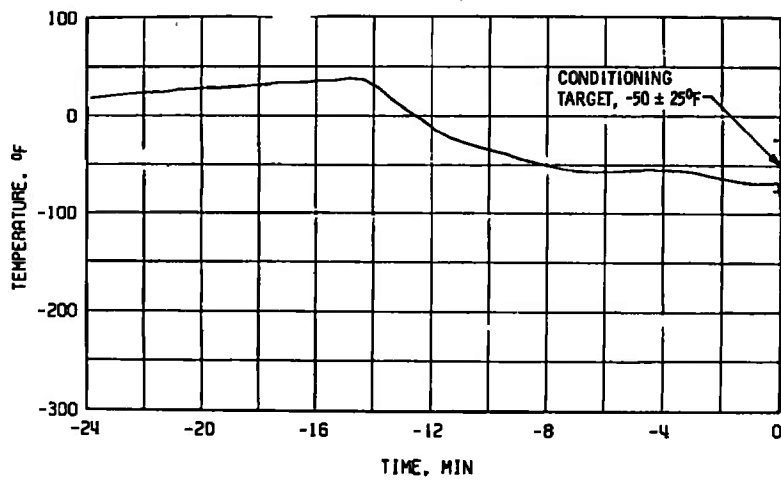

c. Thrust Chamber, TTC-1P

Fig. 61 Thermal Conditioning History of Engine Components, Firing 11F

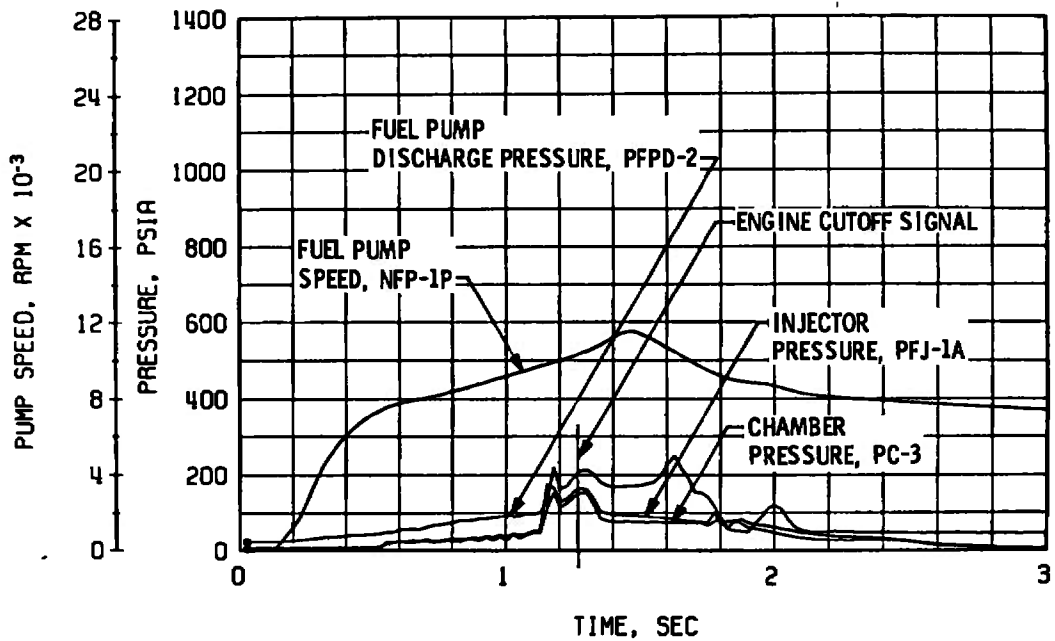

a. Thrust Chamber Fuel System, Start and Shutdown

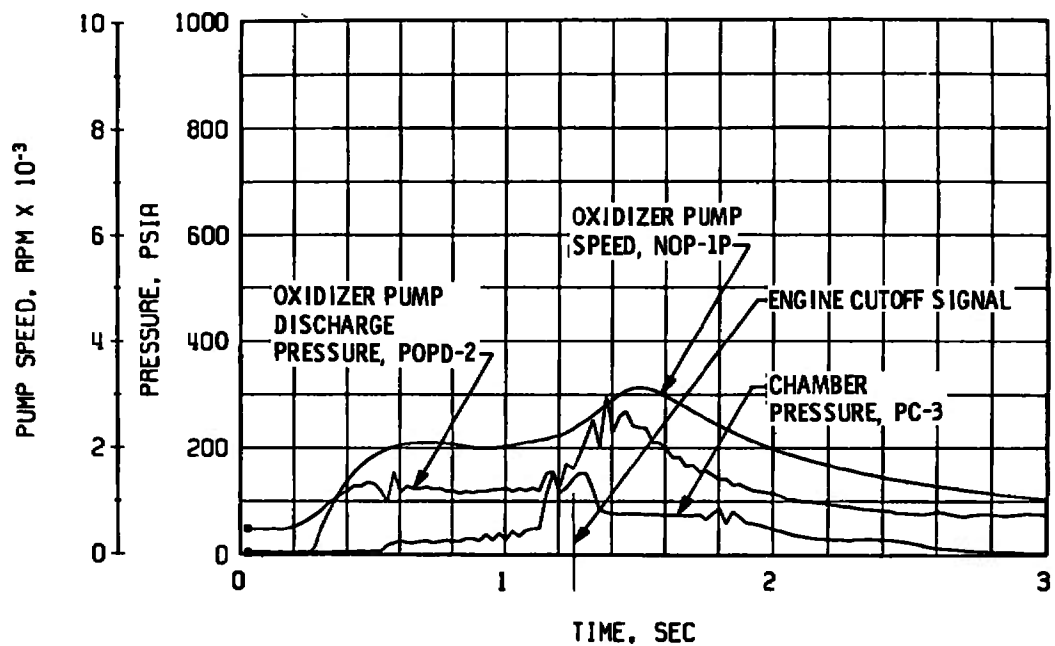

b. Thrust Chamber Oxidizer System, Start and Shutdown

Fig. 62 Engine Transient Operation, Firing 11F

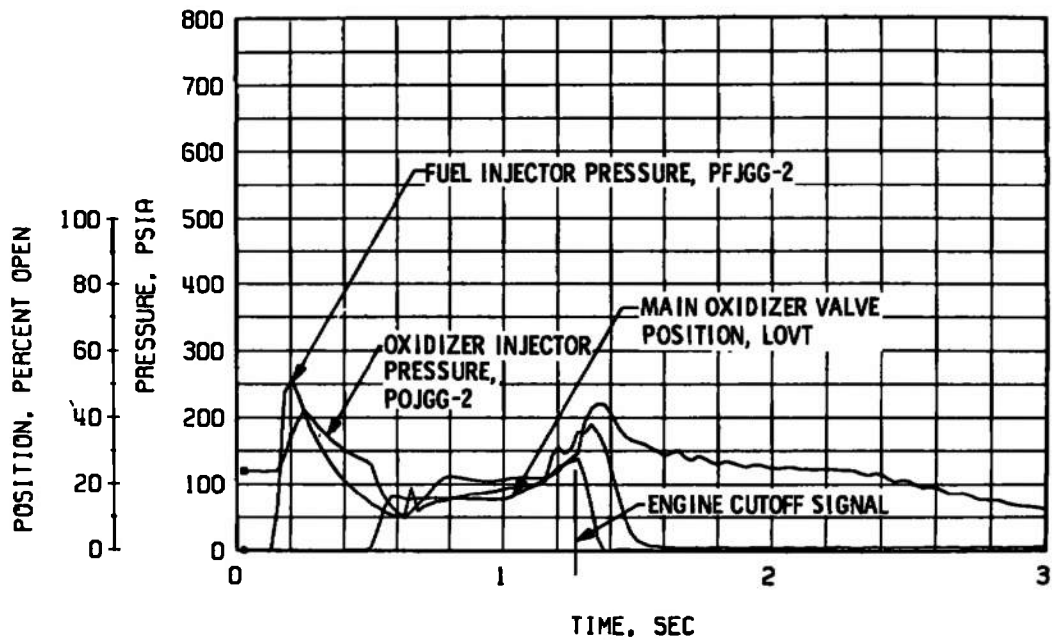

c. Gas Generator Injector Pressures and Main Oxidizer Valve Position, Start and Shutdown

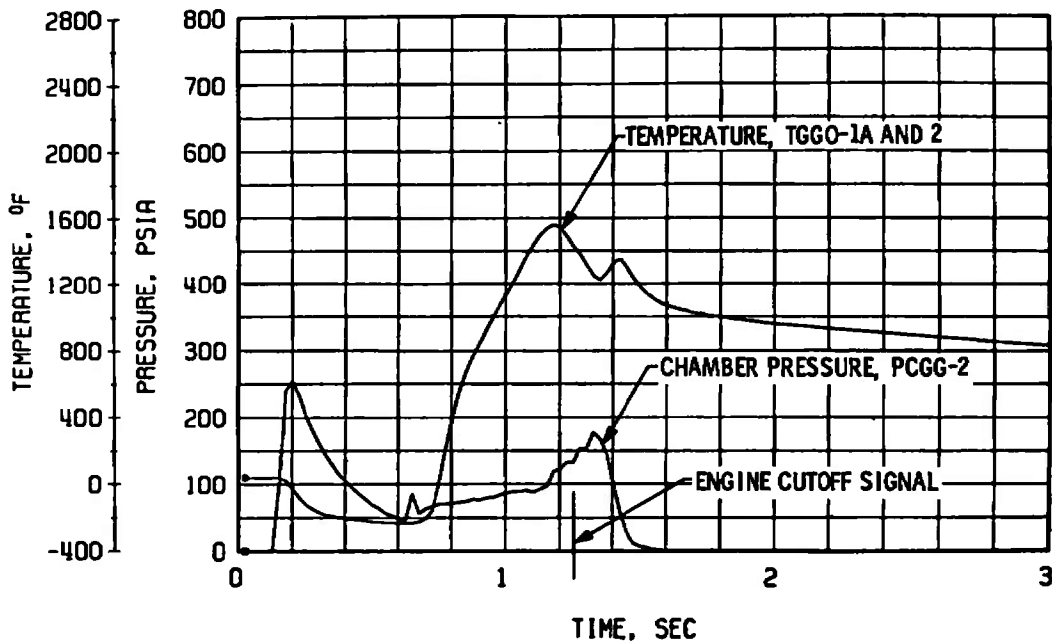

d. Gas Generator Chamber Pressure and Temperature, Start and Shutdown

Fig. 62 Concluded

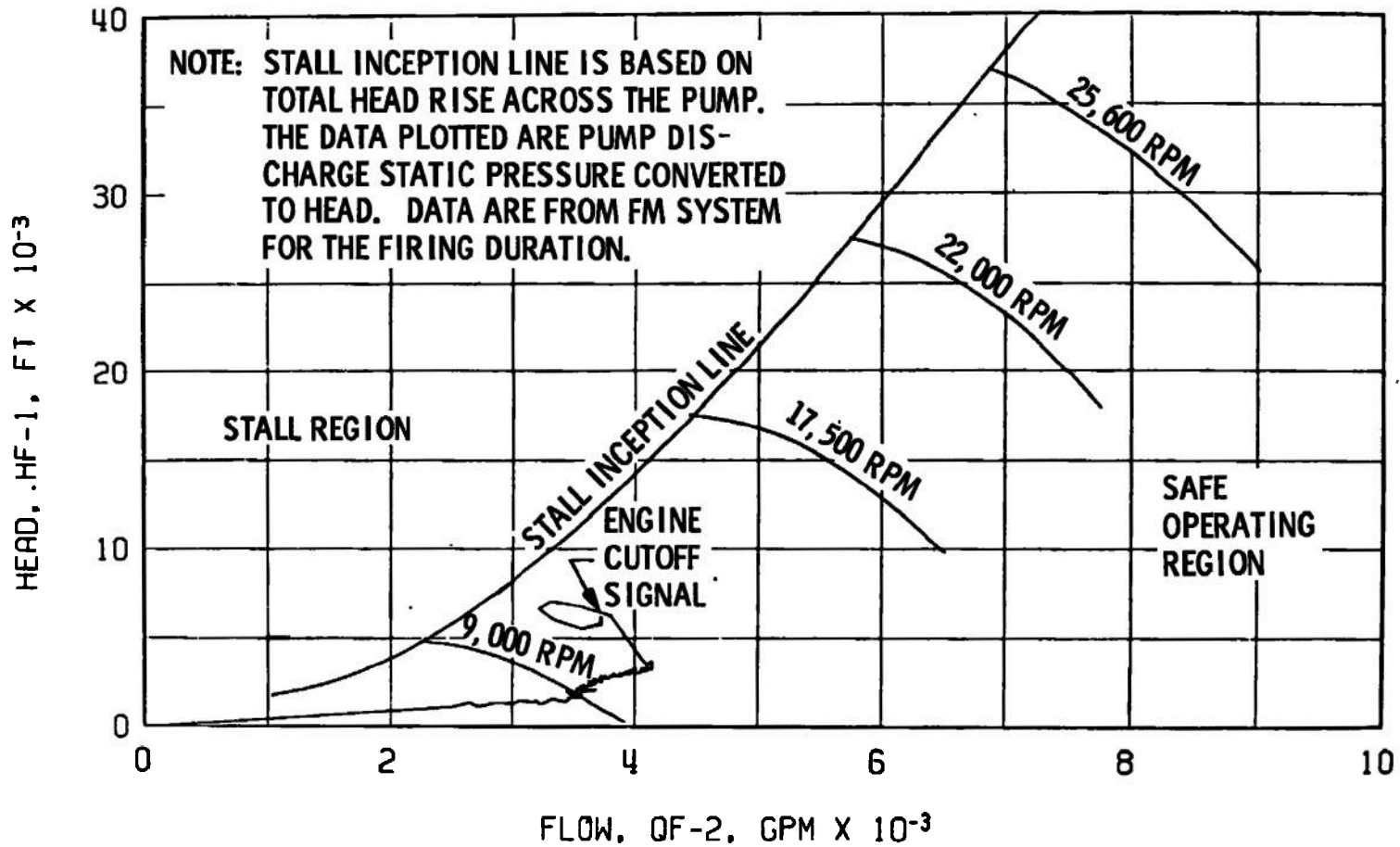

Fig. 63 Fuel Pump Start Transient Performance, Firing 11F

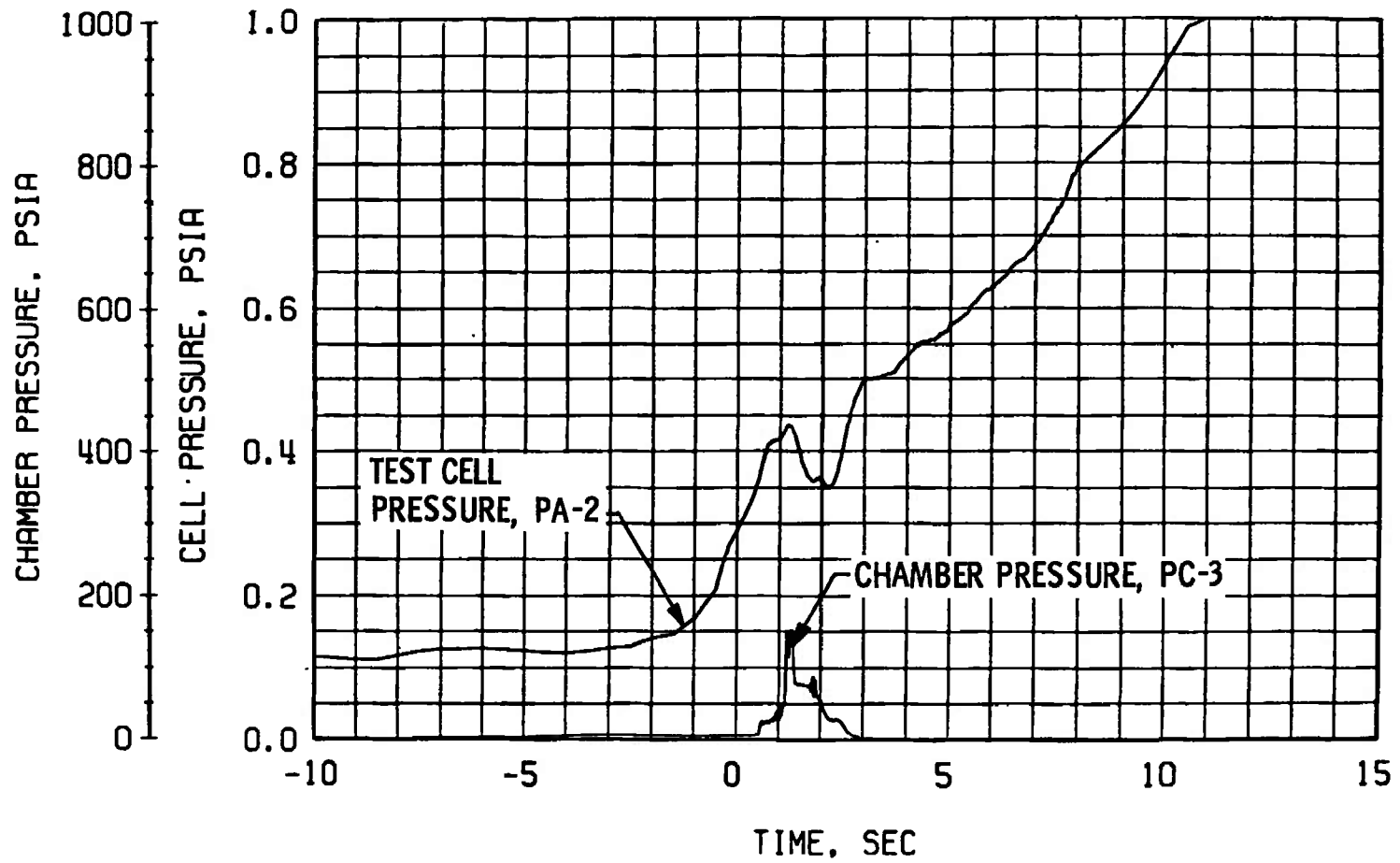

Fig. 64 Engine Ambient and Combustion Chamber Pressure, Firing 11F

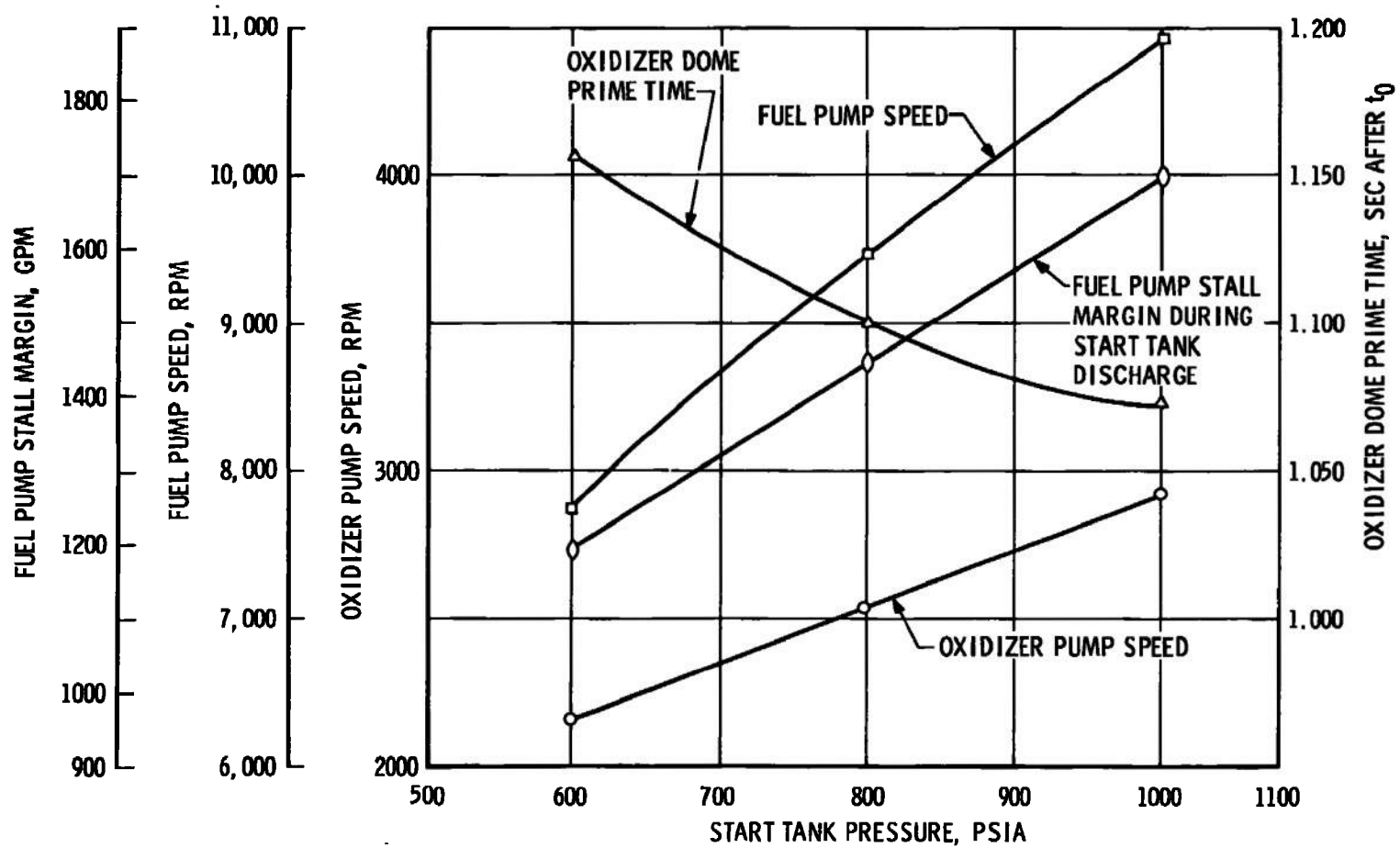

Fig. 65 Start Tank Pressure Effects on Engine Start Transient Performance

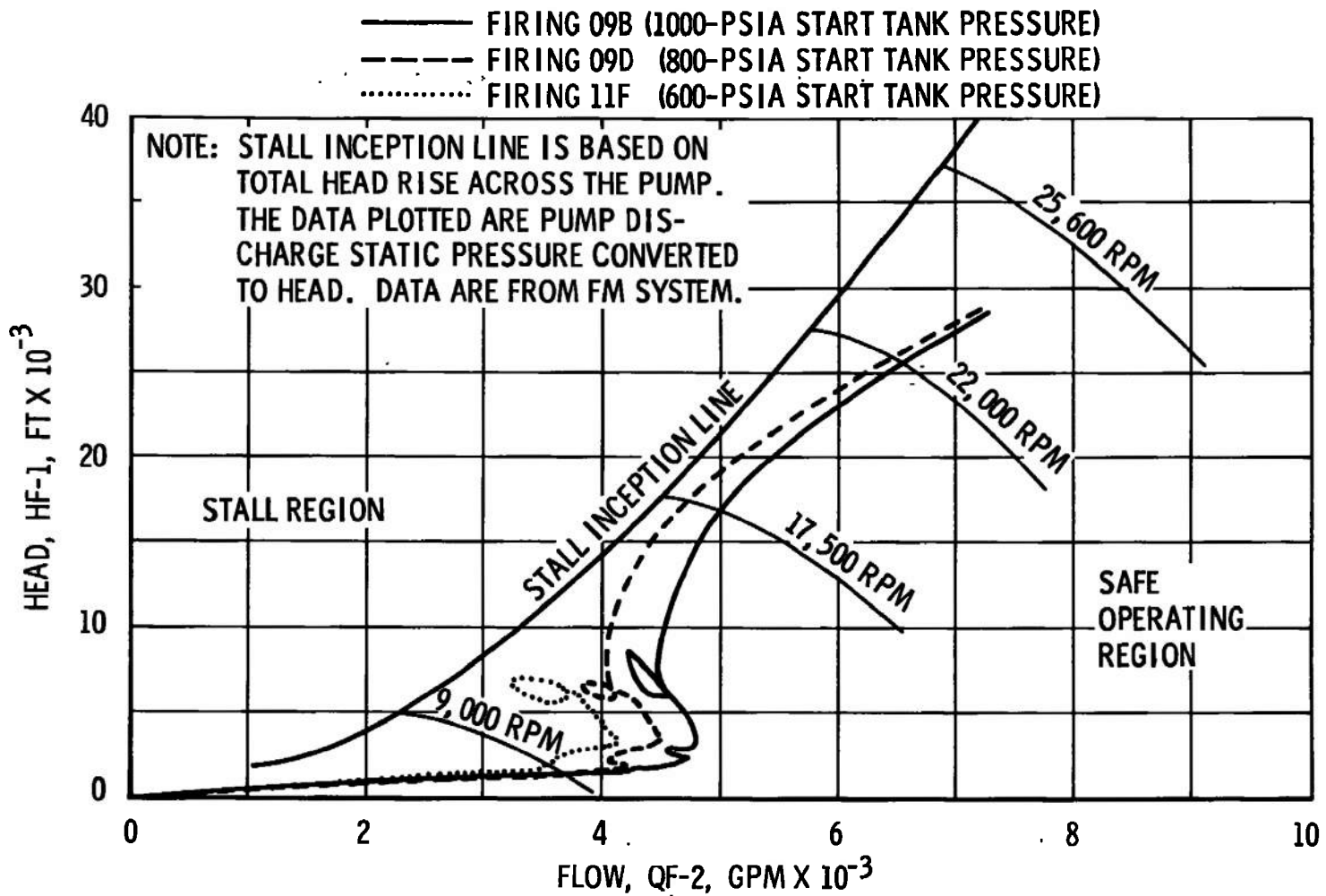

Fig. 66 Start Tank Pressure Effect on Fuel Pump Start Transient Performance

TABLE I
MAJOR ENGINE COMPONENTS

Part Name	P/N	S/N
Augmented Spark Igniter Assembly	309360-91	4071414
Augmented Spark Igniter Oxidizer Valve	308880	4079065
Auxiliary Flight Instrumentation Package	704090-21	4075163
Electrical Control Package	502870-51	4081748
Fuel Bleed Valve	309034	4084042
Fuel Flowmeter	251225	4074110
Fuel Injector Temperature Transducer	NA5-27441	AA013283F66
Fuel Turbopump Assembly	480390-181	4073647
Gas Generator Control Valve	309040-31	4078292
Gas Generator Fuel Injector and Combustor Assembly	308360-11	4090408
Gas Generator Oxidizer Injector and Poppet Assembly	303323	4092975
Helium Control Valve	NA5-27273	372452
Helium Regulator Assembly	558130-111	4061139
Helium Tank Vent Control Valve	NA5-27273	379313
Ignition Phase Control Valve	558069	8313398
Main Fuel Valve	409920	4074288
Main Oxidizer Valve	411031-21	4072666
Main-Stage Control Valve	558069	8284312
Oxidizer Bleed Valve	309029 (Tests 09 and 10)	4084035
	309029 (Test 11)	4078081
Oxidizer Flowmeter	251216	4075154
Oxidizer Turbine Bypass Valve	409940	4073096
Oxidizer Turbopump Assembly	458175-111	6610105
Pressure-Actuated Purge Control Valve	558126	4073862
Pressure-Actuated Shutdown Valve Assembly	558127-11	4074549
Primary Flight Instrumentation Package	704095-21	4074730
Propellant Utilization Valve	251351-51	4075182
Restartable Ignition Detect Probe	NA5-27298T2 (Test 09)	203
	NA5-27298T2 (Test 10)	315
	3243-2 (Test 11)	040
Start Tank	307579	0098
Start Tank Discharge Valve	304286	4086957
Start Tank Fill/Refill Valve	557998	4091617
Start Tank Vent and Relief Valve	557848	4080517
Thrust Chamber Body	15-205875	4082445
Thrust Chamber Injector Assembly	XEOR-933703	4089721

**TABLE II
SUMMARY OF ENGINE ORIFICES**

Orifice Name	Part Number	Diameter	Date Effective	Comments
Gas Generator Fuel Supply Line	RD251-4107	0.488 in.	July 15, 1968	
Gas Generator Oxidizer Supply Line	RD251-4106	0.284 in.	July 15, 1968	
Oxidizer Turbine Bypass Valve Nozzle	RD273-8002	1.520 in.	July 15, 1968	
Main Oxidizer Valve Closing Control Line	410437 410437-088 410437-084	8.40 scfm 8.75 scfm 8.40 scfm	August 16, 1968 September 5, 1968 September 13, 1968	Thermostatic Orifice
Oxidizer Turbine Exhaust Manifold	RD251-9004	10.00 in.	(1)	
Augmented Spark Igniter Oxidizer Supply Line	309358	0.125 in.	June 9, 1968	
Augmented Spark Igniter Fuel Supply Line	309355	0.302 in.	August 1, 1968	

(1) As delivered to AEDC

**TABLE III
ENGINE MODIFICATIONS
(BETWEEN TESTS J4-1901-09 AND J4-1901-11)**

Modification Number	Completion Date	Description of Modification
Test J4-1901-09		9/4/68
RFD ¹ -AEDC-46-68	9/5/68	Gas Generator Fuel Poppet Leakage Simulation Capability
RFD-AEDC-42-68	9/5/68	Changes to Gas Generator Oxidizer Valve Opening Time (150 ⁺⁵ ₋₀ Delay)
RFD-AEDC-19-68	9/5/68	Changes to Main Oxidizer Valve Second-Stage Opening Time (1650 ⁺¹⁰ ₋₂₀)
Test J4-1901-10		9/12/68
RFD-AEDC-12-68	9/13/68	Changes to Main Oxidizer Valve Second-Stage Opening Time (1700 ⁺²⁰ ₋₁₀)
RFD-AEDC-45-68	9/13/68	Deleted Insulation of Augmented Spark Igniter
RFD-AEDC-42-68	9/13/68	Deleted Changes to Gas Generator Oxidizer Valve
Test J4-1901-11		9/24/68

¹RFD - Rocketdyne Field Directive

**TABLE IV
ENGINE COMPONENT REPLACEMENTS
(BETWEEN TESTS J4-1901-09 AND J4-1901-11)**

Replacement	Completion Date	Component Replaced
Test J4-1901-09		9/4/68
UCR ¹ 005162	9/5/68	Augmented Spark Igniter Ignition Detector Probe
Test J4-1901-10		9/12/68
	9/13/68	Oxidizer Bleed Valve
	9/13/68	Gas Generator Oxidizer Supply Line
	9/13/68	Oxidizer Bleed Valve Temperature Transducer
UCR 005163	9/18/68	Augmented Spark Igniter Ignition Detector Probe
UCR 005170	9/18/68	Fuel Turbine Shaft Seal
	9/18/68	Fuel Turbopump Primary Shaft Seal
UCR 005170	9/18/68	Fuel Turbopump Intermediate Shaft Seal
Test J4-1901-11		9/24/68

¹UCR - Unsatisfactory Condition Report

TABLE V
ENGINE PURGE AND COMPONENT CONDITIONING SEQUENCE

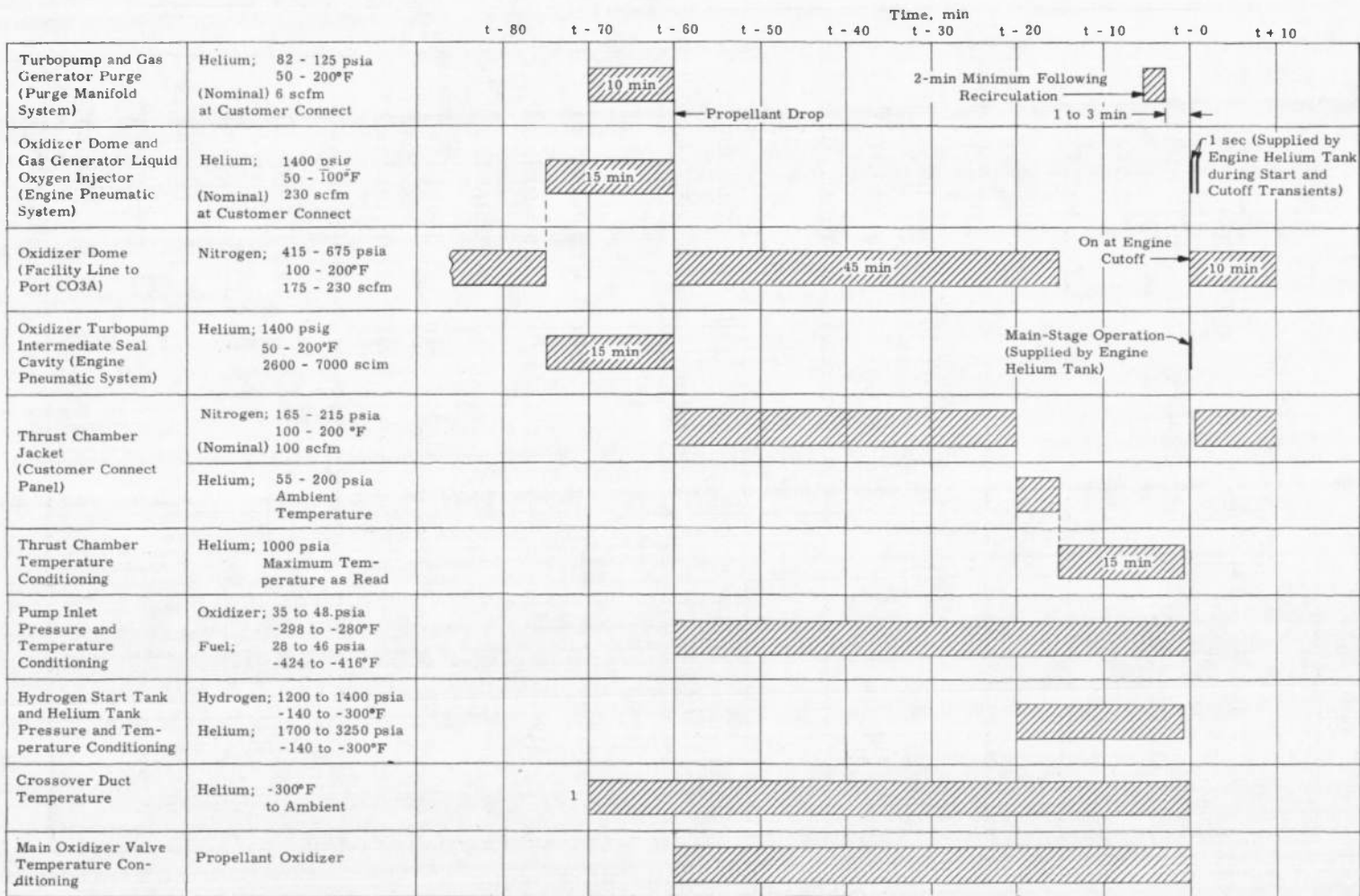

¹Conditioning temperature to be maintained for the last 30 min of pre-fire.

TABLE VI
SUMMARY OF TEST REQUIREMENTS AND RESULTS

Firing Number: J4-1901-9	A		B		C		D		E		F		
	Target	Actual	Target	Actual	Target	Actual	Target	Actual	Target	Actual	Target	Actual	
Time of Day, hr/Firing Date	1033 5/4/68		1104 5/4/68		1134 5/4/68		1451 5/4/68		1521 5/4/68		1621 5/4/68		
Pressure Altitude at Engine Start, ft (Ref. 1)	100,000	88,000	100,000	100,000	100,000	100,000	100,000	101,000	100,000	100,000	100,000	102,000	
Firing Duration, sec	32.5	1.248	32.5	32.573	7.5	7.587	32.5	32.573	7.5	7.587	34.0	0.677	
Fuel Pump Inlet Conditions at Engine Start	Pressure, psia	34.0 ± 1	33.6	34.0 ± 1	33.7	26.5 ⁺¹ ₋₀	26.9	34.0 ⁺¹ ₋₀	33.4	41.0 ± 1	40.7	34.0 ⁺¹ ₋₀	33.1
	Temperature, °F	-421.4 ± 0.4	-421.4	-421.4 ± 0.4	-421.8	-421.4 ± 0.4	-421.4	-421.4 ± 0.4	-421.7	-421.4 ± 0.4	-421.3	-421.4 ± 0.4	-421.1
Oxidizer Pump Inlet Conditions at Engine Start	Pressure, psia	40.0 ± 1	39.4	40.0 ± 1	39.6	45.0 ⁺¹ ₋₀	45.2	40.0 ⁺¹ ₋₀	38.3	45.0 ⁺¹ ₋₀	45.0	40.0 ± 1	39.0
	Temperature, °F	-295.0 ± 0.4	-295.3	-295.0 ± 0.4	-295.3	-295.0 ± 0.4	-295.1	-295.0 ± 0.4	-295.0	-295.0 ± 0.4	-284.6	-295.0 ± 0.4	-294.8
Start Tank Conditions at Engine Start	Pressure, psia	1200 ± 10	1185	1000 ± 10	997	1300 ± 10	1296	600 ± 10	760	1300 ± 10	1300	600 ± 10	602
	Temperature, °F	+50 ± 25	+42	-220 ± 10	-224	-265 ± 10	-272	-220 ± 10	226	-265 ± 10	-266	-220 ± 10	224
Helium Tank Conditions at Engine Start	Pressure, psia	---	2106	---	2205	---	2116	---	2169	---	2156	---	2163
	Temperature, °F	---	+41	---	-211	---	-262	---	-217	---	-259	---	-221
Thrust Chamber Temperature Conditions at Engine Start, °F	Throat	-50 ± 25	-59	-50 ± 25	-61	+50 ± 25	+82	-50 ± 25	-58	+50 ± 25	+89	-50 ± 25	-54
	Average Engine Near V ₀	---	-57/-351	---	-72/-365	---	+21/-284	---	-71/-355	---	+27/-334	---	-71/-347
Crossover Duct Temperature at Engine Start, °F	TFTD-2	+50 ± 25	+45	+50 ± 25	+44	---	+427	+50 ± 25	+43	---	+430	+50 ± 25	+37
	TFTD-3/-4	+50 ± 25	+58/+57	+50 ± 25	+55/+57	+170 ⁺¹⁵ ₋₀	+171/+171	+50 ± 25	+52/+56	+170 ⁺¹⁵ ₋₀	+171/+173	+50 ± 25	+43/+46
	TFTD-8	+50 ± 25	+45	+50 ± 25	+45	---	+423	+50 ± 25	+51	---	+424	+50 ± 25	+50
Main Oxidizer Valve Second-Stage Actuator Temperature at Engine Start, °F	-150 ± 50	-121	-150 ± 50	-150	-150 ± 50	-160	-150 ± 50	-176	-150 ± 50	-167	-150 ± 50	-169	
Fuel Lead Time, sec	6.0	7.820	8.0	7.824	6.0	7.932	6.0	7.936	6.0	7.937	8.0	7.932	
Propellant in Engine Time, min	0	83	0	30	---	30	0	196	---	28	0	60	
Propellant Recirculation Time, min	10	10	10	10	10	10	10	10	10	10	10	10	
Start Sequence Logic	Normal	Normal	Normal	Normal	Normal	Normal	Normal	Normal	Normal	Normal	Normal	Normal	
Gas Generator Oxidizer Supply Line Temperature at Engine Start, °F	TOBS-1	-100	+38	-100	+15	-100	-5	-100	+13	-100	-11	-100	-1
	TOBS-2	Minimum	+23	Minimum	+14	Minimum	0	Minimum	+16	Minimum	-6	Minimum	+13
	TOBS-2B	↓	+40	↓	+35	↓	+24	↓	+33	↓	+15	↓	+34
Start Tank Discharge Valve Opening Control Temperature at Engine Start, °F	---	+30	---	+21	---	-16	---	-32	---	-43	---	-55	
Vibration Safety Counts Duration (msec) and Occurrence Time (sec) from t ₀	---	38	---	20	---	5	---	22	---	6	---	---	
Gas Generator Outlet Temperature, °F	Initial Peak	---	652	---	829	---	1271	---	889	---	1353	---	---
	Second Peak	---	---	---	---	---	1533	---	---	---	1862	---	---
Thrust Chamber Ignition (P _c = 100 psia) Time, sec (Ref. t ₀)	---	1.075	---	1.073	---	0.945	---	1.102	---	0.847	---	---	
Main Oxidizer Valve Second-Stage Initial Movement, sec (Ref. t ₀)	---	1.005	---	1.014	---	1.100	---	1.011	---	1.114	---	---	
Main-Stage Pressure No. 2, sec (Ref. t ₀)	---	---	---	2.006	---	1.669	---	2.092	---	1.680	---	---	
Time Chamber Pressure Attains 550 psia, sec (Ref. t ₀)	---	---	---	2.658	---	2.056	---	2.741	---	2.068	---	---	
Propellant Utilization Valve Position, Engine Start/t ₀ + 10 sec	Open	Open	Open	Open	Open	Open	Open	Open	Open	Open	Open	Open	
	Closed	---	Closed	Closed	---	---	Closed	Closed	---	---	Closed	---	

- Notes: ① Data reduced from oscillogram.
 ② Component conditioning to be maintained within limits for last 15 min before engine start.
 ③ Component conditioning to be maintained within limits for last 30 min before engine start or coast duration, whichever is longer.
 ④ Propellants in engine time are dependent on main oxidizer valve temperature (30-min minimum).

TABLE VI (Continued)

Firing Number: J4-1901-10	A		B	
	Target	Actual	Target	Actual
Time of Day, hr/Firing Date	1154	9/12/68	1255	9/12/68
Pressure Altitude at Engine Start, ft (Ref. 1)	100,000	61,000	100,000	100,000
Firing Duration, sec [ⓐ]	7.5	7.582	7.5	7.582
Fuel Pump Inlet Conditions at Engine Start	Pressure, psia	26.5 ⁺¹ ₋₀	26.6	26.3 ⁺¹ ₋₀
	Temperature, °F	-421.4 ± 0.4	-421.5	-421.4 ± 0.4
Oxidizer Pump Inlet Conditions at Engine Start	Pressure, psia	33.0 ± 1	33.6	33.0 ± 1
	Temperature, °F	-295.0 ± 0.4	-295.1	-295.0 ± 0.4
Start Tank Conditions at Engine Start	Pressure, psia	1230 ± 10	1248	1200 ± 10
	Temperature, °F	-140 ± 10	-140	+90 ± 23
Helium Tank Conditions at Engine Start	Pressure, psia	---	2182	---
	Temperature, °F	---	-132	---
Thrust Chamber Temperature Conditions at Engine Start/t ₀ , °F	Throat	-200 ± 25	-224	-200 ± 25
	Average Engine Start/t ₀	---	-201/-366	---
Crossover Duct Temperature at Engine Start, °F [ⓐ]	TFTD-2	-100 ± 20	-103	-100 ± 20
	TFTD-3/-4	-100 ± 20	-73/-66	-100 ± 20
	TFTD-8	-100 ± 20	-66	-100 ± 20
Main Oxidizer Valve Second-Stage Actuator Temperature at Engine Start, °F [ⓐ]	-150 ± 50	-122	-150 ± 30	-135
Fuel Lead Time, sec [ⓐ]	8.0	-7.940	8.0	-7.937
Propellant in Engine Time, min	ⓐ	75	ⓐ	60
Propellant Recirculation Time, min	10	10	10	10
Start Sequence Logic	Normal	Normal	Normal	Normal
Gas Generator Oxidizer Supply Line Temperature at Engine Start, °F	TOBS-1	-100°F	+16	-100
	TOBS-2	Minimum	+20	Minimum
	TOBS-2B	---	+31	---
Start Tank Discharge Valve Opening Control Temperature at Engine Start, °F	---	39	---	0
Vibration Safety Counts Duration (maac) and Occurrence Time (sec) from t ₀	---	23 1.069	---	28 1.114
Gas Generator Outlet Temperature, °F	Initial Peak	---	659	---
	Second Peak	---	---	---
Thrust Chamber Ignition (P _c = 100 psia) Time, sec (Ref. t ₀) [ⓐ]	---	1.091	---	1.117
Main Oxidizer Valve Second-Stage Initial Movement, sec (Ref. t ₀) [ⓐ]	---	0.996	---	1.010
Main-Stage Pressure No. 2, sec (Ref. t ₀) [ⓐ]	---	2.269	---	2.303
Time Chamber Pressure Attains 330 psia, sec (Ref. t ₀)	---	3.158	---	3.033
Propellant Utilization Valve Position, Engine Start/t ₀ + 10 sec	Open	Open	Open	Open

- Notes:
- ⓐ Data reduced from oscillogram.
 - ⓑ Component conditioning to be maintained within limits for last 15 min before engine start.
 - ⓒ Component conditioning to be maintained within limits for last 30 min before engine start or coast duration, whichever is longer.
 - ⓓ Propellants in engine time are dependent on main oxidizer valve temperature (30-min minimum).

TABLE VI (Concluded)

Firing Number: J4-1901-11		11A		11B		11C		11D		11E		11F						
		Target	Actual	Target	Actual	Target	Actual	Target	Actual	Target	Actual	Target	Actual					
Time of Day, hr/Firing Date		1223	9/24/68	1253	9/24/68	1810	9/24/68	1840	9/24/68	1724	9/24/68	1837	9/24/68					
Pressure Altitude at Engine Start, ft (Ref. 1)		100,000	84,000	100,000	101,000	100,000	99,000	100,000	102,000	100,000	106,000	100,000	107,000					
Firing Duration, sec [ⓐ]		32.5	52,570	7.5	7,577	32.5	32,566	7.5	7,564	Main-Stage Pickup Signal	2.854	Main-Stage Pickup Signal	1.261					
Fuel Pump Inlet Conditions at Engine Start	Pressure, psia	27.0 ⁺¹ ₋₀	26.6	26.5 ⁺¹ ₋₀	26.7	41.0 ± 1	40.8	41 ± 1	40.7	26.5 ⁺¹ ₋₀	26.5	34.0 ± 1	33.8					
	Temperature, °F	-421.4 ± 0.4	-420.7	-421.4 ± 0.4	-421.0	-421.4 ± 0.4	-421.8	-421.4 ± 0.4	-421.0	-421.4 ± 0.4	-420.7	-421.4 ± 0.4	-420.6					
Oxidizer Pump Inlet Conditions at Engine Start	Pressure, psia	45.0 ⁺¹ ₋₀	44.6	45.0 ⁺¹ ₋₀	45.2	45.0 ⁺¹ ₋₀	45.5	45.0 ⁺¹ ₋₀	45.8	53.0 ± 1	35.8	40.0 ± 1	44.6					
	Temperature, °F	-295.0 ± 0.4	-294.9	-295.0 ± 0.4	-295.1	-295.0 ± 0.4	-295.1	-295.0 ± 0.4	-294.7	-295.0 ± 0.4	-294.0	-295.0 ± 0.4	-298.1					
Start Tank Conditions at Engine Start	Pressure, psia	1365 ± 10	1555	1500 ± 10	1308	1300 ± 10	1500	1300 ± 10	1296	1250 ± 10	1251	800 ± 10	802					
	Temperature, °F	-210 ± 10	-205	-285 ± 10	-287	-285 ± 10	-267	-255 ± 10	-267	-140 ± 10	-141	-220 ± 10	-210					
Helium Tank Conditions at Engine Start	Pressure, psia	---	2183	---	2191	---	2242	---	2235	---	2542	---	2280					
	Temperature, °F	---	-199	---	-257	---	-265	---	-266	---	-140	---	-222					
Thrust Chamber Temperature Conditions at Engine Start/ ₀ °F	Throat	-80 ⁺²⁰ ₋₁₀	-76	+50 ± 50	+51	+50 ± 50	-70	+50 ± 50	+73	-200 ± 25	-217	-80 ± 25	-87					
	Average Engine Start ₀	---	-99	---	+19/-281	---	-22	---	+35	---	-149	---	-85					
Crossover Duct Temperature at Engine Start, °F [ⓑ]	TFTD-2	50 ⁺³ ₋₅₀	15	---	591	---	-357	---	374	---	-341	+50 ± 25	50					
	TFTD-3/-4	---	28/27	+170 ⁺¹⁰ ₋₀	+185/+194	---	-301/-315	+170 ⁺¹⁵ ₋₀	+155/+182	---	-347/-365	---	+64/+68					
	TFTD-8	---	24	---	432	---	-241	---	388	---	-207	---	40					
Main Oxidizer Valve Second-Stage Actuator Temperature at Engine Start, °F [ⓑ]	-150 ± 50	-110	-150 ± 50	-130	-150 ± 50	-176	-150 ± 50	-156	-150 ± 50	-154	-150 ± 50	-176						
Fuel Lead Time, sec [ⓐ]	3.0	3.025	8.0	7.940	8.0	7.952	8.0	7.952	8.0	7.959	8.0	7.940						
Propellant in Engine Time, min	ⓐ	82	---	30	ⓐ	197	---	50	---	44	ⓐ	72						
Propellant Recirculation Time, min	10	11	10	14	10	19	10	11	10	10	10	10						
Start Sequence Logic	Normal	Normal	Normal	Normal	Normal	Normal	Normal	Normal	Normal	Normal	Normal	Normal						
Gas Generator Oxidizer Supply Line Temperature at Engine Start, °F	TOBS-1	---	+43	---	+20	---	-70	---	-11	---	-40	---	-16					
	TOBS-2	---	+27	---	+17	---	+15	---	+5	---	+7	---	+17					
	TOBS-2B	---	+40	---	+31	---	+36	---	+16	---	+55	---	+41					
Start Tank Discharge Valve Opening Control Temperature at Engine Start, °F	---	+56	---	+7	---	-46	---	-56	---	-54	---	-49						
Vibration Safety Counts Duration (msec) and Occurrence Time (sec) from ₀	---	5	0.994	---	8	0.951	---	11	1.690	---	6	0.850	---	19	1.252	---	31	1.152
Gas Generator Outlet Temperature, °F	Initial Peak	---	1807	---	1869	---	1470	---	1803	---	226	---	1551					
	Second Peak	---	---	---	1622	---	---	---	1842	---	---	---	---					
Thrust Chamber Ignition (P _c + 100 psia) Time, sec (Ref. ₀) [ⓐ]	---	0.986	---	0.949	---	1.066	---	0.950	---	1.162	---	1.156						
Main Oxidizer Valve Second-Stage Initial Movement, sec (Ref. ₀) [ⓐ]	---	1.046	---	1.074	---	0.895	---	1.110	---	1.009	---	1.017						
Main-Stage Pressure No. 2, sec (Ref. ₀) [ⓐ]	---	1.622	---	1.642	---	2.001	---	1.618	---	2.801	---	---						
Time Chamber Pressure Attains 550 psia, sec (Ref. ₀) [ⓐ]	---	1.885	---	2.012	---	2.916	---	2.019	---	---	---	---						
Propellant Utilisation Valve Position, Engine Start/ ₀ + 10 sec	Null	Closed	Null	Closed	Open	Open	Open	Closed	Open	Open	Open	Open	Open					

Notes: [ⓐ]Data reduced from oscillogram.
[ⓑ]Component conditioning to be maintained within limits for last 15 min before engine start.
[ⓐ]Component conditioning to be maintained within limits for last 30 min before engine start or coast duration, whichever is longer.
[ⓐ]Propellants in engine time are dependent on main oxidizer valve temperature (30-min minimum).

**TABLE VII
ENGINE VALVE TIMINGS**

Firing Number J4-1901-09	Start																							
	Start Tank Discharge Valve						Main Fuel Valvs			Main Oxidizer Valve First Stage			Main Oxidizer Valve Second Stage			Gas Generator Fuel Poppet			Gas Generator Oxidizer Poppet			Oxidizer Turbine Bypass Valve		
	Time of Opening Signal	Valve Delay Time, sec	Valve Opening Time, sec	Time of Closing Signal	Valvs Delay Time, sec	Valve Closing Time, sec	Time of Opening Signal	Valve Delay Time, sec	Valve Opening Time, sec	Time of Opening Signal	Valve Delay Time, sec	Valve Opening Time, sec	Time of Opening Signal	Valvs Delay Time, sec	Valve Opening Time, sec	Time of Opening Signal	Valve Delay Time, sec	Valve Opening Time, sec	Time of Opening Signal	Valve Delay Time, sec	Valvs Opening Time, sec	Time of Closing Signal	Valve Delay Time, sec	Valve Closing Time, sec
A	0.0	0.121	0.106	0.448	0.129	0.248	-7.820	0.078	0.105	0.448	0.058	0.053	0.448	0.557	---	0.448	0.107	0.033	0.448	0.181	0.074	0.448	0.218	0.284
B	0.0	0.118	0.101	0.449	0.128	0.249	-7.824	0.085	0.119	0.449	0.058	0.052	0.448	0.565	1.808	0.448	0.108	0.032	0.449	0.177	0.078	0.449	0.218	0.282
C	0.0	0.133	0.117	0.449	0.133	0.252	-7.932	0.080	0.119	0.449	0.058	0.053	0.449	0.851	1.789	0.449	0.109	0.034	0.449	0.182	0.081	0.449	0.216	0.281
D	0.0	0.118	0.110	0.447	0.134	0.259	-7.836	0.078	0.111	0.447	0.058	0.053	0.447	0.564	1.825	0.447	0.107	0.030	0.447	0.173	0.076	0.447	0.203	0.290
E	0.0	0.134	0.122	0.446	0.135	0.257	-7.837	0.079	0.124	0.446	0.058	0.054	0.446	0.668	1.797	0.448	0.111	0.032	0.446	0.144	0.086	0.448	0.214	0.282
F	0.0	0.117	0.109	0.447	0.132	---	-7.832	0.082	0.118	0.447	0.057	0.054	0.447	---	---	0.447	0.107	0.030	0.447	0.178	---	0.447	0.195	---
Final Sequence	0.0	0.088	0.090	0.451	0.128	0.242	-0.999	0.054	0.108	0.451	0.051	0.045	0.451	0.611	1.701	0.451	0.081	0.038	0.451	0.140	0.071	0.451	0.203	0.273

Firing Number J4-1901-09	Shutdown														
	Main Fuel Valve			Main Oxidizer Valve			Gas Generator Fuel Poppet			Gas Generator Oxidizer Poppet			Oxidizer Turbine Bypass Valve		
	Time of Closing Signal	Valve Delay Time, sec	Valve Closing Time, sec	Time of Closing Signal	Valve Delay Time, sec	Valve Closing Time, sec	Time of Closing Signal	Valve Delay Time, sec	Valve Closing Time, sec	Time of Closing Signal	Valvs Delay Time, sec	Valve Closing Time, sec	Time of Closing Signal	Valve Delay Time, sec	Valve Opening Time, sec
A	1.249	0.101	0.296	1.248	---	---	1.248	0.079	0.023	1.249	0.045	0.024	1.248	0.159	0.574
B	32.573	0.108	0.328	32.573	0.081	0.188	32.573	0.068	0.013	32.573	0.030	8.012	32.573	0.254	0.554
C	7.587	0.103	0.328	7.587	0.078	0.181	7.587	0.074	0.018	7.587	0.035	0.015	7.587	0.231	0.491
D	32.573	0.117	0.365	32.573	0.088	0.188	32.573	0.072	0.013	32.573	0.033	0.014	32.573	0.247	0.521
E	7.587	0.104	0.335	7.587	0.078	0.179	7.587	0.077	0.017	7.587	0.035	0.015	7.587	0.229	0.478
F	0.677	0.091	0.312	0.677	---	---	0.877	---	---	0.877	---	---	0.877	---	---
Final Sequence	---	0.078	0.225	---	0.054	0.122	---	0.093	0.038	---	0.081	0.025	---	0.221	0.592

- Notes: 1. All valve signal times are referenced to t_0 .
 2. Valve delay times is the time required for initial valve movement after the valve "open" or "closed" solenoid has been energized.
 3. Final sequences check is conducted without propellants and within 12 hr before testing.
 4. Data reduced from oscillogram.

TABLE VII (Continued)

Firing Number J4-1901-10	Start																							
	Start Tank Discharge Valve						Main Fuel Valve			Main Oxidizer Valve First Stage			Main Oxidizer Valve Second Stage			Gas Generator Fuel Poppet			Gas Generator Oxidizer Poppet			Oxidizer Turbine Bypass Valve		
	Time of Opening Signal	Valve Delay Time, sec	Valve Opening Time, sec	Time of Closing Signal	Valve Delay Time, sec	Valve Closing Time, sec	Time of Opening Signal	Valve Delay Time, sec	Valve Opening Time, sec	Time of Opening Signal	Valve Delay Time, sec	Valve Opening Time, sec	Time of Opening Signal	Valve Delay Time, sec	Valve Opening Time, sec	Time of Opening Signal	Valve Delay Time, sec	Valve Opening Time, sec	Time of Opening Signal	Valve Delay Time, sec	Valve Opening Time, sec	Time of Closing Signal	Valve Delay Time, sec	Valve Closing Time, sec
A	0.0	0.120	0.108	0.448	0.131	0.239	-7.940	0.091	0.099	0.448	0.052	0.053	0.448	0.550	1.716	0.448	0.107	0.036	0.448	0.194	0.096	0.448	0.213	0.287
B	0.0	0.122	0.107	0.447	0.129	0.256	-7.837	0.081	0.117	0.447	0.055	0.059	0.447	0.563	1.758	0.447	0.114	0.039	0.447	0.197	0.106	0.447	0.219	0.302
C																								
D																								
E																								
Final Sequence	0.0	0.090	0.091	0.450	0.127	0.239	-1.000	0.053	0.109	0.450	0.051	0.045	0.450	0.609	1.704	0.450	0.081	0.038	0.450	0.142	0.071	0.450	0.203	0.273

Firing Number J4-1901-10	Shutdown														
	Main Fuel Valve			Main Oxidizer Valve			Gas Generator Fuel Poppet			Gas Generator Oxidizer Poppet			Oxidizer Turbine Bypass Valve		
	Time of Closing Signal	Valve Delay Time, sec	Valve Closing Time, sec	Time of Closing Signal	Valve Delay Time, sec	Valve Closing Time, sec	Time of Closing Signal	Valve Delay Time, sec	Valve Closing Time, sec	Time of Closing Signal	Valve Delay Time, sec	Valve Closing Time, sec	Time of Opening Signal	Valve Delay Time, sec	Valve Opening Time, sec
A	7.582	0.106	0.319	7.582	0.081	0.172	7.582	0.076	0.015	7.582	0.038	0.016	7.582	0.256	0.573
B	7.582	0.114	0.346	7.582	0.082	0.179	7.582	0.081	0.018	7.582	0.038	0.017	7.582	0.261	0.571
C															
D															
E															
Final Sequence	---	0.077	0.226	---	0.055	0.121	---	0.093	0.039	---	0.061	0.021	---	0.222	0.591

- Notes:
1. All valve signal times are referenced to t_0 .
 2. Valve delay time is the time required for initial valve movement after the valve "open" or "closed" solenoid has been energized.
 3. Final sequence check is conducted without propellants and within 12 hr before testing.
 4. Data reduced from oscillogram.

TABLE VII (Concluded)

Firing Number J4-1801-11	Start																							
	Start Tank Discharge Valve						Main Fuel Valve			Main Oxidizer Valve First Stage			Main Oxidizer Valve Second Stage			Gas Generator Fuel Poppet			Gas Generator Oxidizer Poppet			Oxidizer Turbine Bypass Valve		
	Time of Opening Signal	Valve Delay Time, sec	Valve Opening Time, sec	Time of Closing Signal	Valve Delay Time, sec	Valve Closing Time, sec	Time of Opening Signal	Valve Delay Time, sec	Valve Opening Time, sec	Time of Opening Signal	Valve Delay Time, sec	Valve Opening Time, sec	Time of Opening Signal	Valve Delay Time, sec	Valve Opening Time, sec	Time of Opening Signal	Valve Delay Time, sec	Valve Opening Time, sec	Time of Opening Signal	Valve Delay Time, sec	Valve Opening Time, sec	Time of Closing Signal	Valve Delay Time, sec	Valve Closing Time, sec
11A	0	0.122	0.110	0.452	0.133	0.240	-3.024	0.067	0.098	0.452	0.050	0.048	0.452	0.588	1.872	0.452	0.100	0.031	0.452	0.180	0.081	0.452	0.207	0.284
11B	0	0.130	0.116	0.450	0.130	0.250	-7.838	0.070	0.106	0.450	0.053	0.045	0.450	0.820	1.828	0.450	0.107	0.032	0.450	0.189	0.095	0.450	0.204	0.280
11C	0	0.140	0.126	0.449	0.136	0.263	-7.852	0.070	0.109	0.449	0.053	0.048	0.448	0.545	1.810	0.449	0.110	0.040	0.449	0.209	0.118	0.449	0.219	0.283
11D	0	0.138	0.126	0.447	0.126	0.257	-7.952	0.110	0.090	0.447	0.053	0.046	0.447	0.854	1.806	0.447	0.114	0.040	0.447	0.213	0.125	0.447	0.206	0.285
11E	0	0.129	0.120	0.448	0.133	0.258	-7.839	0.072	0.110	0.449	0.055	0.047	0.449	0.558	---	0.449	0.109	0.037	0.449	0.195	0.103	0.448	---	---
11F	0	0.106	0.110	0.448	0.134	0.266	-7.840	0.070	0.110	0.448	0.050	0.050	0.448	0.565	---	0.448	0.108	0.035	0.448	0.180	0.104	0.448	0.204	0.308
Final Sequence	0	0.087	0.091	0.450	0.126	0.242	-1.002	0.046	0.104	0.450	0.058	0.41	0.450	0.568	1.730	0.450	0.078	0.035	0.450	0.144	0.071	0.450	0.181	0.285

Firing Number J4-1901-11	Shutdown														
	Main Fuel Valve			Main Oxidizer Valve			Gas Generator Fuel Poppet			Gas Generator Oxidizer Poppet			Oxidizer Turbine Bypass Valve		
	Time of Closing Signal	Valve Delay Time, sec	Valve Closing Time, sec	Time of Closing Signal	Valve Delay Time, sec	Valve Closing Time, sec	Time of Closing Signal	Valve Delay Time, sec	Valve Closing Time, sec	Time of Closing Signal	Valve Delay Time, sec	Valve Closing Time, sec	Time of Closing Signal	Valve Delay Time, sec	Valve Closing Time, sec
11A	32.570	0.100	0.286	32.570	0.075	0.177	32.570	0.070	0.023	32.570	0.030	0.014	32.570	0.235	0.564
11B	7.586	0.099	0.284	7.586	0.075	0.174	7.586	0.074	0.821	7.586	0.034	0.018	7.586	0.222	0.530
11C	32.566	0.112	0.352	32.566	0.085	0.190	32.566	0.091	0.021	32.566	0.030	0.021	32.566	0.295	0.975
11D	7.584	0.101	0.336	7.584	0.075	0.180	7.584	0.092	0.022	7.584	0.040	0.025	7.584	0.254	0.842
11E	2.654	0.105	0.335	2.654	---	---	2.654	0.102	0.030	2.654	0.048	0.025	2.654	0.242	---
11F	1.265	0.107	0.340	1.265	---	---	1.265	0.100	0.030	1.265	0.058	0.030	1.265	0.175	1.322
Final Sequence	5.857	0.077	0.222	5.857	0.058	0.121	5.657	0.134	0.041	5.657	0.061	0.025	5.857	0.217	0.587

- Notes: 1. All valve signal times are referenced to t_p .
 2. Valve delay time is the time required for initial valve movement after the valve "open" or "closed" solenoid has been energized.
 3. Final sequence check is conducted without propellants and within 12 hr before testing.
 4. Data reduced from oscillogram.

**TABLE VIII
ENGINE PERFORMANCE SUMMARY**

Firing Number J4-1901-09		09B		09D		11A		11C	
		Site	Normalized	Site	Normalized	Site	Normalized	Site	Normalized
Overall Engine Performance	Thrust, lb _f	227,781	225,408	227,602	225,560	228,542	226,533	228,989	226,869
	Chamber Pressure, psia	780	768	780	769	783	772	784	773
	Mixture Ratio	5.62	5.63	5.63	5.65	5.61	5.61	5.56	5.60
	Fuel Weight Flow, lb _m /sec	82.0	80.7	81.8	80.5	82.5	81.3	83.1	81.6
	Oxidizer Weight Flow, lb _m /sec	461.0	454.4	460.8	454.9	462.7	456.0	462.4	456.7
	Total Weight Flow, lb _m /sec	543.0	535.0	542.6	535.5	545.2	537.3	545.5	538.3
Thrust Chamber Performance	Mixture Ratio	5.83	5.84	5.84	5.86	5.82	5.82	5.77	5.81
	Total Weight Flow, lb _m /sec	536.0	528.1	535.7	528.6	538.1	530.4	538.5	531.3
	Characteristic Velocity, ft/sec	7977	7971	7976	7970	7977	7976	7982	7969
Fuel Turbopump Performance	Pump Efficiency, percent	73.8	73.8	73.9	73.9	73.7	73.7	73.9	73.9
	Pump Speed, rpm	26,317	26,154	26,319	26,126	26,507	26,341	26,522	26,307
	Turbine Efficiency, percent	58.6	58.5	58.6	58.5	59.2	59.1	59.4	59.2
	Turbine Pressure Ratio	7.34	7.33	7.32	7.32	7.34	7.34	7.32	7.31
	Turbine Inlet Temperature, °F	1275	1260	1276	1259	1276	1258	1271	1257
	Turbine Weight Flow, lb _m /sec	6.96	6.88	6.94	6.88	7.03	6.93	7.01	6.94
Oxidizer Turbopump Performance	Pump Efficiency, percent	80.3	80.3	80.3	80.3	80.3	80.3	80.3	80.3
	Pump Speed, rpm	8670	8601	8672	8604	8697	8627	8700	8630
	Turbine Efficiency, percent	49.5	49.3	49.6	49.4	49.0	48.8	49.7	49.5
	Turbine Pressure Ratio	2.58	2.58	2.58	2.58	2.59	2.59	2.59	2.59
	Turbine Inlet Temperature, °F	840	829	842	831	850	837	830	821
	Turbine Weight Flow, lb _m /sec	6.08	6.02	6.06	6.01	6.15	6.09	6.12	6.06
Gas Generator Performance	Mixture Ratio	0.985	0.975	0.985	0.975	0.985	0.974	0.982	0.974
	Chamber Pressure, psia	681	672	679	671	688	680	685	677

- Notes: 1. Site data are calculated from test data.
 2. Normalized data are corrected to standard pump inlet and engine ambient pressure conditions.
 3. Input data are test data averaged from 29 to 30 sec, except as noted.
 4. Site and normalized data were computed using the Rocketdyne PAST 640 modification zero computer program.

APPENDIX III INSTRUMENTATION

The instrumentation for AEDC tests J4-1901-09 through 11 is tabulated in Table III-1. The location of selected major engine instrumentation is shown in Fig. III-1. The same instrumentation applies for all three tests.

TABLE III-1
INSTRUMENTATION LIST (FOR TESTS J4-1901-09 THROUGH J4-1901-11)

<u>AEDC Code</u>	<u>Parameter</u>	<u>Tap No.</u>	<u>Range</u>	<u>Micro-sadic</u>	<u>Magnetic Tape</u>	<u>Oscillo-graph</u>	<u>Strip Chart</u>	<u>X-Y Plotter</u>
	<u>Current</u>		<u>amps</u>					
ICC	Control		0 to 30	x		x		
IIC	Ignition		0 to 30	x		x		
	<u>Event</u>							
EASIOV	Augmented Spark Igniter Oxidizer Valve		Open/Closed	x		x		
EECL	Engine Cutoff Lockin		On/Off	x		x		
EECO	Engine Cutoff Signal		On/Off	x	x	x		
EES	Engine Start Command		On/Off	x		x		
EFBVC	Fuel Bleed Valve Closed Limit		Open/Closed	x				
EFPVC/O	Fuel Prevalve Closed/Open Limit		Closed/Open	x				
EHCS	Helium Control Solenoid		On/Off	x		x		
ELD	Ignition Detected		On/Off	x		x		
EIPCS	Ignition Phase Control Solenoid		On/Off	x		x		
EMCS	Main-Stage Control Solenoid		On/Off	x		x		
EMP-1	Main-Stage Pressure No. 1		On/Off	x		x		
EMP-2	Main-Stage Pressure No. 2		On/Off	x		x		
EOBVC	Oxidizer Bleed Valve Closed Limit		Open/Closed	x				
EOPVC	Oxidizer Prevalve Closed Limit		Closed	x		x		
EOPVO	Oxidizer Prevalve Open Limit		Open	x		x		
ESTDCS	Start Tank Discharge Control Solenoid		On/Off	x	x	x		
RASIS-1	Augmented Spark Igniter Spark No. 1		On/Off			x		
RASIS-2	Augmented Spark Igniter Spark No. 2		On/Off			x		
RGGS-1	Gas Generator Spark No. 1		On/Off			x		
RGGS-2	Gas Generator Spark No. 2		On/Off			x		
	<u>Flows</u>		<u>gpm</u>					
QF-1A	Fuel	PFF	0 to 9000	x		x		
QF-2	Fuel	PFFA	0 to 9000	x	x	x		
QF-1SAM	Fue. Flow Seal Approach Monitor		0 to 9000	x		x		
QFRP	Fuel Recirculation		0 to 160	x				
QO-1A	Oxidizer	POF	0 to 3000	x		x		
QO-2	Oxidizer	POFA	0 to 3000	x	x	x		
QORP	Oxidizer Recirculation		0 to 50	x				
	<u>Position</u>		<u>Percent Open</u>					
LFVT	Main Fuel Valve		0 to 100	x		x		
LGGVT	Gas Generator Valve		0 to 100	x		x		
LOTBVT	Oxidizer Turbine Bypass Valve		0 to 100	x		x		
LOVT	Main Oxidizer Valve		0 to 100	x		x		
LPUTOP	Propellant Utilization Valve		0 to 100	x		x	x	
LSTDVT	Start Tank Discharge Valve		0 to 100	x		x		
	<u>Pressure</u>		<u>psia</u>					
PA1	Test Cell		0 to 0.5	x		x		
PA2	Test Cell		0 to 1.0	x	x			
PA3	Test Cell		0 to 5.0	x			x	

TABLE III-1 (Continued)

<u>AEDC Code</u>	<u>Parameter</u>	<u>Tap No.</u>	<u>Range</u>	<u>Micro-sadic</u>	<u>Magnetic Tape</u>	<u>Oscillo-graph</u>	<u>Strip Chart</u>	<u>X-Y Plotter</u>
	<u>Pressure</u>		<u>psia</u>					
PC-1P	Thrust Chamber	CG1	0 to 1000	x				
PC-3	Thrust Chamber	CG1A	0 to 1000	x	x	x		
PCBO-1	Constant Bleed Orifice		0 to 50	x				
PCDP	Crossover Duct Purge		0 to 100	x				
PCGG-1P	Gas Generator Chamber		0 to 1000	x	x	x		
PCGG-2	Gas Generator Chamber	GG1A	0 to 1000	x				
PFBL	Fuel Bleed Line		0 to 100	x		x		
PFJ-1A	Main Fuel Injection	CF2	0 to 1000	x		x		
PFJGG-1A	Gas Generator Fuel Injection	GF4	0 to 1000	x				
PFJGG-2	Gas Generator Fuel Injection	GF4	0 to 1000	x		x		
PFPC-1A	Fuel Pump Balance Piston Cavity	PF5	0 to 1000	x				
PFPD-1P	Fuel Pump Discharge	PF3	0 to 1500	x				
PFPD-2	Fuel Pump Discharge	PF2	0 to 1500	x	x	x		
PFPI-1	Fuel Pump Inlet		0 to 100	x		x		x
PFPI-2	Fuel Pump Inlet		0 to 100	x		x		x
PFPI-3	Fuel Pump Inlet		0 to 200		x			
PFPPSD-1	Fuel Pump Primary Seal Drain		0 to 200	x				
PFRPO	Fuel Recirculation Pump Outlet		0 to 60	x				
PFRPR	Fuel Recirculation Pump Return		0 to 50	x				
PFST-1P	Fuel Start Tank	TF1	0 to 1500	x		x		
PFST-2	Fuel Start Tank	TF1	0 to 1500	x				x
PFUT	Fuel Tank Ullage		0 to 100	x				
PFVI	Fuel Tank Pressurization Line Nozzle Inlet		0 to 1000	x				
PFVL	Fuel Tank Pressurization Line Nozzle Throat		0 to 1000	x				
PHECMO	Pneumatic Control Module Outlet		0 to 750	x				
PHEOP	Oxidizer Recirculation Pump Purge		0 to 150	x				
PHET-1P	Helium Tank	NN1	0 to 3500	x		x		
PHET-2	Helium Tank	NN1	0 to 3500	x				x
PHRO-1A	Helium Regulator Outlet	NN2	0 to 750	x				
POJ-1A	Main Oxidizer Injection	CO3	0 to 1000	x		x		
POJ-2	Main Oxidizer Injection	CO3A	0 to 1000	x		x		
POJ-3	Main Oxidizer Injection		0 to 2000		x			
POJGG-1A	Gas Generator Oxidizer Injection	GO5	0 to 1000	x		x		
POJGG-2	Gas Generator Oxidizer Injection	GO5	0 to 1000	x				
POPBC-1A	Oxidizer Pump Bearing Coolant	PO7	0 to 500	x				
POPD-1P	Oxidizer Pump Discharge	PO3	0 to 1500	x				
POPD-2	Oxidizer Pump Discharge	PO2	0 to 1500	x	x	x		
POPI-1	Oxidizer Pump Inlet		0 to 100	x				x
POPI-2	Oxidizer Pump Inlet		0 to 200	x				x
POPI-3	Oxidizer Pump Inlet		0 to 100			x		
POPSC-1A	Oxidizer Pump Primary Seal Cavity	PO6	0 to 50	x				

TABLE III-1 (Continued)

<u>AFDC Code</u>	<u>Parameter</u>	<u>Tap No.</u>	<u>Range</u>	<u>Micro- sanic</u>	<u>Magnetic Tape</u>	<u>Oscillo- graph</u>	<u>Strip Chart</u>	<u>X-Y Plotter</u>
<u>Pressure</u>				<u>psia</u>				
PORPO	Oxidizer Recirculation Pump Outlet		0 to 1.5	x				
PORPR	Oxidizer Recirculation Pump Return		0 to 100	x				
POT1-1A	Oxidizer Turbine Inlet	TC3	0 to 200	x				
POTO-1A	Oxidizer Turbine Outlet	TC4	0 to 100	x				
POUT	Oxidizer Tank Ullage		0 to 100	x				
POVCC	Main Oxidizer Valve Closing Control		0 to 500	x				
POVT	Oxidizer Tank Pressurization Line Nozzle Inlet		0 to 1000	x				
POVL	Oxidizer Tank Pressurization Line Nozzle Throat		0 to 1000	x				
PPUVI-1A	Propellant Utilization Valve Inlet	PO8	0 to 1500	x				
PPUVO-1A	Propellant Utilization Valve Outlet	PO9	0 to 500	x				
PTCFJP	Thrust Chamber Fuel Jacket Purge		0 to 100	x				
PTCP	Thrust Chamber Purge		0 to 1000	x				
PTFP	Turbopump and Gas Generator Purge		0 to 250	x				
<u>Speeds</u>				<u>rpm</u>				
NFP-1P	Fuel Pump	PFV	0 to 30,000	x	x	x		
NFRP	Fuel Recirculation Pump		0 to 15,000	x				
NOP-1P	Oxidizer Pump	POV	0 to 12,000	x	x	x		
NORP	Oxidizer Recirculation Pump		0 to 15,000	x				
<u>Temperatures</u>				<u>°F</u>				
TA1	Test Cell (North)		-50 to +800	x				
TA2	Test Cell (East)		-50 to +800	x				
TA3	Test Cell (South)		-50 to +800	x				
TA4	Test Cell (West)		-50 to +800	x				
TAIP-1A	Auxiliary Instrument Package		-300 to +200	x				
TAIPAA	Auxiliary Instrument Package Area Ambient		-200 to +500	x				
TCDP	Crossover Duct Purge		-150 to +150	x				
TECP-1P	Electrical Controls Package	NST1A	-300 to +200	x			x	
TEHAA	Engine Handler Attach Area Ambient		-200 to +500	x				
TFASIL-2	Augmented Spark Igniter Fuel Line Skin		-400 to +300	x				
TFASIL-4	Augmented Spark Igniter Fuel Line Skin		-425 to +500	x				
TFBV-1A	Fuel Bleed Valve	GFT1	-425 to -375	x				
TFD-1	Fire Detection		0 to 1000	x			x	
TFDAA	Fuel High Pressure Duct Area Ambient		-200 to +500	x				
TFJ-1P	Main Fuel Injection	CFT2	-425 to +250	x		x		
TFJ-2	Main Fuel Injection		-450 to +250	x				
TFPD-1P	Fuel Pump Discharge	PFT1	-425 to -400	x	x	x		
TFPD-2	Fuel Pump Discharge	PFT1	-425 to -400	x				
TFPI-1	Fuel Pump Inlet		-425 to -400	x				x
TFPI-2	Fuel Pump Inlet		-425 to -400	x				x
TFRPO	Fuel Recirculation Pump Outlet		-425 to -350	x				

TABLE III-1 (Continued)

<u>AFDC Code</u>	<u>Parameter</u>	<u>Trp No.</u>	<u>Range</u>	<u>Micro-sadic</u>	<u>Magnetic Tape</u>	<u>Oscillo-graph</u>	<u>Strip Chart</u>	<u>X-Y Plotter</u>
	<u>Temperatures</u>		<u>°F</u>					
TFRPR	Fuel Recirculation Pump Return Line		-425 to -250	x				
TFRT-1	Fuel Tank		-425 to -410	x				
TFRT-3	Fuel Tank		-425 to -410	x				
TFST-1P	Fuel Start Tank	TFT1	-350 to +150	x				
TFST-2	Fuel Start Tank	TFT1	-350 to +150	x				x
TFTD-2	Fuel Turbine Discharge Duct		-200 to +1000	x			x	
TFTD-3	Fuel Turbine Discharge Duct		-200 to -1000	x			x	
TFTD-4	Fuel Turbine Discharge Duct		-200 to -1000	x			x	
TFTD-#	Fuel Turbine Discharge Duct		-200 to +1400	x			x	
TFTO	Fuel Turbine Outlet	TGT2	0 to 1800	x				
TFTSD-1	Fuel Turbine Seal Drain Line		-300 to +100	x				
GGO-1A and 2	Gas Generator Outlet	GGT1	0 to 2500	x		x	x	
TGGVRS	Gas Generator Valve Retaining Screw		-100 to -100	x				
THET-1P	Helium Tank	NNT1	-350 to +100	x				x
TNODP	Oxidizer Dome Purge		0 to +300	x				
TOASIL-1	Augmented Spark Igniter Oxidizer Line Skin		-425 to -500	x				
TOASIL-2	Augmented Spark Igniter Oxidizer Line Skin		-400 to -300	x				
TOBS-1	Oxidizer Bootstrap Line		-300 to 250	x				
TOBS-2	Oxidizer Bootstrap Line		-300 to 250	x				
TOBS-2B	Oxidizer Bootstrap Line		-300 to +250	x				
TOBV-1A	Oxidizer Bypass Valve	GOT2	-300 to -250	x				
TODAA	Oxidizer Dome Area Ambient		-200 to +500	x				
TODS-1	Oxidizer Dome Skin		-300 to +100	x			x	
TODS-2	Oxidizer Dome Skin		-300 to +100	x			x	
TOPS-1A	Oxidizer Pump Bearing Coolant	POT4	-300 to -250	x				
TOPD-1P	Oxidizer Pump Discharge	POT3	-300 to -250	x	x	x	x	
TOPD-2	Oxidizer Pump Discharge	POT3	-300 to -250	x				
TOPI-1	Oxidizer Pump Inlet		-310 to -270	x				x
TOPI-2	Oxidizer Pump Inlet		-310 to -270	x				x
TORPO	Oxidizer Recirculation Pump Outlet		-300 to -250	x				
TORPR	Oxidizer Recirculation Pump Return		-300 to -250	x				
TORT-1	Oxidizer Tank		-300 to -287	x				
TORT-1B	Oxidizer Tank		-300 to -287	x				
TORT-3	Oxidizer Tank		-300 to -287	x				
TOTI-1P	Oxidizer Turbine Inlet	TGT3	-300 to 1200	x			x	
TOTO-1P	Oxidizer Turbine Outlet	TGT4	0 to 1500	x				
TOVL	Oxidizer Tank Pressurization Line Nozzle Throat		-300 to -100	x				
TPIP-1P	Primary Instrument Package		-300 to -200	x				

TABLE III-1 (Concluded)

<u>AEDC Code</u>	<u>Parameter</u>	<u>Tap No.</u>	<u>Range</u>	<u>Micro-sacic</u>	<u>Magnetic Tape</u>	<u>Oscillo-graph</u>	<u>Strip Chart</u>	<u>X-Y Plotter</u>
<u>Temperatures</u>			<u>°F</u>					
TPIPA	Primary Instrument Package Area Ambient		-200 to +500	x				
TSC2-1	Thrust Chamber Skin		-300 to +500	x				
TSC2-12	Thrust Chamber Skin		-300 to +500	x				
TSC2-13	Thrust Chamber Skin		-300 to +500	x			x	
TSC2-17	Thrust Chamber Skin		-300 to +500	x				
TSC2-20	Thrust Chamber Skin		-300 to +500	x				
TSC2-24	Thrust Chamber Skin		-300 to +500	x				
TSOVC-1	Oxidizer Valve Actuator Cap	NST	-325 to +150	x			x	
TSTDVAA	Start Tank Discharge Valve Area Ambient		-200 to +500	x				
TSTDVDL	Start Tank Discharge Valve Drain Line Port		-100 to +200	x				
TSTDVOC	Start Tank Discharge Valve Opening Control Port		-300 to +200	x				
TTC-1P	Thrust Chamber Jacket (Control)	CS1	-425 to +500	x			x	
TTC-2	Thrust Chamber Jacket	CS1A	-425 to +100	x				
TTCP	Thrust Chamber Purge		-346 to +534	x				
TTPP	Turbopump Purge		-150 to +150	x			x	
<u>Vibrations</u>			<u>g</u>					
UASIF-1	Augmented Spark Igniter Fuel Orifice Block Tangential		±150	x				
UASIV-1	Augmented Spark Igniter Oxidizer Valve Axial		±150	x				
UASIV-3	Augmented Spark Igniter Oxidizer Valve Tangential		±150	x				
UFPR	Fuel Pump Radial 90 deg		±300		x	x		
UMFV-1	Main Fuel Valve Radial		±150	x				
UMFV-3	Main Fuel Valve Tangential		±150	x				
UOPR	Oxidizer Pump Radial 90 deg		±200		x			
UOTBV-1	Oxidizer Turbine Bypass Valve Axial		±150		x			
UTCD-1	Thrust Chamber Dome		±500		x	x		
UTCD-2	Thrust Chamber Dome		±500		x	x		
UTCD-3	Thrust Chamber Dome		±500		x			
UTCD-4	Thrust Chamber Dome		±1000				x	
U1VSC	No. 1 Vibration Safety Counts		On/Off				x	
U2VSC	No. 2 Vibration Safety Counts		On/Off				x	
U3VSC	No. 3 Vibration Safety Counts		On/Off				x	
<u>Voltage</u>			<u>volts</u>					
VCB	Control Bus		0 to 36	x			x	
VIB	Ignition Bus		0 to 36	x			x	
VIDA	Ignition Detect Amplifier		0 to 16	x			x	
VPLTEP	Propellant Utilization Valve Excitation		0 to 5	x				

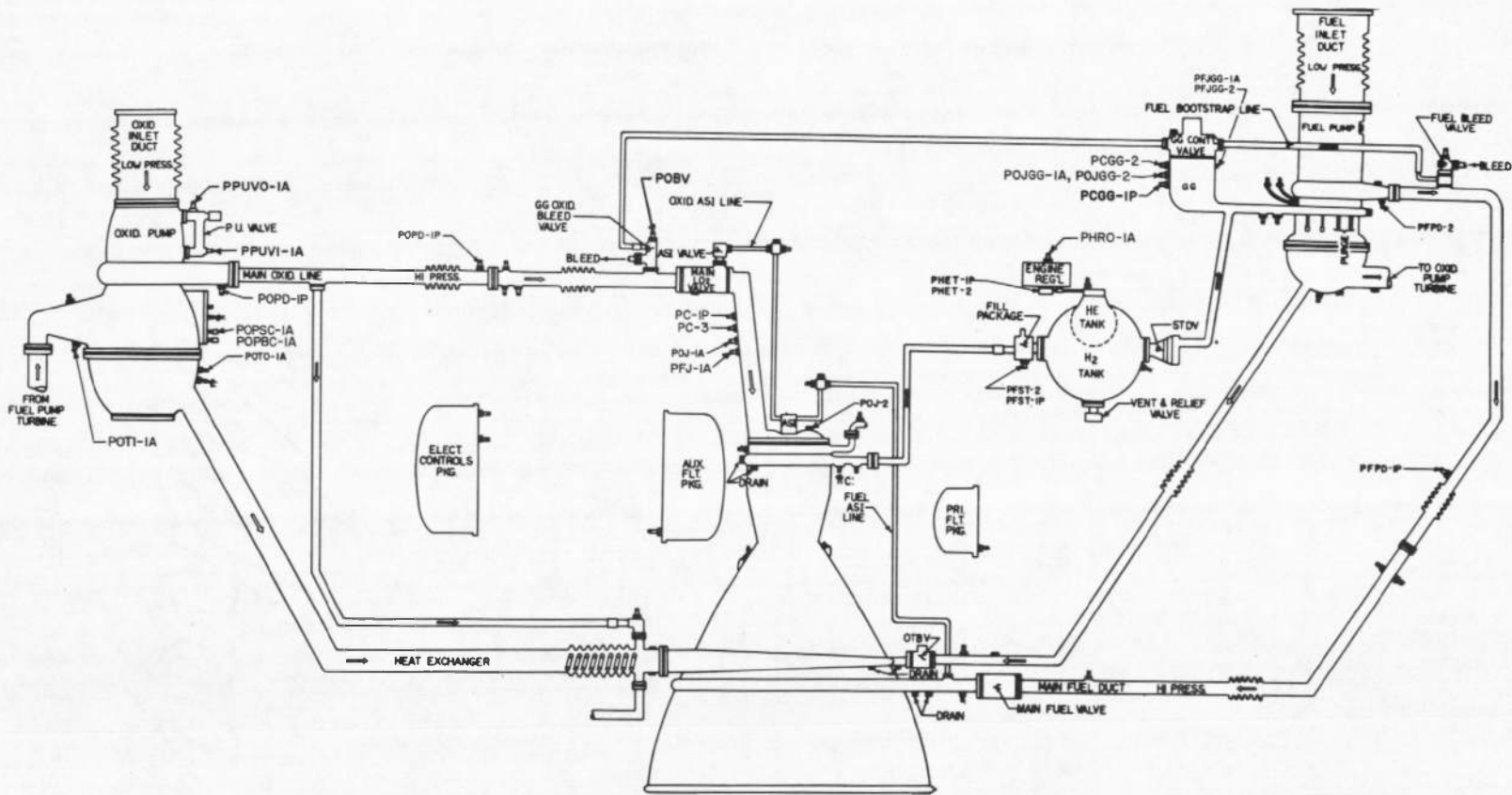

a. Engine Pressure Tap Locations
Fig. III-1 Instrumentation Locations

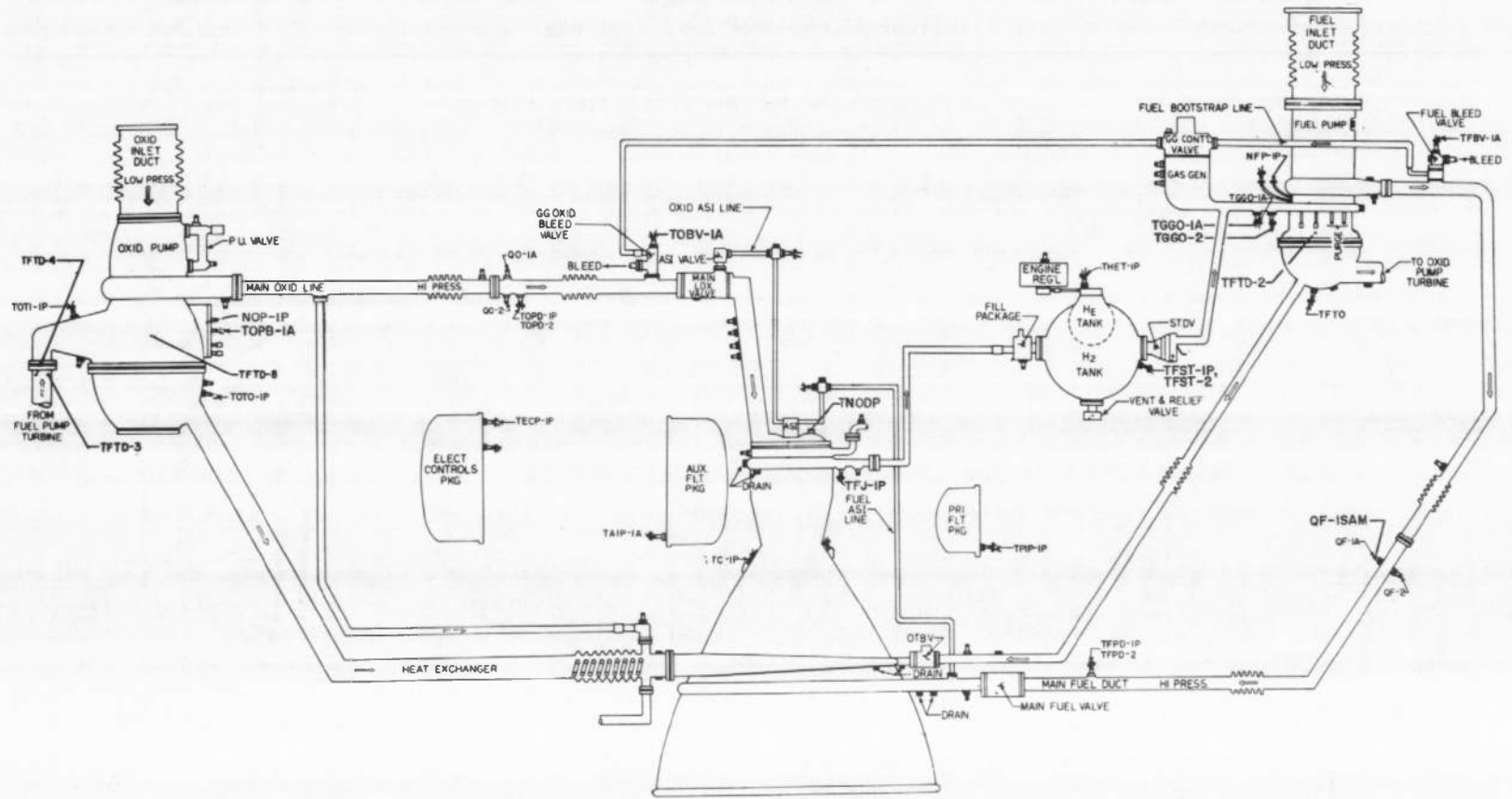

b. Engine Temperature, Flow, and Speed. Instrumentation Locations
 Fig. III-1 Continued

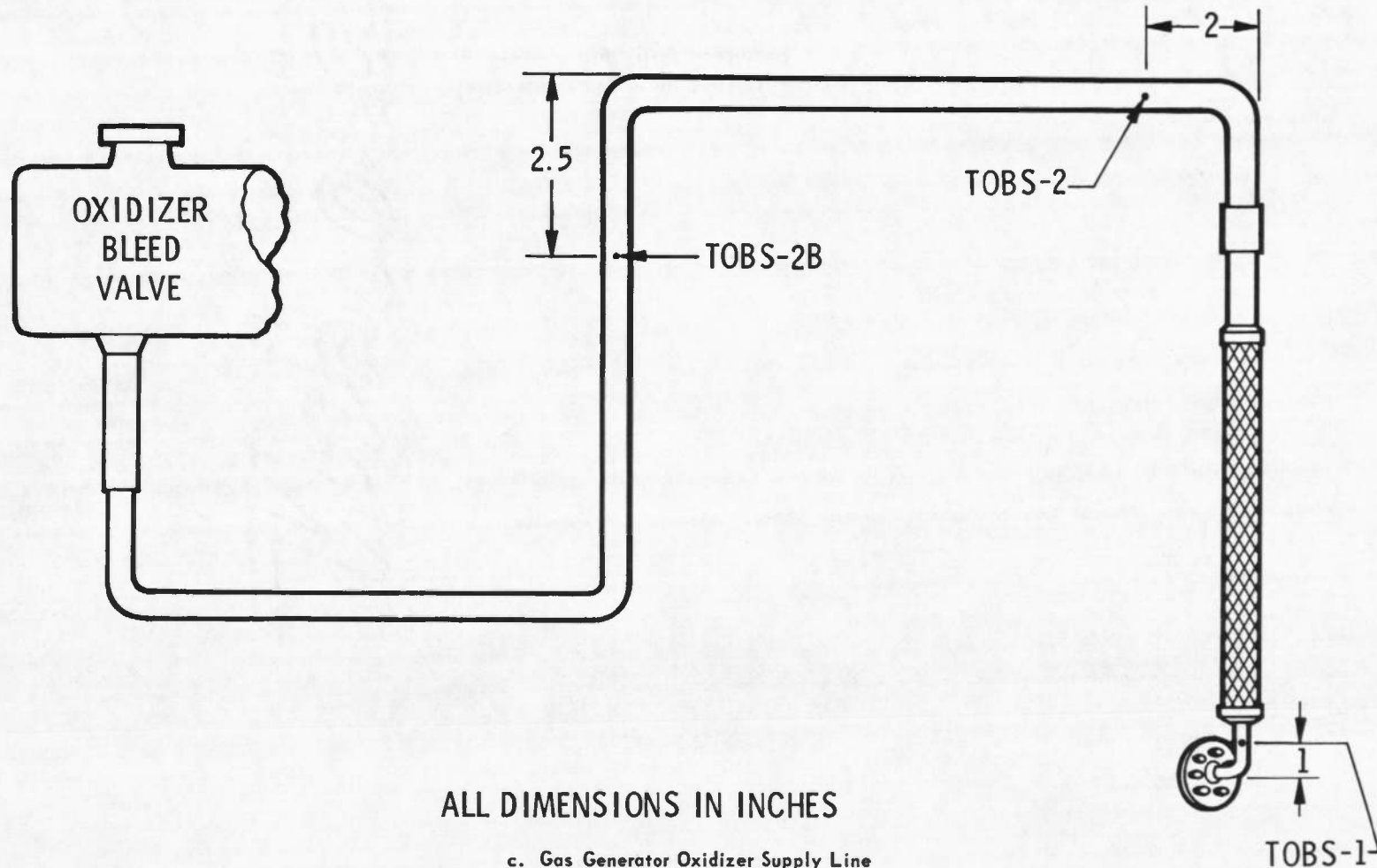

ALL DIMENSIONS IN INCHES

c. Gas Generator Oxidizer Supply Line
Fig. III-1 Continued

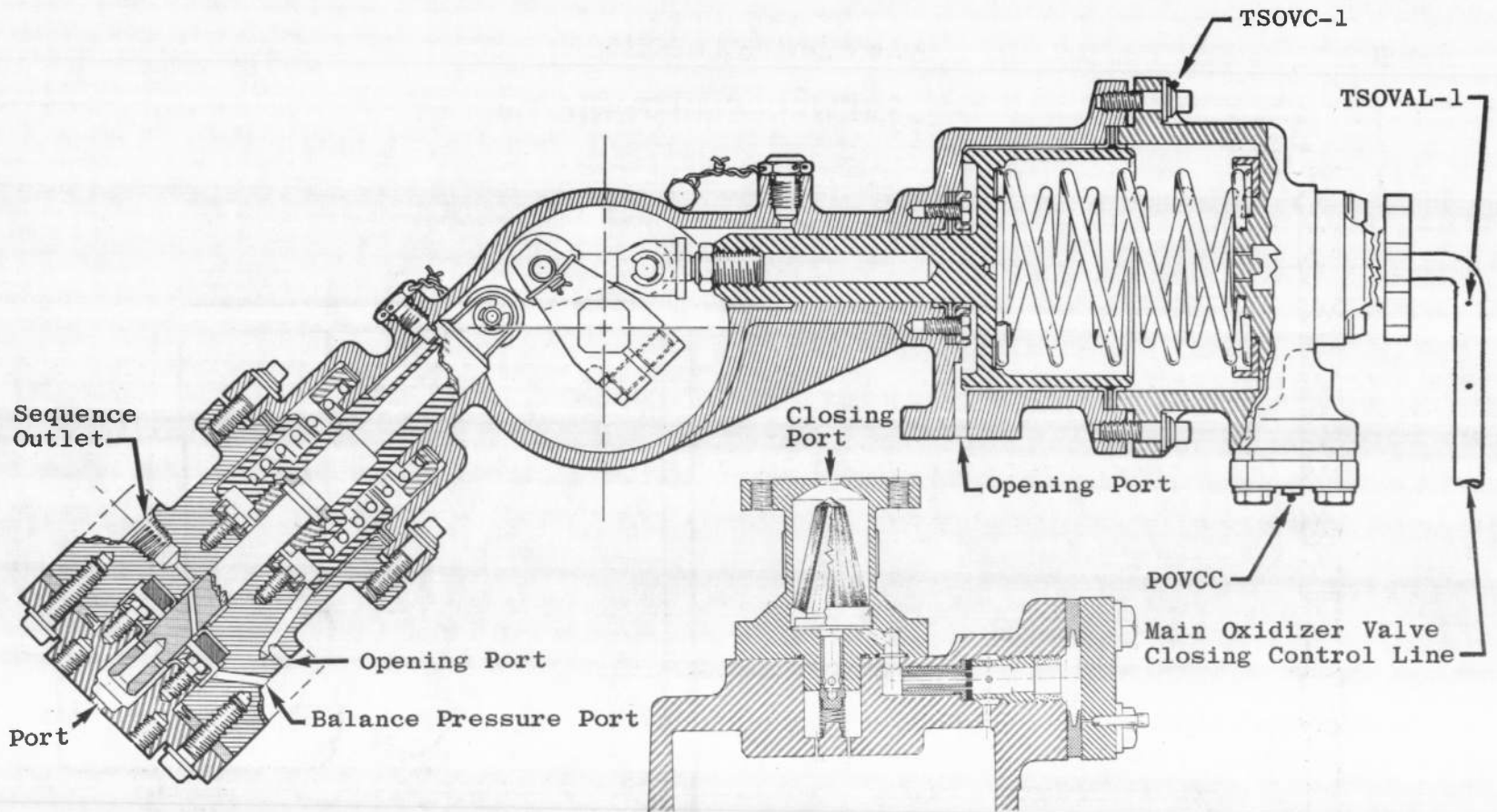

152

d. Main Oxidizer Valve
Fig. III-1 Continued

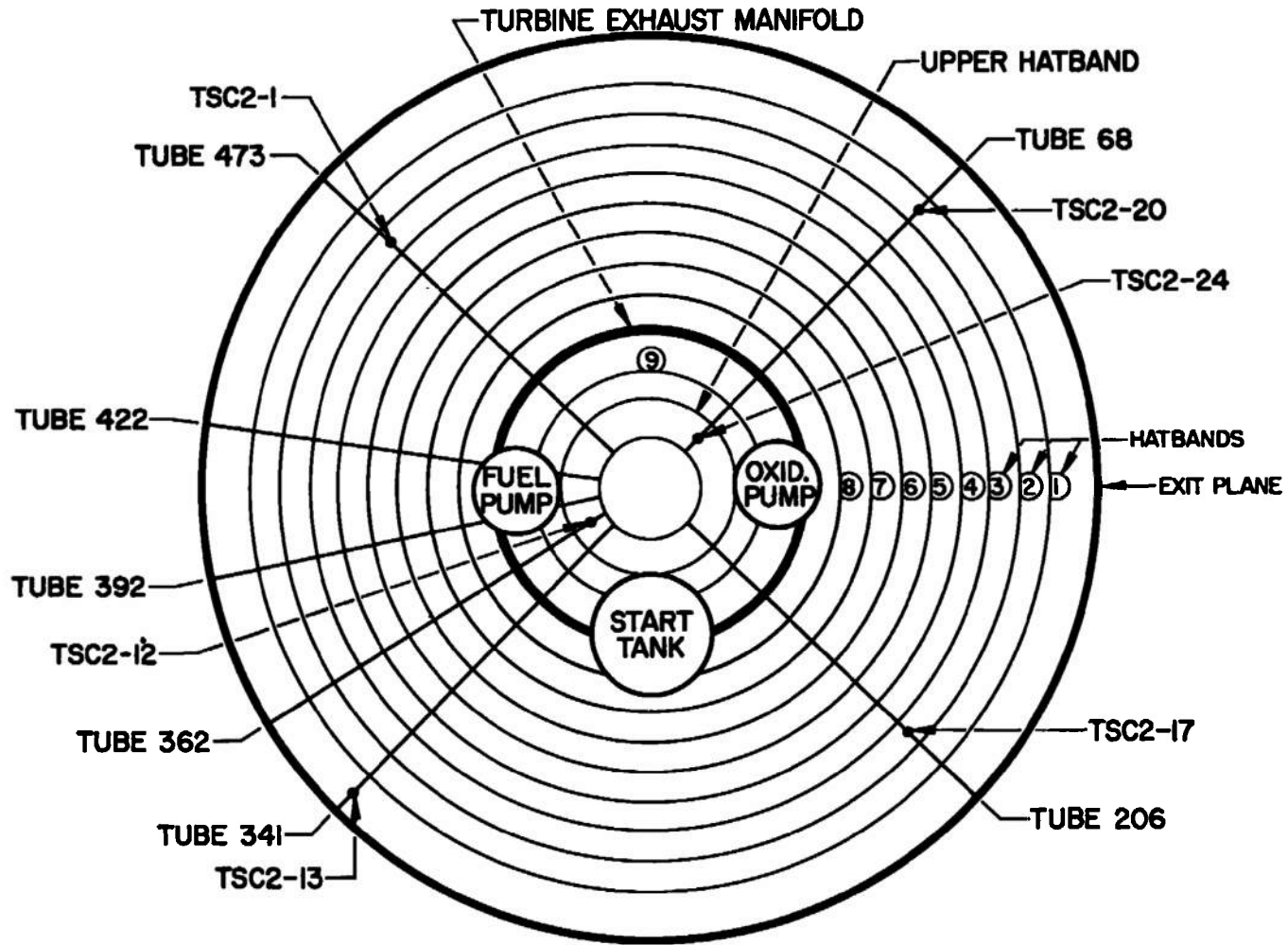

VIEW LOOKING AFT

e. Thrust Chamber
Fig. III-1 Concluded

**APPENDIX IV
METHODS OF CALCULATION (PERFORMANCE PROGRAM)**

**TABLE IV-1
PERFORMANCE PROGRAM DATA INPUTS**

Item No.	Parameter
1	Thrust Chamber (Injector Face) Pressure, psia
2	Thrust Chamber Fuel and Oxidizer Injection Pressures, psia
3	Thrust Chamber Fuel Injection Temperature, °F
4	Fuel and Oxidizer Flowmeter Speeds, Hz
5	Fuel and Oxidizer Engine Inlet Pressures, psia
6	Fuel and Oxidizer Pump Discharge Pressures, psia
7	Fuel and Oxidizer Engine Inlet Temperatures, °F
8	Fuel and Oxidizer (Main Valves) Temperatures, °F
9	Propellant Utilization Valve Center Tap Voltage, volts
10	Propellant Utilization Valve Position, volts
11	Fuel and Oxidizer Pump Speeds, rpm
12	Gas Generator Chamber Pressure, psia
13	Gas Generator (Bootstrap Line at Bleed Valve) Temperature, °F
14	Fuel* and Oxidizer Turbine Inlet Pressure, psia
15	Oxidizer Turbine Discharge Pressure, psia
16	Fuel and Oxidizer Turbine Inlet Temperature, °F
17	Oxidizer Turbine Discharge Temperature, °F

*At AEDC, fuel turbine inlet pressure is calculated from gas generator chamber pressure.

NOMENCLATURE

A	Area, in. ²
B	Horsepower
C	Coefficient
C*	Characteristic velocity, ft/sec
D	Diameter, in.
F	Thrust, lbf
H	Head, ft
h	Enthalpy, Btu/lb _m
I	Impulse
M	Molecular weight
N	Speed, rpm
P	Pressure, psia
Q	Flow rate, gpm
R	Resistance, sec ² /ft ³ -in. ²
r	Mixture ratio, O/F
T	Temperature, °F
TC*	Theoretical characteristic velocity, ft/sec
W	Weight flow, lb/sec
Z	Differential pressure, psi
β	Ratio
γ	Ratio of specific heats
η	Efficiencies
θ	Degrees
ρ	Density, lb/ft ³

SUBSCRIPTS

A	Ambient
AA	Ambient at thrust chamber exit
B	Bypass nozzle

BIR	Bypass nozzle inlet (Rankine)
BNI	Bypass nozzle inlet (total)
C	Thrust chamber
CF	Thrust chamber, fuel
CO	Thrust chamber, oxidizer
CV	Thrust chamber, vacuum
E	Engine
EF	Engine fuel
EM	Engine measured
EO	Engine oxidizer
EV	Engine, vacuum
e	Exit
em	Exit measured
F	Thrust
FIT	Fuel turbine inlet
FM	Fuel measured
FY	Thrust, vacuum
f	Fuel
G	Gas generator
GF	Gas generator fuel
GO	Gas generator oxidizer
H1	Hot gas duct No. 1
H1R	Hot gas duct No. 1 (Rankine)
H2R	Hot gas duct No. 2 (Rankine)
IF	Inlet fuel
IO	Inlet oxidizer
ITF	Isentropic turbine fuel
ITO	Isentropic turbine oxidizer
N	Nozzle
NB	Bypass nozzle (throat)

NV Nozzle, vacuum
O Oxidizer
OC Oxidizer pump calculated
OF Outlet fuel pump
OFIS Outlet fuel pump isentropic
OM Oxidizer measured
OO Oxidizer outlet
PF Pump fuel
PO Pump oxidizer
PUVO Propellant utilization valve oxidizer
RNC Ratio bypass nozzle, critical
SC Specific, thrust chamber
SCV Specific thrust chamber, vacuum
SE Specific, engine
SEV Specific, engine vacuum
T Total
TEF Turbine exit fuel
TEFS Turbine exit fuel (static)
TF Fuel turbine
TIF Turbine inlet fuel (total)
TIFM Turbine inlet, fuel, measured
TIFS Turbine inlet fuel isentropic
TIO Turbine inlet oxidizer
TO Turbine oxidizer
t Throat
V Vacuum
v Valve
XF Fuel tank repressurant
XO Oxidizer tank repressurant

PERFORMANCE PROGRAM EQUATIONS

THRUST

Thrust Chamber, Vacuum

$$F_{CV} = C (P_C)^2 + B (P_C) + A$$

Empirical Determination from Curve Fit of Thrust versus P_C

Thrust Chamber

$$F_C = F_{CV} - P_{AA} A_e$$

$$A_e = A_{em} + 12.8$$

 P_{AA} = Measured Cell Pressure

Engine, Vacuum

$$F_{EV} = F_{CV}$$

Engine

$$F_E = F_C$$

MIXTURE RATIO

Engine

$$r_E = \frac{W_{EO}}{W_{EF}}$$

$$W_{EO} = W_{OM} - W_{XO}$$

$$W_{EF} = W_{FM} - W_{XF}$$

Thrust Chamber

$$r_C = \frac{W_{CO}}{W_{CF}}$$

$$W_{CO} = W_{OM} - W_{XO} - W_{GO}$$

$$W_{CF} = W_{FM} - W_{XF} - W_{GF}$$

$$W_{XO} = \text{Standard } 0.9 \text{ lb/sec}$$

$$W_{XF} = \text{Standard } 2.1 \text{ lb/sec}$$

$$W_{GO} = W_T - W_{GF}$$

$$W_{GF} = \frac{W_T}{1 + r_G}$$

$$W_T = \frac{P_{TIF} A_{TIF} K_7}{TC * TIF}$$

$$K_7 = 32.174$$

Normalized engine and thrust chamber vacuum data calculated as measured, except all flows are normalized using standard inlet pressures, temperatures, and densities listed below:

$$P_{10} \text{ STD} = 39 \text{ psia}$$

$$P_{1F} \text{ STD} = 30 \text{ psia}$$

$$\rho_{10} \text{ STD} = 70.79 \text{ lb/ft}^3$$

$$\rho_{1F} \text{ STD} = 4.40 \text{ lb/ft}^3$$

$$T_{10} \text{ STD} = -295.2^\circ\text{F}$$

$$T_{1F} \text{ STD} = 422.5^\circ\text{F}$$

SPECIFIC IMPULSE

Engine

$$I_{SE} = \frac{F_E}{W_E}$$

$$W_E = W_{EO} + W_{EF}$$

Engine, Vacuum

$$I_{SEV} = \frac{F_{EV}}{W_{EV}}$$

$W_{EV} = W_E$ Normalized using standard inlet pressures, temperatures, and densities

Chamber

$$I_{SC} = \frac{F_C}{W_C}$$

$$W_C = W_{CO} + W_{CF}$$

Chamber, Vacuum

$$I_{SCV} = \frac{F_{CV}}{W_{CV}}$$

$W_{CV} = W_C$ Normalized using standard inlet pressures, temperatures, and densities

CHARACTERISTIC VELOCITY

Thrust Chamber

$$C^* = \frac{K_7 P_C A_t}{W_C}$$

$$K_7 = 32.174$$

Thrust Chamber, Vacuum

$$C^*_V = \frac{K_7 P_{CV} A_t}{W_{CV}}$$

$$K_7 = 32.174$$

Nozzle

$$C_N^* = \frac{C^*}{K_6}$$

$$K_6 = 1.086$$

Nozzle, Vacuum

$$C_{NV}^* = \frac{C_V^*}{K_6}$$

$$K_6 = 1.086$$

THRUST COEFFICIENT

Engine

$$C_F = \frac{F_C}{P_C A_t}$$

Engine, Vacuum

$$C_{FV} = \frac{F_{CV}}{P_C A_t}$$

DEVELOPED PUMP HEAD

Oxidizer

$$H_O = K_4 \left(\frac{P_{OO}}{\rho_{OO}} - \frac{P_{IO}}{\rho_{IO}} \right)$$

$$K_4 = 144$$

$$\rho = \text{National Bureau of Standards Values } f(P, T)$$

Fuel

$$H_F = 778.16 \Delta h_{OFIS}$$

$$\Delta h_{OFIS} = h_{OFIS} - h_{IF}$$

$$h_{OFIS} = f(P, T)$$

$$h_{IF} = f(P, T)$$

Fuel and Oxidizer Vacuum

Conditions normalized using standard inlet pressures, temperatures, and densities.

PUMP EFFICIENCIES

Fuel, Isentropic

$$\eta_F = \frac{h_{OFIS} - h_{IF}}{h_{OF} - h_{IF}}$$

$$h_{OF} = f(P_{OF}, T_{OF})$$

Oxidizer, Isentropic

$$\eta_0 = \eta_{0C} Y_0$$

$$\eta_{0C} = K_{40} \left(\frac{Q_{PO}}{N_0} \right)^2 + K_{50} \left(\frac{Q_{PO}}{N_0} \right) + K_{60}$$

$$Y_0 = 1.000$$

$$K_{40} = -5.053 \quad K_{50} = 3.861 \quad K_{60} = 0.0733$$

TURBINES

Oxidizer, Efficiency

$$\eta_{TO} = \frac{B_{TO}}{B_{ITO}}$$

$$B_{TO} = K_5 \frac{W_{PO} H_0}{\eta_0}$$

$$K_5 = 0.001818$$

$$W_{PO} = W_{OM} + W_{PUVO}$$

$$W_{PUVO} = \sqrt{\frac{Z_{PUVO} \rho_{OO}}{R_v}}$$

$$Z_{PUVO} = A + B (P_{OO})$$

$$A = -1597$$

$$B = 2.3828$$

$$\text{if } P_{OO} \geq 1010$$

$$\text{set } P_{OO} = 1010$$

$$\ln R_v = A + B (\theta_{PUVO}) + C(\theta_{PUVO})^3 + D \left(\frac{\theta_{PUVO}}{e} \right)^7 + E \theta_{PUVO} \left(\frac{\theta_{PUVO}}{e} \right)^7 + F \left[\left(\frac{\theta_{PUVO}}{e} \right)^7 \right]^2$$

$$A = 5.566 \times 10^{-1}$$

$$B = 1.500 \times 10^{-2}$$

$$C = 7.941 \times 10^{-6}$$

$$D = 1.234$$

$$E = -7.255 \times 10^{-2}$$

$$F = 5.069 \times 10^{-2}$$

Fuel, Efficiency

$$\eta_{TF} = \frac{B_{TF}}{B_{ITF}}$$

$$B_{ITF} = K_{10} \Delta h_F W_T$$

$$\Delta h_F = h_{TIF} - h_{TEF}$$

$$B_{TF} = B_{PF} = K_5 \left(\frac{W_{PF} H_F}{\eta_F} \right)$$

$$W_{PF} = W_{FM}$$

$$K_{10} = 1.415$$

$$K_5 = 0.001818$$

Oxidizer, Developed Horsepower

$$B_{TO} = B_{PO}$$

$$B_{PO} = K_5 \left(\frac{W_{PO} H_O}{\eta_O} \right)$$

$$K_5 = 0.001818$$

Fuel, Developed Horsepower

$$B_{TF} = B_{PF}$$

$$B_{PF} = K_5 \left(\frac{W_{PF} H_F}{\eta_F} \right)$$

$$W_{PF} = W_{FM}$$

Fuel, Weight Flow

$$W_{TF} = W_T$$

$$W_{TO} = W_T - W_B$$

$$W_B = \left[\frac{2K_7 \gamma_{H_2}}{\gamma_{H_2} - 1} \cdot (P_{RNC}) \frac{2}{\gamma_{H_2}} \right]^{\frac{1}{2}} \left[1 - (P_{RNC}) \frac{\gamma_{H_2} - 1}{\gamma_{H_2}} \right]^{\frac{1}{2}} \frac{A_{NB} P_{BNI}}{(R_{H_2} T_{BIR})^{\frac{1}{2}}}$$

$$P_{RNC} = f(\beta_{NB}, \gamma_{H_2})$$

$$\beta_{NB} = D_{NB}/D_B$$

$$\gamma_{H_2}, M_{H_2} = f(T_{H_2R}, r_G)$$

$$A_{NB} = K_{13} (D_{NB})^2$$

$$K_{13} = 0.7854$$

$$T_{BIR} = T_{TIO} + 460$$

$$P_{BNI} = P_{TEFS}$$

$$P_{TEFS} = \text{Iteration of } P_{TEF}$$

$$P_{TEF} = P_{TEFS} \left[1 + K_8 \left(\frac{W_T}{P_{TEFS}} \right)^2 \frac{T_{H2R}}{D_{TEF}^4 M_{H2}} \left(\frac{\gamma_{H2}-1}{\gamma_{H2}} \right) \right]^{\frac{\gamma_{H2}}{\gamma_{H2}-1}}$$

$$K_8 = 38.90$$

GAS GENERATOR

Mixture Ratio

$$r_G = D_1 (T_{H1})^3 + C_1 (T_{H1})^2 + B_1 (T_{H1}) + A_1$$

$$A_1 = 0.2575$$

$$B_1 = 5.586 \times 10^{-4}$$

$$C_1 = -5.332 \times 10^{-9}$$

$$D_1 = 1.1312 \times 10^{-11}$$

$$T_{H1} = T_{T1FM}$$

Flows

$$TC^*_{TIF} = D_2 (T_{H1})^3 + C_2 (T_{H1})^2 + B_2 (T_{H1}) + A_2$$

$$A_2 = 4.4226 \times 10^3$$

$$B_2 = 3.2267$$

$$C_2 = -1.3790 \times 10^{-3}$$

$$D_2 = 2.6212 \times 10^{-7}$$

$$P_{TIF} = P_{TIFS} \left[1 + K_8 \left(\frac{W_T}{P_{TIFS}} \right)^2 \frac{T_{H1R}}{D_{TIF}^4 M_{H1}} \frac{\gamma_{H1}-1}{\gamma_{H1}} \right]^{\frac{\gamma_{H1}}{\gamma_{H1}-1}}$$

$$K_8 = 38.8983$$

Note: P_{TIF} is determined by iteration.

$$T_{H1R} = T_{T1FM} + 460$$

$$M_{H1}, \gamma_{H1}, C_p, r_{H1} = f(T_{H1R}, r_G)$$

DOCUMENT CONTROL DATA - R & D

(Security classification of title, body of abstract and indexing annotation must be entered when the overall report is classified)

1. ORIGINATING ACTIVITY (Corporate author) Arnold Engineering Development Center ARO, Inc., Operating Contractor Arnold Air Force Station, Tennessee	2a. REPORT SECURITY CLASSIFICATION UNCLASSIFIED 2b. GROUP N/A
---	---

3. REPORT TITLE
FLIGHT SUPPORT TESTING OF THE J-2 ROCKET ENGINE IN PROPULSION ENGINE TEST CELL (J-4) (TESTS J4-1901-09 THROUGH J4-1901-11)

4. DESCRIPTIVE NOTES (Type of report and inclusive dates)
September 4 and 24, 1968 - Interim Report

5. AUTHOR(S) (First name, middle initial, last name)
H. J. Counts, Jr., ARO, Inc.

6. REPORT DATE January 1969	7a. TOTAL NO OF PAGES 172	7b. NO OF REFS 4
---------------------------------------	-------------------------------------	----------------------------

8a. CONTRACT OR GRANT NO. F40600-69-C-0001 b. PROJECT NO. 9194 c. System 921E d.	9a. ORIGINATOR'S REPORT NUMBER(S) AEDC-TR-68-272 9b. OTHER REPORT NO(S) (Any other numbers that may be assigned this report) N/A
--	---

10. DISTRIBUTION STATEMENT
 Each transmittal of this document outside the Department of Defense must have prior approval of NASA, Marshall Space Flight Center (I-E-J), Huntsville, Alabama 35812.

11. SUPPLEMENTARY NOTES Available in DDC.	12. SPONSORING MILITARY ACTIVITY NASA, Marshall Space Flight Center (I-E-J), Huntsville, Alabama 35812
---	--

13. ABSTRACT

Fourteen firings of the Rocketdyne J-2 rocket engine were conducted during test periods J4-1901-09, 10, and 11 between September 4 and 24, 1968, in Test Cell (J-4) of the Large Rocket Facility. The firings were accomplished at pressure altitudes ranging from 81,000 to 107,000 ft at engine start. Basic test objectives were to evaluate the effect on the engine start transient of (1) different configuration gas generator oxidizer supply lines, (2) gaseous helium as a start tank pressurant, (3) start tank pressures ranging from 600 to 1000 psia, and (4) a simulated gas generator fuel poppet leak. Engine components were thermally conditioned to temperatures representative of S-IVB engine/interstage environment for a first burn, 80-min restart, or 6-hr restart. The total accumulated firing duration for the three test periods was 181.6 sec.

This document is subject to special export controls and each transmittal to foreign governments or foreign nationals may be made only with prior approval of NASA, Marshall Space Flight Center (I-E-J), Huntsville, Alabama 35812.

This document has been approved for public release and its distribution is unlimited.

Letter dated 12 Feb 74 signed William D. Cole

