

UNCLASSIFIED

AD NUMBER

AD848636

LIMITATION CHANGES

TO:

Approved for public release; distribution is unlimited.

FROM:

Distribution authorized to U.S. Gov't. agencies and their contractors;
Administrative/Operational Use; NOV 1968. Other requests shall be referred to Army Aviation Materiel Labs., Fort Eustis, VA.

AUTHORITY

USAAVLABS ltr 23 Jun 1971

THIS PAGE IS UNCLASSIFIED

AD848636

AD

USAAVLABS TECHNICAL REPORT 68-78
RELATIVE VULNERABILITY AND
COST-EFFECTIVENESS STUDY OF
TRANSMISSION OIL HEAT REJECTION SYSTEMS

By

A. J. Lemanski

H. J. Rose

D D C
RECEIVED
MAR 6 1969
REGULATED
B

November 1968

U. S. ARMY AVIATION MATERIEL LABORATORIES
FORT EUSTIS, VIRGINIA

CONTRACT DAAJ02-67-C-0112
THE BOEING COMPANY
VERTOL DIVISION
PHILADELPHIA, PENNSYLVANIA

This document is subject to special export controls and each transmittal to foreign governments or foreign nationals may be made only with prior approval of US Army Aviation Materiel Laboratories, Fort Eustis, Virginia 23604.



Disclaimers

The findings in this report are not to be construed as an official Department of the Army position unless so designated by other authorized documents.

When Government drawings, specifications, or other data are used for any purpose other than in connection with a definitely related Government procurement operation, the United States Government thereby incurs no responsibility nor any obligation whatsoever; and the fact that the Government may have formulated, furnished, or in any way supplied the said drawings, specifications, or other data is not to be regarded by implication or otherwise as in any manner licensing the holder or any other person or corporation, or conveying any rights or permission, to manufacture, use, or sell any patented invention that may in any way be related thereto.

Trade names cited in this report do not constitute an official endorsement or approval of the use of such commercial hardware or software.

Disposition Instructions

Destroy this report when no longer needed. Do not return it to originator.

ATTN	WRITE SECTION	<input type="checkbox"/>
	DIFF SECTION	<input checked="" type="checkbox"/>
ANNOUNCED		<input type="checkbox"/>
DISTRIBUTION/AVAILABILITY CODES		
DISC.	AVAIL.	HOW/IF OBTAINABLE
2		



DEPARTMENT OF THE ARMY
HEADQUARTERS US ARMY AVIATION MATERIEL LABORATORIES
FORT EUSTIS, VIRGINIA 23604

This report presents the results of a program to investigate various helicopter transmission cooling system concepts having considerably less vulnerability than currently utilized systems. The results reported herein indicate that a cooling system which is integral with the transmission significantly reduces vulnerability without penalty in overall system performance.

The findings of this study further indicate that an integral transmission lubrication and cooling system should be incorporated in the initial design of future military helicopters.

This command generally concurs in the findings of this report.

Task 1G121401D14414
Contract DAAJ02-67-C-0112
USAAVLABS Technical Report 68-78
November 1968

RELATIVE VULNERABILITY AND
COST-EFFECTIVENESS STUDY OF
TRANSMISSION OIL HEAT REJECTION SYSTEMS

D8-0927

By

A. J. Lemanski
and
H. J. Rose

Prepared by

THE BOEING COMPANY
VERTOL DIVISION
Philadelphia, Pennsylvania

for

U.S. ARMY AVIATION MATERIEL LABORATORIES
FORT EUSTIS, VIRGINIA

This document is subject to special export controls and each transmittal to foreign governments or foreign nationals may be made only with prior approval of US Army Aviation Materiel Laboratories, Fort Eustis, Virginia 23604.

SUMMARY

This program comprised the study of nine different methods, using the current state of the art, for dissipating the heat rejected into the oil in the forward transmission of a CH-47 helicopter. Five fluid heat transport systems and four dynamic heat pump and refrigeration systems were studied. In every case, the system under study was compared with the present production CH-47 oil-cooling system, which was used as a baseline for purposes of comparison.

The objective of this program was to determine which of the nine methods would be the most suitable for cooling the forward transmission and for reducing the vulnerability of the system by a substantial amount, while at the same time obtaining a cost-effective system compatible with helicopter requirements.

All of the methods studied were optimized for the CH-47 helicopter and were evaluated on the basis of vulnerability, weight (including horsepower penalty), reliability, maintainability, and cost. The evaluation provided a cost-effective value for each system studied.

The results of this study indicate that the compact oil-to-air and oil-to-liquid-to-air systems are the most suitable for the CH-47 forward rotor transmission. With the addition of integral armor, the vulnerability would be reduced further, and the cost effectiveness would be increased substantially.

FOREWORD

This final technical report concludes the study of various methods for helicopter main transmission oil heat rejection conducted by the Vertol Division of The Boeing Company under U.S. Army Contract DAAJ02-67-C-0112. The program was initiated on 11 July 1967.

The authors acknowledge the contributions of the Harrison Radiator Division of General Motors Corporation, Lockport, New York.

BLANK PAGE

TABLE OF CONTENTS

	<u>Page</u>
SUMMARY	iii
FOREWORD	v
LIST OF ILLUSTRATIONS	ix
LIST OF TABLES	x
LIST OF SYMBOLS	xi
INTRODUCTION	1
TECHNICAL APPROACH	3
COOLING SYSTEM DESIGN CRITERIA	5
OIL-COOLER DESIGN CONDITIONS	5
OIL FOAM HEAT TRANSFER PROPERTIES	5
OIL FOAM TRANSPORT PROPERTIES	8
SYSTEM DESCRIPTION	9
INTEGRAL OIL-AIR SYSTEM	9
CLOSE-COUPLED OIL-AIR SYSTEM	9
OIL-WATER/GLYCOL-AIR SYSTEM	9
OIL-BOILING REFRIGERANT-AIR SYSTEM	9
AIR CYCLE-HEAT PUMP SYSTEM	10
CH-47 PRODUCTION OIL-AIR SYSTEM	10
HEAT PIPE SYSTEM	10
VAPOR CYCLE SYSTEM	10
AIR CYCLE-AIR COOLING SYSTEM	11
ABSORPTION SYSTEM	11
SYSTEM CHARACTERISTICS	34
SYSTEM ANALYSIS METHOD	37
VULNERABILITY EVALUATION	37
VULNERABILITY RATING	38
MISSION WEIGHT DETERMINATION	41
EQUIVALENT WEIGHT RATING	41
RELIABILITY RATING	42
MAINTAINABILITY RATING	42
COST RATING	46
TOTAL SYSTEM RATING	46

	<u>Page</u>
DESIGN CONSIDERATIONS	50
OIL COOLER VOLUME	50
SYSTEM INSTALLED WEIGHT	50
SYSTEM POWER AND EQUIVALENT WEIGHT	50
SYSTEM VOLUME	50
SYSTEM RELIABILITY	50
SYSTEM MAINTAINABILITY	51
SYSTEM COST	51
COST-EFFECTIVENESS VALUE	51
DEVELOPMENT PROBLEMS	52
INTEGRAL OIL-AIR SYSTEM	52
CLOSE-COUPLED OIL-AIR SYSTEM	52
OIL-WATER/GLYCOL-AIR SYSTEM	52
OIL-BOILING REFRIGERANT-AIR SYSTEM	52
AIR CYCLE-HEAT PUMP SYSTEM	52
CH-47 PRODUCTION SYSTEM	53
HEAT PIPE SYSTEM	52
VAPOR CYCLE SYSTEM	53
AIR CYCLE-AIR COOLING SYSTEM	53
ABSORPTION SYSTEM	54
DETAILED PRELIMINARY SYSTEM LAYOUTS	55
RESULTS AND DISCUSSION	75
INTEGRAL OIL-AIR SYSTEM	75
CLOSE-COUPLED OIL-AIR SYSTEM	75
OIL-WATER/GLYCOL-AIR SYSTEM	75
OIL-BOILING REFRIGERANT-AIR SYSTEM	76
AIR CYCLE-HEAT PUMP SYSTEM	76
HEAT PIPE SYSTEM	76
VAPOR CYCLE SYSTEM	76
AIR CYCLE-AIR COOLING SYSTEM	77
ABSORPTION SYSTEM	77
CONCLUSIONS	78
SELECTED BIBLIOGRAPHY	79
APPENDIX. Detailed Heat Transfer Calculations for the Integral Oil-Air System	80
DISTRIBUTION	87

LIST OF ILLUSTRATIONS

<u>Figure</u>		<u>Page</u>
1	Integral Oil-Air System	13
2	Close-Coupled Oil-Air System	15
3	Oil-Water/ glycol-Air System	17
4	Oil-Boiling Refrigerant-Air System	19
5	Air Cycle-Heat Pump System	21
6	CH-47 Production System	23
7	Heat Pipe System	25
8	Vapor Cycle System	27
9	Air Cycle-Air Cooling System	29
10	Absorption System	31
11	Absorption System Operational Cycle	33
12	Vulnerability Rating	40
13	Equivalent Weight Rating	40
14	Reliability Rating	44
15	Maintainability Rating	44
16	Cost Rating	48
17	Total System Rating	48
18	Centerline Section of Integrally Cooled Transmission	57
19	Integral Oil-Air System Layout	59
20	Integral Oil-Air System	61
21	Close-Coupled Oil-Air System Layout	63
22	Close-Coupled Oil-Air System	65
23	Oil-Water/Glycol-Air System Layout	67

<u>Figure</u>		<u>Page</u>
24	Oil-Water/Glycol-Air System	69
25	Oil-Boiling Refrigerant-Air System Layout	71
26	Oil-Boiling Refrigerant-Air System	73
27	Integral Oil-Air System Oil Cooler	81
28	Heat Exchanger Effectiveness	84
29	Blower Performance	86

LIST OF TABLES

<u>Table</u>		<u>Page</u>
I	Summary of Oil-Air Foam Properties Through Oil Cooler	6
II	Summary of System Physical Characteristics	35
III	Summary of System Cost, Reliability, and Maintainability Characteristics	36
IV	CH-47 Production System Reliability Rating	43
V	Close-Coupled Oil-Air System Reliability Rating	43
VI	CH-47 Production System Maintainability Rating	45
VII	Close-Coupled Oil-Air System Maintainability Rating	45
VIII	CH-47 Production System Cost Rating	47
IX	Close-Coupled Oil-Air System Cost Rating	47
X	Dollar Summary of System Cost-Effectiveness Ratings	49
XI	Ranges of Cost-Effectiveness Value	51

LIST OF SYMBOLS

A_D	direct heat transfer surface, ft^2
A_E	effective heat transfer surface, $A_D + E_f A_I$, ft^2
A_I	indirect heat transfer surface, ft^2
Btu	British thermal units
C_p	specific heat, $\text{Btu}/\text{lb}-^\circ\text{F}$
D_h	hydraulic diameter, ft
E_f	fin efficiency, percent
equivalent weight	(horsepower x 7 lb/hp) + hardware weight
FARADA	Failure Rate Data Handbcok ¹
f	friction coefficient
ft^3	cubic feet
G	mass flow rate, $\text{lb}/\text{hr}-\text{ft}^2$
h	surface conductance, $\text{Btu}/\text{hr}-\text{ft}^2-^\circ\text{F}$
hp	horsepower
hr	hours
in.^3	cubic inches
k	thermal conductivity, $\text{Btu}/\text{hr}-\text{ft}-^\circ\text{F}$
lb	pounds
min	minutes
NTU_{MAX}	number of heat transfer units, UA/C , lb/hr
P_r	Prandtl number, $C_p \mu/k$
P_s	static pressure, lb/in^2
psia	pounds per square inch absolute
P_T	total pressure, $P_V + P_S$, lb/in^2

P_v	dynamic pressure, lb/in^2
Q	heat load, Btu/min
R_e	Reynolds number, nondimensional
Refrigerant-11	standard commercially produced refrigerant, sold under various proprietary trade names
R_g	local area fraction of gas phase; i.e., the fraction of the tube cross section occupied by the gas phase (air)
rpm	revolutions per minute
UA	overall conductance, $\frac{1}{\frac{1}{hA_E} + \frac{1}{hA_E}}$, $\text{Btu/hr-}^\circ\text{F}$ (OIL) (AIR)
V	specific volume, ft^3/lb
W	flow rate, lb/min
WC	heat capacity flow rate, $\text{Btu/hr-}^\circ\text{F}$
WC_p	heat capacity flow rate, $\text{Btu/hr-}^\circ\text{F}$
X	weight fraction of the entrained air
ΔP	differential pressure, lb/in^2
ΔT	temperature difference, $^\circ\text{F}$
ϵ	heat exchanger effectiveness, percent
μ	viscosity, lb/ft-hr
ρ	density, lb/ft^3
$^\circ\text{F}$	degrees Fahrenheit
$\%$	percent
\therefore	therefore

INTRODUCTION

Operation of the CH-47 helicopter in the combat environment of Southeast Asia has revealed several problem areas. One such area is the forward transmission oil cooling system. Due to the oil cooler's remote location and long oil lines, this system is vulnerable to oil loss as a result of combat hits.

Complete loss of oil from the forward transmission due to a .30- or .50-caliber hit in the cooling system will occur in approximately 20 to 30 seconds. Because of the high heat rejection rate and the large loads carried by the transmission, complete loss of oil is considered to be an A-kill,¹ while total cooling loss with no oil loss is considered to be a B-kill.² These classifications were applied to all the systems studied in this report in order to provide a well-defined kill classification for a component or system. An additional ground rule which was established for this study is that any oil cooler which can be located completely within an oil sump is considered to be invulnerable to combat damage because of recent advances in lightweight (dualized) armor-plate manufacturing technology with respect to oil sump fabrication.

The susceptibility to combat damage of the present CH-47 forward transmission oil cooling system is greater than that for the other transmissions in the aircraft due to the vulnerability of the long oil lines and the remote location of the oil cooler from the transmission.

This study analyzes nine current state-of-the-art methods of transmission cooling suitable for aircraft application; various expendable-type systems were excluded from the study. The expendable systems are those systems which boil off a liquid such as water, ammonia, or cryogenic compounds. These systems were not considered because of their almost exclusive use for limited-time-period cooling, low heat rejection rates, weight penalty, and logistics and maintenance problems.

The approach taken in this study is based on two cooling methods. One method attempts to devise a system to operate within the temperature limits imposed by the oil temperature and atmospheric temperature. To achieve this objective, the following heat transport systems were studied:

¹ A-kill - Loss of control of the aircraft within 5 minutes

² B-kill - Loss of control of the aircraft within 30 minutes

1. Integral oil-air
2. Close-coupled oil-air
3. Oil-water/glycol-air
4. Oil-boiling refrigerant-air
5. Heat pipe

The second method employs dynamic heat pump and refrigeration systems to broaden the temperature difference between the oil and the heat rejection sink. To accomplish this objective, increased power is required because heat is raised to a higher reference level. The following dynamic systems were studied:

1. Air cycle-heat pump
2. Vapor cycle
3. Air cycle-air cooling
4. Absorption

Each system studied was evaluated with respect to the following factors:

1. A- and B-kill component volume
2. Vulnerability
3. System weight
4. Power consumption (1 horsepower = 7 pounds)
5. Equivalent weight
6. Reliability
7. Maintainability
8. Cost

During the conceptual design phase, it became apparent that certain systems were not feasible for helicopter application due to the high power consumption and the associated weight penalties. Therefore, the following systems were not refined beyond the concept design stage:

1. Vapor cycle
2. Air cycle-air cooling
3. Absorption

TECHNICAL APPROACH

To establish a cost-effectiveness rating for the nine concepts studied, the cooling systems had to meet all the requirements of the present CH-47 production system. This was accomplished by using actual performance characteristics for the forward transmission. The conditions requiring maximum oil cooling occur during an out-of-ground-effect hover at sea level on a 125°F day, at maximum permissible gross weight, and with the most forward allowable center of gravity. These conditions are defined in the section on Cooling System Design Criteria and have been standardized throughout this report.

The preliminary design of each system was executed in accordance with standard Boeing-Vertol practices. An analysis was performed to ascertain those systems wherein further development would have had little effect on their final ratings.

The systems which appeared to be the least cost-effective after completion of the concept design and analysis were as follows:

1. Vapor cycle
2. Air cycle-air cooling
3. Absorption

With further refinement, it was evident that the heat pipe system, although promising for the lower (50% or greater) heat loads encountered in aerospace applications, was not a competitive system for the high heat rejection rates encountered in helicopter transmission systems.

The remaining five systems were studied and optimized to obtain the most desirable configurations with the lowest overall cost-effectiveness ratings, while remaining within the CH-47 airframe space restrictions. These systems were the following:

1. Integral oil-air
2. Close-coupled oil-air
3. Oil-water/glycol-air
4. Oil-boiling refrigerant-air
5. Air cycle-heat pump

In order to optimize the air cycle-heat pump system, it is necessary to approach a pressure ratio of unity. Under these conditions, the heat pump system ceases to exist because the turbine expander and compressor sections act as blowers. Therefore, the air cycle-heat pump system would become an integral oil-air system.

The oil-water/glycol-air system appears to be superior to the oil-boiling refrigerant-air system because of its simplified design; i.e., no refrigerant pump with complicated seals and no logistics problems with a secondary fluid.

Final analysis of the nine systems under investigation indicates that the following three systems show the greatest possibility for further development:

1. Integral oil-air
2. Close-coupled oil-air
3. Oil-water/glycol-air

COOLING SYSTEM DESIGN CRITERIA

The CH-47 forward transmission has demonstrated an operating efficiency of 98.55 percent during test stand runs. The total drive system horsepower on the CH-47C aircraft is 6,000, with a maximum anticipated load, under the most adverse conditions, where 60 percent of the available power is used on the forward transmission. Due to the design and mechanical construction of the forward transmission oil circulation system, air becomes entrained in the oil mixture; this fact must be taken into consideration when designing the oil cooling system. Therefore, the heat rejection rate and the oil foam properties under the most adverse conditions are as follows:

Transmission horsepower = 60% of 6,000 hp = 3,600 hp

Transmission loss = 100% - 98.55% = 1.45%

Transmission horsepower

loss = 1.45% of 3,600 hp = 52.2 hp

Transmission heat

rejection rate = 52.2 hp x $\frac{42.4 \text{ Ptu/min}}{\text{hp}}$ = 2,200 Btu/min

OIL-COOLER DESIGN CONDITIONS

Cooling fluid: MIL-L-7808 + air = oil foam

Oil foam out of transmission: 235°F, 125 psia

Oil foam into transmission: 190°F, 75 psia

Oil foam volumetric flow rate: 3.64 ft³/min

Heat rejection rate: 2,200 Btu/min

Oil foam properties per Table I

OIL FOAM HEAT TRANSFER PROPERTIES

The oil foam heat transfer property calculations will be shown for the mean heat exchanger conditions (212.5°F, 100 psia); however, the inlet and outlet properties will be as shown in Table I.

$$Q = WC_p \Delta T$$

$$W_{\text{mix}} C_{p_{\text{mix}}} = \frac{Q}{\Delta T} = \frac{2,200 \text{ Btu/min}}{(235^\circ\text{F} - 190^\circ\text{F})} = 48.89 \text{ Btu/min-}^\circ\text{F} \quad (1)$$

$$C_{p_{\text{mix}}} = C_{p_{\text{air}}} \cdot X + C_{p_{\text{oil}}} \cdot (1-X) \quad (2)$$

where X = weight fraction of the entrained air.

TABLE I. SUMMARY OF OIL-AIR FOAM PROPERTIES THROUGH OIL COOLER

Property	Air		Oil		Oil Foam	
	Out	In	Out	In	Out	In
Temperature, °F	190	212.5	190	212.5	190	212.5
Pressure, psia	75	100	75	100	75	100
C _p - specific heat, Btu/lb-°F	0.2430	0.2435	0.488	0.501	0.487	0.499
V - specific volume, ft ³ /lb	3.210	2.489	0.0184	0.0186	0.0363	0.0371
Density, lb/ft ³	0.312	0.402	54.3	53.7	27.55	26.95
W - flow rate, lb/min	0.56	0.74	99.74	97.36	100.3	98.1
μ - viscosity, lb/ft-hr	0.0516	0.0529	11.58	9.57	5.87	4.78
k - thermal conductivity, Btu/hr-ft-°F	0.0178	0.0184	0.0846	0.0841	0.052	0.051
P _r - Prandtl number, C _p μ/k	-	-	-	-	54.97	46.77
P _r 2/3	-	-	-	-	14.47	13.00
						11.42

The total weight flow rate is related to the volumetric rate by

$$W_{\text{mix}} = \frac{\text{volumetric flow rate}}{V_{\text{mix}}}, \quad (3)$$

$$W_{\text{mix}} = \frac{3.64 \text{ ft}^3 / \text{min}}{V_{\text{mix}} \text{ ft}^3 / \text{lb}} = \frac{3.64 \text{ lb/min}}{V_{\text{mix}}}$$

where V = specific volume, ft^3/lb .

Assuming that the oil foam is a homogeneous mixture in which both phases are flowing at the same velocity; i.e., no slip, the specific volume is expressed as

$$V_{\text{mix}} = V_{\text{air}} \cdot X + V_{\text{oil}} \cdot (1-X). \quad (4)$$

Now, substituting equations (2), (3), and (4) into (1) and solving for the weight fraction of air, X , yields:

$$W_{\text{mix}} C_{P_{\text{mix}}} = 48.89 \text{ Btu/min-}^\circ\text{F}$$

$$\frac{3.64}{V_{\text{mix}}} \cdot C_{P_{\text{mix}}} = 48.89$$

$$C_{P_{\text{mix}}} = 13.43 V_{\text{mix}}$$

$$C_{P_{\text{mix}}} = 0.2435 X + 0.501 (1-X) = 0.501 - 0.2575 X$$

$$V_{\text{mix}} = 2.489 X + 0.0186 (1-X) = 2.470 X + 0.0186$$

$$(0.51 - 0.2575 X) = 13.43 (2.470 X + 0.0186)$$

$$\underline{X = 0.0075}$$

$$V_{\text{mix}} = 2.470 (0.0075) + 0.0186 = 0.0371 \text{ ft}^3/\text{lb}$$

$$C_{P_{\text{mix}}} = 0.501 - 0.2575 (0.0075) = 0.499 \text{ Btu/lb-}^\circ\text{F}$$

$$\text{Density}_{\text{mix}} = \frac{1}{V_{\text{mix}}} = \frac{1}{0.0371} = 26.95 \text{ lb/ft}^3$$

$$W_{\text{mix}} = \frac{3.64 \text{ lb/min}}{V_{\text{mix}}} = \frac{3.64}{0.0371} = 98.1 \text{ lb/min}$$

OIL FOAM TRANSPORT PROPERTIES

The oil foam transport property calculations will be shown for the mean heat exchanger conditions (212.5°F, 100 psia); however, the inlet and outlet properties will be as shown in Table I.

In evaluating oil foam viscosity and thermal conductivity, the component properties are weighted on the fraction of flow cross-sectional area occupied by each phase. Therefore,

$$\mu_{\text{mix}} = \mu_{\text{air}} R_g + \mu_{\text{oil}} (1-R_g),$$

$$k_{\text{mix}} = k_{\text{air}} R_g + k_{\text{oil}} (1-R_g),$$

where μ = viscosity, lb/ft-hr

k = thermal conductivity, Btu/hr-ft-°F

R_g = local area fraction of gas phase; i.e., the fraction of the tube cross section occupied by the gas phase (air).

One cubic foot of oil foam weighs 26.95 pounds.

Weight of air in 1 ft³ of foam = 0.0075 x 26.95 = 0.2021 lb

0.2021 lb of air occupies 0.2021 lb x 2.489 ft³/lb = 0.503 ft³

$$\therefore R_g = 0.503 \text{ ft}^3 \text{ air/ft}^3 \text{ mix}$$

At the mean heat exchanger conditions (212.5°F, 100 psia),

$$\mu_{\text{oil}} = 9.57 \text{ lb/ft-hr}$$

$$\mu_{\text{air}} = 0.0529 \text{ lb/ft-hr}$$

$$k_{\text{oil}} = 0.0841 \text{ Btu/hr-ft-}^\circ\text{F}$$

$$k_{\text{air}} = 0.0184 \text{ Btu/hr-ft-}^\circ\text{F.}$$

Therefore,

$$\mu_{\text{mix}} = 0.0529 (0.503) + 9.57 (1-0.503) = 4.78 \text{ lb/ft-hr,}$$

$$k_{\text{mix}} = 0.0184 (0.503) + 0.0841 (1-0.503) = 0.051 \text{ Btu/hr-ft-}^\circ\text{F.}$$

Table I shows the heat transfer and transport properties of the oil foam for the various conditions.

SYSTEM DESCRIPTION

This section describes each of the nine cooling systems that were investigated, identifies the key individual components of each system, and presents their method of operation. A description of the present production transmission oil cooling system for the CH-47 helicopter is also provided.

INTEGRAL OIL-AIR SYSTEM

The integral oil-air system (Figure 1) is composed of an annular, 2-pass, crossflow heat exchanger mounted directly on the bottom of the forward transmission. Cooling air is directed through the outside diameter of the cooler core and is discharged into the inside diameter, where a blower forces the hot air overboard through a duct. The hot oil from the filter enters the oil cooler, is cooled, and returns to the transmission oil jets.

CLOSE-COUPLED OIL-AIR SYSTEM

This system (Figure 2) employs a 3-pass, crossflow oil cooler mounted within the forward pylon, immediately aft of the forward transmission. Air enters the inlet air screen in the forward pylon, flows around the forward transmission, and into a blower, which is belt-driven from the synchronizing shaft. After discharge from the blower, the air travels into a transition duct where it is directed through the oil cooler core and ducted overboard. Hot oil from the filter travels through an oil line to the cooler, where it is cooled; the oil then returns through a second line to the transmission oil jets.

OIL-WATER/GLYCOL-AIR SYSTEM

The oil-water/glycol-air system (Figure 3) employs a liquid-to-liquid heat exchanger, completely enclosed by the oil sump, which transfers the heat from the oil to a water/glycol solution; this solution is then piped through lines to an air-water/glycol cooler located in approximately the same position as the oil-air cooler in the close-coupled oil-air system. In this system the oil does not leave the transmission.

OIL-BOILING REFRIGERANT-AIR SYSTEM

This system (Figure 4) operates on the same principle as the oil-water/glycol-air system except that Refrigerant-11 is used as the secondary cooling medium. The refrigerant passes through the oil cooler, where it is vaporized; it then flows to the condenser where the waste heat is rejected

to the atmosphere. The condensed liquid then returns to the oil cooler. The flow around the loop is maintained by a combination of natural convection and a gerotor pump.

AIR CYCLE-HEAT PUMP SYSTEM

The air cycle-heat pump system (Figure 5) is similar in its basic arrangement to the integral oil-air system; however, the heat pump system employs a turbine rather than a blower to circulate the air. The turbine expands the incoming air to reduce its temperature and to afford a larger allowable air temperature drop. The cool air is then directed through an oil-air cooler which removes the heat from the oil. The air is then compressed to atmospheric pressure by the compressor section of the turbine and is dumped overboard through an exhaust duct. The entire assembly is contained completely within the oil sump by shrouds which direct the airflow.

CH-47 PRODUCTION OIL-AIR SYSTEM

The CH-47 system (Figure 6) now in use transports the hot oil from the transmission by piping it approximately 39 feet to an oil-air cooler in the aft pylon. This oil cooler and three other coolers in a common housing operate from a single blower. After the oil is cooled, it returns through a second 39-foot length of tubing to the forward transmission oil jets.

HEAT PIPE SYSTEM

In the heat pipe system (Figure 7), refrigerant is vaporized in the evaporator end of each of the tubes mounted in a boiler within the oil sump. The refrigerant provides cooling for the transmission oil. A slight vapor pressure gradient drives the vapor up into the core of the plate tube condenser, where it is condensed by the rejection of heat to the air forced through the condenser by a belt-driven blower. Condensed liquid refrigerant returns to the oil cooler by gravity reflux down the tube walls. A dynamic circulation system is thus set up within each tube. Because each tube is independent of its neighbor, a puncture of one or more tubes by a projectile, out of the 260 tubes required, would not greatly affect the overall oil cooling capacity of the system.

VAPOR CYCLE SYSTEM

The vapor cycle system (Figure 8), which is a true refrigeration cycle, combines an evaporator in the oil sump with a condenser and blower in the same location as in the close-coupled oil-air system. The vapor cycle system employs

Refrigerant-11, which undergoes a constant-pressure change of phase from liquid to vapor as it absorbs heat from the transmission oil in the evaporator. The slightly superheated refrigerant vapor leaving the evaporator is compressed by a pump (stack-mounted on the present oil pump) to a higher pressure and temperature. The vapor leaving the compressor is cooled and condensed at constant pressure by rejecting its acquired heat to the air which is forced through the condenser by the blower. The high-pressure, slightly subcooled liquid refrigerant leaving the condenser is expanded across a throttling valve, and the resulting 2-phase mixture is fed to the evaporator to complete the cycle.

AIR CYCLE-AIR COOLING SYSTEM

This system (Figure 9) is mounted in the space immediately aft of the forward transmission, within the confines of the forward pylon. Air at atmospheric temperature and pressure passes through a compressor which raises the pressure and temperature. The compressor output is then passed through an air-to-air heat exchanger, where 90 percent of the compression heat is removed by atmospheric cooling air which is forced through the heat exchanger by a blower. The air is then expanded through a cooling turbine to a pressure slightly less than atmospheric, which reduces the temperature by removing energy in the expansion process. The cooled air then travels through a duct to an oil-air heat exchanger, located within the forward transmission oil sump, which reduces the oil temperature to the required level. The air is then exhausted from the heat exchanger and ducted overboard.

ABSORPTION SYSTEM

The absorption cycle refrigeration system is shown in Figure 10. The refrigerant used for this analysis was ammonia, with water as the absorbent. If ammonia is an objectionable refrigerant for use in an aircraft, a lithium bromide/water combination could be used; however, the results of this study show that this system is not competitive. Therefore, the change of refrigerant would have little effect on the rating of this system in the study.

Figure 11 shows that the liquid ammonia leaves the condenser in a saturated condition and enters the precooler, where it is subcooled by refrigerant vapor from the evaporator. The subcooled liquid is then reduced in pressure by the expansion valve and enters the evaporator, where it vaporizes by absorbing the heat from the transmission oil.

From the evaporator, within the oil sump, the ammonia vapor passes through the precooler and enters the absorber. The ammonia is assumed to be dry from the condenser to the absorber in this analysis. In the actual system, however, there would be a small amount of water mixed with the ammonia (i.e., less than 1 percent). A temperature control may be necessary to prevent the water from freezing.

In the absorber, the ammonia vapor is absorbed in a weak solution of ammonia and water. Absorption of the ammonia lowers the pressure in the absorber, which in turn draws more ammonia vapor from the evaporator. Cooling is required in the absorber to remove the heat of condensation and the heat of solution evolved there. For this system, an air-to-liquid heat exchanger is used where atmospheric air is drawn through the exchanger by a blower.

The resulting strong solution of ammonia and water is then pressurized by a liquid pump and passes through a liquid-liquid heat exchanger, where its temperature is raised by the weak solution coming from the generator.

The strong solution enters the generator where heat is added. The heat vaporizes the ammonia, driving it out of solution and into the condenser where the heat of vaporization is removed by the atmosphere.

The weak solution left in the generator after the ammonia has been driven off flows through the liquid-liquid heat exchanger, through a pressure-reducing valve, and back to the absorber to be recycled.

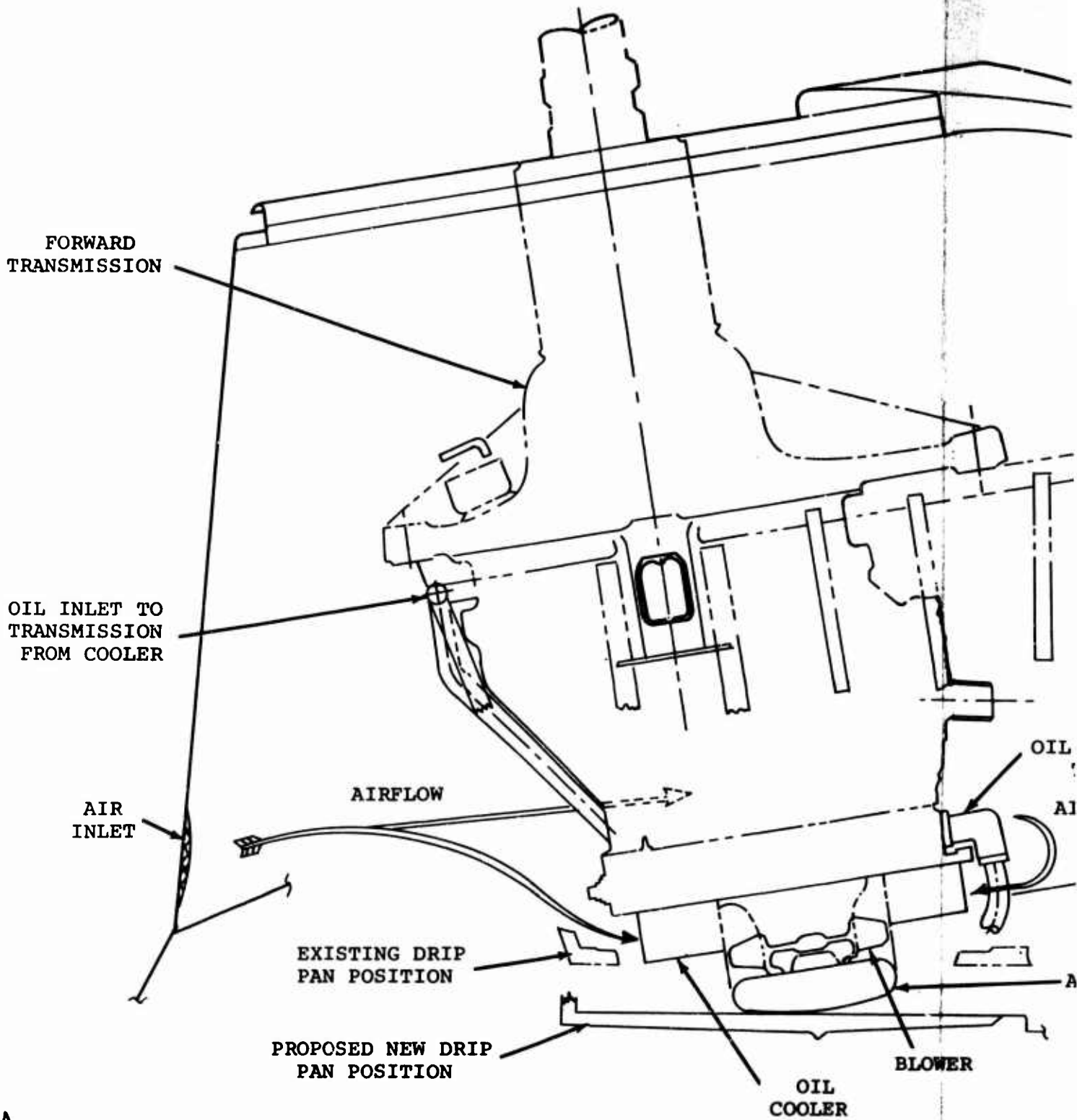
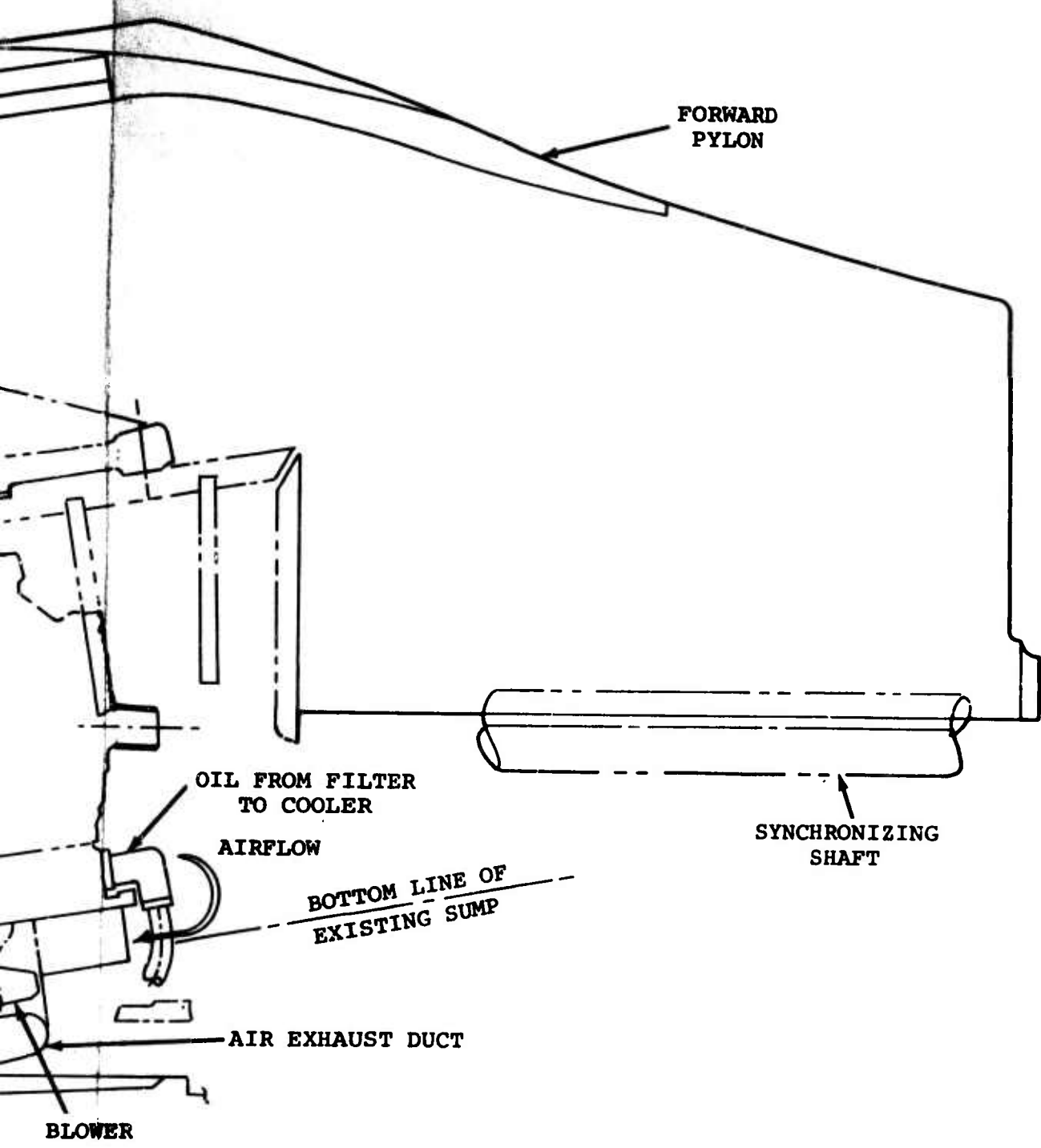

Figure 1. Integral Oil-Air System.



FORWARD
PYLON

OIL FROM FILTER
TO COOLER

AIRFLOW

BOTTOM LINE OF
EXISTING SUMP

AIR EXHAUST DUCT

BLOWER

SYNCHRONIZING
SHAFT

B

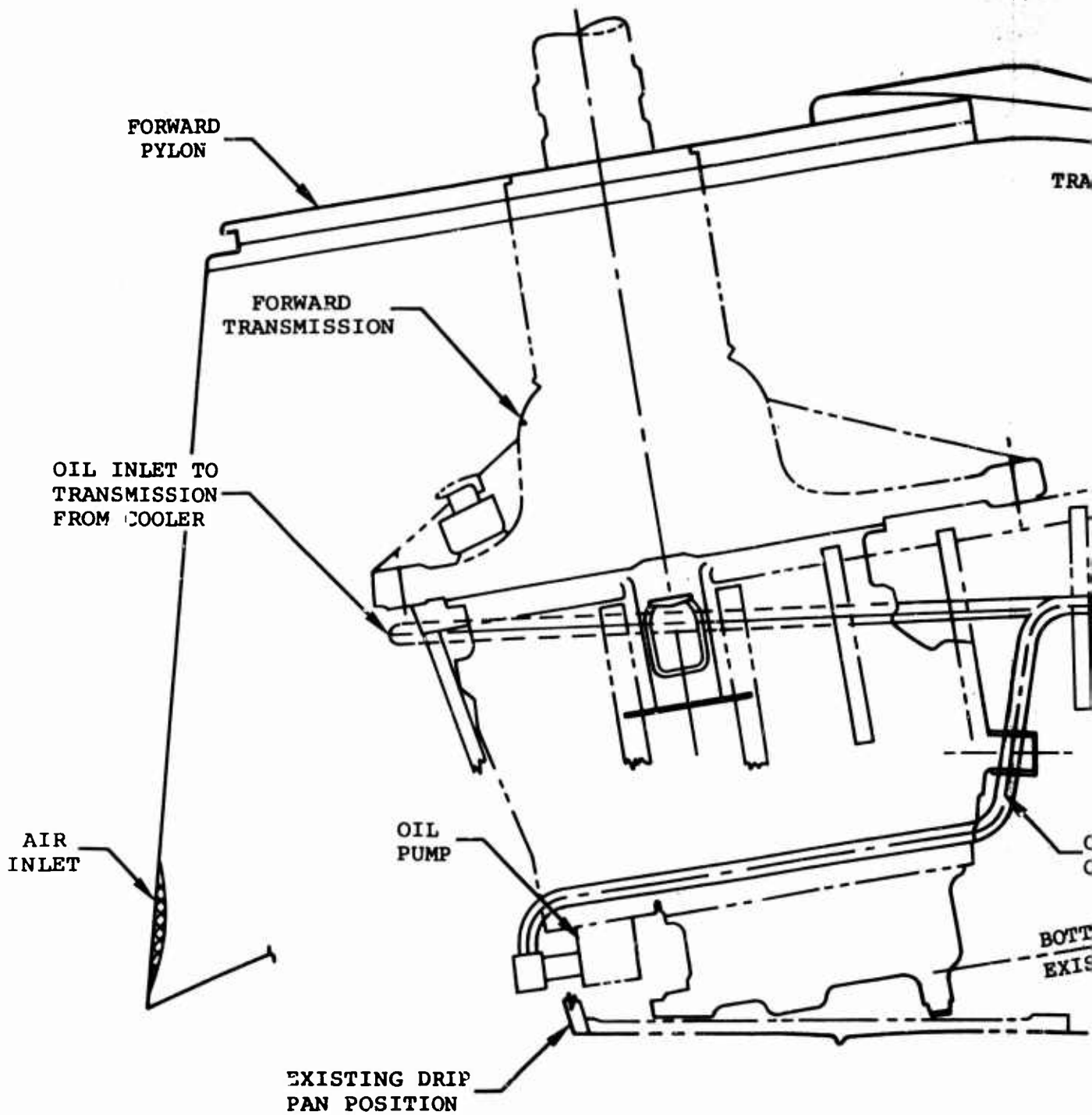
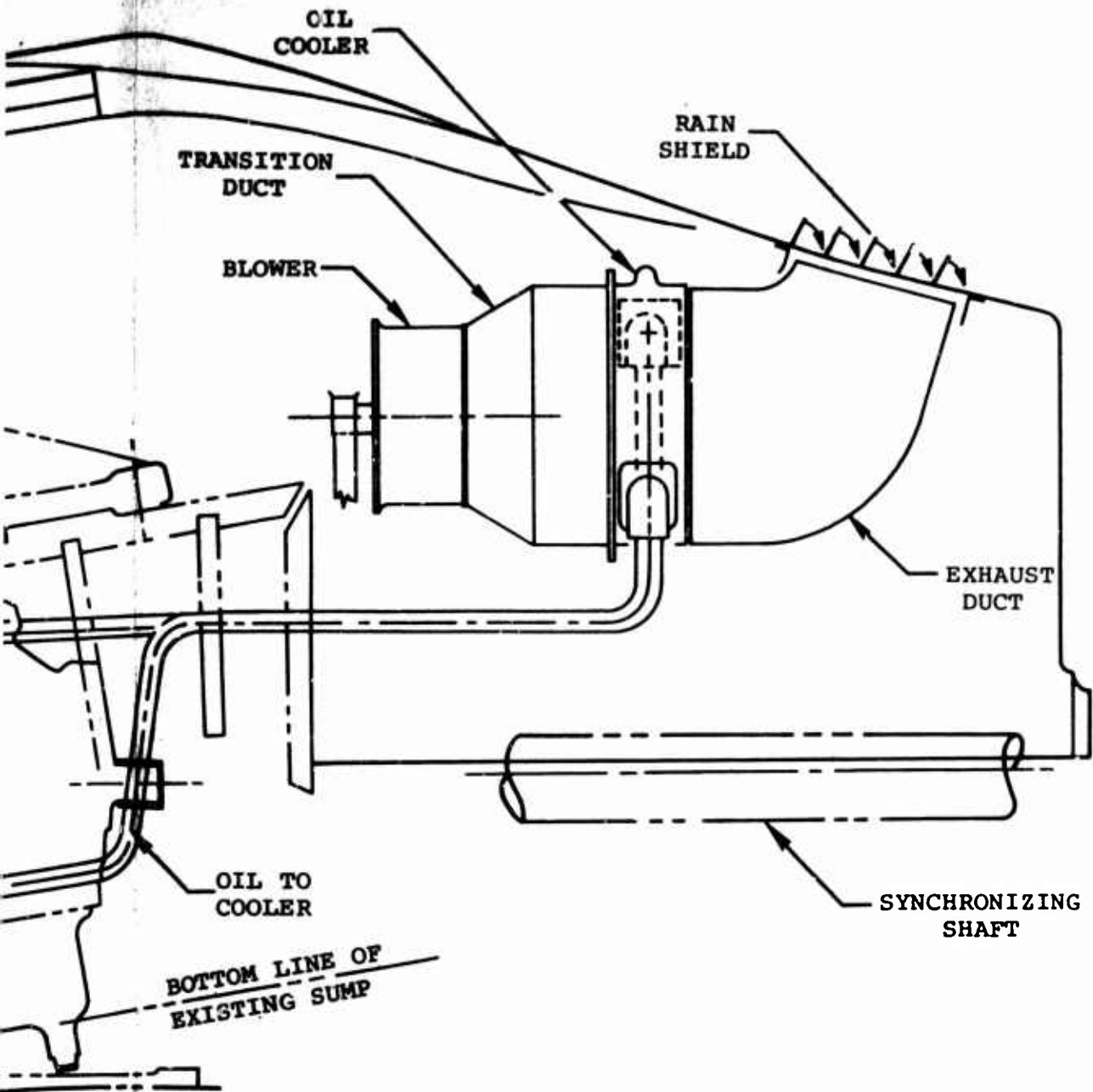

Figure 2. Close-Coupled Oil-Air System.



B

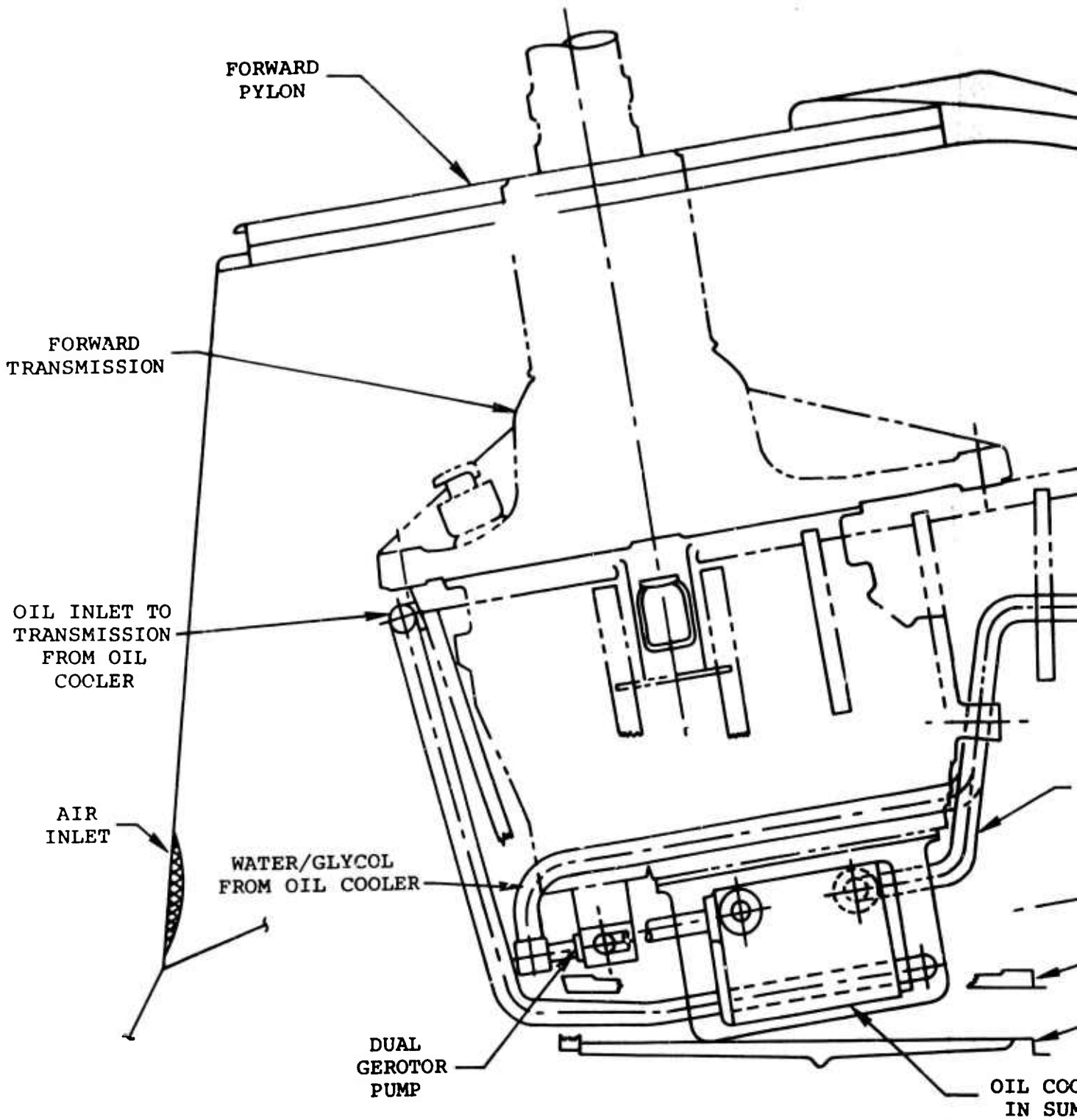
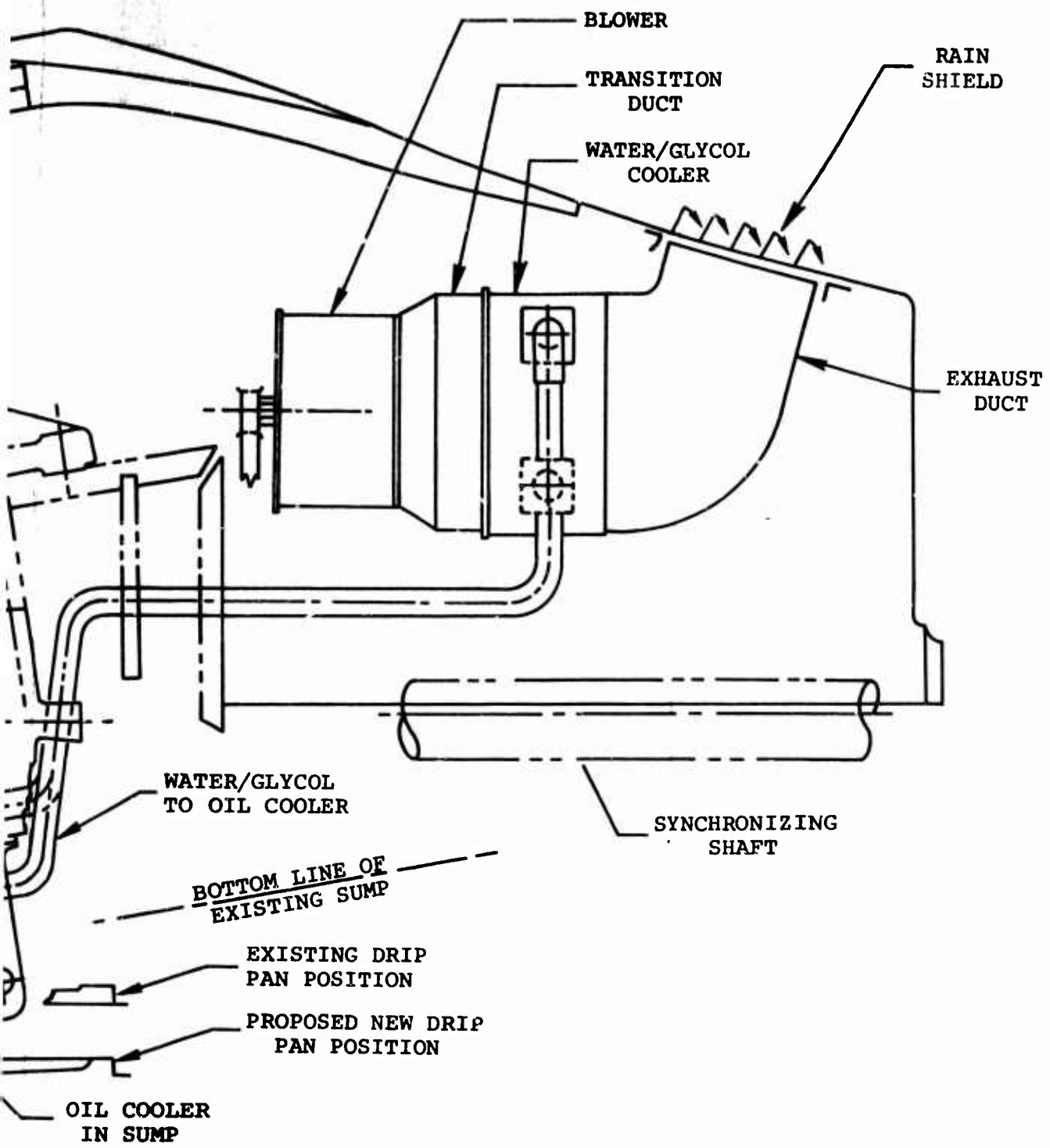

Figure 3. Oil-Water/Glycol-Air System.

A



B

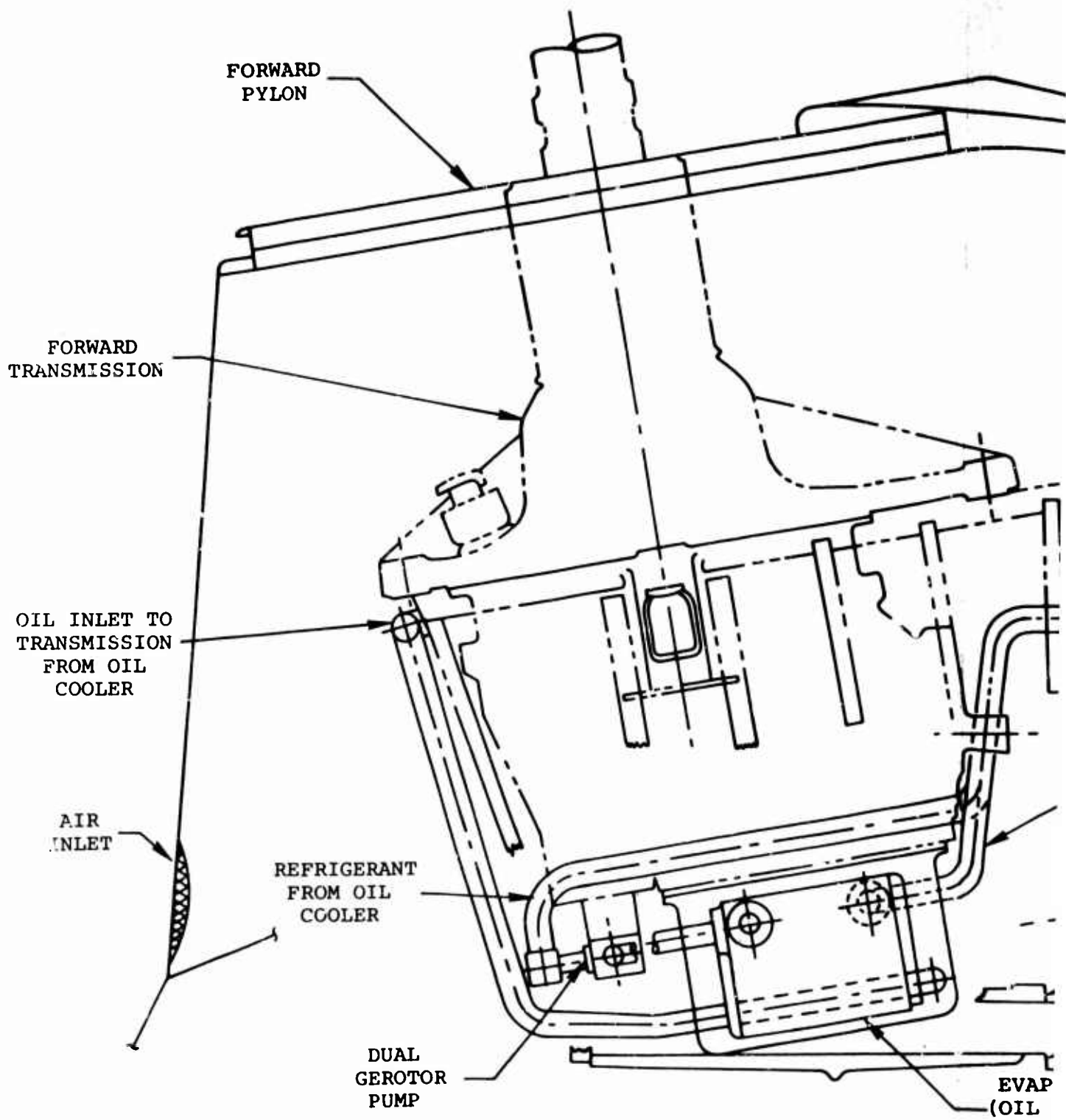
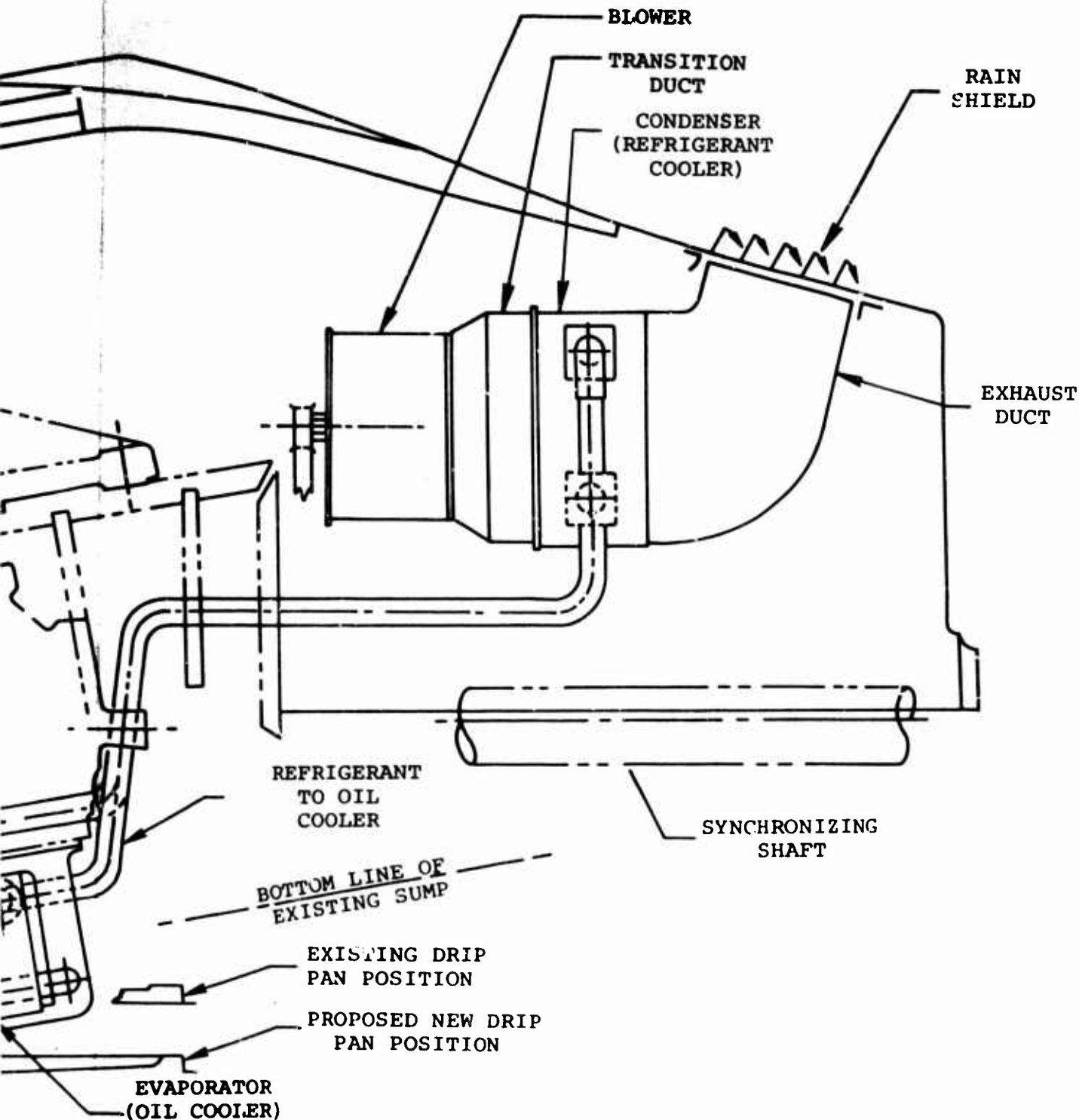

Figure 4. Oil-Boiling Refrigerant-Air System.

A



B

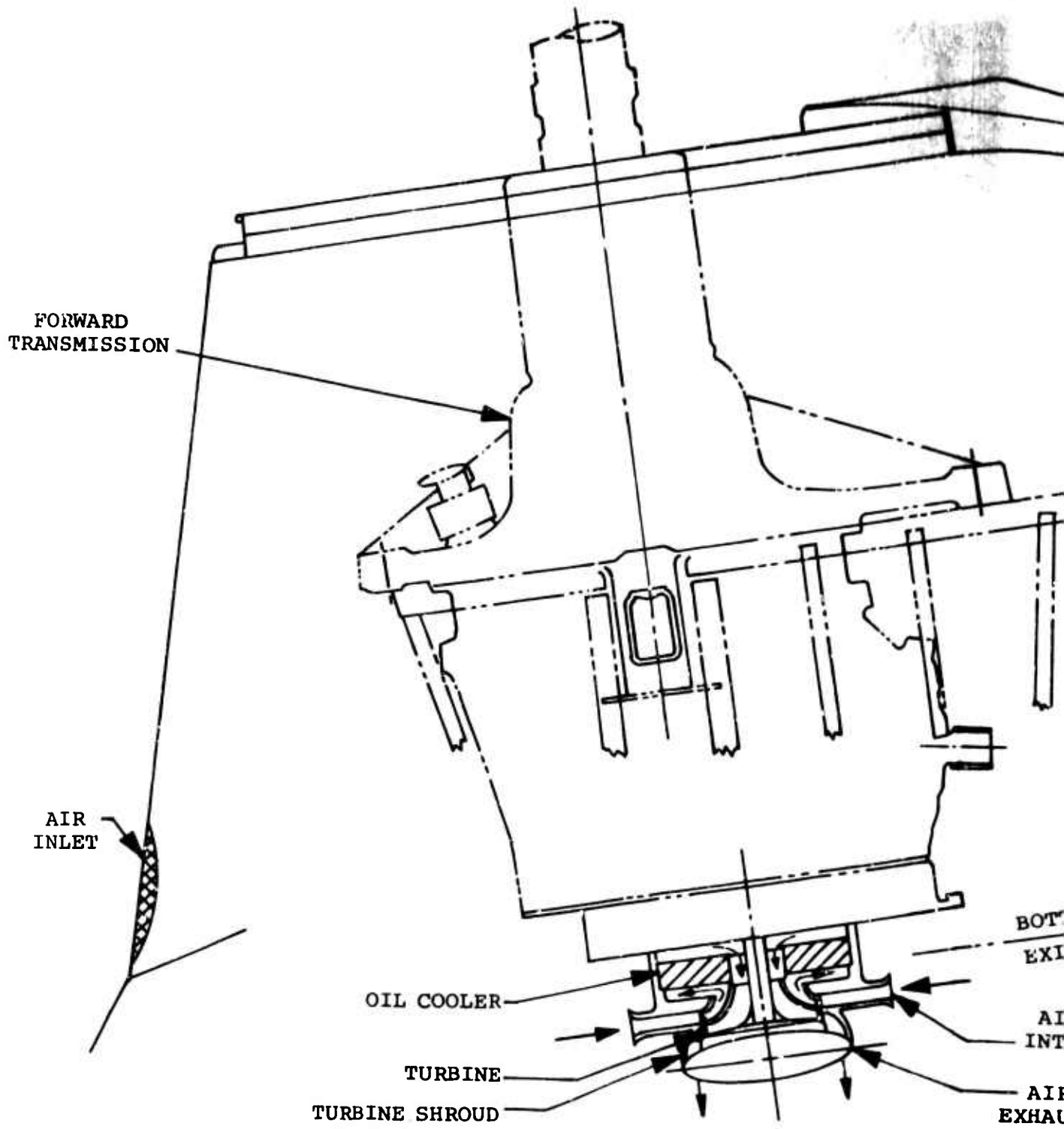
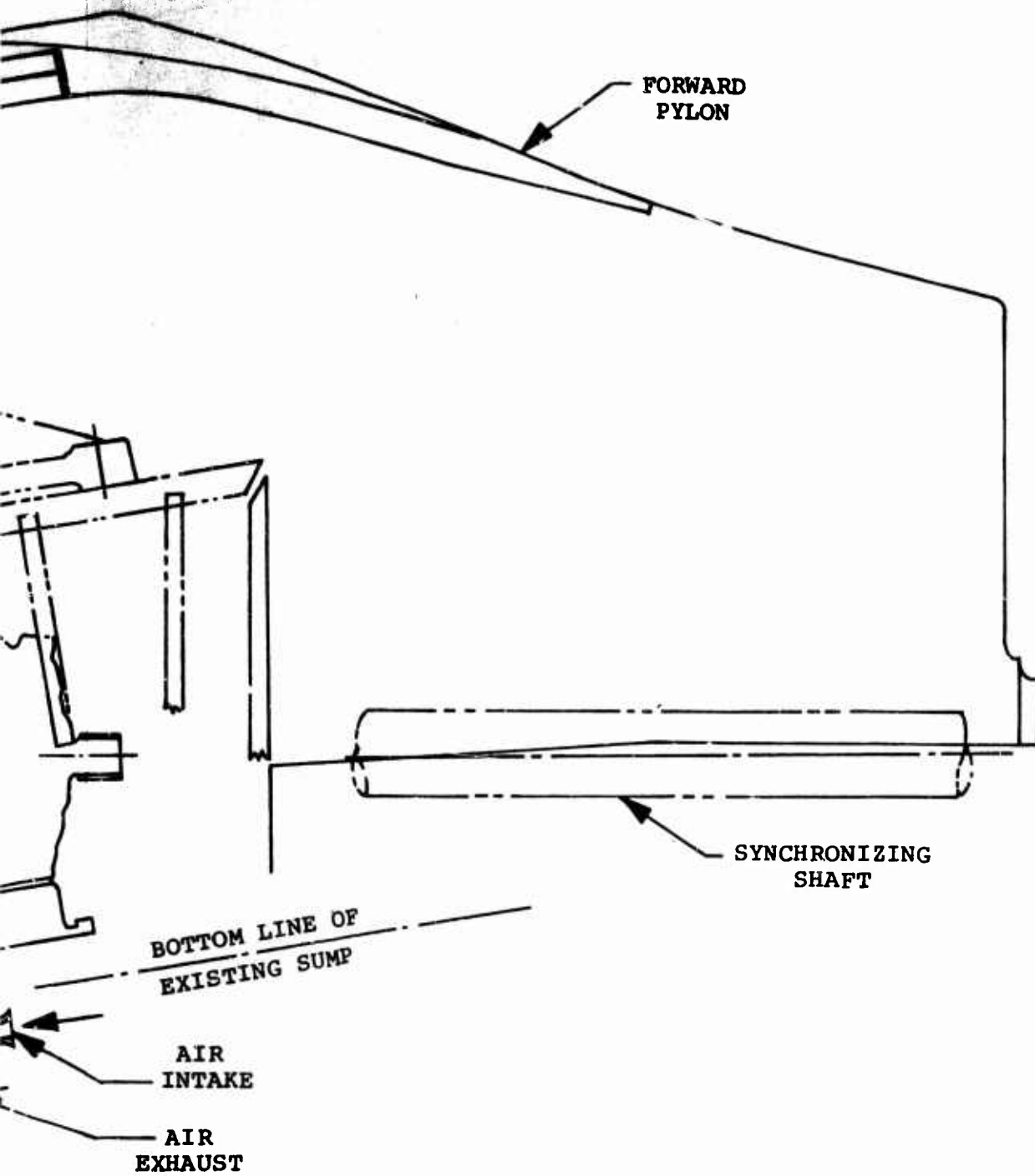

Figure 5. Air Cycle-Heat Pump System.

A



B

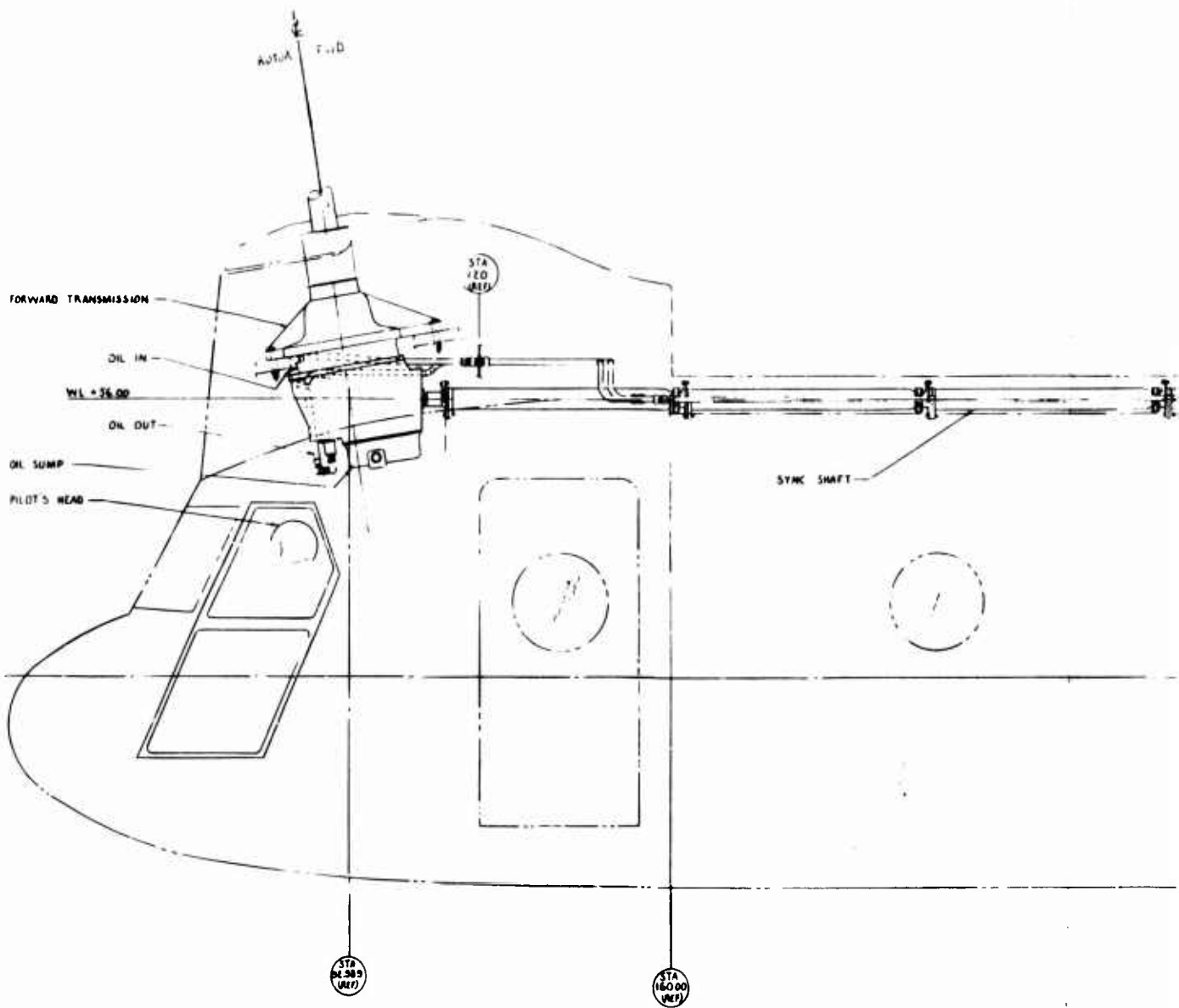
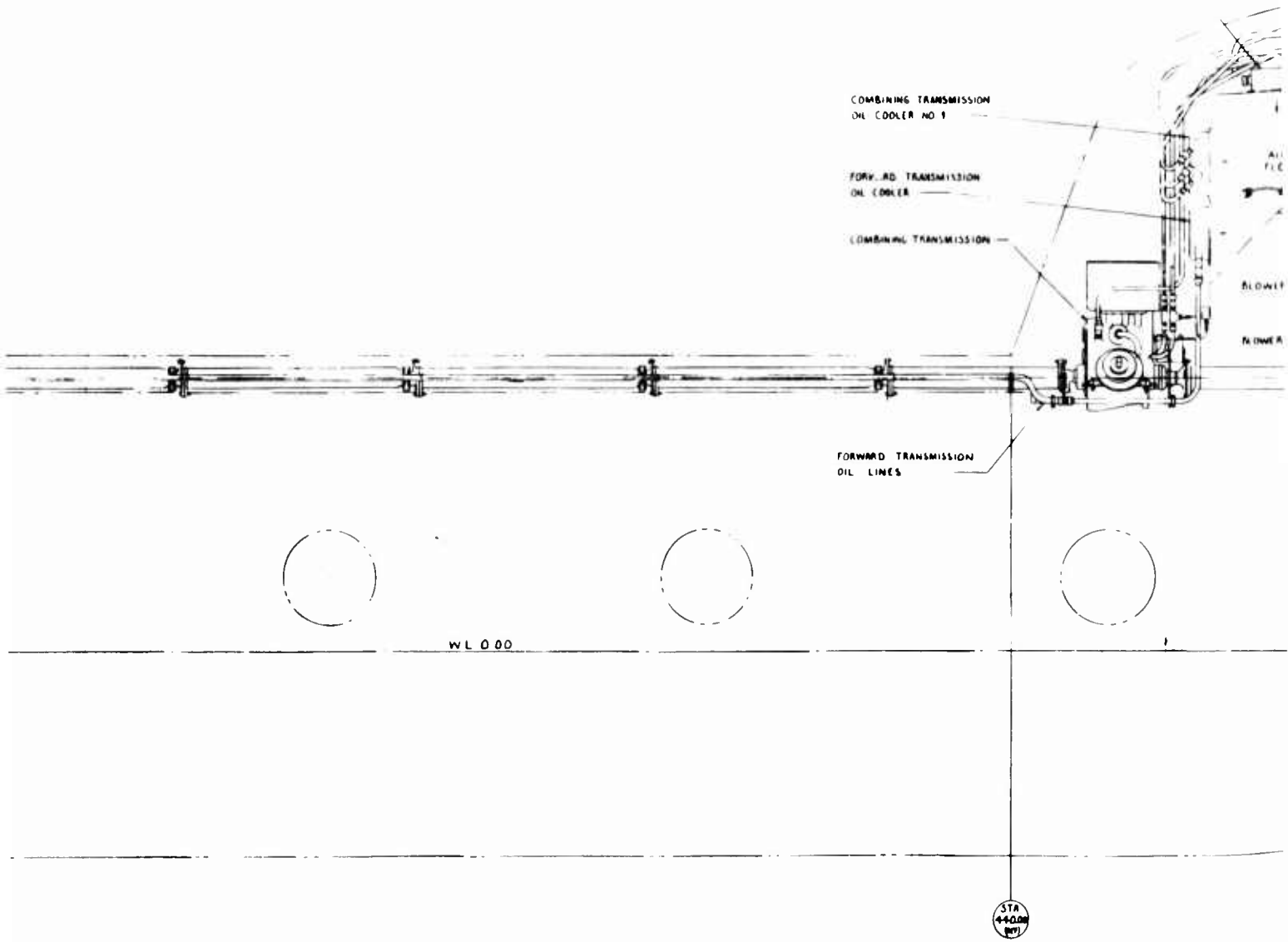

Figure 6. CH-47 Production System.

A

AFT TRANSMISSION OIL COOLER —
COMBINING OIL COOLE



B

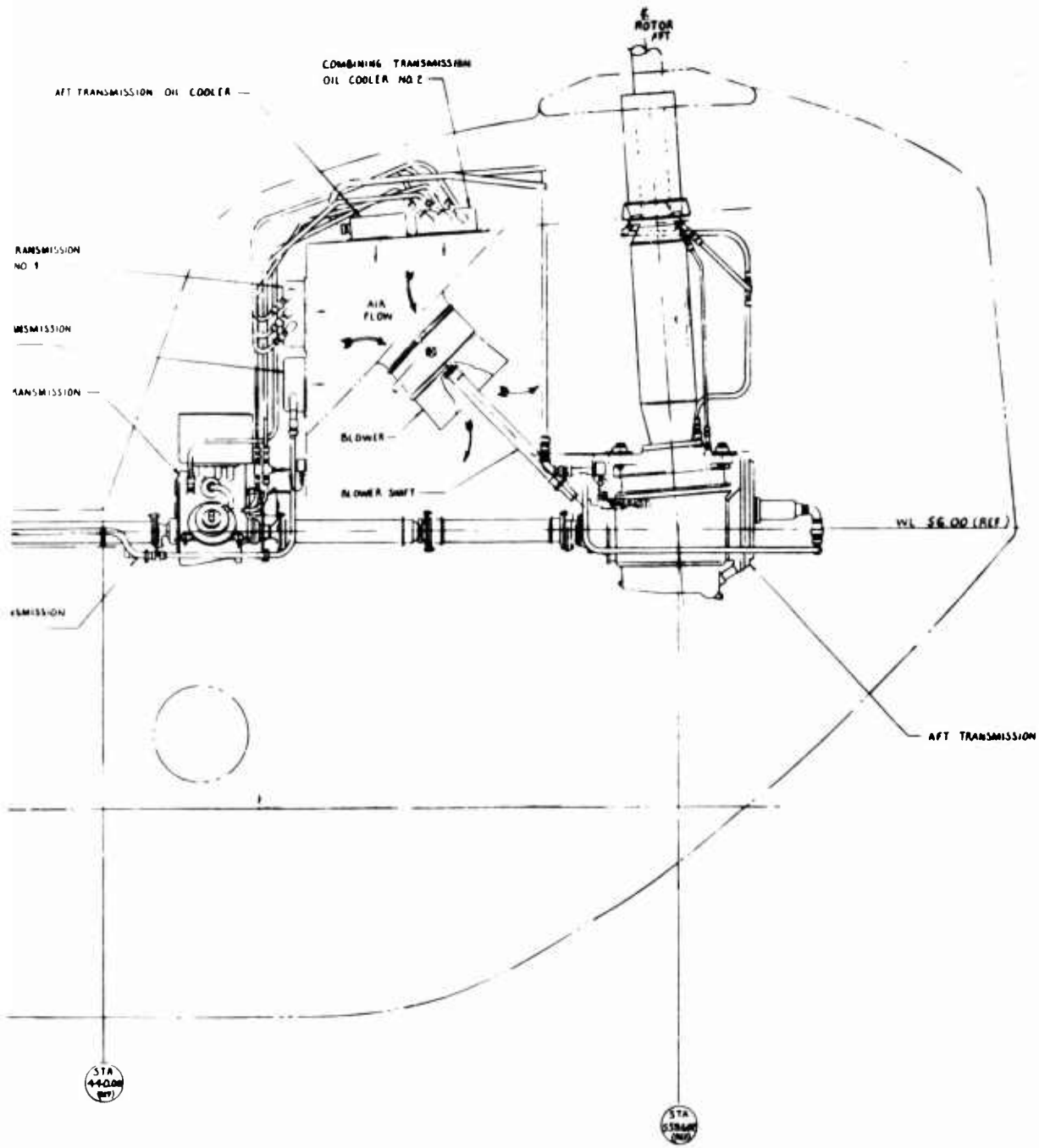

C

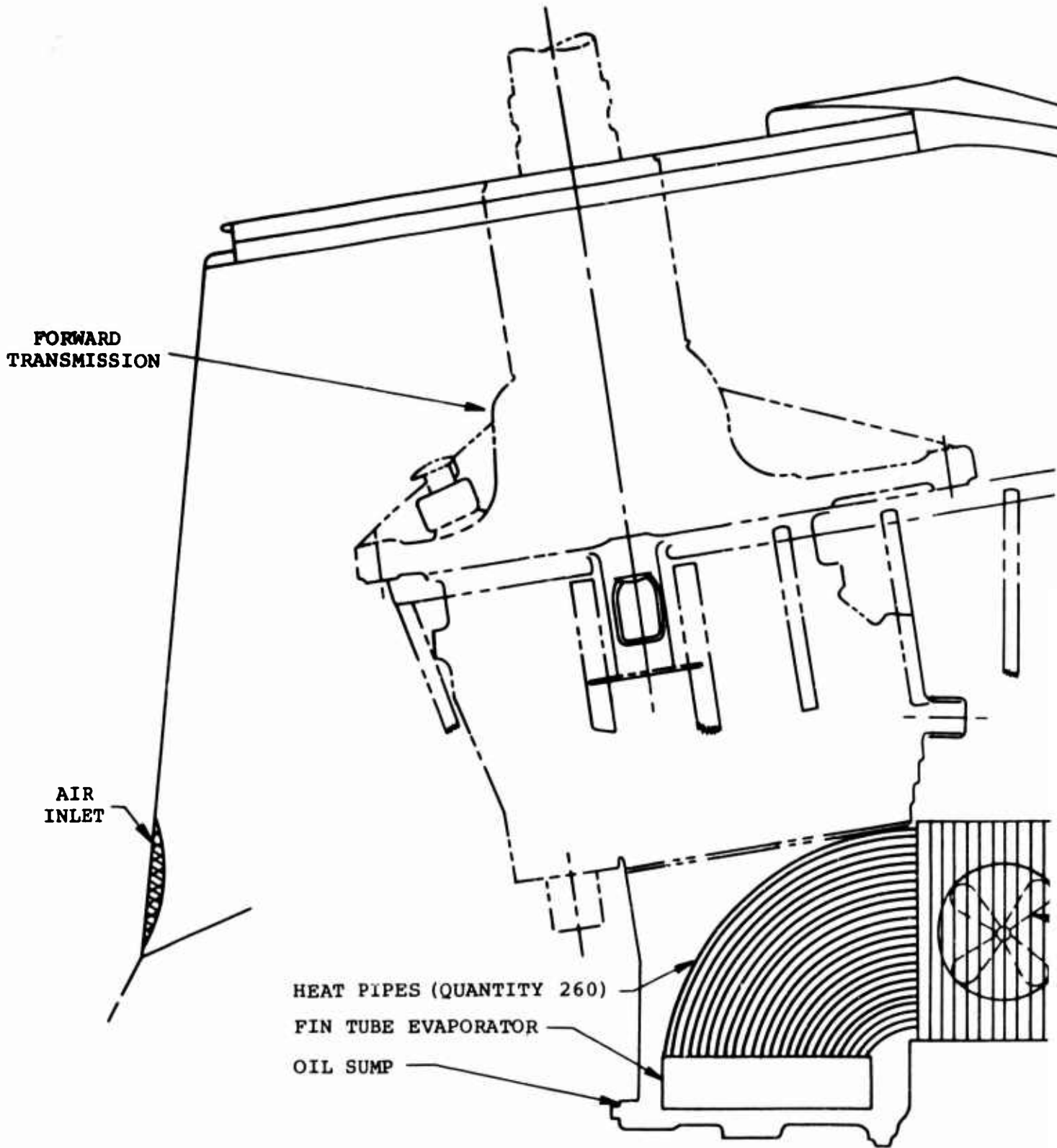
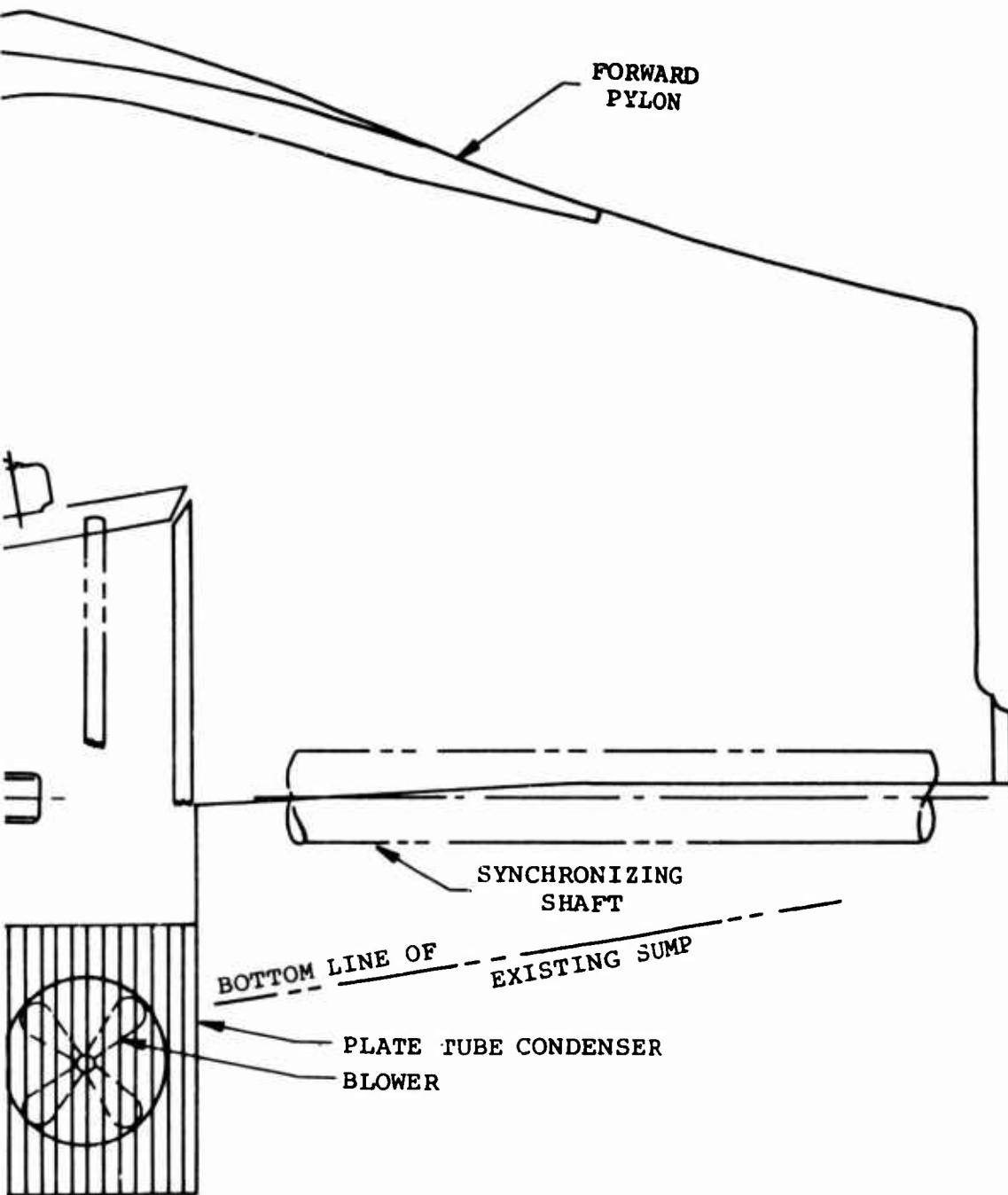

Figure 7. Heat Pipe System.

A



B

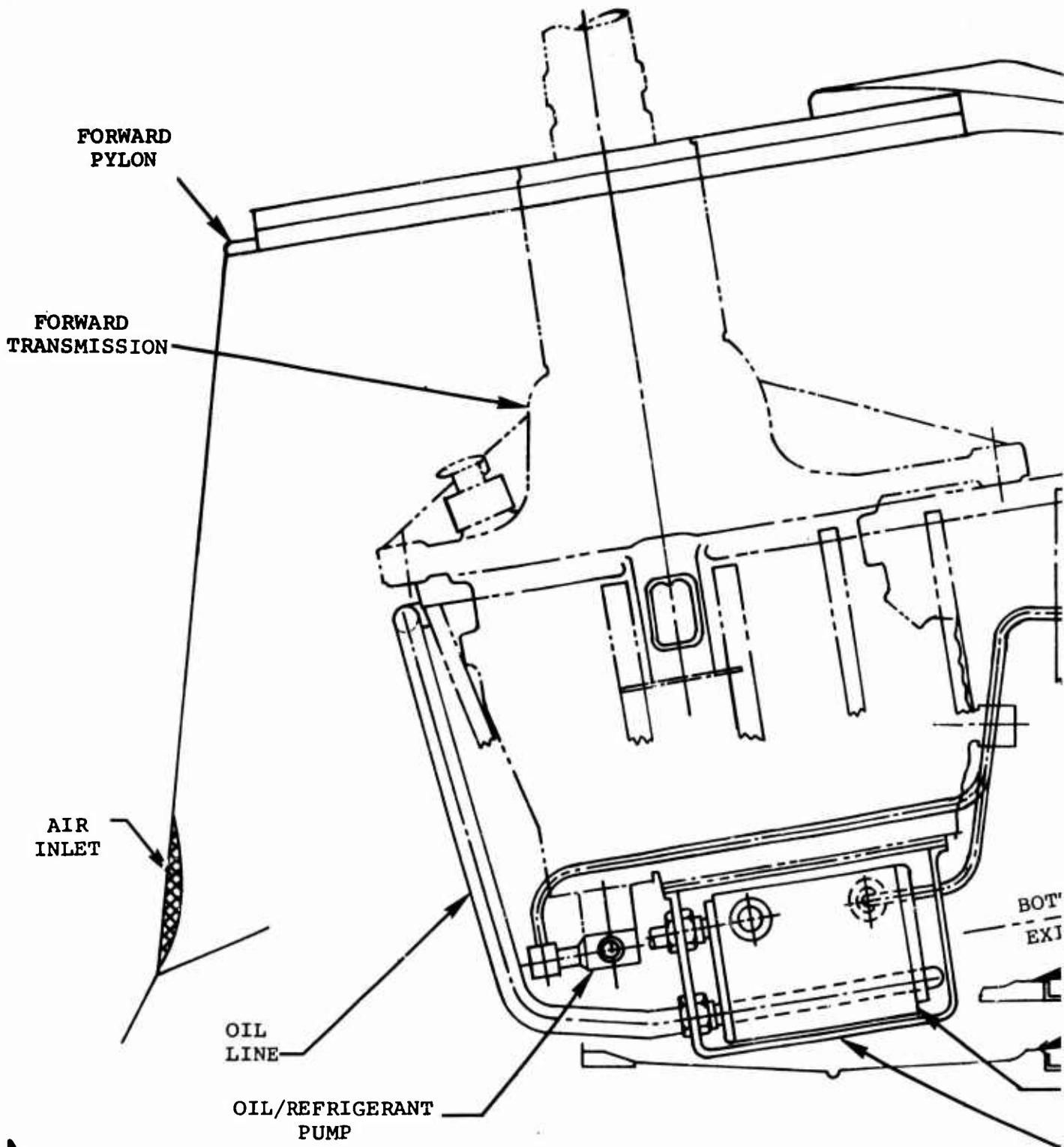
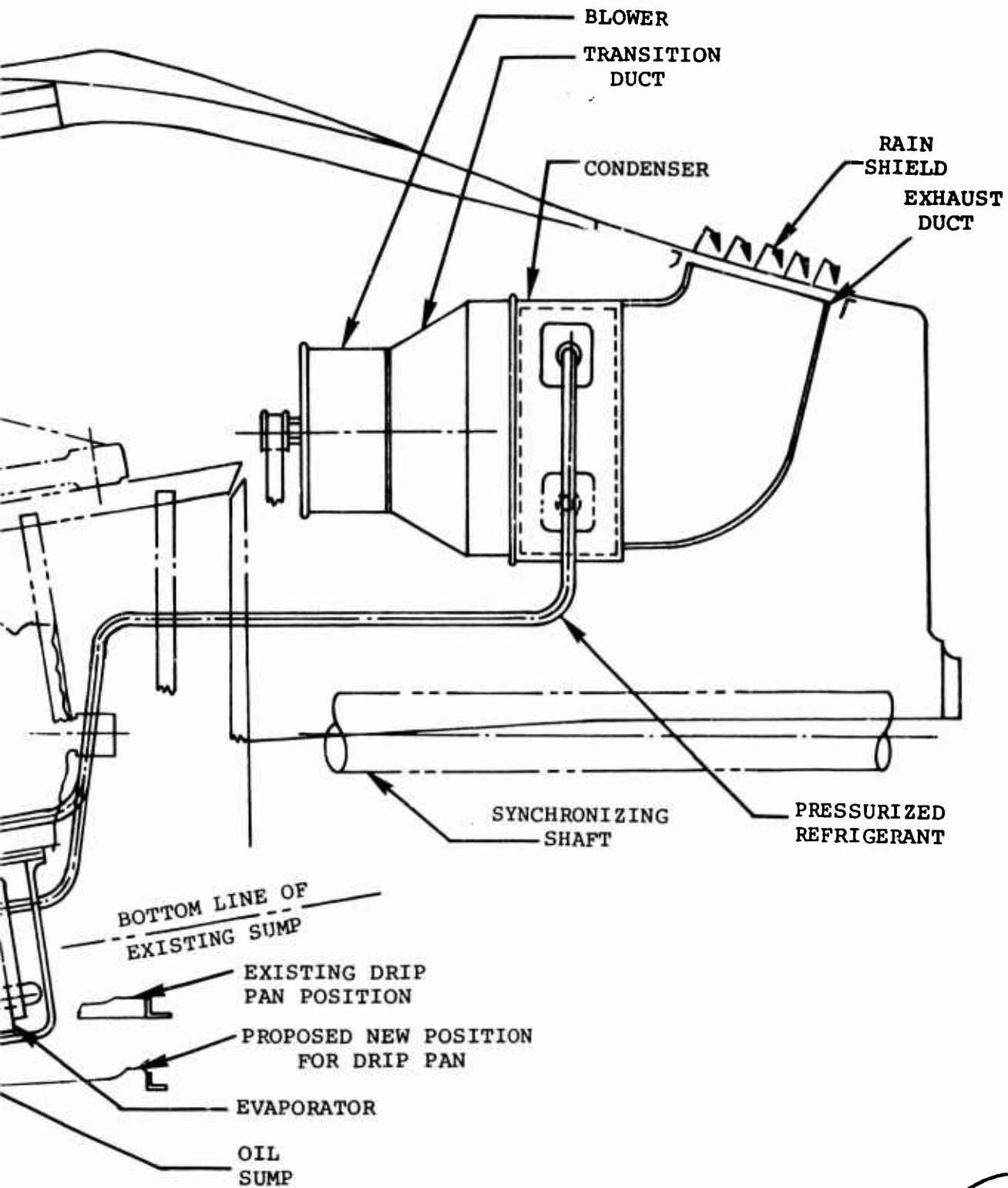

Figure 8. Vapor Cycle System.

A



BA

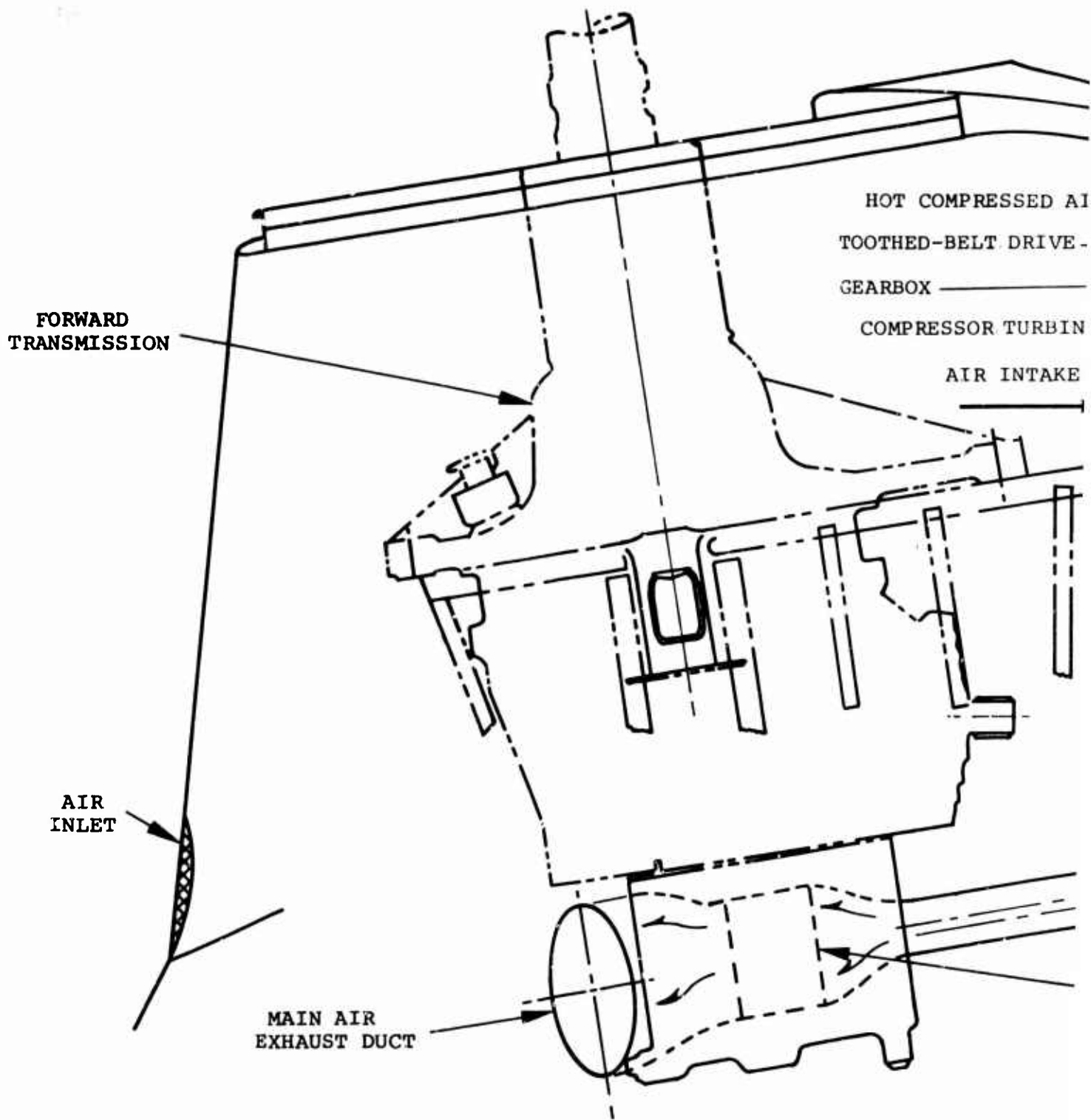
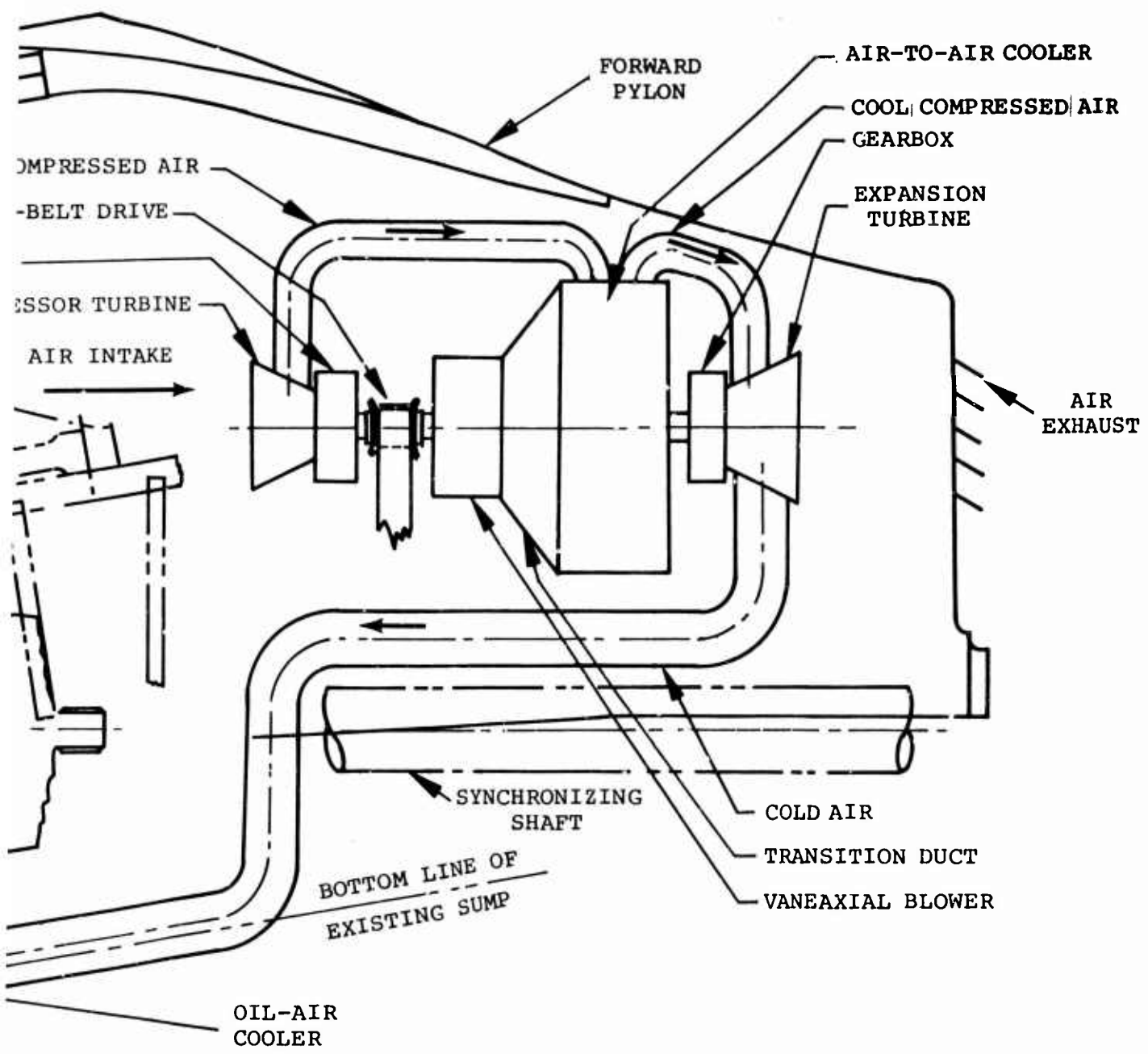

Figure 9. Air Cycle-Air Cooling System.

A



B

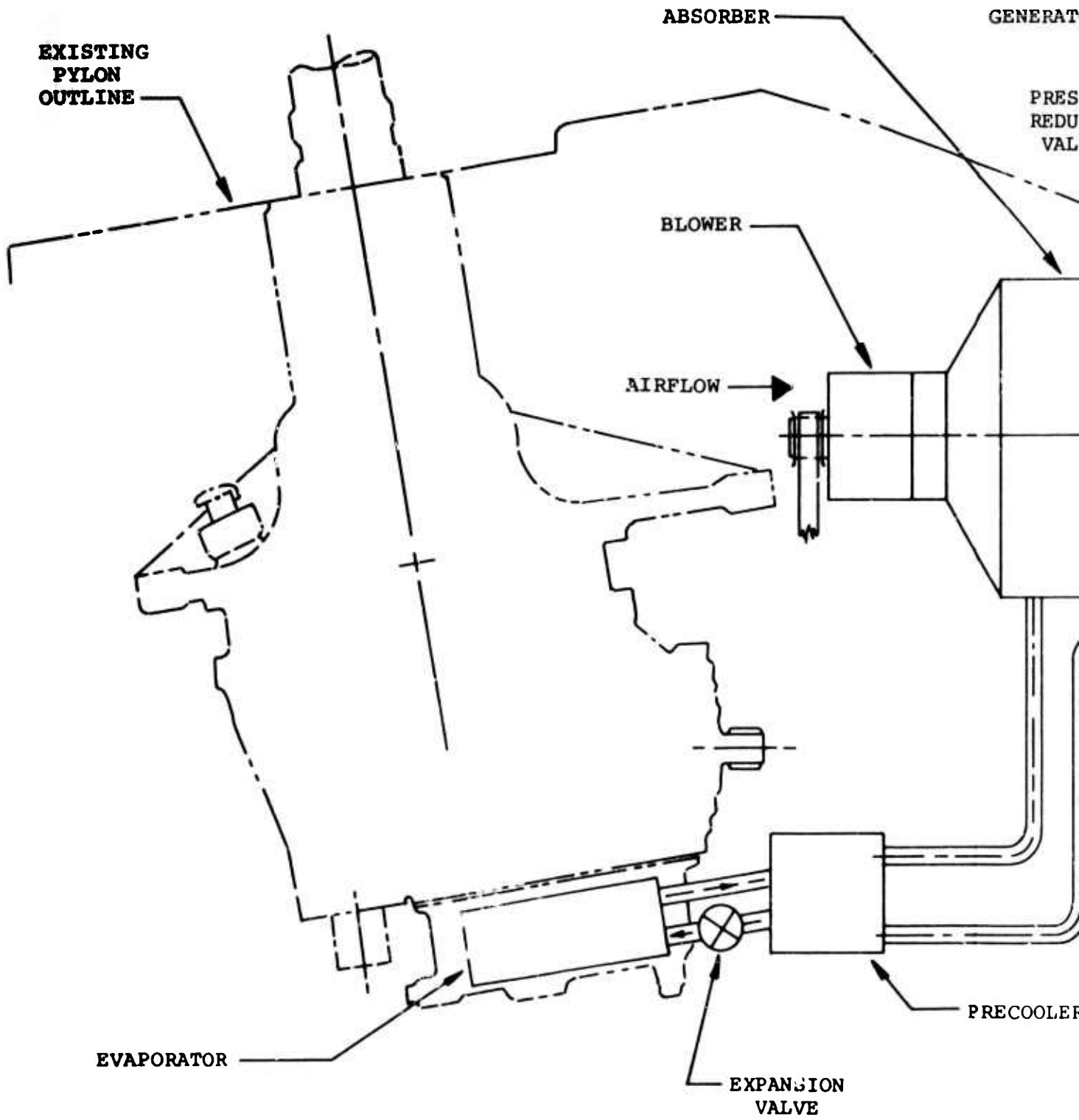
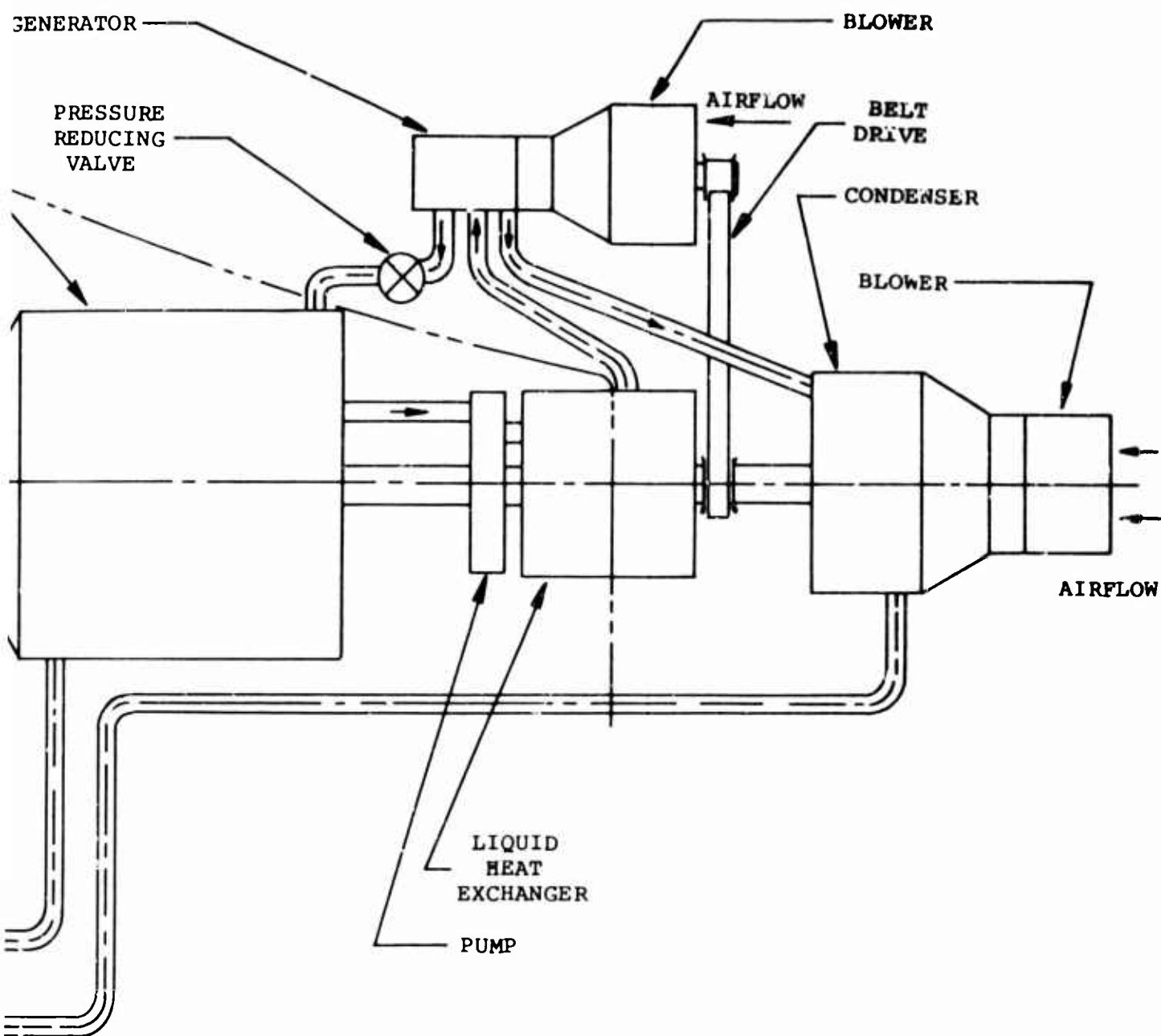

Figure 10. Absorption System.

A



B

BLANK PAGE

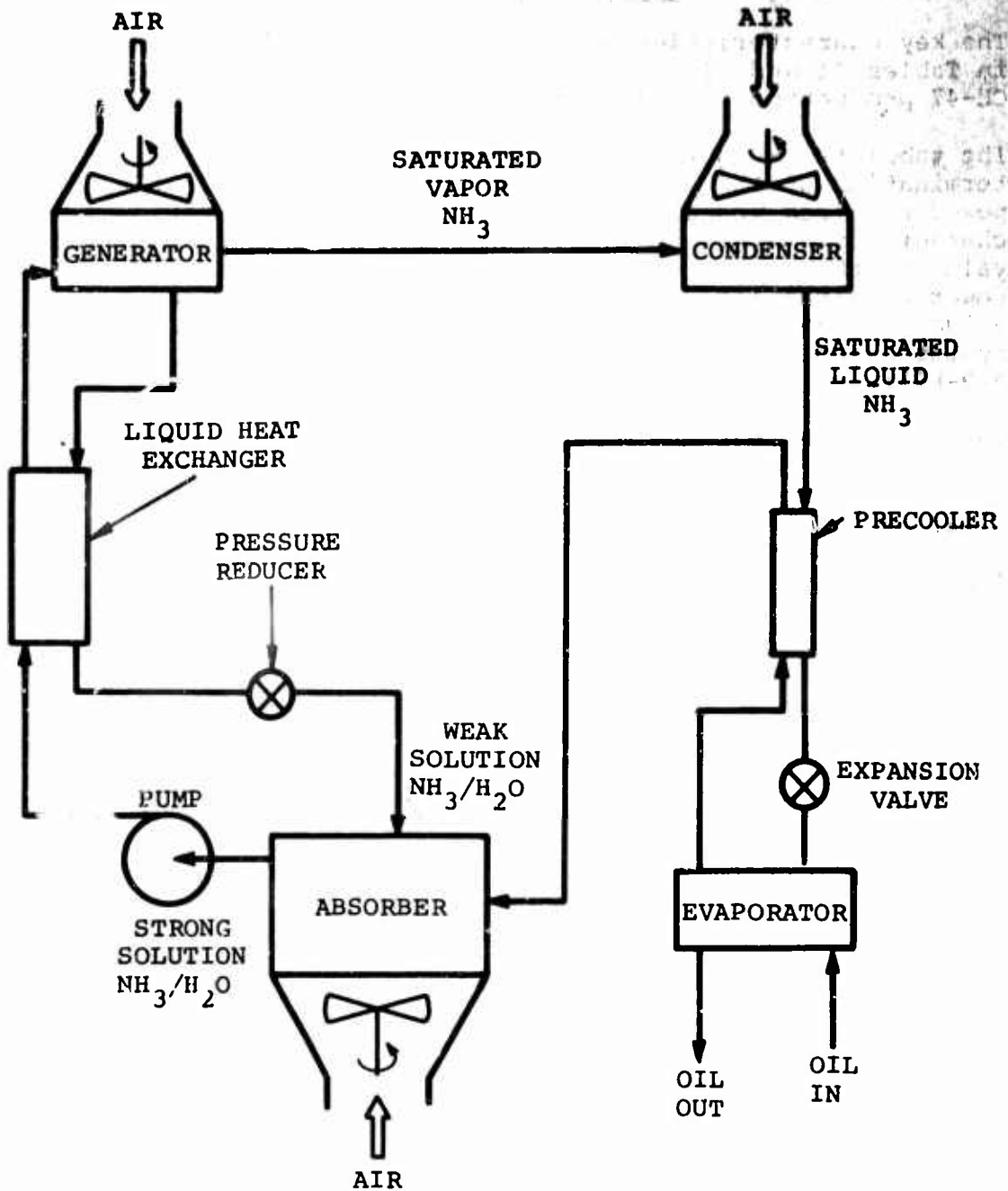

- NOTES: 1. NH₃ = AMMONIA
 2. H₂O = WATER

Figure 11. Absorption System Operational Cycle.

SYSTEM CHARACTERISTICS

The key characteristics of the systems studied are summarized in Tables II and III, along with the characteristics of the CH-47 production system which was used as a baseline reference.

The tabulated weight values are based on a careful weight determination of the various system components, while the horsepower required was dictated by the sizing and operation characteristics of the various systems. The equivalent weight value is the summation of the hardware weight and the horsepower required (at 7 lb/hp penalty). Total major component volume is the actual physical size of the components in each system which, if hit by a projectile, would result in an A- or a B-kill.

Table III presents the system component cost, failure rate, replacement component cost, and maintenance time, as determined from vendor information, CH-47 field data, U.S. Navy FARADA data, and available fixed-wing aircraft data. All data were carefully analyzed, using the CH-47 data as a reference baseline, in order to insure that the final data are representative.

TABLE II. SUMMARY OF SYSTEM PHYSICAL CHARACTERISTICS

System Description	System Hardware Weight, including Liquids (lb)	System Horsepower	System Equivalent Weight (lb)	Total Major Component Volume, A- & B-Kill* (in.3)
Integral Cil-Air	36.9	3.7	63	990
Close-Coupled Oil-Air	64.5	2.9	85	1,355
Oil-Water/Glycol-Air	107.4	8.6	168	2,071
Oil-Boiling Refrigerant-Air	109.3	8.7	170	2,050
Air Cycle-Heat Pump	70.0	17.7	124	365
CH-47 Production	90.1	4.2	120	2,643
Heat Pipe	135.4	2.7	154	4,464
Vapor Cycle	114.9	9.9	184	2,383
Air Cycle-Air Cooling	127.3	24.7	300	2,808
Absorption	313.5	17.1	433	12,374

*Volume of major components which, if hit, will result in an A- or a B-kill

TABLE III. SUMMARY OF SYSTEM COST, RELIABILITY, AND MAINTAINABILITY CHARACTERISTICS

System Description	Initial Component Cost (dollars)	System Failure Rate/6,000 Flight Hours	Replacement Component Cost (dollars)	Scheduled and Unscheduled Maintenance	
				Man-Hours/6,000 Flight Hours	Flight Hours
Integral Oil-Air	2,517	33.0	3,710		340
Close-Coupled Oil-Air	1,705	40.6	4,638		335
Oil-Water/Glycol-Air	3,410	66.6	7,482		381
Oil-Boiling Refrigerant-Air	3,410	71.2	7,997		388
Air Cycle-Heat Pump	9,866	110.0	12,366		478
CH-47 Production	1,800	45.4	4,970		467
Heat Pipe	5,968	44.9	5,049		341
Vapor Cycle	7,843	260.1	29,216		680
Air Cycle-Air Cooling	9,378	148.6	16,695		519
Absorption	16,368	194.1	21,806		852

SYSTEM ANALYSIS METHOD

The nine systems studied were all analyzed on the basis of vulnerability, equivalent weight, reliability, maintainability, and system cost. A method of relating all the various values to a dollar cost, for one aircraft out of a fleet of 250 over a 10-year period, was devised so that the values could be interrelated and a total common value could be ascertained. A slight inaccuracy in the various ratings will not affect the overall rating, since any change to the base will change all systems; thus, each system will maintain its ranking position. An example of the procedure used to arrive at the various values for each system is shown for the close-coupled oil-air system and for the CH-47 production system; the results of the calculations for the remaining systems are presented in Table X.

VULNERABILITY EVALUATION

The following is a brief summary of some combat statistics recorded for the CH-47 helicopter during a 29-month period of operation in Vietnam. Actual damage figures have been reduced and related to an idealized fleet of 100 aircraft operating in a Vietnamese environment for this time span.

Combat Hits

.30 caliber	590	. $\frac{590}{621} \times 100\% = 95\%$ of the com-
.50 caliber	24	bat hits were
Other	7	caused by .30
Total	621	caliber arms

Significant Hits

Drive system	24	. $\frac{24}{304} \times 100\% = 7.9\%$ of the
All other	280	significant hits
Total	304	were in the
		drive system

Mission Aborts

Drive system caused	5
All other causes	49
Total	54

Out of every 54 aborts there were 5 strikes; however, these strikes were not always due to hard or crash landings. Some aircraft were intentionally destroyed because of the position of the enemy.

This information indicates that 5/54 or 9.26 percent of the aircraft aborts result in a strike. Of the 24 drive system hits, 9 were in the transmission cooling systems; of these 9 hits, 7 were in the forward transmission oil cooling system, resulting in a loss of oil to that system. Since any loss of oil to a transmission necessitates a forced landing (mission abort), an aircraft loss of 9.26 percent x 7, or 0.648 aircraft, can be assumed over a 29-month period for a fleet of approximately 100 aircraft, due to a hit in the forward transmission oil cooling system.

Assuming a fleet of 250 aircraft in this type of environment for 10 years, an aircraft loss figure due to hits in the forward transmission oil cooling system can be calculated.

Time Period Ratio

$$\frac{29 \text{ months}}{0.648 \text{ aircraft}} = \frac{10 \text{ years} \times 12 \text{ months}}{X \text{ aircraft}}$$

$$X = \frac{120}{29} \times 0.648 = 2.68 \text{ aircraft}$$

Aircraft Quantity Ratio

$$\frac{100 \text{ aircraft}}{2.68 \text{ aircraft}} = \frac{250 \text{ aircraft}}{Y \text{ aircraft}}$$

$$Y = \frac{250}{100} \times 2.68 = 6.7 \text{ aircraft}$$

Based on present combat information and assuming the same conditions, a loss of 6.7 aircraft out of a fleet of 250 over a 10-year period due to hits in the forward transmission oil cooling system can be expected.

The Chinook helicopter is now flying an average of approximately 50 hours per month; using this rate and forecasting this average for 10 years, a total aircraft life of 6,000 flight hours is obtained.

VULNERABILITY RATING (Figure 12)

CH-47 combat damage statistics indicate a 2:1 ratio of A-kills to B-kills for the drive system. This study will consider only A- and B-kills for the vulnerability rating, since these are the only meaningful kills to the forward transmission oil cooling system.

Therefore,

A-kill vulnerable volume (in.³) x 2 = A-kill index

B-kill vulnerable volume (in.³) x 1 = B-kill index

Total = system vulnerability index

Examples

	<u>CH-47 Production System</u>	<u>Close-Coupled Oil-Air System</u>
Total vulnerable volume	2,643 in. ³	1,355 in. ³
A-kill volume x 2	1,983 x 2 = 3,966	1,027 x 2 = 2,054
B-kill volume x 1	660 x 1 = <u>660</u>	328 x 1 = <u>328</u>
System vulnerability index	4,626	2,382

For a fleet of 250 CH-47 aircraft over a 10-year period, it was shown that a loss of 6.7 aircraft would occur due to hits in the forward transmission oil cooling system. The approximate dollar value of a CH-47 helicopter, including GFE items, amounts to \$1,310,000; thus, the cost per aircraft will be:

$$\frac{6.7 \text{ aircraft} \times \$1,310,000/\text{aircraft}}{250 \text{ aircraft}} = \$35,108.$$

Since the \$35,108 cost per aircraft is based on the CH-47 production aircraft, a cost-index value can be put on the system vulnerability index.

$$\frac{\$35,108}{4,626} = \$7.59/\text{system vulnerability index unit}$$

Example

<u>CH-47 Production System</u>	<u>Close-Coupled Oil-Air System</u>
4,626 in. ³ x \$7.59 = \$35,108	2,382 in. ³ x \$7.59 = \$18,079

Therefore, the vulnerability ratings are as follows:

CH-47 Production System - \$35,108
 Close-Coupled Oil-Air System - \$18,079

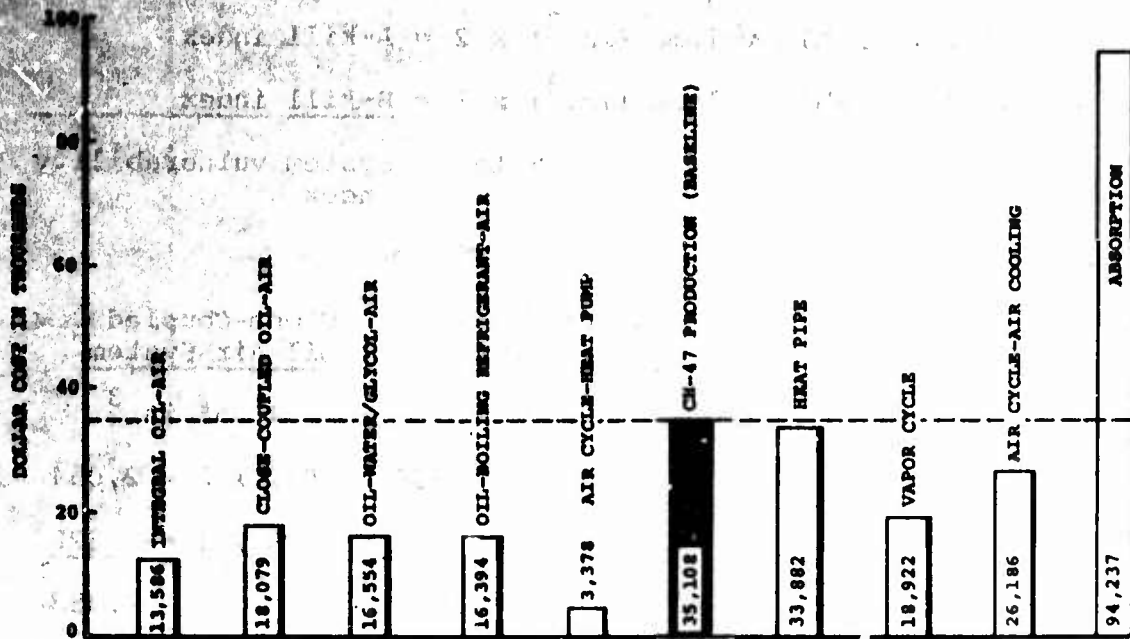

Figure 12. Vulnerability Rating

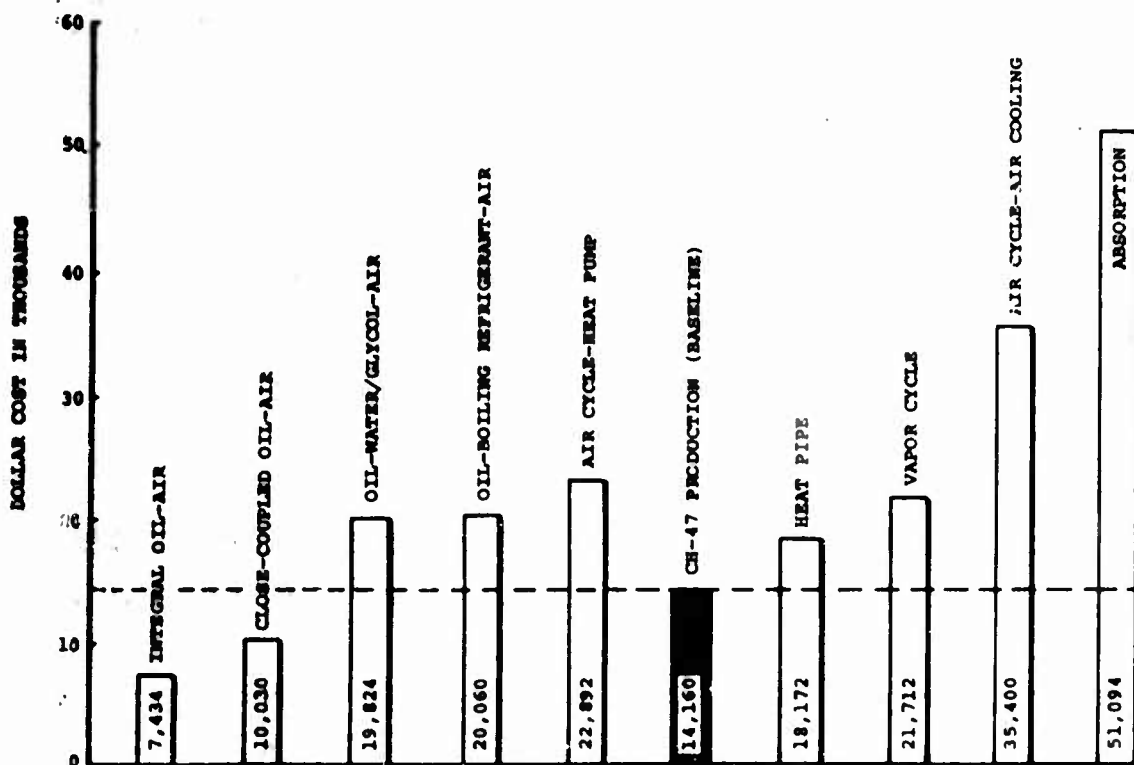

Figure 13. Equivalent Weight Rating

MISSION WEIGHT DETERMINATION

In order to establish a value for the rating of equivalent weight, it was decided to use the CH-47C helicopter, performing an Army mission at 3,000 feet pressure altitude and 90°F atmospheric temperature, as a baseline. The mission description is as follows:

1. Warm up 2 minutes at normal rated power
2. Take off and cruise outbound 100 nautical miles
3. Land and exchange payload (inbound payload = 1/2 outbound payload)
4. Warm up 2 minutes at normal rated power
5. Take off and cruise inbound 100 nautical miles
6. Land with 10 percent fuel reserve

The mission weight, fuel, and speed are:

Maximum gross weight based on hover out-of-ground effect at 3,000 feet, 90°F:

20,420 pounds empty weight (unmodified)
873 pounds added by New Cumberland maintenance work orders
1,369 pounds Vietnam combat equipment
22,662 pounds empty weight (modified for Vietnam)

Empty weight	22,662 pounds
Fixed useful load	689 pounds
Fuel	<u>4,209</u> pounds
Total aircraft weight	<u>27,560</u> pounds

Maximum gross weight	42,200 pounds
Minus total aircraft weight	<u>27,560</u> pounds
Payload out	<u>14,640</u> pounds

Payload out = 14,640 pounds
Average speed out = 137 knots

Payload in = 7,320 pounds
Average speed in = 153 knots

Approximate average payload = 10,980 pounds
Approximate average speed = 145 knots

EQUIVALENT WEIGHT RATING (Figure 13)

In an effort to relate weight to cost, it was decided to find the total system operating equivalent weight for the present CH-47 and to relate this to its percentage of the average payload of 10,980 pounds. This percentage multiplied

by the cost of an aircraft will indicate how many theoretical aircraft would have to be purchased due to the loss of payload caused by the forward transmission oil cooling system weight. Since the present blower delivers its total output to four oil coolers using approximately the same amount of air, the weight and horsepower of the present blower were apportioned by a factor of 4.

CH-47 Production System Weight Breakdown

	<u>Pounds</u>
System dry weight	69.0
Oil weight	21.1
System operating weight	<u>90.1</u>
System hp = 4.2 x 7 lb/hp equivalent weight	29.9
Total system operating equivalent weight	120.0

Payload without cooling system = 10,980 + 120 = 11,100 lb

Weight-cost index per pound = $\frac{\$1,310,000}{11,100 \text{ lb}} = \$118/\text{lb}$

Based on the \$118/lb weight-cost index, the following costs are attached to the two sample systems.

	<u>CH-47 Production System</u>	<u>Close-Coupled Oil-Air System</u>
Total system operating equivalent weight	120 lb	85 lb
At \$118/lb	120 x \$118 = \$14,160	85 x \$118 = \$10,030
Weight rating	\$14,160	\$10,030

RELIABILITY RATING (Figure 14)

System reliability rates will be based on present failure rates of typical components in helicopter operation. As with the other ratings, the present CH-47 production forward transmission oil cooling system is used as a baseline. All failure rate information will be based on an aircraft life of 6,000 flight hours over a period of 10 years. The reliability ratings for the two sample forward transmission oil cooling systems are summarized in Tables IV and ..

MAINTAINABILITY RATING (Figure 15)

The approximate time in man-minutes required to maintain the CH-47 production forward transmission oil cooling system and the close-coupled oil-air system are shown in Tables VI and VII. These figures are approximate; however,

TABLE IV. CH-47 PRODUCTION SYSTEM RELIABILITY RATING					
Component	Failures in 6,000 Hours	Total Component Cost (dollars)	Total Man-Hours	Man-Hour Cost at \$6/Hour (dollars)	Total Cost (dollars)
Oil Pump	5.3	2,253	5.3	32	2,285
Oil Filter	10.5	1,764	10.5	63	1,827
Oil Cooler	0.2	142	0.4	2	144
Oil Lines	18.2	326	36.2	217	543
Oil Hoses	10.4	374	20.8	125	499
Blower Shaft	0.9	41	1.8	11	52
Blower	0.05	7	0.1	1	8
Total CH-47 Production System Reliability Rating					\$5,358

TABLE V. CLOSE-COUPLED OIL-AIR SYSTEM RELIABILITY RATING					
Component	Failures in 6,000 Hours	Total Component Cost (dollars)	Total Man-Hours	Man-Hour Cost at \$6/Hour (dollars)	Total Cost (dollars)
Oil Pump	5.3	2,252	5.3	32	2,286
Oil Filter	10.5	1,764	10.5	63	1,827
Oil Cooler	0.2	142	0.4	2	144
Oil Lines	5.2	94	10.4	62	156
Oil Hoses	5.2	187	10.4	62	249
Drive Belt	9.0	90	4.5	27	117
Blower	0.2	30	0.4	2	32
Pillow Blocks	4.2	126	8.4	50	176
Exhaust	0.8	8	0.8	5	13
Total Close-Coupled Oil-Air System Reliability Rating					\$5,000

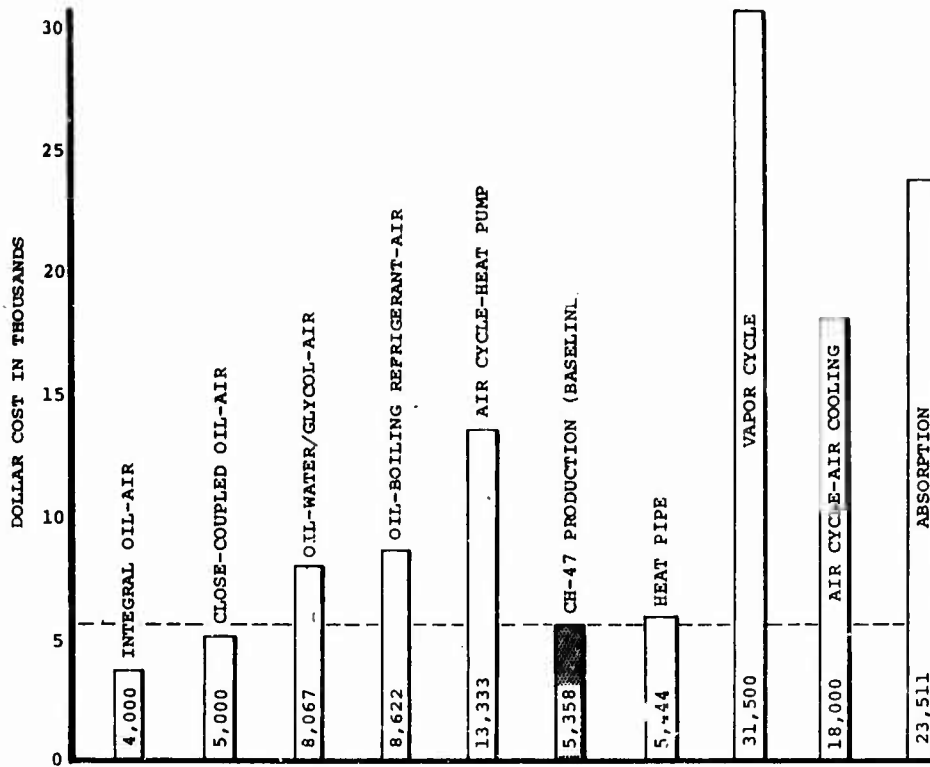

Figure 14. Reliability Rating

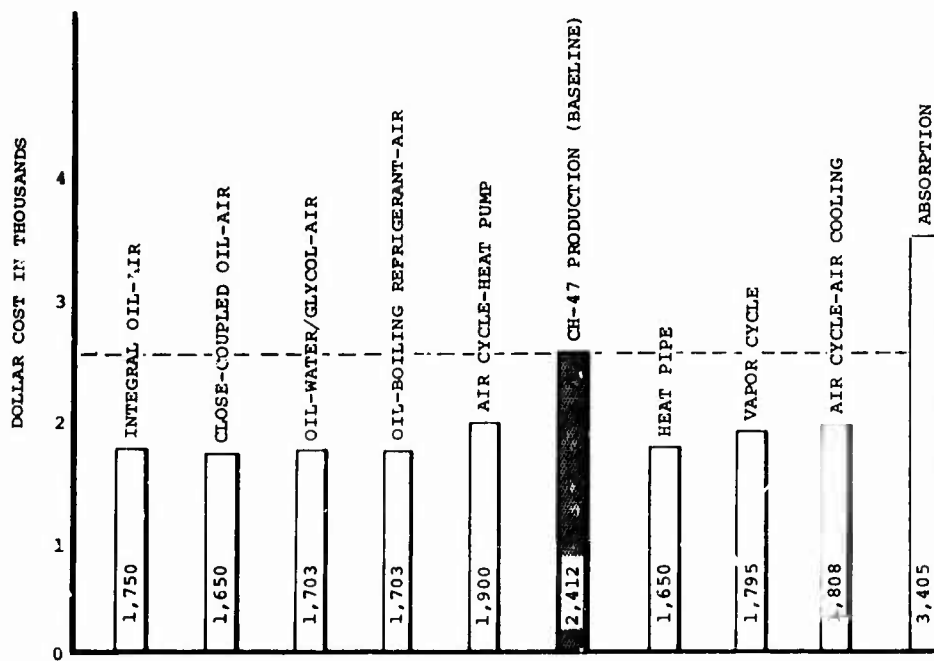

Figure 15. Maintainability Rating

TABLE VI. CH-47 PRODUCTION SYSTEM MAINTAINABILITY RATING			
Task Description	Approximate Time (man-minutes)	10-Year Frequency	10-Year Total (man-minutes)
Daily Inspection	5	3,353	16,765
Intermediate Inspection (25 hours)	10	240	2,400
Periodic Inspection (100 hours)	15	60	900
Grease Fan (every other intermediate)	4	120	480
Clean Oil Filter (25 hours)	15	240	<u>3,600</u>
		Total Man-Minutes	24,145
		Total Man-Hours	402
Total CH-47 Production System Maintainability Rating			= 402 x \$6.00 = \$2,412

TABLE VII. CLOSE-COUPLED OIL-AIR SYSTEM MAINTAINABILITY RATING			
Task Description	Approximate Time (man-minutes)	10-Year Frequency	10-Year Total (man-minutes)
Daily Inspection	3	3,353	10,059
Intermediate Inspection (25 hours)	7	240	1,680
Periodic Inspection (100 hours)	9	60	540
Grease Fan (every other intermediate)	5	120	600
Clean Oil Filter (25 hours)	15	240	<u>3,600</u>
		Total Man-Minutes	16,479
		Total Man-Hours	275
Total Close-Coupled Oil-Air System Maintainability Rating			= 275 x \$6.00 = \$1,650

it is felt that they are representative of the actual conditions. The times are broken down into the various maintenance levels, and specific tasks are identified where necessary. A rate of \$6.00 per hour was chosen as being representative of U.S. Army labor and overhead costs. All figures are based on a maximum of 6,000 flight hours in 10 years.

COST RATING (Figure 16)

System cost ratings are based on approximate hardware costs, using the CH-47 production forward transmission oil cooling system as a baseline. The costs shown are average and will vary accordingly with the number of units purchased and the time frame in which purchases are made. Detailed cost rating breakdowns for the CH-47 production forward transmission oil cooling system and for the close-coupled oil-air system are shown in Tables VIII and IX.

TOTAL SYSTEM RATING

The total system rating consists of the summation of the various individual ratings. It is obvious that the system with the lowest total rating will be the most ideal, while that system with the highest rating will be the least desirable.

Various factors for each system studied are shown and compared in Figure 17 and Table X.

TABLE VIII. CH-47 PRODUCTION SYSTEM COST RATING

Component	Quantity	Approximate Cost (dollars)
Oil Pump	1	425
Oil Filter	1	168
Oil Cooler	1	712
Oil Lines	7	123
Oil Hoses	4	145
Blower Shaft	1/4	45
Blower	1/4	130
Miscellaneous Hardware	-	52
Total CH-47 Production System Cost Rating \$1,800		

TABLE IX. CLOSE-COUPLED OIL-AIR SYSTEM COST RATING

Component	Quantity	Approximate Cost (dollars)
Oil Pump	1	425
Oil Filter	1	168
Oil Cooler	1	712
Oil Lines	2	35
Oil Hoses	2	73
Drive Belt	1	10
Blower Fan	1	150
Pillow Blocks	2	60
Exhaust Duct	1	10
Miscellaneous Hardware	-	62
Total Close-Coupled Oil-Air System Cost Rating \$1,705		

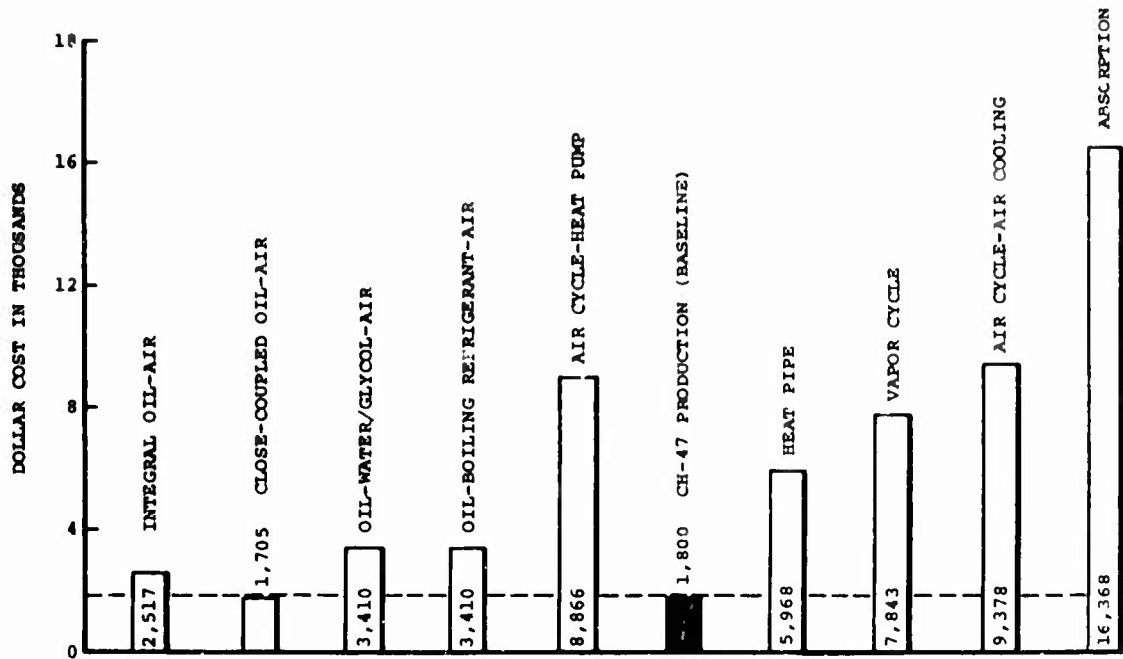

Figure 16. Cost Rating.

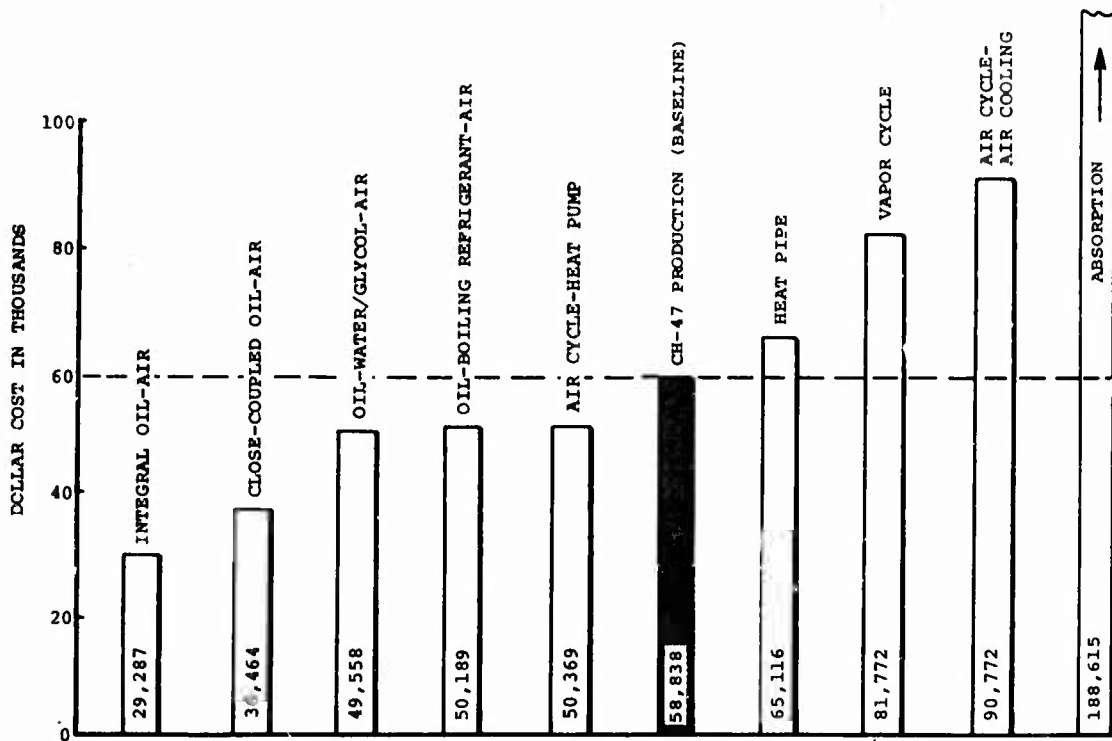

Figure 17. Total System Rating

TABLE X. DOLLAR SUMMARY OF SYSTEM COST-EFFECTIVENESS RATINGS*							
System Description	Vulnerability Rating	Weight Rating	Reliability Rating	Maintainability Rating	Cost Rating	Total System Rating	
Integral Oil-Air	13,586	7,434	4,000	1,750	2,517	29,287	
Close-Coupled Oil-Air	18,079	10,030	5,000	1,650	1,705	36,464	
Oil-Water/Glycol-Air	16,554	19,824	8,067	1,703	3,410	49,558	
Oil-Boiling Refrigerant-Air	16,394	20,060	8,622	1,703	3,410	50,189	
Air Cycle-Heat Pump	3,378	22,892	13,333	1,900	8,866	50,369	
CH-47 Production	35,108	14,160	5,358	2,412	1,800	58,838	
Heat Pipe	33,882	18,172	5,444	1,650	5,968	65,116	
Vapor Cycle	18,922	21,712	31,500	1,795	7,843	81,772	
Air Cycle-Air Cooling	26,186	35,400	18,000	1,808	9,378	90,772	
Absorption	94,237	51,094	23,511	3,405	16,368	188,615	

* Based on 1 aircraft out of a fleet of 250, flying 50 hours per month for 10 years.

DESIGN CONSIDERATIONS

OIL COOLER VOLUME

1. Reductions in oil cooler volume can be attained with increased system input power, which is used for higher induced air and/or secondary coolant flow rates and for increased blower, pump, and compressor pressure ratios.
2. A recirculating secondary fluid yields oil cooler volumes considerably smaller than systems using an air heat sink.
3. A minimum-oil-cooler-volume system is characterized by excessive system equivalent weight.
4. Location of the blower in a close-coupled, oil-air heat exchanger system downstream of the heat exchanger is approximately 3 to 5 percent more cost effective from an overall system standpoint than an upstream location; i.e., it is better to force air through the cooler than to draw it through.

SYSTEM INSTALLED WEIGHT

1. Minimum-weight systems are obtained with a fan and an oil-air heat exchanger.
2. A reduction in system hardware weight can be obtained by using increased power inputs.

SYSTEM POWER AND EQUIVALENT WEIGHT

1. Higher input power results in substantial increases in system equivalent weight based on a 7-pound-per-horsepower weight equivalency.
2. A minimum-equivalent-weight system will not result in minimum vulnerability, since the oil cooler volume becomes prohibitive.

SYSTEM VOLUME

1. A minimum-volume system is obtained with an integral oil-air heat exchanger and blower.
2. System volume can be reduced by the use of increased power.

SYSTEM RELIABILITY

1. Maximum system reliability will be obtained by using an oil-air heat exchanger and blower arranged to reduce complexity and number of components to a minimum.

2. The reliability of mechanically driven blowers deteriorates rapidly above approximately 10,000 rpm.

SYSTEM MAINTAINABILITY

Minimum system maintainability will be achieved with a compact oil-air heat exchanger and blower system, since inspection and maintenance will be localized.

SYSTEM COST

The minimum-cost system will be an oil-air system employing a rectangular oil cooler with a compact system arrangement.

COST-EFFECTIVENESS VALUE

For initial preliminary design purposes, it is important to realize the approximate value as it influences cost effectiveness for each of the systems studied. This approximate value is the percentage of the total cost figure of the various rating parameters and the contribution or effect each of these parameters has on overall system cost effectiveness. The approximate ranges are shown in Table XI.

TABLE XI. RANGES OF COST-EFFECTIVENESS VALUE		
Rating Parameter:	All Types of Cooling Systems (percent)	Conventional Oil-Air System (percent)
Vulnerability - Volume, in. ³ (2 x A-kill + 1 x B-kill)	20-60	50
Equivalent Weight, lb (Hardware + 7 x hp)	25-50	27
Reliability	10-40	12
Maintainability	2-7	5
Component Cost	3-15	6

From these figures it can be seen that, for most designs, the two most important parameters are system vulnerable volume and equivalent weight. Reliability should also be considered in the final design stages.

DEVELOPMENT PROBLEMS

INTEGRAL OIL-AIR SYSTEM

1. Reasonable system development costs
2. Anticipated development problems:
 - a. Annular oil cooler construction
 - b. Space restrictions

CLOSE-COUPLED OIL-AIR SYSTEM

1. Minimal system development cost
2. Anticipated development problems: None

OIL-WATER/GLYCOL-AIR SYSTEM

1. Reasonable system development costs
2. Logistic handling (secondary coolant fluid)

Field replacement of secondary fluid: for emergency use, other fluids may be used at reduced cooling capacity.
3. Anticipated development problems: None

OIL-BOILING REFRIGERANT-AIR SYSTEM

1. Reasonable system development costs
2. Logistic handling (refrigerant)

Field replacement must be a similar-type refrigerant.
3. Anticipated development problems:

Gerotor pump seal: seal design must insure essentially zero refrigerant leakage and acceptable lubricant recirculation.

AIR CYCLE-HEAT PUMP SYSTEM

1. High initial development cost to insure compatibility of speed variation with air cycle machine characteristics
2. Anticipated development problems:

- a. Maintain acceptable size levels
- b. Possible requirement for anti-ice and antisurge controls for off-design-point operation
- c. Air cycle machine containment design requirements
- d. System performance variation with air cycle machine at off-design-point operation
- e. Gearing for air cycle machine drive system: air cycle machine hot-day speed in excess of 40,000 rpm

HEAT PIPE SYSTEM

- 1. High initial tooling costs for fin tube (condenser) assembly
- 2. Logistic handling of secondary fluid: None
- 3. Anticipated development problems:
Aircraft installation complexity due to large number of heat pipes (260) and total system volume

VAPOR CYCLE SYSTEM

- 1. Logistic handling of refrigerant
- 2. Anticipated development problems:
 - a. Aircraft installation is complex due to large system volume.
 - b. Design must minimize potential sources of refrigerant leakage.
 - c. During off-design-point operation, i.e., considerably below 125°F atmospheric temperature, a condenser control may be required to maintain condenser pressure above evaporator pressure to insure system stability and delivery of net transmission oil cooling.
 - d. Refrigerant compressor drive shaft seal: design must insure essentially zero refrigerant leakage and acceptable lubrication recirculation.

AIR CYCLE-AIR COOLING SYSTEM

- 1. High initial development cost to insure compatibility of air cycle machine characteristics
- 2. Anticipated development problems:

- a. Maintain acceptable noise levels
- b. Possible requirements for anti-ice and antisurge controls for off-design-point operation
- c. Air cycle machine containment design requirements
- d. System performance variation with air cycle machine speed at off-design-point operation
- e. Gearing for air cycle machine drive system: air cycle machine hot-day speed in excess of 40,000 rpm

ABSORPTION SYSTEM

- 1. High initial development costs
- 2. Logistic handling of refrigerant (ammonia)
- 3. Aircraft installation complexity due to excessive system volume
- 4. System working fluid must be compatible with aircraft toxicity requirements
- 5. System design must insure minimal refrigerant leakage; effective seal design is a problem
- 6. Anticipated development problems: None

DETAILED PRELIMINARY SYSTEM LAYOUTS

The following systems, which are applicable to the CH-47 forward transmission and which indicate improvement over the production system with regard to vulnerability and cost effectiveness, are presented in Figures 18 through 26:

1. Integral oil-air system
2. Close-coupled oil-air system
3. Close-coupled oil-water/glycol-air system
4. Close-coupled oil-boiling refrigerant-air system

These installation drawings show the airframe space restrictions for the systems. In general, these systems can be installed within the available space with a minimum amount of modification.

DETAILS

1 **OIL COOLER** WEIGHT 17.5 LB DRY
 22.5 LB WET
 CORE VOLUME 6.51 CU IN
 TOTAL VOLUME 72.0 CU IN
 CAPACITY 1.200 BTU/WH
 AIR PRESSURE DROP 5.7 IN H₂O

2 **BLOWER** AIRFLOW 140 LB /MIN
 STATIC PRESSURE 0.5 IN H₂O
 RPM 2080

3 **PARTS DELETED FROM
 (OATC FORWARD)
 TRANSMISSION**

ITEM	WT (LB)
RIBBED HOUSING	57.2
OIL PUMP	6.2
OIL FILTER	2.6
SCRAAP ASSEMBLY (INCL OIL DETECTOR)	12.5

**NEW PARTS REQUIRED
 FOR THIS CONFIGURATION**

ITEM	WT (LB)
RIBBED HOUSING	55.3
(WITHOUT OIL PUMP)	
SUPPORT SECTION	
GENERATOR PUMP	1.0
FILTER (OIL)	2.6
COOLER ASSEMBLY	17.5
PUMP DRIVE GEARS	5.1
SUN GEAR (3.0 LARGER)	2.5
BEARINGS (2)	1.0
BUSHINGS (2)	1.0
BLUISH IMPELLER	1.0
SCRAAP	1
BEARINGS ATTACHED (END (AP) PUMP)	
LUBRICANTS (3)	1.0
PRE PACKED BANG SEALS	
BEARINGS LOWER	
OIL DETECTOR	
NEW SCRAAP	10.5
OIL LINES & FITTINGS	2
APPROXIMATE WEIGHT (WT) FOR 4	

APPROXIMATE WEIGHT REMAIND 77.6

TOTAL WEIGHT (APPROX) 246 LB

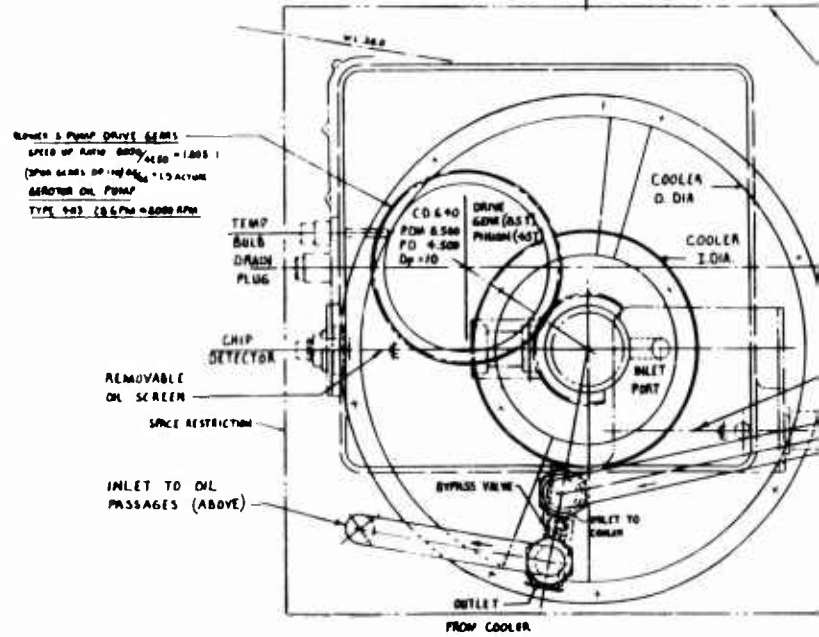
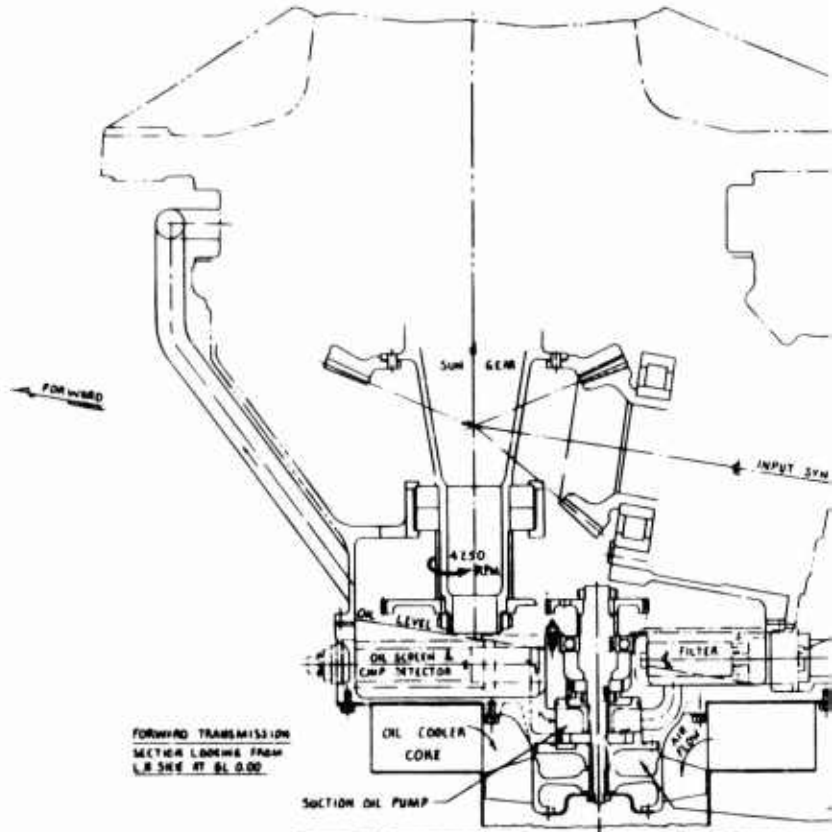

A

Figure 18. Centerline Section of Integrally Cooled Transmission.

B DRY
 B WET
 SI CU IN.
 EO CU IN.
 BTU/MIN
 P 5.7 IN. H₂O
 /MIN
 1.5 IN. H₂O

NEW PARTS REQUIRED FOR THIS CONFIGURATION.

ITEM	WT (LBS)
RIBBED HOUSING (WITHOUT OIL PUMP)	53.5
(SUPPORT SECTION)	
GEARBOX PUMP	1.0
FILTER (OIL)	2.6
COOLER ASSEMBLY	17.5
PUMP DRIVE GEARS	5.1
SUN GEAR (COLONER)	2.5
BEARINGS (2)	1.0
BUSHINGS (2)	1.0
BLOWER IMPELLER	1.0
SPACER	1
BEARING RETAINER (NO CAP (PUMP))	1.0
LOCKWASHERS (3)	
PRE-POURED RING SEALS	
BEARING LINER	10.5
CHIP DETECTOR	
NEW SUMP	3.6
OIL LINES & FITTINGS	
APPROXIMATE WEIGHT (DRY) 102.4	

TOTAL INCREASE (APPROX) 24.6 LBS

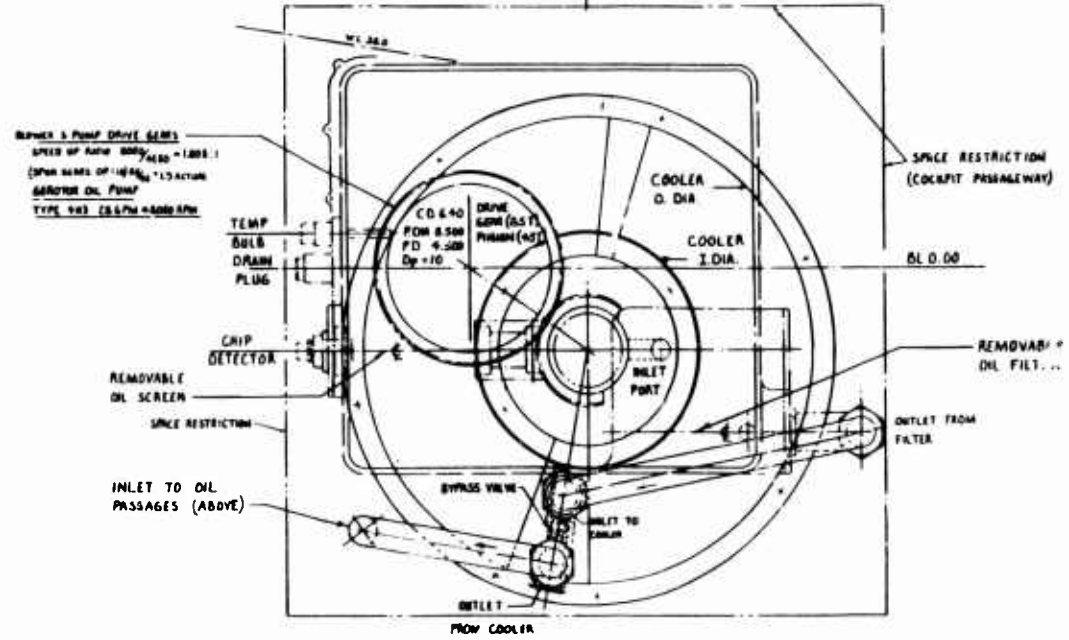
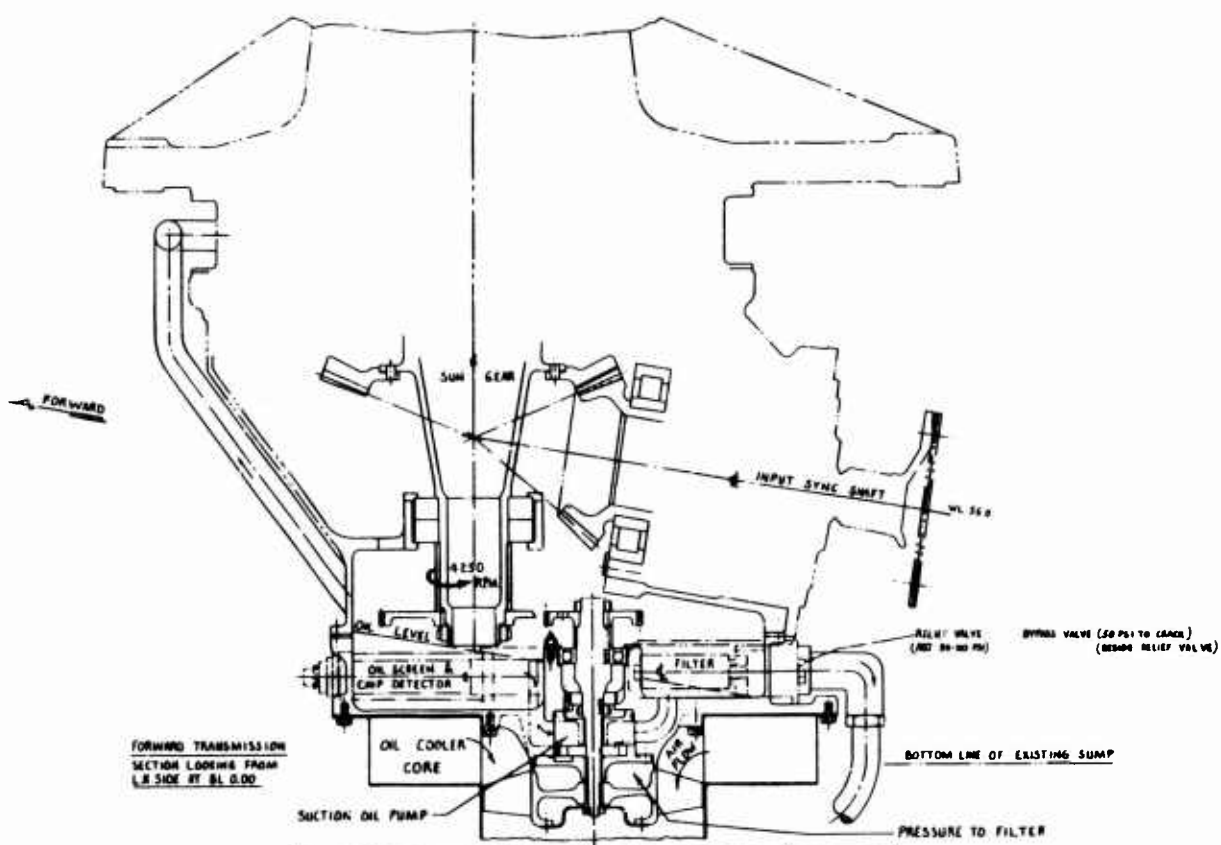

Centerline Section of Integrally Cooled Transmission.

B

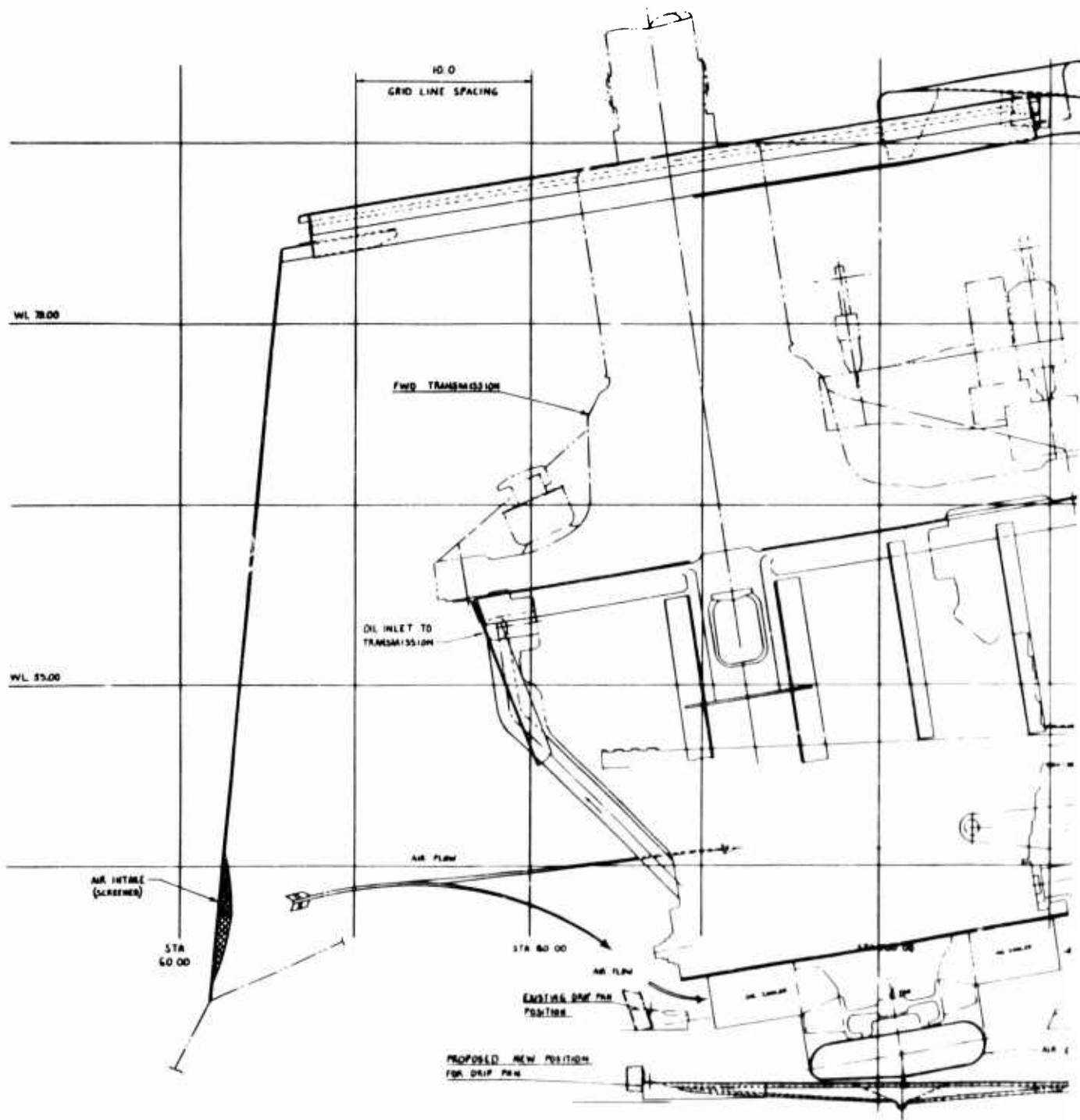

A

Figure 19. Integral Oil-Air System Layout.

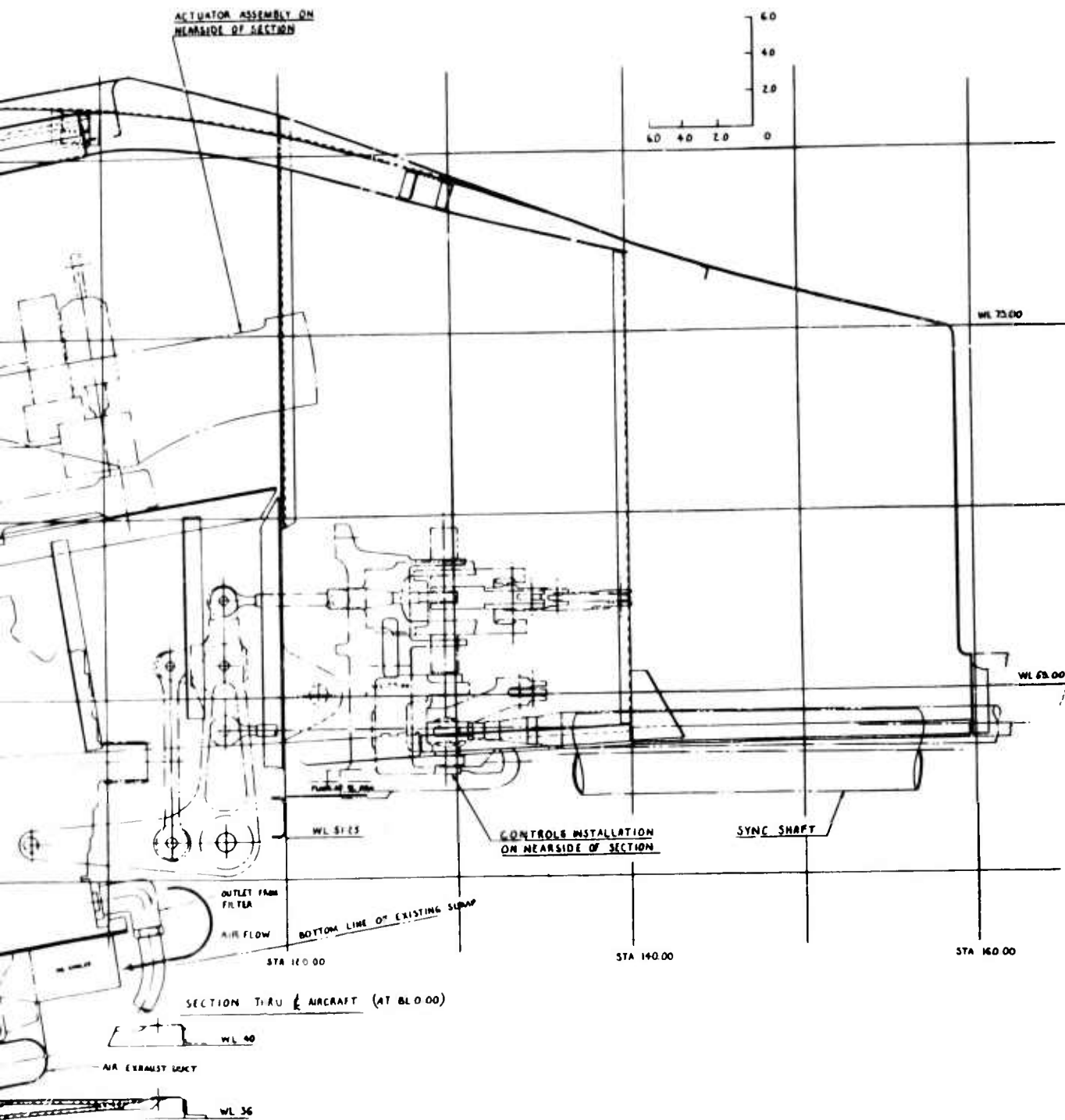

B

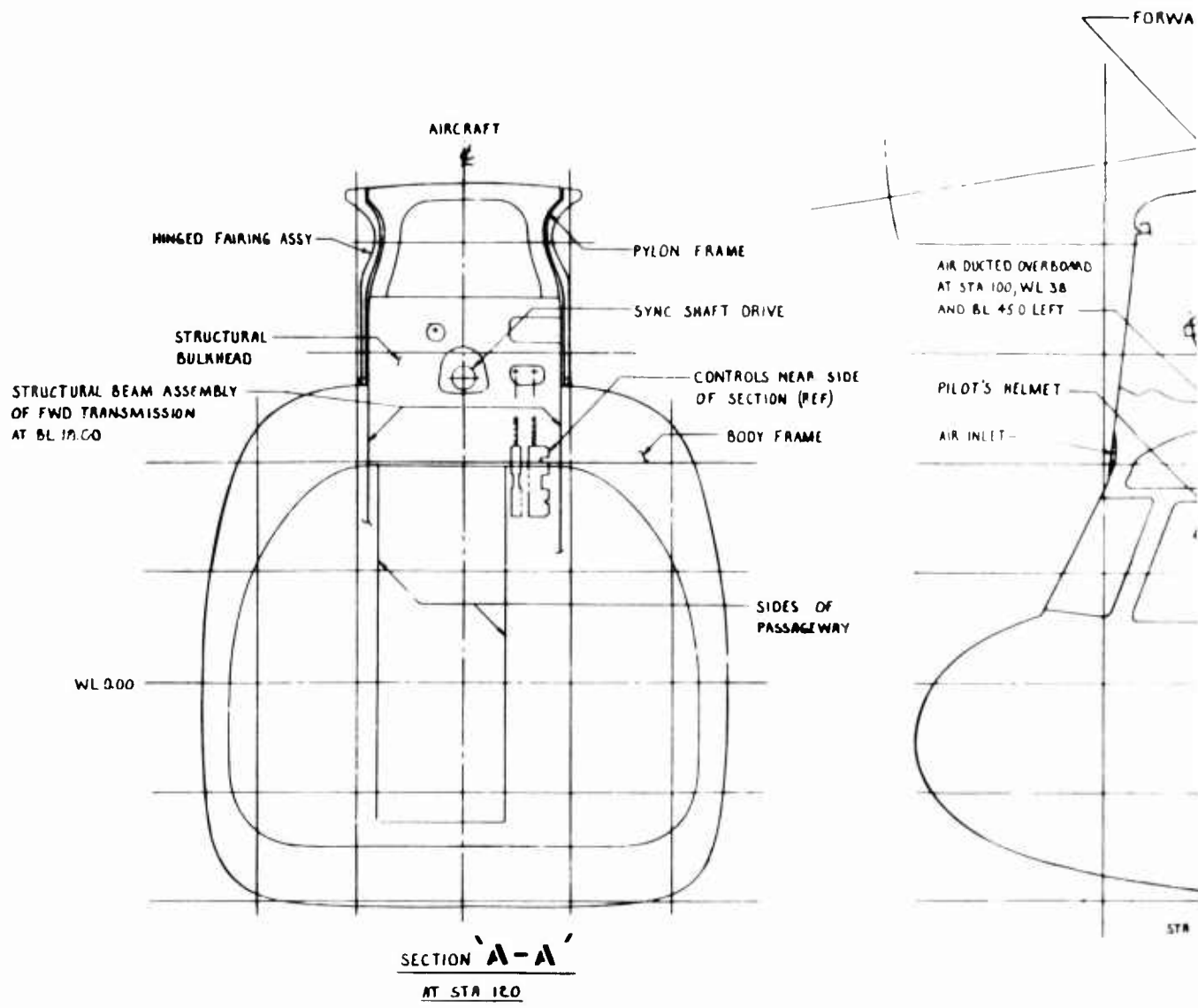
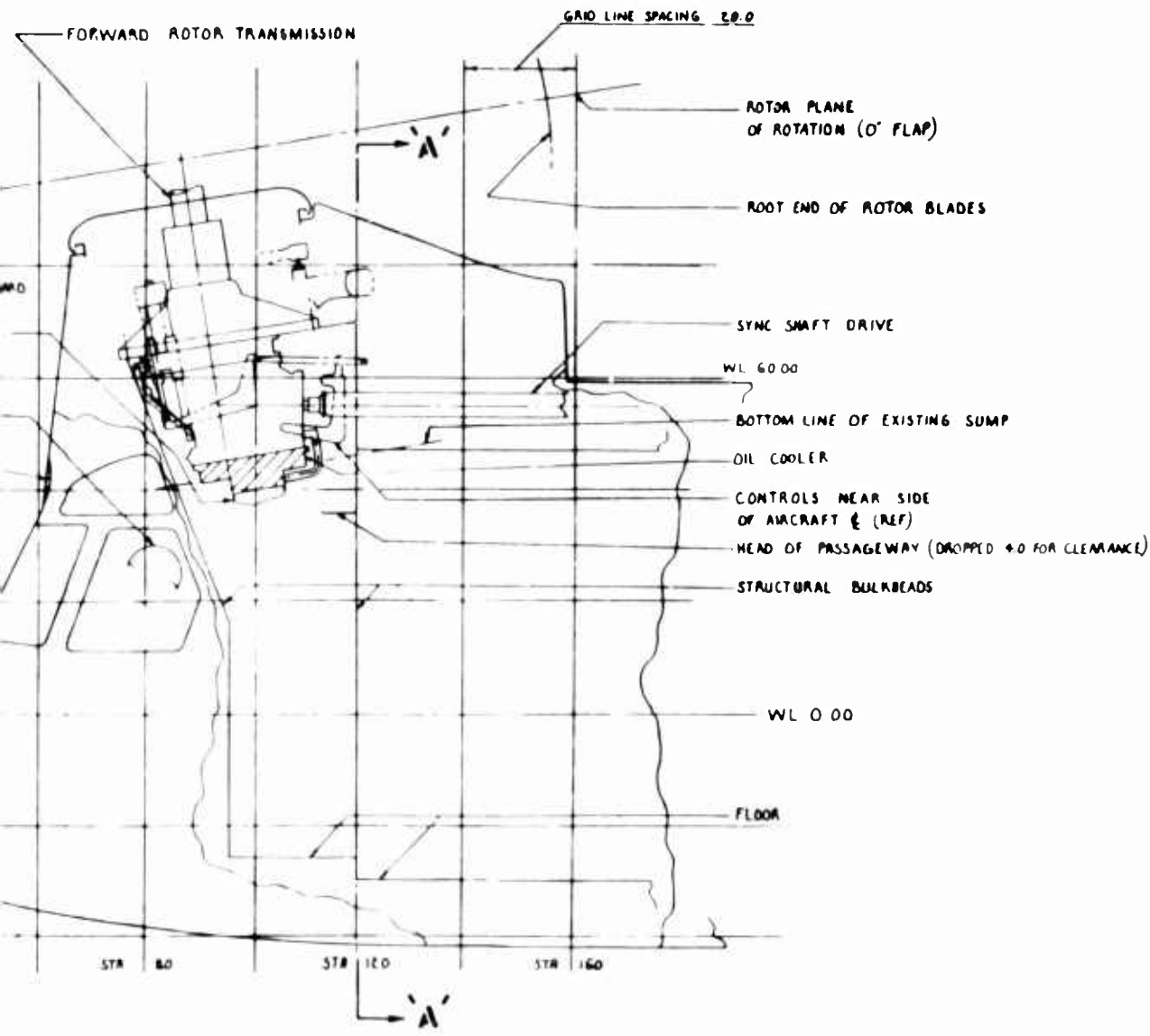
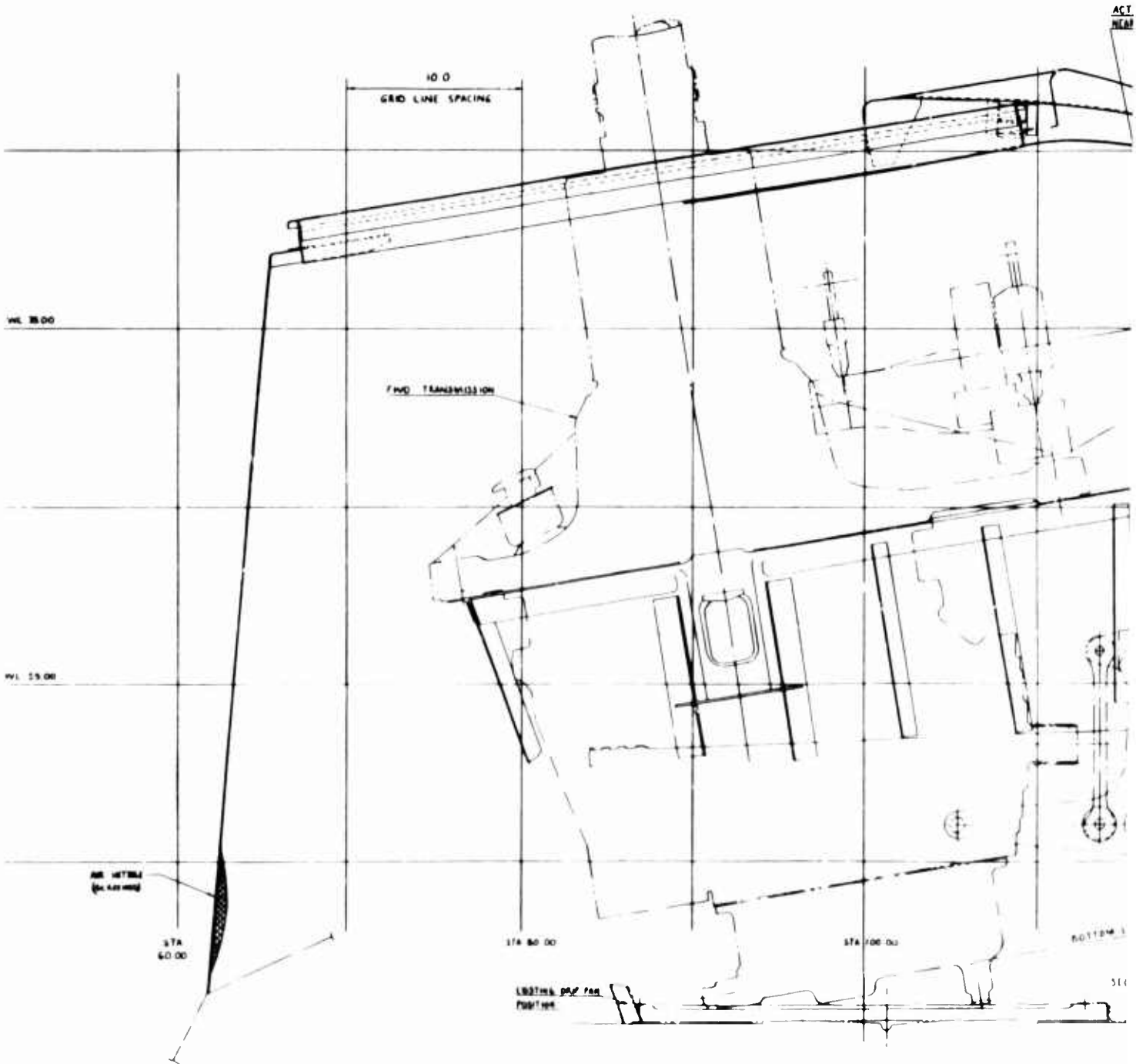

Figure 20. Integral Oil-Air System.

A



B



A

Figure 21. Close-Coupled Oil-Air System Layout.

ACTUATOR ASSEMBLY ON
NEAR SIDE OF SECTION

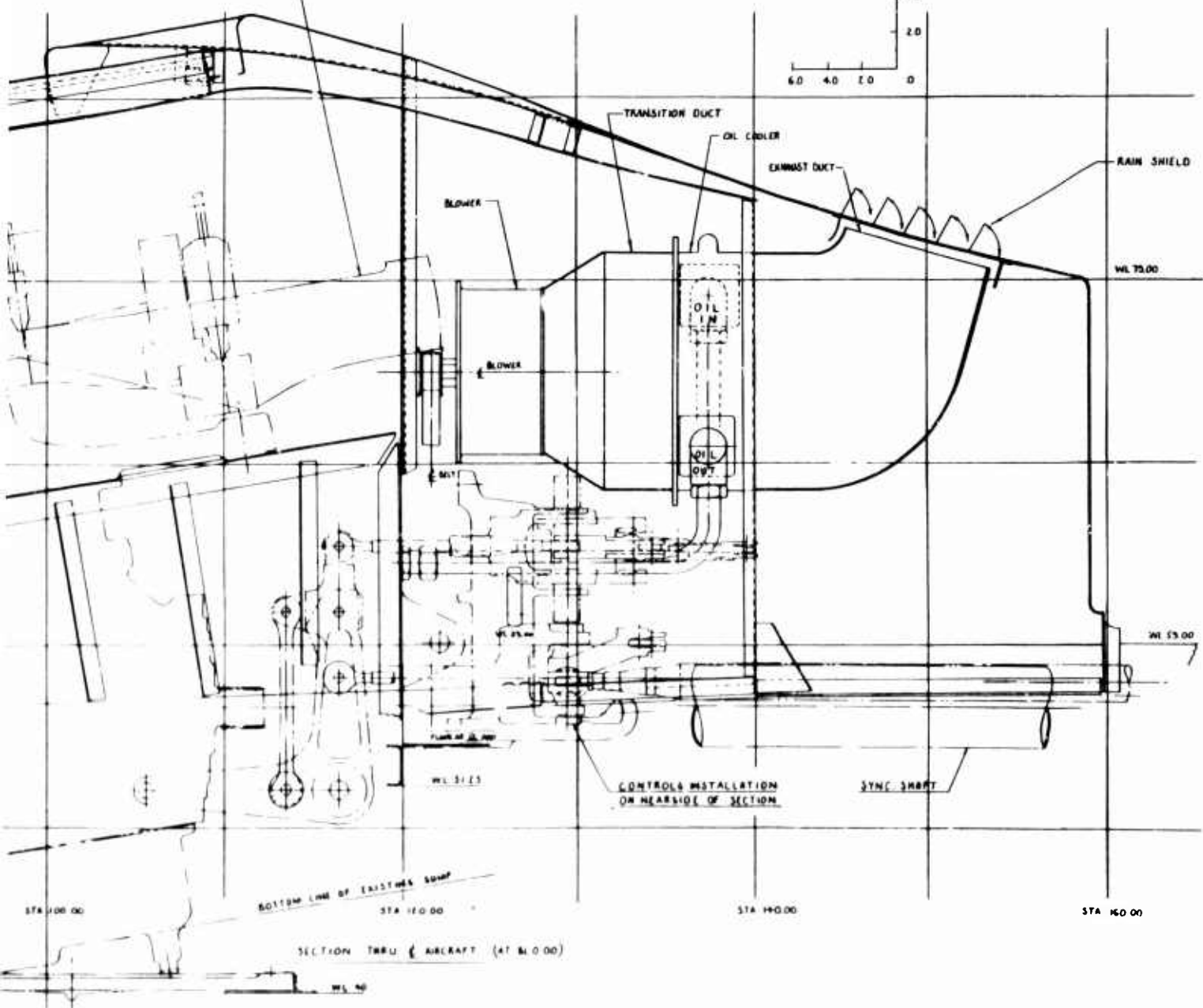
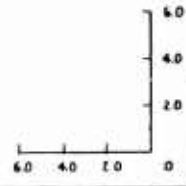

B

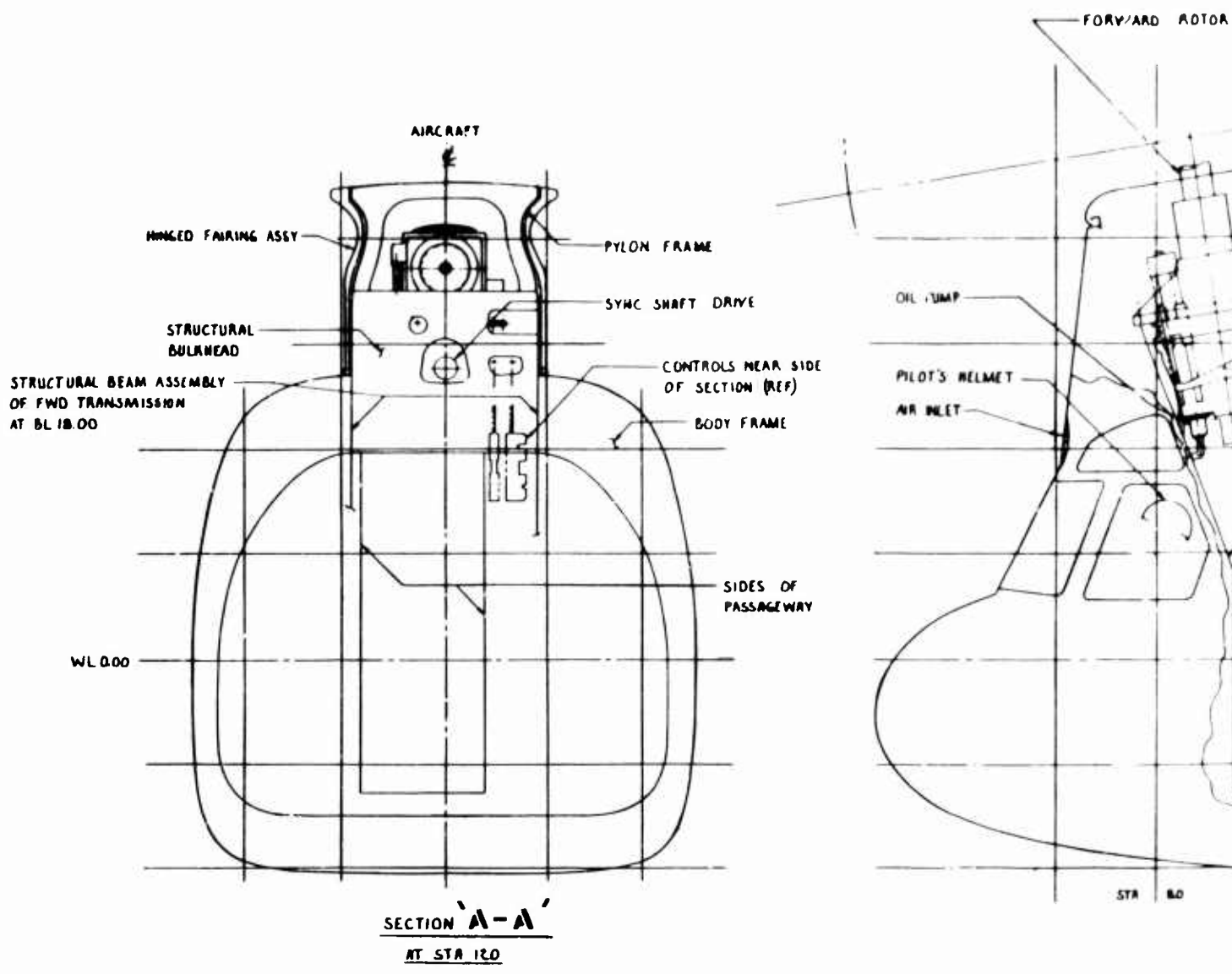
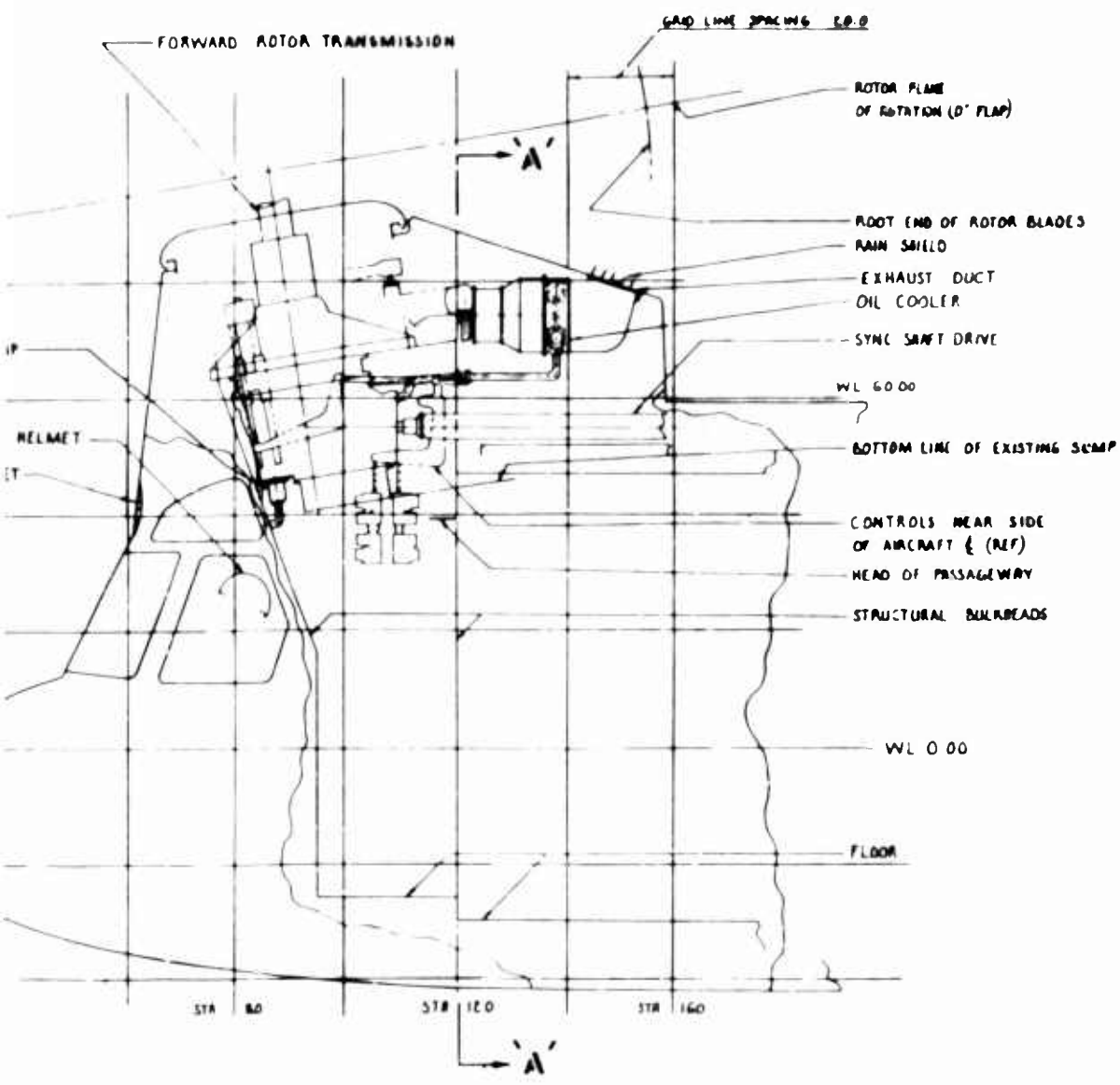
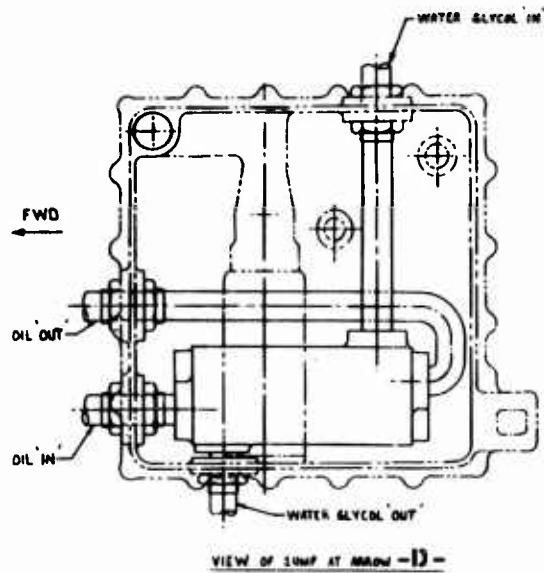

Figure 22. Close-Coupled Oil-Air System.

A



B



NOTES

PARTS DELETED FROM CS-43C FORWARD TRANSMISSION	
ITEM	WT. (LB)
OIL SUMP	12.5
OIL PUMP	5.2

APPROX WT. REMOVED 17.7

NEW PARTS REQUIRED FOR THIS CONFIGURATION	
ITEM	WT. (LB)
NEW OIL SUMP	17.5
OIL/WATER GLYCOL PUMP	8.3
OIL COOLER (DRY)	6.1
INTERNAL OIL AND WATER GLYCOL LINES AND FITTINGS	4.1

APPROX WT. DRY 36.0
TOTAL INCREASE 20.3 LB (APPROX)

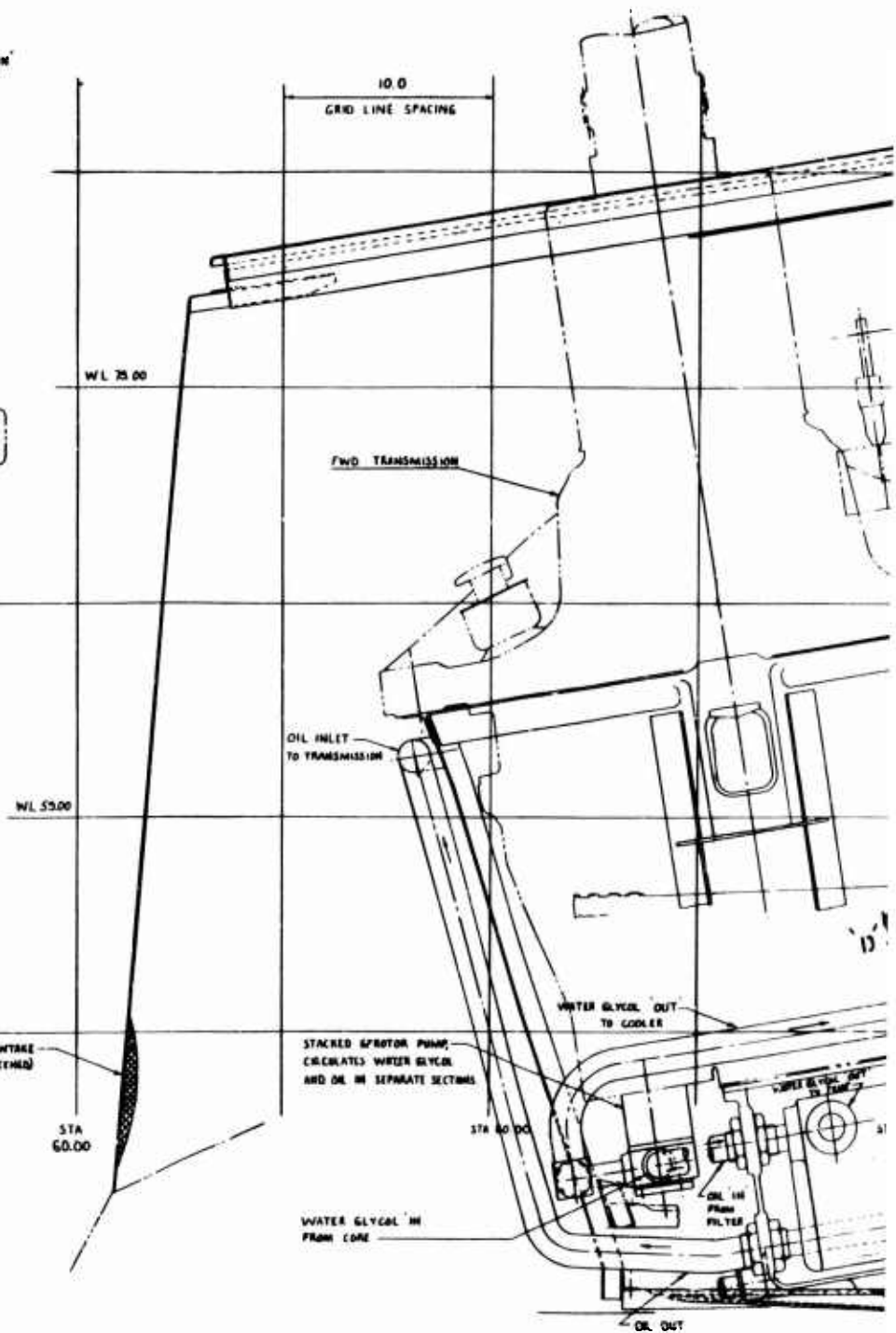

A

Figure 23. Oil-Water/Glycol-Air System Layout.

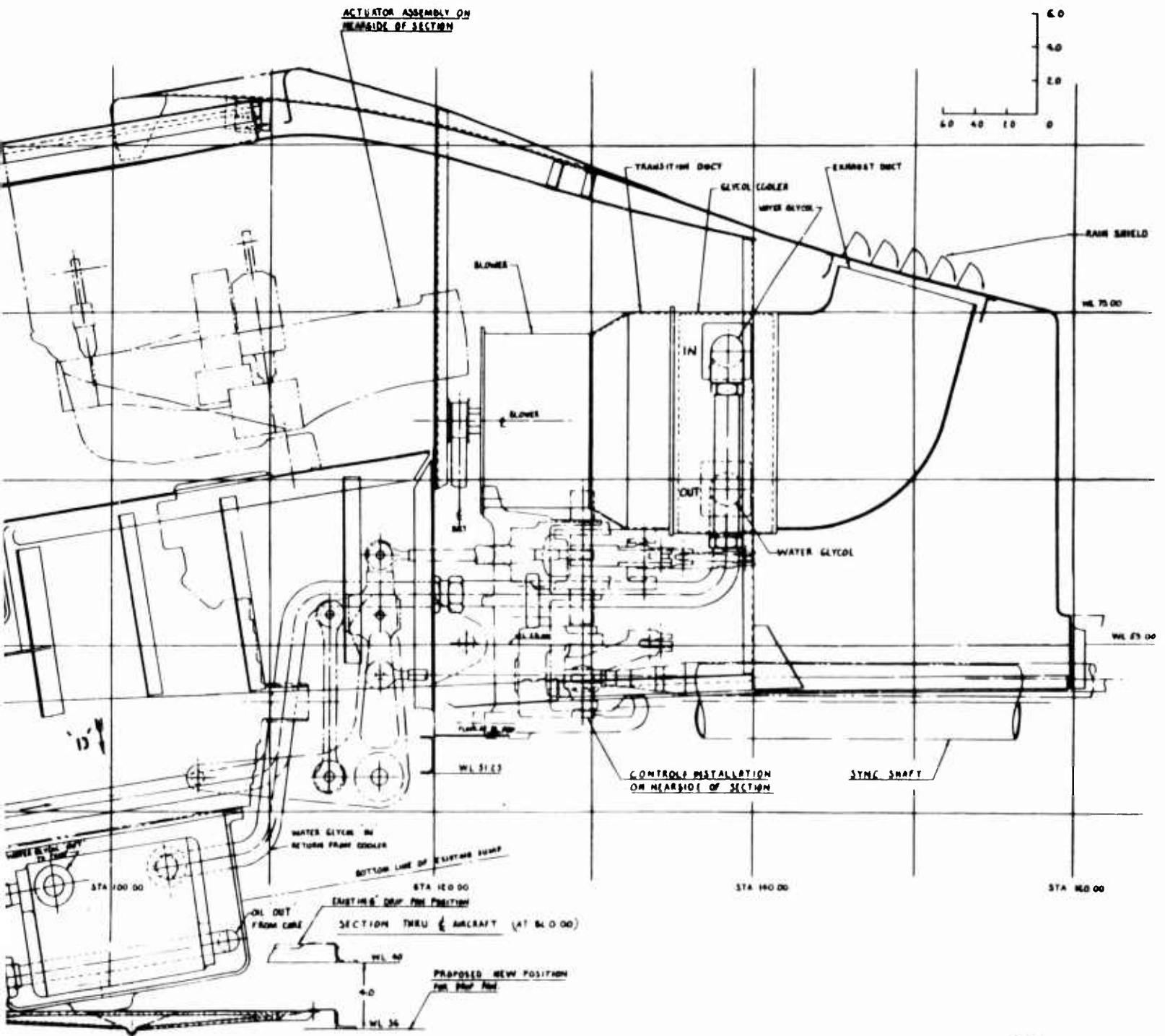

B

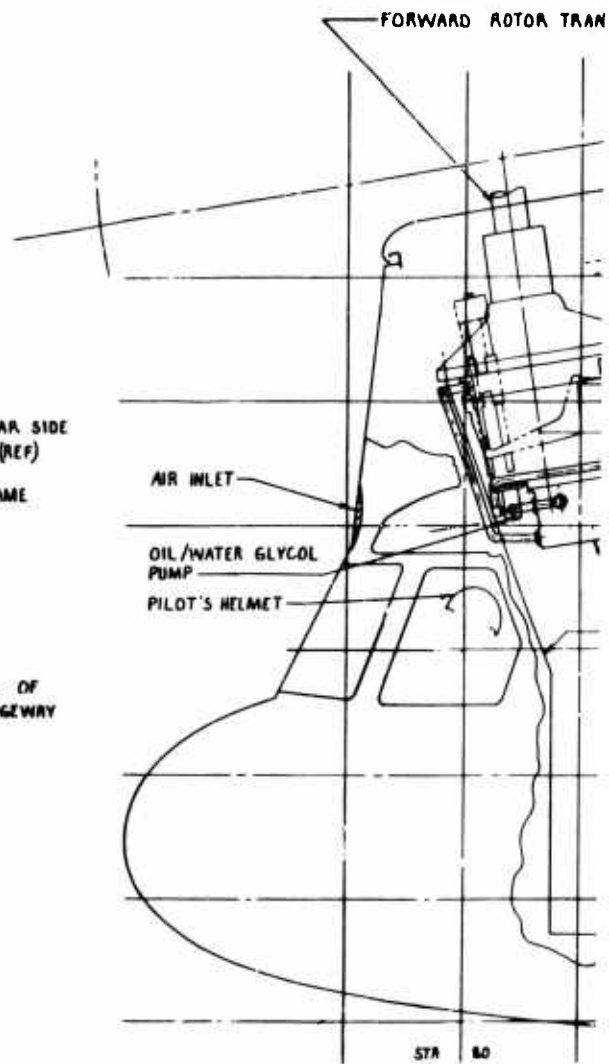
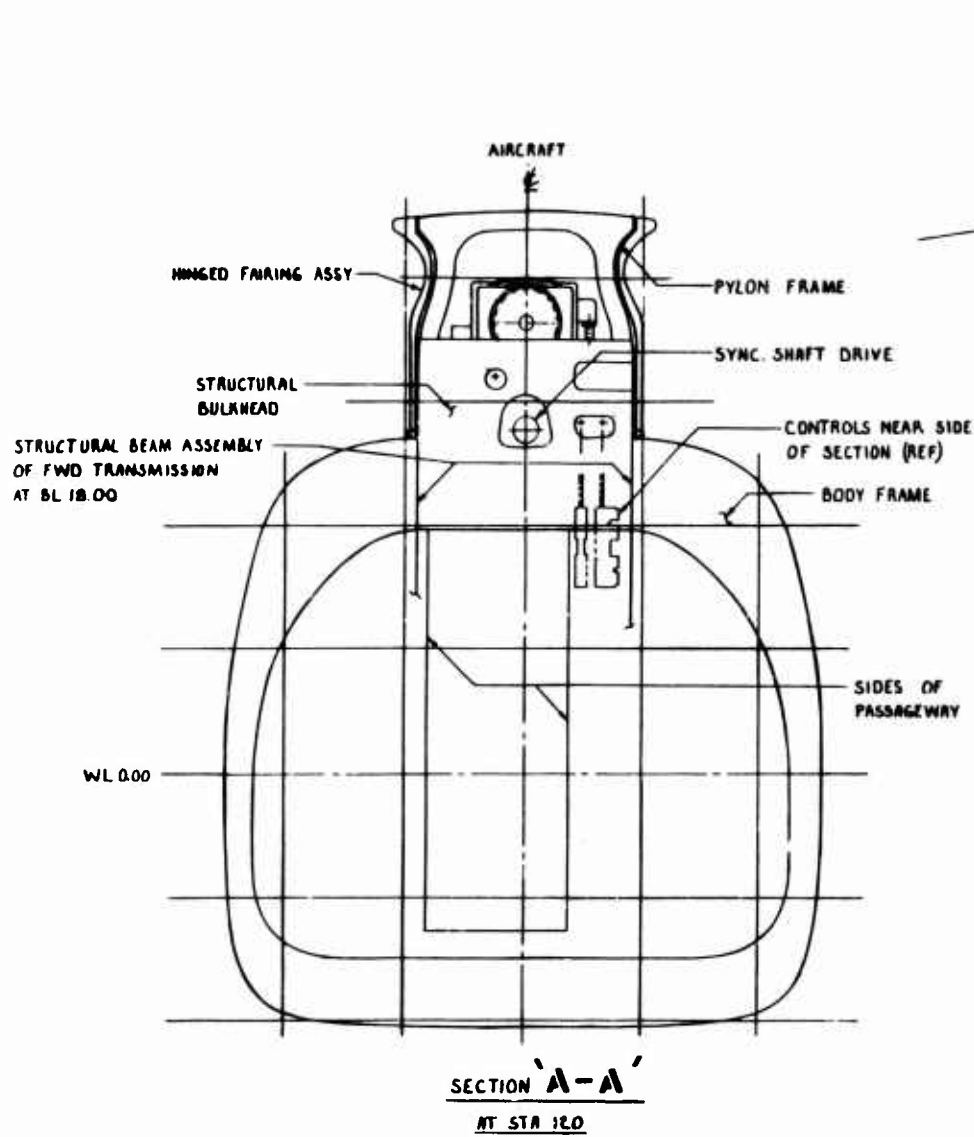

A

Figure 24. Oil-Water/Glycol-Air System.

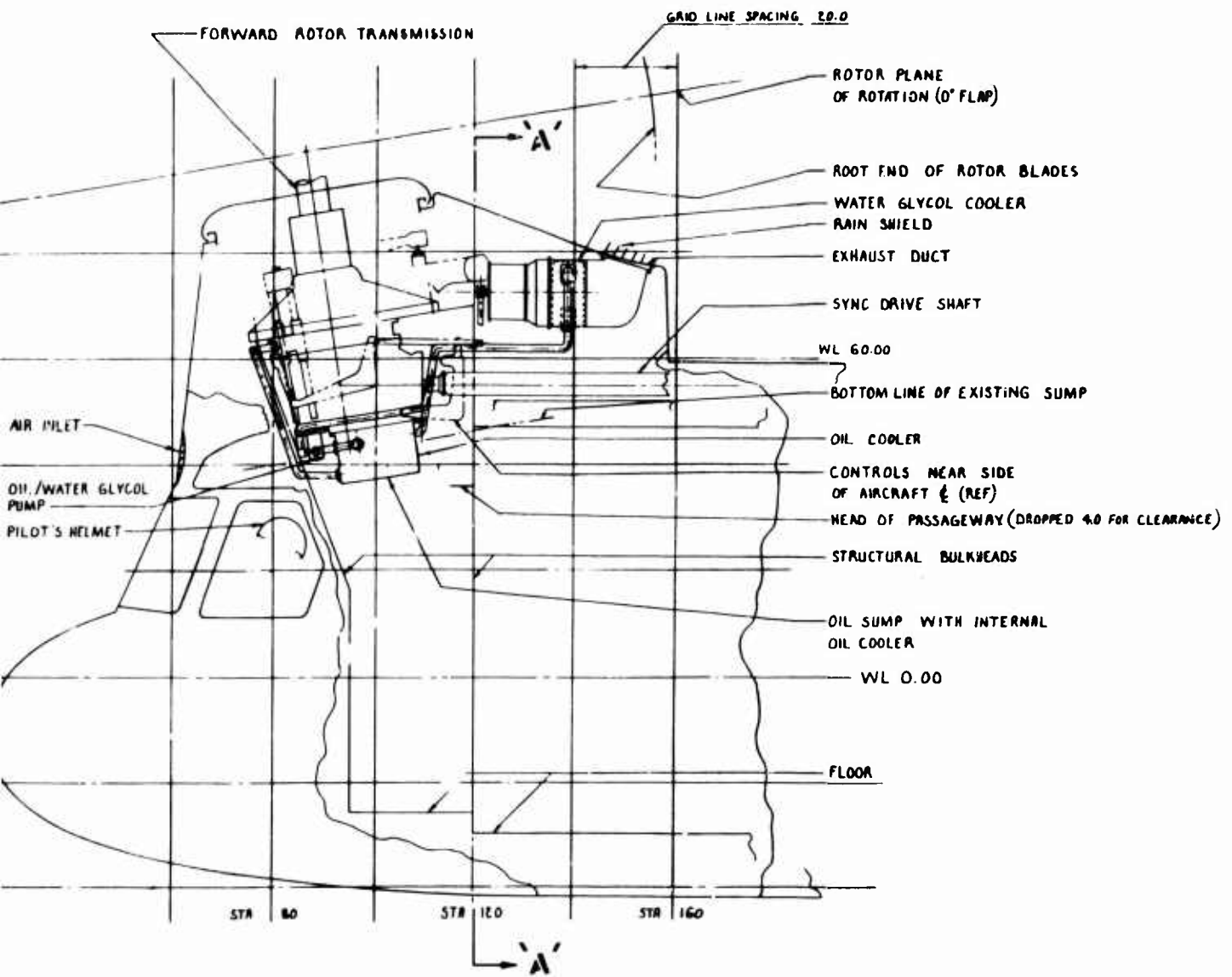

B

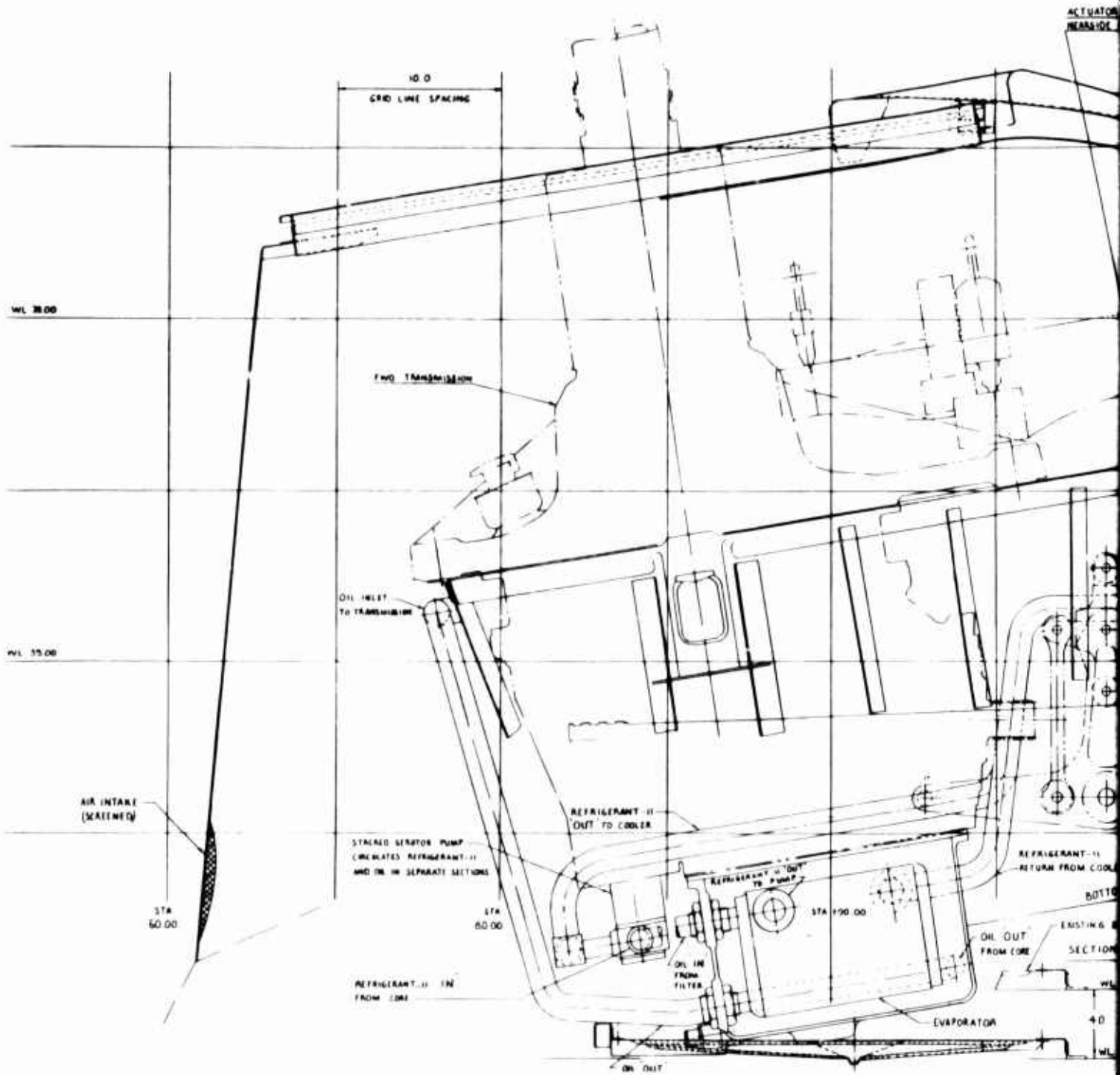
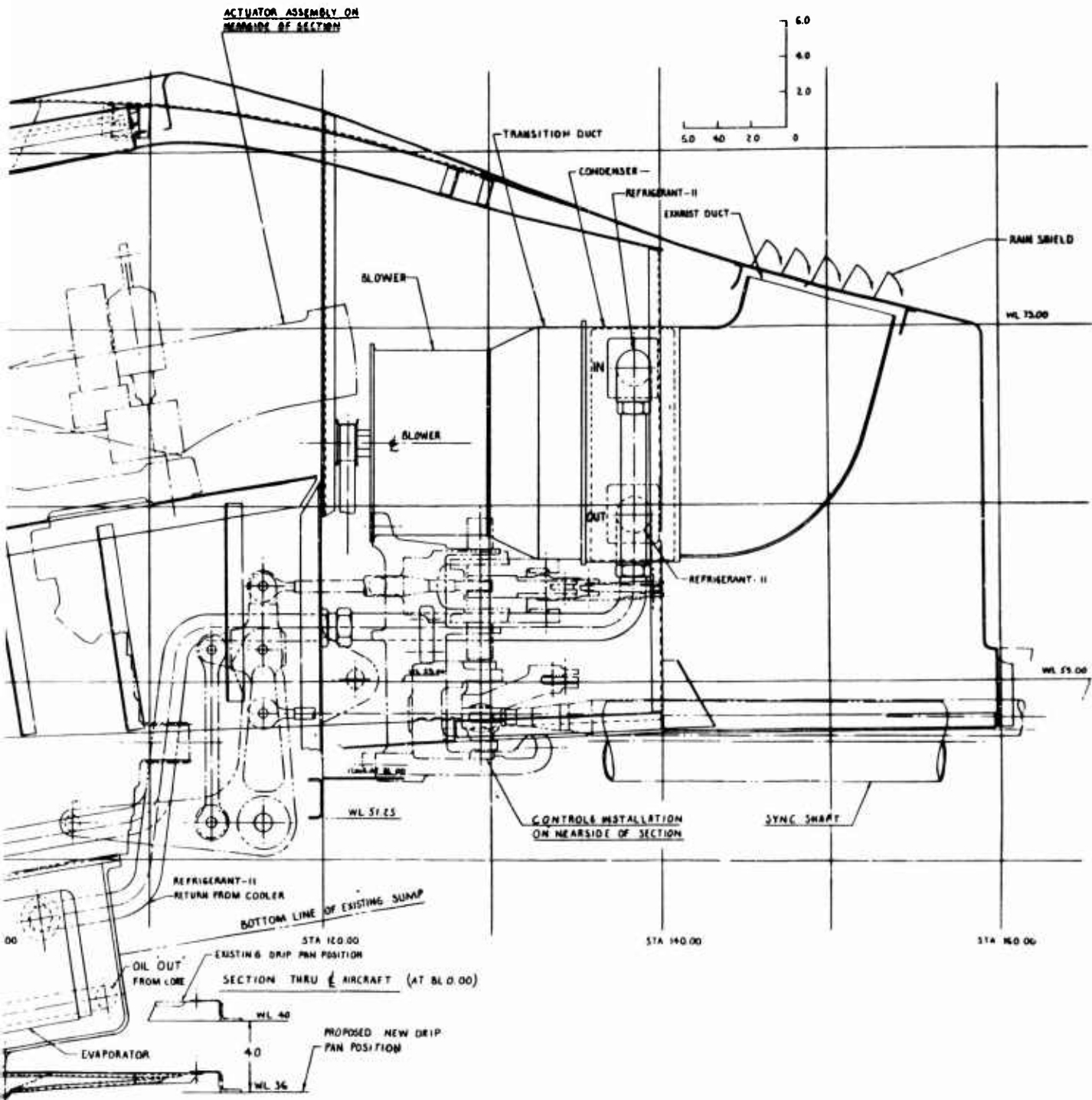
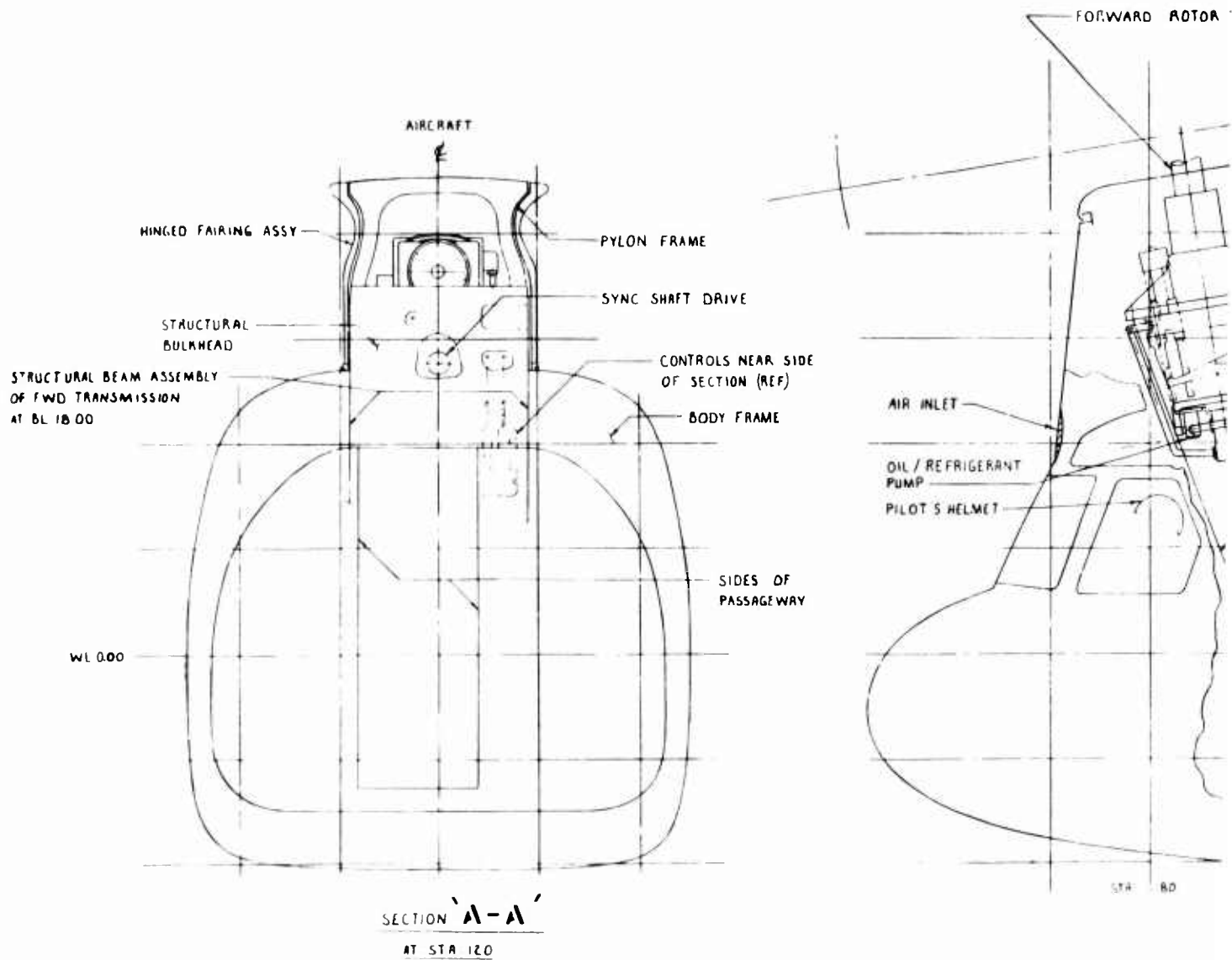

Figure 25. Oil-Boiling Refrigerant-Air System Layout.

A



B



A

Figure 26. Oil-Boiling Refrigerant-Air System.

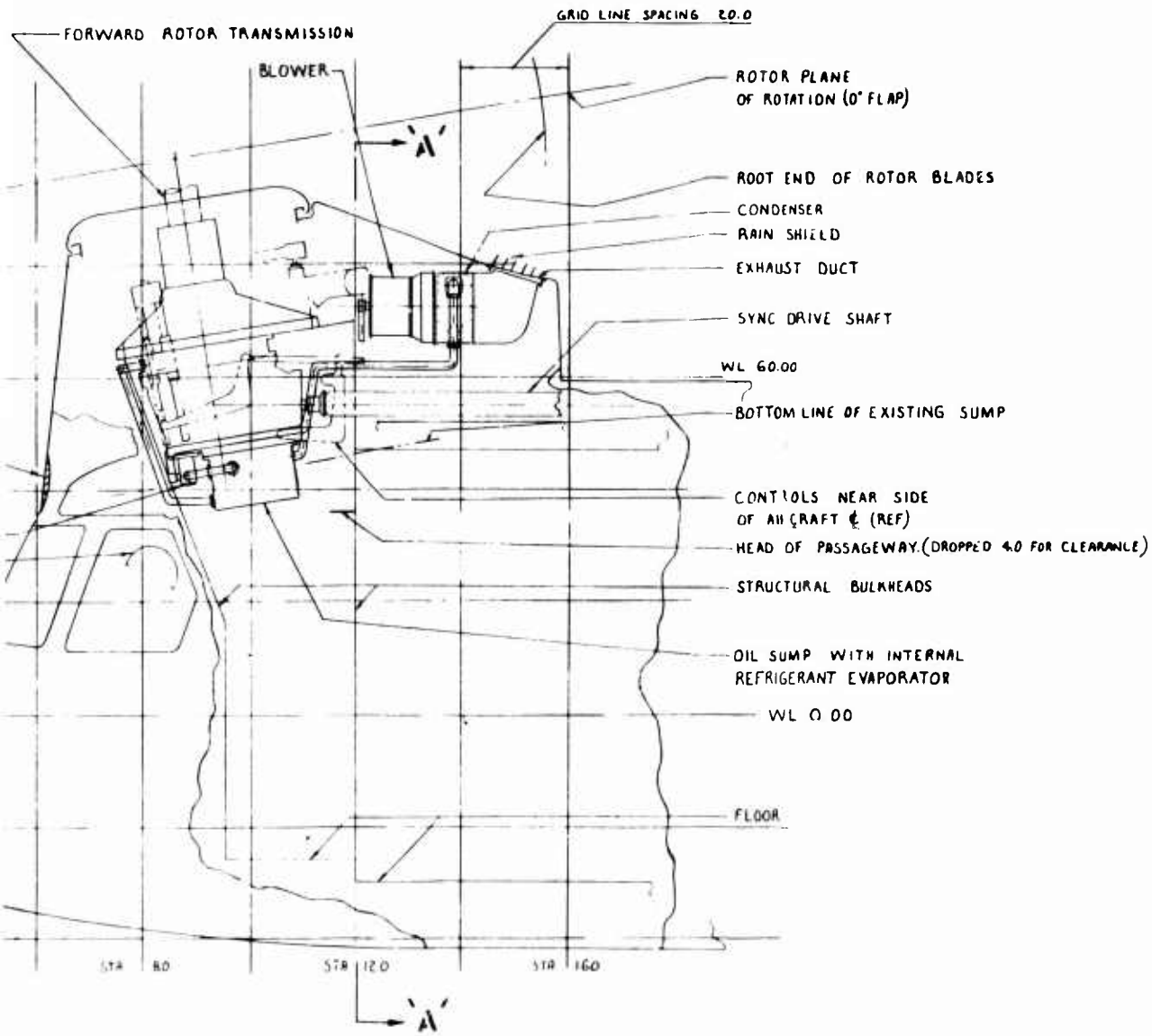

B

BLANK PAGE

RESULTS AND DISCUSSION

INTEGRAL OIL-AIR SYSTEM

The integral oil-air system is the most promising overall method of cooling a helicopter transmission. This system is very compact, relatively light in weight, and easier to maintain than the present system. The development of this system is within the present state of the art and affords a more standardized approach to transmission cooling. For the addition of 20 to 25 percent of the system weight by the incorporation of lightweight dualized armor plate, the system could be made virtually invulnerable to small-arms projectiles.

In order to incorporate the features of an integral oil-air cooling system into either a present or future helicopter, the manufacturing methods for this type of oil cooler must be fully developed. Airflow configuration optimization must also be accomplished to produce the most desirable design, so that the integral oil cooling concept becomes a standard design consideration.

CLOSE-COUPLED OIL-AIR SYSTEM

The close-coupled oil-air cooling system requires no development for helicopter application, only the incorporation of the basic concept into a particular design. Although this study has shown that the use of an oil cooler mounted directly on, or close to, the transmission is the most cost-effective approach to oil cooling, it affords no increase in the state of the art of transmission oil cooling. Because this system occupies more space than the integral oil-air system, thus being more vulnerable, it appears that, for the next-generation helicopter with large gross weights and high horsepower requirements, the close-coupled oil-air system will become less desirable than the integral oil-air system.

OIL-WATER/GLYCOL-AIR SYSTEM

The oil-water/glycol-air system is the third most desirable system studied. The development of this system appears to be less desirable than the integral cooling system for this particular transmission; however, for another application such as the circulation of a water/glycol cooling fluid through passages cast integrally in the transmission case, this system may be more desirable.

The advantage of this system is that the oil never leaves the transmission and thus reduces to a minimum the possibility of oil loss due to a combat hit. The disadvantages are that two heat exchangers are required (for any existing helicopter transmission), adding the need for a secondary fluid and increasing the overall system size and weight.

OIL-BOILING REFRIGERANT-AIR SYSTEM

This system is almost identical to the oil-water/glycol-air system and has virtually the same development problems. The only difference is that this system has not been as extensively developed and that the secondary fluid, Refrigerant-11, might impose logistics problems.

AIR CYCLE-HEAT PUMP SYSTEM

The air cycle-heat pump system study indicated that the optimum design would be an integral oil cooler and blower, because of the large horsepower requirements of the true air cycle-heat pump which produces an extreme weight penalty, making a pressure ratio of unity the optimum condition. Also, due to the speeds required of the expander/compressor turbine, a problem might develop with a turbine drive. The anticipated increased noise level would most likely be prohibitive also.

HEAT PIPE SYSTEM

This system employs a principle which, although promising, is not compatible with the high heat rejection rates produced by helicopter transmissions. The system has a definite desirability because of its natural redundancy; however, it occupies a great deal of space and presents many complicated design problems due to its physical construction.

VAPOR CYCLE SYSTEM

The vapor cycle system is a true refrigeration system which is not suited to helicopter usage because of the high equipment cost and low reliability in a helicopter environment. This system is ideal as a stationary unit for ground cooling. However, for helicopter usage where the heat loads and vibration levels are high, the equipment becomes costly because of the required weight reduction. The reliability of the system decreases drastically from that of a stationary unit because of the high vibration levels and induced system sealing problems.

AIR CYCLE-AIR COOLING SYSTEM

This system, which is virtually a combination of the air cycle-heat pump system and the close-coupled oil-air system, offers all the disadvantages of both methods and none of the advantages. As can be seen from Figure 12, the air cycle-air cooling system's vulnerability is 80 to 100 percent higher than the three most desirable systems and has almost three to four times the equivalent weight rating. Its reliability cost and hardware cost are also three to four times greater than the more desirable systems. Therefore, this system is considered to be undesirable for helicopter transmission oil cooling.

ABSORPTION SYSTEM

The absorption system is virtually useless in any form for airborne use, as shown by the system cost-effectiveness ratings in Table X. Compared to the present CH-47 total system rating of \$58,838, the absorption system is 3.2 times less cost effective but occupies approximately 4.7 times as much space.

CONCLUSIONS

The following conclusions are drawn from this study:

1. The integral oil-air system is the most cost effective of all the systems studied. It is also the least vulnerable to combat damage, except for the air cycle-heat pump system. This system should be studied further to establish a detailed design for a suitable bench test unit. An oil cooler should be manufactured for developmental bench testing and evaluation in a main rotor transmission on a production-type test stand.
2. The close-coupled oil-air system ranked second to the integral oil-air system in overall cost-effectiveness. However, this system represents the most expedient near-term solution if development time and cost are of the essence.
3. The two secondary-fluid systems, which include the oil-water/glycol-air and oil-boiling refrigerant-air systems, are competitive to the close-coupled oil-air system with regard to the vulnerability rating. These systems rank third and fourth in the total system rating, which is a 35-percent increase over the close-coupled oil-air system rating.
4. The air-cycle heat pump system was found to be the least vulnerable due to its complete containment within the transmission housing. However, it is rated fifth in cost-effectiveness due to a high equivalent weight penalty and low reliability rating, associated with high component cost.
5. The four systems with total cost-effectiveness ratings greater than the CH-47 production system were not found to be suitable for the high heat rejection rates encountered in current helicopter transmissions.

SELECTED BIBLIOGRAPHY

1. Kays and London, COMPACT HEAT EXCHANGERS, New York, N.Y., McGraw-Hill Publishing Company, 1964.
2. ASHRAE GUIDE AND DATA BOOK 1963 FUNDAMENTALS AND EQUIPMENT, published by the American Society of Heating, Refrigeration, and Air Conditioning Engineers, 1963.
3. Jordan and Priester, REFRIGERATION AND AIR CONDITIONING, New York, N.Y., Prentice-Hall Publishing Company, 1959.
4. Laner, Dr. B.E., HOW TO EVALUATE FILM COEFFICIENTS FOR HEAT TRANSFER CALCULATIONS, The Oil and Gas Journal, 1953.
5. Fraas, Arthur P., and Ozisik, M. Necati, HEAT EXCHANGER DESIGN, New York, N.Y., John Wiley and Sons, 1965.
6. Kreith, Frank, PRINCIPLES OF HEAT TRANSFER, Scranton, Pa., International Textbook Company, 1965.
7. Johnston, J.M., and Hughes, R.P., CH-46 AND CH-47 COMBAT DAMAGE ANALYSIS, The Boeing Company, Vertol Division, Philadelphia, Pa., Contract DAAD05-67-C-0169, No. 31205, February 1968.

APPENDIX
DETAILED HEAT TRANSFER CALCULATIONS FOR THE
INTEGRAL OIL-AIR SYSTEM

COOLER INLET CONDITIONS

- Required Heat Rejection - 2,200 Btu/min
 Oil Foam Flow Rate - 98.1 lb/min
 Oil Foam Inlet Temperature - 235°F
 Air Inlet Temperature - 125°F
 Oil Foam Specific Heat, C_p - 0.499 Btu/lb-°F
 Air Specific Heat, C_p - 0.241

NOTE: The calculations refer to the cooler shown in Figure 27.

OIL SIDE	AIR SIDE
$\Delta T = \frac{Q}{WC_p} = \frac{2,200}{98.1 \times 0.499}$ $= 44.9^\circ\text{F}$	Assume 59% effectiveness
$T_{\text{OUT}} = T_{\text{IN}} - \Delta T = 235 - 44.9$ $= 190.1^\circ\text{F}$	$Q = \epsilon WC_p (T_{\text{OIL IN}} - T_{\text{AIR IN}})$
Average Oil Temperature $= 190.1 + \frac{44.9}{2} = 212.6^\circ\text{F}$	$2,200 = 0.59 W 0.241 \times 110$
Oil Film Temperature $= \frac{190.1 + 212.6}{2} = 201.4^\circ\text{F}$	$W = \frac{2,200}{0.59 \times 0.241 \times 110}$ $= 140.6 \text{ lb/min}$
	$T = \frac{Q}{WC_p} = \frac{2,200}{140.6 \times 0.241} = 64.9^\circ\text{F}$
	$T_{\text{OUT}} = T_{\text{IN}} + \Delta T = 125 + 64.9$ $= 189.9^\circ\text{F}$

OIL SIDE	AIR SIDE
	Average Air Temperature
	$= 125 + \frac{64.9}{2} = 157.5^{\circ}\text{F}$
	Air Film Temperature
	$= \frac{157.5 + 189.9}{2} = 173.7^{\circ}\text{F}$
$WC = 98.1 \times 0.499$	$WC_p = 140.6 \times 0.241$
$= 49.0 \text{ Btu/min-}^{\circ}\text{F}$	$= 33.90 \text{ Btu/min-}^{\circ}\text{F}$
$\mu = 0.0886 \text{ lb/min-ft}$	$\mu = 0.00084 \text{ lb/min-ft}$
OIL SIDE FFA = 0.0171 ft ²	AIR SIDE FFA = 0.581 ft ²
$G = \frac{W}{\text{FFA}} = \frac{98.1}{0.0171}$	$G = \frac{W}{\text{FFA}} = \frac{140.6}{0.581}$
$= 5,737 \text{ lb/min-ft}^2$	$= 242 \text{ lb/min-ft}^2$
$D_h = 0.0080 \text{ ft}$	$D_h = 0.0112 \text{ ft}$
$R_e = \frac{D_h G}{\mu} = \frac{0.0080 \times 5,737}{0.0886}$	$R_e = \frac{D_h G}{\mu} = \frac{0.0112 \times 242}{0.00084}$
$R_e = 518$	$R_e = 3,226$
$\therefore j = 0.0188$	$\therefore j = 0.0075$
$P_r^{2/3} = 13.70$	$P_r^{2/3} = 0.77$
$h = \frac{j G C_p}{P_r^{2/3}}$	$h = \frac{j G C_p}{P_r^{2/3}}$
$h = \frac{0.0188 \times 5,737 \times 0.499}{13.70}$	$h = \frac{0.0075 \times 242 \times 0.241}{0.77}$

OIL SIDE	AIR SIDE
$h = 3.93 \text{ Btu/min-ft}^2\text{-}^\circ\text{F}$	$h = 0.57 \text{ Btu/min-ft}^2\text{-}^\circ\text{F}$
$A_D = 15.79 \text{ ft}^2$	$A_D = 15.16 \text{ ft}^2$
$A_I = 14.98 \text{ ft}^2$	$A_I = 106.7 \text{ ft}^2$
$E_f = 96.6\%$	$E_f = 89.5\%$
$A_E = A_D + E A_I$	$A_E = A_D + E A_I$
$A_E = 15.79 + 0.966 \times 14.98$	$A_E = 15.16 + 0.895 \times 106.7$
$\qquad\qquad\qquad = 30.26 \text{ ft}^2$	$\qquad\qquad\qquad = 110.66 \text{ ft}^2$
$hA_E = 3.93 \times 30.26$	$hA_E = 0.57 \times 110.66$
$hA_E = 118.9 \text{ Btu/min-}^\circ\text{F}$	$hA_E = 63.1 \text{ Btu/min-}^\circ\text{F}$

$$UA = \frac{1}{\frac{1}{hA_E(\text{OIL})} + \frac{1}{hA_E(\text{AIR})}} = \frac{1}{\frac{1}{118.9} + \frac{1}{63.1}}$$

$$UA = \frac{1}{0.0084 + 0.0158} = 41.3 \text{ Btu/min-}^\circ\text{F}$$

FOR THE AIR SIDE

$$NTU_{\text{MAX}} = \frac{UA}{WC_P} = \frac{41.3}{33.90} = 1.22$$

$$\frac{WC_P(\text{AIR})}{WC_P(\text{OIL})} = \frac{33.90}{49.0} = 0.69$$

$$\epsilon = 0.575 \text{ (from Figure 28)}$$

$$Q = WC_P (T_{\text{OIL IN}} - T_{\text{AIR IN}})$$

$$Q = 0.575 \times 33.90 \times 110 = 2,145 \text{ Btu/min}$$

Since most heat transfer calculations have an accuracy range of +5%, the 2,144 Btu/min falls within this range as applied to the required 2,200 Btu/min.

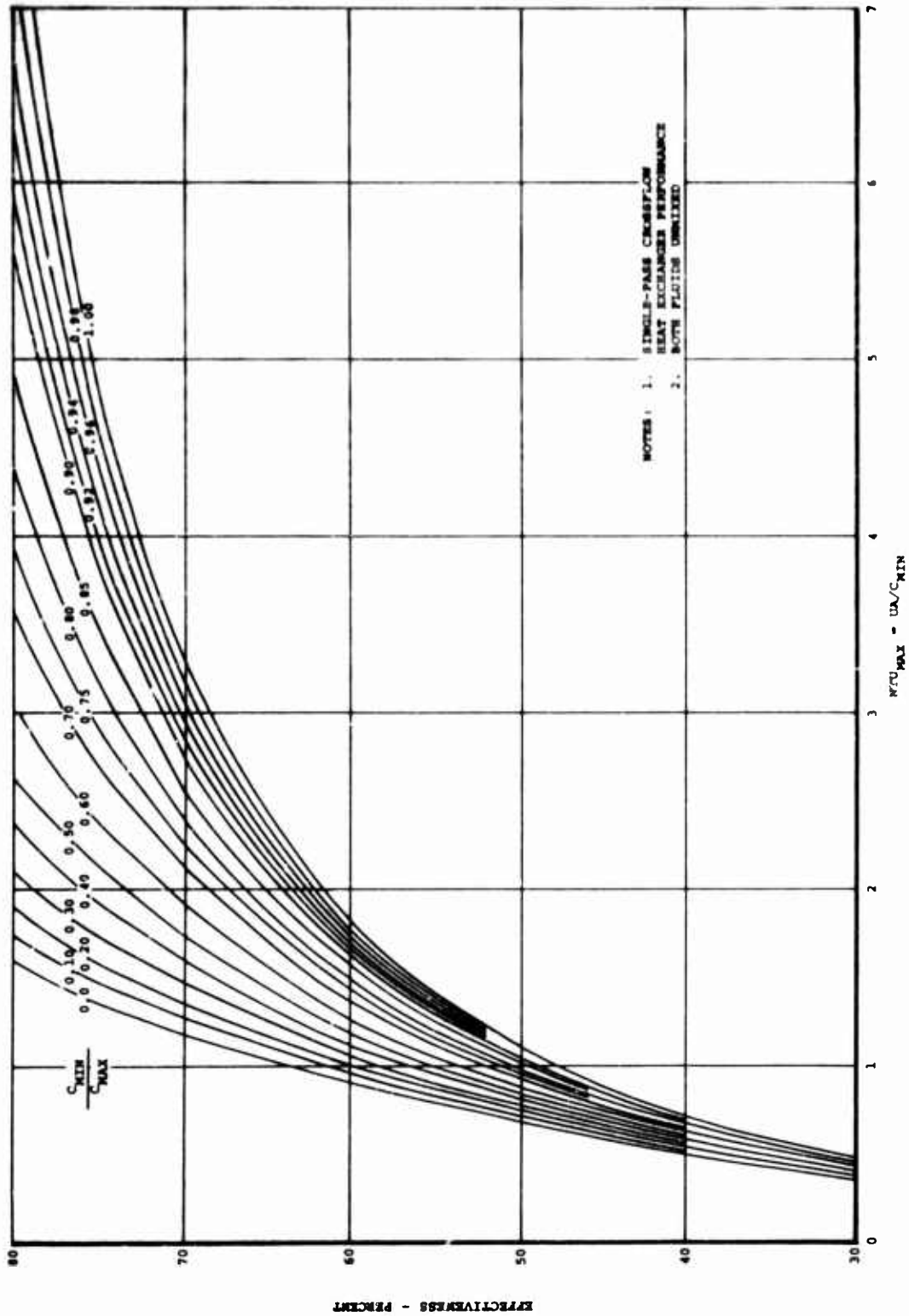

Figure 28. Heat Exchanger Effectiveness.

OIL SIDE	AIR SIDE
<p>Due to the lack of sufficient confidence in equations which will accurately calculate the pressure drop of an oil foam mixture through a complicated passage, heat exchanger manufacturers often approximate this pressure drop based on previous test data; thus, the oil foam pressure drop is estimated to be 25 to 30 psi maximum.</p>	<p>0.038</p> $\Delta P = f \frac{A_E}{FFA} \frac{G^2}{1.21 \times 10^6} \text{ in. H}_2\text{O}$ $\Delta P = 0.038 \times \frac{110.66}{0.581}$ $\times \frac{242^2}{1.21 \times 10 \times 0.0626}$ $\Delta P = 5.6 \text{ in. H}_2\text{O at } 0.0679 \text{ lb/ft}^3$

The oil cooler requires 140.6 lb/min of air at 125°F inlet to accomplish the required heat rejection of 2,200 Btu/min. The cooler pressure drop is estimated to be 5.6 inches of H₂O with associated ducting losses of 1.4 inches of H₂O at 0.0679 lb/ft³ density, while the oil cooler air exit temperature is approximately 190°F. From this information it is possible to determine the blower operational requirements as:

Mass Flow	140.6 lb/min
Air Inlet Temperature	190°F
Air Density at Inlet	0.0611 lb/ft ³
Required Static Pressure	6.3 in. of H ₂ O
Required Flow Rate	2,300 cfm
Maximum Allowable Blade Diameter	10 in.

A search of aircraft blower vendors has produced a blower which will meet all the performance requirements of the integral oil-air system design (see Figure 29).

From Figure 29, it can be seen that for the particular blower chosen, the optimum rpm appears to be approximately 5,700 rpm. For the stated operational requirements, the fan horsepower required is as follows:

$$P_S = 6.3 \text{ in.} \quad 10\text{-in. Diameter Opening} = 0.545 \text{ ft}^2$$

$$V = \frac{2,300 \text{ ft}^3/\text{min}}{0.545 \text{ ft}^2} = 4,220 \text{ ft/min}$$

$$P_V = \frac{\rho v^2}{2g} = \frac{0.0611}{2 \times 32.2} \left(\frac{4220}{60} \right)^2 \frac{1 \text{ in. H}_2\text{O}}{5.20 \text{ psf}} = 0.90 \text{ in. H}_2\text{O}$$

$$P_T = P_S + P_V = 6.3 + 0.90 = 7.20 \text{ in. H}_2\text{O}$$

$$P_T = 7.20 \text{ in. H}_2\text{O} \times 5.2 \text{ lb/ft}^2/\text{in. H}_2\text{O} = 37.4 \text{ lb/ft}^2$$

$$\text{Air Horsepower} = \frac{2,300 \text{ ft}^3/\text{min} \times 37.4 \text{ lb/ft}^2}{33,000 \text{ ft-lb/min/hp}}$$

$$\text{Air Horsepower} = 2.60 \text{ hp}$$

Assuming a blower blade efficiency of 70%, the blower horsepower is:

$$\frac{2.60 \text{ hp}}{0.70} = 3.72 = 3.7 \text{ hp.}$$

- NOTES: 1. 0.0611 POUNDS PER CUBIC FOOT DENSITY
2. 10-INCH BLADE DIAMETER

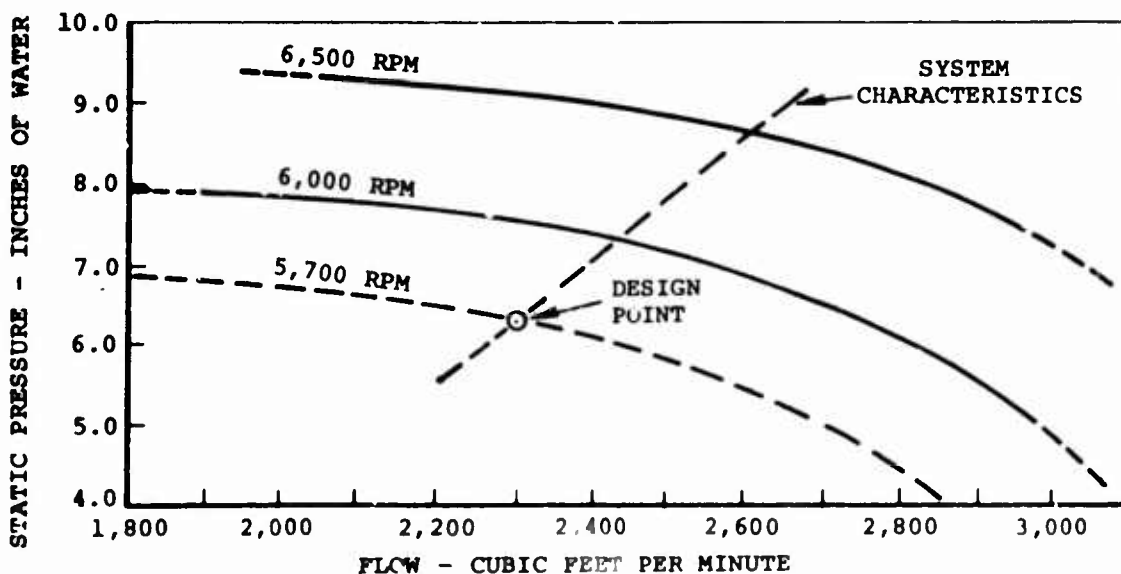

Figure 29. Blower Performance.

Unclassified

Security Classification

DOCUMENT CONTROL DATA - R & D

(Security classification of title, body of abstract and indexing annotation must be entered when the overall report is classified)

1. ORIGINATING ACTIVITY (Corporate author) The Boeing Company - Vertol Division Boeing Center, P. O. Box 16858 Philadelphia, Pennsylvania		2a. REPORT SECURITY CLASSIFICATION Unclassified	
3. REPORT TITLE RELATIVE VULNERABILITY AND COST-EFFECTIVENESS STUDY OF TRANSMISSION OIL HEAT REJECTION SYSTEMS		2b. GROUP	
4. DESCRIPTIVE NOTES (Type of report and inclusive dates) Final Technical Report, July 1967 - June 1968			
5. AUTHOR(S) (First name, middle initial, last name) A. J. Lemanski H. J. Rose			
6. REPORT DATE November 1968	7a. TOTAL NO. OF PAGES 99	7b. NO. OF REFS 7	
8a. CONTRACT OR GRANT NO. DAAJ02-67-C-0112	8b. ORIGINATOR'S REPORT NUMBER(S) USAAVLABS Technical Report 68-78		
8c. PROJECT NO. Task 1G121401D14414	8d. OTHER REPORT NUM(S) (Any other numbers that may be assigned this report) D8-0927		
9. DISTRIBUTION STATEMENT This document is subject to special export controls and each transmittal to foreign governments or foreign nationals may be made only with prior approval of US Army Aviation Materiel Laboratories, Fort Eustis, Virginia 23604.			
11. SUPPLEMENTARY NOTES		12. SPONSORING MILITARY ACTIVITY US Army Aviation Materiel Laboratories Fort Eustis, Virginia	
13. ABSTRACT This report describes the study of nine different methods, using the current state of the art, for dissipating the heat rejected into the oil in the forward transmission of a CH-47 helicopter. Five fluid heat transport systems and four dynamic heat pump and refrigeration systems were studied. In every case, the system under study was compared with the present production CH-47 oil-cooling system, which was used as a baseline for purposes of comparison. () The objective of this program was to determine which of the nine methods would be the most suitable for cooling the forward transmission and for reducing the vulnera- bility of the system by a substantial amount, while at the same time obtaining a cost- effective system compatible with helicopter requirements. All the methods studied were optimized for the CH-47 helicopter and were evaluated on the basis of vulnerability, weight (including horsepower penalty), reliability, maintainability, and cost. The evaluation provided a cost-effective value for each system studied. The results of this study indicate that the compact oil-to-air and oil-to-liquid-to-air systems are the most suitable for the CH-47 forward rotor transmission. With the addition of integral armor, the vulnerability would be reduced further, and the cost effectiveness would be increased substantially.			

DD FORM 1473

REPLACES DD FORM 1473, 1 JAN 64, WHICH IS OBSOLETE FOR ARMY USE.

Unclassified

Security Classification

Unclassified

Security Classification

16.	KEY WORDS	LINK A		LINK B		LINK C	
		ROLE	WT	ROLE	WT	ROLE	WT
	Helicopter Transmission Oil Cooling Systems Design Criteria Integral Oil-Air System Close-Coupled Oil-Air System Oil-Water/Glycol-Air System Oil-Boiling Refrigerant-Air System Air Cycle-Heat Pump System CH-47 Production Oil-Air System Heat Pipe System Vapor Cycle System Air Cycle-Air Cooling System Absorption System Vulnerability Weight Reliability Maintainability Cost Design Considerations Development Problems						

Unclassified

Security Classification