

UNCLASSIFIED

AD NUMBER

AD850941

LIMITATION CHANGES

TO:

Approved for public release; distribution is unlimited.

FROM:

Distribution authorized to U.S. Gov't. agencies and their contractors; Critical Technology; APR 1969. Other requests shall be referred to Air Force Weapons Laboratory, WLRP, Kirtland AFB, NM 87117. This document contains export-controlled technical data.

AUTHORITY

afwl ltr, 30 nov 1971

THIS PAGE IS UNCLASSIFIED

cy!

**HIGH PRESSURE HUGONIOT DATA OBTAINED
WITH A MANGANIN PIEZORESISTIVE
PRESSURE TRANSDUCER**



William H. Carden

ARO, Inc.

and

G. P. Crotwell, Jr., Captain, USAF

Air Force Weapons Laboratory

PROPERTY OF U. S. AIR FORCE
AEDC LIBRARY
F40600-69-C-0001

April 1969

This document is subject to special export controls and each transmittal to foreign governments or foreign nationals may be made only with prior approval of Air Force Weapons Laboratory (WLRP), Kirtland AF Base, New Mexico 87117.

This document has been approved for public release
its distribution is unlimited. *Per TM 72-17 dated 12pt, 72*

**VON KÁRMÁN GAS DYNAMICS FACILITY
ARNOLD ENGINEERING DEVELOPMENT CENTER
AIR FORCE SYSTEMS COMMAND
ARNOLD AIR FORCE STATION, TENNESSEE**

AEDC TECHNICAL LIBRARY



PROPERTY OF U. S. AIR FORCE
AEDC LIBRARY
F40600 - 69 - C - 0001

NOTICES

When U. S. Government drawings specifications, or other data are used for any purpose other than a definitely related Government procurement operation, the Government thereby incurs no responsibility nor any obligation whatsoever, and the fact that the Government may have formulated, furnished, or in any way supplied the said drawings, specifications, or other data, is not to be regarded by implication or otherwise, or in any manner licensing the holder or any other person or corporation, or conveying any rights or permission to manufacture, use, or sell any patented invention that may in any way be related thereto.

Qualified users may obtain copies of this report from the Defense Documentation Center.

References to named commercial products in this report are not to be considered in any sense as an endorsement of the product by the United States Air Force or the Government.

HIGH PRESSURE HUGONIOT DATA OBTAINED
WITH A MANGANIN PIEZORESISTIVE
PRESSURE TRANSDUCER

William H. Carden

ARO, Inc.

and

G. P. Crotwell, Jr., Captain, USAF

Air Force Weapons Laboratory

This document is subject to special export controls and each transmittal to foreign governments or foreign nationals may be made only with prior approval of Air Force Weapons Laboratory (WLRP), Kirtland AF Base, New Mexico 87117.

This document has been approved for public release
its distribution is unlimited. *Per TAB 72-17
dated 1 Sept, 72*

FOREWORD

The work reported herein was done at the request of the Air Force Weapons Laboratory (AFWL) of the Research and Technology Division of the Air Force Systems Command (AFSC), Kirtland Air Force Base, New Mexico (Capt. G. P. Crotwell, Jr., Project Engineer) under Program Element 65701H, Project 5710, Task DASA 15.025.

The results of tests presented were obtained by ARO, Inc. (a subsidiary of Sverdrup & Parcel and Associates, Inc.), contract operator of the Arnold Engineering Development Center (AEDC), Air Force Systems Command (AFSC), Arnold Air Force Station, Tennessee, under Contract F40600-69-C-0001. The tests were conducted intermittently between January 4, 1968, and October 8, 1968, under ARO Project No. VT0853, and the manuscript was submitted for publication on March 10, 1969.

Information in this report is embargoed under the Department of State International Traffic in Arms Regulations. This report may be released to foreign governments by departments or agencies of the U. S. Government subject to approval of the Air Force Weapons Laboratory (WLRP), or higher authority within the Department of the Air Force. Private individuals or firms require a Department of State export license.

This technical report has been reviewed and is approved.

Eugene C. Fletcher
Lt Colonel, USAF
AF Representative, VKF,
Directorate of Test

Roy R. Croy, Jr.
Colonel, USAF
Director of Test

ABSTRACT

The present investigation was initiated to develop the capability of making Hugoniot solid equation-of-state measurements using a piezoresistive pressure transducer and a two-stage light-gas gun. A manganin-epoxy transducer was successfully developed to measure pressures up to 350 kilobars when impacted by high velocity cylindrical projectiles of the material being tested. The calibration of the transducer was verified by two independent methods using materials for which the Hugoniot was known. Finally, the technique was used to determine Hugoniot data for tape-wound silica phenolic, carbon phenolic, and poco graphite in a pressure region where previous data did not exist. The technique wherein piezoresistive transducers are used in conjunction with two-stage light-gas guns is unique in its ability to provide high pressure Hugoniot data for this class of materials at modest cost.

This document is subject to special export controls and each transmittal to foreign governments or foreign nationals may be made only with prior approval of Air Force Weapons Laboratory (WLRP), Kirtland AF Base, New Mexico 87117.

CONTENTS

	<u>Page</u>
ABSTRACT	iii
NOMENCLATURE	vi
I. INTRODUCTION	1
II. EXPERIMENT DESIGN.	1
III. TEST CONFIGURATION	2
IV. TEST RESULTS	4
V. CONCLUSIONS	7
REFERENCES	8

APPENDIXES

I. ILLUSTRATIONS

Figure

1. Schematic of Experiment	13
2. Graphical Solution of Eqs. (1) and (2)	14
3. Projectile with Test Material Insert	15
4. Manganin-Epoxy Transducer	15
5. Range Configuration	16
6. Oscilloscope Traces of Transducer Output	17
7. Experimental Measurements of Aluminum and C-7 Epoxy Projectiles	18
8. Pressure versus Particle Velocity for C-7 Epoxy	19
9. Experimental Measurements for Materials of Interest	20
10. Particle Velocity Data for Materials of Interest.	21
11. Compressibility Data for Materials of Interest	22

II. TABLES

I. Experimental Results	23
II. Computed Material Properties	24

NOMENCLATURE

K	Piezoresistive constant
P	Impact pressure
P_g	Pressure in gage
P_o	Pressure before impact
P_s	Pressure in test sample
R_o	Resistance of gage element before impact
ΔR	Resistance change at impact
U_o	Impact velocity
U_p	Particle velocity
U_{pg}	Particle velocity in gage
U_{ps}	Particle velocity in test sample
U_s	Shock velocity
U_{sg}	Shock velocity in gage
U_{ss}	Shock velocity in test sample
V_o	Voltage before impact
ΔV	Voltage change at impact
η	Compressibility = ρ/ρ_o
ρ	Mass density of test sample after impact
ρ_o	Mass density of test sample before impact

SECTION I INTRODUCTION

Reentry vehicle materials may experience extreme shock pressures when subjected to a defensive counterattack. The response of this class of materials to intense dynamic loading must be known in order to conduct realistic survivability/vulnerability assessments of reentry vehicle systems. Up to the present time, the necessary high pressure Hugoniot equation-of-state data for this class of materials have been nonexistent.

Hugoniot measurements obtained using standard experimental techniques are limited to shock pressures usually below 100 kilobars (kbar) for the class of materials of interest because of the relatively low velocities produced by shaped high explosive charges or single-stage gas guns. The velocities required to produce shock pressures up to 350 kbar in these materials are attainable with two-stage light-gas guns. The present investigation was initiated to develop the capability of making Hugoniot measurements using a piezoresistive pressure transducer and a two-stage light-gas gun. Following the successful development of the test capability, Hugoniot measurements were made for several materials of interest. The experimental work was conducted in the Hypervelocity Impact Ranges of the von Kármán Gas Dynamics Facility (VKF), Arnold Engineering Development Center (AEDC).

SECTION II EXPERIMENT DESIGN

The technique used in this basic Hugoniot experiment was to impact a sample of the test material onto a target containing a pressure transducer capable of measuring pressures in the 100- to 350-kbar range. A schematic of the projectile and target conditions during impact is shown in Fig. 1 (Appendix I). The velocity of the test sample before impact is U_0 . At the time of impact, a shock wave is driven into the test sample at a velocity, U_{SS} , and another shock wave is driven into the target at a velocity, U_{Sg} . The particle velocities in the two materials at the interface at the time of impact are U_{ps} for the test sample and U_{pg} for the target. These shock and particle velocities are all measured relative to points in the undisturbed (unshocked) portions of the sample material and target material, respectively. The following conditions exist at the

interface during impact: (1) particle velocity across the interface is constant; and (2) stress across the interface is constant (Refs. 1 and 2). That is,

$$U_o = U_{pg} + U_{ps} \quad (1)$$

$$P_s = P_g \equiv P \quad (2)$$

The Hugoniot properties of a material can be expressed in terms of the relation between shock pressure and particle velocity. For impact of like materials, Eq. (1) shows that the particle velocity (U_{pg} or U_{ps}) is equal to one-half of U_o . Therefore, if impact velocity and shock pressure at impact are known (measured), the relation between pressure and particle velocity for the material can be determined. Furthermore, if impact velocity and shock pressure at impact are measured for dissimilar materials, the relation between pressure and particle velocity for one material can be determined, provided this relation is known for the other material. The use of Eqs. (1) and (2) to obtain these material properties is shown graphically in Fig. 2.

Two measurements were required on each test: impact velocity (U_o), and shock pressure (P). Details of these measurements will be presented in the next section of this report.

SECTION III TEST CONFIGURATION

Impact Ranges S-1 and S-2 are described in detail in Ref. 3. The launchers used on these ranges have a nominal bore size of 0.5 in. The projectiles are fired into evacuated range tanks. The projectile design consisted of a Lexan® sleeve which encased a cylindrical slug of the test material, as shown in Fig. 3. The taper on the rear of the projectile prevented premature motion in the gun barrel during launch. The test material slug was held in place by means of a press fit. The materials which were tested included aluminum, C-7 epoxy, tape-wound silica phenolic (TWSP), carbon phenolic (CP), and poco graphite.

The targets used on these tests were, in reality, transducers designed to measure the shock pressure generated during impact. The piezoresistive element of the transducer consisted of a length of Manganin® wire, embedded just beneath and parallel to the front surface of the insulator material, Armstrong C-7 epoxy. This transducer concept has been described in previous papers and reports (Refs. 4

through 9). Briefly, the transducer is designed so that the shock pressure induced in the insulator material by impact is monitored by the change in resistance of the Manganin wire embedded in the epoxy. Manganin (nominally 84-percent copper (Cu), 12-percent manganese (Mn), and 4-percent nickel (Ni)) is an alloy whose change in electrical resistance because of dynamic compression is much larger than the corresponding change because of temperature. Furthermore, the resistance of manganin varies linearly with pressure over a wide range of pressures, and suitable resistances and resistance changes can be obtained using Manganin wire of convenient dimensions. Type C-7 epoxy is a castable solid insulator which retains a high resistivity at the required shock pressures and temperatures.

Pressure transducers composed of Manganin in C-7 epoxy have been in use for several years in conjunction with explosively driven plates and single-stage gas guns. These launching devices usually are not capable of producing impact velocities above about 10,000 ft/sec. To the knowledge of the authors, the present investigation represents the first attempt to use the Manganin-epoxy transducer at higher velocities, specifically those obtainable with two-stage light-gas launchers. The transducer performance requirements imposed by the relatively small, high velocity projectile were more severe than those usually associated with low speed tests.

A section-view of the transducer is presented in Fig. 4. Manganin wire having a diameter of 0.003 in. is cast into the epoxy in a four-lead configuration. The outer leads carry current to the active portion of the gage, which is recessed a small distance (typically 0.040 to 0.120 in.) beneath the front surface of the epoxy. The voltage drop across the active portion of the gage is measured by means of the inner leads.

Considerable effort was expended in the development of the transducer to provide reliable operation with a reading time as long as possible. It was necessary to keep the length of the active portion of the gage much smaller than the projectile diameter to eliminate two-dimensional edge effects. It was also necessary to orient the voltage and current leads at an angle of 60 degrees to the front surface of the gage to prevent the shearing of these wires before data could be recorded. Reading times from 0.8 to 1.2 μ sec were consistently obtained. Slightly better gage performance was obtained when the active element recession depth was in the 0.040 to 0.070 in. range.

The current to the gage was supplied by a triggered constant current power supply. The power supply has a constant voltage source that produces constant current (about 3.3 amp) through the use of a ballast

resistance. Details of this device can be found in Ref. 9. The resistance of the active gage element was typically 0.15 to 0.30 ohms.

The target was located near the launcher muzzle, as indicated in Fig. 5. The projectile passed through two helium-neon laser beams (1-mm diam) prior to impact. Projectile velocity was obtained from the measured time interval between interruption of the beams which were spaced a known distance apart. The power supply trigger was initiated by interruption of the laser beam closest to the target. A narrow bandpass, optical filter was used in front of the photomultiplier tube in each radiometer to eliminate all wave lengths of light except those corresponding to the laser. The response time for the detector system, which included one stage of amplification, was typically less than 1 μ sec.

The voltage drop across the active element of the gage was displayed on two Tektronix type 555 oscilloscopes, and these displays were recorded on Polaroid[®] film. Typical oscilloscope traces are shown in Fig. 6. The first oscilloscope, with which a Tektronix type L preamplifier was used, was set up to record the complete time history of the gage voltage drop beginning with the time the second laser beam was interrupted. The turn-on of the power supply, instant of impact, and instant of gage destruction are prominent features of this oscilloscope record (Fig. 6a). The complete voltage excursion was displayed on the oscilloscope. The second oscilloscope, with which a Tektronix type 1A5 preamplifier was used, was set up to record the impact event in greater detail. Triggering of the beam was delayed an appropriate length of time so that the impact event could be viewed at a fast sweep rate. An appropriate offset voltage was preset into the preamplifier to permit an increased vertical sensitivity which, together with the fast sweep rate, provided a more detailed record of the response of the transducer to the shock pressure (Fig. 6b). The horizontal base line in the figure represents the offset voltage, which was measured with a digital voltmeter before each test.

SECTION IV TEST RESULTS

The oscilloscope traces (see Fig. 6) were used to obtain the quantity $\Delta V/V_0$, where V_0 is the voltage drop across the active element of the gage prior to impact and ΔV is the step change in voltage which occurs at impact. Since the ratio $\Delta V/V_0$ can be scaled directly from the overall trace (Fig. 6a) without reliance on the oscilloscope voltage

calibration, use of this trace was preferred, particularly at the higher values of pressure. The greater resolution afforded by the offset trace (Fig. 6b) was compromised somewhat by the dependence upon the offset voltage measurement and the oscilloscope voltage calibration. Nonetheless, the results obtained from the two traces usually agreed within 10 percent.

Because of the nonlinear output of the recording circuits as a function of the active element resistance change, the measured change in voltage was corrected according to the analysis of Ref. 9 to obtain the correct change in resistance, viz,

$$\Delta R/R_0 = f(\Delta V/V_0) \quad (3)$$

The pressure was then computed from the expression

$$P = 1/K (\Delta R/R_0) \quad (4)$$

where K, the piezoresistive coefficient of Manganin, was taken as 0.0029 kbar^{-1} (Ref. 9).

It was pointed out in the Introduction that, if the Hugoniot for one material involved in an impact is known, then the locus of points on the Hugoniot for the other material can be determined if the pressure and impact velocity are known. In the present application, the Hugoniot for the C-7 epoxy in the transducer must be known before the Hugoniot of a material impacted into the transducer can be determined. Hugoniot data for C-7 epoxy are available (Ref. 9), but it was deemed advisable to provide an independent set of Hugoniot measurements for C-7 epoxy using the Manganin-epoxy gage itself. Two methods were used to provide these independent C-7 epoxy Hugoniot measurements. The first, and most straightforward method was to conduct impact tests with C-7 epoxy itself as the projectile material. In this case the C-7 particle velocity was simply equal to one-half of the impact velocity. The second method was to conduct impact tests with type 2024 aluminum as the projectile material. Since the Hugoniot for aluminum is well defined, the particle velocity for the C-7 epoxy in the target can be calculated.

The experimental measurements (pressure and impact velocity) for the Al→C-7 and C-7→C-7 impacts are presented in Fig. 7. In cases where two data points are shown for the same impact velocity, the impact pressure was computed from both the overall oscilloscope trace and the offset trace. The solid lines through each set of data represent a second-degree least squares fit of those data. The broken lines represent error bands around the least squares curves defined by error limits of $\pm 500 \text{ ft/sec}$ in impact velocity and ± 5 percent in pressure. It can be seen that most of the experimental points lie within these error bands.

To eliminate this source of data scatter while retaining the essential features of the experimental data, the least square curves will be used instead of individual data points for further calculations.

The Al→C-7 and C-7→C-7 curve fits from Fig. 7 are presented in the pressure-particle velocity plane in Fig. 8. The C-7→C-7 results were obtained by taking one-half of the impact velocity. The Al→C-7 results were calculated using Eq. (1) with the aluminum Hugoniot curve shown in Fig. 8 (Ref. 10). There is a slight disagreement between the two curves representing the C-7 Hugoniot obtained by the two experimental methods. However, if the error bands for the Al→C-7 data in Fig. 7 are retained for the particle velocity calculation as shown in Fig. 8, then the particle velocity curve representing the C-7→C-7 impacts lies within their limits.

The previously available C-7 epoxy Hugoniot data points (Ref. 9) are plotted individually in Fig. 8. These points tend to lie between the two curves representing the Al→C-7 and C-7→C-7 impacts, with their general trend in better agreement with the C-7→C-7 curve. This agreement, although not perfect, is held to constitute a valid calibration of the Manganin-epoxy transducer, since the previously available Hugoniot points for C-7 epoxy have been substantially verified. For the purpose of computing the Hugoniot properties of the other materials which were tested, a pressure-particle velocity relationship obtained from a least squares fit of the previously available C-7 epoxy data (Ref. 9) will be utilized, viz,

$$U_p = 0.05345 + 1.1938 P - 0.72535 P^2 \quad (80 \text{ kbar} < P < 300 \text{ kbar}) \quad (5)$$

where P is in megabars and U_p is in $\text{cm}/\mu\text{sec}$ ($=(\text{km}/\text{sec})/10$).

The experimental measurements for poco graphite, carbon phenolic, and silica phenolic are presented in Fig. 9. Also shown are the second-degree least squares fits of these data and the error bands representing limits of ± 500 ft/sec in velocity and ± 5 percent in pressure. The curve fits for poco graphite and silica phenolic are reasonably well defined by the available data. Unfortunately, the curve for carbon phenolic is based upon only one test at a pressure greater than 200 kbar. Figure 10 presents the computed pressure-particle velocity curves corresponding to the least squares curves in Fig. 9.

The shock pressure and the shocked material mass density are related to the shock velocity, the particle velocity, and the initial pressure and density through the following equations (Refs. 1 and 2):

$$P - P_o = \rho_o U_s U_p \approx P \quad (6)$$

$$\eta \equiv \rho/\rho_o = \frac{U_s}{U_s - U_p} \quad (7)$$

In Eq. (6) the initial pressure is negligible compared with the pressure after impact. Using these relations, the shock velocity and density ratio have been calculated for the least squares curves representing the experimental data. The results for density ratio are presented in Fig. 11. The trends exhibited by these curves are reasonable. Unfortunately, however, other data in this pressure region are not available for comparison with the present results. The shape of the curve for carbon phenolic may have been affected by the absence of sufficient experimental points in the high pressure region.

The experimental measurements obtained during this investigation are tabulated in Table I (Appendix II). The calculated Hugoniot data for the materials under investigation, corresponding to the least squares curve fit of the experimental data, are presented in Table II.

SECTION V CONCLUSIONS

The basic objective of obtaining high pressure Hugoniot data on the materials of interest has been accomplished. The Manganin-epoxy transducer device was adapted to the requirements imposed by the small, high velocity projectile. Data were obtained in a pressure region where previous data did not exist for the materials of interest.

Several observations can be made regarding the test technique. The present technique required the measurement of pressure and impact velocity, whereas the usual technique for Hugoniot measurements is to measure shock velocity and particle velocity. The latter technique is straightforward since the pressure (P) and compressibility (η) can be calculated immediately using Eqs. (6) and (7). With the present technique the shock velocity and particle velocity must first be calculated using the measured pressure and impact velocity, together with the known Hugoniot of one material. Therefore, small errors in the present measurements tend to produce larger errors in the compressibility (η) calculation, since the difference between shock velocity and particle velocity appears in the denominator of Eq. (7). The least squares curve fits were used to minimize this effect.

The inaccuracies in the test technique are reflected in the pressure-particle velocity results for C-7 epoxy (Fig. 8), in which there was a slight disagreement between the result for Al→C-7 and that for C-7→C-7. This was on the order of 10 percent at the higher pressures. Also, it should be pointed out that the uncertainty in the previously available Hugoniot data for C-7 epoxy is about ± 6 percent in the region above 170 kbar. This being the case, the disagreement in the present results for C-7 epoxy is not considered to be excessive. However, additional work on transducer calibration would be highly desirable.

The present gage design does not represent an optimum configuration. If the C-7 epoxy could be replaced by an insulator material with higher shock impedance so that the particle velocity of the gage material becomes small compared with that for the test sample, then an error in impact velocity measurement would result in a smaller percentage error in test sample particle velocity. Other improvements to increase reading time and signal level are possible. One highly desirable design modification would involve the addition of a second active element beneath the present element, thereby providing a means for directly measuring the shock velocity in the transducer.

The test technique which has been developed provides an inexpensive method for obtaining Hugoniot data at the higher velocities required for certain materials of interest. Since the Manganin-epoxy transducer is a device capable of providing a direct analog of the pressure-time history during a high velocity impact, this test technique is also attractive for related investigations (i. e., shock wave attenuation studies) for which the pressure-time history would be required.

REFERENCES

1. Duvall, G. E. and Fowles, G. R. "Shock Waves." High Pressure Physics and Chemistry, Vol. II. (R. S. Bradley, Editor), Academic Press, New York, 1963, pp. 209-291.
2. Crotwell, G. P. "Determination of a Single Point on the Hugoniot Solid Equation of State Curve." Air Force Institute of Technology Thesis 63-6, August 1963.
3. Payne, J. J. "Summary of Impact Testing for NASA Project SUPER." AEDC-TR-66-97 (AD488517), September 1966.
4. Fuller, P. J. A. and Price, J. H. "Dynamic Pressure Measurements to 300 Kilobars with a Resistance Transducer." British Journal of Applied Physics, Vol. 15, 1964, pp. 751-758.

5. Bernstein, David and Keough, D. D. "Piezoresistivity of Manganin." Journal of Applied Physics, Vol. 35, No. 5, May 1964, pp. 1471-1474.
6. Keough, D. D. and Wilkinson, W. "Manganin-Wire Shock-Transducer Investigation." AFWL-TR-65-170 (AD476970), December 1965.
7. Keough, D. D. and Williams, R. F. "Piezoresistive Transducer for Shock Wave Studies." AFWL-TR-67-81 (AD824942), December 1967.
8. Williams, E. O. "An Etched Manganin Gage System for Shock Pressure Measurement in a High Noise Environment." Journal of Environmental Sciences, Vol. 11, No. 3, June 1968, pp. 11-17.
9. Keough, D. D. "Procedure for Fabrication and Operation of Manganin Shock Pressure Gages." AFWL-TR-68-57, August 1968.
10. McQueen, R. G., Marsh, S. P., Fritz, J. M. Carter, W. C., and Taylor, J. W. "Equation of State of Solids from Shock Wave Studies." High Velocity Impact Phenomena. (Ray Kinslow, Editor), Academic Press, New York, to be published.

APPENDIXES
I. ILLUSTRATIONS
II. TABLES

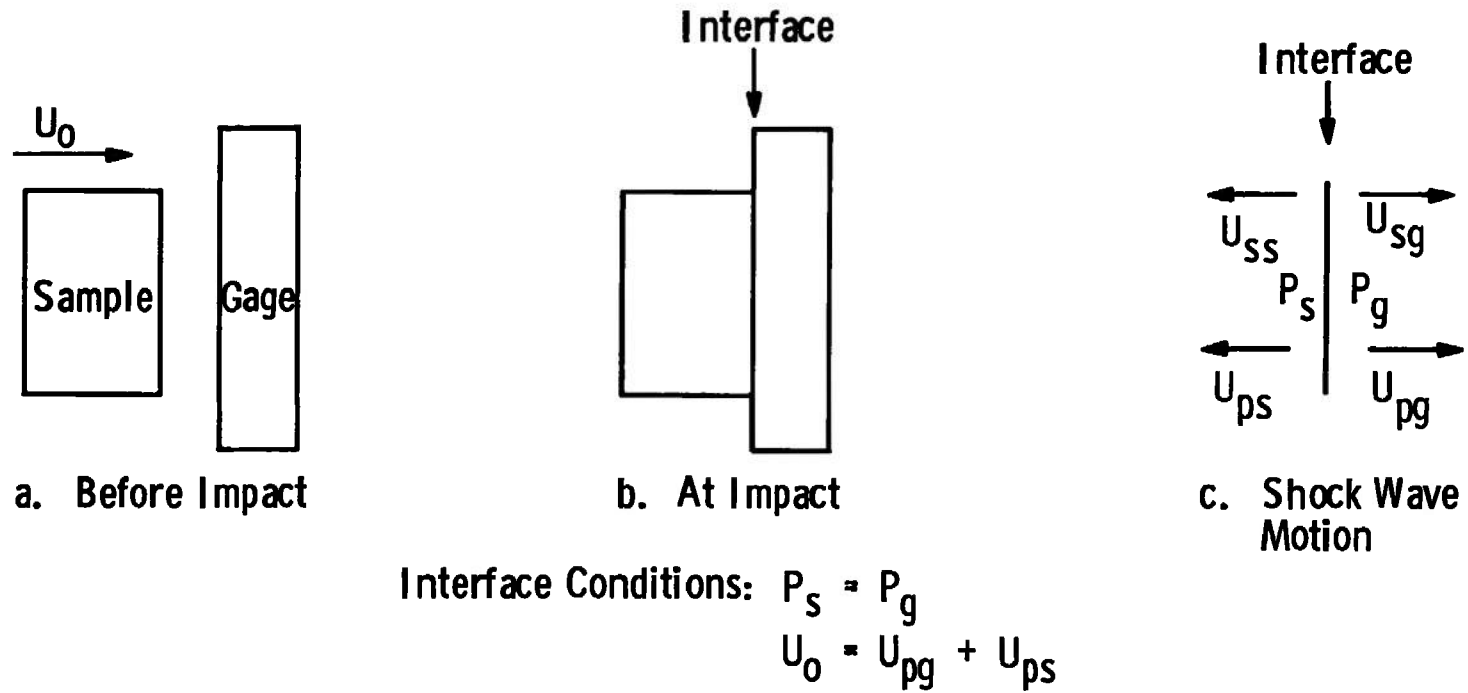

Fig. 1 Schematic of Experiment

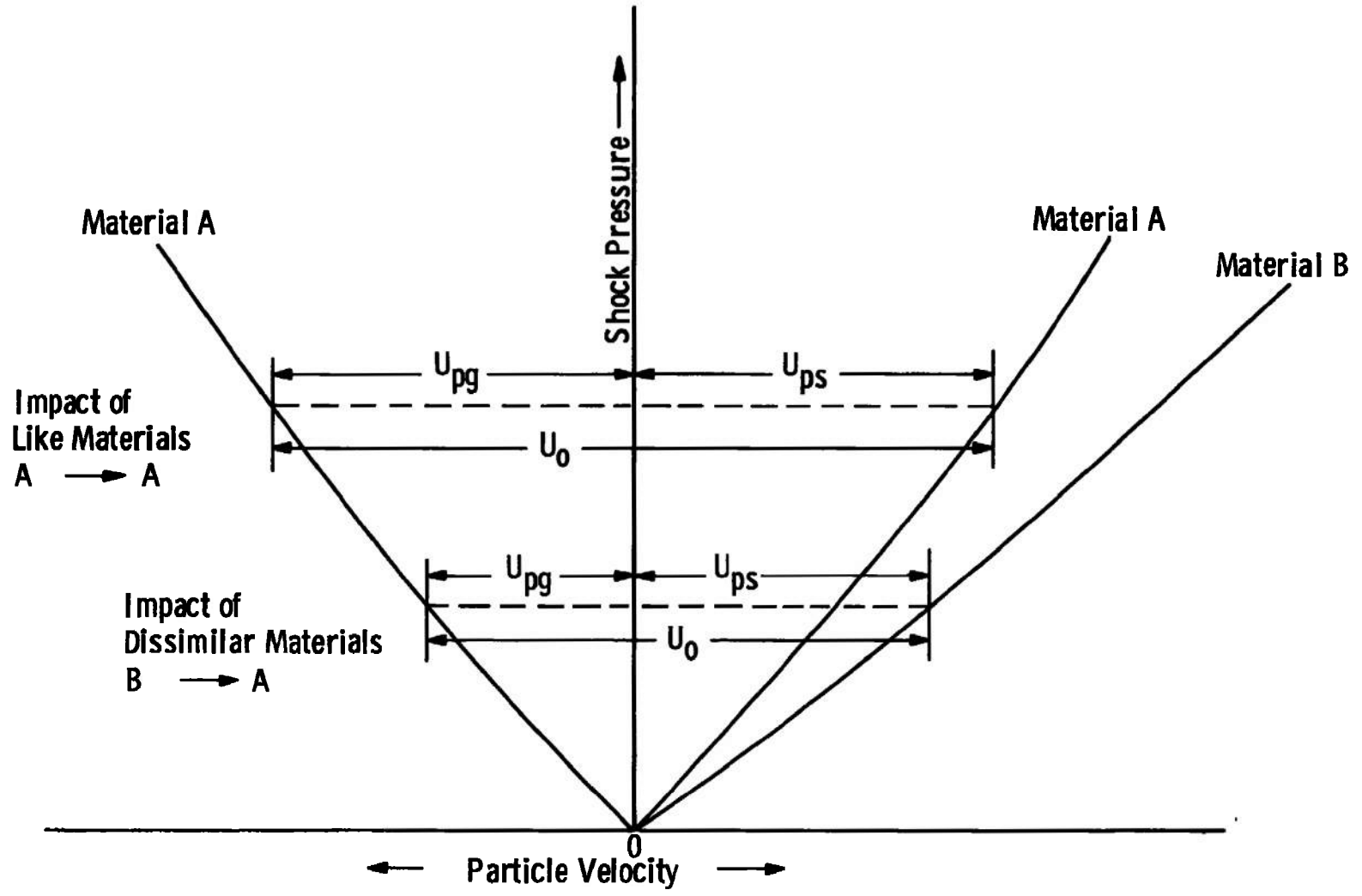

Fig. 2 Graphical Solution of Eqs. (1) and (2)

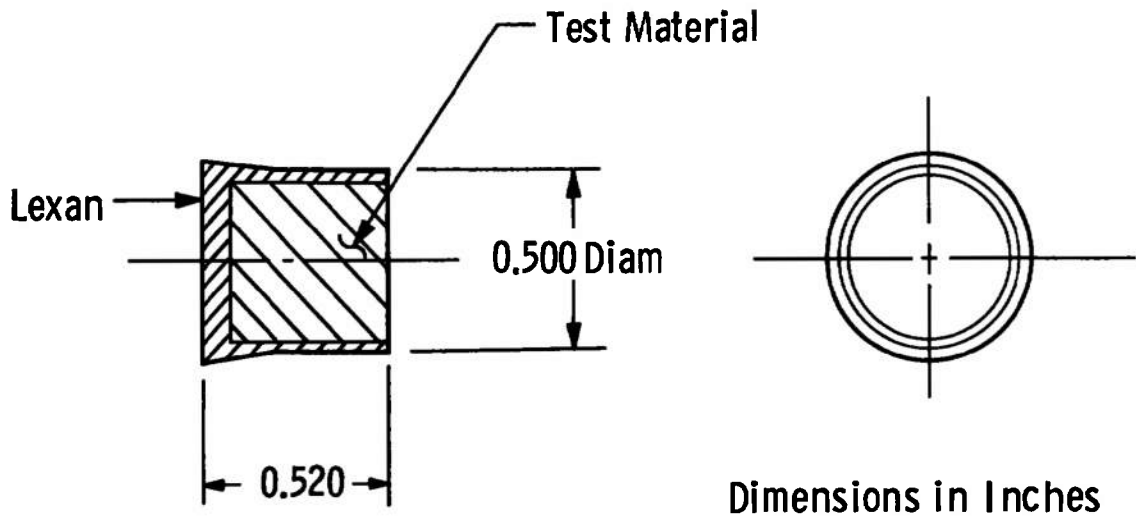

Fig. 3 Projectile with Test Material Insert

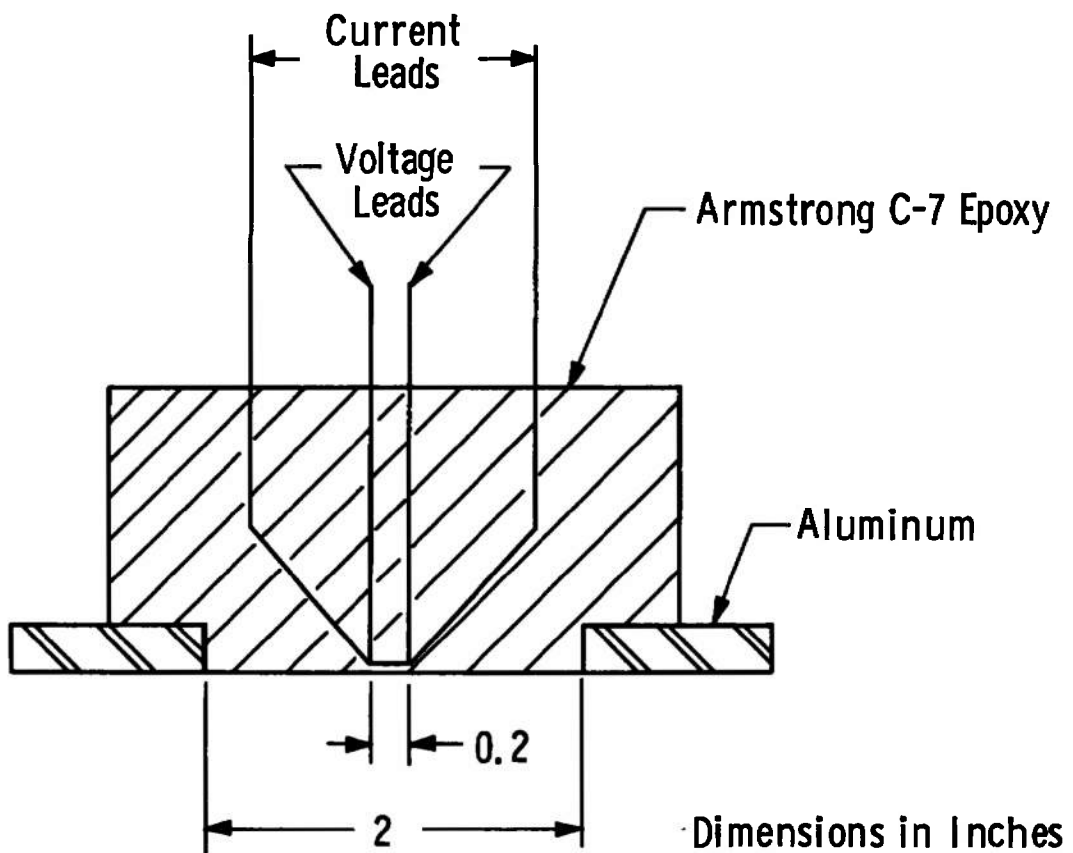

Fig. 4 Manganin-Epoxy Transducer

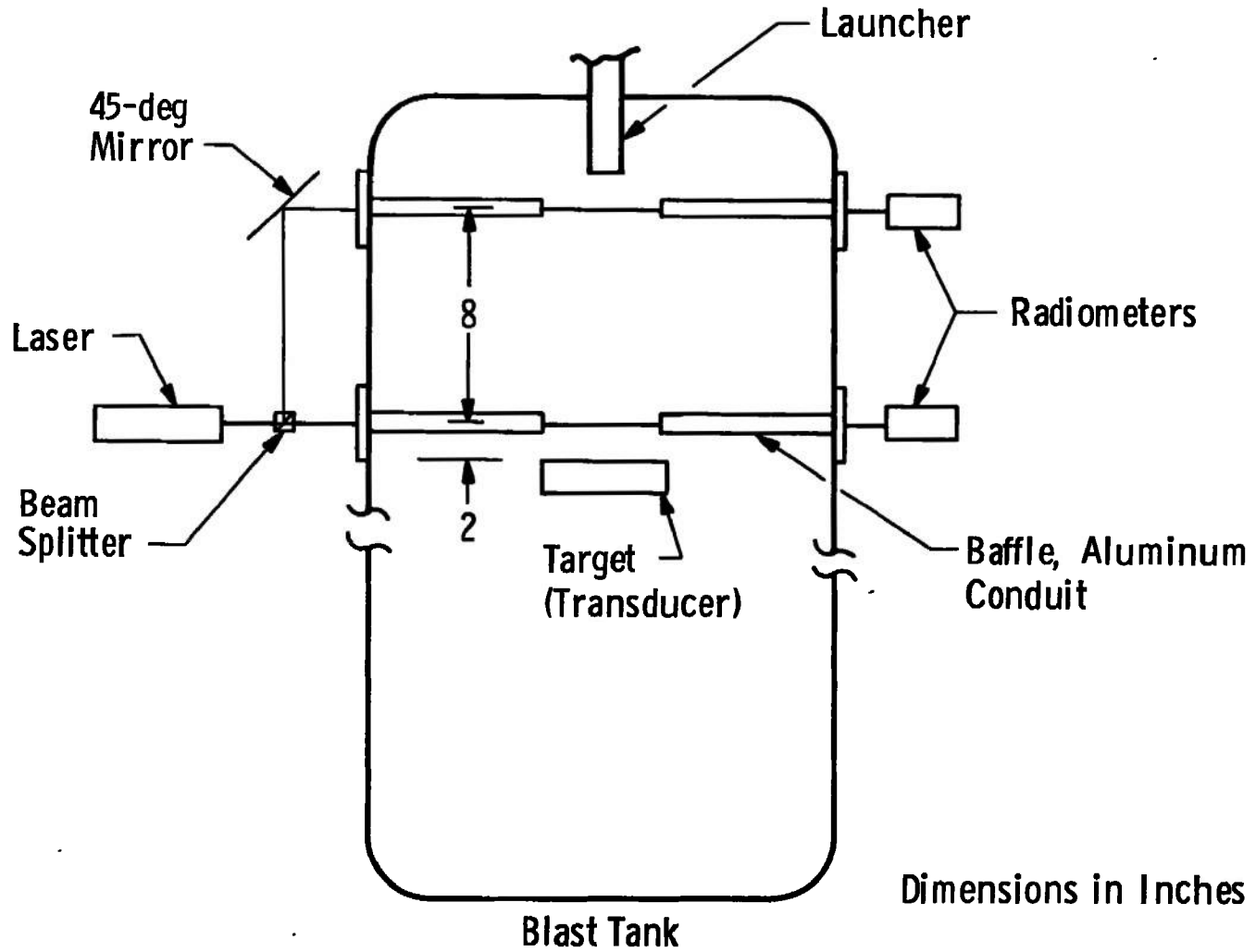
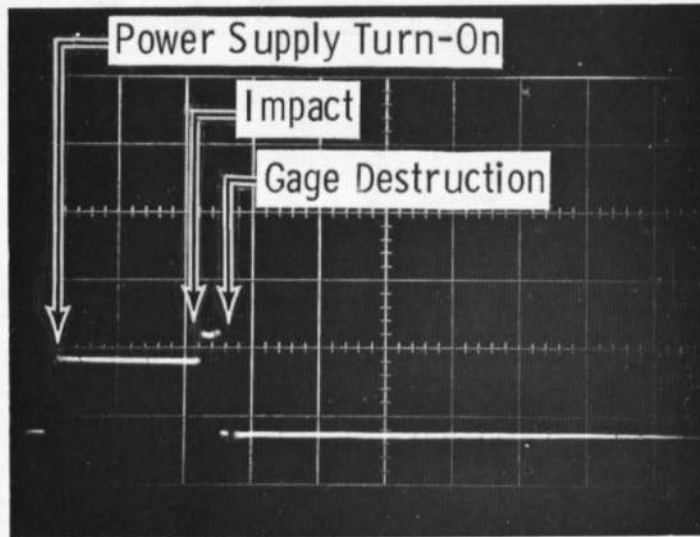

Fig. 5 Range Configuration



Vertical:
0.5 v/cm

Horizontal:
5 μsec/cm

a. OVERALL TRACE

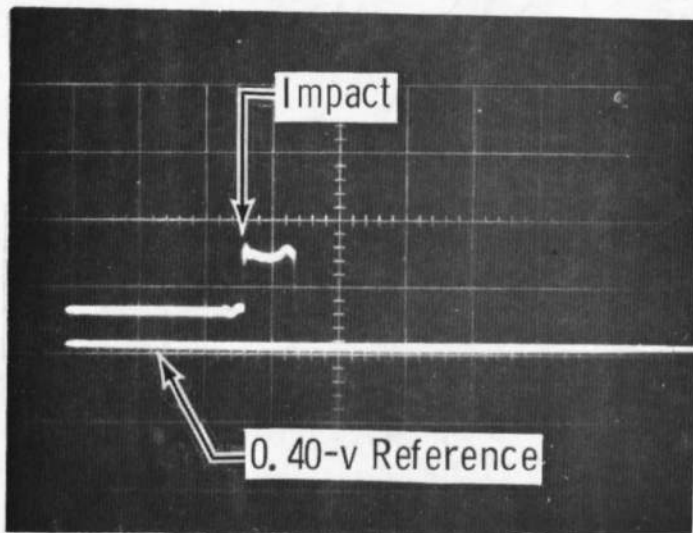

Vertical:
0.2 v/cm

Horizontal:
2 μsec/cm

b. Offset Trace

Fig. 6 Oscilloscope Traces of Transducer Output

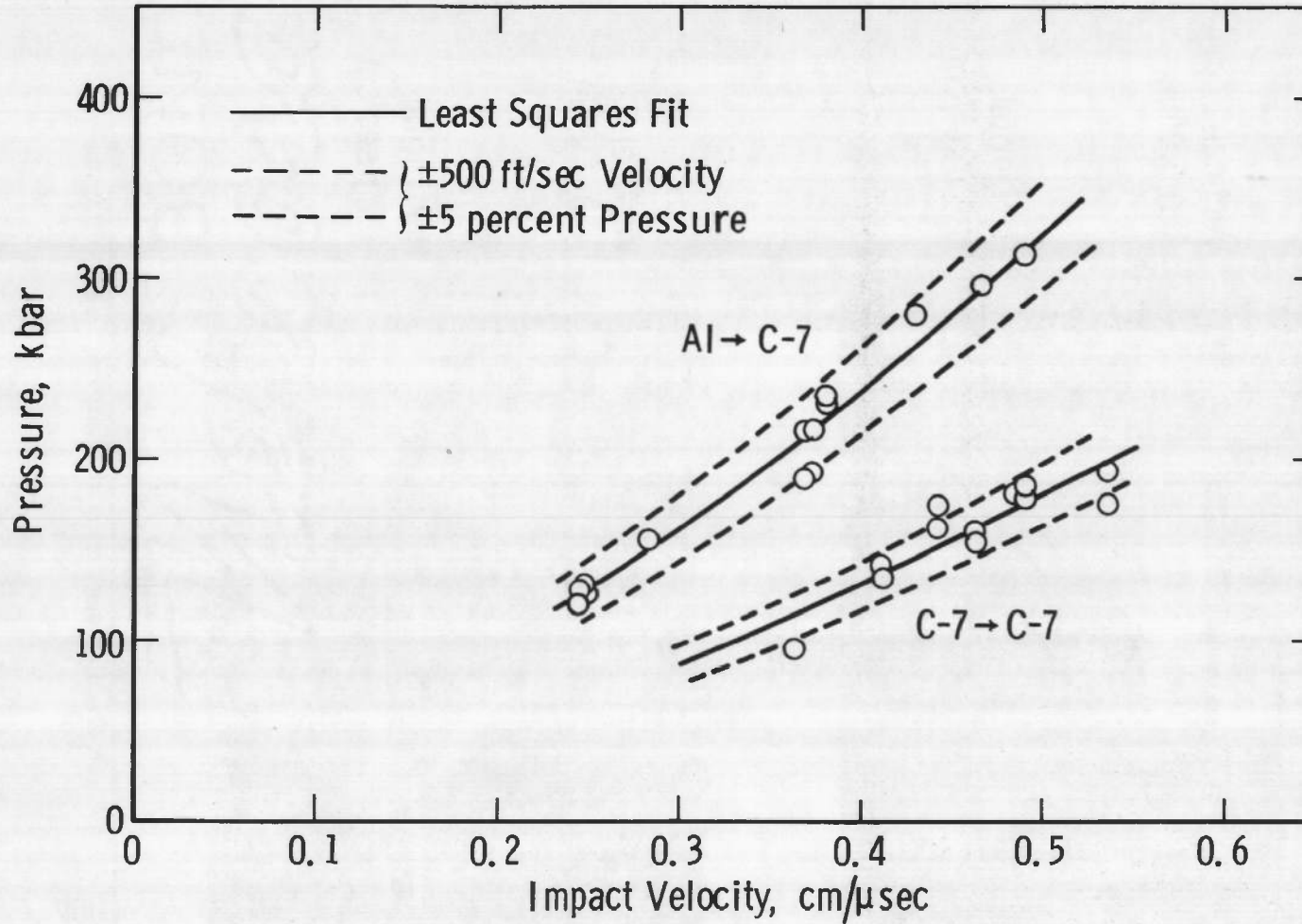

Fig. 7 Experimental Measurements of Aluminum and C-7 Epoxy Projectiles

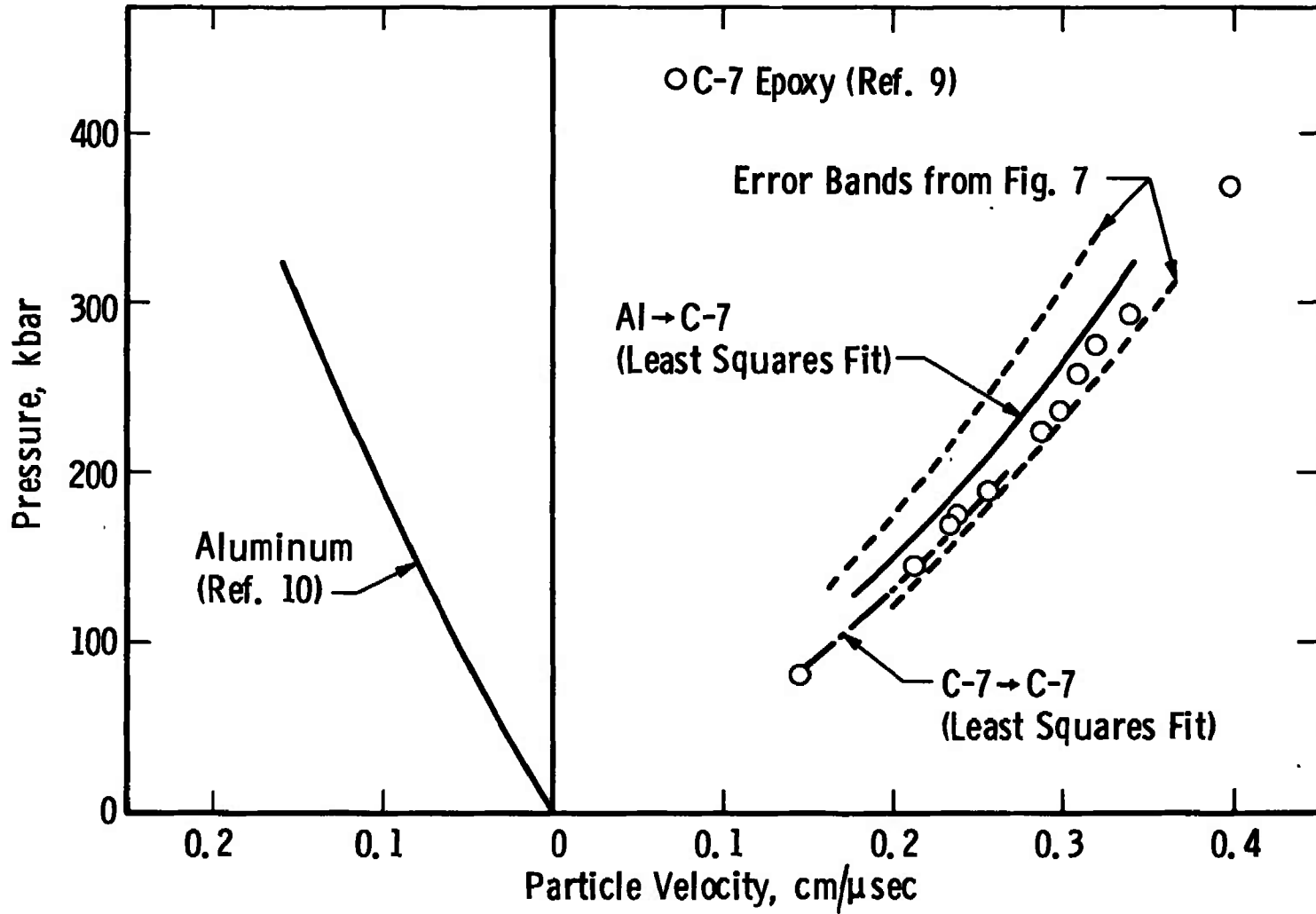

Fig. 8 Pressure versus Particle Velocity for C-7 Epoxy

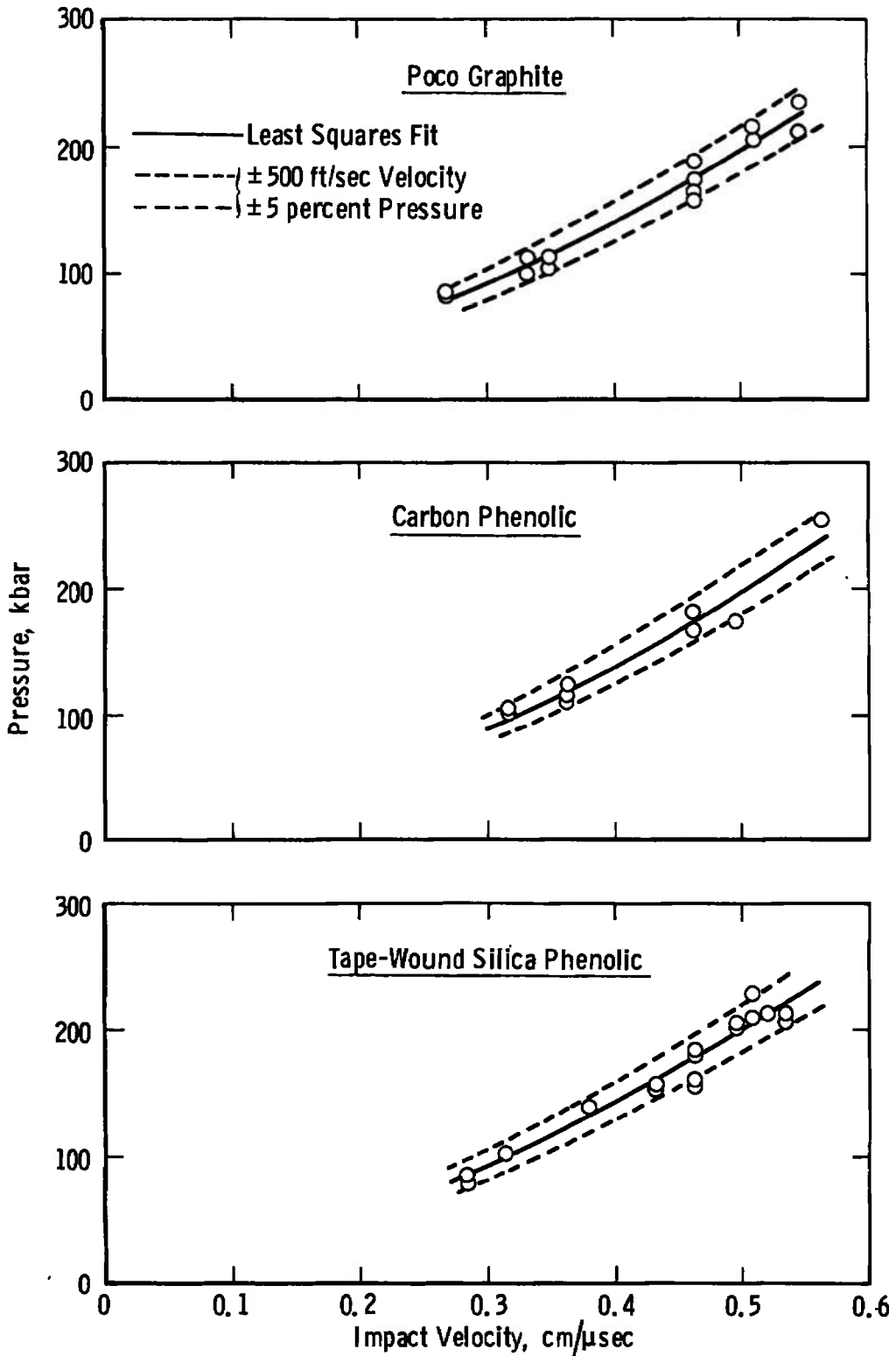

Fig. 9 Experimental Measurements for Materials of Interest

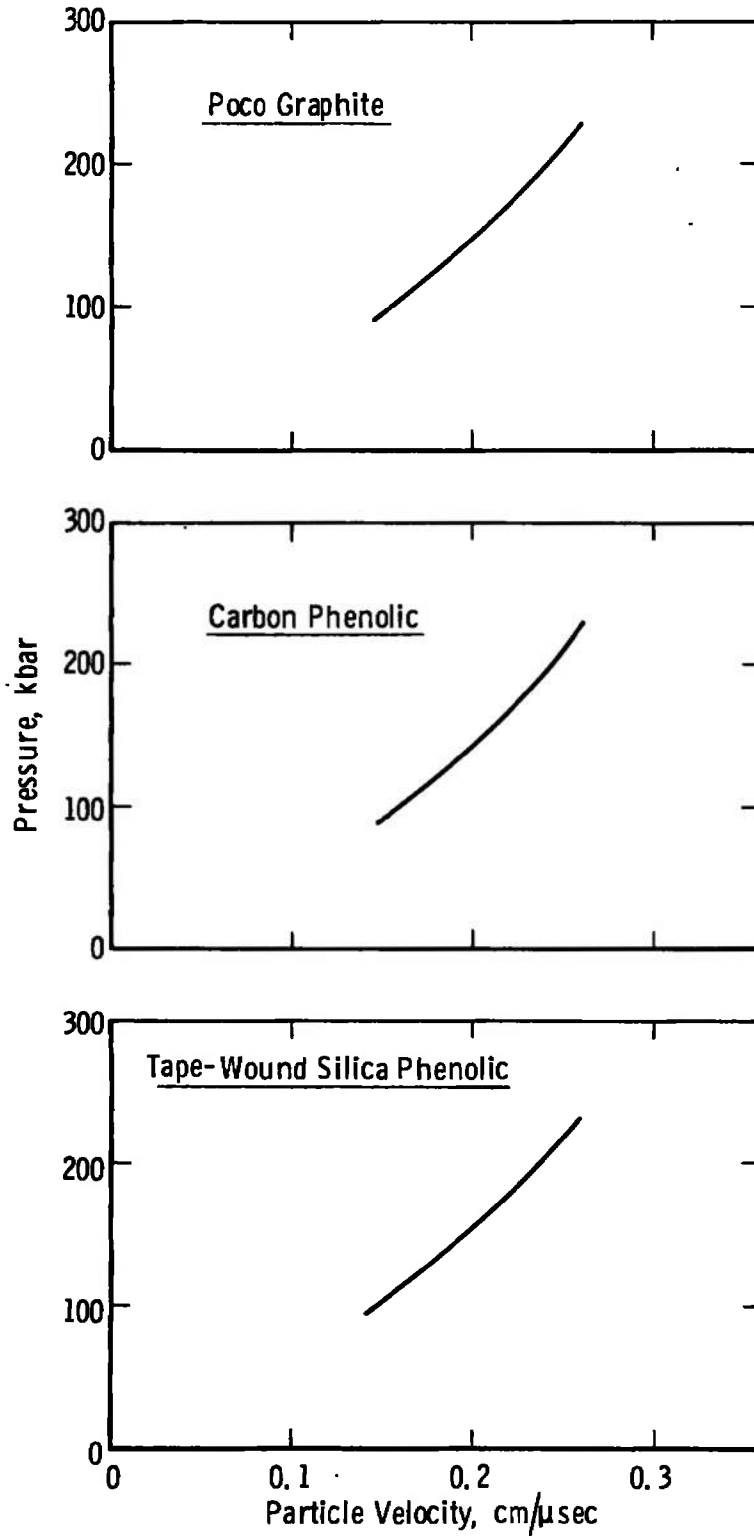

Fig. 10 Particle Velocity Data for Materials of Interest

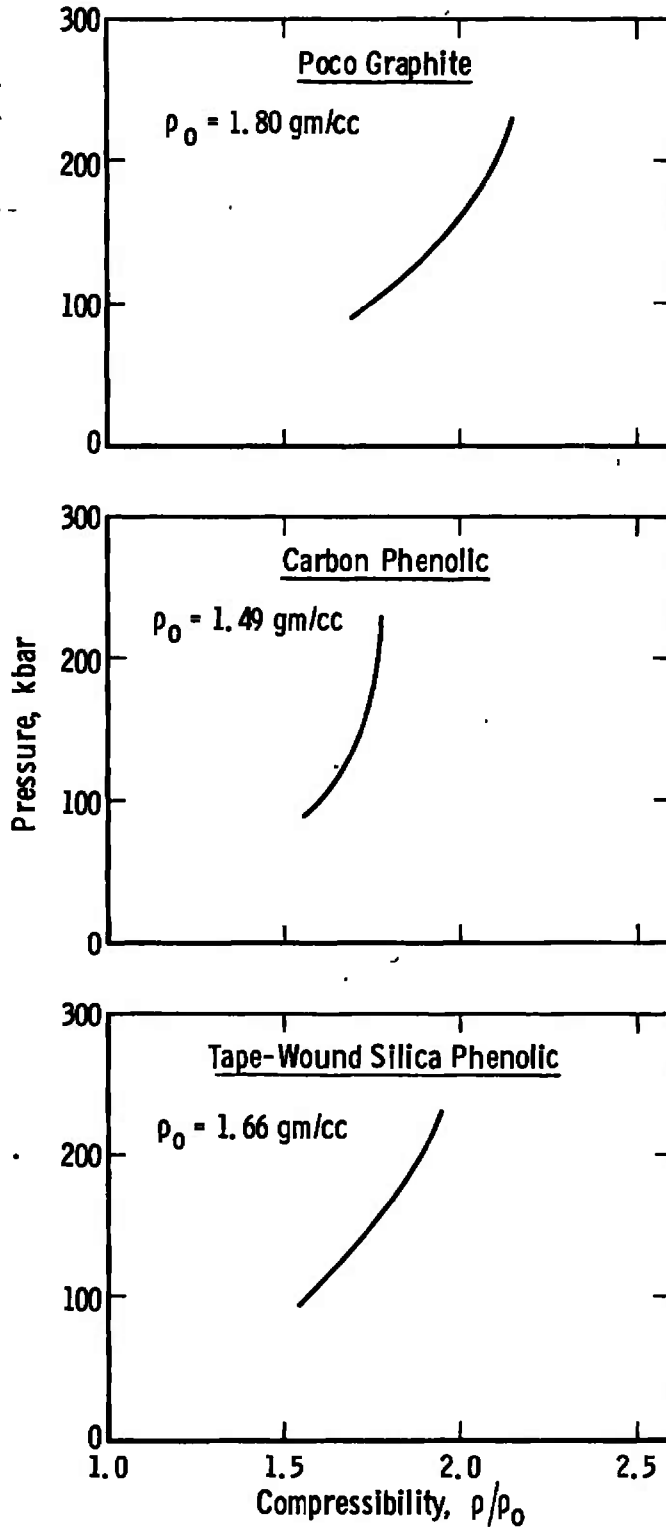

Fig. 11 Compressibility Data for Materials of Interest

TABLE I
EXPERIMENTAL RESULTS

Shot No.	Test Material	Impact Velocity cm/ μ sec	Pressure, kbar	
			Overall Trace	Offset Trace
196	2024 Aluminum ↓	0.466	297	---
197		0.490	313	---
199		0.430	281	---
201		0.248	132	126
202		0.245	119	128
203		0.380	230	235
204		0.369	190	216
205		0.373	194	216
218		0.283	155	---
233	C-7 Epoxy ↓	0.363	96	96
246		0.412	141	134
248		0.442	175	162
249		0.463	162	155
250		0.491	179	186
253		0.485	182	---
254		0.536	193	175
220	Poco Graphite ↓	0.348	103	113
221		0.332	113	100
222		0.267	86	83
223		0.463	---	165
224		0.463	158	---
225		0.509	217	206
227		0.546	237	213
241	0.463	189	175	
209	Carbon Phenolic ↓	0.317	103	106
210		0.363	124	113
211		0.363	117	113
213		0.463	182	168
272		0.497	---	172
273		0.564	255	---
207	TWSP ↓	0.381	141	141
208		0.284	86	79
258		0.314	---	103
259		0.433	158	155
262		0.463	186	182
264		0.497	206	203
265		0.463	162	158
266		0.536	213	206
268		0.509	231	210
270		0.521	213	---

TABLE II
COMPUTED MATERIAL PROPERTIES

Test Material	P, kbar	U _p , cm/μsec	η
Poco Graphite ↓	229	0.261	2.155
	197	0.239	2.091
	167	0.217	2.028
	140	0.193	1.919
	115	0.169	1.809
	91	0.144	1.696
Carbon Phenolic ↓	230	0.260	1.776
	197	0.239	1.761
	166	0.218	1.745
	138	0.195	1.702
	112	0.172	1.648
	89	0.146	1.556
TWSP ↓	230	0.259	1.948
	199	0.237	1.885
	170	0.214	1.812
	143	0.190	1.728
	117	0.167	1.651
	94	0.141	1.538

DOCUMENT CONTROL DATA - R & D

(Security classification of title, body of abstract and indexing annotation must be entered when the overall report is classified)

1. ORIGINATING ACTIVITY (Corporate author) Arnold Engineering Development Center ARO, Inc., Operating Contractor Arnold Air Force Station, Tennessee		2a. REPORT SECURITY CLASSIFICATION UNCLASSIFIED	
		2b. GROUP N/A	
3. REPORT TITLE HIGH PRESSURE HUGONIOT DATA OBTAINED WITH A MANGANIN PIEZORESISTIVE PRESSURE TRANSDUCER			
4. DESCRIPTIVE NOTES (Type of report and inclusive dates) January 4 to October 8, 1968- Final Report			
5. AUTHOR(S) (First name, middle initial, last name) William H. Carden, ARO, Inc., and G. P. Crotwell, Jr., Captain, USAF, Air Force Weapons Laboratory			
6. REPORT DATE April 1969		7a. TOTAL NO. OF PAGES 30	7b. NO. OF REFS 10
6a. CONTRACT OR GRANT NO F40600-69-C-0001		9a. ORIGINATOR'S REPORT NUMBER(S) AEDC-TR-69-83	
b. PROJECT NO 5710			
c. Program Element 65701H		9b. OTHER REPORT NO(S) (Any other numbers that may be assigned this report) N/A	
d. DASA 15.025			
10. DISTRIBUTION STATEMENT This document is subject to special export controls and each transmittal to foreign governments or foreign nationals may be made only with prior approval of Air Force Weapons Laboratory (WLRP), Kirtland AF Base, New Mexico 87117.			
11. SUPPLEMENTARY NOTES Available in DDC.		12. SPONSORING MILITARY ACTIVITY Air Force Weapons Laboratory (WLRP) Kirtland AF Base, New Mexico 87117	
13. ABSTRACT The present investigation was initiated to develop the capability of making Hugoniot solid equation-of-state measurements using a piezoresistive pressure transducer and a two-stage light-gas gun. A Manganin-epoxy transducer was successfully developed to measure pressures up to 350 kilobars when impacted by high velocity cylindrical projectiles of the material being tested. The calibration of the transducer was verified by two independent methods using materials for which the Hugoniot was known. Finally, the technique was used to determine Hugoniot data for tape-wound silica phenolic, carbon phenolic, and poco graphite in a pressure region where previous data did not exist. The technique wherein piezoresistive transducers are used in conjunction with two-stage light-gas guns is unique in its ability to provide high pressure Hugoniot data for this class of materials at modest cost. This document is subject to special export controls and each transmittal to foreign governments or foreign nationals may be made only with prior approval of Air Force Weapons Laboratory (WLRP), Kirtland AF Base, New Mexico 87117.			

14

KEY WORDS

LINK A

LINK B

LINK C

ROLE

WT

ROLE

WT

ROLE

WT

1. transducers

calibration

2 pressure sensors *measurements*

piezoelectricity

3 Manganin® ~~pressure~~ transducer

4 Hugoniot data

light-gas guns

phenolic laminates

impact tests targets

hypervelocity projectiles -- *impacting*

[Handwritten signature]
6-29